

**ANTENNA CONFIGURATION AND ANTENNA GAIN PATTERNS FOR PROPOSED  
MODIFIED FEEDER LINK GATEWAY EARTH STATION ANTENNA**

Section 25.209, titled “Earth station antenna performance standards” is not applicable to the proposed modified feeder link gateway earth station antenna, because this earth station does not operate in conjunction with geostationary satellites:

If the proposed antenna(s) operate in the Fixed Satellite Service (FSS) with geostationary satellite, do(es) the proposed antenna(s) comply with the antenna gain patterns of Section 25.209(a) and (b) as demonstrated by the manufacturer’s qualification measurement.

Nonetheless, GUSA Licensee LLC provides the attached analysis showing that the proposed modified antenna complies with the antenna gain patterns specified in Section 25.209(a)(2) and (b).

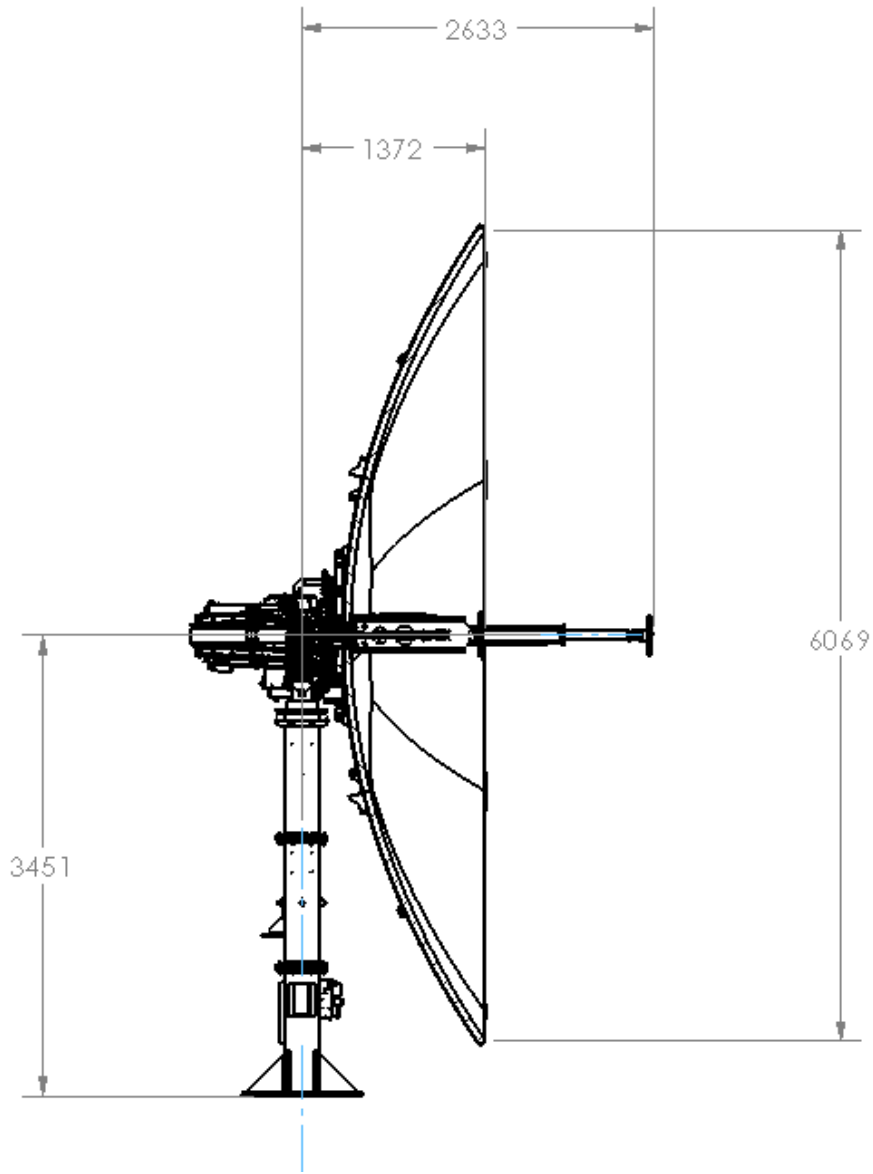

Figure 1. Ground Installation Configuration

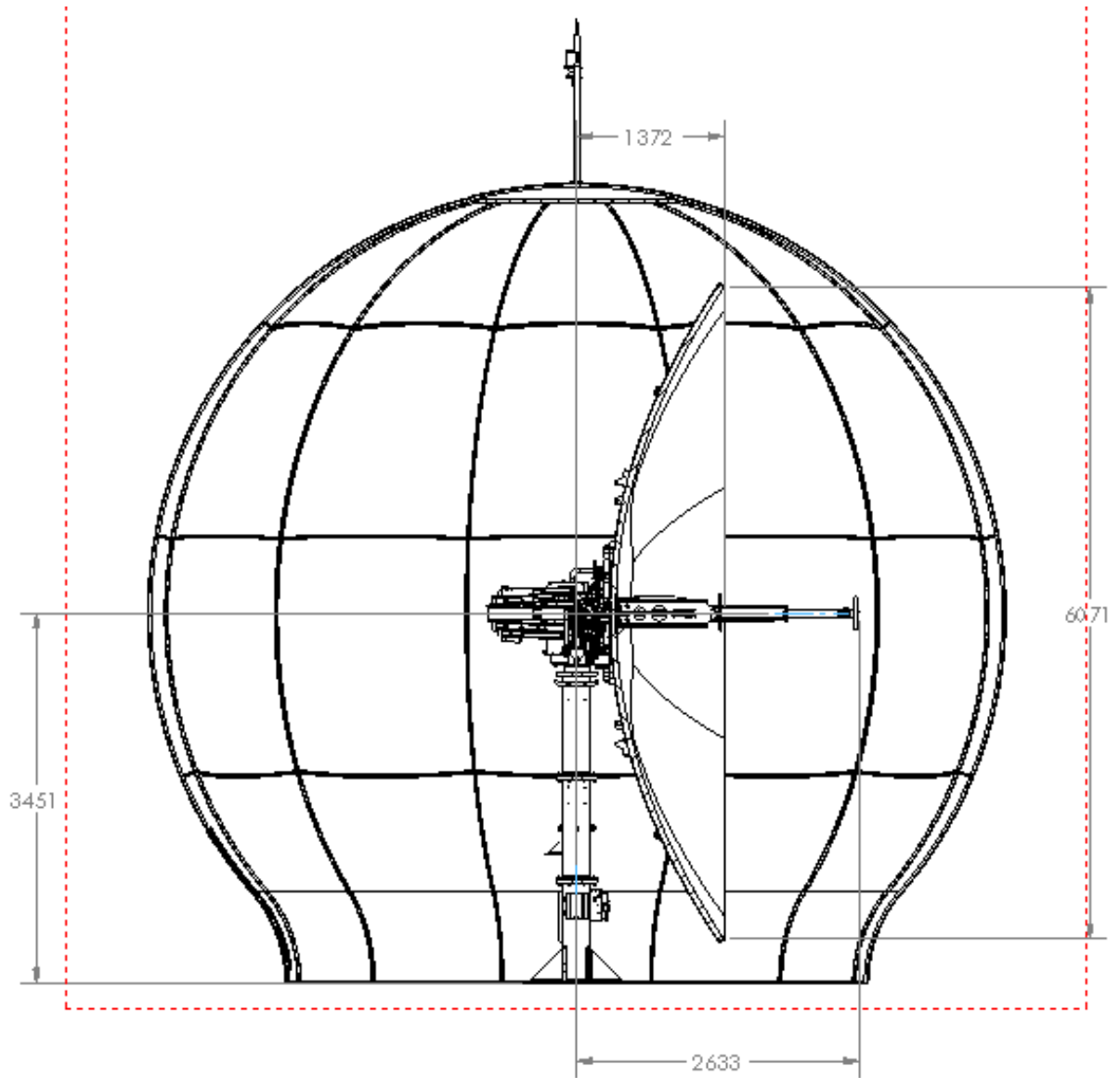

Figure 2. Ground Installation Configuration with Radome

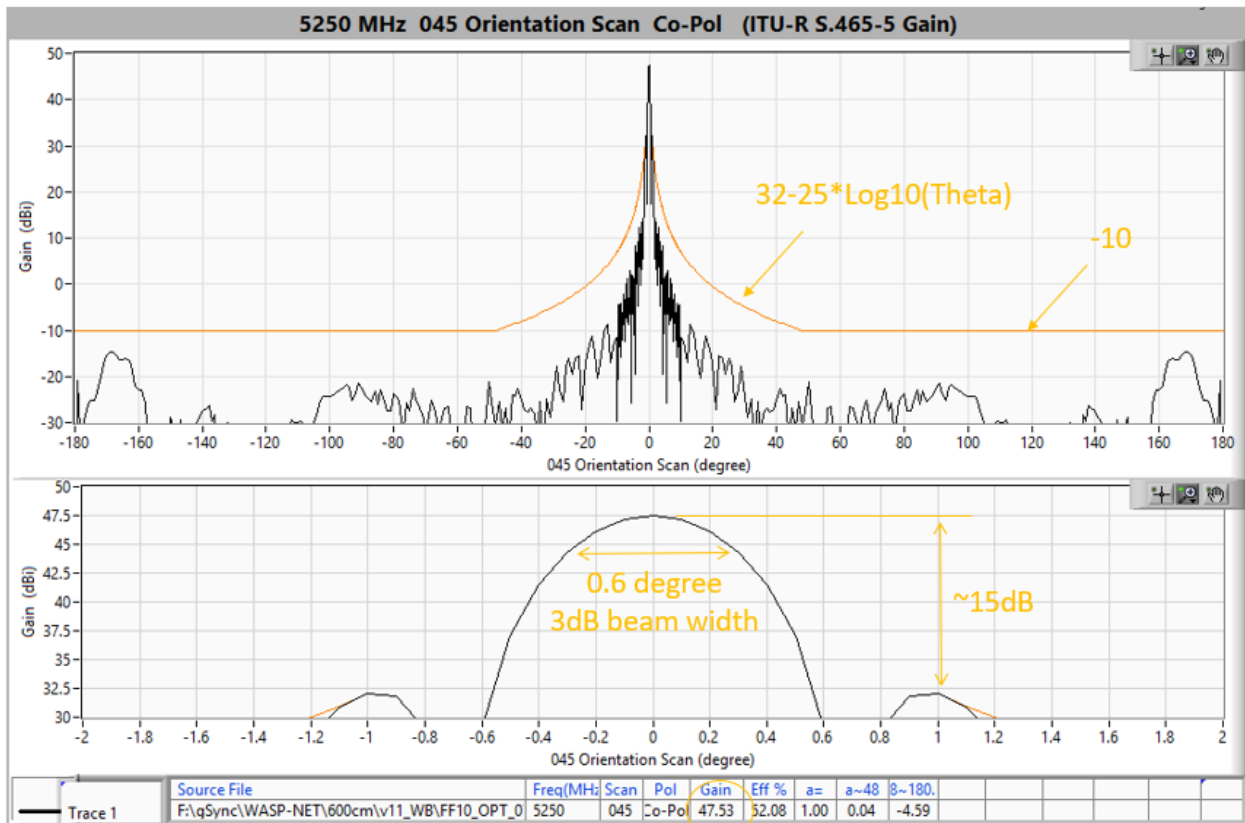

Figure 3. Transmit Antenna Pattern

The specification limit is shown superimposed on the measured pattern data. The first side lobe is typically -15 dB below the main beam.

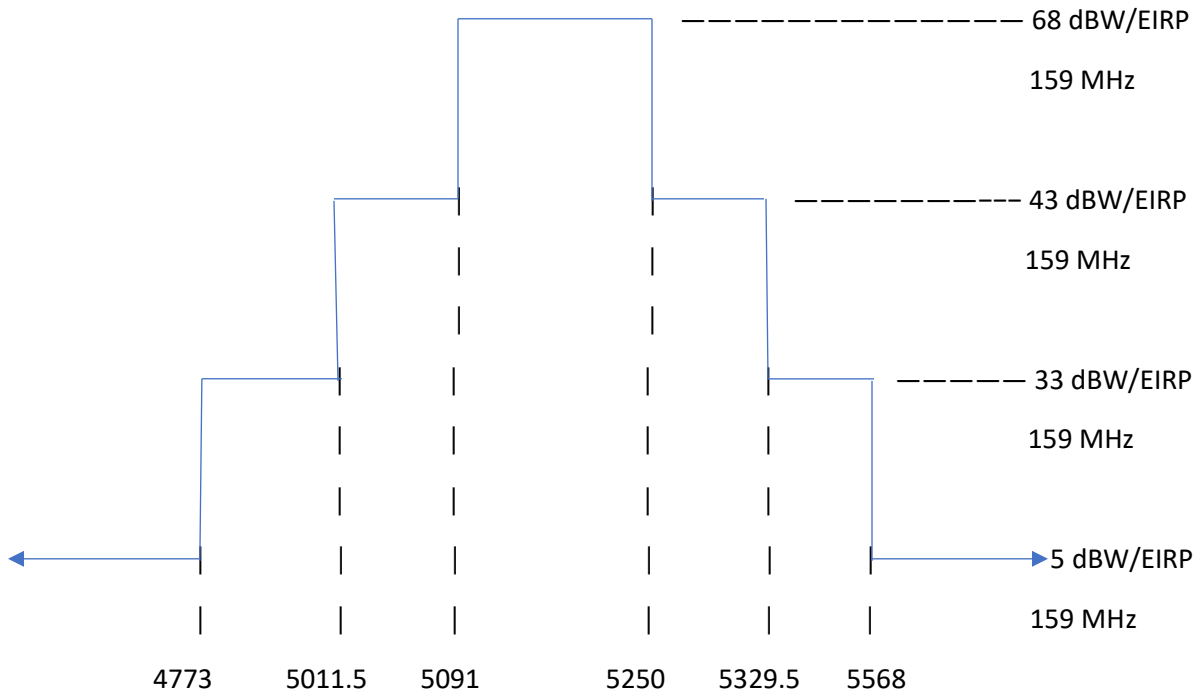

Figure 4. Out of Band Emissions Limits

The proposed modified antenna meets the out of band emission limits as stated above.

## TECHNICAL PARAMETERS FOR PROPOSED MODIFIED FEEDER LINK GATEWAY EARTH STATION ANTENNA

### Carriers

The proposed modified 6-meter feeder link gateway earth station antenna will radiate on carriers modulated with 1.23 MHz CDMA spread spectrum signals. Thirteen such feeder uplink carriers are grouped, which when translated by the satellite represent one 16.5 MHz wide (2483.5 – 2500 MHz) service downlink beam. The service downlink consists of 16 such beams; therefore, the feeder uplink has 16 corresponding groups of 13 feeder link carriers. Eight of these groups are transmitted with LHCP, and the other eight on RHCP. On each polarization, the eight channel groups are separated by 2.88 MHz guard bands to mitigate adjacent channel interference. These eight channel groups, representing a total of 104 CDMA carriers, occupy the band from 5096 – 5249.12 MHz, with the lowest carrier centered at 5097.85 MHz. The aggregate power from all the channels on a given polarization will not exceed 68.4 dBW EIRP. In addition, the gateway will transmit satellite telecommand carriers on the LHCP in the band 5091 – 5092 MHz. A telecommand carrier is modulated in about 240 kHz and radiates at a nominal 53 dBW and at an emergency level up to 68 dBW. The telecommand carrier and feeder links may be used at the same time, but the feeder links will never be used under emergency telecommand conditions, i.e. with a telecommand carrier EIRP level up to 68 dBW.

### Maximum Spurious EIRP in the 5000 – 5091 MHz Band

The proposed modified gateway earth station antenna will meet the unwanted (out-of-band and spurious) emissions limitation requirements for satellite communications earth stations, specified in Section 25.202(f) of the Federal Communications Commission's rules. These limits are:

-3 dBW/4 kHz from 5011.5 – 5091 MHz

-13 dBW/4 kHz from 5000 – 5011.5 MHz

The fundamental power spectral density limit of -3 dBW/4 kHz (at 5091 MHz, on antenna boresight) applies under all operational conditions including emergency telecommand operation. For calculating the out-of-band range trigger, the full EIRP of the telecommand carrier was considered, which is 68.4 dBW. The value of -3 dBW/4 kHz is an EIRP density at 5091 MHz referenced on antenna boresight, assuming maximum transmitter power. This input parameter for our analysis is consistent with Section 25.202 (f), has been verified by the manufacturer, and will be met by the proposed gateway antenna. The value of -55.3 dBW/4 kHz is an EIRP density, also at 5091 MHz, accounting for the worst-case off-pointing between the gateway antenna and the highest elevation angle to the Microwave Landing System (MLS) coverage region as viewed from this antenna. The off-pointing angle is 10.3 degrees, considering both the obscure and the geometry to the MLS coverage region, which leads to a sidelobe gain of -4.3

dBi. This is at least 52.3 dB below the 47.53 dBi peak gain of the antenna. The 52.3 dB sidelobe isolation, plus the -3 dBW/4 kHz EIRP density on boresight, lead to the referenced value: a directive EIRP density of -55.3 dBW/4 kHz. Note that this assumes an antenna characteristic of

$$G(\theta) = 32 - 25 \log(\theta),$$

which has also been verified by the manufacturer and will be met by the proposed gateway antenna. Measured data for this antenna is included below as Figure 1.

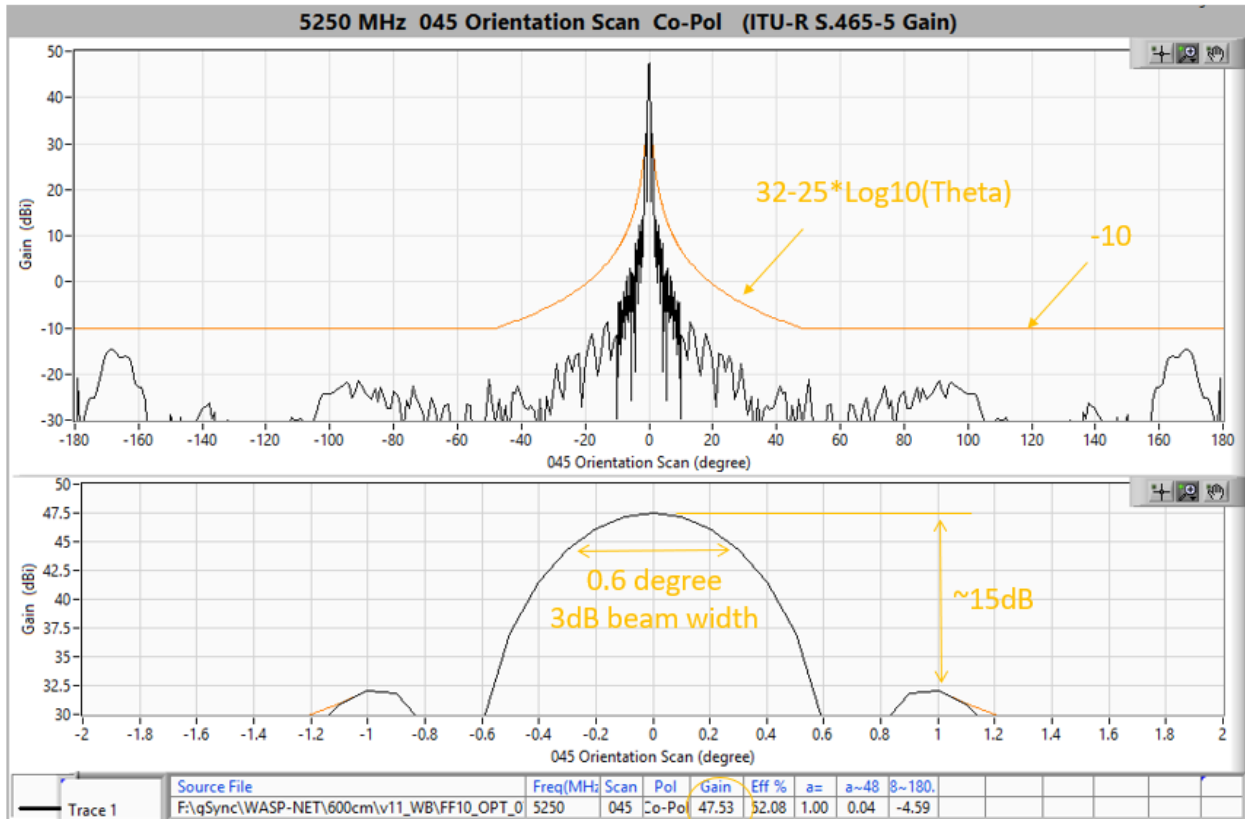

Figure 1 Measured antenna pattern for the proposed antenna

### Antenna Pattern

47.53 dBi nominal transmit gain

3 dB beamwidth of 0.6 degrees

**GUSA Licensee LLC**  
**Response to FCC Form 312, Question E15 – ATTACHMENT 2**  
**Page 3 of 3**

First sidelobe at least 15 dB down

Sidelobe envelope of

$32 - 25 \log(\theta)$  dBi,  $1 \text{ degree} < \theta < 48 \text{ degrees}$

-10 dBi,  $48 \text{ degrees} < \theta < 180 \text{ degrees}$

**Scan Parameters**

Due to the inclined orbits used by the satellite constellation, the proposed modified feeder link gateway earth station antenna will view the satellites and transmit above an elevation angle of 5 degrees in all azimuth directions.