

Technical Brief for L3 VMES System

January 28, 2013

ITC Document No:
100_20120930m01v07.4_WinT_Technical_Brief.docx



Prepared by:
Intellicom Technologies, Inc.

Approved by:



Paul Moller
Vice-President, Intellicom Technologies Inc.

This document contains confidential Technical Data considered to be a commercially valuable resource. This data is provided strictly in support of obtaining an FCC license. The document is provided to satellite operators and the FCC in support of the licensing process. The document shall not be distributed to any party that is not supporting evaluation of the license application.

iNTELLICOM Technologies, Inc.

PO Box 27056, San Diego, CA 92198
Tel: (858) 486-1115, www.ITCcom.net

Revision History

| Revision History: | Date | Document Revision Description |
|-------------------|------------|---|
| V01-V02 | 2012-09-30 | Initial drafts |
| V03-V04 | 2012-10-03 | Update Sections 1 through 10 |
| V05 | 2012-11-03 | Updates by pm. |
| V06 | 2012-11-05 | Updates by wb. Includes Section 3, Section 9, TOC, List of Figures, and List of Tables. |
| V07.1 | 2012-12-07 | Release to L3 |
| V07.2 | 2013-01-14 | Release to L3, Update antenna pointing analysis |
| V07.3 | 2013-01-24 | Minor changes. |
| V07.4 | 2013-01-28 | Minor changes. |



TABLE OF CONTENTS

| | |
|---|-----------|
| TABLE OF CONTENTS | 3 |
| LIST OF FIGURES | 4 |
| LIST OF TABLES..... | 4 |
| 1 INTRODUCTION | 5 |
| 1.1 Regulatory Compliance | 6 |
| 1.2 Referenced Documents | 7 |
| 2 SYSTEM DESCRIPTION..... | 8 |
| 2.1 Network Configuration | 10 |
| 2.2 Master/Hub Station | 11 |
| 2.3 Mobile Earth Station | 12 |
| 2.3.1 EIRP Linearity | 13 |
| 2.3.2 L3/Linkabit RMPM-1000 Modem and Controller Assembly | 13 |
| 2.3.3 L3/Datron FSS-4180-LC Antenna Assembly | 14 |
| 2.3.4 Management | 15 |
| 2.3.5 Contention Channel..... | 15 |
| 2.3.6 Data Logging | 16 |
| 2.3.7 Disable Provisions | 16 |
| 3 ANTENNA | 17 |
| 3.1 Gain Patterns..... | 17 |
| 3.2 EIRP Power Spectral Density (EPSD) Patterns..... | 18 |
| 3.2.1 Use of Direct Sequence Spread Spectrum (DSSS)..... | 18 |
| 3.3 Pointing Error..... | 22 |
| 4 TRANSMIT CARRIERS | 23 |
| 4.1 Mobile Earth Station Carriers..... | 23 |
| 4.1.1 Assigned Carriers (AROW, DCOM)..... | 23 |
| 4.1.2 Contention Carrier (CROW) | 23 |
| 4.2 Master/Hub Earth Station Carriers..... | 24 |
| 4.3 Transmit Carrier..... | 24 |
| 4.3.1 VMES Transmit | 24 |
| 4.3.2 Hub Transmit..... | 24 |
| 5 APPENDIX – SAMPLE LINK BUDGET | 25 |
| 6 APPENDIX – DATA LOGGING..... | 30 |
| 6.1 Requirements | 30 |
| 6.2 Compliance..... | 30 |
| 7 APPENDIX - DISABLE PROVISIONS | 32 |
| 7.1 RF Mute on Pointing Error | 32 |
| 7.2 Self-Monitor Conditions for Modem Transmission | 32 |
| 7.3 Mute on Loss of Lock | 33 |
| 7.4 Temporarily Disable Remote NM..... | 33 |
| 7.5 Permanent Disable Remote NM | 33 |
| 8 APPENDIX - ANTENNA POINTING ANALYSIS | 34 |
| 9 FSS-4180-LC Brochure..... | 37 |
| 10 RMPM-1000 Modem Brochure | 39 |

LIST OF FIGURES

| | |
|---|----|
| Figure 1. Photo of FSS-4180-LC with Radome Removed. | 8 |
| Figure 2. Photo of FSS-4180-LC with Radome..... | 9 |
| Figure 3. Photo of RMPM-1000 Modem. | 9 |
| Figure 4. Simplified Block Diagram of a Typical Network..... | 11 |
| Figure 5. Hub Earth Station with 120 W HPA and a 3.7 m Antenna. | 11 |
| Figure 6. Block and Level Diagram of FSS-4180-LC Transmit Assembly..... | 12 |
| Figure 7. Block and Level Diagram of FSS-4180-LC Receive Assembly..... | 12 |
| Figure 8. EIRP Linearity Chart, Typical..... | 13 |
| Figure 9. 18" Antenna Reflector Photo..... | 15 |
| Figure 10. Antenna Gain Plotted against FCC Standards 25.209 - $+10^{\circ}$ | 17 |
| Figure 11. H Pol, AZ Axis..... | 20 |
| Figure 12. H Pol, EL Axis..... | 20 |
| Figure 13. V Pol, AZ Axis..... | 21 |
| Figure 14. V Pol, EL Axis..... | 21 |
| Figure 15. Telstar 14 EIRP CONUS, Coastal and Caribbean EIRP Footprint.... | 25 |
| Figure 16. Tracking Error from Boresight..... | 35 |
| Figure 17. Results of Churchville B course on a Motion Simulator. | 35 |
| Figure 18. Cumulative Distribution Function. | 36 |

LIST OF TABLES

| | |
|---|----|
| Table 1. Antenna Gain Plots Assumption. | 17 |
| Table 2. Meeting ESPD per 25.226 using DSSS. | 19 |
| Table 3. Emission designations for VMES to Hub Communications..... | 23 |
| Table 4. Emission Designations for Hub to VMES Communications. | 24 |

1 INTRODUCTION

L3 is seeking a permanent FCC VSAT/blanket license for the operation of one of its Vehicle-Mounted-Earth-Station (VMES) Communications-on-the-Move (COTM) SATCOM system having a Model Number of FSS-4180-LC. Verification of the system has been performed since June/2005 under an FCC experimental license. A similar system FSS-4180-LP has been licensed by the FCC (call sign E100099, issued March 2, 2011).

This document provides technical information regarding the intended operations of the L3 system. Operations are such that they comply with FCC rulings for off-axis Power Spectral Density.

The system utilizes advanced antenna pointing technology, spread spectrum modulation, and centralized and distributed controls to ensure that interferences to others meet the requirements of the FCC and the ITU.

L3 is seeking a permanent VSAT/blanket FCC license for:

- **L3/Linkabit R/MPM-1000 Modem and Controller Assembly**
- **L3/Datron FSS-4180-LC Antenna Assembly**
- **Ku Band**
 - **14.0-14.5 GHz,**
 - **11.7-12.2 GHz**
- **Extended Ku Band**
 - **13.75-14.5 GHz,**
 - **10.95-12.75 GHz**
- **All CONUS operation +Hawaii**
- **Alsat Operation**
- **Mobile operation**

Intellicom Technologies, Inc. is representing L3 in this matter; please feel free to contact the following for additional information, comments, or clarifications:

Paul Moller
Intellicom Technologies, Inc.
480-993-2220
PMoller@ITCcom.net
www.ITCcom.net

1.1 Regulatory Compliance

The L3 system is filed as compliant with **47CFR25.226** paragraph **(a)(1)** as follows:

- **(a)(1)(i)** the Vehicle Mounted Earth Station (VMES) uses transmitters with off-axis EIRP spectral-densities lower than or equal to the levels in paragraph (a)(1)(i)
- **(a)(1)(ii)(A)** Each VMES transmitter shall maintain a pointing error not to exceed **0.2°** between the orbital location of the target satellite and the axis of the main lobe of the VMES antenna
- **(a)(1)(iii)(A)** all emissions from the VMES will automatically cease within 100 milliseconds if the angle between the orbital location of the target satellite and the axis of the main lobe of the VMES antenna exceeds **0.5°**, and transmission shall not resume until such angle is less than or equal to **0.2°**

In addition, this filing is compliant and provides the information set forth in paragraphs

- (a)(4) through (a)(9) and
- (b), (c), (d), and (e)

1.2 Referenced Documents

[1] “18” Circular Antennal Plots”, 200_20121019m01vxx_AntennaPlots, January 2013.

[2] “18” Circular Antenna Tabular Data”, 300_20121019m02vxx_TabularData, January 2013.

[3] “Contention Channel Analysis”,
400_20121103m01vxx_WinT_ContentionChannel, January 2013.

[4] “Supplemental information in support of Form 312”,
500_20121103m02vxx_WinT_Form312, January 2013.

2 SYSTEM DESCRIPTION

The FSS-4180-LC VMES system is an upgrade to the already proven and FCC accepted FSS-4180-LP VMSS terminal, with the following exceptions:

- The LC antenna is an 18" circular (the FSS-4180-LP uses a lower profile 18" x 13" main reflector),
- The Solid State Power Amplifier (SSPA) is reduced to 12 Watts (41 dBm maximum power @ P_{1dB}) and is integrated with an L band to Ku band Block Up Converter (BUC),
- The LC utilizes an embedded Inertial Measurement Unit (IMU), and
- Repackaged

All of these steps help to reduce the manufacturing costs with the cost savings being passed on to the customer. A photo of the FSS-4180-LC terminal is shown in [Figure 1](#) with the radome removed, and [Figure 2](#) with radome on.

Figure 1. Photo of FSS-4180-LC with Radome Removed.



Figure 2. Photo of FSS-4180-LC with Radome.



The terminal utilizes the same rugged networking modem (nomenclature RMPM-1000), manufactured by L3-Linkabit. This modem can operate in two distinct modes, networking (MF-TDMA) or SCPC, with the latter being fully compliant with MIL-STD-188-165A (although the latter does not incorporate DSSS)¹. A front panel photo is shown in [Figure 3](#).

Figure 3. Photo of RMPM-1000 Modem.



¹ DSSS = Direct Sequence Spread Spectrum.



2.1 Network Configuration

The network provides point-to-point 32 kbps to 4.096 Mbps duplex satellite data links while using a small (<1m) antenna operated in a mobile environment. A simplified block diagram ([Figure 4](#)) shows a typical network, with a main hub, a backup hub and then a series of remote terminals (FSS-4180-LC).

The network consists of:

- **Network Members:** These stations are under continuous (remote) control and monitoring from the Network Controller. Network members cannot transmit unless they receive the signaling channel from the Network Controller.
- **Geostationary Satellite:** Space segment resources are leased from the available commercial satellite operators.
- **Network Controller:** The network controller provides resource management of the leased space segment and continuously monitors and controls the Network Members. The network operator will either provide on-site 24x7 support or on-call rapid responses for the Network Controller. The satellite space segment operations center shall be provided with the network operator's phone number for rapid fault resolution.
- **Back-Up Network Controller:** If the Network Controller fails, then all transmissions will cease unless the failed Network Controller recovers or a back-up pre-authorized Network Member detects the failure and becomes configured as the new Network Controller.
- **Power, Frequency, Timing Control.** Modems and frequency converters are phase locked to an accurate and stable 10 MHz reference. If any converters loose lock, then their transmitter is muted. In addition to managing all Network Members, the Network Controller monitors and adjusts their power, frequency and timing accuracy.

Figure 4. Simplified Block Diagram of a Typical Network.

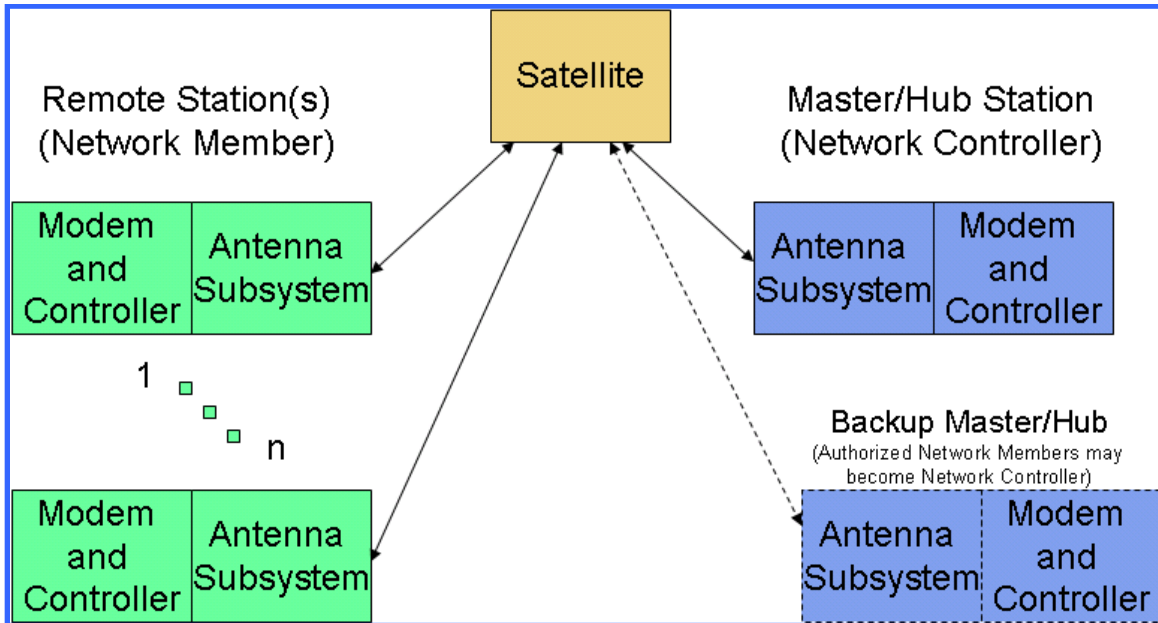

2.2 Master/Hub Station

The master/hub earth station consists of an L3/Linkabit RMPM-1000 Modem, an RF transmitter, and a 3.7 m antenna (other antenna sizes from 2.4 m up can be selected, although this document refers to a 3.7 m). The hub earth station is capable of producing 71 dBW EIRP. The hub earth station is licensed under FCC call sign E000002² ([Figure 5](#)).

Figure 5. Hub Earth Station with 120 W HPA and a 3.7 m Antenna.

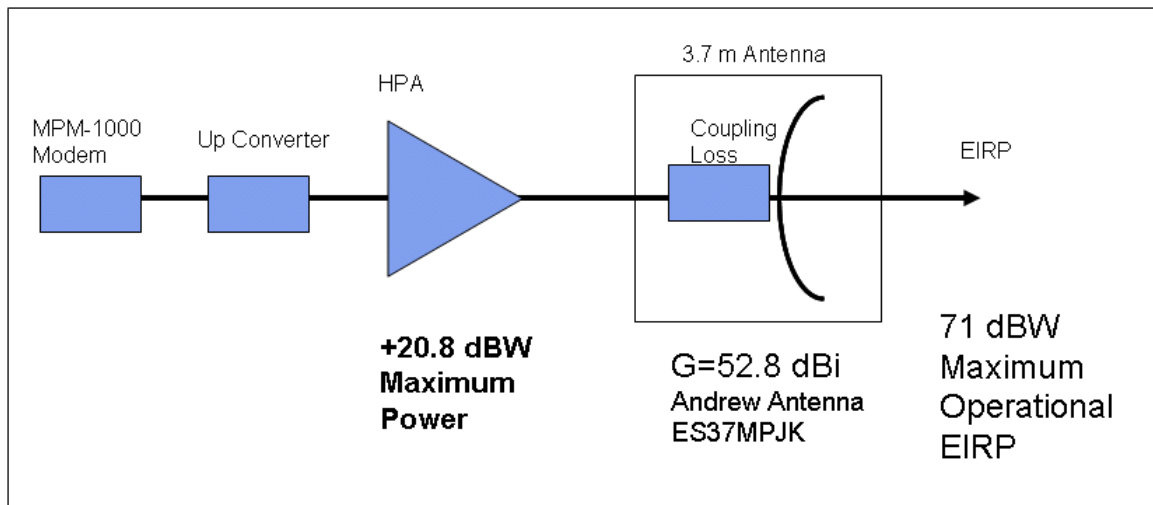

² Radio Station Authorization, Call Sign E000002, File SES-MOD-20090908-01131, 11/24/2009.

2.3 Mobile Earth Station

The mobile earth station consists of:

- an L3/Linkabit RMPM-1000 Modem, and
- an L3/Datron FSS-4180-LC antenna assembly.

The FSS-4180-LC earth station is capable of producing up to **44.5 dBW EIRP**. The RF transmit portion consists of an integral BUC and SSPA and an 18” Cassegrain antenna. **Figure 6** is a simplified block and level diagram of the FSS-4180-LC transmit section, along with the companion RMPM-1000 modem. (Other manufacturers’ modems that include DSSS may be substituted.)

Figure 6. Block and Level Diagram of FSS-4180-LC Transmit Assembly

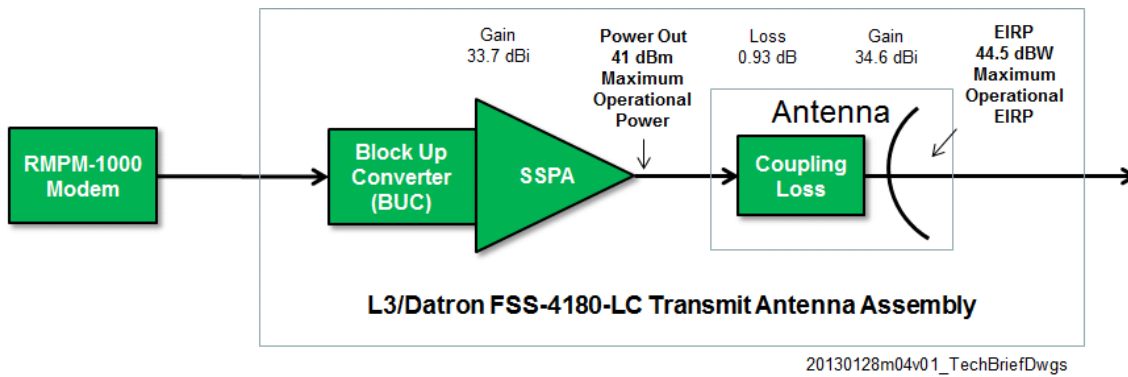

The FSS-4180-LC is a full transmit and receive terminal, and although the receive portion is not required for meeting the 47CFR§25.226 specification, it is provided herein for reference only. **Figure 7** shows a simplified block and level diagram of the FSS-4180-LC receive section, which includes the RMPM-1000 modem.

Figure 7. Block and Level Diagram of FSS-4180-LC Receive Assembly.

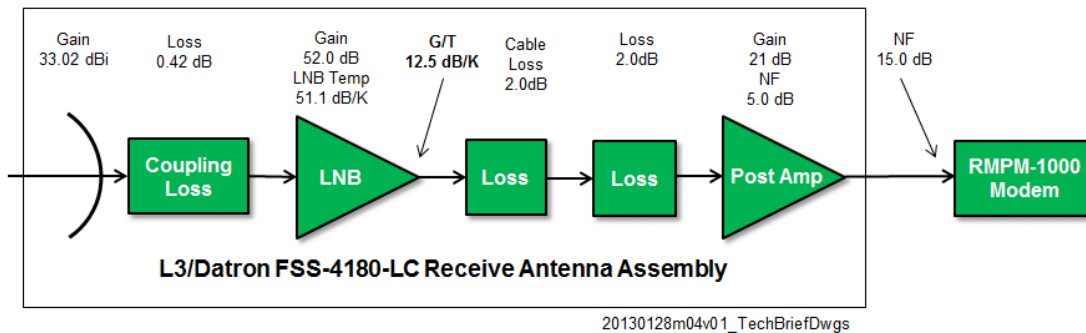

2.3.1 EIRP Linearity

Input versus output linearity tests were conducted on one of the FSS-4180-LC terminals, with the results being charted in **Figure 8**. This chart depicts the EIRP linearity, with this terminal producing a P_{1dB} EIRP of 45.0 dBW and a P_{sat} of 46.0 dBW. This is typical for this terminal, with linear power being 1 dB below P_{1dB} , or 44.0 dBW P_{LIN} .

Figure 8. EIRP Linearity Chart, Typical.

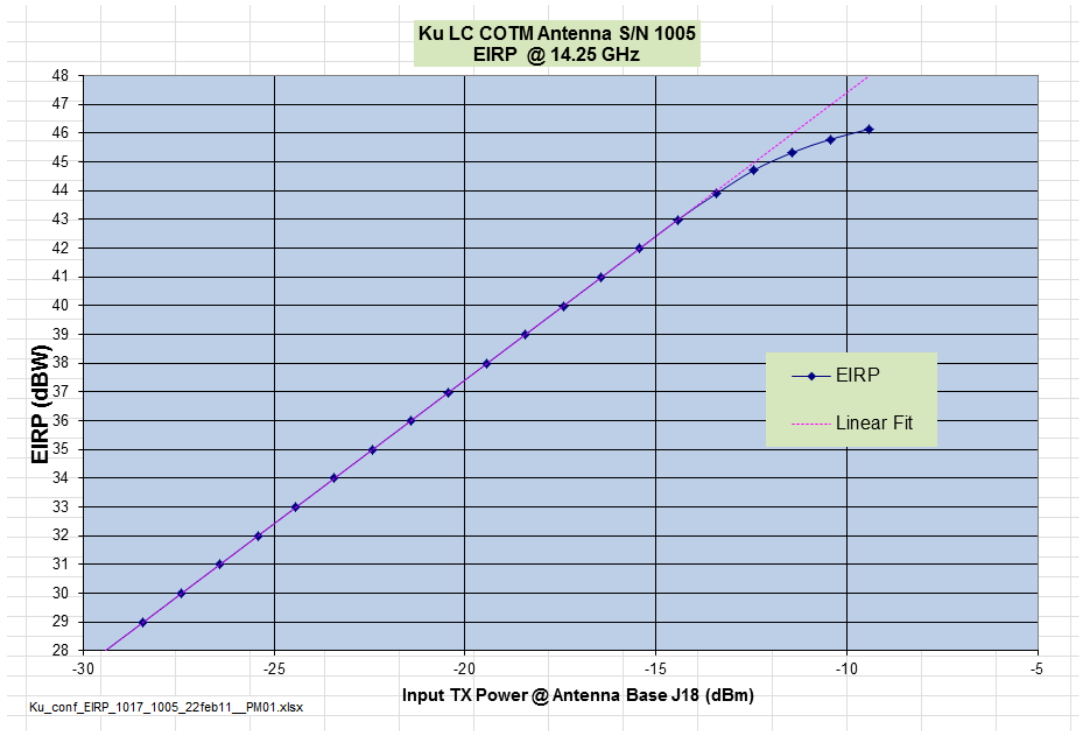

2.3.2 L3/Linkabit RMPM-1000 Modem and Controller Assembly

The Modem and Controller Assembly consists of:

- Modulator
- Demodulator
- Turbo codec
- Stable clock, reference, and distribution
- Frequency conversion to/from L Band
- Controller, configurable as a:
 - Network Member, or
 - Network Controller (including resource manager)
- Ethernet Interface/Switch
- QOS manager
- Human Machine Interface

Each ground station includes a modem and controller assembly. The modem provides data conversion, error correction encoding/decoding, and modulation/demodulation. The controller provides fault, configuration, account/resource, performance, and security management (FCAPS - FM, CM, AM, PM, SM).

2.3.2.1 Modulation

Stations modulate using BPSK or QPSK. If the station has an antenna less than 1m in diameter, then DSSS (direct sequence spread spectrum) BPSK is transmitted if required to keep the EIRP density within required spectral density limits. The range of data rates, modulation, and coding include:

| | |
|-----------------|---------------------------------|
| Modulation: | BPSK (R ½), OQPSK (R ½, 2/3, ¾) |
| Data Rates: | 32 kbps to 4096 kbps |
| Coding: | Turbo Coding |
| BPSK Spreading: | 1x to 16x |

Typically DSSS BPSK, R ½ FEC will be utilized to ensure that the EIRP density meets spectral density limits.

2.3.2.2 Access Scheme

The access scheme used is Multi-Frequency Time Division Multiple Access (MF-TDMA). The Network Controller provides real-time resource management through time slot, frequency center, and carrier bandwidth assignments to the Network Members via a common signaling channel. In the leased bandwidth, the Network Controller may assign multiple frequency slots for each burst time. All stations can hop frequencies from burst to burst, but there will only be one transmit carrier per frequency slot per burst.

While spread spectrum is used as a method to reduce transmitted power spectral density, it is NOT USED as a multiple access scheme. Multiple access is achieved using MF-TDMA and is under control of the Network Controller. N is equal to one³ for this time division multiple access (TDMA) technique.

2.3.3 L3/Datron FSS-4180-LC Antenna Assembly

The antenna subsystem consists of:

- Antenna Reflector
- Linear Cross-Polarized Feed
- BUC and Integral SSPA (sometimes called SSPB)
- LNB
- Antenna Controller
 - Antenna Controller computer
 - Human Machine Interface
 - GPS
 - Inertial Navigation system
 - Signal Tracking Assistance

³ Per FCC 25.226 Blanket licensing provisions for domestic, U.S. Vehicle-Mounted Earth Stations (VMESs) receiving in the 10.95–11.2 GHz (space-to-Earth), 11.45–11.7 GHz (space-to-Earth), and 11.7–12.2 GHz (space-to-Earth) frequency bands and transmitting in the 14.0–14.5 GHz (Earth-to-space) frequency band, operating with Geostationary Satellites in the Fixed-Satellite Service.

The antenna controller utilizes GPS, an advanced inertial navigation system (INS), and knowledge of the satellite ephemeris (knowledge box) to compute the pointing for the antenna.

The L3/Datron FSS-4180-LC Antenna Assembly is a two axis (Azimuth, Elevation) antenna and Polarization feed adjusting pedestal. The antenna is symmetrical in its azimuth plane and its elevation plane.

The Antenna Reflector, shown in [Figure 9](#), is approximately 17.4" x 17.4" (0.44m x 0.44m).

Figure 9. 18" Antenna Reflector Photo.



2.3.4 Management

The Master/Hub fixed earth station acts as a Network Controller (NC) and mobile earth stations are Network Members (NM). The operation of the mobile earth station or Network Member (NM) is fully managed by master/hub earth station Network Controller (NC).

No transmission occurs without the NM locking on to a NC carrier and receiving assignments. Transmissions are burst from NM as assigned and transmission ceases if assignments are not needed or not granted.

Mobile earth station performance will be monitored by personnel during operations. Personnel have the ability to disable transmission of the NM (and NC) earth station if necessary.

2.3.5 Contention Channel

A contention access channel is used for signaling communications between the mobile earth station and the hub. A detailed analysis of the contention channel performance is provided in a separate Contention Channel document [4]. FCC

rules and proposed rules have been reviewed in order to determine requirements for usage of contention channels.

During steady state operation, contention channel registrations occur seldom but collisions could occur. These collisions would be occasional bursts of duration 1.3 to 42 ms (less than the 100 ms recommended⁴ (Para 71)).

The contention channel use complies with Table-5⁵ and thus should be considered “reasonable use” per the FCC guidelines.

2.3.6 Data Logging

In support of FCC rules, the NM will log⁶ time, location, and transmission details that could be made available in support of resolving interference events

Additional information on the data logging provisions is included in:

[6 APPENDIX – DATA LOGGING.](#)

2.3.7 Disable Provisions

The following disable provisions described in

[7 APPENDIX - DISABLE PROVISIONS](#) are available and enabled by default:

- RF Mute on Pointing Error
- Self-Monitor Conditions for Modem Transmission
- Mute on Loss of Lock
- Temporarily Disable Remote NM
- Permanent Disable Remote NM

⁴ FCC 08-246, “Eighth Report and Order on Reconsideration, 2000 Biennial Regulatory Review Streamlining and Other Revisions of Part 25 of the Commission's Rules Governing the Licensing of, and Spectrum Usage by, Satellite Network Earth Stations and Space Stations”, IB Docket No. 00-248, IB Docket No. 95-117, FCC Document, October 17, 2008

⁵ FCC 08-246 EIGHTH REPORT AND ORDER [1]

⁶ Data logging capability is not available at the time of writing this document, but is intended to be available in a future revision. Only mobile earth stations with the data logging will be used under the requested license.

3 ANTENNA

The antenna is a center fed feed Cassegrain controlled by a high performance positioner utilizing inertial navigation and GPS.

3.1 Gain Patterns

A sample transmit plot is shown in [Figure 10](#). The antenna gain is plotted in green, the FCC 25.209 gain curve is plotted in blue. These plots were created from actual antenna range data as provided in [Table 1](#).

Table 1. Antenna Gain Plots Assumption.

| Description | Value | Unit |
|--------------|------------|------|
| Frequency | 14.5 | GHz |
| Polarization | HORIZONTAL | |
| Axis | Azimuth | |
| Plane | H Plane | |
| Peak Gain | 35.6 | dBi |

Figure 10. Antenna Gain Plotted against FCC Standards 25.209 - $\pm 10^\circ$.

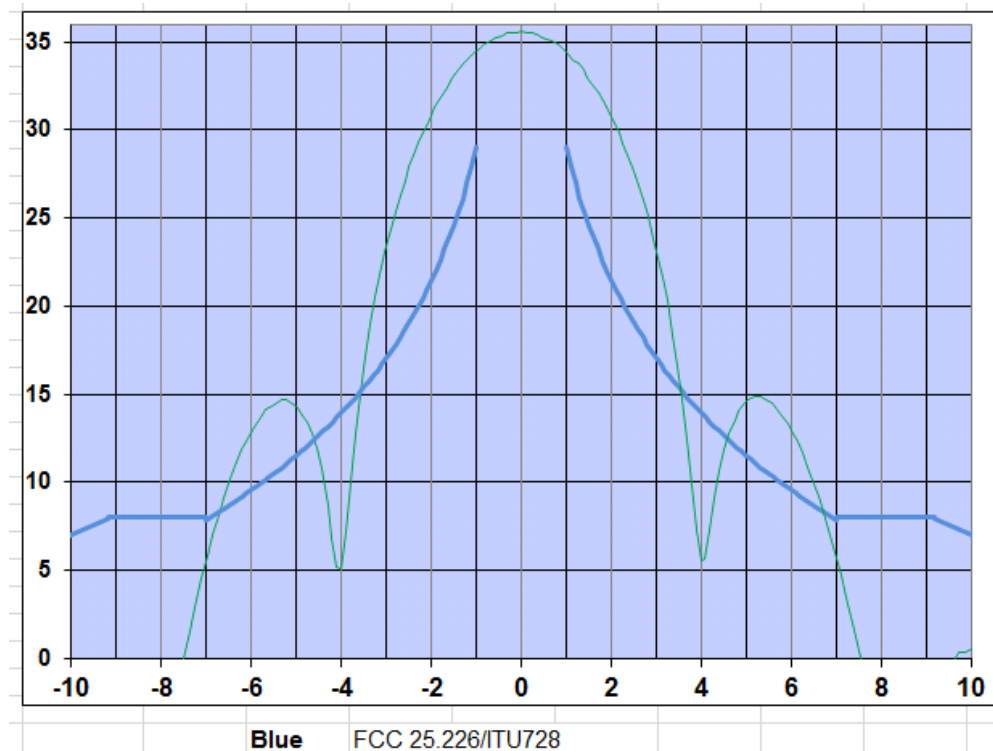

As noted and expected, the antenna does not meet the FCC Title 47 Part 25.209 in the main lobe and the first sidelobe. This is due to the small aperture of the main reflector.

3.2 EIRP Power Spectral Density (EPSD) Patterns

Since the terminal will not meet the $29-25\log \theta$ as indicated in **Gain Patterns**, the terminal must meet the off-axis EPSD as set forth under FCC Title 47 Part 25.226 for VMES terminals.

(1) The following requirements shall apply to a VMES that uses transmitters with off-axis EIRP spectral-densities lower than or equal to the levels in paragraph (a)(1)(i) of this section. A VMES, or VMES system, operating under this section shall provide a detailed demonstration as described in paragraph (b)(1) of this section. The VMES transmitter also shall comply with the antenna pointing and cessation of emission requirements in paragraphs (a)(1)(ii) and (a)(1)(iii) of this section.

(i) A VMES system shall not exceed the off-axis EIRP spectral-density limits and conditions defined in paragraphs (a)(1)(i)(A) through (D) of this section.

A) The off-axis EIRP spectral-density emitted from the VMES, in the plane of the geostationary satellite orbit (GSO) as it appears at the particular earth station location, shall not exceed the following values:

$$15-10\log(N)-25\log\theta \text{ dBW/4kHz for } 1.5^\circ \leq \theta \leq 7^\circ$$

$$-6-10\log(N) \text{ dBW/4kHz for } 7^\circ < \theta \leq 9.2^\circ$$

$$18-10\log(N)-25\log\theta \text{ dBW/4kHz for } 9.2^\circ < \theta \leq 48^\circ$$

$$-24-10\log(N) \text{ dBW/4kHz for } 48^\circ < \theta \leq 85^\circ$$

$$-14-10\log(N) \text{ dBW/4kHz for } 85^\circ < \theta \leq 180^\circ$$

where theta (θ) is the angle in degrees from the line connecting the focal point of the antenna to the orbital location of the target satellite, the plane of the GSO is determined by the focal point of the antenna and the line tangent to the arc of the GSO at the orbital location of the target satellite. For VMES networks using frequency division multiple access (FDMA) or time division multiple access (TDMA) techniques, N is equal to one. For VMES networks using multiple co-frequency transmitters that have the same EIRP, N is the maximum expected number of co-frequency simultaneously transmitting VMES earth stations in the same satellite receiving beam. For the purpose of this section, the peak EIRP of an individual sidelobe shall not exceed the envelope defined above for θ between 1.5° and 7.0° . For θ greater than 7.0° , the envelope shall be exceeded by no more than 10% of the sidelobes, provided no individual sidelobe exceeds the envelope given above by more than 3 dB.

(B) In all directions other than along the GSO, the off-axis EIRP spectral-density for co-polarized signals emitted from the VMES shall not exceed the following values:

$$18-10\log(N)-25\log\theta \text{ dBW/4kHz for } 3.0^\circ \leq \theta \leq 48^\circ$$

$$-24-10\log(N) \text{ dBW/4kHz for } 48^\circ < \theta \leq 85^\circ$$

$$-14-10\log(N) \text{ dBW/4kHz for } 85^\circ < \theta \leq 180^\circ$$

where θ and N are defined in paragraph (a)(1)(i)(A) of this section. This off-axis EIRP spectral-density applies in any plane that includes the line connecting the focal point of the antenna to the orbital location of the target satellite with the exception of the plane of the GSO as defined in paragraph (a)(1)(i)(A) of this section. For the purpose of this subsection, the envelope shall be exceeded by no more than 10% of the sidelobes provided no individual sidelobe exceeds the gain envelope given above by more than 6 dB. The region of the main reflector spillover energy is to be interpreted as a single lobe and shall not exceed the envelope by more than 6 dB.

(C) In all directions, the off-axis EIRP spectral-density for cross-polarized signals emitted from the VMES shall not exceed the following values:

$$5-10\log(N)-25\log\theta \text{ dBW/4kHz for } 1.8^\circ \leq \theta \leq 7.0^\circ$$

$$-16-10\log(N) \text{ dBW/4kHz for } 7.0^\circ < \theta \leq 9.2^\circ$$

where θ and N are defined as set forth in paragraph (a)(1)(i)(A) of this section. This EIRP spectral-density applies in any plane that includes the line connecting the focal point of the antenna to the target satellite.

3.2.1 Use of Direct Sequence Spread Spectrum (DSSS)

DSSS will be employed to meet the 25.226 EPSD rule. The RMPM-1000 modem includes 16 levels of spreading, (0 to 12 dB PSD reduction range). **Table 2** provides a complete (VMES to hub) DSSS range assuming a maximum

P_{lin} of 44.5 dBW (see [Figure 6](#)) and 1024 kbps (BPSK and $\frac{1}{2}$ coding). The highlighted row indicates that a DSSS spread of 4 is needed to meet ESPD.

Table 2. Meeting ESPD per 25.226 using DSSS.

| Antenna | Max EIRP | Data Rate (kbps) | Modulation | FEC Code | Rate (kbps) | Pwr B/W Multiplier | DSSS Spreading | | dBW/4 |
|----------------------|-------------|------------------|-------------|------------|----------------|--------------------|----------------|------------|-------------|
| | | | | | | | Multiplier | dB | |
| FSS-4180-LC | 44.5 | 1024000 | BPSK | 1/2 | 2048000 | 1.2 | 1 | 0.0 | 16.6 |
| FSS-4180-LC | 44.5 | 1024000 | BPSK | 1/2 | 2048000 | 1.2 | 2 | 3.0 | 13.6 |
| FSS-4180-LC | 44.5 | 1024000 | BPSK | 1/2 | 2048000 | 1.2 | 3 | 4.8 | 11.8 |
| FSS-4180-LC | 44.5 | 1024000 | BPSK | 1/2 | 2048000 | 1.2 | 4 | 6.0 | 10.6 |
| FSS-4180-LC | 44.5 | 1024000 | BPSK | 1/2 | 2048000 | 1.2 | 5 | 7.0 | 9.6 |
| FSS-4180-LC | 44.5 | 1024000 | BPSK | 1/2 | 2048000 | 1.2 | 6 | 7.8 | 8.8 |
| FSS-4180-LC | 44.5 | 1024000 | BPSK | 1/2 | 2048000 | 1.2 | 7 | 8.5 | 8.2 |
| FSS-4180-LC | 44.5 | 1024000 | BPSK | 1/2 | 2048000 | 1.2 | 8 | 9.0 | 7.6 |
| FSS-4180-LC | 44.5 | 1024000 | BPSK | 1/2 | 2048000 | 1.2 | 9 | 9.5 | 7.1 |
| FSS-4180-LC | 44.5 | 1024000 | BPSK | 1/2 | 2048000 | 1.2 | 10 | 10.0 | 6.6 |
| FSS-4180-LC | 44.5 | 1024000 | BPSK | 1/2 | 2048000 | 1.2 | 11 | 10.4 | 6.2 |
| FSS-4180-LC | 44.5 | 1024000 | BPSK | 1/2 | 2048000 | 1.2 | 12 | 10.8 | 5.8 |
| FSS-4180-LC | 44.5 | 1024000 | BPSK | 1/2 | 2048000 | 1.2 | 13 | 11.1 | 5.5 |
| FSS-4180-LC | 44.5 | 1024000 | BPSK | 1/2 | 2048000 | 1.2 | 14 | 11.5 | 5.2 |
| FSS-4180-LC | 44.5 | 1024000 | BPSK | 1/2 | 2048000 | 1.2 | 15 | 11.8 | 4.9 |
| FSS-4180-LC | 44.5 | 1024000 | BPSK | 1/2 | 2048000 | 1.2 | 16 | 12.0 | 4.6 |
| FSS-4180-LC | 43.3 | 768000 | BPSK | 1/2 | 1536000 | 1.2 | 1 | 0.0 | 16.6 |
| FSS-4180-LC | 43.3 | 768000 | BPSK | 1/2 | 1536000 | 1.2 | 2 | 3.0 | 13.6 |
| FSS-4180-LC | 43.3 | 768000 | BPSK | 1/2 | 1536000 | 1.2 | 3 | 4.8 | 11.8 |
| FSS-4180-LC | 43.3 | 768000 | BPSK | 1/2 | 1536000 | 1.2 | 4 | 6.0 | 10.6 |
| FSS-4180-LC * | 42.1 | 512000 | BPSK | 1/2 | 1024000 | 1.2 | 1 | 0.0 | 17.2 |
| FSS-4180-LC * | 42.1 | 512000 | BPSK | 1/2 | 1024000 | 1.2 | 2 | 3.0 | 14.2 |
| FSS-4180-LC * | 42.1 | 512000 | BPSK | 1/2 | 1024000 | 1.2 | 3 | 4.8 | 12.4 |
| FSS-4180-LC * | 42.1 | 512000 | BPSK | 1/2 | 1024000 | 1.2 | 4 | 6.0 | 11.2 |
| FSS-4180-LC * | 42.1 | 512000 | BPSK | 1/2 | 1024000 | 1.2 | 5 | 7.0 | 10.2 |
| FSS-4180-LC * | 42.1 | 512001 | BPSK | 1 1/2 | 1024002 | 1.2 | 6 | 7.8 | 9.4 |

* Actual Link Budgets using Telstar 14 and Hub/VMES located in Ft Lewis, Washington.

Link budget analysis as shown in [5 APPENDIX – SAMPLE LINK BUDGET](#) requires 42.1 dBW EIRP with 512 kbps data rate, BPSK, and $\frac{1}{2}$ Turbo code rate. This is shown in [Table 2](#), and in order to meet ESPD, a spread of between 4 or 5 is required.

Sample EIRP PSD and Xpol plots are shown in [Figure 11](#), [Figure 12](#), [Figure 13](#) and [Figure 14](#). These plots are for H/V Polarization and AZ/EL Axis, respectively, for 13.84 GHz. EIRP PSD and cross-pol PSD are managed such that the FCC 25.226 requirements are met. Spectral spreading is managed to ensure compliance with FCC25.226.

A complete set of EIRP PSD plots and tabular data vs. FCC 25.226 are shown in documents [2, 3] listed in the references section of this document.

Figure 11. H Pol, AZ Axis

Off-Axis 13.84 GHz, H Pol, AZ Axis, Max EIRP PSD = 11 dBW/4 kHz
+10° +180°

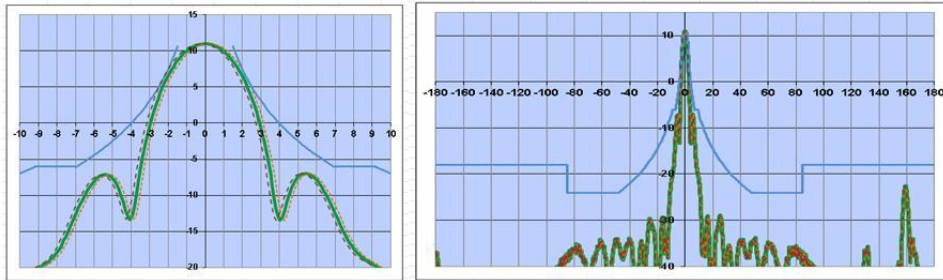

Off-Axis Cross Pol 13.84 GHz, H Pol, AZ Axis, Max EIRP PSD = 11 dBW/4 kHz

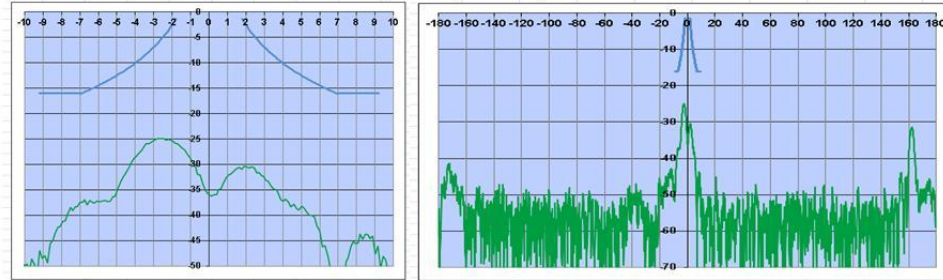

LEGEND

Green = EIRP PSD; Red (small dash) = +0.2°; Purple (larger dash) = -0.2°; Blue = FCC 25.226

Figure 12. H Pol, EL Axis

Off-Axis 13.84 GHz, H Pol, EL Axis, Max EIRP PSD = 11 dBW/4 kHz
±10° ±180°

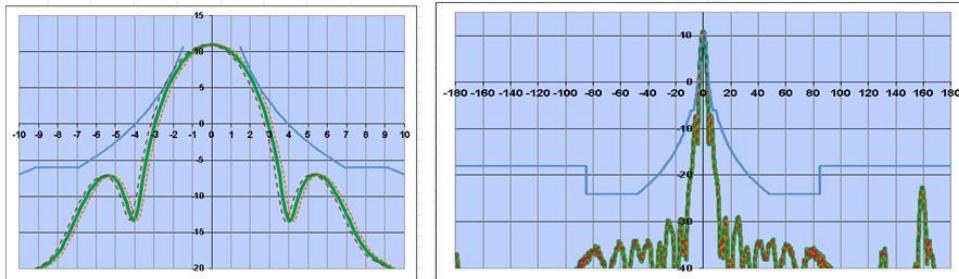

Off-Axis 13.84 GHz, H Pol, EL Axis, Max EIRP PSD = 11 dBW/4 kHz
±10° ±180°

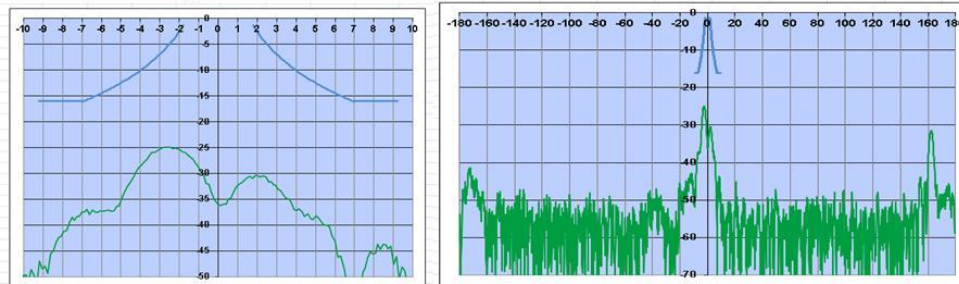

LEGEND

Green = EIRP PSD; Red (small dash) = +0.2°; Purple (larger dash) = -0.2°; Blue = FCC 25.226

Figure 13. V Pol, AZ Axis

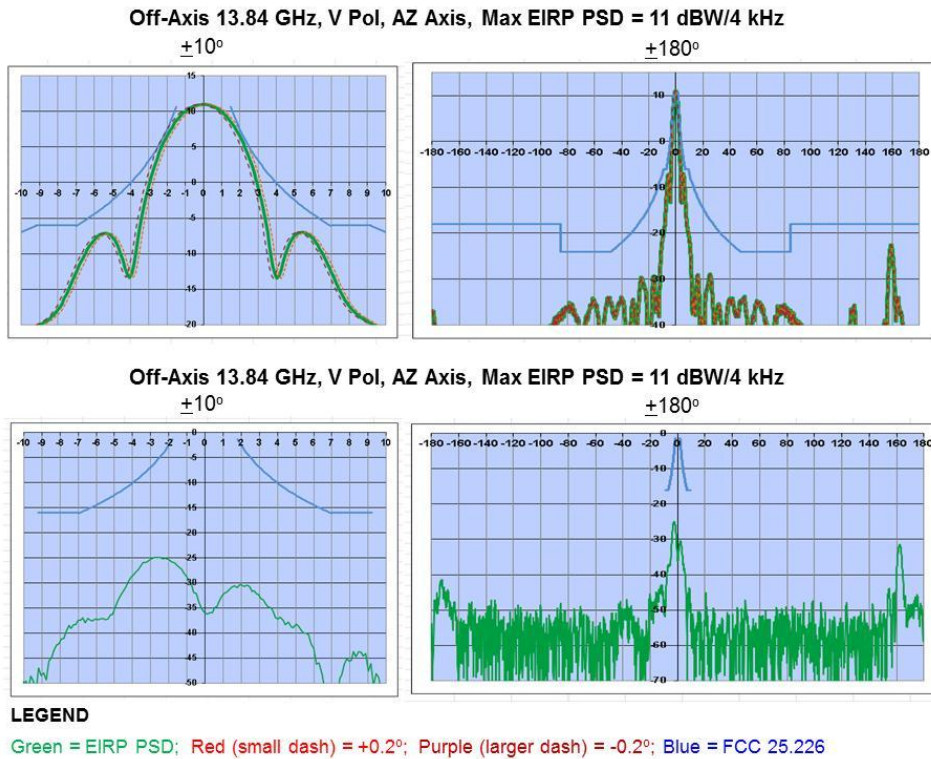
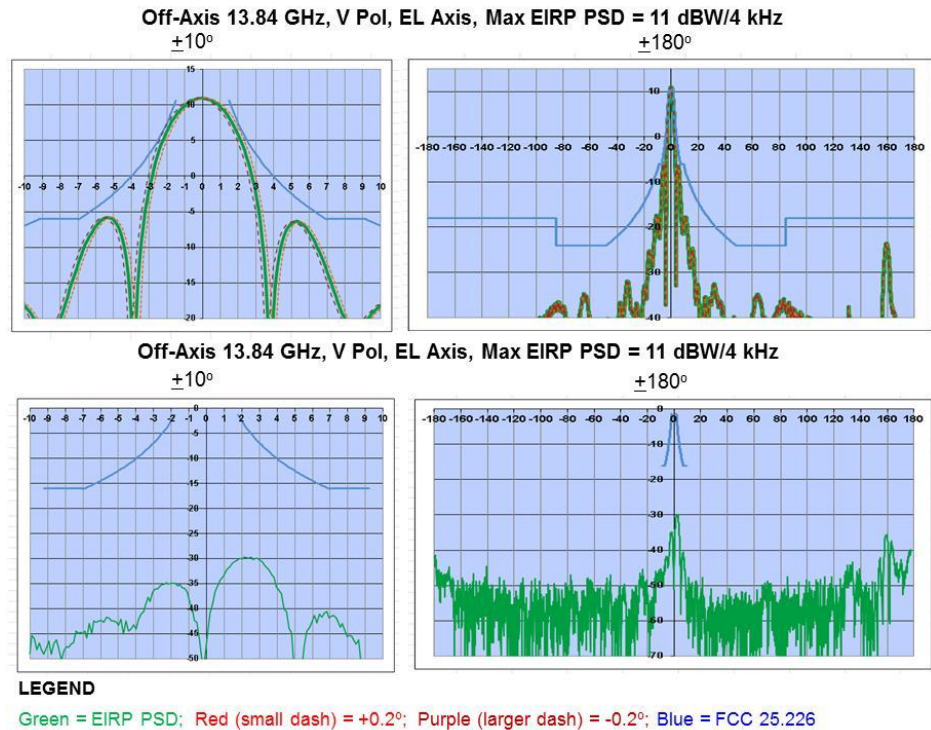

Figure 14. V Pol, EL Axis





3.3 Pointing Error

A detailed discussion of antenna pointing is provided in the **8 APPENDIX - ANTENNA POINTING ANALYSIS**. The FSS-4180-LC antenna system maintains **± 0.2 degrees pointing accuracy** 99% of the time (> 3 sigma) in a ground mobile operation on the Churchville B course. The antenna system is designed to mute the transmitter if the pointing error exceeds a configurable limit (factory set to 0.5 degrees).

4 TRANSMIT CARRIERS

Then RMPM-1000 is capable of operation at many bit rates, code rates, modulation types and spreading factors. Described herein are the carriers that cover the extremities in power and bandwidth for this system.

The **Mobile Earth Station (NM)** transmits three carrier types:

- Assigned
 - Reverse Orderwire (AROW)
 - Data Communications (DCOM)
- Contention Reverse Orderwire (CROW)

Only one carrier type is transmit at a time as defined by the multi-frequency time division multiple access MF-TDMA frame structure (N=1).

The **Master/Hub (NC) Earth Station** transmits two carrier types:

- Assigned
 - Forward Orderwire (FOW)
 - Data Communications (DCOM)

Only one carrier type is transmitted at a time as defined by the multi-frequency time division multiple access MF-TDMA frame structure (N=1).

4.1 Mobile Earth Station Carriers

4.1.1 Assigned Carriers (AROW, DCOM)

Assigned carriers include the AROW and the DCOM. Details are provided in [4].

Transmit carriers from the mobile earth station will be BPSK with spread spectrum to ensure compliance with the FCC 25.226 ruling. The emission designations are as shown in [Table 3](#).

Table 3. Emission designations for VMES to Hub Communications.

| Carrier Type | Transmit | Receive | Emission | Emission BW (Hz) |
|--------------------------|----------|---------|----------|------------------|
| min bit rate, min spread | 1T | 1R | 45K0G7D | 45,000 |
| min bit rate, max spread | 2T | 2R | 717KG7D | 717,000 |
| max bit rate, min spread | 3T | 3R | 1M4G7D | 1,430,000 |
| max bit rate, max spread | 5T | 5R | 11M5G7D | 11,500,000 |

4.1.2 Contention Carrier (CROW)

The contention carrier is the CROW. A slotted Aloha scheme with collision detection is used. Details are provided in [4].

The contention transmit carrier types from the mobile earth station are identical to the assigned carrier types. If collisions are detected in the contention channel, then the spread factor may be increased and/or the number of contention

channel time slots may be increased. The increase in aggregate EIRP density is within the FCC guidelines discussed in [1.2 Referenced Documents](#) [4].

The contention channel use complies with Table-5⁷ and thus should be considered “reasonable use” per the FCC guidelines.

4.2 Master/Hub Earth Station Carriers

Assigned carriers include the FOW and the DCOM. Details are provided in the appendix (see Chapter 12 APPENDIX – CONTENTION CHANNEL).

Transmit carriers from the master/hub earth station will be BPSK or QPSK. The emission designations are shown in [Table 4](#):

Table 4. Emission Designations for Hub to VMES Communications.

| Transmit | Receive | Emission | Emission BW (Hz) |
|----------|---------|----------|------------------|
| 1T | 1R | 45K0G7D | 45,000 |
| 2T | 2R | 717KG7D | 717,000 |
| 3T | 3R | 1M4G7D | 1,430,000 |
| 5T | 5R | 11M5G7D | 11,500,000 |

4.3 Transmit Carrier

4.3.1 VMES Transmit

The VMES will transmit one and only one MF-TDMA BPSK carrier with a data rate from 32 kbps up to 4.096 Mbps. The actual transmission rate will depend on the customer needs, terminal maximum EIRP, link needs, and compliance with FCC25.226.

The carrier attributes will be assigned by the Network Controller. The spectrum will be used by only one transmitter at a time (N=1). No CDMA will be used. A contention based protocol is used for initial access.

Occupied bandwidth is 1.4 times the symbol rate.

4.3.2 Hub Transmit

The hub will transmit one or more BPSK or QPSK carriers with a data rate from 32 kbps up to 4.096 Mbps. The actual transmission rate will depend on the customer needs, terminal maximum EIRP, and link needs.

The carrier attributes will be assigned by the Network Controller. The spectrum will be used by only one transmitter at a time (N=1). No CDMA will be used. A contention based protocols is used for initial access.

Occupied bandwidth is 1.4 times the symbol rate.

⁷ FCC 08-246 EIGHTH REPORT AND ORDER [1]

5 APPENDIX – SAMPLE LINK BUDGET

A sample link budget has been prepared below for the following remote to hub carrier:

- Transmit/Receive Locations = Fort Lewis, Washington @ Long = 47.11° N; Lat = 122.56° W
- Satellite = Telstar 14R, CONUS Beam @ 63° West Longitude (see [Figure 15](#) for EIRP Footprint)
- Data Rate = 512 kbps
- Code Rate/FEC Type = R1/2 FEC (Turbo)
- Modulation = BPSK
- Required Eb/No = 3.3 dB
- Rain Fade = Crane C Model
- Link Availability = 99.9%

The results of these link budgets are shown below:

- An uplink EIRP of 42.57 dBW is required
- A spreading factor of between 4x and 5x is required

Figure 15. Telstar 14 EIRP CONUS, Coastal and Caribbean EIRP Footprint.

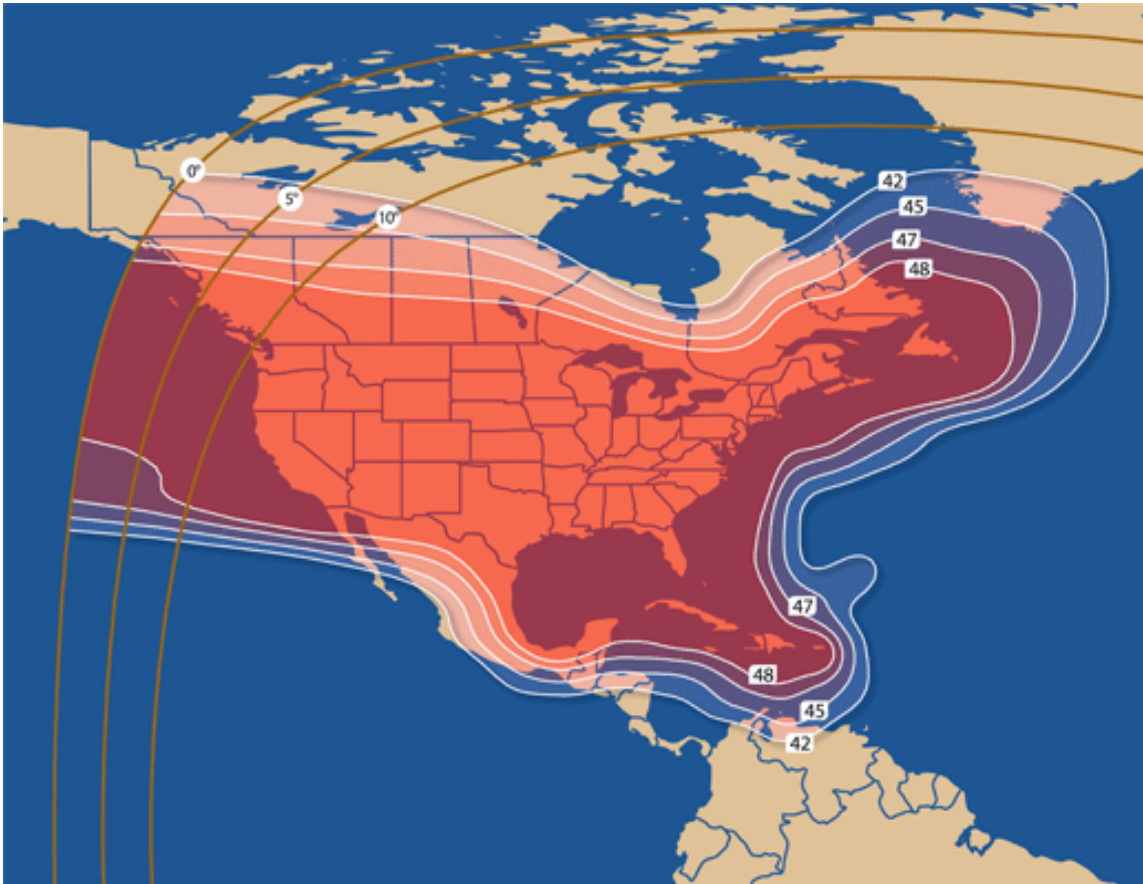



Digital Link Budget
Produced using Satmaster Pro
Wednesday, October 31, 2012

| | |
|------------------------|---|
| Service Name | Telstar 14 |
| Coverage | CONUS Beam, Turbo Coded |
| Uplink earth station | Fort Lewis, Washington 18" VMES Antenna |
| Downlink earth station | Fort Lewis, Washington 3.9 Meter Hub |
| Satellite name | Estrela do Sul-1 |

| Link Input Parameters | Up | Down | Units |
|------------------------------------|------------|------------|------------------|
| Site latitude | 47.1144N | 47.1144N | degrees |
| Site longitude | 122.56W | 122.56W | degrees |
| Site altitude | 00 | 00 | km |
| Frequency | 14.250 | 11.950 | GHz |
| Polarization | Horizontal | Vertical | |
| Rain model | ITU (35.5) | ITU (35.5) | (mm/h or zone) |
| Availability (average year) | 99.9 | 99.9 | % |
| Antenna aperture | 0.45 | 3.8 | metres |
| Antenna efficiency / gain | +34.6 | +51.2 | % (+ prefix dBi) |
| Coupling loss | 0.9 | 0.2 | dB |
| Antenna tracking / mispoint error | .2 | .2 | dB |
| LNB noise figure / temp | | +55 | dB (+ prefix K) |
| Antenna noise | | 60 | K |
| Adjacent carrier interference | 25 | 40 | dB |
| Adjacent satellite interference | 25 | 25 | dB |
| Cross polarization interference | 25 | 30 | dB |
| Uplink station HPA output back-off | 2 | | dB |
| Number of carriers / HPA | 1 | | |
| HPA C/M (up) | 50 | | dB |
| Uplink power control | 0 | | dB |
| Uplink filter truncation loss | 0 | | dB |
| Required HPA power capability | MIN | | W |



| Satellite Input Parameters | Value | Units |
|--------------------------------|--------|---------|
| Satellite longitude | 63.00W | degrees |
| Transponder type | TWTA | |
| Receive G/T | 4 | dB/K |
| Saturation flux density | -107 | dBW/m2 |
| Satellite attenuator pad | 5 | dB |
| Satellite ALC | 0 | dB |
| EIRP (saturation) | 48 | dBW |
| Transponder bandwidth | 36 | MHz |
| Input back off total | 7 | dB |
| Output back off total | AUTO | dB |
| Intermodulation interference | AUTO | dB |
| Number of transponder carriers | AUTO | |

| Carrier/Link Input Parameters | Value | Units |
|---|------------------|-------|
| Modulation | BPSK | |
| Required bit error rate performance | 10 ⁻⁸ | |
| Required Eb/No without FEC coding | 11.97 | dB |
| Required Eb/No with FEC coding | 3.3 | dB |
| Information rate | 0.512 | Mbps |
| Overhead | 0 | % |
| FEC code rate | .512 | |
| Spreading gain | 0 | dB |
| Reed Solomon code (1 + Roll off factor) | 1 | |
| Carrier spacing factor | 1.2 | |
| Bandwidth allocation step size | 1.4 | |
| System margin | 0.01 | MHz |
| | 0.5 | dB |

| Calculations at Saturation | Value | Units |
|----------------------------|-------|-------|
| Gain 1m ² | 44.53 | dB/m2 |
| Uplink C/No | 86.07 | dB.Hz |
| Downlink C/No | 99.10 | dB.Hz |
| Total C/No | 85.86 | dB.Hz |
| Uplink EIRP for saturation | 62.75 | dBW |

| General Calculations | Up | Down | Units |
|------------------------------|----------|----------|---------|
| Elevation | 11.72 | 11.72 | degrees |
| True azimuth | 113.30 | 113.30 | degrees |
| Compass bearing | 96.13 | 96.13 | degrees |
| Path distance to satellite | 40409.06 | 40409.06 | km |
| Propagation time delay | 0.134790 | 0.134790 | seconds |
| Antenna efficiency | 63.87 | 58.22 | % |
| Antenna gain | 34.60 | 51.20 | dBi |
| Availability (average year) | 99.9 | 99.9 | % |
| Link downtime (average year) | 8.766 | 8.766 | hours |
| Availability (worst month) | 99.615 | 99.615 | % |
| Link downtime (worst month) | 2.809 | 2.809 | hours |
| Spectral power density | -52.83 | -30.39 | dBW/Hz |



| Uplink Calculation | Clear | Rain Up | Rain Dn | Units |
|------------------------------------|--------------|----------------|----------------|--------------|
| Uplink transmit EIRP | 42.57 | 42.57 | 42.57 | dBW |
| Transponder input back-off (total) | 7.00 | 7.00 | 7.00 | dB |
| Input back-off per carrier | 20.18 | 24.50 | 20.18 | dB |
| Mispoint loss | 0.20 | 0.20 | 0.20 | dB |
| Free space loss | 207.65 | 207.65 | 207.65 | dB |
| Atmospheric absorption | 0.34 | 0.34 | 0.34 | dB |
| Tropospheric scintillation fading | 1.09 | 1.09 | 1.09 | dB |
| Atmospheric losses total | 1.43 | 1.43 | 1.43 | dB |
| Total path loss (excluding rain) | 209.08 | 209.08 | 209.08 | dB |
| Rain attenuation | 0.00 | 4.31 | 0.00 | dB |
| Uplink power control | 0.00 | 0.00 | 0.00 | dB |
| Uncompensated rain fade | 0.00 | 4.31 | 0.00 | dB |
| C/No (thermal) | 65.88 | 61.57 | 65.88 | dB.Hz |
| C/N (thermal) | 5.09 | 0.78 | 5.09 | dB |
| C/ACI | 25.00 | 20.69 | 25.00 | dB |
| C/ASI | 25.00 | 20.69 | 25.00 | dB |
| C/XPI | 25.00 | 20.69 | 25.00 | dB |
| C/IM | 50.00 | 50.00 | 50.00 | dB |
| Eb/(No+Io) | 8.66 | 4.35 | 8.66 | dB |

| Downlink Calculation | Clear | Rain Up | Rain Dn | Units |
|-------------------------------------|--------------|----------------|----------------|--------------|
| Satellite EIRP total | 48.00 | 48.00 | 48.00 | dBW |
| Transponder output back-off (total) | 4.41 | 4.41 | 4.41 | dB |
| Output back-off per carrier | 17.60 | 21.91 | 17.60 | dB |
| Satellite EIRP per carrier | 30.40 | 26.09 | 30.40 | dBW |
| Mispoint loss | 0.20 | 0.20 | 0.20 | dB |
| Free space loss | 206.12 | 206.12 | 206.12 | dB |
| Atmospheric absorption | 0.29 | 0.29 | 0.29 | dB |
| Tropospheric scintillation fading | 0.90 | 0.90 | 0.90 | dB |
| Atmospheric losses total | 1.19 | 1.19 | 1.19 | dB |
| Total path loss (excluding rain) | 207.31 | 207.31 | 207.31 | dB |
| Rain attenuation | 0.00 | 0.00 | 3.06 | dB |
| Noise increase due to precipitation | 0.00 | 0.00 | 3.05 | dB |
| Downlink degradation (DND) | 0.00 | 0.00 | 6.11 | dB |
| Total system noise | 125.35 | 125.35 | 252.93 | K |
| Figure of merit (G/T) | 29.82 | 29.82 | 26.77 | dB/K |
| C/No (thermal) | 81.50 | 77.19 | 75.40 | dB.Hz |
| C/N (thermal) | 20.71 | 16.40 | 14.61 | dB |
| C/ACI | 40.00 | 35.69 | 40.00 | dB |
| C/ASI | 25.00 | 20.69 | 25.00 | dB |
| C/XPI | 30.00 | 25.69 | 30.00 | dB |
| C/IM | 15.20 | 10.89 | 15.20 | dB |
| Eb/(No+Io) | 17.37 | 13.06 | 15.30 | dB |



| Totals per Carrier (End-to-End) | Clear | Rain Up | Rain Dn | Units |
|---------------------------------|-------|---------|---------|-------|
| C/No (thermal) | 65.77 | 61.45 | 65.42 | dB.Hz |
| C/N (thermal) | 4.97 | 0.66 | 4.63 | dB |
| C/ACI | 24.86 | 20.55 | 24.86 | dB |
| C/ASI | 21.99 | 17.68 | 21.99 | dB |
| C/XPI | 23.81 | 19.50 | 23.81 | dB |
| C/IM | 15.20 | 10.89 | 15.20 | dB |
| C/(No+Io) | 65.20 | 60.89 | 64.90 | dB.Hz |
| C/(N+I) | 4.41 | 0.10 | 4.11 | dB |
| Eb/(No+Io) | 8.11 | 3.80 | 7.81 | dB |
| System margin | 0.50 | 0.50 | 0.50 | dB |
| Net Eb/(No+Io) | 7.61 | 3.30 | 7.31 | dB |
| Required Eb/(No+Io) | 3.30 | 3.30 | 3.30 | dB |
| Excess margin | 4.31 | 0.00 | 4.01 | dB |

| Earth Station Power Requirements | Value | Units |
|---------------------------------------|---------|--------|
| EIRP per carrier | 42.57 | dBW |
| Antenna gain | 34.60 | dB |
| Antenna feed flange power per carrier | 7.97 | dBW |
| Uplink power control | 0.00 | dB |
| HPA output back off | 2.00 | dB |
| Waveguide loss | 0.9 | dB |
| Filter truncation loss | 0 | dB |
| Number of HPA carriers | 1 | |
| Total HPA power required | 10.8659 | dBW |
| Required HPA power capability | 12.2065 | W |
| Spectral power density | -52.83 | dBW/Hz |

| Space Segment Utilization | Value | Units |
|---------------------------------------|--------|---------|
| Overall link availability | 99.800 | % |
| Information rate (inc overhead) | 0.5120 | Mbps |
| Transmit rate | 1.0000 | Mbps |
| Symbol rate | 1.0000 | Mbaud |
| Occupied bandwidth | 1.2000 | MHz |
| Noise bandwidth | 60.79 | dB.Hz |
| Minimum allocated bandwidth required | 1.4000 | MHz |
| Allocated transponder bandwidth | 1.4000 | MHz |
| Percentage transponder bandwidth used | 3.89 | % |
| Used transponder power | 30.40 | dBW |
| Percentage transponder power used | 4.80 | % |
| Max carriers by transponder bandwidth | 25.71 | |
| Max carriers by transponder power | 20.82 | |
| Max transponder carriers limited by:- | Power | [20.82] |
| Power equivalent bandwidth usage | 1.73 | MHz |

6 APPENDIX – DATA LOGGING

This section provides a review of FCC requirements for data logging within a sub-meter Satcom-on-the-move system.

6.1 Requirements

FCC requirements for the Satcom on the move system are stated in FCC25.226 and are repeated here for convenience.

(b)(7) Any VMES applicant filing for a VMES terminal or system shall include in its application a certification that will comply with the requirements of paragraph **(a)(6)** of this section.

(a)(6) For each VMES transmitter, a **record** of the vehicle location (i.e., latitude/longitude), transmit frequency, channel bandwidth and satellite used shall be time annotated and maintained for a period of not less than one (1) year.

Records shall be recorded at time intervals no greater than every five (5) minutes while the VMES is transmitting.

The VMES operator shall make this data available upon request to a coordinator, fixed system operator, fixed-satellite system operator, NTIA, or the Commission within 24 hours of the request.

6.2 Compliance

The L3 system will comply with the FCC25.226 (b)(7) requirements for data logging.

The Army's WIN-T program is a deployable network that utilizes Satcom on The Move terminals (SOTM). This SOTM consist of an 18" VSAT antenna type that may be on a variety vehicles (HMMWV, MRAP etc.). This is a small dish (sub-meter) with low power operating at either Ku or Military Ka bands. Control of this network is through the Army's Network Operations Center.

The WIN-T network uses a centralized Network Management System (NMS). The NMS monitors and controls local and remote components of the system. The NMS will pull information from remote mobile earth stations which contain the MPM-1000 modem, FSS4180 antenna controller, and remote GPS and inertial navigation equipment. The required data logging information will be maintained in the central NMS.

For commercial ku Band operations, the WIN-T program office will be the centralized repository of the required data. This office will be responsible for gathering and providing all data requested by the FCC. Data may be provided within 24 hours.



In compliance of FCC rules (FCC25.226), the WIN-T system will log time, location, and transmission details that can be made available in support of resolving interference events. This data logging capability and/or reporting to outside parties may be disabled by the system operator should the operator of the system seek and receive a waiver from the FCC of the data logging requirement for national security reasons.

1. The NMS will collect the following data, for a period of not less than one year, for each operational mobile earth station:
 - a. longitude and latitude,
 - b. transmit frequency,
 - c. bandwidth,
 - d. Satellite used.

Once collected the data will be transferred to the WIN-T program office.

2. Records shall be recorded at time intervals no greater than every 5 minutes while the mobile earth station is transmitting.
3. The WIN-T program office shall make data available, within 24 hours of the request, to a coordinator, fixed system operator, fixed-satellite system operator, NTIA, or the Commission.
4. The WIN-T program office shall maintain logs of all alleged incidences of interference, the stations involved, and the outcome of the incident.

The POC within the United States is the WIN-T program office whenever SNE ARMY terminals are in operation. They are:

Walter Hojsak or Tom Franey
PM WIN-T
6210 Frankford Street, Building 6210
Aberdeen Proving Grounds
Maryland 21005
Email: walter.j.hojsak.ctr@mail.mil,
walter.tfraney.civ@mail.mil

Telephone: 443 395 7210, 831 239 3810 (C)
732.532.3017

Any changes to these POCs will be provided to the FCC.

7 APPENDIX - DISABLE PROVISIONS

This section provides a description of the provisions to disable a terminal to avoid interference should it become defective.

Per FCC DA-09-587A⁸, under V. ORDERING CLAUSES, Paragraph 30:

- g) L-3 Communications's mobile earth station must be able to receive "enable transmission" and "disable transmission" commands from the network control center and must cease transmission immediately after receiving any "parameter change" command until it receives an "enable transmission" command from the network control center. The network control center will monitor operation of the L-3 Communications's mobile earth station to determine if it is malfunctioning, and the L-3 Communications's mobile earth station will self-monitor and automatically cease transmission upon detecting an operational fault that could cause harmful interference to the fixed-satellite service network.

7.1 RF Mute on Pointing Error

- The antenna system RF chain is muted upon power up.
- The Transmitter is only enabled if:
 - There are no faults
 - The upconverter is locked to the modem 10 MHz reference
 - The Inertial Navigation Unit is reporting that it is aligned
 - The antenna is pointed above a defined elevation horizon mask
 - The antenna is pointed at the target satellite
 - The feed is properly polarized
 - The servo interlock is not active
 - The antenna is enabled
 - The transmitter is enabled from the GUI

7.2 Self-Monitor Conditions for Modem Transmission

- The RMPM-1000 modem is muted during power up.
- An NM (Network Member) will not transmit until it has received and decoded the Forward Order Wire (FOW) broadcast. For this to be achieved, the terminal must be:
 - configured with the correct satellite, frequency, polarization, and security parameters
 - pointed to the correct satellite
 - aligned on the correct polarization
 - receiving on the correct frequency
 - able to establish correct timing

⁸ DA09-587, "Application for Authority to Operate a Mobile Earth Station to Provide Land Mobile Satellite Service in the Ku-Band", FCC Document, March 16, 2009.



- able to decrypt the Forward Order Wire (FOW) channel with the correct MSK key
- The NM obtains the frequency and time slots for the Contention Return Order Wire (CROW) channel
- An NM may transmit on the CROW channel subject to the controls placed on the use of the channel by the NC. Channel use is granted through messages in the FOW.
- Using the CROW channel, the NM may register with the NC. A correct Pass Key is required.
- If registration is successful, the NC grants the NM an Assigned Reverse Order Wire (AROW) for maintaining registration and for requesting assignments.
- No transmissions are permitted without assignments. All transmissions from NMs are assigned by the NC through the AROW (if registered) or the CROW (if not registered).

7.3 Mute on Loss of Lock

- If an NM cannot receive the FOW from the NC, then it is not permitted to transmit.

7.4 Temporarily Disable Remote NM

- The NC maintains a list of all registered Network Members (NMs).
- An operator at the NC may disconnect a registered NM to prevent it from transmitting
- The NM will not transmit without action from a local operator.
- The local operator may review the terminal condition, make a repair, and if appropriate may configure the terminal to re-connect or re-register if appropriate.

7.5 Permanent Disable Remote NM

- The NC maintains a list of all registered Network Members (NCs).
- An operator at the NC may disable a remote NM by zeroizing its MSK key
- Without an MSK key, the NM cannot recover the FOW, will never receive transmission assignments, and is not able to transmit
- A local operator will not be able to re-connect or re-register the NM without seeking a new and different MSK key from the network administrator.

8 APPENDIX - ANTENNA POINTING ANALYSIS

The L3/Datron FSS-4180-LC Antenna Assembly controls pointing of the antenna through the use of an embedded [Inertial Measurement Unit](#) (IMU), GPS updates, a digital beacon receiver, plus the response and stability of the gimbal's servos. This antenna pointing technology has been engineered over several years and has been verified in both lab and operational environments.

Vehicles may be subjected to a worst case environment described as the **Churchville B** test course (extreme rugged terrain). The L3/Datron FSS-4180-LC Antenna Assembly meets or exceeds its pointing objectives while subjected to the shock and vibration of this test course. It should be noted that while the system is designed and tested to this environment, vehicles will typically be subjected to a substantially less severe environment (paved or dirt roads) and as such the antenna pointing system will typically maintain pointing to tighter tolerances. The complete error must also factor in the IMU error component. Total error (99%) becomes 0.2° .

Antenna pointing errors arise from:

- **S = Signal Tracking Assistance Errors** – A signal tracking mechanism will measure signal strength and peak the antenna signal strength using receive signal strength measurements resulting from dynamic motion or dithering. Tracking error is $\pm 0.1^\circ$ and this eliminates Antenna Static errors (A) and Navigational errors (N).
- **A = Antenna** static errors due to mechanical alignment of the feed, reflector, and its relation to the inertial navigation system. Typically this error is $\pm 0.2^\circ$, but this is $\pm 0.0^\circ$ through the use of signal tracking assistance.
- **N = Navigational** system dynamic errors due to the motion of the inertial navigation system. Typically this error is $\pm 0.25^\circ$, but this is $\pm 0.0^\circ$ through the use of signal tracking assistance.
- **D = Dynamic** pointing errors between the desired pointing angle and the antenna pointing while in motion. ($\pm 0.2^\circ$, 99%, 3σ)

Total Error E = expected value of the uncorrelated events (S, A, N, D)

$$= \text{square root } (S^2 + A^2 + N^2 + D^2)$$

$$= \text{square root } ((0.1)^2 + 0^2 + 0^2 + (0.2)^2)$$

$$= \pm 0.2^\circ$$

Beyond $\pm 0.5^\circ$ the transmitter is muted in less than **100 ms** (per 47cfr25.226 requirements). Tracking errors and transmit mute are illustrated in [Figure 16](#).

Figure 16. Tracking Error from Boresight.

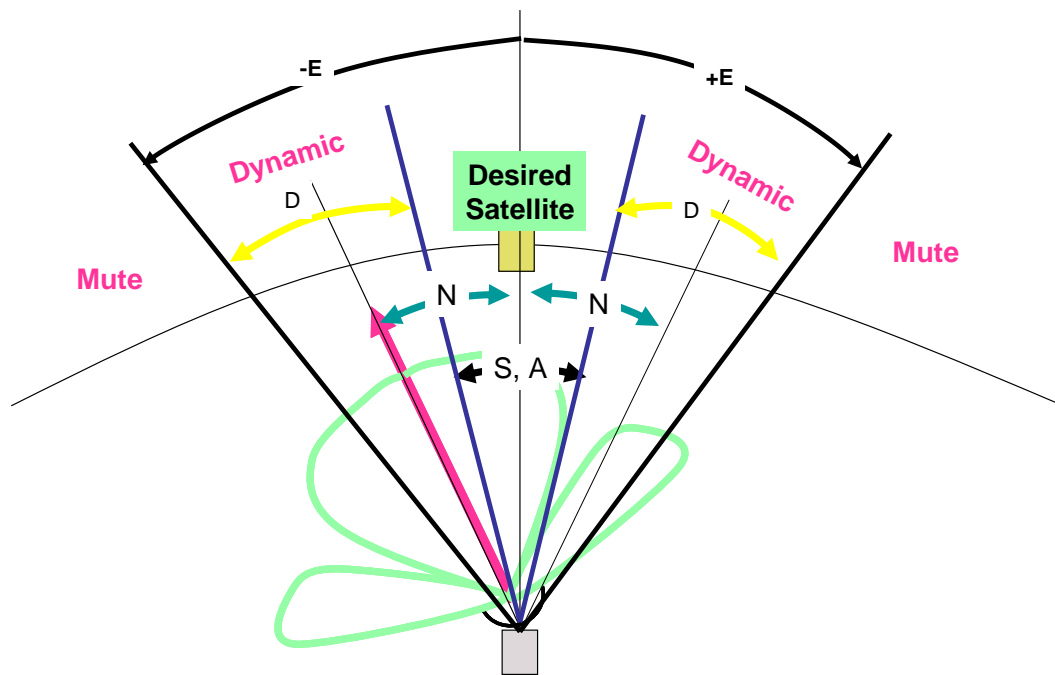

Figure 17 is a chart showing actual measured pointing error for 4000 sample points under simulated Churchville B mobile vehicle conditions.

Figure 17. Results of Churchville B course on a Motion Simulator.

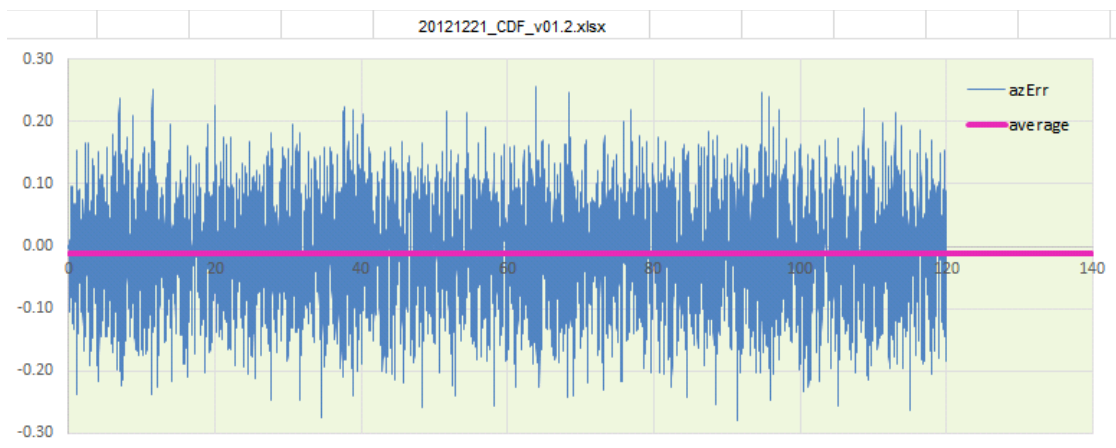
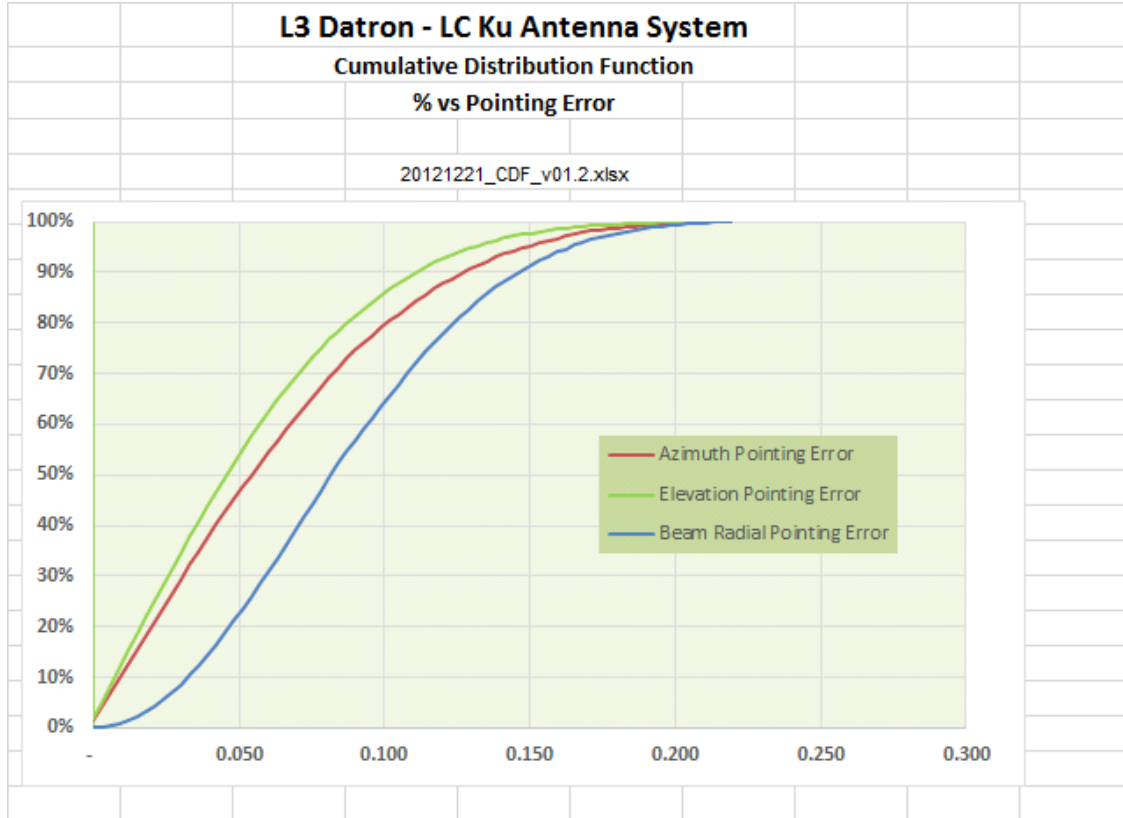

Figure 18 is the resulting Cumulative Distribution Function (CDF). 99% (3σ) of the time the dynamic pointing error is less than +/-0.2°degrees.

Figure 18. Cumulative Distribution Function.



Through the use of advanced control systems utilizing [Kalman filters](#) , GPS, inertial navigation systems, and various sensors, the total antenna pointing errors are maintained to the following absolute error +/-E:

| | |
|--|--|
| Antenna/Vehicle are NOT in motion | E<0.1° , 100% of the time Transmitter is Enabled |
| Antenna/Vehicle are in motion (paved or dirt roads) | E<0.2° Transmitter is Enabled |
| Extreme Terrain Churchville B mobile vehicle conditions | E<0.2° , 99% of the time Transmitter is Enabled |
| Antenna/Vehicle are in motion | E>0.5° Transmitter is MUTED |
| Note: Churchville B mobile vehicle conditions are the anticipated most extreme operational conditions. Typically the operational environment will be less severe. | |

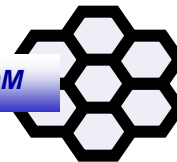

9 FSS-4180-LC Brochure

Datron Advanced Technologies

FSS-4000-LC COTM ANTENNA SYSTEM

THE AFFORDABLE KU/KA BAND GROUND-MOBILE SOLUTION

FSS-4000-LC COTM ANTENNA SYSTEM

The L-3 communications-on-the-move (COTM) antenna system supports 2-way VoIP, data, streaming video, as well as tactical military and commercial radio extension, over the toughest terrain. A combat proven vehicle mounted earth station (VMES) for use on wheeled and tracked vehicles, typical applications include: command and control (C²), emergency and first responders, border and civil patrols, news media and broadcasting. Available in multiple aperture sizes and frequency bands, the L-3 COTM Antenna System makes deploying your on-the-move (OTM) operations SIMPLE!



KEY FEATURES

- A 2-axis pedestal available with either a low profile or full circle aperture
- Supports Ku- and Ka-Band operation on a common pedestal providing deployment flexibility
- FCC and ITU compliant
- Its embedded ACU, IMU and beacon receiver simplifies installation on most platforms for near plug-n-play operation
- Modem agnostic, operates with any IP-based modem
- Qualified per MIL-STD-810F



C³ISR > GOVERNMENT SERVICES > AM&M > SPECIALIZED PRODUCTS



Datron Advanced Technologies

FSS-4000-LC COTM ANTENNA SYSTEM

THE AFFORDABLE KU/KA BAND GROUND-MOBILE SOLUTION

PERFORMANCE CHARACTERISTICS

| Model No. | Ku-Band | | Ka-Band | |
|------------------------------|---|----------------------|---|----------------------|
| | 4160-LC | 4180-LC | 4160-LC | 4180-LC |
| Aperture Size | 16 in (41 cm) | 18 in (46 cm) | 16 in (41 cm) | 18 in (46 cm) |
| RF Frequency | Rx: 10.95 to 12.75 GHz Tx: 13.75 to 14.50 GHz | | Rx: 20.20 to 21.20 GHz Tx: 30.00 to 31.00 GHz | |
| G/T | 11.4 dB/K | 12.4 dB/K | 12.0 dB/K | 12.8 dB/K |
| EIRP | 42.5 dBW | 43.5 dBW | 46.4 dBW | 47.4 dBW |
| Beamwidth | Rx: 3.9° Tx: 3.2° | Rx: 3.5° Tx: 2.9° | Rx: 2.2° Tx: 1.5° | Rx: 2.0° Tx: 1.3° |
| Polarization | Rx: Steered linear Tx: Orthogonal to Rx steered linear (polarization automatically steered) | | Rx: Circular polarized Tx: Orthogonally polarized to Rx (remotely selectable) | |
| Coverage: | Az: 360° continuous El: 0 to 90° | | Az: 360° continuous El: 0 to 90° | |
| Pointing Error | < 0.5 dB up to 70° elevation | | < 1 dB up to 70° elevation | |
| Satellite Reacquisition Time | < 5 sec | | < 5 sec | |
| Height (radome) | 17.5 in (44.5 cm) | 23.0 in (58.4 cm) | 17.5 in (44.5 cm) | 23.0 in (58.4 cm) |
| Base Footprint (min) | 26 x 26 in (66 x 66 cm) | | 26 x 26 in (66 x 66 cm) | |
| Weight | < 105 lbs (48 kg) | < 120 lbs (55 kg) | < 105 lbs (48 kg) | < 120 lbs (55 kg) |
| Environmental | Qualified to MIL-STD-810F | | Qualified to MIL-STD-810F | |
| Max Vehicle Speed | > 60 mph (100 km/hr) | | > 60 mph (100 km/hr) | |
| Power | 28 VDC, peak @ 750 W, continuous @ 450 W | | 28 VDC, peak @ 700 W, continuous @ 400 W | |

MODEL NUMBER DEVELOPMENT AND ORDERING

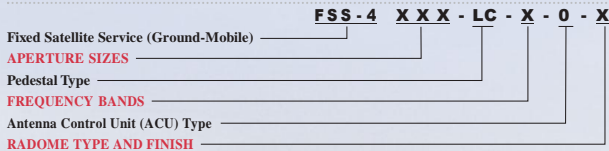

APERTURE SIZES

160 16.0 in / 41 cm
180 18.0 in / 46 cm

FREQUENCY BANDS

-1 Ku
-2 Ka

RADOME TYPE AND FINISH

-T Desert Tan, Multi-Band composite
-W Arctic White, Multi-Band composite
-G Forrest Green, Multi-Band composite
-TB Desert Tan, ballistic (band specific)
-WB Arctic White, ballistic (band specific)
-GB Forrest Green, ballistic (band specific)



Model No. FSS-4160-LC

Model No. FSS-4180-LC

Datron Advanced Technologies

200 West Los Angeles Avenue
Simi Valley, CA 93065-1650
Tel: 1.805.584.1717
Fax: 1.805.526.3690



communications
Datron Advanced Technologies

L-3. Headquartered in New York City, L-3 Communications employs over 64,000 people worldwide and is a prime contractor in aircraft modernization and maintenance, C³ISR (Command, Control, Communications, Intelligence, Surveillance and Reconnaissance) systems and government services. L-3 is also a leading provider of high technology products, subsystems and systems.

Cleared for public release by DoD/OSR under 09-S-3019 on October 6, 2009. Specifications subject to change without notice. Call for latest revision.
All brand names and product names referenced are trademarks, registered trademarks, or trade names of their respective holders. 10/09

10 RMPM-1000 Modem Brochure



Ruggedized MPM-1000 IP Modem Provides Military and Commercial Customers with the Specialized IP SATCOM Necessary to Keep Highly Mobile, Dispersed and Remote Users Connected



Linkabit's Ruggedized MPM-1000 Modem IP (RMPM) with its Network Centric Waveform (NCW) reduces operational cost and supports the highest number of IP users by providing very efficient use of Satellite Bandwidth over any Military or Commercial transponded satellite. The RMPM is a conduction-cooled unit that is environmentally sealed for optimal use in harsh environments. It has been tested and certified to meet all the requirements of the tactical environment. The RMPM is fully automated and once properly configured, requires no operator intervention if link conditions change, or if a different type terminal joins the network. It has been designed to utilize and optimize the full capabilities of the Wideband Global SATCOM (WGS) multi-beam, multi-band satellite.

The NCW is the U.S. Army's Open Standard (Non-Proprietary) Waveform that provides optimal performance in any SATCOM architecture with any size aperture terminal. It provides a fully certified secure network that is self forming and self healing making it very easy to use and maintain. Satellite resources can be managed on the battlefield or remote area with no special hub hardware required. Any large aperture terminal can operate as the Network Controller and there are allowances for automatic or planned Network Control handover.

With its rapid acquisition/reacquisition, hub assist functions and Doppler compensation, it provides outstanding support for COTM communications.

- **EFFICIENT USE OF SATELLITE RESOURCES**
 - ADVANCED MF-TDMA, DAMA SCHEDULER
 - ADAPTIVE CODING AND MODULATION
 - DIRECT SEQUENCE SPREADING ON A BURST-BY-BURST BASIS
 - SUPPORTS MESH, HUB-SPOKE AND HYBRID NETWORKS
 - SUPPORTS NON-CONTIGUOUS BANDWIDTHS IN MULTIPLE TRANSPONDERS
- **MEETS TACTICAL ENVIRONMENT**
 - DESIGNED TO MEET MIL-STD-810F AND MIL-STD-461
- **MAXIMUM THROUGHPUT WITH ANY SIZE TERMINAL IN A SINGLE NETWORK**
 - RESPONSIVE LINK POWER AND DATA RATE CONTROL
 - WIDE RANGE OF DATA RATES, MODULATIONS AND FEC CODE RATES
 - SIMULTANEOUS SUPPORT FOR SPREAD AND NON-SPREAD USERS
- **OPTIMIZED FOR USE WITH THE WGS SATELLITE**
 - TUNEABLE OVER 1.2 GHZ
 - 500 MHZ INSTANTANEOUS BANDWIDTH
 - MULTI-BAND/MULTI-BEAM OPERATION
 - MULTI-BEAM FAN IN/FAN OUT CAPABILITIES
 - GAIN STATES FOR OPTIMAL ASSIGNMENT OF DISADVANTAGED TERMINALS



Linkabit

Ruggedized MPM-1000 IP Modem

Network Capabilities

- Full Mesh, Hub-Spoke, and Hybrid Topologies Supported
- Burst-to-Burst Dynamic Control of Power, Spread Factors, Data Rates, Channel Rates, Modulation and Code Rates

Excellent Support for On The Move (OTM)

- Dynamic Spreading on a Burst-by-Burst Basis to Control Power Spectral Density
- Rapid Acquisition/Reacquisition
- Support of Doppler, Doppler-Rate, and Doppler Acceleration Requirements
- Link-Layer Assured Delivery (ARQ)

Optimized for Use with the WGS Satellite

- Multi-Band/Multi-Beam Operation Allows for Ka-Band and X-Band Terminals in Different Satellite Footprints to Operate in the Same Network
- WGS Gain States Allows for Optimal Assignment of Disadvantaged Terminals to Highest Gain State Segments
- Multi-Beam Fan-In and Fan-Out Channelization Allowing Control of a Network from a Single NC Along with Efficient Dissemination of Multi-Cast and Broadcast Traffic
- Full WGS RF Coverage, 1.2 GHz IF with an Instantaneous 500 MHz Bandwidth
- Non-Contiguous Bandwidth Segments can be Assigned Within One Transponder or Across Multiple Transponders

Ruggedized MPM-1000 IP Modem Technical Specifications

MF-TDMA Network Centric Waveform

Data Rate: 32 kbps – 4.096 Mbps (Per Carrier)

Turbo Coding: SCCC – Rates 1/2, 2/3 and 3/4

Interleaver Block Length: 640, 1280, 2560, and 5120

Modulation Formats: BPSK (Rate 1/2 Coding)
OQPSK (Rate 1/2, 2/3 and 3/4 Coding)
8 PSK (Rate 2/3 Coding)

Direct Sequence Spreading Gain:
0 to 12 dB (Spread Factor 1, 2, 4, 6, 8, 12, 16; up to 8.192 Mcps)

Number of Carriers (MF-TDMA Operation):
2 Tx
4 Rx

Encryption: AES-256 CBC TRANSEC
FIPS 140-2 Level 2 Certified

Control: SNMP V3/L-3 Linkabit HCI

Environmental

Conduction Cooled and Environmentally Sealed

Non-Operating Temp: -40°C to +71°C

Operating Temp: 0°C to +50°C

Vibration/Shock: MIL-STD-810F

EMI: MIL-STD-461

Mechanical/Electrical

Size: 1U 19" Rack Mountable Chassis
19" Wide x 1.75" High x 18.5" Deep

Weight: 19 lbs (excluding mounting slides)

Input Power: 90 VAC to 264 VAC, 47-63 Hz or
+24 VDC Vehicle Power (Optional)

Power Consumption: < 170 Watts

Frequency Reference: Internal or External (5 or 10 MHz)

Intermediate Frequency: Tx L-Band (950-2150 MHz) w/10 MHz Reference and Externally Supplied +18 to +48 VDC @ 3.0 Amps
Rx L-Band (950-2150 MHz) w/10 MHz Reference and +18 VDC @ 450 mA

Baseband Interfaces

Monitor/Control: 10/100/1000 Base-T
(NCW and FDMA Control)
RS-485 (FDMA Control)

NCW Data Port: 10/100/1000 Base-T

FDMA Data Port: MIL-STD-188-114/RS-422/RS-423

MIL-STD-188-165A (FDMA) Compliant

Type I: BPSK - 64 kbps to 6000 kbps
QPSK/OQPSK - 64 kbps to 8472 kbps
Convolutional Coding, RS Coding and Data Scrambling (IAW IESS-308, 309, 310 and OM-73)

Note: All specifications subject to change without notice.

Cleared by DoD/OSR for public release under OSR Case Number 11-S-0678 on January 4, 2011.



Linkabit

LINKABIT DIVISION
9890 TOWNE CENTRE DRIVE, SAN DIEGO, CA 92121 PHONE
(858) 552-9555 FAX (858) 552-9668 WWW.L-3COM.COM
PRODUCT SERVICE HELP DESK: 1-800-331-9401
e-mail: Linkabit Products @ L-3com .com

1078068000