

S2663 SAT-LOA-20050214-00038 IB2005000326
SkyTerra Communications, Inc.
SKYTERRA-1

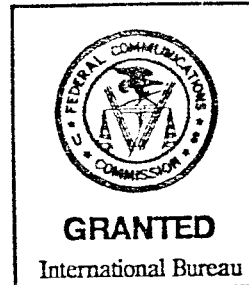

File # SAT-LOA-20050214-00038
with attached conditions

Call Sign S2663 Grant Date April 19, 2005
(or other identifier)

Term Dates Approved by OMB
From See Conditions To: See Conditions 3060-0678

Date & Time Filed: Feb 14 2005 6:59:00:000PM
File Number: SAT-LOA-20050214-00038
Callsign/Satellite ID: S2663

Approved: [Signature] Chief Satellite
Robert G. Nelson Engineering Branch

APPLICATION FOR SATELLITE SPACE STATION AUTHORIZATIONS FCC 312 MAIN FORM FOR OFFICIAL USE ONLY	FCC Use Only
---	--------------

APPLICANT INFORMATION

Enter a description of this application to identify it on the main menu:

SkyTerra-1

1-8. Legal Name of Applicant			
Name:	SkyTerra Communications, Inc.	Phone Number:	212-730-7524
DBA Name:		Fax Number:	
Street:	19 West 44th Street Suite 507	E-Mail:	
City:	New York	State:	NY
Country:	USA	Zipcode:	10036 -
Attention:	Robert Lewis		

Attachment
Conditions of Authorization
April 19, 2005

1. SkyTerra Communications, Inc.'s ("SkyTerra's") application, SAT-LOA-20050214-00038, Call Sign S2663, IS GRANTED. Accordingly, SkyTerra is authorized to launch and operate its SKYTERRA-1 Ka-band satellite at the 95.0° W.L. orbit location, in the 18.3-18.8 GHz (space-to-Earth), 19.7-20.2 GHz (space-to-Earth), 28.35-28.6 GHz (Earth-to-space) and 29.25-30.0 GHz (Earth-to-space) frequency bands in accordance with the terms, conditions, and technical specifications set forth in its application, this Attachment, and the Federal Communications Commission's ("Commission") Rules.
2. SKYTERRA-1 must be constructed, launched, and placed into operation in accordance with the technical parameters and terms and conditions of this authorization by these specified time periods following the date of authorization:
 - a. Execute a binding contract for construction by 4/19/2006
 - b. Complete the Critical Design Review by 4/19/2007
 - c. Commence construction by 4/19/2008
 - d. Launch and begin operations by 4/19/2010
 - e. SkyTerra must file a bond with the Commission in the amount of \$3 million, pursuant to the procedures set forth in Public Notice, DA 03-2602, 18 FCC Rcd 16283 (2003), as revised by Amendment of the Commission's Space Station Licensing Rules and Policies, *First Order on Reconsideration and Fifth Report and Order*, FCC 04-147 19 FCC Rcd. 12637 (2004), within 30 days of the date of this grant..

Failure to meet any of these dates shall render this authorization null and void.

3. SkyTerra's request for a waiver of 47 C.F.R. § 25.202(g) IS GRANTED as described herein. Requests to operate launch and transfer orbit TT&C for Ka-band networks outside of the authorized band are evaluated on a case-by-case basis until such time that the world wide network of TT&C facilities operational at Ka-band is in existence. Accordingly this grant is consistent with previous Commission actions.¹ SkyTerra may operate the TT&C for the SKYTERRA-1 satellite during launch and transfer orbit operations using 500 kHz of bandwidth at the center frequencies of 5926.5 MHz (Earth-to-space), 6424.5 MHz (Earth-to-space), 3701.0 MHz (space-to-Earth), 4199.0 MHz (space-to-Earth).
4. SkyTerra must cease operations of the TT&C for the SKYTERRA-1 satellite at 5926.5 MHz (Earth-to-space), 6424.5 MHz (Earth-to-space), 3701.0 MHz (space-to-Earth), and 4199.0 MHz (space-to-Earth) upon arrival at its assigned orbital location. Upon arrival at its assigned orbital location SkyTerra shall not operate the TT&C for SKYTERRA-1 on 5926.5 MHz (Earth-to-space), 6424.5 MHz (Earth-to-space), 3701.0 MHz (space-to-Earth), and 4199.0 MHz (space-to-Earth) without further Commission authorization.

¹ See, Echostar Satellite LLC., Modification of License to Select TT&C Frequencies for its Ka-band GSO Satellite at 117° W.L., *Order and Authorization*, DA 05-536, Adopted March 2, 2005.

5. SkyTerra shall coordinate its launch and transfer orbit TT&C operations with existing satellite networks to ensure that no unacceptable interference results from its TT&C operations during its launch and transfer orbit operations.
6. SkyTerra's launch and transfer orbit operations shall not cause harmful interference to any lawfully operating in-orbit satellites and SkyTerra shall cease operations immediately upon notification of such interference and SkyTerra shall inform the FCC in writing immediately of such an event.
7. SkyTerra is required to accept interference from other lawfully operating in-orbit satellites during its launch and transfer orbit operations.
8. SkyTerra's request for waiver of Section 47 C.F.R. § 25.210 (d) concerning the full frequency operation of the CONUS beam of the SKYTERRA-1 satellite IS DISMISSED AS MOOT. The request for waiver is unnecessary provided that SkyTerra operates both SKYTERRA-1 and SKYTERRA-2² satellites at the 95° W.L. orbital location. The collective operation of the CONUS beams on the two spacecraft with opposite polarizations result in full frequency reuse of the spectrum at 95° W. L. Should SkyTerra require operation of either SKYTERRA-1 or SKYTERRA-2 satellites at an orbital location other than 95° W.L. SkyTerra will be required to seek approval of the necessary waiver prior to operation.
9. SkyTerra shall prepare the necessary information, as may be required, for submission to the ITU to initiate and complete the advance publication, international coordination, due diligence, and notification process of this space station, in accordance with the ITU Radio Regulations. SkyTerra shall be held responsible for all cost recovery fees associated with these ITU filings. We also note that no protection from interference caused by radio stations authorized by other administrations is guaranteed unless coordination and notification procedures are timely completed or, with respect to individual administrations, by successfully completing coordination agreements. Any radio station authorization for which coordination has not been completed may be subject to additional terms and conditions as required to effect coordination of the frequency assignments of other administrations. *See* 47 C.F.R. § 25.111(b).
10. SkyTerra must coordinate its downlink operations for the specific frequencies authorized in the 18.3-18.8 GHz and 19.7-20.2 GHz frequency bands with U.S. Government systems, including Government operations to earth stations in foreign countries, in accordance with footnote US334 to the Table of Frequency Allocations, 47 C.F.R. § 2.106.
11. SkyTerra must conduct its operations pursuant to this authorization in a manner consistent with the power flux-density requirements of footnote US255 to the Table of Frequency Allocations, 47 C.F.R. § 2.106, 47 C.F.R. § 25.138(a)(6), and 47 C.F.R. § 25.208, of the Commission's Rules.
12. The license term for the SKYTERRA-1 satellite, Call Sign S2663, is fifteen years and will begin to run on the date that SkyTerra certifies to the Commission that the satellite has been successfully placed into orbit and its operation fully conforms to the terms and conditions of this authorization.

² *See* SkyTerra Communications, Inc. SAT-LOA-20050216-00040, *Grant Stamp* April XX, 2005

13. SkyTerra is afforded thirty days from the date of release of this grant and authorization to decline this authorization as conditioned. Failure to respond within this period will constitute formal acceptance of the authorization as conditioned.
14. This grant is issued pursuant to Section 0.261 of the Commission's rules on delegated authority, 47 C.F.R. § 0.261, and is effective upon release. Petitions for reconsideration under Section 1.106 or applications for review under Section 1.115 of the Commission's rules, 47 C.F.R. §§ 1.106, 1.115, may be filed within 30 days of the date of the public notice indicating that this action was taken.

9-16. Name of Contact Representative (If other than applicant)

Name:	Robert A. Mazer	Phone Number:	202-639-6755
Company:	Vinson & Elkins L.L.P.	Fax Number:	202-639-6604
Street:	1455 Pennsylvania Avenue, NW Suite 600	E-Mail:	rmazer@velaw.com
City:	Washington	State:	DC
Country:	USA	Zipcode:	20004 - 1008
Contact Title:		Relationship:	Legal Counsel

CLASSIFICATION OF FILING

17. Choose the button next to the classification that applies to this filing for both questions a. and b. Choose only one for 17a and only one for 17b.

a.

- (N/A) a1. Earth Station
 a2. Space Station

b.

- b1. Application for License of New Station
(N/A) b2. Application for Registration of New Domestic Receive-Only Station
(N/A) b3. Amendment to a Pending Application
(N/A) b4. Modification of License or Registration
(N/A) b5. Assignment of License or Registration
(N/A) b6. Transfer of Control of License or Registration
(N/A) b7. Notification of Minor Modification
(N/A) b8. Application for License of New Receive-Only Station Using Non-U.S. Licensed Satellite
- b9. Letter of Intent to Use Non-U.S. Licensed Satellite to Provide Service in the United States
 b10. Replacement Satellite Application - no new frequency bands
 b11. Replacement Satellite Application - new frequency bands (Not eligible for streamlined processing)
 b12. Petition for Declaratory Ruling to be Added to the Permitted List
(N/A) b13. Other (Please specify)

17c. Is a fee submitted with this application?
 If Yes, complete and attach FCC Form 159.
 If No, indicate reason for fee exemption (see 47 C.F.R. Section 1.1114).
 Governmental Entity Noncommercial educational licensee
 Other (please explain): Filing fee exempt pursuant to FCC Fee Code IB2004001900. See also FCC letter from Fern J. Jarmulnek, Deputy Chief, Satellite Division, to Robert Lewis, SkyTerra Communications, Inc. dated Feb. 14, 2005 (DA 05-418).

17c. Fee Classification BNY – Space Station (Geostationary)	Number of Satellite: 0
--	------------------------

18. If this filing is in reference to an existing station, enter:
 (a) Call sign of station:
 Not Applicable

19. If this filing is an amendment to a pending application enter:

(a) Date pending application was filed:	(b) File number of pending application:
Not Applicable	Not Applicable

TYPE OF SERVICE

<p>20. NATURE OF SERVICE: This filing is for an authorization to provide or use the following type(s) of service(s): Select all that apply:</p> <p><input checked="" type="checkbox"/> a. Fixed Satellite</p> <p><input type="checkbox"/> b. Mobile Satellite</p> <p><input type="checkbox"/> c. Radiodetermination Satellite</p> <p><input type="checkbox"/> d. Earth Exploration Satellite</p> <p><input type="checkbox"/> e. Direct to Home Fixed Satellite</p> <p><input type="checkbox"/> f. Digital Audio Radio Service</p> <p><input type="checkbox"/> g. Other (please specify)</p>	
<p>21. STATUS: Choose the button next to the applicable status. Choose only one.</p> <p><input type="radio"/> Common Carrier <input checked="" type="radio"/> Non-Common Carrier</p>	<p>22. If earth station applicant, check all that apply.</p> <p>Not Applicable</p>
<p>23. If applicant is providing INTERNATIONAL COMMON CARRIER service, see instructions regarding Sec. 214 filings. Choose one. Are these facilities:</p> <p><input type="radio"/> Connected to a Public Switched Network <input type="radio"/> Not connected to a Public Switched Network <input checked="" type="radio"/> N/A</p>	
<p>24. FREQUENCY BAND(S): Place an "X" in the box(es) next to all applicable frequency band(s).</p> <p><input type="checkbox"/> a. C-Band (4/6 GHz) <input type="checkbox"/> b. Ku-Band (12/14 GHz)</p> <p><input checked="" type="checkbox"/> c. Other (Please specify upper and lower frequencies in MHz.)</p> <p>Frequency Lower: 18300 Frequency Upper: 30000 (Please specify additional frequencies in an attachment)</p>	

TYPE OF STATION

25. CLASS OF STATION: Choose the button next to the class of station that applies. Choose only one.

- (N/A) a. Fixed Earth Station
- (N/A) b. Temporary-Fixed Earth Station
- (N/A) c. 12/14 GHz VSAT Network
- (N/A) d. Mobile Earth Station
- e. Geostationary Space Station.
- f. Non-Geostationary Space Station
- g. Other (please specify)

26. TYPE OF EARTH STATION FACILITY: Not Applicable

PURPOSE OF MODIFICATION

27. The purpose of this proposed modification is to: (Place an "X" in the box(es) next to all that apply.) Not Applicable

ENVIRONMENTAL POLICY

28. Would a Commission grant of any proposal in this application or amendment have a significant environmental impact as defined by 47 CFR 1.1307? If YES, submit the statement as required by Sections 1.1308 and 1.1311 of the Commission's rules, 47 C.F.R. §§ 1.1308 and 1.1311, as an exhibit to this application. A Radiation Hazard Study must accompany all applications for new transmitting facilities, major modifications, or major amendments. Yes No

ALIEN OWNERSHIP

Earth station applicants not proposing to provide broadcast, common carrier, aeronautical en route or aeronautical fixed radio station services are not required to respond to Items 30-34.

29. Is the applicant a foreign government or the representative of any foreign government?

Yes No N/A

30. Is the applicant an alien or the representative of an alien?

Yes No N/A

31. Is the applicant a corporation organized under the laws of any foreign government?

Yes No N/A

32. Is the applicant a corporation of which more than one-fifth of the capital stock is owned of record or voted by aliens or their representatives or by a foreign government or representative thereof or by any corporation organized under the laws of a foreign country?

Yes No N/A

33. Is the applicant a corporation directly or indirectly controlled by any other corporation of which more than one-fourth of the capital stock is owned of record or voted by aliens, their representatives, or by a foreign government or representative thereof or by any corporation organized under the laws of a foreign country?

Yes No N/A

34. If any answer to questions 29, 30, 31, 32 and/or 33 is Yes, attach as an exhibit an identification of the aliens or foreign entities, their nationality, their relationship to the applicant, and the percentage of stock they own or vote.

BASIC QUALIFICATIONS

<p>35. Does the Applicant request any waivers or exemptions from any of the Commission's Rules? If Yes, attach as an exhibit, copies of the requests for waivers or exceptions with supporting documents.</p>	<p><input checked="" type="radio"/> Yes <input type="radio"/> No</p>
<p>36. Has the applicant or any party to this application or amendment had any FCC station authorization or license revoked or had any application for an initial, modification or renewal of FCC station authorization, license, or construction permit denied by the Commission? If Yes, attach as an exhibit, an explanation of circumstances.</p>	<p><input type="radio"/> Yes <input checked="" type="radio"/> No</p>
<p>37. Has the applicant, or any party to this application or amendment, or any party directly or indirectly controlling the applicant ever been convicted of a felony by any state or federal court? If Yes, attach as an exhibit, an explanation of circumstances.</p>	<p><input type="radio"/> Yes <input checked="" type="radio"/> No</p>
<p>38. Has any court finally adjudged the applicant, or any person directly or indirectly controlling the applicant, guilty of unlawfully monopolizing or attemptiing unlawfully to monopolize radio communication, directly or indirectly, through control of manufacture or sale of radio apparatus, exclusive traffic arrangement or any other means or unfair methods of competition? If Yes, attach as an exhibit, an explanation of circumstances</p>	<p><input type="radio"/> Yes <input checked="" type="radio"/> No</p>
<p>39. Is the applicant, or any person directly or indirectly controlling the applicant, currently a party in any pending matter referred to in the preceding two items? If yes, attach as an exhibit, an explanation of the circumstances.</p>	<p><input type="radio"/> Yes <input checked="" type="radio"/> No</p>

40. If the applicant is a corporation and is applying for a space station license, attach as an exhibit the names, address, and citizenship of those stockholders owning a record and/or voting 10 percent or more of the Filer's voting stock and the percentages so held. In the case of fiduciary control, indicate the beneficiary(ies) or class of beneficiaries. Also list the names and addresses of the officers and directors of the Filer. Response

41. By checking Yes, the undersigned certifies, that neither applicant nor any other party to the application is subject to a denial of Federal benefits that includes FCC benefits pursuant to Section 5301 of the Anti-Drug Act of 1988, 21 U.S.C. Section 862, because of a conviction for possession or distribution of a controlled substance. See 47 CFR 1.2002(b) for the meaning of "party to the application" for these purposes. Yes No

42a. Does the applicant intend to use a non-U.S. licensed satellite to provide service in the United States? If Yes, answer 42b and attach an exhibit providing the information specified in 47 C.F.R. 25.137, as appropriate. If No, proceed to question 43. Yes No

42b. What administration has licensed or is in the process of licensing the space station? If no license will be issued, what administration has coordinated or is in the process of coordinating the space station?

43. Description. (Summarize the nature of the application and the services to be provided). (If the complete description does not appear in this box, please go to the end of the form to view it in its entirety.)

See attached application Pleading which includes a response to Question 35.

Application Pleading

CERTIFICATION

The Applicant waives any claim to the use of any particular frequency or of the electromagnetic spectrum as against the regulatory power of the United States because of the previous use of the same, whether by license or otherwise, and requests an authorization in accordance with this application. The applicant certifies that grant of this application would not cause the applicant to be in violation of the spectrum aggregation limit in 47 CFR Part 20. All statements made in exhibits are a material part hereof and are incorporated herein as if set out in full in this application. The undersigned, individually and for the applicant, hereby certifies that all statements made in this application and in all attached exhibits are true, complete and correct to the best of his or her knowledge and belief, and are made in good faith.

44. Applicant is a (an): (Choose the button next to applicable response.)

- Individual
- Unincorporated Association
- Partnership
- Corporation
- Governmental Entity
- Other (please specify)

45. Name of Person Signing
Jeffrey A. Leddy

46. Title of Person Signing
President and CEO

47. Please supply any need attachments.

1: Technical Attachment

2:

3:

WILLFUL FALSE STATEMENTS MADE ON THIS FORM ARE PUNISHABLE BY FINE AND / OR IMPRISONMENT
(U.S. Code, Title 18, Section 1001), AND/OR REVOCATION OF ANY STATION AUTHORIZATION
(U.S. Code, Title 47, Section 312(a)(1)), AND/OR FORFEITURE (U.S. Code, Title 47, Section 503).

Completed Schedule S

FCC NOTICE REQUIRED BY THE PAPERWORK REDUCTION ACT

The public reporting for this collection of information is estimated to average 2 hours per response, including the time for reviewing instructions, searching existing data sources, gathering and maintaining the required data, and completing and reviewing the collection of information. If you have any comments on this burden estimate, or how we can improve the collection and reduce the burden it causes you, please write to the Federal Communications Commission, AMD-PERM, Paperwork Reduction Project (3060-0678), Washington, DC 20554. We will also accept your comments regarding the Paperwork Reduction Act aspects of this collection via the Internet if you send them to jboley@fcc.gov. PLEASE DO NOT SEND COMPLETED FORMS TO THIS ADDRESS.

Remember – You are not required to respond to a collection of information sponsored by the Federal government, and the government may not conduct or sponsor this collection, unless it displays a currently valid OMB control number or if we fail to provide you with this notice. This collection has been assigned an OMB control number of 3060-0678.

THE FOREGOING NOTICE IS REQUIRED BY THE PAPERWORK REDUCTION ACT OF 1995, PUBLIC LAW 104-13, OCTOBER 1, 1995, 44 U.S.C. SECTION 3507.

**Before the
FEDERAL COMMUNICATIONS COMMISSION
Washington, D.C. 20554**

In the Matter of)	
)	
SKYTERRA COMMUNICATIONS, INC.)	
)	File No. _____
Application for Authority to Construct, Launch)	
and Operate Two Collocated Geostationary)	
Satellites in the Fixed-Satellite Service Using the)	
Ka-Band at the 95° W.L. Orbital Location)	

APPLICATION

Pursuant to Sections 308, 309 and 319 of the Communications Act of 1934, as amended, 47 U.S.C. §§ 308, 309, 319, Part 25 of the Commission's rules, 47 C.F.R. Part 25, and the Commission's May 19, 2003 *First-Come-First-Served Report and Order ("FCFS Order")*,¹ SkyTerra Communications, Inc. ("SkyTerra") hereby files application for authority to construct, launch and operate two geostationary orbit ("GSO") satellites in the Fixed-Satellite Service ("FSS") using the Ka-band frequencies. SkyTerra requests authority to use these frequency bands at the 95° W.L. orbital slot. In accordance with the *FCFS Order*, this pending application will not cause SkyTerra to exceed the five-satellite limit for licensed-but-unbuilt and pending applications in each of these frequency bands.²

Specifically, SkyTerra requests authority to launch and operate two GSO FSS satellites "SkyTerra 1 and SkyTerra 2" collocated at 95° W.L. that would operate in the portion of the Ka-

¹ *In the Matter of Amendment of the Commission's Space Licensing Rules and Policies*, IB Docket No. 02-34, First Report and Order and Further Notice of Proposed Rulemaking, 18 FCC Rcd 10760 (2003) ("*FCFS Order*").

² *See id.* at 10847-48, ¶¶ 230-31.

band designated for primary GSO FSS use³ — i.e., 18.3-18.8 GHz and 19.7-20.2 GHz from space to earth,⁴ 28.35-28.6 GHz and 29.25-30.0 GHz from earth to space.⁵ Pursuant to the Commission's directions, SkyTerra is submitting a separate filing fee, application and Schedule S for each satellite.

SkyTerra is an emerging provider of Direct-to-Home ("DTH") services in the multichannel video programming distribution ("MVPD") and broadband access markets. The proposed satellites will support SkyTerra's MVPD offerings and will allow the company to provide various kinds of multichannel video and two-way broadband services, which will help it to compete in the MVPD marketplace.

The instant application satisfies the requirements of first-come-first-served processing under the *FCFS Order*, and SkyTerra requests that it be placed in the appropriate position in the first-come, first-served queue based on its filing date and time.

I. GENERAL DESCRIPTION OF SKYTERRA FSS SATELLITE SYSTEM AND OPERATIONS

The proposed SkyTerra satellite system will consist of two satellites, SkyTerra-1 and SkyTerra-2, collocated and operating from the 95° W.L. orbital location. Both satellites will incorporate a multi-beam payload architecture that provides three distinct coverage patterns

³ Section 25.114(a) of the Commission's Rules states that each proposed space station must be submitted on FCC Form 312, 47 C.F.R. § 25.114(a).

⁴ See *In the Matter of Redesignation of the 17.7-19.7 GHz Frequency Band, Blanket Licensing of Satellite Earth Stations in the 17.7-20.2 GHz and 27.5-30.0 GHz Frequency Bands, and the Allocation of Additional Spectrum in the 17.3-17.8 GHz and 24.75-25.25 GHz Frequency Bands for Broadcast Satellite-Service Use*, IB Docket No. 98-172, Report and Order, 15 FCC Rcd 13430, 13433-44, ¶¶ 28-29 (2000).

⁵ See *In the Matter of Rulemaking to Amend Parts 1, 2, 21, and 25 of the Commission's Rules to Redesignate the 27.5-29.5 GHz Frequency Band, to Reallocate the 29.5-30.0 GHz Frequency Band, to Establish Rules and Policies for Local Multipoint Distribution Service and for Fixed Satellite Services*, CC Docket No. 92-297, Third Report and Order, 12 FCC Rcd 22310, 22326-27, ¶¶ 40-41 (1997).

across the continental United States (“CONUS”), including full CONUS coverage, regional coverage using multiple contiguous spot beams and market-specific spot beams for targeted service delivery. The proposed space system will utilize the GSO portion of the Ka-band spectrum in each direction, including the 18.3-18.8 GHz and 19.7-20.2 GHz bands from space-to-earth and the 28.35-28.6 GHz and 29.25-30 GHz bands from earth-to-space.

Each satellite will have four CONUS transponder consisting of 46.25 MHz using 185 MHz of the assigned Ka-band spectrum in the forward direction only. The two CONUS beams will utilize right- and left-hand (“RHCP/LHCP”) circular polarization respectively to provide two overlapping CONUS beams across the service area.

The two satellites’ combined payload will also include 32 contiguous regional beams that provide service to specific regional areas throughout the service area in both the forward and return paths. The regional transponders will employ a four-times frequency re-use pattern and dual polarization plan (RHCP/LHCP). In the forward path, the 32 regional forward transponders will use 60 MHz of the assigned Ka-band spectrum, with each transponder consisting of one 54 MHz channel. In the return path, the 32 regional return transponders will utilize 42 MHz of the assigned Ka-band spectrum with each regional return transponder consisting of 42 286 kbps channels.

In addition, each satellite payload will include 21 spot beams used to provide services to high-density population areas throughout the national service area. When collocated in orbit, the two satellites’ combined payload will include 42 market-specific spot beams operating in both the forward and return paths. The spot transponders will employ a four-times frequency re-use pattern and dual polarization plan (RHCP/LHCP). In the forward path, the 42 spot forward transponders will use 292 MHz of the assigned Ka-band spectrum with each Spot Forward

transponder consisting of eight 36.5 MHz channels. In the return path, the 42 spot return transponders will utilize 85 MHz of the assigned Ka-band spectrum with each spot return transponder consisting of thirty-one 3.12 Mbps channels.

Schedule S hereto contains a detailed description of the technical specifications of the proposed satellites at the 95° W.L. orbital location and is incorporated into this narrative by reference.

II. SERVICES TO BE PROVIDED

SkyTerra plans to offer the following services to customers using the satellite system proposed in this application:

- Direct-to-home video and audio services, including extensive local-into-local services, high definition programming, on-demand entertainment, digital music, and interactive media.
- Two-way narrowband and broadband services, including interactive television and high-speed Internet access. This will allow SkyTerra compete more effectively with its primary competitors (DBS and cable operators), which increasingly bundle their traditional multichannel video services with interactive offerings and high-speed Internet access.
- Transport of programming to SkyTerra uplink centers and remote gateways.

III. FINANCIAL QUALIFICATIONS; COST OF CONSTRUCTION, LAUNCH AND OPERATION

The *FCFS Order* abolished the requirement of submitting an estimate of the proposed system's cost, as well as the financial qualification requirements.⁶ Nonetheless, SkyTerra is amply qualified to finance the construction, launch and operation of the proposed satellites.

⁶ *FCFS Order*, 18 FCC Rcd at 10824, ¶ 164, App. B §§ 6 and 13 (deleting Sections 25.114(c)(13), 25.140(b)(3)-(4) and 25.140(c)-(d) of the Commission's Rules).

IV. LEGAL QUALIFICATIONS

SkyTerra's legal qualifications are set forth in the Form 312 submitted today with this application.

V. MILESTONES

SkyTerra will submit itself to the milestones contemplated by the Commission's new rules for satellite licensees as set forth in the *FCFS Order*.⁷

VI. PUBLIC INTEREST CONSIDERATIONS

The grant of this application clearly serves the public interest by allowing the provision of competitive direct-to-home services (including local-into-local and high definition channels), two-way broadband, and interactive television services to consumers located throughout the continental United States. Granting of this application will have a three-fold public benefit:

First, it will provide consumers with "greater choice" in their selection of entertainment and information services. By using the proposed satellites to deliver a competitive multichannel video offering, SkyTerra can provide these consumers with an alternative to incumbent DBS and cable offerings.

Second, the grant of this application will provide SkyTerra with the necessary capacity to effectively compete with established DBS and cable operators and to provide consumers with a comprehensive service offering that is competitive in both price and service.

Third, the proposed system will enable SkyTerra to expand the number of markets where local-into-local is currently offered via satellite and to support local broadcasters across the country as they transition to digital operations.

⁷ See *id.* at 10827-88, ¶ 174 (contract execution within one year; critical design review within two years; commence construction within three years; and launch and operate within five years).

VII. THE APPLICATION SATISFIES THE REQUIREMENTS FOR FCFS PROCESSING

The Commission's *FCFS Order* explicitly provides that the Commission will consider applications under FCFS processing so long as the ITU has adopted a frequency allocation for the proposed service, even if the Commission has not yet adopted a domestic allocation.⁸ This application submitted by SkyTerra satisfies this requirement because all of the frequency bands being requested in the proposed application have primary FSS allocations, both domestically and internationally.

VIII. WAIVER REQUESTS

SkyTerra hereby requests all necessary waivers of Section 25.202(g) of the Commission's Rules in order to allow it to operate using the center frequency 5926.5 MHz and 6424 MHz (uplink), and 3701 MHz and 4199 MHz (downlink) frequency bands, each of 500 KHz bandwidth which are outside of its authorized Ka-band frequencies, to perform telemetry, tracking and control ("TT&C") functions for launch and transfer orbit operations. There is good cause for this requested waiver.

First, SkyTerra is requesting the use of these frequencies on a "one time only" interim basis to support mission-critical launch and transfer orbit operations. Upon successful launch and completion of transfer orbit operations, SkyTerra will use its authorized Ka-band frequencies to perform in-flight TT&C functions and cease to use the requested frequencies.

Second, due to the limited availability of Ka-band TT&C facilities in the world and the critical importance of the deployment stage, the use of these flight-proven frequencies for launch

⁸ *Id.* at 10809, ¶ 124 ("We will ... consider applications filed after the ITU adopts an international frequency allocation but before the Commission adopts a domestic allocation.")

and transfer orbit operations will help SkyTerra to further reduce risk to the program and to help ensure a successful launch and transfer orbit operations.

Third, although the CONUS beam transmits in both RHC and LHC polarizations, it does not do so on the same frequency. Therefore the SkyTerra-1 satellite's CONUS beam does not meet the requirements for full frequency re-use of the spectrum as required by Section 25.210(d) of the Commission's Rules. However, the SkyTerra-2 satellite's CONUS beam transmits on the same frequencies and in the opposite polarizations of the SkyTerra-1 satellite's CONUS beam. When the two satellites are co-located, the collective satellite system does provide full frequency re-use of the spectrum at the 95°W.L. location. SkyTerra requests a waiver of Section 25.210(d) for the SkyTerra-1 satellite's CONUS beam to the extent it is necessary.

IX. COMPLIANCE WITH COMMISSION RULES

The proposed satellites are compatible with two-degree spacing rules in all non-allocated bands and will not cause harmful interference to any authorized user of the spectrum. They also comply with all technical and non-technical requirements of Part 25 of the Rules as amended by the *FCFS Order*. Specifically, SkyTerra will comply with all applicable power flux density limits⁹ and with the Commission's full frequency reuse requirements.¹⁰ Except where any waivers have been requested, SkyTerra commits to comply with the Commission's Rules for GSO FSS satellites operating in the Ka-bands.¹¹

⁹ See 47 C.F.R. §§ 25.208(c)-(d) (GSO FSS downlink Ka-band frequencies).

¹⁰ See 47 C.F.R §§ 25.210(g).

¹¹ See 47 C.F.R § 25.145.

X. ORBITAL DEBRIS MITIGATION

Pursuant to Section 2.217(d) of the Commission's Rules,¹² applicants requesting a satellite authorization must submit a narrative statement describing the debris mitigation design and operational strategies, if any, that they will use.

Details of our debris mitigation program are contained in Attachment A hereto.

XI. ITU COST RECOVERY

SkyTerra is aware that as a result of the actions taken at the 1998 Plenipotentiary Conference, as modified by the ITU Council in June 2001, processing fees will now be charged by the ITU for satellite network filings. As a consequence, Commission applicants are responsible for any and all fees charged by the ITU. SkyTerra is aware of and unconditionally accepts this requirement and its responsibility to pay any ITU cost recovery fees for the ITU filings associated with this application. Invoices for such fees may be sent to the contact representative listed on the accompanying Form 312.

¹² 47 C.F.R. § 2.217(d).

XII. CONCLUSION

For the foregoing reasons, SkyTerra respectfully requests that the Commission promptly approve this application as in the public interest, convenience and necessity.

Respectfully submitted,

SKYTERRA COMMUNICATIONS, INC.

By: s/ Jeffrey A. Leddy

Jeffrey A. Leddy
President and CEO
SkyTerra Communications, Inc.
6340 Sugarloaf Parkway
Suite 200
Duluth, Georgia 30097
(678) 775-6717

February 14, 2005
Robert A. Mazer
R. Edward Price
Vinson & Elkins L.L.P.
1455 Pennsylvania Avenue, N.W.
Washington, D.C. 20004-1008
(202) 639-6500

Its Attorneys

Response to Question 40

Ten Percent or Greater Shareholders

Name	Address	Citizenship	Percentage of Equity
Apollo Management IV, L.P.*	1999 Avenue of the Stars Suite 1900 Los Angeles, CA 90067	USA	100%

*The general partner of Apollo Management IV, L.P. is Apollo Advisors IV, L.P. (same address and citizenship as above). The general partner of Apollo Advisors IV, L.P. is Apollo Capital Management IV, Inc. (same address and citizenship as above).

Officers and Directors

Name	Title	Address
Jeffrey A. Leddy	President and CEO	19 West 44th Street Suite 507 New York, NY 10036
Robert C. Lewis	Senior Vice President, General Counsel and Secretary	19 West 44th Street Suite 507 New York, NY 10036
Erik J. Goldman	Vice President	19 West 44th Street Suite 507 New York, NY 10036
Keith C. Kammer	Vice President	19 West 44th Street Suite 507 New York, NY 10036
Craig J. Kaufmann	Controller and Treasurer	19 West 44th Street Suite 507 New York, NY 10036
Jeffrey M. Killeen	Director	19 West 44th Street Suite 507 New York, NY 10036
William F. Stasior	Director	19 West 44th Street Suite 507 New York, NY 10036

Name	Title	Address
Andrew D. Africk	Director	19 West 44th Street Suite 507 New York, NY 10036
Michael S. Gross	Director	19 West 44th Street Suite 507 New York, NY 10036
Marc J. Rowan	Director	19 West 44th Street Suite 507 New York, NY 10036

ATTACHMENT A

SKYTERRA COMMUNICATIONS, INC.

SKYTERRA-1 SATELLITE TECHNICAL DESCRIPTION

A.1 GENERAL DESCRIPTION

SkyTerra Communications, Inc. (“SkyTerra”) is seeking authority to operate two co-located satellites (SkyTerra-1 and SkyTerra-2) at the 95°W.L. orbital location to provide Ka-band domestic Fixed Satellite Services (“FSS”) to the continental United States (“CONUS”).

Although there are two distinct satellites, they collectively operate as one overall integrated system. This technical attachment describes the SkyTerra-1 satellite system. The satellite will use the 18.3-18.8 GHz and 19.7-20.2 GHz frequencies for space-to-Earth transmissions and the 28.35-28.6 GHz and 29.25-30.0 GHz frequencies for Earth-to-space transmissions.

The SkyTerra-1 satellite will provide approximately 9.8 times frequency re-use across the 1,000 MHz of spectrum through the utilization of a combination of spatial isolation and dual circular polarizations. The satellite will use multiple spot beams and a CONUS beam to provide narrowband and broadband two-way services to small user terminals.

A.2 ORBITAL LOCATION

SkyTerra requests Commission authority to use the 95° W.L. geostationary orbital location for the SkyTerra-1 satellite. This available orbital location has been selected because, among other things, it provides high elevation angles to all of CONUS, which is very important for satellite services to large numbers of small and inexpensive consumer earth stations. The high elevation minimizes the risk of signal blockage due to buildings and foliage, and also minimizes the atmospheric and rain attenuation, a very important consideration for the Ka-band frequencies.

Table A.2-1 Elevation Angles for Various Cities Relative to the 95°W.L. Orbital Location

City	Elevation Angle Relative to 95°W.L	City	Elevation Angle Relative to 95°W.L
Portland, ME	33.9°	Dallas, TX	43.3
Boston, MA	35.4°	Salt Lake City, UT	39.7°
New York, NY	38.2°	Seattle, WA	29.4°
Washington, DC	41.2°	Portland, OR	30.9°
Miami, FL	55.6°	San Francisco, CA	37.8°
Atlanta, GA	49.3°	Los Angeles, CA	43.3°
Chicago, IL	41.0°	Honolulu, HI	16.8°
Denver, CO	42.9°	Anchorage, AK	7.4°

Table A.2-1 shows that the elevation angles between the 95° W.L. geostationary orbital location and the majority of cities are above a 30° elevation angle. The only parts of the service area that are below 30° are parts of the West Coast and North West CONUS (where the elevation angle is still greater than 29°). However, both Alaska and Hawaii are located too far west of the SkyTerra-1 satellite to be effectively served, with the elevation angle towards Hawaii being approximately 16° and toward Alaska in the range 0° to 8°. These low elevation angles are particularly problematic at Ka-band frequencies because of the increased atmospheric and rain attenuation. For these reasons, Alaska and Hawaii will not be served from this orbital location.

A.3 SATELLITE COVERAGE

The SkyTerra-1 satellite will provide broadcast and two-way connectivity services to small consumer terminals located throughout CONUS. The Ka-band beam coverage consists of three different beam types: very small Spot beams used in both the uplink and downlink, Regional beams used in both the uplink and downlink and a CONUS-wide downlink beam. Additional information on the satellite's various beams used to provide the satellite coverage can be found in Sections A.5 and A.6 below.

A.4 FREQUENCY AND POLARIZATION PLANS

The frequency, polarization and beam connectivity scheme for the SkyTerra-1 satellite's communications transponders is provided in Table A.4-1. The Table also provides a description of the path for each transponder and indicates whether the particular path shares the TWTA with other paths. Figure A.7-1 illustrates the five path-types used by the network. Because two or three paths can share the same TWTA, the traditional definition of a transponder is somewhat skewed and this has consequences with respect to certain information to be provided in Schedule S. This will be elaborated upon later in this attachment.

Table A.4-1. SkyTerra-1 Frequency, Polarization and Beam Connectivity Plan

TXP #	BW (MHz)	Path Description	UPLINK			DOWNLINK			
			Beam	POL	F _c	Beam	POL	F _c	TWTA Shared?
1	85	Spot Return	Spot 2	RHCP	29872.50	Spot 2	LHCP	18522.50	Yes
2	85	Spot Return	Spot 3	RHCP	29872.50	Spot 3	LHCP	18522.50	Yes
3	85	Spot Return	Spot 5	RHCP	29872.50	Spot 5	LHCP	18522.50	Yes
4	85	Spot Return	Spot 6	RHCP	29872.50	Spot 6	LHCP	18522.50	Yes
5	85	Spot Return	Spot 10	RHCP	29872.50	Spot 10	LHCP	18522.50	Yes
6	85	Spot Return	Spot 11	RHCP	29872.50	Spot 11	LHCP	18522.50	Yes
7	85	Spot Return	Spot 13	RHCP	29872.50	Spot 13	LHCP	18522.50	Yes
8	85	Spot Return	Spot 14	RHCP	29872.50	Spot 14	LHCP	18522.50	Yes
9	85	Spot Return	Spot 16	RHCP	29872.50	Spot 16	LHCP	18522.50	Yes
10	85	Spot Return	Spot 18	RHCP	29872.50	Spot 18	LHCP	18522.50	Yes
11	85	Spot Return	Spot 19	RHCP	29872.50	Spot 19	LHCP	18522.50	Yes
12	85	Spot Return	Spot 21	RHCP	29872.50	Spot 21	LHCP	18522.50	Yes
13	85	Spot Return	Spot 22	RHCP	29872.50	Spot 22	LHCP	18522.50	Yes
14	85	Spot Return	Spot 23	RHCP	29872.50	Spot 23	LHCP	18522.50	Yes
15	85	Spot Return	Spot 25	RHCP	29872.50	Spot 25	LHCP	18522.50	Yes
16	85	Spot Return	Spot 27	RHCP	29872.50	Spot 27	LHCP	18522.50	Yes
17	85	Spot Return	Spot 31	RHCP	29872.50	Spot 31	LHCP	18522.50	Yes
18	85	Spot Return	Spot 34	RHCP	29872.50	Spot 34	LHCP	18522.50	Yes
19	85	Spot Return	Spot 35	RHCP	29872.50	Spot 35	LHCP	18522.50	Yes
20	85	Spot Return	Spot 36	RHCP	29872.50	Spot 36	LHCP	18522.50	Yes
21	85	Spot Return	Spot 41	RHCP	29872.50	Spot 41	LHCP	18522.50	Yes
22	10.5	Regional Return	R10	LHCP	29795.00	Spot 2	LHCP	18445.00	Yes
23	10.5	Regional Return	R18	LHCP	29795.00	Spot 3	LHCP	18445.00	Yes
24	10.5	Regional Return	R16	LHCP	29795.00	Spot 5	LHCP	18445.00	Yes
25	10.5	Regional Return	R9	LHCP	29795.00	Spot 6	LHCP	18445.00	Yes
26	10.5	Regional Return	R29	LHCP	29795.00	Spot 10	LHCP	18445.00	Yes
27	10.5	Regional Return	R5	LHCP	29795.00	Spot 13	LHCP	18445.00	Yes
28	10.5	Regional Return	R7	LHCP	29795.00	Spot 14	LHCP	18445.00	Yes
29	10.5	Regional Return	R3	LHCP	29795.00	Spot 16	LHCP	18445.00	Yes
30	10.5	Regional Return	R20	LHCP	29795.00	Spot 18	LHCP	18445.00	Yes
31	10.5	Regional Return	R31	LHCP	29795.00	Spot 19	LHCP	18445.00	Yes
32	10.5	Regional Return	R14	LHCP	29795.00	Spot 21	LHCP	18445.00	Yes
33	10.5	Regional Return	R1	LHCP	29795.00	Spot 22	LHCP	18445.00	Yes
34	10.5	Regional Return	R12	LHCP	29795.00	Spot 25	LHCP	18445.00	Yes
35	10.5	Regional Return	R22	LHCP	29795.00	Spot 27	LHCP	18445.00	Yes
36	10.5	Regional Return	R26	LHCP	29795.00	Spot 34	LHCP	18445.00	Yes
37	10.5	Regional Return	R27	LHCP	29795.00	Spot 35	LHCP	18445.00	Yes
38	10.5	Regional Return	R24	LHCP	29795.00	Spot 41	LHCP	18445.00	Yes
39	10.5	Regional Return	R10	LHCP	29774.00	Spot 2	LHCP	18424.00	Yes
40	10.5	Regional Return	R18	LHCP	29774.00	Spot 3	LHCP	18424.00	Yes
41	10.5	Regional Return	R16	LHCP	29774.00	Spot 5	LHCP	18424.00	Yes
42	10.5	Regional Return	R9	LHCP	29774.00	Spot 6	LHCP	18424.00	Yes
43	10.5	Regional Return	R29	LHCP	29774.00	Spot 10	LHCP	18424.00	Yes
44	10.5	Regional Return	R5	LHCP	29774.00	Spot 13	LHCP	18424.00	Yes
45	10.5	Regional Return	R7	LHCP	29774.00	Spot 14	LHCP	18424.00	Yes
46	10.5	Regional Return	R3	LHCP	29774.00	Spot 16	LHCP	18424.00	Yes
47	10.5	Regional Return	R20	LHCP	29774.00	Spot 18	LHCP	18424.00	Yes
48	10.5	Regional Return	R31	LHCP	29774.00	Spot 19	LHCP	18424.00	Yes
49	10.5	Regional Return	R14	LHCP	29774.00	Spot 21	LHCP	18424.00	Yes
50	10.5	Regional Return	R1	LHCP	29774.00	Spot 22	LHCP	18424.00	Yes
51	10.5	Regional Return	R12	LHCP	29774.00	Spot 25	LHCP	18424.00	Yes
52	10.5	Regional Return	R22	LHCP	29774.00	Spot 27	LHCP	18424.00	Yes
53	10.5	Regional Return	R26	LHCP	29774.00	Spot 34	LHCP	18424.00	Yes
54	10.5	Regional Return	R27	LHCP	29774.00	Spot 35	LHCP	18424.00	Yes
55	10.5	Regional Return	R24	LHCP	29774.00	Spot 41	LHCP	18424.00	Yes

Table A.4-1 cont). SkyTerra-1 Frequency, Polarization and Beam Connectivity Plan

TXP #	BW (MHz)	Path Description	UPLINK			DOWNLINK			TWTA Shared?
			Beam	POL	F _c	Beam	POL	F _c	
56	10.5	Regional Return	R10	LHCP	29754.00	Spot 2	LHCP	18404.00	Yes
57	10.5	Regional Return	R18	LHCP	29754.00	Spot 3	LHCP	18404.00	Yes
58	10.5	Regional Return	R16	LHCP	29754.00	Spot 5	LHCP	18404.00	Yes
59	10.5	Regional Return	R9	LHCP	29754.00	Spot 6	LHCP	18404.00	Yes
60	10.5	Regional Return	R29	LHCP	29754.00	Spot 10	LHCP	18404.00	Yes
61	10.5	Regional Return	R5	LHCP	29754.00	Spot 13	LHCP	18404.00	Yes
62	10.5	Regional Return	R7	LHCP	29754.00	Spot 14	LHCP	18404.00	Yes
63	10.5	Regional Return	R3	LHCP	29754.00	Spot 16	LHCP	18404.00	Yes
64	10.5	Regional Return	R20	LHCP	29754.00	Spot 18	LHCP	18404.00	Yes
65	10.5	Regional Return	R31	LHCP	29754.00	Spot 19	LHCP	18404.00	Yes
66	10.5	Regional Return	R14	LHCP	29754.00	Spot 21	LHCP	18404.00	Yes
67	10.5	Regional Return	R1	LHCP	29754.00	Spot 22	LHCP	18404.00	Yes
68	10.5	Regional Return	R12	LHCP	29754.00	Spot 25	LHCP	18404.00	Yes
69	10.5	Regional Return	R22	LHCP	29754.00	Spot 27	LHCP	18404.00	Yes
70	10.5	Regional Return	R26	LHCP	29754.00	Spot 34	LHCP	18404.00	Yes
71	10.5	Regional Return	R27	LHCP	29754.00	Spot 35	LHCP	18404.00	Yes
72	10.5	Regional Return	R24	LHCP	29754.00	Spot 41	LHCP	18404.00	Yes
73	10.5	Regional Return	R10	LHCP	29733.00	Spot 2	LHCP	18383.00	Yes
74	10.5	Regional Return	R18	LHCP	29733.00	Spot 3	LHCP	18383.00	Yes
75	10.5	Regional Return	R16	LHCP	29733.00	Spot 5	LHCP	18383.00	Yes
76	10.5	Regional Return	R9	LHCP	29733.00	Spot 6	LHCP	18383.00	Yes
77	10.5	Regional Return	R29	LHCP	29733.00	Spot 10	LHCP	18383.00	Yes
78	10.5	Regional Return	R5	LHCP	29733.00	Spot 13	LHCP	18383.00	Yes
79	10.5	Regional Return	R7	LHCP	29733.00	Spot 14	LHCP	18383.00	Yes
80	10.5	Regional Return	R3	LHCP	29733.00	Spot 16	LHCP	18383.00	Yes
81	10.5	Regional Return	R20	LHCP	29733.00	Spot 18	LHCP	18383.00	Yes
82	10.5	Regional Return	R31	LHCP	29733.00	Spot 19	LHCP	18383.00	Yes
83	10.5	Regional Return	R14	LHCP	29733.00	Spot 21	LHCP	18383.00	Yes
84	10.5	Regional Return	R1	LHCP	29733.00	Spot 22	LHCP	18383.00	Yes
85	10.5	Regional Return	R12	LHCP	29733.00	Spot 25	LHCP	18383.00	Yes
86	10.5	Regional Return	R22	LHCP	29733.00	Spot 27	LHCP	18383.00	Yes
87	10.5	Regional Return	R26	LHCP	29733.00	Spot 34	LHCP	18383.00	Yes
88	10.5	Regional Return	R27	LHCP	29733.00	Spot 35	LHCP	18383.00	Yes
89	10.5	Regional Return	R24	LHCP	29733.00	Spot 41	LHCP	18383.00	Yes
90	60	Regional Forward	Spot 2	RHCP	29655.00	R10	RHCP	18662.00	No
91	60	Regional Forward	Spot 3	RHCP	29655.00	R18	RHCP	18662.00	No
92	60	Regional Forward	Spot 5	RHCP	29655.00	R16	RHCP	18662.00	No
93	60	Regional Forward	Spot 6	RHCP	29655.00	R9	RHCP	18770.00	No
94	60	Regional Forward	Spot 10	RHCP	29655.00	R29	RHCP	18662.00	No
95	60	Regional Forward	Spot 13	RHCP	29655.00	R5	RHCP	18770.00	No
96	60	Regional Forward	Spot 14	RHCP	29655.00	R7	RHCP	18770.00	No
97	60	Regional Forward	Spot 16	RHCP	29655.00	R3	RHCP	18770.00	No
98	60	Regional Forward	Spot 18	RHCP	29655.00	R20	RHCP	18770.00	No
99	60	Regional Forward	Spot 19	RHCP	29655.00	R31	RHCP	18662.00	No
100	60	Regional Forward	Spot 21	RHCP	29655.00	R14	RHCP	18662.00	No
101	60	Regional Forward	Spot 22	RHCP	29655.00	R1	RHCP	18770.00	No
102	60	Regional Forward	Spot 25	RHCP	29655.00	R12	RHCP	18662.00	No
103	60	Regional Forward	Spot 27	RHCP	29655.00	R22	RHCP	18770.00	No
104	60	Regional Forward	Spot 34	RHCP	29655.00	R26	RHCP	18770.00	No
105	60	Regional Forward	Spot 35	RHCP	29655.00	R27	RHCP	18662.00	No
106	60	Regional Forward	Spot 41	RHCP	29655.00	R24	RHCP	18770.00	No

Table A.4-1 cont). SkyTerra-1 Frequency, Polarization and Beam Connectivity Plan

TXP #	BW (MHz)	Path Description	UPLINK			DOWNLINK			TWTA Shared?
			Beam	POL	Fc	Beam	POL	Fc	
107	292	Spot Forward	Spot 2	RHCP	29406.00	Spot 2	LHCP	19851.00	Yes
108	292	Spot Forward	Spot 3	RHCP	29406.00	Spot 3	LHCP	19851.00	Yes
109	292	Spot Forward	Spot 5	RHCP	29406.00	Spot 5	LHCP	19851.00	Yes
110	292	Spot Forward	Spot 6	RHCP	29406.00	Spot 6	LHCP	19851.00	Yes
111	292	Spot Forward	Spot 10	RHCP	29406.00	Spot 10	LHCP	19851.00	Yes
112	292	Spot Forward	Spot 11	RHCP	29406.00	Spot 11	LHCP	19851.00	Yes
113	292	Spot Forward	Spot 13	RHCP	29406.00	Spot 13	LHCP	19851.00	Yes
114	292	Spot Forward	Spot 14	RHCP	29406.00	Spot 14	LHCP	19851.00	Yes
115	292	Spot Forward	Spot 16	RHCP	29406.00	Spot 16	LHCP	19851.00	Yes
116	292	Spot Forward	Spot 18	RHCP	29406.00	Spot 18	LHCP	19851.00	Yes
117	292	Spot Forward	Spot 19	RHCP	29406.00	Spot 19	LHCP	19851.00	Yes
118	292	Spot Forward	Spot 21	RHCP	29406.00	Spot 21	LHCP	19851.00	Yes
119	292	Spot Forward	Spot 22	RHCP	29406.00	Spot 22	LHCP	19851.00	Yes
120	292	Spot Forward	Spot 23	RHCP	29406.00	Spot 23	LHCP	19851.00	Yes
121	292	Spot Forward	Spot 25	RHCP	29406.00	Spot 25	LHCP	19851.00	Yes
122	292	Spot Forward	Spot 27	RHCP	29406.00	Spot 27	LHCP	19851.00	Yes
123	292	Spot Forward	Spot 31	RHCP	29406.00	Spot 31	LHCP	19851.00	Yes
124	292	Spot Forward	Spot 34	RHCP	29406.00	Spot 34	LHCP	19851.00	Yes
125	292	Spot Forward	Spot 35	RHCP	29406.00	Spot 35	LHCP	19851.00	Yes
126	292	Spot Forward	Spot 36	RHCP	29406.00	Spot 36	LHCP	19851.00	Yes
127	292	Spot Forward	Spot 41	RHCP	29406.00	Spot 41	LHCP	19851.00	Yes
128	185	CONUS Forward	Spot 2	RHCP	28398.125	CONUS	RHCP	20028.125	No
129	185	CONUS Forward	Spot 16	RHCP	28444.375	CONUS	LHCP	20074.375	No
130	185	CONUS Forward	Spot 18	RHCP	28490.625	CONUS	LHCP	20120.625	No
131	185	CONUS Forward	Spot 35	RHCP	28536.875	CONUS	RHCP	20166.875	No

A.5 SATELLITE TRANSMIT CAPABILITY

A.5.1 CONUS Downlink Beam

The SkyTerra-1 satellite has the capability of supporting “broadcast” services to all of CONUS through its CONUS beam. The CONUS beam transmits in both RHCP and LHCP. The beam has a peak antenna gain of 36.0 dBi. The CONUS Forward uplink signal is received by one of the satellite’s Spot beam receive antennas. The signal is then down-converted, passed to two 260 Watt Dual TWTAs (“DTWTAs”) (i.e., the equivalent of four 130W TWTA amplifiers for 27.2 dBW total power), filtered and passed on to the CONUS transmit feed horns/antennas. The losses between the DTWTA output and the antenna input amount to 2.5 dB. The resulting beam peak saturated EIRP level for these transponders will be 60.7 dBW (i.e., 36+27.2-2.5). The cross-polar isolation of the CONUS transmit antennas will exceed 30 dB.

Although the CONUS beam transmits in both RHC and LHC polarizations, it does not do so on the same frequency. Therefore the SkyTerra-1 satellite's CONUS beam does not meet the requirements for full frequency re-use of the spectrum as required by Section 25.210(d) of the Commission's Rules. However, the SkyTerra-2 satellite's CONUS beam transmits on the same frequencies and in the opposite polarizations of the SkyTerra-1 satellite's CONUS beam. When the two satellites are co-located, the collective satellite system does provide full frequency re-use of the spectrum at the 95°W.L. location. SkyTerra requests a waiver of Section 25.210(d) for the SkyTerra-1 satellite's CONUS beam to the extent it is necessary.

Figure A.5-1. SkyTerra-1 CONUS downlink beam at 95° W.L.

(Contours shown are -2, -4, -6, -8, -10, -15, and -20 dB relative to the beam peak)

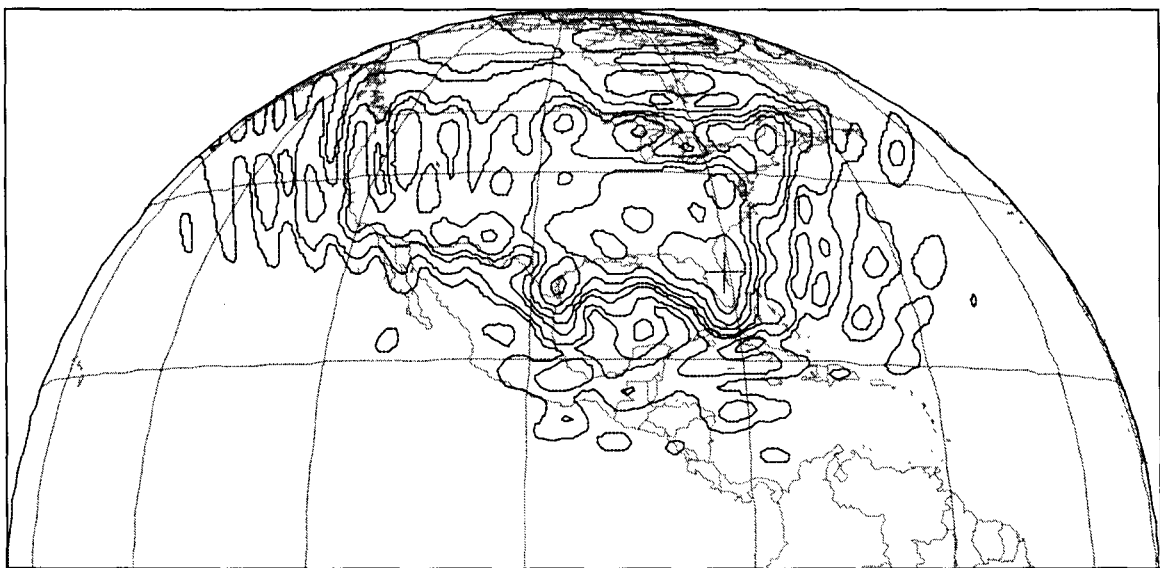

A.5.2 Downlink Regional Beams

The SkyTerra satellite system will employ 32 Regional beams: 17 beams on the SkyTerra-1 satellite and 15 beams on the SkyTerra-2 satellite. A four frequency re-use pattern is used between the two satellites. A two frequency re-use pattern is used by each individual satellite and is achieved through spatially separated beams. All Regional beams on the SkyTerra-1 satellite transmit using RHCP only. Figures A.5-1 and A.5-2 show the locations of the Regional beams for the SkyTerra-1 and SkyTerra-2 satellites, respectively. Figure A.5-3 shows the gain contours of one of the Regional beams.

The 17 Regional beams are nominally identical, and each has a peak antenna gain of 46.1 dBi. Regional Forward uplink signals are received by one of the satellite's Spot beams. The signal is then down-converted, filtered, and passed to a single, dedicated 60W TWTA (17.8 dBW) where it is then amplified, filtered and passed to the corresponding Regional downlink beam. The losses between the TWTA output and the Regional beam antenna input amount to 2.1 dB. The resulting beam peak saturated EIRP level for each Regional beam on the Regional Forward path is 61.8 dBW (i.e., $46.1+17.8-2.1$). The cross-polar isolation of the Regional beam transmit antennas will exceed 30 dB within the -4 dB gain contour at all transmit frequencies.

Figure A.5-2. SkyTerra-1 Regional and Spot Beam Locations.

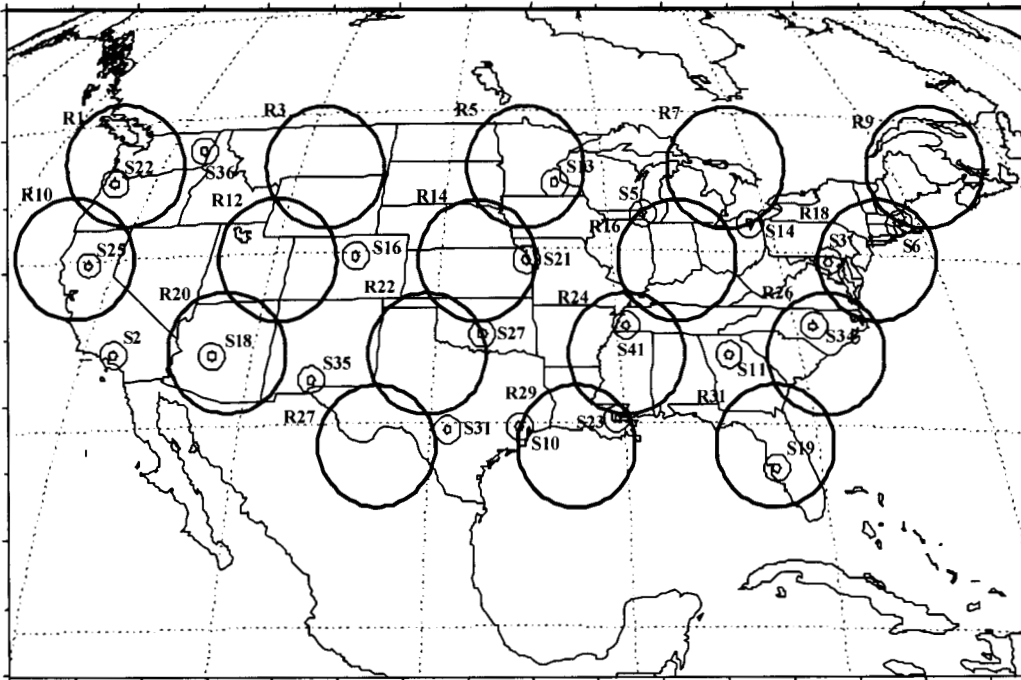

Figure A.5-3. SkyTerra-2 Regional and Spot Beam Locations.

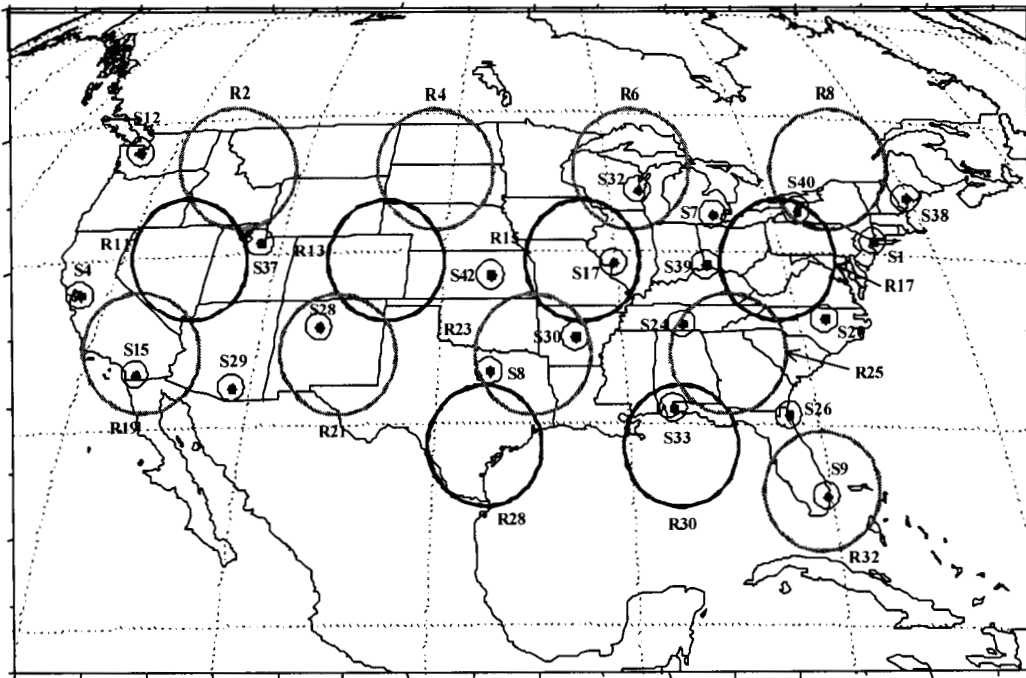
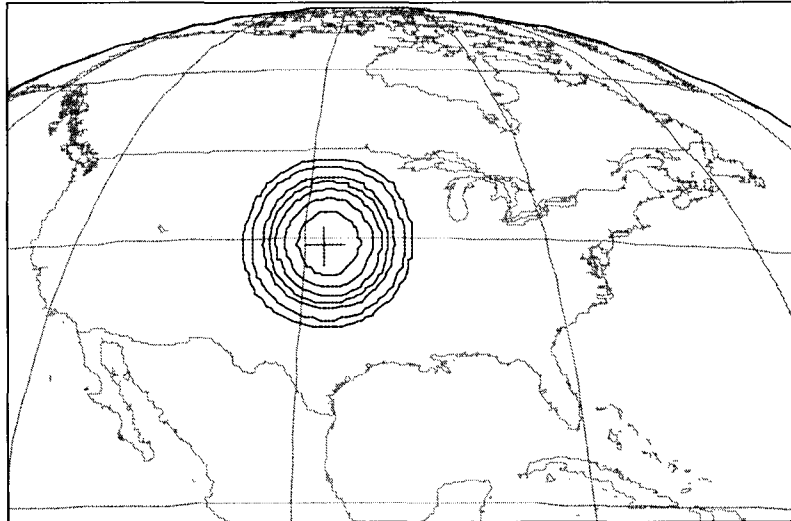

Figure A.5-4. Regional Beam Downlink Gain Contours - Sample Beam.
(Contours shown are -2, -4, -6, -8, -10, -15, and -20 dB relative to the beam peak)



A.5.3 Downlink Spot Beams

The SkyTerra satellite system will employ 42 Spot beams: 21 beams on each of the SkyTerra satellites. A two-times frequency re-use pattern is used between the two satellites. The SkyTerra-1 satellite achieves full frequency re-use through the use of spatially separated beams. All Spot beams on the SkyTerra-1 satellite transmit using LHCP only. Figures A.5-1 and A.5-2 show the locations of the Spot beams for the SkyTerra-1 and SkyTerra-2 satellites, respectively. Figure A.5-5 shows the gain contours of one of the Spot beams. The 21 spot beams are nominally identical, and each has a peak antenna gain of 52.2 dBi.

Each downlink Spot beam supports either two or three uplink paths: Regional Return, Spot Forward and Spot Return. The Regional Return uplink signal originates within one of the Regional beams while the Spot Forward and Spot Return uplink signals originate within one of the Spot beams. All received uplink signals from the two or three uplink paths are first down-converted, filtered, and passed to a diplexor or triplexor, as appropriate, where they are combined. The combined signal is then amplified, filtered and passed to the corresponding downlink Spot beam. The TWTA for each spot beam ranges in size from 25W to 100W. The

TWTA size for each Spot beam is selected to meet availability requirements in the various rain regions within CONUS. The losses between the TWTA output and the input to the Spot beam antenna amount to 2.5 dB. The maximum EIRP level for each Spot beam is provided in Schedule S. The cross-polar isolation of the Spot beam transmit antennas will exceed 30 dB within the -4 dB gain contour at all transmit frequencies.

Figure A.5-5. Spot Beam Downlink Gain Contours - Sample Beam.

(Contours shown are -2, -4, -6, -8, -10, -15, and -20 dB relative to the beam peak)

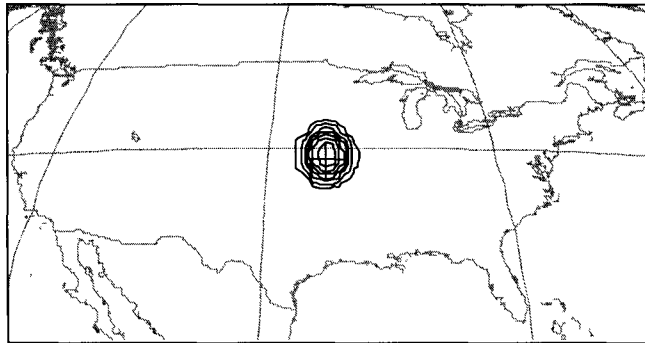

A.6 SATELLITE RECEIVE CAPABILITY

A.6.1 Uplink Regional Beams

The SkyTerra satellite system will employ 32 Regional beams: 17 beams on the SkyTerra-1 satellite and 15 beams on the SkyTerra-2 satellite. A four frequency re-use pattern is used between the two satellites. A two frequency re-use pattern is used by each individual satellite and is achieved through spatially separated beams. All uplink Regional beams on the SkyTerra-1 satellite operate using LHCP only. The locations of the uplink Regional beams are shown in Figure A.5-2. Figure A.6-1 shows the gain contours of one of the uplink Regional beams.

All uplink Regional beams are nominally identical, each with a peak gain of 46.1 dBi. The receive system noise temperature is 826 K and the beam peak G/T performance is +16.9 dB/K. The cross-polar isolation of the satellite receive antennas will exceed 30 dB within the -4 dB gain contour at all receive frequencies.

Figure A.6-1. Regional Beam Uplink Gain Contours - Sample Beam.
(Contours shown are -2, -4, -6, -8, -10, -15, and -20 dB relative to the beam peak)

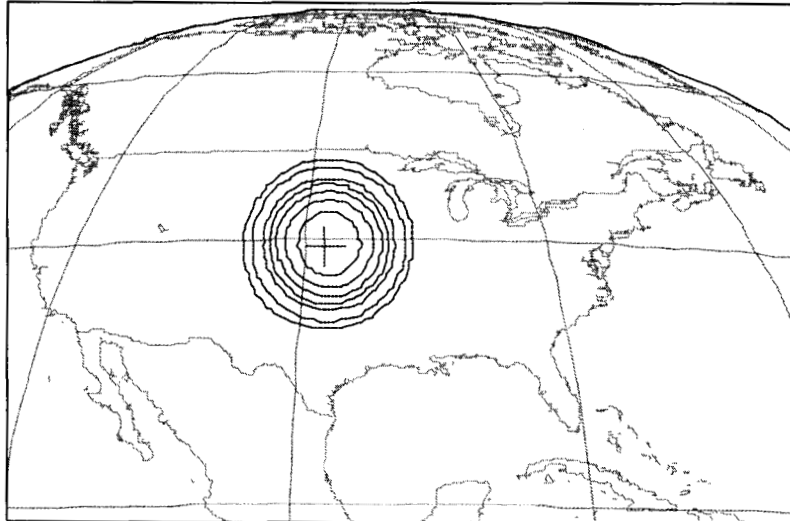

A.6.2 Uplink Spot Beams

The SkyTerra satellite system will employ 42 uplink Spot beams: 21 beams on each of the SkyTerra satellites. A two-times frequency re-use pattern is used between the two satellites. The SkyTerra-1 satellite achieves full frequency re-use through the use of spatially separated Spot beams. All receive Spot beams on the SkyTerra-1 satellite operate using RHCP only. Figure A.5-2 shows the locations of the Spot beams. Figure A.6-1 shows the gain contours of one of the uplink Spot beams. The 21 spot beams are nominally identical, and each has a peak antenna gain of 55.2 dBi.

The satellite receive system noise temperature is 741 K and the beam peak G/T performance is +26.5 dB/K. The cross-polar isolation of the satellite receive antennas will exceed 30 dB within the -4 dB gain contour at all receive frequencies.

Figure A.5-5. Spot Beam Downlink Gain Contours - Sample Beam.

(Contours shown are -2, -4, -6, -8, -10, -15, and -20 dB relative to the beam peak)

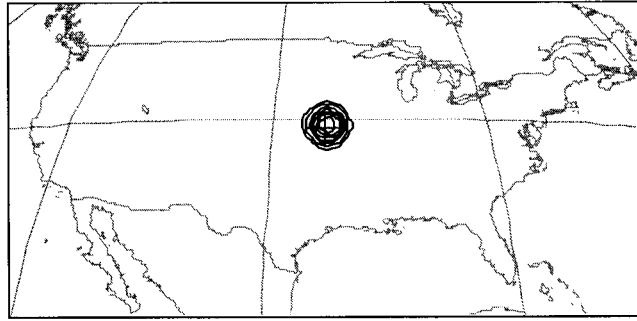

A.7 COMMUNICATIONS PAYLOAD AND TRANSMISSION SCHEME

The satellite design will utilize a simple bent-pipe architecture using Multi-Frequency Time-Division Multiple Access (“MF-TDMA”) based on the ETSI DVB-S and DVB-RCS standards. There will be no on-board processing of the communication signals on the SkyTerra satellites. Uplink beam to downlink beam connectivity is fixed. A block diagram of the communication subsystem is shown in Figure A.7-1.

Figure A.7-1. Communications Subsystem Block Diagram.

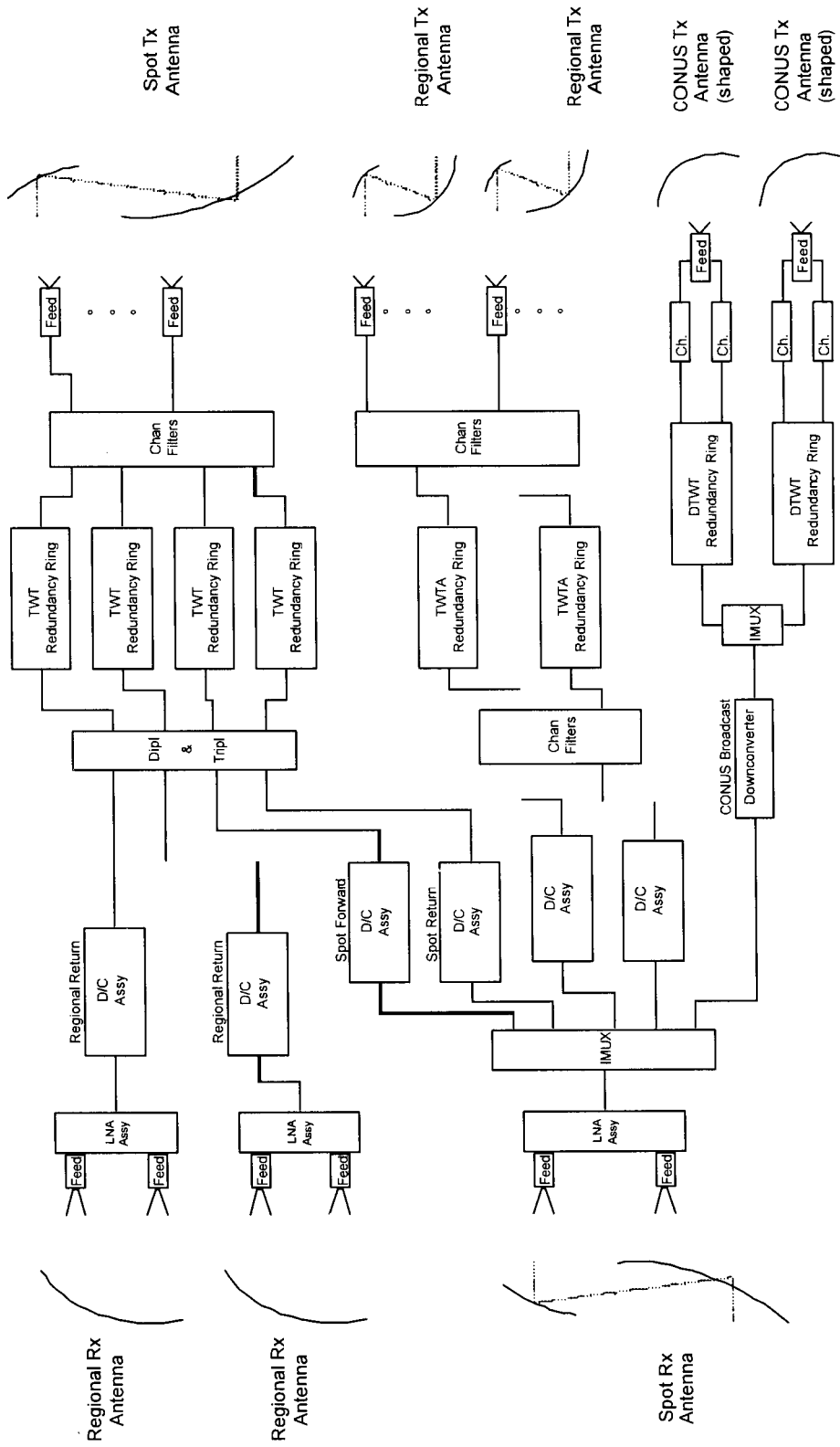

A.8 TRANSPONDER GAIN CONTROL AND SATURATION FLUX DENSITY

All transponders will be operated in a fixed gain mode. The receive chain of all receive beams includes an attenuator, which is programmable by ground command across a 15 dB range in 1 dB steps.

The minimum SFD and maximum transponder gains for each beam type are included in the Schedule S form. The SFDs and transponders gains vary over the 15 dB attenuation range. Additional comments regarding the assumptions of the SFD and transponder gain calculations are provided in section A.21.

A.9 SATELLITE TRANSPONDER FILTER RESPONSE

The specification for the overall transponder in-band filter response and out-of-band attenuation is dictated by the following considerations:

- 1) The in-band gain and group delay response must be flat enough so as not to degrade significantly the bit error rate performance of the digital carrier(s) in the transponder;
- 2) The out-of-band attenuation must be high enough, in the adjacent transponder frequency band, to suppress adequately the multi-path transmission through adjacent transponders.
- 3) The out-of-band attenuation must also be sufficient to suppress any unwanted signals in frequency bands adjacent to the transponder frequency band, which could otherwise cause overload of the active amplifiers in the communications payload, or waste the available power of the TWTAs.

A.10 UNWANTED EMISSIONS

The out-of-band emissions will not exceed the limits of §25.202(f) (1), (2) and (3).

A.11 EMISSION DESIGNATORS AND ALLOCATED BANDWIDTH OF EMISSIONS

The allocated bandwidths and emission designators used by the SkyTerra system are given in Table A.11-1.

Table A.11-1. SkyTerra-1 Signal and Emission Designators

Signal	Allocated Bandwidth of Emission	Emission Designator
Spot Return	2.7 MHz	2M70G7W
Regional Return	248 kHz	248KG7W
Regional Forward	60 MHz	60M0G7W
Spot Forward	36.5 MHz	36M5G7W
CONUS Forward	46.25 MHz	46M3G7W
TT&C, TM	500 kHz	500KG1D
TT&C, TC	500 kHz	500KF1D

A.12 EARTH STATIONS

The primary subscriber Ka-band transmit/receive earth station to be used with the SkyTerra satellites will be a 65 cm antenna. Such terminals are expected to be deployed in large numbers across the service areas (several millions). In some areas and for certain applications, where higher clear-sky performance is required, larger antennas may be used (typically 90 cm, 120 cm, or 150 cm).

In addition there will be a small number of medium to large gateway earth stations that are used for aggregating and uplinking local programming and transporting signals back to the terrestrial networks, such as for Internet connections. These gateway stations will typically use an antenna of 8.1 meters.

A.13 LINK BUDGETS

Table A.13-1 through A.13-5 provide representative link budgets for each type of emission used by the SkyTerra system. For the Regional Return, Spot Return and Spot Forward paths, two sets

of link budgets are provided representing the two extreme ends of the available TWTA power for the downlink Spot beams: one link budget for a high rain rate zone and one for a low rain rate zone.

End-to-end link availabilities are generally in excess of 99.6%. For certain links, the availability is slightly lower (> 99.5%) in those CONUS geographical areas within ITU rain zone N and where a 65 cm receive antenna has been assumed.

The transfer orbit and on-station TT&C link budgets are provided in Tables A.13-6 through A.13.9.

Table A.13-1. Representative Spot Return Link Budget (2M70G7W)

Link Parameters		Clear Sky High Downlink EIRP High Rain Rate Zone	Clear Sky Low Downlink EIRP Low Rain Rate Zone
Carrier			
Data Rate	(Mbps)	3.110	3.110
Modulation		QPSK	QPSK
FEC		0.691	0.691
Bandwidth	(dB-Hz)	64.3	64.3
Uplink			
Uplink Frequency	(MHz)	29,872	29,872
Tx E/S Antenna Diameter	(m)	0.65	0.65
Tx E/S Power to Antenna	(dBW)	4.0	4.0
Input Power Density	(dBW/Hz)	-60.3	-60.3
Tx E/S Antenna Gain	(dB)	43.2	43.2
Tx E/S EIRP per Carrier	(dBW)	47.2	47.2
Mispointing Error	(dB)	0.3	0.3
Atmospheric Losses	(dB)	0.5	0.5
Free Space Loss	(dB)	213.7	213.7
Satellite Antenna Gain (- 3dB)	(dBi)	52.2	52.2
Satellite Antenna G/T (-3 dB)	(dB/K)	23.5	23.5
(C/I) Up - Intra-system	(dB)	23.0	23.0
Downlink			
Downlink Frequency	(MHz)	18,522	18,522
Downlink EIRP (-3 dB)	(dBW)	35.8	29.8
Beam Peak EIRP Density	(dBW/Hz)	-25.5	-31.5
Atmospheric Losses	(dB)	0.3	0.3
Free Space Loss	(dB)	209.5	209.5
Rx E/S Antenna Diameter	(m)	8.10	8.10
Antenna Mispointing Error	(dB)	0.50	0.50
Rx E/S Antenna Gain	(dB)	61.4	61.4
Rx E/S G/T	(dB/K)	37.7	37.7
System Noise Temp.	(K)	232	232
(C/I) Dn - Intra-system	(dB)	20.0	20.0
End-to-End			
(C/N) - Thermal Uplink	(dB)	20.5	20.5
(C/N) - Thermal Downlink	(dB)	27.5	21.5
(C/I) Up - ASI	(dB)	16.2	16.2
(C/I) Dn - ASI	(dB)	31.6	25.6
(C/N+I) - Total Actual	(dB)	13.0	12.4
(C/N+I) - Total Required	(dB)	5.1	5.1
System Margin	(dB)	7.9	7.3

Table A.13-2. Representative Regional Return Link Budget (248KG7W)

Link Parameters	Clear Sky High Downlink EIRP High Rain Rate Zone	Clear Sky Low Downlink EIRP Low Rain Rate Zone
Carrier		
Data Rate (Mbps)	0.286	0.286
Modulation	QPSK	QPSK
FEC	0.691	0.691
Bandwidth (dB-Hz)	54.0	54.0
Uplink		
Uplink Frequency (MHz)	29,795	29,795
Tx E/S Antenna Diameter (m)	0.65	0.65
Tx E/S Power to Antenna (dBW)	-3.5	-3.5
Input Power Density (dBW/Hz)	-57.5	-57.5
Tx E/S Antenna Gain (dB)	43.2	43.2
Tx E/S EIRP per Carrier (dBW)	39.7	39.7
Mispointing Error (dB)	0.3	0.3
Atmospheric Losses (dB)	0.5	0.5
Free Space Loss (dB)	213.6	213.6
Satellite Antenna Gain (- 3dB) (dBi)	43.1	43.1
Satellite Antenna G/T (-3 dB) (dB/K)	13.9	13.9
(C/I) Up - Intra-system (dB)	27.5	27.5
Downlink		
Downlink Frequency (MHz)	18,445	18,445
Downlink EIRP (-3 dB) (dBW)	26.6	20.6
Beam Peak EIRP Density (dBW/Hz)	-24.4	-30.4
Atmospheric Losses (dB)	0.3	0.3
Free Space Loss (dB)	209.5	209.5
Rx E/S Antenna Diameter (m)	8.10	8.10
Antenna Mispointing Error (dB)	0.50	0.50
Rx E/S Antenna Gain (dB)	61.4	61.4
Rx E/S G/T (dB/K)	37.7	37.7
System Noise Temp. (K)	232	232
(C/I) Dn - Intra-system (dB)	22.0	22.0
End-to-End		
(C/N) - Thermal Uplink (dB)	13.8	13.8
(C/N) - Thermal Downlink (dB)	28.7	22.7
(C/I) Up - ASI (dB)	19.1	19.1
(C/I) Dn - ASI (dB)	32.8	26.8
(C/N+I) - Total Actual (dB)	12.0	11.6
(C/N+I) - Total Required (dB)	5.1	5.1
System Margin (dB)	6.9	6.5

Table A.13-3. Representative Regional Forward Link Budget (60M0G7W)

Link Parameters	Clear Sky
Carrier	
Data Rate (Mbps)	69.100
Modulation	QPSK
FEC	0.691
Bandwidth (dB-Hz)	77.8
Uplink	
Uplink Frequency (MHz)	29,655
Tx E/S Antenna Diameter (m)	8.10
Tx E/S Power to Antenna (dBW)	7.4
Input Power Density (dBW/Hz)	-70.4
Tx E/S Antenna Gain (dB)	62.9
Tx E/S EIRP per Carrier (dBW)	70.3
Mispointing Error (dB)	0.5
Atmospheric Losses (dB)	0.5
Free Space Loss (dB)	213.6
Satellite Antenna Gain (-3 dB) (dBi)	52.2
Satellite Antenna G/T (-3 dB) (dB/K)	23.5
(C/I) Up - Intra-system (dB)	24.0
Downlink	
Downlink Frequency (MHz)	18,716
Downlink EIRP (-3 dB) (dBW)	58.8
Beam Peak EIRP Density (dBW/Hz)	-16.0
Atmospheric Losses (dB)	0.3
Free Space Loss (dB)	209.6
Rx E/S Antenna Diameter (m)	0.65
Antenna Mispointing Error (dB)	0.30
Rx E/S Antenna Gain (dB)	40.3
Rx E/S G/T (dB/K)	19.1
System Noise Temp. (K)	132
(C/I) Dn - Intra-system (dB)	19.0
End-to-End	
(C/N) - Thermal Uplink (dB)	30.0
(C/N) - Thermal Downlink (dB)	18.5
(C/I) Up - ASI (dB)	25.7
(C/I) Dn - ASI (dB)	20.1
(C/N+I) - Total Actual (dB)	13.6
(C/N+I) - Total Required (dB)	5.1
System Margin (dB)	8.5

Table A.13-4. Representative Spot Forward Link Budget (36M5G7W)

Link Parameters		Clear Sky	Clear Sky
		High Downlink EIRP High Rain Rate Zone	Low Downlink EIRP Low Rain Rate Zone
Carrier			
Data Rate	(Mbps)	42	42
Modulation		QPSK	QPSK
FEC		0.691	0.691
Bandwidth	(dB-Hz)	75.6	75.6
Uplink			
Uplink Frequency	(MHz)	29,406	29,406
Tx E/S Antenna Diameter	(m)	8.10	8.10
Tx E/S Power to Antenna	(dBW)	5.0	5.0
Input Power Density	(dBW/Hz)	-70.6	-70.6
Tx E/S Antenna Gain	(dB)	62.9	62.9
Tx E/S EIRP per Carrier	(dBW)	67.9	67.9
Mispointing Error	(dB)	0.5	0.5
Atmospheric Losses	(dB)	0.5	0.5
Free Space Loss	(dB)	213.5	213.5
Satellite Antenna Gain (- 3dB)	(dBi)	52.2	52.2
Satellite Antenna G/T (-3 dB)	(dB/K)	23.5	23.5
(C/I) Up - Intra-system	(dB)	21.0	21.0
Downlink			
Downlink Frequency	(MHz)	19,851	19,851
Downlink EIRP (-3 dB)	(dBW)	56.6	50.6
Beam Peak EIRP Density	(dBW/Hz)	-16.0	-22.0
Atmospheric Losses	(dB)	0.3	0.3
Free Space Loss	(dB)	210.1	210.1
Rx E/S Antenna Diameter	(m)	0.65	0.65
Antenna Mispointing Error	(dB)	0.30	0.30
Rx E/S Antenna Gain	(dB)	40.3	40.3
Rx E/S G/T	(dB/K)	19.1	19.1
System Noise Temp.	(K)	132	132
(C/I) Dn - Intra-system	(dB)	19.0	19.0
End-to-End			
(C/N) - Thermal Uplink	(dB)	29.9	29.9
(C/N) - Thermal Downlink	(dB)	18.0	12.0
(C/I) Up - ASI	(dB)	25.6	25.6
(C/I) Dn - ASI	(dB)	16.6	10.6
(C/N+I) - Total Actual	(dB)	12.1	7.6
(C/N+I) - Total Required	(dB)	5.1	5.1
System Margin	(dB)	7.0	2.5

Table A.13-5. Representative CONUS Forward Link Budget (46M3G7W)

Link Parameters	Clear Sky
Carrier	
Data Rate (Mbps)	53.264
Modulation	QPSK
FEC	0.691
Bandwidth (dB-Hz)	76.7
Uplink	
Uplink Frequency (MHz)	28,444
Tx E/S Antenna Diameter (m)	8.10
Tx E/S Power to Antenna (dBW)	5.0
Input Power Density (dBW/Hz)	-71.7
Tx E/S Antenna Gain (dB)	62.9
Tx E/S EIRP per Carrier (dBW)	67.9
Mispointing Error (dB)	0.5
Atmospheric Losses (dB)	0.5
Free Space Loss (dB)	213.2
Satellite Antenna Gain (-3 dB) (dBi)	52.2
Satellite Antenna G/T (-3 dB) (dB/K)	23.5
(C/I) Up - Intra-system (dB)	32.0
Downlink	
Downlink Frequency (MHz)	20,074
Downlink EIRP (-3 dB) (dBW)	57.7
Beam Peak EIRP Density (dBW/Hz)	-16.0
Atmospheric Losses (dB)	0.3
Free Space Loss (dB)	210.2
Rx E/S Antenna Diameter (m)	0.65
Antenna Mispointing Error (dB)	0.30
Rx E/S Antenna Gain (dB)	40.3
Rx E/S G/T (dB/K)	19.1
System Noise Temp. (K)	132
(C/I) Dn - Intra-system (dB)	28.2
End-to-End	
(C/N) - Thermal Uplink (dB)	29.1
(C/N) - Thermal Downlink (dB)	17.9
(C/I) Up - ASI (dB)	24.8
(C/I) Dn - ASI (dB)	16.5
(C/N+I) - Total Actual (dB)	13.5
(C/N+I) - Total Required (dB)	5.1
System Margin (dB)	8.4

Table A.13-6. Command Link Budget (Transfer Orbit and Emergency Operations)

Command Link Budget (Transfer and Emergency)			
Link Parameters		Nom. U/L	Low U/L
Frequency	(MHz)	5,926.5	5,926.5
Incident Flux Density	(dBW/m ²)	-85.0	-90.0
Aperture Factor	(dB-m ²)	-36.9	-36.9
Incident Isotropic Power	(dBW)	-121.9	-126.9
Antenna Gain	(dBi)	-4.0	-4.0
Noise Temperature	(dB-K)	30.0	30.0
Satellite G/T	(dB/K)	-34.0	-34.0
Receive Losses	(dB)	-8.5	-8.5
Receiver Input Power	(dBm)	-104.4	-109.4
Receiver Threshold	(dBm)	-112.0	-112.0
Spacecraft Margin	(dB)	7.6	2.6

Table A.13-7: Telemetry Link Budget (Transfer Orbit and Emergency Operations)

Telemetry Link Budget (Transfer and Emergency)		
Link Parameters		
Frequency	(MHz)	3,701
Transmit Power	(dBW)	15.7
Line Losses	(dB)	3.6
Antenna Gain, EOC	(dBi)	-4.0
EIRP	(dBW)	8.1
Free Space path Loss	(dB)	195.5
Rx E/S G/T	(dB/K)	24.5
Downlink C/N	(dB)	13.7
C/N Required	(dB)	9.0
Margin	(dB)	4.7

Table A.13-8: Command Link Budget (On-Station Operations)

Command Link Budget (On-Station)			
Link Parameters		Nom. U/L	Low U/L
Frequency	(MHz)	29,999.5	29,999.5
Incident Flux Density	(dBW/m ²)	-110.0	-120.0
Aperture Factor	(dB-m ²)	-51.0	-51.0
Incident Isotropic Power	(dBW)	-161.0	-171.0
Antenna Gain (Peak)	(dBi)	55.2	55.2
Noise Temperature	(dB-K)	28.7	28.7
Satellite G/T	(dB/K)	26.5	26.5
Receive Losses	(dB)	-23.6	-23.6
Receiver Input Power	(dBm)	-99.4	-109.4
Receiver Threshold	(dBm)	-112.0	-112.0
Spacecraft Margin	(dB)	12.6	2.6

The Satellite Operations Center (“SOC”) will provide TT&C operations. The on-station command will uplink through one of the Spot beams. The site for the SOC operations has not yet been selected and therefore it is not possible to know which of the 21 Spot beams will be used to receive the command signals. For purposes of completing the Schedule S form, the on-station command transmissions have been assumed to be received by Spot beam number 2.

Table A.13-9: Telemetry Link Budget (On-Station Operations)

Telemetry Link Budget (On-Station)		
Link Parameters		
Frequency	(MHz)	20,198
Transmit Power	(dBW)	-5.0
Line Losses	(dB)	2.8
Antenna Gain, EOC	(dBi)	25.0
EIRP	(dBW)	17.2
Free Space path Loss	(dB)	210.4
Rx E/S G/T	(dB/K)	37.7
Downlink C/N	(dB)	21.1
C/N Required	(dB)	10.4
Margin	(dB)	10.7

A.14 POWER FLUX DENSITY AT THE EARTH'S SURFACE

§25.208(c) contains FSS Power Flux Density (“PFD”) limits that apply in the 18.3-18.8 GHz band. The PFD limits of §25.208(c) are as follows:

- -115 dB (W/m²) in any 1 MHz band for angles of arrival between 0 and 5 degrees above the horizontal plane;
- $-115+(d-5)/2$ dB (W/m²) in any 1 MHz band for angles of arrival d (in degrees) between 5 and 25 degrees above the horizontal plane; and
- -105 dB (W/m²) in any 1 MHz band for angles of arrival between 25 and 90 degrees above the horizontal plan

In addition, §25.208(d) contains FSS Power Flux Density (“PFD”) limits that apply in the 18.6-18.8 GHz band produced by emissions form a space station under assumed free-space propagation conditions as follows:

- -95 dB(W/m²) for all angles of arrival. This limit may be exceeded by up to 3 dB for no more than 5% of the time.

Compliance with these limits is demonstrated below using a simple worst-case methodology. From the link budgets, the maximum downlink EIRP density of any carrier is -16.0 dBW/Hz or 44 dBW/MHz. This limitation is due to designed power limitations for the CONUS and Regional beams and, in the case of the Spot beams, the downlink EIRP density is a controlled value. The shortest distance from the satellite to the Earth is 35,786 km, corresponding to a spreading loss of 162.06 dB. Therefore the maximum possible PFD at the Earth’s surface cannot exceed $44 - 162.06 = -118.06$ dBW/m². This is less than the PFD limit value of -115 dBW/m²/MHz that applies at the low elevation angles (5° and below).¹ Therefore compliance with the PFD limits is assured.

In addition, §25.208(d) provides an additional aggregate PFD limit in the 200 MHz wide band 18.6-18.8 GHz of -95 dBW/m². In the worst case this would correspond to a PFD limit per

¹ It should be noted that the maximum PFD value is also below the value given in §25.138 (a)(6) for blanket licensing of small user terminals.

MHz of $-118 \text{ dBW/m}^2/\text{MHz}$ (i.e., $-95 - 10 \cdot \log(200 \text{ MHz})$). Therefore, based on the worst-case calculation in the preceding paragraph, compliance with the §25.208(d) is also assured.

A.15 CESSATION OF EMISSIONS

Each satellite transponder can be individually turned on and off by ground telecommand, thereby causing cessation of emissions from the satellite, as required.

A.16 TT&C ARRANGEMENTS

There are currently no global telemetry services available in the Ka-band frequency range to support the Launch and Early Operations (“LEOP”) phase of the SkyTerra program. A waiver request for use of C-band frequencies for the LEOP phase of the SkyTerra program is included within this application. SkyTerra proposes to use the C-band FSS frequencies for launch, initial orbit testing and for certain on-station emergency situations. When operating correctly on-station, the TT&C function will be switched to a higher gain satellite antenna to permit lower power TT&C transmissions on both uplink and downlink. SkyTerra intends to outsource its TT&C operations to an experienced satellite operator. Upon successful launch and in-orbit testing, SkyTerra will utilize the Ka-band frequencies for on-station TT&C operations.

The satellites will be configured to operate their TT&C functions through omni-directional spacecraft antennas during the LEOP, as well as in the event of a spacecraft emergency where attitude control might be disturbed.

Table A.16-1: Summary of the TT&C Subsystem Parameters

Parameter	Transfer Orbit and Emergency	On-Station
Command/Ranging Frequencies/Polarization	5926.5 MHz (H) 6424.5 MHz (V)	29,999.5 MHz (RHCP)
Uplink Flux Density	Between -85 and -90 dBW/m ²	Between -110 and -120 dBW/m ²
Uplink Antenna Coverage (relative to the +Z axis of the spacecraft, antenna boresight)	+Z ± 110° (E/W) x ± 50° (N/S) -Z ± 50° (E/W) x ± 50° (N/S)	Spot beam 0.206° beamwidth
Telemetry Frequencies	3701 MHz (H) 4199 MHz (V)	20,198 MHz (LHCP)
Downlink Antenna Coverage (relative to the +Z axis of the spacecraft, antenna boresight)	+Z ± 110° (E/W) x ● 50° (N/S) -Z ± 50° (E/W) x ● 50° (N/S)	6° beamwidth
Maximum Downlink EIRP	12.1 dBW	20.2 dBW

The satellite will also utilize a Radio Frequency Auto Tracking (“RFAT”) beacon subsystem. The center frequency of the RFAT beacon has not yet been finalized, but it is expected to use 500 kHz of spectrum near 29.995 GHz. Once the center frequency has been selected, SkyTerra will provide the necessary transmission information of the beacon and request authorization from the Commission. The satellite’s mass and power budgets contained in Schedule S take into account the RFAT subsystem.

A.17 SPACECRAFT CHARACTERISTICS

The SkyTerra-1 satellite is based on the Loral FS-1300X Omega platform. The spacecraft’s characteristics are provided in the Schedule S form.

Payload reliability is 0.9 and bus reliability is 0.89 with an overall spacecraft reliability of approximately 0.8. Transponder and receiver sparing will be consistent with documented failure rates that allow the attainment of the overall spacecraft reliability numbers listed above.

A.18 INTERFERENCE STATEMENT

Compliance with the FCC two-degree spacing policy is assured provided:

- 1) The maximum PFD levels are lower than the PFD values given in §25.138 (a)(6) of the Rules for blanket licensing of small user terminals;
- 2) The uplink off-axis EIRP density limits of §25.138 (a)(1) of the Rules are not exceeded.

Section A.14 showed the maximum PFD that can be transmitted by the SkyTerra-1 satellite at any angle of arrival is -118.06 dBW/m²/MHz. This value is lower than the PFD value given in §25.138 (a)(6) of the Rules for blanket licensing of small user terminals.

The clear sky uplink off-axis EIRP density limits are equivalent to a maximum uplink input power density of -56.5 dBW/Hz. Table A.18-1 compares the uplink input power densities derived from the uplink link budgets contained in Tables A.13-1 through A.13-5 (uplink antenna moved from the -3 dB to -4 dB contour) with the clear sky limits of §25.138 (a)(1) of the Rules. It can be seen that in all cases the clear sky uplink power limits are met, albeit with a zero margin in one case.

Table A.18-1 – Demonstration of Compliance with the Uplink Power limits of §25.138 (a)(1)

Uplink Antenna Size	Emission	Maximum Clear Sky Uplink Input Power Density (dBW/Hz)	Clear Sky Uplink Input Power Density Limit of §25.138 (a)(1) (dBW/Hz)	Excess Margin (dB)
65 cm	2M70G7W	-59.3	-56.5	2.8
65 cm	248KG7W	-56.5	-56.5	0
8.1 m	60M0G7W	-69.4	-56.5	12.9
8.1 m	36M5G7W	-69.6	-56.5	13.1
8.1 m	46M3G7W	-70.7	-56.5	14.2

No authorized uplink transmissions to the SkyTerra-1 satellite will exceed an input power density value of -56.5 dBW/Hz.

A.19 SHARING ANALYSIS WITH OTHER SERVICES AND ALLOCATIONS

FSS Stations licensed to use spectrum within the 18.3-18.8 GHz band are protected by virtue of the GSO FSS PFD limits contained in Section 25.208(c) of the Rules. Section A.14 (PFD) above demonstrates that the SkyTerra-1 satellite does not exceed the PFD limits of Section 25.208(c) of the Rules.

A.20 ORBITAL DEBRIS MITIGATION

SkyTerra and its satellite manufacturer have performed a careful assessment to determine that no debris will be released by the space station during normal on-station operations. As noted below, SkyTerra has taken measures to ensure a safe operational configuration of its satellite system through hardware design and operational procedures. Each section below addresses specific measures taken by SkyTerra, as required under §25.114(d)(14) of the Commission's rules, to limit the possibility that its space station operations will generate orbital debris.

A.20.1 Collisions with Small Debris

SkyTerra has assessed the probability of the space station becoming a source of debris by collisions with small debris or meteoroids that could cause loss of control and prevent post-mission disposal. Collisions with the background environment, including meteoroids, are considered as part of the satellite design. These effects are considered on a statistical basis to determine collision risk. SkyTerra's satellite manufacturer, Loral, includes meteoroid environments as part of the satellite Environmental Requirement Specifications. Literature is reviewed for large size space objects, particularly technical papers that present collision probability estimates for orbital conditions of interest. The satellite requirement was derived from these technical papers as well as NASA models to include debris and meteoroids of various sizes. SkyTerra has taken steps to limit the effects of such collisions through shielding, the judicious placement of components, and the use of redundant systems.

A.20.2 Accidental Explosions and Energy Sources

SkyTerra has assessed and limited the probability of accidental explosions during and after completion of mission operations. The satellite manufacturer has taken steps to ensure that debris generation will not result from the conversion of energy sources on board the satellite into energy that fragments the satellite. In particular, the satellite manufacturer advises that no structural failures of pressurized volumes have occurred on its satellites to date. Burst tests are performed on all pressure vessels during qualification testing to demonstrate a margin of safety against burst. Bipropellant mixing is prevented by the use of valves that prevent backwards flow in propellant lines and pressurization lines. Although NiH₂ batteries retain fluids in a pressure vessel, pressure at end-of-life is maintained at a low level, and procedures will be undertaken by SkyTerra to assure that the battery does not retain a charge at the end of the mission. Upon reaching the final disposal orbit, all propellants and pressurants will be vented utilizing the on-board thrusters.

A.20.3 Collisions with Large Debris or Operational Space Stations

SkyTerra will select an established launch agency with a proven record of safe flight planning and with the capability to analyze and minimize the possibilities of any collision with large debris during launch. The launch contractor will be responsible for collision avoidance maneuvers and launch analysis of in-flight profile planning.

SkyTerra has assessed and will limit the probability of the space station becoming a source of debris by collisions with other operational space stations. In considering operational and planned satellites that may have a station-keeping volume that overlaps the SkyTerra-1 and SkyTerra-2 satellites, SkyTerra reviewed the lists of FCC licensed systems and systems that are currently under consideration by the FCC. In addition, networks for which a request for coordination has been submitted to the ITU in the vicinity of 95° W.L., have also been reviewed. Only those networks that either operate, or are planned to operate, and can have an overlapping station-keeping volume with the SkyTerra-1 and SkyTerra-2 satellites, have been taken into account in the analysis.

Based on our review, the only FCC system licensed, or under consideration to be licensed by the FCC for operation at the 95° W.L. position is the PanAmSat GALAXY-3C satellite.

With regard to ITU filings in the immediate vicinity of 95°W.L., the ITU has published requests for coordination for the following non-US FSS networks:

- the Australian Ka-band ROEBUCK-A network;
- the Canadian expansion BSS band CAN-BSS-95.0 network;
- the French 2 GHz OPS-2 network;
- the Papua New Guinea V-band LOGOHU-V-265E network;
- the Trinidad L-band CARIBSS-1 network.

SkyTerra can find no evidence that satellite construction contracts have been awarded for any of these networks, nor does the Federal Aviation Administration Commercial Space Station Fourth Quarter 2004 Report show any pending launches satellites that match the above networks.

SkyTerra concludes that it will be necessary to physically coordinate its SkyTerra-1 and SkyTerra-2 satellites with PanAmSat. SkyTerra will begin coordination with PanAmSat approximately two years before the expected launch of the SkyTerra-1 satellite.

There are a number of potential flight dynamic solutions to be explored in consultation with PanAmSat to ensure avoidance of in-orbit collision between the satellites, including the possibility of operating the satellites at small angular offsets from their nominal position. In the event that a coordination agreement requires operation of the SkyTerra-1 and SkyTerra-2 satellites at an offset from the 95°W.L. location, SkyTerra will seek any necessary modifications to its authorization from the Commission.

The SkyTerra-1 and SkyTerra-2 satellites will be controlled by the same satellite operator and will be flown in a manner to ensure the two satellites cannot collide.

In the event that future satellites are authorized to operate in the immediate vicinity of 95°W.L., SkyTerra will coordinate the physical operation of its satellites with that satellite operator.

A.20.4 Post-Mission Disposal Plans

At the end of the operational life of the SkyTerra satellite, SkyTerra will maneuver the satellite to a disposal orbit with a minimum perigee of 300 km above the normal GSO operational orbit. This proposed disposal orbit altitude is based on the following calculation, as required by §25.283:

$$\text{Solar array area} = 60 \text{ m}^2$$

$$\text{Satellite body area (oriented for max antenna exposure)} = 4 \text{ m}^2$$

$$\text{Ka-band antenna area (east and west deployed)} = 14 \text{ m}^2$$

$$\text{Total Solar Pressure Area "A"} = 78 \text{ m}^2$$

$$\text{"M"} = \text{Dry Mass of Satellite} = 2499 \text{ kg}$$

$$\text{"C}_R\text{"} = \text{Solar Pressure Radiation Coefficient (worst case)} = 2$$

Therefore the Minimum Disposal Orbit Perigee Altitude is calculated to be:

$$\begin{aligned} & 36,021 \text{ km} + 1000 \times C_R \times A/m \\ = & 36,021 \text{ km} + 1000 \times 2 \times 78/2499 \\ = & 36,083.4 \text{ km} \\ = & 297.2 \text{ km above GSO (based on GSO @ 35,786.2)} \end{aligned}$$

To provide margin, the disposal orbit will be increased above this calculated value of 297 km to a value of 300 km.

The propulsion subsystem design and the satellite fuel budget account for the post-mission disposal of the satellite. 12 kg of propellant will be allocated and reserved for the final orbit raising maneuvers.

A.21 COMMENTS CONCERNING SCHEDULE-S SUBMISSION

In this section, SkyTerra provides additional explanation concerning specific areas of the Schedule S forms where some difficulties have been experienced in entering the technical characteristics of the SkyTerra-1 satellite. This is in part due to the non-traditional nature of the SkyTerra-1 satellite design, which does not necessarily comport well with all requirements of a Schedule S form, as well as apparent limitations of the Schedule S software itself. To the extent that the Commission considers any of the items below to be in non-compliance with Schedule S and/or Part 25 requirements, SkyTerra requests a waiver, based on the justification and explanation given below.

1. SFD and Transponder Gain Calculations (S7 and S10 in Schedule S):

- (i) The downlink Spot beams transmit the signals received from either two or three uplink paths. The associated Spot beam TWTA is used exclusively for multi-carrier operation and is therefore always operated in a backed-off manner. Any one of the two or three uplink paths cannot individually saturate the TWTA; therefore stating a saturating flux-density (“SFD”) is not meaningful. Nonetheless, for purposes of complying with the Commission’s rules, the SFD for the uplink Regional beams and uplink Spot beams has been calculated as if one of the uplink paths could saturate the TWTA. This minimum SFD was calculated to be -81.6 dBW/m^2 and this value appears in S7 of Schedule S for both the uplink Regional beams and uplink Spot beams. This minimum SFD appears to be a rather large value, but this is because it results from a significant amount of uplink bandwidth (and hence power). The maximum transponder gain is dependent on the minimum SFD value. For the Regional Return, Spot Return and Spot Forward paths, the maximum transponder gain, as stated in Schedule S, was calculated based upon the minimum SFD value of -81.6 dBW/m^2
- (ii) The Schedule S form was developed with the assumption that any one uplink beam would have a distinct SFD value. In the case of the SkyTerra satellites, most uplink Spot beams are connected to both a downlink Spot beam and a

downlink Regional beam. In addition, four uplink Spot beams are also connected to the CONUS downlink beam. The Regional Forward and CONUS Forward paths, both using uplink Spot beams and having dedicated TWTA's for the downlink, do have distinct SFD values, however they cannot be entered into Schedule S because we have already used the -81.6 dBW/m^2 value calculated above. In other words, multiple SFD values for the same uplink beam cannot be input into Schedule S. The minimum SFDs for the Regional Forward and CONUS Forward paths are -100.3 dBW/m^2 and -101.8 dBW , respectively.

2. It was found to be impossible to attach all the GXT files to the Schedule S form. The software "quit" after 27 files were attached and exhibited behavior that prevented any additional GXT files from being attached. We subsequently deleted the 27 GXT files and renumbered the SYSTEM_KEY manually. Only the CONUS and Ka-band telemetry beams ultimately have been included in the Schedule S form. SkyTerra will use other avenues to provide the Commission with all of the GXT files for each of the Regional and Spot beams.
3. S14 ("Other" tab in Schedule S): The address, telephone number and call sign of TT&C earth station is not yet available, but will be notified to the Commission in due course.

CERTIFICATION OF PERSON RESPONSIBLE FOR PREPARING
ENGINEERING INFORMATION

I hereby certify that I am the technically qualified person responsible for preparation of the engineering information contained in this pleading, that I am familiar with Part 25 of the Commission's Rules, that I have either prepared or reviewed the engineering information submitted in this pleading, and that it is complete and accurate to the best of my knowledge and belief.

/s/

Stephen D. McNeil

Telecomm Strategies Inc.
6404 Highland Drive
Chevy Chase, Maryland 20815
(301) 656-8969

Link Parameters		Clear Sky	Clear Sky
		High Downlink EIRP High Rain Rate Zone	Low Downlink EIRP Low Rain Rate Zone
Carrier			
Data Rate	(Mbps)	0.286	0.286
Modulation		QPSK	QPSK
FEC		0.691	0.691
Bandwidth	(dB-Hz)	54.0	54.0
Uplink			
Uplink Frequency	(MHz)	29,795	29,795
Tx E/S Antenna Diameter	(m)	0.65	0.65
Tx E/S Power to Antenna	(dBW)	-3.5	-3.5
Input Power Density	(dBW/Hz)	-57.5	-57.5
Tx E/S Antenna Gain	(dB)	43.2	43.2
Tx E/S EIRP per Carrier	(dBW)	39.7	39.7
Mispointing Error	(dB)	0.3	0.3
Atmospheric Losses	(dB)	0.5	0.5
Free Space Loss	(dB)	213.6	213.6
Satellite Antenna Gain (- 3dB)	(dBi)	43.1	43.1
Satellite Antenna G/T (-3 dB)	(dB/K)	13.9	13.9
(C/I) Up - Intra-system	(dB)	27.5	27.5
Downlink			
Downlink Frequency	(MHz)	18,445	18,445
Downlink EIRP (-3 dB)	(dBW)	26.6	20.6
Beam Peak EIRP Density	(dBW/Hz)	-24.4	-30.4
Atmospheric Losses	(dB)	0.3	0.3
Free Space Loss	(dB)	209.5	209.5
Rx E/S Antenna Diameter	(m)	8.10	8.10
Antenna Mispointing Error	(dB)	0.50	0.50
Rx E/S Antenna Gain	(dB)	61.4	61.4
Rx E/S G/T	(dB/K)	37.7	37.7
System Noise Temp.	(K)	232	232
(C/I) Dn - Intra-system	(dB)	22.0	22.0
End-to-End			
(C/N) - Thermal Uplink	(dB)	13.8	13.8
(C/N) - Thermal Downlink	(dB)	28.7	22.7
(C/I) Up - ASI	(dB)	19.1	19.1
(C/I) Dn - ASI	(dB)	32.8	26.8
(C/N+I) - Total Actual	(dB)	12.0	11.6
(C/N+I) - Total Required	(dB)	5.1	5.1
System Margin	(dB)	6.9	6.5

Link Parameters		Clear Sky High Downlink EIRP High Rain Rate Zone	Clear Sky Low Downlink EIRP Low Rain Rate Zone
Carrier			
Data Rate	(Mbps)	3.110	3.110
Modulation		QPSK	QPSK
FEC		0.691	0.691
Bandwidth	(dB-Hz)	64.3	64.3
Uplink			
Uplink Frequency	(MHz)	29,872	29,872
Tx E/S Antenna Diameter	(m)	0.65	0.65
Tx E/S Power to Antenna	(dBW)	4.0	4.0
Input Power Density	(dBW/Hz)	-60.3	-60.3
Tx E/S Antenna Gain	(dB)	43.2	43.2
Tx E/S EIRP per Carrier	(dBW)	47.2	47.2
Mispointing Error	(dB)	0.3	0.3
Atmospheric Losses	(dB)	0.5	0.5
Free Space Loss	(dB)	213.7	213.7
Satellite Antenna Gain (-3dB)	(dBi)	52.2	52.2
Satellite Antenna G/T (-3 dB)	(dB/K)	23.5	23.5
(C/I) Up - Intra-system	(dB)	23.0	23.0
Downlink			
Downlink Frequency	(MHz)	18,522	18,522
Downlink EIRP (-3 dB)	(dBW)	35.8	29.8
Beam Peak EIRP Density	(dBW/Hz)	-25.5	-31.5
Atmospheric Losses	(dB)	0.3	0.3
Free Space Loss	(dB)	209.5	209.5
Rx E/S Antenna Diameter	(m)	8.10	8.10
Antenna Mispointing Error	(dB)	0.50	0.50
Rx E/S Antenna Gain	(dB)	61.4	61.4
Rx E/S G/T	(dB/K)	37.7	37.7
System Noise Temp.	(K)	232	232
(C/I) Dn - Intra-system	(dB)	20.0	20.0
End-to-End			
(C/N) - Thermal Uplink	(dB)	20.5	20.5
(C/N) - Thermal Downlink	(dB)	27.5	21.5
(C/I) Up - ASI	(dB)	16.2	16.2
(C/I) Dn - ASI	(dB)	31.6	25.6
(C/N+I) - Total Actual	(dB)	13.0	12.4
(C/N+I) - Total Required	(dB)	5.1	5.1
System Margin	(dB)	7.9	7.3

Link Parameters	Clear Sky
Carrier	
Data Rate (Mbps)	69.100
Modulation	QPSK
FEC	0.691
Bandwidth (dB-Hz)	77.8
Uplink	
Uplink Frequency (MHz)	29,655
Tx E/S Antenna Diameter (m)	8.10
Tx E/S Power to Antenna (dBW)	7.4
Input Power Density (dBW/Hz)	-70.4
Tx E/S Antenna Gain (dB)	62.9
Tx E/S EIRP per Carrier (dBW)	70.3
Mispointing Error (dB)	0.5
Atmospheric Losses (dB)	0.5
Free Space Loss (dB)	213.6
Satellite Antenna Gain (-3dB) (dBi)	52.2
Satellite Antenna G/T (-3 dB) (dB/K)	23.5
(C/I) Up - Intra-system (dB)	24.0
Downlink	
Downlink Frequency (MHz)	18,716
Downlink EIRP (-3 dB) (dBW)	58.8
Beam Peak EIRP Density (dBW/Hz)	-16.0
Atmospheric Losses (dB)	0.3
Free Space Loss (dB)	209.6
Rx E/S Antenna Diameter (m)	0.65
Antenna Mispointing Error (dB)	0.30
Rx E/S Antenna Gain (dB)	40.3
Rx E/S G/T (dB/K)	19.1
System Noise Temp. (K)	132
(C/I) Dn - Intra-system (dB)	19.0
End-to-End	
(C/N) - Thermal Uplink (dB)	30.0
(C/N) - Thermal Downlink (dB)	18.5
(C/I) Up - ASI (dB)	25.7
(C/I) Dn - ASI (dB)	20.1
(C/N+I) - Total Actual (dB)	13.6
(C/N+I) - Total Required (dB)	5.1
System Margin (dB)	8.5

Link Parameters	Clear Sky High Downlink EIRP High Rain Rate Zone	Clear Sky Low Downlink EIRP Low Rain Rate Zone
Carrier		
Data Rate (Mbps)	42	42
Modulation	QPSK	QPSK
FEC	0.691	0.691
Bandwidth (dB-Hz)	75.6	75.6
Uplink		
Uplink Frequency (MHz)	29,406	29,406
Tx E/S Antenna Diameter (m)	8.10	8.10
Tx E/S Power to Antenna (dBW)	5.0	5.0
Input Power Density (dBW/Hz)	-70.6	-70.6
Tx E/S Antenna Gain (dB)	62.9	62.9
Tx E/S EIRP per Carrier (dBW)	67.9	67.9
Mispointing Error (dB)	0.5	0.5
Atmospheric Losses (dB)	0.5	0.5
Free Space Loss (dB)	213.5	213.5
Satellite Antenna Gain (-3dB) (dBi)	52.2	52.2
Satellite Antenna G/T (-3 dB) (dB/K)	23.5	23.5
(C/I) Up - Intra-system (dB)	21.0	21.0
Downlink		
Downlink Frequency (MHz)	19,851	19,851
Downlink EIRP (-3 dB) (dBW)	56.6	50.6
Beam Peak EIRP Density (dBW/Hz)	-16.0	-22.0
Atmospheric Losses (dB)	0.3	0.3
Free Space Loss (dB)	210.1	210.1
Rx E/S Antenna Diameter (m)	0.65	0.65
Antenna Mispointing Error (dB)	0.30	0.30
Rx E/S Antenna Gain (dB)	40.3	40.3
Rx E/S G/T (dB/K)	19.1	19.1
System Noise Temp. (K)	132	132
(C/I) Dn - Intra-system (dB)	19.0	19.0
End-to-End		
(C/N) - Thermal Uplink (dB)	29.9	29.9
(C/N) - Thermal Downlink (dB)	18.0	12.0
(C/I) Up - ASI (dB)	25.6	25.6
(C/I) Dn - ASI (dB)	16.6	10.6
(C/N+I) - Total Actual (dB)	12.1	7.6
(C/N+I) - Total Required (dB)	5.1	5.1
System Margin (dB)	7.0	2.5

Link Parameters	Clear Sky
Carrier	
Data Rate (Mbps)	53.264
Modulation	QPSK
FEC	0.691
Bandwidth (dB-Hz)	76.7
Uplink	
Uplink Frequency (MHz)	28,444
Tx E/S Antenna Diameter (m)	8.10
Tx E/S Power to Antenna (dBW)	5.0
Input Power Density (dBW/Hz)	-71.7
Tx E/S Antenna Gain (dB)	62.9
Tx E/S EIRP per Carrier (dBW)	67.9
Mispointing Error (dB)	0.5
Atmospheric Losses (dB)	0.5
Free Space Loss (dB)	213.2
Satellite Antenna Gain (-3dB) (dBi)	52.2
Satellite Antenna G/T (-3 dB) (dB/K)	23.5
(C/I) Up - Intra-system (dB)	32.0
Downlink	
Downlink Frequency (MHz)	20,074
Downlink EIRP (-3 dB) (dBW)	57.7
Beam Peak EIRP Density (dBW/Hz)	-16.0
Atmospheric Losses (dB)	0.3
Free Space Loss (dB)	210.2
Rx E/S Antenna Diameter (m)	0.65
Antenna Mispointing Error (dB)	0.30
Rx E/S Antenna Gain (dB)	40.3
Rx E/S G/T (dB/K)	19.1
System Noise Temp. (K)	132
(C/I) Dn - Intra-system (dB)	28.2
End-to-End	
(C/N) - Thermal Uplink (dB)	29.1
(C/N) - Thermal Downlink (dB)	17.9
(C/I) Up - ASI (dB)	24.8
(C/I) Dn - ASI (dB)	16.5
(C/N+I) - Total Actual (dB)	13.5
(C/N+I) - Total Required (dB)	5.1
System Margin (dB)	8.4

Command Link Budget (Transfer and Emergency)			
Link Parameters		Nom. U/L	Low U/L
Frequency	(MHz)	5,926.5	5,926.5
Incident Flux Density	(dBW/m ²)	-85.0	-90.0
Aperture Factor	(dB-m ²)	-36.9	-36.9
Incident Isotropic Power	(dBW)	-121.9	-126.9
Antenna Gain	(dBi)	-4.0	-4.0
Noise Temperature	(dB-K)	30.0	30.0
Satellite G/T	(dB/K)	-34.0	-34.0
Receive Losses	(dB)	-8.5	-8.5
Receiver Input Power	(dBm)	-104.4	-109.4
Receiver Threshold	(dBm)	-112.0	-112.0
Spacecraft Margin	(dB)	7.6	2.6

Command Link Budget (On-Station)			
Link Parameters		Nom. U/L	Low U/L
Frequency	(MHz)	29,999.5	29,999.5
Incident Flux Density	(dBW/m ²)	-110.0	-120.0
Aperture Factor	(dB-m ²)	-51.0	-51.0
Incident Isotropic Power	(dBW)	-161.0	-171.0
Antenna Gain (Peak)	(dBi)	55.2	55.2
Noise Temperature	(dB-K)	28.7	28.7
Satellite G/T	(dB/K)	26.5	26.5
Receive Losses	(dB)	-23.6	-23.6
Receiver Input Power	(dBm)	-99.4	-109.4
Receiver Threshold	(dBm)	-112.0	-112.0
Spacecraft Margin	(dB)	12.6	2.6

Telemetry Link Budget (Transfer and Emergency)		
Link Parameters		
Frequency	(MHz)	3,701
Transmit Power	(dBW)	15.7
Line Losses	(dB)	3.6
Antenna Gain, EOC	(dBi)	-4.0
EIRP	(dBW)	8.1
Free Space path Loss	(dB)	195.5
Rx E/S G/T	(dB/K)	24.5
Downlink C/N	(dB)	13.7
C/N Required	(dB)	9.0
Margin	(dB)	4.7

Telemetry Link Budget (On-Station)		
Link Parameters		
Frequency	(MHz)	20,198
Transmit Power	(dBW)	-5.0
Line Losses	(dB)	2.8
Antenna Gain, EOC	(dBi)	25.0
EIRP	(dBW)	17.2
Free Space path Loss	(dB)	210.4
Rx E/S G/T	(dB/K)	37.7
Downlink C/N	(dB)	21.1
C/N Required	(dB)	10.4
Margin	(dB)	10.7

S1. GENERAL INFORMATION Complete for all satellite applications.

a. Space Station or Satellite Network Name: SKYTERRA-1		e. Estimated Date of Placement into Service:		i. Will the space station(s) operate on a Common Carrier Basis: N
b. Construction Commencement Date:		f. Estimated Lifetime of Satellite(s): 12 Years		j. Number of transponders offered on a common carrier basis: 0
c. Construction Completion Date:		g. Total Number of Transponders: 131		k. Total Common Carrier Transponder Bandwidth: 0 MHz
d1. Est Launch Date Begin:	d2. Est Launch Date End:	h. Total Transponder Bandwidth (no. transponders x Bandwidth) 9836 MHz		l. Orbit Type: Mark all boxes that apply: <input checked="" type="checkbox"/> GSO <input type="checkbox"/> NGSO

S2. OPERATING FREQUENCY BANDS Identify the frequency range and transmit/receive mode for all frequency bands in which this station will oper
Also indicate the nature of service(s) for each frequency band.

Frequency Band Limits				e. T/R Mode	f. Nature of Service(s): List all that apply to this band
Lower Frequency (Hz)		Upper Frequency (Hz)			
a. Numeric	b. Unit (K/M/G)	c. Numeric	d. Unit (K/M/G)		
18.3	G	18.8	G	T	Fixed Satellite Service
19.7	G	20.2	G	T	Fixed Satellite Service
28.35	G	28.6	G	R	Fixed Satellite Service
29.25	G	30	G	R	Fixed Satellite Service
5926.25	M	5926.75	M	R	Fixed Satellite Service
6424.25	M	6424.75	M	R	Fixed Satellite Service
3700.75	M	3701.25	M	T	Fixed Satellite Service
4198.75	M	4199.25	M	T	Fixed Satellite Service

S3. ORBITAL INFORMATION FOR GEOSTATIONARY SATELLITES ONLY:

a. Nominal Orbital Longitude (Degrees E/W): 95 W		b. Alternate Orbital Longitude (Degrees E/W):		c. Reason for orbital location selection: Spectrum availability and look angle performance across service area.	
Longitudinal Tolerance or E/W Station-Keeping:		f. Inclination Excursion or N/S Station-Keeping Tolerance:		Range of orbital are in which adequate service can be provided (Optional): Degrees E/W	
d. Toward West:	0.05 Degrees	0.05 Degrees		g. Westernmost:	
e. Toward East:	0.05 Degrees			h. Easternmost:	
i. Reason for service are selection (Optional):					

**FEDERAL COMMUNICATIONS COMMISSION
 SATELLITE SPACE STATION AUTHORIZATIONS
 FCC Form 312 - Schedule S: (Technical and Operational Description)**

S4. ORBITAL INFORMATION FOR NON-GEOSTATIONARY SATELLITES ONLY

S4a. Total Number of Satellites in Network or System:

S4c. Celestial Reference Body (Earth, Sun, Moon, etc.):

S4b. Total Number of Orbital Planes in Network or System:

S4d. Orbit Epoch Date:

For each Orbital Plane Provide:

(e) Orbital Plane No.	(f) No. of Satellites in Plane	(g) Inclination Angle (degrees)	(h) Orbital Period (Seconds)	(i) Apogee (km)	(j) Perigee (km)	(k) Right Ascension of the Ascending Node (Deg.)	(l) Argument of Perigee (Degrees)	Active Service Arc Range (Degrees)		
								(m) Begin Angle	(n) End Angle	(o) Other

S5. INITIAL SATELLITE PHASE ANGLE For each satellite in each orbital plane, provide the initial phase angle.

(a) Orbital Plane No.	(b) Satellite Number	(c) Initial Phase Angle (Degrees)

NO NGSO DATA FILED

**FEDERAL COMMUNICATIONS COMMISSION
SATELLITE SPACE STATION AUTHORIZATIONS
FCC Form 312 - Schedule S: (Technical and Operational Description)**

S6. SERVICE AREA CHARACTERISTICS for each service area provide:

(a) Service Area ID	(b) Type of Associated Station (Earth or Space)	(c) Service Area Diagram File Name (GXT File)	(d) Service Area Description. Provide list of geographic areas (state postal codes or ITU 3-itr codes), satellites or Figure No. of Service Area Diagram.
CONUS	S		Continental United States

**FEDERAL COMMUNICATIONS COMMISSION
SATELLITE SPACE STATION AUTHORIZATIONS
FCC Form 312 - Schedule S: (Technical and Operational Description)**

S7. SPACE STATION ANTENNA BEAM CHARACTERISTICS For each antenna beam provide:

(a) Beam ID	(b) T/R Mode	Isotropic Antenna Gain		(e) Pointing Error (Degrees)	(f) Rotational Error (Degrees)	(g) Min. Cross- Polar Iso- lation (dB)	(h) Polar- ization Switch- able? (Y/N)	(i) Polarization Alignment Rel. Equatorial Plane (Degrees)	(j) Service Area ID	Transmit			Receive				
										(k) Input Losses (dB)	(l) Effective Output Power (W)	(m) Max. EIRP (dBW)	(n) System Noise Temp (k)	(o) G/T Max. Gain Pt. (db/K)	(p) Min. Saturation Flux Density (dBW/m2)	Input Attenuator (dB)	
		(q) Max. Value	(r) Step Size														
SPU2	R	55.2	51.2	0.03	0.01	30	N		CONUS				741	26.5	-81.6	15	1
SPU3	R	55.2	51.2	0.03	0.01	30	N		CONUS				741	26.5	-81.6	15	1
SPU5	R	55.2	51.2	0.03	0.01	30	N		CONUS				741	26.5	-81.6	15	1
SPU6	R	55.2	51.2	0.03	0.01	30	N		CONUS				741	26.5	-81.6	15	1
SPU1	R	55.2	51.2	0.03	0.01	30	N		CONUS				741	26.5	-81.6	15	1
SPU1	R	55.2	51.2	0.03	0.01	30	N		CONUS				741	26.5	-81.6	15	1
SPU1	R	55.2	51.2	0.03	0.01	30	N		CONUS				741	26.5	-81.6	15	1
SPU1	R	55.2	51.2	0.03	0.01	30	N		CONUS				741	26.5	-81.6	15	1
SPU1	R	55.2	51.2	0.03	0.01	30	N		CONUS				741	26.5	-81.6	15	1
SPU1	R	55.2	51.2	0.03	0.01	30	N		CONUS				741	26.5	-81.6	15	1
SPU1	R	55.2	51.2	0.03	0.01	30	N		CONUS				741	26.5	-81.6	15	1
SPU1	R	55.2	51.2	0.03	0.01	30	N		CONUS				741	26.5	-81.6	15	1
SPU1	R	55.2	51.2	0.03	0.01	30	N		CONUS				741	26.5	-81.6	15	1
SPU2	R	55.2	51.2	0.03	0.01	30	N		CONUS				741	26.5	-81.6	15	1
SPU2	R	55.2	51.2	0.03	0.01	30	N		CONUS				741	26.5	-81.6	15	1
SPU2	R	55.2	51.2	0.03	0.01	30	N		CONUS				741	26.5	-81.6	15	1
SPU2	R	55.2	51.2	0.03	0.01	30	N		CONUS				741	26.5	-81.6	15	1
SPU2	R	55.2	51.2	0.03	0.01	30	N		CONUS				741	26.5	-81.6	15	1
SPU2	R	55.2	51.2	0.03	0.01	30	N		CONUS				741	26.5	-81.6	15	1
SPU3	R	55.2	51.2	0.03	0.01	30	N		CONUS				741	26.5	-81.6	15	1
SPU3	R	55.2	51.2	0.03	0.01	30	N		CONUS				741	26.5	-81.6	15	1
SPU3	R	55.2	51.2	0.03	0.01	30	N		CONUS				741	26.5	-81.6	15	1
SPU3	R	55.2	51.2	0.03	0.01	30	N		CONUS				741	26.5	-81.6	15	1
SPU4	R	55.2	51.2	0.03	0.01	30	N		CONUS				741	26.5	-81.6	15	1
RU1	R	46.1	42.1	0.11	0.01	30	N		CONUS				826	16.9	-81.6	15	1
RU3	R	46.1	42.1	0.11	0.01	30	N		CONUS				826	16.9	-81.6	15	1
RU5	R	46.1	42.1	0.11	0.01	30	N		CONUS				826	16.9	-81.6	15	1
RU7	R	46.1	42.1	0.11	0.01	30	N		CONUS				826	16.9	-81.6	15	1
RU9	R	46.1	42.1	0.11	0.01	30	N		CONUS				826	16.9	-81.6	15	1
RU10	R	46.1	42.1	0.11	0.01	30	N		CONUS				826	16.9	-81.6	15	1
RU12	R	46.1	42.1	0.11	0.01	30	N		CONUS				826	16.9	-81.6	15	1
RU14	R	46.1	42.1	0.11	0.01	30	N		CONUS				826	16.9	-81.6	15	1

RU16	R	46.1	42.1	0.11	0.01	30	N		CONUS				826	16.9	-81.6	15	1
RU18	R	46.1	42.1	0.11	0.01	30	N		CONUS				826	16.9	-81.6	15	1
RU20	R	46.1	42.1	0.11	0.01	30	N		CONUS				826	16.9	-81.6	15	1
RU22	R	46.1	42.1	0.11	0.01	30	N		CONUS				826	16.9	-81.6	15	1
RU24	R	46.1	42.1	0.11	0.01	30	N		CONUS				826	16.9	-81.6	15	1
RU26	R	46.1	42.1	0.11	0.01	30	N		CONUS				826	16.9	-81.6	15	1
RU27	R	46.1	42.1	0.11	0.01	30	N		CONUS				826	16.9	-81.6	15	1
RU29	R	46.1	42.1	0.11	0.01	30	N		CONUS				826	16.9	-81.6	15	1
RU31	R	46.1	42.1	0.11	0.01	30	N		CONUS				826	16.9	-81.6	15	1
SPD2	T	52.2	48.2	0.03	0.01	30	N		CONUS	2.5	14.06	63.68					
SPD3	T	52.2	48.2	0.03	0.01	30	N		CONUS	2.5	44.99	68.73					
SPD5	T	52.2	48.2	0.03	0.01	30	N		CONUS	2.5	36.55	67.83					
SPD6	T	52.2	48.2	0.03	0.01	30	N		CONUS	2.5	44.99	68.73					
SPD1	T	52.2	48.2	0.03	0.01	30	N		CONUS	2.5	56.23	69.7					
SPD1	T	52.2	48.2	0.03	0.01	30	N		CONUS	2.5	56.23	69.7					
SPD1	T	52.2	48.2	0.03	0.01	30	N		CONUS	2.5	36.55	67.83					
SPD1	T	52.2	48.2	0.03	0.01	30	N		CONUS	2.5	36.55	67.83					
SPD1	T	52.2	48.2	0.03	0.01	30	N		CONUS	2.5	22.49	65.72					
SPD1	T	52.2	48.2	0.03	0.01	30	N		CONUS	2.5	22.49	65.72					
SPD1	T	52.2	48.2	0.03	0.01	30	N		CONUS	2.5	56.23	69.7					
SPD2	T	52.2	48.2	0.03	0.01	30	N		CONUS	2.5	36.55	67.83					
SPD2	T	52.2	48.2	0.03	0.01	30	N		CONUS	2.5	22.49	65.72					
SPD2	T	52.2	48.2	0.03	0.01	30	N		CONUS	2.5	56.23	69.7					
SPD2	T	52.2	48.2	0.03	0.01	30	N		CONUS	2.5	22.49	65.72					
SPD2	T	52.2	48.2	0.03	0.01	30	N		CONUS	2.5	36.55	67.83					
SPD3	T	52.2	48.2	0.03	0.01	30	N		CONUS	2.5	56.23	69.7					
SPD3	T	52.2	48.2	0.03	0.01	30	N		CONUS	2.5	56.23	69.7					
SPD3	T	52.2	48.2	0.03	0.01	30	N		CONUS	2.5	22.49	65.72					
SPD3	T	52.2	48.2	0.03	0.01	30	N		CONUS	2.5	22.49	65.72					
SPD4	T	52.2	48.2	0.03	0.01	30	N		CONUS	2.5	56.23	69.7					
RD1	T	46.1	42.1	0.11	0.01	30	N		CONUS	2.1	37	61.8					
RD3	T	46.1	42.1	0.11	0.01	30	N		CONUS	2.1	37	61.8					
RD5	T	46.1	42.1	0.11	0.01	30	N		CONUS	2.1	37	61.8					
RD7	T	46.1	42.1	0.11	0.01	30	N		CONUS	2.1	37	61.8					
RD9	T	46.1	42.1	0.11	0.01	30	N		CONUS	2.1	37	61.8					
RD10	T	46.1	42.1	0.11	0.01	30	N		CONUS	2.1	37	61.8					
RD12	T	46.1	42.1	0.11	0.01	30	N		CONUS	2.1	37	61.8					
RD14	T	46.1	42.1	0.11	0.01	30	N		CONUS	2.1	37	61.8					
RD16	T	46.1	42.1	0.11	0.01	30	N		CONUS	2.1	37	61.8					

RD18	T	46.1	42.1	0.11	0.01	30	N		CONUS	2.1	37	61.8					
RD20	T	46.1	42.1	0.11	0.01	30	N		CONUS	2.1	37	61.8					
RD22	T	46.1	42.1	0.11	0.01	30	N		CONUS	2.1	37	61.8					
RD24	T	46.1	42.1	0.11	0.01	30	N		CONUS	2.1	37	61.8					
RD26	T	46.1	42.1	0.11	0.01	30	N		CONUS	2.1	37	61.8					
RD27	T	46.1	42.1	0.11	0.01	30	N		CONUS	2.1	37	61.8					
RD29	T	46.1	42.1	0.11	0.01	30	N		CONUS	2.1	37	61.8					
RD31	T	46.1	42.1	0.11	0.01	30	N		CONUS	2.1	37	61.8					
CON	T	36	26	0.11	0.01	30	N		CONUS	2.5	292.4	60.66					
CON	T	36	26	0.11	0.01	30	N		CONUS	2.5	292.4	60.66					
OMN	T	0	-4	0.11	0.01	30	N	0	CONUS	3.6	16.2	12.1					
TLML	T	28	25	0.11	0.01	30	N		CONUS	2.8	0.166	20.2					
OMN	R	0	-4	0.11	0.01	30	N	0	CONUS				1000	-30			
OMN	T	0	-4	0.11	0.01	30	N	90	CONUS	3.6	16.2	12.1					
OMN	R	0	-4	0.11	0.01	30	N	90	CONUS				1000	-30			

**FEDERAL COMMUNICATIONS COMMISSION
SATELLITE SPACE STATION AUTHORIZATIONS
FCC Form 312 - Schedule S: (Technical and Operational Description)**

S8. ANTENNA BEAM DIAGRAMS For each beam pattern provide the reference to the graphic image and numerical data:
Also provide the power flux density levels in each beam that result from the emission with the highest power flux density.

(a) Beam ID	(b) T/R Mode	(c) Co-or Cross Polar Mode ("C" or "X")	(d) GSO Ref. Orbital Longitude (Deg. E/W)	(e) NGSO Antenna Gain Contour Description (Figure/Table/ Exhibit)	(f) GSO Antenna Gain Contour Data (GXT File)	Max. Power Flux Density (dBW/M2/Hz)				
						At Angle of Arrival above horizontal (for emission with highest PFD)				
						(g) 5 Deg	(h) 10 Deg	(i) 15 Deg	(j) 20 Deg	(k) 25 Deg
CON	T	C	-95		CONL.gxt	-118	-118	-118	-118	-118
CON	T	C	-95		CONR.gxt	-118	-118	-118	-118	-118
TLML	T	C	-95		TLML.gxt	-134.4	-134.4	-134.4	-134.4	-134.4
CON	T	C	-95		CONL.gxt	-118	-118	-118	-118	-118
CON	T	C	-95		CONR.gxt	-118	-118	-118	-118	-118
TLML	T	C	-95		TLML.gxt	-134.4	-134.4	-134.4	-134.4	-134.4

**FEDERAL COMMUNICATIONS COMMISSION
SATELLITE SPACE STATION AUTHORIZATIONS
FCC Form 312 - Schedule S: (Technical and Operational Description)**

S9. SPACE STATION CHANNELS For each frequency channel provide:

S10. SPACE STATION TRANSPONDERS For each transponder provide:

(a) Channel No.	(b) Assigned Bandwidth (kHz)	(c) T/R Mode	(d) Center Frequency (MHz)	(e) Polarization (H, V, L, R)	(f) TTC or Comm Channel (T or C)
U1	85000	R	29872.5	R	C
D1	85000	T	18522.5	L	C
U2	10500	R	29795	L	C
D2	10500	T	18445	L	C
U3	10500	R	29774	L	C
D3	10500	T	18424	L	C
U4	10500	R	29754	L	C
D4	10500	T	18404	L	C
U5	10500	R	29733	L	C
D5	10500	T	18383	L	C
U6	60000	R	29655	R	C
D6	60000	T	18662	R	C
D7	60000	T	18770	R	C
U7	292000	R	29406	R	C
D8	292000	T	19851	L	C
U8	46250	R	28398.125	R	C
U9	46250	R	28444.375	R	C
U10	46250	R	28490.625	R	C
U11	46250	R	28536.875	R	C
D9	46250	T	20028.125	R	C
D10	46250	T	20074.375	L	C
D11	46250	T	20120.625	R	C
D12	46250	T	20166.875	L	C
C1	500	R	5926.5	H	T
C2	500	R	6424.5	V	T
C3	500	R	29999.5	R	T
T1	500	T	3701	H	T
T2	500	T	4199	V	T
T3	500	T	20198	L	T

(a) Transponder ID	(b) Transponder Gain (dB)	Receive Band		Transmit Band	
		(c) Channel No.	(d) Beam ID	(e) Channel No.	(f) Beam ID
SR1	88.9	U1	SPU2	D1	SPD2
SR2	93.9	U1	SPU3	D1	SPD3
SR3	93	U1	SPU5	D1	SPD5
SR4	93.9	U1	SPU6	D1	SPD6
SR5	94.9	U1	SPU10	D1	SPD10
SR6	94.9	U1	SPU11	D1	SPD11
SR7	93	U1	SPU13	D1	SPD13
SR8	93	U1	SPU14	D1	SPD14
SR9	90.9	U1	SPU16	D1	SPD16
SR10	90.9	U1	SPU18	D1	SPD18
SR11	94.9	U1	SPU19	D1	SPD19
SR12	93	U1	SPU21	D1	SPD21
SR13	90.9	U1	SPU22	D1	SPD22
SR14	94.9	U1	SPU23	D1	SPD23
SR15	90.9	U1	SPU25	D1	SPD25
SR16	93	U1	SPU27	D1	SPD27
SR17	94.9	U1	SPU31	D1	SPD31
SR18	94.9	U1	SPU34	D1	SPD34
SR19	90.9	U1	SPU35	D1	SPD35
SR20	90.9	U1	SPU36	D1	SPD36
SR21	94.9	U1	SPU41	D1	SPD41
RR1	88.9	U2	RU10	D2	SPD2
RR2	93.9	U2	RU18	D2	SPD3
RR3	93	U2	RU16	D2	SPD5
RR4	93.9	U2	RU9	D2	SPD6
RR5	94.9	U2	RU29	D2	SPD10
RR6	93	U2	RU5	D2	SPD13
RR7	93	U2	RU7	D2	SPD14
RR8	90.9	U2	RU3	D2	SPD16
RR9	90.9	U2	RU20	D2	SPD18

RR10	94.9	U2	RU31	D2	SPD19
RR11	93	U2	RU14	D2	SPD21
RR12	90.9	U2	RU1	D2	SPD22
RR13	90.9	U2	RU12	D2	SPD25
RR14	93	U2	RU22	D2	SPD27
RR15	94.9	U2	RU26	D2	SPD34
RR16	90.9	U2	RU27	D2	SPD35
RR17	94.9	U2	RU24	D2	SPD41
RR18	88.9	U3	RU10	D3	SPD2
RR19	93.9	U3	RU18	D3	SPD3
RR20	93	U3	RU16	D3	SPD5
RR21	93.9	U3	RU9	D3	SPD6
RR22	94.9	U3	RU29	D3	SPD10
RR23	93	U3	RU5	D3	SPD13
RR24	93	U3	RU7	D3	SPD14
RR25	90.9	U3	RU3	D3	SPD16
RR26	90.9	U3	RU20	D3	SPD18
RR27	94.9	U3	RU31	D3	SPD19
RR28	93	U3	RU14	D3	SPD21
RR29	90.9	U3	RU1	D3	SPD22
RR30	90.9	U3	RU12	D3	SPD25
RR31	93	U3	RU22	D3	SPD27
RR32	94.9	U3	RU26	D3	SPD34
RR33	90.9	U3	RU27	D3	SPD35
RR34	94.9	U3	RU24	D3	SPD41
RR35	88.9	U4	RU10	D4	SPD2
RR36	93.9	U4	RU18	D4	SPD3
RR37	93	U4	RU16	D4	SPD5
RR38	93.9	U4	RU9	D4	SPD6
RR39	94.9	U4	RU29	D4	SPD10
RR40	93	U4	RU5	D4	SPD13
RR41	93	U4	RU7	D4	SPD14
RR42	90.9	U4	RU3	D4	SPD16
RR43	90.9	U4	RU20	D4	SPD18
RR44	94.9	U4	RU31	D4	SPD19
RR45	93	U4	RU14	D4	SPD21
RR46	90.9	U4	RU1	D4	SPD22
RR47	90.9	U4	RU12	D4	SPD25
RR48	93	U4	RU22	D4	SPD27

RR49	94.9	U4	RU26	D4	SPD34
RR50	90.9	U4	RU27	D4	SPD35
RR51	94.9	U4	RU24	D4	SPD41
RR52	88.9	U5	RU10	D5	SPD2
RR53	93.9	U5	RU18	D5	SPD3
RR54	93	U5	RU16	D5	SPD5
RR55	93.9	U5	RU9	D5	SPD6
RR56	94.9	U5	RU29	D5	SPD10
RR57	93	U5	RU5	D5	SPD13
RR58	93	U5	RU7	D5	SPD14
RR59	90.9	U5	RU3	D5	SPD16
RR60	90.9	U5	RU20	D5	SPD18
RR61	94.9	U5	RU31	D5	SPD19
RR62	93	U5	RU14	D5	SPD21
RR63	90.9	U5	RU1	D5	SPD22
RR64	90.9	U5	RU12	D5	SPD25
RR65	93	U5	RU22	D5	SPD27
RR66	94.9	U5	RU26	D5	SPD34
RR67	90.9	U5	RU27	D5	SPD35
RR68	94.9	U5	RU24	D5	SPD41
RF1	111.7	U6	SPU2	D6	RD10
RF2	111.7	U6	SPU3	D6	RD18
RF3	111.7	U6	SPU5	D6	RD16
RF4	111.7	U6	SPU6	D7	RD9
RF5	111.7	U6	SPU10	D6	RD29
RF6	111.7	U6	SPU13	D7	RD5
RF7	111.7	U6	SPU14	D7	RD7
RF8	111.7	U6	SPU16	D7	RD3
RF9	111.7	U6	SPU18	D7	RD20
RF10	111.7	U6	SPU19	D6	RD31
RF11	111.7	U6	SPU21	D6	RD14
RF12	111.7	U6	SPU22	D7	RD1
RF13	111.7	U6	SPU25	D6	RD12
RF14	111.7	U6	SPU27	D7	RD22
RF15	111.7	U6	SPU34	D7	RD26
RF16	111.7	U6	SPU35	D6	RD27
RF17	111.7	U6	SPU41	D7	RD24
SF1	88.9	U7	SPU2	D8	SPD2
SF2	93.9	U7	SPU3	D8	SPD3

SF3	93	U7	SPU5	D8	SPD5
SF4	93.9	U7	SPU6	D8	SPD6
SF5	94.9	U7	SPU10	D8	SPD10
SF6	94.9	U7	SPU11	D8	SPD11
SF7	93	U7	SPU13	D8	SPD13
SF8	93	U7	SPU14	D8	SPD14
SF9	90.9	U7	SPU16	D8	SPD16
SF10	90.9	U7	SPU18	D8	SPD18
SF11	94.9	U7	SPU19	D8	SPD19
SF12	93	U7	SPU21	D8	SPD21
SF13	90.9	U7	SPU22	D8	SPD22
SF14	94.9	U7	SPU23	D8	SPD23
SF15	90.9	U7	SPU25	D8	SPD25
SF16	93	U7	SPU27	D8	SPD27
SF17	94.9	U7	SPU31	D8	SPD31
SF18	94.9	U7	SPU34	D8	SPD34
SF19	90.9	U7	SPU35	D8	SPD35
SF20	90.9	U7	SPU36	D8	SPD36
SF21	94.9	U7	SPU41	D8	SPD41
CF1	121.8	U8	SPU2	D9	CONR
CF2	121.8	U9	SPU16	D10	CONL
CF3	121.8	U10	SPU18	D11	CONR
CF4	121.8	U11	SPU35	D12	CONL
C1		C1	OMNRH		
C2		C2	OMNRV		
C3		C3	SPU2		
T1				T1	OMNTH
T2				T2	OMNTV
T3				T3	TLML

FEDERAL COMMUNICATIONS COMMISSION
SATELLITE SPACE STATION AUTHORIZATIONS
FCC Form 312 - Schedule S: (Technical and Operational Description)

S11. DIGITAL MODULATION PARAMETERS For each digital emission provide:

(a) Digital Mod. ID	(b) Emission Designator	(c) Assigned Bandwidth (kHz)	(d) No. of Phases	(e) Uncoded Data Rate (kbps)	(f) FEC Error Correction Coding Rate	(g) CDMA Processing Gain (dB)	(h) Total C/N Performance Objective (dB)	(i) Single Entry C/I Objective (dB)
D1	2M70G7W	2700	4	2149	0.691		5.1	17.3
D2	248KG7W	248	4	197	0.691		5.1	17.3
D3	60M0G7W	60000	4	47748	0.691		5.1	17.3
D4	36M5G7W	36500	4	29022	0.691		5.1	17.3
D5	46M3G7W	46250	4	36805	0.691		5.1	17.3

FEDERAL COMMUNICATIONS COMMISSION
SATELLITE SPACE STATION AUTHORIZATIONS
FCC Form 312 - Schedule S: (Technical and Operational Description)

S13. TYPICAL EMISSIONS For each planned type of emission provide:

Associated Transponder ID Range		Modulation ID		(e) Carriers per Transponder	(f) Carrier Spacing (kHz)	(g) Noise Budget Reference (Table No.)	(h) Energy Dispersal Bandwidth (kHz)	Receive Band (Assoc. Transmit Stn)			Transmit Band (This Space Station)			
		(c) Digital (Table S11)	(d) Analog (Table S12)					(i) Assoc. Stn. Max. Antenna Gain (dBi)	Assoc. Station Transmit Power (dBW)		EIRP (dBW)		(n) Max. Power Flux Density (dBW/m ² /Hz)	(o) Assoc. Stn Rec. G/T (dB/K)
(a) Start	(b) End							(j) Min.	(k) Max.	(l) Min.	(m) Max.			
SR1	SR21	D1		31	2741.935	SR LB.doc		43.2	1	5	28.8	38.8	-127.6	37.7
RR1	RR68	D2		42	256	RR LB.doc		43.2	-6.5	-2.5	19.6	29.6	-126.5	37.7
RF1	RF17	D3		1		RF LB.doc		62.9	-1.1	8.4	57.8	61.8	-118	19.1
SF1	SF21	D4		8	36500	SF LB.doc		62.9	2	6	49.6	59.6	-118	19.1
CF1	CF4	D5		1		CF LB.doc		62.9	2	6	50.7	60.7	-118	19.1
C1	C2		A1	1		C1 LB.doc		53	20.3	25.3				
C3	C3		A3	1		Ka CMD LB.do		62.9	-20	-9				
T1	T2		A2	1		T1 LB.doc					8.1	12.1	-166	24.5
T3	T3		A4	1		Ka TLM LB.doc					17.2	20.2	-134	37.7

FEDERAL COMMUNICATIONS COMMISSION
SATELLITE SPACE STATION AUTHORIZATIONS
FCC Form 312 - Schedule S: (Technical and Operational Description)

S14. Is the space station(s) controlled and monitored remotely? If Yes, provide the location and telephone number of the TT and C control point(s): Yes

**FEDERAL COMMUNICATIONS COMMISSION
SATELLITE SPACE STATION AUTHORIZATIONS
FCC Form 312 - Schedule S: (Technical and Operational Description)**

Page 11:
Characteristics and
Certifications

S15. SPACECRAFT PHYSICAL CHARACTERISTICS:

S15a. Mass of spacecraft without fuel (kg): 2499	Spacecraft Dimensions (meters)	Probability of Survival to End of Life (0.0 - 1.0)
S15b. Mass of fuel and disposables at launch (kg): 3140		
S15c. Mass of spacecraft and fuel at launch (kg): 5639	S15f. Length (m): 24	S15i. Payload: 0.9
S15d. Mass of fuel, in orbit, at beginning of life (kg): 800	S15g. Width (m): 3	S15j. Bus: 0.89
S15e. Deployed Area of Solar Array (square meters): 60	S15h. Height (m): 3.6	S15k. Total: 0.8

S16. SPACECRAFT ELECTRICAL CHARACTERISTICS:

Spacecraft Subsystem	Electrical Power (Watts) At Beginning of Life		Electrical Power (Watts) At End of Life	
	At Equinox	At Solstice	At Equinox	At Solstice
Payload (Watts):	(a): 8403	(f): 8403	(k): 8403	(p): 8403
Bus (Watts):	(b): 2651	(g): 1409	(l): 2651	(q): 1409
Total (Watts):	(c): 11054	(h): 9812	(m): 11054	(r): 9812
Solar Array (Watts):	(d): 13951	(i): 11782	(n): 12434	(s): 10668
Depth of Battery Discharge (%):	(e) 76.8 %	(j) 76.8 %	(o) 76.8 %	(t) 76.8 %

S17. CERTIFICATIONS:

a. Are the power flux density limits of § 25.208 met?:	<input checked="" type="checkbox"/> YES	<input type="checkbox"/> NO	<input type="checkbox"/> N/A
b. Are the appropriate service area coverage requirements of § 25.143(b)(ii) and (iii), or § 25.145(c)(1) and (2) met?:	<input type="checkbox"/> YES	<input type="checkbox"/> NO	<input checked="" type="checkbox"/> N/A
c. Are the frequency tolerances of § 25.202(e) and the out-of-band emission limits of § 25.202(f)(1), (2) and (3) met?:	<input checked="" type="checkbox"/> YES	<input type="checkbox"/> NO	<input type="checkbox"/> N/A

In addition to the information required in this Form, the space station applicant is required to provide all the information specified in Section 25.114 of the Commission's rules, 47 C.F.R § 25.114.