

Rainbow DBS Company LLC Application for Authority to Construct, Launch and Operate a Ka-Band Communications Satellite System

This attachment contains the narrative to the application as required by 47 CFR § 25.114, the required certifications with electronic signatures (the actual signatures are on file with applicant's counsel), and the Technical Annex. Please contact Benjamin J. Griffin, Counsel to Rainbow DBS Company LLC, at 202.434.7300 if there are any questions concerning this application or the attachments

**Before the
FEDERAL COMMUNICATIONS COMMISSION
Washington, D.C. 20554**

In the Matter of the Application of)
)
Rainbow DBS Company LLC) File No. _____
)
For Authority to Construct, Launch and)
Operate a Ka-Band Communications)
Satellite System)
)

APPLICATION FOR AUTHORITY

Rainbow DBS Company LLC (“Rainbow DBS”),^{1/} pursuant to Sections 308, 309, and 319 of the Communications Act of 1934, as amended,^{2/} hereby requests authority to construct, launch, and operate a two-satellite geostationary (“GSO”) communications satellite system using the Ka-band frequencies specified herein (“Rainbow Ka System”).^{3/} One satellite – Rainbow Ka 4 – is to be located at 71° W.L., while the second satellite – Rainbow Ka 5 – is to be located at 119° W.L.

The narrative to this application demonstrates how the Rainbow Ka System will comply with Sections 25.114 and 25.140 of the Commission’s rules for Ka-band satellite systems and

^{1/} Rainbow DBS is an indirect wholly-owned subsidiary of Cablevision Systems Corporation (“Cablevision”).

^{2/} 47 U.S.C. §§ 308, 309, 319.

^{3/} The Commission’s rules permit an applicant proposing more than one space station to provide the required information in a consolidated system application. 47 CFR § 114(a). Simultaneous with the filing of this application, Rainbow DBS is submitting two other applications for Ka-band satellites to be located at 62° W.L., 87° W.L. and 129° W.L. The grant of any, or all, of these applications will enable Rainbow DBS to implement its objectives. The three applications, requesting five satellites, are within the five satellite per frequency limit placed on new applicants by the Commission’s rules. *See* 47 CFR § 25.159(a).

sets forth the legal, technical and financial qualifications of Rainbow DBS to hold a Commission license for a communications satellite system in the Ka-band.

The applicant's address and phone number is:

Rainbow DBS Company LLC ("Rainbow DBS")
200 Jericho Quadrangle
Jericho, New York 11753
516.803.2569

Correspondence with respect to this application should be sent to the following person at the above address and telephone number:

David Deitch
Senior Vice President and General Counsel

with a copy to:

Benjamin J. Griffin
Mintz, Levin, Cohn, Ferris, Glovsky & Popeo PC
701 Pennsylvania Avenue, NW
Washington, D.C 20004
202.434.7300

Through this application, Rainbow DBS seeks authority to construct, launch and operate a Ka-band geostationary communications satellite system using two satellites, one at the 71° W.L. orbital location, and the other at the 119° W.L. orbital location.^{4/} Rainbow recognizes coordination will be required with other Ka-band satellites authorized by the Commission as well as those of the U.S. government and other administrations.

The proposed service offerings would include, but not necessarily be limited to:

- Interactive data and video applications,

^{4/} Because the ITU database includes coordination documents previously submitted by the United States for use of the orbital locations and frequencies requested in this application, the need for additional ITU filings at this time is unclear. Nevertheless, Rainbow DBS accepts full responsibility for all necessary current and future ITU filing costs. In accordance with the Public Notice issued by the International Bureau on October 19, 2001, Rainbow DBS requests that the contact information is as follows: Mr. David Deitch, General Counsel and Senior Vice President, Rainbow DBS Company LLC 200 Jericho Quadrangle, Jericho, NY 11753, dadeitch@rainbow-media.com, (516) 803-2569, (516) 803-4824 (fax).

- Secure, streaming, switched video applications, and
- Broadband data services.

From these cited orbit locations, the Rainbow Ka System will be able to provide service in all 50 states of the U.S. as well as the southern tier of Canada and parts of Mexico.

I. LEGAL QUALIFICATIONS

There can be no doubt as to the legal qualifications of Rainbow DBS to be a Commission licensee. In fact, the Commission has just recently passed on the credentials of Rainbow DBS to be a Commission licensee in the Direct Broadcast Satellite service.^{5/} Additional documentation attesting to Rainbow DBS's legal qualifications is provided in the attached Form 312 and the attachment to question 40 on the Form 312, which documents the directors, officers and major shareholders of Rainbow DBS.

II. TECHNICAL QUALIFICATIONS

The Rainbow Ka System will deliver a wide array of advanced, bi-directional broadband digital services to consumers, business and government with point-to-point, point-to-multipoint, or multipoint-to-point connectivity. These will include such specific services as interactive video, secure streaming video, and bi-directional secure broadband data. The space segment of the Rainbow Ka System will consist of two multi-spot beam spacecraft in the GSO whose combined footprints will include all 50 states of the U.S. and parts of Canada and Mexico. The ground segment of the system will include gateway and user earth stations, a Network Operations Centers ("NOC"), and a Spacecraft Operations Center ("SOC"). The diameter of the antennas of the user and gateway earth stations will depend on link availability requirements, as

^{5/} See R/L DBS Company, LLC Application for Minor Modification to Direct Broadcast Satellite Authorization, for Issuance of Authority to Launch, and for Authority to Operate Rainbow 1 (USABBS-17), File No. SAT-MOD-20020408-00062, *Order and Authorization*, DA 03-115 (rel. April 22, 2003).

well as the rain history at the specific site and the distance of the station from the center of the spot beam.

Each of the satellites in the Rainbow Ka System will employ the 1 GHz of Ka-band spectrum already allocated by the Commission to the Fixed Satellite Service (“FSS”) operating in the GSO on a Primary or co-Primary basis. The Rainbow Ka System will use the Ka-band spectrum – 18.3-18.8 GHz; 19.7-20.2 GHz for space-to-Earth transmissions and 28.35-28.6 GHz; 29.25-30.0 GHz for Earth-to-space transmissions.

The Technical Annex to this application provides the required showings demonstrating the technical qualifications of Rainbow DBS as a Ka-band FSS licensee.

III. FINANCIAL QUALIFICATIONS

The financial qualification requirements of Section 25.114(c)(12) have been eliminated^{6/} and replaced with a requirement to post a bond 30 days after the award of a license.^{7/} Rainbow DBS recognizes the requirement that it post such a bond should it be awarded a license pursuant to this application.

IV. PUBLIC INTEREST CONSIDERATIONS

Rainbow DBS seeks to provide the public with a wide array of communications services that are currently unavailable or available on only a very limited basis. As such, several important public interest considerations support approval of Rainbow DBS’s application to construct, launch and operate Ka-band communications satellites in the FSS.

Through its proposed Ka-band service, Rainbow DBS seeks to provide broadband and interactive media services to residential and small, underserved business consumers. Such an

^{6/} Amendment of the Commission’s Space Station Licensing Rules and Policies, IB Docket No. 02-34, *First Report and Order and Further Notice of Proposed Rulemaking*, FCC 03-102, ¶ 164 (rel. May 19, 2003) (“*First Space Station Reform Order*”).

^{7/} *Id.* ¶ 168.

offering will add to the developing broadband market and provide consumers with a new, innovative offering in the nascent interactive digital video marketplace. Furthermore, Rainbow DBS, through its DBS service to be launched in October 2003, will facilitate the use of new consumer technologies. The launch of Rainbow DBS's Ka-band service will supplement and complement the DBS service, enabling consumers to more fully take advantage of the new services and technologies. By offering these new services using advanced consumer technology, Rainbow DBS will be fulfilling the statutory command to promote the development and rapid deployment of new technologies, products and services for the benefit of the public.^{8/}

By supplementing its DBS service with its Ka-band offering, Rainbow DBS also will enhance competition in the multichannel video program distribution ("MVPD") and DBS markets by strengthening the third entrant into the DBS market.^{9/} This will help fulfill the Commission's charge to promote competition and avoid the excessive concentration of licenses.^{10/}

V. NON-COMMON CARRIER BASIS

All transponders on the Rainbow Ka System will be operated on a non-common carrier basis. Any transponders or services made available by Rainbow DBS to third parties will be made available under individually negotiated, long-term private contracts with customers.

^{8/} 47 U.S.C. § 157 ("It shall be the policy of the United States to encourage the provision of new technologies and services to the public."); see also 47 U.S.C. § 309(j)(3)(A).

^{9/} See Petition of R/L DBS Company, L.L.C. for Extension of its Direct Broadcast Satellite Construction Permit, File No. DBS 87-01, *Memorandum Opinion and Order*, 16 FCC Rcd 9, 16 (2000) ("R[ainbow] may well be the last opportunity in the near-term for entry by a competitive provider within the DBS service itself").

^{10/} See 47 U.S.C. § 309(j)(3)(C).

VI. SYSTEM MILESTONE DATES

In the Commission's *First Space Station Reform Order*, generic milestone requirements were adopted for all satellite services.^{11/} Should Rainbow DBS acquire a license pursuant to this application, it intends to execute a binding contract for construction of its satellites within one year of receipt of its authorization, complete the Critical Design Review for the spacecraft within two years, commence construction within three years, and launch the satellites and begin operations within five years.

VII. WAIVER OF CLAIMS

Rainbow DBS waives any claim to the use of any particular frequency or of the electromagnetic spectrum as against the regulatory power of the United States because of previous use of the same, whether by license or otherwise, and requests construction, launch and operating authority in accordance with this application. All statements made in the attached certifications, applications and annex are a material part hereof, and are incorporated herein as if set out in full in this application.

VIII. ENGINEERING CERTIFICATION

A certification of the person responsible for preparation of the engineering information contained in this application is attached hereto.

IX. COMPLIANCE WITH PART 25 RULES

Below is a table detailing which sections of this application provide the information on the Rainbow Ka 4 and the Rainbow Ka 5 satellites as required by Sections 25.114 and 25.140 and other Commission rules for the fixed satellite service in the Ka-band.

^{11/} *First Space Station Reform Order* ¶¶ 174-75

Commission Requirements for Ka-Band Satellite Applicants

Rule	Requirement	Rainbow Ka System
25.114(a)	Filing of Form 312	Form 312 Attached.
25.114(b)	Formal waiver of Section 304 of the Communications Act	Application Narrative at 6.
25.114(c)(1)	Applicant name, address and telephone number	Application Narrative at 2.
25.114(c)(2)	Contact information	Application Narrative at 2.
25.114(c)(3)	Type of authorization requested	Application Narrative at 2.
25.114(c)(4)	General description of facilities, operations and services	Application Narrative at 2, 3; Technical Annex at § I.
25.114(c)(5)	RF plan, emission designators, beam connectivity, etc.	Technical Annex at §§ II.C and III.
25.114(c)(6)	Orbital location requested, alternatives and limits	Application Narrative at 2; Technical Annex at § II.A.
25.114(c)(7)	Satellite antenna contours	Technical Annex at § IV.
25.114(c)(8)	Service description, transmission characteristics, link budgets, earth station characteristics	Technical Annex at §§ IV, V, Appendix A.
25.114(c)(9)	Spacecraft/antenna pointing and station-keeping accuracies	Technical Annex at § IV.
25.114(c)(10)	PFD calculations	Technical Annex at § VI.A.
25.114(c)(11)	Arrangement for TT&C	Technical Annex at § IV.C.
25.114(c)(12)	Physical characteristics, mass and power budget, sat. reliability/life estimates	Technical Annex at § IV.
25.114(c)(13)	Financial qualifications	This showing has been replaced with a bond requirement, due after issuance of license. Application Narrative at 4.
25.114(c)(14)	Common Carrier Status	Application Narrative at 5.
25.114(c)(15)	Milestone dates for construction, launch, etc.	Application Narrative at 6.
25.114(c)(16)	Public Interest Considerations	Application Narrative at 4-5.
25.140(b)(1)	Legal Qualifications	Application Narrative at 3; Form 312, Question 40.
25.140(b)(2)	Interference analysis for 2° spacing	Technical Annex at § VI.

**CERTIFICATION OF PERSON RESPONSIBLE
FOR PREPARING ENGINEERING INFORMATION**

I hereby declare under penalty of perjury that I am the technically qualified person responsible for preparation of the information contained in the foregoing application, that I am familiar with Part 25 of the Commission's rules, that I have either prepared or reviewed the engineering information submitted in this application, and that it is complete and accurate to the best of my knowledge and belief.

_____/s/_____
Wilt Hildenbrand
Executive Vice President, Engineering & Technology
Cablevision Systems Corporation
1111 Stewart Avenue
Bethpage, New York 11714

Dated: August 26, 2003

TECHNICAL ANNEX

I. SYSTEM OVERVIEW

The space segment of the Rainbow Ka System will consist of two multi-spot beam spacecraft in the geostationary orbit (“GSO”) whose combined footprints will provide service in all 50 of the United States, as well as parts of Mexico and Canada.^{1/} The ground segment of the system will include gateway/hub and user/consumer earth stations, as well as Network Operations Centers (“NOCs”), and a Spacecraft Operations Center (“SOC”). The diameter of the antennas of the consumer/user and gateway/hub earth stations will depend on individual user link availability requirements, as well as the rain history at the specific site, the distance of the station from the center of the spot beam and the elevation angle of the earth station antenna to the serving satellite.

The Rainbow Ka System will deliver a wide array of advanced, bi-directional broadband digital services to consumers, business and government with point-to-point, point-to-multipoint, or multipoint-to-point connectivity. These will include such specific services as interactive video, secure streaming video, and bi-directional secure broadband data. The gateway/hub earth stations will be connected to appropriate terrestrially-based networks to ensure reliable, ubiquitous delivery. Network Operations Centers will be established, as necessary, to control traffic flow and user access to the system, as well as for billing and other customer service activities. The SOC will control and monitor the health and status of the space segment.

Each of the satellites in the Rainbow Ka System will employ one GHz of Ka-band spectrum in each direction already allocated by the Commission to the Fixed Satellite Service (“FSS”) for operations in the GSO on a Primary or co-Primary basis. Link availability levels of service to the users will be dependent not only on the reliability of the satellites and the ground segment, but on the margins designed into the links to accommodate the propagation attenuation due to rain. Propagation impairment at Ka-band due to rain is an important factor in the design and implementation of the elements of the Rainbow Ka System.

The spacecraft of the Rainbow Ka System will be capable of being placed into the GSO by launchers such as Ariane 5, Atlas V, Delta IV, and Sea Launch.

^{1/} Service in Canada and Mexico would start only when authorized by appropriate Canadian and/or Mexican governmental authorities.

II. ORBIT LOCATIONS AND FREQUENCY USAGE

In two earlier processing rounds the Commission has licensed more than twenty companies to operate Ka-band satellites at more than 75 orbit locations in the GSO. About 35 of these locations could serve the nations of ITU Region 2, including the U.S. However, several licensees have notified the Commission that they do not intend to use their licenses at a number of orbit locations. In addition, because of the recent limited availability of investment funds for telecommunications, it would not be surprising if the Commission were to receive the return of additional Ka-band licenses.

As the Commission notes, the U.S. government (“U.S.G.”) is also using some of the Ka-band FSS, ITU-allocated spectrum for its satellites in some parts of the GSO arc suitable for service to Region 2. Coordination by the Commission’s FSS Ka-band licensees with these U.S.G. Ka-band networks is required by footnote US334 of the Commission’s allocation table (§2.106 of the FCC Rules). Moreover, other administrations (including several outside Region 2) have initiated the ITU-R notification procedure for Ka-band satellite networks in the portion of the GSO arc suitable for Region 2 service.

A. Requested Orbit Locations

Rainbow DBS Company, LLC (“Rainbow DBS”) hereby requests authorization to build, launch and operate satellites operating in the Commission’s allocated FSS Ka-subbands at 71° W.L. and 119° W.L.^{2/} Rainbow DBS recognizes that coordination will be required with the U.S.G. Ka-band satellites and other Commission licensees, as well as those of other administrations.

B. Coverage

From the paired 71° W.L. and 119° W.L. orbit locations, the Rainbow Ka System will be able to provide service in all 50 states of the U.S., as well as the southern tier of Canada and northern Mexico. Table 2-1 lists the elevation angles to major U.S. cities from both of these orbit locations. Elevation angles, as is well understood, are one of the important factors in designing required margins to obtain the desired link availability at frequencies above 10 GHz.

Figures 4-4 and 4-5 illustrating how the multi-spot beam satellites in the Rainbow Ka System will provide coverage on the Earth are included in Section IV of this Exhibit.

^{2/} While licenses for both of these locations had been assigned during a previous Ka-band processing round but in both locations, the licensees have voluntarily relinquished their authorizations.

C. Frequency Plan

Article 5 of the ITU Radio Regulations (“RR”) lists the bands shown below as being allocated to the FSS on a Primary basis in Region 2, which includes the U.S.

17.8 to 21.2 GHz – space-to-Earth

27.0 to 31.0 GHz – Earth-to-space

In almost all subbands of these large blocks of spectrum, the FSS shares Primary status with one or more other services, such as the Fixed Service (“FS”), Mobile Service (“MS”), Mobile Satellite Service (“MSS”), Space Research Service (“SRS”) and/or the Earth Exploration-Satellite Service (“EES”).

The U.S. table of allocations in the FCC Rules (see §2.106) presents a different situation. Highlights of the differences with the ITU Table are:

- Large segments of the space-to-Earth band are assigned to both U.S.G. and non-government use on a Primary basis.
- In the space-to-Earth allocations, there has been an attempt to reduce the requirements for sharing among services by limiting Primary authorization to one or in a few instances, two services in each subband.

However, in the Earth-to-space Ka-bands, the U.S. Table is quite similar to the ITU Table in that large blocks of spectrum include co-Primary allocations for two or more services. Therefore it is necessary to find the assignment of services to specific uplink Ka-subbands for U.S. service in several of the Commission’s Orders and/or its Rules.

Thus, the Rainbow Ka System will use the Ka-band spectrum for space-to-Earth operations - 18.3-18.8 GHz; 19.7-20.2 GHz; and for Earth-to-space operations - 28.35-28.6 GHz; 29.25-30.0 GHz

The frequency plan for the Rainbow Ka System is shown in figure 2-1. A total of one GHz of bandwidth is employed for both the uplink and downlink. The payload of the Rainbow Ka satellites operate a symmetrical bandwidth system using hubs for routing all communications signals. Two distinct equal-bandwidth signal paths are provided. That is, there is an outbound or

Table 2-1

SUMMARY ELEVATION ANGLES FOR PROPOSED ORBIT LOCATIONS

		<i>Albuquerque</i>	<i>Boise</i>	<i>Chicago</i>	<i>Denver</i>	<i>El Paso</i>	<i>Los Ange</i>	<i>Phoenix</i>	<i>SaltLakeC</i>	<i>San Fran</i>	<i>Seattle</i>	
Earth Station Latitude	deg N	35.08	43.82	41.88	39.72	31.75	34.05	33.45	40.77	37.80	47.60	
Earth Station Longitude	deg W	106.67	117.02	87.63	105.02	106.48	118.25	112.08	111.88	122.40	122.33	
Elevation angle to sat at	deg W	71.0	34.5	22.0	38.8	32.3	36.9	26.5	31.6	27.2	21.5	16.6
Elevation angle to sat at	deg W	119.0	47.2	39.5	32.1	41.8	50.6	50.4	50.4	42.3	46.1	35.2

		<i>Atlanta</i>	<i>Dallas</i>	<i>Boston</i>	<i>Miami</i>	<i>New York</i>	<i>Wash.D.C.</i>	<i>Honolulu</i>	<i>Anchorage</i>	<i>Nome</i>	
Earth Station Latitude	deg N	33.75	32.77	42.35	25.77	40.72	38.90	21.32	61.22	64.50	
Earth Station Longitude	deg W	84.38	96.80	71.07	80.20	74.02	77.02	157.87	149.88	165.40	
Elevation angle to sat at	deg W	71.0	48.2	42.8	41.1	58.2	42.8	44.5	NA	NA	NA
Elevation angle to sat at	deg W	119.0	36.2	45.0	21.6	37.7	24.5	27.7	39.8	16.1	8.7

forward link from the hubs to the users and an inbound or return path from the users to the hubs. Users in each beam utilize approximately 108 MHz of downlink and uplink bandwidth. Each hub employs 500 MHz of bandwidth in each direction. A “four-color” frequency plan for user beams allows for frequency reuse of: (i) up to 12 times (12 = 48 beams / 4 frequencies) for all frequency bands on the Rainbow Ka satellite at 71° W.L., as depicted in Figure 4-4; and (ii) up to 15 times (15 = 57 beams / 4 frequencies rounded up) for all frequency bands on the Rainbow Ka satellite at 119° W.L., as depicted in Figure 4-5. Each hub serves the four user beams in a “color” group.

The hub uplink utilizes the 28.35-28.6 GHz and 29.25-29.5 GHz frequency bands on one sense of circular polarization. The downlink to the hubs employs the 18.3-18.8 GHz frequency bands on the other sense of circular polarization. The user uplinks utilize the 29.5-30.0 GHz frequency band and the user downlinks employ the 19.7-20.2 GHz frequency band on right hand circular polarization.

On the return link, each of four user beams is assigned 108 MHz of the available 500 MHz of bandwidth (17 MHz is employed as guard bands for each user beam). A total of up to 15 ‘color’ groups reuse and share the same 500 MHz bandwidth. Each 108 MHz is shared among all users in a beam using FDMA/TDMA access methods. For each of up to 15 ‘color’ groups, the four 108 MHz user channels are combined on the satellite, amplified by the satellite high power amplifiers and transmitted to the appropriate hub beam as a composite signal. Because of the multi-carrier operation, all satellite amplifiers are operated in a backed-off state to provide linear operating characteristics.

On the forward link, each of the hubs transmits four multiplexed 108-MHz channels to the satellite where the signals are demultiplexed into individual 108-MHz channels. Each of the 108-MHz channels are amplified linearly and transmitted to the appropriate user beam downlink.

In addition, spacecraft command and telemetry carriers for on-station use and downlink beacons for pointing and uplink power control uses are accommodated in the Ka-band spectrum. The downlink beacons for pointing and uplink power control use an unmodulated tone that is transmitted through a dedicated elliptical coverage antenna that covers the planned service areas. The beacon frequency will be at the upper edge of the 19.7-20.2 GHz frequency band and conform to applicable power flux density limits in that band.

Figure 2-1 – Rainbow Ka Frequency Usage Concept

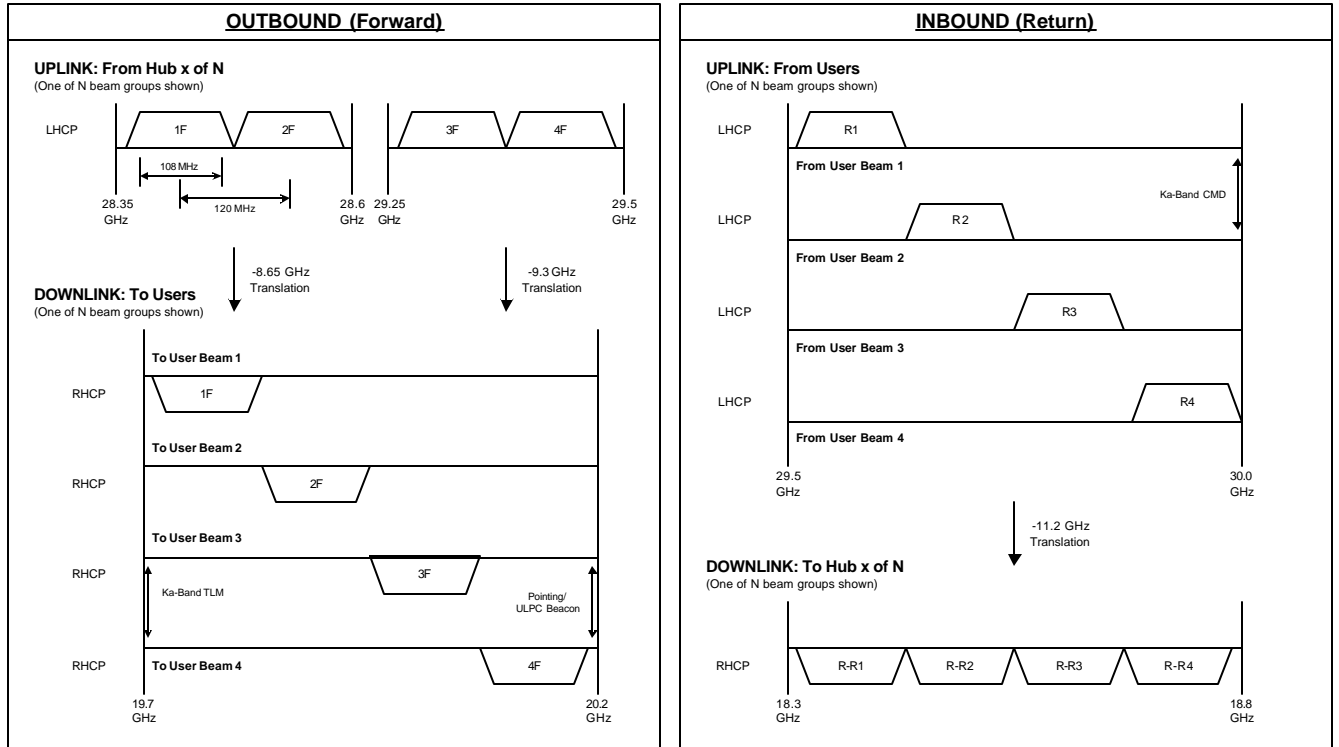

III. SATELLITE NETWORK DESCRIPTION

There are two types of links in the Rainbow Ka System. They are the hub-to-user (forward or outbound) and the user-to-hub (return or inbound) links. As indicated in the frequency plan above, the 500 MHz dedicated to each type of link is divided into four 125 MHz segments.

In the forward link, the hub directs four multiplexed 108 MHz subbands (17 MHz of each 125 MHz is used for guard bands) to the satellite, which demultiplexes the 500 MHz and directs each of the four subbands to a different user beam in the 'color' group. Using FDMA, each 108 MHz subband will include four wideband (about 24 MHz) digital signals. Each wideband signal is QPSK modulated and forward-error corrected with advanced coding techniques to deliver at least 24 Mbps to the user in a time division multiplexed ("TDM") mode. Each user will be able to "pick-off" the data addressed to him (or her) in the TDM signal.

In the return direction (user-to-hub), again, the 500 MHz is divided into four subbands with 125 MHz (including guard bands) assigned to each beam. In each 125/108 MHz subband there will be a number of different types of FDMA/TDMA channels to accommodate the variety of needs arising from the diversity of Rainbow Ka System customers. One of these channels will be used as an order wire at 1.544 Mbps for service requests, acknowledgment and assignments. The other uplink TDMA channels will have differing bandwidth/bit rates. At this time, because the services and markets are still not defined in detail, Rainbow planning includes three levels of TDMA return service links. They are: another two at 1.544 Mbps and the others at 3.152 Mbps and 10 Mbps. The user would be assigned time slots in the appropriate type of channel depending upon its request for 'bandwidth' and the capability of its earth station.

The uplink signals from each of four user beams will be received at the satellite, multiplexed and downlinked in a hub beam channel of 500 MHz.

Emission designators for the currently planned forward and return service link signals are listed below:

25M7G7W

1M80G7W

3M40G7W

12M0G7W

The emission designators for the TT&C signals are:

1M50FXD

600KG7D

Link budgets for typical links and earth stations are in Appendix A. The assumptions used in calculating these link budgets are in the Foreword of Appendix A.

The NOCs will be established adjacent to several hub earth stations, although at the start of service only one or two NOCs may be implemented and terrestrial lines will be used to transport the requisite data between the hubs. The NOC will accomplish: bringing customers into the system, user service requests and acknowledgments, beam loading and network control management. In addition, the NOC will generate the data required for customer billing, determining service quality, delisting non-paying users, etc.

Because propagation impairment due to rain at Ka-band frequencies can be significant, it is an important consideration in the design of the elements of the Rainbow Ka System network. The specific attenuation per kilometer of path length in rain at the Ka-band downlink of 20 GHz is 2.5 to 3.5 times (4 dB to over 5 dB) greater than that at the Ku-band downlink of 12 GHz. The differential between the 30 GHz Ka-band uplink and the 14 GHz Ku-band uplink is even greater. Of course, the signal path length in a rain cloud can be greater than one kilometer, especially at low elevation angles, and therefore the difference in attenuation can be significantly greater than that indicated by the specific attenuation differentials. However, in the case of the earth station transmissions, adaptive power control is economically feasible for even consumer earth stations. And in fact, the Commission's rules^{3/} require adaptive uplink power control (or an equivalent) for Ka-band earth stations.

^{3/} See 47 CFR § 25.204(g).

IV. Space Segment

A. Spacecraft Description

A.1. General Description

The satellites in the Rainbow Ka System will be designed and built by one of the current aerospace manufacturers specializing in large, complex communications satellites, such as: Boeing Satellite Systems, Loral/Space Systems Division or Lockheed Martin Commercial Space Systems (“Lockheed Martin”). In fact, the spacecraft description herein was prepared with Lockheed Martin’s assistance.

Figures 4-1 and 4-2 show the planned Rainbow Ka spacecraft in stowed and in-orbit configurations, respectively. Table 4-1 summarizes some of the important aspects of the Rainbow Ka spacecraft platform and subsystems as configured by L-M. Preliminary spacecraft mass and power budgets are given in Tables 4-2 and 4-3. The Rainbow Ka satellites have been configured such that each will provide full capacity to all users in all beams with a probability of success of 0.93 at the end of 5 years, 0.83 at the end of 10 years and 0.70 at the end of 15 years. Probabilities of useful service to users by the pair of satellites will be considerably greater than those for a single satellite, cited above.

Figure 4-1 – Spacecraft in Stowed Configuration for Launch

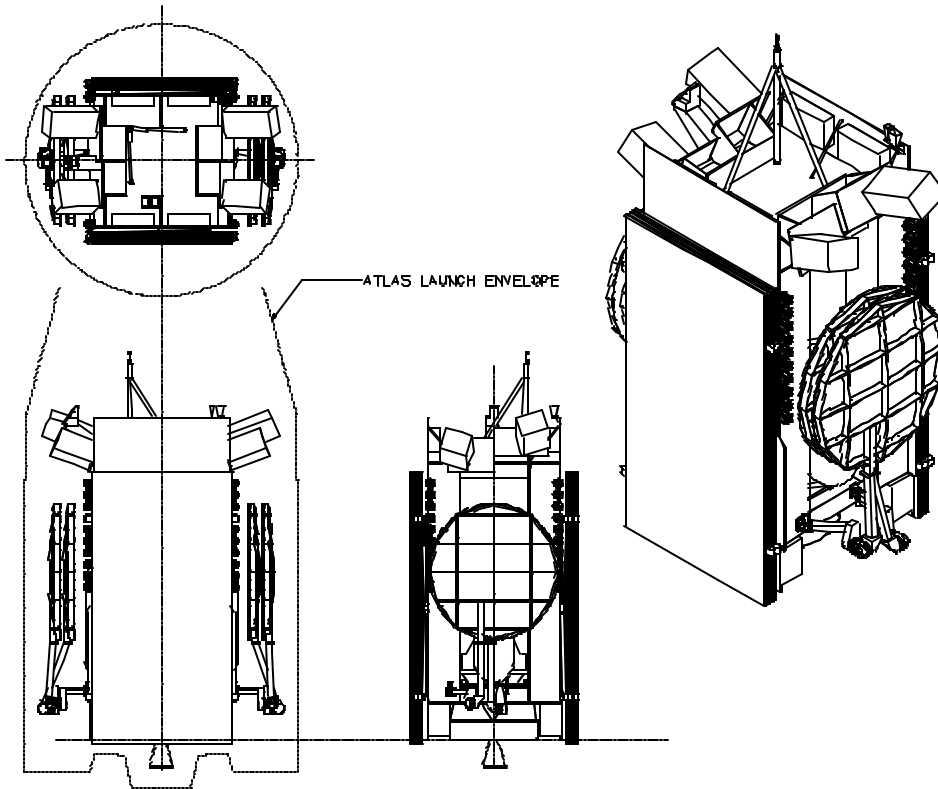

Figure 4-2 – Spacecraft in Mission Configuration In Orbit (dimensions in inches)

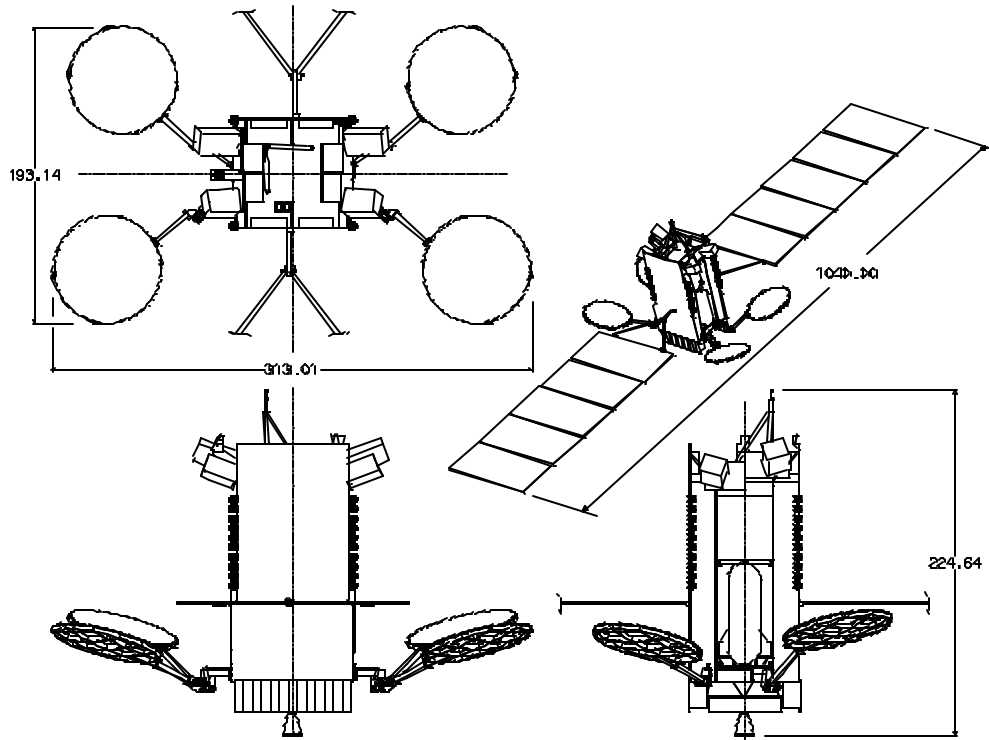

Table 4-1 Features of The Rainbow Ka Spacecraft Platform and Subsystems

General	
Design Mission Life: 15 years	Platform reliability target (15 years): > 95%
Propulsion	Attitude Determination and Control Subsystem
Liquid “Dual-mode” system provides all propulsive functions	3-axis control system with near zero net momentum
High efficiency bipropellant liquid apogee engine	Fully autonomous fault detection, isolation, and recovery
High-performance arcjet thrusters for north/south stationkeeping	On-orbit steering and pointing offset capability
	Low-thrust rockets provide accurate control during stationkeeping
Power Subsystem	Telemetry, Command & Ranging Subsystem
Highly regulated, direct energy transfer power supply	Secure command link, configurable to INTELSAT, ESA, or U.S. domestic telecommand standards
Single-axis, multi-panel solar array using triple-junction solar cells	Configurable to any one of four telemetry rates
Energy storage via nickel-hydrogen batteries	Re-programmable telemetry frame contents
Thermal Subsystem	Structure/Mechanisms
Embedded heat pipes in payload panels	Highly modular structure design
Ground commandable adjustment of heater set points	All mechanisms qualified to 1.5 times design life

Table 4-2 – Preliminary Spacecraft Mass Budget

Item	Mass (kg)
Spacecraft Platform	1400
Communications Payload	900
Dry Mass Total	2300
Pressurant, Fuel & Oxidizer	2300
Lift-off Mass	4600
Lift-off Capability (Atlas V)	5190
Margin	590

Table 4-3 – Preliminary Spacecraft Power Budget

Item	Power (Watts)	
	Equinox Eclipse	Summer Solstice
Communications Payload	6900	6900
Spacecraft Platform	500	600
Battery Recharge	0	400
Spacecraft EOL Power	7400	7900
Solar Array EOL Power	N/A	8400
Margin	N/A	6.3%
Battery Depth of Discharge (nominal)	80%	N/A

A.2. Attitude Determination and Control Subsystem (AD&CS)

During normal operations, the satellites of the Rainbow Ka System will employ 3-axis stabilization using reaction wheels and a continuously active gyro inertial reference. The spacecraft are designed to maintain antenna pointing within $\pm 0.05^\circ$ of a nominal pointing direction during the normal operating mode. The AD&CS will maintain spacecraft orbit inclination and longitudinal drift within $\pm 0.05^\circ$ of nominal pointing direction.

A.3. Orbital Debris Mitigation

To control orbital debris, the Rainbow Ka System will use a satellite and launch vehicle design that minimizes the amount of debris released during normal operations. Rainbow will

also conduct an analysis that demonstrates that no realistic failure modes exist or can lead to an accidental explosion during normal operations or before completion of post operations disposal. At the end of the operational life of the GSO satellite, Rainbow will maneuver its spacecraft to a storage orbit with a perigee that is at least 150 kilometers above a normal GSO operational orbit. After the Rainbow Ka spacecraft has reached its final disposal orbit, all on-board sources of stored energy will be deleted or safely secured.

B. Communications Payload Description

B.1. Communications Payload Overview

The Rainbow Ka System communications payloads will employ state-of-the-art designs and components, utilizing advanced Ka-band antenna technology and efficient Ka-band traveling wave tube amplifiers (TWTAs) in a bent-pipe architecture. A functional block diagram of the communications payload is shown in Figure 4-3. The signal flow and functions of the various equipment blocks in the communications payload are briefly described below.

Figure 4-3 – Rainbow Ka Communications System

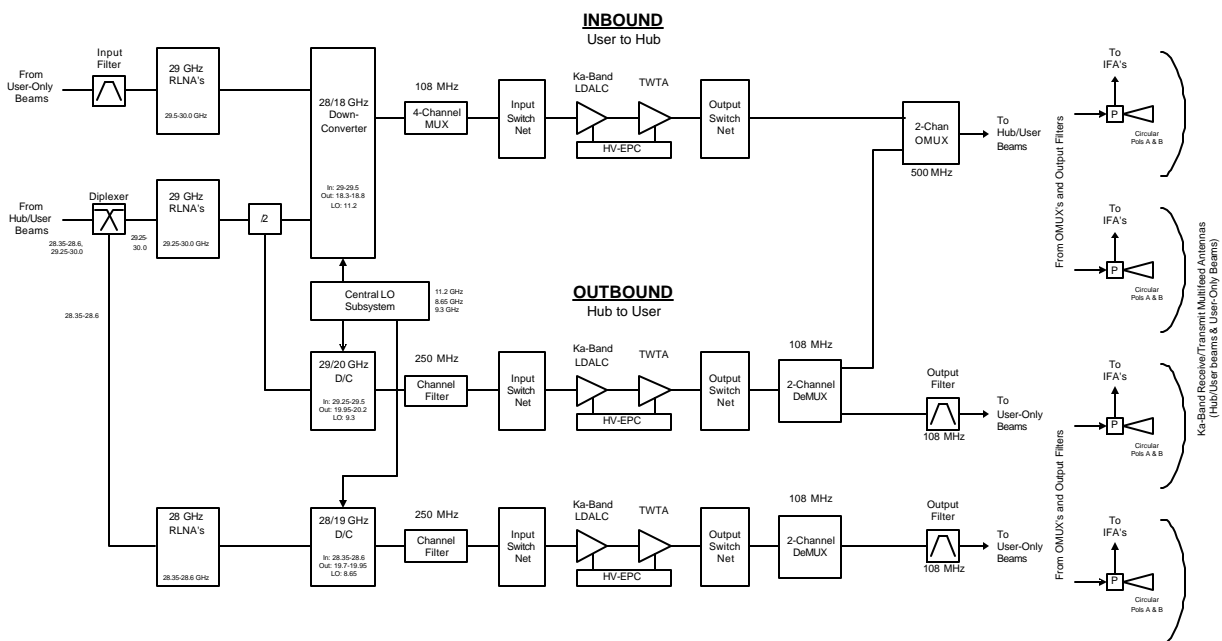

The Rainbow Ka satellite payload will include four parabolic antennas to provide up to a total of 57 spot beams covering the contiguous United States (CONUS) -- as well as Hawaii and Alaska for the spacecraft in the 119° W.L. orbital location. Each antenna provides dual

polarized, diplexed receive and transmit capabilities and each has multiple feed horns to generate congruent receive and transmit beams. Each beam provides services to all users in that beam. One of every four beams in a 'color' group is designated a combined user/hub beam, that is, it services a hub in that beam as well as all users.

Received signals from the ground segment are bandpass filtered and amplified by low noise amplifier/receivers, downconverted to the transmit frequency, filtered by appropriate channel filters and multiplexers and fed to the high-power amplifiers (TWTA's). The output of the TWTA's are demultiplexed and filtered into individual user-beam channels and individually filtered (and then multiplexed) for the hub/user beams, and fed to the antennas for transmission to the ground. Appropriate redundancy switching exists on the input and output side of the transponder chains. The TWTA's are sized to provide adequate EIRP to the users and the hubs. Each of the 120 Watt TWTAs provides power for two user beams. The TWTAs will be operated in a nominal 3 dB backed-off condition because of their multi-carrier operation. The TWTAs that service the hub downlinks are nominally 60 Watts and will also be operated in a nominal 3 dB backed off condition due to multi-carrier operation.

Normal equipment redundancy techniques are used in the payload for all active equipment. Spare receivers, frequency generation components and TWTAs are included in the payload.

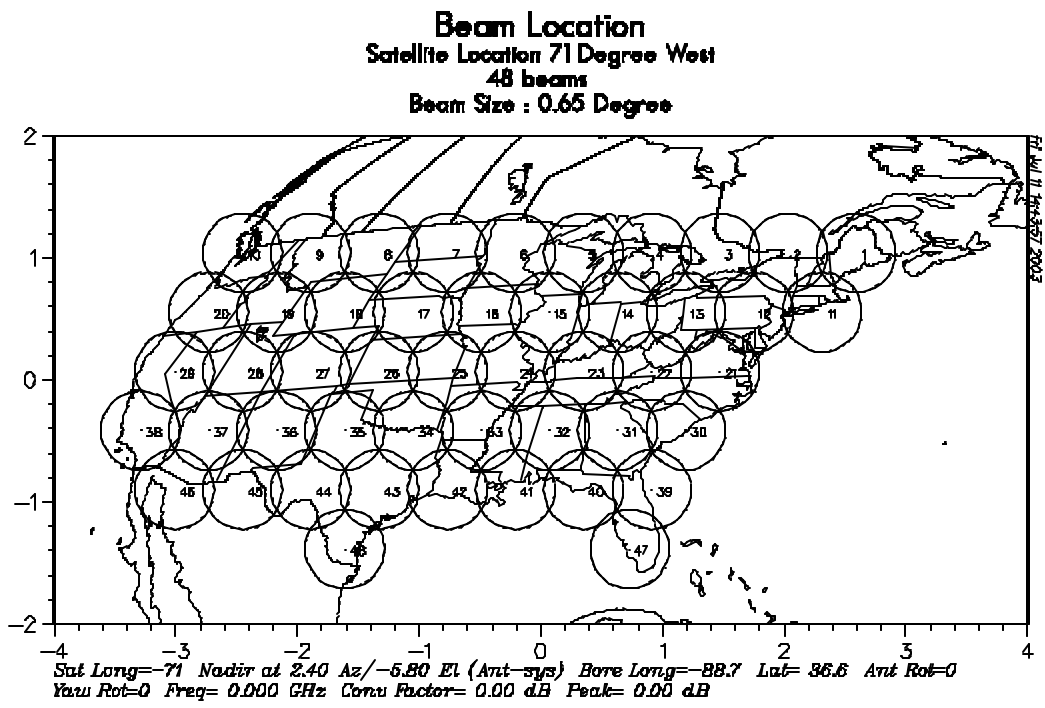
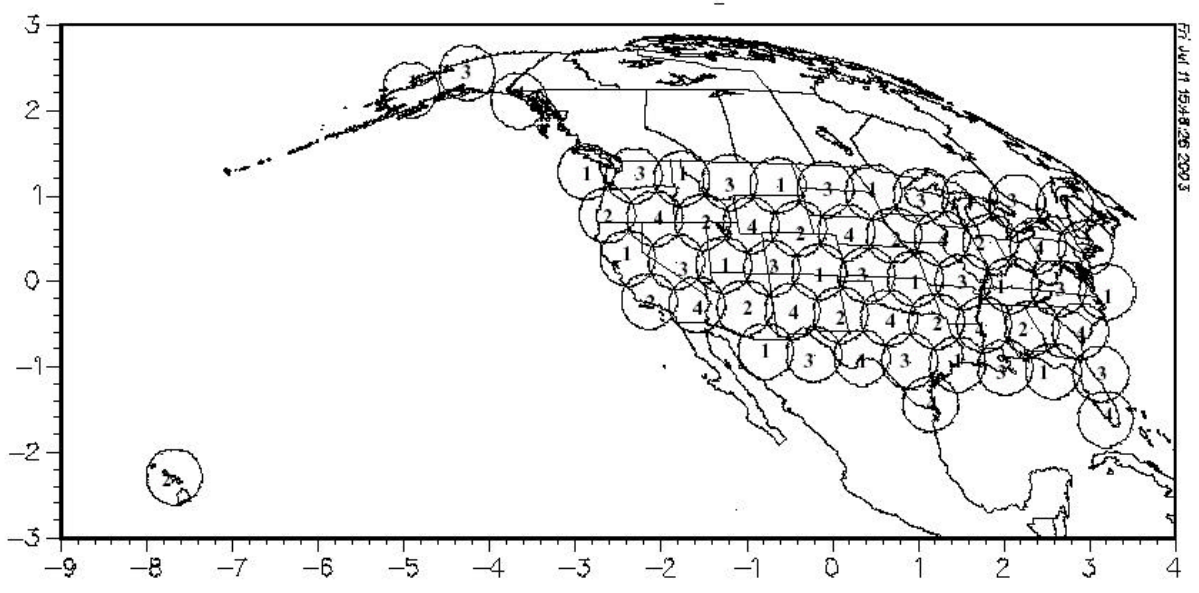

Figure 4-4 – Rainbow Ka Four Color Frequency Reuse – Eastern Orbital Slot



Satellite Location 119° W.L. – 57 beams – Beam size 0.65°

Figure 4-5 – Rainbow Ka Four Color Frequency Reuse – Western Orbital Slot

B.2. Payload Operating Characteristics

B.2.1. Transponder Gain Control and Saturation Flux Density

The transponders in the payload can operate in one of two modes of operation: fixed gain and automatic level control (ALC) mode. In fixed gain mode, the saturation flux density at the satellite will be controllable over a 20 dB range in 1 dB increments. In ALC mode, the uplink dynamic range shall be no less than 30 dB. The ALC mode drive power to the TWTA shall be commandable over a range of +5 to -13 dB.

B.2.2. Transmission Channel Frequency Response and Unwanted Emissions

The Rainbow Ka satellite receive and transmit channel filter responses are not yet fully defined but the transmissions will meet, as a minimum, the out-of-band limitations of §25.202(f). The final in-band frequency responses will be determined taking into account the requirement for negligible bit error rate degradation under all practical conditions. The final out-of-band frequency responses will be determined taking into account the requirements for protecting the receiver front-end amplifiers from overload due to out-of-band signals, and adequate suppression of unwanted out-of-band emissions from the satellite.

B.2.3. Frequency Stability

The on-board frequency reference used to frequency translate the Rainbow Ka satellite signals is designed with a frequency tolerance of better than one part in 10^{-6} over the short-term, and better than eight parts in 10^{-6} over the long term.

B.2.4. Cessation of Emissions

Each satellite downlink beam, telemetry transmitter, and beacon will be capable of being individually turned off by ground telecommand in order to cease satellite emissions, as required.

B.3. Satellite Antennas

The Rainbow Ka antenna suite includes four 1.78 meter transmit/receive antennas deployed in pairs from the east and west sides of the spacecraft. Each antenna employs an offset fed reflector illuminated by up to 15 individual dual circularly polarized transmit/receive feed horns. Each feed element generates one spot beam within the coverage area. The reflector geometry has been selected to meet the electrical performance requirements while meeting all of the spacecraft and launch vehicle constraints. The coverage areas for multi-spot beam antennas

on the Rainbow Ka satellites at 71° W.L. and 119° W.L. are shown in Figures 4-4 and 4-5. The deployed configuration of the antennas on the Rainbow Ka spacecraft is shown in Figure 4-6.

Figure 4-6 Rainbow Ka-band Satellite

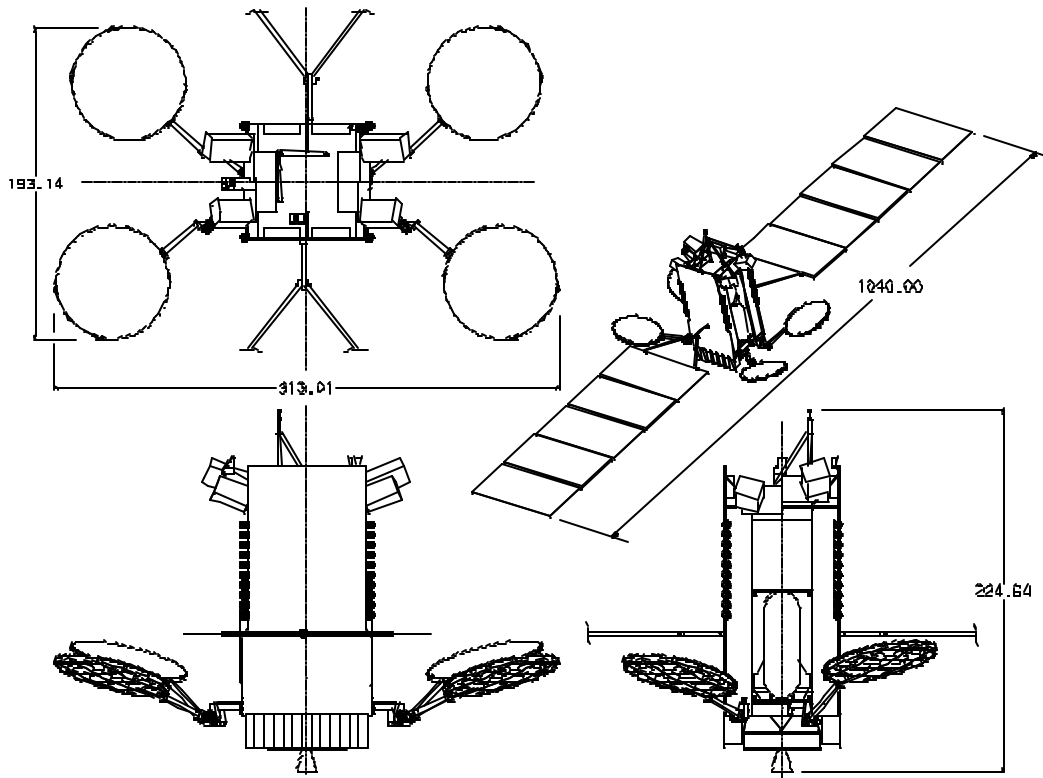

Electrically, each feed generates both orthogonal circular polarizations. The feedhorn is connected to an orthomode transducer (OMT) to separate the two circularly polarized signals. The outputs of the OMT are connected to diplexers that combine the hub and user downlink signals on one polarization sense and separate the hub and user uplink signals on the orthogonal polarization.

B.3.1. Receive Performance

The satellite antenna performance for user and hub uplink beams is summarized in Table 4-4. It should be noted that the rightmost column represents worst-case performance for beams operating near the edge of coverage which suffer maximum off-boresight scan loss. The receive antenna gain performance for a typical CONUS beam is in Figure 4-8.

Table 4-4 Satellite Receive Performance for User Terminal and Hub Uplinks

Parameter	Units	Beam Peak at Nadir	Beam Edge
Receive Antenna Directivity	dBi	53.6	42.9
Receive System Noise Temperature	dBK	30.5	30.5
Receive G/T (End of Life)	dB/K	23.1	11.4

B.3.2. Transmit Performance

The satellite antenna performance for user downlink beams is summarized in Table 4-5 and for hub downlink beams in Table 4-6. It should be noted that the rightmost column represents worst-case performance for beams operating near the edge of coverage which suffer maximum off-boresight scan loss. The satellite antenna gain performance for a typical transmit beam is in Figure 4-7.

Table 4-5 Satellite Transmit Performance for User Terminal Downlinks

Parameter	Units	Beam Peak at Nadir	Beam Edge
TWTA Power	dBW	14.8	14.8
Post TWTA Losses	dB	3.4	3.4
Antenna Directivity	dBi	50.0	45.0
EIRP	dBW	61.4	56.4

Table 4-6 Satellite Transmit Performance for Hub Downlinks

Parameter	Units	Beam Peak at Nadir	Beam Edge
TWTA Power	dBW	14.8	14.8
Post TWTA Losses	dB	3.4	3.4
Antenna Directivity	dBi	50.0	45.0
EIRP	dBW	61.4	56.4

FIGURE 4-7
Relative Tx Directivity 19.5 GHz 119° Center Beam

Relative Directivity Contour
Satellite Location 119 Degree West
Contour Level: -2 -4 -6 -8 -15 -20 from Peak
Peak=49.90 dBi

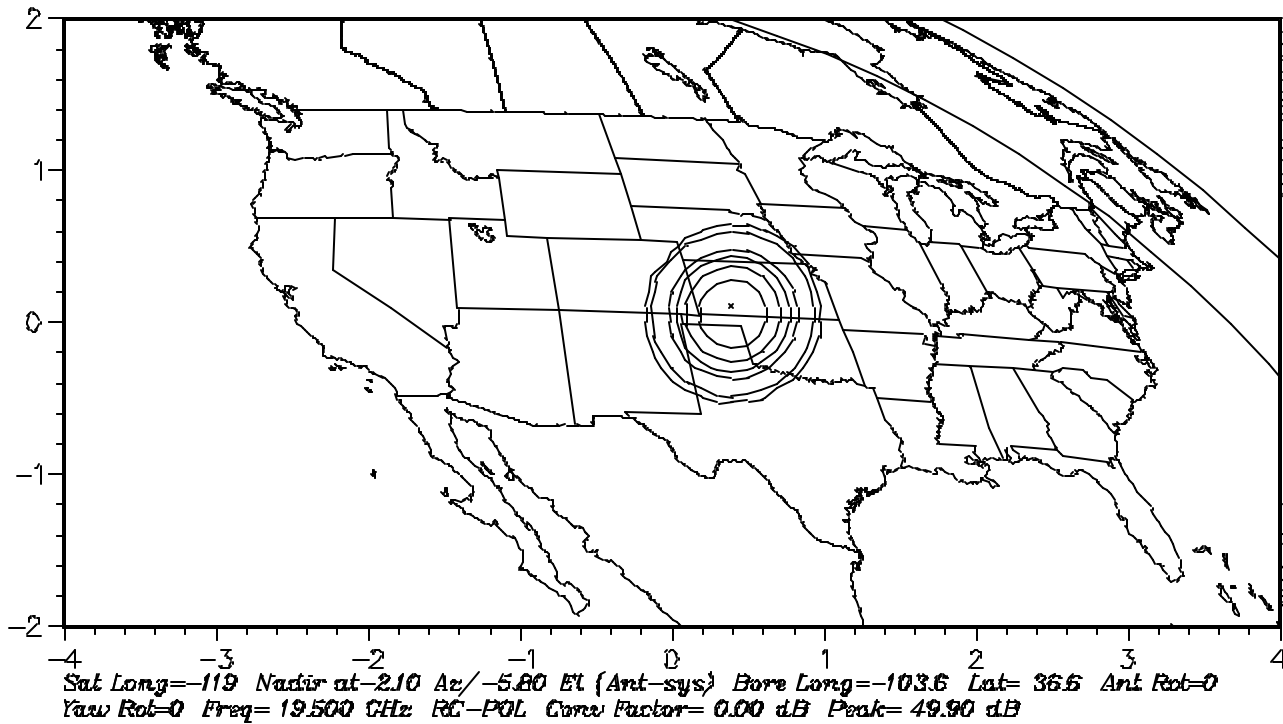
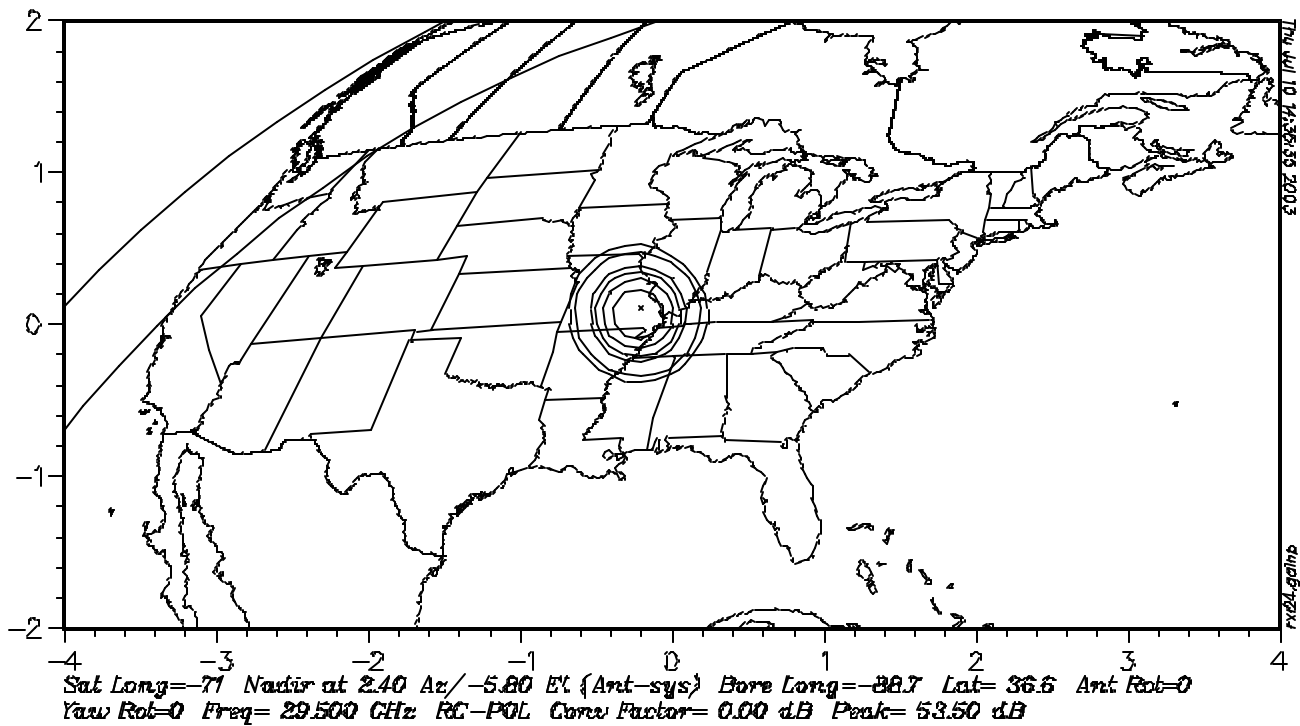

FIGURE 4-8

Relative Rx Directivity 29.5 GHz 71° Center Beam

Relative Directivity Contour
Satellite Location 71 Degree West
Contour Levels: -2 -4 -6 -8 -15 -20 from Peak
Peak=53.50 dBi



C. TT&C Subsystem

C.1. TT&C Subsystem Description

The TT&C RF subsystem is designed to operate in the Ka-band during on-station operations.^{4/} Command signals will be transmitted to the spacecraft at 29.998 GHz. The command uplink consists of a command carrier frequency modulated by digital commands at a maximum data rate of 1024 bits per second. Telemetry transmission from the spacecraft during on-station operations will be at 19.702 GHz. The telemetry carriers are phase modulated with telemetry data streams at a maximum data rate of 4096 bits per second. Two-way ranging is accomplished by substituting range tones for commands on the uplink. The demodulated ranging tones are then remodulated onto the downlink telemetry carrier. Spacecraft range is estimated by measuring the phase shift between the transmitted and received tones at the ground station.

During on-station operations, command reception at the spacecraft is via a CONUS Ka-band receive horn that provides high directivity over the required coverage. The CONUS receive horn feeds the command receivers. The CONUS receive horn is left-hand, circularly polarized. Similarly, on-station telemetry transmission coverage will be via a CONUS Ka-band telemetry horn that provides high directivity over the required CONUS coverage. The Ka-band telemetry horn is right-hand, circularly polarized for downlink telemetry transmission.

^{4/} To the best of Rainbow DBS's and Lockheed Martin's knowledge currently existing launch and transfer orbit command and telemetry facilities are not available using Ka-band frequencies. At the time the Rainbow Ka System satellites complete their CDR the situation will be clearer and any necessary applications will be submitted for the TT&C facilities needed for launch and transfer orbit.

A list of important TT&C RF link parameters is given in Table 4-7

Table 4-7 – TT&C RF Link Parameters

Parameter		Unit	Normal On-Station Operations
Command	Frequency	MHz	29998.0
	Coverage	N/A	CONUS Horn
	Flux Density	dBW/m ²	-90
	Modulation	N/A	PCM-RZ/FSK/FM
	Data Rate	bps	1024
Telemetry	Frequency	MHz	19702.0
	Coverage	N/A	CONUS Horn
	EIRP	dBW	+10
	Modulation	N/A	Biphase-L/PSK/PM
	Data Rate	bps	4096
Ranging	Frequency U/L	MHz	29998.0
	Frequency D/L	MHz	19702.0
	Modulation U/L	N/A	PM/FM
	Modulation D/L	N/A	PM/PM
	Tone Frequencies	Hz	0, 35, 283, 3968 on 27.78-kHz subcarrier or 27.78-kHz fine tone

C.2. TT&C RF Link Budgets

Table 4-8 shows the link budget for spacecraft command and ranging uplinks for the normal on-station operation mode. Table 4-9 shows the link budgets for telemetry for the same operational mode of the spacecraft.

Table 4-8 – TT&C Command and Ranging Uplink Budget

Parameter	Unit	Mission Operations Ka-Band CONUS Horn 29.998 GHz
Earth Station EIRP	dBW	93.00
Earth Station Pointing Loss	dB	-0.50
Spreading Loss	dB-m ²	-163.00
Atmospheric Loss	dB	-0.40
Polarization Misalignment Loss	dB	-0.10
Rain Loss	dB	-19.00
Flux Density at the spacecraft	dBW/m ²	-90.00
Isotropic Aperture Area	dB-m ²	-50.99
Spacecraft Receive Antenna Gain	dBic	22.00
Spacecraft Passive Loss	dB	-6.90
Spacecraft Received Power	dBW	-125.89
Required Command Power	dBW	-138.00
Command Margin	dB	12.11
Required Ranging Power	dBW	-135.00
Ranging Margin	dB	9.11

Table 4-9 – TT&C Telemetry and Ranging Downlink Budget

Mission Mode:	On-Station	
Antenna:	CONUS HORN	Unit
TM Transmitter Output Power	3.00	dBW
Spacecraft Passive Loss	-4.40	dB
Multipath Allocation	0.00	dB
Polarization Loss	-0.10	dB
Transmit Antenna Gain	22.00	dBi
Calculated EIRP	20.50	dBW
Rain Loss Allocation	-7.20	dB
Spacecraft Effective EIRP	13.30	dBW
Free Space Loss	-210.91	dB
Atmospheric Loss	-0.40	dB
Earth Station Pointing Loss	-0.40	dB
Earth Station Figure of Merit	35.00	dB/°K
Boltzman Constant	228.60	dBW/°K-Hz
Received C/No	65.19	dB-Hz
Required TM C/No	61.10	dB-Hz
Telemetry Margin	4.09	dB
Required Ranging C/No	58.99	dB-Hz
Ranging Margin	6.20	dB

C.3. TT&C RF Power Flux Density

There is no power flux density limit in the ITU Radio Regulations nor the FCC Rules for use of the band 19.7-20.2 GHz by satellites in the GSO.^{5/}

The maximum PFD for the TT&C downlink corresponding to the shortest range from the satellite at 90° elevation, is -152 dBW/m^2 . Since the telemetry bandwidth is less than 2 MHz, the telemetry PFD would be less than $-148 \text{ dBW/m}^2/\text{MHz}$, which is far less than any of the FCC or ITU limit in this band.

^{5/} There is a limit in the FCC Rules for blanket licensing of earth stations in the 20 GHz band. See 47 CFR §25.138.

C.4. TT&C Earth Stations

It is likely that the TT&C earth station for the Rainbow Ka-band spacecraft will be located at the existing Rainbow TT&C site for its Rainbow-1 DBS satellite, which is in the vicinity of Rapid City, SD. The station currently has one 13.2 meter Limited Motion Antenna (LMA) and one 8.0 meter LMA, both operating in the 12/17 BSS band of frequencies. A Ka-band antenna implementation will probably have a 13.2 meter diameter antenna with separate transmit and receive feeds. The Ka-band antenna/RF equipment shall support primary, on-station geostationary TT&C uplink of command and ranging signals to the spacecraft and downlink of ranging signals and telemetry signals from the spacecraft. In addition, the system shall include a method to recover the spacecraft telemetry signal from either antenna polarization and provide signal conditioning prior to decommutation.

The LMA will satisfy the requirements for Ka-band uplink EIRP of 88 dBW and a G/T of 37 dB/^oK at the Ka-band telemetry frequency band. The short term G/T stability for the LMA shall be ± 0.35 dB per hour.

V. EARTH SEGMENT

The earth segment of the Rainbow Ka System will consist of hub and user earth stations, the NOCs and an SOC. As noted above, and in distinction to the situation in C- and Ku-band satellite systems, rain attenuation at Ka-band and required availability requirements are very important inter-related factors in the design and siting of earth stations used in the Rainbow Ka System. This application does not request authorization for the earth stations. However, in order to ensure compatibility with the Commission's two-degree spacing requirements as well as the ability to share the spectrum with other co-Primary users, Rainbow will ensure that all the earth stations accessing its system will meet the Commission's Rules for earth station performance.

A. Hub Earth Stations

In the Rainbow Ka System there will be one hub earth station for each four user beams. Each hub earth station will utilize an antenna with a diameter of 3.5 to 5.5 meters. The choice of antenna diameter will be primarily based on its location, the serving satellite, its position relative to the center of the hub/user beam and the rain zone in which it will be located. The link budgets in Attachment A employ 3.5 meter diameter antennas for the hub earth stations. At this size, assuming a location within the -3 dB contour of the satellite receive beam center,^{6/} these hub earth stations should achieve an availability exceeding 99.7% on an annual basis. If it is determined that greater availabilities are needed, a larger diameter antenna and/or improved siting would be employed. These hub earth stations, under the control of the NOC(s), will be the interface between the Rainbow Ka System network and the terrestrial network.

B. Consumer/User Earth Stations

Since there will be a wide diversity in the requirements of the users of the Rainbow Ka System -- and they will be located in a very wide disparity of climates (from sub-tropic to frozen tundra, or Key West to Nome), the user earth stations operating in the Rainbow Ka System will come in a variety of sizes, shapes and flavors. Users will range from the casual consumer to the intensive business or governmental entity, further increasing the diversity in requirements.

All user earth stations will be capable of receiving the 24 Mbps forward link signals from the hub. The percentage availability of these signals will depend on the earth station location, the diameter of its antenna and the orbit location of the satellite serving it. Users in almost all the planned service area (the exception being the Southeast U.S. and part of Mexico and Alaska)

^{6/} It will be a requirement to locate hub earth stations near the aim point of the satellite beam.

should be able to employ earth stations whose antenna diameters are 65 centimeters and achieve availabilities of 99% of the worst month (99.7% annually) or better.^{7/}

A further determination of cost and size of the user earth station will be its transmit data capability. Obviously, the greater the desired capacity, the greater the cost, which would be incurred either because of an increase in antenna diameter or a higher power transmitter or additional terminal equipment.

It should be noted that the use of even a several watt RF transmitter operating near humans will require special care in the siting of the antenna of consumer earth stations so as to preclude the potential for harmful radiation effects^{8/} on humans and other animals. Thus, Rainbow will insist on professional installation of all earth stations in the Rainbow Ka System. As noted earlier, Rainbow plans (and the Commission requires)^{9/} that earth stations in its system employ adaptive uplink power control (or other methods of fade compensation) so that when rain is not present, the transmitted power from the earth station will be reduced to a level that would provide the desired service availability.

C. Spacecraft/Network Operations Centers

The SOC will be located near the TT&C earth station and will control the spacecraft when they are on-station or nearly so. Before that, the launch, transfer orbit and early mission control of the spacecraft will be accomplished through existing facilities of the launch and spacecraft providers. The SOC will perform the well-established functions of spacecraft monitoring, planning and directing station-keeping maneuvers, preparing commands for satellite configuration changes, and handling any problems that arise during the satellite lifetimes.

The NOC will generally be associated with hub earth stations. However, at the beginning of operations of the Rainbow Ka System, one NOC may direct the network connections of several hubs. The NOC perform a variety of customer care functions as well as monitor and control the interface between the satellite system and the terrestrial network.

^{7/} Rain attenuation estimates for this application were calculated using ITU Recommendation P.618-7.

^{8/} The Commission recently released an NPRM to reexamine its rules on this subject. *See Proposed Changes in the Commission's Rules Regarding Human Exposure to Radiofrequency Electromagnetic Fields*, ET Docket No. 03-137, *Notice of Proposed Rulemaking*, FCC 03-132 (rel. June 26, 2003).

^{9/} *See* 47 CFR § 25.204(g).

VI. SPECTRUM SHARING CONSIDERATIONS

As described earlier herein, the Rainbow Ka System will employ the bands 18.3-18.8 GHz and 19.7-20.2 GHz for space-to-Earth links and 28.35-28.6 GHz and 29.25-30.0 GHz for its Earth-to-space links. There are several sharing issues associated with the use of these bands, as described below. It is endeavored to show herein that the Rainbow Ka System can equitably share the spectrum with all other authorized users. In addition, Rainbow hereby states it will cooperate with all other co-Primary users of its requested spectrum to secure equitable sharing.

A. Sharing with the Fixed, Earth Exploration and Space Research Services

There are a number of footnotes in the Tables of Allocation of both the ITU and FCC Rules that either directly or indirectly include restrictions to the use of the frequency bands employed by the Rainbow Ka System. These restrictions are intended to assist sharing with other co-Primary services in the bands. The Rules of the FCC (Part 25) also include a number of restrictions to the use of these bands in order to assist spectrum sharing. The Rainbow Ka System has been designed and will be operated so as to meet all these sometimes unharmonious restrictions.

One of these FCC restrictions is the PFD limit of §25.208(c) for the band 18.3-18.8 GHz. All the space-to-Earth transmissions of the Rainbow Ka System will meet the Power Flux Density (PFD) limits prescribed by §25.208(c), as well as the PFD limit in §25.208(d) for Earth Exploration and Space Research sharing. Table 6.1 below lists the PFD levels of the transmissions in user beams for major CONUS cities with low elevation angles, as well as for a hypothetical location (Xanadu) where the elevation angle is 0.1° (note that the Rainbow Ka System will not direct any spot beam at locations creating low elevation angles at beam center).

TABLE 6-1

	<u>Boston</u>		<u>Seattle</u>		<u>Xanadu</u>
Sat. Orbit Longitude (°W.L.)	71	119	71	119	X
Elevation angle	41.1	21.6	16.6	35.2	0.1
PFD (dBW/m ² /MHz)	-121.0	-121.3	-121.4	-121.0	-121.8
Limit of §25.208(c) (dBW/m ² /MHz)	-105.0	-106.7	-109.2	-105.0	-115.0
Margin (dB)	16.0	14.6	12.2	16.0	6.8

It should be noted that the space-to-Earth transmissions of the Rainbow Ka satellites will also meet the requirement for blanket licensing of earth stations in the band 19.7-20.2 GHz of §25.138(a)(6) that the PFD at the Earth's surface not exceed $-118 \text{ dBW/m}^2/\text{MHz}$.

It is recognized that neither the ITU^{10/} PFD limits nor those of the FCC, except for blanket licensing of Ka-band earth stations, apply to the 19.7-20.2 GHz band. However, an ITU limit does apply to the 18.3-18.8 GHz band. Table 6.1 illustrates the Rainbow Ka System should create no detrimental interference to the stations of the Fixed Service, Space Research Service or Earth Exploration-Satellite Service.

The band 18.6-18.8 GHz in the ITU and U.S. Tables of Allocations^{11/} is also allocated on a co-Primary basis for the Space Research and Earth Exploration-Satellite Services (Passive) in the space-to-Earth direction. Footnote US255 to that allocation and §25.208(d) requires that for FSS satellites the PFD not exceed -95 dBW/m^2 "across the 200 MHz band." This equates to $-118 \text{ dBW/m}^2/\text{MHz}$, which the Rainbow Ka System clearly meets, as shown above.

B. Sharing With Co-Frequency FSS Space Stations

Par. 25.140(b)(2) of the FCC Rules states:

[Each applicant must provide the following information:]

(2) An interference analysis to demonstrate the compatibility of its proposed system 2 degrees from any authorized space station. An applicant should provide details of its proposed r.f. carriers which it believes should be taken into account in this analysis. At a minimum, the applicant must include, for each type of r.f.

^{10/} Table 21-4 of RR 21.16

^{11/} See 47 CFR § 2.106.

carrier, the link noise budget, modulation parameters, and overall link performance analysis.

This Rainbow Ka application fulfills the minimum requirement of §25.140(b)(2) since representative link parameters and performances are provided in Attachment A. Moreover, it will be virtually impossible to provide an indisputable demonstration of compliance with the Commission's two-degree spacing rule, because the Ka-band FSS licensing situation in the portions of the GSO arc being applied for by Rainbow are uncertain and unsettled. One of the most obvious uncertainties is that the U.S. government has co-Primary status for its FSS satellites in the band 18.3-20.2 GHz in the portions of the arc requested by this application. Little information is available about these satellites in unclassified forums. In addition, at this time it is difficult to determine what type of Commission licensed satellite will be the neighbors of the Rainbow Ka System.

Despite these problems, it is endeavored below to show how the Rainbow Ka System will not cause unacceptable interference to potential neighbors in a two-degree spacing environment.

B.1. Interference in the space-to-Earth Direction

The U.S. government satellites in this band are required to meet virtually the same PFD limits as those licensed by the Commission.^{12/} Given the earth station antenna sidelobe parameter limits of §25.209 that Commission licensees must adhere to, and the PFD information about the Rainbow Ka satellites in Table 6.1, it is highly unlikely that in a two-degree spacing environment the Rainbow Ka System will cause unacceptable interference to nearby satellites.

B.2. Interference in the Earth-to-space Direction

A transmitting earth station meeting the requirement of §25.209 will have antenna sidelobe gain performance of:

$$29-25 \log ?$$

where: ? is the angle in degrees from the axis of the main lobe.

The smallest VSAT antenna being considered for the Rainbow Ka System will be 65 cm. in diameter. The off-axis EIRP level toward a satellite two degrees away (considering the topographic angle) will be about 3 dBW/40 kHz^{13/} which is far below the limit of $18.5-25 \log ? -10 \log (N)$ dBW/40 kHz (which is about 10 dBW/40 kHz) in §25.138(a)(1) permitting blanket

^{12/} See 47 CFR § 2.106, Footnote U.S. 334.

^{13/} Under clear sky conditions.

licensing of Ka-band VSAT applications by the Commission. Given that most U.S. Ka-band satellite systems will attempt to obtain blanket licensing of earth stations, the off-axis EIRP of the earth stations in the Rainbow Ka System should act to ensure conformity to the two-degree spacing rule.

C. Sharing with MSS Feederlinks

Section 25.258 of the Commission's Rules deals with the sharing of the subband 29.25-29.5 GHz^{14/} between the GSO FSS and NGSO MSS feederlink stations. There are several facts that should be noted:

- The subband is to be used only for hub uplinks in the Rainbow Ka system.
- Currently there are no NGSO MSS systems employing this subband that are licensed by the Commission.
- As required by Section 25.258, Rainbow will cooperate fully with any entity licensed to utilize the 29.25-29.5 GHz subband for NGSO MSS feederlinks.

^{14/} It should be noted that Section 2.106, the Commission's Allocation Table, does not specifically state that NGSO MSS feederlink stations have co-primary status.

APPENDIX A

Link Budgets for the Rainbow Ka System

Foreward

1. There are two types of link budgets in this Attachment. They are forward links (hub to user) and return links (users to hub). Both types of links were evaluated for both orbit locations for cities on the East and West Coasts in order to illustrate performance at the extremes of elevation angles.
2. The predictions for rain attenuation at 99.7% annual availability were calculated using ITU-R-P.817-6 and for gaseous attenuation using ITU-R-P.676-5.
3. The user terminals in the link budgets employ 65 cm. diameter antennas and the hub terminals 3.5 meter diameter antennas. Uplink power control was employed in both types of terminals to mitigate rain attenuation and maintain moderate power at other times. All earth stations and their antennas in the Rainbow Ka System will meet the off-axis EIRP (§25.138) and other requirements of the Commission.
4. The user return links illustrate performance of a T-1 bit rate (1.544 bps) signal with now-conventional coding techniques.

San Francisco from 119 WL**Return Link : Consumer to Hub**

		Clear	Rain- up	Rain- down	Rain- both
<u>Uplink at 30 GHz</u>					
VSAT EIRP (65 cm. antenna)	dBW	39.7	42.7	39.7	42.7
Transmit antenna pointing loss	dB	-0.5	-0.5	-0.5	-0.5
Path loss	dB	-213.4	-213.4	-213.4	-213.4
Atmospheric loss	dB	-0.4	-0.4	-0.4	-0.4
Rain loss	dB	0.0	-5.4	0.0	-5.4
Sat receive antenna gain	dB	53.60	53.60	53.60	53.60
Edge of coverage loss	dB	-8.00	-8.00	-8.00	-8.00
Received power	dBW	-129.02	-131.41	-129.02	-131.41
Data rate	dB-Hz	61.88	61.88	61.88	61.88
Eb	dBW/Hz	-190.89	-193.28	-190.89	-193.28
No (thermal)	dBW/Hz	-198.12	-198.12	-198.12	-198.12
Uplink Eb/No	dB	7.2	4.8	7.2	4.8
<u>Downlink at 20.2 GHz</u>					
Satellite EIRP - backed-off	dBW	61.4	61.4	61.4	61.4
Bandwidth split		280.0	280.0	280.0	280.0
Coverage loss @ hub	dB	-2.5	-2.5	-2.5	-2.5
Path loss	dB	-210.0	-210.0	-210.0	-210.0
Atmospheric loss	dB	-0.44	-0.44	-0.44	-0.44
Rain loss	dB	0.00	0.00	-2.40	-2.40
E.S pointing loss	dB	-0.50	-0.50	-0.50	-0.50
E.S. receive antenna gain	dB	55.17	55.17	55.17	55.17
Received power	dBW	-121.4	-121.4	-123.8	-123.8
Data rate	dB-Hz	61.88	61.88	61.88	61.88
Eb	dBW/Hz	-183.23	-183.23	-185.63	-185.63
No (thermal)	dBW/Hz	-205.62	-205.62	-204.30	-204.30
Downlink Eb/No (thermal)	dB	22.4	22.4	18.7	18.7
Downlink Eb/No (interbeam)	dB	24.0	24.0	24.0	24.0
Downlink Eb/(No+Io)	dB	20.1	20.1	17.6	17.6
<u>Totals</u>					
Uplink Eb/No	dB	7.23	4.84	7.23	4.84
Downlink Eb/(No+Io)	dB	20.11	20.11	17.55	17.55
Intersystem C/I	dB	17.00	17.00	17.00	17.00
<u>Total Eb/(No+Io)</u>	dB	6.60	4.46	6.44	4.37
<u>Required Eb/No</u>	dB	2.43	2.43	2.43	2.43
<u>Margin</u>	dB	4.17	2.03	4.01	1.94

San Francisco from 71 WL**Return Link : Consumer to Hub**

		Clear	Rain- up	Rain- down	Rain- both
<u>Uplink at 30 GHz</u>					
VSAT EIRP (65 cm. antenna)	dBW	39.7	45.7	39.7	45.7
Transmit antenna pointing loss	dB	-0.5	-0.5	-0.5	-0.5
Path loss	dB	-213.9	-213.9	-213.9	-213.9
Atmospheric loss	dB	-0.7	-0.7	-0.7	-0.7
Rain loss	dB	0.0	-7.6	0.0	-7.6
Sat receive antenna gain	dB	53.60	53.60	53.60	53.60
Edge of coverage loss	dB	-8.00	-8.00	-8.00	-8.00
Received power	dBW	-129.85	-131.43	-129.85	-131.43
Data rate	dB-Hz	61.88	61.88	61.88	61.88
Eb	dBW/Hz	-191.72	-193.30	-191.72	-193.30
No (thermal)	dBW/Hz	-198.12	-198.12	-198.12	-198.12
Uplink Eb/No	dB	6.4	4.8	6.4	4.8
<u>Downlink at 20.2 GHz</u>					
Satellite EIRP - backed-off	dBW	61.4	61.4	61.4	61.4
Bandwidth split		280.0	280.0	280.0	280.0
Coverage loss @ hub	dB	-2.5	-2.5	-2.5	-2.5
Path loss	dB	-210.5	-210.5	-210.5	-210.5
Atmospheric loss	dB	-0.87	-0.87	-0.87	-0.87
Rain loss	dB	0.00	0.00	-3.50	-3.50
E.S pointing loss	dB	-0.50	-0.50	-0.50	-0.50
E.S. receive antenna gain	dB	55.17	55.17	55.17	55.17
Received power	dBW	-122.3	-122.3	-125.8	-125.8
Data rate	dB-Hz	61.88	61.88	61.88	61.88
Eb	dBW/Hz	-184.13	-184.13	-187.63	-187.63
No (thermal)	dBW/Hz	-205.60	-205.60	-203.88	-203.88
Downlink Eb/No (thermal)	dB	21.5	21.5	16.2	16.2
Downlink Eb/lo (interbeam)	dB	24.0	24.0	24.0	24.0
Downlink Eb/(No+lo)	dB	19.5	19.5	15.6	15.6
<u>Totals</u>					
Uplink Eb/No	dB	6.40	4.82	6.40	4.82
Downlink Eb/(No+lo)	dB	19.54	19.54	15.57	15.57
Intersystem C/I	dB	17.00	17.00	17.00	17.00
<u>Total Eb/(No+lo)</u>	dB	5.85	4.43	5.58	4.23
<u>Required Eb/No</u>	dB	2.43	2.43	2.43	2.43
<u>Margin</u>	dB	3.42	2.00	3.15	1.80

New York from 119 WL**Return Link : Consumer to Hub**

		Clear	Rain- up	Rain- down	Rain- both
<u>Uplink at 30 GHz</u>					
VSAT EIRP (65 cm. antenna)	dBW	39.7	49.7	39.7	49.7
Transmit antenna pointing loss	dB	-0.5	-0.5	-0.5	-0.5
Path loss	dB	-213.8	-213.8	-213.8	-213.8
Atmospheric loss	dB	-0.7	-0.7	-0.7	-0.7
Rain loss	dB	0.0	-10.8	0.0	-10.8
Sat receive antenna gain	dB	53.60	53.60	53.60	53.60
Edge of coverage loss	dB	-8.00	-8.00	-8.00	-8.00
Received power	dBW	-129.70	-130.47	-129.70	-130.47
Data rate	dB-Hz	61.88	61.88	61.88	61.88
Eb	dBW/Hz	-191.58	-192.35	-191.58	-192.35
No (thermal)	dBW/Hz	-198.12	-198.12	-198.12	-198.12
Uplink Eb/No	dB	6.5	5.8	6.5	5.8
<u>Downlink at 20.2 GHz</u>					
Satellite EIRP - backed-off	dBW	61.4	61.4	61.4	61.4
Bandwidth split		280	280	280	280
Coverage loss @ hub	dB	-2.5	-2.5	-2.5	-2.5
Path loss	dB	-210.0	-210.0	-210.0	-210.0
Atmospheric loss	dB	-0.77	-0.77	-0.77	-0.77
Rain loss	dB	0.00	0.00	-5.00	-5.00
Hub E.S pointing loss	dB	-0.50	-0.50	-0.50	-0.50
Hub E.S. receive antenna gain	dB	55.17	55.17	55.17	55.17
Received power	dBW	-121.7	-121.7	-126.7	-126.7
Data rate	dB-Hz	61.88	61.88	61.88	61.88
Eb	dBW/Hz	-183.61	-183.61	-188.61	-188.61
No (thermal)	dBW/Hz	-205.60	-205.60	-203.60	-203.60
Downlink Eb/No (thermal)	dB	22.0	22.0	15.0	15.0
Downlink Eb/lo (interbeam)	dB	24.0	24.0	24.0	24.0
Downlink Eb/(No+lo)	dB	19.9	19.9	14.5	14.5
<u>Totals</u>					
Uplink Eb/No	dB	6.55	5.78	6.55	5.78
Downlink Eb/(No+lo)	dB	19.87	19.87	14.47	14.47
Intersystem C/I	dB	17.00	17.00	17.00	17.00
<u>Total Eb/(No+lo)</u>	dB	5.99	5.31	5.57	4.95
<u>Required Eb/No</u>	dB	2.43	2.43	2.43	2.43
<u>Margin</u>	dB	3.56	2.88	3.14	2.52

New York from 71 WL**Return Link : Consumer to Hub**

		Clear	Rain- up	Rain- down	Rain- both
<u>Uplink at 30 GHz</u>					
VSAT EIRP (65 cm. antenna)	dBW	39.7	45.7	39.7	45.7
Transmit antenna pointing loss	dB	-0.5	-0.5	-0.5	-0.5
Path loss	dB	-213.5	-213.5	-213.5	-213.5
Atmospheric loss	dB	-0.4	-0.4	-0.4	-0.4
Rain loss	dB	0.0	-8.6	0.0	-8.6
Sat receive antenna gain	dB	53.60	53.60	53.60	53.60
Edge of coverage loss	dB	-8.00	-8.00	-8.00	-8.00
Received power	dBW	-129.10	-131.64	-129.10	-131.64
Data rate	dB-Hz	61.88	61.88	61.88	61.88
Eb	dBW/Hz	-190.97	-193.52	-190.97	-193.52
No (thermal)	dBW/Hz	-198.12	-198.12	-198.12	-198.12
Uplink Eb/No	dB	7.2	4.6	7.2	4.6
<u>Downlink at 20.2 GHz</u>					
Satellite EIRP - backed-off	dBW	61.4	61.4	61.4	61.4
Bandwidth split		280	280	280	280
Beam coverage loss @ hub	dB	-2.5	-2.5	-2.5	-2.5
Path loss	dB	-210.0	-210.0	-210.0	-210.0
Atmospheric loss	dB	-0.47	-0.47	-0.47	-0.47
Rain loss	dB	0.00	0.00	-3.84	-3.84
E.S pointing loss	dB	-0.50	-0.50	-0.50	-0.50
E.S. receive antenna gain	dB	55.17	55.17	55.17	55.17
Received power	dBW	-121.4	-121.4	-125.3	-125.3
Data rate	dB-Hz	61.88	61.88	61.88	61.88
Eb	dBW/Hz	-183.31	-183.31	-187.15	-187.15
No (thermal)	dBW/Hz	-205.60	-205.60	-203.88	-203.88
Downlink Eb/No (thermal)	dB	22.3	22.3	16.7	16.7
Downlink Eb/lo (interbeam)	dB	24.0	24.0	24.0	24.0
Downlink Eb/(No+lo)	dB	20.0	20.0	16.0	16.0
<u>Totals</u>					
Uplink Eb/No	dB	7.15	4.60	7.15	4.60
Downlink Eb/(No+lo)	dB	20.05	20.05	15.98	15.98
Intersystem C/I	dB	17.00	17.00	17.00	17.00
<u>Total Eb/(No+lo)</u>	dB	6.53	4.24	6.24	4.07
<u>Required Eb/No</u>	dB	2.43	2.43	2.43	2.43
<u>Margin</u>	dB	4.10	1.81	3.81	1.64

San Francisco from 119 WL

Forward Link : Hub to Consumer

		Clear	Rain- up	Rain- down	Rain- both
<u>Uplink at 30 GHz</u>					
Gateway EIRP (3.5 m. antenna)	dBW	67.1	74.1	67.1	74.1
Transmit antenna pointing loss	dB	-0.5	-0.5	-0.5	-0.5
Path loss	dB	-213.4	-213.4	-213.4	-213.4
Atmospheric loss	dB	-0.4	-0.4	-0.4	-0.4
Rain loss	dB	0.0	-5.4	0.0	-5.4
Sat receive antenna gain	dB	53.60	53.60	53.60	53.60
Edge of coverage loss	dB	-3.00	-3.00	-3.00	-3.00
Received power	dBW	-96.60	-95.01	-96.60	-95.01
Data rate	dB-Hz	73.80	73.80	73.80	73.80
Eb	dBW/Hz	-170.40	-168.81	-170.40	-168.81
No (thermal)	dBW/Hz	-198.12	-198.12	-198.12	-198.12
Uplink Eb/No	dB	27.7	29.3	27.7	29.3
<u>Downlink at 20.2 GHz</u>					
Satellite EIRP (backed-off&split)	dBW	55.4	55.4	55.4	55.4
Edge of coverage loss	dB	-4.0	-4.0	-4.0	-4.0
Path loss	dB	-210.0	-210.0	-210.0	-210.0
Atmospheric loss	dB	-0.44	-0.44	-0.44	-0.44
Rain loss	dB	0.00	0.00	-2.40	-2.40
E.S pointing loss	dB	-0.50	-0.50	-0.50	-0.50
E.S. receive antenna gain	dB	40.76	40.76	40.76	40.76
Received power	dBW	-118.8	-118.8	-121.2	-121.2
Data rate	dB-Hz	73.80	73.80	73.80	73.80
Eb	dBW/Hz	-192.62	-192.62	-195.02	-195.02
No (thermal)	dBW/Hz	-206.62	-206.62	-204.05	-204.05
Downlink Eb/No (thermal)	dB	14.0	14.0	9.0	9.0
Downlink Eb/lo (interbeam)	dB	24.0	24.0	24.0	24.0
Downlink Eb/(No+lo)	dB	13.6	13.6	8.9	8.9
<u>Totals</u>					
Uplink Eb/No	dB	27.72	29.31	27.72	29.31
Downlink Eb/(No+lo)	dB	13.59	13.59	8.90	8.90
Intersystem C/I	dB	17.00	17.00	17.00	17.00
<u>Total Eb/(No+lo)</u>	dB	11.84	11.88	8.22	8.24
<u>Required Eb/No</u>	dB	2.43	2.43	2.43	2.43
<u>Margin</u>	dB	9.41	9.45	5.79	5.81

San Francisco from 71 WL

Forward Link : Hub to Consumer

		Clear	Rain- up	Rain- down	Rain- both
<u>Uplink at 30 GHz</u>					
Gateway EIRP (3.5 m. antenna)	dBW	67.1	74.1	67.1	74.1
Transmit antenna pointing loss	dB	-0.5	-0.5	-0.5	-0.5
Path loss	dB	-213.9	-213.9	-213.9	-213.9
Atmospheric loss	dB	-0.7	-0.7	-0.7	-0.7
Rain loss	dB	0.0	-7.6	0.0	-7.6
Sat receive antenna gain	dB	53.60	53.60	53.60	53.60
Coverage loss at hub site	dB	-3.00	-3.00	-3.00	-3.00
Received power	dBW	-97.43	-98.04	-97.43	-98.04
Data rate	dB-Hz	73.80	73.80	73.80	73.80
Eb	dBW/Hz	-171.23	-171.84	-171.23	-171.84
No (thermal)	dBW/Hz	-198.12	-198.12	-198.12	-198.12
Uplink Eb/No	dB	26.9	26.3	26.9	26.3
<u>Downlink at 20.2 GHz</u>					
Satellite EIRP (backed-off&split)	dBW	55.4	55.4	55.4	55.4
Coverage loss near edge	dB	-4.0	-4.0	-4.0	-4.0
Path loss	dB	-210.5	-210.5	-210.5	-210.5
Atmospheric loss	dB	-0.87	-0.87	-0.87	-0.87
Rain loss	dB	0.00	0.00	-3.50	-3.50
E.S pointing loss	dB	-0.50	-0.50	-0.50	-0.50
E.S. receive antenna gain	dB	40.76	40.76	40.76	40.76
Received power	dBW	-119.7	-119.7	-123.2	-123.2
Data rate	dB-Hz	73.80	73.80	73.80	73.80
Eb	dBW/Hz	-193.51	-193.51	-197.01	-197.01
No (thermal)	dBW/Hz	-206.62	-206.62	-204.05	-204.05
Downlink Eb/No (thermal)	dB	13.1	13.1	7.0	7.0
Downlink Eb/lo (interbeam)	dB	24.0	24.0	24.0	24.0
Downlink Eb/(No+lo)	dB	12.8	12.8	6.9	6.9
<u>Totals</u>					
Uplink Eb/No	dB	26.89	26.28	26.89	26.28
Downlink Eb/(No+lo)	dB	12.76	12.76	6.95	6.95
Intersystem C/I	dB	17.00	17.00	17.00	17.00
<u>Total Eb/(No+lo)</u>	dB	11.25	11.24	6.50	6.49
<u>Required Eb/No</u>	dB	2.43	2.43	2.43	2.43
<u>Margin</u>	dB	8.82	8.81	4.07	4.06

New York from 119 WL Forward Link : Hub to Consumer

		Clear	Rain- up	Rain- down	Rain- both
<u>Uplink at 30 GHz</u>					
Gateway EIRP (3.5 m. antenna)	dBW	67.1	74.1	67.1	74.1
Transmit antenna pointing loss	dB	-0.5	-0.5	-0.5	-0.5
Path loss	dB	-213.8	-213.8	-213.8	-213.8
Atmospheric loss	dB	-0.7	-0.7	-0.7	-0.7
Rain loss	dB	0.0	-10.8	0.0	-10.8
Sat receive antenna gain	dB	53.60	53.60	53.60	53.60
Edge of coverage loss	dB	-3.00	-3.00	-3.00	-3.00
Received power	dBW	-97.28	-101.06	-97.28	-101.06
Data rate	dB-Hz	73.80	73.80	73.80	73.80
Eb	dBW/Hz	-171.08	-174.86	-171.08	-174.86
No (thermal)	dBW/Hz	-198.12	-198.12	-198.12	-198.12
Uplink Eb/No	dB	27.0	23.3	27.0	23.3
<u>Downlink at 20.2 GHz</u>					
Satellite EIRP (backed-off&split)	dBW	55.4	55.4	55.4	55.4
Edge of coverage loss	dB	-4.0	-4.0	-4.0	-4.0
Path loss	dB	-210.4	-210.4	-210.4	-210.4
Atmospheric loss	dB	-0.77	-0.77	-0.77	-0.77
Rain loss	dB	0.00	0.00	-5.00	-5.00
E.S pointing loss	dB	-0.50	-0.50	-0.50	-0.50
E.S. receive antenna gain	dB	40.76	40.76	40.76	40.76
Received power	dBW	-119.5	-119.5	-124.5	-124.5
Data rate	dB-Hz	73.80	73.80	73.80	73.80
Eb	dBW/Hz	-193.35	-193.35	-198.35	-198.35
No (thermal)	dBW/Hz	-206.62	-206.62	-204.05	-204.05
Downlink Eb/No (thermal)	dB	13.3	13.3	5.7	5.7
Downlink Eb/lo (interbeam)	dB	24.0	24.0	24.0	24.0
Downlink Eb/(No+lo)	dB	12.9	12.9	5.6	5.6
<u>Totals</u>					
Uplink Eb/No	dB	27.04	23.26	27.04	23.26
Downlink Eb/(No+lo)	dB	12.92	12.92	5.64	5.64
Intersystem C/I	dB	17.00	17.00	17.00	17.00
<u>Total Eb/(No+lo)</u>	dB	11.37	11.21	5.30	5.26
<u>Required Eb/No</u>	dB	2.43	2.43	2.43	2.43
<u>Margin</u>	dB	8.94	8.78	2.87	2.83

New York from 71 WL**Forward Link : Hub to Consumer**

		Clear	Rain- up	Rain- down	Rain- both
<u>Uplink at 30 GHz</u>					
Gateway EIRP (3.5 m. antenna)	dBW	67.1	74.1	67.1	74.1
Transmit antenna pointing loss	dB	-0.5	-0.5	-0.5	-0.5
Path loss	dB	-213.5	-213.5	-213.5	-213.5
Atmospheric loss	dB	-0.4	-0.4	-0.4	-0.4
Rain loss	dB	0.0	-8.6	0.0	-8.6
Sat receive antenna gain	dB	53.60	53.60	53.60	53.60
Coverage loss at hub site	dB	-3.00	-3.00	-3.00	-3.00
Received power	dBW	-96.67	-98.25	-96.67	-98.25
Data rate	dB-Hz	73.80	73.80	73.80	73.80
Eb	dBW/Hz	-170.48	-172.06	-170.48	-172.06
No (thermal)	dBW/Hz	-198.12	-198.12	-198.12	-198.12
Uplink Eb/No	dB	27.6	26.1	27.6	26.1
<u>Downlink at 20.2 GHz</u>					
Satellite EIRP (backed-off&split)	dBW	55.4	55.4	55.4	55.4
Coverage loss near edge	dB	-4.0	-4.0	-4.0	-4.0
Path loss	dB	-210.0	-210.0	-210.0	-210.0
Atmospheric loss	dB	-0.47	-0.47	-0.47	-0.47
Rain loss	dB	0.00	0.00	-3.84	-3.84
E.S pointing loss	dB	-0.50	-0.50	-0.50	-0.50
E.S. receive antenna gain	dB	40.76	40.76	40.76	40.76
Received power	dBW	-118.9	-118.9	-122.7	-122.7
Data rate	dB-Hz	73.80	73.80	73.80	73.80
Eb	dBW/Hz	-192.70	-192.70	-196.54	-196.54
No (thermal)	dBW/Hz	-206.62	-206.62	-204.05	-204.05
Downlink Eb/No (thermal)	dB	13.9	13.9	7.5	7.5
Downlink Eb/lo (interbeam)	dB	24.0	24.0	24.0	24.0
Downlink Eb/(No+lo)	dB	13.5	13.5	7.4	7.4
<u>Totals</u>					
Uplink Eb/No	dB	27.65	26.07	27.65	26.07
Downlink Eb/(No+lo)	dB	13.51	13.51	7.41	7.41
Intersystem C/I	dB	17.00	17.00	17.00	17.00
<u>Total Eb/(No+lo)</u>	dB	11.79	11.74	6.92	6.91
<u>Required Eb/No</u>	dB	2.43	2.43	2.43	2.43
<u>Margin</u>	dB	9.36	9.31	4.49	4.48