



Wiley Rein & Fielding LLP

ORIGINAL

EX PARTE OR LATE FILED

1776 K STREET NW
WASHINGTON, DC 20006
PHONE 202.719.7000
FAX 202.719.7049

Virginia Office
7925 JONES BRANCH DRIVE
SUITE 6200
McLEAN, VA 22102
PHONE 703.905.2800
FAX 703.905.2820

www.wrf.com

October 29, 2003

Tricia Paoletta
202.719.7532
tpaoletta@wrf.com

RECEIVED

OCT 29 2003

Ms. Marlene H. Dortch, Secretary
Federal Communications Commission
236 Massachusetts Avenue, N.E., Suite 1100
Washington, DC 20002
~~FEDERAL COMMUNICATIONS COMMISSION~~
OFFICE OF THE SECRETARY

Re: Ex Parte Presentation; Final Analysis Communication Services, Inc.
Amendment to Petition for Waiver and Modification to Extend Milestones
(filed June 6, 2003); Petition for Waiver (filed Mar. 29, 2002); File Nos.
SAT-LOA-19941116-00088; SAT-AMD-19950224-00033; SAT-AMD-
19960223-00031; SAT-AMD-19960819-00107; SAT-AMD-19971030-
00175; SAT-MOD-20020329-00245

Dear Ms. Dortch:

On behalf of New York Satellite Industries, LLC ("NYS"), I am filing this notice of an *ex parte* communication with officials of the Satellite Division, including Thomas Tycz, Chief, Cassandra Thomas, Deputy Chief, Marcus Wolf, Mark Young, and Sankar Persaud on October 29, 2003 discussing the above-referenced application.¹ New York Satellite Industries, LLC ("NYS") was represented by Nader Modanlo, Managing Member, and Patricia Paoletta and Carl Frank of Wiley Rein & Fielding LLP, as counsel. NYS' subsidiary and FCC licensee, Final Analysis Communication Services, Inc. ("FACS"), was represented by Jan Friis and Robert Crenshaw of FACS and Randy Sifers of Kelly Drye, as counsel.

The purpose of the meeting was to request the status and possible timing of action on FACS' extension request filed in June 2003. FACS reiterated its interest in a Bureau decision in the near-term, to facilitate continued momentum on system development. FACS also updated the Division on developments, including FACS' coordination efforts with federal agencies and FACS' participation in study groups relating to Resolution 745 from WRC-03. Attached hereto are the text of Resolution 745 and several contributions related to the compatibility studies called for in the Resolution, on which FACS has been actively engaged. In addition, FACS apprised the Division of the positive developments in a civil lawsuit in the State of Maryland involving FACS.

No. of Copies rec'd
List APCDE

OH

¹ 47 C.F.R. §1.1206.

Ms. Marlene H. Dortch, Secretary
October 29, 2003
Page 2

Please do not hesitate to contact the undersigned with any questions.

Sincerely,

A handwritten signature in black ink, appearing to read 'Tricia Paoletta', with a long horizontal flourish extending to the right.

Tricia Paoletta

cc: w/attachment: Sheryl Wilkerson
Jennifer Manner
Sam Feder
Paul Margie
Barry Ohlson
Don Abelson
Tom Tycz
Jackie Ruff
Cassandra Thomas
Karl Kensinger
Mark Young
Sankar Persaud

WRC-03 Resolution 745

“Protection of Existing Services in all Regions from Non-Geostationary-Satellite Networks in the Fixed-Satellite Service using the Frequency Bands around 1.4 GHz on a Secondary Basis”

The Study Program

Relevant Studies in Progress

Contents

- WRC-03 Resolution 745 (COM5/14): "Protection of existing services in all Regions from non-geostationary-satellite networks in the fixed-satellite service using the frequency bands around 1.4 GHz on a secondary basis."
- Document WP 7C-8: USA: Working Document Towards A Preliminary Draft New Recommendation "Protection of EESS (passive sensors in the band 1 400 –1 400 MHz from MSS feeder links that operate in the FSS around 1 400 MHz" (September 25, 2003)
- Document WP 7C/15 and 7D/5: France: "Protection of the Radio Astronomy and Earth Exploration (Passive) Space Services operating in the band 1400-1420 MHz from unwanted emissions of MSS feeder links operating in the band 1430-1432 MHz" (October 2, 2003)
- Document WP 7C/16: France: "Protection of the Earth Exploration (Passive) Space Service Operating in the Band 1 400-1 420 MHz from Unwanted Emissions of MSS Feeder Links Operating in the band 1 390-1 392 MHz" (October 2, 2003)
- Document US WP 8D/7 rev 1: USA: "Results of Tests, Measurements and Studies Pertaining to Containment of Unwanted Emissions in Response to Resolution 745" (October 14, 2003)

RESOLUTION [COM5/14] (WRC-03)

Protection of existing services in all Regions from non-geostationary-satellite networks in the fixed-satellite service using the frequency bands around 1.4 GHz on a secondary basis

The World Radiocommunication Conference (Geneva, 2003),

considering

- a)* that the agenda of this Conference included consideration of the adoption of allocations for feeder links for the non-geostationary (non-GSO) systems in the mobile-satellite service (MSS) around 1.4 GHz;
- b)* that the band 1 350-1 400 MHz is allocated on a primary basis to the radiolocation, fixed and mobile services in Region 1 and to the radiolocation service in Regions 2 and 3;
- c)* that Nos. **5.149**, **5.338** and **5.339** also apply to the band 1 350-1 400 MHz;
- d)* that the band 1 400-1 427 MHz is allocated to the Earth exploration-satellite service (EESS) (passive), radio astronomy and space research (passive) services on a primary basis in all Regions;
- e)* that No. **5.340** also applies to the band 1 400-1 427 MHz;
- f)* that the band 1 427-1 429 MHz is allocated in all Regions to the space operation (Earth-to-space), fixed and mobile (except aeronautical mobile) services on a primary basis;
- g)* that No. **5.341** also applies to the band 1 400-1 452 MHz;

h) that the band 1 429-1 452 MHz is allocated on a primary basis to the fixed service in all Regions, to the mobile service (except aeronautical mobile) in Region 1 and to the mobile service in Regions 2 and 3;

i) that No. 5.342 also applies to the band 1 429-1 452 MHz in Region 1;

j) that the Report of the 2002 Conference Preparatory Meeting (CPM-02) indicated that there were significant technical challenges to be overcome in some areas if existing services, particularly passive services, were to be protected from harmful interference from the operation of feeder links around 1.4 GHz;

k) that the Report of CPM-02 also indicated that studies in ITU-R were incomplete for the radio astronomy, EESS (passive), space research, aeronautical mobile (aeronautical mobile telemetry (AMT)) and radiolocation services,

recognizing

that secondary allocations around 1.4 GHz to the fixed-satellite service (FSS) for feeder links for non-GSO satellite systems in the MSS with service links below 1 GHz may support the development of new services on a global basis,

resolves

1 that the additional allocations for the FSS on a secondary basis in the bands 1 390-1 392 MHz and 1 430-1 432 MHz for feeder links in the (Earth-to space) and (space-to-Earth) directions, respectively, for non-GSO satellite systems in the MSS with service links operating below 1 GHz, shall not be used until the completion of ITU-R studies on all identified compatibility issues as shown in Annex 1 to this Resolution and the results of these studies shall be reported to WRC-07 and the decisions should be taken by WRC-07 accordingly;

2 to recommend that decisions taken by WRC-07, including any provisions for the protection of other services to which the bands in *resolves* 1 are allocated, and of passive services in the adjacent band, apply to all non-GSO FSS systems in these bands filed to the Bureau after 5 July 2003,

further resolves to invite ITU-R, as a matter of urgency

1 to continue studies, and to carry out tests and demonstrations to validate the studies on operational and technical means to facilitate sharing around 1.4 GHz, including the frequency band 1 390-1 392 MHz, between existing and currently planned services and FSS feeder links (Earth-to-space) for use by non-GSO satellite systems in the MSS with service links operating below 1 GHz;

2 to conduct studies and carry out tests and demonstrations to validate the studies on operational and technical means to facilitate sharing around 1.4 GHz, including the frequency band 1 430-1 432 MHz, between existing and currently planned services and FSS feeder links (space-to-Earth) for use by non-GSO satellite systems in the MSS with service links operating below 1 GHz;

3 to carry out studies, including the measurement of emissions from equipment that would be employed in operational systems, to validate that the systems meet all

requirements for the protection of passive services in the band 1 400-1 427 MHz from unwanted emissions from FSS feeder links around 1.4 GHz for non-GSO satellite systems in the MSS with service links operating below 1 GHz;

4 to study the power flux-density (pfd) values required to protect sensors of the EESS (passive) operating in the band 1 400-1 427 MHz.

ANNEX 1

Compatibility issues

Earth-to-space

Service	Parameter of concern	1 350-1 400 MHz	1 400-1 427 MHz
Fixed service		Note 1	Note 2
Mobile service		Note 1	Note 2
Radiolocation	pdf limits	Note 1	Note 2
EESS (passive) (secondary) (No. 5.339)	e.i.r.p. limits	Note 1	Note 2
Radio astronomy	pdf limits, separation distances	Note 1	Note 1
EESS (passive)	unwanted emission limits; limited filter rejection	Note 2	Note 1
Space research (passive)	pdf limits	Note 2	No issue

space-to-Earth

Service	Parameter of concern	1 350-1 400 MHz	1 400-1 427 MHz	1 429-1 452 MHz
Fixed service	pdf limits	Note 1	Note 2	Note 1
Mobile service	pdf limits; FSS shall not cause harmful interference	Note 1	Note 2	Note 1
Aeronautical mobile (AMT)	pdf limits	Note 2	Note 2	Note 1
Radio astronomy	epfd limits; issue % of time	Notes 1 and 2	Note 1	Note 2
EESS (passive)	unwanted emission limits; limited filter rejection	Note 2	Note 1	Note 2
Space research (passive)	pdf limits	Note 2	Note 1	Note 2

NOTE 1 – study considered in this Resolution

NOTE 2 – no allocation (for radio astronomy: No. 5.149 applies to the band 1 350-1 400 MHz)

ADD COM5/308/14 (B8/325/14) (R4/351/146)



Received: 24 September 2003

United States of America

WORKING DOCUMENT TOWARDS A PRELIMINARY DRAFT NEW RECOMMENDATION

Protection of EESS (passive) sensors in the band 1 400-1 427 MHz from MSS feeder links that operate in the FSS around 1 400 MHz

1 Introduction

This document is proposed as a working document intended to support the development of a new ITU-R Recommendation for use in future studies that consider the protection of Earth exploration-satellite service (EESS) (passive) sensors operating in the band 1 400-1 427 MHz from mobile-satellite service (MSS) feeder links operating around 1 400 MHz.

The 1 400-1 427 MHz band is allocated to the EESS (passive), radio astronomy service, and space research service (passive) on a primary basis. Uses of this band by EESS (passive) include remote sensing of soil moisture content and ocean salinity, and radio astronomy detection of Hydrogen in distant galaxies.

WRC-03 provided a conditional secondary allocation to non-geostationary MSS systems through footnote 5.339A which states:

“the band 1 390-1 392 MHz is also allocated to the fixed-satellite service (Earth-to-space) on a secondary basis and the band 1 430-1 432 MHz is also allocated to the fixed-satellite service (space-to-Earth) on a secondary basis. These allocations are limited to use for feeder links for non-geostationary-satellite networks in the mobile-satellite service with service links below 1 GHz, and Resolution 745 (WRC-03) applies.”

Resolution 745 provides for the protection of existing services in all Regions from non-geostationary MSS systems by stating that these band shall not be used until the completion of ITU-R studies on all identified compatibility issues and the results of these studies are reported to WRC-07, and that decisions be taken by WRC-07 accordingly. Compatibility issues that must be studied include interference to radio astronomy, EESS (passive), and SRS (passive).

Previous sharing studies concerning such MSS feeder links employed static analyses that have shown that very high out-of-band attenuation levels may be required, particularly for MSS uplinks, to protect EESS (passive) sensors. These sharing studies were contained in Document 7C/79, Document 7C/98, Document 7C/199, and Document CPM02-2/131(Add.1). This contribution describes a proposed methodology for determining the out-of-band attenuation of MSS feeder links to ensure protection of EESS (passive) sensors in the band 1 400-1 427 MHz that takes into account

the dynamic aspects of this sharing scenario. Using dynamic simulations, cumulative distribution functions (CDFs) are developed of the received co-channel interference level (i.e., probability that a particular interference level is exceeded) for a typical MSS spacecraft constellation and earth station deployment. These co-channel interference results are then used to determine the amount of out-of-band attenuation required by the MSS feeder links operating in bands adjacent to the EESS passive sensors.

2 Technical Characteristics of the EESS Passive Sensor Satellite

Frequencies near 1 400 MHz are ideal for measuring soil moisture, and also for measuring sea surface salinity and vegetation biomass. Soil moisture is a key variable in the hydrologic cycle with significant influence on evaporation, infiltration, and runoff. To date, there is no capability to measure soil moisture and sea surface salinity directly on a global basis, so the protection of this passive band is essential.

NASA is currently developing an instrument for measuring Soil Moisture (the HYDROS mission) which will collect measurements in the entire passive microwave band under consideration (1 400 to 1 427 MHz). The technical characteristics of this passive sensing satellite are presented in Table 1.

TABLE 1
HYDROS Passive Sensor Parameters

Parameter	Value
Peak Antenna Gain	35 dBi
3 dB Beamwidth	2.6°
Antenna Gain Floor	-4 dBi at ± 12° off-axis
Antenna Polarization	Horizontal and Vertical
Antenna Pointing	40° off-nadir Scanning about nadir at 6 rpm Sampling time 72 msec/cell
Orbit	670 km altitude 98° inclination
Receiver Reference Bandwidth	27 MHz
Permissible Interference Level	-174 dBW
Percentage Interference May Be Exceeded	0.1%

In addition to the normal Earth-viewing mode of HYDROS, the sensor will periodically be required to perform hot and cold calibration measurements that involve different geometries than those described below. The sensor beam pattern for the HYDROS sensor is illustrated in Figure 1. This pattern was obtained by digitizing the HYDROS pattern given in previous ITU-R documents into a table of gains versus off-axis angles for use in the simulation program.

In compliance with Recommendation ITU-R SA.1029-2, the permissible interference level for passive sensors operating in the 1 400 – 1 427 MHz band is -174 dBW in the reference bandwidth of 27 MHz. The percentage of area or time that the permissible interference level may be exceeded is 0.1%.

FIGURE 1
HYDROS Antenna Pattern

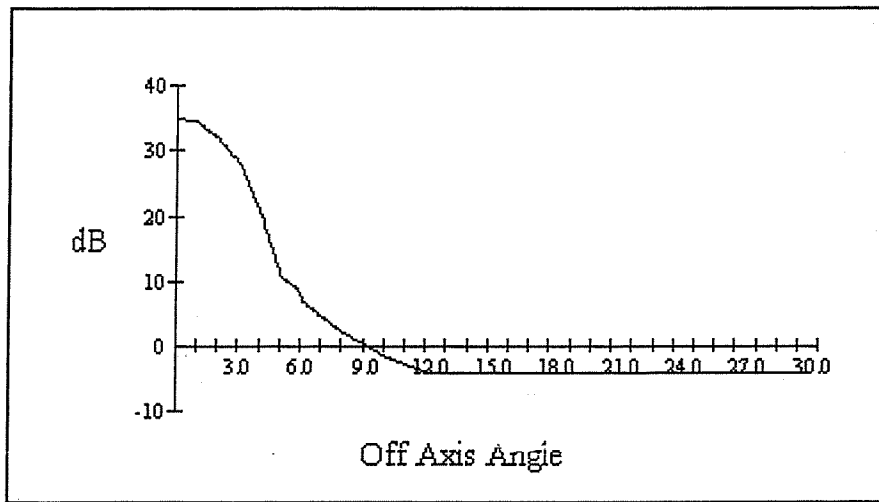

3 Technical Characteristics of the MSS System

The 1 390-1 392 MHz band and 1 430-1 432 MHz are under consideration for feeder links between non-geostationary mobile service satellites and fixed earth stations located world-wide. These feeder links transmit data to and receive data from a constellation of MSS satellites. In addition, telemetry, tracking and command functions will be carried out via these links. Table 2 provides the characteristics of the non-geostationary MSS constellation, and Table 3 provides the characteristics of the MSS earth stations. These characteristics are used for this analysis as an example MSS system implementation.

Figure 2 illustrates the gain pattern of the non-GSO MSS satellite circularly-polarized feeder-link antenna used in this analysis for both transmit and receive. The gain pattern of this MSS satellite antenna is designed to illuminate the earth with equal power for all elevation angles between 5 to 90 degrees. Figure 3 illustrates the gain pattern of the MSS earth station antenna. This pattern is taken from Appendix 8, Annex III of the Radio Regulations. Fifteen MSS earth stations were assumed for this analysis and were distributed throughout the world as shown in Figure 4.

TABLE 2
MSS Space Segment Characteristic

Parameter	Value
Total Number of Satellites	26
Altitude	1000 km
Inclination	6 planes at 66°, 4 satellites per plane 2 planes at 83°, 1 satellite per plane
Peak Antenna Gain	See Figure 2
Gain Floor	-6 dB
Antenna Polarization	Right Hand Circular
Antenna Pointing	Fixed, approx. 4 000 km diameter coverage area
Transmit Power	1 watt
Line Loss	1 dB
Satellite Bandwidth	100 kHz

TABLE 3
MSS Ground Segment Characteristics

Parameter	Value
Total Number of Earth Stations	15
Earth Station Locations	See Figure 4
Peak Gain	30 dBi
3 dB Beamwidth	5°
Gain Floor	-1.5 dBi
Antenna Pattern	RR Appendix 8, Annex III
Antenna Polarization	Right Hand Circular
Antenna Pointing	Tracks nearest satellite at elevations between 5° and 90°
Transmit Power	10 watts
Line Loss	1 dB
Earth Station Bandwidth	100 kHz

FIGURE 2
Non-GSO MSS Satellite Receive and Transmit Antenna Patterns

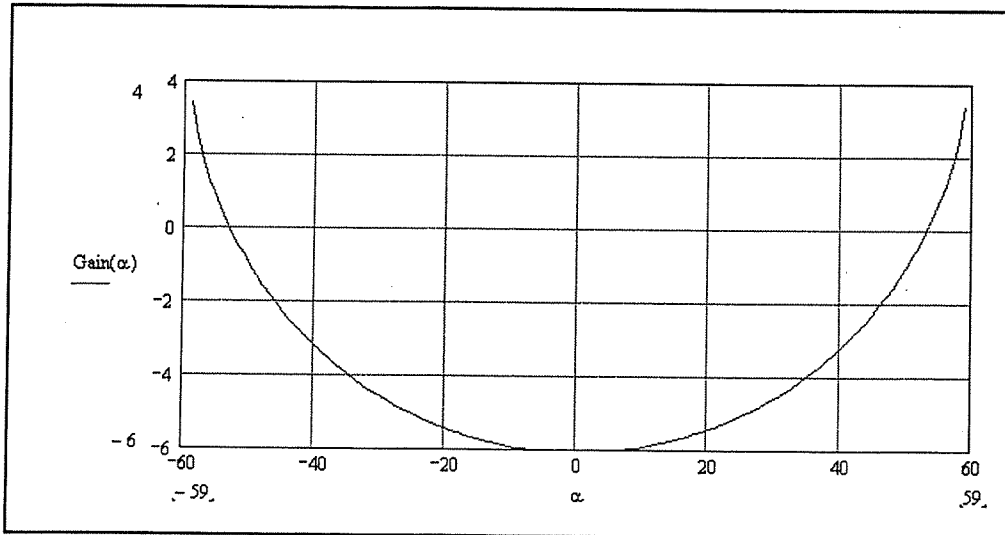

FIGURE 3
Non-GSO MSS Earth Station Receive and Transmit Antenna Patterns

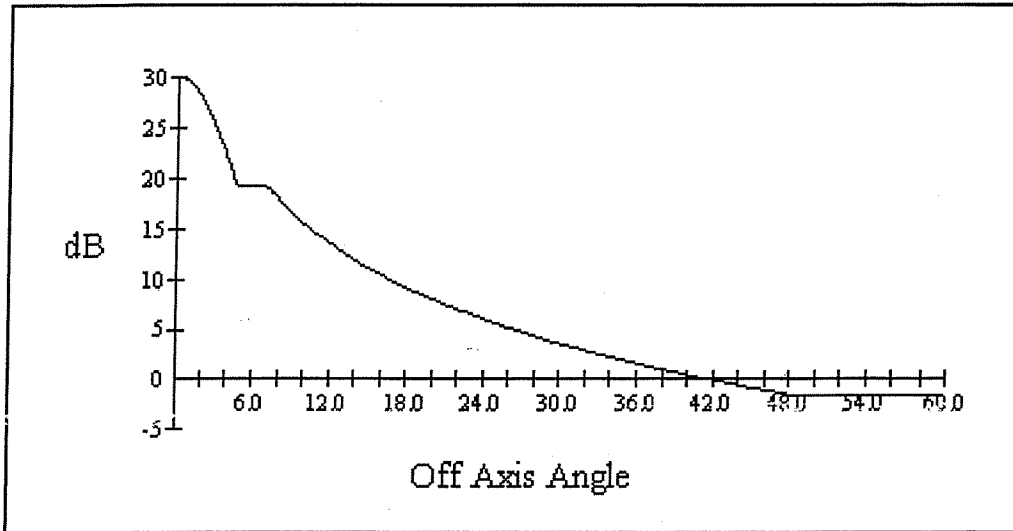
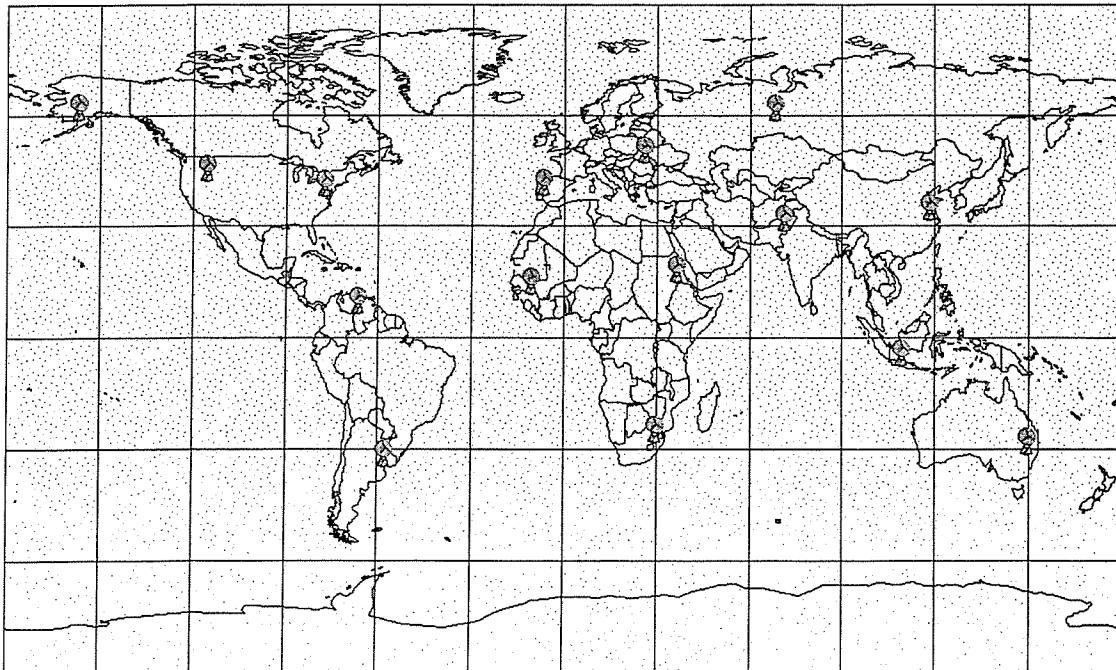

FIGURE 4
MSS Earth Station Distribution Used for Simulation



4 Interference Analysis

4.1 Overview

A dynamic interference model was developed using a commercial interference simulation tool. Interference statistics were collected for co-channel interference from MSS feeder links (uplinks and downlinks) into the spaceborne passive sensor described in Section 2. The simulation model was developed to calculate the cumulative distribution functions (CDFs) of co-channel interference power produced by an aggregate of the MSS uplinks and downlinks at the passive sensor receiver input. These co-channel interference results were then used to determine the amount of out-of-band attenuation required by the MSS feeder links operating in bands adjacent to the passive sensors based on the EESS (passive) protection criteria.

Interference statistics were also collected during each simulation run, including the worst-case interference power, the percentage of time the interference power exceeded the specified interference criteria, and the duration of the longest event exceeding the specified interference criteria.

At each step of the simulation, the model calculated the aggregate power at the output of the sensor antenna produced by all visible and active MSS uplinks and downlinks. The simulations were run in 5 msec time steps to ensure adequate overlap with the 72 msec sampling time per cell of the HYDROS sensor beam. A total of 241.92 million time steps were used in the simulations corresponding to a period of 14 days in real time.

The interference power level (I dBW) at the output of the passive sensor antenna was calculated using the following equation:

$$I = 10 \cdot \log P_t - L_i + G_t - (32.44 + 20 \cdot \log(f \cdot R)) + G_r - L_p - L_{atm}$$

where:

- P_t = interferer transmitter power (Watts);
- L_i = transmitter line loss;
- G_t = interferer antenna gain in direction of victim station (dBi);
- f = victim station receive frequency (MHz);
- R = slant range between interferer and victim station (km);
- G_r = victim station antenna gain in direction of interferer (dBi);
- L_p = polarization discrimination loss;
- L_{atm} = atmospheric absorption loss (dB).

A value of 0 dB was used for attenuation due to atmospheric absorption (dry air and water vapor). A value of 1.4 dB was used for the polarization discrimination loss resulting from a linearly polarized passive sensor antenna and a circularly polarized MSS antenna. These calculations assume that all of the MSS links operate on the same frequency and are within the passive sensor bandwidth. All simulations were performed at a frequency of 1 400 MHz.

4.2 Earth-to-Space Links

The interference scenario for the MSS earth-to space link is depicted in Figure 5. During each time step in the simulation, an MSS earth station will track the nearest MSS satellite located between elevation angles of 5 and 90 degrees. The MSS earth station uplink is active only when tracking an MSS satellite that is in view.

The calculated passive sensor co-channel interference levels at each time step were sorted into bins of 0.5 dB resolution for use in plotting the CDF. The CDF for the earth-to-space link interference power level is plotted in Figure 6. Table 4 provides simulation statistics in terms of worst case and average co-channel interference power at the passive sensor receiver, the percentage of time that the passive sensor interference threshold is exceeded (assuming no OOB attenuation), and the longest duration of an interference event that exceeded the interference criteria.

Previous static analyses indicated worst case interference levels higher than those shown in Table 4. In order to validate this simulation model, the simulation was configured to produce the worst case interference geometry (main beam-to-main beam coupling), and results were obtained consistent with the previous static analyses. However, because of the dynamic nature of the passive sensor and MSS earth station antennas, and the narrow beam width of the antennas, the worst case alignment (main beam-to-main beam coupling) occurs only during a very small percentage of time for this particular MSS system constellation and earth station deployment.

Table 5 calculates the out-of-band attenuation that the MSS uplinks will require when operating in the band adjacent to the EESS passive sensors. The first row provides the MSS uplink co-channel interference power level into the passive sensor for a 0.1% exceedance criteria. From this value, the passive sensor permissible interference level of -174 dBW for 0.1% exceedance criteria is subtracted to determine the required MSS uplink out-of-band attenuation. The calculated out-of-band attenuation level necessary to protect the HYDROS sensor is 45 dB. Previous worst case static analyses have shown that the required out-of-band attenuation level is between 108 dB and 128 dB for MSS uplinks.

FIGURE 5
Interference Scenario for MSS Earth-to-Space Link

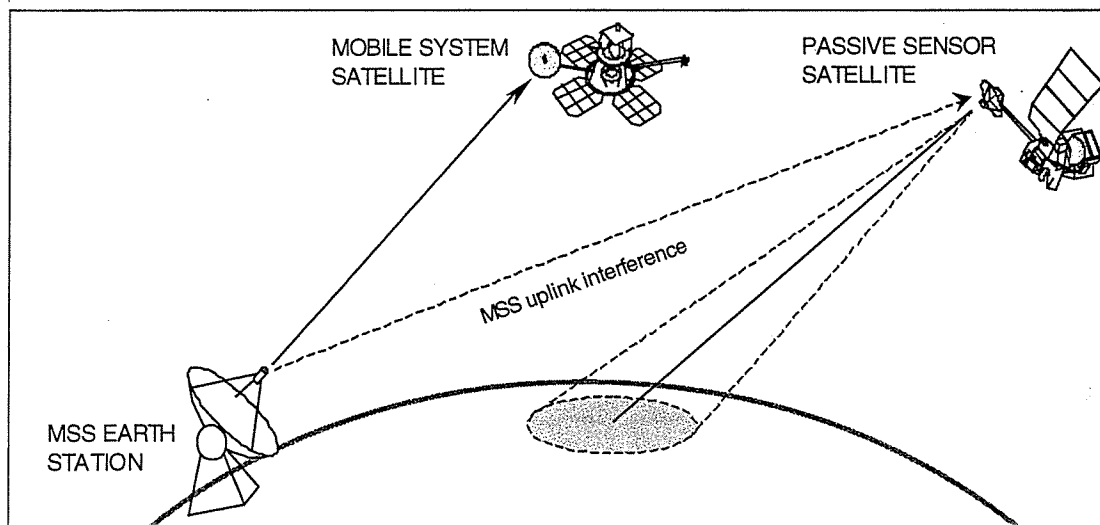

FIGURE 6

CDFs for Co-Channel Interference into Passive Sensors from MSS Uplinks

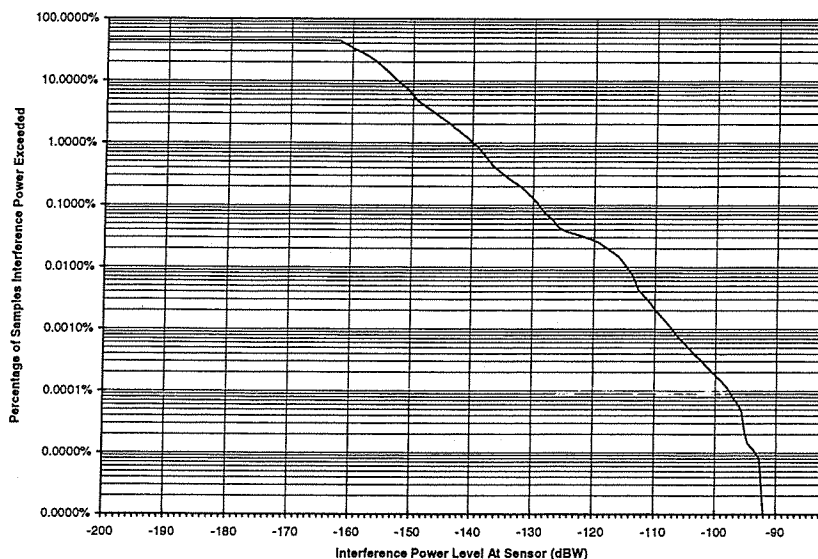

TABLE 4

Statistics on Passive Sensor Co-Channel Interference Events from MSS Uplinks

Parameter	Value
Worst case interference power	-91.93 dBW
Average interference power	-155.40 dBW
Percentage of time during which the interference threshold level was exceeded (assuming no OOB attenuation)	41.7%
Duration of longest interference event	38.3 minutes

TABLE 5

Required MSS Uplink Out-Of-Band Attenuation

Parameter	Value
MSS uplink interference power for 0.1% exceedance criteria	-129 dBW
Permissible interference level for 0.1% exceedance criteria	-174 dBW
Required OOB attenuation for MSS uplink	45 dB

4.3 Space-to-Earth Links

The two worst case interference scenarios for the MSS space-to-earth link are depicted in Figure 7. For this dynamic analysis, the aggregate interference level is calculated at the sensor receiver input from all visible MSS satellite downlinks during each time step in the simulation. The MSS satellite downlinks are assumed to be always active during the simulation.

The calculated passive sensor co-channel interference levels at each time step were sorted into bins of 0.5 dB resolution for use in plotting the CDF shown in Figure 8. Table 6 provides simulation statistics in terms of worst case and average co-channel interference power at the passive sensor receiver, and the percentage of time that the passive sensor interference threshold is exceeded (assuming no OOB attenuation).

Table 7 calculates the out-of-band attenuation that the MSS downlinks will require when operating in the band adjacent to the EESS passive sensors. The first row provides the MSS downlink co-channel interference power levels into the passive sensor for a 0.1% exceedance criteria. From this value, the passive sensor permissible interference level of -174 dBW for 0.1% exceedance criteria is subtracted to determine the required MSS downlink out-of-band attenuation. The calculated out-of-band attenuation level necessary to protect the HYDROS sensor is 21 dB.

FIGURE 7
Interference Scenarios for MSS Space-to-Earth Link

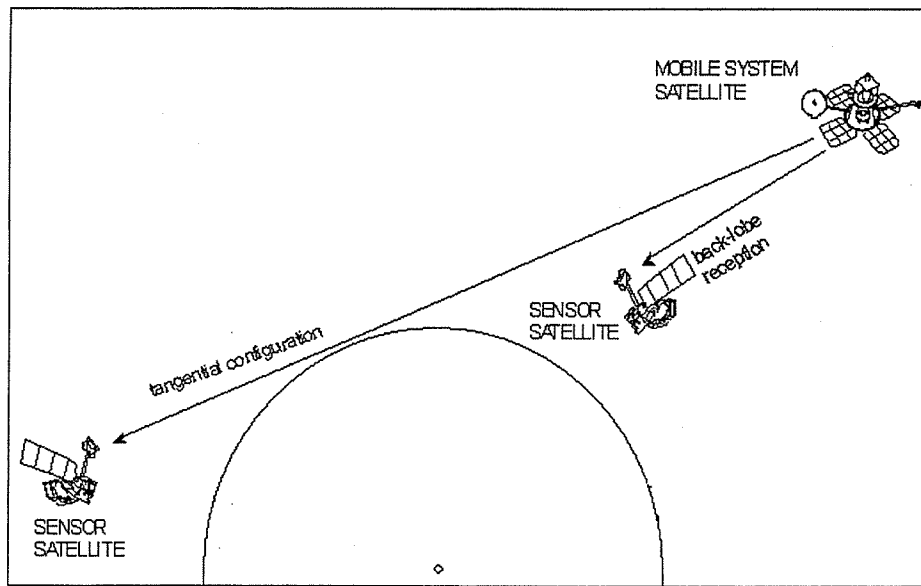

FIGURE 8

CDFs for Co-Channel Interference into Passive Sensors from MSS Downlinks

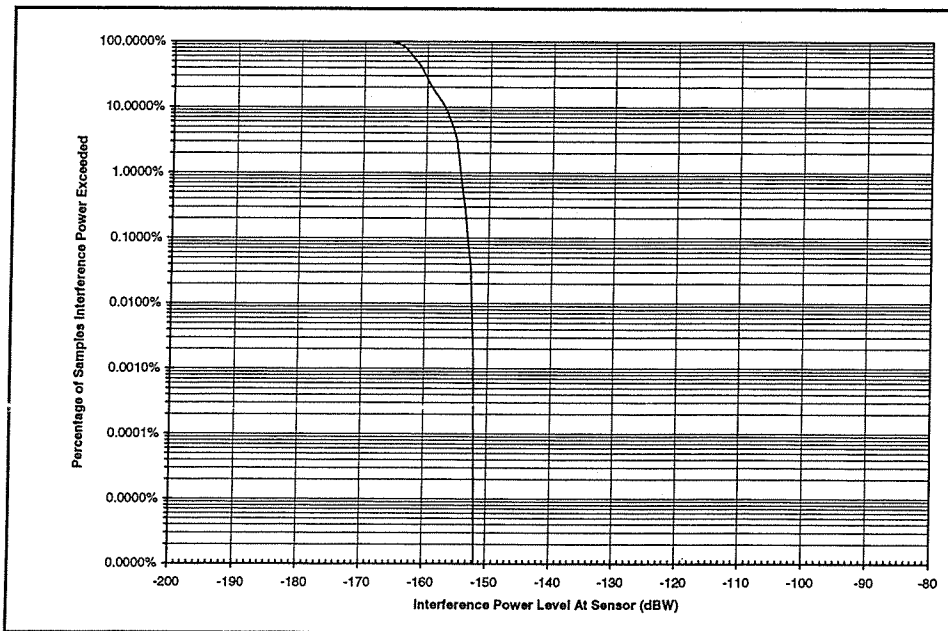

TABLE 6

Statistics on Passive Sensor Co-Channel Interference Events from MSS Downlinks

Parameter	Value
Worst case interference power	-151.96 dBW
Average interference power	-161.02 dBW
Percentage of time during which the interference threshold level was exceeded (assuming no OOB attenuation)	100%

TABLE 7

Required MSS Downlink Out-Of-Band Attenuation

Parameter	Value
MSS downlink interference power for 0.1% exceedance criteria	-153 dBW
Permissible interference level for 0.1% exceedance criteria	-174 dBW
Required OOB attenuation for MSS downlink	21 dB

5 Future Work

This document provides an example of applying a methodology to determine EESS (passive) sensor interference from one example MSS system. Additional simulations and analyses are required to address the following:

- Other planned EESS (passive) satellites operating in the 1 400-1 427 MHz band (e.g., SMOS, Aquarius).
- Interference into EESS (passive) satellites during sensor system calibration.
- Multiple MSS systems with feeder links operating near the 1 400-1 427 MHz band.
- Co-channel interference into EESS (passive) satellites operating in the band 1 370-1 400 MHz on a secondary basis under No. 5.339.
- Other sources of interference to EESS (passive) and the percentage of total interference allocated to MSS feeder links.

6 Summary and Proposal

A methodology is proposed using dynamic simulations for evaluating the compatibility between MSS feeder links and EESS (passive) sensors operating in the 1 400-1 427 MHz band. This methodology is considered a first step in evolving previous worst case static analyses to dynamic analyses that can be used to assess interference into EESS (passive) sensors vis a vis the percentage of measurement time the maximum interference level can be exceeded as given in Rec. ITU-R SA.1029-2.

It is proposed that this study be retained by WP 7C as a working document towards the studies called for by Resolution 745 (WRC-03) and to support the development of an ITU-R preliminary draft new Recommendation.

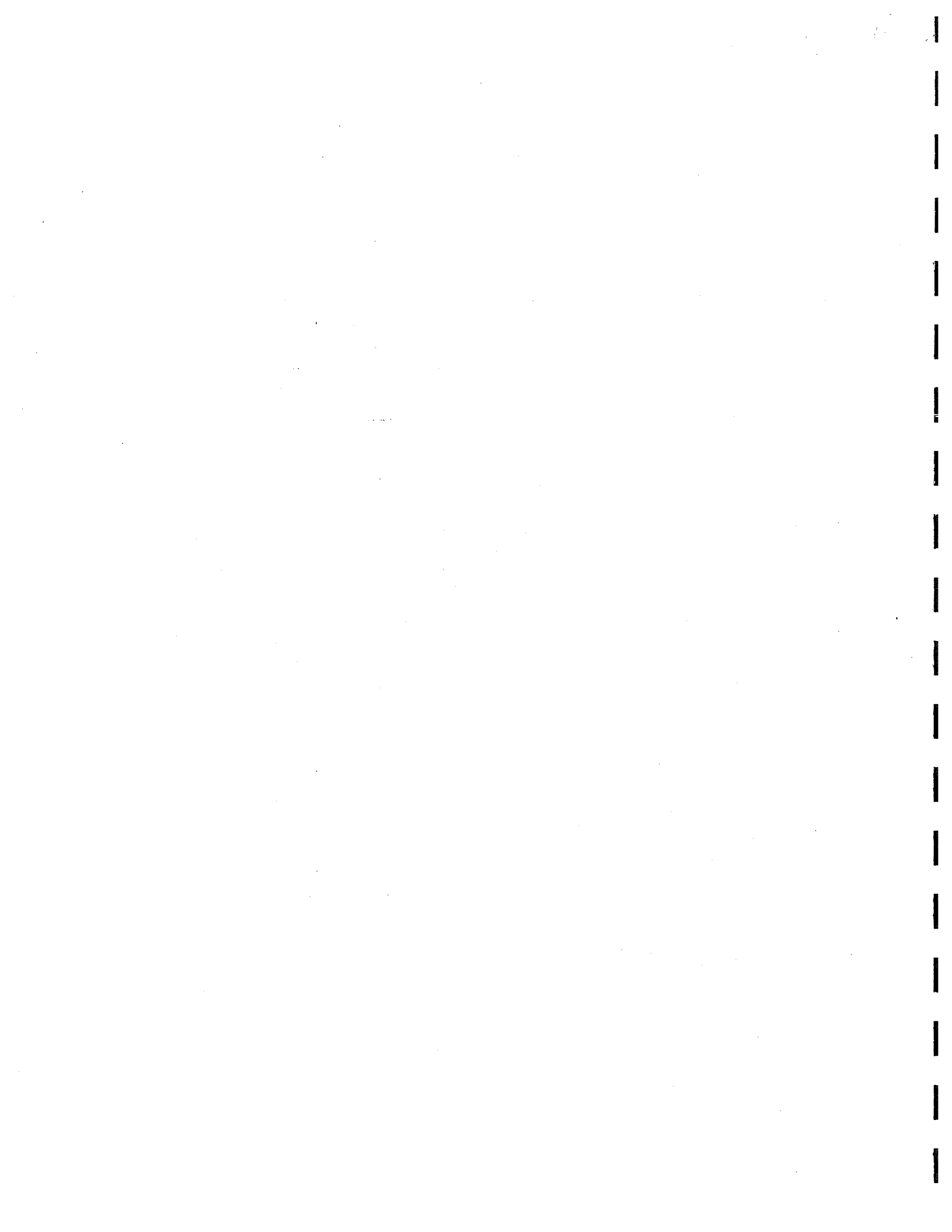



Received: 2 October 2003

France

PROTECTION OF THE RADIO ASTRONOMY AND EARTH EXPLORATION (PASSIVE) SPACE SERVICES OPERATING IN THE BAND 1 400-1 420 MHz FROM UNWANTED EMISSIONS OF MSS FEEDER LINKS OPERATING IN THE BAND 1 430-1 432 MHz

1 Introduction

WRC-03 made a secondary allocation to the FSS for MSS feeder links through No 5.339A as follows :

“5.339A *Additional allocation:* the band 1 390-1 392 MHz is also allocated to the fixed-satellite service (Earth-to-space) on a secondary basis and the band 1 430-1 432 MHz is also allocated to the fixed-satellite service (space-to-Earth) on a secondary basis. These allocations are limited to use for feeder links for non-geostationary-satellite networks in the mobile-satellite service with service links below 1 GHz, and Resolution **745 (WRC-03)** applies. (WRC-03)”

Resolution **745 (WRC-03)** states that this new allocation can not be used until all studies pertaining to sharing between FSS and other services in the allocated bands or the passive adjacent band are completed. A new agenda item (1.17) was approved for the agenda of the next conference.

The purpose of this document is to analyse the sharing conditions between the FSS (downlink), the Radioastronomy Service and the EESS, by showing that the pfd limit required to protect the Radioastronomy service is sufficient to protect the EESS (passive) from harmful interference.

2 Methodology

Recommendation ITU-R S.1586 provides a methodology to evaluate the levels of unwanted emissions produced by a non-geostationary satellite system at radio astronomy sites. It is based on a division of the sky into cells of nearly equal size and a statistical analysis where the pointing direction of the RAS antenna and the starting time of the satellite constellation are the random variables. For each trial, the unwanted emission level (expressed in terms of *epfd*) is averaged over a 2000 s period.

Moreover, Annex 1 to Recommendation ITU-R RA.769 provides the threshold levels for interference detrimental to the RAS and Recommendation ITU-R RA.1513 provides a criterion of 2% for maximum allowable data loss to the RAS due to interference from any one network, which is determined as the percentage of integration periods of 2000 s in which the average spectral power flux-density (pfd) at the radio telescope exceeds the levels defined in Recommendation ITU-R RA.769.

The purpose of the present study is to determine the maximum pfd level required from non-GSO MSS systems emissions to comply with the criteria of Recommendations ITU-R RA.1513 and 769, using the methodology of Recommendation ITU-R S.1586, which is designed to take into account the non-geostationary nature of these systems when assessing their unwanted emission levels at radio telescope sites.

We then can easily verify that this maximum pfd level is sufficient to protect EESS (passive) systems operating in the band 1400-1427 MHz.

3 MSS system characteristics

The characteristics of the MSS system are given in Document 8D/393, already introduced at the last 8D meeting in September 2002. They are summarized in table 1 thereafter.

TABLE 1
MSS system characteristics

Orbital altitude	1 000 km
Orbital inclination	50 degrees (and 83 degrees for pole couverture)
Number of planes	6 (+ one more for pole couverture)
Number of satellites per plane	4
Satellite transmitter antenna gain	(See Figure 1)

Figure 1 shows the gain pattern of the example non-GSO MSS satellite circularly-polarized feeder-link antenna used in this analysis. The gain pattern of this example MSS satellite is designed to illuminate the earth equally for all elevation angles between 5 to 90 degrees.

FIGURE 1
Non-GSO MSS satellite receive and transmit antenna gain pattern

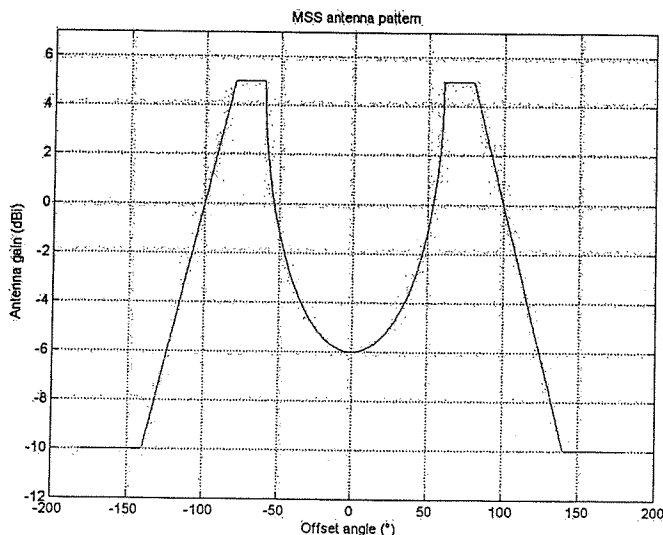

This antenna pattern allows for a constant pfd to be radiated by each MSS satellite on the Earth surface.

The antenna pattern used for offset angles greater than 60° may not be representative of the reality. However, the conclusions of this study should not change when considering a real antenna gain.

4 RAS station characteristics and protection criteria

The Effeslberg site was chosen for this analysis.

The antenna pattern and peak gain at boresight are given in recommendation ITU-R RA.1631.

TABLE 2

RAS frequency bands and detrimental interference threshold levels¹

Frequency band (MHz)	Interference level (dBW/m ²)	Reference bandwidth (MHz)	Type of observation
1330-1400	-196	0.02	Spectral line
1400-1427	-180	27	Continuum
1400-1427	-196	0.02	Spectral line

A detrimental threshold level corresponds to a protection criterion in terms of epfd of :

$$\text{epfd}_{\text{lim}} = \text{Pr}_{\text{lim}} - G_{\text{max}} - 10\log(\lambda^2/4\pi)$$

TABLE 3

RAS detrimental interference epfd threshold levels

Frequency band (MHz)	epfd interference level (dBW/m ²)	Reference bandwidth (MHz)
1330-1400	-259	0.02
1400-1427	-243	27
1400-1427	-259	0.02

¹ There is no protection criterion defined in Recommendation ITU-R RA.769 for the band 1330-1400 MHz (see No. 5.149). The protection criterion listed above for this band was derived from the one used in the band 1400-1427 MHz in case of spectral line observations.

5 EESS characteristics and protection criterion

Documents 8D/393 and 7C/79 from study period 2000-2003 give the characteristics of two EESS systems operating in the band 1420-1427 MHz. They are summarized in table 4 and 5 thereafter :

TABLE 5

SMOS system parameters

Orbital altitude	760 km
Orbital inclination	98.09° (sun-synchronous)
Maximum antenna gain	17 dBi
Bore-sight angle	34°
EES antenna pattern	See Figure 2 below

TABLE 6

HYDROS system parameters

Orbital altitude	675 km
Orbital inclination	98.09 degrees (sun-synchronous)
Antenna pointing angle and scanning	40 degrees off-Nadir with conical scan scanning
Maximum antenna gain	35 dBi
EES antenna pattern	See Figure 2 below

FIGURE 2

EESS satellites antenna pattern

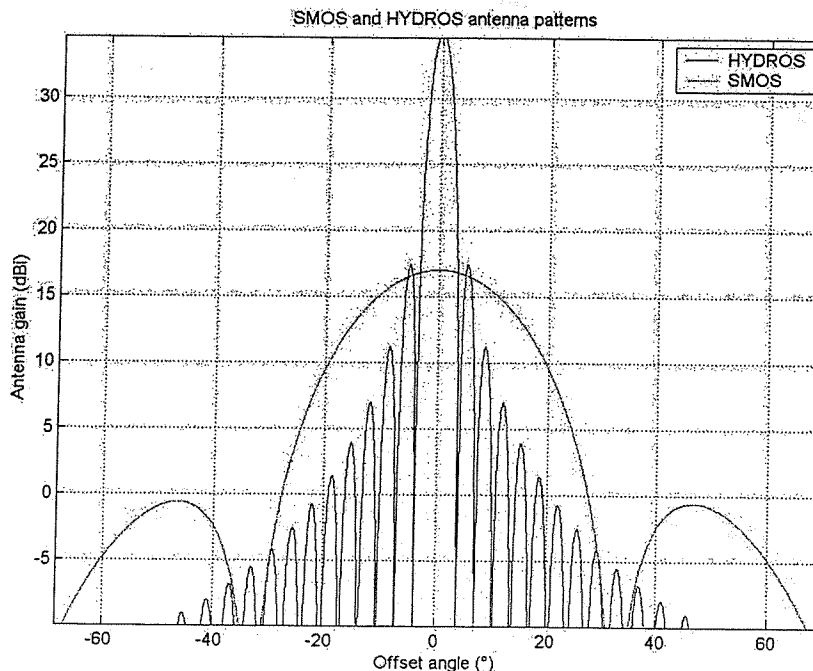

These antenna patterns represent a worst case. Moreover, for SMOS, the antenna is an interferometer. In this case some side lobe cancellation techniques may be use in order to suppress the signal received in the side-lobes of the antenna. We will see later that taking into account real antenna patterns would lead to the same conclusions.

The protection criterion for measures is given in recommendation SA.1029 and is -174 dBW not to be exceeded more than 0.1% of the time in the whole band 1400-1427 MHz. We assume the same level and 0.001% of the time for calibration periods, where the EESS sensor is looking towards deep space.

6 Determination of the required maximum pfd per satellite level for the protection of the radioastronomy service

6.1 Procedure

The following approach is used (see Recommendation ITU-R S.1586):

Step 1: Selection of a pfd value per satellite.

Step 2: Selection of a radio astronomy station.

Step 3: Division of the sky into 2334 cells of about 9 square degrees solid angle each (see Table 1 Annex 3 of Rec. ITU-R S.1586).

Step 4: For each cell, point the radio telescope towards a randomly chosen direction within the cell, and start the satellite transmissions at a randomly chosen point in time. The epfd is then evaluated for each time sample over a 2 000 s integration time, with a time step of 1 second. The average epfd corresponding to this trial is then calculated.

Step 5: If the epfd level averaged over the 2000 s integration interval of the trial exceeds the interference threshold level, that particular 2000 seconds observation is considered to be affected.

Step 6: Repeat steps 4 and 5 to get a representative number of trials (30 trials were found to be statistically sufficient).

Step 7: Determine the percentage of affected integration periods of 2 000 s over the whole sky.

Step 8: Change the pfd level from the non-GSO HEO BSS system until this percentage is below 2%.

6.2 Results

The simulation leads to the required pfd limits per MSS satellite given in table 4.

TABLE 4

Maximum Pfd levels per MSS satellite to protect radioastronomy

Band and Type of observation	Pfd limit per satellite (dBW/m ²)	Reference bandwidth (MHz)
1330-1400 MHz (spectral line)	-201	0.02
1400-1427 MHz (continuum)	-185	27
1400-1427 MHz (spectral line)	-201	0.02

The total amount of data loss is 2.07 when considering an elevation angle of 0° and 1.65 when considering an elevation angle of 3°.

Figure 1 gives for the radio astronomy site of Effelsberg, for each cell, over the whole sky, the percentage of observations where the epfd criterion has been exceeded. The total number of trials per cell is 100, the vertical scale represents the number of trials for which the epfd criterion has been exceeded.

FIGURE 3
Simulation results over Effelsberg

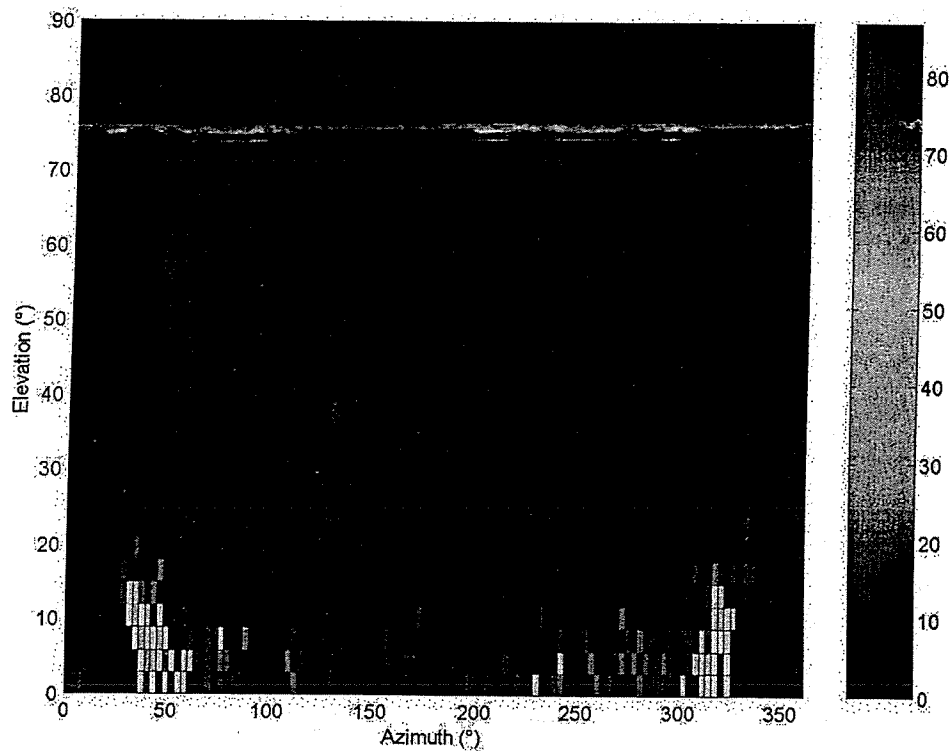

7 Assessment of interference generated by MSS in EESS (passive) sensors

We now consider that a MSS satellite radiates a constant pfd on the ground of -185 dBW/m^2 in the whole band 1400-1427 MHz. The emission power of each satellite and, therefore, the EIRP radiated in each direction can be deduced from this pfd level.

A simulation was then conducted in order to assess the level of interference received by HYDROS and SMOS sensors during measurement and calibration periods. We assume that during measurement periods the sensor is looking at the ground and scanning (when a scanning mode is present), while during calibration periods (which rarely occur), the sensor is pointing upwards, not scanning.

7.1 results for SMOS

FIGURE 4
SMOS - Measurement period

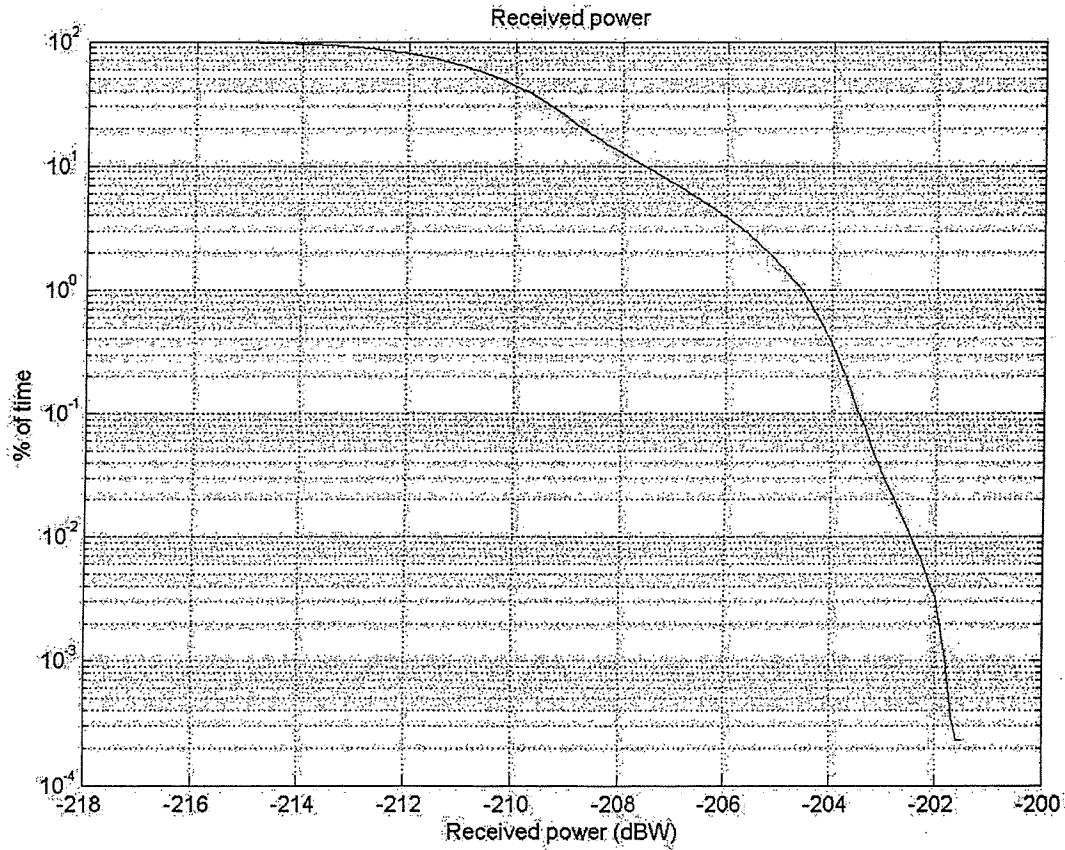
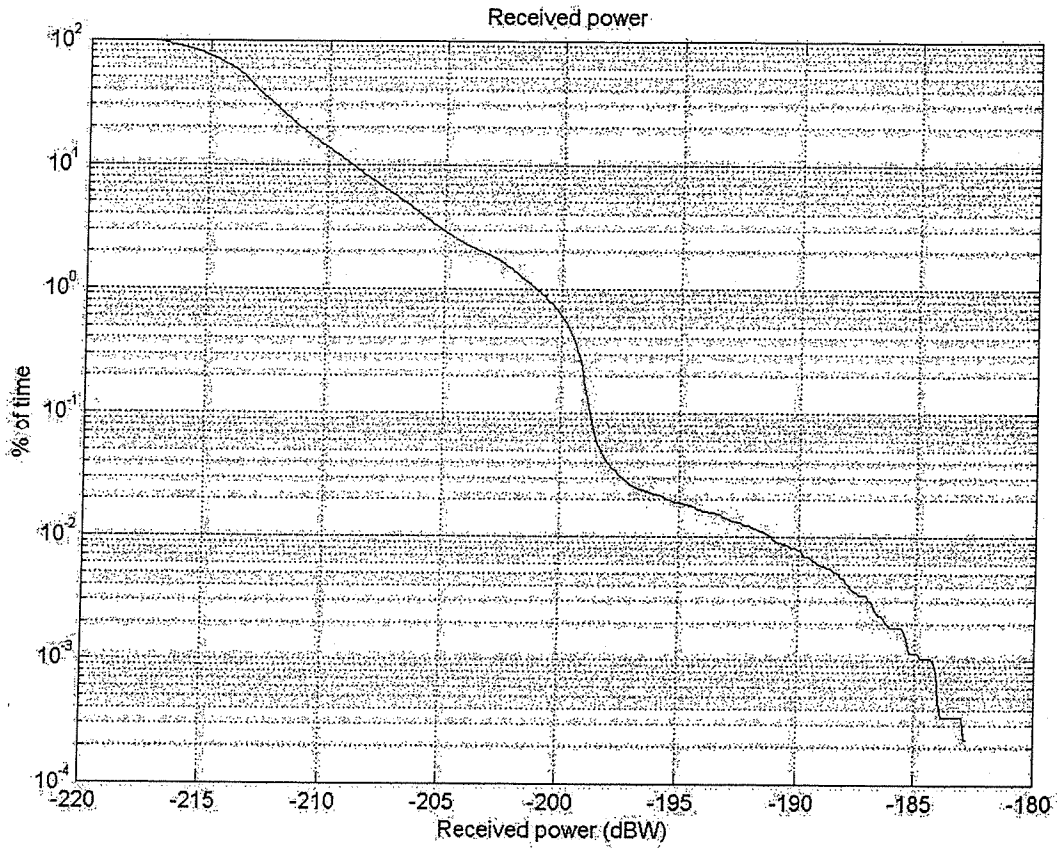

FIGURE 5
SMOS - Calibration period



One can see that there is a 29 dB margin with regard to the limit of -174 dBW for 0.1% of the time during measures and 10 dB margin with regard to the limit of -174 dBW for 0.001% of the time during calibration.

7.2 HYDROS

FIGURE 6
HYDROS - Measurement period

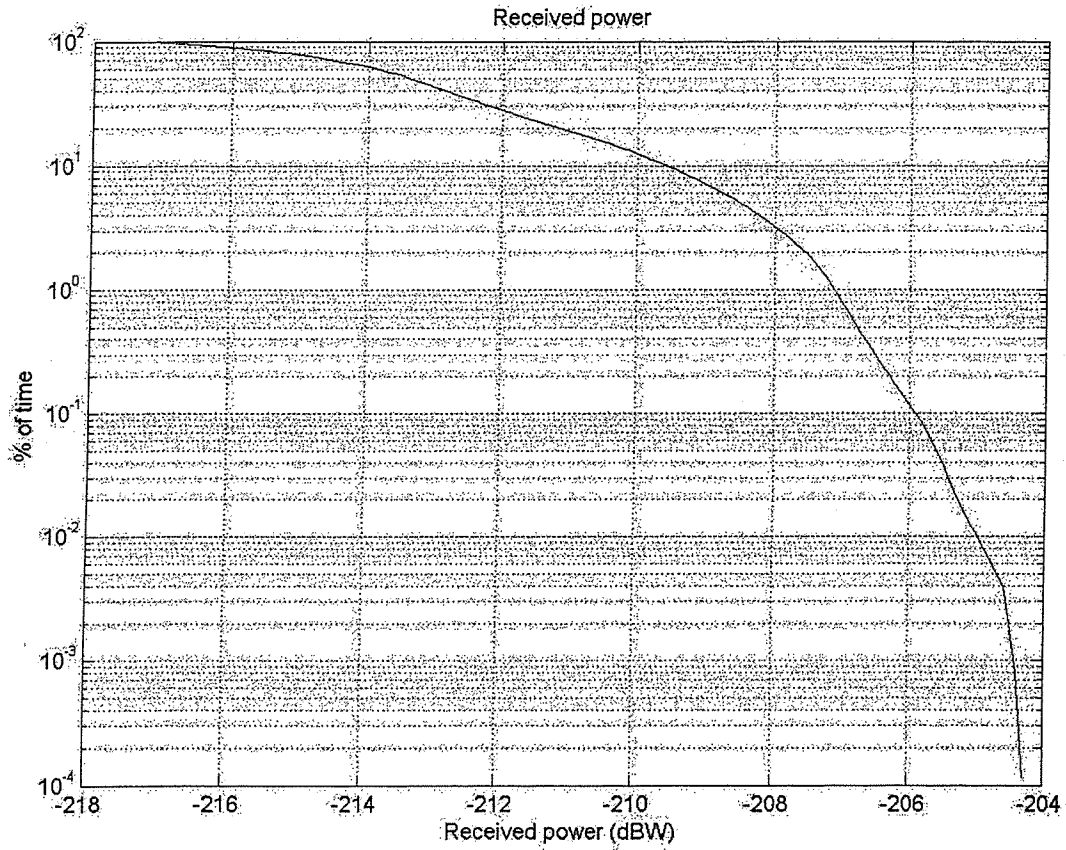
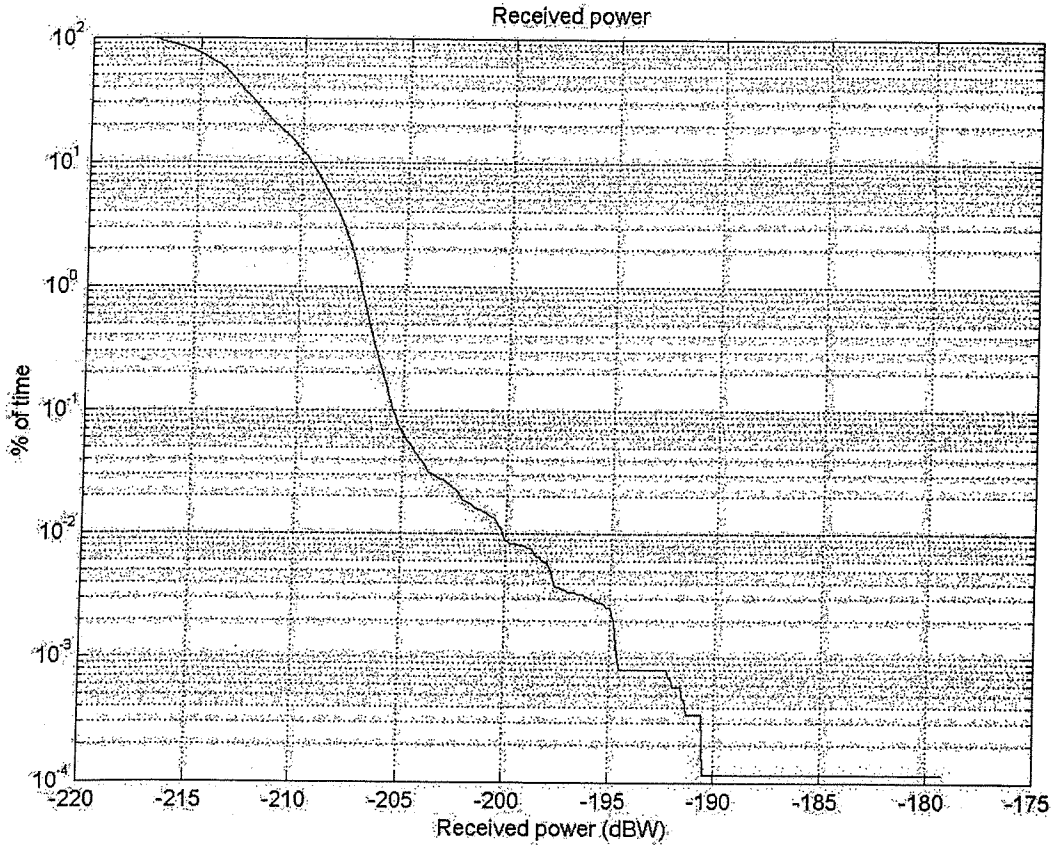

FIGURE 7
HYDROS - Calibration period



The margin is of 32 dB with regard to the limit of -174 dBW for 0.1% of the time for measurement periods and 21 dB with regard to the limit of -174 dBW for 0.001% of the time for calibration periods.

We therefore can consider that the pfd level required for the protection of the radioastronomy service is sufficient to protect the EESS.

8 Conclusions

We have shown in this paper that a pfd limit of -185 dBW/m² per MSS satellite in the whole band 1400-1427 MHz and -201 dBW/m² per MSS satellite in any 20 kHz bandwidth of the band 1400-1427 MHz is sufficient for the protection of the radioastronomy service, and that this pfd limit is also sufficient to protect the Earth Exploration Service from harmful interference.



Received: 2 October 2003

France

PROTECTION OF THE EARTH EXPLORATION (PASSIVE) SPACE SERVICE OPERATING IN THE BAND 1 400-1 420 MHz FROM UNWANTED EMISSIONS OF MSS FEEDER LINKS OPERATING IN THE BAND 1 390-1 392 MHz

1 Introduction

WRC-03 made a secondary allocation to the FSS for MSS feeder links through No 5.BB05 as follows:

“5.BB05 Additional allocation: the band 1 390-1 392 MHz is also allocated to the fixed-satellite service (Earth-to-space) on a secondary basis and the band 1 430-1 432 MHz is also allocated to the fixed-satellite service (space-to-Earth) on a secondary basis. These allocations are limited to use for feeder links for non-geostationary-satellite networks in the mobile-satellite service with service links below 1 GHz, and Resolution 745 [COM5/14] (WRC-03) applies. (WRC-03)”

Resolution 745 [COM5/14] (WRC-03) states that this new allocation can not be used until all studies pertaining to sharing between FSS and other services in the allocated bands or the passive adjacent band are completed. A new Agenda item (1.17) was approved for the agenda of the next conference.

The purpose of this document is to analyse the sharing conditions between the FSS (uplink) and the EESS, to determine the attenuation that would be necessary in order to protect the EESS (passive) from harmful interference.

2 Methodology

A simulation was developed to evaluate the level of interference generated in passive sensors like SMOS and HYDROS by several MSS feeder links Earth Stations deserving one single MSS constellation. We assume a given value for the power radiated by each MSS Earth Station in the passive band and derive the power received by the EESS sensor with the associated percentage of time. The comparison with the protection criterion gives the attenuation required and the allowed emission power value in the whole passive band.

For calculation length purposes, the simulation was limited to a time period of 5 days, and the time step limited to 1 second. The influence of a lower time step is perceivable only for low percentages of time (<0.01%) on the cumulative distribution function.

3 MSS system characteristics

The characteristics of the MSS system are given in Doc. 8D/393, already introduced at the last8D meeting in September 2002. They are summarized in table 1 thereafter.

TABLE 1
MSS system characteristics

Orbital altitude	1 000 km
Orbital inclination	50 degrees (and 83 degrees for pole covertures)
Number of planes	6 (+ one more for pole couverture)
Number of satellites per plane	4
Satellite coverage area	Typically, approx. 4 000 km diameter
Number of feeder-link (earth) stations per satellite coverage area	6 max
Earth station transmitter power (assumed in the passive band)	10 watts
Earth station transmitter line loss	1 dB
Earth station transmitter antenna gain	30 dBi
Earth station bandwidth	100 kHz
Earth station antenna pattern	RR Appendix 8 (Annex III)

We consider 15 MSS Earth Stations randomly located on the Earth as shown in figure 1. Whenever two MSS satellites are in visibility of one MSS Earth Station (elevation angle $> 5^\circ$), we consider that this station is following the nearest satellite. These hypothesis will allow a direct comparison with the US contribution (Doc. 7C/7)

FIGURE 1

MSS Earth Stations location

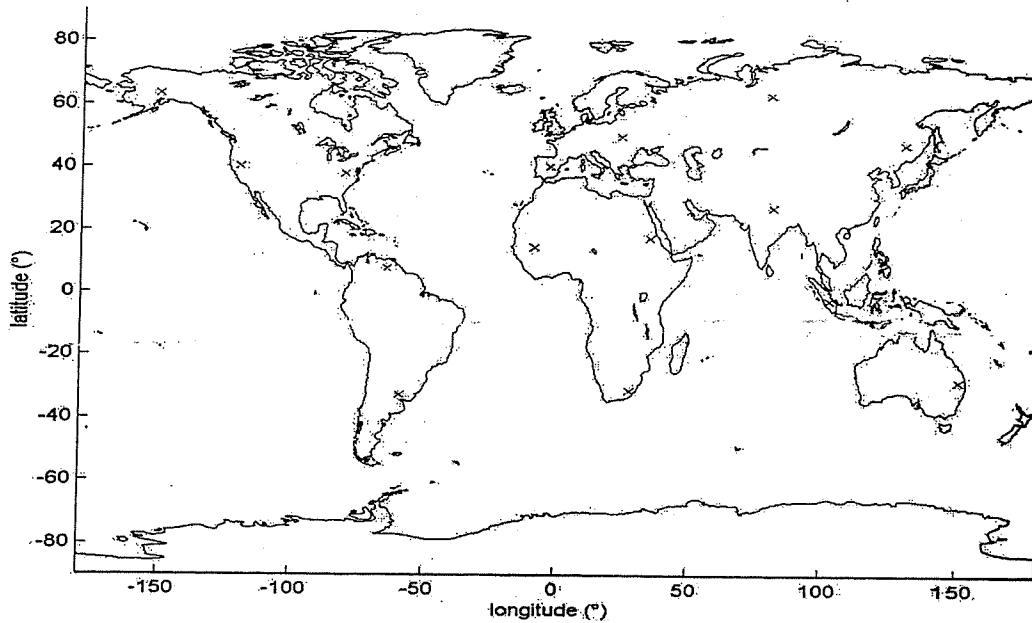

4 EESS characteristics and protection criterion

Documents 8D/393 and 7C/79 from Study Period 2000-2003 give the characteristics of two EESS systems operating in the band 1 420-1 427 MHz. They are summarized in Tables 4 and 5 thereafter:

TABLE 2
SMOS system parameters

Orbital altitude	760 km
Orbital inclination	98.09° (sun-synchronous)
Maximum antenna gain	17 or 9 dBi
Bore-sight angle	34°
EES antenna pattern	See Figure 2 below

TABLE 3
HYDROS system parameters

Orbital altitude	675 km
Orbital inclination	98.09 degrees (sun-synchronous)
Antenna pointing angle and scanning	40 degrees off-Nadir with conical scan scanning
Maximum antenna gain	35 dBi
EES antenna pattern	See Figure 2 below

FIGURE 2
EES satellites antenna pattern

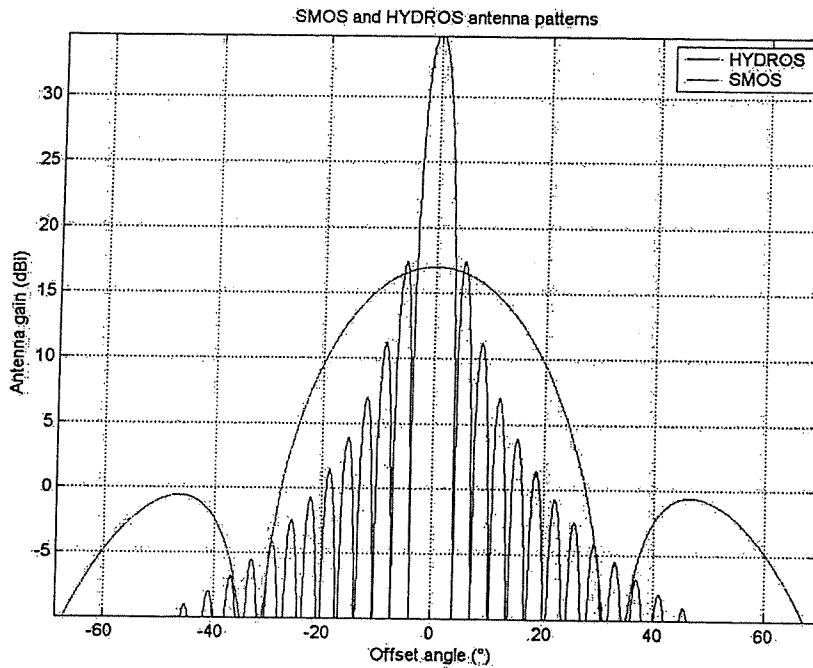

These antenna patterns represent a worst case. An alternative antenna pattern was used for HYDROS, based on data provided in previous papers introduced within WP 7C and 8D. This pattern is shown on Figure 3.

FIGURE 3
HYDROS more realistic antenna pattern

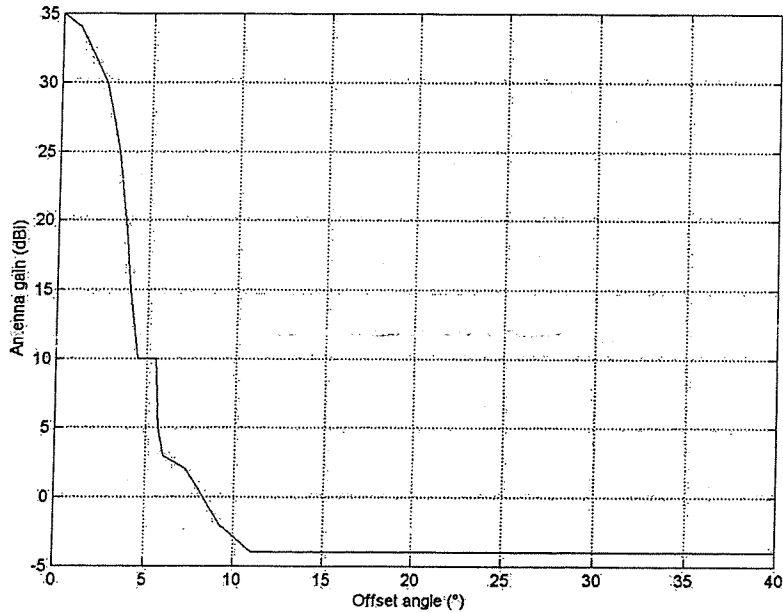

If data is available on the antenna pattern of the HYDROS sensor, there is a need to obtain more detailed information on the SMOS antenna pattern, including the maximum antenna gain. In order to see the influence of this antenna gain on the results, the simulation was conducted considering a 17 dBi and 9 dBi maximum antenna gains.

The protection criterion for measures is given in Recommendation ITU-R SA.1029 and is -174 dBW not to be exceeded more than 0.1% of the time in the whole band 1400-1 427 MHz.

5 Simulation results

FIGURE 4
Simulation results for SMOS – Antenna gain 17 dBi

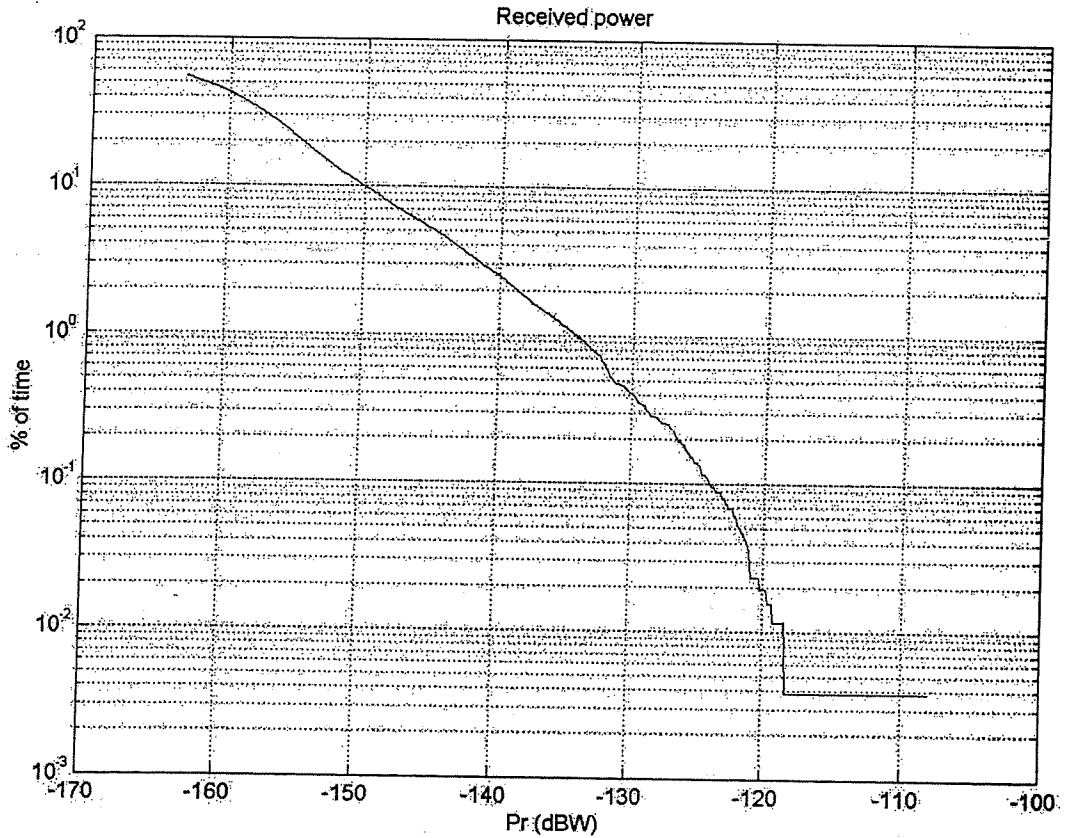

The analysis of the cdf shows that a received power value of -124 dBW is obtained for 0.1% of the time, which leads to an MSS Earth station emission power of $-174 - (-124) + 10 = -40$ dBW allowed in the whole passive band, assuming that all MSS Earth stations radiate the same out-of-band level.

FIGURE 5
Simulation results for SMOS – Antenna gain 9 dBi

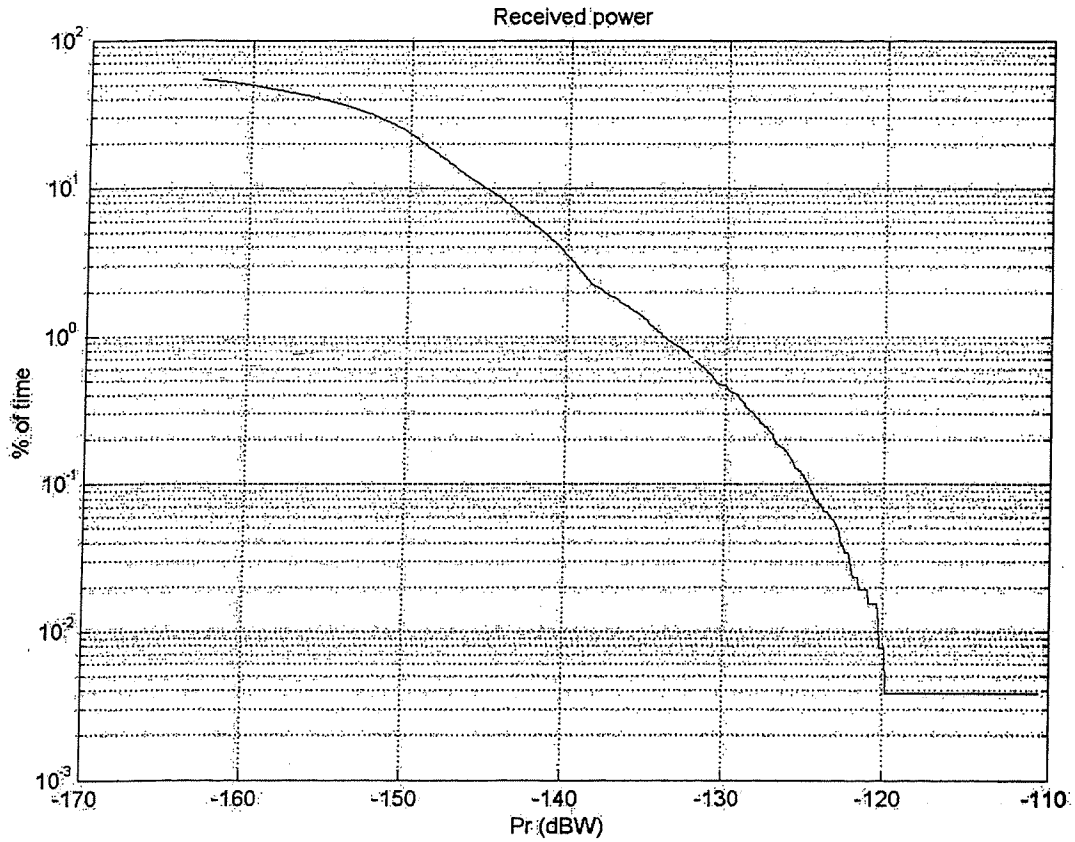

The analysis of the cdf shows that a received power value of -125 dBW is obtained for 0.1% of the time, which leads to an MSS Earth station emission power of $-174 - (-125) + 10 = -39$ dBW allowed in the whole passive band, assuming that all MSS Earth stations radiate the same out-of-band level.

FIGURE 6
Simulation results for HYDROS / Bessel antenna pattern

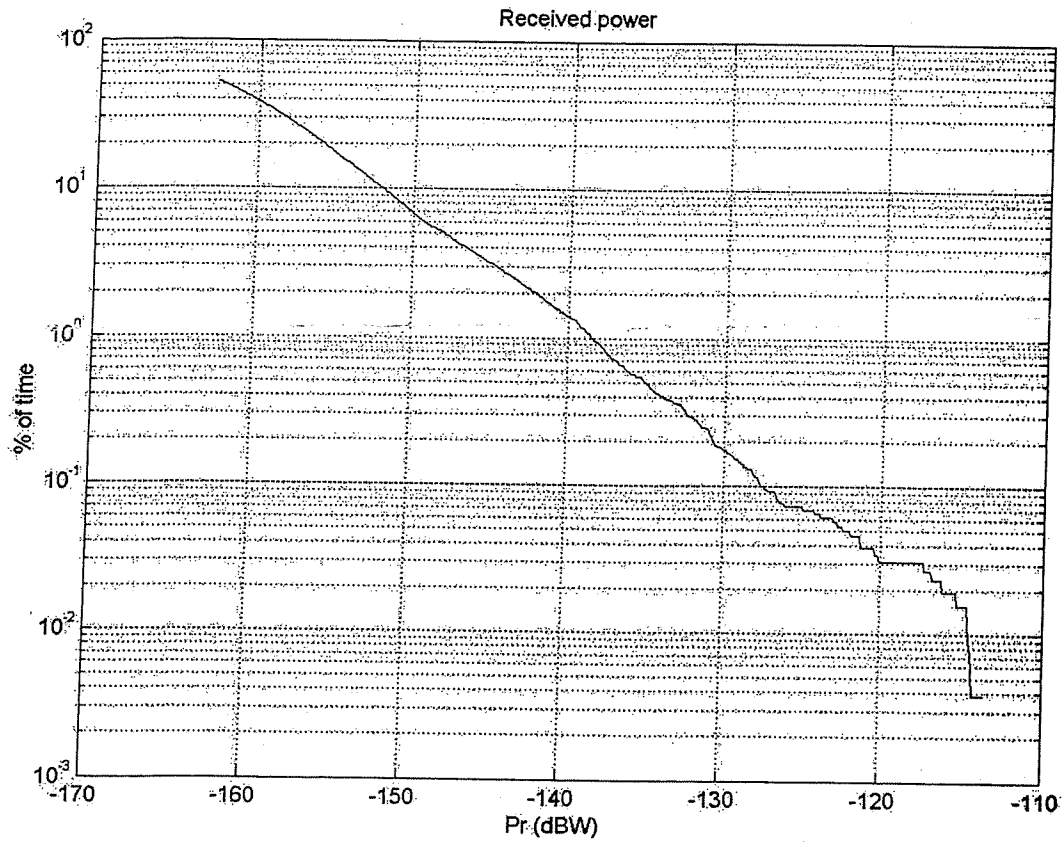

The analysis of the cdf shows that a received power value of -127 dBW is obtained for 0.1% of the time, which leads to an MSS Earth station emission power of $-174 - (-127) + 10 = -37$ dBW allowed in the whole passive band, assuming that all MSS Earth stations radiate the same out-of-band level.

FIGURE 7

Simulation results for HYDROS / HYDROS antenna pattern

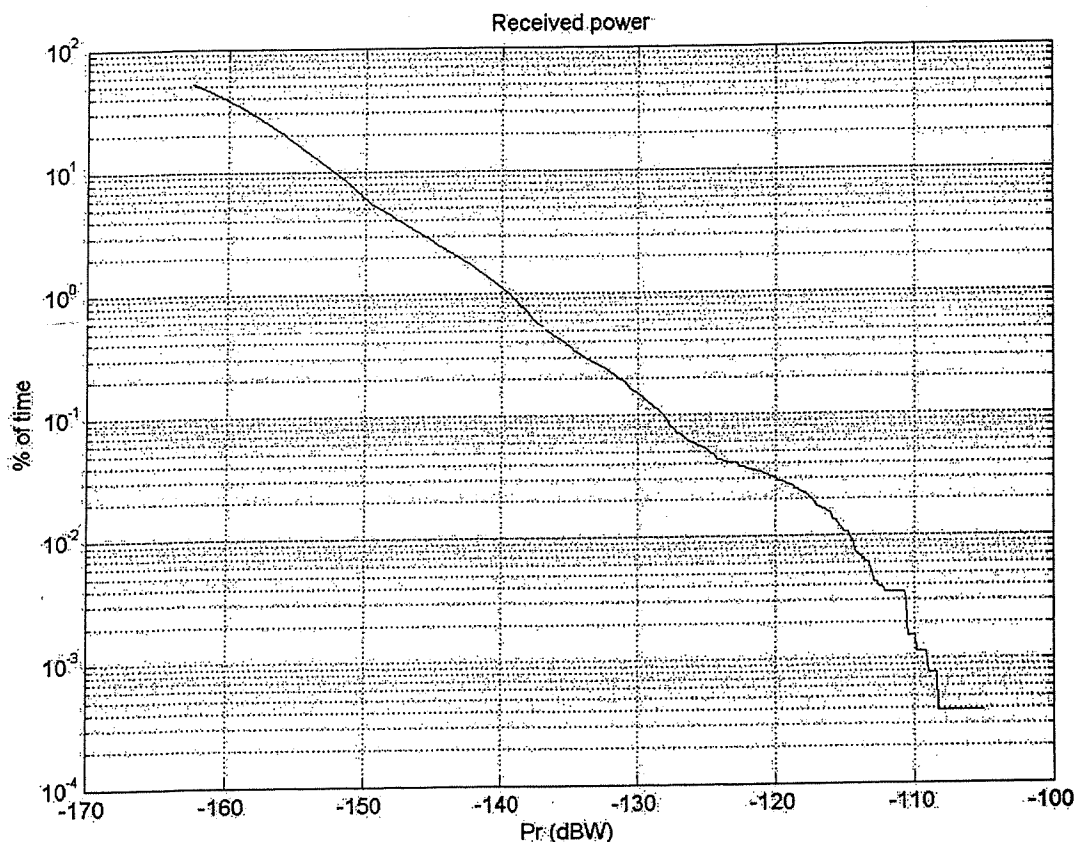

The analysis of the cdf shows that a received power value of -128 dBW is obtained for 0.1% of the time, which leads to an MSS Earth station emission power of $-174 - (-128) + 10 = -36$ dBW allowed in the whole passive band, assuming that all MSS Earth stations radiate the same out-of-band level. These results are consistent with the results obtained in the US contribution (-129 dBW). The slope of the cdf curve is also the same, although this simulation is not based on a commercial software.

6 Preliminary Conclusions

A simulation tool was developed in order to assess the interference level produced by MSS feeder link Earth Stations in EESS (passive) sensors. The results obtained are similar to the results contained in the US Doc. 7C/8.

These preliminary simulations show that a power level in the order of -40 dBW radiated in the whole passive band by each MSS Earth Station, assuming an antenna pattern consistent with Appendix 8 Annex III, a maximum antenna gain of 30 dBi and a number of MSS Earth Stations of 15 worldwide would allow the MSS to meet the EESS (passive) protection criterion.

This power level corresponds in fact to a level of -55 dBW in a reference bandwidth of 1 MHz, which, for an emission power of 10 W, leads to a spurious level of 65 dBc, which is higher than the level of 53 dBc specified in appendix 3 of the Radio Regulations. There is therefore a need for a

particular regulatory provision to protect the EESS (passive). This regulatory provision needs to take into account an out-of-band emission limit, but also some limitation on the antenna pattern of the MSS Earth Station.

The aim of this study was mainly to determine the order of attenuation required to protect the EESS (passive). It is based on several hypotheses which need to be confirmed or corrected:

- the antenna pattern for the EESS sensors needs to be refined to be consistent with the available information for planned sensors, particularly for SMOS,
- the number of MSS systems and associated Earth stations has an influence on the results and needs to be discussed,
- the polarization loss is only valid for the main beam and maybe the first side lobes. The polarization in the far side lobes is not known and it cannot be considered that there is any polarization loss in this case,
- No EESS feeder loss was considered.

Further studies are needed to refine these results accordingly.

Radiocommunication Study Group Fact Sheet

Task Group: WP-8D	Document No: US WP-8D/07 Rev. 1
Reference: WRC03/38 Addendum 1 WRC03/38 Addendum 2	Date: October 14, 2003
Document Title: Results of tests, measurements and studies pertaining to containment of unwanted emissions in response to Resolution 745.	
Author: Ralph Crenshaw	Phone: 301 459 0100 x217 FAX: 301 459 0101 E-mail: rcrenshaw@finalanalysis.com
Purpose/Objective: The objective of this contribution is to submit to the ITU working parties technical information that was submitted to WRC-03 within document WRC03/38 Addendum 1 and WRC03/38 Addendum 2 in response to the resolves of Resolution 745 (WRC-03).	
Abstract: This study demonstrates the practicability of implementing a spaceborne transmitter and earth station transmitter that can attenuate unwanted emissions in excess of what is required to protect the passive services in the band 1 400-1 427 MHz from non-GSO narrow-band feeder links operating in the nearby bands 1 390-1 392 MHz (Earth-to-space) and 1 430-1 432 MHz (space-to-Earth).	

USWP8D/7 Rev 1
October 14, 2003
Original: English

United States of America

Results of tests, measurements and studies pertaining to containment of unwanted emissions in response to Resolution 745.

This document submits to Working Party 8D the Results of test, measurements and studies pertaining to the containment of unwanted emission from non-GSO FSS feeder links, with mobile services below 1 GHz, operating in the bands 1390-1392 MHz, Earth-to-space, and 1430-1432 MHz, space-to-Earth. These results were submitted to WRC-03 within WRC03/38 Addendum 1 and WRC03/38 Addendum 2.

Annex 1 Results of tests, measurements and studies conducted in response to Resolution 127 and relevant to WRC-2000 agenda item 1.16 (Source Document WRC03/38 Addendum 1)

This Annex provides the results of tests, measurements and studies identified in *invites ITUR* 1, 2 and 3 of ITU-R Resolution 127 (Rev. WRC-2000). In Resolution 127, the ITU-R, with the participation of administrations, is invited:

- 1) and 2) to carry out additional tests and demonstrations to validate studies on operational and technical means to facilitate sharing in portions of the bands 1 390-1 393 MHz and 1 429-1 432 MHz between existing and currently planned services and feeder links (Earth-to-space) and (space-to-Earth) for non-GSO MSS systems with service links operating below 1 GHz,
- 3) to carry out additional studies, including the measurement of emissions from equipment that would be employed in operational systems to protect passive services in the band 1 400-1 427 MHz from unwanted emissions from feeder links near 1.4 GHz for non-GSO MSS systems with service links operating below 1 GHz.

A laboratory in the United States recently completed tests, measurements and studies showing that for a non-GSO MSS transmitter operating in the band 1 430-1 432 MHz (space-to-Earth) the practicable levels of attenuation of out-of-band emissions exceed the value of 73 dB that studies have shown would provide acceptable interference power into EESS (passive) systems operating in the frequency band 1 400-1 427 MHz. Studies performed with the tests have shown that additional attenuation of 10 to 30 dB is achievable through the use of post-transmitter filters on the satellites.

On the basis of those tests and studies of transmitters in the band 1 430-1 432 MHz, it is concluded that for non-GSO MSS feeder links in the band 1 390-1 392 MHz with earth station transmitters similar to the transmitters tested (similar in power levels, up to 50 W, and at nearly the same frequency), the achievable out-of-band emission levels and additional post-transmitter filtering of 30 dB can practicably result in attenuation levels of unwanted emissions greater than the

approximately 119 dB required to produce acceptable interference levels into EESS (passive) systems operating in the frequency band 1 400-1 427 MHz. This Annex summarizes the results of these recently completed tests, measurements and studies that were requested by Resolution 127 to be completed prior to WRC-03.

Annex 2 Tests, measurements and studies conducted in response to resolution 127 and relevant to agenda item 1.16 (Source Document WRC03/38 Addendum 2)

This annex presents a detail of laboratory test and measurement results and studies conducted in response to Resolution ITU-R 127 and summarized in Annex 1. The results of this study indicates the practicability of implementing a spaceborne transmitter that can attenuate unwanted emissions in excess of what is required to protect the passive services in the band 1 400-1 427 MHz from non-GSO narrow-band feeder links operating in the nearby bands 1 390-1 392 MHz (Earth-to-space) and 1 430-1 432 MHz (space-to-Earth).

Annex 3 Description of Spaceborne Modulator and Upconverter Design

This annex provides additional information describing the spaceborne and ground station modulator and upconverter and power amplifier design that along with the amplifier comprised was the unit under test in Annex 2 in test configuration 2.

ANNEX 1

Results of tests, measurements and studies requested by Resolution 127 prior to WRC-03

1 Introduction

Resolution 127 (Rev.WRC-2000) "Studies relating to consideration of allocations in bands around 1.4 GHz for feeder links of the non-geostationary-satellite systems in the mobile-satellite service with service links operating below 1 GHz" invited ITU-R as a matter of urgency to carry out additional studies, including the measurement of emissions from equipment that would be employed in operational systems to protect passive services in the band 1400-1 427 MHz from unwanted emissions from feeder links near 1.4 GHz for non-GSO MSS systems with service links operating below 1 GHz.

Resolution 127 considered that theoretical analyses have indicated that sufficient reduction of out-of-band and spurious emissions could be achieved to protect the sensitive science services in the band 1 400-1 427 MHz. It also considered that it is necessary to conduct additional tests and measurements of feeder-link transmissions from systems having the characteristics, performance and reliability of equipment that would be used in operational systems and that such tests would be completed prior to WRC-03.

A laboratory in the United States with extensive experience with spaceborne communication applications was commissioned to perform the following tasks:

- determine that a transmitter with the required dynamic range can be realized in the laboratory;
- determine that the technology is available to implement a spaceborne transmitter with the required attenuation of unwanted emissions;
- address reliability issues relating to ensuring that the required level of performance is achieved during the lifetime of the satellite.

This report presents a summary of laboratory test and measurement results and studies conducted in response to ITU-R Resolution 127. (The complete laboratory report is Reference 1.) These results indicate the practicability of implementing a spaceborne transmitter that can attenuate unwanted emissions in excess of what is required to protect the passive services in the band 1 400-1427 MHz from non-GSO narrow-band feeder links operating in the nearby bands 1 390-1 392 MHz (Earth-to-space) and 1 430-1 432 MHz (space-to-Earth).

2 Summary of test results

2.1 Determination that a transmitter with the required dynamic range can be realized in the laboratory (Reference 1, pages 2-24)

Output spectral plots taken on various combinations of evaluation hardware show that it is feasible to implement a GMSK transmitter which will meet the ITU requirements regarding unwanted emissions (i.e. when transmitting in the band 1 430-1432 MHz, no emissions allowed above 86 dBsd in the adjacent 1 400-1 427 MHz band).

TABLE 1
Hardware combinations tested

Config.	GMSK data source	RF upconverter	Power amplifier
1	signal generator	N/A	50-W TWTA
2	breadboard	Breadboard	50-W TWTA and 0.1-W SSPA

No extraordinary methods beyond standard good RF practice were required to achieve these measured results. A high performance spectrum analyser was used to make the spectrum measurements. The signal-free noise floor of the analyser was measured at least 6 dB below the measured minimum signal, verifying adequate dynamic range for the measurements.

Post-TWT filtering was not required to attain the 86 dBsd requirement. The use of such filtering would increase margin towards the ITU requirement. Spectral degradation of the GMSK signal floor post-SSPA or post-TWTA was within 1 dB of similar measurements taken before the power amplifiers.

2.1.1 Configuration 1 (Reference 1, pages 2-10)

A commercial signal generator was configured to produce a shaped, phase modulated carrier at 1 430 MHz, with a data bandwidth of approximately 100 kHz and a carrier frequency of 1 430 MHz. Since the modulation was not precisely constant amplitude, spectral regrowth was noticeable at the output of the TWTA. However, the regrowth was not significant at 3 MHz from carrier frequency. Spectral attenuation results for Configuration 1 are summarized in Table 2.

TABLE 2
Spectral attenuation vs. TWTA input back-off (signal generator)

Input back-off from SAT (dB)	Relative output power (dBm)	Density at 1 430 MHz (dBm/3 kHz)	Density at 1 427 MHz (dBm/3 kHz)	Spectral Attenuation (dBsd)
0	17.3	-9.0	-102.3	93.3
2	17.1	-9.2	-102.1	92.9
4	16.6	-9.6	-103.3	93.7
10	12.9	-9.4	-101.6	92.2

2.1.2 Configuration 2 (Reference 1, pages 11-24)

A modulator breadboard (S/N 002) was connected first to the 50-W TWTA, and then to a medium-power (100 mW) SSPA. The breadboard generated a GMSK modulated L-band carrier (at 1 430 MHz). Discrete spectral lines were observed at 2 MHz and 3.6 MHz away from 1 430 MHz and were approximately 69 dBsd below the peak of the modulated spectra. Measured spectral attenuation at the output of the breadboard was approximately 90 dBsd at 1 427 MHz (relative to spectral density at 1 430 MHz). Little degradation was observed in the spectral attenuation when passed through the TWTA and there is no noticeable spectral regrowth, indicating that the breadboard modulation is constant amplitude, as would be expected with properly implemented GMSK. Similarly, little degradation was observed in spectral attenuation when passed through a medium power (100 mW) SSPA. The amplifier was operated at 1 dB output compression, and spectral attenuation was 92.2 dBsd at 1 427 MHz, relative to spectral density at 1 430 MHz.

Spectral degradation through a properly operating power amplifier is minimal and does not appear to be a limiting factor in meeting requirements at 1 427 MHz.

Spectral attenuation results for configuration 2 are summarized in Table 3.

TABLE 3
Spectral attenuation vs. TWTA input back-off (breadboard modulator)

Input back-off from SAT (dB)	Relative output power (dBm)	Density at 1 430 MHz (dBm/3 kHz)	Density at 1 427 MHz (dBm/3 kHz)	Spectral attenuation (dBsd)
0	17.3	-7.9	-99.5	91.6
2	17.0	-7.9	-99.2	91.3
4	16.5	-9.1	-99.5	90.4
10	12.4	-7.8	-97.0	89.2

2.1.3 Post-amplifier filter

No tests were performed with post-amplifier, high power filters, as all tested configurations met the 86 dBsd spectral interference requirement without filtering. The laboratory has direct experience in specifying high-power, flight bandpass filters at a similar L-band frequency for another satellite program. Based on interpolation of existing filter specifications and the same vendor's response to specific requirements, 10 to 30 dB of additional attenuation can reasonably be expected with the use of a post-power amplifier filter.

2.2 Availability of technology to implement a spaceborne transmitter

A summary of path-to-flight issues (Table 4) addresses potential beginning-of-life (BOL) performance issues as the modulator-transmitter design evolves into space-qualified hardware from the breadboards measured on this task.

TABLE 4
Summary of path-to-flight issues

Building block	Comments	Projected performance delta
L.O. carrier	Breadboards use either laboratory test equipment synthesizer or RFIC source; flight equivalent likely would use crystal oscillator with multiplier chain	No expected degradation
Digital modulation	Breadboard uses 16-bit dual DACs; breadboard uses 10-bit DACs, which are available as flight qualified	No expected degradation
RF upconverter/modulator	Breadboard uses RFIC or RF mixers and hybrids; flight equivalent would use similar technology	No expected degradation
Output power amplifier	Breadboard uses 50-W TWTA; flight equivalent would use smaller TWTA or SSPA	No expected degradation
Post amplifier filter	None used in breadboard measurements; high power flight filters from other satellite programs show availability if necessary	Additional 30 dB of positive margin towards ITU spectral density interference specification

A small number of building block components can be assumed to have the potential to contribute to degradation of spectral density attenuation of a GMSK modulator-transmitter as a flight hardware configuration evolves from the breadboard designs tested under this task.

From discussions with a developer of the satellite regarding likely limitations on the mechanical design of the flight modulator-transmitter, it was understood that the anticipated vehicle which will be used to launch the satellite has sufficient capacity to minimize the need to impose stringent size (volume), weight and power constraints. The result of this excess launch capacity is a positive simplification of the flight hardware design, as a wider selection of components becomes available to choose from.

2.2.1 L.O. carrier

Tested hardware configuration No. 1 used Agilent test equipment synthesizers to generate the L-band carriers. Agilent synthesizers typically have excellent carrier phase noise performance, above what would be expected in a flight L.O. However the breadboards (configuration No.2) use a commercial quality RFIC synthesizer, and the measured GMSK spectral performance did not appear to be limited by the performance of that L.O. source (synchronized against a laboratory 10 MHz standard), as spectral attenuation performance was very similar in all configurations measured at the laboratory.

Specified and measured performance of space quality oscillators indicate that at a distance of 3 MHz from the centre frequency, the phase noise of a multiplied crystal oscillator should typically be better than -140 dBc, which would provide greater than 40 dB of margin over what is needed to avoid contributing to degradation of the GMSK spectrum.

2.2.2 Digital modulation

The projected 100 kbps data rate is well within the range of available space-qualified digital ICs in bipolar or CMOS technologies, thus the translation of the digital designs used in the GMSK breadboards to flight qualified implementations is straightforward, with the exception of the 16-bit dual D-to-A converters used in the output stage of the testbed digital modulator.

The 12-bit high-speed DACs used in the breadboard modulator are available as space-qualified devices for use in the flight modulator design, thus no degradation of the performance of the digital subsection is expected as compared to the tested breadboard.

2.2.3 RF upconverter

The signal generator and breadboard both utilize RFIC modulators. In the case of the RFIC modulator, a path to flight is expected to be available through the specific vendor's space qualified fabrication process. In the worst case, this component may require individual qualification if no equivalent heritage part built in the same fab process is located before the design is fixed.

2.2.4 Output power amplifier

The 50-W TWTA used in the testing of all modulator breadboards has extensive flight heritage. Satellite transmitter requirements are understood to be significantly lower (1-W space, 10-W ground) than the tested TWTA, however the measured performance of the spectral interference pre- and post-TWTA shows that there is insignificant performance degradation of the GMSK waveform in this major component, even at the higher (50-W) power level.

1-W or 10-W L-band solid-state amplifiers were not readily available to support these tests, however no significant difference in degradation is expected if SSPAs were selected for use over TWTAs. The 100 mW SSPA that was tested with the breadboard had slightly less spectral interference degradation as compared against the performance seen with the 50-W TWTA.

2.2.5 Post-amplifier filter

No tests were performed with post-amplifier, high power filters, as all tested configurations met the 86 dBsd spectral interference requirement without filtering. The laboratory performing this task has direct experience in specifying high-power, flight bandpass filters at a similar L-band frequency for another satellite program. Based on interpolation of existing filter specifications and the same vendor's response to specific F requirements, 10 to 30 dB of additional attenuation can reasonably be expected with the use of a post-power amplifier filter.

2.3 Reliability issues related to ensuring that the required level of performance is achieved over a seven-year period when on orbit. (Reference 1, page 28)

Well-understood and documented environmental and ageing effects affect the long-term, on-orbit satellite payload performance. The breadboard test results performed thus far require extrapolation to ensure compliance with ITU requirements at the end of the seven-year mission life (EOL) due to normal ageing effects and exposure to radiation, temperature and the space environment.

The same process through which components are selected for the flight design is also critical to ensuring compliance with overall performance specifications at EOL.

2.3.1 Analogue components (including oscillator)

Long-term stability of the master crystal oscillator in space environments is well understood and generally not a problem in the satellite if specified prior to acquisition for flight. Typical frequency drift of less than 10^{-8} is reasonable to expect and well within the necessary performance to stay within ITU requirements. Phase noise degradation does not occur to the levels where it would impact spectral interference, other than in the event of catastrophic component failure.

2.3.2 Digital components (GMSK shaping)

Digital circuits have less sensitivity to ageing and temperature effects as compared with analogue circuits, and most necessary digital circuit building blocks are available in space qualified versions. The most common problem with digital circuitry in space is the effect of single event upsets (SEU) due to radiation. Where necessary, the selection of rad-hard digital devices (such as processors, memories and gate arrays) or the use of selective mechanical shielding provides the means to mitigate sensitivity to radiation. The breadboard digital modulator will be used to process a constant flow of data, and as such is much less sensitive (from a system and practical user standpoint) to the effects of SEUs.

2.3.3 RF components (upconverter)

The most common degradation seen in RF components is a loss of gain in active amplifiers as characteristics change over time and exposure to radiation. The satellite industry mitigates these effects upon the overall system through the choice of properly designed and tested components with minimal sensitivity to these changes.

2.3.4 Power components

As with the above RF components, the satellite industry has much experience in designing and producing power amplifiers for 10-15 year life in orbit, and a graceful degradation is expected in a

properly designed power amplifier. The use of redundant blocks mitigates unexpected random failures due to components or workmanship issues.

3 Summary

Spaceborne transmitters, with 90 dBsd attenuation of unwanted emissions, are practicable without the use of post transmitter filters. With the use of post transmit filters an additional 30 dB of attenuation of unwanted emissions is possible. No extraordinary methods, beyond standard good RF practice, are required to achieve these results.

ANNEX 2

FINAL REPORT

Evaluation of Containing Unwanted Emissions for a proposed non-GSO MSS Global Telecommunications System

Task 1. Prove that a transmitter with the required dynamic range can be realized in the lab.

Task 1 Results

Output spectral plots taken on various combinations of evaluation hardware show that it is feasible to implement a GMSK transmitter which will meet the ITU requirements regarding unwanted emissions (i.e. when transmitting in the band 1 430-1 432 MHz, no emissions allowed above 86 dBsd in the adjacent 1 400-1 427 MHz band).

Table 1. Hardware combinations tested

Config	GMSK Data Source	RF Upconverter	Power Amplifier
1	Agilent 8648D	N/A	Hughes 50-W TWTA
2	FACS breadboard	FACS breadboard	Hughes 50-W TWTA or WJ 0.1-W SSPA

No extraordinary methods beyond standard good RF practice were required to achieve these measured results. An Agilent PSA series spectrum analyser (Model E4440A) was used to make the measurements. Auto-coupling of the analyser settings was overridden to maximize measurement range, and details of the instrument settings used to make spectrum measurements are provided in Appendix A to Annex 2. The signal-free noise floor of the analyser was measured at least 6 dB below the measured minimum signal, verifying adequate dynamic range for the measurements.

Minor modulator filtering (pre-TWTA) in the flight hardware may be needed to attain the 86 dBsd requirement over the entire 1 420-1 427 MHz band. In the FACS modulator, two in-band spurious images were observed, however an additional 2-3 dB of bandstop filtering would be sufficient to meet ITU requirements and increase margin. Spectral degradation of the GMSK signal floor was less than 1 dB through the SSPA or TWTA.

Configuration 1

A commercial Agilent signal generator (8648D) was configured to produce a shaped, phase modulated carrier at 1 430 MHz, with a data bandwidth of approximately 100 kbps. Figs. 1.1.1a and 1.1.1b (next page) show the modulated spectrum at the carrier frequency (1 430 MHz) and residual modulation at 1 427 MHz as measured on an Agilent E4440A spectrum analyser. The spectral attenuation at the output of the generator was ~90 dBsd at 1 427 MHz [(-15.7 dBm at 1 430 MHz)-(-105.5 dBm at 1 427 MHz)]. The measured generator spectral floor of -105.5 dBm was 9.5 dB higher than the signal-free floor of the spectrum analyser at -115.0 dBm, implying a measurement error of less than 0.5 dB.

Fig. 1.1.1a. Agilent modulator at 1 430 MHz

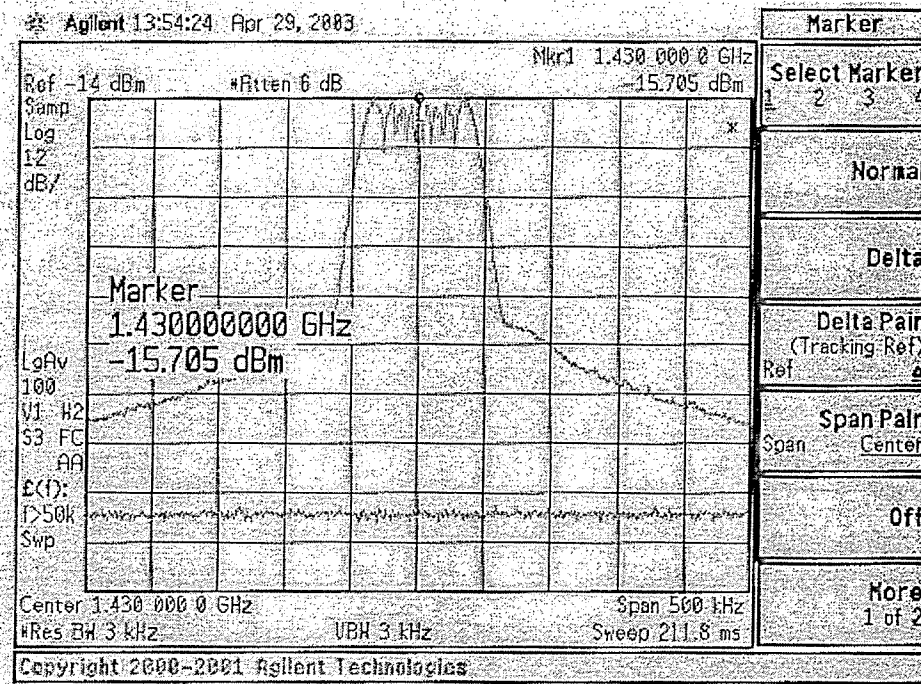

Fig. 1.1.1b. Agilent modulator at 1 427 MHz

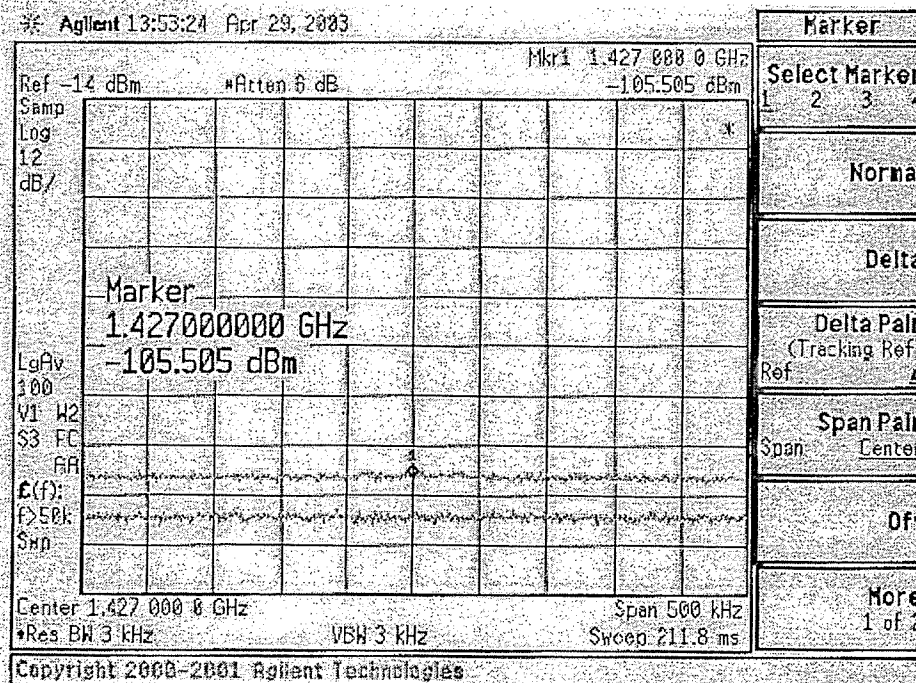
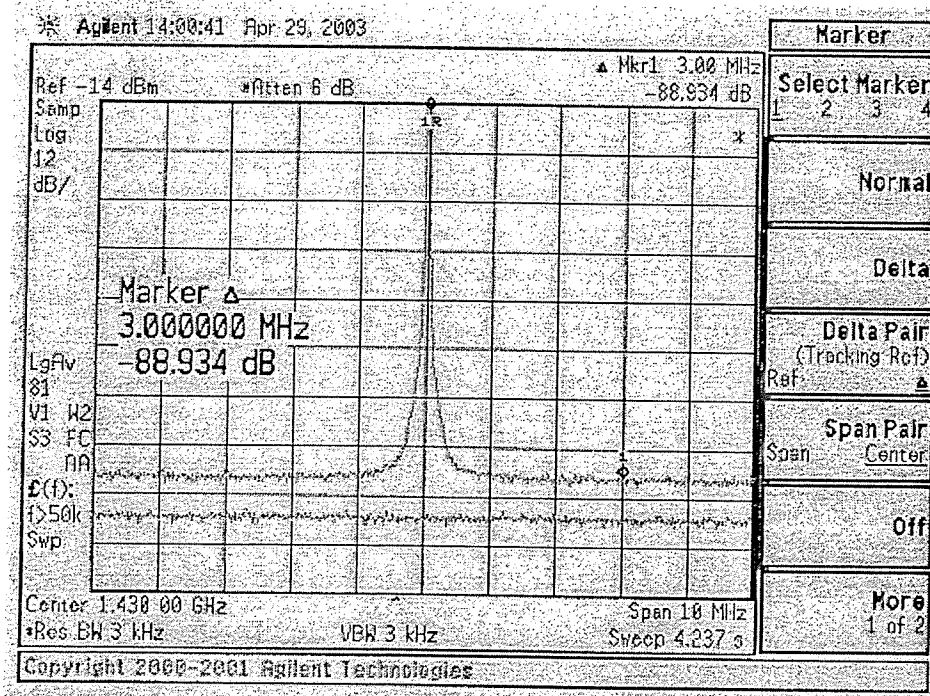

Figure 1.1.2 shows the power spectral density at the output of the Agilent modulator alone on a wider (10 MHz) span.

Fig. 1.1.2. Agilent modulator, no TWTA



A Hughes 50-W TWTA (Model 1277H) was used to amplify the phase-modulated carrier. Little degradation was observed in the spectral attenuation when passed through the Hughes TWTA. Measurements were taken at SAT, SAT-2 dB, SAT-4 dB and SAT-10 dB (input back off), and spectral attenuation at 1 427 MHz ranged from 92 to 94 dBsd. Spectral attenuation results are summarized in Table 2.

Table 2. Spectral attenuation vs. TWTA input backoff (Agilent modulator)

Input back off from SAT (dB)	Relative Output Power (dBm)	Density at 1 430 MHz (dBm/3 kHz)	Density at 1 427 MHz (dBm/3 kHz)	Spectral Attenuation (dBsd)
0	17.3	-9.0	-102.3	93.3
2	17.1	-9.2	-102.1	92.9
4	16.6	-9.6	-103.3	93.7
10	12.9	-9.4	-101.6	92.2

Figures 1.1.3a and b (next page) show compliance of the Agilent modulator-TWTA configuration against the ITU 86 dBsd requirement in the 1 420-1 427 MHz band. The peak spectral density at 1 430 MHz was measured at -6.9 dBm in a 3 kHz BW. Measured spectral attenuation against this peak ranged from 90 to 94 dBsd across the restricted band, and no spurious tones were observed.

Fig. 1.1.3a. Peak spectral density at 1 430 MHz

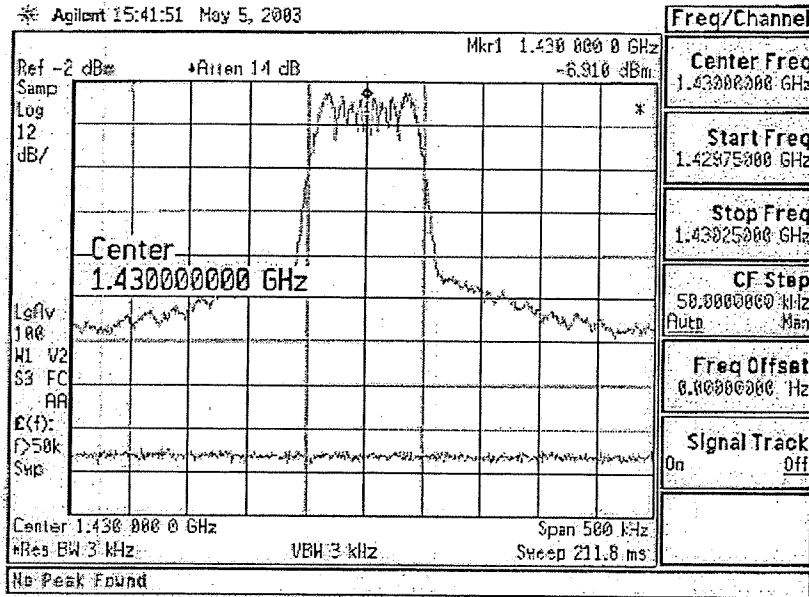
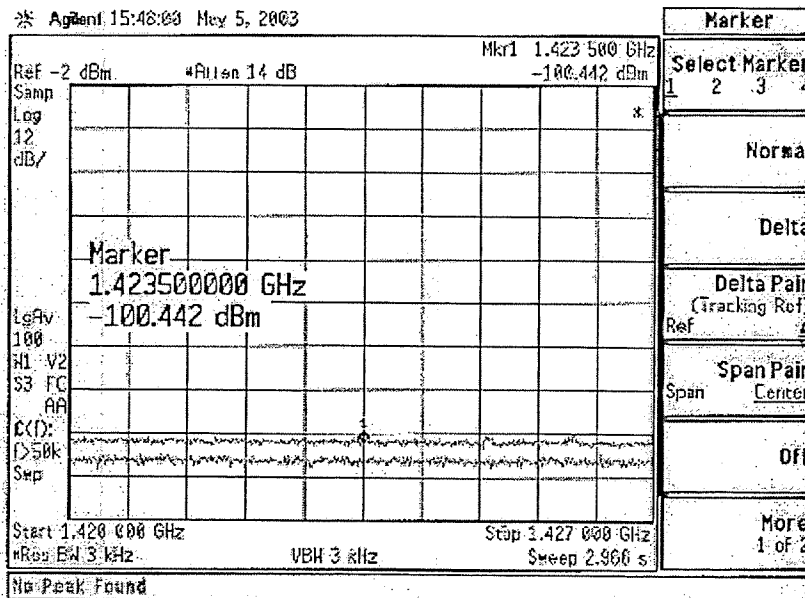

Fig. 1.1.3b. Spectral density from 1 420 MHz to 1 427 MHz



Figures 1.1.4a and 1.1.4b (next page) show medium span (10 MHz) views of the power spectral density after going through the Hughes 50-W TWTA at SAT and SAT-10dB (input backoff). We note that since the modulation waveform was not precisely constant amplitude, that spectral regrowth was noticeable at the output of the TWTA. However, the regrowth was not significant enough to violate the 86 dBsd interference requirement at 1 427 MHz, or anywhere in the 1 420-1 427 MHz band.

Fig. 1.1.4a. Agilent modulator, TWTA at SAT

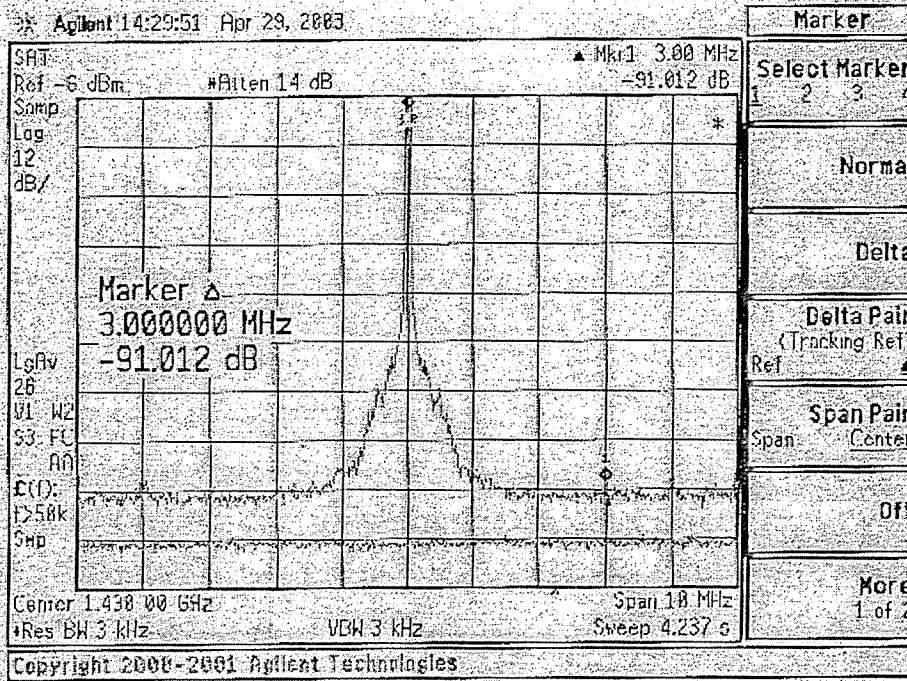
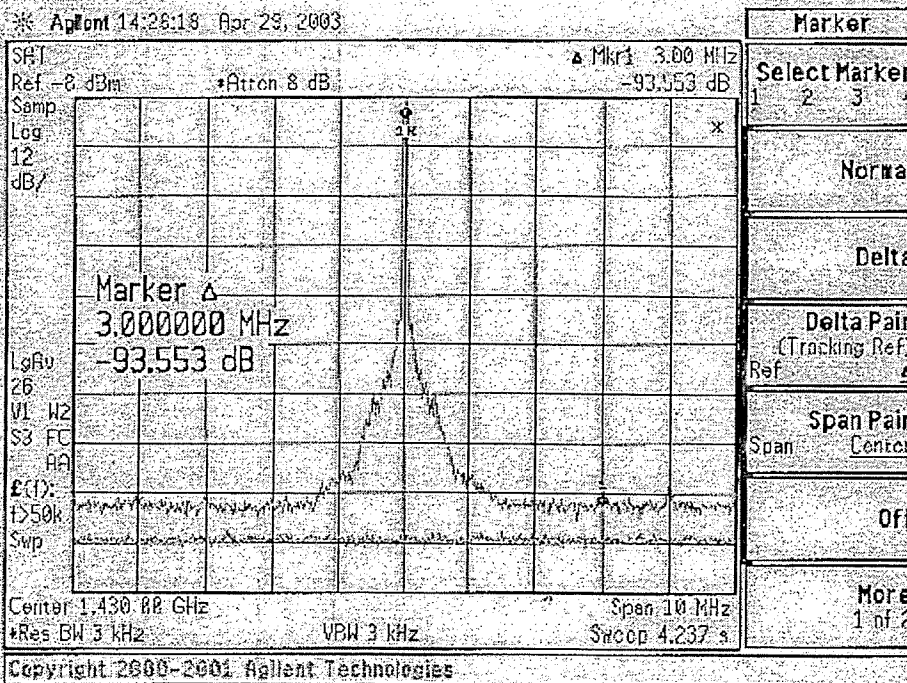

Fig. 1.1.4b. Agilent modulator, TWTA at SAT-10



Figures 1.1.5a through 1.1.8b show details of the spectral output at various input backoff levels, and do not measurably change as a function of TWTA input drive.

Fig. 1.1.5a. Agilent modulator at 1 430 MHz, TWTA at SAT

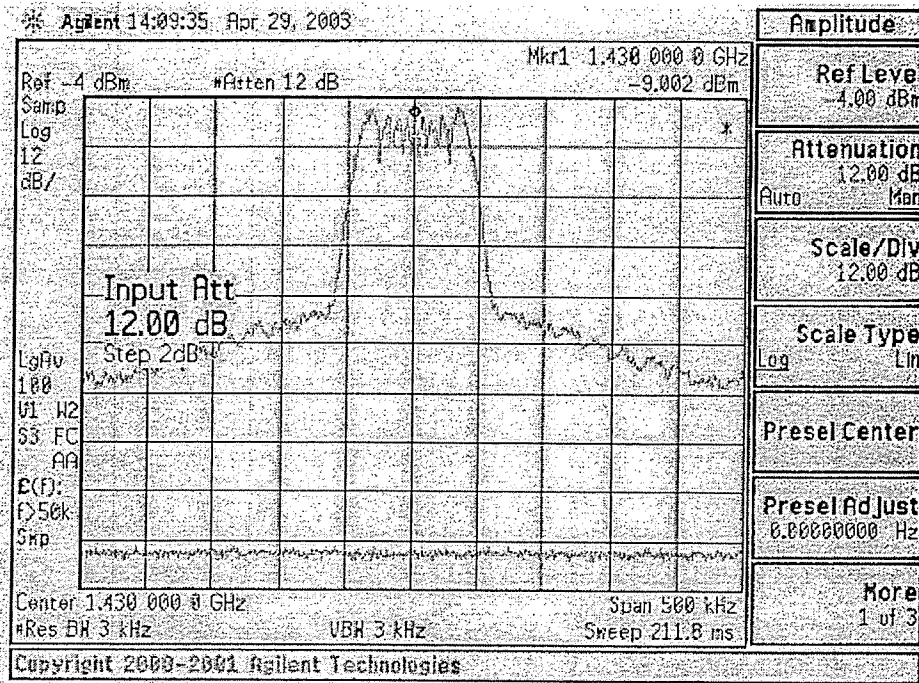

Fig. 1.1.5b. Agilent modulator at 1 427 MHz, TWTA at SAT

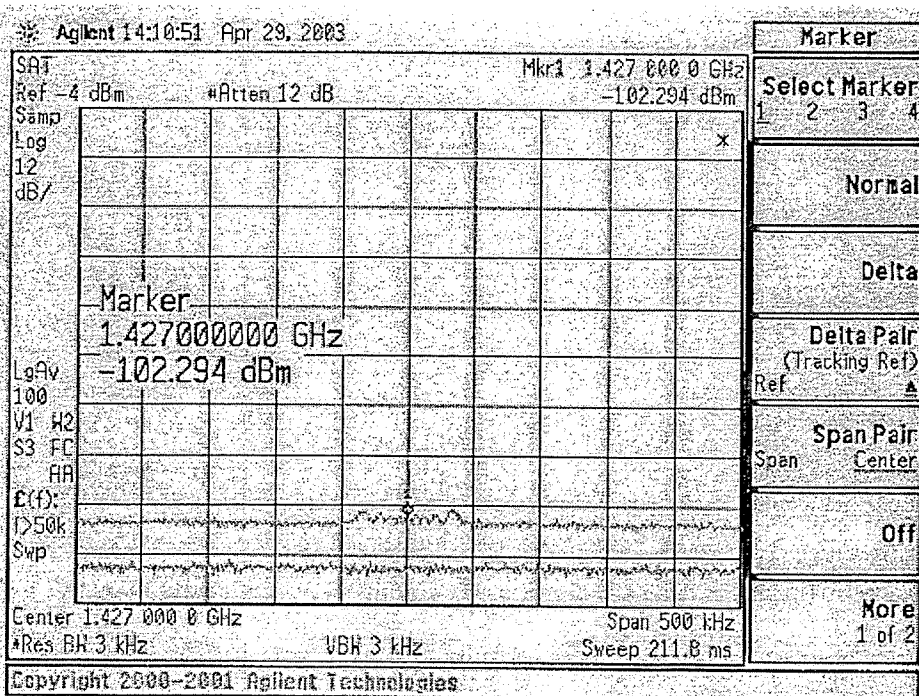

Fig. 1.1.6a. Agilent modulator at 1 430 MHz, TWTA at SAT-2

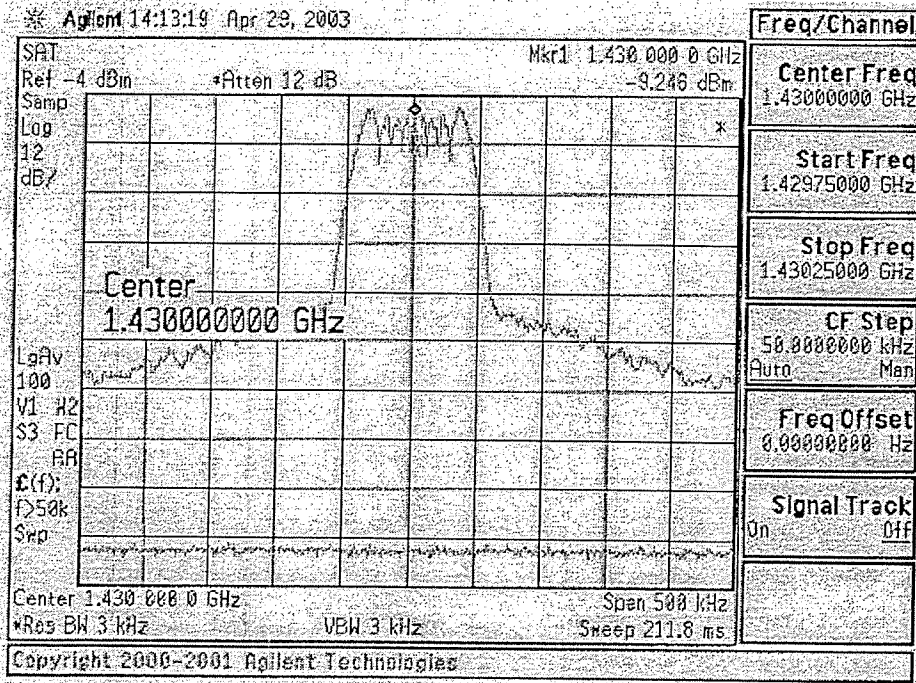

Fig. 1.1.6b. Agilent modulator at 1 427 MHz, TWTA at SAT-2

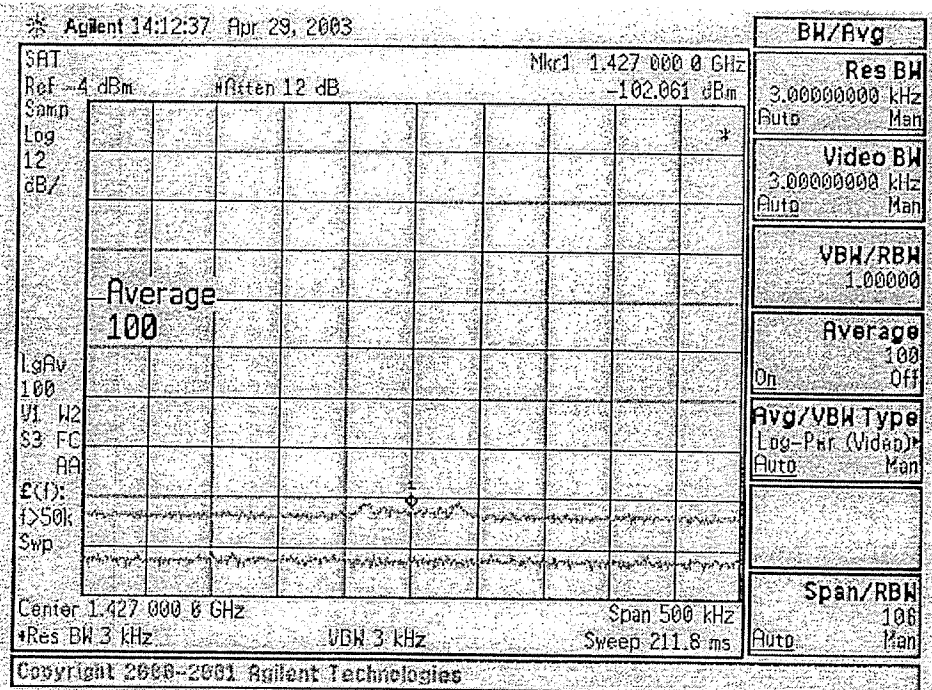

Fig. 1.1.7a. Agilent modulator at 1 430 MHz, TWTA at SAT-4

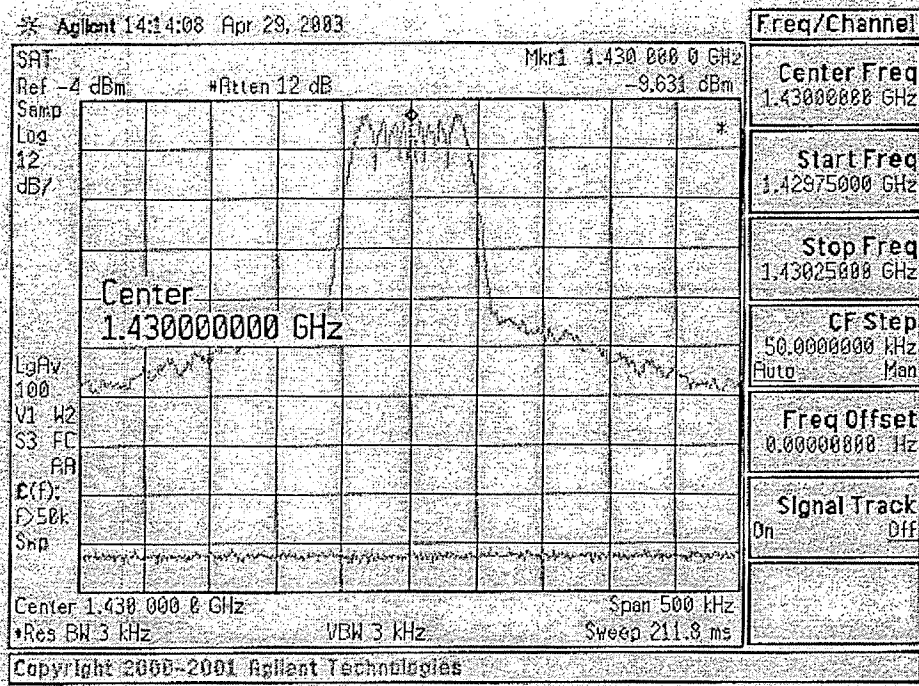

Fig. 1.1.7b. Agilent modulator at 1 427 MHz, TWTA at SAT-4

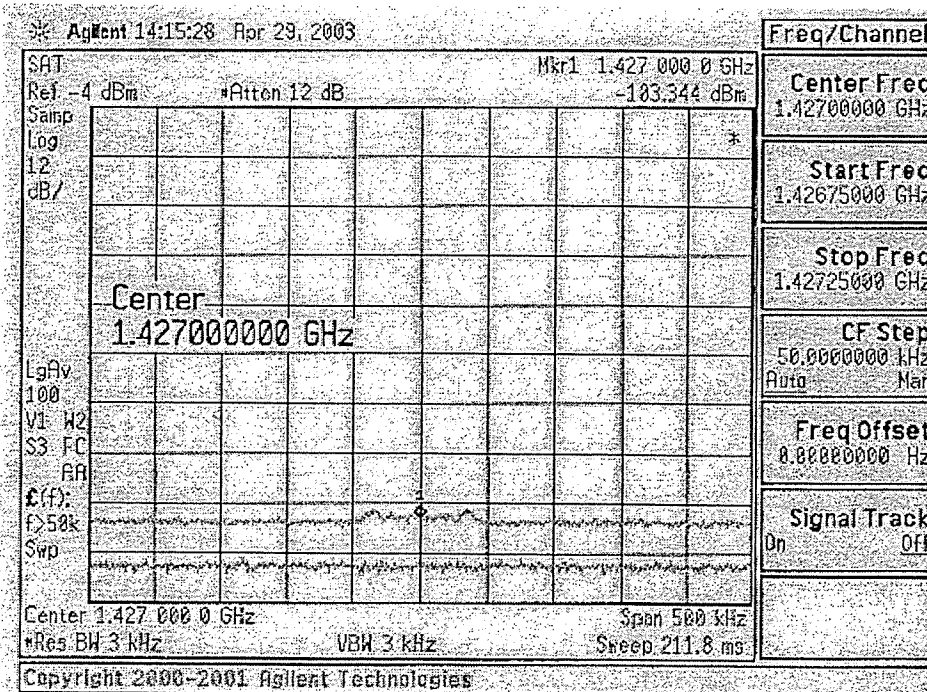

Fig. 1.1.8a. Agilent modulator at 1 430 MHz, TWTA at SAT-10

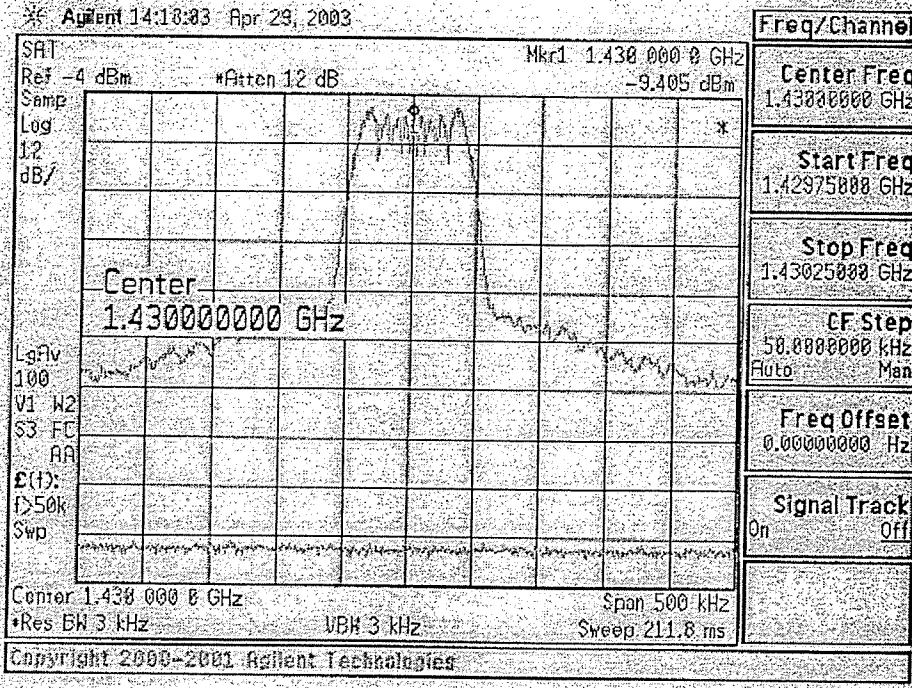
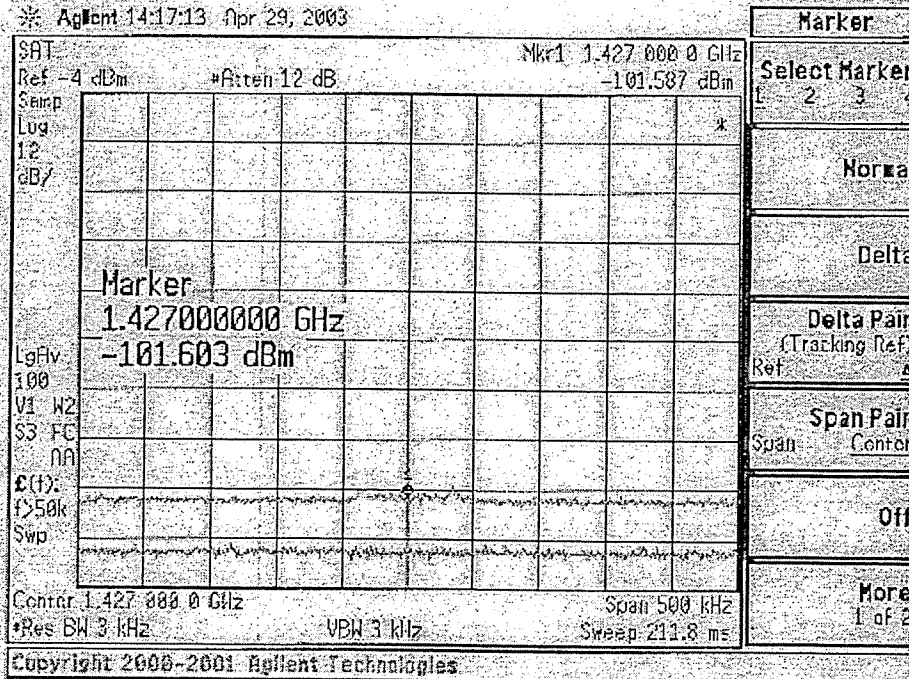

Fig. 1.1.8b. Agilent modulator at 1 427 MHz, TWTA at SAT-10



Configuration 2

A FACS modulator breadboard (S/N 002) was connected first to a WJ medium-power (100 mW) SSPA, and then to the Hughes 50-W TWTA. The FACS breadboard generated a GMSK modulated L-band carrier (at 1 430 MHz). Some spectral energy was observed at a spacing of 2 MHz and 3.6 MHz away from 1 430 MHz (Fig. 1.2.1). At close inspection, this energy appeared to be spurious images of the main modulated signal as opposed to discrete clock or frequency lines.

Fig. 1.2.1. FACS modulator #2, no TWTA

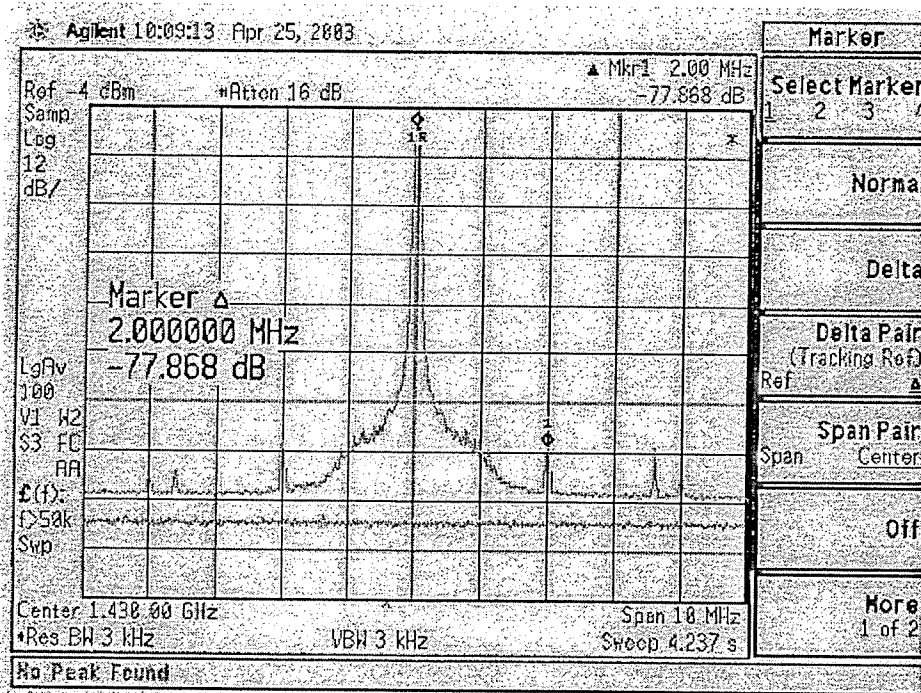

Measured spectral attenuation at the output of the FACS breadboard was approximately 90 dBsd at 1 427 MHz (relative to spectral density at 1 430 MHz). The measured GMSK spectral floor of -98.8 dBm was 6.4 dB higher than the signal-free floor of the spectrum analyser at -105.2 dBm, implying a measurement error of less than 0.9 dB. Figures 1.2.2a and 1.2.2b (next page) show the spectral output of FACS modulator #002 prior to external amplification.

Fig. 1.2.2a. FACS modulator #2 at 1 430 MHz

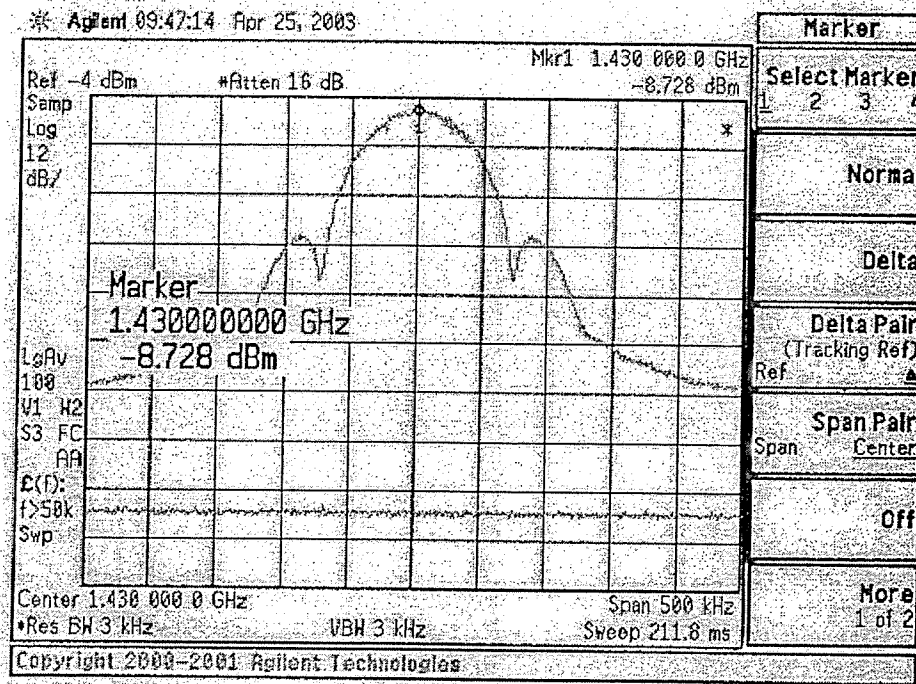
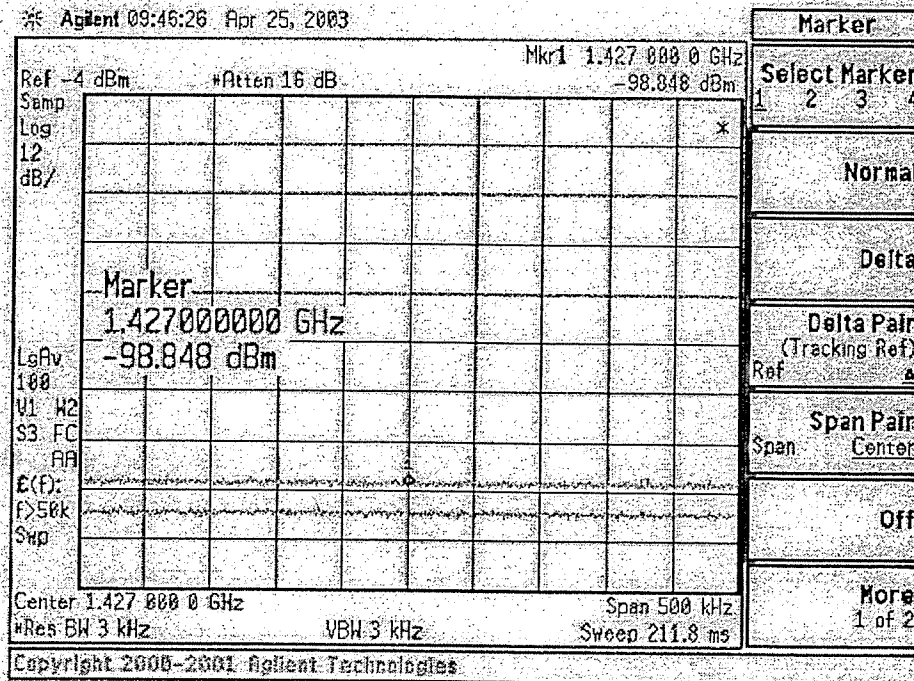

Fig. 1.2.2b. FACS modulator #2 at 1 427 MHz



Little degradation was observed in the spectral attenuation when passed through the Hughes TWTA. Measurements were taken at SAT, SAT-2 dB, SAT-4 dB and SAT-10 dB (input back off), and spectral attenuation at 1 427 MHz was still approximately 90 dBsd in all cases. Spectral attenuation results are summarized in Table 3.

Table 3. Spectral attenuation vs. TWTA input backoff (FACS modulator)

Input back off from SAT (dB)	Relative Output Power (dBm)	Density at 1 430 MHz (dBm/3 kHz)	Density at 1 427 MHz (dBm/3 kHz)	Spectral Attenuation (dBsd)
0	17.3	-7.9	-99.5	91.6
2	17.0	-7.9	-99.2	91.3
4	16.5	-9.1	-99.5	90.4
10	12.4	-7.8	-97.0	89.2

Figure 1.2.3 shows the spectrum after the TWTA operating at SAT. There is no noticeable spectral regrowth, indicating that the FACS modulation is constant amplitude, as would be expected with properly implemented GMSK.

Fig. 1.2.3. FACS modulator #2, TWTA at SAT

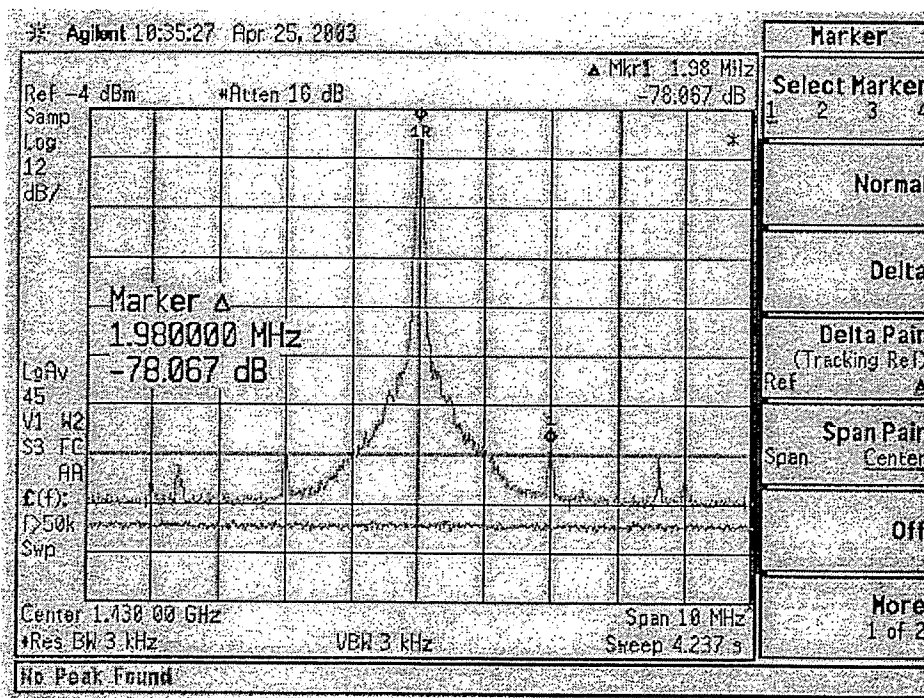

Figures 1.2.4a through 1.2.4d (following pages) show nearly complete compliance of the FACS modulator-TWTA configuration against the ITU 86 dBsd requirement in the 1 420-1 427 MHz band. No spurious discrete tones were observed, however two peaks (assumed to be modulation images) were detected at 1 426.0 MHz and 1 426.4 MHz and were approximately 0.5 and 2.0 dB above the ITU requirements, respectively. Otherwise, measured spectral attenuation ranged from 89 to 92 dBsd across the restricted band.

Fig. 1.2.4a. Peak spectral density at 1 430 MHz

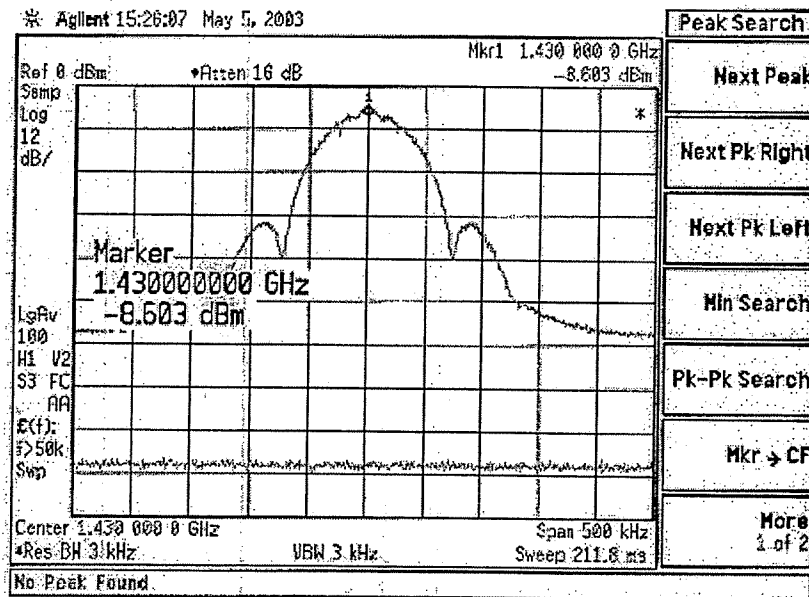

Fig. 1.2.4b. Spectral density from 1 420 MHz to 1 427 MHz

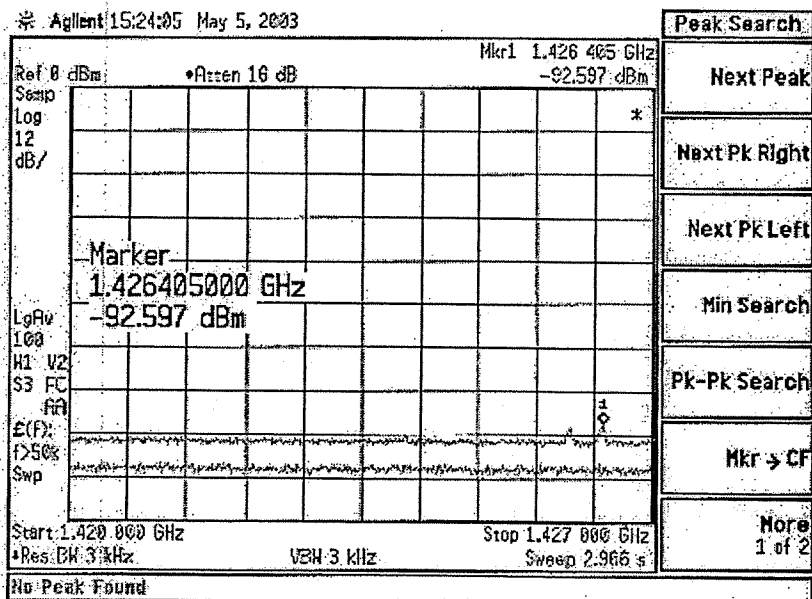

Fig. 1.2.4c. Spectral density around 1 426 MHz

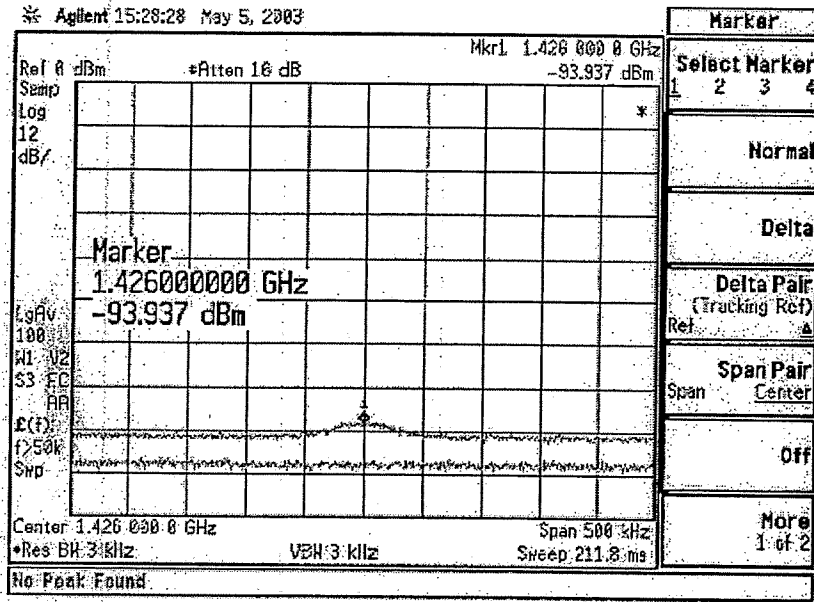
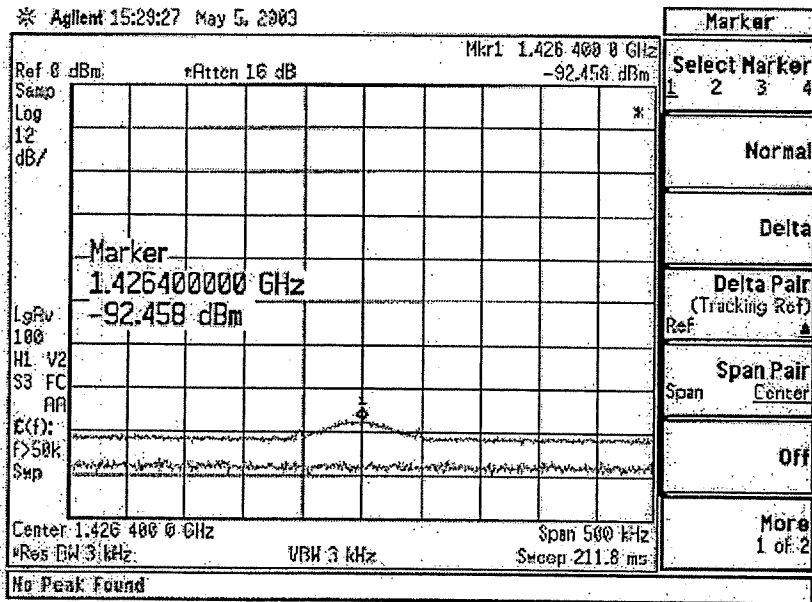

Fig. 1.2.4d. Spectral density around 1 426.4 MHz



Figures 1.2.5a through 1.2.8b on the following pages show details of the spectral output after passing through the TWTA at various input backoff levels; output results do not measurably change as a function of TWTA input drive.

Fig. 1.2.5a. FACS modulator #2 at 1 430 MHz, TWTA at SAT

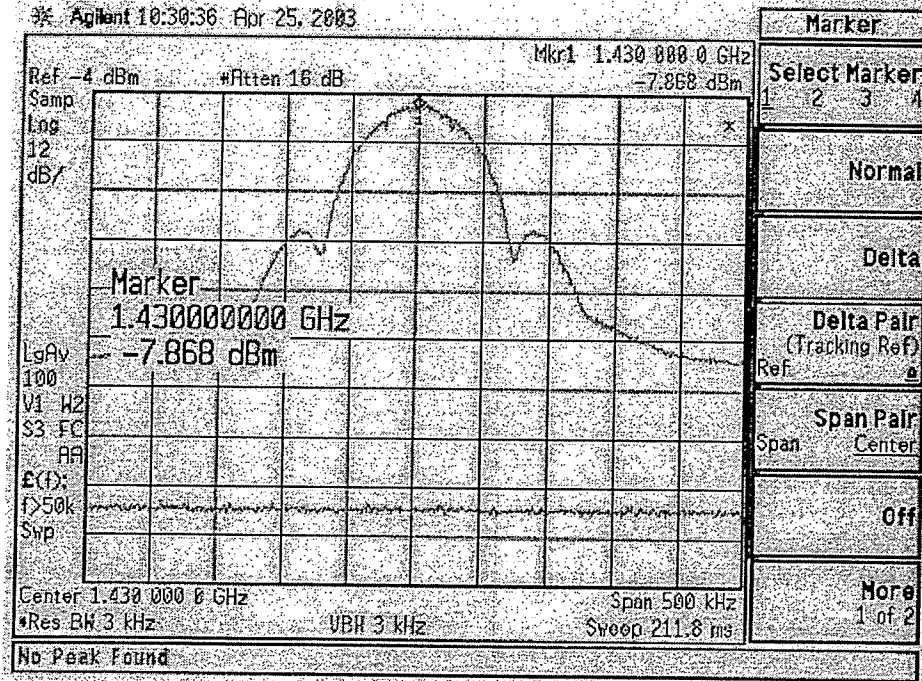

Fig. 1.2.5b. FACS modulator #2 at 1 427 MHz, TWTA at SAT

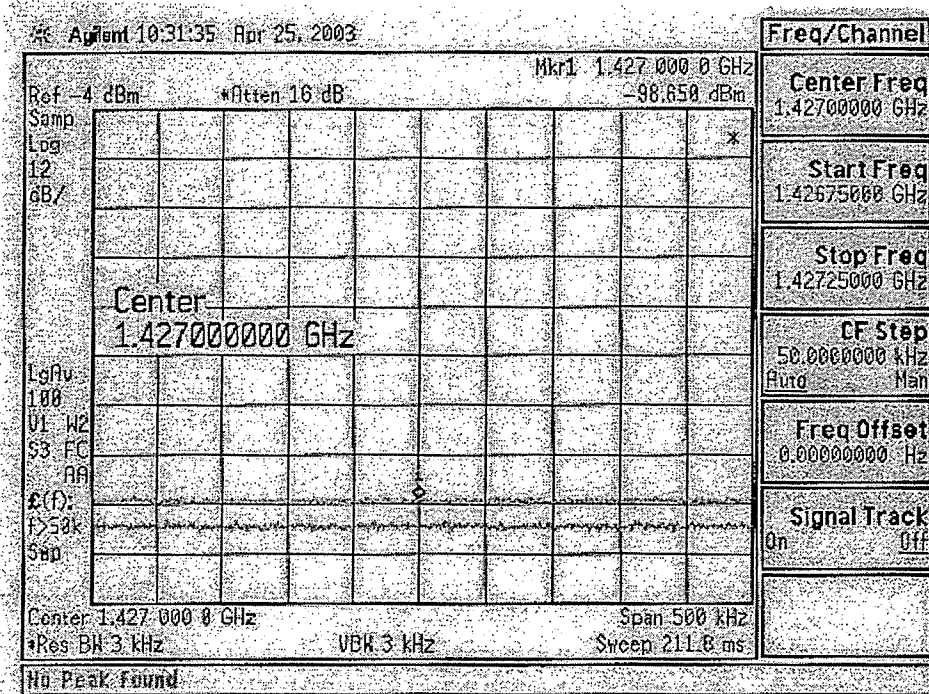

Fig. 1.2.6a. FACS modulator #2 at 1 430 MHz, TWTA at SAT-2

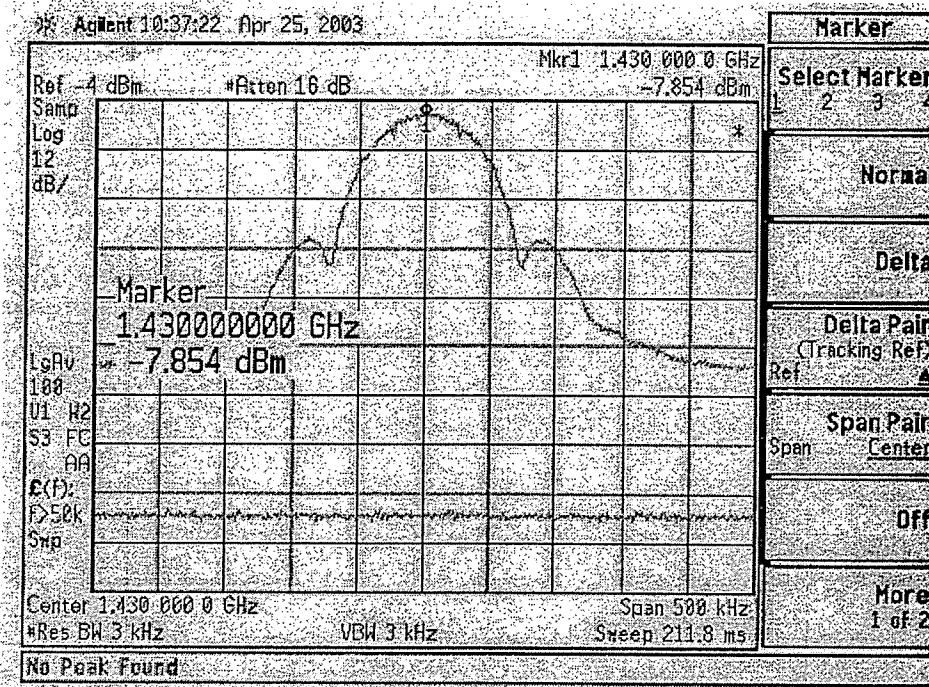

Fig. 1.2.6b. FACS modulator #2 at 1 427 MHz, TWTA at SAT-2

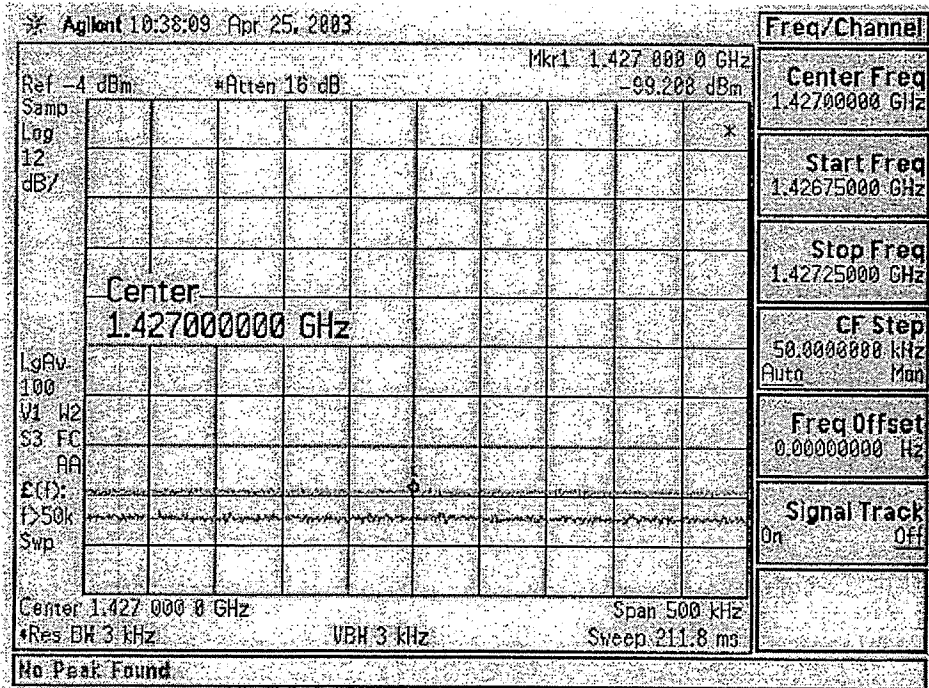

Fig. 1.2.7a. FACS modulator #2 at 1 430 MHz, TWTA at SAT-4

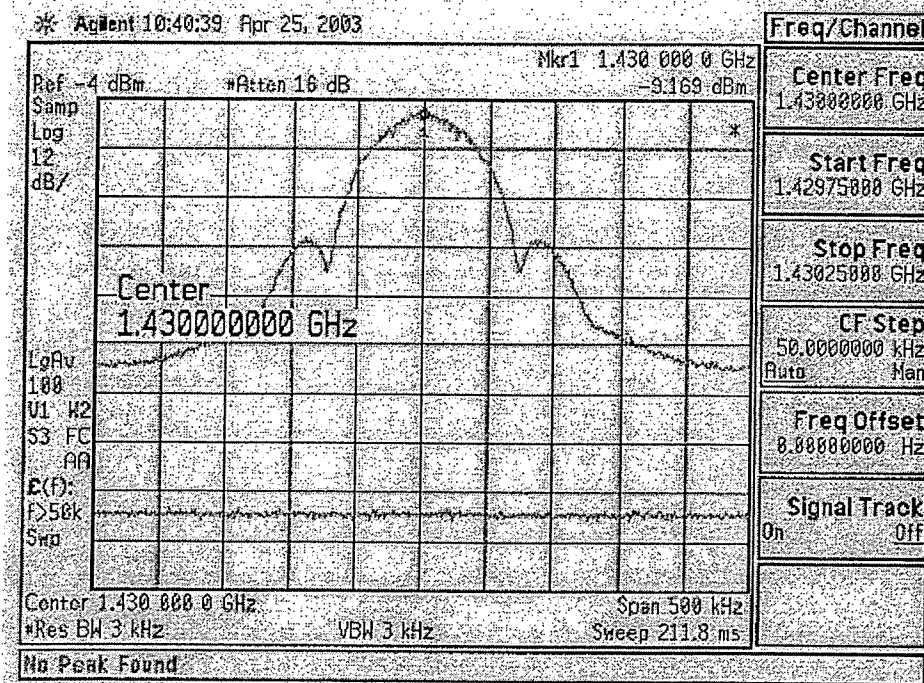

Fig. 1.2.7b. FACS modulator #2 at 1 427 MHz, TWTA at SAT-4

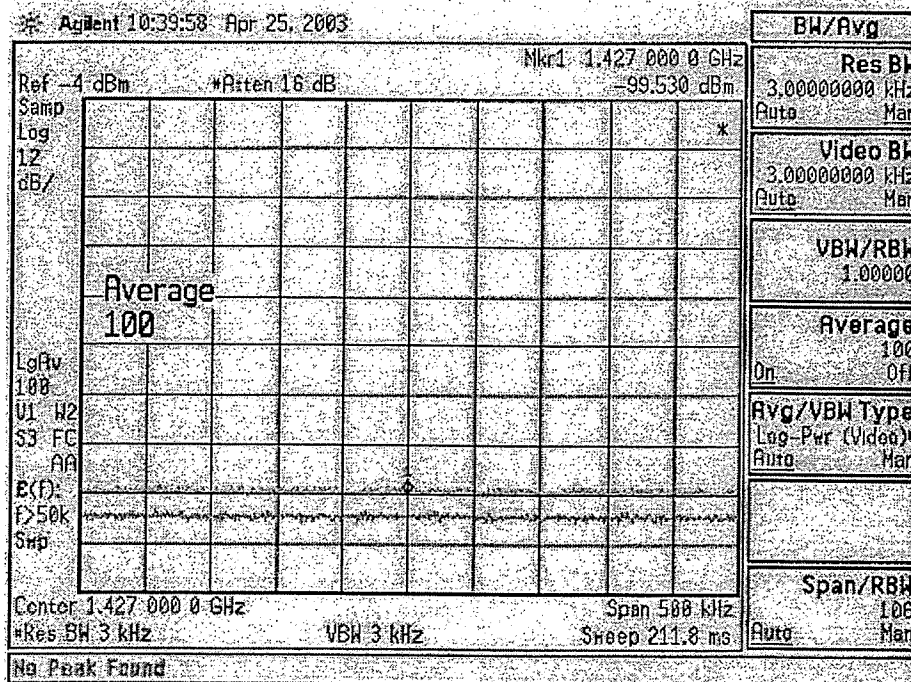

Fig. 1.2.8a. FACS modulator #2 at 1 430 MHz, TWTA at SAT-10

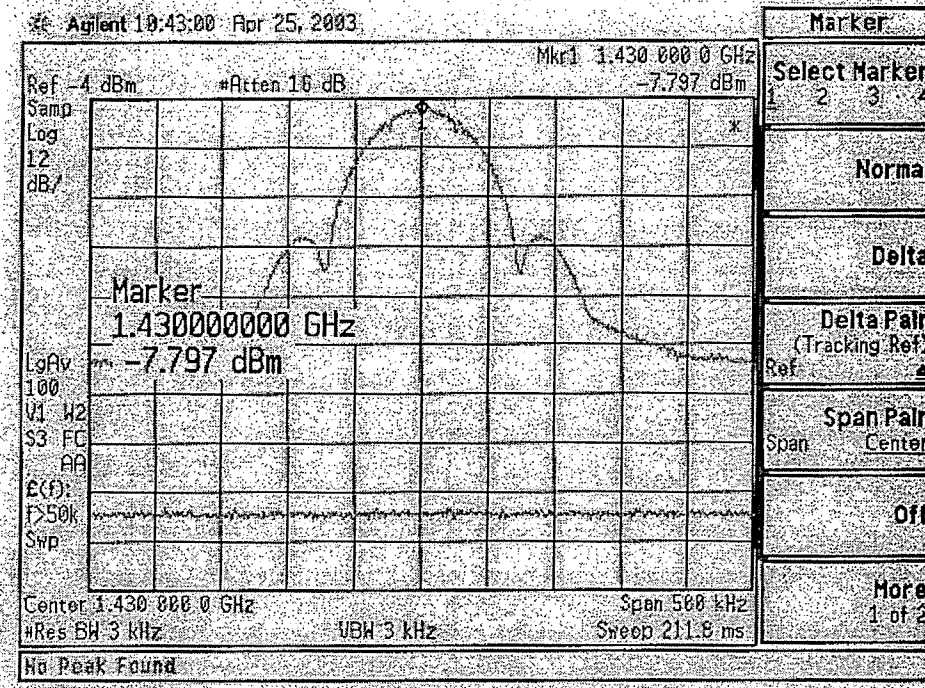
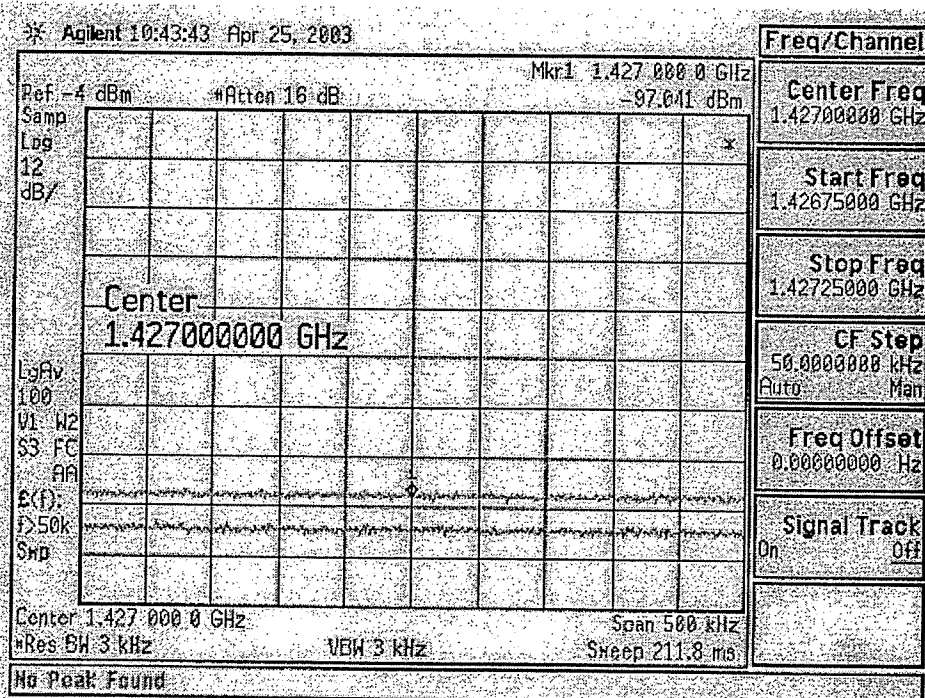

Fig. 1.2.8b. FACS modulator #2 at 1 427 MHz, TWTA at SAT-10



Similarly, little degradation was observed in spectral attenuation when passed through a medium power (100 mW) Watkins-Johnson Versa-amp SSPA. The amplifier was operated at 1 dB output compression, and spectral attenuation was 92.2 dBsd at 1 427 MHz, relative to spectral density at 1 430 MHz.

Figure 1.2.9 shows spectral output after the SSPA. This output signal appears very similar to the TWTA amplified signal (SAT) in Fig. 1.2.3, providing additional test evidence that spectral degradation through a properly operating power amplifier is minimal and does not appear to be a limiting factor in meeting ITU requirements in the 1 420-1 427 MHz band.

Fig. 1.2.9. FACS modulator #2, SSPA at 1 dB compression

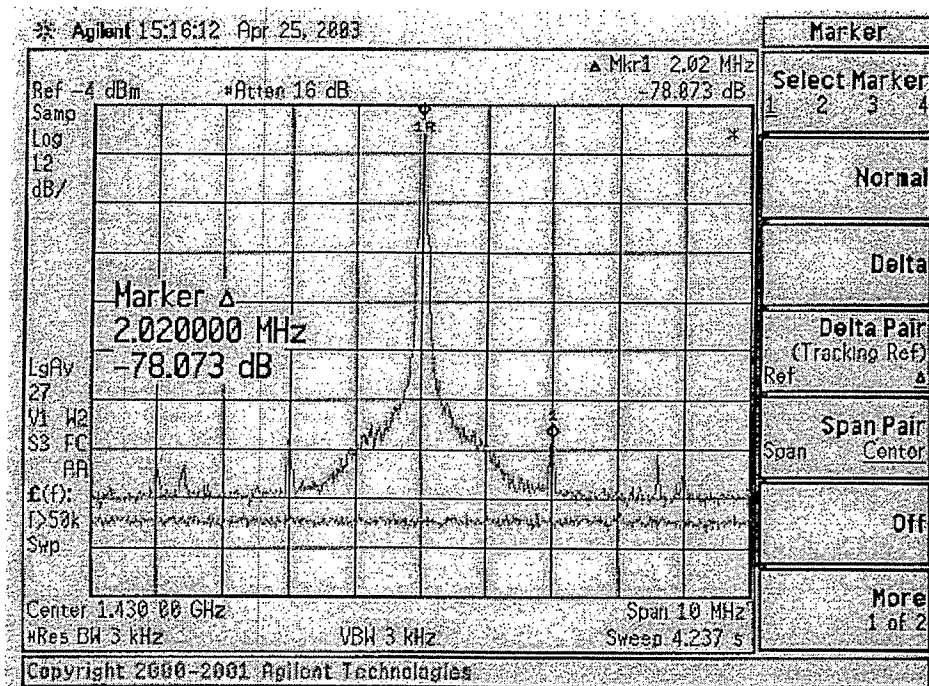

Figures 1.2.10a and 1.2.10b (next page) show details of the spectral output after passing through the SSPA operating at 1 dB output compression.

Fig. 1.2.10a. FACS modulator #2 at 1 430 MHz, SSPA at 1 dB compression

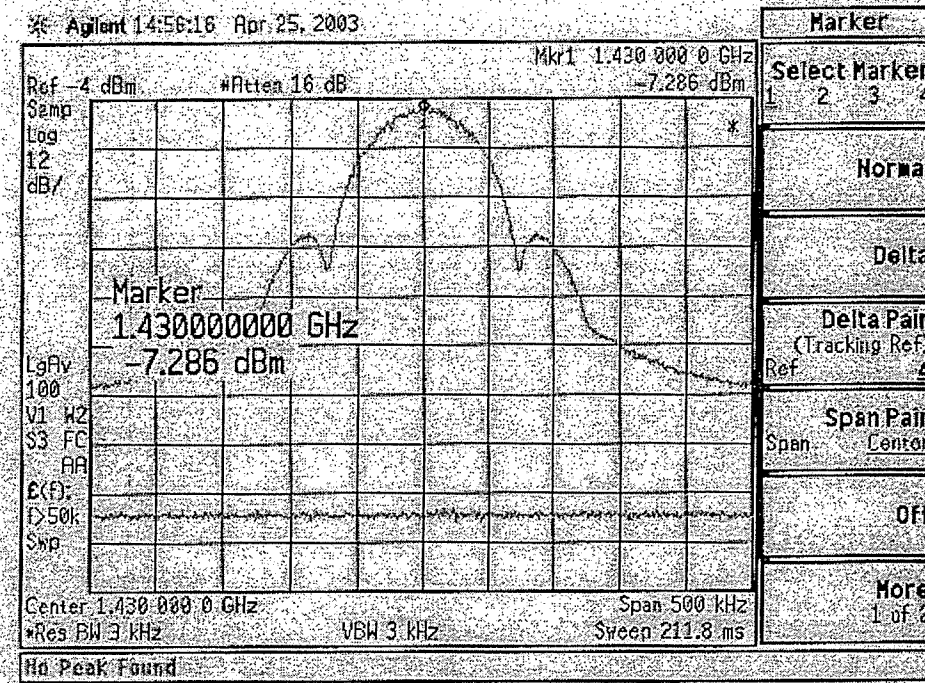
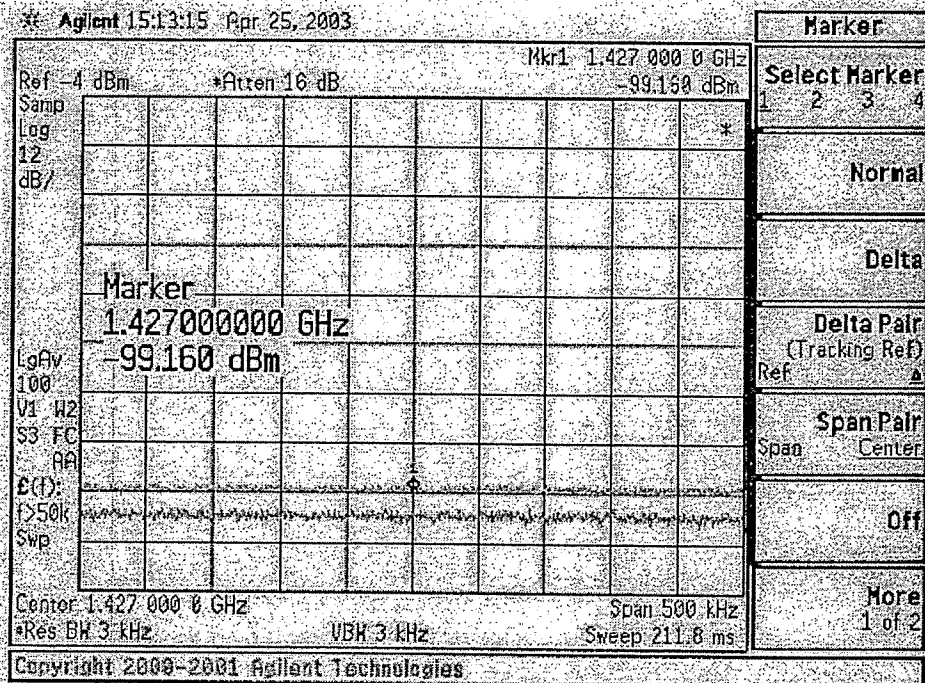
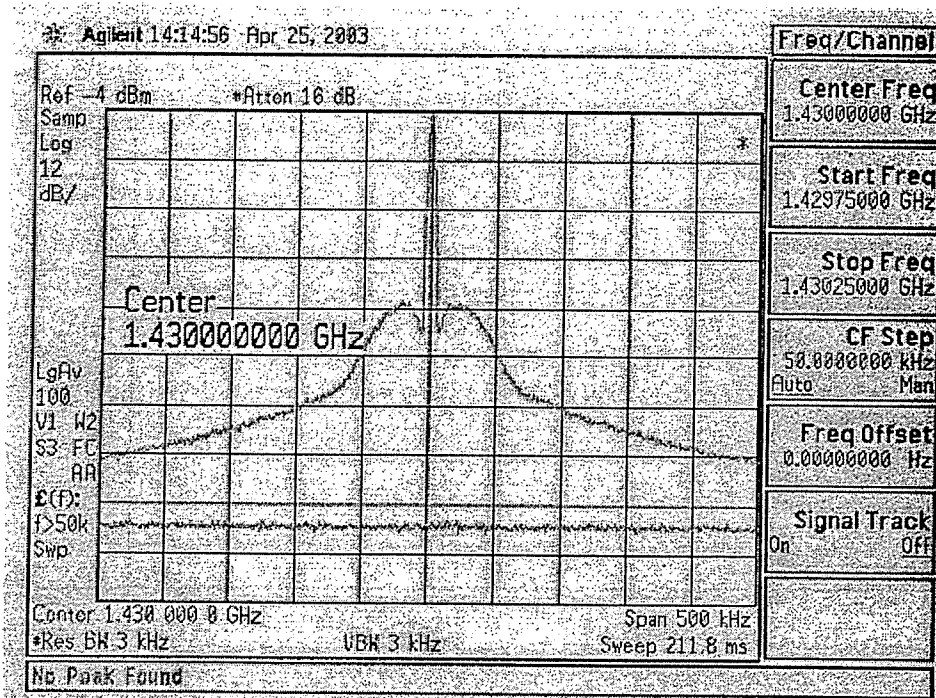

Fig. 1.2.10b. FACS modulator #2 at 1 427 MHz, SSPA at 1 dB compression



An initial attempt was made to observe the demodulated GMSK eye pattern, to determine if any obvious corruption of the data was present. An unmodulated 1 430 MHz carrier (Fig. 1.2.11) was located at SMA port J16 on the FACS breadboard, and it was used to demodulate the modulated signal back to baseband. However it was difficult to observe the eye pattern without a clock recovery circuit to consistently trigger an oscilloscope, and this measurement was postponed until a Vector Signal Analyser or other appropriate test equipment could be located.

Fig. 1.2.11. FACS modulator #2 LO at 1 430 MHz



As a quick alternative to the eye pattern test, I and Q recovered data was sent into an oscilloscope operating in X-Y mode. A clean, generally constant amplitude X-Y pattern was recovered, consistent with GMSK modulation. No discernable degradation of the constant amplitude circle was observed after passing through the TWTA power amplifier at SAT. A plotted representation of the recovered I vs. Q pattern is shown in Fig. 1.2.12 on the next page.

Fig. 1.2.12. Recovered I vs. Q

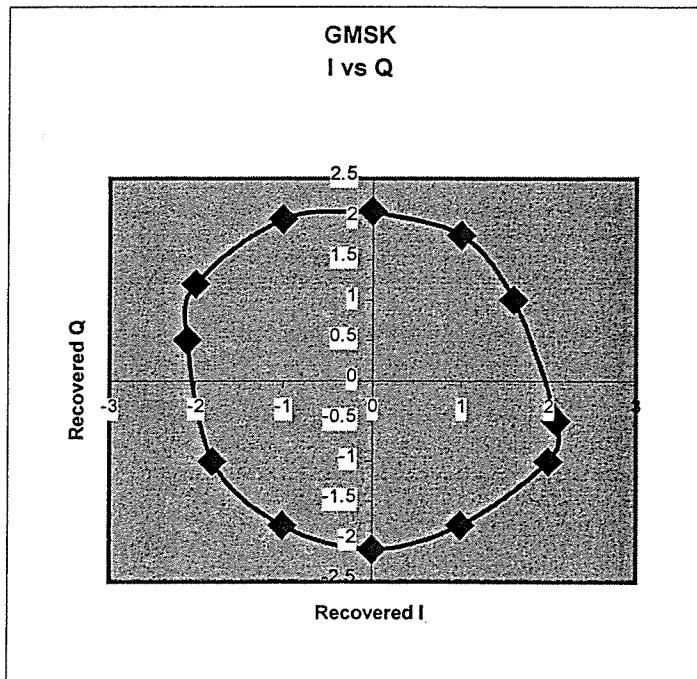

Fig. 1.2.13a. FACS modulator #1

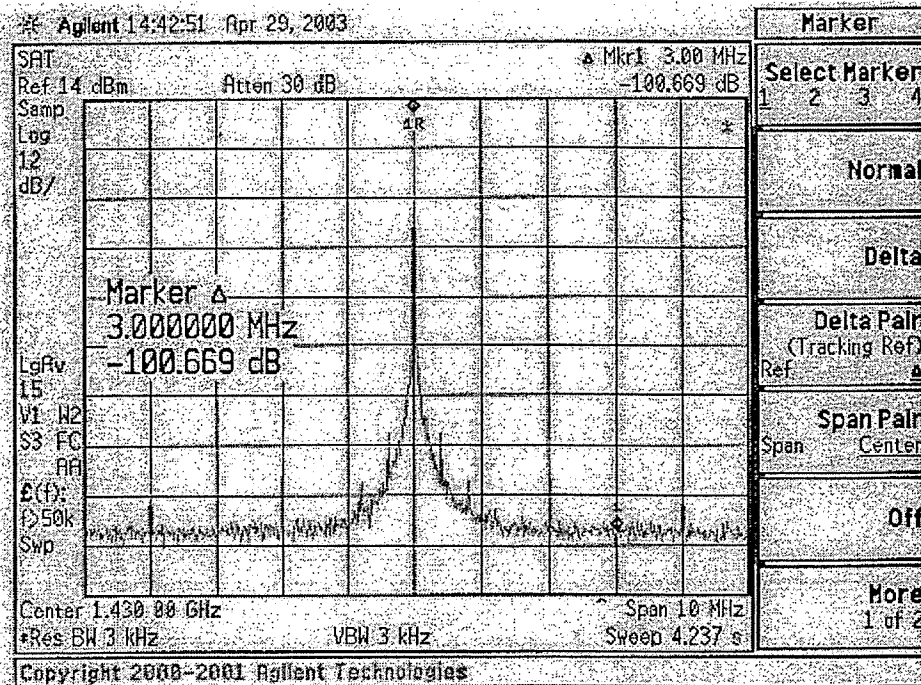
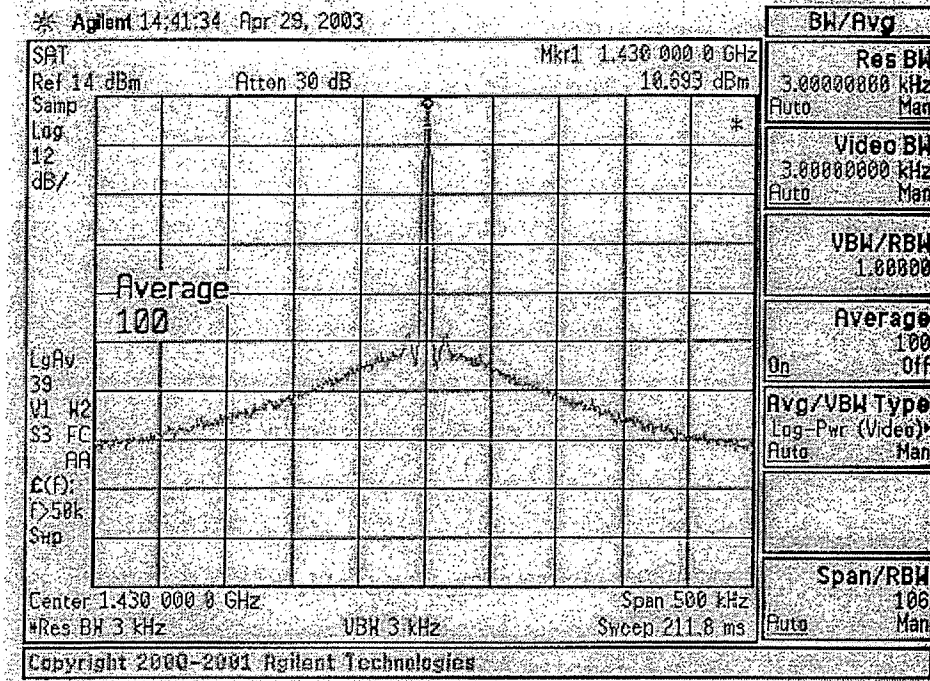

Fig. 1.2.13b. FACS modulator #1 at 1 430 MHz



Task 2. Assert that the technology is available to implement a spaceborne transmitter with a dynamic range of greater than 86 dBsd. The use of a transmit filter in order to meet this requirement is allowed.

Task 2 Results

A summary of path-to-flight issues (Table 4) addresses potential beginning-of-life (BOL) performance issues as the modulator-transmitter design evolves into space-qualified hardware from the breadboards measured on this task.

Table 4. Summary of path-to-flight issues

Building Block	Comments	Projected performance delta
L.O. carrier	Breadboards use either lab test equipment synthesizer or RFIC source; flight equivalent likely would use crystal oscillator with multiplier chain	No expected degradation
Digital modulation	Company breadboard uses 16-bit dual DACs; FACS board uses 10-bit DACs, which are available as flight qualified	No expected degradation
RF upconverter/modulator	Breadboard uses RFIC or RF mixers and hybrids; flight equivalent would use similar technology	No expected degradation
Output power amplifier	Breadboard uses 50-W TWTA; flight equivalent would use smaller TWTA or SSPA	No expected degradation
Pre- and post-amplifier filter	None used in breadboard measurements; high power flight filters from other satellite programs show availability if necessary	Additional 30 dB of positive margin towards ITU spectral density interference specification

A small number of building block components can be assumed to have the potential to contribute to degradation of spectral density attenuation of a GMSK modulator-transmitter as a flight hardware configuration evolves from the breadboard designs tested at our facility.

In discussions with a US licensee regarding likely limitations on the mechanical design of the flight modulator-transmitter, we understand that the anticipated Russian booster vehicle which will be used to launch the FACS satellite has sufficient capacity to minimize the need to impose stringent size (volume), weight and power constraints. The result of this excess launch capacity is a positive simplification of the flight hardware design, as a wider selection of components becomes available to choose from.

L.O. carrier

Tested hardware configuration #1 used Agilent test equipment synthesizers to generate the L-band carriers. Agilent synthesizers typically have excellent carrier phase noise performance, above what would be expected in a flight LO. However the FACS breadboards (configuration #2) use a commercial quality RFIC synthesizer, and the measured GMSK spectral performance did not appear to be limited by the performance of that LO source (synchronized against a laboratory

10 MHz standard), as spectral attenuation performance was very similar in all configurations measured at our facility. In the flight hardware configuration, the RFIC would be synchronized against a received GPS (atomic clock) reference, which would have better long-term stability than a lab standard.

Specified and measured performance of space quality oscillators indicate that at a distance of 3 MHz from the centre frequency, the phase noise of a multiplied crystal oscillator should typically be better than -140 dBc, which would provide greater than 40 dB of margin over what is needed to avoid contributing to degradation of the GMSK spectrum.

Digital modulation

The projected 100 kbps data rate is well within the range of available space-qualified digital ICs in bipolar or CMOS technologies, thus the translation of the digital designs used in the GMSK breadboards to flight qualified implementations is straightforward, with the exception of the 16-bit dual D-to-A converters used in the output stage of our company's testbed digital modulator.

The AD9731 12-bit high-speed DACs used in the FACS breadboard modulator are available as space-qualified devices for use in the flight modulator design, thus no degradation of the performance of the digital subsection is expected as compared to the tested FACS breadboard.

RF upconverter

The Agilent signal generator and FACS breadboard both utilize RFIC modulators. In the case of the FACS RFIC modulator (AD8346) a path to flight is expected to be available through the specific vendor's space qualified fabrication process. In the worst case, this component may require individual qualification if no equivalent heritage part built in the same fab process is located before the design is fixed.

Output power amplifier

The Hughes 50-W TWTA used in the testing of all modulator breadboards has extensive flight heritage from the Boeing EDD (formerly Hughes) organization. FACS transmitter requirements are understood to be significantly lower (1-W space, 10-W ground) than the tested TWTA, however the measured performance of the spectral interference pre- and post-TWTA shows that there is insignificant performance degradation of the GMSK waveform in this major component, even at the higher (50-W) power level.

1-W or 10-W L-band solid-state amplifiers were not readily available to support these tests; however no significant difference in degradation is expected if SSPAs were selected for use over TWTAs. The 100 mW SSPA that was tested with the FACS breadboard had slightly less spectral interference degradation as compared against the performance seen with the 50-W TWTA.

Pre- and post-amplifier filter

No tests were performed with post-amplifier, high power filters, as all tested configurations met the 86 dBsd spectral interference requirement without filtering (other than the two 0.5 dB and 2.0 dB violations noted previously in the breadboard FACS modulator). Minor bandstop filtering at the low power output of the modulator can easily be implemented to meet the ITU interference requirements, as no spectral degradation was observed through either the TWTA or SSPA. This extra filtering would provide margin against the ITU requirements over the mission life.

If high power filtering was necessary after the power amplifier, we have direct experience in specifying high-power, flight bandpass filters at a similar L-band frequency for another satellite program. Based on interpolation of existing high-power filter specifications and the same vendor's response to specific FACS requirements, an additional minimum attenuation of 30 dB (nominal vendor specs) could be achieved at 1 427 MHz, the closest worst-case spacing from a modulated downlink signal centred at 1 430 MHz. For the FACS ground-based uplink configuration, the vendor specifies a minimum attenuation of 42 dB at 1 400 MHz, the closest worst-case spacing from a modulated signal centred at 1 392 MHz.

Test relevance to proposed 1 390-1 392 MHz uplink

All laboratory tests were performed at a modulated carrier of 1 430 MHz, looking at potential interference in the 1 400-1 427 MHz band reserved for radio astronomy. There was no rise in interference observed up to 30 MHz away from the modulated carrier, and there is a reasonable expectation that an identical GMSK-modulated carrier operating on the low side of the 1 400-1 427 MHz band would perform similarly (i.e. comply with the 86 dBsd requirement). The two differences between the proposed uplink and downlink signals are in separation distance from the 1 400-1 427 MHz band, and amplifier power. A 1 300-1 392 MHz uplink would have a larger guardband (8 MHz vs. 3 MHz) to the radio astronomy band, leading to simpler filtering requirements. The proposed uplink of 10 W is five times lower than the tested 50 W laboratory signal. No spectral regrowth was observed in the 1 430 MHz tests, thus none is expected with a 10 W power amplifier.

Task 3. Address reliability issues related to ensuring that the required level of performance is achieved over a seven-year period when on orbit.

Task 3 Results

Well-understood and documented environmental and aging effects affect the long-term, on-orbit satellite payload performance. The breadboard test results performed thus far by our company require extrapolation to ensure compliance with ITU requirements at the end of the seven-year mission life (EOL) due to normal aging effects and exposure to radiation, temperature and the space environment.

The same process through which components are selected for the flight design is also critical to ensuring compliance with overall performance specifications at EOL.

Analog components (including oscillator)

Long-term stability of the master crystal oscillator in space environments is well understood and generally not a problem in the satellite if specified prior to acquisition for flight. Typical frequency drift of less than 10^{-8} is reasonable to expect and well within the necessary performance to stay within ITU requirements. Phase noise degradation does not occur to the levels where it would impact spectral interference, other than in the event of catastrophic component failure.

Digital components (GMSK shaping)

Digital circuits have less sensitivity to aging and temperature effects as compared with analogue circuits, and most necessary digital circuit building blocks are available in space qualified versions. The most common problem with digital circuitry in space is the effect of single event upsets (SEU) due to radiation. Where necessary, the selection of rad-hard digital devices (such as processors, memories and gate arrays) or the use of selective mechanical shielding provides the means to mitigate sensitivity to radiation. The FACS digital modulator will be used to process a constant flow of data, and as such is much less sensitive (from a system and practical user standpoint) to the effects of SEUs.

RF components (upconverter)

The most common degradation seen in RF components is a loss of gain in active amplifiers as characteristics change over time and exposure to radiation. The satellite industry mitigates these effects upon the overall system through the choice of properly designed and tested components with minimal sensitivity to these changes.

Power components

As with the above RF components, the satellite industry has much experience in designing and producing power amplifiers for 10-15 year life in orbit, and a graceful degradation is expected in a properly designed power amplifier. The use of redundant blocks mitigates unexpected random failures due to components or workmanship issues.

APPENDIX A TO ANNEX 2

Spectral Interference Test Configuration

Figure A1. Test configuration

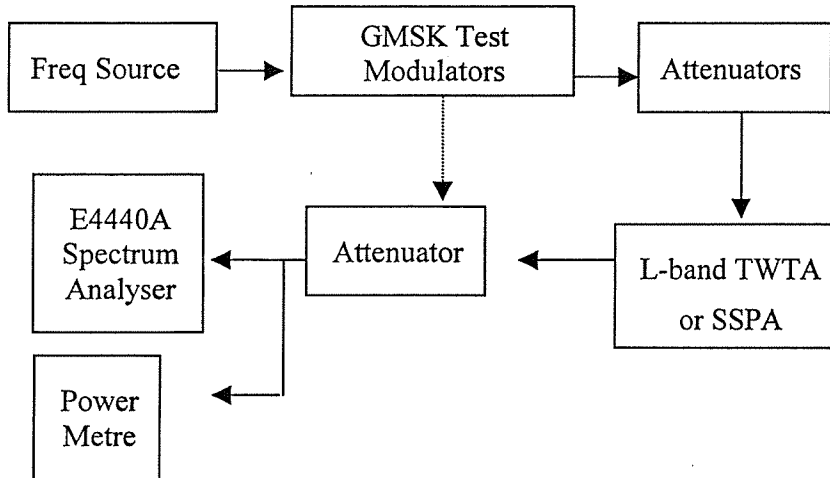

E4440A Spectrum Analyser settings

Parameter	Setting	Comment
Internal Attenuation	14 dB typ	Adjusted for maximum analyser input signal before "IF limiting" warning
Ref Level	-6 dBm	Adjusted to keep peak power density of signal at 1 430 MHz below top of screen
Span	500 kHz, 10 MHz or 27 MHz	500 kHz span used for close-in measurements to minimize measurement time (100 averages used)
Res BW	3 kHz	Set lower than "auto" to increase measurement range
Video BW	3 kHz	Set lower than "auto" to increase measurement range
Sweep	Auto	
Averaging	100	
Vertical Scale	12 dB/div	Increased from 10 to 12 dB/div to allow potential 120 dB range to be displayed

These nominal analyser settings were determined through experimental testing, reference to Agilent application notes and discussions between Ralph Crenshaw of FACS and us on 14 April 2003. Mr. Crenshaw had made spectrum measurements at FACS previously with similar test equipment.

APPENDIX 3

Satellite and Ground Station

Modulator and Upconverter Architecture

1.0 Transmitter Architecture

Figure 1 shows the architecture of the feederlink transmitter architecture. The architecture is a single conversion transmitter using a direct up-conversion quadrature modulator. The Local Oscillator is at carrier frequency.

Figure 1 Transmitter Architecture

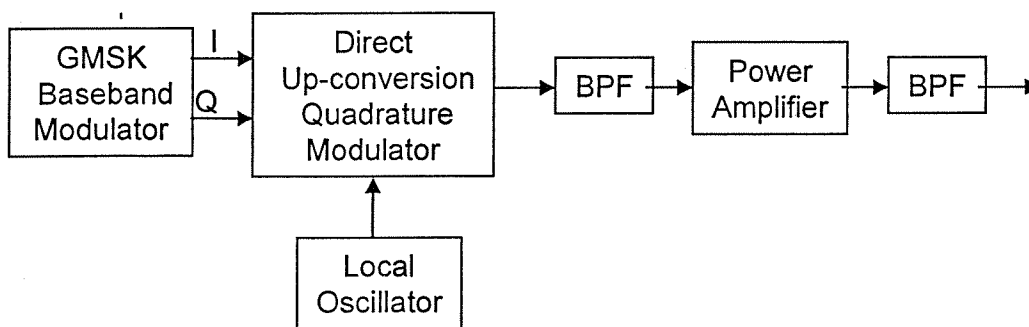

2.0 GMSK Baseband Modulator

Figure 2 shows the architecture of the GMSK baseband modulator.

Figure 2 GMSK Baseband Modulator

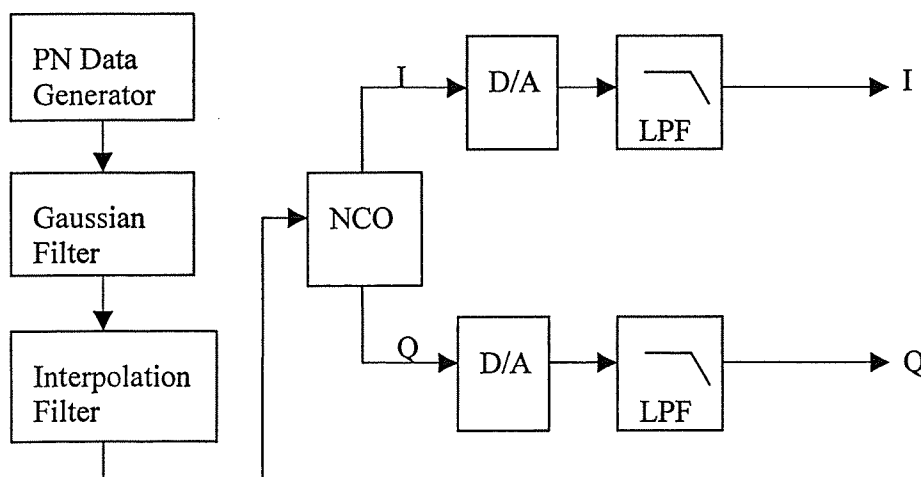

The modulator generates baseband GMSK using a FPGA (Field Programmable Gate Array). First a pseudo-random data sequence is generated and then filtered using a Gaussian filter with a filter constant of $BT=0.5$. The filter is implemented as a FIR with 17 taps and 12-bit coefficients. The result is then interpolated 64:1 using a 3-stage cascaded integrator comb. The result is input to a numerically controlled oscillator, which then generates the resulting inphase and quadrature (I&Q) outputs. The NCO has a 32-bit phase accumulator, and has a 512-deep lookup table for sine and cosine functions. The GMSK modulation dimensions are as follows:

pn_sreg[15]	shift register for PN sequence
p_incr[12]	phase increment before filtering
filter_output[16]	phase increment after Gaussian filtering
mod_phase[32]	interpolated phase increment
tx_freq[24]	fixed frequency offset (settable by command)
nco_in[32]	input to NCO for GMSK
i_gmsk[12]	inphase output from NCO for GMSK
q_gmsk[12]	quadrature output from NCO for GMSK

Clock rates used are as follows:

PN generation	100 kHz
Gaussian filter	800 kHz
GMSK NCO	51.2 MHz

The intent is for the spurious content of the digitally created GMSK baseband signal to be below the spurious free dynamic range of the D/A convertors in order to minimize the amount of analog filtering required.

3.0 Local Oscillator

Figure 3 shows the architecture of the local oscillator.

Figure 3 Local Oscillator

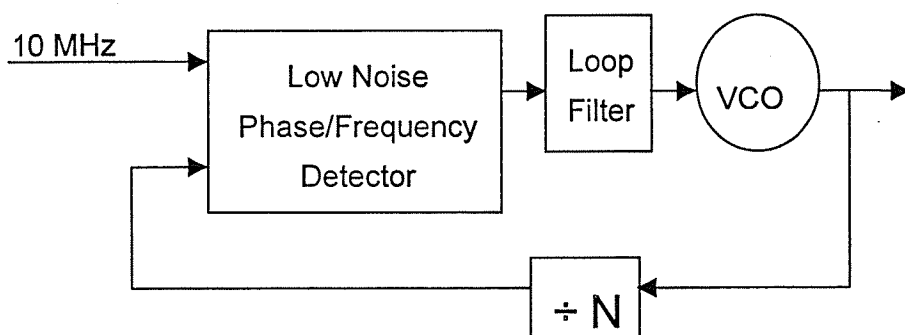

The local oscillator uses a PLL that accepts a 10 MHz frequency reference from the spacecraft bus and multiplies this frequency to the RF carrier frequency. The 10 MHz frequency reference is phase locked to the spacecraft bus GPS receiver and thus has no long term drift.

4.0 Up Converter

Figure 4 shows the architecture of the direct up-conversion quadrature modulator. The local oscillator (LO) frequency is at carrier frequency.

Figure 4 Direct Up-conversion Quadrature Modulator

