



**FCC CFR47 PART 22 SUBPART H
FCC CFR47 PART 24 SUBPART E**

CERTIFICATION TEST REPORT

FOR

GSM/WCDMA PHONE

MODEL NUMBER: LG329G, 329G

FCC ID: ZNF329G

REPORT NUMBER: 15I20528-E1 REVISION A

ISSUE DATE: MAY 28, 2015

Prepared for

**LG ELECTRONICS MOBILECOMM U.S.A., INC
1000 SYLVAN AVENUE
ENGLEWOOD CLIFFS,
NEW JERSEY, 07632, U.S.A**

Prepared by

**UL VERIFICATION SERVICES
47173 BENICIA STREET
FREMONT, CA 94538, U.S.A.
TEL: (510) 771-1000
FAX: (510) 661-0888**



NVLAP LAB CODE 200065-0

Revision History

Rev.	Issue Date	Revisions	Revised By
--	05/26/15	Initial Issue	--
A	05/28/15	Updated report remove EGPRS data	D. Corona

TABLE OF CONTENTS

1.	ATTESTATION OF TEST RESULTS	5
2.	TEST METHODOLOGY	6
3.	FACILITIES AND ACCREDITATION	6
4.	CALIBRATION AND UNCERTAINTY	6
4.1.	<i>MEASURING INSTRUMENT CALIBRATION</i>	<i>6</i>
4.2.	<i>SAMPLE CALCULATION</i>	<i>6</i>
4.3.	<i>MEASUREMENT UNCERTAINTY</i>	<i>7</i>
5.	EQUIPMENT UNDER TEST	8
5.1.	<i>DESCRIPTION OF EUT</i>	<i>8</i>
5.2.	<i>MAXIMUM OUTPUT POWER.....</i>	<i>8</i>
5.3.	<i>DESCRIPTION OF AVAILABLE ANTENNAS</i>	<i>9</i>
5.4.	<i>DESCRIPTION OF TEST SETUP.....</i>	<i>10</i>
6.	TEST AND MEASUREMENT EQUIPMENT	13
7.	SUMMARY TABLE	14
8.	RF POWER OUTPUT VERIFICATION.....	15
8.1.	<i>GSM/GPRS/EDGE</i>	<i>15</i>
8.1.1.	<i>GSM OUTPUT POWER RESULT</i>	<i>16</i>
8.2.	<i>UMTS REL 99.....</i>	<i>17</i>
8.2.1.	<i>UMTS REL 99 OUTPUT POWER RESULT</i>	<i>18</i>
8.3.	<i>UMTS HSDPA</i>	<i>19</i>
8.3.1.	<i>UMTS HSDPA OUTPUT POWER RESULT.....</i>	<i>20</i>
8.4.	<i>UMTS HSUPA</i>	<i>21</i>
8.4.1.	<i>UMTS HSUPA OUTPUT POWER RESULT.....</i>	<i>22</i>
9.	PEAK TO AVERAGE RATIO	23
9.1.	<i>CONDUCTED PEAK TO AVERAGE RESULT.....</i>	<i>23</i>
10.	LIMITS AND CONDUCTED RESULTS.....	26
10.1.	<i>OCCUPIED BANDWIDTH.....</i>	<i>26</i>
10.1.1.	<i>OCCUPIED BANDWIDTH RESULTS.....</i>	<i>27</i>
10.1.1.	<i>OCCUPIED BANDWIDTH PLOTS</i>	<i>28</i>
10.2.	<i>BAND EDGE EMISSIONS</i>	<i>30</i>
10.2.1.	<i>BAND EDGE PLOTS</i>	<i>31</i>
10.3.	<i>OUT OF BAND EMISSIONS</i>	<i>34</i>

10.3.1. OUT OF BAND EMISSIONS RESULT35
10.3.2. OUT OF BAND EMISSIONS PLOTS.....36
10.4. FREQUENCY STABILITY38
10.4.1. FREQUENCY STABILITY RESULTS.....39
11. RADIATED TEST RESULTS41
11.1. RADIATED POWER (ERP & EIRP).....41
11.1.1. ERP/EIRP Results.....42
11.1.2. ERP/EIRP PLOTS.....43
11.2. FIELD STRENGTH OF SPURIOUS RADIATION51
11.2.1. SPURIOUS RADIATION PLOTS.....52
12. SETUP PHOTOS58

1. ATTESTATION OF TEST RESULTS

COMPANY NAME: LG ELECTRONICS MOBILECOMM U.S.A., INC
EUT DESCRIPTION: GSM/WCDMA PHONE
MODEL: LG329G
SERIAL NUMBER: 504CQDG839306 (RADIATED AND CONDUCTED)
DATE TESTED: MAY 11-26, 2015

APPLICABLE STANDARDS	
STANDARD	TEST RESULTS
FCC PART 22H and 24E	PASS

UL Verification Services Inc. tested the above equipment in accordance with the requirements set forth in the above standards. All indications of Pass/Fail in this report are opinions expressed by UL Verification Services Inc. based on interpretations and/or observations of test results. Measurement Uncertainties were not taken into account and are published for informational purposes only. The test results show that the equipment tested is capable of demonstrating compliance with the requirements as documented in this report.

Note: The results documented in this report apply only to the tested sample, under the conditions and modes of operation as described herein. This document may not be altered or revised in any way unless done so by UL Verification Services Inc. and all revisions are duly noted in the revisions section. Any alteration of this document not carried out by UL Verification Services Inc. will constitute fraud and shall nullify the document. This report must not be used by the client to claim product certification, approval, or endorsement by NVLAP, NIST, any agency of the Federal Government, or any agency of any government.

Approved & Released For
UL Verification Services Inc. By:



DAN CORONIA
CONSUMER TECHNOLOGY DIVISION
WiSE PROJECT LEAD
UL VERIFICATION SERVICES INC

Tested By:



STEVEN TRAN
CONSUMER TECHNOLOGY DIVISION
WiSE LAB ENGINEER
UL VERIFICATION SERVICES INC

2. TEST METHODOLOGY

The tests documented in this report were performed in accordance with TIA-603-C, FCC CFR 47 Part 22 and FCC CFR Part 24.

3. FACILITIES AND ACCREDITATION

The test sites and measurement facilities used to collect data are located at 47173 and 47266 Benicia Street, Fremont, California, USA. Line conducted emissions are measured only at the 47173 address. The following table identifies which facilities were utilized for radiated emission measurements documented in this report. Specific facilities are also identified in the test results sections.

47173 Benicia Street	47266 Benicia Street
<input checked="" type="checkbox"/> Chamber A(IC: 2324B-1)	<input type="checkbox"/> Chamber D(IC: 2324B-4)
<input type="checkbox"/> Chamber B(IC: 2324B-2)	<input type="checkbox"/> Chamber E(IC: 2324B-5)
<input checked="" type="checkbox"/> Chamber C(IC: 2324B-3)	<input type="checkbox"/> Chamber F(IC: 2324B-6)
	<input type="checkbox"/> Chamber G(IC: 2324B-7)
	<input type="checkbox"/> Chamber H(IC: 2324B-8)

UL Verification Services Inc. is accredited by NVLAP, Laboratory Code 200065-0. The full scope of accreditation can be viewed at <http://ts.nist.gov/standards/scopes/2000650.htm>.

4. CALIBRATION AND UNCERTAINTY

4.1. MEASURING INSTRUMENT CALIBRATION

The measuring equipment utilized to perform the tests documented in this report has been calibrated in accordance with the manufacturer's recommendations, and is traceable to recognized national standards

4.2. SAMPLE CALCULATION

Where relevant, the following sample calculation is provided:

EIRP = PSA reading with EUT worst orientation (dBm) + Path loss (dB) – cable loss(between the SG and substitution antenna) + Substitution Antenna Factor (dBi)

ERP = PSA reading with EUT worst orientation (dBm) + Path loss (dB) – cable loss(between the SG and substitution antenna)

(Path loss = Signal generator output – PSA reading with substitution antenna)

4.3. MEASUREMENT UNCERTAINTY

Where relevant, the following measurement uncertainty levels have been estimated for tests performed on the apparatus:

PARAMETER	UNCERTAINTY
Conducted Disturbance, 0.15 to 30 MHz	3.52 dB
Radiated Disturbance, 30 to 1000 MHz	4.94 dB
Radiated Disturbance, 1GHz to 40GHz	4.94 dB

Uncertainty figures are valid to a confidence level of 95%.

5. EQUIPMENT UNDER TEST

5.1. DESCRIPTION OF EUT

The EUT is a GSM/WCDMA PHONE.

5.2. MAXIMUM OUTPUT POWER

The transmitter has a maximum peak conducted and radiated ERP / EIRP output powers as follows:

FCC Part 22/24						
Band	Frequency Range(MHz)	Modulation	Conducted		Radiated	
			AVG(dBm)	AVG(mW)	AVG(dBm)	AVG(mW)
GSM850	824~849	GMSK	32.60	1819.70		
	824~849	GPRS	32.50	1778.28	30.04	1009.49
GSM1900	1850~1910	GMSK	30.60	1148.15		
	1850~1910	GPRS	30.60	1148.15	29.87	970.51
Band 5	824~849	REL99	22.80	190.55	21.47	140.28
	824~849	HSDPA	22.60	181.97	21.12	129.42
	824~849	HSUPA	22.90	194.98		
Band 2	1850~1910	REL99	22.50	177.83	21.85	153.11
	1850~1910	HSDPA	21.90	154.88	21.76	149.97
	1850~1910	HSUPA	22.40	173.78		

5.3. DESCRIPTION OF AVAILABLE ANTENNAS

The radio utilizes a PIFA antenna for the [List the bands supported] with a maximum peak gain as follow:

Frequency (MHz)	Peak Gain (dBi)
GSM850, BAND 5, 824~849MHz	-1.7
GSM1900, BAND 2, 1850~1910MHz	1.1

5.4. DESCRIPTION OF TEST SETUP

SUPPORT EQUIPMENT

Support Equipment List				
Description	Manufacturer	Model	Serial Number	FCC ID
AC Adapter	LG	STA-U34WRI	RE510001344	N/A
Headset	LG	N/A	N/A	N/A

I/O CABLES (CONDUCTED SETUP)

I/O Cable List						
Cable No	Port	# of identical ports	Connector Type	Cable Type	Cable Length (m)	Remarks
1	RF Out	1	Spectrum Analyzer	Shielded	None	NA
2	Antenna Port	1	EUT	Shielded	0.1m	NA
3	RF In/Out	1	Communication Test Set	Shielded	1m	NA

I/O CABLES (RADIATED SETUP)

I/O CABLE LIST						
Cable No.	Port	# of Identical Ports	Connector Type	Cable Type	Cable Length	Remarks
1	USB	1	AC Adapter	Un-shielded	1.2m	NA
2	Jack	1	Headset	Shielded	1m	NA
3	RF In/out	1	Communication Test Set	Un-shielded	2m	NA

TEST SETUP

The EUT is continuously communicated to the call box during the tests.

SETUP DIAGRAM FOR TESTS (CONDUCTED TEST SETUP)

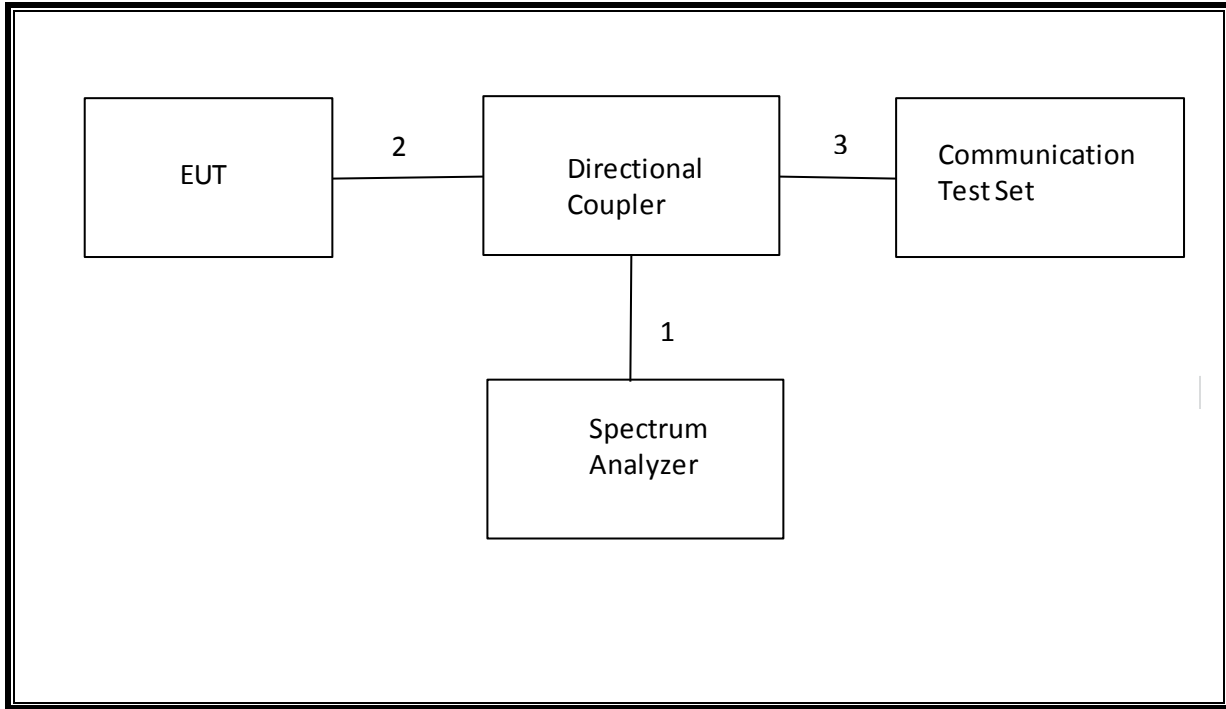

SETUP DIAGRAM FOR TESTS (RADIATED TEST SETUP)

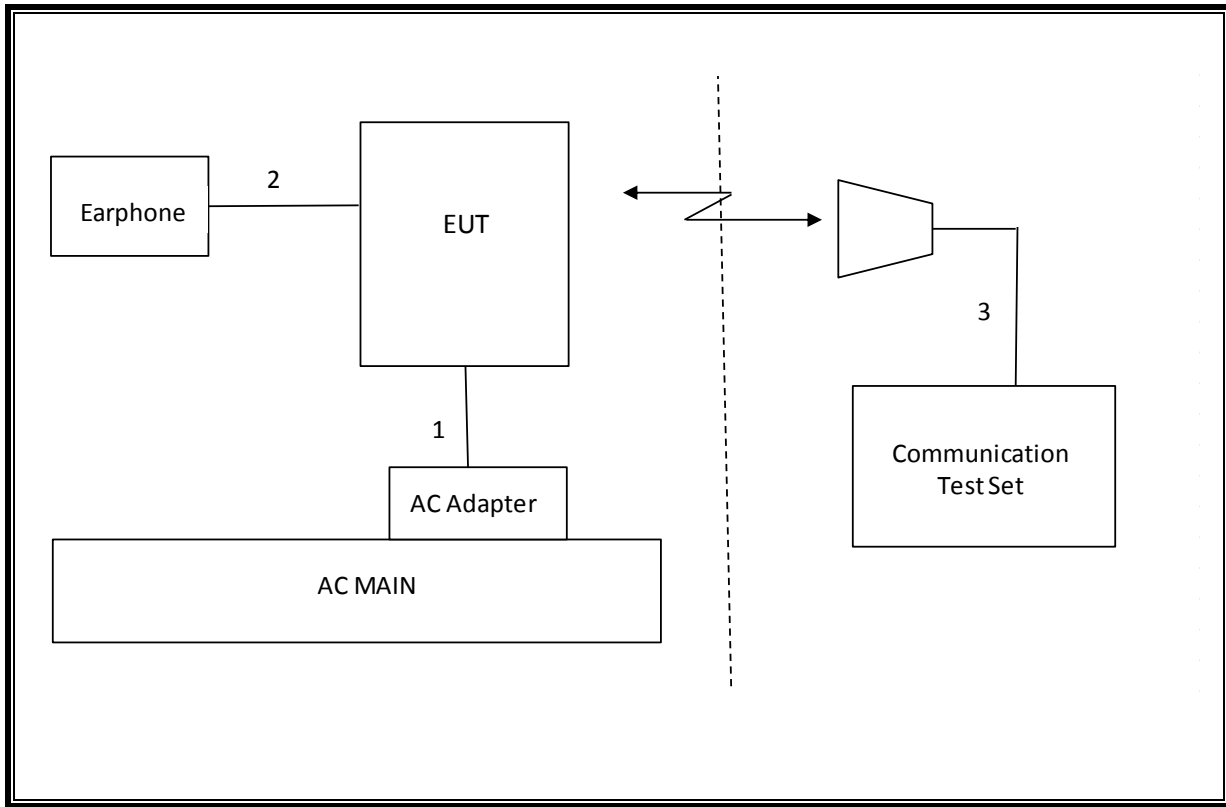

6. TEST AND MEASUREMENT EQUIPMENT

The following test and measurement equipment was utilized for the tests documented in this report:

TEST EQUIPMENT LIST				
Description	Manufacturer	Model	Tnumber	Cal Due
Spectrum Analyzer, 44 GHz	Agilent / HP	E4446A	123	10/28/15
Antenna, Bilog, 2 GHz	Sunol Sciences	JB1	243	12/08/15
Antenna, Horn, 18 GHz	EMCO	3115	60	01/15/16
Highpass Filter, 2.7 GHz	Micro-Tronics	HPM13194	151	CNR
Highpass Filter, 1.5 GHz	Micro-Tronics	HPM13193	153	CNR
Temperature / Humidity Chamber	Thermotron	SE 600-10-10	80	11/01/15
Communications Test Set	R&S	CMW500	159	07/02/15
DC power supply, 8 V @ 3 A or 15 V	Agilent / HP	E3610A	502	CNR
Vector signal generator, 6 GHz	Agilent / HP	E4438C	933	06/18/15
Antenna, Active Loop 9kHz to 30MHz	ETS	6502	757	10/14/15
Directional Coupler	RF-Lambda	RFDC5M06G15	None	CNR
Antenna, Horn, 26.5 GHz	ARA	MWH-1826/B	89	12/17/15

Test Software List			
Description	Manufacturer	Model	Version
Radiated Software	UL	UL EMC	Version 9.5, 07/22/14
Conducted Software	UL	UL EMC	Version 9.5, 05/17/14
CLT Software	UL	UL RF	Version 1.0, 02/02/15
Antenna Port Software	UL	UL RF	Version 2.1.1.1, 1/20/15

7. SUMMARY TABLE

FCC Part Section	RSS Section(s)	Test Description	Test Limit	Test Condition	Test Result	Note
2.1049	N/A	Occupied Band width (99%)	N/A	Conducted	Pass	4.177 MHz
22.917(a) 24.238(a) 27.53(g) 90.691	RSS-132(4.5.1) RSS-133(6.5.1) RSS-139(6.5.1)	Band Edge / Conducted Spurious Emission	-13dBm		Pass	-16.98 dBm
22.355 24.235 27.54 90.213	RSS-132(4.3) RSS-133(6.3) RSS-139(6.3) RSS-199(4.3)	Frequency Stability	2.5PPM		Pass	0.021 PPM
22.913(a)(2)	RSS-132(4.4)	Effective Radiated Power	38 dBm	Radiated	Pass	30.04 dBm
24.232(c) 27.50(h)(2)	RSS-133(6.4) RSS-199(4.4)	Equivalent Isotropic Radiated Power	33dBm		Pass	29.87 dBm
22.917(a) 24.238(a) 27.53(g)	RSS-132(4.5.1) RSS-133(6.5.1) RSS-139(6.5.1)	Radiated Spurious Emission	-13dBm		Pass	-39.3 dBm

8. RF POWER OUTPUT VERIFICATION

8.1. GSM/GPRS/EDGE

Function: Menu select > GSM Mobile Station > GSM 850/900/1800/1900
Press Connection control to choose the different menus
Press RESET > choose all to reset all settings
Connection Press Signal Off to turn off the signal and change settings
Network Support > GSM+GPRS or GSM+EGPRS
Main Service > Packet Data
Service selection > Test Mode A – Auto Slot Config. off
MS Signal Press Slot Config bottom on the right twice to select and change the number of time slots and power setting
 > Slot configuration > Uplink/Gamma
 > 33 dBm for GPRS 850/900
 > 30 dBm for GPRS1800/1900
BS Signal Enter the same channel number for TCH channel (test channel) and BCCH channel
Frequency Offset > + 0 Hz
Mode > BCCH and TCH
BCCH Level > -85 dBm (May need to adjust if link is not stable)
BCCH Channel > choose desire test channel [Enter the same channel number for TCH channel (test channel) and BCCH channel]
Channel Type > Off
P0> 4 dB
Slot Config > Unchanged (if already set under MS Signal)
TCH > choose desired test channel
Hopping > Off
Main Timeslot > 3 (Default)
Network Coding Scheme > CS4 (GPRS) and MCS5 ~ MCS9 (EGPRS)
 Bit Stream > 2E9-1PSR Bit Pattern
AF/RF Enter appropriate offsets for Ext. Att. Output and Ext. Att. Input
Connection Press Signal On to turn on the signal and change settings

8.1.1. GSM OUTPUT POWER RESULT

Mode	Coding Scheme	Time Slots	Ch No.	Freq. (MHz)	Burst Pwr (dBm)
GSM (Voice)	CS1	1	128	824.2	32.5
			190	836.6	32.6
			251	848.8	32.6
GPRS (GMSK)	CS1	1	128	824.2	32.4
			190	836.6	32.5
			251	848.8	32.5
		2	128	824.2	30.5
			190	836.6	30.6
			251	848.8	30.6

Mode	Coding Scheme	Time Slots	Ch No.	Freq. (MHz)	Burst Pwr (dBm)
GSM (Voice)	CS1	1	512	1850.2	30.6
			661	1880.0	30.6
			810	1909.8	30.5
GPRS (GMSK)	CS1	1	512	1850.2	30.6
			661	1880.0	30.6
			810	1909.8	30.5
		2	512	1850.2	28.6
			661	1880.0	28.6
			810	1909.8	28.6

8.2. UMTS REL 99

TEST PROCEDURE

The following summary of these settings are illustrated below:

	Mode	Rel99
	Subtest	-
WCDMA General Settings	Loopback Mode	Test Mode 1
	Rel99 RMC	12.2kbps RMC
	HSDPA FRC	Not Applicable
	HSUPA Test	Not Applicable
	Power Control Algorithm	Algorithm2
	β_c	Not Applicable
	β_d	Not Applicable
	β_{ec}	Not Applicable
	β_c/β_d	8/15
	β_{hs}	Not Applicable
	β_{ed}	Not Applicable

8.2.1. UMTS REL 99 OUTPUT POWER RESULT

Band	Mode	UL Ch No.	Freq. (MHz)	MPR	Avg Pwr (dBm)
W-CDMA Band V	Rel 99 (RMC, 12.2 kbps)	4132	826.4	0	22.8
		4183	836.6	0	22.7
		4233	846.6	0	22.7

Band	Mode	UL Ch No.	Freq. (MHz)	MPR	Avg Pwr (dBm)
W-CDMA Band II	Rel 99 (RMC, 12.2 kbps)	9262	1852.4	0	22.5
		9400	1880.0	0	22.3
		9538	1907.6	0	22.3

8.3. UMTS HSDPA

The following 4 Sub-tests were completed according to Release 5 procedures in section 5.2 of 3GPP TS34.121. A summary of these settings are illustrated below:

	Mode	Rel5 HSDPA			
	Subtest	1	2	3	4
WCDMA General Settings	Loopback Mode	Test Mode 1			
	Rel99 RMC	12.2kbps RMC			
	HSDPA FRC	H-Set1			
	Power Control Algorithm	Algorithm 2			
	β_c	2/15	12/15	15/15	15/15
	β_d	15/15	15/15	8/15	4/15
	Bd (SF)	64			
	β_c/β_d	2/15	12/15	15/8	15/4
	β_{hs}	4/15	24/15	30/15	30/15
	MPR (dB)	0	0	0.5	0.5
HSDPA Specific Settings	D_{ACK}	8			
	D_{NAK}	8			
	DCQI	8			
	Ack-Nack repetition factor	3			
	CQI Feedback (Table 5.2B.4)	4ms			
	CQI Repetition Factor (Table 5.2B.4)	2			
	$A_{hs} = \beta_{hs}/\beta_c$	30/15			

8.3.1. UMTS HSDPA OUTPUT POWER RESULT

Band	Mode	UL Ch No.	Freq. (MHz)	MPR	Avg Pwr (dBm)
W-CDMA Band V	Subtest 1	4132	826.4	0	22.6
		4183	836.6	0	22.5
		4233	846.6	0	22.5
	Subtest 2	4132	826.4	0	22.6
		4183	836.6	0	22.4
		4233	846.6	0	22.5
	Subtest 3	4132	826.4	0.5	22.6
		4183	836.6	0.5	22.5
		4233	846.6	0.5	22.4
	Subtest 4	4132	826.4	0.5	22.6
		4183	836.6	0.5	22.5
		4233	846.6	0.5	22.4

Band	Mode	UL Ch No.	Freq. (MHz)	MPR	Avg Pwr (dBm)
W-CDMA Band II	Subtest 1	9262	1852.4	0	21.7
		9400	1880.0	0	21.8
		9538	1907.6	0	21.6
	Subtest 2	9262	1852.4	0	21.7
		9400	1880.0	0	21.7
		9538	1907.6	0	21.9
	Subtest 3	9262	1852.4	0.5	21.8
		9400	1880.0	0.5	21.7
		9538	1907.6	0.5	21.7
	Subtest 4	9262	1852.4	0.5	21.7
		9400	1880.0	0.5	21.6
		9538	1907.6	0.5	21.8

8.4. UMTS HSUPA

TEST PROCEDURE

The following summary of these settings are illustrated below: (ETSI TS 134.121-1 Table C.11.1)

	Mode	Rel6 HSUPA	Rel6 HSUPA	Rel6 HSUPA	Rel6 HSUPA	Rel6 HSUPA
	Subtest	1	2	3	4	5
WCDMA General Settings	Loopback Mode	Test Mode 1				
	P-CPICH (dB)	-10				
	P-CCPCH (dB)	-12				
	SCH (dB)	-12				
	PICH(dB)	-15				
	DPCH (dB)	-9				
	HS-SCCH_1 (dB)	-8				
	HS-PDSCH (dB)	-3				
	Rel99 RMC	12.2kbps RMC				
	HSDPA FRC	H-Set1				
	HSUPA Test	HSUPA Loopback				
	Power Control Algorithm	Algorithm2				
	Bc	11/15	6/15	15/15	2/15	15/15
	Bd	15/15	15/15	9/15	15/15	15/15
	Bec	209/225	12/15	30/15	2/15	5/15
	β_c/β_d	11/15	6/15	15/9	2/15	15/15
	Bhs	22/15	12/15	30/15	4/15	30/15
β_{ed} (note1)	1309/225	94/75	47/15 47/15	56/75	134/15	
MPR	0	2	1	2	0	
HSDPA Specific Settings	DACK	8				
	DNAK	8				
	DCQI	8				
	Ack-Nack repetition factor	3				
	CQI Feedback (Table 5.2B.4)	4ms				
	CQI Repetition Factor (Table 5.2B.4)	2				
	$A_{hs} = \beta_{hs}/\beta_c$	30/15				
HSUPA Specific Settings	D E-DPCCH	6	8	8	5	7
	DHARQ	0	0	0	0	0
	AG Index	20	12	15	17	21
	Reference E-TFCIs	5	5	2	5	5
	ETFCI (from 34.121 Table C.11.1.3)	75	67	92	71	81
	Associated Max UL Data Rate kbps	242.1	174.9	482.8	205.8	308.9
	Reference E_TFCIs	E-TFCI 11 E-TFCI PO 4 E-TFCI 67 E-TFCI PO 18 E-TFCI 71 E-TFCI PO 23 E-TFCI 75 E-TFCI PO 26 E-TFCI 81 E-TFCI PO 27		E-TFCI 11 E-TFCI PO 4 E-TFCI 92 E-TFCI PO 18		E-TFCI 11 E-TFCI PO 4 E-TFCI 67 E-TFCI PO 18 E-TFCI 71 E-TFCI PO 23 E-TFCI 75 E-TFCI PO 26 E-TFCI 81 E-TFCI PO 27

Note1: β_{ed} cannot be set directly, it is set by Absolute Grant Value.

8.4.1. UMTS HSUPA OUTPUT POWER RESULT

Band	Mode	UL Ch No.	Freq. (MHz)	MPR	Avg Pwr (dBm)
W-CDMA Band V	Subtest 1	4132	826.4	0	22.9
		4183	836.6	0	22.8
		4233	846.6	0	22.8
	Subtest 2	4132	826.4	2	22.9
		4183	836.6	2	22.9
		4233	846.6	2	22.8
	Subtest 3	4132	826.4	1	21.8
		4183	836.6	1	22.0
		4233	846.6	1	21.9
	Subtest 4	4132	826.4	2	22.9
		4183	836.6	2	22.8
		4233	846.6	2	22.9
	Subtest 5	4132	826.4	0	21.2
		4183	836.6	0	21.2
		4233	846.6	0	21.2

Band	Mode	UL Ch No.	Freq. (MHz)	MPR	Avg Pwr (dBm)
W-CDMA Band II	Subtest 1	9262	1852.4	0	22.4
		9400	1880.0	0	22.3
		9538	1907.6	0	22.2
	Subtest 2	9262	1852.4	2	22.3
		9400	1880.0	2	22.3
		9538	1907.6	2	22.2
	Subtest 3	9262	1852.4	1	22.3
		9400	1880.0	1	22.3
		9538	1907.6	1	22.3
	Subtest 4	9262	1852.4	2	22.4
		9400	1880.0	2	22.3
		9538	1907.6	2	22.3
	Subtest 5	9262	1852.4	0	20.7
		9400	1880.0	0	20.7
		9538	1907.6	0	20.7

9. PEAK TO AVERAGE RATIO

TEST PROCEDURE

Per KDB 971168 D01 Power Meas License Digital Systems v02r02

TEST SPEC

In addition, when the transmitter power is measured in terms of average value, the peak-to-average ratio of the power shall not exceed 13 dB.

9.1. CONDUCTED PEAK TO AVERAGE RESULT

MODES TESTED

GSM, WCDMA

RESULTS

GSM

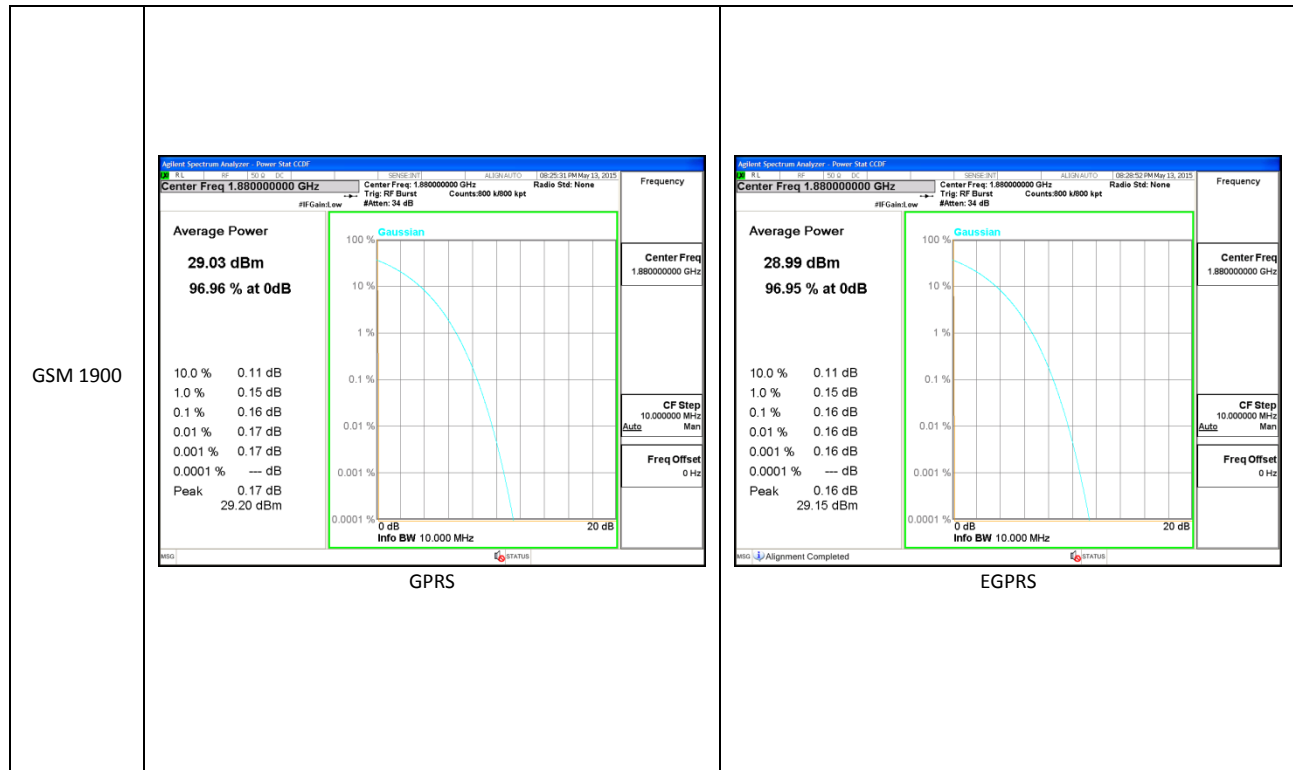

WCDMA

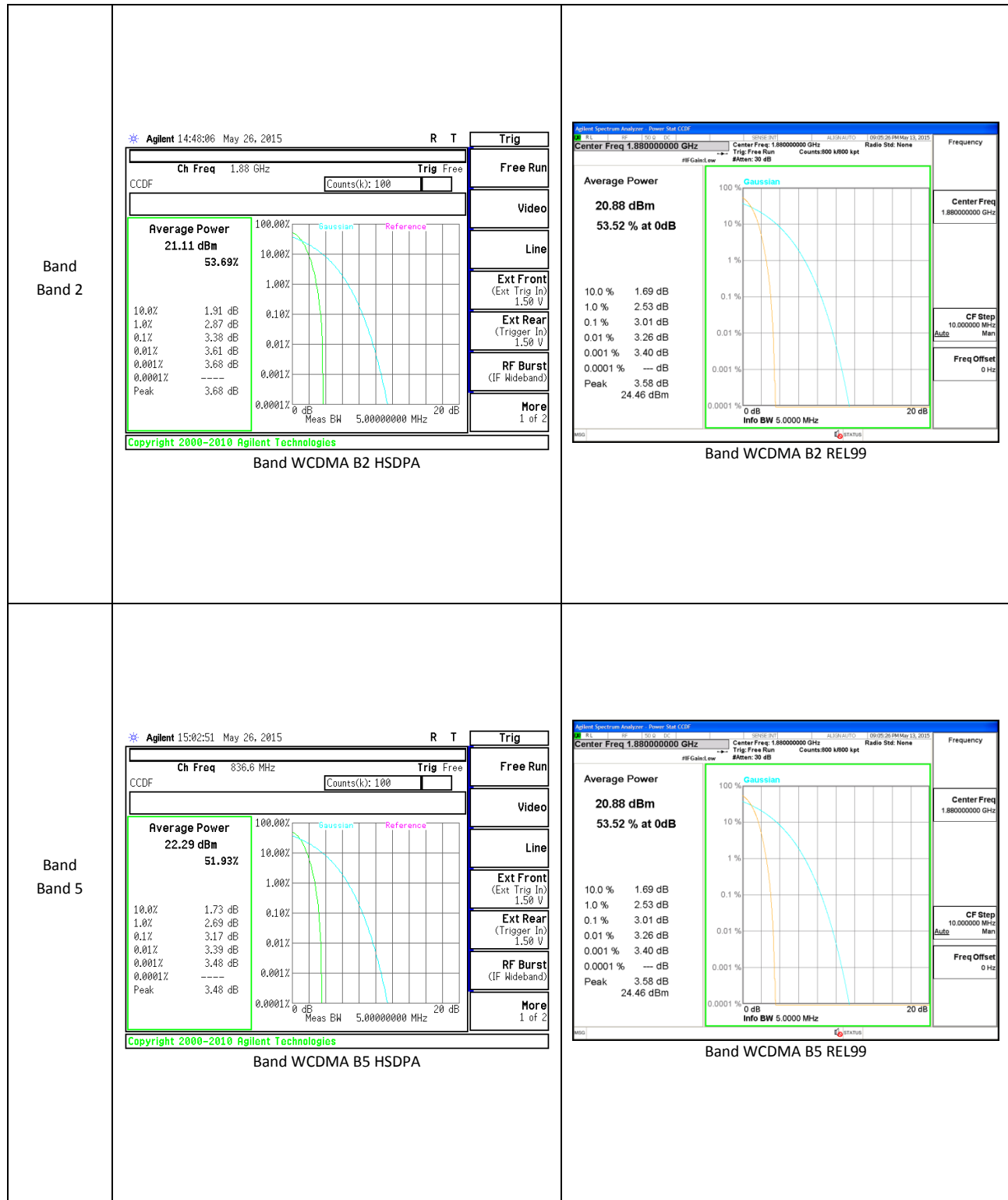

10. LIMITS AND CONDUCTED RESULTS

10.1. OCCUPIED BANDWIDTH

RULE PART(S)

FCC: §2.1049

LIMITS

For reporting purposes only

TEST PROCEDURE

The transmitter output was connected to a calibrated coaxial cable and coupler, the other end of which was connected to a spectrum analyzer. The occupied bandwidth was measured with the spectrum analyzer at the low, middle and high channel in each band. The -26dB bandwidth was also measured and recorded.

(KDB 971168 D01 Power Meas License Digital Systems v02r02)

MODES TESTED

GSM, WCDMA

RESULTS

10.1.1. OCCUPIED BANDWIDTH RESULTS

Band	Mode	Channel	f (MHz)	99% BW (KHz)	-26dB BW (KHz)
GSM850	GPRS	128	824.2	249.3	311.9
		190	836.6	244.6	312.9
		251	848.8	247.2	313.7
GSM1900	GPRS	512	1850.2	245.60	317.30
		661	1880.0	244.10	316.30
		810	1909.8	246.30	318.10

Band	Mode	Channel	f (MHz)	99% BW (MHz)	-26dB BW (MHz)
Band 5	REL99	4132	826.4	4.116	4.636
		4183	836.6	4.132	4.637
		4233	846.6	4.145	4.638
	HSDPA	4132	826.4	4.174	4.628
		4183	836.6	4.177	4.635
		4233	846.6	4.162	4.662
Band 2	REL99	9262	1852.4	4.169	4.647
		9400	1880.0	4.155	4.646
		9538	1907.6	4.171	4.653
	HSDPA	9262	1852.4	4.164	4.614
		9400	1880.0	4.164	4.632
		9538	1907.6	4.164	4.611

10.1.1. OCCUPIED BANDWIDTH PLOTS

GSM

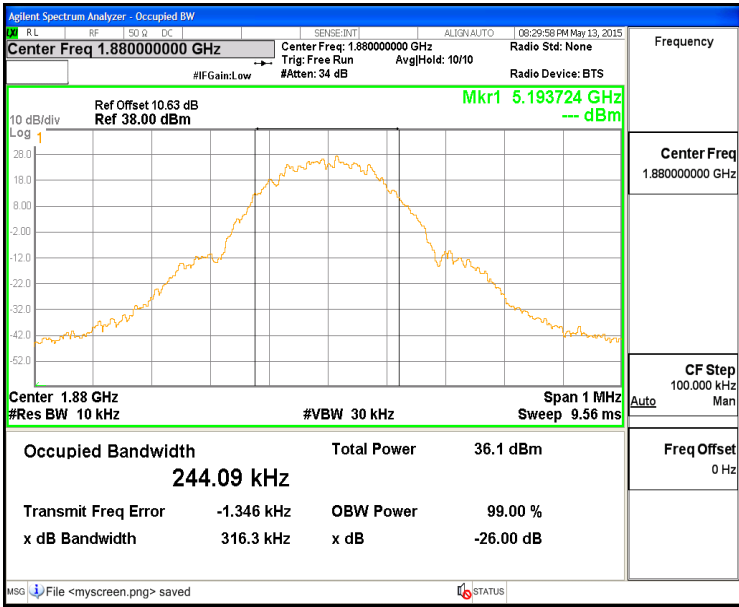
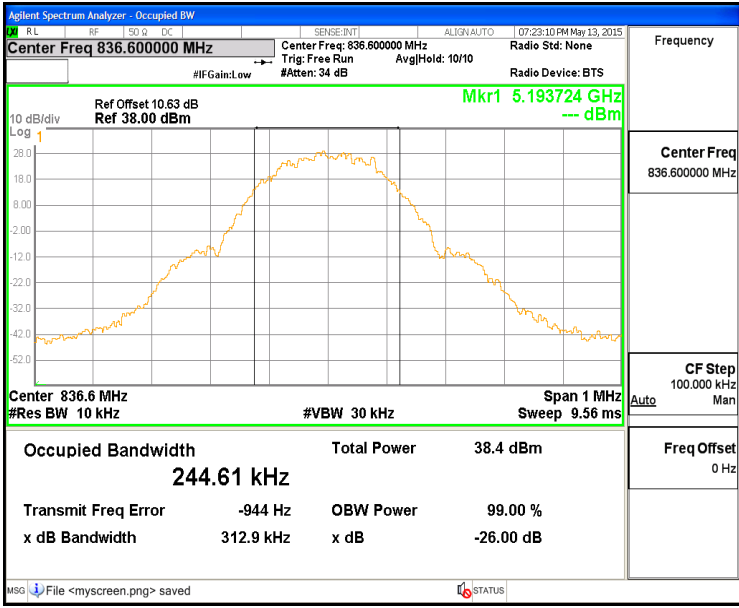
<p>Band GSM 1900</p>	 <p style="text-align: center;">Band GSM1900 GPRS OBW Mid channel</p>
<p>Band GSM 850</p>	 <p style="text-align: center;">Band GSM850 GPRS OBW Mid channel</p>

WCDMA

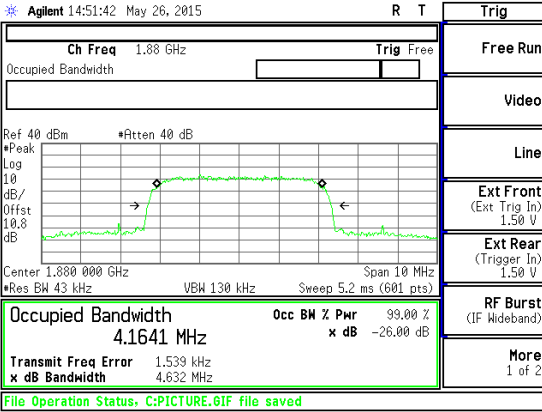
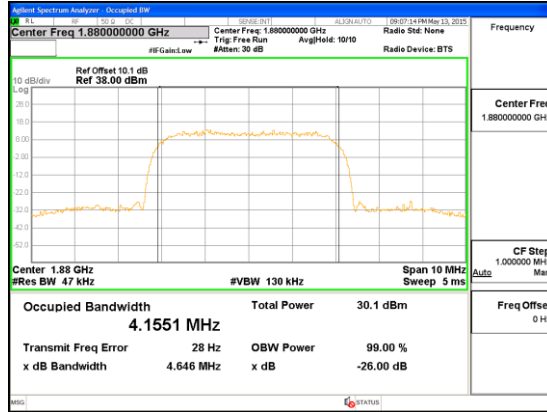
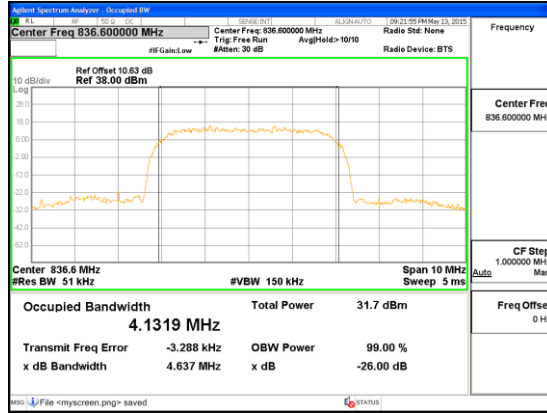
<p>Band Band 2</p>	 <p>Agilent 14:51:42 May 26, 2015</p> <p>Ch Freq 1.88 GHz</p> <p>Occupied Bandwidth</p> <p>Ref 40 dBm *Atten 40 dB</p> <p>Occupied Bandwidth 4.1641 MHz</p> <p>Transmit Freq Error 1.539 kHz</p> <p>x dB Bandwidth 4.632 MHz</p> <p>File Operation Status, C:PICTURE.GIF file saved</p> <p>Band WCDMA B2 HSDPA OBW</p>	 <p>Agilent Spectrum Analyzer - Occupied BW</p> <p>Center Freq 1.88000000 GHz</p> <p>Occupied Bandwidth 4.1551 MHz</p> <p>Total Power 30.1 dBm</p> <p>Transmit Freq Error 28 Hz</p> <p>x dB Bandwidth 4.646 MHz</p> <p>OBW Power 99.00 %</p> <p>x dB -26.00 dB</p> <p>Band WCDMA B2 REL99 OBW</p>
<p>Band Band 5</p>	 <p>Agilent 15:06:32 May 26, 2015</p> <p>Ch Freq 836.6 MHz</p> <p>Occupied Bandwidth</p> <p>Ref 40 dBm *Atten 40 dB</p> <p>Occupied Bandwidth 4.1772 MHz</p> <p>Transmit Freq Error 1.445 kHz</p> <p>x dB Bandwidth 4.635 MHz</p> <p>File Operation Status, C:PICTURE.GIF file saved</p> <p>Band WCDMA B5 HSDPA OBW</p>	 <p>Agilent Spectrum Analyzer - Occupied BW</p> <p>Center Freq 836.600000 MHz</p> <p>Occupied Bandwidth 4.1319 MHz</p> <p>Total Power 31.7 dBm</p> <p>Transmit Freq Error -3.288 kHz</p> <p>x dB Bandwidth 4.637 MHz</p> <p>OBW Power 99.00 %</p> <p>x dB -26.00 dB</p> <p>Band WCDMA B5 REL99 OBW</p>

10.2. BAND EDGE EMISSIONS

RULE PART(S)

FCC: §22.359 and §24.238

LIMITS

The power of any emission outside of the authorized operating frequency ranges must be attenuated below the transmitting power (P) by a factor of at least $43 + 10 \log (P)$ dB.

TEST PROCEDURE

Per KDB 971168 D01 Power Meas License Digital Systems v02r02

The transmitter output was connected to an Agilent 8960 or a CMW500 Test Set and configured to operate at maximum power. The band edge emissions were measured at the required operating frequencies in each band on the Spectrum Analyzer.

MODES TESTED

GSM, WCDMA

RESULTS

10.2.1. BAND EDGE PLOTS

GSM

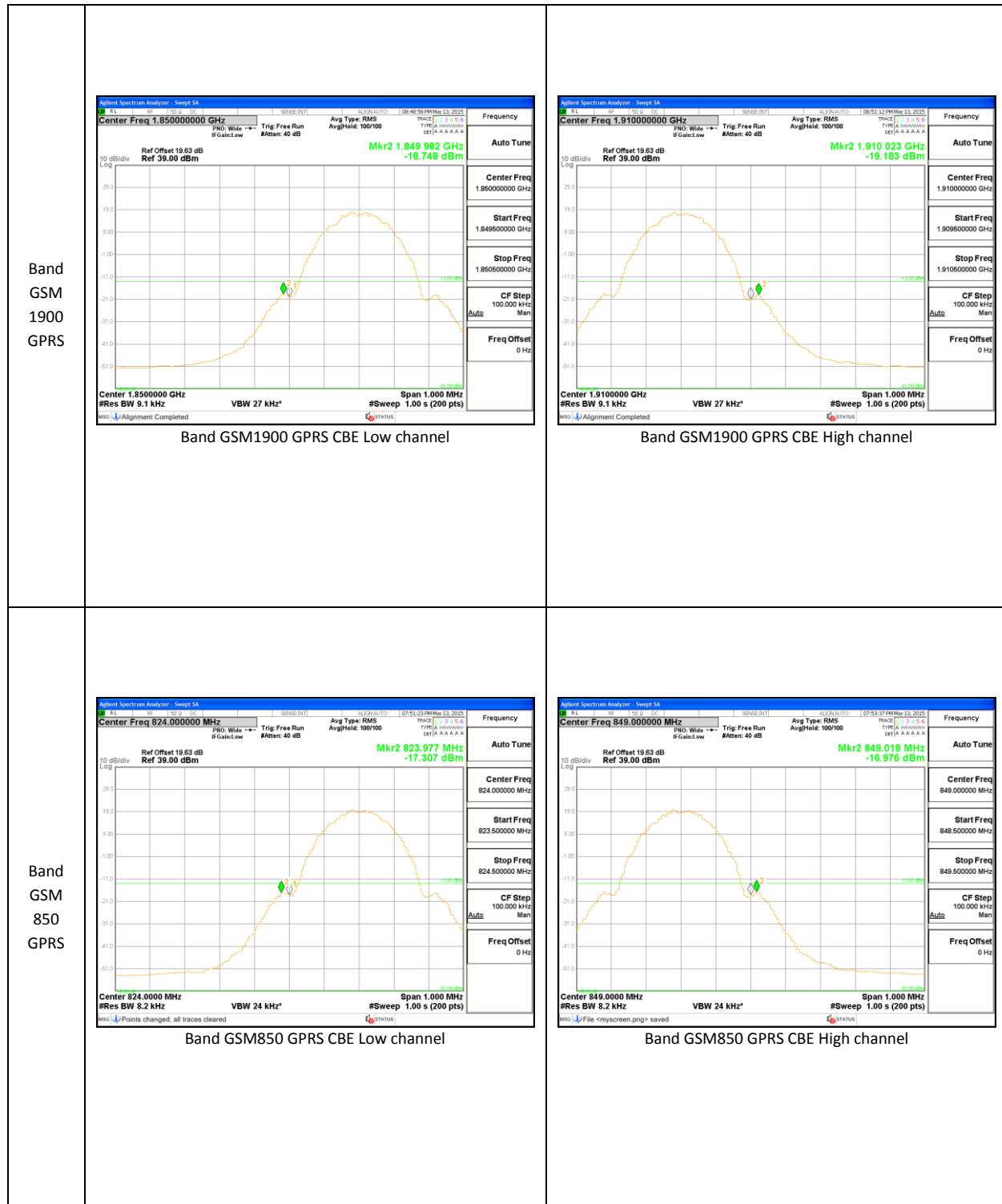

WCDMA

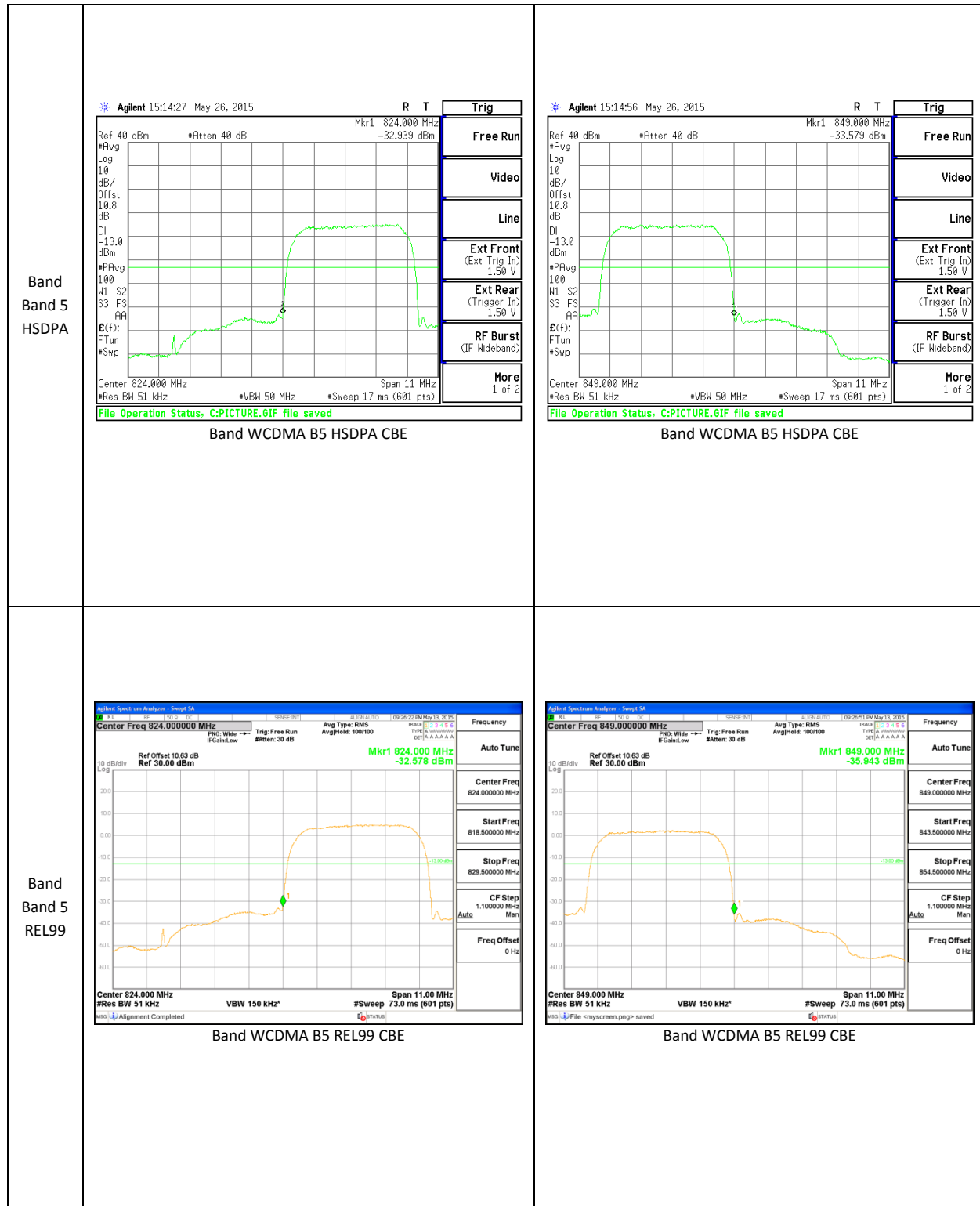

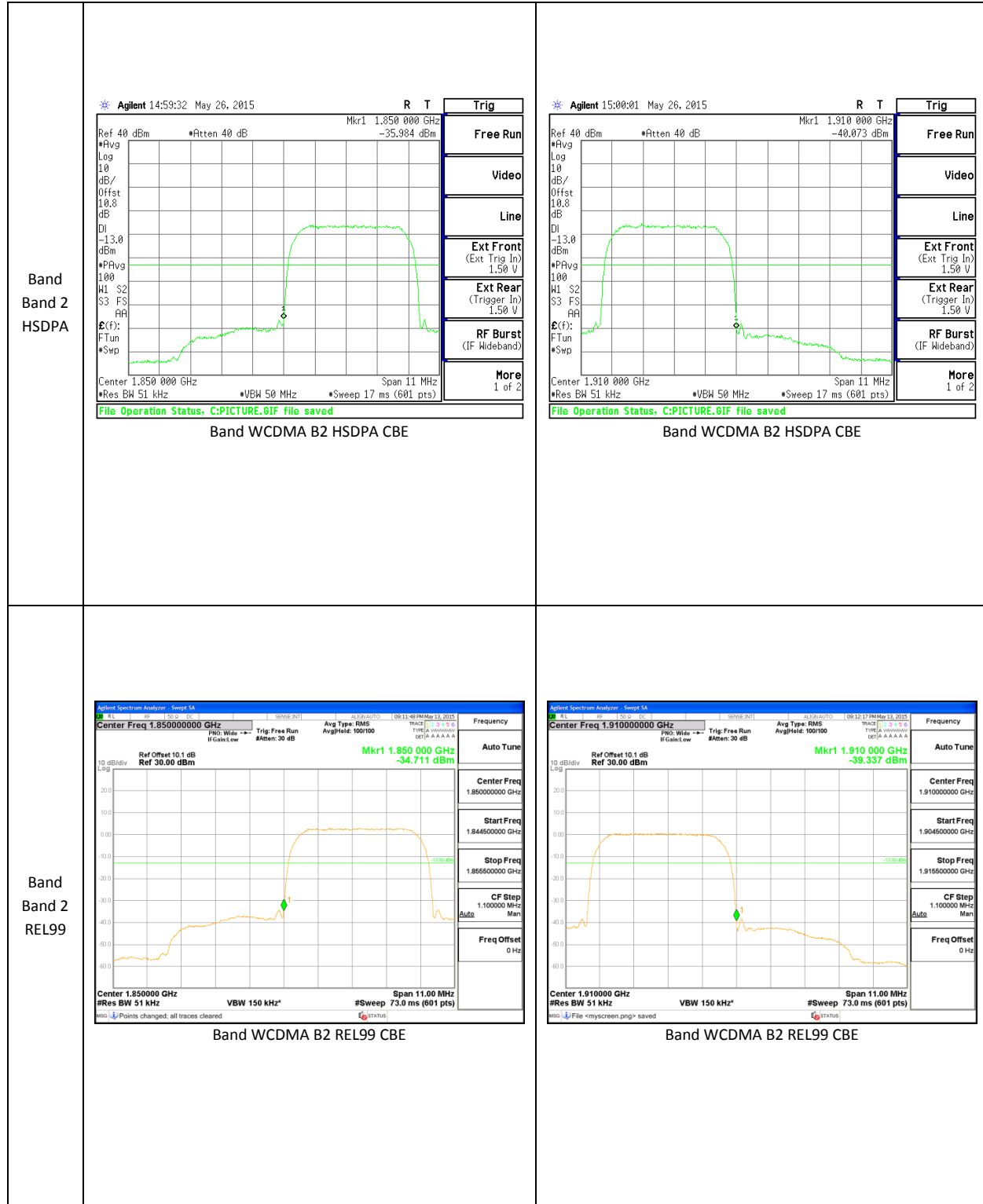

10.3. OUT OF BAND EMISSIONS

RULE PART(S)

FCC: §2.1051, §22.901, §22.917, §24.238

LIMITS

The power of any emission outside of the authorized operating frequency ranges must be attenuated below the transmitting power (P) by a factor of at least $43 + 10 \log (P)$ dB.

TEST PROCEDURE

Per KDB 971168 D01 Power Meas License Digital Systems v02r02

The RF output of the transmitter was connected to a spectrum analyzer through a calibrated coaxial cable. Sufficient scans were taken to show the out-of-band Emissions, if any, up to 10th harmonic. Multiple sweeps were recorded in maximum hold mode using a peak detector to ensure that the worst-case emissions were caught.

MODES TESTED

GSM, WCDMA

RESULTS

10.3.1. OUT OF BAND EMISSIONS RESULT

GSM

Band	Mode	f (MHz)	Spur (dBm)	Spec (dBm)	Delta (dB)
GSM850	GPRS	824.2	-24.90	-13	-11.90
		836.6	-24.92	-13	-11.92
		848.8	-23.87	-13	-10.87
GSM1900	GPRS	1850.2	-24.41	-13	-11.41
		1880	-23.08	-13	-10.08
		1909.8	-24.40	-13	-11.40

WCDMA

Band	Mode	f (MHz)	Spur (dBm)	Spec (dBm)	Delta (dB)
Band 5	REL99	826.4	-34.55	-13	-21.55
		836.6	-34.41	-13	-21.41
		846.6	-34.59	-13	-21.59
	HSDPA	826.4	-24.52	-13	-11.52
		836.6	-24.50	-13	-11.50
		846.6	-24.63	-13	-11.63
Band 2	REL99	1852.4	-35.15	-13	-22.15
		1880.0	-34.70	-13	-21.70
		1907.6	-34.80	-13	-21.80
	HSDPA	1852.4	-23.67	-13	-10.67
		1880.0	-24.76	-13	-11.76
		1907.6	-23.25	-13	-10.25

10.3.2. OUT OF BAND EMISSIONS PLOTS

GSM

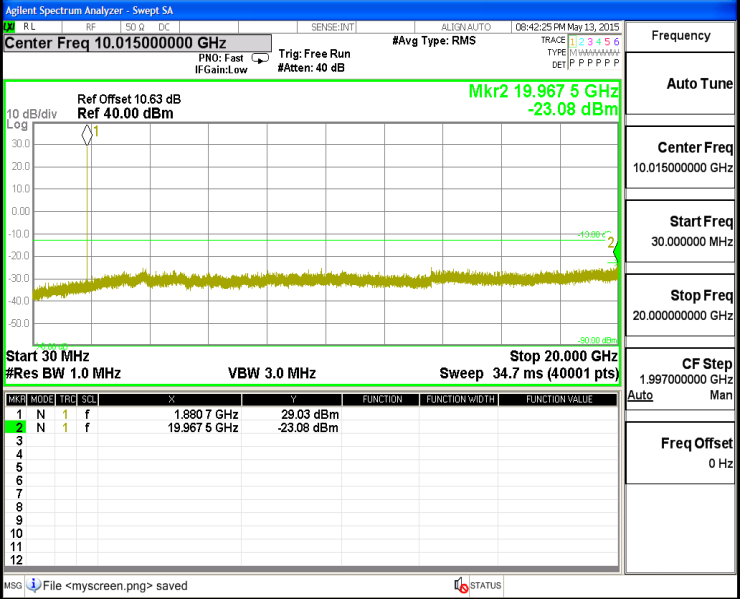
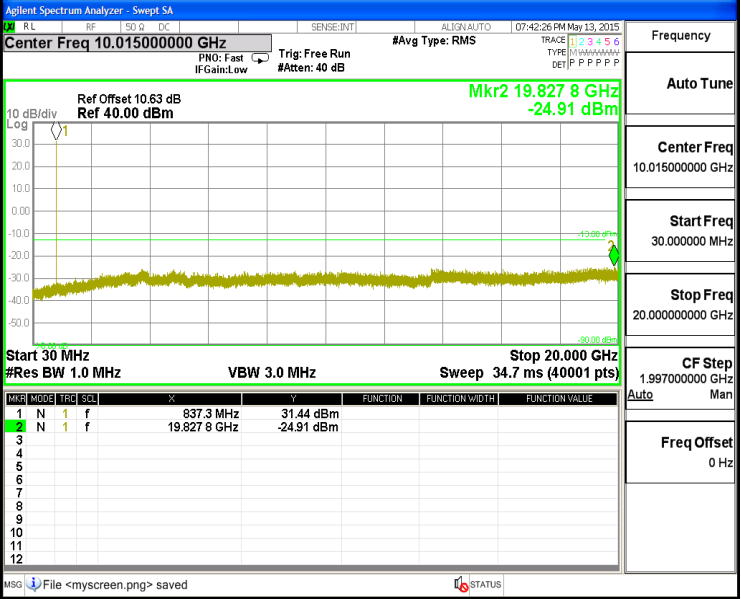
<p>Band GSM1900</p>	 <p>Band GSM1900 GPRS CSE Mid channel</p>
<p>Band GSM850</p>	 <p>Band GSM850 GPRS CSE Mid channel</p>

WCDMA

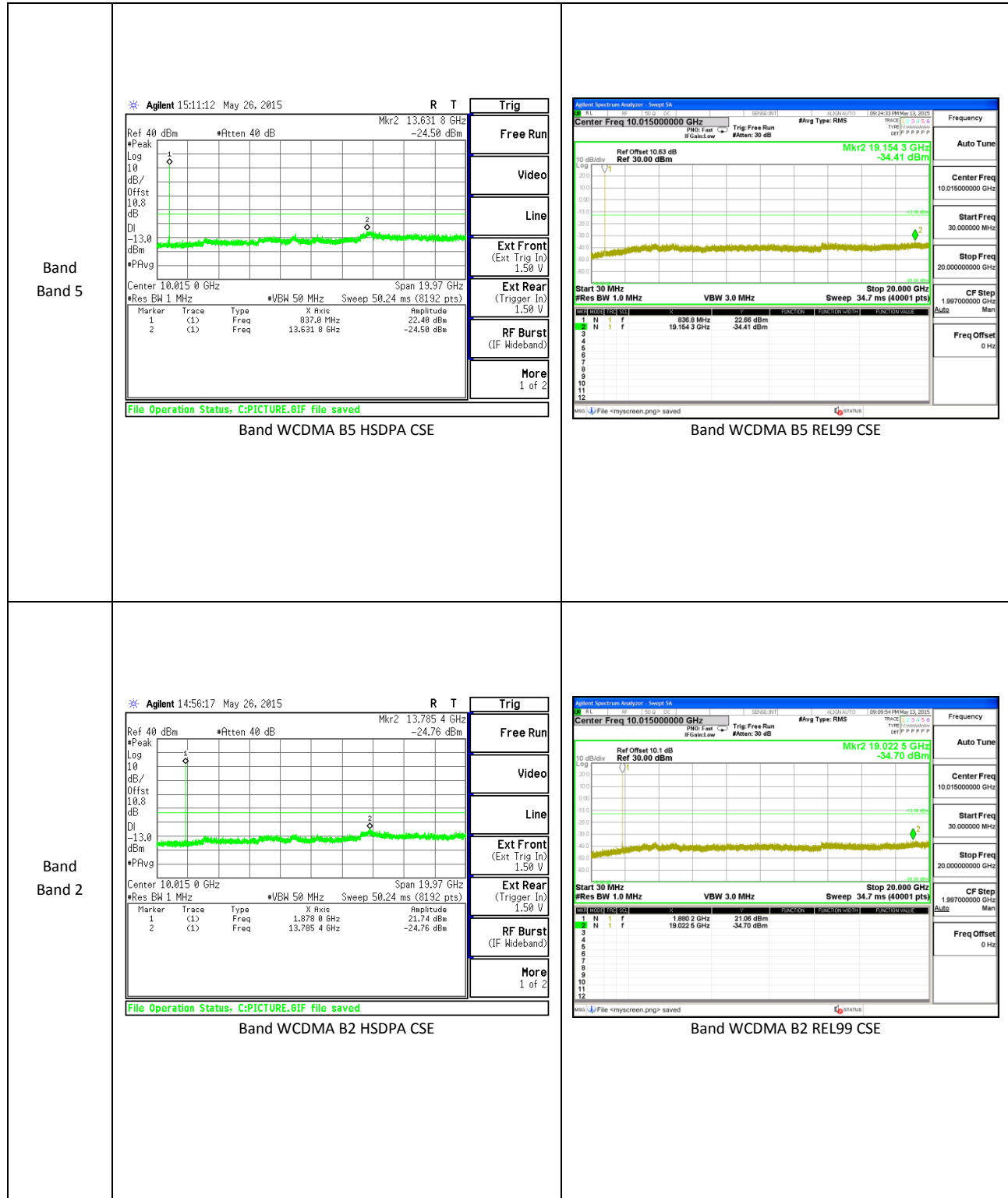

10.4. FREQUENCY STABILITY

RULE PART(S)

FCC: §2.1055, §22.355, §24.235

LIMITS

§22.355 - The carrier frequency shall not depart from the reference frequency in excess of ± 2.5 ppm for mobile stations.

§24.235 - The frequency stability shall be sufficient to ensure that the fundamental emission stays within the authorized frequency block.

TEST PROCEDURE

Per KDB 971168 D01 Power Meas License Digital Systems v02r02

MODES TESTED

GSM, WCDMA

RESULTS

See the following pages.

10.4.1. FREQUENCY STABILITY RESULTS

GPRS 850, MID CHANNEL

Reference Frequency: PCS Mid Channel		836.6	MHz @ 20°C	
Limit: to stay +/- 2.5 ppm =		2091.500	Hz	
Power Supply (Vdc)	Environment Temperature (°C)	Frequency Deviation Measured with Time Elapse		
		(MHz)	Delta (ppm)	Limit (ppm)
3.80	50	836.600030	-0.074	2.5
3.80	40	836.599973	-0.007	2.5
3.80	30	836.599973	-0.007	2.5
3.80	20	836.599968	0	2.5
3.80	10	836.599979	-0.014	2.5
3.80	0	836.599980	-0.015	2.5
3.80	-10	836.599989	-0.026	2.5
3.80	-20	836.599990	-0.027	2.5
3.80	-30	836.599980	-0.014	2.5

Reference Frequency: PCS Mid Channel		836.6	MHz @ 20°C	
Limit: to stay +/- 2.5 ppm =		2091.500	Hz	
Power Supply (Vdc)	Environment Temperature (°C)	Frequency Deviation Measured with Time Elapse		
		(MHz)	Delta (ppm)	Limit (ppm)
3.80	20	836.599968	0	2.5
4.37	20	836.599982	-0.017	2.5
3.23(End of volt)	20	836.5999543	0.016	2.5

GPRS 1900, MID CHANNEL

Reference Frequency: PCS Mid Channel 1880 MHz @ 20°C Limit: to stay +- 2.5 ppm = 4700.000 Hz				
Power Supply (Vdc)	Environment Temperature (°C)	Frequency Deviation Measured with Time Elapse		
		(MHz)	Delta (ppm)	Limit (ppm)
3.80	50	1879.999971	-0.007	2.5
3.80	40	1879.999982	-0.012	2.5
3.80	30	1879.999980	-0.012	2.5
3.80	20	1879.999959	0	2.5
3.80	10	1879.999947	0.006	2.5
3.80	0	1879.999951	0.004	2.5
3.80	-10	1879.999944	0.008	2.5
3.80	-20	1879.999924	0.018	2.5
3.80	-30	1879.999920	0.021	2.5

Reference Frequency: PCS Mid Channel 1880 MHz @ 20°C Limit: to stay +- 2.5 ppm = 4700.000 Hz				
Power Supply (Vdc)	Environment Temperature (°C)	Frequency Deviation Measured with Time Elapse		
		(MHz)	Delta (ppm)	Limit (ppm)
3.80	20	1879.999959	0	2.5
4.37	20	1879.999964	-0.003	2.5
3.23(End of volt)	20	1879.999943	0.008	2.5

11. RADIATED TEST RESULTS

11.1. RADIATED POWER (ERP & EIRP)

RULE PART(S)

FCC: §2.1046, §22.913, §24.232.

LIMITS

22.913(a) - The ERP of mobile transmitters and auxiliary test transmitters must not exceed 7 Watts.

24.232(c) - Mobile/portable stations are limited to 2 watts e.i.r.p. peak power and the equipment must employ means to limit the power to the minimum necessary for successful communications.

TEST PROCEDURE

ANSI / TIA / EIA 603C Clause 2.2.17; PSA setting reference to 971168 D01 v02r02

For peak power measurement with a PSA:

a) Set the RBW \geq OBW; b) Set VBW $\geq 3 \times$ RBW; c) Set span $\geq 2 \times$ RBW; d) Sweep time = auto couple; e) Detector = peak; f) Ensure that the number of measurement points \geq span/RBW; g) Trace mode = max hold;

For average power measurement with a PSA:

a) Set span to at least 1.5 times the OBW; b) Set RBW = 1-5% of the OBW, not to exceed 1 MHz; c) Set VBW $\geq 3 \times$ RBW; d) Set number of points in sweep $\geq 2 \times$ span / RBW; e) Sweep time = auto-couple; f) Detector = RMS (power averaging); g) Use free run trigger If burst duty cycle ≥ 98 ; h) Use trigger to capture bursts If burst duty cycle < 98 ; i) Trace average at least 100 traces in power averaging (*i.e.*, RMS) mode. j) Compute the power by integrating the spectrum across the OBW of the signal using the instrument's band power measurement function.

MODES TESTED

GSM, WCDMA

TEST RESULTS

11.1.1. ERP/EIRP Results

GSM

Band	Mode	Channel	f(MHz)	ERP	
				dBm	mW
GSM850	GPRS	128	824.2	29.701	933.47
		190	836.6	29.591	910.12
		251	848.8	30.041	1009.49
Band	Mode	Channel	f(MHz)	EIRP	
				dBm	mW
GSM1900	GPRS	512	1850.2	28.5	707.95
		661	1880	29.77	948.42
		810	1909.8	29.87	970.51

WCDMA

Band	Mode	Channel	f(MHz)	EIRP	
				dBm	mW
Band 2	REL99	9262	1852.4	20.91	123.31
		9400	1880.0	21.51	141.58
		9538	1907.6	21.85	153.11
	HSDPA	9262	1852.4	20.43	110.41
		9400	1880.0	21.36	136.77
		9538	1907.6	21.76	149.97
Band	Mode	Channel	f(MHz)	ERP	
				dBm	mW
Band 5	REL99	4132	826.4	21.176	131.10
		4183	836.6	20.811	120.53
		4233	846.6	21.474	140.41
	HSDPA	4132	826.4	20.790	119.95
		4183	836.6	20.960	124.74
		4233	846.6	21.120	129.42

11.1.2. ERP/EIRP PLOTS

GSM

Band GSM 1900 GPRS	<p>High Frequency Substitution Measurement UL Verification Services, Inc.</p> <p>Company: LG Project #: 15I20528 Date: 5/11/2015 Test Engineer: D. Mun Configuration: EUT X-pos Mode: GPRS 1900</p> <p>Test Equipment: Receiving: Horn T119, and Chamber C SMA Cables Substitution: Horn T59 Substitution, 4ft SMA Cable Warehouse</p>								
	f MHz	SG reading (dBm)	Ant. Pol. (H/V)	Cable Loss (dB)	Antenna Gain (dBi)	EIRP (dBm)	Limit (dBm)	Margin (dB)	Notes
	Low Ch								
	1850.20	15.06	V	0.9	8.0	22.22	33.0	-10.8	
	1850.20	21.34	H	0.9	8.0	28.50	33.0	-4.5	
	Mid Ch								
	1880.00	15.15	V	0.9	8.0	22.31	33.0	-10.7	
	1880.00	22.61	H	0.9	8.0	29.77	33.0	-3.2	
	High Ch								
	1909.80	15.32	V	0.9	8.0	22.48	33.0	-10.5	
	1909.80	22.71	H	0.9	8.0	29.87	33.0	-3.1	
	Rev. 3.17.11 Note: For Band 4 EIRP limit is 30dBm								

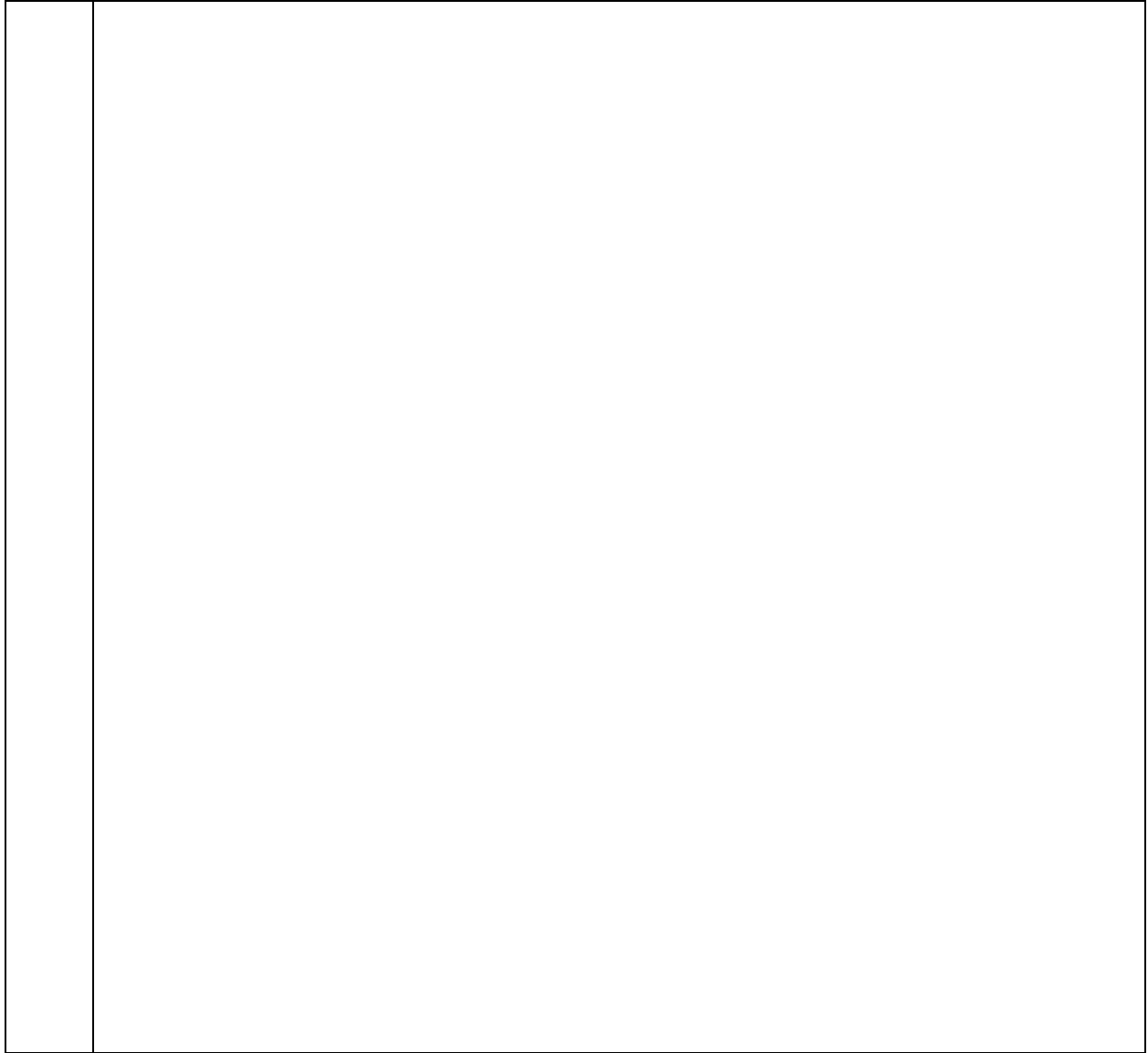

Band GSM 1900 GPRS	High Frequency Substitution Measurement UL Verification Services, Inc.								
	Company: LG Project #: 15I20528 Date: 5/11/2015 Test Engineer: D. Mun Configuration: EUT X-pos Mode: GPRS 1900								
	Test Equipment: Receiving: Horn T119, and Chamber C SMA Cables Substitution: Horn T59 Substitution, 4ft SMA Cable Warehouse								
	f MHz	SG reading (dBm)	Ant. Pol. (H/V)	Cable Loss (dB)	Antenna Gain (dBi)	EIRP (dBm)	Limit (dBm)	Margin (dB)	Notes
	Low Ch								
	1850.20	15.06	V	0.9	8.0	22.22	33.0	-10.8	
	1850.20	21.34	H	0.9	8.0	28.50	33.0	-4.5	
	Mid Ch								
	1880.00	15.15	V	0.9	8.0	22.31	33.0	-10.7	
	1880.00	22.61	H	0.9	8.0	29.77	33.0	-3.2	
High Ch									
1909.80	15.32	V	0.9	8.0	22.48	33.0	-10.5		
1909.80	22.71	H	0.9	8.0	29.87	33.0	-3.1		
Rev. 3.17.11 Note: For Band 4 EIRP limit is 30dBm									

Band GSM 850 GPRS	High Frequency Substitution Measurement UL Verification Services, Inc. Chamber C																																																																																																	
	Company:		LG																																																																																															
	Project #:		15I20528																																																																																															
	Date:		05/12/15																																																																																															
	Test Engineer:		David Mun																																																																																															
	Configuration:		EUT X-Position																																																																																															
	Mode:		GPRS850																																																																																															
	Test Equipment:																																																																																																	
	Receiving: Hybrid T185, and Chamber C N-type Cable																																																																																																	
	Substitution: Dipole T273, 8ft SMA Cable Warehouse.																																																																																																	
<table border="1"> <thead> <tr> <th>f MHz</th> <th>SG reading (dBm)</th> <th>Ant. Pol. (H/V)</th> <th>Cable Loss (dB)</th> <th>Antenna Gain (dBd)</th> <th>ERP (dBm)</th> <th>Limit (dBm)</th> <th>Margin (dB)</th> <th>Notes</th> </tr> </thead> <tbody> <tr> <td colspan="9">Low Ch</td> </tr> <tr> <td>824.20</td> <td>13.30</td> <td>V</td> <td>0.9</td> <td>0.0</td> <td>12.40</td> <td>38.5</td> <td>-26.0</td> <td></td> </tr> <tr> <td>824.20</td> <td>30.60</td> <td>H</td> <td>0.9</td> <td>0.0</td> <td>29.70</td> <td>38.5</td> <td>-8.7</td> <td></td> </tr> <tr> <td colspan="9">Mid Ch</td> </tr> <tr> <td>836.60</td> <td>14.20</td> <td>V</td> <td>0.9</td> <td>0.0</td> <td>13.30</td> <td>38.5</td> <td>-25.1</td> <td></td> </tr> <tr> <td>836.60</td> <td>30.49</td> <td>H</td> <td>0.9</td> <td>0.0</td> <td>29.59</td> <td>38.5</td> <td>-8.9</td> <td></td> </tr> <tr> <td colspan="9">High Ch</td> </tr> <tr> <td>848.80</td> <td>14.00</td> <td>V</td> <td>0.9</td> <td>0.0</td> <td>13.10</td> <td>38.5</td> <td>-25.3</td> <td></td> </tr> <tr> <td>848.80</td> <td>30.94</td> <td>H</td> <td>0.9</td> <td>0.0</td> <td>30.04</td> <td>38.5</td> <td>-8.4</td> <td></td> </tr> </tbody> </table>									f MHz	SG reading (dBm)	Ant. Pol. (H/V)	Cable Loss (dB)	Antenna Gain (dBd)	ERP (dBm)	Limit (dBm)	Margin (dB)	Notes	Low Ch									824.20	13.30	V	0.9	0.0	12.40	38.5	-26.0		824.20	30.60	H	0.9	0.0	29.70	38.5	-8.7		Mid Ch									836.60	14.20	V	0.9	0.0	13.30	38.5	-25.1		836.60	30.49	H	0.9	0.0	29.59	38.5	-8.9		High Ch									848.80	14.00	V	0.9	0.0	13.10	38.5	-25.3		848.80	30.94	H	0.9	0.0	30.04	38.5	-8.4	
f MHz	SG reading (dBm)	Ant. Pol. (H/V)	Cable Loss (dB)	Antenna Gain (dBd)	ERP (dBm)	Limit (dBm)	Margin (dB)	Notes																																																																																										
Low Ch																																																																																																		
824.20	13.30	V	0.9	0.0	12.40	38.5	-26.0																																																																																											
824.20	30.60	H	0.9	0.0	29.70	38.5	-8.7																																																																																											
Mid Ch																																																																																																		
836.60	14.20	V	0.9	0.0	13.30	38.5	-25.1																																																																																											
836.60	30.49	H	0.9	0.0	29.59	38.5	-8.9																																																																																											
High Ch																																																																																																		
848.80	14.00	V	0.9	0.0	13.10	38.5	-25.3																																																																																											
848.80	30.94	H	0.9	0.0	30.04	38.5	-8.4																																																																																											
Rev. 3.17.11																																																																																																		
Note: For Band 13/17 ERP limit is 34.77dBm; For Band 26 limit is 50dBm																																																																																																		

WCDMA

Band
 Band 2
 HSDPA

High Frequency Substitution Measurement UL Verification Services, Inc.								
Company:		LG						
Project #:		15I20528						
Date:		5/22/2015						
Test Engineer:		D. Mun						
Configuration:		X-pos EUT Only						
Location:		Chamber A						
Mode:		HSDPA B2						
Test Equipment:								
Receiving: Horn T119, and Chamber C SMA Cables								
Substitution: Horn T59 Substitution, 4ft SMA Cable Warehouse								
f MHz	SG reading (dBm)	Ant. Pol. (H/V)	Cable Loss (dB)	Antenna Gain (dBi)	EIRP (dBm)	Limit (dBm)	Margin (dB)	Notes
Low Ch								
1852.40	5.70	V	0.9	8.0	12.81	33.0	-20.2	
1852.40	13.32	H	0.9	8.0	20.43	33.0	-12.6	
Mid Ch								
1880.00	5.98	V	0.9	8.0	13.09	33.0	-19.9	
1880.00	14.25	H	0.9	8.0	21.36	33.0	-11.6	
High Ch								
1907.60	7.60	V	0.9	8.0	14.71	33.0	-18.3	
1907.60	14.65	H	0.9	8.0	21.76	33.0	-11.2	
Rev. 3.17.11								
Note: For Band 4 EIRP limit is 30dBm								

Band
 Band 2
 REL99

**High Frequency Substitution Measurement
 UL Verification Services, Inc.**

Company: LG
Project #: 15I20528
Date: 5/11/2015
Test Engineer: D. Mun
Configuration: X-pos EUT Only
Location: Chamber C
Mode: Rel99 B2

Test Equipment:

Receiving: Horn T119, and Chamber C SMA Cables
Substitution: Horn T59 Substitution, 4ft SMA Cable Warehouse

f MHz	SG reading (dBm)	Ant. Pol. (H/V)	Cable Loss (dB)	Antenna Gain (dBi)	EIRP (dBm)	Limit (dBm)	Margin (dB)	Notes
Low Ch								
1852.40	4.62	V	0.9	8.0	11.73	33.0	-21.3	
1852.40	13.80	H	0.9	8.0	20.91	33.0	-12.1	
Mid Ch								
1880.00	4.68	V	0.9	8.0	11.79	33.0	-21.2	
1880.00	14.40	H	0.9	8.0	21.51	33.0	-11.5	
High Ch								
1907.60	5.13	V	0.9	8.0	12.24	33.0	-20.8	
1907.60	14.74	H	0.9	8.0	21.85	33.0	-11.2	

Rev. 3.17.11
 Note: For Band 4 EIRP limit is 30dBm

Band Band 5 HSDPA	High Frequency Substitution Measurement UL Verification Services, Inc. Chamber A																																																																																																					
	Company:		LG																																																																																																			
	Project #:		15I20528																																																																																																			
	Date:		05/22/15																																																																																																			
	Test Engineer:		D. Mun																																																																																																			
	Configuration:		EUT only X orientation																																																																																																			
	Mode:		HSDPA B5 FUND																																																																																																			
	Test Equipment:																																																																																																					
	Receiving: Hybrid T130, and Chamber A N-type Cable																																																																																																					
	Substitution: Dipole T273, 8ft SMA Cable Warehouse.																																																																																																					
<table border="1" style="width: 100%; border-collapse: collapse;"> <thead> <tr> <th style="width: 10%;">f MHz</th> <th style="width: 10%;">SG reading (dBm)</th> <th style="width: 10%;">Ant. Pol. (H/V)</th> <th style="width: 10%;">Cable Loss (dB)</th> <th style="width: 10%;">Antenna Gain (dBd)</th> <th style="width: 10%;">ERP (dBm)</th> <th style="width: 10%;">Limit (dBm)</th> <th style="width: 10%;">Margin (dB)</th> <th style="width: 10%;">Notes</th> </tr> </thead> <tbody> <tr> <td colspan="10">Low Ch</td> </tr> <tr> <td>826.40</td> <td>10.00</td> <td>V</td> <td>0.9</td> <td>0.0</td> <td>9.10</td> <td>38.5</td> <td>-29.3</td> <td></td> </tr> <tr> <td>826.40</td> <td>21.69</td> <td>H</td> <td>0.9</td> <td>0.0</td> <td>20.79</td> <td>38.5</td> <td>-17.7</td> <td></td> </tr> <tr> <td colspan="10">Mid Ch</td> </tr> <tr> <td>836.60</td> <td>10.90</td> <td>V</td> <td>0.9</td> <td>0.0</td> <td>10.00</td> <td>38.5</td> <td>-28.4</td> <td></td> </tr> <tr> <td>836.60</td> <td>21.86</td> <td>H</td> <td>0.9</td> <td>0.0</td> <td>20.96</td> <td>38.5</td> <td>-17.5</td> <td></td> </tr> <tr> <td colspan="10">High Ch</td> </tr> <tr> <td>846.60</td> <td>11.00</td> <td>V</td> <td>0.9</td> <td>0.0</td> <td>10.10</td> <td>38.5</td> <td>-28.3</td> <td></td> </tr> <tr> <td>846.60</td> <td>22.02</td> <td>H</td> <td>0.9</td> <td>0.0</td> <td>21.12</td> <td>38.5</td> <td>-17.3</td> <td></td> </tr> </tbody> </table>										f MHz	SG reading (dBm)	Ant. Pol. (H/V)	Cable Loss (dB)	Antenna Gain (dBd)	ERP (dBm)	Limit (dBm)	Margin (dB)	Notes	Low Ch										826.40	10.00	V	0.9	0.0	9.10	38.5	-29.3		826.40	21.69	H	0.9	0.0	20.79	38.5	-17.7		Mid Ch										836.60	10.90	V	0.9	0.0	10.00	38.5	-28.4		836.60	21.86	H	0.9	0.0	20.96	38.5	-17.5		High Ch										846.60	11.00	V	0.9	0.0	10.10	38.5	-28.3		846.60	22.02	H	0.9	0.0	21.12	38.5	-17.3	
f MHz	SG reading (dBm)	Ant. Pol. (H/V)	Cable Loss (dB)	Antenna Gain (dBd)	ERP (dBm)	Limit (dBm)	Margin (dB)	Notes																																																																																														
Low Ch																																																																																																						
826.40	10.00	V	0.9	0.0	9.10	38.5	-29.3																																																																																															
826.40	21.69	H	0.9	0.0	20.79	38.5	-17.7																																																																																															
Mid Ch																																																																																																						
836.60	10.90	V	0.9	0.0	10.00	38.5	-28.4																																																																																															
836.60	21.86	H	0.9	0.0	20.96	38.5	-17.5																																																																																															
High Ch																																																																																																						
846.60	11.00	V	0.9	0.0	10.10	38.5	-28.3																																																																																															
846.60	22.02	H	0.9	0.0	21.12	38.5	-17.3																																																																																															
Rev. 3.17.11 Note: For Band 13/17 ERP limit is 34.77dBm; For Band 26 limit is 50dBm																																																																																																						

Band
 Band 5
 REL99

**High Frequency Substitution Measurement
 UL Verification Services, Inc. Chamber A**

Company: LG
Project #: 15I20528
Date: 05/14/15
Test Engineer: Charles Vergonio
Configuration: EUT only X orientation
Mode: REL99 B5 FUND

Test Equipment:

Receiving: Hybrid T130, and Chamber A N-type Cable
Substitution: Dipole T273, 8ft SMA Cable Warehouse.

f MHz	SG reading (dBm)	Ant. Pol. (H/V)	Cable Loss (dB)	Antenna Gain (dBd)	ERP (dBm)	Limit (dBm)	Margin (dB)	Notes
Low Ch								
826.40	11.38	V	0.9	0.0	10.48	38.5	-28.0	
826.40	22.08	H	0.9	0.0	21.18	38.5	-17.3	
Mid Ch								
836.60	11.85	V	0.9	0.0	10.95	38.5	-27.5	
836.60	21.71	H	0.9	0.0	20.81	38.5	-17.6	
High Ch								
846.60	12.34	V	0.9	0.0	11.45	38.5	-27.0	
846.60	22.37	H	0.9	0.0	21.47	38.5	-17.0	

Rev. 3.17.11

Note: For Band 13/17 ERP limit is 34.77dBm; For Band 26 limit is 50dBm

11.2. FIELD STRENGTH OF SPURIOUS RADIATION

RULE PART(S)

FCC: §2.1053, §22.917 and §24.238

LIMIT

The power of any emission outside of the authorized operating frequency ranges must be attenuated below the transmitting power (P) by a factor of at least $43 + 10 \log (P)$ dB.

TEST PROCEDURE

For Cellular equipment - Compliance with these rules is based on the use of measurement instrumentation employing a resolution bandwidth of 100 kHz or greater. In the 1 MHz bands immediately outside and adjacent to the frequency block a resolution bandwidth of at least one percent of the emission bandwidth of the fundamental emission of the transmitter may be employed. A narrower resolution bandwidth is permitted in all cases to improve measurement accuracy provided the measured power is integrated over the full required measurement bandwidth (i.e. 100 kHz or 1 percent of emission bandwidth, as specified). The emission bandwidth is defined as the width of the signal between two points, one below the carrier center frequency and one above the carrier center frequency, outside of which all emissions are attenuated at least 26 dB below the transmitter power.

For PCS equipment - Compliance with these rules is based on the use of measurement instrumentation employing a resolution bandwidth of 1 MHz or greater. However, in the 1 MHz bands immediately outside and adjacent to the frequency block a resolution bandwidth of at least one percent of the emission bandwidth of the fundamental emission of the transmitter may be employed. A narrower resolution bandwidth is permitted in all cases to improve measurement accuracy provided the measured power is integrated over the full required measurement bandwidth (i.e. 1 MHz or 1 percent of emission bandwidth, as specified). The emission bandwidth is defined as the width of the signal between two points, one below the carrier center frequency and one above the carrier center frequency, outside of which all emissions are attenuated at least 26 dB below the transmitter power.

MODES TESTED

GSM, WCDMA

RESULTS

11.2.1. SPURIOUS RADIATION PLOTS

GSM

UL Verification Services, Inc. Above 1GHz High Frequency Substitution Measurement									
Company:		LG Electronics							
Project #:		15I20528							
Date:		5/14/2015							
Test Engineer:		Charles Vergonio							
Configuration:		X-pos EUT w/ AC Adapter + Headset							
Mode:		GPRS1900							
Chamber		Pre-amplifier		Filter		Limit			
5m Chamber A		T34 8449B		Filter 1		Part 24			
f GHz	SG reading (dBm)	Ant. Pol. (H/V)	Distance (m)	Preamp (dB)	Filter (dB)	EIRP (dBm)	Limit (dBm)	Delta (dB)	Notes
Low Ch, 1850.2MHz									
3.700	-10.3	V	3.0	35.4	1.0	-44.7	-13.0	-31.7	
5.551	-9.1	V	3.0	34.7	1.0	-42.8	-13.0	-29.8	
7.401	-7.5	V	3.0	34.9	1.0	-41.5	-13.0	-28.5	
3.700	-9.9	H	3.0	35.4	1.0	-44.3	-13.0	-31.3	
5.551	-6.3	H	3.0	34.7	1.0	-40.0	-13.0	-27.0	
7.401	-6.5	H	3.0	34.9	1.0	-40.4	-13.0	-27.4	
Mid Ch, 1880.0MHz									
3.760	-10.1	V	3.0	35.3	1.0	-44.4	-13.0	-31.4	
5.640	-8.8	V	3.0	34.7	1.0	-42.6	-13.0	-29.6	
7.520	-7.3	V	3.0	34.9	1.0	-41.3	-13.0	-28.3	
3.760	-9.7	H	3.0	35.3	1.0	-44.0	-13.0	-31.0	
5.640	-6.0	H	3.0	34.7	1.0	-39.7	-13.0	-26.7	
7.520	-6.7	H	3.0	34.9	1.0	-40.7	-13.0	-27.7	
High Ch, 1909.8MHz									
3.820	-10.0	V	3.0	35.3	1.0	-44.3	-13.0	-31.3	
5.729	-8.8	V	3.0	34.7	1.0	-42.5	-13.0	-29.5	
7.639	-7.2	V	3.0	35.0	1.0	-41.2	-13.0	-28.2	
3.820	-9.6	H	3.0	35.3	1.0	-43.9	-13.0	-30.9	
5.729	-5.5	H	3.0	34.7	1.0	-39.3	-13.0	-26.3	
7.639	-6.6	H	3.0	35.0	1.0	-40.5	-13.0	-27.5	
Rev. 03.03.09									
Note: No other emissions were detected above the system noise floor.									

Band
 GSM
 1900
 GPRS

UL Verification Services, Inc.										
Above 1GHz High Frequency Substitution Measurement										
Company:		LG Electronics								
Project #:		15I20286								
Date:		5/14/2015								
Test Engineer:		Charles Vergonio								
Configuration:		X-pos EUT w/ AC Adapter + Headset								
Location:		Chamber A								
Mode:		GPRS 850 MHz Harmonics								
f MHz	SG reading (dBm)	Ant. Pol. (H/V)	Distance (m)	Preamp (dB)	Filter (dB)	EIRP (dBm)	Limit (dBm)	Delta (dB)	Notes	
Low Ch, 824.2										
1648.40	-10.3	V	3.0	37.0	1.0	-46.3	-13.0	-33.3		
2472.60	-9.4	V	3.0	36.4	1.0	-44.8	-13.0	-31.8		
3296.80	-9.4	V	3.0	36.2	1.0	-44.5	-13.0	-31.5		
1648.40	-10.0	H	3.0	37.0	1.0	-46.0	-13.0	-33.0		
2472.60	-11.4	H	3.0	36.4	1.0	-46.8	-13.0	-33.8		
3296.80	-9.2	H	3.0	36.2	1.0	-44.3	-13.0	-31.3		
Mid Ch, 836.6										
1673.20	-13.7	V	3.0	37.0	1.0	-49.7	-13.0	-36.7		
2509.80	-11.6	V	3.0	36.4	1.0	-47.0	-13.0	-34.0		
3346.40	-6.1	V	3.0	36.1	1.0	-41.3	-13.0	-28.3		
1673.20	-14.9	H	3.0	37.0	1.0	-50.9	-13.0	-37.9		
2509.80	-12.3	H	3.0	36.4	1.0	-47.7	-13.0	-34.7		
3346.40	-6.5	H	3.0	36.1	1.0	-41.6	-13.0	-28.6		
High Ch, 848.8										
1697.60	-12.4	V	3.0	37.0	1.0	-48.4	-13.0	-35.4		
2546.40	-8.1	V	3.0	36.4	1.0	-43.6	-13.0	-30.6		
3395.20	-9.8	V	3.0	36.1	1.0	-44.8	-13.0	-31.8		
1697.60	-11.8	H	3.0	37.0	1.0	-47.8	-13.0	-34.8		
2546.40	-9.7	H	3.0	36.4	1.0	-45.1	-13.0	-32.1		
3395.20	-9.1	H	3.0	36.1	1.0	-44.2	-13.0	-31.2		

Band
GSM
850
GPRS

WCDMA

UL Verification Services, Inc. Above 1GHz High Frequency Substitution Measurement									
Company:		LG Electronics							
Project #:		15I20528							
Date:		5/22/2015							
Test Engineer:		D. Mun							
Configuration:		X-pos EUT w/ AC Adapter							
Mode:		HSDPA B2							
Chamber		Pre-amplifier			Filter		Limit		
5m Chamber A		T34 8449B			Filter 1		Part 24		
f GHz	SG reading (dBm)	Ant. Pol. (H/V)	Distance (m)	Preamp (dB)	Filter (dB)	EIRP (dBm)	Limit (dBm)	Delta (dB)	Notes
Low Ch, 1852.4MHz									
3.705	-11.1	V	3.0	35.4	1.0	-45.5	-13.0	-32.5	
5.557	-8.1	V	3.0	34.7	1.0	-41.8	-13.0	-28.8	
7.410	-8.8	V	3.0	34.9	1.0	-42.7	-13.0	-29.7	
3.705	-11.1	H	3.0	35.4	1.0	-45.5	-13.0	-32.5	
5.557	-10.0	H	3.0	34.7	1.0	-43.7	-13.0	-30.7	
7.410	-6.9	H	3.0	34.9	1.0	-40.8	-13.0	-27.8	
Mid Ch, 1880MHz									
3.760	-10.8	V	3.0	35.3	1.0	-45.1	-13.0	-32.1	
5.640	-7.0	V	3.0	34.7	1.0	-40.7	-13.0	-27.7	
7.520	-6.9	V	3.0	34.9	1.0	-40.9	-13.0	-27.9	
3.760	-9.9	H	3.0	35.3	1.0	-44.2	-13.0	-31.2	
5.640	-7.9	H	3.0	34.7	1.0	-41.6	-13.0	-28.6	
7.520	-6.6	H	3.0	34.9	1.0	-40.6	-13.0	-27.6	
High Ch, 1907.6MHz									
3.815	-10.5	V	3.0	35.3	1.0	-44.8	-13.0	-31.8	
5.723	-7.7	V	3.0	34.7	1.0	-41.5	-13.0	-28.5	
7.630	-6.9	V	3.0	34.9	1.0	-40.9	-13.0	-27.9	
3.815	-10.0	H	3.0	35.3	1.0	-44.2	-13.0	-31.2	
5.723	-7.4	H	3.0	34.7	1.0	-41.2	-13.0	-28.2	
7.630	-6.8	H	3.0	34.9	1.0	-40.8	-13.0	-27.8	
Rev. 03.03.09									
Note: No other emissions were detected above the system noise floor.									

Band
 Band 2
 HSDPA

UL Verification Services, Inc.
Above 1GHz High Frequency Substitution Measurement

Company: LG Electronics
Project #: 15I20528
Date: 5/14/2015
Test Engineer: Charles Vergonio
Configuration: X-pos EUT w/ AC Adapter
Mode: Rel99_B2

Chamber	Pre-amplifier	Filter	Limit
5m Chamber A	T34 8449B	Filter 1	Part 24

f GHz	SG reading (dBm)	Ant. Pol. (H/V)	Distance (m)	Preamp (dB)	Filter (dB)	EIRP (dBm)	Limit (dBm)	Delta (dB)	Notes
Low Ch, 1852.4MHz									
3.705	-10.4	V	3.0	35.4	1.0	44.8	-13.0	-31.8	
5.557	-9.4	V	3.0	34.7	1.0	43.2	-13.0	-30.2	
7.410	-8.2	V	3.0	34.9	1.0	42.1	-13.0	-29.1	
3.705	-10.2	H	3.0	35.4	1.0	44.6	-13.0	-31.6	
5.557	-9.3	H	3.0	34.7	1.0	43.0	-13.0	-30.0	
7.410	-7.2	H	3.0	34.9	1.0	41.1	-13.0	-28.1	
Mid Ch, 1880MHz									
3.760	-10.2	V	3.0	35.3	1.0	44.5	-13.0	-31.5	
5.640	-9.1	V	3.0	34.7	1.0	42.9	-13.0	-29.9	
7.520	-7.9	V	3.0	34.9	1.0	41.9	-13.0	-28.9	
3.760	-10.1	H	3.0	35.3	1.0	44.5	-13.0	-31.5	
5.640	-9.0	H	3.0	34.7	1.0	42.8	-13.0	-29.8	
7.520	-7.6	H	3.0	34.9	1.0	41.5	-13.0	-28.5	
High Ch, 1907.6MHz									
3.815	-10.1	V	3.0	35.3	1.0	44.4	-13.0	-31.4	
5.723	-9.0	V	3.0	34.7	1.0	42.8	-13.0	-29.8	
7.630	-7.9	V	3.0	34.9	1.0	41.8	-13.0	-28.8	
3.815	-9.9	H	3.0	35.3	1.0	44.1	-13.0	-31.1	
5.723	-8.6	H	3.0	34.7	1.0	42.3	-13.0	-29.3	
7.630	-7.2	H	3.0	34.9	1.0	41.1	-13.0	-28.1	

Rev. 03.03.09
 Note: No other emissions were detected above the system noise floor.

Band
 Band 2
 REL99

UL Verification Services, Inc. Above 1GHz High Frequency Substitution Measurement										
Company:		LG Electronics								
Project #:		15I20528								
Date:		5/22/2015								
Test Engineer:		D. Mun								
Configuration:		x-pos EUT w/ AC Adapter								
Location:		Chamber A								
Mode:		HSDPA Band 5 Harmonics								
f MHz	SG reading (dBm)	Ant. Pol. (H/V)	Distance (m)	Preamp (dB)	Filter (dB)	EIRP (dBm)	Limit (dBm)	Delta (dB)	Notes	
Low Ch, 826.4										
1652.80	-17.9	V	3.0	37.0	1.0	-54.0	-13.0	-41.0		
2479.20	-11.9	V	3.0	36.4	1.0	-47.4	-13.0	-34.4		
3305.60	-9.0	V	3.0	36.1	1.0	-44.2	-13.0	-31.2		
1652.80	-17.4	H	3.0	37.0	1.0	-53.4	-13.0	-40.4		
2479.20	-13.9	H	3.0	36.4	1.0	-49.4	-13.0	-36.4		
3305.60	-10.4	H	3.0	36.1	1.0	-45.6	-13.0	-32.6		
Mid Ch, 836.6										
1673.20	-17.1	V	3.0	37.0	1.0	-53.1	-13.0	-40.1		
2509.80	-11.7	V	3.0	36.4	1.0	-47.1	-13.0	-34.1		
3346.40	-8.8	V	3.0	36.1	1.0	-43.9	-13.0	-30.9		
1673.20	-16.8	H	3.0	37.0	1.0	-52.8	-13.0	-39.8		
2509.80	-13.7	H	3.0	36.4	1.0	-49.1	-13.0	-36.1		
3346.40	-10.1	H	3.0	36.1	1.0	-45.2	-13.0	-32.2		
High Ch, 846.6										
1693.20	-16.9	V	3.0	37.0	1.0	-52.9	-13.0	-39.9		
2539.80	-11.5	V	3.0	36.4	1.0	-46.9	-13.0	-33.9		
3386.40	-8.9	V	3.0	36.1	1.0	-44.0	-13.0	-31.0		
1693.20	-16.7	H	3.0	37.0	1.0	-52.7	-13.0	-39.7		
2539.80	-13.6	H	3.0	36.4	1.0	-49.0	-13.0	-36.0		
3386.40	-10.0	H	3.0	36.1	1.0	-45.1	-13.0	-32.1		

Band 5
HSDPA

UL Verification Services, Inc. Above 1GHz High Frequency Substitution Measurement									
Company:		LG Electronics							
Project #:		15I20528							
Date:		5/14/2015							
Test Engineer:		Charles Vergonio							
Configuration:		x-pos EUT w/ AC Adapter							
Location:		Chamber A							
Mode:		Rel99 Band 5 Harmonics							
f MHz	SG reading (dBm)	Ant. Pol. (H/V)	Distance (m)	Preamp (dB)	Filter (dB)	EIRP (dBm)	Limit (dBm)	Delta (dB)	Notes
Low Ch, 826.4									
1652.80	-17.8	V	3.0	37.0	1.0	-53.9	-13.0	-40.9	
2479.20	-12.1	V	3.0	36.4	1.0	-47.6	-13.0	-34.6	
3305.60	-9.0	V	3.0	36.1	1.0	-44.1	-13.0	-31.1	
1652.80	-17.0	H	3.0	37.0	1.0	-53.0	-13.0	-40.0	
2479.20	-14.1	H	3.0	36.4	1.0	-49.6	-13.0	-36.6	
3305.60	-10.0	H	3.0	36.1	1.0	-45.2	-13.0	-32.2	
Mid Ch, 836.6									
1673.20	-17.5	V	3.0	37.0	1.0	-53.5	-13.0	-40.5	
2509.80	-11.9	V	3.0	36.4	1.0	-47.3	-13.0	-34.3	
3346.40	-8.8	V	3.0	36.1	1.0	-43.9	-13.0	-30.9	
1673.20	-16.7	H	3.0	37.0	1.0	-52.7	-13.0	-39.7	
2509.80	-14.0	H	3.0	36.4	1.0	-49.4	-13.0	-36.4	
3346.40	-9.9	H	3.0	36.1	1.0	-45.0	-13.0	-32.0	
High Ch, 846.6									
1693.20	-17.3	V	3.0	37.0	1.0	-53.3	-13.0	-40.3	
2539.80	-11.8	V	3.0	36.4	1.0	-47.2	-13.0	-34.2	
3386.40	-8.7	V	3.0	36.1	1.0	-43.8	-13.0	-30.8	
1693.20	-16.6	H	3.0	37.0	1.0	-52.6	-13.0	-39.6	
2539.80	-13.8	H	3.0	36.4	1.0	-49.2	-13.0	-36.2	
3386.40	-9.9	H	3.0	36.1	1.0	-45.0	-13.0	-32.0	

Band 5
REL99