



FCC RADIO TEST REPORT

FCC ID : UZ7TC58B1
Equipment : Touch Computer
Model Name : TC58B1
Applicant : Zebra Technologies Corporation
1 Zebra Plaza, Holtsville, NY 11742
Manufacturer : Zebra Technologies Corporation
1 Zebra Plaza, Holtsville, NY 11742
Standard : FCC 47 CFR Part 2, 22(H), 24(E), 27

The product was received on Mar. 14, 2022 and testing was performed from Apr. 15 2022 to May 31, 2022. We, Sporton International Inc. EMC & Wireless Communications Laboratory, would like to declare that the tested sample has been evaluated in accordance with the test procedures given in ANSI / TIA-603-E and has been in compliance with the applicable technical standards.

The test results in this report apply exclusively to the tested model / sample. Without written approval of Sporton International Inc. EMC & Wireless Communications Laboratory, the test report shall not be reproduced except in full.

Approved by: Louis Wu

Sporton International Inc. EMC & Wireless Communications Laboratory

No. 52, Huaya 1st Rd., Guishan Dist., Taoyuan City 333, Taiwan (R.O.C.)



Table of Contents

History of this test report.....	3
Summary of Test Result.....	4
1 General Description	6
1.1 Product Feature of Equipment Under Test.....	6
1.2 Product Specification of Equipment Under Test.....	7
1.3 Modification of EUT	8
1.4 Emission Designator.....	8
1.5 Testing Location	13
1.6 Applicable Standards.....	13
2 Test Configuration of Equipment Under Test	14
2.1 Test Mode.....	14
2.2 Connection Diagram of Test System.....	17
2.3 Support Unit used in test configuration and system	17
2.4 Measurement Results Explanation Example.....	17
2.5 Frequency List of Low/Middle/High Channels	18
3 Conducted Test Items.....	22
3.1 Measuring Instruments	22
3.2 Conducted Output Power and ERP/EIRP	23
3.3 Peak-to-Average Ratio	24
3.4 Occupied Bandwidth.....	25
3.5 Conducted Band Edge	26
3.6 Conducted Spurious Emission	28
3.7 Frequency Stability	29
4 Radiated Test Items	30
4.1 Measuring Instruments	30
4.2 Radiated Spurious Emission Measurement	32
5 List of Measuring Equipment.....	33
6 Uncertainty of Evaluation.....	35
Appendix A. Test Results of Conducted Test	
Appendix B. Test Results of Radiated Test	
Appendix C. Test Setup Photographs	



Summary of Test Result

Report Clause	Ref Std. Clause	Test Items	Result (PASS/FAIL)	Remark
3.2	§2.1046	Conducted Output Power	Reporting only	-
	§22.913 (a)(2)	Effective Radiated Power (n5)	Pass	
	§27.50 (c)(10)	Effective Radiated Power (n71)		
	§24.232 (c) §27.50 (h)(2)	Equivalent Isotropic Radiated Power (n2) (n7) (n38) (n41)		
	§27.50 (d)(4)	Equivalent Isotropic Radiated Power (n66)		
3.3	§24.232 (d) §27.50 (d)(5)	Peak-to-Average Ratio	Pass	-
3.4	§2.1049	Occupied Bandwidth	Reporting only	-
3.5	§2.1051 §22.917 (a) §24.238 (a) §27.53 (g) §27.53 (h)	Conducted Band Edge Measurement (n2) (n5) (n66) (n71)	Pass	-
	§2.1051 §27.53 (m)(4)	Conducted Band Edge Measurement (n7) (n38) (n41)		
3.6	§2.1051 §22.917 (a) §24.238 (a) §27.53 (g) §27.53 (h)	Conducted Spurious Emission (n2) (n5) (n66) (n71)	Pass	-
	§2.1051 §27.53 (m)(4)	Conducted Spurious Emission (n7) (n38) (n41)		
3.7	§2.1055 §22.355 §24.235 §27.54	Frequency Stability Temperature & Voltage	Pass	-



Report Clause	Ref Std. Clause	Test Items	Result (PASS/FAIL)	Remark
4.2	§2.1053 §22.917 (a) §24.238 (a) §27.53 (g) §27.53 (h)	Radiated Spurious Emission (n2) (n5) (n66) (n71)	Pass	Under limit 4.90 dB at 7775.000 MHz
	§2.1051 §27.53 (m)(4)	Radiated Spurious Emission (n7) (n38) (n41)		

Declaration of Conformity:

1. The test results (PASS/FAIL) with all measurement uncertainty excluded are presented in accordance with the regulation limits or requirements declared by manufacturers. It's means measurement values may risk exceeding the limit of regulation standards, if measurement uncertainty is include in test results.
2. The measurement uncertainty please refer to this report "Uncertainty of Evaluation".

Comments and Explanations:

The product specifications of the EUT presented in the report are declared by the manufacturer who shall take full responsibility for the authenticity.

Reviewed by: Wei Chen

Report Producer: Clio Lo



1 General Description

1.1 Product Feature of Equipment Under Test

Product Feature	
Equipment	Touch Computer
Brand Name	Zebra
Model Name	TC58B1
FCC ID	UZ7TC58B1
Sample 1	Lowell + Premium config
Sample 2	SE4720 + Base config
Sample 3	Lowell + Base config
EUT supports Radios application	GSM/EGPRS/WCDMA/HSPA/LTE/5G NR/NFC/GNSS WLAN 11a/b/g/n HT20/HT40 WLAN 11ac VHT20/VHT40/VHT80/VHT160 WLAN 11ax HE20/HE40/HE80/HE160 Bluetooth BR/EDR/LE
HW Version	EV3
SW Version	athena_A11_userdebug_GMS_RelKey_2022-02-22-2145_p roduct_SE
MFD	26FEB22
EUT Stage	Identical Prototype

Remark: The above EUT's information was declared by manufacturer.

Specification of Accessories				
Adapter	Brand Name	Zebra	Model Name	SAWA-65-20005A
			Part Number	PWR-WUA5V12W0US
Battery 1X	Brand Name	Zebra	Model Name	BT-000442
			Part Number	BT-000442-0020
Battery 1.5X	Brand Name	Zebra	Model Name	BT-000442
			Part Number	BT-000442-0820
USB TYPE A to TYPE C cable	Brand Name	Zebra	Part Number	CBL-TC5X-USBC2A-01
USB TYPE C to 3.5mm audio connector	Brand Name	Zebra	Part Number	ADP-USBC-35MM1-01
3.5mm Earphone	Brand Name	Zebra	Part Number	HDST-35MM-PTVP-01
USB TYPE C Earphone	Brand Name	Zebra	Part Number	HPST-USBC-PTT1-01
Headset Jumper	Brand Name	Zebra	Part Number	CBL-TC51-HDST35-01
Trigger Handle	Brand Name	Zebra	Part Number	TRG-NGTC5-ELEC-01
Soft Holster	Brand Name	Zebra	Part Number	SG-NGTC5TC7-HLSTR-01
TC53/TC58 RUGGED BOOT	Brand Name	Zebra	Part Number	SG-NGTC5EXO1-01

1.2 Product Specification of Equipment Under Test

Product Specification is subject to this standard	
Tx Frequency	5G NR n2: 1852.5 MHz ~ 1907.5 MHz 5G NR n5: 826.5 MHz ~ 846.5 MHz 5G NR n7: 2502.5 MHz ~ 2567.5 MHz 5G NR n38: 2580 MHz ~ 2610 MHz 5G NR n41: 2506.02 MHz ~ 2679.99 MHz 5G NR n66: 1712.5 MHz ~ 1777.5 MHz 5G NR n71: 665.5 MHz ~ 695.5 MHz
Rx Frequency	5G NR n2: 1932.5 MHz ~ 1987.5 MHz 5G NR n5: 871.5 MHz ~ 891.5 MHz 5G NR n7: 2622.5 MHz ~ 2687.5 MHz 5G NR n38: 2580 MHz ~ 2610 MHz 5G NR n41: 2506.02 MHz ~ 2679.99 MHz 5G NR n66: 2112.5 MHz ~ 2197.5 MHz 5G NR n71: 619.5 MHz ~ 649.5 MHz
Bandwidth	5G NR n2: 5MHz / 10MHz / 15MHz / 20MHz 5G NR n5: 5MHz / 10MHz / 15MHz / 20MHz 5G NR n7: 5MHz / 10MHz / 15MHz / 20MHz 5G NR n38: 20MHz / 30MHz / 40MHz 5G NR n41: 20MHz / 30MHz / 40MHz / 50MHz / 60MHz / 80MHz / 90MHz / 100MHz 5G NR n66: 5MHz / 10MHz / 15MHz / 20MHz / 30MHz / 40MHz 5G NR n71: 5MHz / 10MHz / 15MHz / 20MHz
Maximum Output Power to Antenna	5G NR n2 : 24.75 dBm 5G NR n5 : 24.99 dBm 5G NR n7 : 24.37 dBm 5G NR n38 : 23.90 dBm 5G NR n41 : 26.12 dBm 5G NR n66 : 24.45 dBm 5G NR n71 : 24.43 dBm
Antenna Type	PIFA Antenna
Antenna Gain	<Ant. 0> 5G NR n71: -0.52 dBi <Ant. 2> 5G NR n2: -0.07 2.13?dBi 5G NR n66: 2.18 dBi <Ant. 4> 5G NR n5: -2.42 dBi <Ant. 6> 5G NR n7: -1.08 dBi 5G NR n38: -0.54 dBi 5G NR n41: -0.51 dBi <Ant. 12> 5G NR n7: 2.09 dBi
Type of Modulation	PI/2 BPSK / QPSK / 16QAM / 64QAM / 256QAM

Remark: The above EUT's information was declared by manufacturer. Please refer to Comments and Explanations in report summary.



1.3 Modification of EUT

No modifications are made to the EUT during all test items.

1.4 Emission Designator

5G NR n2		PI/2 BPSK			QPSK			16QAM		
BW (MHz)	Frequency Range (MHz)	Emission Designator (99%OBW)	Frequency Tolerance (ppm)	Maximum EIRP(W)	Emission Designator (99%OBW)	Frequency Tolerance (ppm)	Maximum EIRP(W)	Emission Designator (99%OBW)	Frequency Tolerance (ppm)	Maximum EIRP(W)
5	1852.5 ~ 1907.5	4M46F9W	-	0.2825	4M49G7D	-	0.2825	4M52W7D	-	0.2148
10	1855.0 ~ 1905.0	8M91F9W	-	0.2938	9M29G7D	-	0.2938	9M29W7D	-	0.2223
15	1857.5 ~ 1902.5	13M5F9W	-	0.2723	14M1G7D	-	0.2723	14M2W7D	-	0.2089
20	1860.0 ~ 1900.0	17M9F9W	0.0030	0.2748	19M0G7D	-	0.2748	18M9W7D	-	0.2113
5G NR n2		64QAM			256QAM					
BW (MHz)	Frequency Range (MHz)	Emission Designator (99%OBW)	Frequency Tolerance (ppm)	Maximum EIRP(W)	Emission Designator (99%OBW)	Frequency Tolerance (ppm)	Maximum EIRP(W)	Emission Designator (99%OBW)	Frequency Tolerance (ppm)	Maximum EIRP(W)
5	1852.5 ~ 1907.5	4M49W7D	-	0.2148	4M49W7D	-	0.2148	4M49W7D	-	0.2148
10	1855.0 ~ 1905.0	9M30W7D	-	0.2223	9M30W7D	-	0.2223	9M30W7D	-	0.2223
15	1857.5 ~ 1902.5	14M2W7D	-	0.2089	14M1W7D	-	0.2089	14M1W7D	-	0.2089
20	1860.0 ~ 1900.0	19M0W7D	-	0.2113	19M0W7D	-	0.2113	19M0W7D	-	0.2113

5G NR n5		PI/2 BPSK			QPSK			16QAM		
BW (MHz)	Frequency Range (MHz)	Emission Designator (99%OBW)	Frequency Tolerance (ppm)	Maximum ERP(W)	Emission Designator (99%OBW)	Frequency Tolerance (ppm)	Maximum ERP(W)	Emission Designator (99%OBW)	Frequency Tolerance (ppm)	Maximum ERP(W)
5	826.5 ~ 846.5	4M46F9W	-	0.1102	4M48G7D	-	0.1102	4M50W7D	-	0.0817
10	829.0 ~ 844.0	8M90F9W	-	0.1072	9M25G7D	-	0.1072	9M25W7D	-	0.0757
15	831.5 ~ 841.5	13M4F9W	-	0.1069	14M1G7D	-	0.1069	14M2W7D	-	0.0714
20	834.0 ~ 839.0	17M9F9W	0.0078	0.1059	18M9G7D	-	0.1059	18M9W7D	-	0.0681
5G NR n5		64QAM			256QAM					
BW (MHz)	Frequency Range (MHz)	Emission Designator (99%OBW)	Frequency Tolerance (ppm)	Maximum ERP(W)	Emission Designator (99%OBW)	Frequency Tolerance (ppm)	Maximum ERP(W)	Emission Designator (99%OBW)	Frequency Tolerance (ppm)	Maximum ERP(W)
5	826.5 ~ 846.5	4M49W7D	-	0.0817	4M48W7D	-	0.0817	4M48W7D	-	0.0817
10	829.0 ~ 844.0	9M27W7D	-	0.0757	9M27W7D	-	0.0757	9M27W7D	-	0.0757
15	831.5 ~ 841.5	14M1W7D	-	0.0714	14M1W7D	-	0.0714	14M1W7D	-	0.0714
20	834.0 ~ 839.0	18M9W7D	-	0.0681	18M9W7D	-	0.0681	18M9W7D	-	0.0681



5G NR n7		PI/2 BPSK			QPSK			16QAM		
BW (MHz)	Frequency Range (MHz)	Emission Designator (99%OBW)	Frequency Tolerance (ppm)	Maximum EIRP(W)	Emission Designator (99%OBW)	Frequency Tolerance (ppm)	Maximum EIRP(W)	Emission Designator (99%OBW)	Frequency Tolerance (ppm)	Maximum EIRP(W)
5	2502.5 ~ 2567.5	4M46F9W	-	0.4426	4M49G7D	-	0.4426	4M52W7D	-	0.3420
10	2505.0 ~ 2565.0	8M90F9W	-	0.4406	9M28G7D	-	0.4406	9M27W7D	-	0.3334
15	2507.5 ~ 2562.5	13M5F9W	-	0.4385	14M1G7D	-	0.4385	14M2W7D	-	0.3428
20	2510.0 ~ 2560.0	18M0F9W	0.0037	0.4305	18M9G7D	-	0.4305	19M0W7D	-	0.3243
5G NR n7		64QAM				256QAM				
BW (MHz)	Frequency Range (MHz)	Emission Designator (99%OBW)	Frequency Tolerance (ppm)	Maximum EIRP(W)	Emission Designator (99%OBW)	Frequency Tolerance (ppm)	Maximum EIRP(W)			
5	2502.5 ~ 2567.5	4M48W7D	-	0.3420	4M50W7D	-	0.3420			
10	2505.0 ~ 2565.0	9M27W7D	-	0.3334	9M29W7D	-	0.3334			
15	2507.5 ~ 2562.5	14M2W7D	-	0.3428	14M2W7D	-	0.3428			
20	2510.0 ~ 2560.0	19M0W7D	-	0.3243	19M0W7D	-	0.3243			

5G NR n38		PI/2 BPSK			QPSK			16QAM		
BW (MHz)	Frequency Range (MHz)	Emission Designator (99%OBW)	Frequency Tolerance (ppm)	Maximum EIRP(W)	Emission Designator (99%OBW)	Frequency Tolerance (ppm)	Maximum EIRP(W)	Emission Designator (99%OBW)	Frequency Tolerance (ppm)	Maximum EIRP(W)
20	2580.0~2610.0	-	-	0.2099	-	-	0.2099	-	-	0.1648
30	2585.0~2605.0	-	-	0.2148	-	-	0.2148	-	-	0.1663
40	2590.0~2600.0	-	-	0.2168	-	-	0.2168	-	-	0.1698
5G NR n38		64QAM				256QAM				
BW (MHz)	Frequency Range (MHz)	Emission Designator (99%OBW)	Frequency Tolerance (ppm)	Maximum EIRP(W)	Emission Designator (99%OBW)	Frequency Tolerance (ppm)	Maximum EIRP(W)			
20	2580.0~2610.0	-	-	0.1648	-	-	0.1648			
30	2585.0~2605.0	-	-	0.1663	-	-	0.1663			
40	2590.0~2600.0	-	-	0.1698	-	-	0.1698			



5G NR n41		PI/2 BPSK			QPSK			16QAM		
BW (MHz)	Frequency Range (MHz)	Emission Designator (99%OBW)	Frequency Tolerance (ppm)	Maximum EIRP(W)	Emission Designator (99%OBW)	Frequency Tolerance (ppm)	Maximum EIRP(W)	Emission Designator (99%OBW)	Frequency Tolerance (ppm)	Maximum EIRP(W)
20	2506.02 ~ 2679.99	17M9F9W	0.0023	0.3524	18M2G7D	-	0.3524	18M3W7D	-	0.2812
30	2511.00 ~ 2674.98	26M8F9W	-	0.3639	27M8G7D	-	0.3639	27M9W7D	-	0.2838
40	2516.01 ~ 2670.00	35M9F9W	-	0.3631	38M1G7D	-	0.3631	37M9W7D	-	0.2838
50	2521.02 ~ 2664.99	45M8F9W	-	0.3252	47M6G7D	-	0.3532	47M5W7D	-	0.2983
60	2526.00 ~ 2659.98	57M9F9W	-	0.3499	57M8G7D	-	0.3499	57M9W7D	-	0.2799
80	2536.02 ~ 2649.99	77M1F9W	-	0.3327	77M4G7D	-	0.3327	77M1W7D	-	0.2612
90	2541.00 ~ 2644.98	86M6F9W	-	0.3388	87M3G7D	-	0.3388	87M2W7D	-	0.2667
100	2546.01 ~ 2640.00	96M2F9W	-	0.3342	97M2G7D	-	0.3342	97M1W7D	-	0.2564
5G NR n41		64QAM			256QAM					
BW (MHz)	Frequency Range (MHz)	Emission Designator (99%OBW)	Frequency Tolerance (ppm)	Maximum EIRP(W)	Emission Designator (99%OBW)	Frequency Tolerance (ppm)	Maximum EIRP(W)	Emission Designator (99%OBW)	Frequency Tolerance (ppm)	Maximum EIRP(W)
20	2506.02 ~ 2679.99	18M2W7D	-	0.2812	18M2W7D	-	0.2812			
30	2511.00 ~ 2674.98	27M8W7D	-	0.2838	27M9W7D	-	0.2838			
40	2516.01 ~ 2670.00	37M9W7D	-	0.2838	38M1W7D	-	0.2838			
50	2521.02 ~ 2664.99	47M6W7D	-	0.2983	47M5W7D	-	0.2983			
60	2526.00 ~ 2659.98	57M9W7D	-	0.2799	57M9W7D	-	0.2799			
80	2536.02 ~ 2649.99	77M4W7D	-	0.2612	77M3W7D	-	0.2612			
90	2541.00 ~ 2644.98	87M2W7D	-	0.2667	87M1W7D	-	0.2667			
100	2546.01 ~ 2640.00	97M3W7D	-	0.2564	97M5W7D	-	0.2564			



5G NR n66		PI/2 BPSK			QPSK			16QAM		
BW (MHz)	Frequency Range (MHz)	Emission Designator (99%OBW)	Frequency Tolerance (ppm)	Maximum EIRP(W)	Emission Designator (99%OBW)	Frequency Tolerance (ppm)	Maximum EIRP(W)	Emission Designator (99%OBW)	Frequency Tolerance (ppm)	Maximum EIRP(W)
5	1712.5 ~ 1777.5	4M46F9W	-	0.4603	4M49G7D	-	0.4603	4M50W7D	-	0.3443
10	1715.0 ~ 1775.0	8M91F9W	-	0.4508	9M29G7D	-	0.4508	9M27W7D	-	0.3532
15	1717.5 ~ 1772.5	13M5F9W	-	0.4315	14M2G7D	-	0.4315	14M2W7D	-	0.3170
20	1720.0 ~ 1770.0	18M0F9W	0.0034	0.4285	19M0G7D	-	0.4285	19M0W7D	-	0.3214
30	1725.0~1765.0	28M6F9W	-	0.4416	28M6G7D	-	0.4416	28M6W7D	-	0.3155
40	1730.0~1760.0	38M8F9W	-	0.4325	38M8G7D	-	0.4325	38M7W7D	-	0.2944
5G NR n66		64QAM			256QAM					
BW (MHz)	Frequency Range (MHz)	Emission Designator (99%OBW)	Frequency Tolerance (ppm)	Maximum EIRP(W)	Emission Designator (99%OBW)	Frequency Tolerance (ppm)	Maximum EIRP(W)			
5	1712.5 ~ 1777.5	4M50W7D	-	0.3443	4M48W7D	-	0.3443			
10	1715.0 ~ 1775.0	9M28W7D	-	0.3532	9M28W7D	-	0.3532			
15	1717.5 ~ 1772.5	14M2W7D	-	0.3170	14M2W7D	-	0.3170			
20	1720.0 ~ 1770.0	19M0W7D	-	0.3214	19M0W7D	-	0.3214			
30	1725.0~1765.0	28M6W7D	-	0.3155	28M7W7D	-	0.3155			
40	1730.0~1760.0	38M8W7D	-	0.2944	38M8W7D	-	0.2944			



5G NR n71		PI/2 BPSK			QPSK			16QAM		
BW (MHz)	Frequency Range (MHz)	Emission Designator (99%OBW)	Frequency Tolerance (ppm)	Maximum ERP(W)	Emission Designator (99%OBW)	Frequency Tolerance (ppm)	Maximum ERP(W)	Emission Designator (99%OBW)	Frequency Tolerance (ppm)	Maximum ERP(W)
5	665.5 ~ 695.5	4M47F9W	-	0.1489	4M47G7D	-	0.1489	4M50W7D	-	0.1172
10	668.0 ~ 693.0	8M89F9W	-	0.1496	9M25G7D	-	0.1496	9M24W7D	-	0.1199
15	670.5 ~ 690.5	13M4F9W	-	0.1442	14M1G7D	-	0.1442	14M1W7D	-	0.1161
20	673.0 ~ 688.0	17M8F9W	0.0053	0.1500	18M9G7D	-	0.1500	18M9W7D	-	0.1349
5G NR n71		64QAM			256QAM					
BW (MHz)	Frequency Range (MHz)	Emission Designator (99%OBW)	Frequency Tolerance (ppm)	Maximum ERP(W)	Emission Designator (99%OBW)	Frequency Tolerance (ppm)	Maximum ERP(W)	Emission Designator (99%OBW)	Frequency Tolerance (ppm)	Maximum ERP(W)
5	665.5 ~ 695.5	4M47W7D	-	0.1172	4M49W7D	-	0.1172			
10	668.0 ~ 693.0	9M23W7D	-	0.1199	9M28W7D	-	0.1199			
15	670.5 ~ 690.5	14M1W7D	-	0.1161	14M1W7D	-	0.1161			
20	673.0 ~ 688.0	18M8W7D	-	0.1349	18M8W7D	-	0.1349			



1.5 Testing Location

Test Site	Sporton International Inc. EMC & Wireless Communications Laboratory
Test Site Location	No.52, Huaya 1st Rd., Guishan Dist., Taoyuan City 333, Taiwan (R.O.C.) TEL: +886-3-327-3456 FAX: +886-3-328-4978
Test Site No.	Sporton Site No.
	TH03-HY
Test Engineer	Ivy Yeh
Temperature (°C)	20~24
Relative Humidity (%)	50~58

Test Site	Sporton International Inc. Wensan Laboratory
Test Site Location	No.58, Aly. 75, Ln. 564, Wenhua 3rd, Rd., Guishan Dist., Taoyuan City 333010, Taiwan (R.O.C.) TEL: +886-3-327-0868 FAX: +886-3-327-0855
Test Site No.	Sporton Site No.
	03CH13-HY (TAF Code: 3786)
Test Engineer	Rain Lee, Jacky Hong and Peter Liao
Temperature (°C)	20~25
Relative Humidity (%)	50~60
Remark	The Radiated Spurious Emission test item subcontracted to Sporton International Inc. Wensan Laboratory.

Note: The test site complies with ANSI C63.4 2014 requirement.

FCC Designation No.: TW1190 and TW3786

1.6 Applicable Standards

According to the specifications of the manufacturer, the EUT must comply with the requirements of the following standards:

- ♦ ANSI C63.26-2015
- ♦ ANSI / TIA-603-E
- ♦ FCC 47 CFR Part 2, 22(H), 24(E), 27
- ♦ FCC KDB 971168 D01 Power Meas. License Digital Systems v03r01
- ♦ FCC KDB 412172 D01 Determining ERP and EIRP v01r01
- ♦ FCC KDB 414788 D01 Radiated Test Site v01r01.

Remark:

1. All test items were verified and recorded according to the standards and without any deviation during the test.
2. This EUT has also been tested and complied with the requirements of FCC Part 15, Subpart B, recorded in a separate test report.
3. The TAF code is not including all the FCC KDB listed without accreditation.



2 Test Configuration of Equipment Under Test

2.1 Test Mode

Antenna port conducted and radiated test items listed below are performed according to KDB 971168 D01 Power Meas. License Digital Systems v03r01 with maximum output power.

For radiated measurement, the measured emission level of the EUT was maximized by rotating the EUT on a turntable, adjusting the orientation of the EUT and EUT antenna in three orthogonal axis (X: flat, Y: portrait, Z: landscape) and Accessory (Adapter or Earphone), and adjusting the measurement antenna orientation, following C63.26 exploratory test procedures and find X Plane with Adapter for 5G NR n66, ENDC 7A-n2A, 7A-n66A and 66A-n7A; Y Plane with Adapter for 5G NR n5 and n41; Z Plane with Adapter for 5G NR n2, n7, n38, n71 and ENDC 7A-n5A as worst plane.

Test Items	NR Band	Bandwidth (MHz)											Modulation					RB #			Test Channel						
		5	10	15	20	30	40	50	60	80	90	100	PI/2 BPSK	QPSK	16QAM	64QAM	256QAM	1	Half	Full	L	M	H				
Max. Output Power	n2	v	v	v	v	-	-	-	-	-	-	-	v	v	v	v	v	v	v	v	v	v	v	v	v	v	v
	n5	v	v	v	v	-	-	-	-	-	-	-	v	v	v	v	v	v	v	v	v	v	v	v	v	v	v
	n7	v	v	v	v	-	-	-	-	-	-	-	v	v	v	v	v	v	v	v	v	v	v	v	v	v	v
	n38	-	-	-	v	v	v	-	-	-	-	-	v	v	v	v	v	v	v	v	v	v	v	v	v	v	v
	n41	-	-	-	v	v	v	v	v	v	v	v	v	v	v	v	v	v	v	v	v	v	v	v	v	v	v
	n66	v	v	v	v	v	v	-	-	-	-	-	v	v	v	v	v	v	v	v	v	v	v	v	v	v	v
	n71	v	v	v	v	-	-	-	-	-	-	-	v	v	v	v	v	v	v	v	v	v	v	v	v	v	v
Peak-to-Average Ratio	n2				v	-	-	-	-	-	-	v	v	v	v	v				v		v					
	n5				v	-	-	-	-	-	-	v	v	v	v	v				v		v					
	n7				v	-	-	-	-	-	-	v	v	v	v	v				v		v					
	n38	Covered by n41																									
	n41	-	-	-	v								v	v	v	v	v				v		v				
	n66				v			-	-	-	-	-	v	v	v	v	v				v		v				
	n71				v	-	-	-	-	-	-	-	v	v	v	v	v				v		v				
26dB and 99% Bandwidth	n2	v	v	v	v	-	-	-	-	-	-	v	v	v	v	v				v		v					
	n5	v	v	v	v	-	-	-	-	-	-	v	v	v	v	v				v		v					
	n7	v	v	v	v	-	-	-	-	-	-	v	v	v	v	v				v		v					
	n38	Covered by n41																									
	n41	-	-	-	v	v	v	v	v	v	v	v	v	v	v	v	v				v		v				
	n66	v	v	v	v	v	v	-	-	-	-	-	v	v	v	v	v				v		v				
	n71	v	v	v	v	-	-	-	-	-	-	-	v	v	v	v	v				v		v				



Test Items	NR Band	Bandwidth (MHz)											Modulation					RB #			Test Channel		
		5	10	15	20	30	40	50	60	80	90	100	PI/2 BPSK	QPSK	16QAM	64QAM	256QAM	1	Half	Full	L	M	H
Conducted Band Edge	n2	v	v	v	v	-	-	-	-	-	-	-	v	v	v	v	v	v		v	v		v
	n5	v	v	v	v	-	-	-	-	-	-	-	v	v	v	v	v	v		v	v		v
	n7	v	v	v	v	-	-	-	-	-	-	-	v	v	v	v	v	v		v	v		v
	n38	Covered by n41																					
	n41	-	-	-	v	v	v	v	v	v	v	v	v	v	v	v	v	v		v	v		v
	n66	v	v	v	v	v	v	-	-	-	-	-	v	v	v	v	v	v		v	v		v
	n71	v	v	v	v	-	-	-	-	-	-	-	v	v	v	v	v	v		v	v		v
Conducted Spurious Emission	n2	v				-	-	-	-	-	-		v				v			v	v	v	
	n5	v				-	-	-	-	-	-		v				v			v	v	v	
	n7	v				-	-	-	-	-	-		v				v			v	v	v	
	n38	Covered by n41																					
	n41	-	-	-	v									v				v			v	v	v
	n66	v						-	-	-	-	-		v				v			v	v	v
	n71	v				-	-	-	-	-	-	-		v				v			v	v	v
Frequency Stability	n2				v	-	-	-	-	-	-	v							v		v		
	n5				v	-	-	-	-	-	-	v							v		v		
	n7				v	-	-	-	-	-	-	v							v		v		
	n38	Covered by n41																					
	n41	-	-	-	v								v							v		v	
	n66				v			-	-	-	-	-	v							v		v	
	n71				v	-	-	-	-	-	-	-	v							v		v	
E.R.P / E.I.R.P	n2	v	v	v	v	-	-	-	-	-	-	v	v	v	v	v	Max Power						
	n5	v	v	v	v	-	-	-	-	-	-	v	v	v	v	v							
	n7	v	v	v	v	-	-	-	-	-	-	v	v	v	v	v							
	n38	-	-	-	v	v	v	-	-	-	-	v	v	v	v	v							
	n41	-	-	-	v	v	v	v	v	v	v	v	v	v	v	v							
	n66	v	v	v	v	v	v	-	-	-	-	v	v	v	v	v							
	n71	v	v	v	v	-	-	-	-	-	-	v	v	v	v	v							



Test Items	NR Band	Bandwidth (MHz)											Modulation					RB #			Test Channel		
		5	10	15	20	30	40	50	60	80	90	100	PI/2 BPSK	QPSK	16QAM	64QAM	256QAM	1	Half	Full	L	M	H
Radiated Spurious Emission	n2	Worst Case																v	v	v			
	n5	Worst Case																v	v	v			
	n7	Worst Case																v	v	v			
	n38	Worst Case																v	v	v			
	n41	Worst Case																v	v	v			
	n66	Worst Case																v	v	v			
	n71	Worst Case																v	v	v			
Remark	<ol style="list-style-type: none"> The mark "v " means that this configuration is chosen for testing The mark "- " means that this bandwidth is not supported. The device is investigated from 30MHz to 10 times of fundamental signal for radiated spurious emission test under different RB size/offset and modulations in exploratory test. Subsequently, only the worst case emissions are reported. Test combination is EN-DC 7A_n2A, EN-DC 7A_n5A, EN-DC 66A_n7A and EN-DC 7A_n66A. For radiated measurement, pre-scanned in two modes, DFT-s OFDM and CP OFDM. The worst cases (DFT-s OFDM) were recorded in this report, and the worst modes of FR1 and LTE for simultaneous transmission were verified and compliant. All the radiated test cases were performed with Battery 1X and Sample 2. Wider operating range bandwidth covers narrower one when the power is higher or the same. 																						

2.2 Connection Diagram of Test System

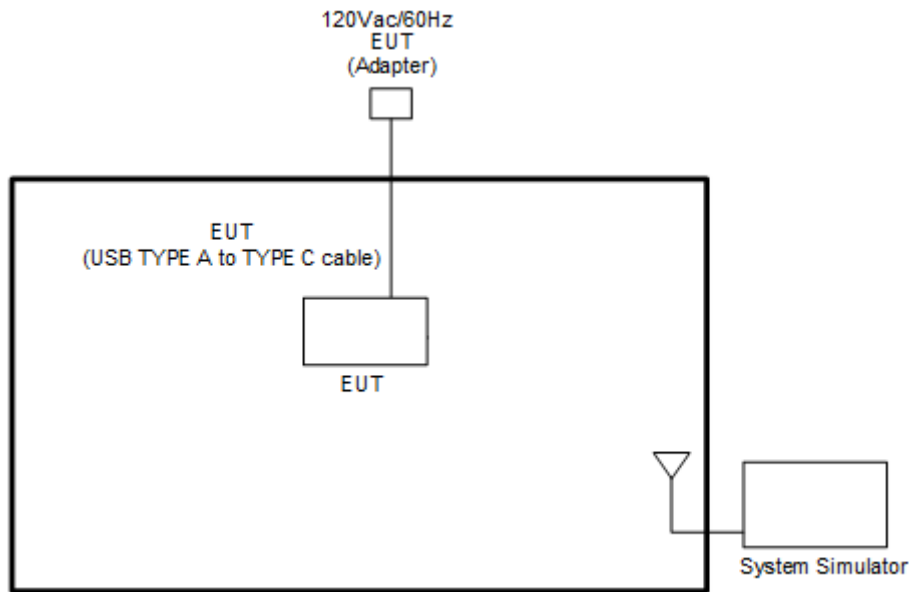

2.3 Support Unit used in test configuration and system

Item	Equipment	Brand Name	Model No.	FCC ID	Data Cable	Power Cord
1.	5G Wireless Test Platform	Anritsu	MT8000A	N/A	N/A	Unshielded, 1.8 m
2.	System Simulator	Anritsu	MT8821C	N/A	N/A	Unshielded, 1.8 m

2.4 Measurement Results Explanation Example

For all conducted test items:

The offset level is set in the spectrum analyzer to compensate the RF cable loss and attenuator factor between EUT conducted output port and spectrum analyzer. With the offset compensation, the spectrum analyzer reading level is exactly the EUT RF output level.

The spectrum analyzer offset is derived from RF cable loss and attenuator factor.

$$\text{Offset} = \text{RF cable loss} + \text{attenuator factor}.$$

Following shows an offset computation example with cable loss 4.2 dB and 10dB attenuator.

Example :

$$\begin{aligned} \text{Offset(dB)} &= \text{RF cable loss(dB)} + \text{attenuator factor(dB)}. \\ &= 4.2 + 10 = 14.2 \text{ (dB)} \end{aligned}$$



2.5 Frequency List of Low/Middle/High Channels

5G NR n2 Channel and Frequency List				
BW [MHz]	Channel/Frequency(MHz)	Lowest	Middle	Highest
20	Channel	372000	376000	380000
	Frequency	1860	1880	1900
15	Channel	371500	376000	380500
	Frequency	1857.5	1880	1902.5
10	Channel	371000	376000	381000
	Frequency	1855	1880	1905
5	Channel	370500	376000	381500
	Frequency	1852.5	1880	1907.5

5G NR n5 Channel and Frequency List				
BW [MHz]	Channel/Frequency(MHz)	Lowest	Middle	Highest
20	Channel	166800	167300	167800
	Frequency	834	836.5	839
15	Channel	166300	167300	168300
	Frequency	831.5	836.5	841.5
10	Channel	165800	167300	168800
	Frequency	829	836.5	844
5	Channel	165300	167300	169300
	Frequency	826.5	836.5	846.5



5G NR n7 Channel and Frequency List				
BW [MHz]	Channel/Frequency(MHz)	Lowest	Middle	Highest
20	Channel	502000	507000	512000
	Frequency	2510	2535	2560
15	Channel	501500	507000	512500
	Frequency	2507.5	2535	2562.5
10	Channel	501000	507000	513000
	Frequency	2505	2535	2565
5	Channel	500500	507000	513500
	Frequency	2502.5	2535	2567.5

5G NR n38 Channel and Frequency List				
BW [MHz]	Channel/Frequency(MHz)	Lowest	Middle	Highest
40	Channel	517000	519000	521000
	Frequency	2590	2595	2600
30	Channel	518000	519000	520000
	Frequency	2585	2595	2605
20	Channel	516000	519000	522000
	Frequency	2580	2595	2610



5G NR n41 Channel and Frequency List				
BW [MHz]	Channel/Frequency(MHz)	Lowest	Middle	Highest
100	Channel	509202	518598	528000
	Frequency	2546.01	2592.99	2640
90	Channel	508200	518598	528996
	Frequency	2541	2592.99	2644.98
80	Channel	507204	518598	529998
	Frequency	2536.02	2592.99	2649.99
60	Channel	505200	518598	531996
	Frequency	2526	2592.99	2659.98
50	Channel	504204	518598	532998
	Frequency	2521.02	2592.99	2664.99
40	Channel	503202	518598	534000
	Frequency	2516.01	2592.99	2670
30	Channel	502200	518598	534996
	Frequency	2511	2592.99	2674.98
20	Channel	501204	518598	535998
	Frequency	2506.02	2592.99	2679.99



5G NR Band n66 Channel and Frequency List				
BW [MHz]	Channel/Frequency(MHz)	Lowest	Middle	Highest
40	Channel	346000	349000	352000
	Frequency	1730	1745	1760
30	Channel	345000	349000	353000
	Frequency	1725	1745	1765
20	Channel	344000	349000	354000
	Frequency	1720	1745	1770
15	Channel	343500	349000	354500
	Frequency	1717.5	1745	1772.5
10	Channel	343000	349000	355000
	Frequency	1715	1745	1775
5	Channel	342500	349000	355500
	Frequency	1712.5	1745	1777.5

5G NR Band n71 Channel and Frequency List				
BW [MHz]	Channel/Frequency(MHz)	Lowest	Middle	Highest
20	Channel	134600	136100	137600
	Frequency	673	680.5	688
15	Channel	134100	136100	138100
	Frequency	670.5	680.5	690.5
10	Channel	133600	136100	138600
	Frequency	668	680.5	693
5	Channel	133100	136100	139100
	Frequency	665.5	680.5	695.5

3 Conducted Test Items

3.1 Measuring Instruments

See list of measuring instruments of this test report.

3.1.1 Test Setup

3.1.2 Conducted Output Power

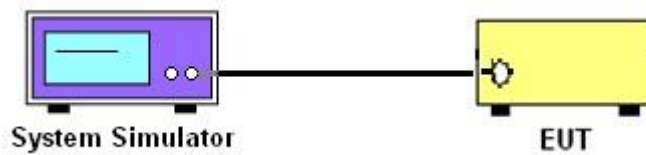

3.1.3 Peak-to-Average Ratio, Occupied Bandwidth ,Conducted Band-Edge and Conducted Spurious Emission

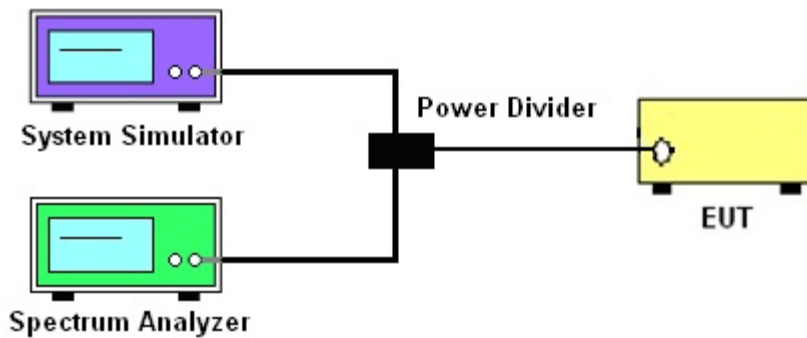

3.1.4 Frequency Stability



3.1.5 Test Result of Conducted Test

Please refer to Appendix A.



3.2 Conducted Output Power and ERP/EIRP

3.2.1 Description of the Conducted Output Power Measurement and ERP/EIRP Measurement

A system simulator was used to establish communication with the EUT. Its parameters were set to force the EUT transmitting at maximum output power. The measured power in the radio frequency on the transmitter output terminals shall be reported.

The ERP of mobile transmitters must not exceed 7 Watts for 5G NR n5

The ERP of mobile transmitters must not exceed 3 Watts for 5G NR n71

The EIRP of mobile transmitters must not exceed 2 Watts for 5G NR n2 and n25 and n7 and n38 and n41.

The EIRP of mobile transmitters must not exceed 1 Watts for 5G NR n66

According to KDB 412172 D01 Power Approach,

$EIRP = P_T + G_T - L_C$, $ERP = EIRP - 2.15$, where

P_T = transmitter output power in dBm

G_T = gain of the transmitting antenna in dBi

L_C = signal attenuation in the connecting cable between the transmitter and antenna in dB

3.2.2 Test Procedures

1. The transmitter output port was connected to the system simulator.
2. Set EUT at maximum power through the system simulator.
3. Select lowest, middle, and highest channels for each band and different modulation.
4. Measure and record the power level from the system simulator.



3.3 Peak-to-Average Ratio

3.3.1 Description of the PAR Measurement

Power Complementary Cumulative Distribution Function (CCDF) curves provide a means for characterizing the power peaks of a digitally modulated signal on a statistical basis. A CCDF curve depicts the probability of the peak signal amplitude exceeding the average power level. Most contemporary measurement instrumentation include the capability to produce CCDF curves for an input signal provided that the instrument's resolution bandwidth can be set wide enough to accommodate the entire input signal bandwidth. In measuring transmissions in this band using an average power technique, the peak-to-average ratio (PAR) of the transmission may not exceed 13 dB.

3.3.2 Test Procedures

The testing follows ANSI C63.26-2015 Section 5.2.6

1. The EUT was connected to spectrum and system simulator via a power divider.
2. Set the CCDF (Complementary Cumulative Distribution Function) option in spectrum analyzer.
3. The highest RF powers were measured and recorded the maximum PAPR level associated with a probability of 0.1 %.
4. Record the deviation as Peak to Average Ratio.



3.4 Occupied Bandwidth

3.4.1 Description of Occupied Bandwidth Measurement

The occupied bandwidth is the width of a frequency band such that, below the lower and above the upper frequency limits, the mean powers emitted are each equal to a specified percentage 0.5% of the total mean transmitted power.

The 26 dB emission bandwidth is defined as the frequency range between two points, one above and one below the carrier frequency, at which the spectral density of the emission is attenuated 26 dB below the maximum in-band spectral density of the modulated signal. Spectral density (power per unit bandwidth) is to be measured with a detector of resolution bandwidth equal to approximately 1.0% of the emission bandwidth.

3.4.2 Test Procedures

The testing follows ANSI C63.26-2015 Section 5.4.3 (26dB) and Section 5.4.4 (99OB)

1. The EUT was connected to spectrum analyzer and system simulator via a power divider.
2. The spectrum analyzer center frequency is set to the nominal EUT channel center frequency. The span range for the spectrum analyzer shall be between two and five times the anticipated OBW.
3. The nominal resolution bandwidth (RBW) shall be in the range of 1 to 5 % of the anticipated OBW, and the VBW shall be at least 3 times the RBW.
4. Set the detection mode to peak, and the trace mode to max hold.
5. Determine the reference value: Set the EUT to transmit a modulated signal. Allow the trace to stabilize. Set the spectrum analyzer marker to the highest level of the displayed trace.
(this is the reference value)
6. Determine the “-26 dB down amplitude” as equal to (Reference Value – X).
7. Place two markers, one at the lowest and the other at the highest frequency of the envelope of the spectral display such that each marker is at or slightly below the “-X dB down amplitude” determined in step 6. If a marker is below this “-X dB down amplitude” value it shall be placed as close as possible to this value. The OBW is the positive frequency difference between the two markers.
8. Use the 99 % power bandwidth function of the spectrum analyzer and report the measured bandwidth.



3.5 Conducted Band Edge

3.5.1 Description of Conducted Band Edge Measurement

22.917(a)

For operations in the 824 – 849 MHz band, the FCC limit is $43 + 10\log_{10}(P[\text{Watts}])$ dB below the transmitter power $P(\text{Watts})$ in a 100kHz bandwidth. However, in the 1MHz bands immediately outside and adjacent to the licensee's frequency block, a resolution bandwidth of at least one percent of the emission bandwidth of the fundamental emission of the transmitter may be employed.

24.238 (a)

For operations in the 1850-1910 and 1930-1990 MHz band, the FCC limit is $43 + 10\log_{10}(P[\text{Watts}])$ dB below the transmitter power $P(\text{Watts})$ in a 1MHz bandwidth. However, in the 1 MHz bands immediately outside and adjacent to the frequency block a resolution bandwidth of at least one percent of the emission bandwidth of the fundamental emission of the transmitter may be employed.

27.53 (g)

For operations in the 600MHz band and 698-746 MHz band, the FCC limit is $43 + 10\log_{10}(P[\text{Watts}])$ dB below the transmitter power $P(\text{Watts})$ in a 100 kHz bandwidth. However, in the 100 kilohertz bands immediately outside and adjacent to a licensee's frequency block, a resolution bandwidth of at least 30 kHz may be employed.

27.53 (h)

For operations in the 1710 – 1755 MHz band, 1755-1780 MHz, the FCC limit is $43 + 10\log_{10}(P[\text{Watts}])$ dB below the transmitter power $P(\text{Watts})$ in a 1 MHz bandwidth. However, in the 1MHz bands immediately outside and adjacent to the licensee's frequency block, a resolution bandwidth of at least one percent of the emission bandwidth of the fundamental emission of the transmitter may be employed.

**27.53(m)(4)**

For mobile digital stations, the attenuation factor shall be not less than $40 + 10 \log (P)$ dB on all frequencies between the channel edge and 5 megahertz from the channel edge, $43 + 10 \log (P)$ dB on all frequencies between 5 megahertz and X megahertz from the channel edge, and $55 + 10 \log (P)$ dB on all frequencies more than X megahertz from the channel edge, where X is the greater of 6 megahertz or the actual emission bandwidth as defined in paragraph (m)(6) of this section. In addition, the attenuation factor shall not be less than $43 + 10 \log (P)$ dB on all frequencies between 2490.5 MHz and 2496 MHz and $55 + 10 \log (P)$ dB at or below 2490.5 MHz. Mobile Satellite Service licensees operating on frequencies below 2495 MHz may also submit a documented interference complaint against BRS licensees operating on channel BRS Channel 1 on the same terms and conditions as adjacent channel BRS or EBS licensees.

3.5.2 Test Procedures

The testing follows FCC KDB 971168 D01 v03r01 Section 6.1.

1. The EUT was connected to spectrum analyzer and system simulator via a power divider.
2. The band edges of low and high channels for the highest RF powers were measured.
3. Set RBW \geq 1% EBW in the 1MHz band immediately outside and adjacent to the band edge.
4. Beyond the 1 MHz band from the band edge, RBW=1MHz was used.
5. Set spectrum analyzer with RMS detector.
6. The RF fundamental frequency should be excluded against the limit line in the operating frequency band.
7. Checked that all the results comply with the emission limit line.

The limit line is derived from $43 + 10\log(P)$ dB below the transmitter power P(Watts)

For 5G NR n7

The other 40 dB, and 55 dB have additionally applied same calculation above.



3.6 Conducted Spurious Emission

3.6.1 Description of Conducted Spurious Emission Measurement

The power of any emission outside of the authorized operating frequency ranges must be lower than the transmitter power (P) by a factor of at least $43 + 10 \log (P)$ dB.

For 5G NR n7, n38, n41

The power of any emission outside of the authorized operating frequency ranges must be lower than the transmitter power (P) by a factor of at least $55 + 10 \log (P)$ dB.

It is measured by means of a calibrated spectrum analyzer and scanned from 30 MHz up to a frequency including its 10th harmonic.

3.6.2 Test Procedures

The testing follows FCC KDB 971168 D01 v03r01 Section 6.1.

1. The EUT was connected to spectrum analyzer and system simulator via a power divider.
2. The RF output of EUT was connected to the spectrum analyzer by RF cable and attenuator.
The path loss was compensated to the results for each measurement.
3. The middle channel for the highest RF power within the transmitting frequency was measured.
4. The conducted spurious emission for the whole frequency range was taken.
5. Make the measurement with the spectrum analyzer's RBW = 1MHz, VBW = 3MHz.
6. Set spectrum analyzer with RMS detector.
7. Taking the record of maximum spurious emission.
8. The RF fundamental frequency should be excluded against the limit line in the operating frequency band.
9. The limit line is derived from $43 + 10\log(P)$ dB below the transmitter power P(Watts)
For 5G NR n7, n38, n41
The limit line is derived from $55 + 10\log(P)$ dB below the transmitter power P(Watts)



3.7 Frequency Stability

3.7.1 Description of Frequency Stability Measurement

22.355

The frequency stability shall be measured by variation of ambient temperature and variation of primary supply voltage to ensure that the fundamental emission stays within the authorized frequency block. The frequency stability of the transmitter shall be maintained within $\pm 0.00025\%$ ($\pm 2.5\text{ppm}$) of the center frequency.

24.235 & 27.54

The frequency stability shall be sufficient to ensure that the fundamental emission stays within the authorized frequency block.

3.7.2 Test Procedures for Temperature Variation

The testing follows FCC KDB 971168 D01 v03r01 Section 9.0.

1. The EUT was set up in the thermal chamber and connected with the system simulator.
2. With power OFF, the temperature was decreased to -30°C and the EUT was stabilized before testing. Power was applied and the maximum change in frequency was recorded within one minute.
3. With power OFF, the temperature was raised in 10°C step up to 50°C . The EUT was stabilized at each step for at least half an hour. Power was applied and the maximum frequency change was recorded within one minute.

3.7.3 Test Procedures for Voltage Variation

The testing follows FCC KDB 971168 D01 v03r01 Section 9.0.

1. The EUT was placed in a temperature chamber at $20\pm 5^{\circ}\text{C}$ and connected with the system simulator.
2. The power supply voltage to the EUT was varied from 85% to 115% of the nominal value measured at the input to the EUT.
3. The variation in frequency was measured for the worst case.

4 Radiated Test Items

4.1 Measuring Instruments

See list of measuring instruments of this test report.

4.1.1 Test Setup

For radiated emissions below 30MHz

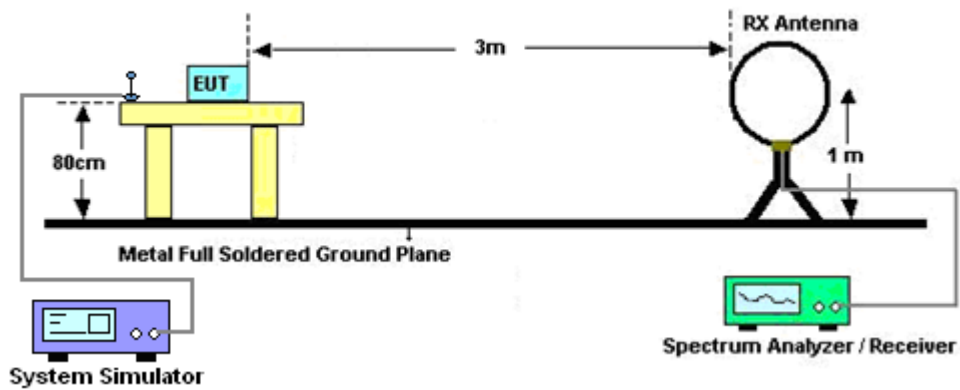

For radiated test from 30MHz to 1GHz

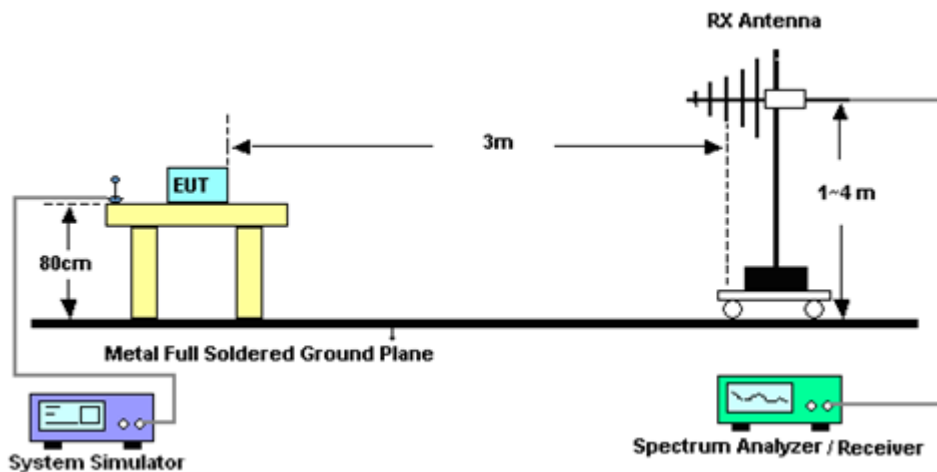

For radiated test from 1GHz to 18GHz

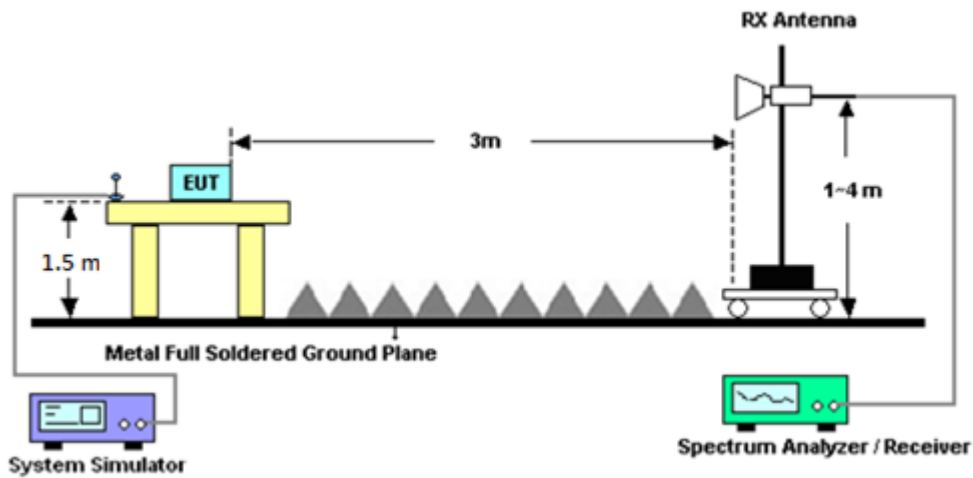

For radiated test above 18GHz

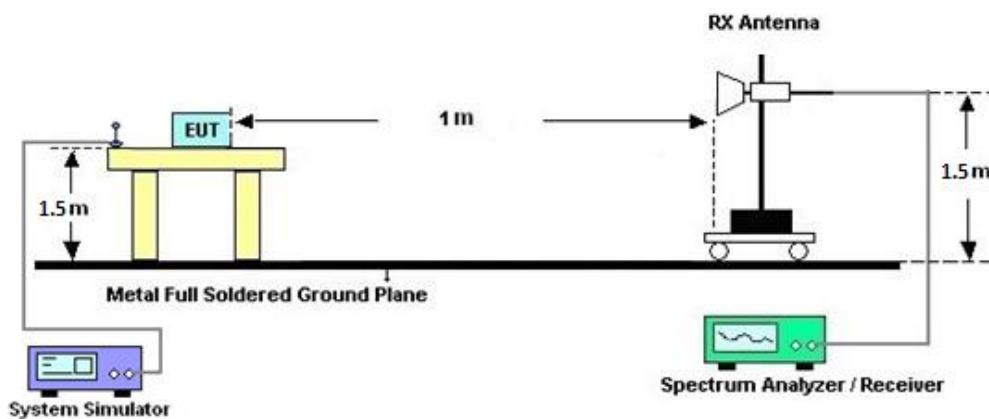

4.1.2 Test Result of Radiated Test

Please refer to Appendix B.

Note:

The low frequency, which started from 9 kHz to 30MHz, was pre-scanned and the result which was 20dB lower than the limit line was not reported.

There is adequate comparison measurement of both open-field test site and alternative test site - semi-Anechoic chamber according to 414788 D01 Radiated Test Site v01r01, and the result came out very similar.



4.2 Radiated Spurious Emission Measurement

4.2.1 Description of Radiated Spurious Emission Measurement

The radiated spurious emission was measured by substitution method according to ANSI / TIA-603-E. The power of any emission outside of the authorized operating frequency ranges must be attenuated below the transmitter power (P) by a factor of at least $43 + 10 \log (P)$ dB.

For 5G NR n7, n38, n41

The power of any emission outside of the authorized operating frequency ranges must be attenuated below the transmitter power (P) by a factor of at least $55 + 10 \log (P)$ dB.

The spectrum is scanned from 30 MHz up to a frequency including its 10th harmonic.

4.2.2 Test Procedures

The testing follows FCC KDB 971168 D01 v03r01 Section 7 and ANSI / TIA-603-E Section 2.2.12.

1. The EUT was placed on a turntable with 0.8 meter for frequency below 1GHz and 1.5 meter for frequency above 1GHz respectively above ground.
2. The EUT was set 3 meters from the receiving antenna, which was mounted on the antenna tower.
3. The table was rotated 360 degrees to determine the position of the highest spurious emission.
4. The height of the receiving antenna is varied between one meter and four meters to search the maximum spurious emission for both horizontal and vertical polarizations.
5. Make the measurement with the spectrum analyzer's RBW = 1MHz, VBW = 3MHz, taking the record of maximum spurious emission.
6. A horn antenna was substituted in place of the EUT and was driven by a signal generator.
7. Tune the output power of signal generator to the same emission level with EUT maximum spurious emission.
8. Taking the record of output power at antenna port.
9. Repeat step 7 to step 8 for another polarization.
10. The RF fundamental frequency should be excluded against the limit line in the operating frequency band.

The limit line is derived from $43 + 10\log(P)$ dB below the transmitter power P(Watts)

For 5G NR n7, n38, n41

The limit line is derived from $55 + 10\log(P)$ dB below the transmitter power P(Watts)

EIRP (dBm) = S.G. Power – Tx Cable Loss + Tx Antenna Gain

ERP (dBm) = EIRP - 2.15



5 List of Measuring Equipment

Instrument	Brand Name	Model No.	Serial No.	Characteristics	Calibration Date	Test Date	Due Date	Remark
Loop Antenna	Rohde & Schwarz	HFH2-Z2	100488	9kHz~30MHz	Sep. 07, 2021	May 05, 2022~ May 27, 2022	Sep. 06, 2022	Radiation (03CH13-HY)
Bilog Antenna	TESEQ	CBL 6111D&00800N1 D01N-06	40103 & 07	30MHz~1GHz	Apr. 24, 2022	May 05, 2022~ May 27, 2022	Apr. 23, 2023	Radiation (03CH13-HY)
Bilog Antenna	TESEQ	CBL 6111D&00802N1 D01N-06	54682 & AT-N0603	30MHz~1GHz	Sep. 09, 2021	May 05, 2022~ May 27, 2022	Sep. 08, 2022	Radiation (03CH13-HY)
Amplifier	Sonoma-Instrument	310 N	187282	9kHz~1GHz	Dec. 15, 2021	May 05, 2022~ May 27, 2022	Dec. 14, 2022	Radiation (03CH13-HY)
Horn Antenna	SCHWARZBECK	BBHA 9120 D	9120D-01620	1GHz~18GHz	Oct 25, 2021	May 05, 2022~ May 27, 2022	Oct 24, 2022	Radiation (03CH13-HY)
Horn Antenna	SCHWARZBECK	BBHA 9120 D	9120D-1241	1GHz~18GHz	Jul. 13, 2021	May 05, 2022~ May 27, 2022	Jul. 12, 2022	Radiation (03CH13-HY)
Preamplifier	MITEQ	AMF-7D-001018 00-30-10P	1590074	1GHz~18GHz	May 18, 2021	May 05, 2022~ May 16, 2022	May 17, 2022	Radiation (03CH13-HY)
Preamplifier	MITEQ	AMF-7D-001018 00-30-10P	1590074	1GHz~18GHz	May 17, 2022	May 17, 2022~ May 27, 2022	May 16, 2023	Radiation (03CH13-HY)
Preamplifier	Keysight	83017A	MY53270147	1GHz~26.5GHz	Oct. 26, 2021	May 05, 2022~ May 27, 2022	Oct. 25, 2022	Radiation (03CH13-HY)
SHF-EHF Horn Antenna	SCHWARZBECK	BBHA 9170	00993	18GHz~40GHz	Nov. 30, 2021	May 05, 2022~ May 27, 2022	Nov. 29, 2022	Radiation (03CH13-HY)
SHF-EHF Horn Antenna	SCHWARZBECK	BBHA 9170	00994	18GHz~40GHz	Nov. 04, 2021	May 05, 2022~ May 27, 2022	Nov. 03, 2022	Radiation (03CH13-HY)
Preamplifier	EMEC	EM18G40G	060801	18GHz~40GHz	Jun. 22, 2021	May 05, 2022~ May 27, 2022	Jun. 21, 2022	Radiation (03CH13-HY)
Spectrum Analyzer	Keysight	N9010A	MY55370526	10Hz~44GHz	Mar. 18, 2022	May 05, 2022~ May 27, 2022	Mar. 17, 2023	Radiation (03CH13-HY)
Signal Generator	Rohde & Schwarz	SMF100A	101107	100kHz~40GHz	Dec. 08, 2021	May 05, 2022~ May 27, 2022	Dec. 07, 2022	Radiation (03CH13-HY)
Filter	Wainwright	WHKX12-2700-3 000-18000-60SS	SN2	3GHz High Pass Filter	Jul. 12, 2021	May 05, 2022~ May 27, 2022	Jul. 11, 2022	Radiation (03CH13-HY)
RF Cable	HUBER + SUHNER	SUCOFLEX 104	MY9837/4PE	9kHz~30MHz	Mar. 10, 2022	May 05, 2022~ May 27, 2022	Mar. 09, 2023	Radiation (03CH13-HY)
RF Cable	HUBER + SUHNER	SUCOFLEX 126E	0030/126E	30MHz~18GHz	Feb. 09, 2022	May 05, 2022~ May 27, 2022	Feb. 08, 2023	Radiation (03CH13-HY)
RF Cable	HUBER + SUHNER	SUCOFLEX 104	804793/4	30MHz~18GHz	Feb. 09, 2022	May 05, 2022~ May 27, 2022	Feb. 08, 2023	Radiation (03CH13-HY)
RF Cable	HUBER + SUHNER	SUCOFLEX 104	MY24961/4	30MHz~18GHz	Feb. 09, 2022	May 05, 2022~ May 27, 2022	Feb. 08, 2023	Radiation (03CH13-HY)
RF Cable	HUBER + SUHNER	SUCOFLEX 102	804011/2, 804012/2	18GHz~40GHz	Jan. 04, 2022	May 05, 2022~ May 27, 2022	Jan. 03, 2023	Radiation (03CH13-HY)
Hygrometer	TECPEL	DTM-303B	TP200889	N/A	Sep. 30, 2021	May 05, 2022~ May 27, 2022	Sep. 29, 2022	Radiation (03CH13-HY)
Controller	EMEC	EM1000	N/A	Control Turn table & Ant Mast	N/A	May 05, 2022~ May 27, 2022	N/A	Radiation (03CH13-HY)



Instrument	Brand Name	Model No.	Serial No.	Characteristics	Calibration Date	Test Date	Due Date	Remark
Antenna Mast	EMEC	AM-BS-4500-B	N/A	1m~4m	N/A	May 05, 2022~ May 27, 2022	N/A	Radiation (03CH13-HY)
Turn Table	EMEC	TT2000	N/A	0~360 Degree	N/A	May 05, 2022~ May 27, 2022	N/A	Radiation (03CH13-HY)
Software	Audix	E3 6.2009-8-24	RK-000992	N/A	N/A	May 05, 2022~ May 27, 2022	N/A	Radiation (03CH13-HY)
Programmable Power Supply	GW Instek	PSS-2005	EL890001	50Hz~60Hz	Oct. 06, 2021	Apr. 15 2022 ~ May 31, 2022	Oct. 05, 2022	Conducted (TH03-HY)
Signal Analyzer	Rohde & Schwarz	FSV3044	101049	10Hz~44GHz	Aug. 31, 2021	Apr. 15 2022 ~ May 31, 2022	Aug. 30, 2022	Conducted (TH03-HY)
Temperature Chamber	ESPEC	SH-641	92013720	-40℃ ~90℃	Sep,09,2021	Apr. 15 2022 ~ May 31, 2022	Sep,08,2022	Conducted (TH03-HY)
Hygrometer	TECPEL	DTM-303B	TP200886	NA	Mar. 21,2022	Apr. 15 2022 ~ May 31, 2022	Mar. 20, 2023	Conducted (TH03-HY)
Base Station (Measure)	Anritsu	MT8821C	6261849015	LTE	Ocr. 06, 2021	Apr. 15 2022 ~ May 31, 2022	Oct. 05, 2022	Conducted (TH03-HY)
Base Station (Measure)	Anritsu	MT8000A	6261940327	FR1	Oct. 29, 2021	Apr. 15 2022 ~ May 31, 2022	Oct. 28, 2022	Conducted (TH03-HY)



6 Uncertainty of Evaluation

Uncertainty of Radiated Emission Measurement (30 MHz ~ 1000 MHz)

Measuring Uncertainty for a Level of Confidence of 95% ($U = 2Uc(y)$)	3.45 dB
---	---------

Uncertainty of Radiated Emission Measurement (1 GHz ~ 18 GHz)

Measuring Uncertainty for a Level of Confidence of 95% ($U = 2Uc(y)$)	3.73 dB
---	---------

Uncertainty of Radiated Emission Measurement (18 GHz ~ 40 GHz)

Measuring Uncertainty for a Level of Confidence of 95% ($U = 2Uc(y)$)	4.00 dB
---	---------



Appendix A. Test Results of Conducted Test

Conducted Output Power(Average power) and ERP/EIRP

NR n2 Maximum Average Power [dBm] (GT - LC = -0.07 dB)										
BW [MHz]	RB Size	RB Offset	Mod	Lowest	Middle	Highest	EIRP (dBm)	EIRP(W)		
5	1	1	PI/2 BPSK	23.85	24.37	24.58	24.51	0.2825		
5	1	23		23.66	24.41	24.40				
5	12	6		23.74	24.48	24.46				
5	1	0		23.29	23.96	24.00				
5	1	24		23.21	23.94	23.85				
5	25	0		23.24	23.99	24.02				
5	1	1	QPSK	23.74	24.58	24.50			23.32	0.2148
5	1	23		23.61	24.45	24.37				
5	12	6		23.67	24.36	24.43				
5	1	0		22.80	23.47	23.54				
5	1	24		22.72	23.51	23.50				
5	25	0		22.77	23.40	23.53				
5	1	1	16-QAM	22.63	23.34	23.39	23.32	0.2148		
5	1	1	64-QAM	21.46	22.19	22.30				
5	1	1	256-QAM	18.67	19.40	19.79				
Limit	EIRP < 2W			Result			Pass			

NR n2 Maximum Average Power [dBm] (GT - LC = -0.07 dB)										
BW [MHz]	RB Size	RB Offset	Mod	Lowest	Middle	Highest	EIRP (dBm)	EIRP(W)		
10	1	1	PI/2 BPSK	23.80	24.23	24.68	24.68	0.2938		
10	1	50		23.69	24.46	24.53				
10	25	12		23.87	24.52	24.66				
10	1	0		23.33	23.76	24.04				
10	1	51		23.13	23.92	24.00				
10	50	0		23.40	23.93	24.03				
10	1	1	QPSK	23.91	24.36	24.75			23.47	0.2223
10	1	50		23.69	24.53	24.45				
10	25	12		23.87	24.39	24.51				
10	1	0		23.02	23.30	23.60				
10	1	51		22.74	23.52	23.50				
10	50	0		22.83	23.41	23.51				
10	1	1	16-QAM	22.82	23.23	23.54	23.47	0.2223		
10	1	1	64-QAM	21.61	22.08	22.31				
10	1	1	256-QAM	18.82	19.33	19.63				
Limit	EIRP < 2W			Result			Pass			



NR n2 Maximum Average Power [dBm] (GT - LC = -0.07 dB)								
BW [MHz]	RB Size	RB Offset	Mod	Lowest	Middle	Highest	EIRP (dBm)	EIRP(W)
15	1	1	PI/2 BPSK	23.68	24.24	24.40	24.35	0.2723
15	1	77		23.74	24.39	24.31		
15	36	18		23.68	24.40	24.33		
15	1	0		23.38	23.63	23.92		
15	1	78		23.30	23.85	23.79		
15	75	0		23.20	23.98	23.88		
15	1	1	QPSK	23.78	24.21	24.38		
15	1	77		23.86	24.42	24.36		
15	36	18		23.65	24.42	24.34		
15	1	0		22.77	23.19	23.44		
15	1	78		22.69	23.34	23.36		
15	75	0		22.73	23.42	23.44		
15	1	1	16-QAM	22.66	23.27	23.24	23.20	0.2089
15	1	1	64-QAM	21.45	21.80	22.05		
15	1	1	256-QAM	18.74	19.21	19.36		
Limit	EIRP < 2W			Result			Pass	

NR n2 Maximum Average Power [dBm] (GT - LC = -0.07 dB)								
BW [MHz]	RB Size	RB Offset	Mod	Lowest	Middle	Highest	EIRP (dBm)	EIRP(W)
20	1	1	PI/2 BPSK	23.61	24.06	24.40	24.39	0.2748
20	1	104		23.90	24.35	24.32		
20	50	25		23.66	24.45	24.37		
20	1	0		23.19	23.48	23.90		
20	1	105		23.50	23.85	23.89		
20	100	0		23.18	23.83	23.90		
20	1	1	QPSK	23.56	23.90	24.42		
20	1	104		24.07	24.45	24.37		
20	50	25		23.60	24.40	24.46		
20	1	0		22.58	23.00	23.44		
20	1	105		23.00	23.32	23.34		
20	100	0		22.74	23.42	23.40		
20	1	1	16-QAM	22.51	23.04	23.32	23.25	0.2113
20	1	1	64-QAM	21.30	21.76	22.04		
20	1	1	256-QAM	18.60	19.13	19.31		
Limit	EIRP < 2W			Result			Pass	



NR n5 Maximum Average Power [dBm] (GT - LC = -2.42 dB)								
BW [MHz]	RB Size	RB Offset	Mod	Lowest	Middle	Highest	ERP (dBm)	ERP(W)
5	1	1	PI/2 BPSK	24.02	24.26	24.81	20.42	0.1102
5	1	23		24.00	24.46	24.97		
5	12	6		24.01	24.30	24.85		
5	1	0		23.57	23.77	24.31		
5	1	24		23.42	23.92	24.48		
5	25	0		23.55	23.87	24.35		
5	1	1	QPSK	24.05	24.40	24.82		
5	1	23		23.92	24.47	24.99		
5	12	6		24.00	24.27	24.84		
5	1	0		23.05	23.34	23.81		
5	1	24		22.97	23.33	24.00		
5	25	0		22.98	23.33	23.92		
5	1	1	16-QAM	22.96	23.23	23.69	19.12	0.0817
5	1	1	64-QAM	21.67	22.02	22.42		
5	1	1	256-QAM	19.07	19.27	19.82		
Limit	ERP < 7W			Result			Pass	

NR n5 Maximum Average Power [dBm] (GT - LC = -2.42 dB)								
BW [MHz]	RB Size	RB Offset	Mod	Lowest	Middle	Highest	ERP (dBm)	ERP(W)
10	1	1	PI/2 BPSK	23.98	24.04	24.42	20.30	0.1072
10	1	50		24.10	24.60	24.86		
10	25	12		23.97	24.38	24.70		
10	1	0		23.47	23.59	23.94		
10	1	51		23.68	24.00	24.40		
10	50	0		23.48	23.83	24.13		
10	1	1	QPSK	23.99	24.04	24.48		
10	1	50		24.12	24.61	24.87		
10	25	12		23.93	24.38	24.71		
10	1	0		23.19	23.05	23.35		
10	1	51		23.17	23.60	23.83		
10	50	0		22.95	23.31	23.54		
10	1	1	16-QAM	22.91	23.05	23.36	18.79	0.0757
10	1	1	64-QAM	21.85	21.70	22.15		
10	1	1	256-QAM	18.92	19.10	19.37		
Limit	ERP < 7W			Result			Pass	



NR n5 Maximum Average Power [dBm] (GT - LC = -2.42 dB)								
BW [MHz]	RB Size	RB Offset	Mod	Lowest	Middle	Highest	ERP (dBm)	ERP(W)
15	1	1	PI/2 BPSK	23.74	23.90	24.16	20.29	0.1069
15	1	77		24.33	24.56	24.74		
15	36	18		23.99	24.29	24.40		
15	1	0		23.34	23.52	23.65		
15	1	78		23.82	24.10	24.25		
15	75	0		23.45	23.85	24.01		
15	1	1	QPSK	23.92	24.01	24.11		
15	1	77		24.32	24.76	24.86		
15	36	18		24.04	24.29	24.36		
15	1	0		23.01	23.03	23.17		
15	1	78		23.35	23.62	23.64		
15	75	0		22.96	23.35	23.50		
15	1	1	16-QAM	22.79	22.94	23.11	18.54	0.0714
15	1	1	64-QAM	21.82	21.66	21.77		
15	1	1	256-QAM	19.36	19.00	19.08		
Limit	ERP < 7W			Result			Pass	

NR n5 Maximum Average Power [dBm] (GT - LC = -2.42 dB)								
BW [MHz]	RB Size	RB Offset	Mod	Lowest	Middle	Highest	ERP (dBm)	ERP(W)
20	1	1	PI/2 BPSK	23.77	23.85	23.96	20.25	0.1059
20	1	104		24.50	24.80	24.74		
20	50	25		24.14	24.29	24.35		
20	1	0		23.42	23.43	23.40		
20	1	105		24.03	24.24	24.21		
20	100	0		23.62	23.83	23.84		
20	1	1	QPSK	23.86	23.89	23.92		
20	1	104		24.57	24.82	24.78		
20	50	25		24.16	24.25	24.32		
20	1	0		22.97	22.95	22.98		
20	1	105		23.47	23.76	23.77		
20	100	0		23.10	23.31	23.33		
20	1	1	16-QAM	22.73	22.90	22.88	18.33	0.0681
20	1	1	64-QAM	21.45	21.54	21.59		
20	1	1	256-QAM	18.76	18.85	18.90		
Limit	ERP < 7W			Result			Pass	



NR n7 Maximum Average Power [dBm] (GT - LC = 2.09 dB)								
BW [MHz]	RB Size	RB Offset	Mod	Lowest	Middle	Highest	EIRP (dBm)	EIRP(W)
5	1	1	PI/2 BPSK	23.91	24.03	24.32	26.46	0.4426
5	1	23		23.99	24.07	24.35		
5	12	6		23.98	24.02	24.36		
5	1	0		23.37	23.58	23.86		
5	1	24		23.40	23.51	23.82		
5	25	0		23.40	23.60	23.89		
5	1	1	QPSK	23.86	24.05	24.31		
5	1	23		23.90	24.08	24.37		
5	12	6		23.89	24.03	24.32		
5	1	0		22.91	23.05	23.35		
5	1	24		22.93	23.01	23.38		
5	25	0		22.90	23.07	23.39		
5	1	1	16-QAM	22.82	22.96	23.25	25.34	0.3420
5	1	1	64-QAM	21.54	21.66	21.92		
5	1	1	256-QAM	18.76	18.93	19.23		
Limit	EIRP < 2W			Result			Pass	

NR n7 Maximum Average Power [dBm] (GT - LC = 2.09 dB)								
BW [MHz]	RB Size	RB Offset	Mod	Lowest	Middle	Highest	EIRP (dBm)	EIRP(W)
10	1	1	PI/2 BPSK	23.62	23.84	24.18	26.44	0.4406
10	1	50		23.71	24.11	24.24		
10	25	12		23.84	24.09	24.35		
10	1	0		23.28	23.44	23.78		
10	1	51		23.28	23.57	23.85		
10	50	0		23.23	23.61	23.82		
10	1	1	QPSK	23.74	24.05	24.32		
10	1	50		23.75	24.09	24.31		
10	25	12		23.73	24.04	24.30		
10	1	0		22.73	22.99	23.30		
10	1	51		22.75	23.04	23.39		
10	50	0		22.76	23.08	23.25		
10	1	1	16-QAM	22.66	22.96	23.14	25.23	0.3334
10	1	1	64-QAM	21.38	21.71	21.96		
10	1	1	256-QAM	18.61	18.91	19.19		
Limit	EIRP < 2W			Result			Pass	



NR n7 Maximum Average Power [dBm] (GT - LC = 2.09 dB)								
BW [MHz]	RB Size	RB Offset	Mod	Lowest	Middle	Highest	EIRP (dBm)	EIRP(W)
15	1	1	PI/2 BPSK	23.65	23.87	24.17	26.42	0.4385
15	1	77		23.83	23.96	24.26		
15	36	18		23.73	23.95	24.33		
15	1	0		23.14	23.42	23.66		
15	1	78		23.34	23.52	23.75		
15	75	0		23.27	23.45	23.83		
15	1	1	QPSK	23.68	23.86	24.19	26.42	0.4385
15	1	77		23.87	24.07	24.27		
15	36	18		23.69	23.97	24.30		
15	1	0		22.65	22.83	23.13		
15	1	78		22.83	23.04	23.30		
15	75	0		22.77	22.99	23.33		
15	1	1	16-QAM	22.70	22.69	23.26	25.35	0.3428
15	1	1	64-QAM	21.38	21.46	21.74		
15	1	1	256-QAM	18.68	18.86	19.22		
Limit	EIRP < 2W			Result			Pass	

NR n7 Maximum Average Power [dBm] (GT - LC = 2.09 dB)								
BW [MHz]	RB Size	RB Offset	Mod	Lowest	Middle	Highest	EIRP (dBm)	EIRP(W)
20	1	1	PI/2 BPSK	23.60	23.75	24.06	26.34	0.4305
20	1	104		23.71	24.01	24.21		
20	50	25		23.74	23.96	24.19		
20	1	0		23.10	23.28	23.56		
20	1	105		23.32	23.49	23.69		
20	100	0		23.30	23.50	23.76		
20	1	1	QPSK	23.66	23.75	24.06	26.34	0.4305
20	1	104		23.86	24.02	24.22		
20	50	25		23.76	23.94	24.25		
20	1	0		22.67	22.77	23.04		
20	1	105		22.86	23.01	23.16		
20	100	0		22.78	22.93	23.29		
20	1	1	16-QAM	22.67	22.74	23.02	25.11	0.3243
20	1	1	64-QAM	21.33	21.50	21.70		
20	1	1	256-QAM	18.60	18.78	19.03		
Limit	EIRP < 2W			Result			Pass	



NR n38 Maximum Average Power [dBm] (GT - LC = -0.54 dB)										
BW [MHz]	RB Size	RB Offset	Mod	Lowest	Middle	Highest	EIRP (dBm)	EIRP(W)		
20	1	1	PI/2 BPSK	23.69	23.60	23.67	23.22	0.2099		
20	1	49		23.71	23.68	23.72				
20	25	12		23.76	23.67	23.73				
20	1	0		23.19	23.13	23.23				
20	1	50		23.24	23.18	23.25				
20	50	0		23.20	23.17	23.23				
20	1	1	QPSK	23.70	23.55	23.71				
20	1	49		23.73	23.64	23.75				
20	25	12		23.71	23.65	23.72				
20	1	0		22.61	22.57	22.66				
20	1	50		22.69	22.68	22.73				
20	50	0		22.75	22.63	22.72				
20	1	1	16-QAM	22.65	22.60	22.71			22.17	0.1648
20	1	1	64-QAM	21.29	21.19	21.23				
20	1	1	256-QAM	18.85	18.75	18.80				
Limit	EIRP < 2W			Result			Pass			

NR n38 Maximum Average Power [dBm] (GT - LC = -0.54 dB)										
BW [MHz]	RB Size	RB Offset	Mod	Lowest	Middle	Highest	EIRP (dBm)	EIRP(W)		
30	1	1	PI/2 BPSK	23.58	23.65	23.73	23.32	0.2148		
30	1	76		23.81	23.86	23.81				
30	36	18		23.59	23.72	23.78				
30	1	0		23.17	23.18	23.22				
30	1	77		23.32	23.36	23.30				
30	75	0		23.24	23.29	23.30				
30	1	1	QPSK	23.62	23.66	23.74				
30	1	76		23.82	23.85	23.77				
30	36	18		23.58	23.69	23.73				
30	1	0		22.53	22.00	22.63				
30	1	77		22.75	22.87	22.78				
30	75	0		22.73	22.75	22.82				
30	1	1	16-QAM	22.72	22.66	22.75			22.21	0.1663
30	1	1	64-QAM	21.12	21.27	21.35				
30	1	1	256-QAM	18.92	18.76	19.03				
Limit	EIRP < 2W			Result			Pass			



NR n38 Maximum Average Power [dBm] (GT - LC = -0.54 dB)								
BW [MHz]	RB Size	RB Offset	Mod	Lowest	Middle	Highest	EIRP (dBm)	EIRP(W)
40	1	1	PI/2 BPSK	23.83	23.50	23.63	23.36	0.2168
40	1	104		23.89	23.83	23.89		
40	50	25		23.77	23.78	23.90		
40	1	0		23.37	23.15	23.29		
40	1	105		23.39	23.37	23.42		
40	100	0		23.29	23.31	23.34		
40	1	1	QPSK	23.80	23.60	23.64		
40	1	104		23.85	23.86	23.88		
40	50	25		23.77	23.71	23.79		
40	1	0		22.81	22.62	22.66		
40	1	105		22.89	22.86	22.87		
40	100	0		22.76	22.78	22.85		
40	1	1	16-QAM	22.84	22.72	22.66	22.30	0.1698
40	1	1	64-QAM	21.50	21.33	21.33		
40	1	1	256-QAM	19.09	18.89	18.91		
Limit	EIRP < 2W			Result			Pass	



NR n41 Maximum Average Power [dBm] (GT - LC = -0.51 dB)								
BW [MHz]	RB Size	RB Offset	Mod	Lowest	Middle	Highest	EIRP (dBm)	EIRP(W)
20	1	1	PI/2 BPSK	25.64	25.93	25.88	25.47	0.3524
20	1	49		25.77	25.94	25.80		
20	25	12		25.74	25.96	25.96		
20	1	0		22.14	22.49	22.40		
20	1	50		22.25	22.37	22.40		
20	50	0		25.27	25.51	25.45		
20	1	1	QPSK	25.59	25.93	25.88		
20	1	49		25.73	25.88	25.78		
20	25	12		25.63	25.98	25.91		
20	1	0		22.13	22.40	22.42		
20	1	50		22.27	22.34	22.35		
20	50	0		24.73	25.00	24.89		
20	1	1	16-QAM	24.86	24.98	25.00	24.49	0.2812
20	1	1	64-QAM	23.28	23.49	23.55		
20	1	1	256-QAM	20.82	21.10	21.12		
Limit	EIRP < 2W			Result			Pass	

NR n41 Maximum Average Power [dBm] (GT - LC = -0.51 dB)								
BW [MHz]	RB Size	RB Offset	Mod	Lowest	Middle	Highest	EIRP (dBm)	EIRP(W)
30	1	1	PI/2 BPSK	25.67	26.00	25.98	25.61	0.3639
30	1	76		25.94	26.12	26.08		
30	36	18		25.80	25.92	26.08		
30	1	0		22.27	22.44	22.54		
30	1	77		22.47	22.61	22.60		
30	75	0		25.36	25.51	25.67		
30	1	1	QPSK	25.64	25.85	25.90		
30	1	76		25.87	26.04	26.08		
30	36	18		25.80	25.84	26.12		
30	1	0		22.21	22.34	22.52		
30	1	77		22.44	22.54	22.56		
30	75	0		24.87	24.99	25.14		
30	1	1	16-QAM	24.74	24.95	25.04	24.53	0.2838
30	1	1	64-QAM	23.23	23.52	23.60		
30	1	1	256-QAM	20.87	21.15	21.27		
Limit	EIRP < 2W			Result			Pass	



NR n41 Maximum Average Power [dBm] (GT - LC = -0.51 dB)										
BW [MHz]	RB Size	RB Offset	Mod	Lowest	Middle	Highest	EIRP (dBm)	EIRP(W)		
40	1	1	PI/2 BPSK	25.64	26.00	25.94	25.60	0.3631		
40	1	104		25.91	26.11	26.03				
40	50	25		25.69	25.91	26.05				
40	1	0		22.23	22.51	22.52				
40	1	105		22.42	22.62	22.56				
40	100	0		25.37	25.45	25.53				
40	1	1	QPSK	25.65	25.94	25.90			24.53	0.2838
40	1	104		25.89	26.05	26.01				
40	50	25		25.73	25.86	25.99				
40	1	0		22.16	22.43	22.43				
40	1	105		22.41	22.52	22.50				
40	100	0		24.80	24.90	25.04				
40	1	1	16-QAM	24.83	24.96	25.04	24.53	0.2838		
40	1	1	64-QAM	23.34	23.51	23.67				
40	1	1	256-QAM	20.88	21.13	21.13				
Limit	EIRP < 2W			Result			Pass			

NR n41 Maximum Average Power [dBm] (GT - LC = -0.51 dB)										
BW [MHz]	RB Size	RB Offset	Mod	Lowest	Middle	Highest	EIRP (dBm)	EIRP(W)		
50	1	1	PI/2 BPSK	25.63	25.80	25.98	25.48	0.3532		
50	1	131		25.69	25.97	25.85				
50	64	32		25.82	25.79	25.96				
50	1	0		22.17	22.29	22.54				
50	1	132		22.20	22.51	22.33				
50	128	0		25.29	25.42	25.48				
50	1	1	QPSK	25.57	25.77	25.94			24.68	0.2938
50	1	131		25.61	25.99	25.80				
50	64	32		25.80	25.92	25.92				
50	1	0		22.12	22.29	22.50				
50	1	132		22.16	22.58	22.37				
50	128	0		24.77	24.88	24.88				
50	1	1	16-QAM	24.70	24.87	25.19	24.68	0.2938		
50	1	1	64-QAM	23.23	23.54	23.60				
50	1	1	256-QAM	20.89	21.01	21.34				
Limit	EIRP < 2W			Result			Pass			



NR n41 Maximum Average Power [dBm] (GT - LC = -0.51 dB)								
BW [MHz]	RB Size	RB Offset	Mod	Lowest	Middle	Highest	EIRP (dBm)	EIRP(W)
60	1	1	PI/2 BPSK	25.44	25.77	25.93	25.44	0.3499
60	1	160		25.61	25.95	25.71		
60	81	40		25.69	25.88	25.81		
60	1	0		21.99	22.30	22.46		
60	1	161		22.13	22.46	22.25		
60	162	0		25.19	25.46	25.37		
60	1	1	QPSK	25.51	25.69	25.88		
60	1	160		25.61	25.90	25.71		
60	81	40		25.69	25.89	25.84		
60	1	0		21.98	22.18	22.41		
60	1	161		22.10	22.45	22.19		
60	162	0		24.64	24.86	24.83		
60	1	1	16-QAM	24.65	24.74	24.98	24.47	0.2799
60	1	1	64-QAM	23.14	23.24	23.62		
60	1	1	256-QAM	20.68	21.05	21.10		
Limit	EIRP < 2W			Result			Pass	

NR n41 Maximum Average Power [dBm] (GT - LC = -0.51 dB)								
BW [MHz]	RB Size	RB Offset	Mod	Lowest	Middle	Highest	EIRP (dBm)	EIRP(W)
80	1	1	PI/2 BPSK	25.23	25.63	25.64	25.22	0.3327
80	1	215		25.40	25.73	25.67		
80	108	54		25.41	25.70	25.70		
80	1	0		21.87	22.10	22.10		
80	1	216		21.96	22.15	22.13		
80	216	0		24.95	25.20	25.21		
80	1	1	QPSK	25.23	25.50	25.55		
80	1	215		25.41	25.62	25.60		
80	108	54		25.44	25.67	25.68		
80	1	0		21.78	22.00	22.08		
80	1	216		21.91	22.13	22.06		
80	216	0		24.44	24.65	24.71		
80	1	1	16-QAM	24.34	24.63	24.68	24.17	0.2612
80	1	1	64-QAM	22.96	23.23	23.17		
80	1	1	256-QAM	20.54	20.72	20.77		
Limit	EIRP < 2W			Result			Pass	



NR n41 Maximum Average Power [dBm] (GT - LC = -0.51 dB)										
BW [MHz]	RB Size	RB Offset	Mod	Lowest	Middle	Highest	EIRP (dBm)	EIRP(W)		
90	1	1	PI/2 BPSK	25.27	25.57	25.63	25.30	0.3388		
90	1	243		25.26	25.70	25.59				
90	120	60		25.53	25.60	25.77				
90	1	0		21.85	22.11	22.03				
90	1	244		21.82	22.20	22.11				
90	243	0		24.94	25.17	25.22				
90	1	1	QPSK	25.25	25.57	25.53				
90	1	243		25.30	25.69	25.54				
90	120	60		25.47	25.61	25.81				
90	1	0		21.78	22.07	22.01				
90	1	244		21.80	22.21	22.00				
90	243	0		24.47	24.65	24.77				
90	1	1	16-QAM	24.36	24.77	24.61			24.26	0.2667
90	1	1	64-QAM	22.84	23.18	23.26				
90	1	1	256-QAM	20.65	20.71	20.74				
Limit	EIRP < 2W			Result			Pass			

NR n41 Maximum Average Power [dBm] (GT - LC = -0.51 dB)										
BW [MHz]	RB Size	RB Offset	Mod	Lowest	Middle	Highest	EIRP (dBm)	EIRP(W)		
100	1	1	PI/2 BPSK	25.35	25.64	25.47	25.24	0.3342		
100	1	271		25.38	25.59	25.75				
100	135	67		25.50	25.69	25.67				
100	1	0		21.88	22.12	22.01				
100	1	272		21.87	22.10	22.20				
100	270	0		24.35	25.16	25.18				
100	1	1	QPSK	25.26	25.54	25.49				
100	1	271		25.30	25.56	25.67				
100	135	67		25.41	25.72	25.69				
100	1	0		21.81	22.02	22.00				
100	1	272		21.80	22.12	22.20				
100	270	0		24.31	24.64	24.64				
100	1	1	16-QAM	24.21	24.60	24.54			24.09	0.2564
100	1	1	64-QAM	22.57	23.28	23.13				
100	1	1	256-QAM	20.57	20.72	20.77				
Limit	EIRP < 2W			Result			Pass			



NR n66 Maximum Average Power [dBm] (GT - LC = 2.18 dB)								
BW [MHz]	RB Size	RB Offset	Mod	Lowest	Middle	Highest	EIRP (dBm)	EIRP(W)
5	1	1	PI/2 BPSK	23.38	23.72	24.43	26.63	0.4603
5	1	23		23.52	23.76	24.41		
5	12	6		23.54	23.71	24.25		
5	1	0		23.01	23.20	23.33		
5	1	24		23.05	23.29	23.38		
5	25	0		22.00	23.26	23.21		
5	1	1	QPSK	23.53	23.76	24.30		
5	1	23		23.50	23.63	24.45		
5	12	6		23.51	23.83	24.28		
5	1	0		22.56	22.83	23.33		
5	1	24		22.36	22.90	23.31		
5	25	0		22.50	22.80	23.24		
5	1	1	16-QAM	22.41	22.68	23.19	25.37	0.3443
5	1	1	64-QAM	21.22	21.47	22.05		
5	1	1	256-QAM	18.58	18.80	19.97		
Limit	EIRP < 1W			Result			Pass	

NR n66 Maximum Average Power [dBm] (GT - LC = 2.18 dB)								
BW [MHz]	RB Size	RB Offset	Mod	Lowest	Middle	Highest	EIRP (dBm)	EIRP(W)
10	1	1	PI/2 BPSK	23.61	23.76	24.32	26.54	0.4508
10	1	50		23.51	23.95	24.31		
10	25	12		23.68	23.82	24.36		
10	1	0		23.11	23.21	23.85		
10	1	51		23.58	23.43	23.80		
10	50	0		23.19	23.37	23.84		
10	1	1	QPSK	23.65	23.72	24.33		
10	1	50		23.59	23.83	24.20		
10	25	12		23.65	23.84	24.35		
10	1	0		22.60	22.76	23.23		
10	1	51		22.50	22.93	23.20		
10	50	0		22.63	22.80	23.36		
10	1	1	16-QAM	22.56	22.70	23.30	25.48	0.3532
10	1	1	64-QAM	21.35	21.46	22.02		
10	1	1	256-QAM	18.40	18.61	19.24		
Limit	EIRP < 1W			Result			Pass	



NR n66 Maximum Average Power [dBm] (GT - LC = 2.18 dB)								
BW [MHz]	RB Size	RB Offset	Mod	Lowest	Middle	Highest	EIRP (dBm)	EIRP(W)
15	1	1	PI/2 BPSK	23.53	23.67	23.91	26.35	0.4315
15	1	77		23.62	23.80	24.08		
15	36	18		23.45	23.81	24.17		
15	1	0		22.93	23.16	23.40		
15	1	78		23.00	23.44	23.64		
15	75	0		22.86	23.27	23.47		
15	1	1	QPSK	23.44	23.71	24.10		
15	1	77		23.50	23.85	24.15		
15	36	18		23.48	23.68	24.11		
15	1	0		22.54	22.65	22.85		
15	1	78		22.56	22.83	22.85		
15	75	0		22.28	22.77	23.15		
15	1	1	16-QAM	22.38	22.48	22.83	25.01	0.3170
15	1	1	64-QAM	21.17	21.26	21.57		
15	1	1	256-QAM	18.40	18.60	18.92		
Limit	EIRP < 1W			Result			Pass	

NR n66 Maximum Average Power [dBm] (GT - LC = 2.18 dB)								
BW [MHz]	RB Size	RB Offset	Mod	Lowest	Middle	Highest	EIRP (dBm)	EIRP(W)
20	1	1	PI/2 BPSK	23.42	23.59	23.91	26.32	0.4285
20	1	104		23.61	23.84	23.92		
20	50	25		23.43	23.71	24.10		
20	1	0		22.93	23.15	23.46		
20	1	105		23.06	23.44	23.57		
20	100	0		23.05	23.32	23.65		
20	1	1	QPSK	23.54	23.65	23.92		
20	1	104		23.58	23.94	24.14		
20	50	25		23.44	23.80	24.12		
20	1	0		23.52	22.46	23.00		
20	1	105		22.60	22.82	23.25		
20	100	0		22.42	22.85	23.01		
20	1	1	16-QAM	22.41	22.57	22.89	25.07	0.3214
20	1	1	64-QAM	21.18	21.30	21.65		
20	1	1	256-QAM	18.48	18.55	18.87		
Limit	EIRP < 1W			Result			Pass	



NR n66 Maximum Average Power [dBm] (GT - LC = 2.18 dB)										
BW [MHz]	RB Size	RB Offset	Mod	Lowest	Middle	Highest	EIRP (dBm)	EIRP(W)		
30	1	1	PI/2 BPSK	23.57	23.50	23.74	26.45	0.4416		
30	1	158		23.62	23.97	24.07				
30	80	40		23.47	23.77	24.27				
30	1	0		23.04	22.91	23.46				
30	1	159		23.06	23.55	23.71				
30	160	0		23.00	23.28	23.62				
30	1	1	QPSK	23.54	23.64	23.81			26.45	0.4416
30	1	158		23.60	24.04	24.20				
30	80	40		23.55	23.00	24.24				
30	1	0		22.64	22.60	22.39				
30	1	159		22.68	22.94	23.72				
30	160	0		22.53	22.78	23.08				
30	1	1	16-QAM	22.50	22.59	22.81	24.99	0.3155		
30	1	1	64-QAM	21.19	21.24	21.58				
30	1	1	256-QAM	18.46	18.52	18.80				
Limit	EIRP < 1W			Result			Pass			

NR n66 Maximum Average Power [dBm] (GT - LC = 2.18 dB)										
BW [MHz]	RB Size	RB Offset	Mod	Lowest	Middle	Highest	EIRP (dBm)	EIRP(W)		
40	1	1	PI/2 BPSK	23.41	23.45	23.63	26.36	0.4325		
40	1	214		23.76	24.14	24.15				
40	108	54		23.44	23.80	24.13				
40	1	0		22.94	23.03	23.16				
40	1	215		23.24	23.54	23.66				
40	216	0		23.03	23.36	23.47				
40	1	1	QPSK	23.58	23.54	23.52			26.36	0.4325
40	1	214		23.88	24.15	24.18				
40	108	54		23.60	23.88	24.02				
40	1	0		22.40	22.49	22.52				
40	1	215		22.48	22.90	23.30				
40	216	0		22.61	22.90	23.08				
40	1	1	16-QAM	22.45	22.40	22.51	24.69	0.2944		
40	1	1	64-QAM	21.16	21.16	21.41				
40	1	1	256-QAM	18.34	18.35	18.52				
Limit	EIRP < 1W			Result			Pass			



NR n71 Maximum Average Power [dBm] (GT - LC = -0.52 dB)								
BW [MHz]	RB Size	RB Offset	Mod	Lowest	Middle	Highest	ERP (dBm)	ERP(W)
5	1	1	PI/2 BPSK	24.18	24.04	24.33	21.73	0.1489
5	1	23		24.35	24.18	24.26		
5	12	6		24.24	24.18	24.32		
5	1	0		23.74	23.62	23.80		
5	1	24		23.65	23.73	23.74		
5	25	0		23.66	23.76	23.94		
5	1	1	QPSK	24.31	24.13	24.34		
5	1	23		24.13	24.18	24.23		
5	12	6		24.28	24.22	24.40		
5	1	0		23.27	23.11	23.34		
5	1	24		23.29	23.28	23.30		
5	25	0		23.20	23.15	23.38		
5	1	1	16-QAM	23.28	23.09	23.36	20.69	0.1172
5	1	1	64-QAM	21.95	21.76	22.02		
5	1	1	256-QAM	19.18	19.19	19.33		
Limit	ERP < 3W			Result			Pass	

NR n71 Maximum Average Power [dBm] (GT - LC = -0.52 dB)								
BW [MHz]	RB Size	RB Offset	Mod	Lowest	Middle	Highest	ERP (dBm)	ERP(W)
10	1	1	PI/2 BPSK	24.21	24.08	24.42	21.75	0.1496
10	1	50		24.13	24.31	24.23		
10	25	12		24.17	24.29	24.32		
10	1	0		23.75	23.58	23.92		
10	1	51		23.48	23.87	23.78		
10	50	0		23.64	23.74	23.82		
10	1	1	QPSK	24.34	24.01	24.38		
10	1	50		24.10	24.31	24.25		
10	25	12		24.22	24.26	24.32		
10	1	0		23.28	23.03	23.47		
10	1	51		23.18	23.32	23.36		
10	50	0		23.14	23.25	23.36		
10	1	1	16-QAM	23.25	23.15	23.46	20.79	0.1199
10	1	1	64-QAM	21.94	21.71	22.09		
10	1	1	256-QAM	19.54	19.01	19.35		
Limit	ERP < 3W			Result			Pass	



NR n71 Maximum Average Power [dBm] (GT - LC = -0.52 dB)								
BW [MHz]	RB Size	RB Offset	Mod	Lowest	Middle	Highest	ERP (dBm)	ERP(W)
15	1	1	PI/2 BPSK	23.97	23.91	24.10	21.59	0.1442
15	1	77		24.09	24.26	24.16		
15	36	18		23.91	24.25	24.17		
15	1	0		23.57	23.38	23.67		
15	1	78		23.52	23.76	23.61		
15	75	0		23.46	23.64	23.72		
15	1	1	QPSK	24.00	23.97	24.25		
15	1	77		24.08	24.23	24.14		
15	36	18		24.03	24.17	24.16		
15	1	0		23.10	22.90	23.18		
15	1	78		23.05	23.25	22.93		
15	75	0		23.08	23.11	23.27		
15	1	1	16-QAM	23.32	23.05	23.30	20.65	0.1161
15	1	1	64-QAM	21.66	21.51	21.76		
15	1	1	256-QAM	19.00	18.89	19.12		
Limit	ERP < 3W			Result			Pass	

NR n71 Maximum Average Power [dBm] (GT - LC = -0.52 dB)								
BW [MHz]	RB Size	RB Offset	Mod	Lowest	Middle	Highest	ERP (dBm)	ERP(W)
20	1	1	PI/2 BPSK	24.07	23.84	24.27	21.76	0.1500
20	1	104		24.08	24.43	24.06		
20	50	25		23.94	24.21	24.24		
20	1	0		23.63	23.35	23.63		
20	1	105		23.62	23.64	23.50		
20	100	0		23.54	23.55	23.70		
20	1	1	QPSK	24.17	23.85	24.14		
20	1	104		23.98	24.20	24.05		
20	50	25		23.88	24.15	24.26		
20	1	0		23.02	23.01	23.10		
20	1	105		24.04	23.26	23.12		
20	100	0		22.96	23.12	23.33		
20	1	1	16-QAM	23.97	22.95	23.08	21.30	0.1349
20	1	1	64-QAM	21.64	21.73	21.77		
20	1	1	256-QAM	19.00	18.92	18.99		
Limit	ERP < 3W			Result			Pass	



FR1 n2

Peak-to-Average Ratio

Mode	FR1 n2 / 20MHz / DFT-S OFDM				
Mod.	PI/2 BPSK	QPSK	16QAM	64QAM	Limit: 13dB
RB Size	Full RB	Full RB	Full RB	Full RB	Result
Middle CH	4.12	4.66	5.66	5.98	PASS
Mode	FR1 n2 / 20MHz / DFT-S OFDM				
Mod.	256QAM				Limit: 13dB
RB Size	Full RB				Result
Middle CH	6.74				PASS



FR1 n2 / 20MHz / DFT-S OFDM / Middle Channel / Full RB

PI/2 BPSK

QPSK

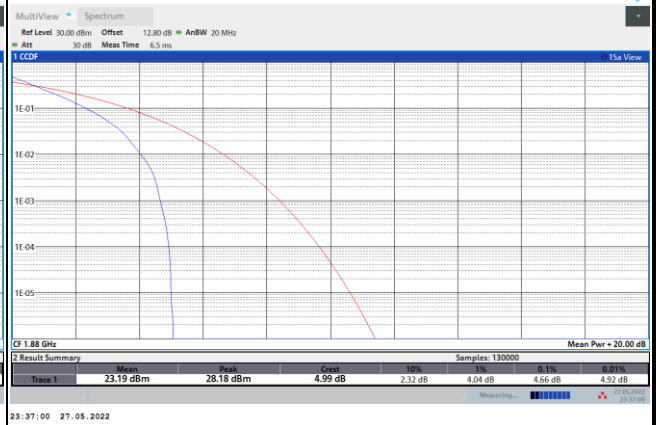
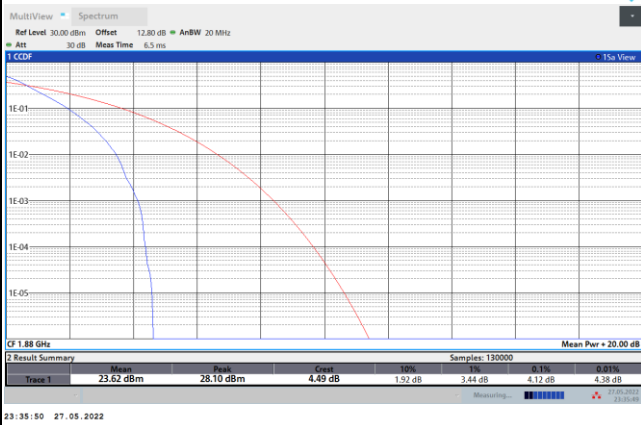

16QAM

64QAM

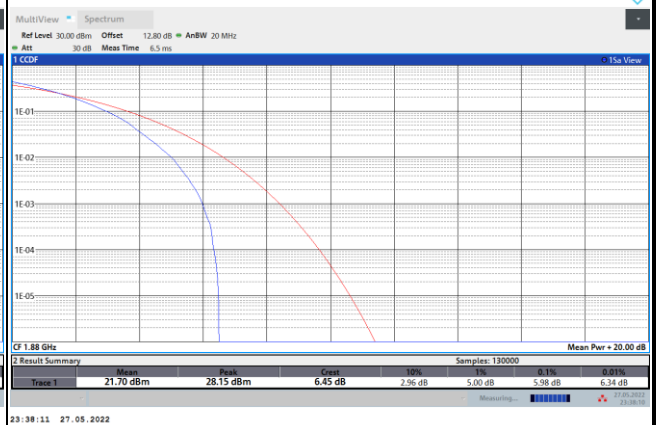
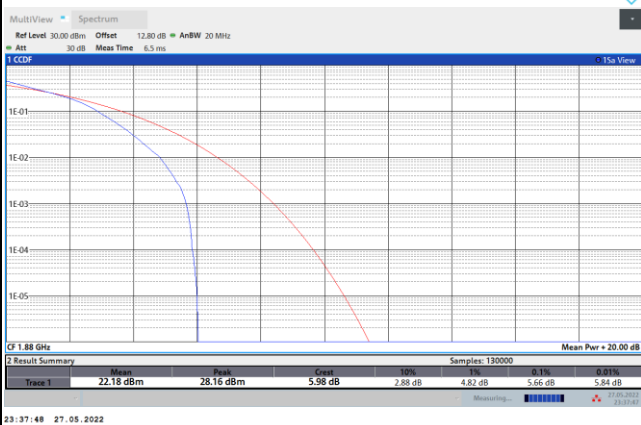

256QAM

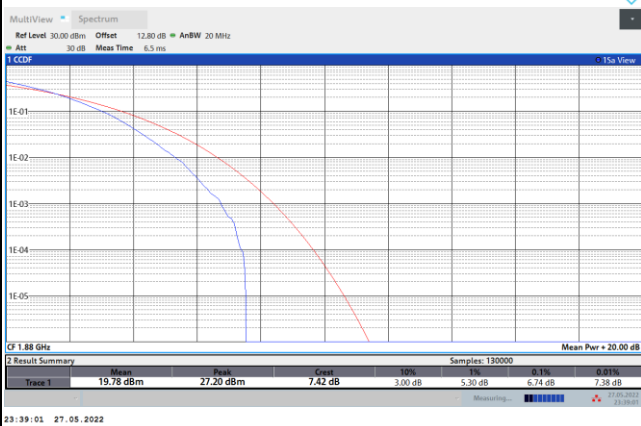



26dB Bandwidth

Mode	FR1 n2 : 26dB BW(MHz) / DFT-S OFDM							
BW	5MHz		10MHz		15MHz		20MHz	
Mod.	PI/2 BPSK		PI/2 BPSK		PI/2 BPSK		PI/2 BPSK	
Middle CH	4.89		9.47		14.27		18.82	

Mode	FR1 n2 : 26dB BW(MHz) / CP OFDM							
BW	5MHz		10MHz		15MHz		20MHz	
Mod.	QPSK	16QAM	QPSK	16QAM	QPSK	16QAM	QPSK	16QAM
Middle CH	4.95	4.92	9.89	9.85	14.96	15.05	19.86	19.82
Mod.	64QAM		256QAM		64QAM		256QAM	
Middle CH	4.97	4.91	9.93	9.87	14.99	14.99	19.82	19.82



FR1 n2 / 5MHz / DFT-S OFDM / Middle Channel / Full RB

PI/2 BPSK

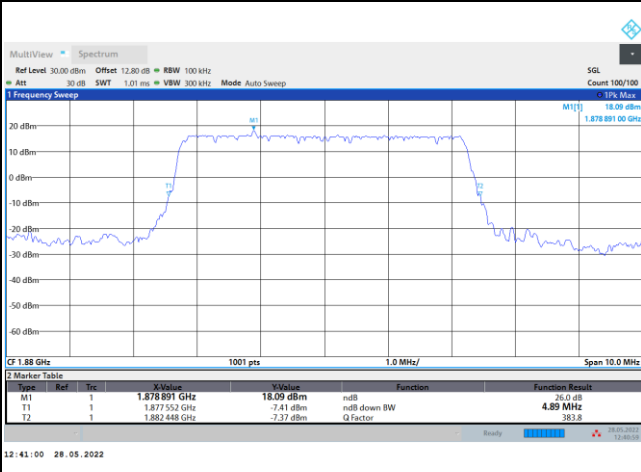

FR1 n2 / 5MHz / CP OFDM / Middle Channel / Full RB

QPSK

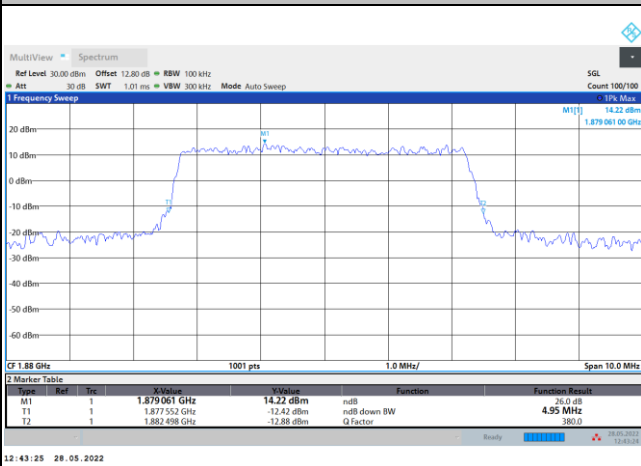

16QAM

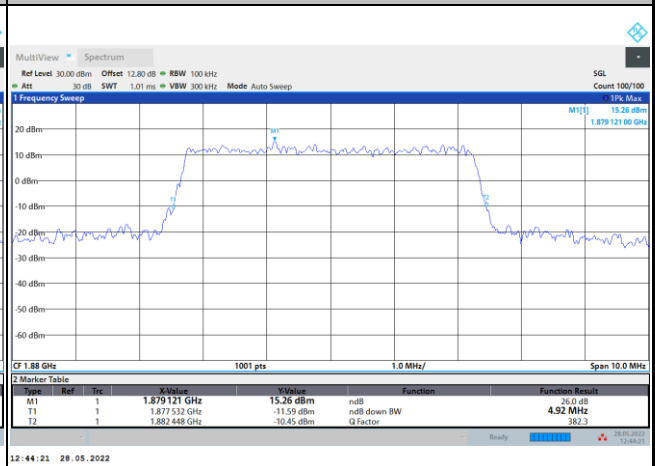

64QAM

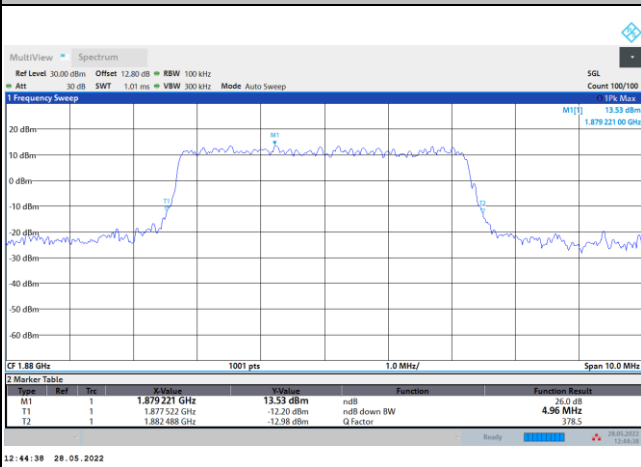

256QAM

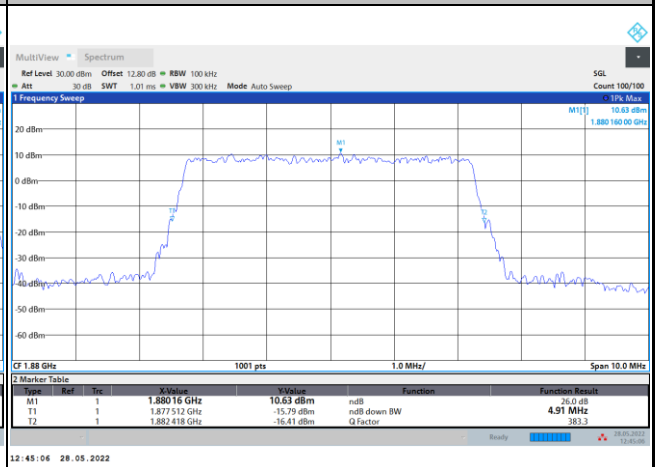



FR1 n2 / 10MHz / DFT-S OFDM / Middle Channel / Full RB

PI/2 BPSK

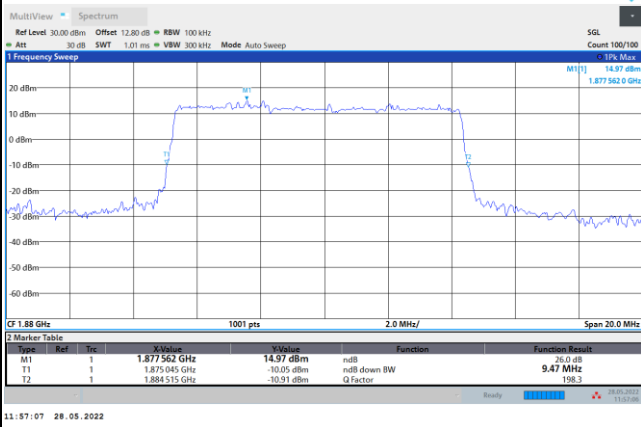

FR1 n2 / 10MHz / CP OFDM / Middle Channel / Full RB

QPSK

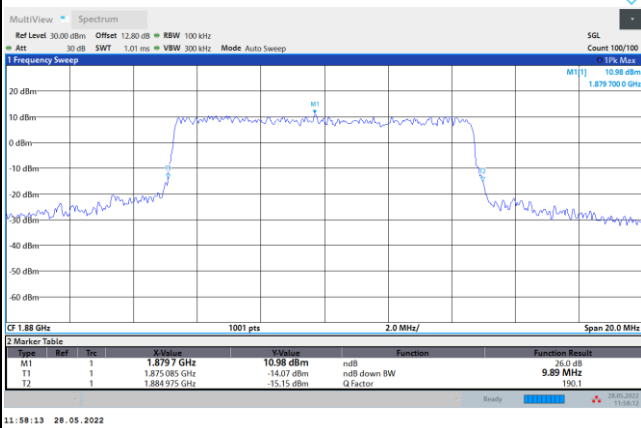

16QAM

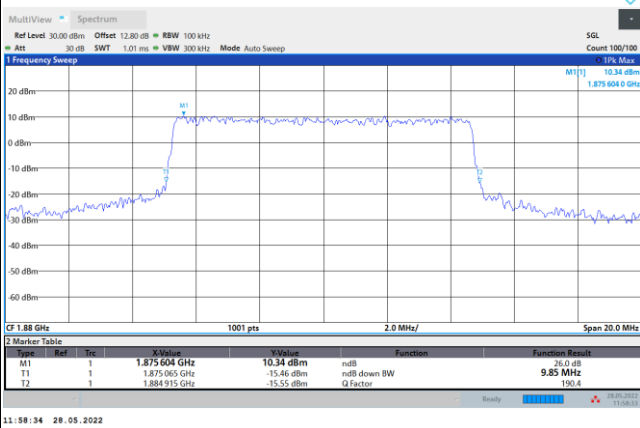

64QAM

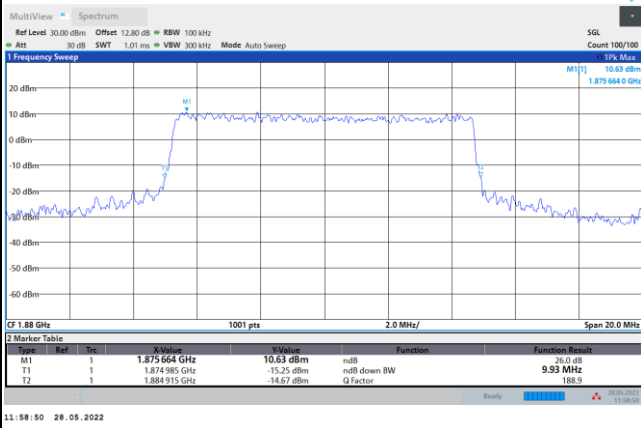

256QAM

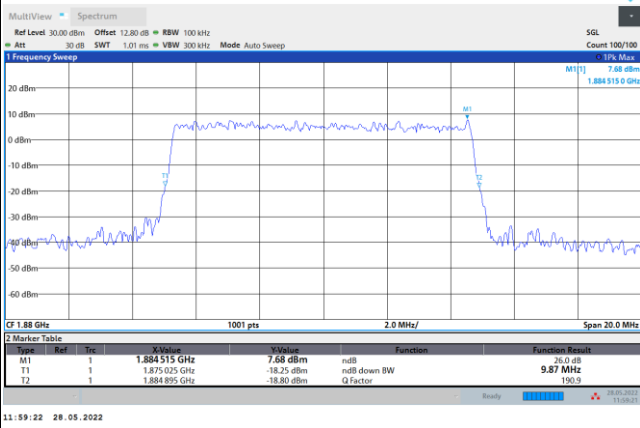



FR1 n2 / 15MHz / DFT-S OFDM / Middle Channel / Full RB

PI/2 BPSK

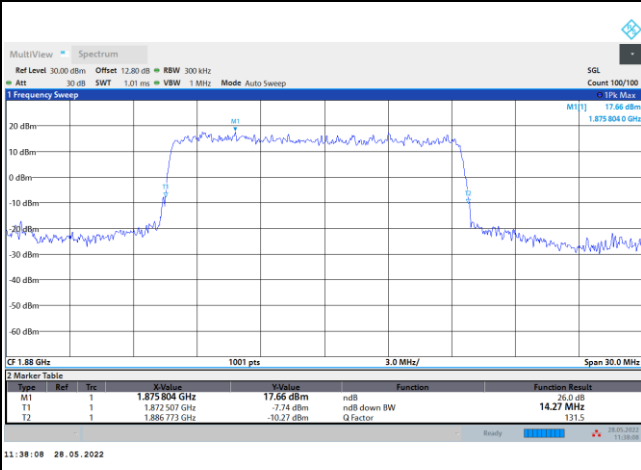

FR1 n2 / 15MHz / CP OFDM / Middle Channel / Full RB

QPSK

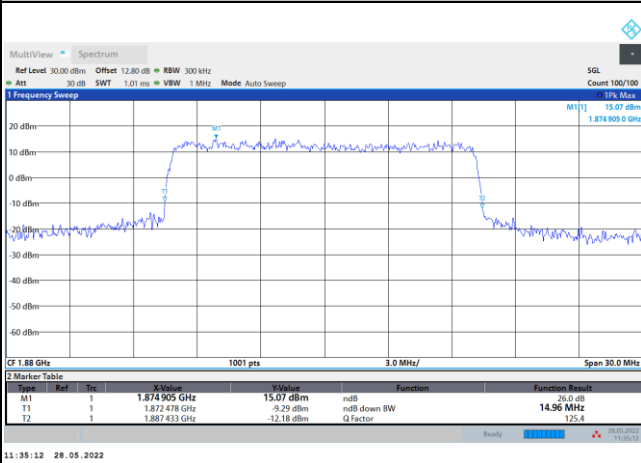

16QAM

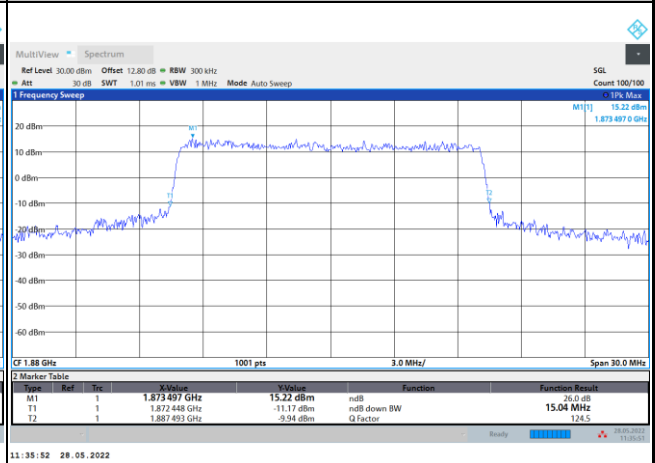

64QAM

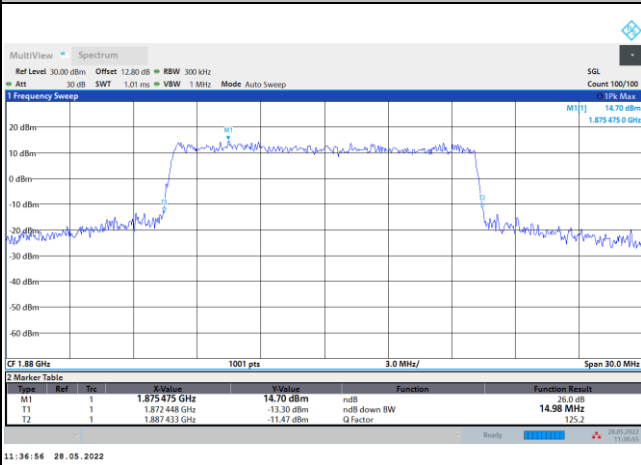

256QAM

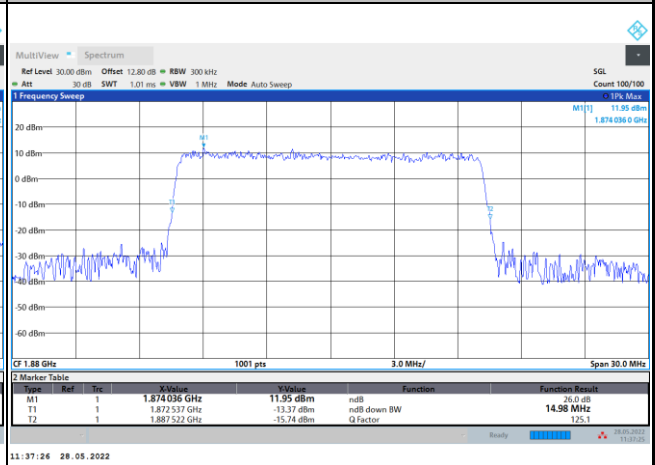



FR1 n2 / 20MHz / DFT-S OFDM / Middle Channel / Full RB

PI/2 BPSK

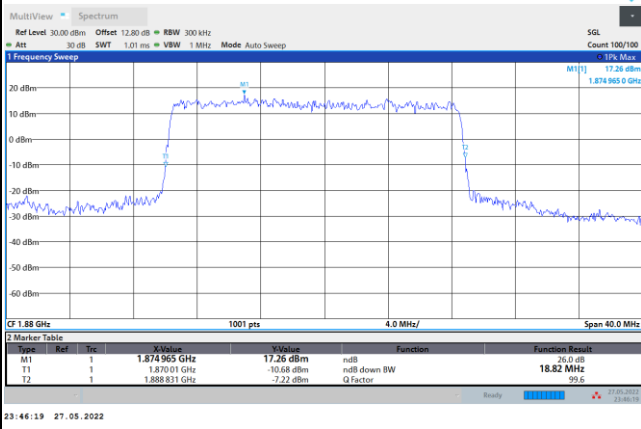

FR1 n2 / 20MHz / CP OFDM / Middle Channel / Full RB

QPSK

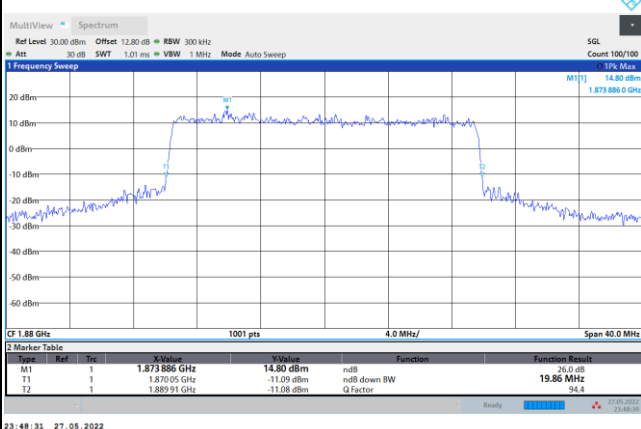

16QAM

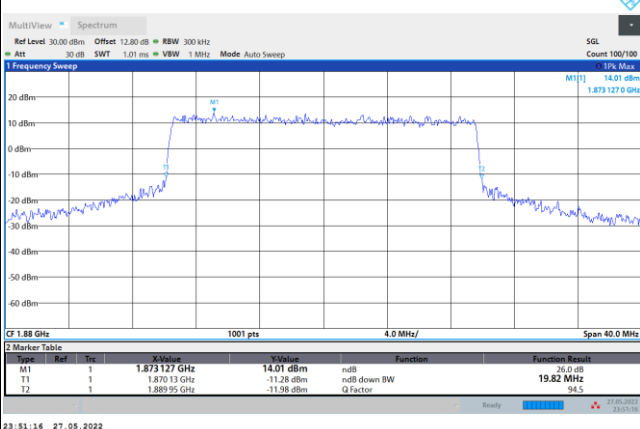

64QAM

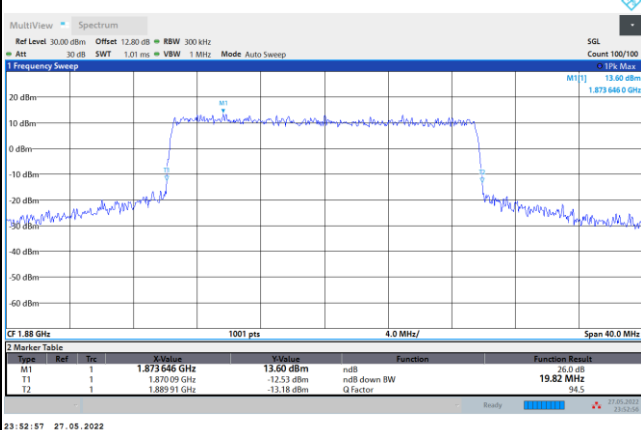

256QAM

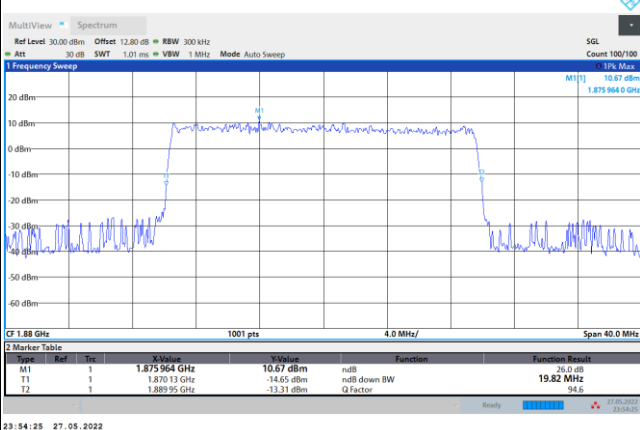



Occupied Bandwidth

Mode	FR1 n2 : 99%OBW(MHz) / DFT-S OFDM							
BW	5MHz		10MHz		15MHz		20MHz	
Mod.	PI/2 BPSK		PI/2 BPSK		PI/2 BPSK		PI/2 BPSK	
Middle CH	4.46		8.91		13.48		17.92	

Mode	FR1 n2 : 99%OBW (MHz) / CP OFDM							
BW	5MHz		10MHz		15MHz		20MHz	
Mod.	QPSK	16QAM	QPSK	16QAM	QPSK	16QAM	QPSK	16QAM
Middle CH	4.49	4.52	9.29	9.29	14.14	14.15	18.95	18.91
Mod.	64QAM	256QAM	64QAM	256QAM	64QAM	256QAM	64QAM	256QAM
Middle CH	4.49	4.49	9.30	9.30	14.19	14.13	18.96	18.96



FR1 n2 / 5MHz / DFT-S OFDM / Middle Channel / Full RB

PI/2 BPSK

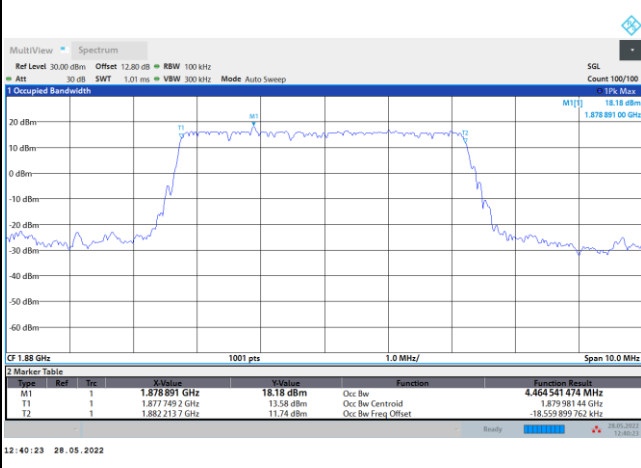

FR1 n2 / 5MHz / CP OFDM / Middle Channel / Full RB

QPSK

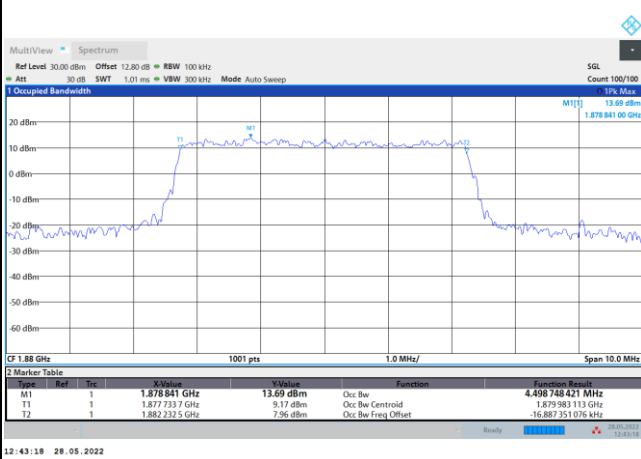

16QAM

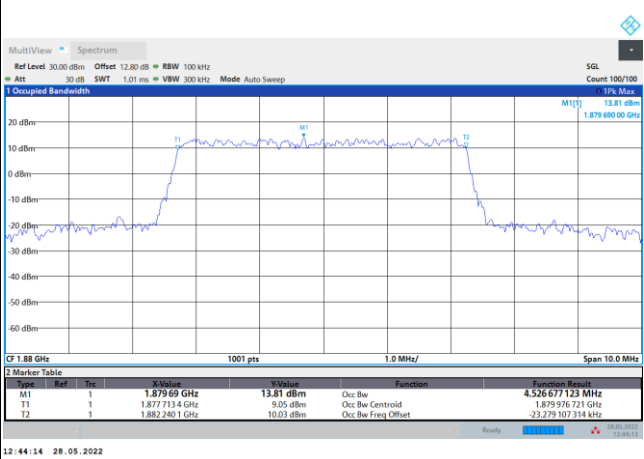

64QAM

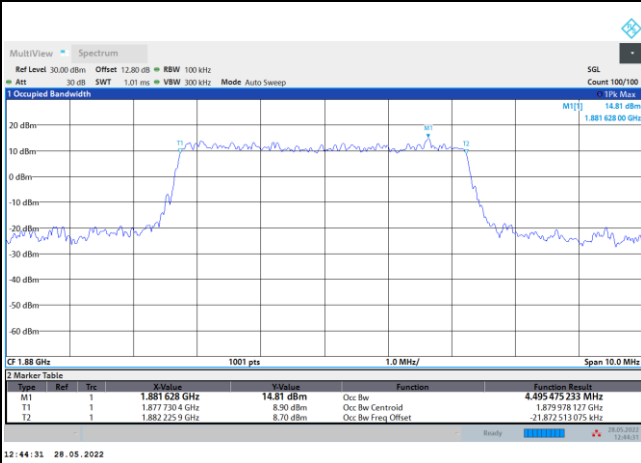

256QAM

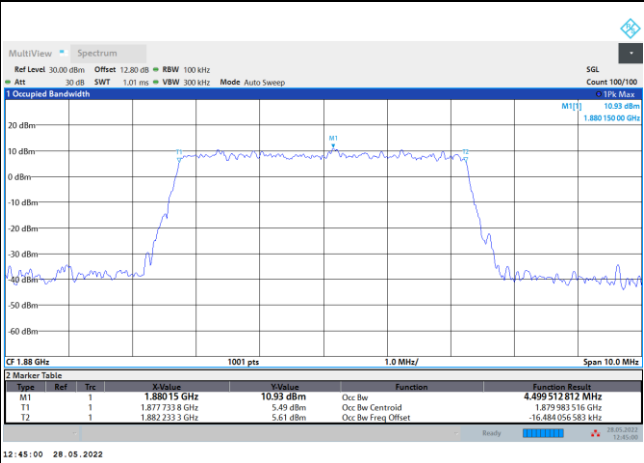



FR1 n2 / 10MHz / DFT-S OFDM / Middle Channel / Full RB

PI/2 BPSK

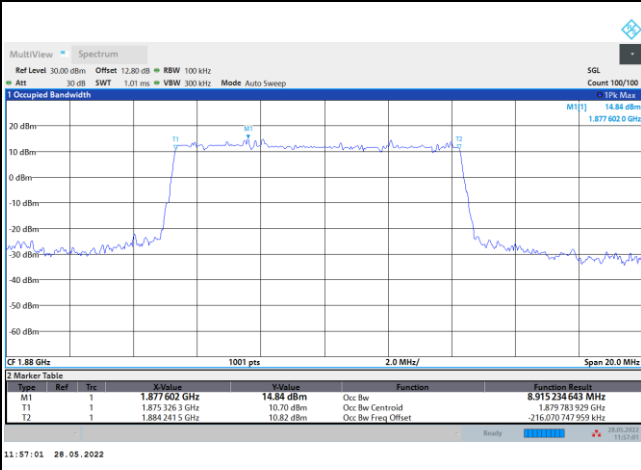

FR1 n2 / 10MHz / CP OFDM / Middle Channel / Full RB

QPSK

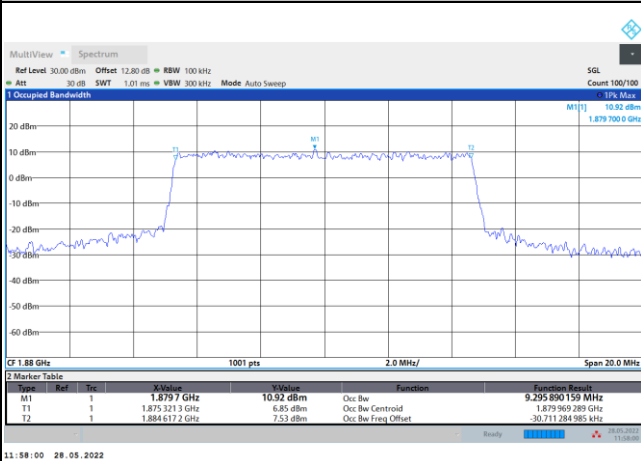

16QAM

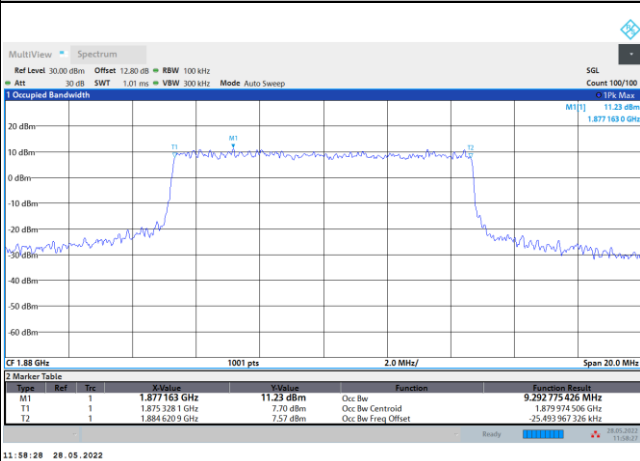

64QAM

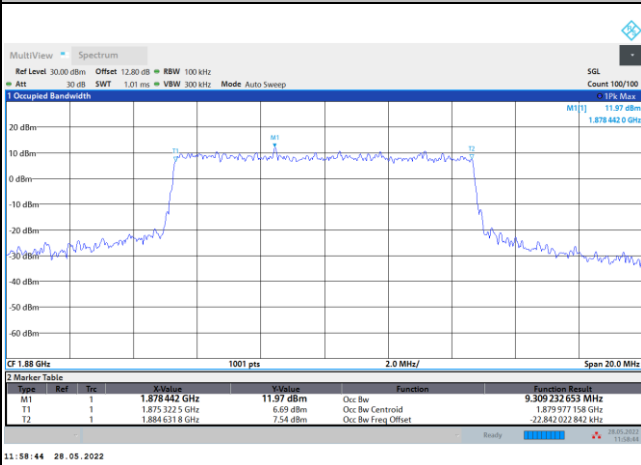

256QAM

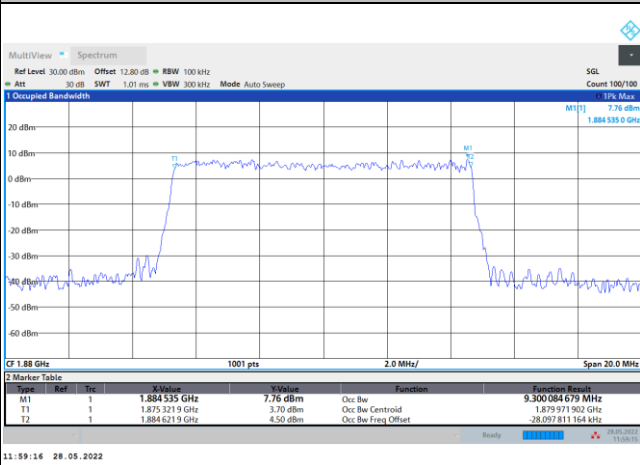



FR1 n2 / 15MHz / DFT-S OFDM / Middle Channel / Full RB

PI/2 BPSK

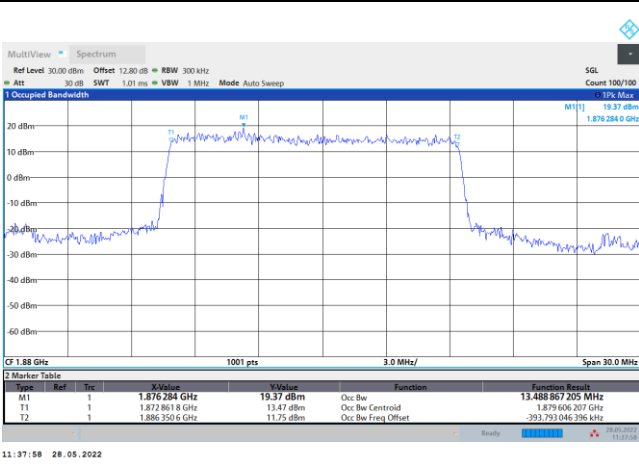

FR1 n2 / 15MHz / CP OFDM / Middle Channel / Full RB

QPSK

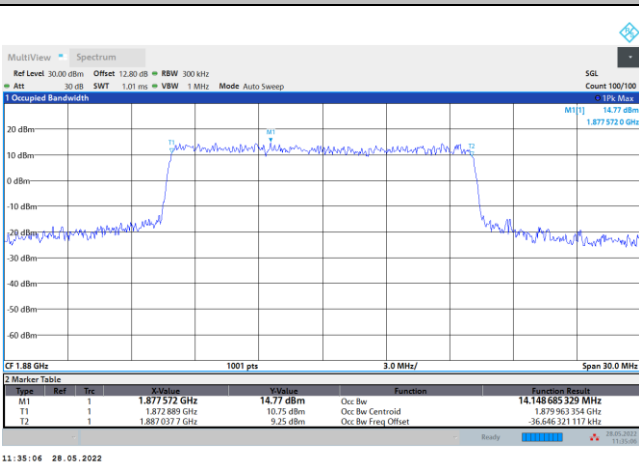

16QAM

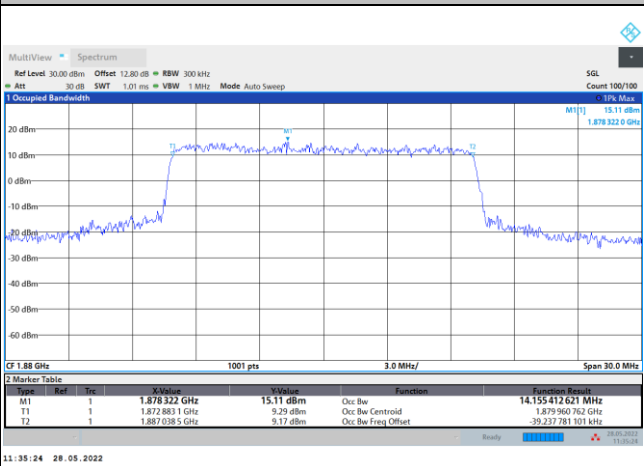

64QAM

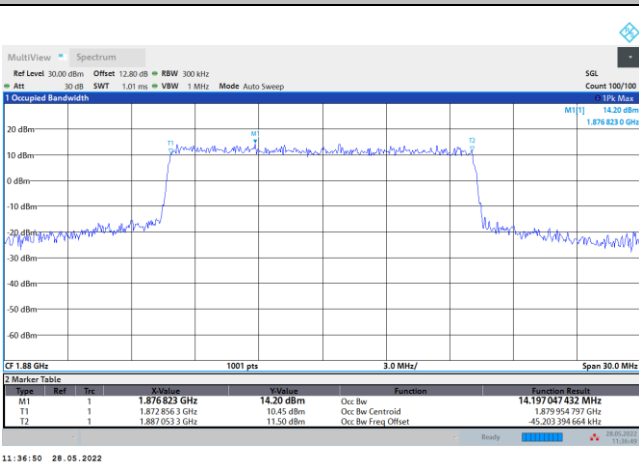

256QAM

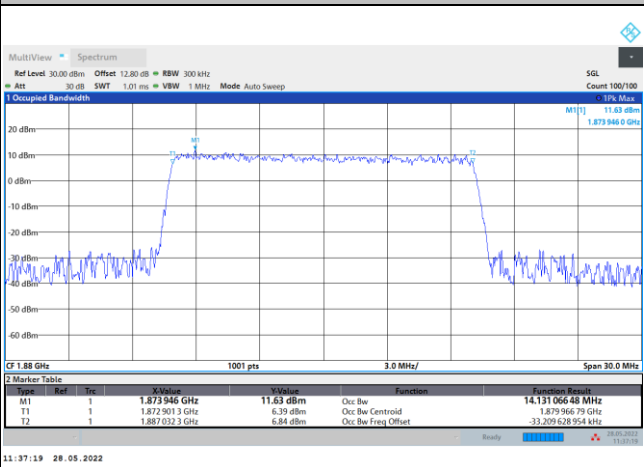



FR1 n2 / 20MHz / DFT-S OFDM / Middle Channel / Full RB

PI/2 BPSK

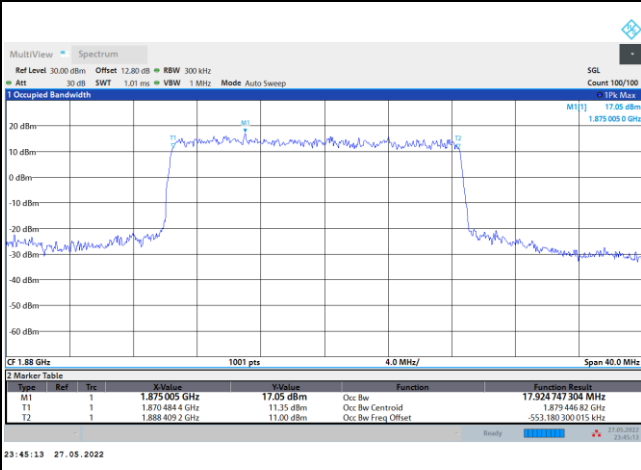

FR1 n2 / 20MHz / CP OFDM / Middle Channel / Full RB

QPSK

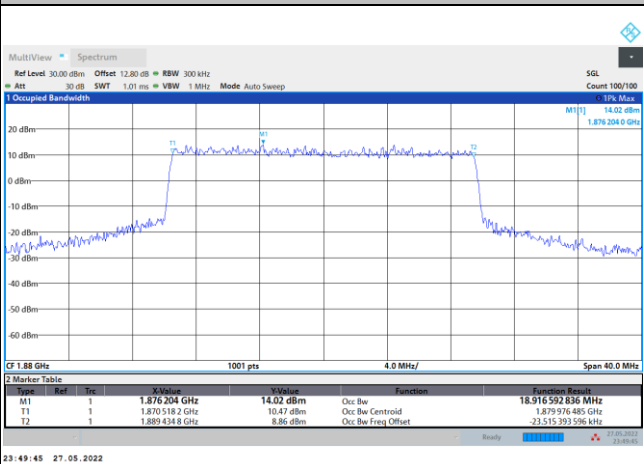
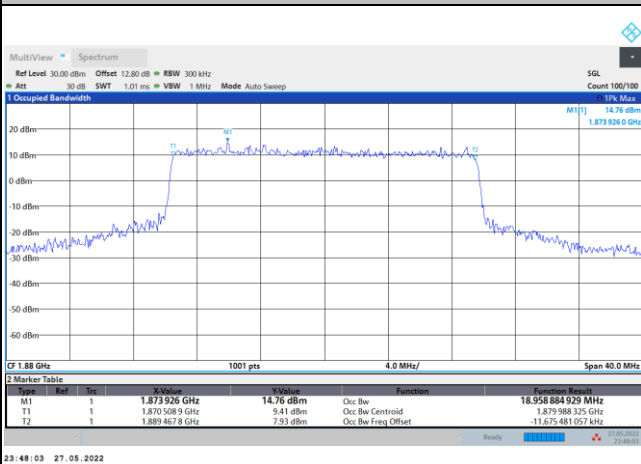

64QAM

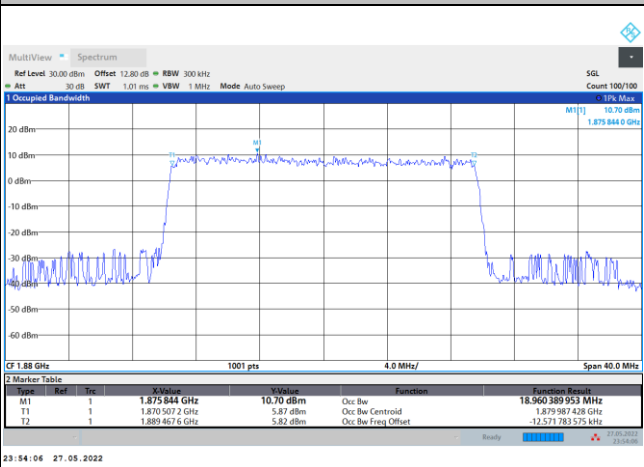
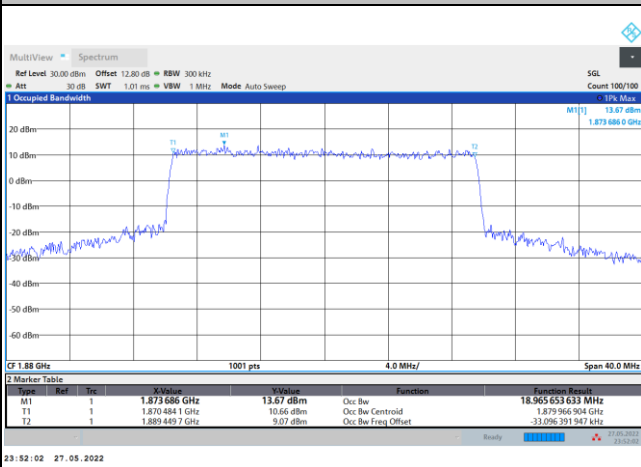

256QAM



Conducted Band Edge

FR1 n2 / 5MHz / DFT-S OFDM / PI/2 BPSK

Lowest Band Edge / 1RB0

Highest Band Edge / 1RBmax

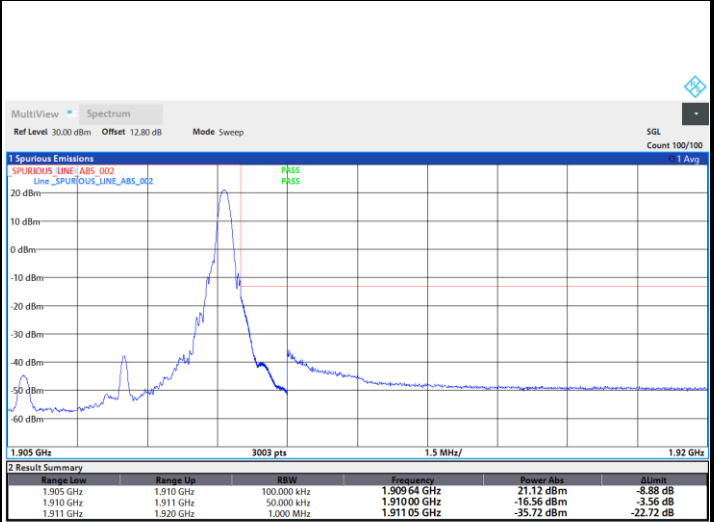
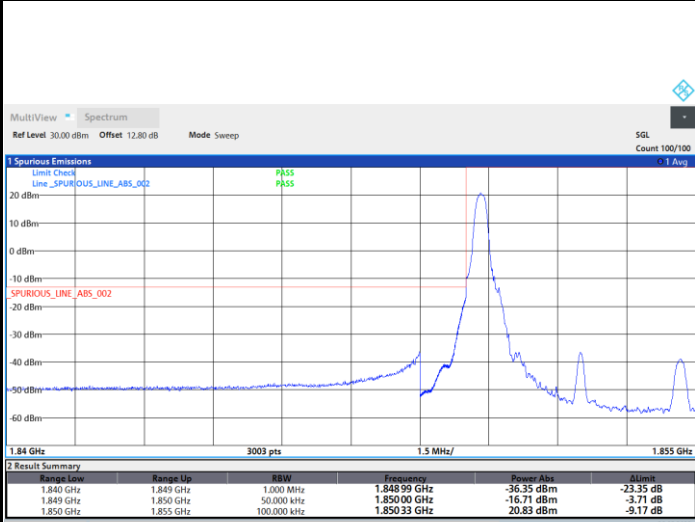

12:18:26 28.05.2022

12:50:53 28.05.2022

Lowest Band Edge / Full RB

Highest Band Edge / Full RB

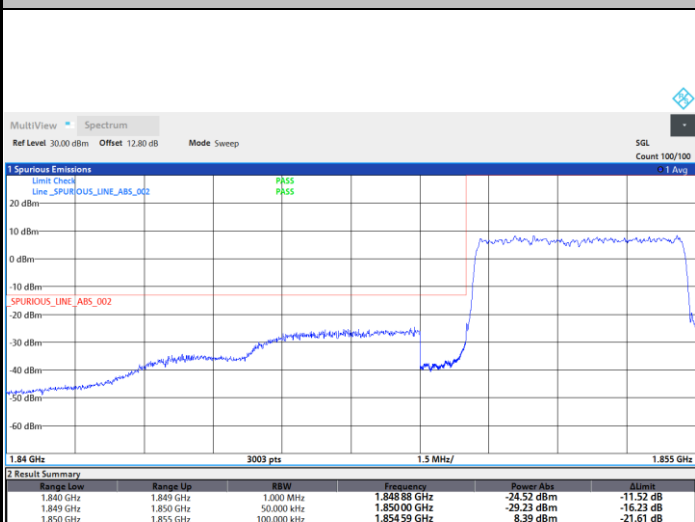

12:09:08 28.05.2022

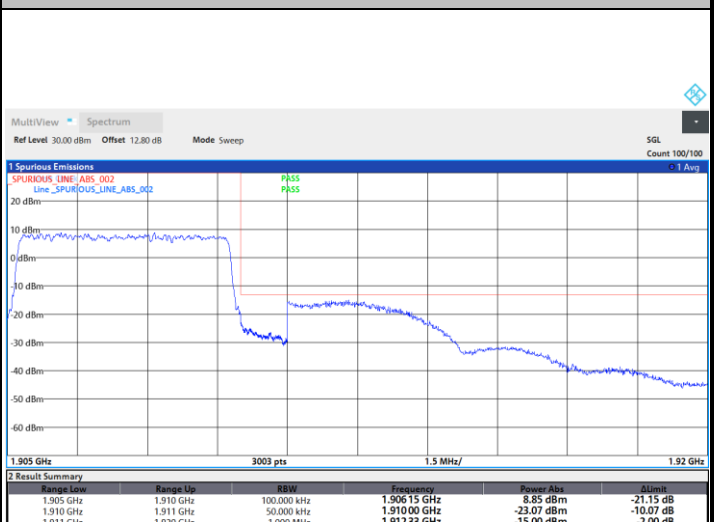

12:46:54 28.05.2022



FR1 n2 / 5MHz / DFT-S OFDM / QPSK

Lowest Band Edge / 1RB0

Highest Band Edge / 1RBmax

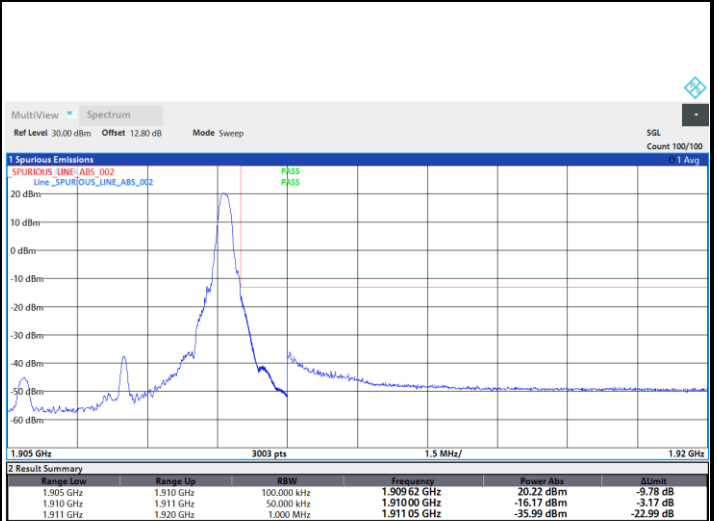
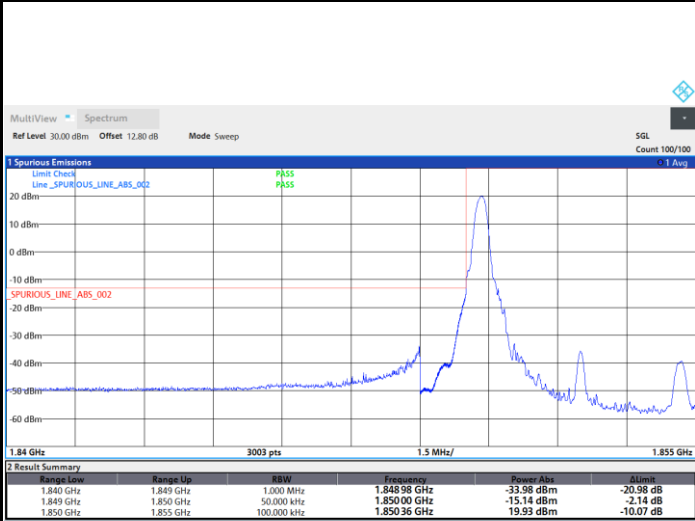

12:20:04 28.05.2022

12:50:32 28.05.2022

Lowest Band Edge / Full RB

Highest Band Edge / Full RB

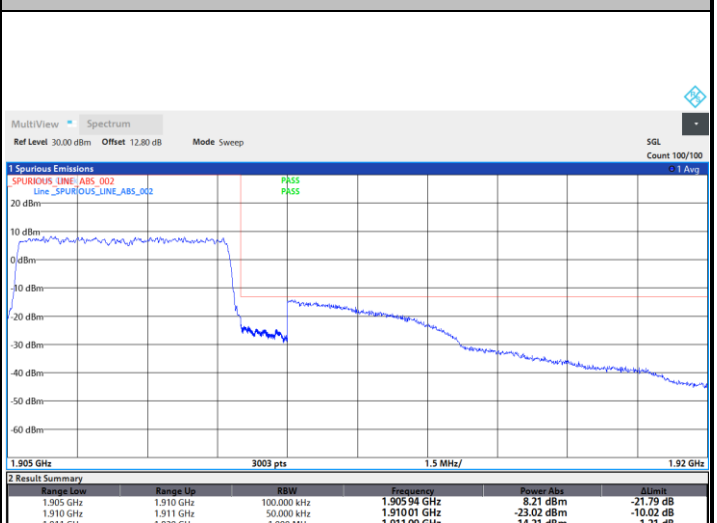
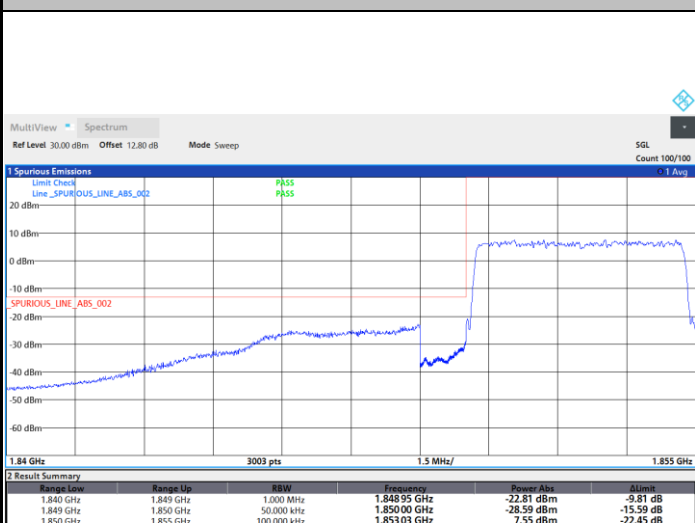

12:09:27 28.05.2022

12:48:23 28.05.2022



FR1 n2 / 5MHz / DFT-S OFDM / 16QAM

Lowest Band Edge / 1RB0

Highest Band Edge / 1RBmax

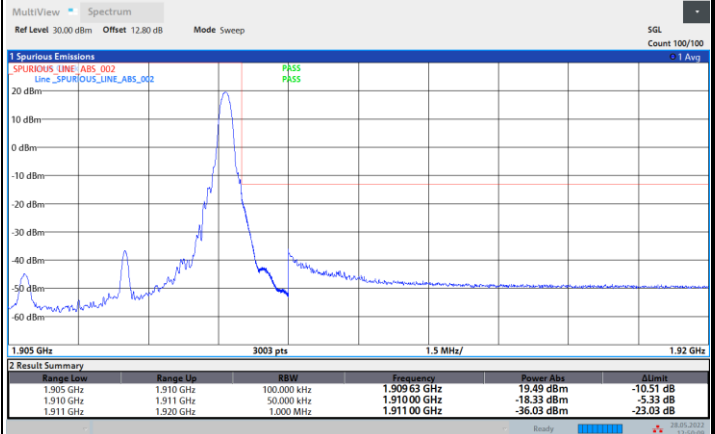
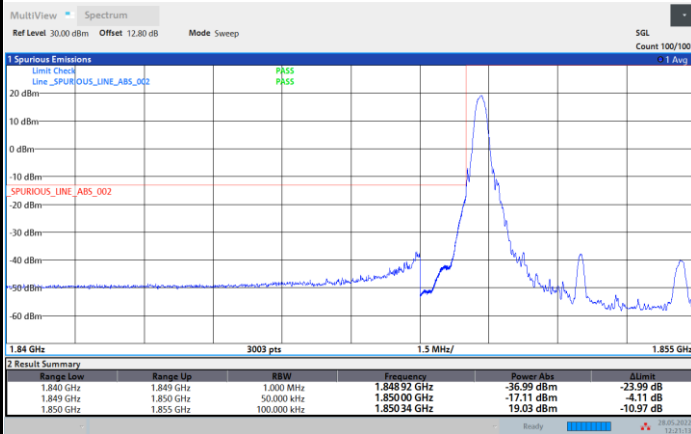

Lowest Band Edge / Full RB

Highest Band Edge / Full RB

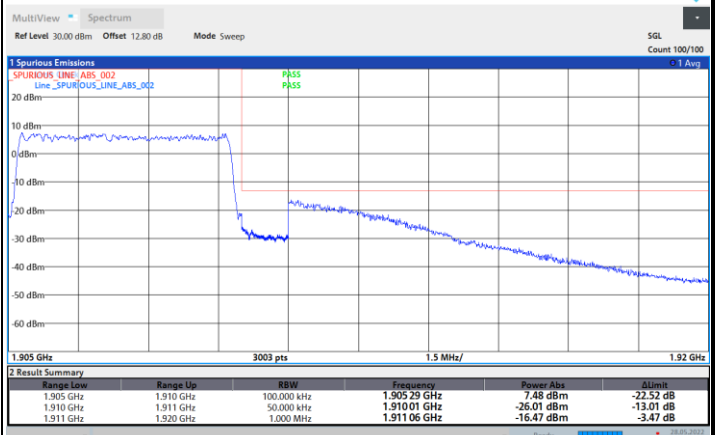
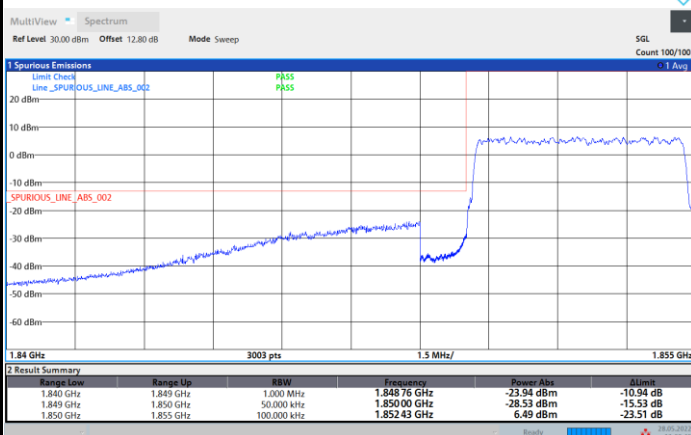



FR1 n2 / 5MHz / DFT-S OFDM / 64QAM

Lowest Band Edge / 1RB0

Highest Band Edge / 1RBmax

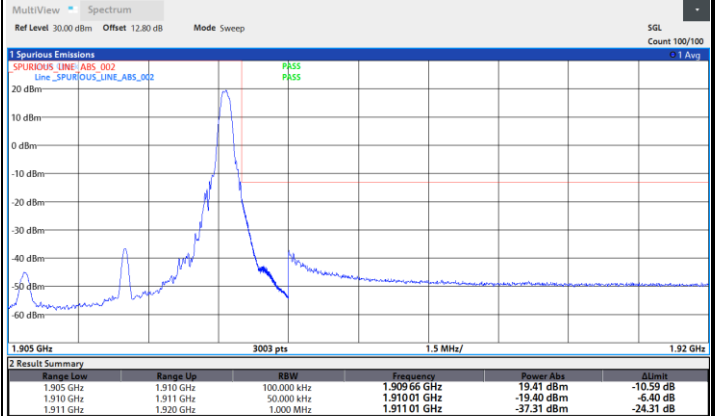
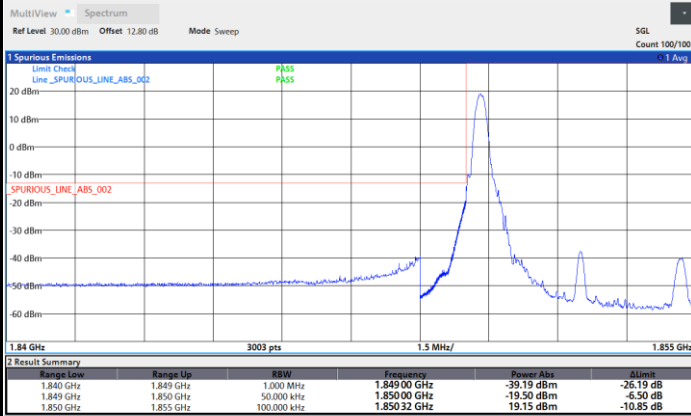

Lowest Band Edge / Full RB

Highest Band Edge / Full RB

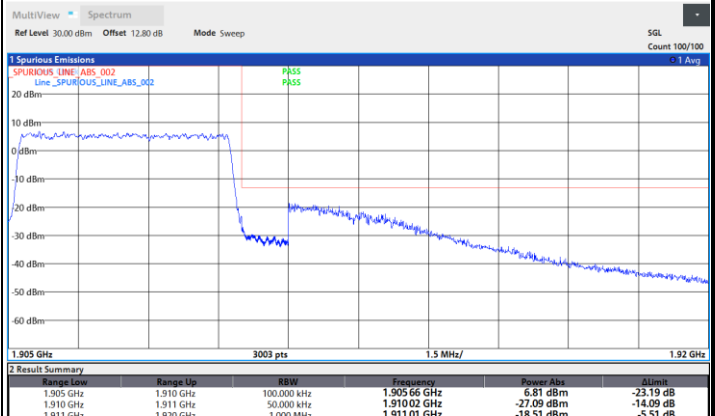
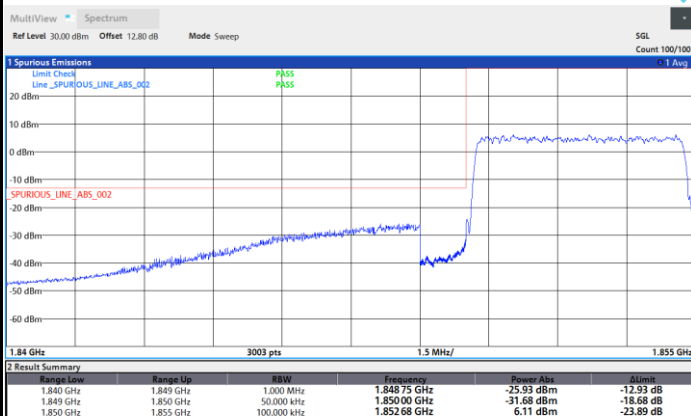



FR1 n2 / 5MHz / DFT-S OFDM / 256QAM

Lowest Band Edge / 1RB0

Highest Band Edge / 1RBmax

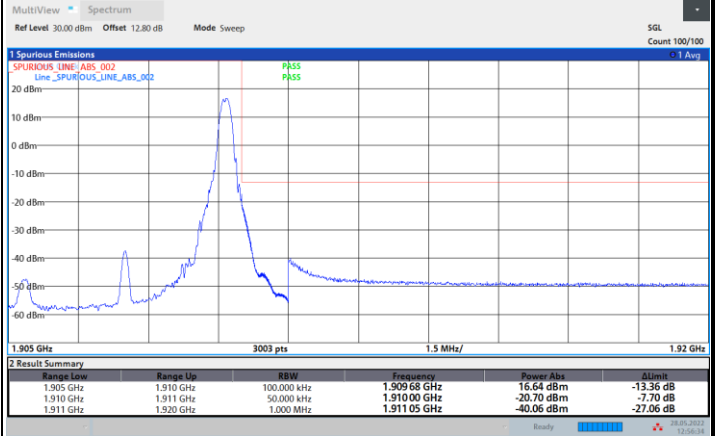
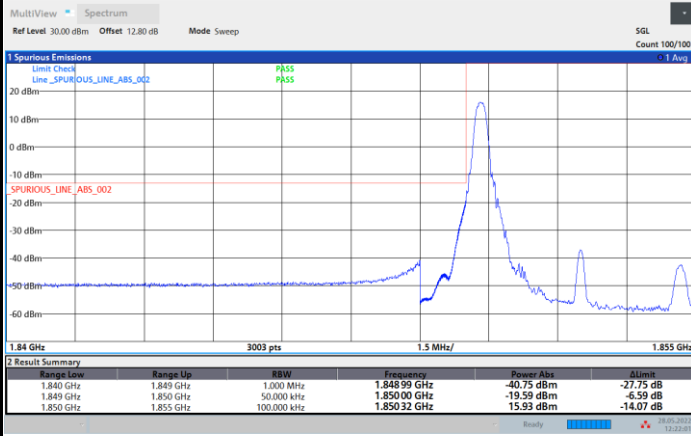

12:22:01 28.05.2022

12:56:34 28.05.2022

Lowest Band Edge / Full RB

Highest Band Edge / Full RB

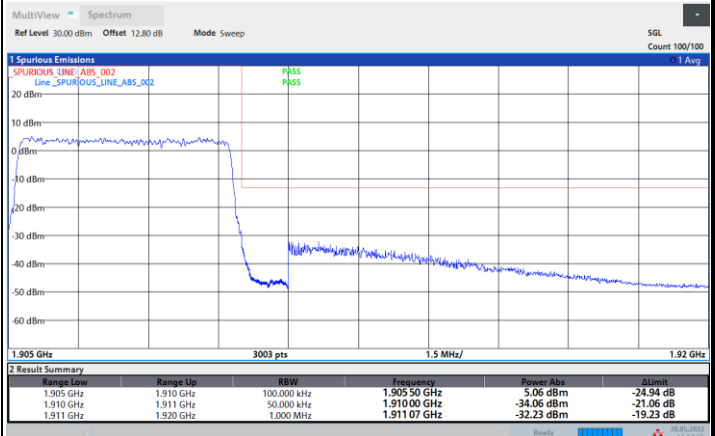
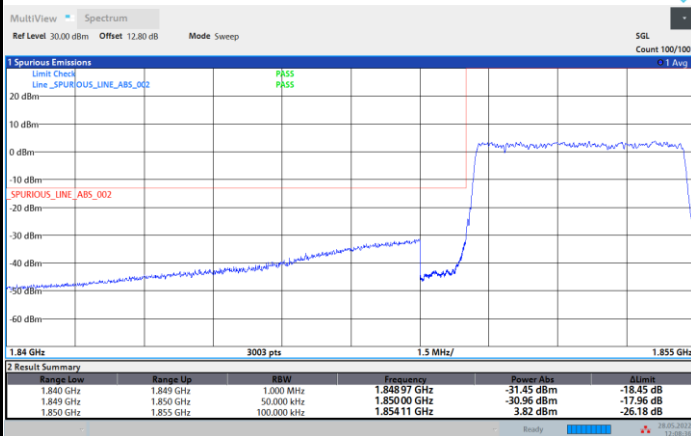

12:08:36 28.05.2022

12:57:16 28.05.2022



FR1 n2 / 5MHz / CP OFDM / QPSK / Full RB

Lowest Band Edge

Highest Band Edge

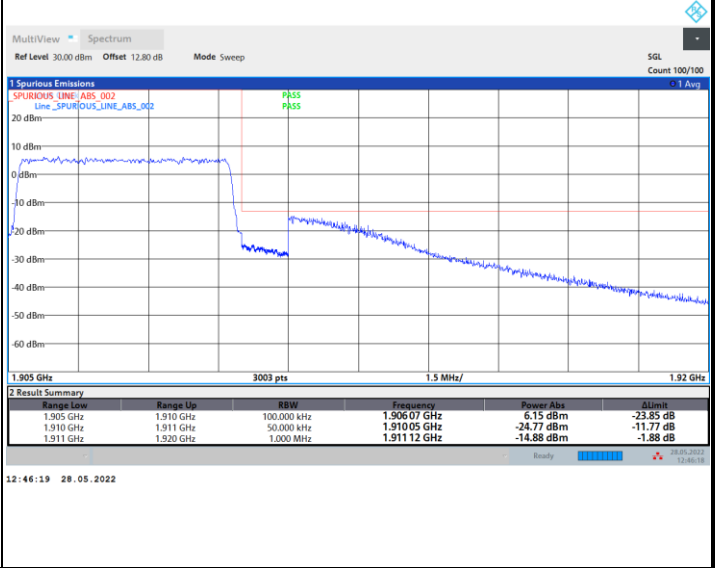
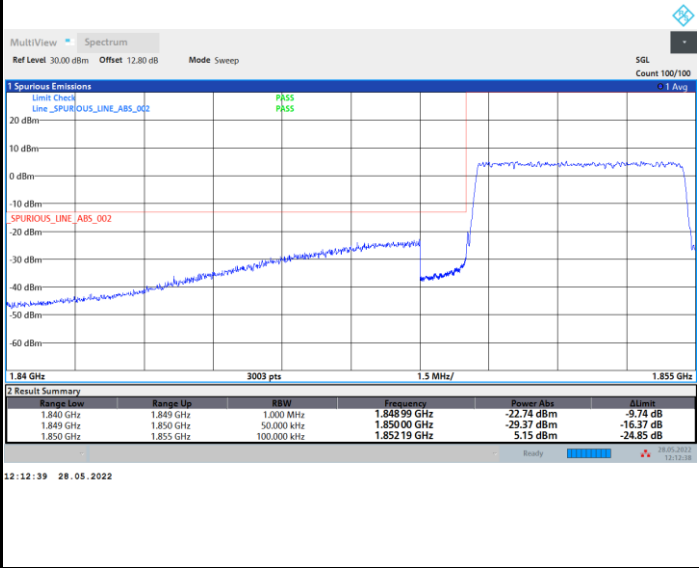



FR1 n2 / 10MHz / DFT-s-OFDM / PI/2 BPSK / Full RB

Lowest Band Edge

Highest Band Edge

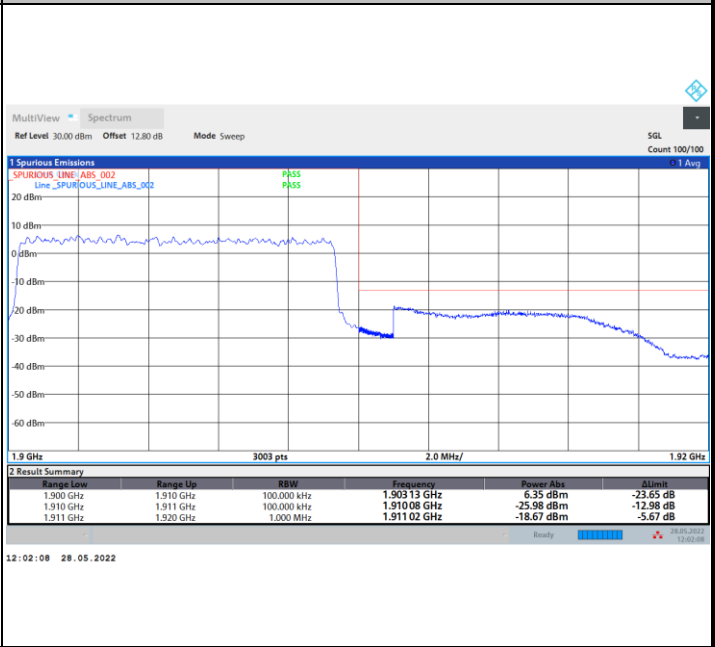
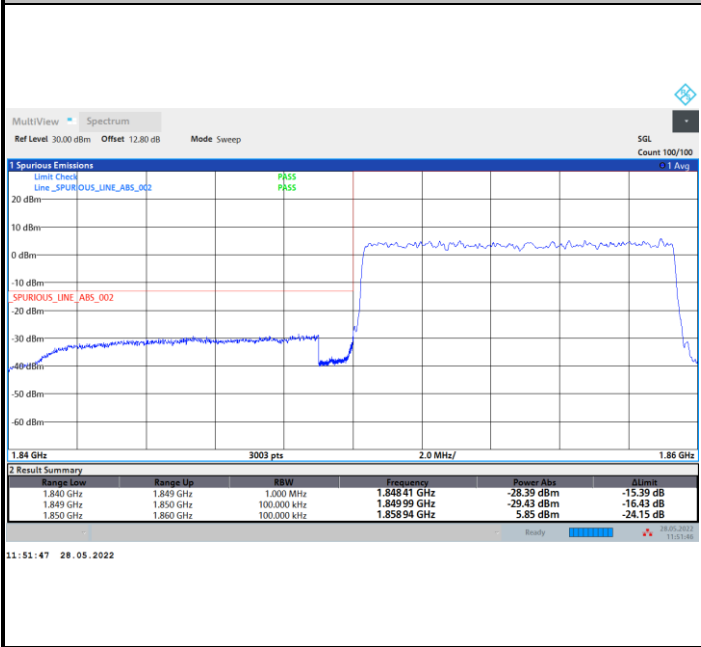

FR1 n2 / 10MHz / DFT-s-OFDM / QPSK / Full RB

Lowest Band Edge

Highest Band Edge

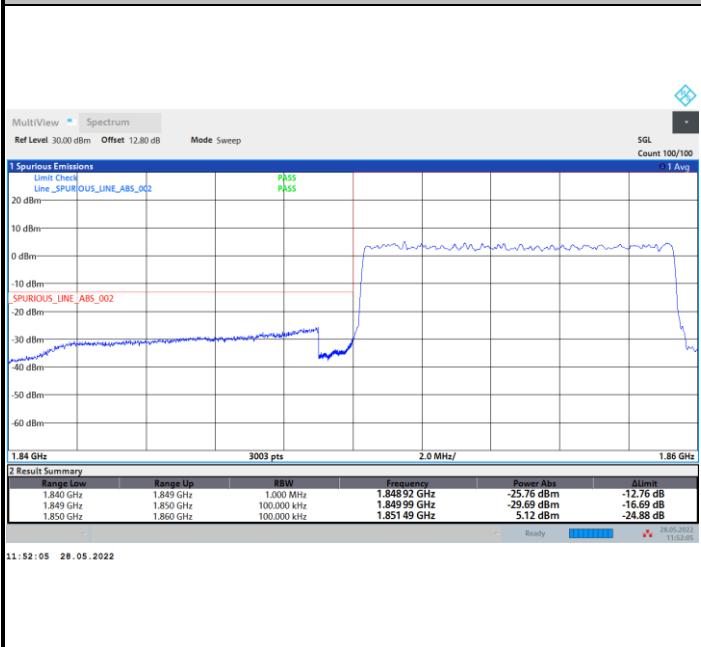



FR1 n2 / 10MHz / DFT-s-OFDM / 16QAM / Full RB

Lowest Band Edge

Highest Band Edge

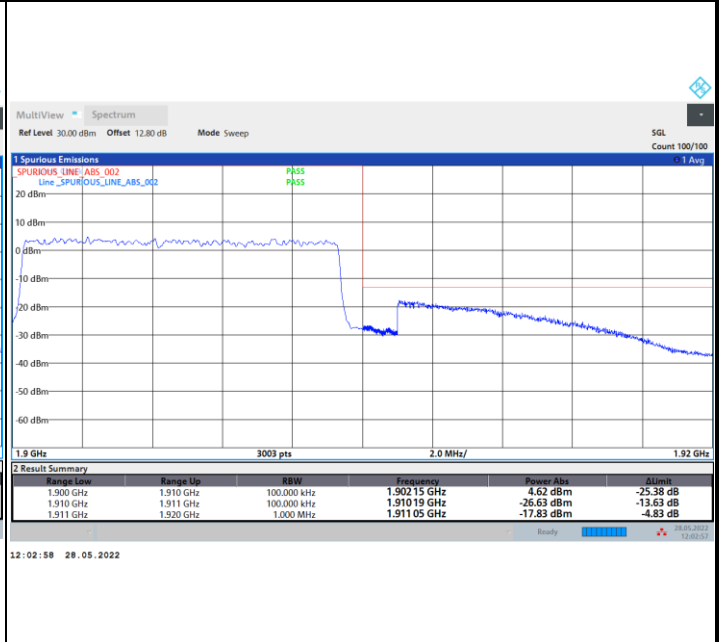
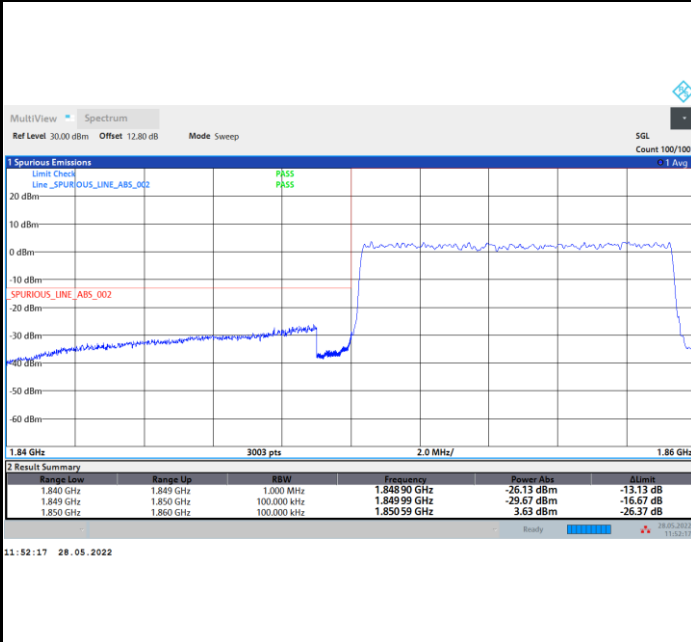

FR1 n2 / 10MHz / DFT-s-OFDM / 64QAM / Full RB

Lowest Band Edge

Highest Band Edge

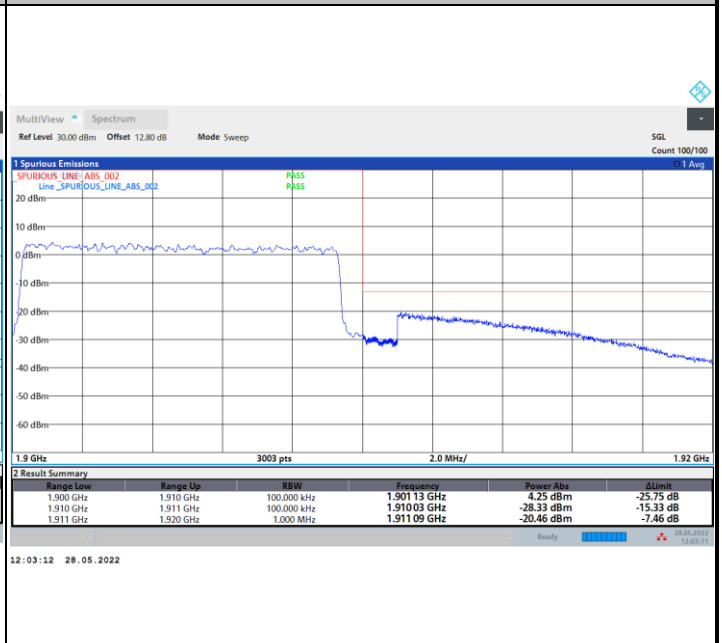
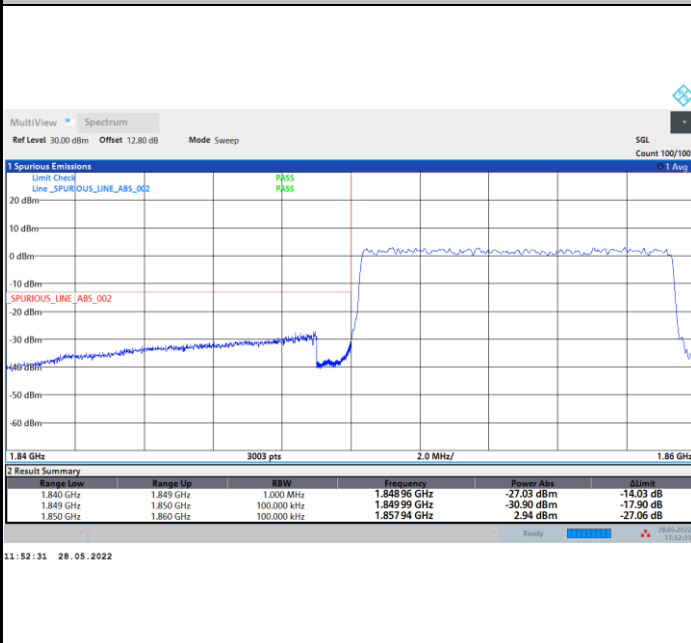



FR1 n2 / 10MHz / DFT-s-OFDM / 256QAM / Full RB

Lowest Band Edge

Highest Band Edge

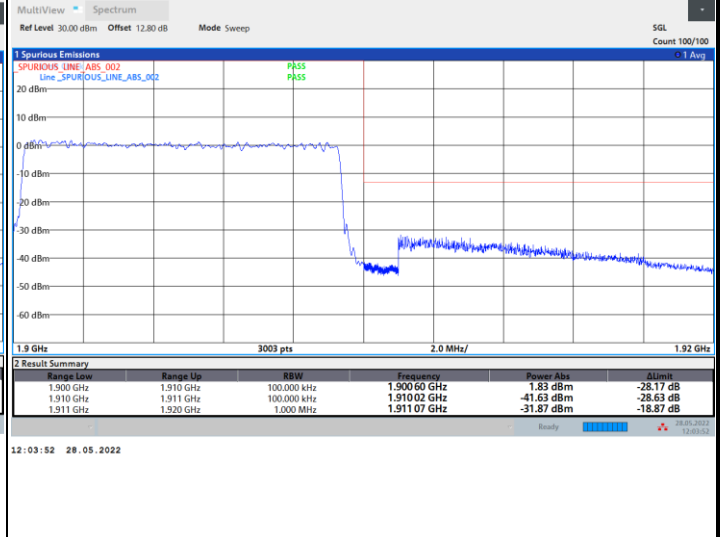
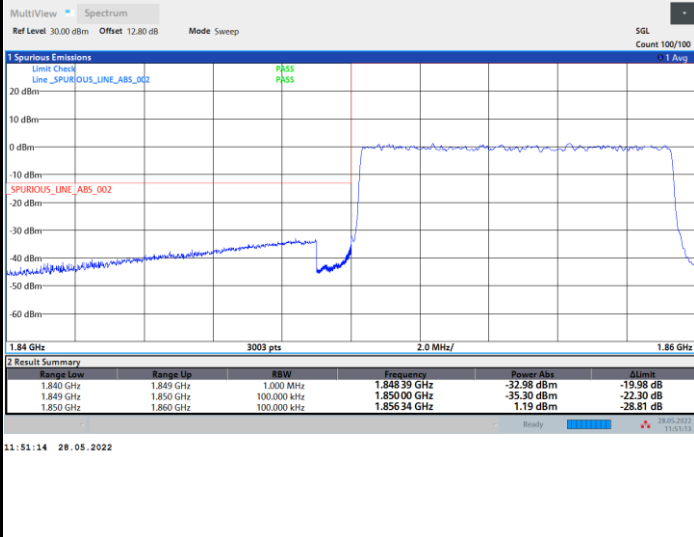

FR1 n2 / 10MHz / CP OFDM / QPSK / Full RB

Lowest Band Edge

Highest Band Edge

