



FCC RADIO TEST REPORT

FCC ID : UZ7TC58A1
Equipment : Touch Computer
Brand Name : Zebra
Model Name : TC58A1
Applicant : Zebra Technologies Corporation
1 Zebra Plaza, Holtsville, NY 11742
Manufacturer : Zebra Technologies Corporation
1 Zebra Plaza, Holtsville, NY 11742
Standard : FCC Part 15 Subpart E §15.407

The product was received on Feb. 21, 2022 and testing was performed from Mar. 01, 2022 to Aug. 11, 2022. We, Sporton International Inc. EMC & Wireless Communications Laboratory, would like to declare that the tested sample has been evaluated in accordance with the test procedures and has been in compliance with the applicable technical standards.

The test results in this report apply exclusively to the tested model / sample. Without written approval from Sporton International Inc. EMC & Wireless Communications Laboratory, the test report shall not be reproduced except in full.

Approved by: Louis Wu

Sporton International Inc. EMC & Wireless Communications Laboratory
No. 52, Huaya 1st Rd., Guishan Dist., Taoyuan City 333, Taiwan (R.O.C.)



Table of Contents

History of this test report.....	3
Summary of Test Result.....	4
1 General Description	5
1.1 Product Feature of Equipment Under Test.....	5
1.2 Product Specification of Equipment Under Test.....	6
1.3 Modification of EUT	12
1.4 Testing Location	13
1.5 Applicable Standards.....	13
2 Test Configuration of Equipment Under Test	14
2.1 Carrier Frequency and Channel	14
2.2 Test Mode.....	17
2.3 Connection Diagram of Test System.....	33
2.4 Support Unit used in test configuration and system	34
2.5 EUT Operation Test Setup	34
2.6 Measurement Results Explanation Example.....	35
3 Test Result	36
3.1 26dB & 99% Occupied Bandwidth Measurement	36
3.2 Fundamental Maximum EIRP Measurement	49
3.3 Fundamental Power Spectral Density Measurement.....	83
3.4 In-Band Emissions (Channel Mask)	121
3.5 Contention Based Protocol.....	219
3.6 Unwanted Emissions Measurement.....	242
3.7 AC Conducted Emission Measurement.....	247
3.8 Antenna Requirements.....	249
4 List of Measuring Equipment.....	253
5 Uncertainty of Evaluation	255
Appendix A. AC Conducted Emission Test Result	
Appendix B. Radiated Spurious Emission	
Appendix C. Radiated Spurious Emission Plots	
Appendix D. Duty Cycle Plots	
Appendix E. Setup Photographs	



History of this test report

Report No.	Version	Description	Issue Date
FR222202G	01	Initial issue of report	Jun. 17, 2022
FR222202G	02	<ol style="list-style-type: none"> 1. Add Partial RU Mask data 2. Revise List of Measuring Equipment 	Jun. 24, 2022
FR222202G	03	<ol style="list-style-type: none"> 1. Revise antenna information 2. Add test items information at page 12 	Jul. 27, 2022
FR222202G	04	<ol style="list-style-type: none"> 1. Revise Product Specification of Equipment Under Test 2. Revise Test Result of Power Spectral Density 3. Revise note of section 3.5.6 4. Revise Antenna Requirements 	Aug. 04, 2022
FR222202G	05	<ol style="list-style-type: none"> 1. Add antenna brand name and model name 2. Add TXBF mode data in section 3.3.5 and section 3.4.5 3. Revise section 2.2, section 3.2.5 and antenna gain for SDM mode 4. Revise description of test mode 	Aug. 11, 2022



Summary of Test Result

Report Clause	Ref Std. Clause	Test Items	Result (PASS/FAIL)	Remark
3.1	15.403(i) 15.407(a)(10)	26dB Emission Bandwidth	Pass	-
3.1	2.1049	99% Occupied Bandwidth	Reporting only	-
3.2	15.407(a)(8)	Fundamental Maximum EIRP	Pass	-
3.3	15.407(a)(8)	Fundamental Power Spectral Density	Pass	-
3.4	15.407(b)(6)	In-Band Emissions (Channel Mask)	Pass	-
3.5	15.407(d)(6)	Contention Based Protocol	Pass	-
3.6	15.407(b)	Unwanted Emissions	Pass	1.15 dB under the limit at 5924.960 MHz
3.7	15.207	AC Conducted Emission	Pass	17.51 dB under the limit at 0.258 MHz
3.8	15.203 15.407(a)	Antenna Requirement	Pass	-

Declaration of Conformity:

1. The test results (PASS/FAIL) with all measurement uncertainty excluded are presented in accordance with the regulation limits or requirements declared by manufacturers.
It's means measurement values may risk exceeding the limit of regulation standards, if measurement uncertainty is include in test results.
2. The measurement uncertainty please refer to this report "Uncertainty of Evaluation".

Comments and Explanations:

The product specifications of the EUT presented in the report are declared by the manufacturer who shall take full responsibility for the authenticity.

Reviewed by: Wei Chen

Report Producer: Vivian Hsu



1 General Description

1.1 Product Feature of Equipment Under Test

Product Feature	
Equipment	Touch Computer
Brand Name	Zebra
Model Name	TC58A1
FCC ID	UZ7TC58A1
Sample 1	Lowell + Premium config
Sample 2	SE4720 + Base config
Sample 3	Lowell + Base config
EUT supports Radios application	GSM/EGPRS/WCDMA/HSPA/LTE/5G NR/NFC/GNSS WLAN 11a/b/g/n HT20/HT40 WLAN 11ac VHT20/VHT40/VHT80/VHT160 WLAN 11ax HE20/HE40/HE80/HE160 Bluetooth BR/EDR/LE
HW Version	EV3
SW Version	athena_A11_userdebug_GMS_RelKey_2022-02-22-2145_p roduct_SE
FW Version	FUSION_QA_4_1.0.0.013_R
MFD	19FEB22
EUT Stage	Identical Prototype

Remark: The above EUT's information was declared by manufacturer.

Specification of Accessories				
Adapter	Brand Name	Zebra	Part Number	PWR-WUA5V12W0US
Battery 1X	Brand Name	Zebra	Part Number	BT-000442-0020
Battery 1.5X	Brand Name	Zebra	Part Number	BT-000442-0820
USB TYPE A to TYPE C cable	Brand Name	Zebra	Part Number	CBL-TC5X-USBC2A-01
USB TYPE C to 3.5mm audio connector	Brand Name	Zebra	Part Number	ADP-USBC-35MM1-01
3.5mm Earphone	Brand Name	Zebra	Part Number	HDST-35MM-PTVP-01
USB TYPE C Earphone	Brand Name	Zebra	Part Number	HPST-USBC-PTT1-01
Headset Jumper	Brand Name	Zebra	Part Number	CBL-TC51-HDST35-01
Trigger Handle	Brand Name	Zebra	Part Number	TRG-NGTC5-ELEC-01
Soft Holster	Brand Name	Zebra	Part Number	SG-NGTC5TC7-HLSTR-01
TC53/TC58 RUGGED BOOT	Brand Name	Zebra	Part Number	SG-NGTC5EXO1-01



1.2 Product Specification of Equipment Under Test

Product Specification is subject to this standard	
Tx/Rx Frequency Range	5925 MHz ~ 6425 MHz 6425 MHz ~ 6525 MHz 6525 MHz ~ 6875 MHz 6875 MHz ~ 7125 MHz
Maximum Output Power to Antenna <SDM Mode>	<p><Indoor Client> MIMO <Ant. 9+8> <UNII-5> 802.11n HT20: 7.71 dBm / 0.0059 W 802.11n HT40: 10.37 dBm / 0.0109 W 802.11ac VHT20: 7.71 dBm / 0.0059 W 802.11ac VHT40: 10.37 dBm / 0.0109 W 802.11ac VHT80: 13.41 dBm / 0.0219 W 802.11ac VHT160: 15.31 dBm / 0.0340 W 802.11ax HE20: 7.81 dBm / 0.0060 W 802.11ax HE40: 10.47 dBm / 0.0111 W 802.11ax HE80: 13.51 dBm / 0.0224 W 802.11ax HE160: 15.41 dBm / 0.0348 W</p> <p><UNII-6> 802.11n HT20: 7.51 dBm / 0.0056 W 802.11n HT40: 10.51 dBm / 0.0112 W 802.11ac VHT20: 7.51 dBm / 0.0056 W 802.11ac VHT40: 10.51 dBm / 0.0112 W 802.11ac VHT80: 13.26 dBm / 0.0212 W 802.11ac VHT160: 15.11 dBm / 0.0324 W 802.11ax HE20: 7.61 dBm / 0.0058W 802.11ax HE40: 10.46 dBm / 0.0111 W 802.11ax HE80: 13.36 dBm / 0.0217 W 802.11ax HE160:14.87 dBm / 0.0307 W</p> <p><UNII-7> 802.11n HT20: 7.52 dBm / 0.0056 W 802.11n HT40: 10.36 dBm / 0.0109 W 802.11ac VHT20: 7.52 dBm / 0.0056 W 802.11ac VHT40: 10.36 dBm / 0.0109 W 802.11ac VHT80: 13.27 dBm / 0.0212 W 802.11ac VHT160: 14.66 dBm / 0.0292 W 802.11ax HE20: 7.62 dBm / 0.0058 W 802.11ax HE40: 10.46 dBm / 0.0111 W 802.11ax HE80: 13.37 dBm / 0.0217 W 802.11ax HE160: 14.76 dBm / 0.0299 W</p>



Product Specification is subject to this standard	
Maximum Output Power to Antenna <SDM Mode>	<UNII-8>
	802.11n HT20: 8.27 dBm / 0.0067 W
	802.11n HT40: 10.62 dBm / 0.0115 W
	802.11ac VHT20: 8.27 dBm / 0.0067 W
	802.11ac VHT40: 10.62 dBm / 0.0115 W
	802.11ac VHT80: 13.57 dBm / 0.0228 W
	802.11ac VHT160: 14.47 dBm / 0.0280 W
	802.11ax HE20: 8.37 dBm / 0.0069 W
	802.11ax HE40: 10.72 dBm / 0.0118 W
	802.11ax HE80: 13.67 dBm / 0.0233 W
	802.11ax HE160: 14.57 dBm / 0.0286 W
	<Standard Client>
	MIMO <Ant. 9+8>
	<UNII-5>
	802.11n HT20: 15.26 dBm / 0.0336 W
	802.11n HT40: 15.31 dBm / 0.0340 W
	802.11ac VHT20: 15.26 dBm / 0.0336 W
	802.11ac VHT40: 15.31 dBm / 0.0340 W
	802.11ac VHT80: 15.36 dBm / 0.0344 W
	802.11ac VHT160: 15.07 dBm / 0.0321 W
	802.11ax HE20: 15.36 dBm / 0.0344 W
	802.11ax HE40: 15.41 dBm / 0.0348 W
	802.11ax HE80: 15.46 dBm / 0.0352 W
	802.11ax HE160: 15.17 dBm / 0.0329 W
	<UNII-7>
	802.11n HT20: 14.71 dBm / 0.0296 W
	802.11n HT40: 14.91 dBm / 0.0310 W
	802.11ac VHT20: 14.71 dBm / 0.0296 W
	802.11ac VHT40: 14.91 dBm / 0.0310 W
	802.11ac VHT80: 14.86 dBm / 0.0306 W
	802.11ac VHT160: 14.81 dBm / 0.0303 W
	802.11ax HE20: 14.81 dBm / 0.0303 W
	802.11ax HE40: 15.01 dBm / 0.0317 W
	802.11ax HE80: 14.96 dBm / 0.0313 W
	802.11ax HE160: 14.91 dBm / 0.0310 W



Product Specification is subject to this standard	
Maximum Output Power to Antenna <CDD Mode>	<Indoor Client>
	MIMO <Ant. 9+8>
	<UNII-5>
	802.11a: 3.82 dBm / 0.0024 W
	802.11n HT20: 3.97 dBm / 0.0025 W
	802.11n HT40: 7.01 dBm / 0.0050 W
	802.11ac VHT20: 3.97 dBm / 0.0025 W
	802.11ac VHT40: 7.01 dBm / 0.0050 W
	802.11ac VHT80: 9.81 dBm / 0.0096 W
	802.11ac VHT160: 12.06 dBm / 0.0161 W
	802.11ax HE20: 4.07 dBm / 0.0026 W
	802.11ax HE40: 7.11 dBm / 0.0051 W
	802.11ax HE80: 9.91 dBm / 0.0098 W
	802.11ax HE160: 12.16 dBm / 0.0164 W
	<UNII-6>
	802.11a: 3.77 dBm / 0.0024 W
	802.11n HT20: 4.17 dBm / 0.0026 W
	802.11n HT40: 7.01 dBm / 0.00525 W
	802.11ac VHT20: 4.17 dBm / 0.0026 W
	802.11ac VHT40: 7.01 dBm / 0.0050 W
	802.11ac VHT80: 10.01 dBm / 0.0100 W
	802.11ac VHT160: 11.41 dBm / 0.0138 W
	802.11ax HE20: 4.27 dBm / 0.0027 W
	802.11ax HE40: 7.11 dBm / 0.0051 W
	802.11ax HE80: 10.11 dBm / 0.0103 W
	802.11ax HE160: 11.51 dBm / 0.0142 W
	<UNII-7>
	802.11a: 3.62 dBm / 0.0023 W
	802.11n HT20: 4.01 dBm / 0.0025 W
	802.11n HT40: 7.22 dBm / 0.0053 W
	802.11ac VHT20: 4.01 dBm / 0.0025 W
	802.11ac VHT40: 7.22 dBm / 0.0053 W
	802.11ac VHT80: 9.87 dBm / 0.0097 W
	802.11ac VHT160: 11.46 dBm / 0.0140 W
	802.11ax HE20: 4.11 dBm / 0.0026 W
	802.11ax HE40: 7.32 dBm / 0.0054 W
	802.11ax HE80: 9.97 dBm / 0.0099 W
	802.11ax HE160: 11.56 dBm / 0.0143 W
	<UNII-8>
	802.11a: 3.46 dBm / 0.0022 W
802.11n HT20: 3.97 dBm / 0.0025 W	
802.11n HT40: 7.26 dBm / 0.0053 W	
802.11ac VHT20: 3.97 dBm / 0.0025 W	
802.11ac VHT40: 7.26 dBm / 0.0053 W	
802.11ac VHT80: 9.76 dBm / 0.0095 W	
802.11ac VHT160: 11.41 dBm / 0.0138 W	
802.11ax HE20: 4.07 dBm / 0.0026 W	
802.11ax HE40: 7.36 dBm / 0.0054 W	
802.11ax HE80: 9.86 dBm / 0.0097 W	
802.11ax HE160: 11.51 dBm / 0.0142 W	



Product Specification is subject to this standard	
<p>Maximum Output Power to Antenna <CDD Mode></p>	<p><Standard Client> MIMO <Ant. 9+8> <UNII-5> 802.11a: 15.41 dBm / 0.0348 W 802.11ax HE20: 12.36 dBm / 0.0172 W 802.11ax HE40: 12.41 dBm / 0.0174 W 802.11ax HE80: 12.46 dBm / 0.0176 W 802.11ax HE160: 12.17 dBm / 0.0165 W <UNII-7> 802.11a: 14.63 dBm / 0.0290 W 802.11ax HE20: 11.81 dBm / 0.0152 W 802.11ax HE40: 11.91 dBm / 0.0155 W 802.11ax HE80: 11.96 dBm / 0.0157 W 802.11ax HE160: 11.57 dBm / 0.0144 W</p>
<p>Maximum Output Power to Antenna <TXBF Mode></p>	<p><Indoor Client> MIMO <Ant. 9+8> <UNII-5> 802.11ax HE20: 3.92 dBm / 0.0025 W 802.11ax HE40: 6.82 dBm / 0.0048 W 802.11ax HE80: 9.58 dBm / 0.0091 W 802.11ax HE160: 11.94 dBm / 0.0156 W <UNII-6> 802.11ax HE20: 4.27 dBm / 0.0027 W 802.11ax HE40: 6.77 dBm / 0.0048 W 802.11ax HE80: 9.87 dBm / 0.0097 W 802.11ax HE160: 11.40 dBm / 0.0138 W <UNII-7> 802.11ax HE20: 4.21 dBm / 0.0026 W 802.11ax HE40: 7.22 dBm / 0.0053 W 802.11ax HE80: 9.84 dBm / 0.0096 W 802.11ax HE160: 11.53 dBm / 0.0142 W <UNII-8> 802.11ax HE20: 4.02 dBm / 0.0025 W 802.11ax HE40: 7.04 dBm / 0.0051 W 802.11ax HE80: 9.74 dBm / 0.0094 W 802.11ax HE160: 11.47 dBm / 0.0140 W</p>
	<p><Standard Client> MIMO <Ant. 9+8> <UNII-5> 802.11ax HE20: 12.08 dBm / 0.0161 W 802.11ax HE40: 12.24 dBm / 0.0167 W 802.11ax HE80: 12.31 dBm / 0.0170 W 802.11ax HE160: 12.14 dBm / 0.0164 W <UNII-7> 802.11ax HE20: 11.77 dBm / 0.0150 W 802.11ax HE40: 11.75 dBm / 0.0150 W 802.11ax HE80: 11.93 dBm / 0.0156 W 802.11ax HE160: 11.35 dBm / 0.0136 W</p>



Product Specification is subject to this standard	
99% Occupied Bandwidth <SDM Mode>	<Indoor Client> MIMO <Ant. 9> 802.11ax HE20: 19.08 MHz 802.11ax HE40: 38.06 MHz 802.11ax HE80: 77.32 MHz 802.11ax HE160: 156.08 MHz MIMO <Ant. 8> 802.11ax HE20: 19.18 MHz 802.11ax HE40: 38.06 MHz 802.11ax HE80: 77.32 MHz 802.11ax HE160: 156.32 MHz
	<Standard Client> MIMO <Ant. 9> 802.11ax HE20: 18.98 MHz 802.11ax HE40: 38.06 MHz 802.11ax HE80: 77.32 MHz 802.11ax HE160: 156.80 MHz MIMO <Ant. 8> 802.11ax HE20: 18.98 MHz 802.11ax HE40: 38.06 MHz 802.11ax HE80: 77.20 MHz 802.11ax HE160: 156.56 MHz
99% Occupied Bandwidth <CDD Mode>	<Indoor Client> MIMO <Ant. 9> 802.11a: 16.43 MHz MIMO <Ant. 8> 802.11a: 16.43 MHz
	<Standard Client> MIMO <Ant. 9> 802.11a: 16.43 MHz MIMO <Ant. 8> 802.11a: 16.43 MHz
Antenna Type	<UNII-5> <Ant. 9> : PIFA Antenna <Ant. 8> : PIFA Antenna <UNII-6> <Ant. 9> : PIFA Antenna <Ant. 8> : PIFA Antenna <UNII-7> <Ant. 9> : PIFA Antenna <Ant. 8> : PIFA Antenna <UNII-8> <Ant. 9> : PIFA Antenna <Ant. 8> : PIFA Antenna



Product Specification is subject to this standard					
Antenna Gain	Band	Chain Port 0 Ant 9 (dBi)	Chain Port 1 Ant 8 (dBi)	DG for Power (dBi)	DG for PSD (dBi)
	SDM mode				
	U-NII-5	3.90	3.20	3.56	3.56
	U-NII-6	3.90	3.20	3.56	3.56
	U-NII-7	3.90	3.20	3.56	3.56
	U-NII-8	3.90	4.00	3.95	3.95
	CDD mode				
	U-NII-5	3.90	3.20	3.90	6.57
	U-NII-6	3.90	3.20	3.90	6.57
	U-NII-7	3.90	3.20	3.90	6.57
	U-NII-8	3.90	4.00	4.00	6.96
	TxBF mode				
	U-NII-5	3.90	3.20	6.57	6.57
	U-NII-6	3.90	3.20	6.57	6.57
	U-NII-7	3.90	3.20	6.57	6.57
	U-NII-8	3.90	4.00	6.96	6.96
Type of Modulation	802.11a/n: OFDM (BPSK/QPSK/16QAM/64QAM) 802.11ac: OFDM (BPSK/QPSK/16QAM/64QAM/256QAM) 802.11ax: OFDMA (BPSK/QPSK/16QAM/64QAM/256QAM/1024QAM)				
Antenna Function Description		Ant. 9	Ant. 8		
	802.11 n/ac/ax SDM	V	V		
	802.11 a/n/ac/ax CDD	V	V		
	802.11 ax TXBF	V	V		

Remark:

1. MIMO Ant. 9+8 Directional Gain is a calculated result from MIMO Ant. 9 and MIMO Ant. 8. The formula used in calculation is documented in section 3.8.
2. Power of MIMO Ant. 9 + Ant. 8 is a calculated result from sum of the power MIMO Ant. 9 and MIMO Ant. 8.

Antenna Information				
Antenna 9	Brand Name	Auden Corp	Model Name	025.90243.0001
Antenna 8	Brand Name	Auden Corp	Model Name	025.90243.0001

Remark: The EUT's information above is declared by manufacturer. Please refer to Comments and Explanations in report summary.



	Indoor		Outdoor	
	MIMO(SDM mode and CDD mode)	TXBF	MIMO(SDM mode and CDD mode)	TXBF
26 dB and 99% BW	page 37~40 of 255 (SDM mode) page 45~46 of 255 (CDD mode)	SDM mode cover TxBF	page 41~44 of 255 (SDM mode) page 47~48 of 255 (CDD mode)	SDM mode cover TxBF
In-Band Emissions Mask	page 123~158 of 255 (SDM mode) page 199~202 of 255 (CDD mode)	page 207~214 of 255	page 159~198 of 255 (SDM mode) page 203~206 of 255 (CDD mode)	page 215~218 of 255
Radiated Spurious	page B30~B38 of B82 (SDM mode) page B62~B79 of B82 (SDM mode) page C44~C52 of C109 (SDM mode) page C75~C108 of C109 (SDM mode) page B27~B29 of B82(CDD mode) page B57~B61 of B82(CDD mode) page C41~C43 of C109(CDD mode) page C71~C74 of C109(CDD mode)	SDM mode EIRP cover TxBF	page B6~B26 of B82 (SDM mode) page B43~B56 of B82 (SDM mode) page C5~C24 of C109 (SDM mode) page C29~C40 of C109 (SDM mode) page C57~C70 of C109 (SDM mode) page B1~B5 of B82(CDD mode) page B39~B42 of B82(CDD mode) page C1~C4 of C109(CDD mode) page C25~C28 of C109(CDD mode) page C53~C56 of C109(CDD mode)	SDM mode EIRP cover TxBF
Output Power EIRP	page 51~58 of 255 (SDM mode) page 63~74 of 255 (CDD mode)	page 79~81 of 255	page 59~62 of 255 (SDM mode) page 75~78 of 255 (CDD mode)	page 82 of 255
PSD EIRP	page 86~96 of 255 (SDM mode) page 103~105 of 255 (CDD mode)	page 108~114 of 255	page 97~102 of 255 (SDM mode) page 106~107 of 255 (CDD mode)	page 115~120 of 255
Contention Based Protocol	page 222~241 of 255			

1.3 Modification of EUT

No modifications made to the EUT during the testing.



1.4 Testing Location

Test Site	Sporton International Inc. EMC & Wireless Communications Laboratory
Test Site Location	No.52, Huaya 1st Rd., Guishan Dist., Taoyuan City 333, Taiwan (R.O.C.) TEL: +886-3-327-3456 FAX: +886-3-328-4978
Test Site No.	Sporton Site No. CO05-HY, DF02-HY

Note: The test site complies with ANSI C63.4 2014 requirement.

Test Site	Sporton International Inc. Wensan Laboratory
Test Site Location	No.58, Aly. 75, Ln. 564, Wenhua 3rd, Rd., Guishan Dist., Taoyuan City 333010, Taiwan (R.O.C.) TEL: +886-3-327-0868 FAX: +886-3-327-0855
Test Site No.	Sporton Site No. TH05-HY, 03CH15-HY (TAF Code: 3786)
Remark	The conducted and unwanted emissions test items subcontracted to Sporton International Inc. Wensan Laboratory

Note: The test site complies with ANSI C63.4 2014 requirement.

FCC designation No.: TW1190 and TW3786

1.5 Applicable Standards

According to the specifications declared by the manufacturer, the EUT must comply with the requirements of the following standards:

- ♦ FCC Part 15 Subpart E
- ♦ FCC KDB 789033 D02 General UNII Test Procedures New Rules v02r01.
- ♦ FCC KDB 987594 D02 U-NII 6 GHz EMC Measurement v01
- ♦ FCC KDB 414788 D01 Radiated Test Site v01r01.
- ♦ FCC KDB 662911 D01 Multiple Transmitter Output v02r01.
- ♦ ANSI C63.10-2013

Remark:

1. All the test items were validated and recorded in accordance with the standards without any modification during the testing.
2. The TAF code is not including all the FCC KDB listed without accreditation.
3. This EUT has also been tested and complied with the requirements of FCC Part 15, Subpart B, recorded in a separate test report.



2 Test Configuration of Equipment Under Test

- a. The EUT has been associated with peripherals and configuration operated in a manner tended to maximize its emission characteristics in a typical application. Frequency range investigated: conduction emission (150 kHz to 30 MHz), radiation emission (9 kHz to the 10th harmonic of the highest fundamental frequency or to 40 GHz, whichever is lower). For radiated measurement, , the measured emission level of the EUT was maximized by rotating the EUT on a turntable, adjusting the orientation of the EUT and EUT antenna in three orthogonal axis (X: flat, Y: portrait, Z: landscape), and adjusting the measurement antenna orientation, following C63.10 exploratory test procedures and find Z plane as worst plane.
- b. AC power line Conducted Emission was tested under maximum output power.

2.1 Carrier Frequency and Channel

BW 20M	Channel	1	5	9	13	17	21	25	29
	Freq. (MHz)	5955	5975	5995	6015	6035	6055	6075	6095
BW 40M	Channel	3		11		19		27	
	Freq. (MHz)	5965		6005		6045		6085	
BW 80M	Channel	7				23			
	Freq. (MHz)	5985				6065			
BW 160M	Channel	15							
	Freq. (MHz)	6025							

BW 20M	Channel	33	37	41	45	49	53	57	61
	Freq. (MHz)	6115	6135	6155	6175	6195	6215	6235	6255
BW 40M	Channel	35		43		51		59	
	Freq. (MHz)	6125		6165		6205		6245	
BW 80M	Channel	39				55			
	Freq. (MHz)	6145				6225			
BW 160M	Channel	47							
	Freq. (MHz)	6185							



BW 20M	Channel	65	69	73	77	81	85	89	93
	Freq. (MHz)	6275	6295	6315	6335	6355	6375	6395	6415
BW 40M	Channel	67		75		83		91	
	Freq. (MHz)	6285		6325		6365		6405	
BW 80M	Channel	71				87			
	Freq. (MHz)	6305				6385			
BW 160M	Channel	79							
	Freq. (MHz)	6345							

BW 20M	Channel	97	101	105	109	113	117	121	125
	Freq. (MHz)	6435	6455	6475	6495	6515	6535	6555	6575
BW 40M	Channel	99		107		115		123	
	Freq. (MHz)	6445		6485		6525		6565	
BW 80M	Channel	103				119			
	Freq. (MHz)	6465				6545			
BW 160M	Channel	111							
	Freq. (MHz)	6505							

BW 20M	Channel	129	133	137	141	145	149	153	157
	Freq. (MHz)	6595	6615	6635	6655	6675	6695	6715	6735
BW 40M	Channel	131		139		147		155	
	Freq. (MHz)	6605		6645		6685		6725	
BW 80M	Channel	135				151			
	Freq. (MHz)	6625				6705			
BW 160M	Channel	143							
	Freq. (MHz)	6665							

BW 20M	Channel	161	165	169	173	177	181	185	189
	Freq. (MHz)	6755	6775	6795	6815	6835	6855	6875	6895
BW 40M	Channel	163		171		179		187	
	Freq. (MHz)	6765		6805		6845		6885	
BW 80M	Channel	167				183			
	Freq. (MHz)	6785				6865			
BW 160M	Channel	175							
	Freq. (MHz)	6825							



BW 20M	Channel	193	197	201	205	209	213	217	221
	Freq. (MHz)	6915	6935	6955	6975	6995	7015	7035	7055
BW 40M	Channel	195		203		211		219	
	Freq. (MHz)	6925		6965		7005		7045	
BW 80M	Channel	199				215			
	Freq. (MHz)	6945				7025			
BW 160M	Channel	207							
	Freq. (MHz)	6985							
BW 20M	Channel	225				229			
	Freq. (MHz)	7075				7095			
BW 40M	Channel	227							
	Freq. (MHz)	7085							
BW 20M	Channel	233							
	Freq. (MHz)	7115							



2.2 Test Mode

The conducted power and PSD for indoor client mode is smaller than standard client mode, so all other conducted and radiated test is covered by standard client mode.

The power for 802.11n and 802.11ac mode is smaller than 802.11ax mode, so all other conducted and radiated test is covered by 802.11ax mode.

The PSD of partial RU is reduced to be smaller than full RU according to TCB workshop interim guidance Oct., 2018.

The 242-tone RU is covered by 20MHz channel, 484-tone RU is covered by 40MHz channel and 996-tone RU is covered by 80MHz channel.

The 802.11ax mode is investigated among different tones, full resource units (RU), partial resource units. The partial RU has no higher power than full RU's, thus the full RU is chosen as main test configuration.

The SISO mode conducted power is covered by MIMO mode per chain, so only the MIMO mode is tested.

The SDM mode is chosen as main configuration for all MIMO test cases due to SDM EIRP is higher than CDD and TXBF modes.

The radiated spurious emission is tested under SDM because the conducted power for SDM mode and CDD mode is 3dB higher than TXBF mode and CDD modes. The high power condition dominates the result of unwanted spurious emissions.

The final test modes include the worst data rates for each modulation shown in the table below.



<SDM Mode>
<Indoor Client>

Modulation	Data Rate
802.11n HT20 (Covered by HE20)	MCS0
802.11n HT40 (Covered by HE40)	MCS0
802.11ac VHT20 (Covered by HE20)	MCS0
802.11ac VHT40 (Covered by HE40)	MCS0
802.11ac VHT80 (Covered by HE80)	MCS0
802.11ac VHT160 (Covered by HE160)	MCS0
802.11ax HE20	MCS0
802.11ax HE40	MCS0
802.11ax HE80	MCS0
802.11ax HE160	MCS0

<Standard Client>

Modulation	Data Rate
802.11n HT20 (Covered by HE20)	MCS0
802.11n HT40 (Covered by HE40)	MCS0
802.11ac VHT20 (Covered by HE20)	MCS0
802.11ac VHT40 (Covered by HE40)	MCS0
802.11ac VHT80 (Covered by HE80)	MCS0
802.11ac VHT160 (Covered by HE160)	MCS0
802.11ax HE20	MCS0
802.11ax HE40	MCS0
802.11ax HE80	MCS0
802.11ax HE160	MCS0



<CDD Mode>

<Indoor Client>

Modulation	Data Rate
802.11a	6 Mbps
802.11n HT20 (Covered by HE20)	MCS0
802.11n HT40 (Covered by HE40)	MCS0
802.11ac VHT20 (Covered by HE20)	MCS0
802.11ac VHT40 (Covered by HE40)	MCS0
802.11ac VHT80 (Covered by HE80)	MCS0
802.11ac VHT160 (Covered by HE160)	MCS0
802.11ax HE20	MCS0
802.11ax HE40	MCS0
802.11ax HE80	MCS0
802.11ax HE160	MCS0

<Standard Client>

Modulation	Data Rate
802.11a	6 Mbps
802.11n HT20 (Covered by HE20)	MCS0
802.11n HT40 (Covered by HE40)	MCS0
802.11ac VHT20 (Covered by HE20)	MCS0
802.11ac VHT40 (Covered by HE40)	MCS0
802.11ac VHT80 (Covered by HE80)	MCS0
802.11ac VHT160 (Covered by HE160)	MCS0
802.11ax HE20	MCS0
802.11ax HE40	MCS0
802.11ax HE80	MCS0
802.11ax HE160	MCS0



<TXBF Mode>

<Indoor Client>

Modulation	Data Rate
802.11ax HE20	MCS0
802.11ax HE40	MCS0
802.11ax HE80	MCS0
802.11ax HE160	MCS0

<Standard Client>

Modulation	Data Rate
802.11ax HE20	MCS0
802.11ax HE40	MCS0
802.11ax HE80	MCS0
802.11ax HE160	MCS0

Test Cases	
AC Conducted Emission	Mode 1 : WCDMA Band V Link + WLAN (5GHz) Link + Bluetooth Link + NFC On + USB TYPE A to TYPE C cable (Charging with Adapter) + Battery 1X for Sample 2
Remark: For Radiated Test Cases, the tests were performed with Battery 1X and Sample 2.	



Ch. #		UNII-5 (5925-6425 MHz)	UNII-6 (6425-6525 MHz)	UNII-7 (6525-6875 MHz)	UNII-8 (6875-7125 MHz)
		802.11a	802.11a	802.11a	802.11a
L	Low	001	097	117	189
		002	-	-	-
M	Middle	049	105	149	209
		-	-	-	229
H	High	093	113	181	233
Straddle		-	-	185	-

Ch. #		UNII-5 (5925-6425 MHz)	UNII-6 (6425-6525 MHz)	UNII-7 (6525-6875 MHz)	UNII-8 (6875-7125 MHz)
		802.11ax HE20	802.11ax HE20	802.11ax HE20	802.11ax HE20
L	Low	001	097	117	189
		002	-	-	-
M	Middle	049	105	149	209
H	High	093	113	181	229
					233
Straddle		-	-	185	-

Ch. #		UNII-5 (5925-6425 MHz)	UNII-6 (6425-6525 MHz)	UNII-7 (6525-6875 MHz)	UNII-8 (6875-7125 MHz)
		802.11ax HE40	802.11ax HE40	802.11ax HE40	802.11ax HE40
L	Low	003	099	123	195
M	Middle	051	-	147	211
H	High	091	107	179	227
Straddle		-	115	187	-

Ch. #		UNII-5 (5925-6425 MHz)	UNII-6 (6425-6525 MHz)	UNII-7 (6525-6875 MHz)	UNII-8 (6875-7125 MHz)
		802.11ax HE80	802.11ax HE80	802.11ax HE80	802.11ax HE80
L	Low	007	103	135	199
M	Middle	055		151	-
H	High	087		167	215
Straddle		-	119	183	-



Ch. #		UNII-5 (5925-6425 MHz)	UNII-6 (6425-6525 MHz)	UNII-7 (6525-6875 MHz)	UNII-8 (6875-7125 MHz)
		802.11ax HE160	802.11ax HE160	802.11ax HE160	802.11ax HE160
L	Low	015	-	143	207
M	Middle	047			
H	High	079			
Straddle		-	111	175	-

Remark: Based on ANSI C63.10 clause 5.6.2.2, b) Spurious emissions, measure the mode with the highest output power and the mode with highest output power spectral density for each modulation family.

<SDM Mode>

MIMO <Ant. 9+8>

<Indoor Client>

802.11ax HE20 RF Output Power (dBm)															
Power vs. Channel				Power vs Data Rate											
Channel	Frequency (MHz)	RU Config.	MCS Index	Channel	MCS Index										
			MCS0		MCS1	MCS2	MCS3	MCS4	MCS5	MCS6	MCS7	MCS8	MCS9	MCS10	MCS11
Duty Cycle (%)															
CH 001	5955	Full	7.81	CH 001	7.71	7.71	7.61	7.61	7.71	7.71	7.71	7.61	7.61	7.71	7.71
CH 001	5955	26/0	-2.13												
CH 001	5955	52/37	0.71												
CH 001	5955	106/53	3.87												
CH 049	6195	Full	7.77												
CH 049	6195	26/4	-1.04												
CH 049	6195	52/39	0.81												
CH 049	6195	106/53	4.41												
CH 093	6415	Full	7.61												
CH 093	6415	26/8	-0.80												
CH 093	6415	52/40	0.57												
CH 093	6415	106/54	3.66												



802.11ax HE20 RF Output Power (dBm)															
Power vs. Channel				Power vs Data Rate											
Channel	Frequency (MHz)	RU Config.	MCS Index	Channel	MCS Index										
			MCS0		MCS1	MCS2	MCS3	MCS4	MCS5	MCS6	MCS7	MCS8	MCS9	MCS10	MCS11
Duty Cycle (%)															
CH 097	6435	Full	7.61	CH 097	7.51	7.51	7.41	7.41	7.51	7.51	7.51	7.41	7.41	7.51	7.51
CH 097	6435	26/0	-1.84												
CH 097	6435	52/37	0.97												
CH 097	6435	106/53	4.02												
CH 105	6475	Full	7.16												
CH 105	6475	26/4	-1.69												
CH 105	6475	52/39	0.51												
CH 105	6475	106/54	3.28												
CH 113	6515	Full	7.51												
CH 113	6515	26/8	-2.62												
CH 113	6515	52/40	0.71												
CH 113	6515	106/54	3.79												
CH 117	6535	Full	7.06	CH 181	7.52	7.52	7.42	7.42	7.52	7.52	7.52	7.42	7.42	7.52	7.52
CH 117	6535	26/0	-2.56												
CH 117	6535	52/37	0.40												
CH 117	6535	106/53	3.42												
CH 149	6695	Full	7.41												
CH 149	6695	26/4	-1.49												
CH 149	6695	52/38	0.61												
CH 149	6695	106/53	4.11												
CH 181	6855	Full	7.62												
CH 181	6855	26/8	-1.99												
CH 181	6855	52/40	0.96												
CH 181	6855	106/54	3.57												
CH 185	6875	Full	7.36												
CH 185	6875	26/8	-2.44												
CH 185	6875	52/40	0.46												
CH 185	6875	106/54	3.62												



802.11ax HE20 RF Output Power (dBm)																
Power vs. Channel				Power vs Data Rate												
Channel	Frequency (MHz)	RU Config.	MCS Index	Channel	MCS Index											
			MCS0		MCS1	MCS2	MCS3	MCS4	MCS5	MCS6	MCS7	MCS8	MCS9	MCS10	MCS11	
Duty Cycle (%)																
CH 189	6895	Full	7.16	CH 229												
CH 189	6895	26/0	-2.43													
CH 189	6895	52/37	0.01													
CH 189	6895	106/53	3.06													
CH 209	6995	Full	7.31													
CH 209	6995	26/4	-1.78													
CH 209	6995	52/38	0.21													
CH 209	6995	106/53	3.11													
CH 229	7095	Full	8.37			8.27	8.27	8.17	8.17	8.27	8.27	8.27	8.17	8.17	8.27	8.27
CH 229	7095	26/8	-2.59													
CH 229	7095	52/40	0.51													
CH 229	7095	106/54	3.66													
CH 233	7115	Full	-2.38													
CH 233	7115	26/8	-11.78													
CH 233	7115	52/40	-9.34													
CH 233	7115	106/54	-6.03													

Note: The above Frequency and Channel in "*" were straddle Channel.



802.11ax HE40 RF Output Power (dBm)															
Power vs. Channel				Power vs Data Rate											
Channel	Frequency (MHz)	RU Config.	MCS Index	Channel	MCS Index										
			MCS0		MCS1	MCS2	MCS3	MCS4	MCS5	MCS6	MCS7	MCS8	MCS9	MCS10	MCS11
Duty Cycle (%)															
CH 003	5965	Full	10.47	CH 003	10.37	10.37	10.37	10.07	10.07	10.07	10.07	10.07	10.07	10.17	10.17
CH 003	5965	242/61	5.98												
CH 051	6205	Full	10.42												
CH 051	6205	242/61	7.56												
CH 091	6405	Full	10.36												
CH 091	6405	242/62	7.43												
CH 099	6445	Full	10.26	CH 107	10.36	10.36	10.36	10.06	10.06	10.06	10.06	10.06	10.06	10.16	10.16
CH 099	6445	242/61	7.64												
CH 107	6485	Full	10.46												
CH 107	6485	242/62	7.72												
CH 115*	6525	Full	10.41												
CH 115*	6525	242/62	7.54												
CH 123	6565	Full	10.26	CH 179	10.36	10.36	10.36	10.06	10.06	10.06	10.06	10.06	10.06	10.16	10.16
CH 123	6565	242/61	7.30												
CH 147	6685	Full	10.27												
CH 147	6685	242/61	7.38												
CH 179	6845	Full	10.46												
CH 179	6845	242/62	7.22												
CH 187*	6885	Full	10.16	CH 227	10.62	10.62	10.62	10.32	10.32	10.32	10.32	10.32	10.32	10.42	10.42
CH 187*	6885	242/62	6.88												
CH 195	6925	Full	10.26												
CH 195	6925	242/61	6.95												
CH 211	7005	Full	10.36												
CH 211	7005	242/62	6.87												
CH 227	7085	Full	10.72	CH 227	10.62	10.62	10.62	10.32	10.32	10.32	10.32	10.32	10.32	10.42	10.42
CH 227	7085	242/62	7.03												

Note: The above Frequency and Channel in "*" were straddle Channel.



802.11ax HE80 RF Output Power (dBm)															
Power vs. Channel				Power vs Data Rate											
Channel	Frequency (MHz)	RU Config.	MCS Index	Channel	MCS Index										
			MCS0		MCS1	MCS2	MCS3	MCS4	MCS5	MCS6	MCS7	MCS8	MCS9	MCS10	MCS11
Duty Cycle (%)															
CH 007	5985	Full	13.37												
CH 007	5985	484/65	10.36												
CH 055	6225	Full	13.51	CH 055	13.41	13.41	13.41	13.41	13.41	13.41	13.41	13.41	13.41	13.41	13.41
CH 055	6225	484/65	10.46												
CH 087	6385	Full	13.31												
CH 087	6385	484/66	10.01												
CH 103	6465	Full	13.01	CH119*	13.26	13.26	13.26	13.26	13.26	13.26	13.26	13.26	13.26	13.26	13.26
CH 103	6465	484/65	10.48												
CH119*	6545	Full	13.36												
CH119*	6545	484/66	10.30												
CH 135	6625	Full	13.36	CH 167	13.27	13.27	13.27	13.27	13.27	13.27	13.27	13.27	13.27	13.27	13.27
CH 135	6625	484/65	9.87												
CH 151	6705	Full	13.21												
CH 151	6705	484/65	9.98												
CH 167	6785	Full	13.37												
CH 167	6785	484/66	9.81												
CH 183*	6865	Full	13.31												
CH 183*	6865	484/66	10.03												
CH 199	6945	Full	13.26	CH 215	13.57	13.57	13.57	13.57	13.57	13.57	13.57	13.57	13.57	13.57	13.57
CH 199	6945	484/65	9.60												
CH 215	7025	Full	13.67												
CH 215	7025	484/66	10.07												

Note: The above Frequency and Channel in "*" were straddle Channel.



802.11ax HE160 RF Output Power (dBm)															
Power vs. Channel				Power vs Data Rate											
Channel	Frequency (MHz)	RU Config.	MCS Index	Channel	MCS Index										
			MCS0		MCS1	MCS2	MCS3	MCS4	MCS5	MCS6	MCS7	MCS8	MCS9	MCS10	MCS11
Duty Cycle (%)															
CH 015	6025	Full	15.41	CH 015	15.31	15.31	15.31	15.11	15.11	15.11	15.01	15.01	15.01	15.11	15.11
CH 015	6025	996/67	12.66												
CH 047	6185	Full	15.17												
CH 047	6185	996/67	11.41												
CH 079	6345	Full	15.11												
CH 079	6345	996/S67	12.31												
CH 111*	6505	Full	14.87	CH 111*	14.77	14.77	14.77	14.57	14.57	14.57	14.47	14.47	14.47	14.57	14.57
CH 111*	6505	996/67	12.34												
CH 111*	6505	996/S67	11.70												
CH 143	6665	Full	14.76	CH 143	14.66	14.66	14.66	14.46	14.46	14.46	14.36	14.36	14.36	14.46	14.46
CH 143	6665	996/67	11.77												
CH 175	6825	Full	14.57												
CH 175	6825	996/S67	11.71												
CH 207	6985	Full	14.28	CH 207	14.18	14.18	14.18	13.98	13.98	13.98	13.88	13.88	13.88	13.98	13.98
CH 207	6985	996/67	11.63												
CH 207	6985	996/S67	11.17												

Note: The above Frequency and Channel in "*" were straddle Channel.



<Standard Client>

802.11ax HE20 RF Output Power (dBm)															
Power vs. Channel				Power vs Data Rate											
Channel	Frequency (MHz)	RU Config.	MCS Index	Channel	MCS Index										
			MCS0		MCS1	MCS2	MCS3	MCS4	MCS5	MCS6	MCS7	MCS8	MCS9	MCS10	MCS11
Duty Cycle (%)															
CH 001	5955	Full	15.21												
CH 001	5955	26/0	5.37												
CH 001	5955	52/37	8.36												
CH 001	5955	106/53	11.41												
CH 049	6195	Full	15.00												
CH 049	6195	26/4	6.27												
CH 049	6195	52/39	8.03	CH 093	15.26	15.26	15.16	15.16	15.26	15.26	15.26	15.16	15.16	15.26	15.26
CH 049	6195	106/53	11.33												
CH 093	6415	Full	15.36												
CH 093	6415	26/8	5.64												
CH 093	6415	52/40	8.48												
CH 093	6415	106/54	11.68												
CH 117	6535	Full	14.54												
CH 117	6535	26/0	5.23												
CH 117	6535	52/37	8.35												
CH 117	6535	106/53	10.74												
CH 149	6695	Full	14.76												
CH 149	6695	26/4	5.77												
CH 149	6695	52/38	7.71	CH 181	14.71	14.71	14.61	14.61	14.71	14.71	14.71	14.61	14.61	14.71	14.71
CH 149	6695	106/53	11.01												
CH 181	6855	Full	14.81												
CH 181	6855	26/8	4.88												
CH 181	6855	52/40	7.51												
CH 181	6855	106/54	10.96												

Note: The above Frequency and Channel in "*" were straddle Channel.



802.11ax HE40 RF Output Power (dBm)															
Power vs. Channel				Power vs Data Rate											
Channel	Frequency (MHz)	RU Config.	MCS Index	Channel	MCS Index										
			MCS0		MCS1	MCS2	MCS3	MCS4	MCS5	MCS6	MCS7	MCS8	MCS9	MCS10	MCS11
Duty Cycle (%)															
CH 003	5965	Full	15.41	CH 003	15.31	15.31	15.31	15.01	15.01	15.01	15.01	15.01	15.01	15.11	15.11
CH 003	5965	242/61	12.26												
CH 051	6205	Full	14.94												
CH 051	6205	242/61	11.83												
CH 091	6405	Full	15.31												
CH 091	6405	242/62	12.12												
CH 123	6565	Full	14.67	CH 179	14.86	14.86	14.86	14.56	14.56	14.56	14.56	14.56	14.56	14.66	14.66
CH 123	6565	242/61	11.73												
CH 147	6685	Full	14.76												
CH 147	6685	242/61	11.66												
CH 179	6845	Full	15.01												
CH 179	6845	242/62	11.11												

Note: The above Frequency and Channel in "*" were straddle Channel.



802.11ax HE80 RF Output Power (dBm)															
Power vs. Channel				Power vs Data Rate											
Channel	Frequency (MHz)	RU Config.	MCS Index	Channel	MCS Index										
			MCS0		MCS1	MCS2	MCS3	MCS4	MCS5	MCS6	MCS7	MCS8	MCS9	MCS10	MCS11
Duty Cycle (%)															
CH 007	5985	Full	15.17	CH 087	15.36	15.36	15.36	15.36	15.36	15.36	15.36	15.36	15.36	15.36	15.36
CH 007	5985	484/65	12.11												
CH 055	6225	Full	15.27												
CH 055	6225	484/65	12.26												
CH 087	6385	Full	15.46												
CH 087	6385	484/66	12.36												
CH 135	6625	Full	14.67	CH 167	14.86	14.86	14.86	14.86	14.86	14.86	14.86	14.86	14.86	14.86	14.86
CH 135	6625	484/65	11.61												
CH 151	6705	Full	14.61												
CH 151	6705	484/65	11.61												
CH 167	6785	Full	14.96												
CH 167	6785	484/66	11.96												

Note: The above Frequency and Channel in "*" were straddle Channel.



802.11ax HE160 RF Output Power (dBm)															
Power vs. Channel				Power vs Data Rate											
Channel	Frequency (MHz)	RU Config.	MCS Index	Channel	MCS Index										
			MCS0		MCS1	MCS2	MCS3	MCS4	MCS5	MCS6	MCS7	MCS8	MCS9	MCS10	MCS11
Duty Cycle (%)															
CH 015	6025	Full	15.17	CH 015	15.07	15.07	15.07	14.87	14.87	14.87	14.77	14.77	14.77	14.87	14.87
CH 015	6025	996/67	12.41												
CH 047	6185	Full	14.98												
CH 047	6185	996/67	12.36												
CH 079	6345	Full	15.16												
CH 079	6345	996/S67	12.21												
CH 143	6665	Full	14.57	CH 175	14.81	14.81	14.81	14.61	14.61	14.61	14.51	14.51	14.51	14.61	14.61
CH 143	6665	996/67	11.71												
CH 175	6825	Full	14.91												
CH 175	6825	996/S67	11.66												

Note: The above Frequency and Channel in "*" were straddle Channel.



<CDD Mode>

MIMO <Ant. 9+8>

<Indoor Client>

802.11a RF Output Power (dBm)										
Power vs. Channel			Power vs Data Rate							
Channel	Frequency (MHz)	Data Rate (bps)	Channel	Data Rate (bps)						
		6M		9M	12M	18M	24M	36M	48M	54M
Duty Cycle (%)										
CH 001	5955	3.71	CH 049	3.72	3.72	3.72	3.72	3.72	3.72	3.72
CH 049	6195	3.82								
CH 093	6415	3.56								
CH 097	6435	3.77	CH 097	3.67	3.67	3.67	3.67	3.67	3.67	3.67
CH 105	6475	3.41								
CH 113	6515	3.34								
CH 117	6535	3.31	CH 181	3.52	3.52	3.52	3.52	3.52	3.52	3.52
CH 149	6695	3.44								
CH 181	6855	3.62								
CH 185*	6875	3.17	CH 233	3.36	3.36	3.36	3.36	3.36	3.36	3.36
CH 189	6895	3.31								
CH 209	6995	3.21								
CH 233	7115	3.46								

Note: The above Frequency and Channel in "*" were straddle Channel.

<Standard Client>

802.11a RF Output Power (dBm)										
Power vs. Channel			Power vs Data Rate							
Channel	Frequency (MHz)	Data Rate (bps)	Channel	Data Rate (bps)						
		6M		9M	12M	18M	24M	36M	48M	54M
Duty Cycle (%)										
CH 001	5955	15.41	CH 001	15.12	15.12	15.12	15.02	15.02	14.92	14.92
CH 049	6195	15.22								
CH 093	6415	15.13								
CH 117	6535	14.25	CH 149	14.53	14.53	14.53	14.53	14.43	14.43	14.33
CH 149	6695	14.63								
CH 181	6855	14.11								

Note: The above Frequency and Channel in "*" were straddle Channel.

2.3 Connection Diagram of Test System

<AC Conducted Emission Mode>

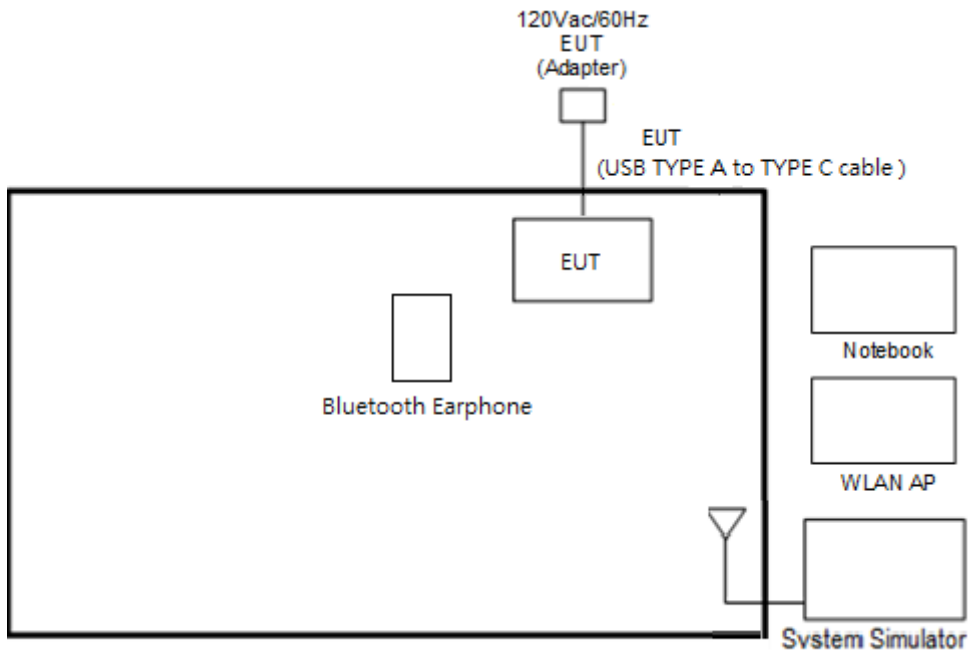

<WLAN Tx Mode>

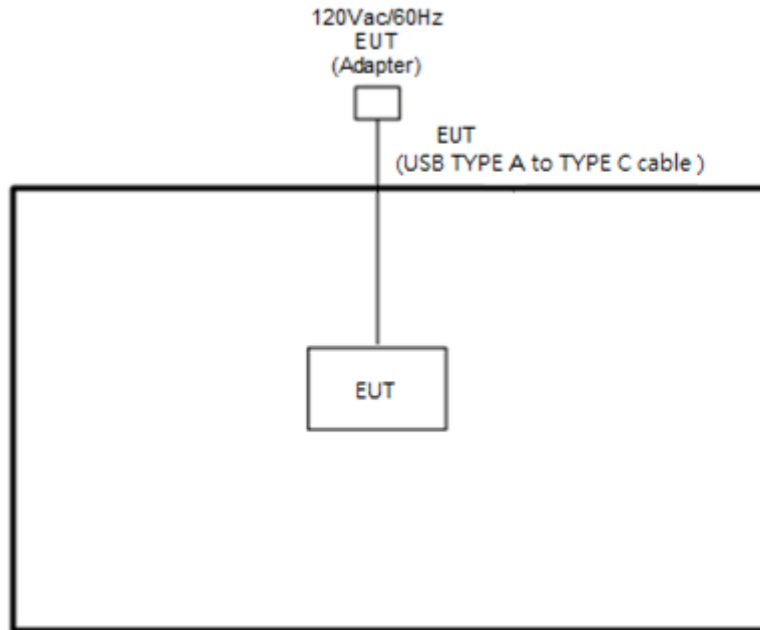

2.4 Support Unit used in test configuration and system

Item	Equipment	Brand Name	Model Name	FCC ID	Data Cable	Power Cord
1.	System Simulator	Anritsu	MT8820C	N/A	N/A	Unshielded, 1.8 m
2.	Bluetooth Earphone	Sony Ericsson	MW600	PY7DDA-2029	N/A	N/A
3.	WLAN AP	ASUS	RT-AC66U	MSQ-RTAC66U	N/A	Unshielded, 1.8 m
4.	Notebook	DELL	Latitude 3400	FCC DoC	N/A	AC I/P: Unshielded, 1.2 m DC O/P: Shielded, 1.8 m
5.	SD Card	SanDisk	MicroSD HC	FCC DoC	N/A	N/A

2.5 EUT Operation Test Setup

The RF test items, utility “QRCT v4.0 version 4.0.00175.0” was installed in Notebook which was programmed in order to make the EUT get into the engineering modes to provide channel selection, power level, data rate and the application type and for continuous transmitting signals.

For TXBF mode, the modulation modes and data rates manipulated by the command lines in the engineering program made the EUT link to another EUT by power under the normal operation. The “Magic iPerf Ver.1.0” software tool was used to enable the EUT to transmit signals continuously.



2.6 Measurement Results Explanation Example

For all conducted test items:

The offset level is set in the spectrum analyzer to compensate the RF cable loss and attenuator factor between EUT conducted output port and spectrum analyzer. With the offset compensation, the spectrum analyzer reading level is exactly the EUT RF output level.

Example :

The spectrum analyzer offset is derived from RF cable loss and attenuator factor.

Offset = RF cable loss + attenuator factor.

Following shows an offset computation example with cable loss 4.2 dB and 10dB attenuator.

$$\begin{aligned} \text{Offset(dB)} &= \text{RF cable loss(dB)} + \text{attenuator factor(dB)}. \\ &= 4.2 + 10 = 14.2 \text{ (dB)} \end{aligned}$$

3 Test Result

3.1 26dB & 99% Occupied Bandwidth Measurement

3.1.1 Limit of 26dB & 99% Occupied Bandwidth

<FCC 14-30 CFR 15.407>

(a)(10) The maximum transmitter channel bandwidth for U-NII devices in the 5.925-7.125 GHz band is 320 megahertz.

3.1.2 Measuring Instruments

Please refer to the measuring equipment list in this test report.

3.1.3 Test Procedures

1. The testing follows FCC KDB 789033 D02 General UNII Test Procedures New Rules v02r01. Section C) Emission bandwidth
2. Set RBW = approximately 1% of the emission bandwidth.
3. Set the VBW > RBW.
4. Detector = Peak.
5. Trace mode = max hold
6. Measure the maximum width of the emission that is 26 dB down from the peak of the emission. Compare this with the RBW setting of the analyzer. Readjust RBW and repeat measurement as needed until the RBW/EBW ratio is approximately 1%.
7. For 99% Bandwidth Measurement, the spectrum analyzer's resolution bandwidth (RBW) is set 1-5% of the emission bandwidth and set the Video bandwidth (VBW) $\geq 3 * RBW$.
8. Measure and record the results in the test report.

3.1.4 Test Setup

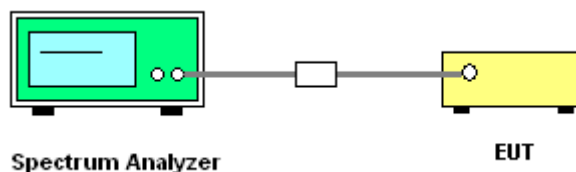



3.1.5 Test Result of 26dB & 99% Occupied Bandwidth

Test Engineer :	Jacob Yu, Hank Hsu and Junyu Jhou	Temperature :	17.7~22.5°C
		Relative Humidity :	45.1~61.9%

<SDM Mode>

<Indoor Client>

Band VI MIMO										
Mod.	Data Rate	NTX	CH.	Freq. (MHz)	RU Config.	99% Bandwidth (MHz)		26 dB Bandwidth (MHz)		Note
						Ant 9	Ant 8	Ant 9	Ant 8	
HE20	MCS0	2	097	6435	Full	18.98	18.93	21.60	21.50	-
HE20	MCS0	2	105	6475	Full	18.98	18.98	21.35	21.55	-
HE20	MCS0	2	113	6515	Full	18.98	18.98	21.50	21.55	-
HE40	MCS0	2	099	6445	Full	37.96	37.96	40.32	40.14	-
HE40	MCS0	2	107	6485	Full	38.06	37.96	40.41	40.50	-
HE80	MCS0	2	103	6465	Full	77.20	77.20	83.04	83.04	-

Band VI straddle channel MIMO										
Mod.	Data Rate	NTX	CH.	Freq. (MHz)	RU Config.	99% Bandwidth (MHz)		26 dB Bandwidth (MHz)		Note
						Ant 9	Ant 8	Ant 9	Ant 8	
HE40	MCS0	2	115	6525	Full	37.96	38.06	40.23	40.59	-
HE80	MCS0	2	119	6545	Full	77.20	77.32	82.88	83.04	-
HE160	MCS0	2	111	6505	Full	156.08	156.32	166.72	165.44	-



Band VIII MIMO										
Mod.	Data Rate	NTX	CH.	Freq. (MHz)	RU Config.	99% Bandwidth (MHz)		26 dB Bandwidth (MHz)		Note
						Ant 9	Ant 8	Ant 9	Ant 8	
HE20	MCS0	2	189	6895	Full	18.98	18.98	21.45	21.50	-
HE20	MCS0	2	209	6995	Full	18.93	18.93	21.35	21.75	-
HE20	MCS0	2	229	7095	Full	18.93	18.98	21.25	21.45	-
HE20	MCS0	2	233	7115	Full	19.08	19.18	21.50	21.65	-
HE40	MCS0	2	195	6925	Full	38.06	37.96	40.50	40.23	-
HE40	MCS0	2	211	7005	Full	37.86	37.96	39.78	40.41	-
HE40	MCS0	2	227	7085	Full	37.96	37.86	40.41	40.50	-
HE80	MCS0	2	199	6945	Full	77.32	77.08	82.56	83.04	-
HE80	MCS0	2	215	7025	Full	77.20	77.32	82.40	82.72	-
HE160	MCS0	2	207	6985	Full	156.08	156.08	165.76	165.12	-

Band VIII straddle channel MIMO										
Mod.	Data Rate	NTX	CH.	Freq. (MHz)	RU Config.	99% Bandwidth (MHz)		26 dB Bandwidth (MHz)		Note
						Ant 9	Ant 8	Ant 9	Ant 8	
HE20	MCS0	2	185	6875	Full	18.98	18.98	21.35	21.30	-
HE40	MCS0	2	187	6885	Full	38.06	37.96	40.32	40.23	-
HE80	MCS0	2	183	6865	Full	77.32	77.20	83.04	83.04	-



<802.11ax HE20>

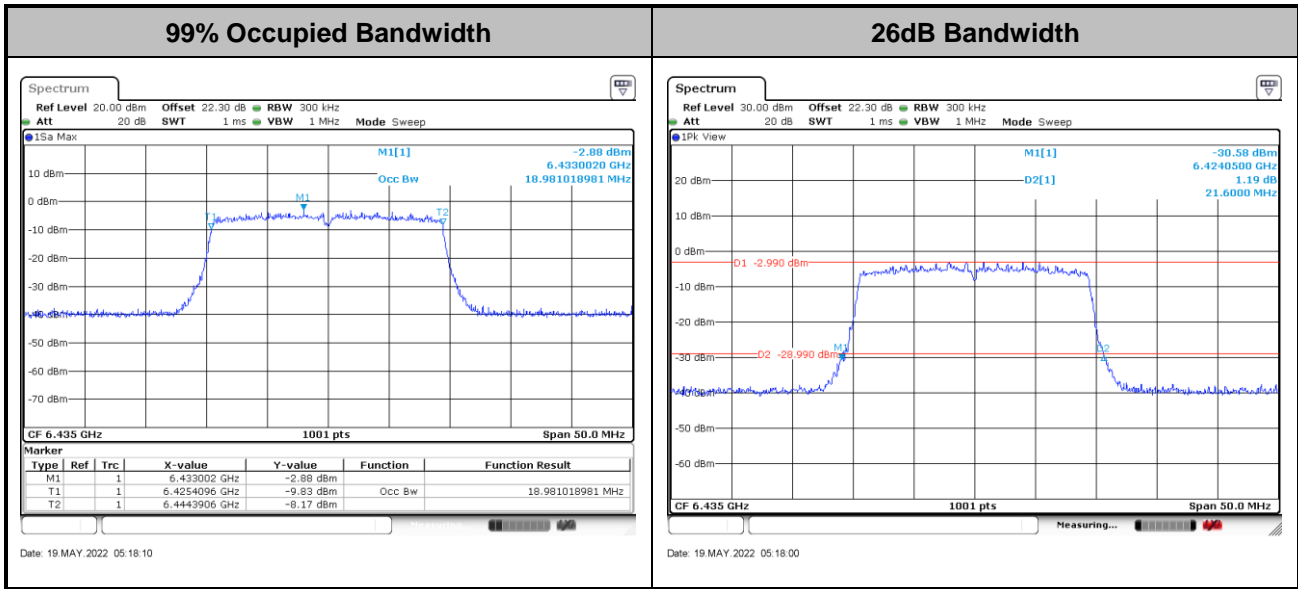

Note: The occupied channel bandwidth is maintained within the band of operation for all of the modulations.

<802.11ax HE40>

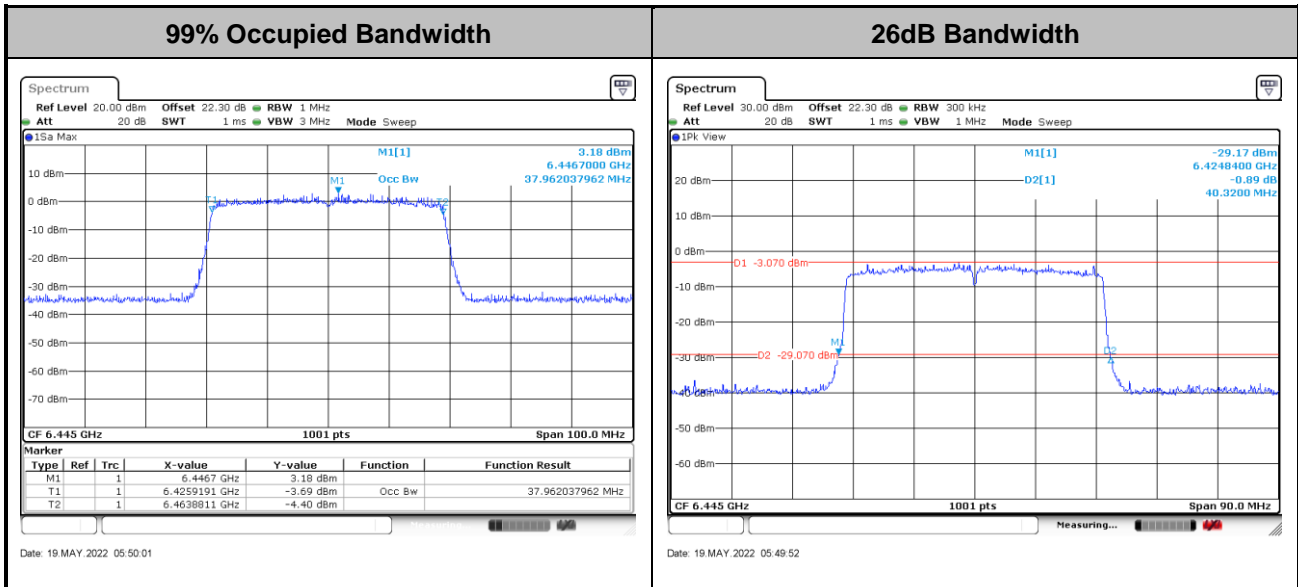

Note: The occupied channel bandwidth is maintained within the band of operation for all of the modulations.



<802.11ax HE80>

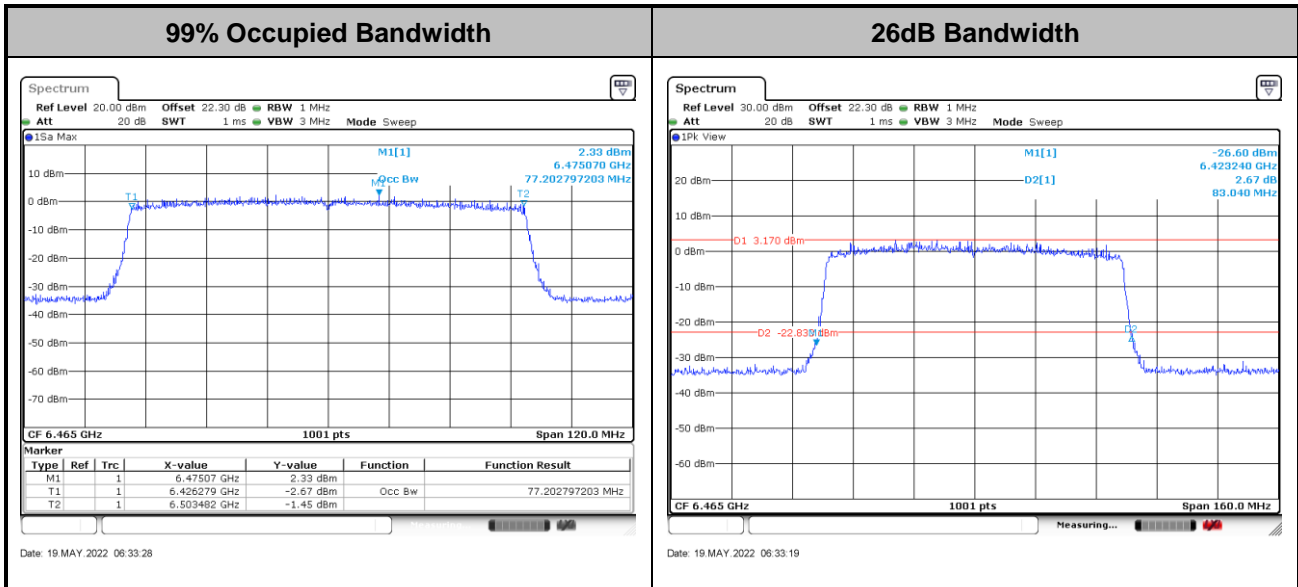

Note: The occupied channel bandwidth is maintained within the band of operation for all of the modulations.

<802.11ax HE160>

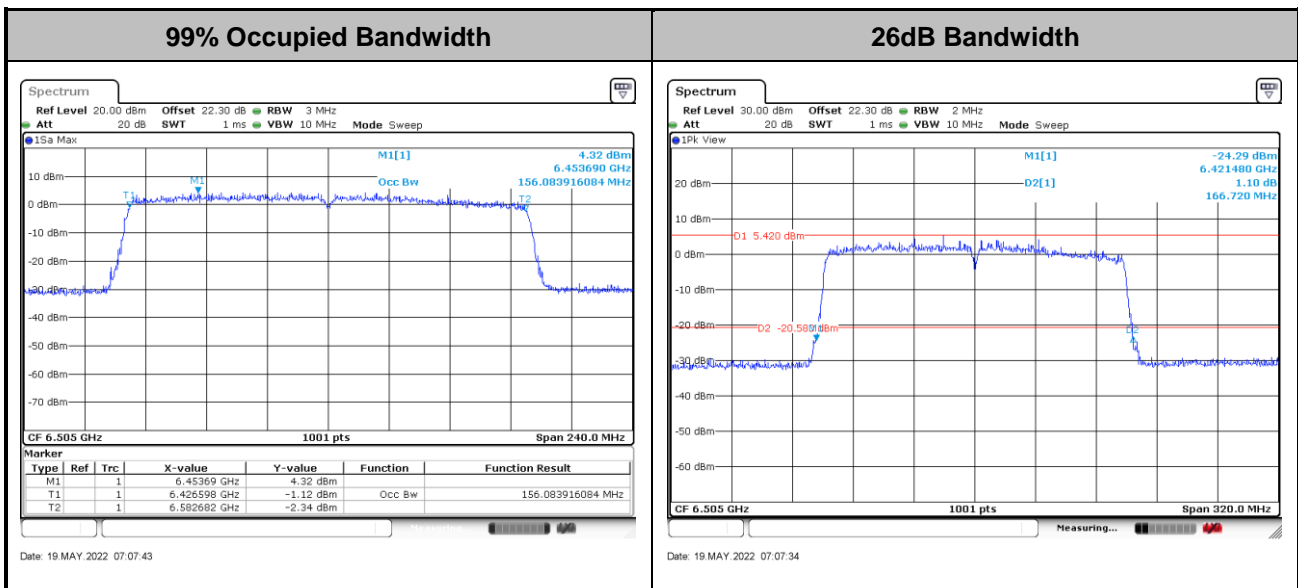

Note: The occupied channel bandwidth is maintained within the band of operation for all of the modulations.



<Standard Client>

Band V MIMO										
Mod.	Data Rate	NTX	CH.	Freq. (MHz)	RU Config.	99% Bandwidth (MHz)		26 dB Bandwidth (MHz)		Note
						Ant 9	Ant 8	Ant 9	Ant 8	
HE20	MCS0	2	001	5955	Full	18.98	18.93	21.50	21.30	-
HE20	MCS0	2	049	6195	Full	18.93	18.98	21.45	21.20	-
HE20	MCS0	2	093	6415	Full	18.93	18.98	21.40	22.05	-
HE40	MCS0	2	003	5965	Full	38.06	37.96	40.59	40.23	-
HE40	MCS0	2	051	6205	Full	37.96	37.96	40.14	40.05	-
HE40	MCS0	2	091	6405	Full	37.96	38.06	40.68	40.05	-
HE80	MCS0	2	007	5985	Full	77.20	77.20	83.36	83.52	-
HE80	MCS0	2	055	6225	Full	77.32	77.20	82.40	82.72	-
HE80	MCS0	2	087	6385	Full	77.20	77.20	83.36	82.24	-
HE160	MCS0	2	015	6025	Full	156.80	156.56	166.08	166.40	-
HE160	MCS0	2	047	6185	Full	156.32	156.32	166.40	167.04	-
HE160	MCS0	2	079	6345	Full	156.08	156.56	166.40	166.72	-



Band VII MIMO										
Mod.	Data Rate	NTX	CH.	Freq. (MHz)	RU Config.	99% Bandwidth (MHz)		26 dB Bandwidth (MHz)		Note
						Ant 9	Ant 8	Ant 9	Ant 8	
HE20	MCS0	2	117	6535	Full	18.93	18.98	21.30	21.95	-
HE20	MCS0	2	149	6695	Full	18.93	18.98	21.35	21.50	-
HE20	MCS0	2	181	6855	Full	18.93	18.98	21.50	21.50	-
HE40	MCS0	2	123	6565	Full	37.96	37.96	40.41	40.59	-
HE40	MCS0	2	147	6685	Full	37.96	38.06	40.59	40.50	-
HE40	MCS0	2	179	6845	Full	37.96	38.06	40.77	40.23	-
HE80	MCS0	2	135	6625	Full	77.32	77.20	83.20	82.88	-
HE80	MCS0	2	151	6705	Full	77.20	77.20	83.04	83.52	-
HE80	MCS0	2	167	6785	Full	77.32	77.20	83.20	83.04	-
HE160	MCS0	2	143	6665	Full	156.56	156.32	166.40	167.04	-
HE160	MCS0	2	175	6825	Full	156.80	156.32	168.00	167.36	-



<802.11ax HE20>

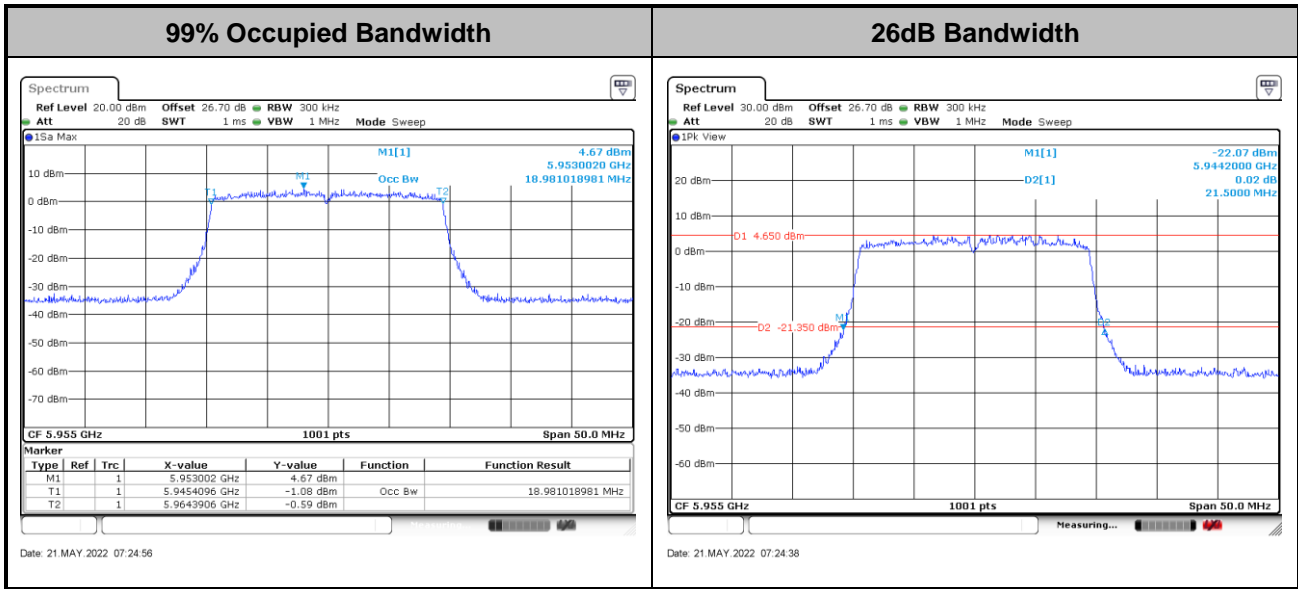

Note: The occupied channel bandwidth is maintained within the band of operation for all of the modulations.

<802.11ax HE40>

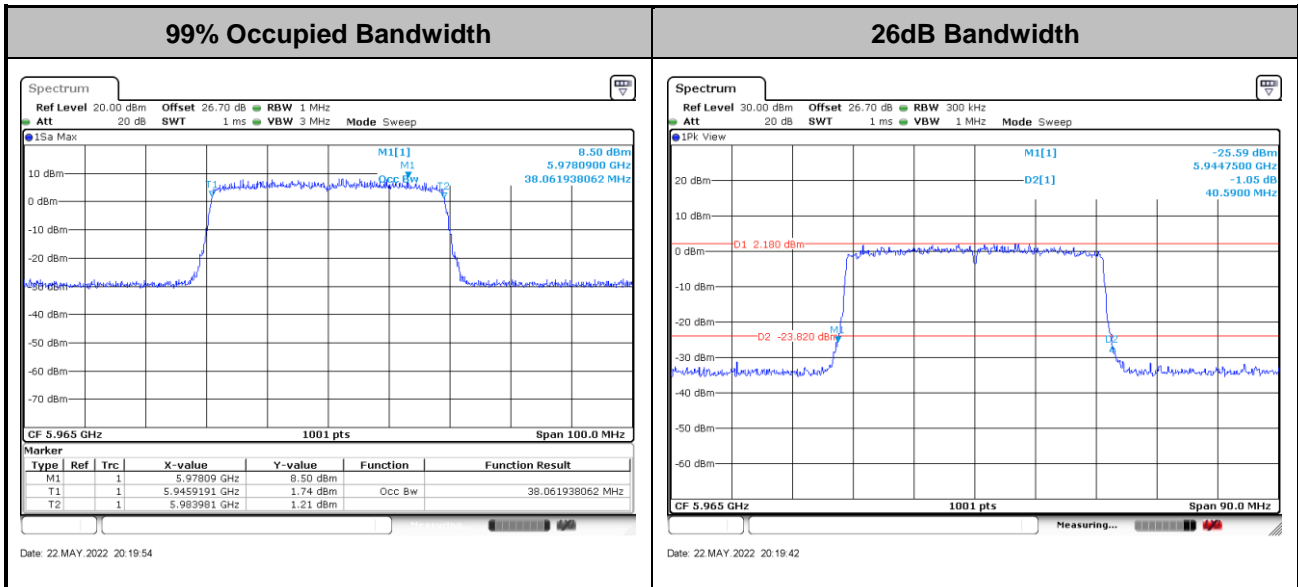

Note: The occupied channel bandwidth is maintained within the band of operation for all of the modulations.



<802.11ax HE80>

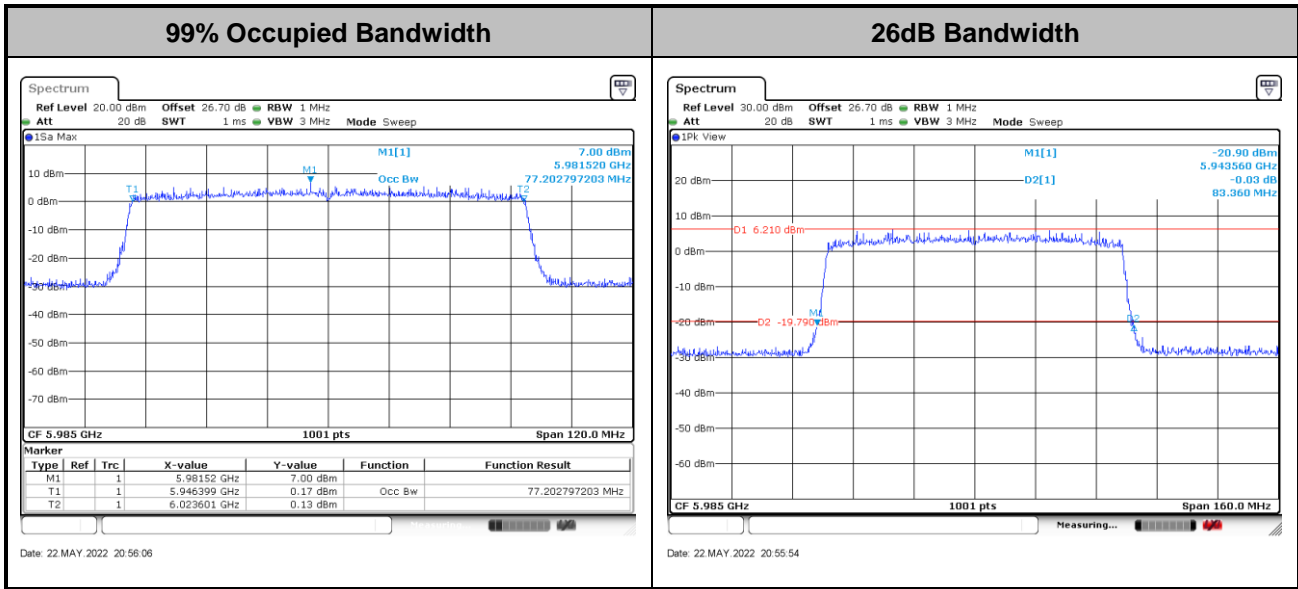

Note: The occupied channel bandwidth is maintained within the band of operation for all of the modulations.

<802.11ax HE160>

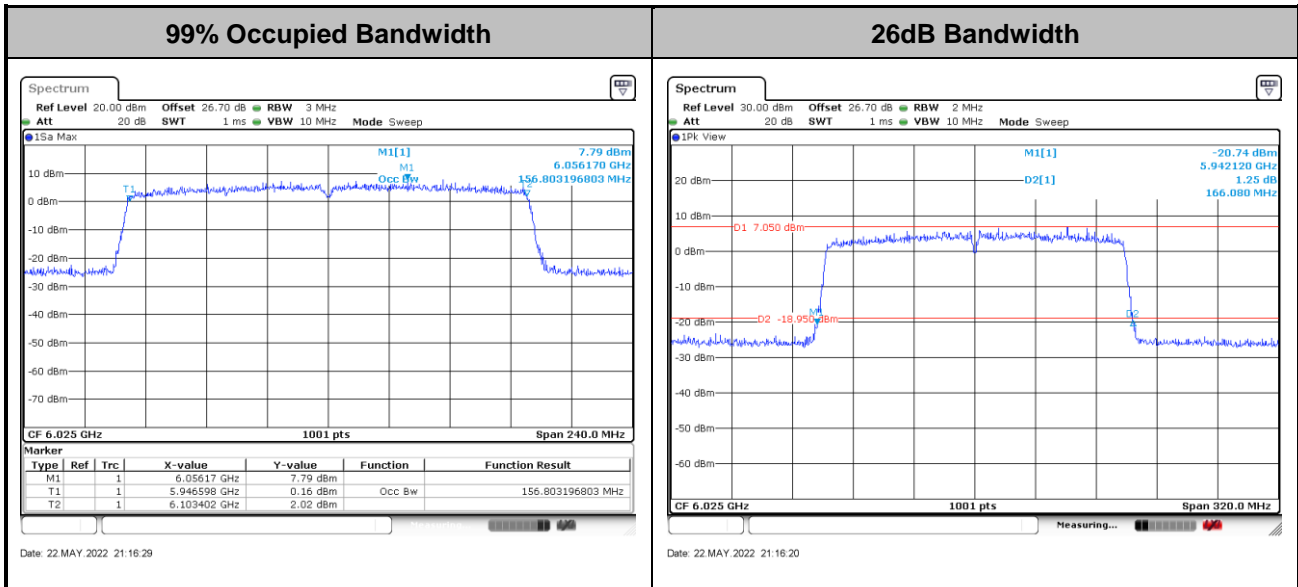

Note: The occupied channel bandwidth is maintained within the band of operation for all of the modulations.



<CDD Mode>

<Indoor Client>

Band VI MIMO									
Mod.	Data Rate	NTX	CH.	Freq. (MHz)	99% Bandwidth (MHz)		26 dB Bandwidth (MHz)		Note
					Ant 9	Ant 8	Ant 9	Ant 8	
11a	6Mbps	2	097	6435	16.38	16.38	19.65	19.35	-
11a	6Mbps	2	105	6475	16.38	16.38	19.40	19.50	-
11a	6Mbps	2	113	6515	16.43	16.38	19.80	19.50	-

Band VIII MIMO									
Mod.	Data Rate	NTX	CH.	Freq. (MHz)	99% Bandwidth (MHz)		26 dB Bandwidth (MHz)		Note
					Ant 9	Ant 8	Ant 9	Ant 8	
11a	6Mbps	2	189	6895	16.43	16.38	19.55	19.50	-
11a	6Mbps	2	209	6995	16.43	16.43	19.50	19.45	-
11a	6Mbps	2	229	7095	16.43	16.43	19.40	19.50	-
11a	6Mbps	2	233	7115	16.38	16.43	19.60	19.55	-

Band VIII straddle channel MIMO									
Mod.	Data Rate	NTX	CH.	Freq. (MHz)	99% Bandwidth (MHz)		26 dB Bandwidth (MHz)		Note
					Ant 9	Ant 8	Ant 9	Ant 8	
11a	6Mbps	2	185	6875	16.43	16.38	19.60	19.35	-



<802.11a>

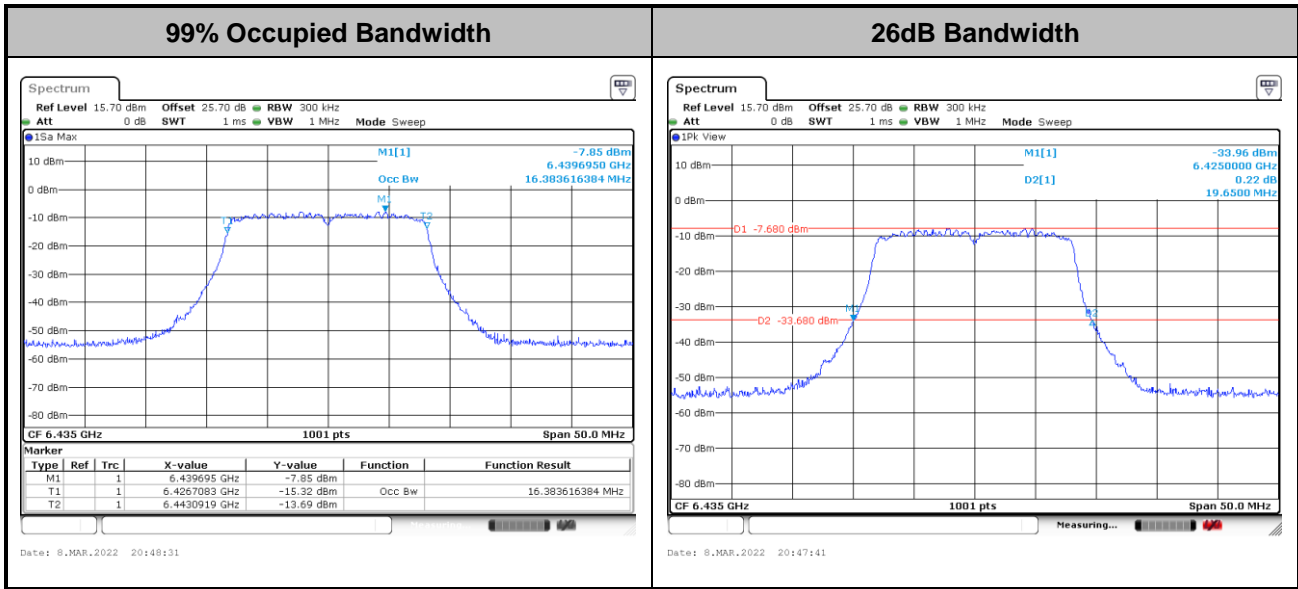

Note: The occupied channel bandwidth is maintained within the band of operation for all of the modulations.



<Standard Client>

Band V MIMO									
Mod.	Data Rate	NTX	CH.	Freq. (MHz)	99% Bandwidth (MHz)		26 dB Bandwidth (MHz)		Note
					Ant 9	Ant 8	Ant 9	Ant 8	
11a	6Mbps	2	001	5955	16.38	16.43	19.85	19.85	-
11a	6Mbps	2	049	6195	16.43	16.43	20.00	19.85	-
11a	6Mbps	2	093	6415	16.43	16.38	19.95	19.75	-

Band VII MIMO									
Mod.	Data Rate	NTX	CH.	Freq. (MHz)	99% Bandwidth (MHz)		26 dB Bandwidth (MHz)		Note
					Ant 9	Ant 8	Ant 9	Ant 8	
11a	6Mbps	2	117	6535	16.43	16.38	20.50	19.75	-
11a	6Mbps	2	149	6695	16.43	16.38	20.60	20.75	-
11a	6Mbps	2	181	6855	16.43	16.38	21.10	20.10	-



<802.11a>

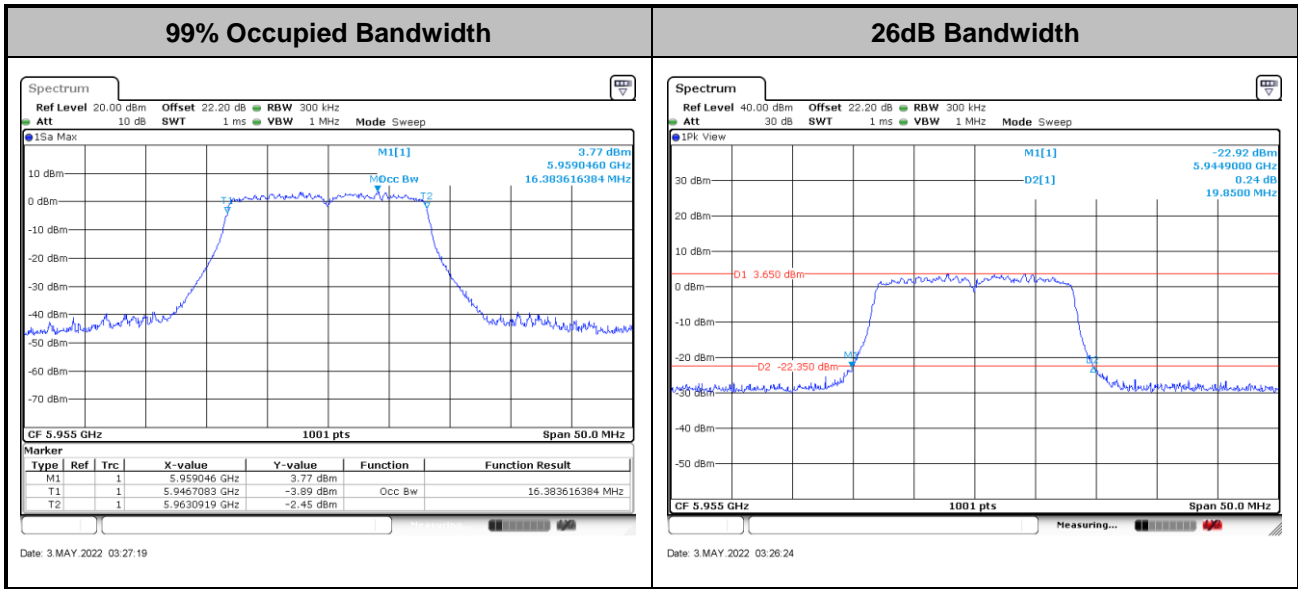

Note: The occupied channel bandwidth is maintained within the band of operation for all of the modulations.



3.2 Fundamental Maximum EIRP Measurement

3.2.1 Limit of Fundamental Maximum EIRP

<FCC 14-30 CFR 15.407>

(a)(7) For client devices, except for fixed client devices as defined in this subpart, operating under the control of a standard power access

point in 5.925-6.425 GHz and 6.525-6.875 GHz bands, the maximum power spectral density must not exceed 17 dBm e.i.r.p. in any 1-

megahertz band, and the maximum e.i.r.p. over the frequency band of operation must not exceed 30 dBm and the device must limit its

power to no more than 6 dB below its associated standard power access point's authorized transmit power.

(a)(8) For client devices operating under the control of an indoor access point in the 5.925-7.125 GHz bands, the maximum e.i.r.p. over the frequency band of operation must not exceed 24 dBm.

3.2.2 Measuring Instruments

Please refer to the measuring equipment list in this test report.

3.2.3 Test Procedures

<CDD and SDM Modes>

The testing follows Method PM-G of FCC KDB 789033 D02 General UNII Test Procedures New Rules v02r01.

Method PM-G (Measurement using a gated RF average power meter):

1. Measurement is performed using a wideband RF power meter.
2. The EUT is configured to transmit at its maximum power control level.
3. Measure the average power of the transmitter.
4. Since the measurement is made only during the ON time of the transmitter, no duty cycle correction factor is required.
5. For MIMO mode, calculation method follows FCC KDB 662911 D01 Multiple Transmitter Output v02r01.

<TXBF Modes>

The testing follows Method PM-G of FCC KDB 789033 D02 General UNII Test Procedures New Rules v02r01.

Method PM-G (Measurement using a gated RF average power meter):

1. Measurement is performed using a wideband RF power meter.
2. The EUT is configured to transmit at its maximum power control level.
3. Measure the average power of the transmitter
4. Since the measurement is made only during the ON time of the transmitter, no duty cycle correction factor is required.
5. For MIMO mode, calculation method follows FCC KDB 662911 D01 Multiple Transmitter Output v02r01.

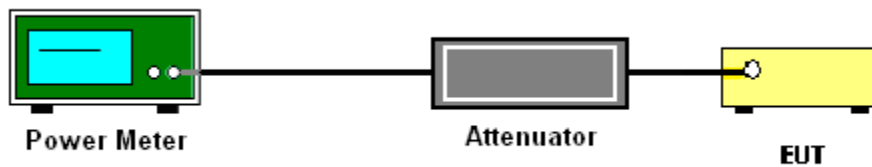
3.2.4 Test Setup



3.2.5 Test Result of Fundamental Maximum EIRP

Test Engineer :	Jacob Yu, Hank Hsu and Junyu Jhou	Temperature :	17.7~22.5°C
		Relative Humidity :	45.1~61.9%

<SDM Mode>

<Indoor Client>

FCC Band V MIMO												
Mod.	Data Rate	NTX	CH.	Freq. (MHz)	Conducted Power (dBm)			DG (dBi)		EIRP Power (dBm)	EIRP Power Limit (dBm)	Pass /Fail
					Ant 9	Ant 8	SUM	Ant 9	Ant 8			
HT20	MCS8	2	001	5955	4.90	4.50	7.71	3.56	11.27	24.00	Pass	
HT20	MCS8	2	049	6195	5.00	4.30	7.67	3.56	11.23	24.00	Pass	
HT20	MCS8	2	093	6415	4.60	4.40	7.51	3.56	11.07	24.00	Pass	
HT40	MCS8	2	003	5965	7.60	7.10	10.37	3.56	13.93	24.00	Pass	
HT40	MCS8	2	051	6205	7.60	7.00	10.32	3.56	13.88	24.00	Pass	
HT40	MCS8	2	091	6405	7.30	7.20	10.26	3.56	13.82	24.00	Pass	
VHT20	MCS0	2	001	5955	4.90	4.50	7.71	3.56	11.27	24.00	Pass	
VHT20	MCS0	2	049	6195	5.00	4.30	7.67	3.56	11.23	24.00	Pass	
VHT20	MCS0	2	093	6415	4.60	4.40	7.51	3.56	11.07	24.00	Pass	
VHT40	MCS0	2	003	5965	7.60	7.10	10.37	3.56	13.93	24.00	Pass	
VHT40	MCS0	2	051	6205	7.60	7.00	10.32	3.56	13.88	24.00	Pass	
VHT40	MCS0	2	091	6405	7.30	7.20	10.26	3.56	13.82	24.00	Pass	
VHT80	MCS0	2	007	5985	10.50	10.00	13.27	3.56	16.83	24.00	Pass	
VHT80	MCS0	2	055	6225	10.60	10.20	13.41	3.56	16.97	24.00	Pass	
VHT80	MCS0	2	087	6385	10.40	10.00	13.21	3.56	16.77	24.00	Pass	
VHT160	MCS0	2	015	6025	12.30	12.30	15.31	3.56	18.87	24.00	Pass	
VHT160	MCS0	2	047	6185	12.30	11.80	15.07	3.56	18.63	24.00	Pass	
VHT160	MCS0	2	079	6345	12.00	12.00	15.01	3.56	18.57	24.00	Pass	



FCC Band VI MIMO												
Mod.	Data Rate	NTX	CH.	Freq. (MHz)	Conducted Power (dBm)			DG (dBi)		EIRP Power (dBm)	EIRP Power Limit (dBm)	Pass /Fail
					Ant 9	Ant 8	SUM	Ant 9	Ant 8	SUM		
HT20	MCS8	2	097	6435	4.60	4.40	7.51	3.56	11.07	24.00	Pass	
HT20	MCS8	2	105	6475	4.00	4.10	7.06	3.56	10.62	24.00	Pass	
HT20	MCS8	2	113	6515	4.50	4.30	7.41	3.56	10.97	24.00	Pass	
HT40	MCS8	2	099	6445	7.10	7.20	10.16	3.56	13.72	24.00	Pass	
HT40	MCS8	2	107	6485	7.20	7.50	10.36	3.56	13.92	24.00	Pass	
VHT20	MCS0	2	097	6435	4.60	4.40	7.51	3.56	11.07	24.00	Pass	
VHT20	MCS0	2	105	6475	4.00	4.10	7.06	3.56	10.62	24.00	Pass	
VHT20	MCS0	2	113	6515	4.50	4.30	7.41	3.56	10.97	24.00	Pass	
VHT40	MCS0	2	099	6445	7.10	7.20	10.16	3.56	13.72	24.00	Pass	
VHT40	MCS0	2	107	6485	7.20	7.50	10.36	3.56	13.92	24.00	Pass	
VHT80	MCS0	2	103	6465	10.00	9.80	12.91	3.56	16.47	24.00	Pass	

FCC Band VI straddle channel MIMO												
Mod.	Data Rate	NTX	CH.	Freq. (MHz)	Conducted Power (dBm)			DG (dBi)		EIRP Power (dBm)	EIRP Power Limit (dBm)	Pass /Fail
					Ant 9	Ant 8	SUM	Ant 9	Ant 8	SUM		
HT40	MCS8	2	115	6525	7.40	7.60	10.51	3.56	14.07	24.00	Pass	
VHT40	MCS0	2	115	6525	7.40	7.60	10.51	3.56	14.07	24.00	Pass	
VHT80	MCS0	2	119	6545	10.10	10.40	13.26	3.56	16.82	24.00	Pass	
VHT160	MCS0	2	111	6505	11.40	12.70	15.11	3.56	18.67	24.00	Pass	



FCC Band VII MIMO												
Mod.	Data Rate	NTX	CH.	Freq. (MHz)	Conducted Power (dBm)			DG (dBi)		EIRP Power (dBm)	EIRP Power Limit (dBm)	Pass /Fail
					Ant 9	Ant 8	SUM	Ant 9	Ant 8			
HT20	MCS8	2	117	6535	3.80	4.10	6.96	3.56	10.52	24.00	Pass	
HT20	MCS8	2	149	6695	4.40	4.20	7.31	3.56	10.87	24.00	Pass	
HT20	MCS8	2	181	6855	4.80	4.20	7.52	3.56	11.08	24.00	Pass	
HT40	MCS8	2	123	6565	7.10	7.20	10.16	3.56	13.72	24.00	Pass	
HT40	MCS8	2	147	6685	7.40	6.90	10.17	3.56	13.73	24.00	Pass	
HT40	MCS8	2	179	6845	7.50	7.20	10.36	3.56	13.92	24.00	Pass	
VHT20	MCS0	2	117	6535	3.80	4.10	6.96	3.56	10.52	24.00	Pass	
VHT20	MCS0	2	149	6695	4.40	4.20	7.31	3.56	10.87	24.00	Pass	
VHT20	MCS0	2	181	6855	4.80	4.20	7.52	3.56	11.08	24.00	Pass	
VHT40	MCS0	2	123	6565	7.10	7.20	10.16	3.56	13.72	24.00	Pass	
VHT40	MCS0	2	147	6685	7.40	6.90	10.17	3.56	13.73	24.00	Pass	
VHT40	MCS0	2	179	6845	7.50	7.20	10.36	3.56	13.92	24.00	Pass	
VHT80	MCS0	2	135	6625	10.40	10.10	13.26	3.56	16.82	24.00	Pass	
VHT80	MCS0	2	151	6705	10.30	9.90	13.11	3.56	16.67	24.00	Pass	
VHT80	MCS0	2	167	6785	10.50	10.00	13.27	3.56	16.83	24.00	Pass	
VHT160	MCS0	2	143	6665	11.60	11.70	14.66	3.56	18.22	24.00	Pass	
VHT160	MCS0	2	175	6825	11.20	11.70	14.47	3.56	18.03	24.00	Pass	



FCC Band VIII MIMO												
Mod.	Data Rate	NTX	CH.	Freq. (MHz)	Conducted Power (dBm)			DG (dBi)		EIRP Power (dBm)	EIRP Power Limit (dBm)	Pass /Fail
					Ant 9	Ant 8	SUM	Ant 9	Ant 8			
HT20	MCS8	2	189	6895	4.10	4.00	7.06	3.95	11.01	24.00	Pass	
HT20	MCS8	2	209	6995	4.40	4.00	7.21	3.95	11.16	24.00	Pass	
HT20	MCS8	2	229	7095	5.60	4.90	8.27	3.95	12.22	24.00	Pass	
HT20	MCS8	2	233	7115	-5.20	-5.80	-2.48	3.95	1.47	24.00	Pass	
HT40	MCS8	2	195	6925	7.30	7.00	10.16	3.95	14.11	24.00	Pass	
HT40	MCS8	2	211	7005	7.40	7.10	10.26	3.95	14.21	24.00	Pass	
HT40	MCS8	2	227	7085	7.90	7.30	10.62	3.95	14.57	24.00	Pass	
VHT20	MCS0	2	189	6895	4.10	4.00	7.06	3.95	11.01	24.00	Pass	
VHT20	MCS0	2	209	6995	4.40	4.00	7.21	3.95	11.16	24.00	Pass	
VHT20	MCS0	2	229	7095	5.60	4.90	8.27	3.95	12.22	24.00	Pass	
VHT20	MCS0	2	233	7115	-5.20	-5.80	-2.48	3.95	1.47	24.00	Pass	
VHT40	MCS0	2	195	6925	7.30	7.00	10.16	3.95	14.11	24.00	Pass	
VHT40	MCS0	2	211	7005	7.40	7.10	10.26	3.95	14.21	24.00	Pass	
VHT40	MCS0	2	227	7085	7.90	7.30	10.62	3.95	14.57	24.00	Pass	
VHT80	MCS0	2	199	6945	10.20	10.10	13.16	3.95	17.11	24.00	Pass	
VHT80	MCS0	2	215	7025	10.80	10.30	13.57	3.95	17.52	24.00	Pass	
VHT160	MCS0	2	207	6985	10.70	11.60	14.18	3.95	18.13	24.00	Pass	



FCC Band VIII straddle channel MIMO												
Mod.	Data Rate	NTX	CH.	Freq. (MHz)	Conducted Power (dBm)			DG (dBi)		EIRP Power (dBm)	EIRP Power Limit (dBm)	Pass /Fail
					Ant 9	Ant 8	SUM	Ant 9	Ant 8	SUM		
HT20	MCS8	2	185	6875	4.60	4.50	7.56	3.95		11.51	24.00	Pass
HT40	MCS8	2	187	6885	7.30	7.40	10.36	3.95		14.31	24.00	Pass
VHT20	MCS0	2	185	6875	4.60	4.50	7.56	3.95		11.51	24.00	Pass
VHT40	MCS0	2	187	6885	7.30	7.40	10.36	3.95		14.31	24.00	Pass
VHT80	MCS0	2	183	6865	10.20	10.20	13.21	3.95		17.16	24.00	Pass
VHT160	MCS0	2	175	6825	11.20	11.70	14.47	3.95		18.42	24.00	Pass

FCC Band V MIMO													
Mod.	Data Rate	NTX	CH.	Freq. (MHz)	RU Config.	Conducted Power (dBm)			DG (dBi)		EIRP Power (dBm)	EIRP Power Limit (dBm)	Pass /Fail
						Ant 9	Ant 8	SUM	Ant 9	Ant 8	SUM		
HE20	MCS0	2	001	5955	Full	5.00	4.60	7.81	3.56		11.37	24.00	Pass
HE20	MCS0	2	049	6195	Full	5.10	4.40	7.77	3.56		11.33	24.00	Pass
HE20	MCS0	2	093	6415	Full	4.70	4.50	7.61	3.56		11.17	24.00	Pass
HE40	MCS0	2	003	5965	Full	7.70	7.20	10.47	3.56		14.03	24.00	Pass
HE40	MCS0	2	051	6205	Full	7.70	7.10	10.42	3.56		13.98	24.00	Pass
HE40	MCS0	2	091	6405	Full	7.40	7.30	10.36	3.56		13.92	24.00	Pass
HE80	MCS0	2	007	5985	Full	10.60	10.10	13.37	3.56		16.93	24.00	Pass
HE80	MCS0	2	055	6225	Full	10.70	10.30	13.51	3.56		17.07	24.00	Pass
HE80	MCS0	2	087	6385	Full	10.50	10.10	13.31	3.56		16.87	24.00	Pass
HE160	MCS0	2	015	6025	Full	12.40	12.40	15.41	3.56		18.97	24.00	Pass
HE160	MCS0	2	047	6185	Full	12.40	11.90	15.17	3.56		18.73	24.00	Pass
HE160	MCS0	2	079	6345	Full	12.10	12.10	15.11	3.56		18.67	24.00	Pass



FCC Band VI MIMO													
Mod.	Data Rate	NTX	CH.	Freq. (MHz)	RU Config.	Conducted Power (dBm)			DG (dBi)		EIRP Power (dBm)	EIRP Power Limit (dBm)	Pass /Fail
						Ant 9	Ant 8	SUM	Ant 9	Ant 8	SUM		
HE20	MCS0	2	097	6435	Full	4.70	4.50	7.61	3.56		11.17	24.00	Pass
HE20	MCS0	2	105	6475	Full	4.10	4.20	7.16	3.56		10.72	24.00	Pass
HE20	MCS0	2	113	6515	Full	4.60	4.40	7.51	3.56		11.07	24.00	Pass
HE40	MCS0	2	099	6445	Full	7.20	7.30	10.26	3.56		13.82	24.00	Pass
HE40	MCS0	2	107	6485	Full	7.30	7.60	10.46	3.56		14.02	24.00	Pass
HE80	MCS0	2	103	6465	Full	10.10	9.90	13.01	3.56		16.57	24.00	Pass

FCC Band VI straddle channel MIMO													
Mod.	Data Rate	NTX	CH.	Freq. (MHz)	RU Config.	Conducted Power (dBm)			DG (dBi)		EIRP Power (dBm)	EIRP Power Limit (dBm)	Pass /Fail
						Ant 9	Ant 8	SUM	Ant 9	Ant 8	SUM		
HE40	MCS0	2	115	6525	Full	7.30	7.50	10.41	3.56		13.97	24.00	Pass
HE80	MCS0	2	119	6545	Full	10.20	10.50	13.36	3.56		16.92	24.00	Pass
HE160	MCS0	2	111	6505	Full	11.10	12.50	14.87	3.56		18.43	24.00	Pass



FCC Band VII MIMO													
Mod.	Data Rate	NTX	CH.	Freq. (MHz)	RU Config.	Conducted Power (dBm)			DG (dBi)		EIRP Power (dBm)	EIRP Power Limit (dBm)	Pass /Fail
						Ant 9	Ant 8	SUM	Ant 9	Ant 8	SUM		
HE20	MCS0	2	117	6535	Full	3.90	4.20	7.06	3.56	10.62	24.00	Pass	
HE20	MCS0	2	149	6695	Full	4.50	4.30	7.41	3.56	10.97	24.00	Pass	
HE20	MCS0	2	181	6855	Full	4.90	4.30	7.62	3.56	11.18	24.00	Pass	
HE40	MCS0	2	123	6565	Full	7.20	7.30	10.26	3.56	13.82	24.00	Pass	
HE40	MCS0	2	147	6685	Full	7.50	7.00	10.27	3.56	13.83	24.00	Pass	
HE40	MCS0	2	179	6845	Full	7.60	7.30	10.46	3.56	14.02	24.00	Pass	
HE80	MCS0	2	135	6625	Full	10.50	10.20	13.36	3.56	16.92	24.00	Pass	
HE80	MCS0	2	151	6705	Full	10.40	10.00	13.21	3.56	16.77	24.00	Pass	
HE80	MCS0	2	167	6785	Full	10.60	10.10	13.37	3.56	16.93	24.00	Pass	
HE160	MCS0	2	143	6665	Full	11.70	11.80	14.76	3.56	18.32	24.00	Pass	



Band VIII MIMO													
Mod.	Data Rate	NTX	CH.	Freq. (MHz)	RU Config.	Conducted Power (dBm)			DG (dBi)		EIRP Power (dBm)	EIRP Power Limit (dBm)	Pass /Fail
						Ant 9	Ant 8	SUM	Ant 9	Ant 8	SUM		
HE20	MCS0	2	189	6895	Full	4.20	4.10	7.16	3.95		11.11	24.00	Pass
HE20	MCS0	2	209	6995	Full	4.50	4.10	7.31	3.95		11.26	24.00	Pass
HE20	MCS0	2	229	7095	Full	5.70	5.00	8.37	3.95		12.32	24.00	Pass
HE20	MCS0	2	233	7115	Full	-5.10	-5.70	-2.38	3.95		1.57	24.00	Pass
HE40	MCS0	2	195	6925	Full	7.40	7.10	10.26	3.95		14.21	24.00	Pass
HE40	MCS0	2	211	7005	Full	7.50	7.20	10.36	3.95		14.31	24.00	Pass
HE40	MCS0	2	227	7085	Full	8.00	7.40	10.72	3.95		14.67	24.00	Pass
HE80	MCS0	2	199	6945	Full	10.30	10.20	13.26	3.95		17.21	24.00	Pass
HE80	MCS0	2	215	7025	Full	10.90	10.40	13.67	3.95		17.62	24.00	Pass
HE160	MCS0	2	207	6985	Full	10.80	11.70	14.28	3.95		18.23	24.00	Pass

FCC Band VIII straddle channel MIMO													
Mod.	Data Rate	NTX	CH.	Freq. (MHz)	RU Config.	Conducted Power (dBm)			DG (dBi)		EIRP Power (dBm)	EIRP Power Limit (dBm)	Pass /Fail
						Ant 9	Ant 8	SUM	Ant 9	Ant 8	SUM		
HE20	MCS0	2	185	6875	Full	4.40	4.30	7.36	3.95		11.31	24.00	Pass
HE40	MCS0	2	187	6885	Full	7.10	7.20	10.16	3.95		14.11	24.00	Pass
HE80	MCS0	2	183	6865	Full	10.30	10.30	13.31	3.95		17.26	24.00	Pass
HE160	MCS0	2	175	6825	Full	11.30	11.80	14.57	3.95		18.52	24.00	Pass



<SDM Mode>

<Standard Client>

FCC Band V MIMO												
Mod.	Data Rate	NTX	CH.	Freq. (MHz)	Conducted Power (dBm)			DG (dBi)		EIRP Power (dBm)	EIRP Power Limit (dBm)	Pass /Fail
					Ant 9	Ant 8	SUM	Ant 9	Ant 8	SUM		
HT20	MCS8	2	001	5955	12.20	12.00	15.11	3.56		18.67	30.00	Pass
HT20	MCS8	2	049	6195	12.40	11.30	14.90	3.56		18.46	30.00	Pass
HT20	MCS8	2	093	6415	12.10	12.40	15.26	3.56		18.82	30.00	Pass
HT40	MCS8	2	003	5965	12.40	12.20	15.31	3.56		18.87	30.00	Pass
HT40	MCS8	2	051	6205	12.30	11.30	14.84	3.56		18.40	30.00	Pass
HT40	MCS8	2	091	6405	12.10	12.30	15.21	3.56		18.77	30.00	Pass
VHT20	MCS0	2	001	5955	12.20	12.00	15.11	3.56		18.67	30.00	Pass
VHT20	MCS0	2	049	6195	12.40	11.30	14.90	3.56		18.46	30.00	Pass
VHT20	MCS0	2	093	6415	12.10	12.40	15.26	3.56		18.82	30.00	Pass
VHT40	MCS0	2	003	5965	12.40	12.20	15.31	3.56		18.87	30.00	Pass
VHT40	MCS0	2	051	6205	12.30	11.30	14.84	3.56		18.40	30.00	Pass
VHT40	MCS0	2	091	6405	12.10	12.30	15.21	3.56		18.77	30.00	Pass
VHT80	MCS0	2	007	5985	12.30	11.80	15.07	3.56		18.63	30.00	Pass
VHT80	MCS0	2	055	6225	12.40	11.90	15.17	3.56		18.73	30.00	Pass
VHT80	MCS0	2	087	6385	12.30	12.40	15.36	3.56		18.92	30.00	Pass
VHT160	MCS0	2	015	6025	12.30	11.80	15.07	3.56		18.63	30.00	Pass
VHT160	MCS0	2	047	6185	12.30	11.40	14.88	3.56		18.44	30.00	Pass
VHT160	MCS0	2	079	6345	12.10	12.00	15.06	3.56		18.62	30.00	Pass



FCC Band VII MIMO												
Mod.	Data Rate	NTX	CH.	Freq. (MHz)	Conducted Power (dBm)			DG (dBi)		EIRP Power (dBm)	EIRP Power Limit (dBm)	Pass /Fail
					Ant 9	Ant 8	SUM	Ant 9	Ant 8	SUM		
HT20	MCS8	2	117	6535	10.90	11.90	14.44	3.56		18.00	30.00	Pass
HT20	MCS8	2	149	6695	11.60	11.70	14.66	3.56		18.22	30.00	Pass
HT20	MCS8	2	181	6855	11.80	11.60	14.71	3.56		18.27	30.00	Pass
HT40	MCS8	2	123	6565	11.30	11.80	14.57	3.56		18.13	30.00	Pass
HT40	MCS8	2	147	6685	11.70	11.70	14.71	3.56		18.27	30.00	Pass
HT40	MCS8	2	179	6845	11.90	11.90	14.91	3.56		18.47	30.00	Pass
VHT20	MCS0	2	117	6535	10.90	11.90	14.44	3.56		18.00	30.00	Pass
VHT20	MCS0	2	149	6695	11.60	11.70	14.66	3.56		18.22	30.00	Pass
VHT20	MCS0	2	181	6855	11.80	11.60	14.71	3.56		18.27	30.00	Pass
VHT40	MCS0	2	123	6565	11.30	11.80	14.57	3.56		18.13	30.00	Pass
VHT40	MCS0	2	147	6685	11.70	11.70	14.71	3.56		18.27	30.00	Pass
VHT40	MCS0	2	179	6845	11.90	11.90	14.91	3.56		18.47	30.00	Pass
VHT80	MCS0	2	135	6625	11.30	11.80	14.57	3.56		18.13	30.00	Pass
VHT80	MCS0	2	151	6705	11.40	11.60	14.51	3.56		18.07	30.00	Pass
VHT80	MCS0	2	167	6785	11.90	11.80	14.86	3.56		18.42	30.00	Pass
VHT160	MCS0	2	143	6665	11.10	11.80	14.47	3.56		18.03	30.00	Pass
VHT160	MCS0	2	175	6825	11.90	11.70	14.81	3.56		18.37	30.00	Pass



FCC Band V MIMO													
Mod.	Data Rate	NTX	CH.	Freq. (MHz)	RU Config.	Conducted Power (dBm)			DG (dBi)		EIRP Power (dBm)	EIRP Power Limit (dBm)	Pass /Fail
						Ant 9	Ant 8	SUM	Ant 9	Ant 8	SUM		
HE20	MCS0	2	001	5955	Full	12.30	12.10	15.21	3.56		18.77	30.00	Pass
HE20	MCS0	2	001	5955	26/0	2.70	2.00	5.37	3.56		8.93	30.00	Pass
HE20	MCS0	2	001	5955	52/37	5.30	5.40	8.36	3.56		11.92	30.00	Pass
HE20	MCS0	2	001	5955	106/53	8.40	8.40	11.41	3.56		14.97	30.00	Pass
HE20	MCS0	2	049	6195	Full	12.50	11.40	15.00	3.56		18.56	30.00	Pass
HE20	MCS0	2	049	6195	26/4	3.50	3.00	6.27	3.56		9.83	30.00	Pass
HE20	MCS0	2	049	6195	52/39	5.40	4.60	8.03	3.56		11.59	30.00	Pass
HE20	MCS0	2	049	6195	106/53	8.70	7.90	11.33	3.56		14.89	30.00	Pass
HE20	MCS0	2	093	6415	Full	12.20	12.50	15.36	3.56		18.92	30.00	Pass
HE20	MCS0	2	093	6415	26/8	2.10	3.10	5.64	3.56		9.20	30.00	Pass
HE20	MCS0	2	093	6415	52/40	5.00	5.90	8.48	3.56		12.04	30.00	Pass
HE20	MCS0	2	093	6415	106/54	8.20	9.10	11.68	3.56		15.24	30.00	Pass
HE40	MCS0	2	003	5965	Full	12.50	12.30	15.41	3.56		18.97	30.00	Pass
HE40	MCS0	2	003	5965	242/61	9.20	9.30	12.26	3.56		15.82	30.00	Pass
HE40	MCS0	2	051	6205	Full	12.40	11.40	14.94	3.56		18.50	30.00	Pass
HE40	MCS0	2	051	6205	242/61	9.20	8.40	11.83	3.56		15.39	30.00	Pass
HE40	MCS0	2	091	6405	Full	12.20	12.40	15.31	3.56		18.87	30.00	Pass
HE40	MCS0	2	091	6405	242/62	8.80	9.40	12.12	3.56		15.68	30.00	Pass
HE80	MCS0	2	007	5985	Full	12.40	11.90	15.17	3.56		18.73	30.00	Pass
HE80	MCS0	2	007	5985	484/65	9.10	9.10	12.11	3.56		15.67	30.00	Pass
HE80	MCS0	2	055	6225	Full	12.50	12.00	15.27	3.56		18.83	30.00	Pass
HE80	MCS0	2	055	6225	484/65	9.40	9.10	12.26	3.56		15.82	30.00	Pass
HE80	MCS0	2	087	6385	Full	12.40	12.50	15.46	3.56		19.02	30.00	Pass
HE80	MCS0	2	087	6385	484/66	9.40	9.30	12.36	3.56		15.92	30.00	Pass
HE160	MCS0	2	015	6025	Full	12.40	11.90	15.17	3.56		18.73	30.00	Pass
HE160	MCS0	2	015	6025	996/67	9.40	9.40	12.41	3.56		15.97	30.00	Pass
HE160	MCS0	2	047	6185	Full	12.40	11.50	14.98	3.56		18.54	30.00	Pass
HE160	MCS0	2	047	6185	996/67	9.50	9.20	12.36	3.56		15.92	30.00	Pass
HE160	MCS0	2	079	6345	Full	12.20	12.10	15.16	3.56		18.72	30.00	Pass
HE160	MCS0	2	079	6345	996/S67	9.30	9.10	12.21	3.56		15.77	30.00	Pass



FCC Band VII MIMO													
Mod.	Data Rate	NTX	CH.	Freq. (MHz)	RU Config.	Conducted Power (dBm)			DG (dBi)		EIRP Power (dBm)	EIRP Power Limit (dBm)	Pass /Fail
						Ant 9	Ant 8	SUM	Ant 9	Ant 8	SUM		
HE20	MCS0	2	117	6535	Full	11.00	12.00	14.54	3.56		18.10	30.00	Pass
HE20	MCS0	2	117	6535	26/0	1.80	2.60	5.23	3.56		8.79	30.00	Pass
HE20	MCS0	2	117	6535	52/37	4.70	5.90	8.35	3.56		11.91	30.00	Pass
HE20	MCS0	2	117	6535	106/53	7.20	8.20	10.74	3.56		14.30	30.00	Pass
HE20	MCS0	2	149	6695	Full	11.70	11.80	14.76	3.56		18.32	30.00	Pass
HE20	MCS0	2	149	6695	26/4	2.40	3.10	5.77	3.56		9.33	30.00	Pass
HE20	MCS0	2	149	6695	52/38	4.60	4.80	7.71	3.56		11.27	30.00	Pass
HE20	MCS0	2	149	6695	106/53	7.80	8.20	11.01	3.56		14.57	30.00	Pass
HE20	MCS0	2	181	6855	Full	11.90	11.70	14.81	3.56		18.37	30.00	Pass
HE20	MCS0	2	181	6855	26/8	2.30	1.40	4.88	3.56		8.44	30.00	Pass
HE20	MCS0	2	181	6855	52/40	4.40	4.60	7.51	3.56		11.07	30.00	Pass
HE20	MCS0	2	181	6855	106/54	8.00	7.90	10.96	3.56		14.52	30.00	Pass
HE40	MCS0	2	123	6565	Full	11.40	11.90	14.67	3.56		18.23	30.00	Pass
HE40	MCS0	2	123	6565	242/61	8.30	9.10	11.73	3.56		15.29	30.00	Pass
HE40	MCS0	2	147	6685	Full	11.70	11.80	14.76	3.56		18.32	30.00	Pass
HE40	MCS0	2	147	6685	242/61	8.50	8.80	11.66	3.56		15.22	30.00	Pass
HE40	MCS0	2	179	6845	Full	12.00	12.00	15.01	3.56		18.57	30.00	Pass
HE40	MCS0	2	179	6845	242/62	8.10	8.10	11.11	3.56		14.67	30.00	Pass
HE80	MCS0	2	135	6625	Full	11.40	11.90	14.67	3.56		18.23	30.00	Pass
HE80	MCS0	2	135	6625	484/65	8.60	8.60	11.61	3.56		15.17	30.00	Pass
HE80	MCS0	2	151	6705	Full	11.50	11.70	14.61	3.56		18.17	30.00	Pass
HE80	MCS0	2	151	6705	484/65	8.50	8.70	11.61	3.56		15.17	30.00	Pass
HE80	MCS0	2	167	6785	Full	12.00	11.90	14.96	3.56		18.52	30.00	Pass
HE80	MCS0	2	167	6785	484/66	9.00	8.90	11.96	3.56		15.52	30.00	Pass
HE160	MCS0	2	143	6665	Full	11.20	11.90	14.57	3.56		18.13	30.00	Pass
HE160	MCS0	2	143	6665	996/67	8.50	8.90	11.71	3.56		15.27	30.00	Pass
HE160	MCS0	2	175	6825	Full	12.00	11.80	14.91	3.56		18.47	30.00	Pass
HE160	MCS0	2	175	6825	996/S67	8.70	8.60	11.66	3.56		15.22	30.00	Pass



<CDD Mode>

<Indoor Client>

FCC Band V MIMO												
Mod.	Data Rate	NTX	CH.	Freq. (MHz)	Conducted Power (dBm)			DG (dBi)		EIRP Power (dBm)	EIRP Power Limit (dBm)	Pass /Fail
					Ant 9	Ant 8	SUM	Ant 9	Ant 8	SUM		
11a	6Mbps	2	001	5955	0.50	0.90	3.71	3.90	7.61	24.00	Pass	
11a	6Mbps	2	049	6195	1.10	0.50	3.82	3.90	7.72	24.00	Pass	
11a	6Mbps	2	093	6415	0.70	0.40	3.56	3.90	7.46	24.00	Pass	
HT20	MCS0	2	001	5955	0.50	1.20	3.87	3.90	7.77	24.00	Pass	
HT20	MCS0	2	049	6195	1.20	0.70	3.97	3.90	7.87	24.00	Pass	
HT20	MCS0	2	093	6415	1.00	0.90	3.96	3.90	7.86	24.00	Pass	
HT40	MCS0	2	003	5965	4.00	4.00	7.01	3.90	10.91	24.00	Pass	
HT40	MCS0	2	051	6205	4.10	3.50	6.82	3.90	10.72	24.00	Pass	
HT40	MCS0	2	091	6405	3.80	3.80	6.81	3.90	10.71	24.00	Pass	
VHT20	MCS0	2	001	5955	0.50	1.20	3.87	3.90	7.77	24.00	Pass	
VHT20	MCS0	2	049	6195	1.20	0.70	3.97	3.90	7.87	24.00	Pass	
VHT20	MCS0	2	093	6415	1.00	0.90	3.96	3.90	7.86	24.00	Pass	
VHT40	MCS0	2	003	5965	4.00	4.00	7.01	3.90	10.91	24.00	Pass	
VHT40	MCS0	2	051	6205	4.10	3.50	6.82	3.90	10.72	24.00	Pass	
VHT40	MCS0	2	091	6405	3.80	3.80	6.81	3.90	10.71	24.00	Pass	
VHT80	MCS0	2	007	5985	6.80	6.80	9.81	3.90	13.71	24.00	Pass	
VHT80	MCS0	2	055	6225	6.50	6.40	9.46	3.90	13.36	24.00	Pass	
VHT80	MCS0	2	087	6385	6.50	6.70	9.61	3.90	13.51	24.00	Pass	
VHT160	MCS0	2	015	6025	9.00	9.10	12.06	3.90	15.96	24.00	Pass	
VHT160	MCS0	2	047	6185	8.90	8.80	11.86	3.90	15.76	24.00	Pass	
VHT160	MCS0	2	079	6345	8.70	8.80	11.76	3.90	15.66	24.00	Pass	



FCC Band VI MIMO												
Mod.	Data Rate	NTX	CH.	Freq. (MHz)	Conducted Power (dBm)			DG (dBi)		EIRP Power (dBm)	EIRP Power Limit (dBm)	Pass /Fail
					Ant 9	Ant 8	SUM	Ant 9	Ant 8	SUM		
11a	6Mbps	2	097	6435	0.50	1.00	3.77	3.90	7.67	24.00	Pass	
11a	6Mbps	2	105	6475	0.20	0.60	3.41	3.90	7.31	24.00	Pass	
11a	6Mbps	2	113	6515	-0.20	0.80	3.34	3.90	7.24	24.00	Pass	
HT20	MCS0	2	097	6435	0.60	1.20	3.92	3.90	7.82	24.00	Pass	
HT20	MCS0	2	105	6475	0.90	1.40	4.17	3.90	8.07	24.00	Pass	
HT20	MCS0	2	113	6515	0.40	1.40	3.94	3.90	7.84	24.00	Pass	
HT40	MCS0	2	099	6445	3.80	3.70	6.76	3.90	10.66	24.00	Pass	
HT40	MCS0	2	107	6485	3.80	3.90	6.86	3.90	10.76	24.00	Pass	
VHT20	MCS0	2	097	6435	0.60	1.20	3.92	3.90	7.82	24.00	Pass	
VHT20	MCS0	2	105	6475	0.90	1.40	4.17	3.90	8.07	24.00	Pass	
VHT20	MCS0	2	113	6515	0.40	1.40	3.94	3.90	7.84	24.00	Pass	
VHT40	MCS0	2	099	6445	3.80	3.70	6.76	3.90	10.66	24.00	Pass	
VHT40	MCS0	2	107	6485	3.80	3.90	6.86	3.90	10.76	24.00	Pass	
VHT80	MCS0	2	103	6465	6.40	6.60	9.51	3.90	13.41	24.00	Pass	

FCC Band VI straddle channel MIMO												
Mod.	Data Rate	NTX	CH.	Freq. (MHz)	Conducted Power (dBm)			DG (dBi)		EIRP Power (dBm)	EIRP Power Limit (dBm)	Pass /Fail
					Ant 9	Ant 8	SUM	Ant 9	Ant 8	SUM		
HT40	MCS0	2	115	6525	4.00	4.00	7.01	3.90	10.91	24.00	Pass	
VHT40	MCS0	2	115	6525	4.00	4.00	7.01	3.90	10.91	24.00	Pass	
VHT80	MCS0	2	119	6545	6.90	7.10	10.01	3.90	13.91	24.00	Pass	
VHT160	MCS0	2	111	6505	8.30	8.50	11.41	3.90	15.31	24.00	Pass	



FCC Band VII MIMO												
Mod.	Data Rate	NTX	CH.	Freq. (MHz)	Conducted Power (dBm)			DG (dBi)		EIRP Power (dBm)	EIRP Power Limit (dBm)	Pass /Fail
					Ant 9	Ant 8	SUM	Ant 9	Ant 8	SUM		
11a	6Mbps	2	117	6535	0.20	0.40	3.31	3.90		7.21	24.00	Pass
11a	6Mbps	2	149	6695	0.90	-0.10	3.44	3.90		7.34	24.00	Pass
11a	6Mbps	2	181	6855	0.90	0.30	3.62	3.90		7.52	24.00	Pass
HT20	MCS0	2	117	6535	0.90	1.10	4.01	3.90		7.91	24.00	Pass
HT20	MCS0	2	149	6695	1.30	0.50	3.93	3.90		7.83	24.00	Pass
HT20	MCS0	2	181	6855	1.00	0.60	3.81	3.90		7.71	24.00	Pass
HT40	MCS0	2	123	6565	4.30	4.10	7.21	3.90		11.11	24.00	Pass
HT40	MCS0	2	147	6685	4.10	3.70	6.91	3.90		10.81	24.00	Pass
HT40	MCS0	2	179	6845	4.50	3.90	7.22	3.90		11.12	24.00	Pass
VHT20	MCS0	2	117	6535	0.90	1.10	4.01	3.90		7.91	24.00	Pass
VHT20	MCS0	2	149	6695	1.30	0.50	3.93	3.90		7.83	24.00	Pass
VHT20	MCS0	2	181	6855	1.00	0.60	3.81	3.90		7.71	24.00	Pass
VHT40	MCS0	2	123	6565	4.30	4.10	7.21	3.90		11.11	24.00	Pass
VHT40	MCS0	2	147	6685	4.10	3.70	6.91	3.90		10.81	24.00	Pass
VHT40	MCS0	2	179	6845	4.50	3.90	7.22	3.90		11.12	24.00	Pass
VHT80	MCS0	2	135	6625	7.00	6.40	9.72	3.90		13.62	24.00	Pass
VHT80	MCS0	2	151	6705	6.80	6.70	9.76	3.90		13.66	24.00	Pass
VHT80	MCS0	2	167	6785	7.10	6.60	9.87	3.90		13.77	24.00	Pass
VHT160	MCS0	2	143	6665	8.50	8.40	11.46	3.90		15.36	24.00	Pass
VHT160	MCS0	2	175	6825	8.60	8.20	11.41	3.90		15.31	24.00	Pass



FCC Band VIII MIMO												
Mod.	Data Rate	NTX	CH.	Freq. (MHz)	Conducted Power (dBm)			DG (dBi)		EIRP Power (dBm)	EIRP Power Limit (dBm)	Pass /Fail
					Ant 9	Ant 8	SUM	Ant 9	Ant 8	SUM		
11a	6Mbps	2	189	6895	0.40	0.20	3.31	4.00		7.31	24.00	Pass
11a	6Mbps	2	209	6995	0.00	0.40	3.21	4.00		7.21	24.00	Pass
11a	6Mbps	2	229	7095	0.00	0.30	3.16	4.00		7.16	24.00	Pass
11a	6Mbps	2	233	7115	0.40	0.50	3.46	4.00		7.46	24.00	Pass
HT20	MCS0	2	189	6895	0.70	0.30	3.51	4.00		7.51	24.00	Pass
HT20	MCS0	2	209	6995	0.30	0.60	3.46	4.00		7.46	24.00	Pass
HT20	MCS0	2	229	7095	0.60	1.00	3.81	4.00		7.81	24.00	Pass
HT20	MCS0	2	233	7115	-8.30	-8.80	-5.53	4.00		-1.53	24.00	Pass
HT40	MCS0	2	195	6925	3.40	3.60	6.51	4.00		10.51	24.00	Pass
HT40	MCS0	2	211	7005	3.80	3.80	6.81	4.00		10.81	24.00	Pass
HT40	MCS0	2	227	7085	4.10	4.40	7.26	4.00		11.26	24.00	Pass
VHT20	MCS0	2	189	6895	0.70	0.30	3.51	4.00		7.51	24.00	Pass
VHT20	MCS0	2	209	6995	0.30	0.60	3.46	4.00		7.46	24.00	Pass
VHT20	MCS0	2	229	7095	0.60	1.00	3.81	4.00		7.81	24.00	Pass
VHT20	MCS0	2	233	7115	-8.30	-8.80	-5.53	4.00		-1.53	24.00	Pass
VHT40	MCS0	2	195	6925	3.40	3.60	6.51	4.00		10.51	24.00	Pass
VHT40	MCS0	2	211	7005	3.80	3.80	6.81	4.00		10.81	24.00	Pass
VHT40	MCS0	2	227	7085	4.10	4.40	7.26	4.00		11.26	24.00	Pass
VHT80	MCS0	2	199	6945	6.50	6.60	9.56	4.00		13.56	24.00	Pass
VHT80	MCS0	2	215	7025	6.10	6.50	9.31	4.00		13.31	24.00	Pass
VHT160	MCS0	2	207	6985	8.00	8.00	11.01	4.00		15.01	24.00	Pass



FCC Band VIII straddle channel MIMO												
Mod.	Data Rate	NTX	CH.	Freq. (MHz)	Conducted Power (dBm)			DG (dBi)		EIRP Power (dBm)	EIRP Power Limit (dBm)	Pass /Fail
					Ant 9	Ant 8	SUM	Ant 9	Ant 8	SUM		
11a	6Mbps	2	185	6875	0.40	-0.10	3.17	4.00		7.17	24.00	Pass
HT20	MCS0	2	185	6875	1.20	0.70	3.97	4.00		7.97	24.00	Pass
HT40	MCS0	2	187	6885	4.00	3.80	6.91	4.00		10.91	24.00	Pass
VHT20	MCS0	2	185	6875	1.20	0.70	3.97	4.00		7.97	24.00	Pass
VHT40	MCS0	2	187	6885	4.00	3.80	6.91	4.00		10.91	24.00	Pass
VHT80	MCS0	2	183	6865	6.70	6.80	9.76	4.00		13.76	24.00	Pass
VHT160	MCS0	2	175	6825	8.60	8.20	11.41	4.00		15.41	24.00	Pass



FCC Band V MIMO													
Mod.	Data Rate	NTX	CH.	Freq. (MHz)	RU Config.	Conducted Power (dBm)			DG (dBi)		EIRP Power (dBm)	EIRP Power Limit (dBm)	Pass /Fail
						Ant 9	Ant 8	SUM	Ant 9	Ant 8	SUM		
HE20	MCS0	2	001	5955	Full	0.60	1.30	3.97	3.90		7.87	24.00	Pass
HE20	MCS0	2	001	5955	26/0	-8.90	-8.50	-5.69	3.90		-1.79	24.00	Pass
HE20	MCS0	2	001	5955	52/37	-6.60	-6.00	-3.28	3.90		0.62	24.00	Pass
HE20	MCS0	2	001	5955	106/53	-3.50	-3.00	-0.23	3.90		3.67	24.00	Pass
HE20	MCS0	2	049	6195	Full	1.30	0.80	4.07	3.90		7.97	24.00	Pass
HE20	MCS0	2	049	6195	26/4	-7.80	-8.10	-4.94	3.90		-1.04	24.00	Pass
HE20	MCS0	2	049	6195	52/39	-5.70	-6.10	-2.89	3.90		1.01	24.00	Pass
HE20	MCS0	2	049	6195	106/53	-2.70	-3.20	0.07	3.90		3.97	24.00	Pass
HE20	MCS0	2	093	6415	Full	1.10	1.00	4.06	3.90		7.96	24.00	Pass
HE20	MCS0	2	093	6415	26/8	-8.80	-8.80	-5.79	3.90		-1.89	24.00	Pass
HE20	MCS0	2	093	6415	52/40	-5.80	-5.90	-2.84	3.90		1.06	24.00	Pass
HE20	MCS0	2	093	6415	106/54	-2.80	-2.80	0.21	3.90		4.11	24.00	Pass
HE40	MCS0	2	003	5965	Full	4.10	4.10	7.11	3.90		11.01	24.00	Pass
HE40	MCS0	2	003	5965	242/61	1.10	0.90	4.01	3.90		7.91	24.00	Pass
HE40	MCS0	2	051	6205	Full	4.20	3.60	6.92	3.90		10.82	24.00	Pass
HE40	MCS0	2	051	6205	242/61	1.50	0.90	4.22	3.90		8.12	24.00	Pass
HE40	MCS0	2	091	6405	Full	3.90	3.90	6.91	3.90		10.81	24.00	Pass
HE40	MCS0	2	091	6405	242/62	0.20	0.60	3.41	3.90		7.31	24.00	Pass
HE80	MCS0	2	007	5985	Full	6.90	6.90	9.91	3.90		13.81	24.00	Pass
HE80	MCS0	2	007	5985	484/65	2.90	2.70	5.81	3.90		9.71	24.00	Pass
HE80	MCS0	2	055	6225	Full	6.60	6.50	9.56	3.90		13.46	24.00	Pass
HE80	MCS0	2	055	6225	484/65	3.00	2.80	5.91	3.90		9.81	24.00	Pass
HE80	MCS0	2	087	6385	Full	6.60	6.80	9.71	3.90		13.61	24.00	Pass
HE80	MCS0	2	087	6385	484/66	3.30	3.10	6.21	3.90		10.11	24.00	Pass



FCC Band V MIMO													
Mod.	Data Rate	NTX	CH.	Freq. (MHz)	RU Config.	Conducted Power (dBm)			DG (dBi)		EIRP Power (dBm)	EIRP Power Limit (dBm)	Pass /Fail
						Ant 9	Ant 8	SUM	Ant 9	Ant 8	SUM		
HE160	MCS0	2	015	6025	Full	9.10	9.20	12.16	3.90	3.90	16.06	24.00	Pass
HE160	MCS0	2	015	6025	996/67	6.20	6.40	9.31	3.90	3.90	13.21	24.00	Pass
HE160	MCS0	2	047	6185	Full	9.00	8.90	11.96	3.90	3.90	15.86	24.00	Pass
HE160	MCS0	2	047	6185	996/67	6.20	6.50	9.36	3.90	3.90	13.26	24.00	Pass
HE160	MCS0	2	079	6345	Full	8.80	8.90	11.86	3.90	3.90	15.76	24.00	Pass
HE160	MCS0	2	079	6345	996/S67	6.00	6.20	9.11	3.90	3.90	13.01	24.00	Pass



FCC Band VI MIMO													
Mod.	Data Rate	NTX	CH.	Freq. (MHz)	RU Config.	Conducted Power (dBm)			DG (dBi)		EIRP Power (dBm)	EIRP Power Limit (dBm)	Pass /Fail
						Ant 9	Ant 8	SUM	Ant 9	Ant 8	SUM		
HE20	MCS0	2	097	6435	Full	0.70	1.30	4.02	3.90		7.92	24.00	Pass
HE20	MCS0	2	097	6435	26/0	-9.30	-9.10	-6.19	3.90		-2.29	24.00	Pass
HE20	MCS0	2	097	6435	52/37	-6.60	-6.10	-3.33	3.90		0.57	24.00	Pass
HE20	MCS0	2	097	6435	106/53	-3.30	-2.70	0.02	3.90		3.92	24.00	Pass
HE20	MCS0	2	105	6475	Full	1.00	1.50	4.27	3.90		8.17	24.00	Pass
HE20	MCS0	2	105	6475	26/4	-7.80	-7.60	-4.69	3.90		-0.79	24.00	Pass
HE20	MCS0	2	105	6475	52/39	-5.70	-5.40	-2.54	3.90		1.36	24.00	Pass
HE20	MCS0	2	105	6475	106/54	-3.20	-2.80	0.01	3.90		3.91	24.00	Pass
HE20	MCS0	2	113	6515	Full	0.50	1.50	4.04	3.90		7.94	24.00	Pass
HE20	MCS0	2	113	6515	26/8	-9.30	-8.40	-5.82	3.90		-1.92	24.00	Pass
HE20	MCS0	2	113	6515	52/40	-6.70	-5.40	-2.99	3.90		0.91	24.00	Pass
HE20	MCS0	2	113	6515	106/54	-4.00	-2.90	-0.40	3.90		3.50	24.00	Pass
HE40	MCS0	2	099	6445	Full	3.90	3.80	6.86	3.90		10.76	24.00	Pass
HE40	MCS0	2	099	6445	242/61	0.80	1.00	3.91	3.90		7.81	24.00	Pass
HE40	MCS0	2	107	6485	Full	3.90	4.00	6.96	3.90		10.86	24.00	Pass
HE40	MCS0	2	107	6485	242/62	0.40	1.10	3.77	3.90		7.67	24.00	Pass
HE80	MCS0	2	103	6465	Full	6.50	6.70	9.61	3.90		13.51	24.00	Pass
HE80	MCS0	2	103	6465	484/65	3.80	3.80	6.81	3.90		10.71	24.00	Pass



FCC Band VI straddle channel MIMO													
Mod.	Data Rate	NTX	CH.	Freq. (MHz)	RU Config.	Conducted Power (dBm)			DG (dBi)		EIRP Power (dBm)	EIRP Power Limit (dBm)	Pass /Fail
						Ant 9	Ant 8	SUM	Ant 9	Ant 8	SUM		
HE40	MCS0	2	115	6525	Full	4.10	4.10	7.11	3.90		11.01	24.00	Pass
HE40	MCS0	2	115	6525	242/62	1.00	1.30	4.16	3.90		8.06	24.00	Pass
HE80	MCS0	2	119	6545	Full	7.00	7.20	10.11	3.90		14.01	24.00	Pass
HE80	MCS0	2	119	6545	484/66	4.10	4.30	7.21	3.90		11.11	24.00	Pass
HE160	MCS0	2	111	6505	Full	8.30	8.70	11.51	3.90		15.41	24.00	Pass
HE160	MCS0	2	111	6505	996/67	6.30	6.20	9.26	3.90		13.16	24.00	Pass
HE160	MCS0	2	111	6505	996/S67	5.50	5.70	8.61	3.90		12.51	24.00	Pass



FCC Band VII MIMO													
Mod.	Data Rate	NTX	CH.	Freq. (MHz)	RU Config.	Conducted Power (dBm)			DG (dBi)		EIRP Power (dBm)	EIRP Power Limit (dBm)	Pass /Fail
						Ant 9	Ant 8	SUM	Ant 9	Ant 8	SUM		
HE20	MCS0	2	117	6535	Full	1.00	1.20	4.11	3.90		8.01	24.00	Pass
HE20	MCS0	2	117	6535	26/0	-8.80	-8.80	-5.79	3.90		-1.89	24.00	Pass
HE20	MCS0	2	117	6535	52/37	-5.90	-5.90	-2.89	3.90		1.01	24.00	Pass
HE20	MCS0	2	117	6535	106/53	-3.00	-2.70	0.16	3.90		4.06	24.00	Pass
HE20	MCS0	2	149	6695	Full	1.40	0.60	4.03	3.90		7.93	24.00	Pass
HE20	MCS0	2	149	6695	26/4	-7.20	-8.40	-4.75	3.90		-0.85	24.00	Pass
HE20	MCS0	2	149	6695	52/38	-5.20	-6.10	-2.62	3.90		1.28	24.00	Pass
HE20	MCS0	2	149	6695	106/53	-2.20	-3.40	0.25	3.90		4.15	24.00	Pass
HE20	MCS0	2	181	6855	Full	1.10	0.70	3.91	3.90		7.81	24.00	Pass
HE20	MCS0	2	181	6855	26/8	-9.20	-9.40	-6.29	3.90		-2.39	24.00	Pass
HE20	MCS0	2	181	6855	52/40	-6.30	-6.40	-3.34	3.90		0.56	24.00	Pass
HE20	MCS0	2	181	6855	106/54	-2.90	-3.30	-0.09	3.90		3.81	24.00	Pass
HE40	MCS0	2	123	6565	Full	4.40	4.20	7.31	3.90		11.21	24.00	Pass
HE40	MCS0	2	123	6565	242/61	0.90	1.50	4.22	3.90		8.12	24.00	Pass
HE40	MCS0	2	147	6685	Full	4.20	3.80	7.01	3.90		10.91	24.00	Pass
HE40	MCS0	2	147	6685	242/61	1.30	0.60	3.97	3.90		7.87	24.00	Pass
HE40	MCS0	2	179	6845	Full	4.60	4.00	7.32	3.90		11.22	24.00	Pass
HE40	MCS0	2	179	6845	242/62	1.70	0.50	4.15	3.90		8.05	24.00	Pass
HE80	MCS0	2	135	6625	Full	7.10	6.50	9.82	3.90		13.72	24.00	Pass
HE80	MCS0	2	135	6625	484/65	3.90	3.40	6.67	3.90		10.57	24.00	Pass
HE80	MCS0	2	151	6705	Full	6.90	6.80	9.86	3.90		13.76	24.00	Pass
HE80	MCS0	2	151	6705	484/65	3.80	3.30	6.57	3.90		10.47	24.00	Pass
HE80	MCS0	2	167	6785	Full	7.20	6.70	9.97	3.90		13.87	24.00	Pass
HE80	MCS0	2	167	6785	484/66	3.90	3.40	6.67	3.90		10.57	24.00	Pass
HE160	MCS0	2	143	6665	Full	8.60	8.50	11.56	3.90		15.46	24.00	Pass
HE160	MCS0	2	143	6665	996/67	5.70	5.50	8.61	3.90		12.51	24.00	Pass



Band VIII MIMO													
Mod.	Data Rate	NTX	CH.	Freq. (MHz)	RU Config.	Conducted Power (dBm)			DG (dBi)		EIRP Power (dBm)	EIRP Power Limit (dBm)	Pass /Fail
						Ant 9	Ant 8	SUM	Ant 9	Ant 8	SUM		
HE20	MCS0	2	189	6895	Full	0.80	0.40	3.61	4.00		7.61	24.00	Pass
HE20	MCS0	2	189	6895	26/0	-9.30	-9.70	-6.49	4.00		-2.49	24.00	Pass
HE20	MCS0	2	189	6895	52/37	-6.40	-6.60	-3.49	4.00		0.51	24.00	Pass
HE20	MCS0	2	189	6895	106/53	-3.40	-3.50	-0.44	4.00		3.56	24.00	Pass
HE20	MCS0	2	209	6995	Full	0.40	0.70	3.56	4.00		7.56	24.00	Pass
HE20	MCS0	2	209	6995	26/4	-8.80	-8.30	-5.53	4.00		-1.53	24.00	Pass
HE20	MCS0	2	209	6995	52/38	-6.90	-6.10	-3.47	4.00		0.53	24.00	Pass
HE20	MCS0	2	209	6995	106/53	-3.80	-3.30	-0.53	4.00		3.47	24.00	Pass
HE20	MCS0	2	229	7095	Full	0.70	1.10	3.91	4.00		7.91	24.00	Pass
HE20	MCS0	2	229	7095	26/8	-8.70	-8.20	-5.43	4.00		-1.43	24.00	Pass
HE20	MCS0	2	229	7095	52/40	-5.80	-5.20	-2.48	4.00		1.52	24.00	Pass
HE20	MCS0	2	229	7095	106/54	-3.60	-3.10	-0.33	4.00		3.67	24.00	Pass
HE20	MCS0	2	233	7115	Full	-8.20	-8.70	-5.43	4.00		-1.43	24.00	Pass
HE20	MCS0	2	233	7115	26/8	-18.20	-19.00	-15.57	4.00		-11.57	24.00	Pass
HE20	MCS0	2	233	7115	52/40	-14.50	-16.00	-12.18	4.00		-8.18	24.00	Pass
HE20	MCS0	2	233	7115	106/54	-11.50	-13.00	-9.18	4.00		-5.18	24.00	Pass
HE40	MCS0	2	195	6925	Full	3.50	3.70	6.61	4.00		10.61	24.00	Pass
HE40	MCS0	2	195	6925	242/61	0.60	0.00	3.32	4.00		7.32	24.00	Pass
HE40	MCS0	2	211	7005	Full	3.90	3.90	6.91	4.00		10.91	24.00	Pass
HE40	MCS0	2	211	7005	242/62	0.60	0.30	3.46	4.00		7.46	24.00	Pass
HE40	MCS0	2	227	7085	Full	4.20	4.50	7.36	4.00		11.36	24.00	Pass
HE40	MCS0	2	227	7085	242/62	1.20	1.40	4.31	4.00		8.31	24.00	Pass
HE80	MCS0	2	199	6945	Full	6.60	6.70	9.66	4.00		13.66	24.00	Pass
HE80	MCS0	2	199	6945	484/65	3.40	3.50	6.46	4.00		10.46	24.00	Pass
HE80	MCS0	2	215	7025	Full	6.20	6.60	9.41	4.00		13.41	24.00	Pass
HE80	MCS0	2	215	7025	484/66	3.40	3.50	6.46	4.00		10.46	24.00	Pass



Band VIII MIMO													
Mod.	Data Rate	NTX	CH.	Freq. (MHz)	RU Config.	Conducted Power (dBm)			DG (dBi)		EIRP Power (dBm)	EIRP Power Limit (dBm)	Pass /Fail
						Ant 9	Ant 8	SUM	Ant 9	Ant 8	SUM		
HE160	MCS0	2	207	6985	Full	8.10	8.10	11.11	4.00		15.11	24.00	Pass
HE160	MCS0	2	207	6985	996/67	5.40	5.60	8.51	4.00		12.51	24.00	Pass
HE160	MCS0	2	207	6985	996/S67	5.00	4.60	7.81	4.00		11.81	24.00	Pass

FCC Band VIII straddle channel MIMO													
Mod.	Data Rate	NTX	CH.	Freq. (MHz)	RU Config.	Conducted Power (dBm)			DG (dBi)		EIRP Power (dBm)	EIRP Power Limit (dBm)	Pass /Fail
						Ant 9	Ant 8	SUM	Ant 9	Ant 8	SUM		
HE20	MCS0	2	185	6875	Full	1.30	0.80	4.07	4.00		8.07	24.00	Pass
HE20	MCS0	2	185	6875	26/8	-9.10	-9.40	-6.24	4.00		-2.24	24.00	Pass
HE20	MCS0	2	185	6875	52/40	-6.10	-6.40	-3.24	4.00		0.76	24.00	Pass
HE20	MCS0	2	185	6875	106/54	-2.80	-3.30	-0.03	4.00		3.97	24.00	Pass
HE40	MCS0	2	187	6885	Full	4.10	3.90	7.01	4.00		11.01	24.00	Pass
HE40	MCS0	2	187	6885	242/62	-9.30	-9.70	-6.49	4.00		-2.49	24.00	Pass
HE80	MCS0	2	183	6865	Full	6.80	6.90	9.86	4.00		13.86	24.00	Pass
HE80	MCS0	2	183	6865	484/66	3.50	3.30	6.41	4.00		10.41	24.00	Pass
HE160	MCS0	2	175	6825	Full	8.70	8.30	11.51	4.00		15.51	24.00	Pass
HE160	MCS0	2	175	6825	996/S67	5.70	5.30	8.51	4.00		12.51	24.00	Pass



<CDD Mode>

<Standard Client>

FCC Band V MIMO												
Mod.	Data Rate	NTX	CH.	Freq. (MHz)	Conducted Power (dBm)			DG (dBi)		EIRP Power (dBm)	EIRP Power Limit (dBm)	Pass /Fail
					Ant 9	Ant 8	SUM	Ant 9	Ant 8	SUM		
11a	6Mbps	2	001	5955	12.40	12.40	15.41	3.90		19.31	30.00	Pass
11a	6Mbps	2	049	6195	12.50	11.90	15.22	3.90		19.12	30.00	Pass
11a	6Mbps	2	093	6415	11.70	12.50	15.13	3.90		19.03	30.00	Pass
HT20	MCS0	2	001	5955	9.20	9.00	12.11	3.90		16.01	30.00	Pass
HT20	MCS0	2	049	6195	9.40	8.30	11.90	3.90		15.80	30.00	Pass
HT20	MCS0	2	093	6415	9.10	9.40	12.26	3.90		16.16	30.00	Pass
HT40	MCS0	2	003	5965	9.40	9.20	12.31	3.90		16.21	30.00	Pass
HT40	MCS0	2	051	6205	9.30	8.30	11.84	3.90		15.74	30.00	Pass
HT40	MCS0	2	091	6405	9.10	9.30	12.21	3.90		16.11	30.00	Pass
VHT20	MCS0	2	001	5955	9.20	9.00	12.11	3.90		16.01	30.00	Pass
VHT20	MCS0	2	049	6195	9.40	8.30	11.90	3.90		15.80	30.00	Pass
VHT20	MCS0	2	093	6415	9.10	9.40	12.26	3.90		16.16	30.00	Pass
VHT40	MCS0	2	003	5965	9.40	9.20	12.31	3.90		16.21	30.00	Pass
VHT40	MCS0	2	051	6205	9.30	8.30	11.84	3.90		15.74	30.00	Pass
VHT40	MCS0	2	091	6405	9.10	9.30	12.21	3.90		16.11	30.00	Pass
VHT80	MCS0	2	007	5985	9.30	8.60	11.97	3.90		15.87	30.00	Pass
VHT80	MCS0	2	055	6225	9.40	8.90	12.17	3.90		16.07	30.00	Pass
VHT80	MCS0	2	087	6385	9.30	9.40	12.36	3.90		16.26	30.00	Pass
VHT160	MCS0	2	015	6025	9.30	8.80	12.07	3.90		15.97	30.00	Pass
VHT160	MCS0	2	047	6185	9.30	8.40	11.88	3.90		15.78	30.00	Pass
VHT160	MCS0	2	079	6345	9.10	9.00	12.06	3.90		15.96	30.00	Pass



FCC Band VII MIMO												
Mod.	Data Rate	NTX	CH.	Freq. (MHz)	Conducted Power (dBm)			DG (dBi)		EIRP Power (dBm)	EIRP Power Limit (dBm)	Pass /Fail
					Ant 9	Ant 8	SUM	Ant 9	Ant 8			
11a	6Mbps	2	117	6535	10.60	11.80	14.25	3.90	18.15	30.00	Pass	
11a	6Mbps	2	149	6695	11.20	12.00	14.63	3.90	18.53	30.00	Pass	
11a	6Mbps	2	181	6855	10.40	11.70	14.11	3.90	18.01	30.00	Pass	
HT20	MCS0	2	117	6535	7.90	8.90	11.44	3.90	15.34	30.00	Pass	
HT20	MCS0	2	149	6695	8.60	8.70	11.66	3.90	15.56	30.00	Pass	
HT20	MCS0	2	181	6855	8.80	8.60	11.71	3.90	15.61	30.00	Pass	
HT40	MCS0	2	123	6565	8.30	8.80	11.57	3.90	15.47	30.00	Pass	
HT40	MCS0	2	147	6685	8.60	8.70	11.66	3.90	15.56	30.00	Pass	
HT40	MCS0	2	179	6845	8.70	8.90	11.81	3.90	15.71	30.00	Pass	
VHT20	MCS0	2	117	6535	7.90	8.90	11.44	3.90	15.34	30.00	Pass	
VHT20	MCS0	2	149	6695	8.60	8.70	11.66	3.90	15.56	30.00	Pass	
VHT20	MCS0	2	181	6855	8.80	8.60	11.71	3.90	15.61	30.00	Pass	
VHT40	MCS0	2	123	6565	8.30	8.80	11.57	3.90	15.47	30.00	Pass	
VHT40	MCS0	2	147	6685	8.60	8.70	11.66	3.90	15.56	30.00	Pass	
VHT40	MCS0	2	179	6845	8.70	8.90	11.81	3.90	15.71	30.00	Pass	
VHT80	MCS0	2	135	6625	8.30	8.80	11.57	3.90	15.47	30.00	Pass	
VHT80	MCS0	2	151	6705	8.40	8.60	11.51	3.90	15.41	30.00	Pass	
VHT80	MCS0	2	167	6785	8.90	8.80	11.86	3.90	15.76	30.00	Pass	
VHT160	MCS0	2	143	6665	8.10	8.80	11.47	3.90	15.37	30.00	Pass	
VHT160	MCS0	2	175	6825	8.90	8.70	11.81	3.90	15.71	30.00	Pass	



FCC Band V MIMO													
Mod.	Data Rate	NTX	CH.	Freq. (MHz)	RU Config.	Conducted Power (dBm)			DG (dBi)		EIRP Power (dBm)	EIRP Power Limit (dBm)	Pass /Fail
						Ant 9	Ant 8	SUM	Ant 9	Ant 8			
HE20	MCS0	2	001	5955	Full	9.30	9.10	12.21	3.90		16.11	30.00	Pass
HE20	MCS0	2	049	6195	Full	9.50	8.40	12.00	3.90		15.90	30.00	Pass
HE20	MCS0	2	093	6415	Full	9.20	9.50	12.36	3.90		16.26	30.00	Pass
HE40	MCS0	2	003	5965	Full	9.50	9.30	12.41	3.90		16.31	30.00	Pass
HE40	MCS0	2	051	6205	Full	9.40	8.40	11.94	3.90		15.84	30.00	Pass
HE40	MCS0	2	091	6405	Full	9.20	9.40	12.31	3.90		16.21	30.00	Pass
HE80	MCS0	2	007	5985	Full	9.40	8.70	12.07	3.90		15.97	30.00	Pass
HE80	MCS0	2	055	6225	Full	9.50	9.00	12.27	3.90		16.17	30.00	Pass
HE80	MCS0	2	087	6385	Full	9.40	9.50	12.46	3.90		16.36	30.00	Pass
HE160	MCS0	2	015	6025	Full	9.40	8.90	12.17	3.90		16.07	30.00	Pass
HE160	MCS0	2	047	6185	Full	9.40	8.50	11.98	3.90		15.88	30.00	Pass
HE160	MCS0	2	079	6345	Full	9.20	9.10	12.16	3.90		16.06	30.00	Pass



FCC Band VII MIMO													
Mod.	Data Rate	NTX	CH.	Freq. (MHz)	RU Config.	Conducted Power (dBm)			DG (dBi)		EIRP Power (dBm)	EIRP Power Limit (dBm)	Pass /Fail
						Ant 9	Ant 8	SUM	Ant 9	Ant 8			
HE20	MCS0	2	117	6535	Full	8.00	9.00	11.54	3.90	15.44	30.00	Pass	
HE20	MCS0	2	149	6695	Full	8.70	8.80	11.76	3.90	15.66	30.00	Pass	
HE20	MCS0	2	181	6855	Full	8.90	8.70	11.81	3.90	15.71	30.00	Pass	
HE40	MCS0	2	123	6565	Full	8.40	8.90	11.67	3.90	15.57	30.00	Pass	
HE40	MCS0	2	147	6685	Full	8.70	8.80	11.76	3.90	15.66	30.00	Pass	
HE40	MCS0	2	179	6845	Full	8.80	9.00	11.91	3.90	15.81	30.00	Pass	
HE80	MCS0	2	135	6625	Full	8.40	8.90	11.67	3.90	15.57	30.00	Pass	
HE80	MCS0	2	151	6705	Full	8.50	8.70	11.61	3.90	15.51	30.00	Pass	
HE80	MCS0	2	167	6785	Full	9.00	8.90	11.96	3.90	15.86	30.00	Pass	
HE160	MCS0	2	143	6665	Full	8.20	8.90	11.57	3.90	15.47	30.00	Pass	



<TXBF Mode>

<Indoor Client>

FCC Band V MIMO													
Mod.	Data Rate	NTX	CH.	Freq. (MHz)	RU Config.	Conducted Power (dBm)			DG (dBi)		EIRP Power (dBm)	EIRP Power Limit (dBm)	Pass /Fail
						Ant 9	Ant 8	SUM	Ant 9	Ant 8	SUM		
HE20	MCS3	2	049	6195	Full	0.60	1.20	3.92	6.57		10.49	24.00	Pass
HE20	MCS3	2	093	6415	Full	0.30	1.20	3.78	6.57		10.35	24.00	Pass
HE40	MCS0	2	051	6205	Full	3.50	4.10	6.82	6.57		13.39	24.00	Pass
HE40	MCS0	2	091	6405	Full	3.30	3.90	6.62	6.57		13.19	24.00	Pass
HE80	MCS0	2	055	6225	Full	6.00	7.00	9.54	6.57		16.11	24.00	Pass
HE80	MCS0	2	087	6385	Full	6.10	7.00	9.58	6.57		16.15	24.00	Pass
HE160	MCS0	2	047	6185	Full	8.40	9.40	11.94	6.57		18.51	24.00	Pass
HE160	MCS0	2	079	6345	Full	8.30	9.30	11.84	6.57		18.41	24.00	Pass

FCC Band VI MIMO													
Mod.	Data Rate	NTX	CH.	Freq. (MHz)	RU Config.	Conducted Power (dBm)			DG (dBi)		EIRP Power (dBm)	EIRP Power Limit (dBm)	Pass /Fail
						Ant 9	Ant 8	SUM	Ant 9	Ant 8	SUM		
HE20	MCS0	2	097	6435	Full	0.40	1.40	3.94	6.57		10.51	24.00	Pass
HE20	MCS0	2	105	6475	Full	0.50	1.90	4.27	6.57		10.83	24.00	Pass
HE20	MCS0	2	113	6515	Full	0.20	1.90	4.14	6.57		10.71	24.00	Pass
HE40	MCS0	2	099	6445	Full	3.20	4.20	6.74	6.57		13.31	24.00	Pass
HE40	MCS0	2	107	6485	Full	3.20	4.20	6.74	6.57		13.31	24.00	Pass
HE80	MCS0	2	103	6465	Full	6.10	6.90	9.53	6.57		16.10	24.00	Pass



FCC Band VI straddle channel MIMO													
Mod.	Data Rate	NTX	CH.	Freq. (MHz)	RU Config.	Conducted Power (dBm)			DG (dBi)		EIRP Power (dBm)	EIRP Power Limit (dBm)	Pass /Fail
						Ant 9	Ant 8	SUM	Ant 9	Ant 8			
HE40	MCS0	2	115	6525	Full	3.40	4.10	6.77	6.57		13.34	24.00	Pass
HE80	MCS0	2	119	6545	Full	6.60	7.10	9.87	6.57		16.43	24.00	Pass
HE160	MCS0	2	111	6505	Full	7.80	8.90	11.40	6.57		17.96	24.00	Pass

FCC Band VII MIMO													
Mod.	Data Rate	NTX	CH.	Freq. (MHz)	RU Config.	Conducted Power (dBm)			DG (dBi)		EIRP Power (dBm)	EIRP Power Limit (dBm)	Pass /Fail
						Ant 9	Ant 8	SUM	Ant 9	Ant 8			
HE20	MCS0	2	117	6535	Full	1.00	1.40	4.21	6.57		10.78	24.00	Pass
HE20	MCS0	2	149	6695	Full	1.20	0.60	3.92	6.57		10.49	24.00	Pass
HE20	MCS0	2	181	6855	Full	1.00	0.70	3.86	6.57		10.43	24.00	Pass
HE40	MCS0	2	123	6565	Full	3.80	4.50	7.17	6.57		13.74	24.00	Pass
HE40	MCS0	2	147	6685	Full	3.60	4.30	6.97	6.57		13.54	24.00	Pass
HE40	MCS0	2	179	6845	Full	3.90	4.50	7.22	6.57		13.79	24.00	Pass
HE80	MCS0	2	135	6625	Full	6.40	6.90	9.67	6.57		16.23	24.00	Pass
HE80	MCS0	2	151	6705	Full	6.30	7.10	9.73	6.57		16.30	24.00	Pass
HE80	MCS0	2	167	6785	Full	6.30	7.30	9.84	6.57		16.41	24.00	Pass
HE160	MCS0	2	143	6665	Full	8.10	8.90	11.53	6.57		18.10	24.00	Pass



Band VIII MIMO													
Mod.	Data Rate	NTX	CH.	Freq. (MHz)	RU Config.	Conducted Power (dBm)			DG (dBi)		EIRP Power (dBm)	EIRP Power Limit (dBm)	Pass /Fail
						Ant 9	Ant 8	SUM	Ant 9	Ant 8			
HE20	MCS0	2	189	6895	Full	0.20	0.90	3.57	6.96	10.53	24.00	Pass	
HE20	MCS0	2	209	6995	Full	-0.20	1.20	3.57	6.96	10.53	24.00	Pass	
HE20	MCS0	2	229	7095	Full	0.20	1.70	4.02	6.96	10.99	24.00	Pass	
HE20	MCS0	2	233	7115	Full	-8.90	-8.10	-5.47	6.96	1.49	24.00	Pass	
HE40	MCS0	2	195	6925	Full	2.90	3.50	6.22	6.96	13.18	24.00	Pass	
HE40	MCS0	2	211	7005	Full	3.20	3.90	6.57	6.96	13.53	24.00	Pass	
HE40	MCS0	2	227	7085	Full	3.50	4.50	7.04	6.96	14.00	24.00	Pass	
HE80	MCS0	2	199	6945	Full	5.90	6.90	9.44	6.96	16.40	24.00	Pass	
HE80	MCS0	2	215	7025	Full	5.90	6.60	9.27	6.96	16.23	24.00	Pass	
HE160	MCS0	2	207	6985	Full	7.60	8.40	11.03	6.96	17.99	24.00	Pass	

FCC Band VIII straddle channel MIMO													
Mod.	Data Rate	NTX	CH.	Freq. (MHz)	RU Config.	Conducted Power (dBm)			DG (dBi)		EIRP Power (dBm)	EIRP Power Limit (dBm)	Pass /Fail
						Ant 9	Ant 8	SUM	Ant 9	Ant 8			
HE20	MCS0	2	185	6875	Full	0.70	0.80	3.76	6.96	10.72	24.00	Pass	
HE40	MCS0	2	187	6885	Full	3.40	4.10	6.77	6.96	13.73	24.00	Pass	
HE80	MCS0	2	183	6865	Full	6.20	7.20	9.74	6.96	16.70	24.00	Pass	
HE160	MCS0	2	175	6825	Full	8.20	8.70	11.47	6.96	18.43	24.00	Pass	



<TXBF Mode>

<Standard Client>

FCC Band V MIMO													
Mod.	Data Rate	NTX	CH.	Freq. (MHz)	RU Config.	Conducted Power (dBm)			DG (dBi)		EIRP Power (dBm)	EIRP Power Limit (dBm)	Pass /Fail
						Ant 9	Ant 8	SUM	Ant 9	Ant 8	SUM		
HE20	MCS3	2	049	6195	Full	8.60	9.50	12.08	6.57		18.65	30.00	Pass
HE20	MCS3	2	093	6415	Full	8.60	9.50	12.08	6.57		18.65	30.00	Pass
HE40	MCS0	2	051	6205	Full	8.90	8.90	11.91	6.57		18.48	30.00	Pass
HE40	MCS0	2	091	6405	Full	8.70	9.70	12.24	6.57		18.81	30.00	Pass
HE80	MCS0	2	055	6225	Full	9.20	9.20	12.21	6.57		18.78	30.00	Pass
HE80	MCS0	2	087	6385	Full	9.10	9.50	12.31	6.57		18.88	30.00	Pass
HE160	MCS0	2	047	6185	Full	8.40	9.30	11.88	6.57		18.45	30.00	Pass
HE160	MCS0	2	079	6345	Full	8.60	9.60	12.14	6.57		18.71	30.00	Pass

FCC Band VII MIMO													
Mod.	Data Rate	NTX	CH.	Freq. (MHz)	RU Config.	Conducted Power (dBm)			DG (dBi)		EIRP Power (dBm)	EIRP Power Limit (dBm)	Pass /Fail
						Ant 9	Ant 8	SUM	Ant 9	Ant 8	SUM		
HE20	MCS0	2	117	6535	Full	7.70	8.70	11.24	6.57		17.81	30.00	Pass
HE20	MCS0	2	149	6695	Full	8.20	9.20	11.74	6.57		18.31	30.00	Pass
HE20	MCS0	2	181	6855	Full	8.40	9.10	11.77	6.57		18.34	30.00	Pass
HE40	MCS0	2	123	6565	Full	7.80	9.30	11.62	6.57		18.19	30.00	Pass
HE40	MCS0	2	147	6685	Full	8.10	9.30	11.75	6.57		18.32	30.00	Pass
HE40	MCS0	2	179	6845	Full	8.20	9.20	11.74	6.57		18.31	30.00	Pass
HE80	MCS0	2	135	6625	Full	8.10	9.10	11.64	6.57		18.21	30.00	Pass
HE80	MCS0	2	151	6705	Full	8.00	9.00	11.54	6.57		18.11	30.00	Pass
HE80	MCS0	2	167	6785	Full	8.50	9.30	11.93	6.57		18.50	30.00	Pass
HE160	MCS0	2	143	6665	Full	7.70	8.90	11.35	6.57		17.92	30.00	Pass



3.3 Fundamental Power Spectral Density Measurement

3.3.1 Limit of Fundamental Power Spectral Density

<FCC 14-30 CFR 15.407>

(a)(8) For client devices operating under the control of an indoor access point in the 5.925-7.125 GHz bands, the maximum power spectral density must not exceed -1 dBm e.i.r.p. in any 1-megahertz band.

(a)(7) For client devices, except for fixed client devices as defined in this subpart, operating under the control of a standard power access point in 5.925-6.425 GHz and 6.525-6.875 GHz bands, the maximum power spectral density must not exceed 17 dBm e.i.r.p. in any 1-megahertz band,

3.3.2 Measuring Instruments

Please refer to the measuring equipment list in this test report.



3.3.3 Test Procedures

The testing follows FCC KDB 789033 D02 General UNII Test Procedures New Rules v02r01.

Section F) Maximum power spectral density.

<CDD and SDM Modes>

Method SA-2

(trace averaging across on and off times of the EUT transmissions, followed by duty cycle correction).

- Measure the duty cycle.
- Set span to encompass the entire emission bandwidth (EBW) of the signal.
- Set RBW = 1 MHz.
- Set VBW \geq 3 MHz.
- Number of points in sweep \geq 2 Span / RBW.
- Sweep time = auto.
- Detector = RMS
- Trace average at least 100 traces in power averaging mode.
- Add $10 \log(1/x)$, where x is the duty cycle, to the measured power in order to compute the average power during the actual transmission times. For example, add $10 \log(1/0.25) = 6$ dB if the duty cycle is 25 percent.

<TXBF Modes>

Method SA-3

(power averaging (rms) detection with max hold):

- Set span to encompass the entire emission bandwidth (EBW) of the signal.
- Set RBW = 1 MHz.
- Set VBW \geq 3 MHz.
- Number of points in sweep \geq 2 Span / RBW.
- Sweep time \leq (number of points in sweep) \times T, when duty cycle is less than 98 percent where T is the minimum transmission duration over which the transmitter is on and is transmitting at its maximum power control level for the tested mode of operation.
- Detector = power averaging (rms).
- Trace mode = max hold.
- Allow max hold to run for at least 60 seconds, or longer as needed to allow the trace to stabilize.

1. The RF output of EUT was connected to the spectrum analyzer by a low loss cable.
2. Each plot has already offset with cable loss, and attenuator loss. Measure the PPSD and record it.
3. For MIMO mode, calculation method follows FCC KDB 662911 D01 Multiple Transmitter Output v02r01.

Method (a): Measure and sum the spectra across the outputs.

The total final Power Spectral Density is from a device with 2 transmitter outputs. The spectrum measurements of the individual outputs are all performed with the same span and number of points; the spectrum value in the first spectral bin of output 1 is summed with that in the first spectral bin of output 2 to obtain the value for the first frequency bin of the summed spectrum.

3.3.4 Test Setup

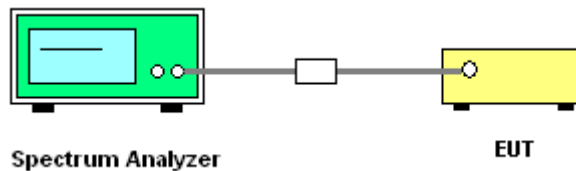



3.3.5 Test Result of Power Spectral Density

Test Engineer :	Jacob Yu, Hank Hsu and Junyu Zhou	Temperature :	17.7~22.5°C
		Relative Humidity :	45.1~61.9%

<SDM Mode>

<Indoor Client>

FCC Band V MIMO_SDM Mode															
Mod.	Data Rate	NTX	CH.	Freq. (MHz)	RU Config.	Duty Factor (dB)		Conducted Power Density with Duty Factor (dBm/MHz)			DG (dBi)		EIRP Power Density (dBm/MHz)	EIRP Power Density Limit (dBm)	Pass /Fail
						Ant 9	Ant 8	Ant 9	Ant 8	SUM	Ant 9	Ant 8	SUM		
HE20	MCS0	2	001	5955	Full	0.00	0.00			-4.60	3.56	-1.04	-1.00	Pass	
HE20	MCS0	2	001	5955	26/0	0.00	0.00			-4.90	3.56	-1.34	-1.00	Pass	
HE20	MCS0	2	001	5955	52/37	0.00	0.00			-4.99	3.56	-1.43	-1.00	Pass	
HE20	MCS0	2	001	5955	106/53	0.00	0.00			-4.95	3.56	-1.39	-1.00	Pass	
HE20	MCS0	2	049	6195	Full	0.00	0.00			-4.57	3.56	-1.01	-1.00	Pass	
HE20	MCS0	2	049	6195	26/4	0.00	0.00			-4.98	3.56	-1.42	-1.00	Pass	
HE20	MCS0	2	049	6195	52/39	0.00	0.00			-4.78	3.56	-1.22	-1.00	Pass	
HE20	MCS0	2	049	6195	106/53	0.00	0.00			-4.58	3.56	-1.02	-1.00	Pass	
HE20	MCS0	2	093	6415	Full	0.00	0.00			-4.88	3.56	-1.32	-1.00	Pass	
HE20	MCS0	2	093	6415	26/8	0.00	0.00			-5.10	3.56	-1.54	-1.00	Pass	
HE20	MCS0	2	093	6415	52/40	0.00	0.00			-5.16	3.56	-1.60	-1.00	Pass	
HE20	MCS0	2	093	6415	106/54	0.00	0.00			-5.19	3.56	-1.63	-1.00	Pass	
HE40	MCS0	2	003	5965	Full	0.00	0.00			-4.67	3.56	-1.11	-1.00	Pass	
HE40	MCS0	2	003	5965	242/61	0.00	0.00			-6.31	3.56	-2.75	-1.00	Pass	
HE40	MCS0	2	051	6205	Full	0.00	0.00			-4.60	3.56	-1.04	-1.00	Pass	
HE40	MCS0	2	051	6205	242/61	0.00	0.00			-4.96	3.56	-1.40	-1.00	Pass	
HE40	MCS0	2	091	6405	Full	0.00	0.00			-4.85	3.56	-1.29	-1.00	Pass	
HE40	MCS0	2	091	6405	242/62	0.00	0.00			-5.17	3.56	-1.61	-1.00	Pass	



FCC Band V MIMO_SDM Mode															
Mod.	Data Rate	NTX	CH.	Freq. (MHz)	RU Config.	Duty Factor (dB)		Conducted Power Density with Duty Factor (dBm/MHz)			DG (dBi)		EIRP Power Density (dBm/MHz)	EIRP Power Density Limit (dBm)	Pass /Fail
						Ant 9	Ant 8	Ant 9	Ant 8	SUM	Ant 9	Ant 8	SUM		
HE80	MCS0	2	007	5985	Full	0.00	0.00	-	-4.68	3.56	-1.12	-1.00	Pass		
HE80	MCS0	2	007	5985	484/65	0.00	0.00	-	-4.79	3.56	-1.23	-1.00	Pass		
HE80	MCS0	2	055	6225	Full	0.00	0.00	-	-4.66	3.56	-1.10	-1.00	Pass		
HE80	MCS0	2	055	6225	484/65	0.00	0.00	-	-4.85	3.56	-1.29	-1.00	Pass		
HE80	MCS0	2	087	6385	Full	0.00	0.00	-	-4.73	3.56	-1.17	-1.00	Pass		
HE80	MCS0	2	087	6385	484/66	0.00	0.00	-	-5.21	3.56	-1.65	-1.00	Pass		
HE160	MCS0	2	015	6025	Full	0.00	0.00	-	-5.40	3.56	-1.84	-1.00	Pass		
HE160	MCS0	2	015	6025	996/67	0.00	0.00	-	-5.80	3.56	-2.24	-1.00	Pass		
HE160	MCS0	2	047	6185	Full	0.00	0.00	-	-5.77	3.56	-2.21	-1.00	Pass		
HE160	MCS0	2	047	6185	996/67	0.00	0.00	-	-6.00	3.56	-2.44	-1.00	Pass		
HE160	MCS0	2	079	6345	Full	0.00	0.00	-	-5.81	3.56	-2.25	-1.00	Pass		
HE160	MCS0	2	079	6345	996/S67	0.00	0.00	-	-5.83	3.56	-2.27	-1.00	Pass		



Band VI MIMO_SDM Mode															
Mod.	Data Rate	NTX	CH.	Freq. (MHz)	RU Config.	Duty Factor (dB)		Conducted Power Density with Duty Factor (dBm/MHz)			DG (dBi)		EIRP Power Density (dBm/MHz)	EIRP Power Density Limit (dBm)	Pass /Fail
						Ant 9	Ant 8	Ant 9	Ant 8	SUM	Ant 9	Ant 8	SUM		
HE20	MCS0	2	097	6435	Full	0.00	0.00			-4.66	3.56	-1.10	-1.00	Pass	
HE20	MCS0	2	097	6435	26/0	0.00	0.00			-4.68	3.56	-1.12	-1.00	Pass	
HE20	MCS0	2	097	6435	52/37	0.00	0.00			-4.81	3.56	-1.25	-1.00	Pass	
HE20	MCS0	2	097	6435	106/53	0.00	0.00			-4.82	3.56	-1.26	-1.00	Pass	
HE20	MCS0	2	105	6475	Full	0.00	0.00			-4.96	3.56	-1.40	-1.00	Pass	
HE20	MCS0	2	105	6475	26/4	0.00	0.00			-5.41	3.56	-1.85	-1.00	Pass	
HE20	MCS0	2	105	6475	52/39	0.00	0.00			-5.03	3.56	-1.47	-1.00	Pass	
HE20	MCS0	2	105	6475	106/54	0.00	0.00			-5.27	3.56	-1.71	-1.00	Pass	
HE20	MCS0	2	113	6515	Full	0.00	0.00			-4.69	3.56	-1.13	-1.00	Pass	
HE20	MCS0	2	113	6515	26/8	0.00	0.00			-5.01	3.56	-1.45	-1.00	Pass	
HE20	MCS0	2	113	6515	52/40	0.00	0.00			-4.74	3.56	-1.18	-1.00	Pass	
HE20	MCS0	2	113	6515	106/54	0.00	0.00			-4.75	3.56	-1.19	-1.00	Pass	
HE40	MCS0	2	099	6445	Full	0.00	0.00			-4.60	3.56	-1.04	-1.00	Pass	
HE40	MCS0	2	099	6445	242/61	0.00	0.00			-4.75	3.56	-1.19	-1.00	Pass	
HE40	MCS0	2	107	6485	Full	0.00	0.00			-4.68	3.56	-1.12	-1.00	Pass	
HE40	MCS0	2	107	6485	242/62	0.00	0.00			-4.71	3.56	-1.15	-1.00	Pass	
HE80	MCS0	2	103	6465	Full	0.00	0.00			-4.81	3.56	-1.25	-1.00	Pass	
HE80	MCS0	2	103	6465	484/65	0.00	0.00			-4.89	3.56	-1.33	-1.00	Pass	



FCC Band VI straddle channel MIMO_SDM Mode															
Mod.	Data Rate	NTX	CH.	Freq. (MHz)	RU Config.	Duty Factor (dB)		Conducted Power Density with Duty Factor (dBm/MHz)			DG (dBi)		EIRP Power Density (dBm/MHz)	EIRP Power Density Limit (dBm)	Pass /Fail
						Ant 9	Ant 8	Ant 9	Ant 8	SUM	Ant 9	Ant 8	SUM		
HE40	MCS0	2	115	6525	Full	0.00	0.00	-		-4.67	3.56	-1.11	-1.00	Pass	
HE40	MCS0	2	115	6525	242/62	0.00	0.00			-4.82	3.56	-1.26	-1.00	Pass	
HE80	MCS0	2	119	6545	Full	0.00	0.00			-4.99	3.56	-1.43	-1.00	Pass	
HE80	MCS0	2	119	6545	484/66	0.00	0.00			-5.06	3.56	-1.50	-1.00	Pass	
HE160	MCS0	2	111	6505	Full	0.00	0.00			-5.99	3.56	-2.43	-1.00	Pass	
HE160	MCS0	2	111	6505	996/67	0.00	0.00			-6.00	3.56	-2.44	-1.00	Pass	
HE160	MCS0	2	111	6505	996/S67	0.00	0.00			-6.20	3.56	-2.64	-1.00	Pass	



FCC Band VII MIMO_SDM Mode															
Mod.	Data Rate	NTX	CH.	Freq. (MHz)	RU Config.	Duty Factor (dB)		Conducted Power Density with Duty Factor (dBm/MHz)			DG (dBi)		EIRP Power Density (dBm/MHz)	EIRP Power Density Limit (dBm)	Pass /Fail
						Ant 9	Ant 8	Ant 9	Ant 8	SUM	Ant 9	Ant 8	SUM		
HE20	MCS0	2	117	6535	Full	0.00	0.00			-5.02	3.56	-1.46	-1.00	Pass	
HE20	MCS0	2	117	6535	26/0	0.00	0.00			-5.21	3.56	-1.65	-1.00	Pass	
HE20	MCS0	2	117	6535	52/37	0.00	0.00			-5.13	3.56	-1.57	-1.00	Pass	
HE20	MCS0	2	117	6535	106/53	0.00	0.00			-5.04	3.56	-1.48	-1.00	Pass	
HE20	MCS0	2	149	6695	Full	0.00	0.00			-4.97	3.56	-1.41	-1.00	Pass	
HE20	MCS0	2	149	6695	26/4	0.00	0.00			-5.31	3.56	-1.75	-1.00	Pass	
HE20	MCS0	2	149	6695	52/38	0.00	0.00			-5.16	3.56	-1.60	-1.00	Pass	
HE20	MCS0	2	149	6695	106/53	0.00	0.00			-5.26	3.56	-1.70	-1.00	Pass	
HE20	MCS0	2	181	6855	Full	0.00	0.00			-4.82	3.56	-1.26	-1.00	Pass	
HE20	MCS0	2	181	6855	26/8	0.00	0.00			-4.89	3.56	-1.33	-1.00	Pass	
HE20	MCS0	2	181	6855	52/40	0.00	0.00			-4.87	3.56	-1.31	-1.00	Pass	
HE20	MCS0	2	181	6855	106/54	0.00	0.00			-5.37	3.56	-1.81	-1.00	Pass	
HE40	MCS0	2	123	6565	Full	0.00	0.00			-4.96	3.56	-1.40	-1.00	Pass	
HE40	MCS0	2	123	6565	242/61	0.00	0.00			-5.05	3.56	-1.49	-1.00	Pass	
HE40	MCS0	2	147	6685	Full	0.00	0.00			-4.87	3.56	-1.31	-1.00	Pass	
HE40	MCS0	2	147	6685	242/61	0.00	0.00			-4.91	3.56	-1.35	-1.00	Pass	
HE40	MCS0	2	179	6845	Full	0.00	0.00			-4.86	3.56	-1.30	-1.00	Pass	
HE40	MCS0	2	179	6845	242/62	0.00	0.00			-5.06	3.56	-1.50	-1.00	Pass	
HE80	MCS0	2	135	6625	Full	0.00	0.00			-5.05	3.56	-1.49	-1.00	Pass	
HE80	MCS0	2	135	6625	484/65	0.00	0.00			-5.14	3.56	-1.58	-1.00	Pass	
HE80	MCS0	2	151	6705	Full	0.00	0.00			-5.03	3.56	-1.47	-1.00	Pass	
HE80	MCS0	2	151	6705	484/65	0.00	0.00			-5.35	3.56	-1.79	-1.00	Pass	
HE80	MCS0	2	167	6785	Full	0.00	0.00			-4.91	3.56	-1.35	-1.00	Pass	
HE80	MCS0	2	167	6785	484/66	0.00	0.00			-5.46	3.56	-1.90	-1.00	Pass	
HE160	MCS0	2	143	6665	Full	0.00	0.00			-6.34	3.56	-2.78	-1.00	Pass	
HE160	MCS0	2	143	6665	996/67	0.00	0.00			-6.51	3.56	-2.95	-1.00	Pass	



FCC Band VIII MIMO_SDM Mode															
Mod.	Data Rate	NTX	CH.	Freq. (MHz)	RU Config.	Duty Factor (dB)		Conducted Power Density with Duty Factor (dBm/MHz)			DG (dBi)		EIRP Power Density (dBm/MHz)	EIRP Power Density Limit (dBm)	Pass /Fail
						Ant 9	Ant 8	Ant 9	Ant 8	SUM	Ant 9	Ant 8	SUM		
HE20	MCS0	2	189	6895	Full	0.00	0.00	-5.32	3.95	-1.37	-1.00	Pass			
HE20	MCS0	2	189	6895	26/0	0.00	0.00	-5.36	3.95	-1.41	-1.00	Pass			
HE20	MCS0	2	189	6895	52/37	0.00	0.00	-5.78	3.95	-1.83	-1.00	Pass			
HE20	MCS0	2	189	6895	106/53	0.00	0.00	-5.69	3.95	-1.74	-1.00	Pass			
HE20	MCS0	2	209	6995	Full	0.00	0.00	-5.17	3.95	-1.22	-1.00	Pass			
HE20	MCS0	2	209	6995	26/4	0.00	0.00	-5.32	3.95	-1.37	-1.00	Pass			
HE20	MCS0	2	209	6995	52/38	0.00	0.00	-5.25	3.95	-1.30	-1.00	Pass			
HE20	MCS0	2	209	6995	106/53	0.00	0.00	-5.44	3.95	-1.49	-1.00	Pass			
HE20	MCS0	2	229	7095	Full	0.00	0.00	-5.16	3.95	-1.21	-1.00	Pass			
HE20	MCS0	2	229	7095	26/8	0.00	0.00	-5.55	3.95	-1.60	-1.00	Pass			
HE20	MCS0	2	229	7095	52/40	0.00	0.00	-5.48	3.95	-1.53	-1.00	Pass			
HE20	MCS0	2	229	7095	106/54	0.00	0.00	-5.40	3.95	-1.45	-1.00	Pass			
HE20	MCS0	2	233	7115	Full	0.00	0.00	-14.02	3.95	-10.07	-1.00	Pass			
HE20	MCS0	2	233	7115	26/8	0.00	0.00	-14.13	3.95	-10.18	-1.00	Pass			
HE20	MCS0	2	233	7115	52/40	0.00	0.00	-14.17	3.95	-10.22	-1.00	Pass			
HE20	MCS0	2	233	7115	106/54	0.00	0.00	-14.04	3.95	-10.09	-1.00	Pass			
HE40	MCS0	2	195	6925	Full	0.00	0.00	-4.98	3.95	-1.03	-1.00	Pass			
HE40	MCS0	2	195	6925	242/61	0.00	0.00	-5.13	3.95	-1.18	-1.00	Pass			
HE40	MCS0	2	211	7005	Full	0.00	0.00	-4.97	3.95	-1.02	-1.00	Pass			
HE40	MCS0	2	211	7005	242/62	0.00	0.00	-5.46	3.95	-1.51	-1.00	Pass			
HE40	MCS0	2	227	7085	Full	0.00	0.00	-5.12	3.95	-1.17	-1.00	Pass			
HE40	MCS0	2	227	7085	242/62	0.00	0.00	-5.59	3.95	-1.64	-1.00	Pass			
HE80	MCS0	2	199	6945	Full	0.00	0.00	-5.09	3.95	-1.14	-1.00	Pass			
HE80	MCS0	2	199	6945	484/65	0.00	0.00	-5.47	3.95	-1.52	-1.00	Pass			
HE80	MCS0	2	215	7025	Full	0.00	0.00	-5.12	3.95	-1.17	-1.00	Pass			
HE80	MCS0	2	215	7025	484/66	0.00	0.00	-5.48	3.95	-1.53	-1.00	Pass			
HE160	MCS0	2	207	6985	Full	0.00	0.00	-6.57	3.95	-2.62	-1.00	Pass			
HE160	MCS0	2	207	6985	996/67	0.00	0.00	-6.65	3.95	-2.70	-1.00	Pass			
HE160	MCS0	2	207	6985	996/S67	0.00	0.00	-6.71	3.95	-2.76	-1.00	Pass			



FCC Band VIII straddle channel MIMO_SDM Mode															
Mod.	Data Rate	NTX	CH.	Freq. (MHz)	RU Config.	Duty Factor (dB)		Conducted Power Density with Duty Factor (dBm/MHz)			DG (dBi)		EIRP Power Density (dBm/MHz)	EIRP Power Density Limit (dBm)	Pass /Fail
						Ant 9	Ant 8	Ant 9	Ant 8	SUM	Ant 9	Ant 8	SUM		
HE20	MCS0	2	185	6875	Full	0.00	0.00	-5.20	3.95	-1.25	-1.00	Pass			
HE20	MCS0	2	185	6875	26/8	0.00	0.00	-5.30	3.95	-1.35	-1.00	Pass			
HE20	MCS0	2	185	6875	52/40	0.00	0.00	-5.36	3.95	-1.41	-1.00	Pass			
HE20	MCS0	2	185	6875	106/54	0.00	0.00	-5.35	3.95	-1.40	-1.00	Pass			
HE40	MCS0	2	187	6885	Full	0.00	0.00	-5.15	3.95	-1.20	-1.00	Pass			
HE40	MCS0	2	187	6885	242/62	0.00	0.00	-5.43	3.95	-1.48	-1.00	Pass			
HE80	MCS0	2	183	6865	Full	0.00	0.00	-5.34	3.95	-1.39	-1.00	Pass			
HE80	MCS0	2	183	6865	484/66	0.00	0.00	-5.60	3.95	-1.65	-1.00	Pass			
HE160	MCS0	2	175	6825	Full	0.00	0.00	-6.34	3.95	-2.39	-1.00	Pass			
HE160	MCS0	2	175	6825	996/S67	0.00	0.00	-6.52	3.95	-2.57	-1.00	Pass			



<802.11ax HE20 Mode>

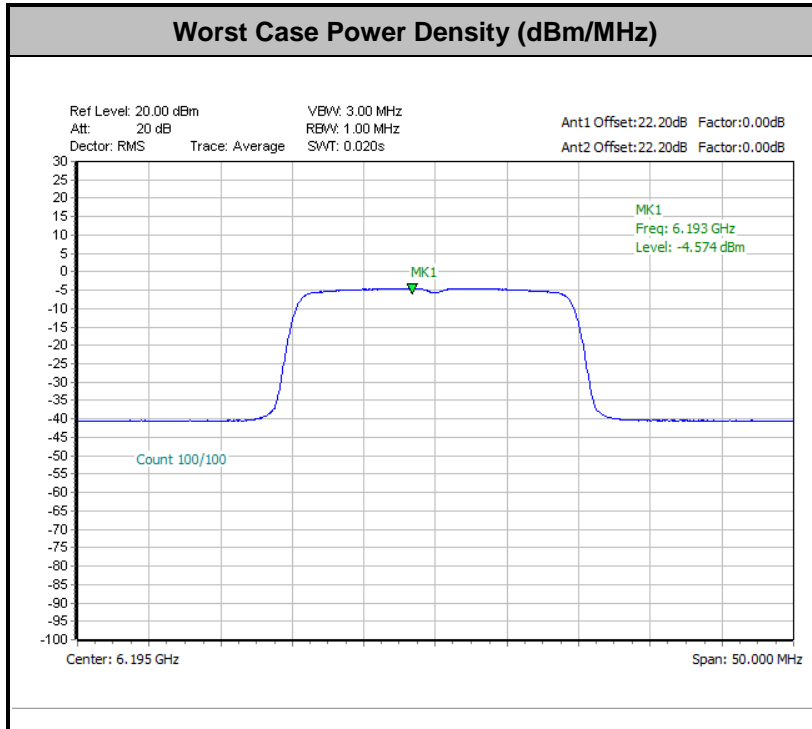

Remark: The test plot is showing a bin by bin combined result mathematically adds two traces.

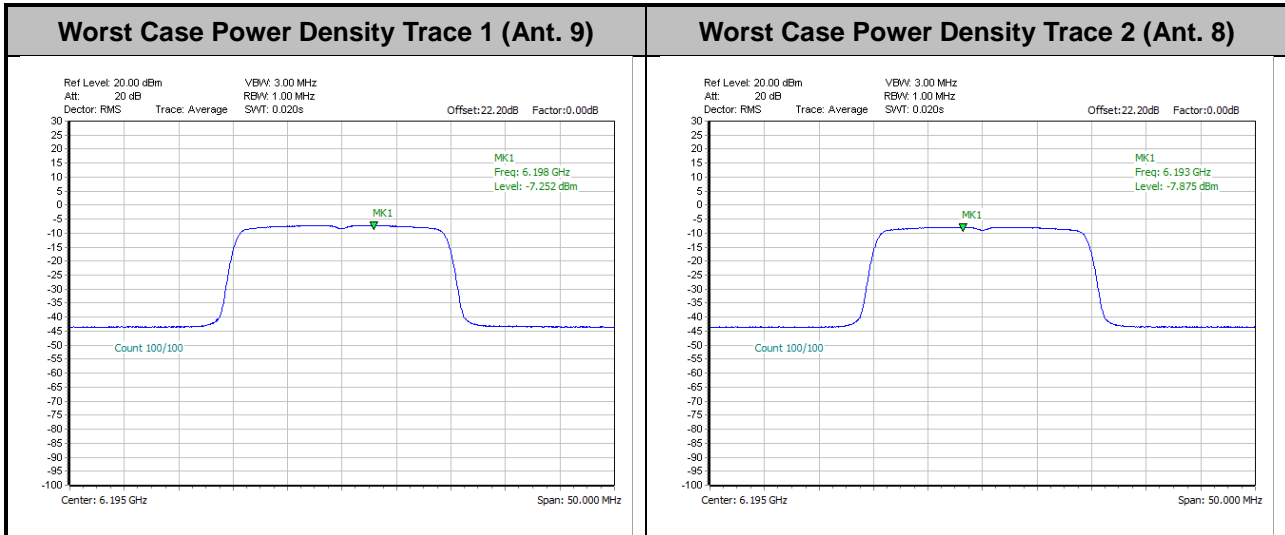



<802.11ax HE40 Mode>

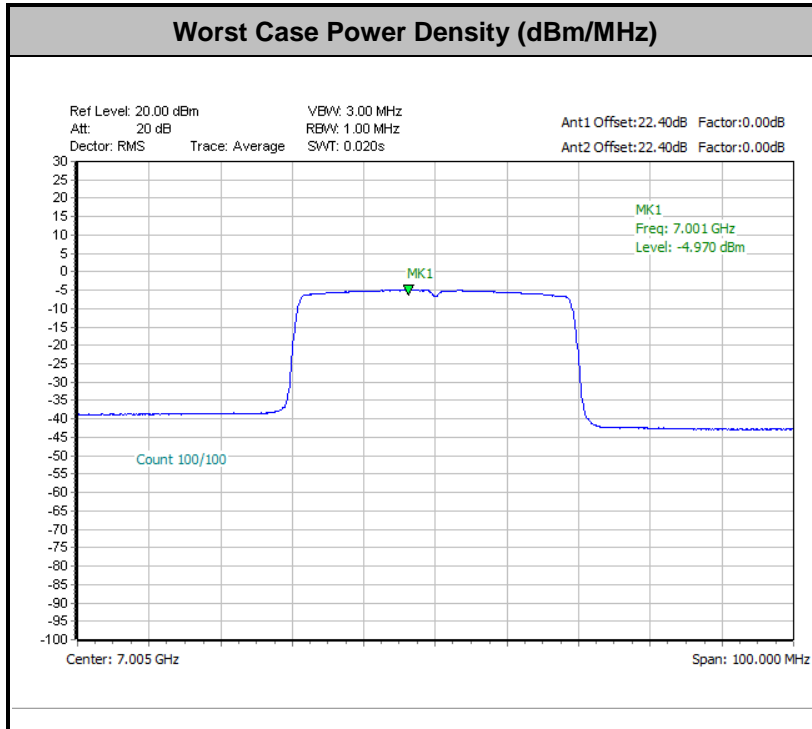

Remark: The test plot is showing a bin by bin combined result mathematically adds two traces.

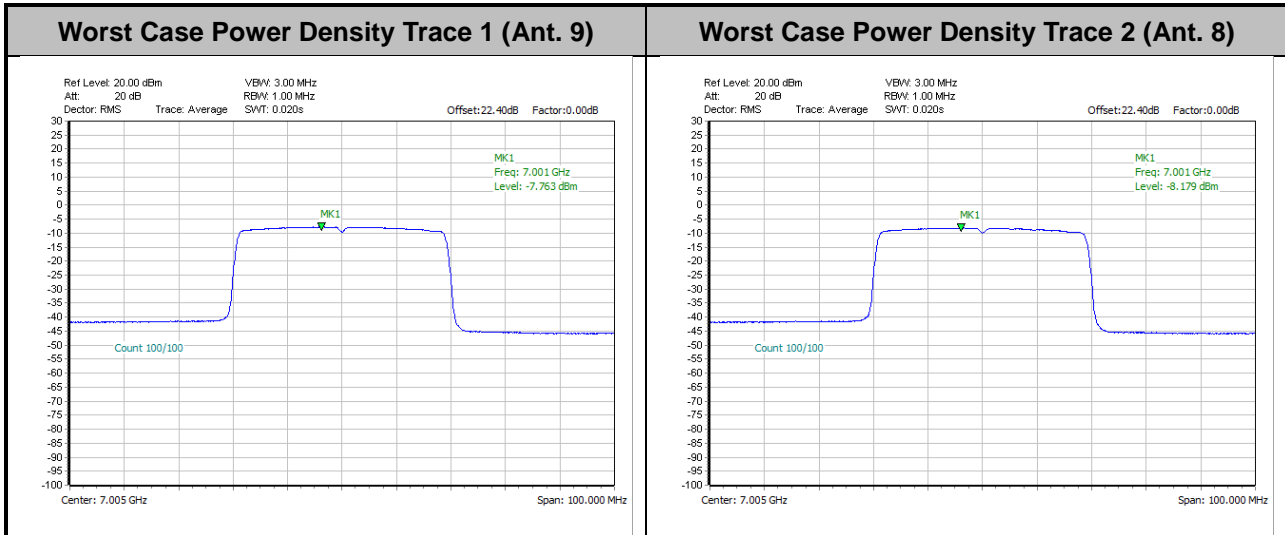



<802.11ax HE80 Mode>

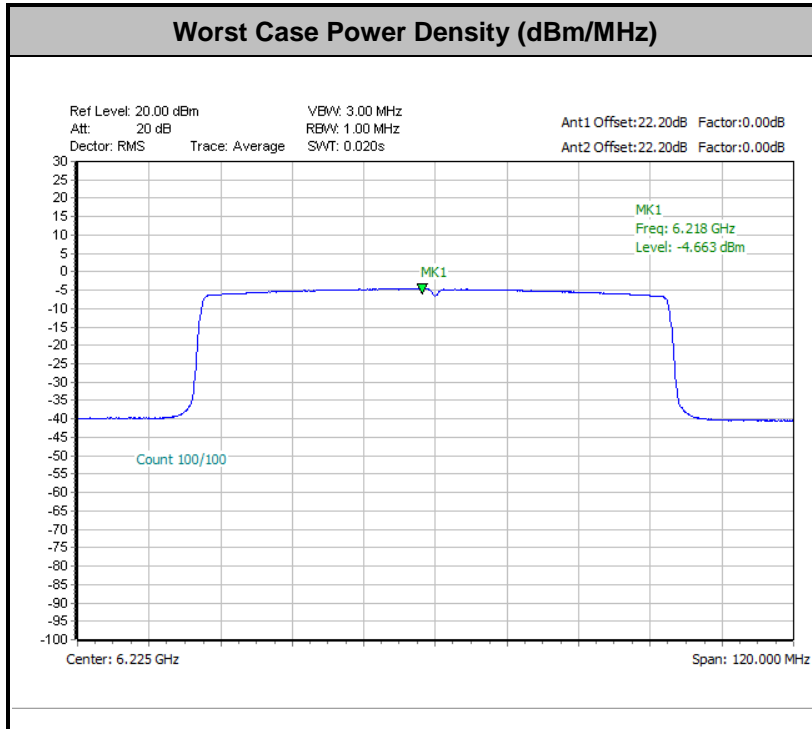

Remark: The test plot is showing a bin by bin combined result mathematically adds two traces.

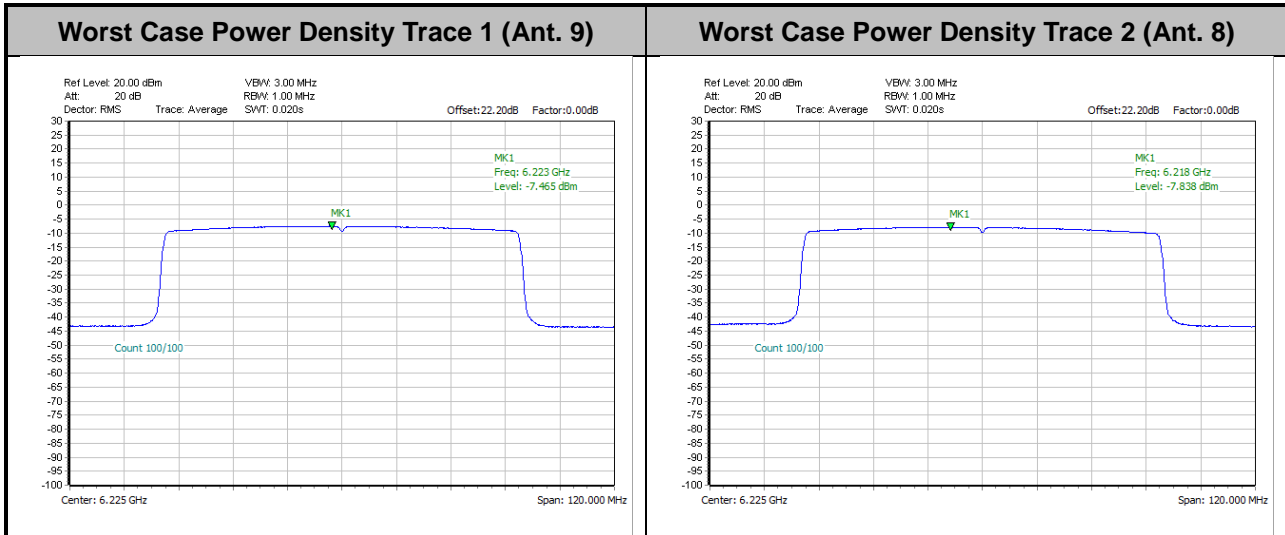



<802.11ax HE160 Mode>

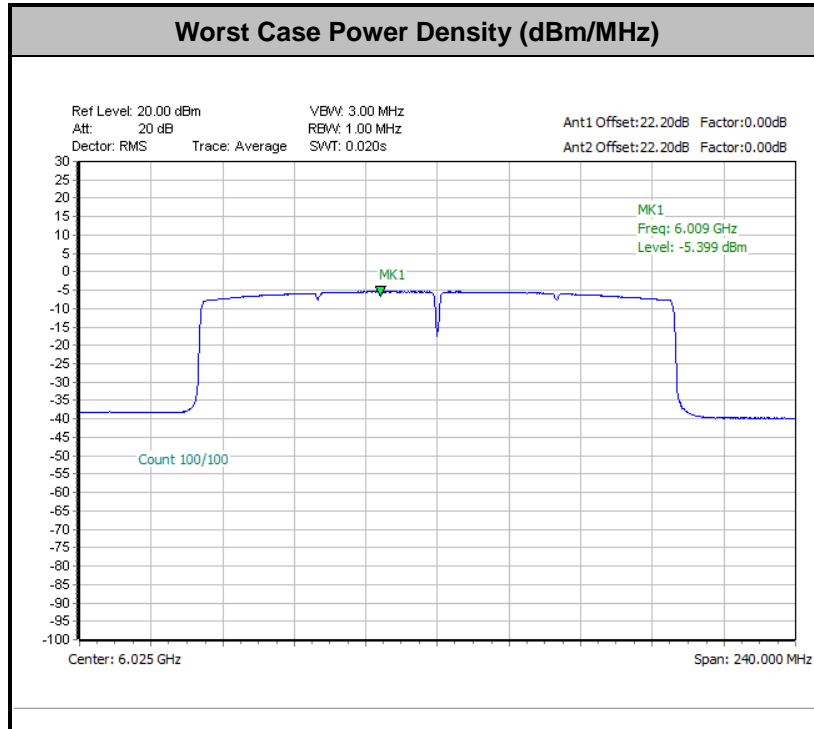

Remark: The test plot is showing a bin by bin combined result mathematically adds two traces.

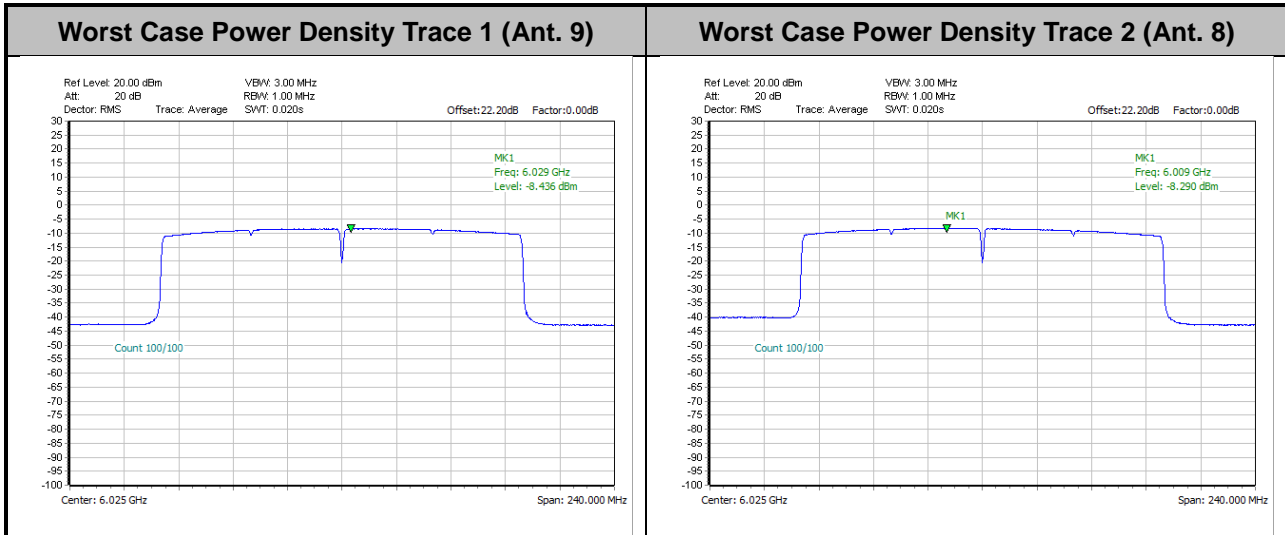



<SDM Mode>

<Standard Client>

FCC Band V MIMO_SDM Mode															
Mod.	Data Rate	NTX	CH.	Freq. (MHz)	RU Config.	Duty Factor (dB)		Conducted Power Density with Duty Factor (dBm/MHz)			DG (dBi)		EIRP Power Density (dBm/MHz)	EIRP Power Density Limit (dBm)	Pass /Fail
						Ant 9	Ant 8	Ant 9	Ant 8	SUM	Ant 9	Ant 8	SUM		
HE20	MCS0	2	001	5955	Full	0.02	0.02			2.89	3.56	6.45	17.00	Pass	
HE20	MCS0	2	001	5955	26/0	0.02	0.02			2.85	3.56	6.41	17.00	Pass	
HE20	MCS0	2	001	5955	52/37	0.02	0.02			2.87	3.56	6.43	17.00	Pass	
HE20	MCS0	2	001	5955	106/53	0.02	0.02			2.80	3.56	6.36	17.00	Pass	
HE20	MCS0	2	049	6195	Full	0.02	0.02			2.80	3.56	6.36	17.00	Pass	
HE20	MCS0	2	049	6195	26/4	0.02	0.02			2.66	3.56	6.22	17.00	Pass	
HE20	MCS0	2	049	6195	52/39	0.02	0.02			2.64	3.56	6.20	17.00	Pass	
HE20	MCS0	2	049	6195	106/53	0.02	0.02			2.77	3.56	6.33	17.00	Pass	
HE20	MCS0	2	093	6415	Full	0.02	0.02			3.17	3.56	6.73	17.00	Pass	
HE20	MCS0	2	093	6415	26/8	0.02	0.02			3.07	3.56	6.63	17.00	Pass	
HE20	MCS0	2	093	6415	52/40	0.02	0.02			3.04	3.56	6.60	17.00	Pass	
HE20	MCS0	2	093	6415	106/54	0.02	0.02			3.02	3.56	6.58	17.00	Pass	
HE40	MCS0	2	003	5965	Full	0.00	0.00			0.33	3.56	3.89	17.00	Pass	
HE40	MCS0	2	003	5965	242/61	0.00	0.00			0.10	3.56	3.66	17.00	Pass	
HE40	MCS0	2	051	6205	Full	0.00	0.00			-0.09	3.56	3.47	17.00	Pass	
HE40	MCS0	2	051	6205	242/61	0.00	0.00			-0.33	3.56	3.23	17.00	Pass	
HE40	MCS0	2	091	6405	Full	0.00	0.00			0.36	3.56	3.92	17.00	Pass	
HE40	MCS0	2	091	6405	242/62	0.00	0.00			-0.01	3.56	3.55	17.00	Pass	
HE80	MCS0	2	007	5985	Full	0.00	0.00			-2.70	3.56	0.87	17.00	Pass	
HE80	MCS0	2	007	5985	484/65	0.00	0.00			-3.04	3.56	0.52	17.00	Pass	
HE80	MCS0	2	055	6225	Full	0.00	0.00			-2.49	3.56	1.07	17.00	Pass	
HE80	MCS0	2	055	6225	484/65	0.00	0.00			-2.87	3.56	0.69	17.00	Pass	
HE80	MCS0	2	087	6385	Full	0.00	0.00			-2.35	3.56	1.22	17.00	Pass	
HE80	MCS0	2	087	6385	484/66	0.00	0.00			-2.46	3.56	1.10	17.00	Pass	
HE160	MCS0	2	015	6025	Full	0.14	0.14			-5.27	3.56	-1.71	17.00	Pass	
HE160	MCS0	2	015	6025	996/67	0.14	0.14			-5.50	3.56	-1.94	17.00	Pass	
HE160	MCS0	2	047	6185	Full	0.14	0.14			-5.36	3.56	-1.80	17.00	Pass	
HE160	MCS0	2	047	6185	996/67	0.14	0.14			-5.41	3.56	-1.85	17.00	Pass	
HE160	MCS0	2	079	6345	Full	0.14	0.14			-5.35	3.56	-1.79	17.00	Pass	
HE160	MCS0	2	079	6345	996/S67	0.14	0.14			-5.50	3.56	-1.94	17.00	Pass	



FCC Band VII MIMO_SDM Mode															
Mod.	Data Rate	NTX	CH.	Freq. (MHz)	RU Config.	Duty Factor (dB)		Conducted Power Density with Duty Factor (dBm/MHz)			DG (dBi)		EIRP Power Density (dBm/MHz)	EIRP Power Density Limit (dBm)	Pass /Fail
						Ant 9	Ant 8	Ant 9	Ant 8	SUM	Ant 9	Ant 8	SUM		
HE20	MCS0	2	117	6535	Full	0.02	0.02			2.23	3.56	5.79	17.00	Pass	
HE20	MCS0	2	117	6535	26/0	0.02	0.02			2.20	3.56	5.76	17.00	Pass	
HE20	MCS0	2	117	6535	52/37	0.02	0.02			2.22	3.56	5.78	17.00	Pass	
HE20	MCS0	2	117	6535	106/53	0.02	0.02			2.10	3.56	5.66	17.00	Pass	
HE20	MCS0	2	149	6695	Full	0.02	0.02			2.40	3.56	5.96	17.00	Pass	
HE20	MCS0	2	149	6695	26/4	0.02	0.02			1.99	3.56	5.55	17.00	Pass	
HE20	MCS0	2	149	6695	52/38	0.02	0.02			2.13	3.56	5.69	17.00	Pass	
HE20	MCS0	2	149	6695	106/53	0.02	0.02			2.36	3.56	5.92	17.00	Pass	
HE20	MCS0	2	181	6855	Full	0.02	0.02			2.39	3.56	5.95	17.00	Pass	
HE20	MCS0	2	181	6855	26/8	0.02	0.02			2.34	3.56	5.90	17.00	Pass	
HE20	MCS0	2	181	6855	52/40	0.02	0.02			1.95	3.56	5.51	17.00	Pass	
HE20	MCS0	2	181	6855	106/54	0.02	0.02			2.31	3.56	5.87	17.00	Pass	
HE40	MCS0	2	123	6565	Full	0.00	0.00			-0.41	3.56	3.15	17.00	Pass	
HE40	MCS0	2	123	6565	242/61	0.00	0.00			-0.78	3.56	2.79	17.00	Pass	
HE40	MCS0	2	147	6685	Full	0.00	0.00			-0.48	3.56	3.09	17.00	Pass	
HE40	MCS0	2	147	6685	242/61	0.00	0.00			-0.76	3.56	2.80	17.00	Pass	
HE40	MCS0	2	179	6845	Full	0.00	0.00			0.10	3.56	3.66	17.00	Pass	
HE40	MCS0	2	179	6845	242/62	0.00	0.00			-0.36	3.56	3.20	17.00	Pass	
HE80	MCS0	2	135	6625	Full	0.00	0.00			-3.21	3.56	0.35	17.00	Pass	
HE80	MCS0	2	135	6625	484/65	0.00	0.00			-3.38	3.56	0.18	17.00	Pass	
HE80	MCS0	2	151	6705	Full	0.00	0.00			-3.33	3.56	0.23	17.00	Pass	
HE80	MCS0	2	151	6705	484/65	0.00	0.00			-3.36	3.56	0.20	17.00	Pass	
HE80	MCS0	2	167	6785	Full	0.00	0.00			-2.96	3.56	0.60	17.00	Pass	
HE80	MCS0	2	167	6785	484/66	0.00	0.00			-3.03	3.56	0.53	17.00	Pass	
HE160	MCS0	2	143	6665	Full	0.00	0.00			-5.90	3.56	-2.34	17.00	Pass	
HE160	MCS0	2	143	6665	996/67	0.00	0.00			-6.30	3.56	-2.74	17.00	Pass	
HE160	MCS0	2	175	6825	Full	0.00	0.00			-5.59	3.56	-2.03	17.00	Pass	
HE160	MCS0	2	175	6825	996/S67	0.00	0.00			-5.93	3.56	-2.37	17.00	Pass	



<802.11ax HE20 Mode>

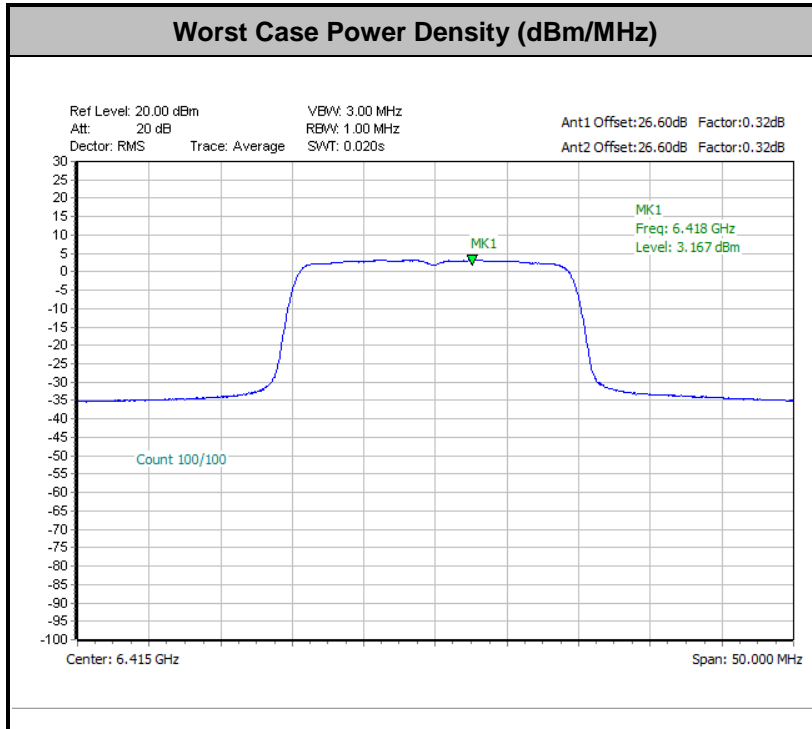

Remark: The test plot is showing a bin by bin combined result mathematically adds two traces.

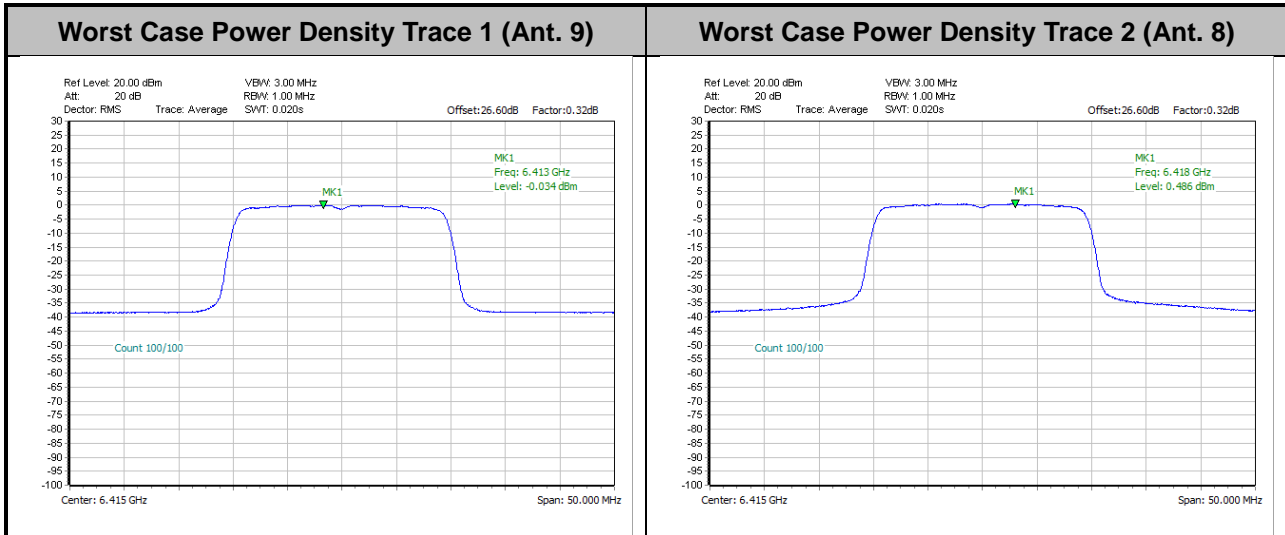



<802.11ax HE40 Mode>

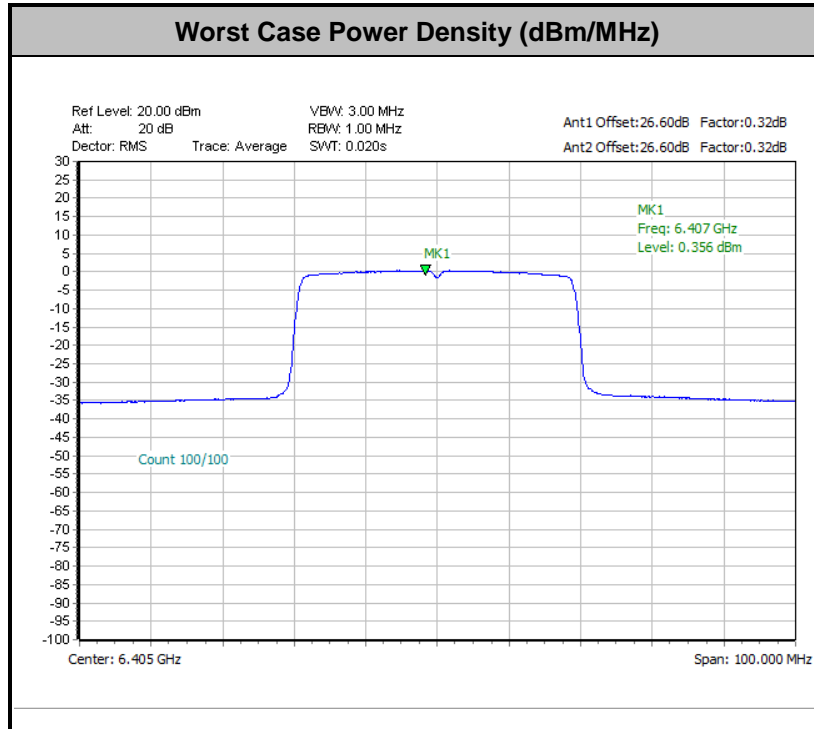

Remark: The test plot is showing a bin by bin combined result mathematically adds two traces.

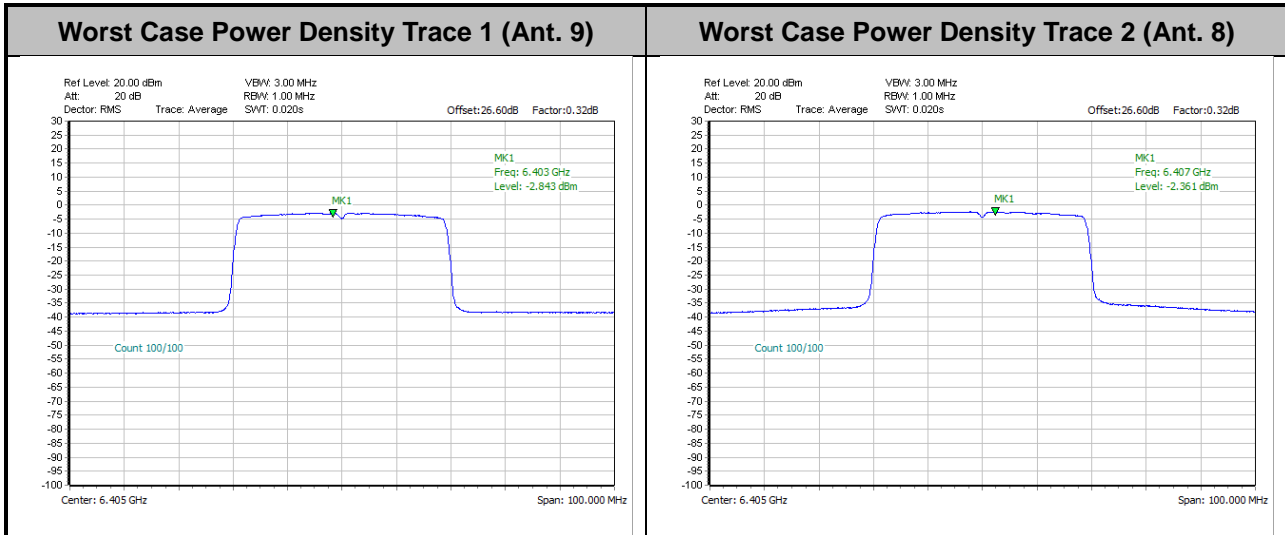



<802.11ax HE80 Mode>

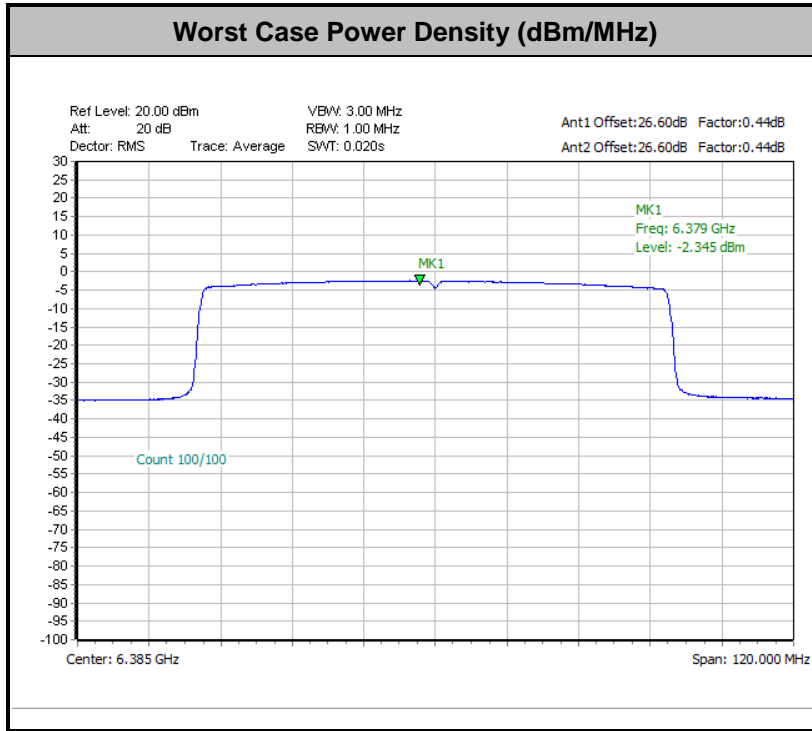

Remark: The test plot is showing a bin by bin combined result mathematically adds two traces.

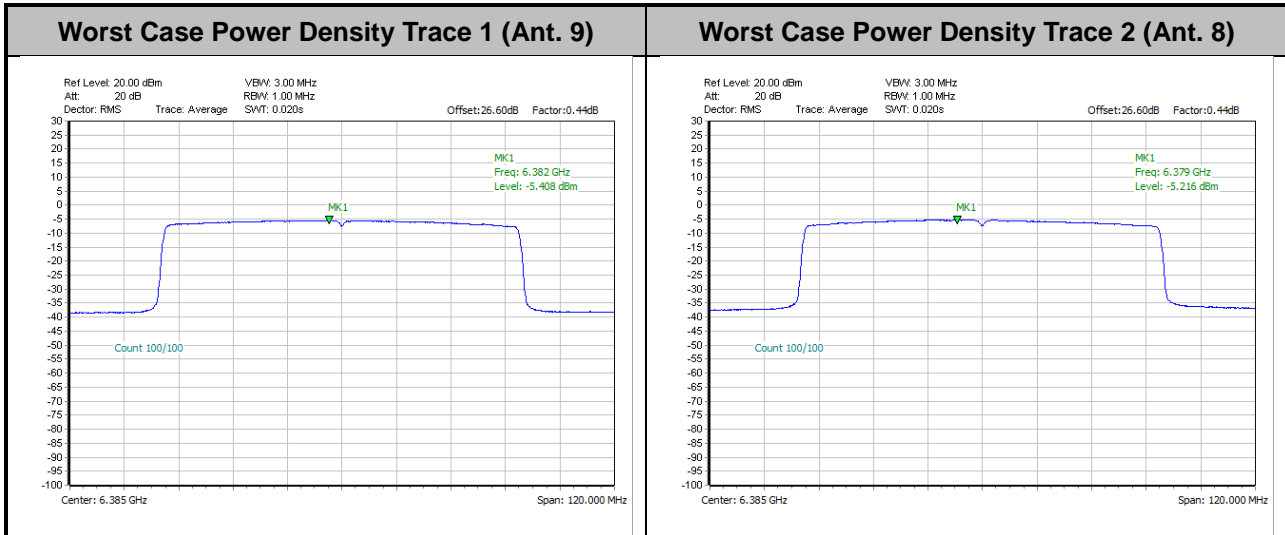



<802.11ax HE160 Mode>

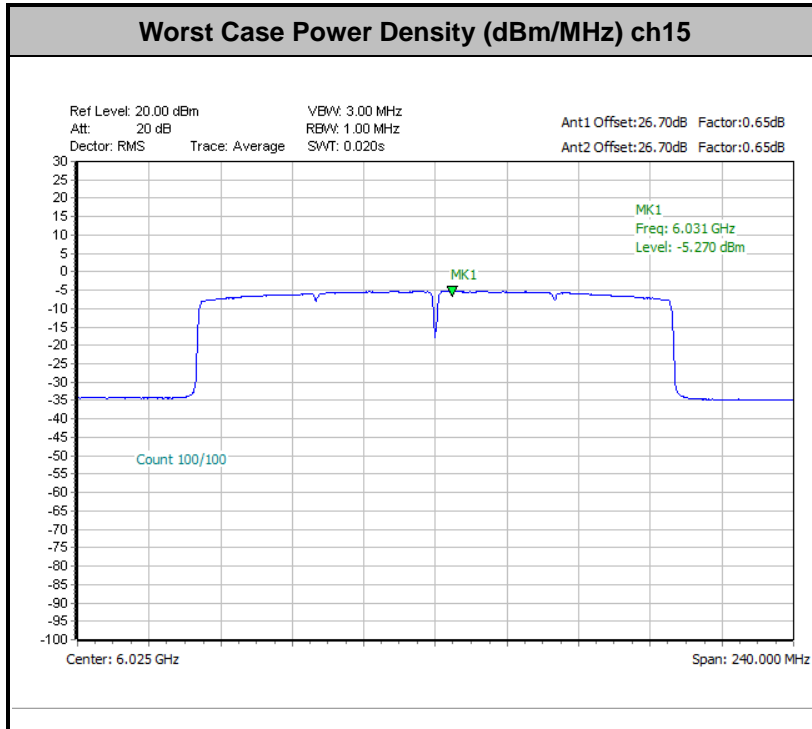

Remark: The test plot is showing a bin by bin combined result mathematically adds two traces.

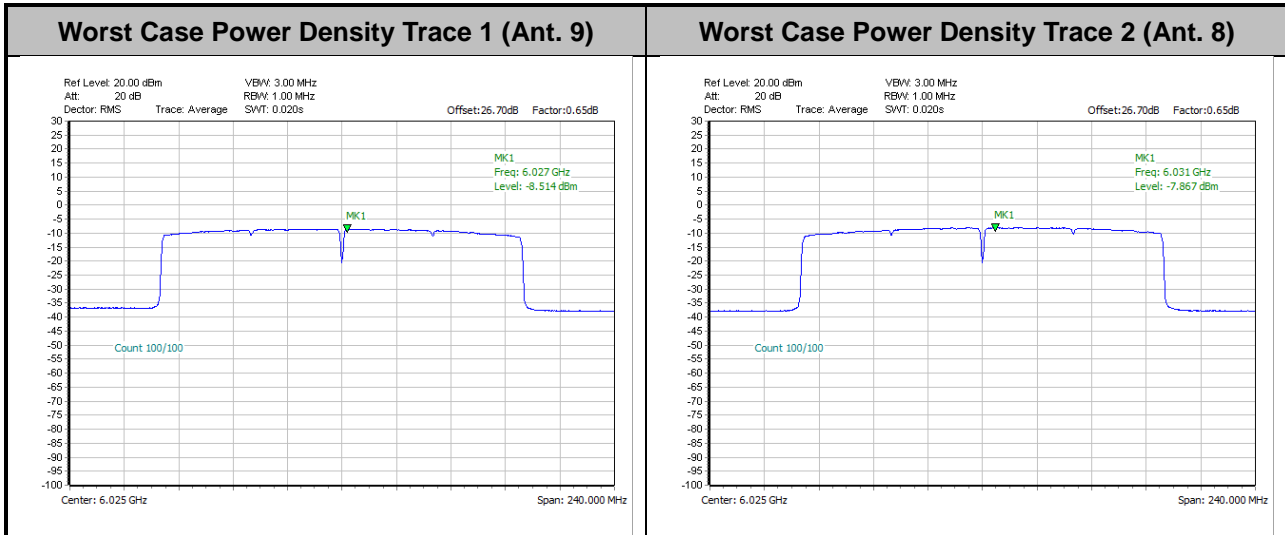



<CDD Mode>

<Indoor Client>

FCC Band V MIMO_CDD Mode														
Mod.	Data Rate	NTX	CH.	Freq. (MHz)	Duty Factor (dB)		Conducted Power Density with Duty Factor (dBm/MHz)			DG (dBi)		EIRP Power Density (dBm/MHz)	EIRP Power Density Limit (dBm)	Pass /Fail
					Ant 9	Ant 8	Ant 9	Ant 8	SUM	Ant 9	Ant 8	SUM		
11a	6Mbps	2	001	5955	0.04	0.04	-	-7.73	6.57	-1.16	-1.00	Pass		
11a	6Mbps	2	049	6195	0.04	0.04		-7.67	6.57	-1.10	-1.00	Pass		
11a	6Mbps	2	093	6415	0.04	0.04		-7.58	6.57	-1.02	-1.00	Pass		

FCC Band VI MIMO_CDD Mode														
Mod.	Data Rate	NTX	CH.	Freq. (MHz)	Duty Factor (dB)		Conducted Power Density with Duty Factor (dBm/MHz)			DG (dBi)		EIRP Power Density (dBm/MHz)	EIRP Power Density Limit (dBm)	Pass /Fail
					Ant 9	Ant 8	Ant 9	Ant 8	SUM	Ant 9	Ant 8	SUM		
11a	6Mbps	2	097	6435	0.04	0.04	-	-7.58	6.57	-1.02	-1.00	Pass		
11a	6Mbps	2	105	6475	0.04	0.04		-7.89	6.57	-1.32	-1.00	Pass		
11a	6Mbps	2	113	6515	0.04	0.04		-8.00	6.57	-1.43	-1.00	Pass		

FCC Band VII MIMO_CDD Mode														
Mod.	Data Rate	NTX	CH.	Freq. (MHz)	Duty Factor (dB)		Conducted Power Density with Duty Factor (dBm/MHz)			DG (dBi)		EIRP Power Density (dBm/MHz)	EIRP Power Density Limit (dBm)	Pass /Fail
					Ant 9	Ant 8	Ant 9	Ant 8	SUM	Ant 9	Ant 8	SUM		
11a	6Mbps	2	117	6535	0.04	0.04	-	-8.02	6.57	-1.45	-1.00	Pass		
11a	6Mbps	2	149	6695	0.04	0.04		-7.91	6.57	-1.34	-1.00	Pass		
11a	6Mbps	2	181	6855	0.04	0.04		-7.81	6.57	-1.24	-1.00	Pass		



FCC Band VIII MIMO_CDD Mode														
Mod.	Data Rate	NTX	CH.	Freq. (MHz)	Duty Factor (dB)		Conducted Power Density with Duty Factor (dBm/MHz)			DG (dBi)		EIRP Power Density (dBm/MHz)	EIRP Power Density Limit (dBm)	Pass /Fail
					Ant 9	Ant 8	Ant 9	Ant 8	SUM	Ant 9	Ant 8	SUM		
11a	6Mbps	2	189	6895	0.04	0.04	-			-8.07	6.96	-1.11	-1.00	Pass
11a	6Mbps	2	209	6995	0.04	0.04				-8.03	6.96	-1.07	-1.00	Pass
11a	6Mbps	2	229	7095	0.04	0.04				-8.14	6.96	-1.18	-1.00	Pass
11a	6Mbps	2	233	7115	0.04	0.04				-7.99	6.96	-1.03	-1.00	Pass

FCC Band VIII straddle channel MIMO_CDD Mode														
Mod.	Data Rate	NTX	CH.	Freq. (MHz)	Duty Factor (dB)		Conducted Power Density with Duty Factor (dBm/MHz)			DG (dBi)		EIRP Power Density (dBm/MHz)	EIRP Power Density Limit (dBm)	Pass /Fail
					Ant 9	Ant 8	Ant 9	Ant 8	SUM	Ant 9	Ant 8	SUM		
11a	6Mbps	2	185	6875	0.04	0.04			-	-8.32	6.96	-1.36	-1.00	Pass



<802.11a Mode>

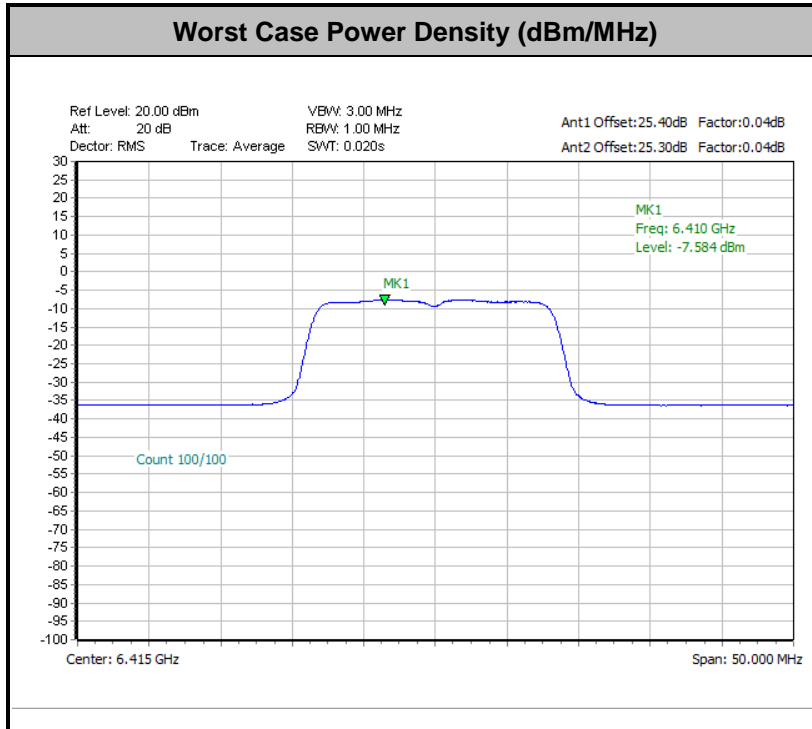

Remark: The test plot is showing a bin by bin combined result mathematically adds two traces.

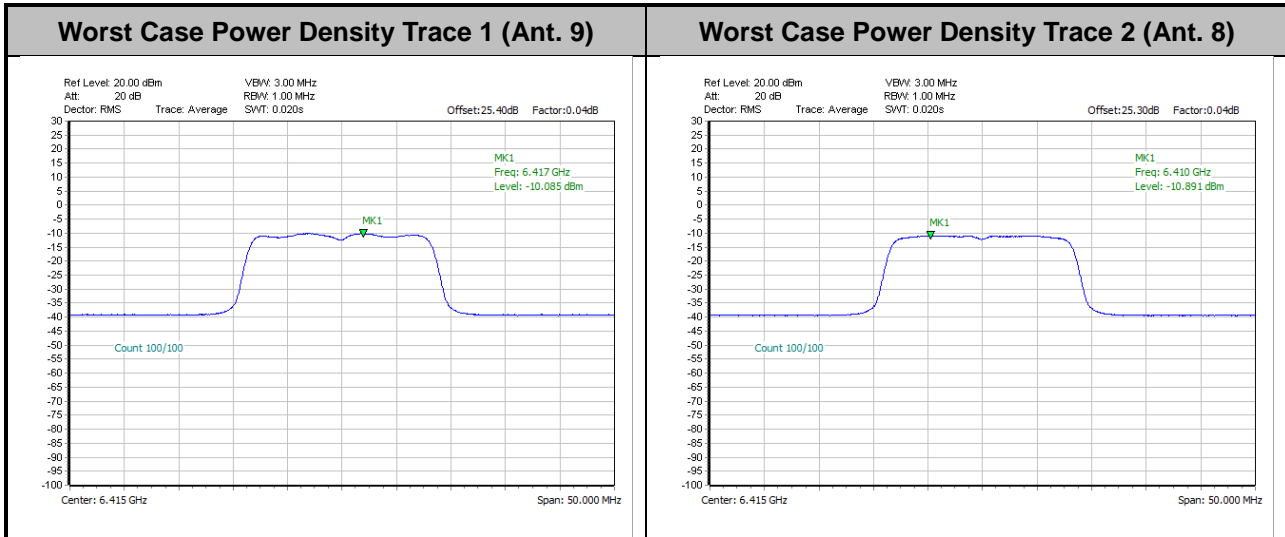



<CDD Mode>

<Standard Client>

FCC Band V MIMO_CDD Mode														
Mod.	Data Rate	NTX	CH.	Freq. (MHz)	Duty Factor (dB)		Conducted Power Density with Duty Factor (dBm/MHz)			DG (dBi)		EIRP Power Density (dBm/MHz)	EIRP Power Density Limit (dBm)	Pass /Fail
					Ant 9	Ant 8	Ant 9	Ant 8	SUM	Ant 9	Ant 8	SUM		
11a	6Mbps	2	001	5955	0.04	0.04	-		3.47	6.57	10.03	17.00	Pass	
11a	6Mbps	2	049	6195	0.04	0.04			3.25	6.57	9.82	17.00	Pass	
11a	6Mbps	2	093	6415	0.04	0.04			3.05	6.57	9.61	17.00	Pass	

FCC Band VII MIMO_CDD Mode														
Mod.	Data Rate	NTX	CH.	Freq. (MHz)	Duty Factor (dB)		Conducted Power Density with Duty Factor (dBm/MHz)			DG (dBi)		EIRP Power Density (dBm/MHz)	EIRP Power Density Limit (dBm)	Pass /Fail
					Ant 9	Ant 8	Ant 9	Ant 8	SUM	Ant 9	Ant 8	SUM		
11a	6Mbps	2	117	6535	0.04	0.04	-		2.58	6.57	9.15	17.00	Pass	
11a	6Mbps	2	149	6695	0.04	0.04			2.59	6.57	9.16	17.00	Pass	
11a	6Mbps	2	181	6855	0.04	0.04			2.47	6.57	9.04	17.00	Pass	



<802.11a Mode>

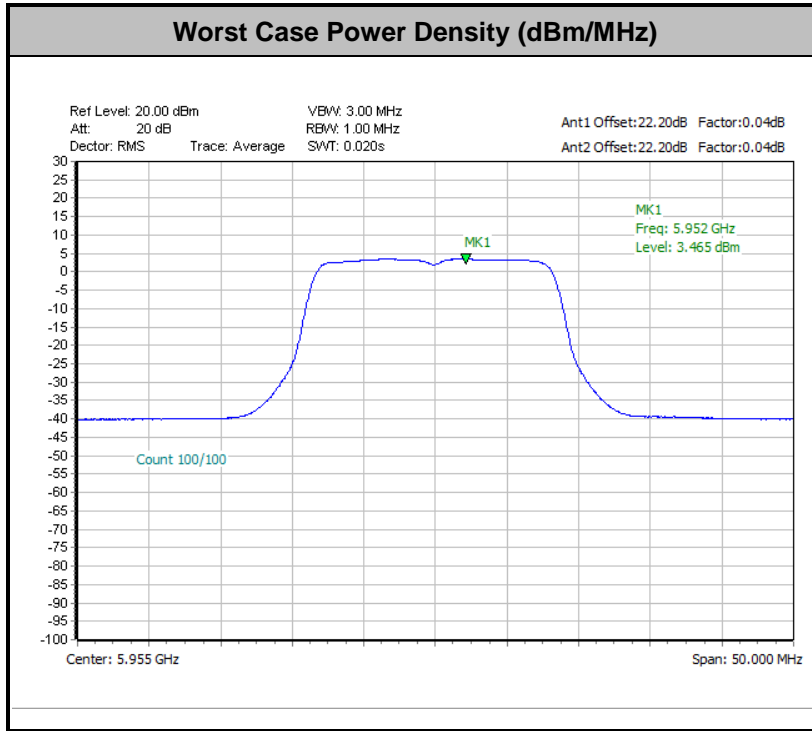

Remark: The test plot is showing a bin by bin combined result mathematically adds two traces.

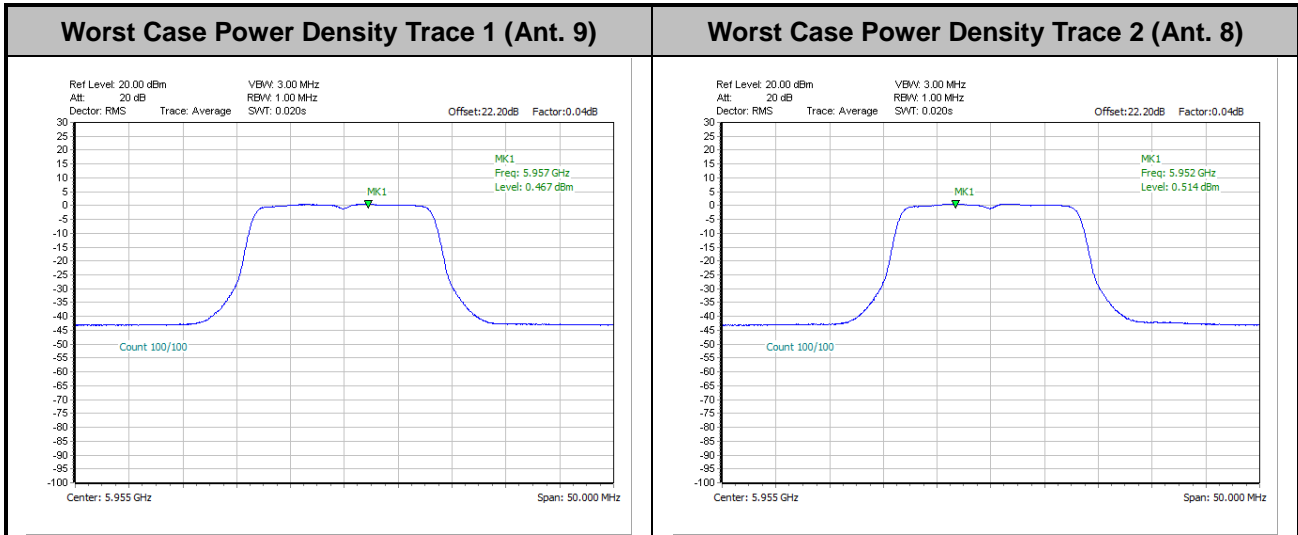



<TXBF Mode>

<Indoor Client>

FCC Band V MIMO_TXBF Mode													
Mod.	Data Rate	NTX	CH.	Freq. (MHz)	RU Config.	Conducted Power Density (dBm/MHz)			DG (dBi)		EIRP Power Density (dBm/MHz)	EIRP Power Density Limit (dBm)	Pass /Fail
						Ant 9	Ant 8	SUM	Ant 9	Ant 8	SUM		
HE20	MCS3	2	049	6195	Full			-7.97	6.57	-1.40	-1.00	Pass	
HE20	MCS3	2	093	6415	Full			-8.19	6.57	-1.62	-1.00	Pass	
HE40	MCS0	2	051	6205	Full			-7.91	6.57	-1.34	-1.00	Pass	
HE40	MCS0	2	091	6405	Full			-7.91	6.57	-1.34	-1.00	Pass	
HE80	MCS0	2	055	6225	Full			-8.07	6.57	-1.50	-1.00	Pass	
HE80	MCS0	2	087	6385	Full			-8.14	6.57	-1.57	-1.00	Pass	
HE160	MCS0	2	047	6185	Full			-8.01	6.57	-1.44	-1.00	Pass	
HE160	MCS0	2	079	6345	Full			-8.34	6.57	-1.77	-1.00	Pass	

Band VI MIMO_TXBF Mode													
Mod.	Data Rate	NTX	CH.	Freq. (MHz)	RU Config.	Conducted Power Density (dBm/MHz)			DG (dBi)		EIRP Power Density (dBm/MHz)	EIRP Power Density Limit (dBm)	Pass /Fail
						Ant 9	Ant 8	SUM	Ant 9	Ant 8	SUM		
HE20	MCS0	2	097	6435	Full			-8.04	6.57	-1.47	-1.00	Pass	
HE20	MCS0	2	105	6475	Full			-8.04	6.57	-1.47	-1.00	Pass	
HE20	MCS0	2	113	6515	Full			-8.17	6.57	-1.61	-1.00	Pass	
HE40	MCS0	2	099	6445	Full			-8.36	6.57	-1.79	-1.00	Pass	
HE40	MCS0	2	107	6485	Full			-8.53	6.57	-1.96	-1.00	Pass	
HE80	MCS0	2	103	6465	Full			-7.60	6.57	-1.03	-1.00	Pass	



FCC Band VI straddle channel MIMO_TXBF Mode													
Mod.	Data Rate	NTX	CH.	Freq. (MHz)	RU Config.	Conducted Power Density (dBm/MHz)			DG (dBi)		EIRP Power Density (dBm/MHz)	EIRP Power Density Limit (dBm)	Pass /Fail
						Ant 9	Ant 8	SUM	Ant 9	Ant 8	SUM		
HE40	MCS0	2	115	6525	Full			-8.37	6.57	-1.81	-1.00	Pass	
HE80	MCS0	2	119	6545	Full			-7.92	6.57	-1.35	-1.00	Pass	
HE160	MCS0	2	111	6505	Full			-8.90	6.57	-2.33	-1.00	Pass	

FCC Band VII MIMO_TXBF Mode													
Mod.	Data Rate	NTX	CH.	Freq. (MHz)	RU Config.	Conducted Power Density (dBm/MHz)			DG (dBi)		EIRP Power Density (dBm/MHz)	EIRP Power Density Limit (dBm)	Pass /Fail
						Ant 9	Ant 8	SUM	Ant 9	Ant 8	SUM		
HE20	MCS0	2	117	6535	Full			-7.98	6.57	-1.41	-1.00	Pass	
HE20	MCS0	2	149	6695	Full			-7.82	6.57	-1.25	-1.00	Pass	
HE20	MCS0	2	181	6855	Full			-7.91	6.57	-1.34	-1.00	Pass	
HE40	MCS0	2	123	6565	Full			-8.19	6.57	-1.63	-1.00	Pass	
HE40	MCS0	2	147	6685	Full			-8.13	6.57	-1.56	-1.00	Pass	
HE40	MCS0	2	179	6845	Full			-7.81	6.57	-1.24	-1.00	Pass	
HE80	MCS0	2	135	6625	Full			-7.79	6.57	-1.22	-1.00	Pass	
HE80	MCS0	2	151	6705	Full			-8.08	6.57	-1.51	-1.00	Pass	
HE80	MCS0	2	167	6785	Full			-7.84	6.57	-1.27	-1.00	Pass	
HE160	MCS0	2	143	6665	Full			-8.53	6.57	-1.96	-1.00	Pass	



FCC Band VIII MIMO_TXBF Mode													
Mod.	Data Rate	NTX	CH.	Freq. (MHz)	RU Config.	Conducted Power Density (dBm/MHz)			DG (dBi)		EIRP Power Density (dBm/MHz)	EIRP Power Density Limit (dBm)	Pass /Fail
						Ant 9	Ant 8	SUM	Ant 9	Ant 8	SUM		
HE20	MCS0	2	189	6895	Full			-8.23	6.96	-1.27	-1.00	Pass	
HE20	MCS0	2	209	6995	Full			-8.34	6.96	-1.38	-1.00	Pass	
HE20	MCS0	2	229	7095	Full			-8.34	6.96	-1.38	-1.00	Pass	
HE20	MCS0	2	233	7115	Full			-17.38	6.96	-10.42	-1.00	Pass	
HE40	MCS0	2	195	6925	Full			-8.17	6.96	-1.21	-1.00	Pass	
HE40	MCS0	2	211	7005	Full			-8.34	6.96	-1.38	-1.00	Pass	
HE40	MCS0	2	227	7085	Full			-8.15	6.96	-1.19	-1.00	Pass	
HE80	MCS0	2	199	6945	Full			-8.72	6.96	-1.76	-1.00	Pass	
HE80	MCS0	2	215	7025	Full			-8.31	6.96	-1.35	-1.00	Pass	
HE160	MCS0	2	207	6985	Full			-8.47	6.96	-1.51	-1.00	Pass	

FCC Band VIII straddle channel MIMO_TXBF Mode													
Mod.	Data Rate	NTX	CH.	Freq. (MHz)	RU Config.	Conducted Power Density with Duty Factor (dBm/MHz)			DG (dBi)		EIRP Power Density (dBm/MHz)	EIRP Power Density Limit (dBm)	Pass /Fail
						Ant 9	Ant 8	SUM	Ant 9	Ant 8	SUM		
HE20	MCS0	2	185	6875	Full			-8.10	6.96	-1.14	-1.00	Pass	
HE40	MCS0	2	187	6885	Full			-8.51	6.96	-1.55	-1.00	Pass	
HE80	MCS0	2	183	6865	Full			-8.26	6.96	-1.30	-1.00	Pass	
HE160	MCS0	2	175	6825	Full			-8.83	6.96	-1.87	-1.00	Pass	



<802.11ax HE20 Mode>

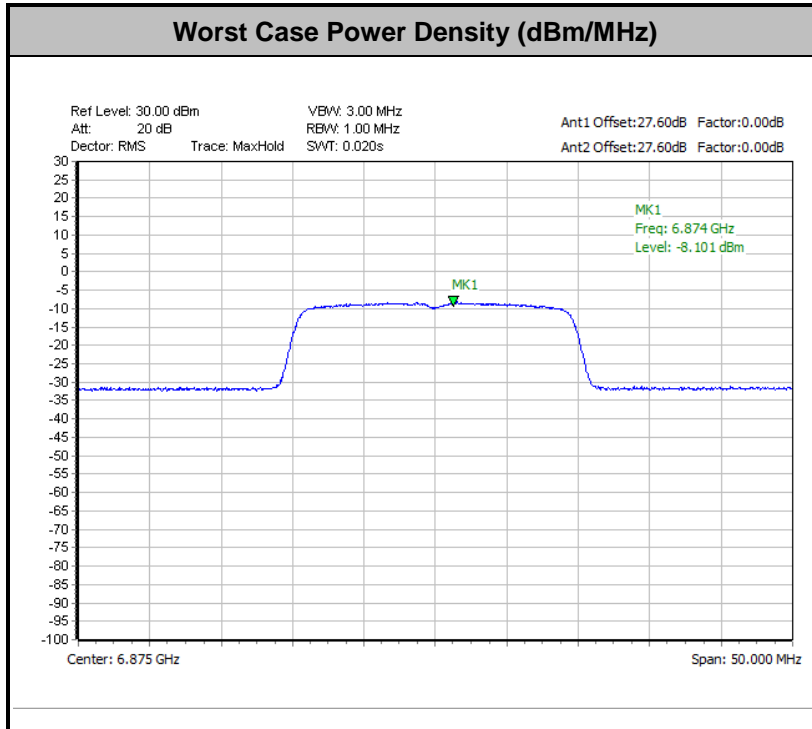

Remark: The test plot is showing a bin by bin combined result mathematically adds two traces.

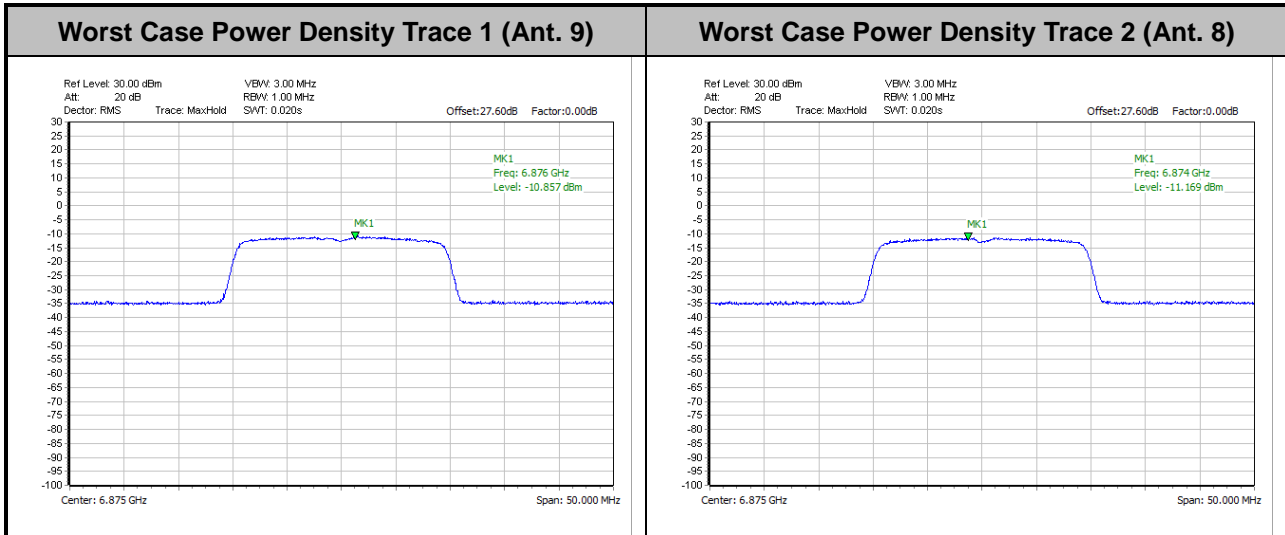



<802.11ax HE40 Mode>

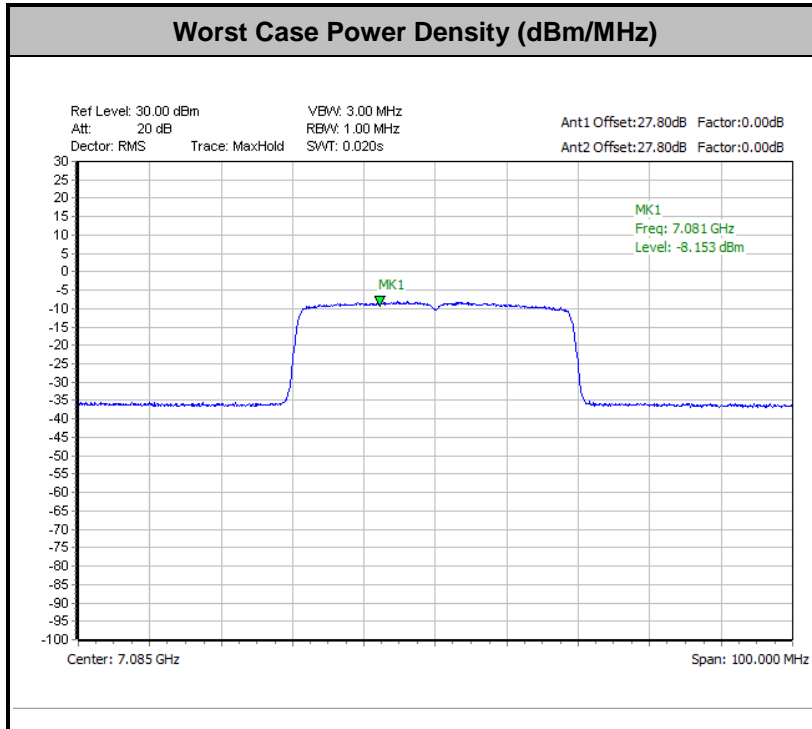

Remark: The test plot is showing a bin by bin combined result mathematically adds two traces.

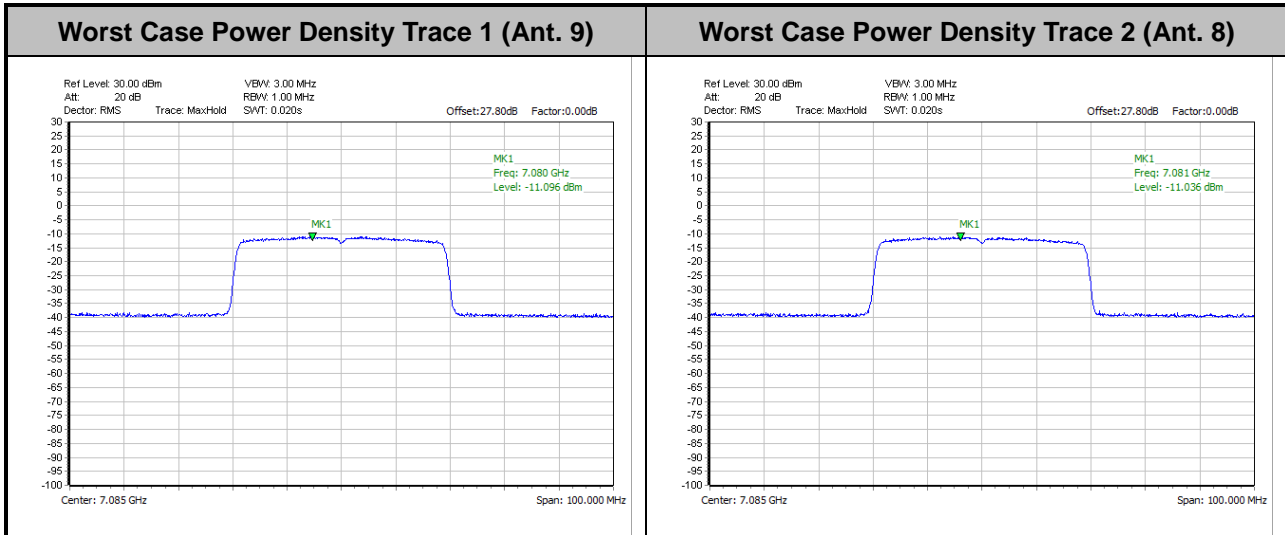



<802.11ax HE80 Mode>

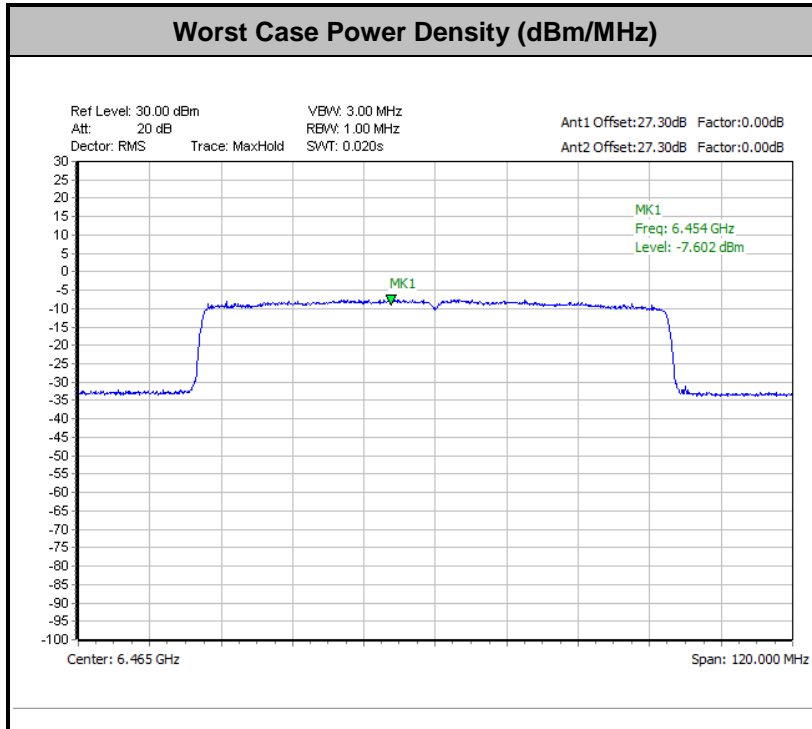

Remark: The test plot is showing a bin by bin combined result mathematically adds two traces.

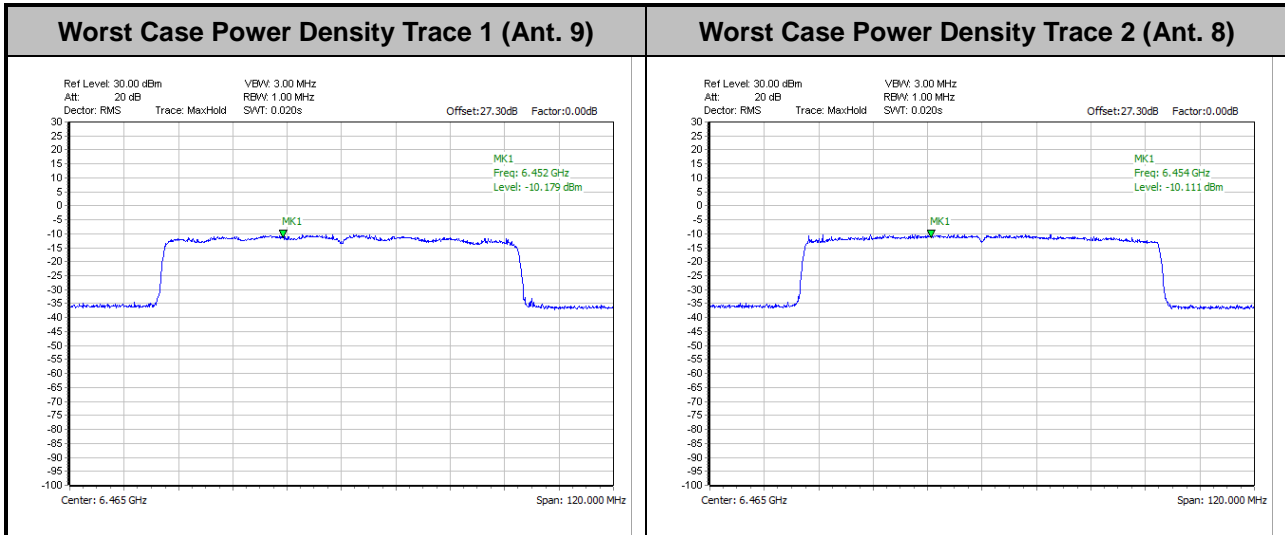



<802.11ax HE160 Mode>

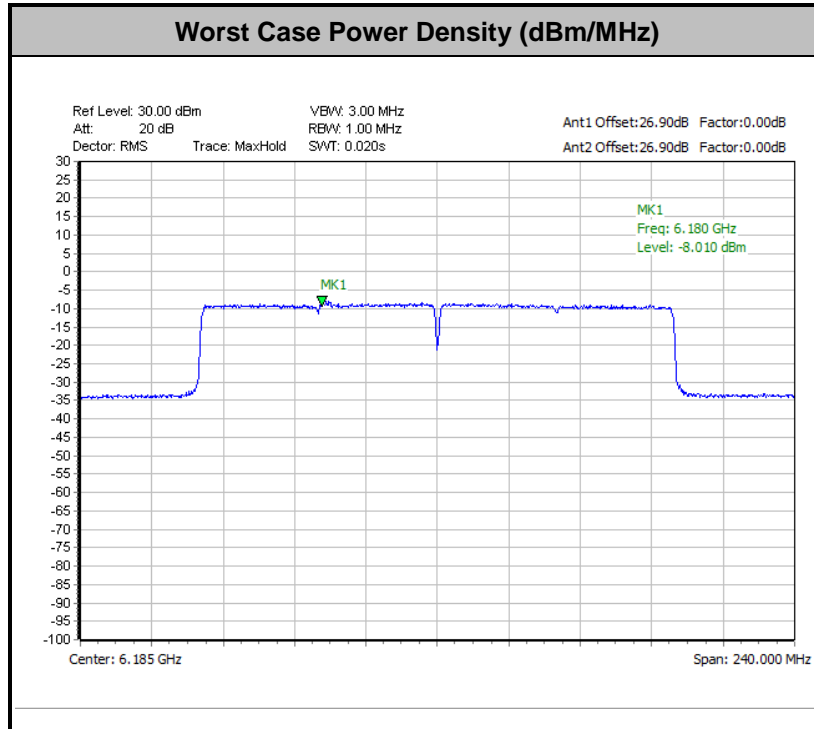

Remark: The test plot is showing a bin by bin combined result mathematically adds two traces.

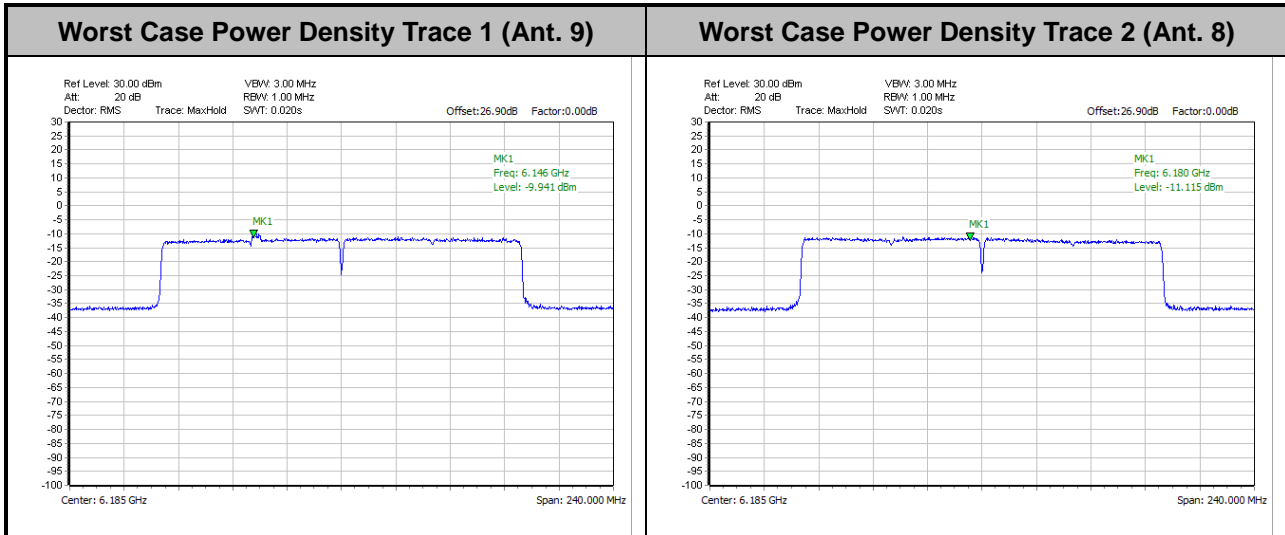



<TXBF Mode>

<Standard Client>

FCC Band V MIMO_TXBF Mode													
Mod.	Data Rate	NTX	CH.	Freq. (MHz)	RU Config.	Conducted Power Density (dBm/MHz)			DG (dBi)		EIRP Power Density (dBm/MHz)	EIRP Power Density Limit (dBm)	Pass /Fail
						Ant 9	Ant 8	SUM	Ant 9	Ant 8	SUM		
HE20	MCS3	2	049	6195	Full			0.94	6.57		7.51	17.00	Pass
HE20	MCS3	2	093	6415	Full			1.43	6.57		8.00	17.00	Pass
HE40	MCS0	2	051	6205	Full			-2.59	6.57		3.97	17.00	Pass
HE40	MCS0	2	091	6405	Full			-1.71	6.57		4.86	17.00	Pass
HE80	MCS0	2	055	6225	Full			-4.97	6.57		1.60	17.00	Pass
HE80	MCS0	2	087	6385	Full			-5.28	6.57		1.29	17.00	Pass
HE160	MCS0	2	047	6185	Full			-8.10	6.57		-1.53	17.00	Pass
HE160	MCS0	2	079	6345	Full			-7.51	6.57		-0.94	17.00	Pass



FCC Band VII MIMO_TXBF Mode													
Mod.	Data Rate	NTX	CH.	Freq. (MHz)	RU Config.	Conducted Power Density (dBm/MHz)			DG (dBi)		EIRP Power Density (dBm/MHz)	EIRP Power Density Limit (dBm)	Pass /Fail
						Ant 9	Ant 8	SUM	Ant 9	Ant 8	SUM		
HE20	MCS0	2	117	6535	Full			2.33	6.57	8.90	17.00	Pass	
HE20	MCS0	2	149	6695	Full			1.59	6.57	8.16	17.00	Pass	
HE20	MCS0	2	181	6855	Full			1.71	6.57	8.28	17.00	Pass	
HE40	MCS0	2	123	6565	Full			-3.01	6.57	3.55	17.00	Pass	
HE40	MCS0	2	147	6685	Full			-3.19	6.57	3.38	17.00	Pass	
HE40	MCS0	2	179	6845	Full			-2.62	6.57	3.94	17.00	Pass	
HE80	MCS0	2	135	6625	Full			-5.74	6.57	0.82	17.00	Pass	
HE80	MCS0	2	151	6705	Full			-5.88	6.57	0.69	17.00	Pass	
HE80	MCS0	2	167	6785	Full			-5.80	6.57	0.77	17.00	Pass	
HE160	MCS0	2	143	6665	Full			-8.53	6.57	-1.96	17.00	Pass	
HE160	MCS0	2	175	6825	Full			-9.23	6.57	-2.66	17.00	Pass	



<802.11ax HE20 Mode>

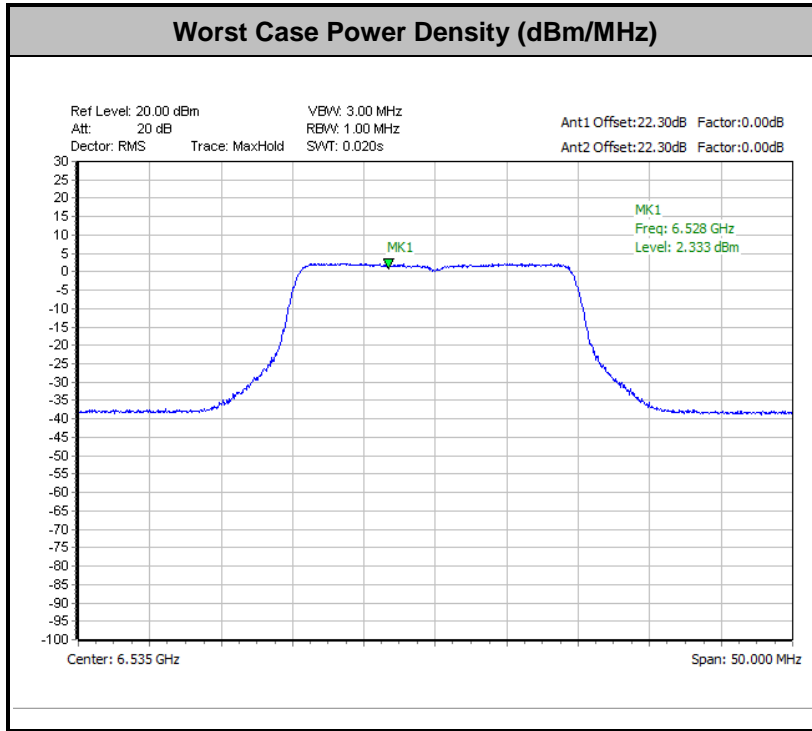

Remark: The test plot is showing a bin by bin combined result mathematically adds two traces.

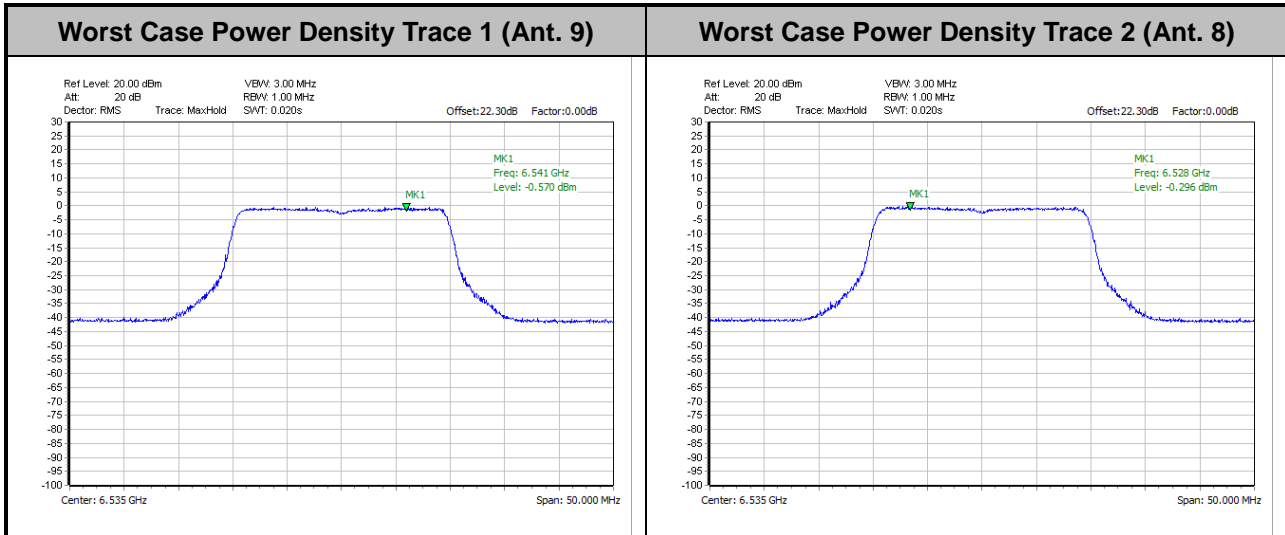



<802.11ax HE40 Mode>

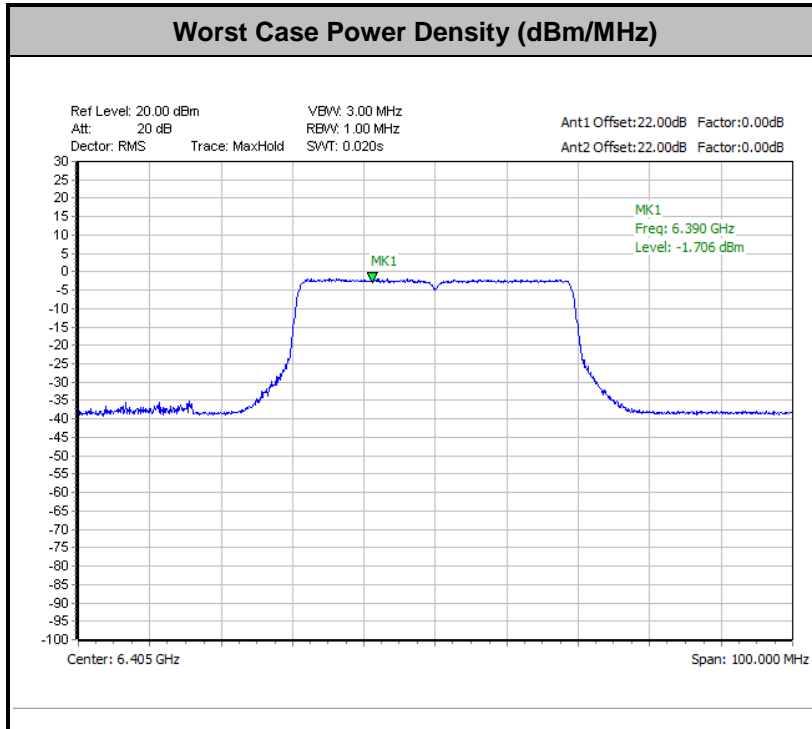

Remark: The test plot is showing a bin by bin combined result mathematically adds two traces.

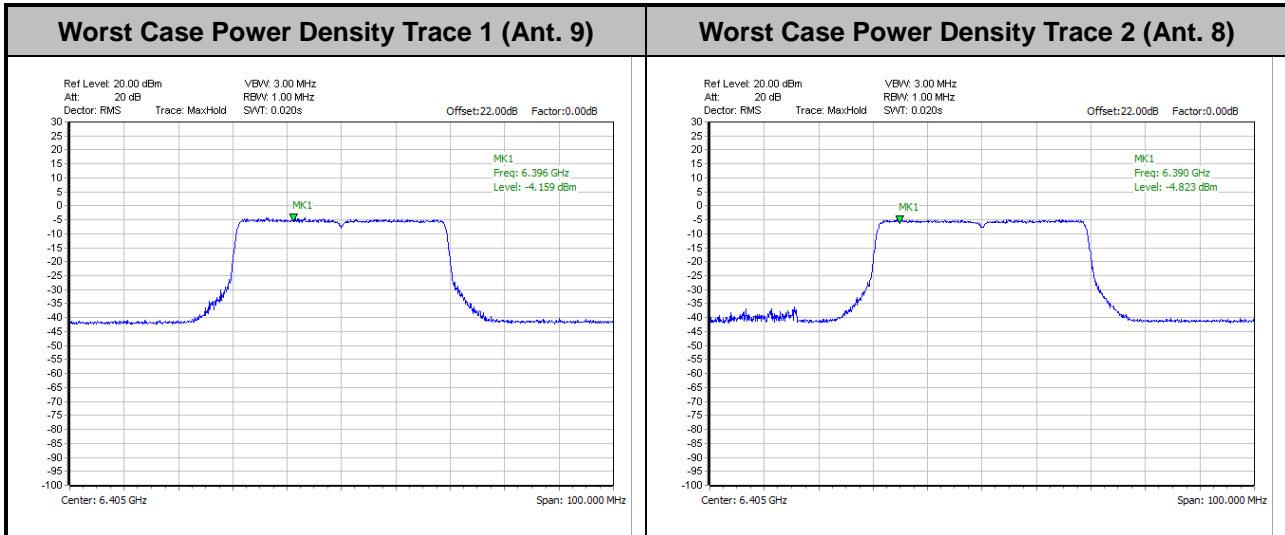



<802.11ax HE80 Mode>

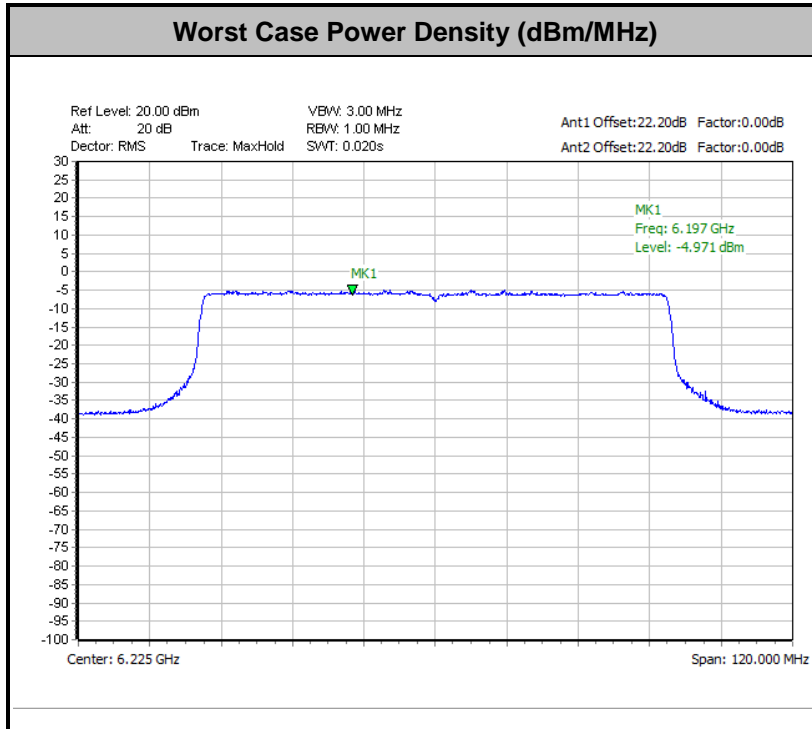

Remark: The test plot is showing a bin by bin combined result mathematically adds two traces.

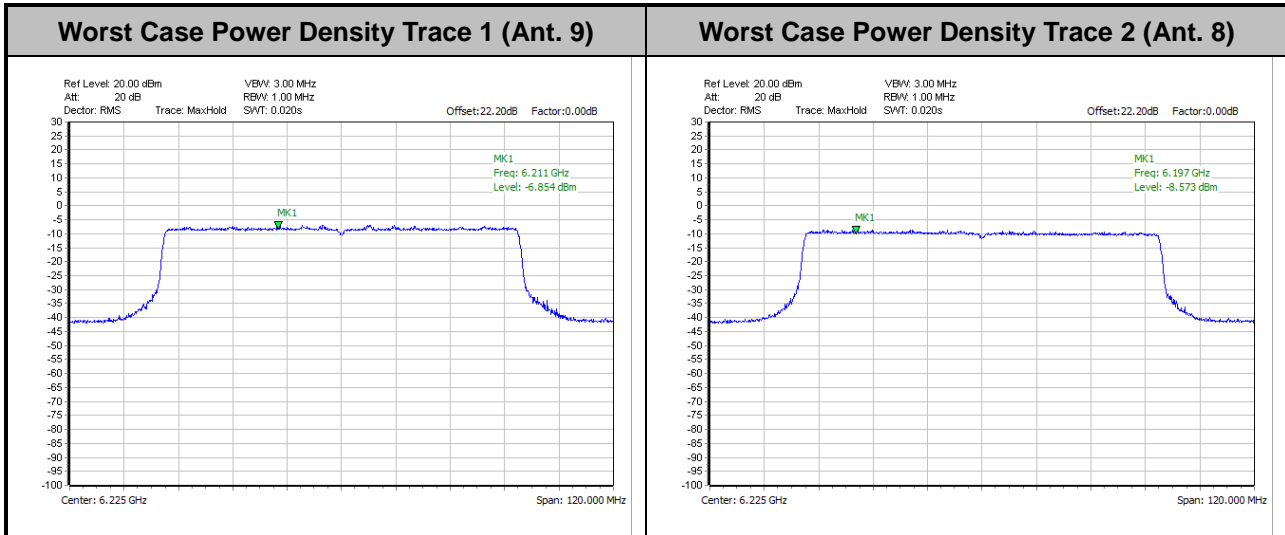



<802.11ax HE160 Mode>

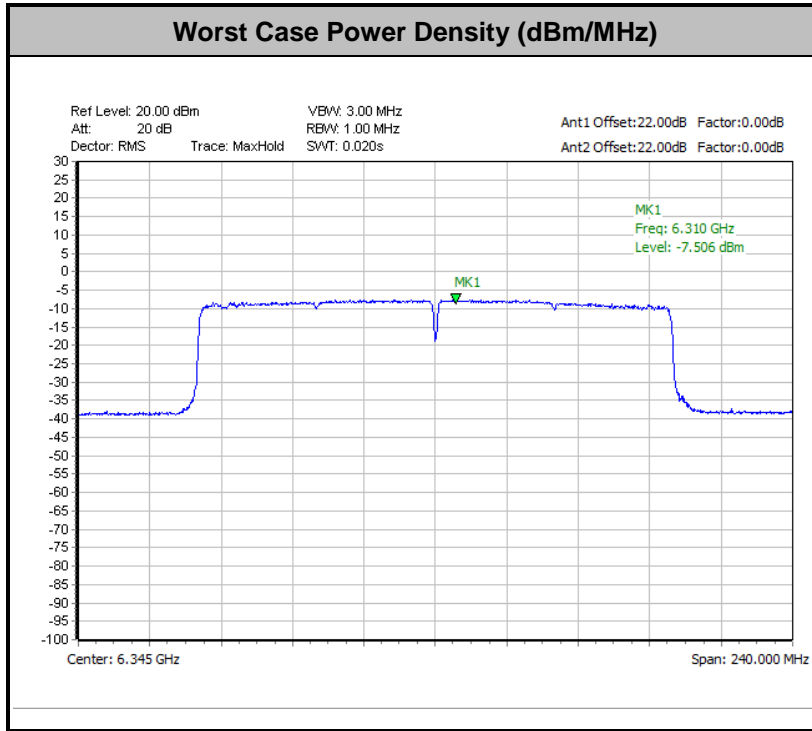

Remark: The test plot is showing a bin by bin combined result mathematically adds two traces.

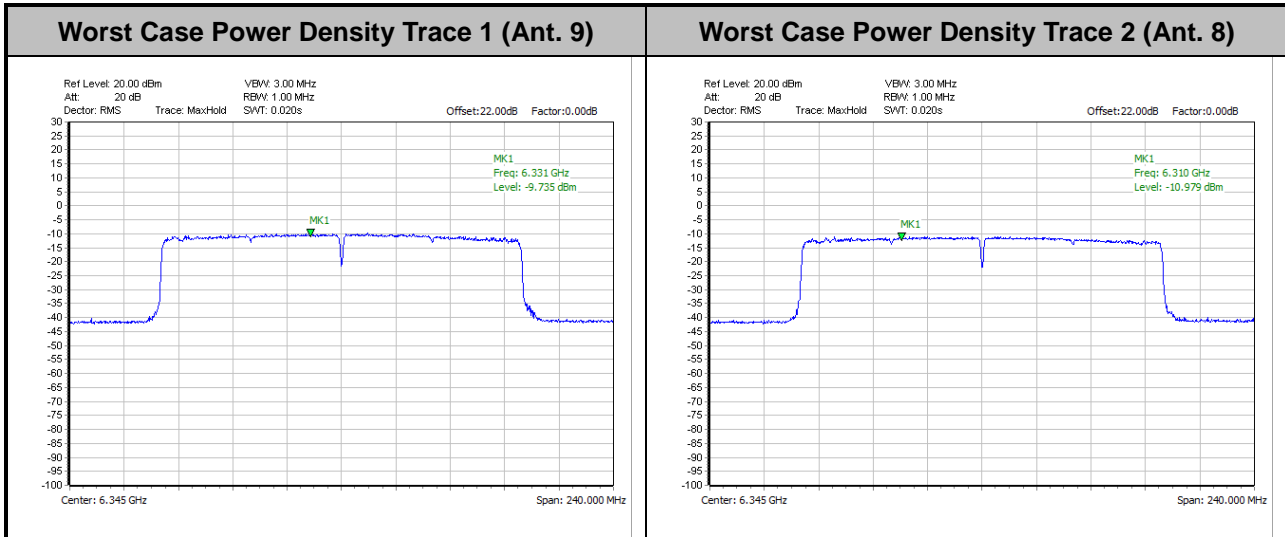



3.4 In-Band Emissions (Channel Mask)

3.4.1 Limit of Unwanted Emissions

<FCC 14-30 CFR 15.407>

(a)(6) For transmitters operating within the 5.925-7.125 GHz bands: Power spectral density must be suppressed by 20 dB at 1 MHz outside of channel edge, by 28 dB at one channel bandwidth from the channel center, and by 40 dB at one- and one-half times the channel bandwidth away from channel center. At frequencies between one megahertz outside an unlicensed device's channel edge and one channel bandwidth from the center of the channel, the limits must be linearly interpolated between 20 dB and 28 dB suppression, and at frequencies between one and one- and one-half times an unlicensed device's channel bandwidth, the limits must be linearly interpolated between 28 dB and 40 dB suppression. Emissions removed from the channel center by more than one- and one-half times the channel bandwidth must be suppressed by at least 40 dB.

3.4.2 Measuring Instruments

Please refer to the measuring equipment list in this test report.

3.4.3 Test Procedures

The testing follows FCC KDB 987594 D02 U-NII 6GHz EMC Measurement v01.

Section J) In-Band Emissions.

1. Take nominal bandwidth as reference channel bandwidth provided that 26 dB emission bandwidth is always larger than nominal bandwidth
2. Measure the power spectral density (which will be used for emissions mask reference) using the following procedure:
 - a) Set the span to encompass the entire 26 dB EBW of the signal.
 - b) Set RBW = same RBW used for 26 dB EBW measurement.
 - c) Set VBW $\geq 3 \times$ RBW
 - d) Number of points in sweep $\geq [2 \times \text{span} / \text{RBW}]$.
 - e) Sweep time = auto.
 - f) Detector = RMS (i.e., power averaging)
 - g) Trace average at least 100 traces in power averaging (rms) mode.
 - h) Use the peak search function on the instrument to find the peak of the spectrum.
3. Using the measuring equipment limit line function, develop the emissions mask based on the following requirements. The emissions power spectral density must be reduced below the peak power spectral density (in dB) as follows:
 - a. Suppressed by 20 dB at 1 MHz outside of the channel edge.
 - b. Suppressed by 28 dB at one channel bandwidth from the channel center.
 - c. Suppressed by 40 dB at one- and one-half times the channel bandwidth from the channel center.
4. Adjust the span to encompass the entire mask as necessary.
5. Clear trace.
6. Trace average at least 100 traces in power averaging (rms) mode.
7. Adjust the reference level as necessary so that the crest of the channel touches the top of the emission mask.

3.4.4 Test Setup

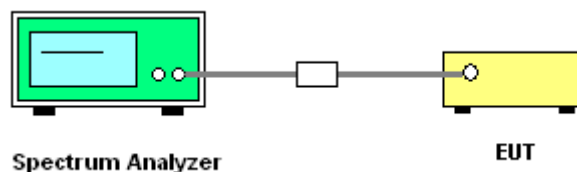



3.4.5 Test Result

Test Engineer :	Jacob Yu, Hank Hsu and Junyu Zhou	Temperature :	17.7~22.5°C
		Relative Humidity :	45.1~61.9%

<SDM Mode>

<Indoor Client>

MIMO <Ant. 9+8(9)>

EUT Mode :	802.11ax HE20 Full RU
------------	-----------------------

Plot on Channel 6435MHz

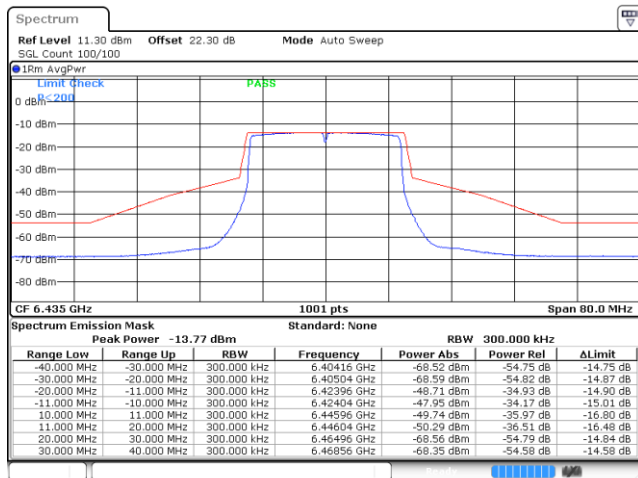

Date: 19 MAY 2022 05:18:39

Plot on Channel 6475MHz

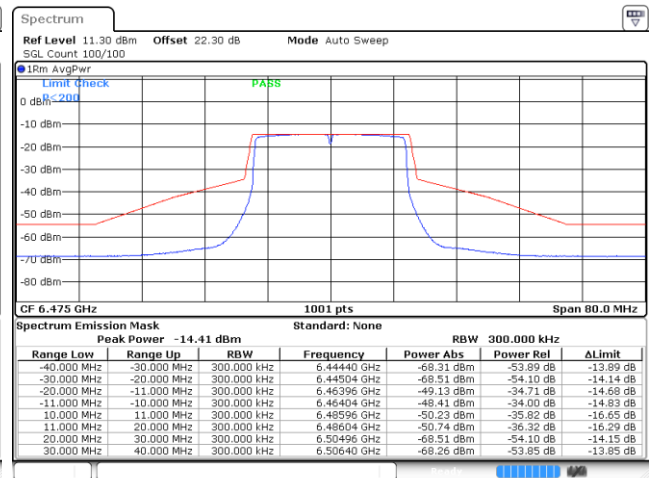

Date: 19 MAY 2022 05:21:40

Plot on Channel 6515MHz

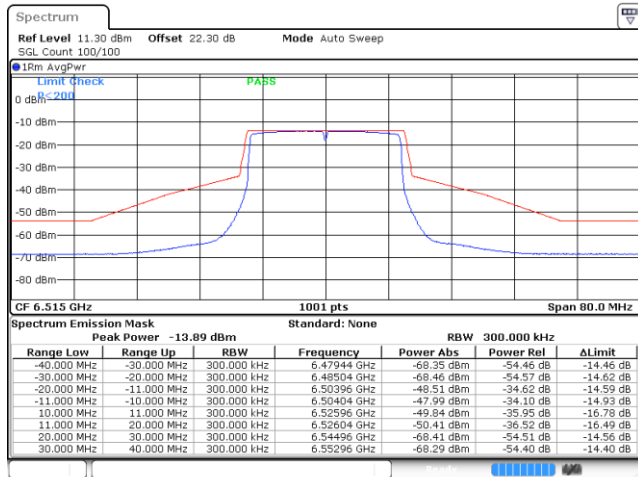

Date: 19 MAY 2022 05:26:03

Plot on Channel 6875MHz

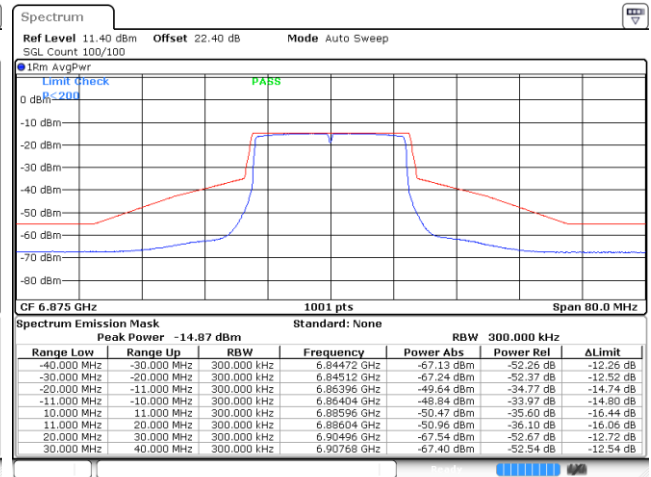

Date: 19 MAY 2022 05:32:27



Plot on Channel 6895MHz

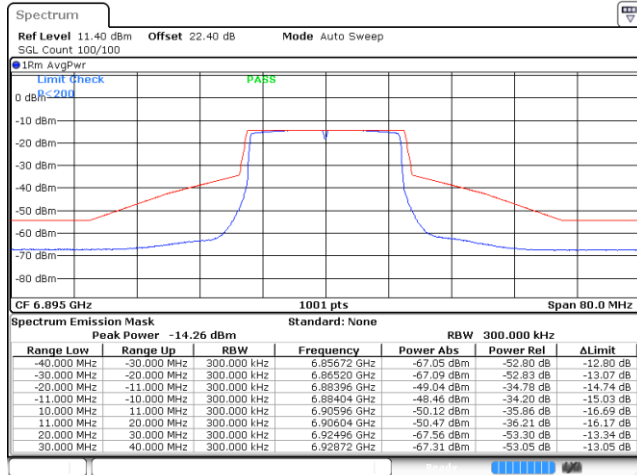

Date: 19 MAY 2022 05:38:02

Plot on Channel 6995MHz

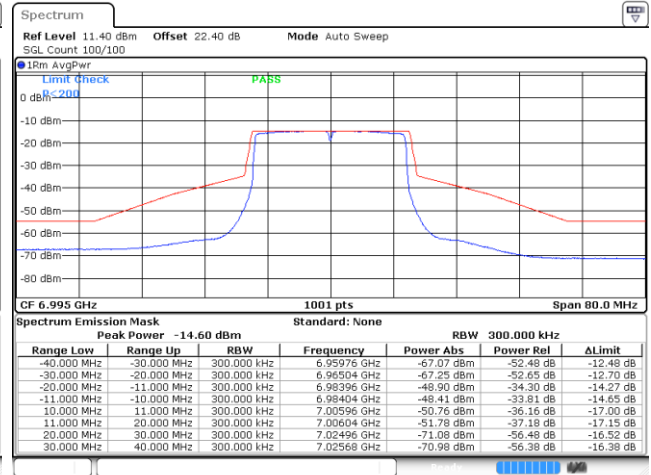

Date: 19 MAY 2022 05:39:31

Plot on Channel 7095MHz

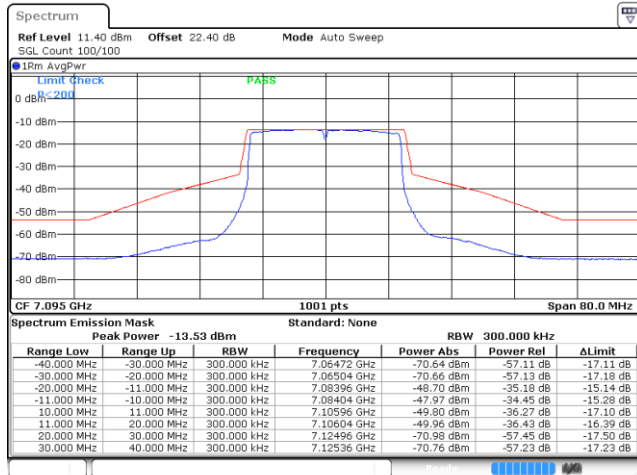

Date: 19 MAY 2022 05:42:32

Plot on Channel 7115MHz

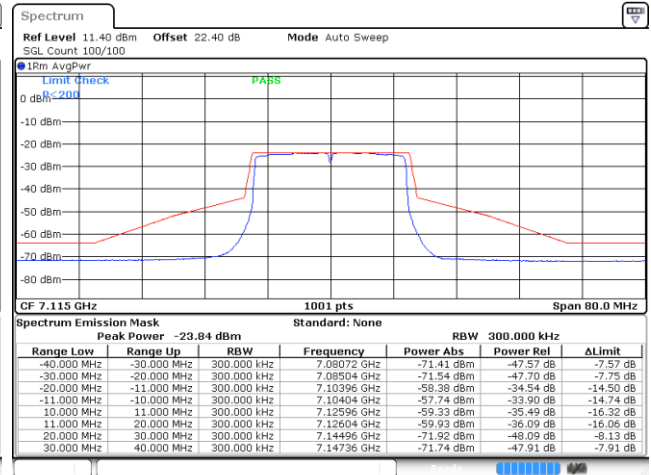

Date: 19 MAY 2022 05:45:51



EUT Mode : 802.11ax HE20 26RU

Plot on Channel 6435MHz

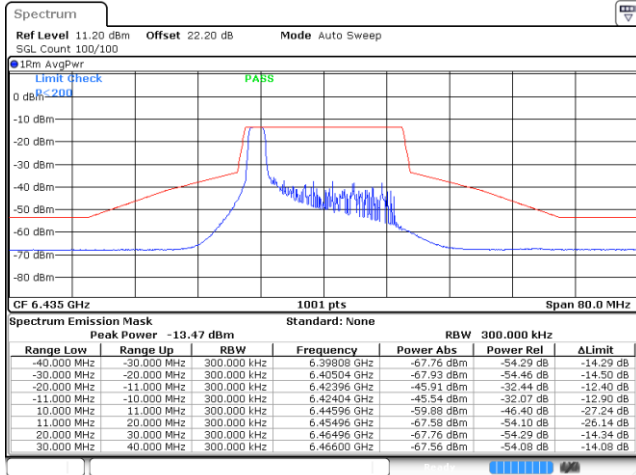

Date: 22 JUN 2022 19:33:46

Plot on Channel 6475MHz

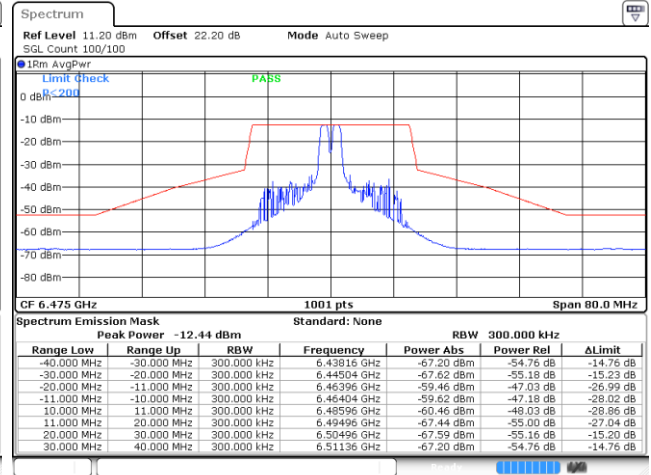

Date: 22 JUN 2022 20:26:13

Plot on Channel 6515MHz

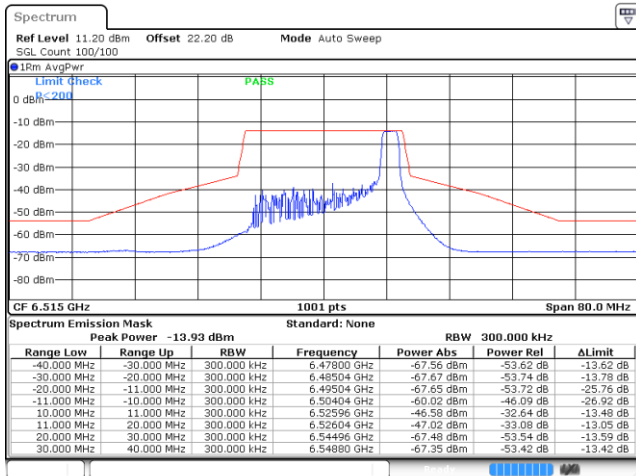

Date: 22 JUN 2022 20:37:08

Plot on Channel 6875MHz

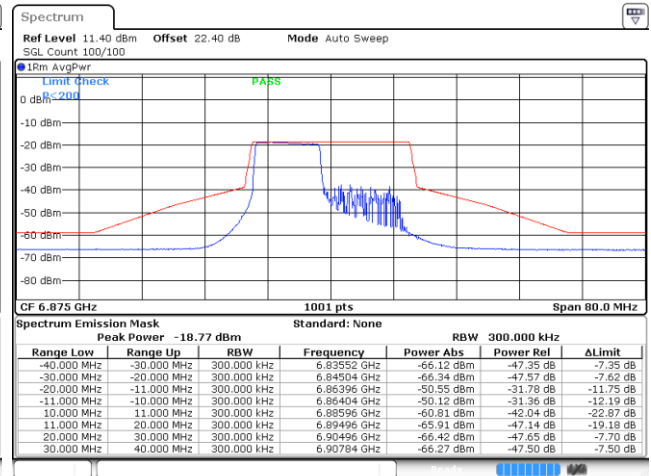

Date: 22 JUN 2022 21:42:53



Plot on Channel 6895MHz

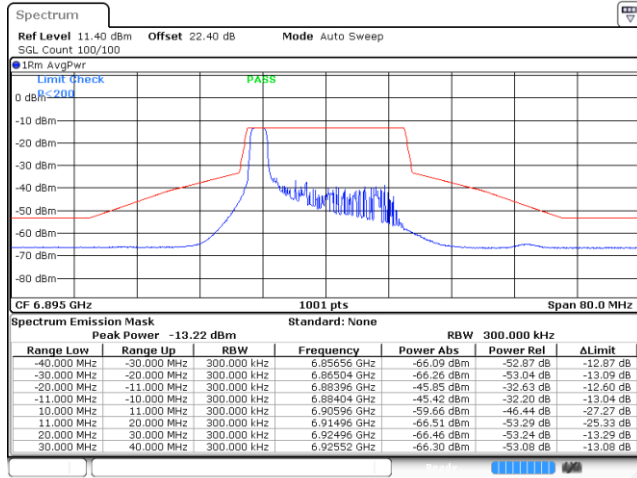

Date: 22 JUN 2022 21:07:35

Plot on Channel 6995MHz

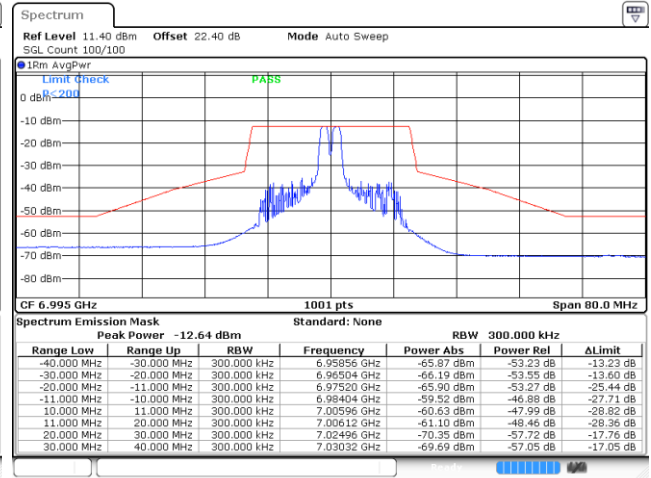

Date: 22 JUN 2022 21:28:16

Plot on Channel 7095MHz

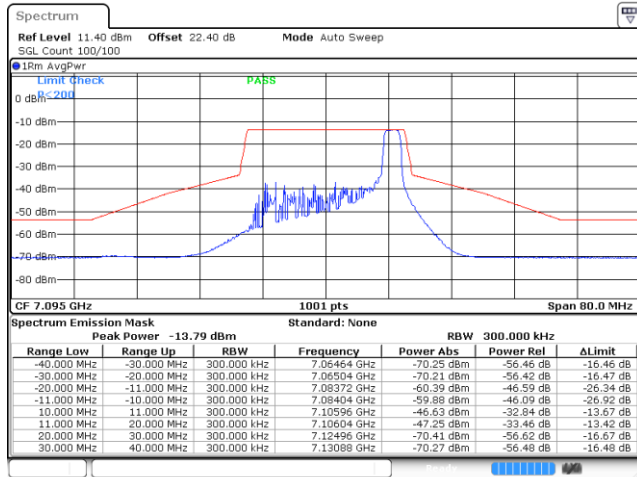

Date: 22 JUN 2022 22:18:50

Plot on Channel 7115MHz

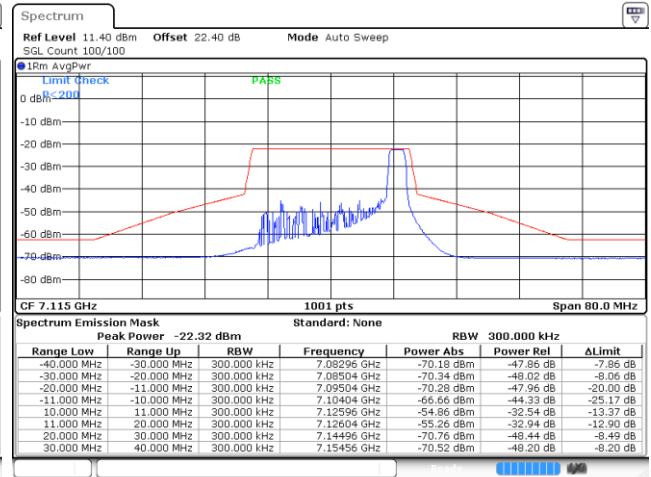

Date: 22 JUN 2022 22:30:23



EUT Mode : 802.11ax HE20 52RU

Plot on Channel 6435MHz

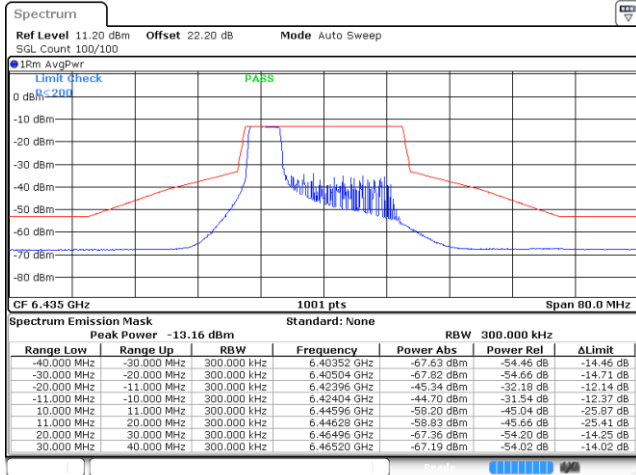

Date: 22 JUN 2022 19:37:09

Plot on Channel 6475MHz

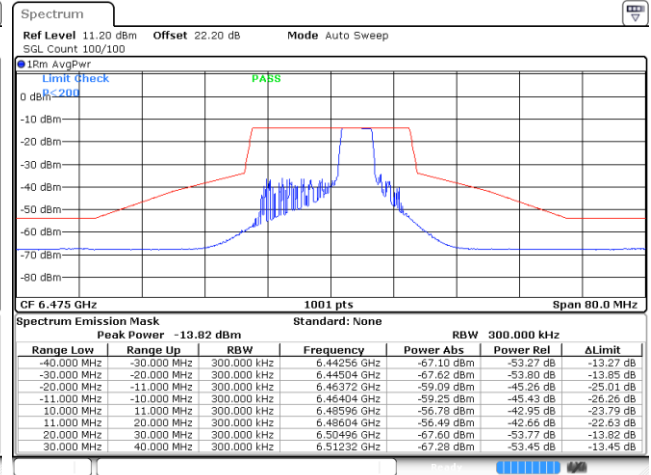

Date: 22 JUN 2022 20:29:45

Plot on Channel 6515MHz

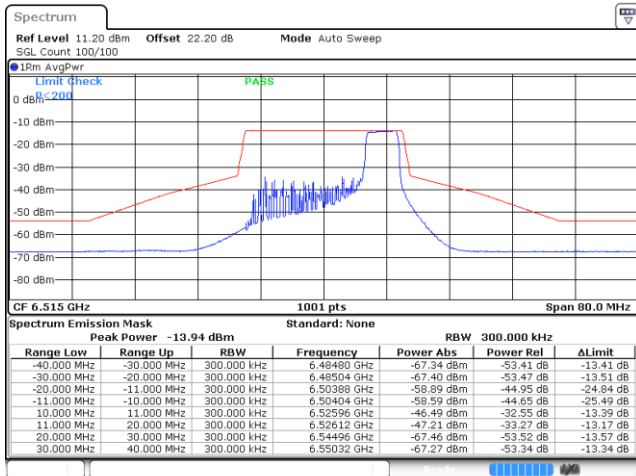

Date: 22 JUN 2022 20:41:26

Plot on Channel 6875MHz

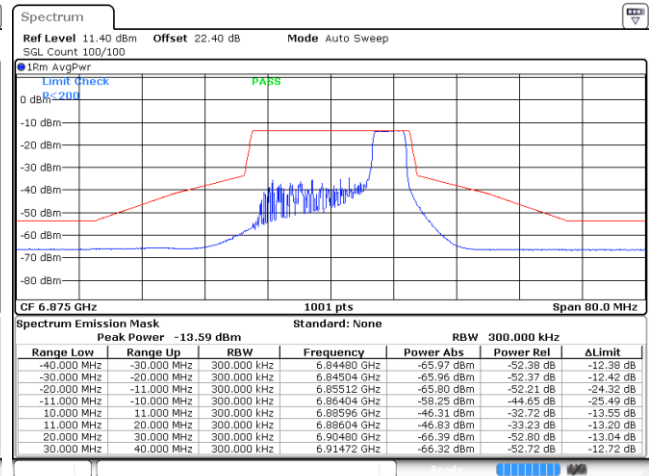

Date: 22 JUN 2022 22:03:14



Plot on Channel 6895MHz

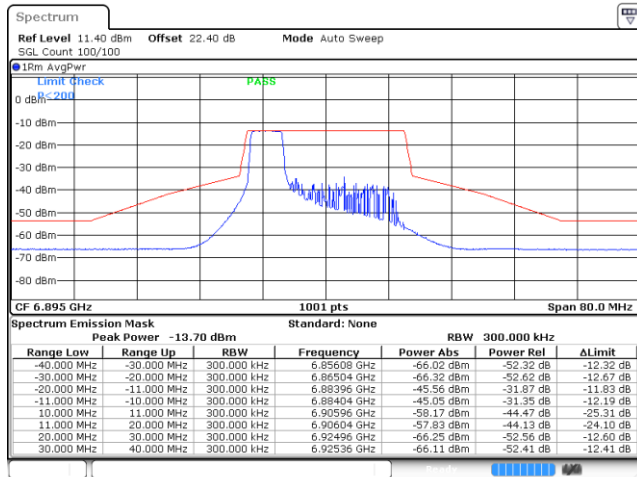

Date: 22 JUN 2022 21:11:25

Plot on Channel 6995MHz

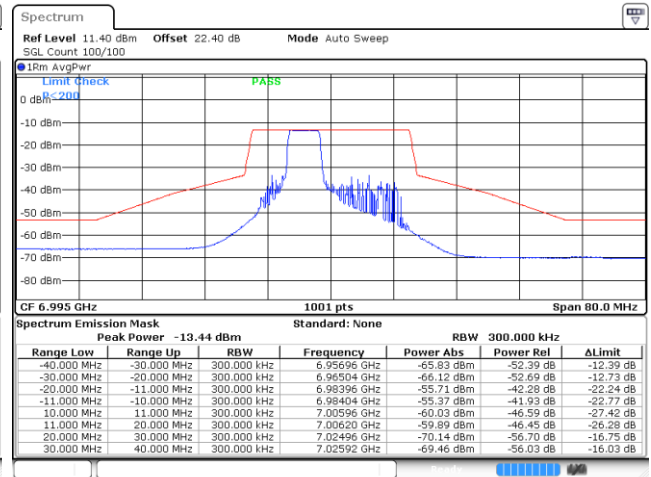

Date: 22 JUN 2022 21:33:14

Plot on Channel 7095MHz

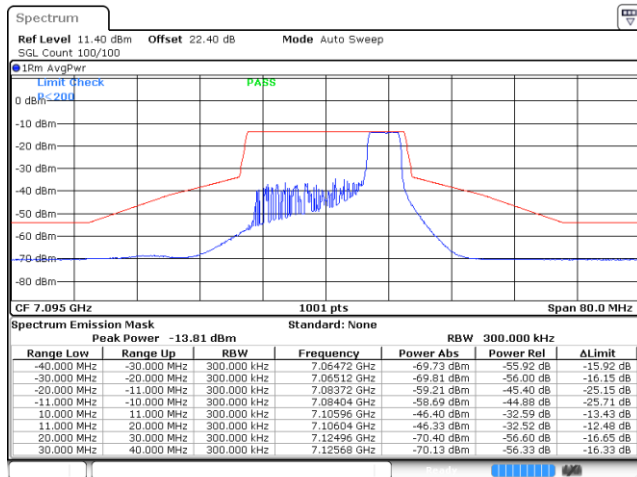

Date: 22 JUN 2022 22:21:43

Plot on Channel 7115MHz

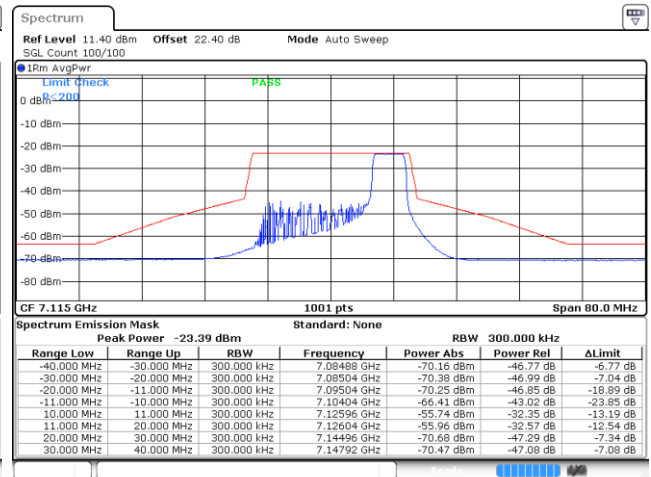

Date: 22 JUN 2022 22:33:48



EUT Mode : 802.11ax HE20 106RU

Plot on Channel 6435MHz

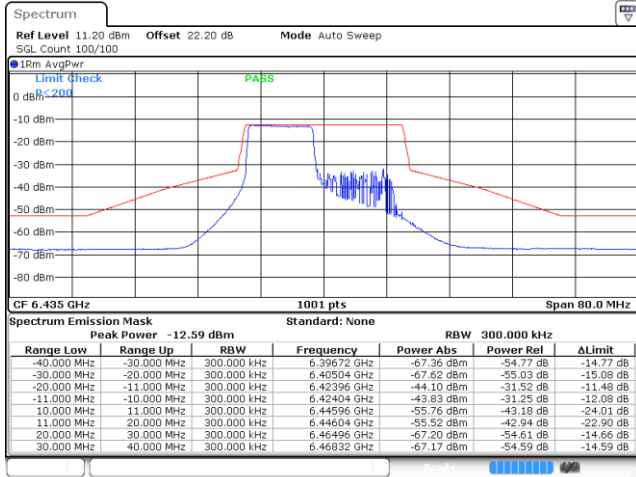

Date: 22 JUN 2022 19:47:40

Plot on Channel 6475MHz

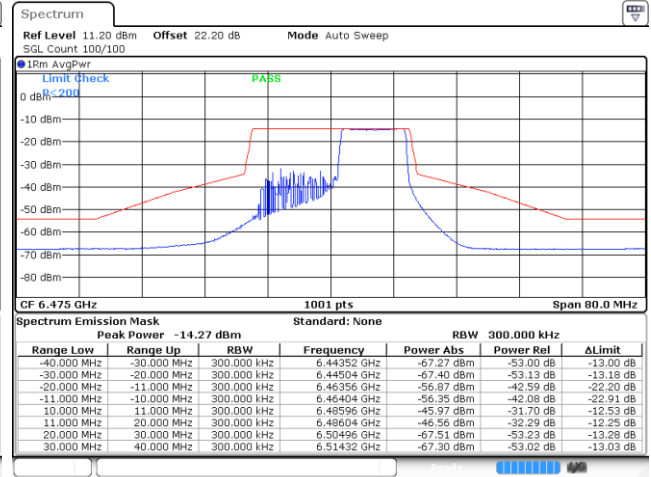

Date: 22 JUN 2022 20:32:55

Plot on Channel 6515MHz

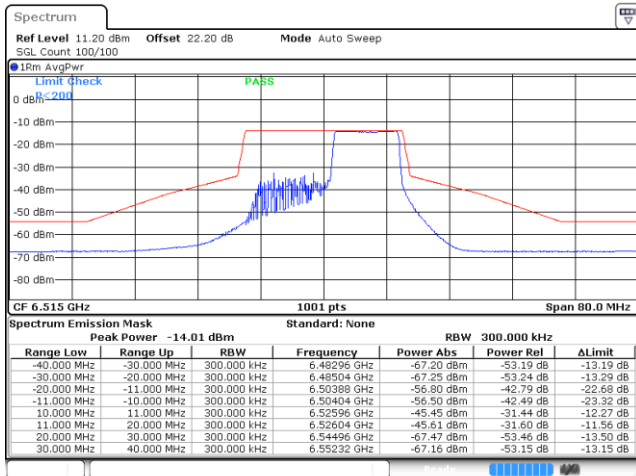

Date: 22 JUN 2022 20:45:59

Plot on Channel 6875MHz

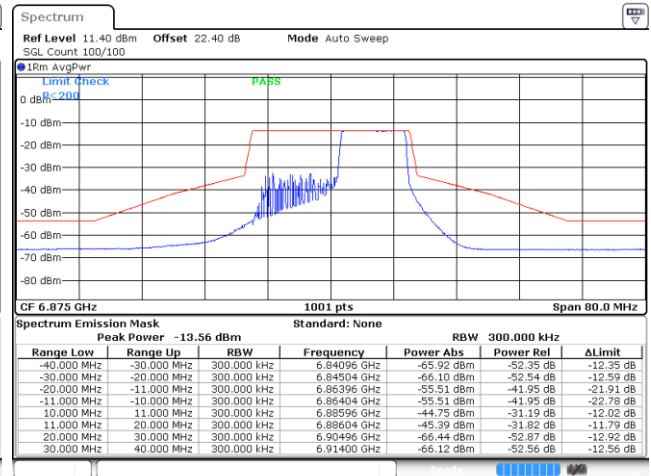

Date: 22 JUN 2022 22:12:42



Plot on Channel 6895MHz

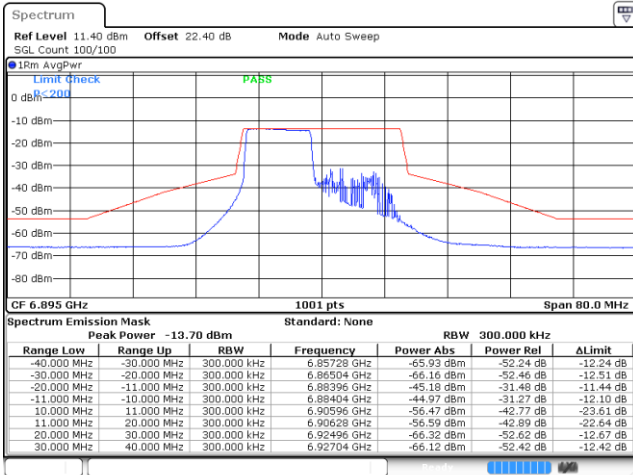

Date: 22 JUN 2022 21:15:59

Plot on Channel 6995MHz

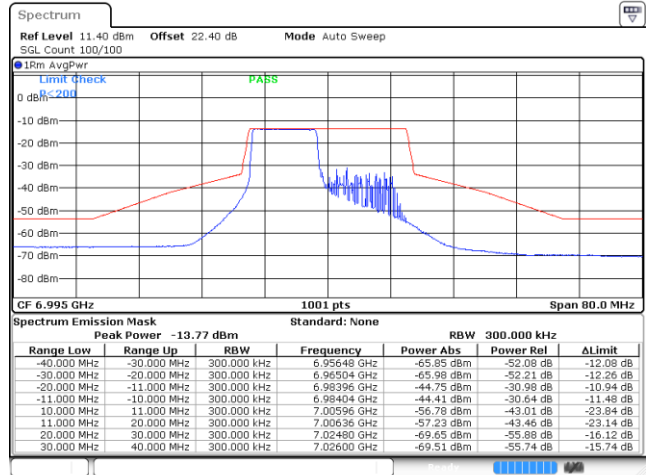

Date: 22 JUN 2022 21:37:20

Plot on Channel 7095MHz

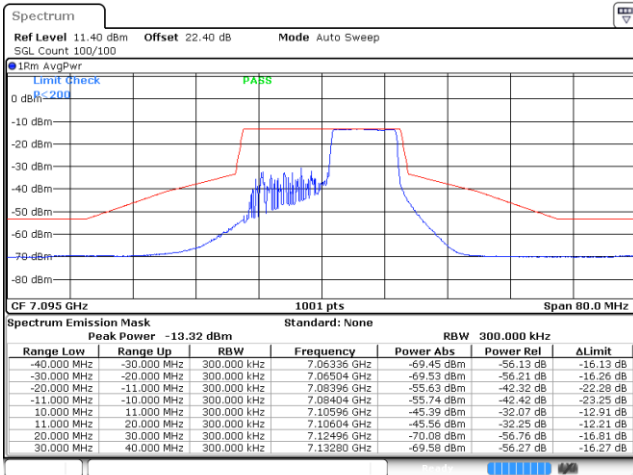

Date: 22 JUN 2022 22:26:24

Plot on Channel 7115MHz

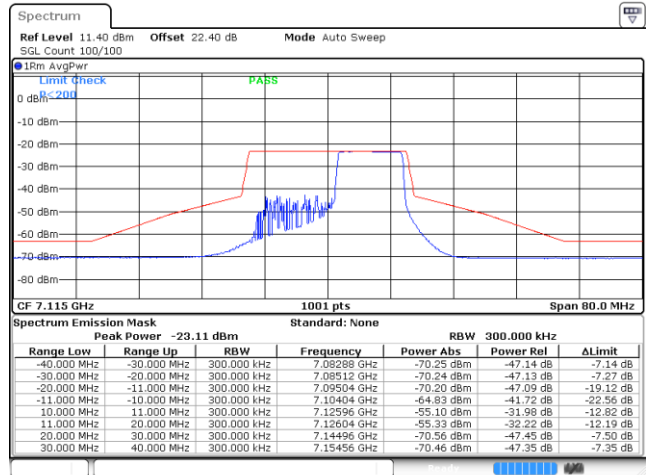

Date: 22 JUN 2022 22:39:38



MIMO <Ant. 9+8(8)>

EUT Mode : 802.11ax HE20 Full RU

Plot on Channel 6435MHz

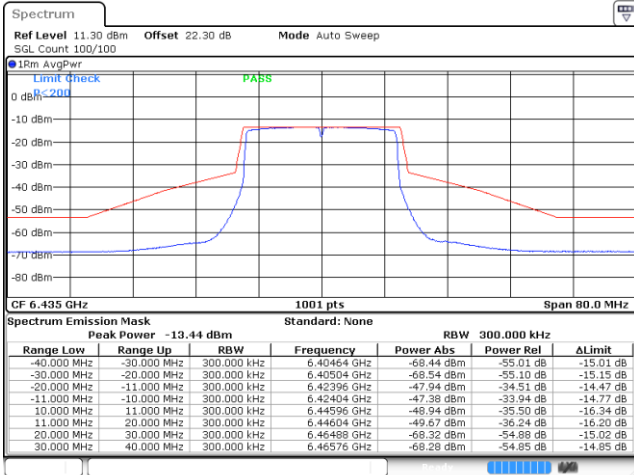

Date: 19 MAY 2022 05:19:45

Plot on Channel 6475MHz

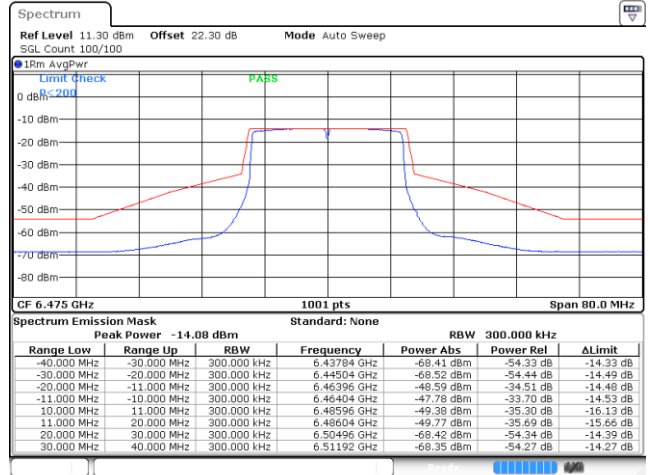

Date: 19 MAY 2022 05:24:18

Plot on Channel 6515MHz

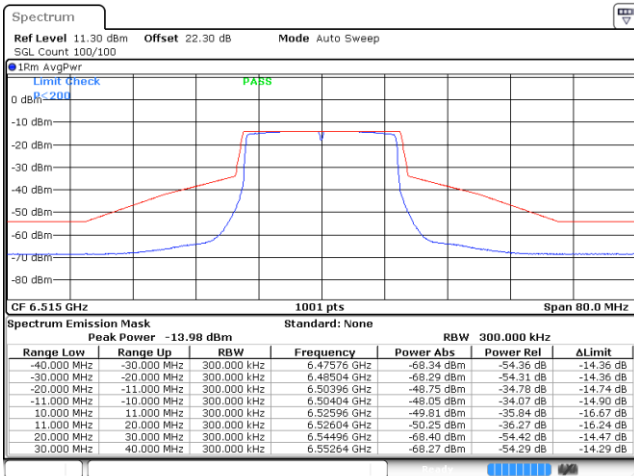

Date: 19 MAY 2022 05:27:57

Plot on Channel 6875MHz

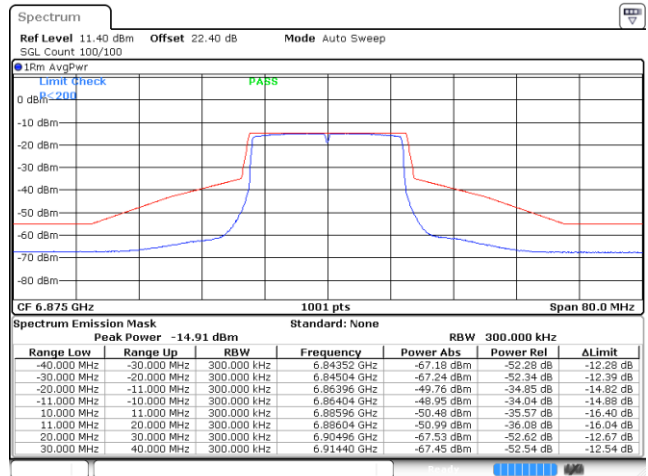

Date: 19 MAY 2022 05:34:25