



**CFCC 47 CFR PART 15 SUBPART C  
ISED RSS-247 ISSUE 2**

**CERTIFICATION TEST REPORT**

*For*

**Speaker**

**MODEL NUMBER: AIR4**

**FCC ID: TQYETONAIR4  
IC: 6233A-ETONAIR4**

**REPORT NUMBER: 4788304691.1-2**

**ISSUE DATE: January 31, 2018**

*Prepared for*

**JAZZ HIPSTER CORPORATION  
2Fd., No.512, Yaun-San Rd. Ghang-Ho City Taiwan**

*Prepared by*

**UL Verification Services (Guangzhou) Co., Ltd, Song Shan Lake Branch  
Room 101, Building 10, Innovation Technology Park,  
Song Shan Lake Hi tech Development Zone, Dongguan, 523808, China  
Tel: +86 769 33817100  
Fax: +86 769 33244054  
Website: [www.ul.com](http://www.ul.com)**

Revision History

<u>Rev.</u>	<u>Issue Date</u>	<u>Revisions</u>	<u>Revised By</u>
--	01/31/2018	Initial Issue	

<b>Summary of Test Results</b>			
<b>Clause</b>	<b>Test Items</b>	<b>FCC/IC Rules</b>	<b>Test Results</b>
1	20dB Bandwidth And 99% Bandwidth	FCC 15.247 (a) (1) RSS-247 Clause 5.1 (a)	Complied
2	Peak Conducted Output Power	FCC 15.247 (b) (1) RSS-247 Clause 5.1 (b)	Complied
3	Carrier Hopping Channel Separation	FCC 15.247 (a) (1) RSS-247 Clause 5.1 (b)	Complied
4	Number of Hopping Frequency	15.247 (a) (1) III RSS-247 Clause 5.1 (d)	Complied
5	Time of Occupancy (Dwell Time)	15.247 (a) (1) III RSS-247 Clause 5.1 (d)	Complied
6	Conducted Bandedge	FCC 15.247 (d) RSS-247 Clause 5.5	Complied
7	Radiated Bandedge and Spurious	FCC 15.247 (d) FCC 15.209 FCC 15.205 RSS-247 Clause 5.5 RSS-GEN Clause 8.9 RSS-GEN Clause 8.10	Complied
8	Conducted Emission Test For AC Power Port	FCC 15.207 RSS-GEN Clause 8.8	Complied
9	Antenna Requirement	FCC 15.203 RSS-GEN Clause 8.3	Complied

## TABLE OF CONTENTS

<b>1. ATTESTATION OF TESCT RESULTS</b> .....	<b>6</b>
<b>2. TEST METHODOLOGY</b> .....	<b>7</b>
<b>3. FACILITIES AND ACCREDITATION</b> .....	<b>7</b>
<b>4. CALIBRATION AND UNCERTAINTY</b> .....	<b>8</b>
4.1. <i>MEASURING INSTRUMENT CALIBRATION</i> .....	8
4.2. <i>MEASUREMENT UNCERTAINTY</i> .....	8
<b>5. EQUIPMENT UNDER TEST</b> .....	<b>9</b>
5.1. <i>DESCRIPTION OF EUT</i> .....	9
5.2. <i>MAXIMUM OUTPUT POWER</i> .....	9
5.3. <i>PACKET TYPE CONFIGURATION</i> .....	9
5.4. <i>CHANNEL LIST</i> .....	10
5.5. <i>TEST CHANNEL CONFIGURATION</i> .....	10
5.6. <i>THE WORSE CASE POWER SETTING PARAMETER</i> .....	10
5.7. <i>DESCRIPTION OF AVAILABLE ANTENNAS</i> .....	11
5.8. <i>WORST-CASE CONFIGURATIONS</i> .....	11
5.9. <i>TEST ENVIRONMENT</i> .....	11
5.10. <i>DESCRIPTION OF TEST SETUP</i> .....	12
5.11. <i>MEASURING INSTRUMENT AND SOFTWARE USED</i> .....	13
<b>6. ANTENNA PORT TEST RESULTS</b> .....	<b>14</b>
6.1. <i>ON TIME AND DUTY CYCLE</i> .....	14
6.2. <i>20 dB BANDWIDTH AND 99% BANDWIDTH</i> .....	16
6.2.1. <i>GFSK MODE</i> .....	17
6.2.2. <i>8DPSK MODE</i> .....	19
6.3. <i>PEAK CONDUCTED OUTPUT POWER</i> .....	21
6.3.1. <i>GFSK MODE</i> .....	22
6.3.2. <i>8DPSK MODE</i> .....	24
6.4. <i>CARRIER HOPPING CHANNEL SEPARATION</i> .....	26
6.4.1. <i>GFSK MODE</i> .....	27
6.4.2. <i>8DPSK MODE</i> .....	28
6.5. <i>NUMBER OF HOPPING FREQUENCY</i> .....	29
6.5.1. <i>GFSK MODE</i> .....	30
6.5.2. <i>8DPSK MODE</i> .....	31
6.6. <i>TIME OF OCCUPANCY (DWELL TIME)</i> .....	32
6.6.1. <i>GFSK MODE</i> .....	33
6.6.2. <i>8DPSK MODE</i> .....	35
6.7. <i>CONDUCTED SPURIOUS EMISSION</i> .....	37
6.7.1. <i>GFSK MODE</i> .....	38

---

6.7.2.	8DPSK MODE .....	42
<b>7.</b>	<b>RADIATED TEST RESULTS.....</b>	<b>46</b>
7.1.	LIMITS AND PROCEDURE.....	46
7.2.	RESTRICTED BANDEDGE.....	51
7.2.1.	GFSK MODE .....	51
7.2.2.	8DPSK MODE .....	55
7.3.	SPURIOUS EMISSIONS (1~18GHz).....	59
7.3.1.	GFSK MODE .....	59
7.3.2.	8DPSK MODE .....	71
7.4.	SPURIOUS EMISSIONS 18G ~ 26GHz.....	83
7.4.1.	GFSK MODE .....	83
7.5.	SPURIOUS EMISSIONS 30M ~ 1 GHz .....	85
7.5.1.	GFSK MODE .....	85
7.6.	SPURIOUS EMISSIONS BELOW 30M.....	87
7.6.1.	GFSK MODE .....	87
<b>8.</b>	<b>AC POWER LINE CONDUCTED EMISSIONS.....</b>	<b>91</b>
8.1.1.	GFSK MODE .....	92
<b>9.</b>	<b>ANTENNA REQUIREMENTS.....</b>	<b>94</b>

# 1. ATTESTATION OF TESCT RESULTS

## Applicant Information

Company Name: JAZZ HIPSTER CORPORATION  
Address: 2Fd., No.512, Yaun-San Rd. Ghang-Ho City Taiwan

## Manufacturer Information

Company Name: ETON Deutschland Electro Acoustic GmbH  
Address: 89231 Neu - Ulm, Pfaffenweg 21, Germany

## EUT Description

Product Name: Speaker  
Brand Name: ETON  
Model Name: AIR4  
Sample ID: 1337271  
Sample Status: Good  
Sample Received date: January 03, 2018  
Date Tested: January 04~January 19, 2018

APPLICABLE STANDARDS	
STANDARD	TEST RESULTS
CFR 47 Part 15 Subpart C	PASS
ISED RSS-247 Issue 2	PASS
ISED RSS-GEN Issue 4	PASS

Tested By:

Checked By:



Miller Ma  
Engineer Project Associate  
Approved By:

Shawn Wen  
Laboratory Leader



Stephen Guo  
Laboratory Manager

## 2. TEST METHODOLOGY

The tests documented in this report were performed in accordance with DA 00-705, KDB414788 D01 Radiated Test Site v01, ANSI C63.10-2013, FCC CFR 47 Part 2, FCC CFR 47 Part 15, RSS-GEN Issue 4, and RSS-247 Issue 2.

## 3. FACILITIES AND ACCREDITATION

Accreditation Certificate	<p><b>A2LA (Certificate No.: 4102.01)</b> UL Verification Services (Guangzhou) Co., Ltd. Song Shan Lake Branch. has been assessed and proved to be in compliance with A2LA.</p> <p><b>IAS (Lab Code: TL-702)</b> UL Verification Services (Guangzhou) Co., Ltd. Song Shan Lake Branch. has demonstrated compliance with ISO/IEC Standard 17025:2005, General requirements for the competence of testing and calibration laboratories</p> <p><b>FCC (FCC Designation No.: CN1187)</b> UL Verification Services (Guangzhou) Co., Ltd. Song Shan Lake Branch. Has been recognized to perform compliance testing on equipment subject to the Commission's Declaration of Conformity (DoC) and Certification rules</p> <p><b>IC(Company No.: 21320)</b> UL Verification Services (Guangzhou) Co., Ltd. Song Shan Lake Branch. has been registered and fully described in a report filed with Industry Canada. The Company Number is 21320.</p> <p><b>VCCI (Registration No.: G-20019, R-20004, C-20012 and T-20011)</b> UL Verification Services (Guangzhou) Co., Ltd. Song Shan Lake Branch. has been assessed and proved to be in compliance with VCCI, the Membership No. is 3793. Facility Name: Chamber D, the VCCI registration No. is G-20019 and R-20004 Shielding Room B , the VCCI registration No. is C-20012 and T-20011</p>
---------------------------	---

Note 1: All tests measurement facilities use to collect the measurement data are located at Building 10, Innovation Technology Park, Song Shan Lake Hi tech Development Zone, Dongguan, 523808, China

Note 2: The test anechoic chamber in UL Verification Services (Guangzhou) Co., Ltd. Song Shan Lake Branch had been calibrated and compared to the open field sites and the test anechoic chamber is shown to be equivalent to or worst case from the open field site.

Note 3: For below 30MHz, lab had performed measurements at test anechoic chamber and comparing to measurements obtained on an open field site. And these measurements below 30MHz had been correlated to measurements performed on an OATS.

## 4. CALIBRATION AND UNCERTAINTY

### 4.1. MEASURING INSTRUMENT CALIBRATION

The measuring equipment utilized to perform the tests documented in this report has been calibrated in accordance with the manufacturer's recommendations, and is traceable to recognized national standards.

### 4.2. MEASUREMENT UNCERTAINTY

Where relevant, the following measurement uncertainty levels have been estimated for tests performed on the apparatus:

Test Item	Uncertainty
Uncertainty for Conduction emission test	2.90dB
Uncertainty for Radiation Emission test(include Fundamental emission) (9KHz-30MHz)	2.2dB
Uncertainty for Radiation Emission test(include Fundamental emission) (30MHz-1GHz)	4.52dB
Uncertainty for Radiation Emission test (1GHz to 26GHz)( include Fundamental emission)	5.04dB(1-6GHz)
	5.30dB (6GHz-18Gz)
	5.23dB (18GHz-26Gz)
Note: This uncertainty represents an expanded uncertainty expressed at approximately the 95% confidence level using a coverage factor of k=2.	

## 5. EQUIPMENT UNDER TEST

### 5.1. DESCRIPTION OF EUT

Equipment	Speaker		
Model Name	AIR4		
Product Description (Bluetooth)	Operation Frequency	2402 MHz ~ 2480 MHz	
	Modulation Type	Data Rate	
	GFSK	1Mbps	
	π/4-DQPSK	2Mbps	
	8DPSK	3Mbps	
Power Supply	AC120V/60Hz		
Bluetooth Version	Bluetooth V4.1 LE+EDR		
Hardware Version	V1.0		
Software Version	V1.0		

### 5.2. MAXIMUM OUTPUT POWER

Bluetooth Mode	Frequency (MHz)	Channel Number	Max Output Power (dBm)	EIRP (dBm)
GFSK	2402-2480	0-78[79]	7.067	12.037
8DPSK	2402-2480	0-78[79]	3.610	8.580

### 5.3. PACKET TYPE CONFIGURATION

Test Mode	Packet Type	Setting(Packet Length)
GFSK	DH1	27
	DH3	183
	DH5	339
π/4-DQPSK	2-DH1	54
	2-DH3	367
	2-DH5	679
8DPSK	3-DH1	83
	3-DH3	552
	3-DH5	1021

### 5.4. CHANNEL LIST

Channel	Frequency (MHz)	Channel	Frequency (MHz)	Channel	Frequency (MHz)	Channel	Frequency (MHz)
00	2402	20	2422	40	2442	60	2462
01	2403	21	2423	41	2443	61	2463
02	2404	22	2424	42	2444	62	2464
03	2405	23	2425	43	2445	63	2465
04	2406	24	2426	44	2446	64	2466
05	2407	25	2427	45	2447	65	2467
06	2408	26	2428	46	2448	66	2468
07	2409	27	2429	47	2449	67	2469
08	2410	28	2430	48	2450	68	2470
09	2411	29	2431	49	2451	69	2471
10	2412	30	2432	50	2452	70	2472
11	2413	31	2433	51	2453	71	2473
12	2414	32	2434	52	2454	72	2474
13	2415	33	2435	53	2455	73	2475
14	2416	34	2436	54	2456	74	2476
15	2417	35	2437	55	2457	75	2477
16	2418	36	2438	56	2458	76	2478
17	2419	37	2439	57	2459	77	2479
18	2420	38	2440	58	2460	78	2480
19	2421	39	2441	59	2461		

### 5.5. TEST CHANNEL CONFIGURATION

Test Mode	Test Channel Number	Test Channel
GFSK	CH 00, CH 39, CH 78	Low, Middle, High
8DPSK	CH 00, CH 39, CH 78	Low, Middle, High

### 5.6. THE WORSE CASE POWER SETTING PARAMETER

The Worst Case Power Setting Parameter under 2400 ~ 2483.5MHz Band				
Test Software		DutApi_w8887_BrdigeEth		
Modulation Type	Transmit Antenna Number	Test Channel		
		CH 00	CH 39	CH 78
GFSK	1	8	8	8
8DPSK	1	4	4	4
GFSK	2	8	8	8
8DPSK	2	4	4	4

### 5.7. DESCRIPTION OF AVAILABLE ANTENNAS

Ant.	Frequency (MHz)	Antenna Type	Antenna Gain (dBi)
1	2402-2480	FPC+CABLE	4.97
2	2402-2480	FPC+CABLE	4.23

Test Mode	Transmit and Receive Mode	Description
GFSK	1TX, 1RX	Antenna 1 or Antenna 2 can be used as transmitting/receiving antenna.
8DPSK	1TX, 1RX	Antenna 1 or Antenna 2 can be used as transmitting/receiving antenna.

Note1: Equipment with 2 diversity antennas but only 1 antenna active at any moment in time.  
 Note2: The circuit before the two difference antenna are the same, the two antenna types are the same and the gain of antenna 1 is larger, antenna 1 was found to the worst case and recorded.

### 5.8. WORST-CASE CONFIGURATIONS

Bluetooth Mode	Modulation Technology	Modulation Type	Data Rate (Mbps)
BR	FHSS	GFSK	1Mbit/s
EDR	FHSS	8DPSK	3Mbit/s

Note: Pre-Scan has been conducted to determine the worst-case mode from all possible combinations between available modulations, data rates.

### 5.9. TEST ENVIRONMENT

Environment Parameter	Selected Values During Tests	
Relative Humidity	55 ~ 65%	
Atmospheric Pressure:	1025Pa	
Temperature	TN	23 ~ 28 °C
Voltage :	VL	N/A
	VN	AC 120V 60Hz
	VH	N/A

Note: VL= Lower Extreme Test Voltage  
 VN= Nominal Voltage.  
 VH= Upper Extreme Test Voltage  
 TN= Normal Temperature

## 5.10. DESCRIPTION OF TEST SETUP

### SUPPORT EQUIPMENT

Item	Equipment	Brand Name	Model Name	FCC ID
1	Table PC	ThinkPad	T410	N/A
2	Router	ASUS	RT-AC68U	N/A
3	USB to TTL Serial Cable	N/A	N/A	N/A
4	USB 2.0 Ethernet Network Adapter	UGREEN	20254	N/A

### I/O CABLES

Cable No	Port	Connector Type	Cable Type	Cable Length(m)	Remarks
C-1	RJ45	RJ45	RJ45	1.5	N/A
C-2	RJ45	RJ45	RJ45	1.5	N/A
C-3	USB	USB	USB	1.5	N/A

### ACCESSORY

Item	Accessory	Brand Name	Model Name	Description
1	Remote controller	ETON	N/A	N/A

### TEST SETUP

The EUT can work in an engineer mode with a software through a PC.

### SETUP DIAGRAM FOR TEST

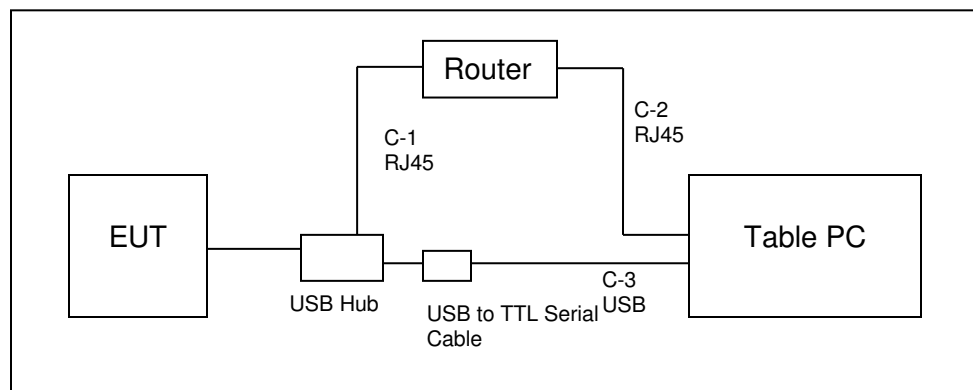

**5.11. MEASURING INSTRUMENT AND SOFTWARE USED**

Conducted Emissions						
Used	Equipment	Manufacturer	Model No.	Serial No.	Last Cal.	Next Cal.
<input checked="" type="checkbox"/>	EMI Test Receiver	R&S	ESR3	101961	Dec.12, 2017	Dec.12, 2018
<input checked="" type="checkbox"/>	Two-Line V-Network	R&S	ENV216	101983	Jan.16, 2018	Jan.16, 2019
<input checked="" type="checkbox"/>	Artificial Mains Networks	Schwarzbeck	NSLK 8126	8126465	Dec.12, 2017	Dec.12, 2018
Software						
Used	Description	Manufacturer	Name	Version		
<input checked="" type="checkbox"/>	Test Software for Conducted disturbance	UL	Antenna port	Ver. 7.2		
Radiated Emissions						
Used	Equipment	Manufacturer	Model No.	Serial No.	Last Cal.	Next Cal.
<input checked="" type="checkbox"/>	MXE EMI Receiver	KESIGHT	N9038A	MY56400036	Dec.12, 2017	Dec.12, 2018
<input checked="" type="checkbox"/>	Hybrid Log Periodic Antenna	TDK	HLP-3003C	130960	Jan.09, 2016	Jan.09, 2019
<input checked="" type="checkbox"/>	Preamplifier	HP	8447D	2944A09099	Dec. 12, 2017	Dec.12, 2018
<input checked="" type="checkbox"/>	EMI Measurement Receiver	R&S	ESR26	101377	Dec. 12, 2017	Dec.12, 2018
<input checked="" type="checkbox"/>	Horn Antenna	TDK	HRN-0118	130939	Jan. 09, 2016	Jan. 09, 2019
<input checked="" type="checkbox"/>	High Gain Horn Antenna	Schwarzbeck	BBHA-9170	691	Jan.06, 2016	Jan.06, 2019
<input checked="" type="checkbox"/>	Preamplifier	TDK	PA-02-0118	TRS-305-00066	Dec.12, 2017	Dec.12, 2018
<input checked="" type="checkbox"/>	Preamplifier	TDK	PA-02-2	TRS-307-00003	Dec.12, 2017	Dec.12, 2018
<input checked="" type="checkbox"/>	Loop antenna	Schwarzbeck	1519B	00008	Mar. 26, 2016	Mar. 26, 2019
<input checked="" type="checkbox"/>	Band Reject Filter	Wainwright	WRCJV8-2350-2400-2483.5-2533.5-40SS	4	Dec. 12, 2017	Dec.12, 2018
Software						
Used	Description	Manufacturer	Name	Version		
<input checked="" type="checkbox"/>	Test Software for Radiated disturbance	Farad	EZ-EMC	Ver. UL-3A1		
Other instruments						
Used	Equipment	Manufacturer	Model No.	Serial No.	Last Cal.	Next Cal.
<input checked="" type="checkbox"/>	Spectrum Analyzer	Keysight	N9030A	MY55410512	Dec. 12, 2017	Dec.12, 2018
<input checked="" type="checkbox"/>	Power Meter	Keysight	N9031A	MY55416024	Feb. 13, 2017	Dec.12, 2018
<input checked="" type="checkbox"/>	Power Sensor	Keysight	N9323A	MY55440013	Feb. 13, 2017	Dec.12, 2018

## 6. ANTENNA PORT TEST RESULTS

### 6.1. ON TIME AND DUTY CYCLE

#### LIMITS

None; for reporting purposes only

#### PROCEDURE

KDB 558074 Zero-Span Spectrum Analyzer Method

#### TEST SETUP

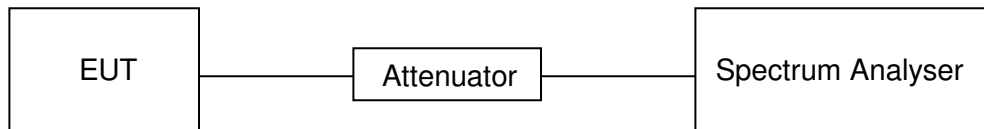

#### RESULTS

Mode	On Time (msec)	Period (msec)	Duty Cycle x (Linear)	Duty Cycle (%)	Duty Cycle Correction Factor (db)	1/T Minimum VBW (KHz)
GFSK	2.860	3.760	0.761	76	1.19	0.35
8DPSK	2.880	3.760	0.766	77	1.16	0.35

Note: Duty Cycle Correction Factor= $10\log(1/x)$ .  
Where: x is Duty Cycle(Linear)  
Where: T is On Time (transmit duration)  
The duty cycle of antenna 1 and antenna 2 is the same.

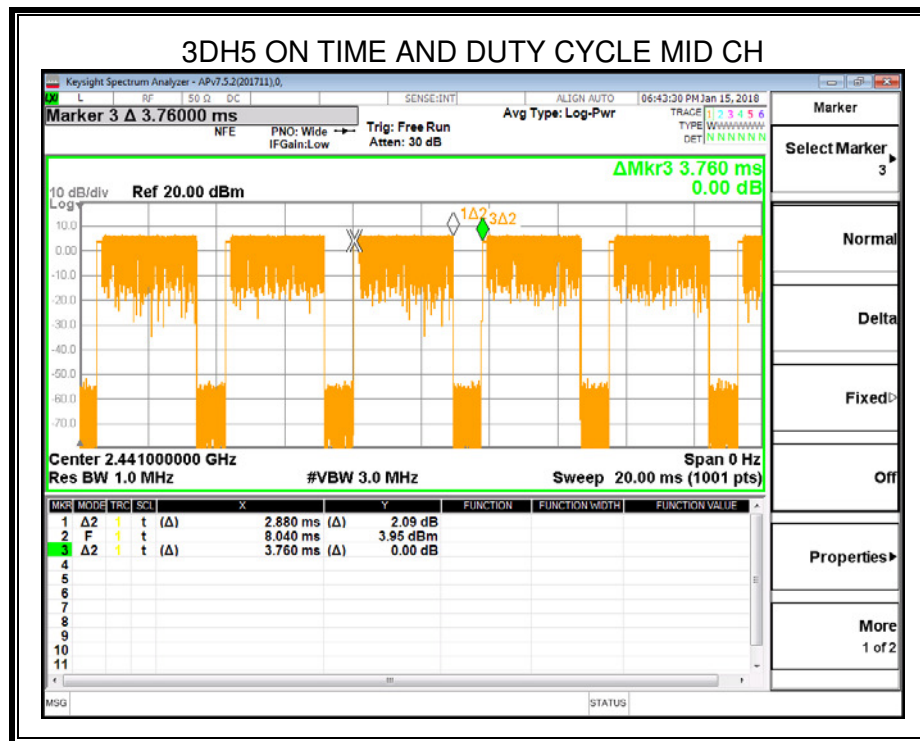
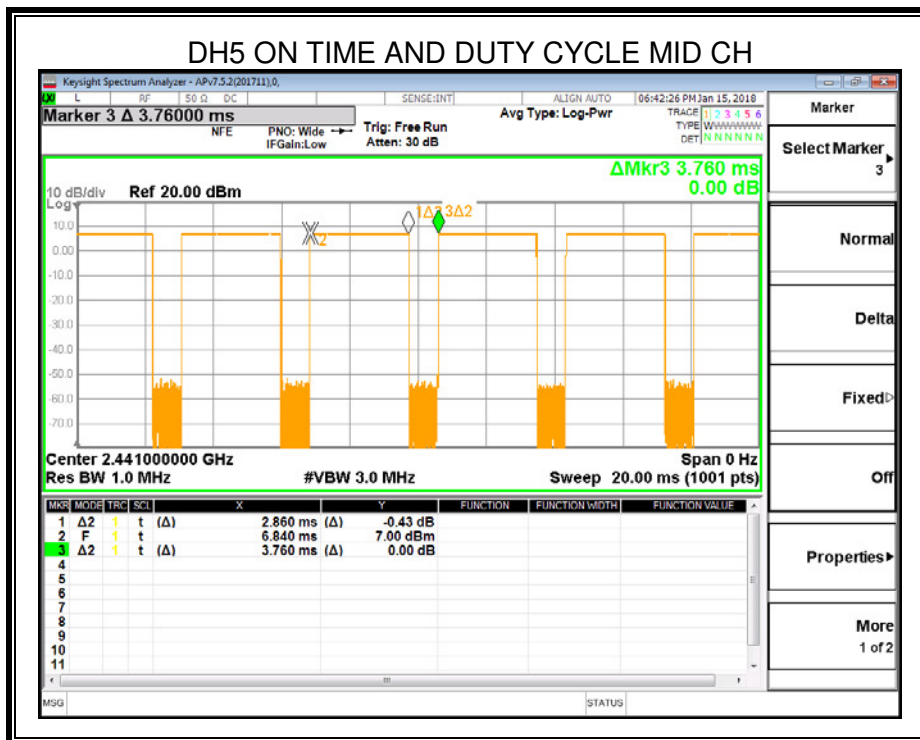

## 6.2. 20 dB BANDWIDTH AND 99% BANDWIDTH

### LIMITS

FCC Part15 (15.247) Subpart C RSS-247 ISSUE 2			
Section	Test Item	Limit	Frequency Range (MHz)
FCC 15.247 (a) (1) RSS-247 Clause 5.1 (a)	20dB Bandwidth	500KHz	2400-2483.5
RSS-Gen Clause 6.6	99% Bandwidth	N/A	2400-2483.5

### TEST PROCEDURE

Connect the UUT to the spectrum analyser and use the following settings:

Center Frequency	The centre frequency of the channel under test
Detector	Peak
RBW	For 20dB Bandwidth: 1% of the 20 dB bandwidth For 99% Bandwidth: 1% to 5% of the occupied bandwidth
VBW	For 20dB Bandwidth: $\geq$ RBW For 99% Bandwidth: approximately $3 \times$ RBW
Span	approximately 2 to 3 times the 20 dB bandwidth
Trace	Max hold
Sweep	Auto couple

Allow the trace to stabilize and measure the maximum width of the emission that is constrained by the frequencies associated with the two outermost amplitude points (upper and lower frequencies) that are attenuated by 20 dB relative to the maximum level measured in the fundamental emission.

### TEST SETUP

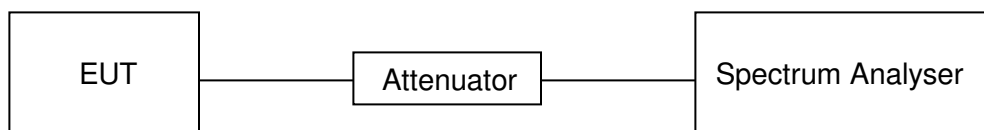

**RESULTS**

**ANTENNA1**

**6.2.1. GFSK MODE**

Channel	Frequency (MHz)	20dB bandwidth (MHz)	99% bandwidth (MHz)	Result
Low	2402	0.930	0.851	PASS
Middle	2441	0.932	0.849	PASS
High	2480	0.929	0.842	PASS

**Test Graph**

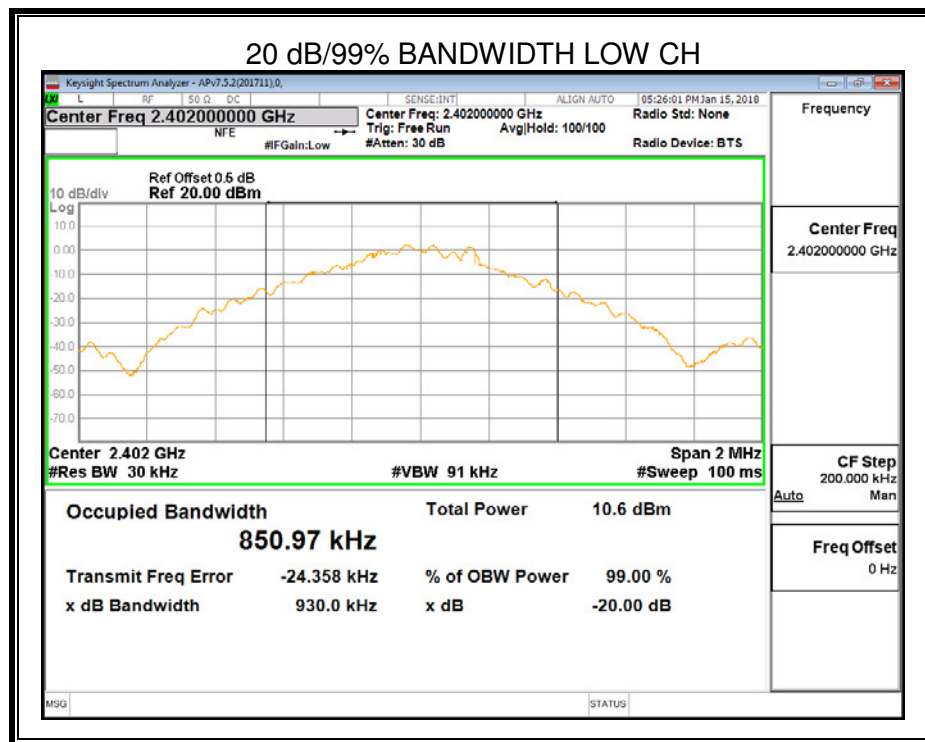

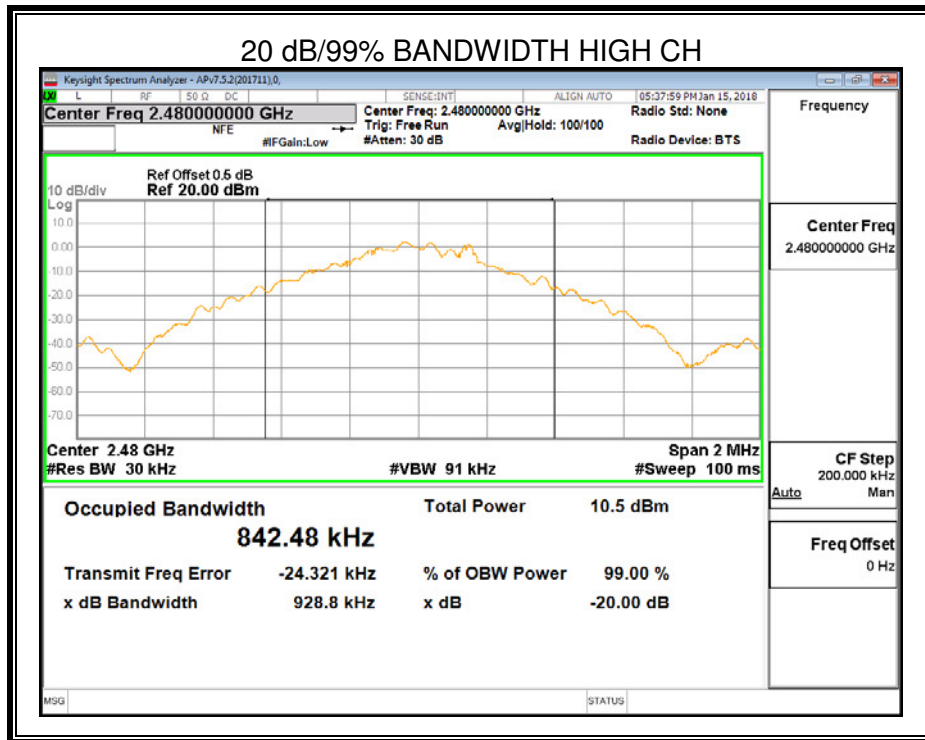
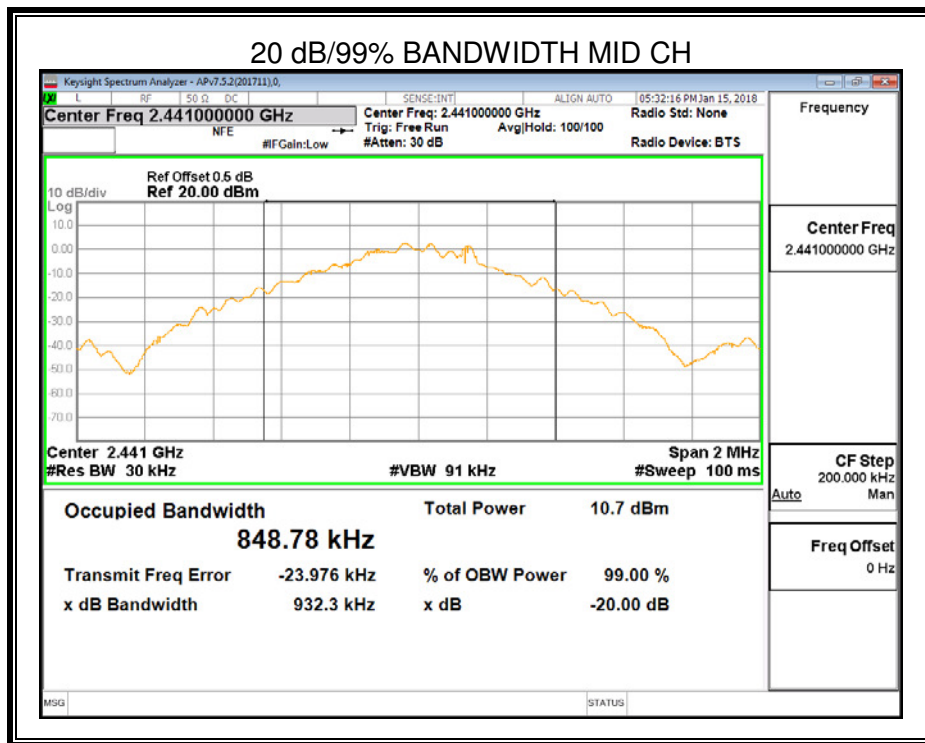

**6.2.2. 8DPSK MODE**

Channel	Frequency (MHz)	20dB bandwidth (MHz)	99% bandwidth (MHz)	Result
Low	2402	1.281	1.178	Pass
Middle	2441	1.278	1.174	Pass
High	2480	1.282	1.175	Pass

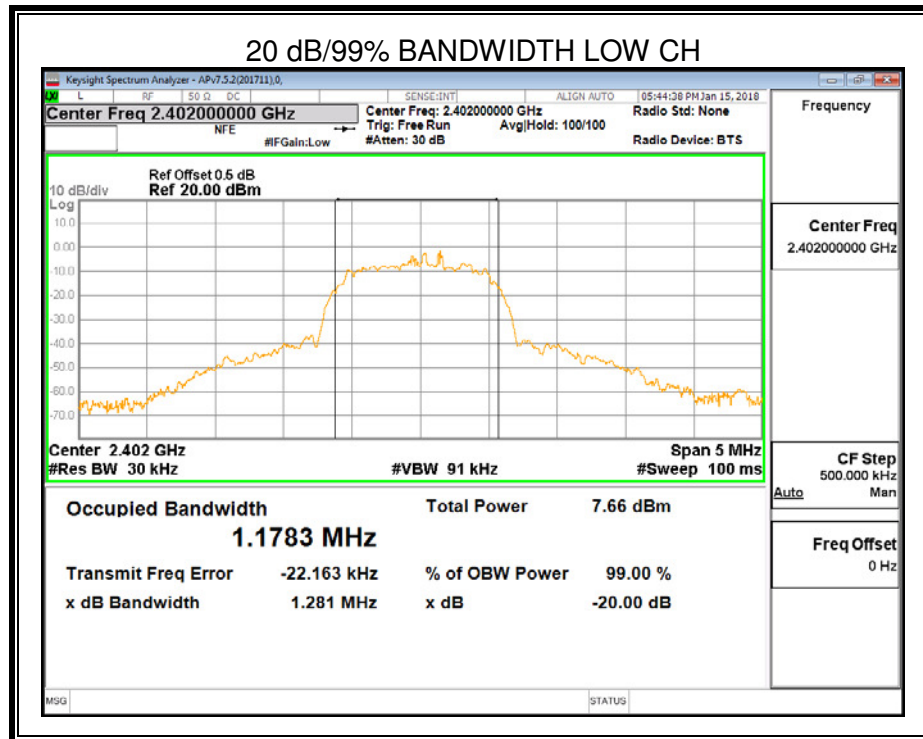

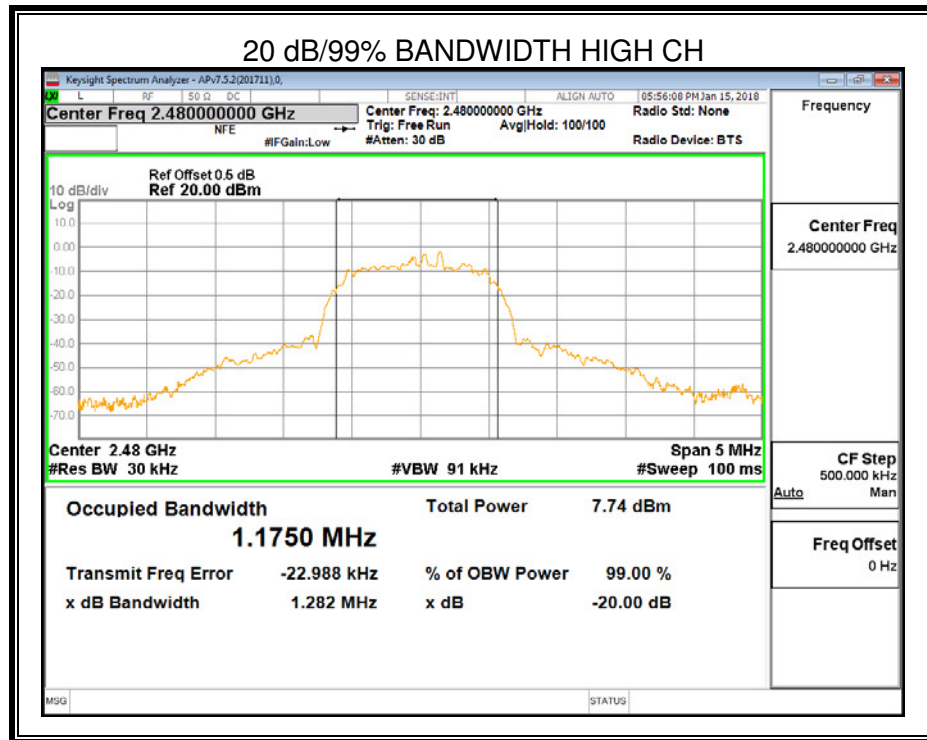
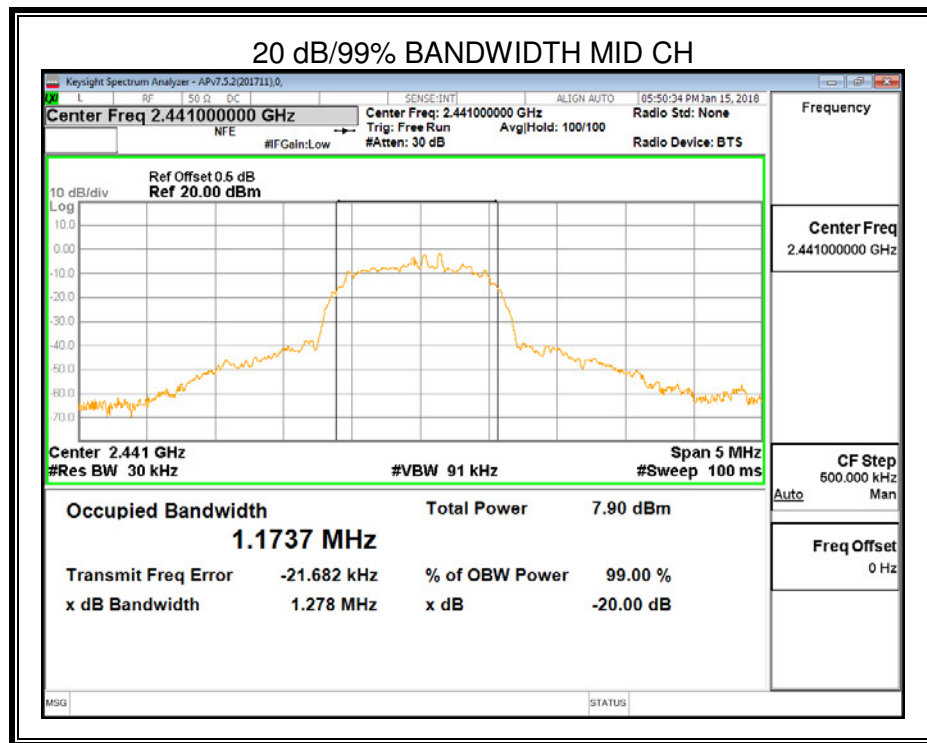

### 6.3. PEAK CONDUCTED OUTPUT POWER

#### LIMITS

FCC Part15 (15.247) , Subpart C RSS-247 ISSUE 2			
Section	Test Item	Limit	Frequency Range (MHz)
FCC 15.247 (b) (1) RSS-247 Clause 5.4 (b)	Peak Conducted Output Power	1 watt or 30dBm	2400-2483.5

#### TEST PROCEDURE

Connect the UUT to the spectrum analyser and use the following settings:

Center Frequency	The centre frequency of the channel under test
Detector	Peak
RBW	≥ 20 dB bandwidth
VBW	≥RBW
Span	Approximately five times the 20 dB bandwidth
Trace	Max hold
Sweep time	Auto couple

Allow trace to fully stabilize and use peak marker function to determine the peak amplitude level.

#### TEST SETUP

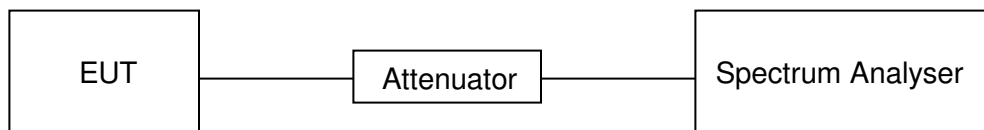

**RESULTS**

**ANTENNA1**

**6.3.1. GFSK MODE**

Channel	Frequency	Maximum Conducted Output Power(PK)	EIRP	Result
	(MHz)	(dBm)	(dBm)	
Low	2402	6.970	11.940	Pass
Middle	2441	7.067	12.037	Pass
High	2480	6.871	11.841	Pass

Note: EIRP= Maximum Conducted Output Power + Antenna Gain

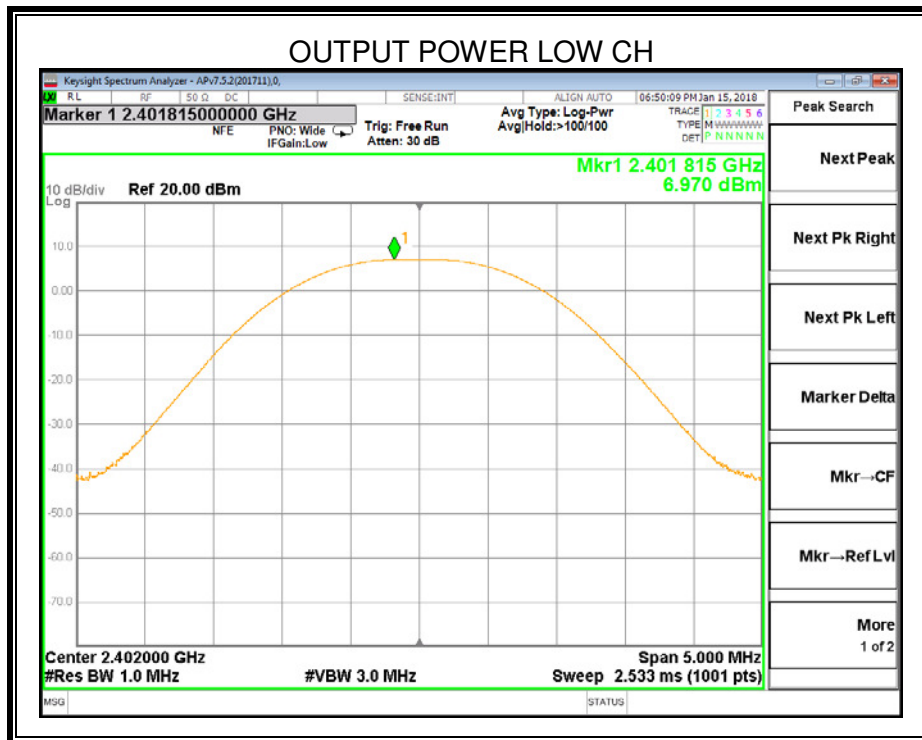

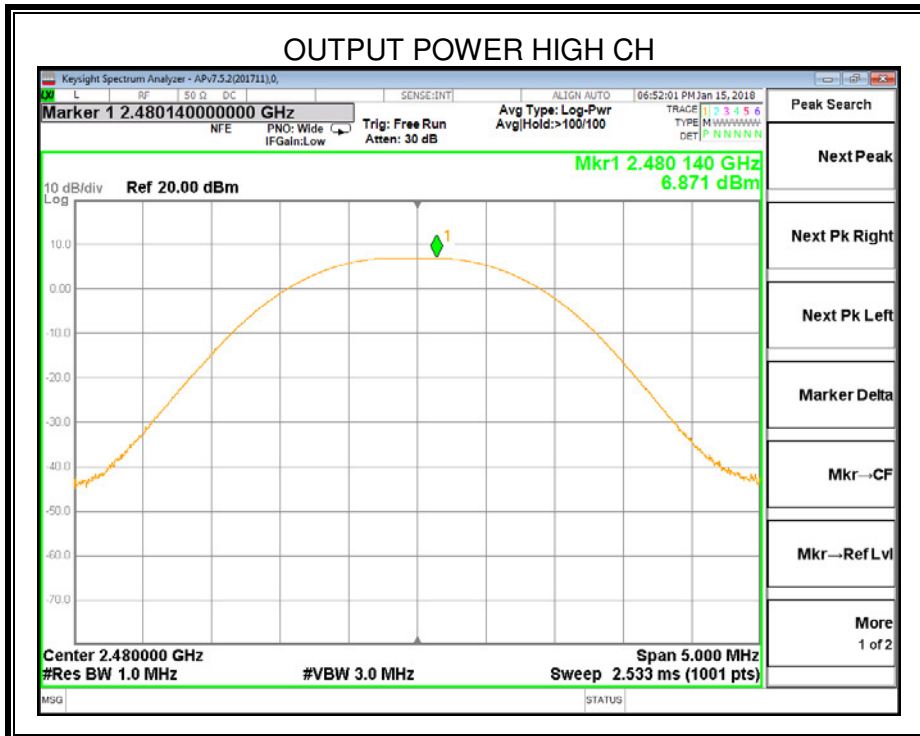
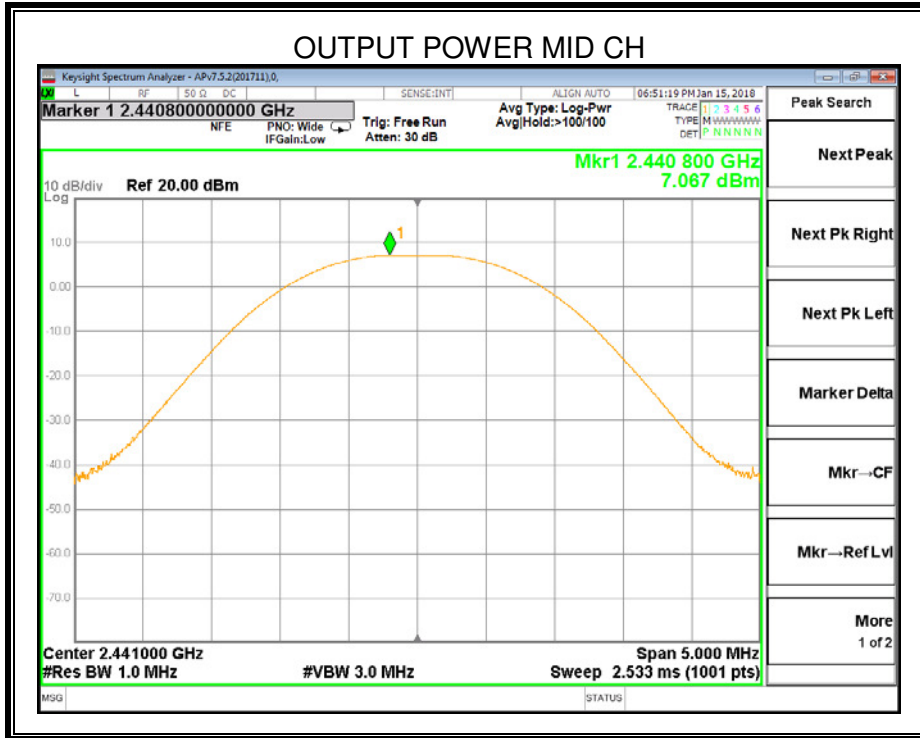

**6.3.2. 8DPSK MODE**

Channel	Frequency	Maximum Conducted Output Power(PK)	EIRP	Result
	(MHz)	(dBm)	(dBm)	
Low	2402	3.61	8.58	Pass
Middle	2441	3.53	8.50	Pass
High	2480	3.31	8.28	Pass

Note: EIRP= Maximum Conducted Output Power + Antenna Gain

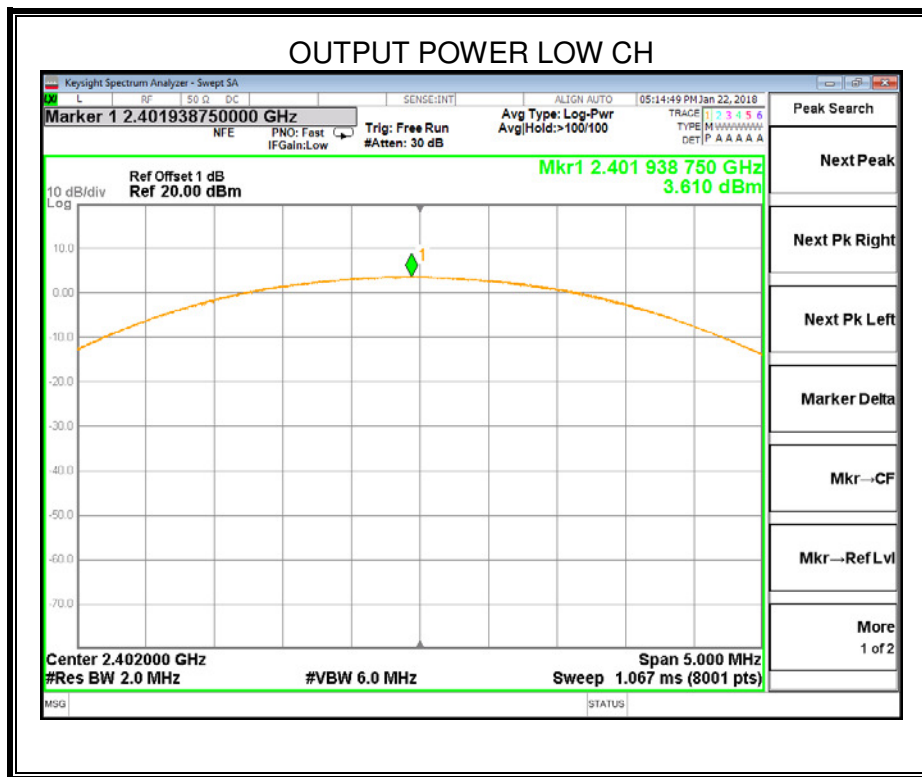

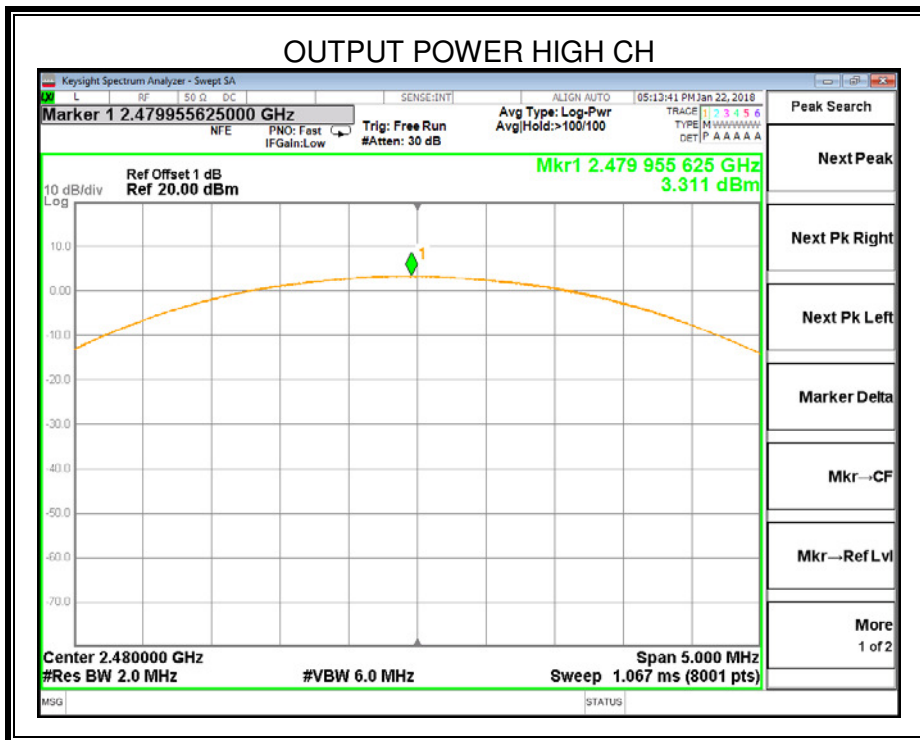
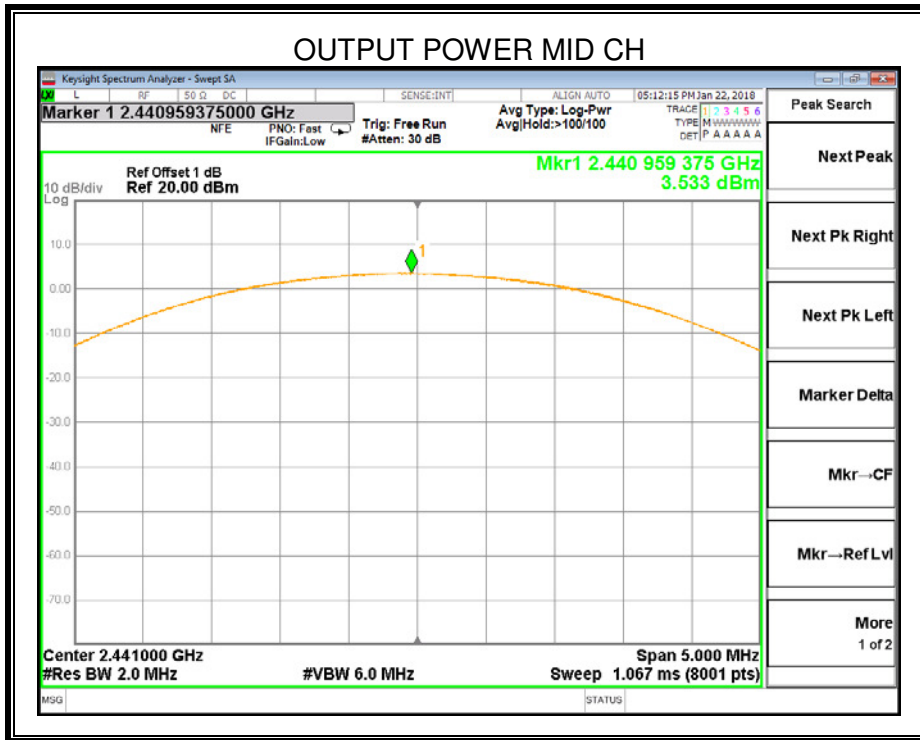

## 6.4. CARRIER HOPPING CHANNEL SEPARATION

### LIMITS

FCC Part15 (15.247) , Subpart C RSS-247 ISSUE 2			
Section	Test Item	Limit	Frequency Range (MHz)
FCC 15.247 (a) (1) RSS-247 Clause 5.1 (b)	Carrier Hopping Channel Separation	25 kHz or two-thirds of the 20 dB bandwidth of the hopping channel, whichever is greater.	2400-2483.5

### TEST PROCEDURE

Connect the UUT to the spectrum analyser and use the following settings:

Center Frequency	The centre frequency of the channel under test
Span	wide enough to capture the peaks of two adjacent channels
Detector	Peak
RBW	≥ 1% of the span
VBW	≥RBW
Trace	Max hold
Sweep time	Auto couple

Allow the trace to stabilize. Use the marker-delta function to determine the separation between the peaks of the adjacent channels. The limit is specified in one of the subparagraphs of this Section. Submit this plot.

### TEST SETUP

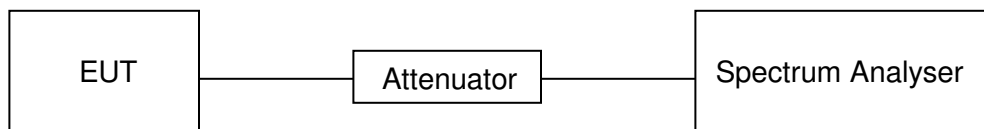

**RESULTS**

**ANTENNA1**

**6.4.1. GFSK MODE**

Channel	Carrier Hopping Channel Separation (MHz)	Limit (MHz)	Result
Middle	0.99	≥ two-thirds of the 20 dB Bandwidth Of The Hopping Channel	PASS

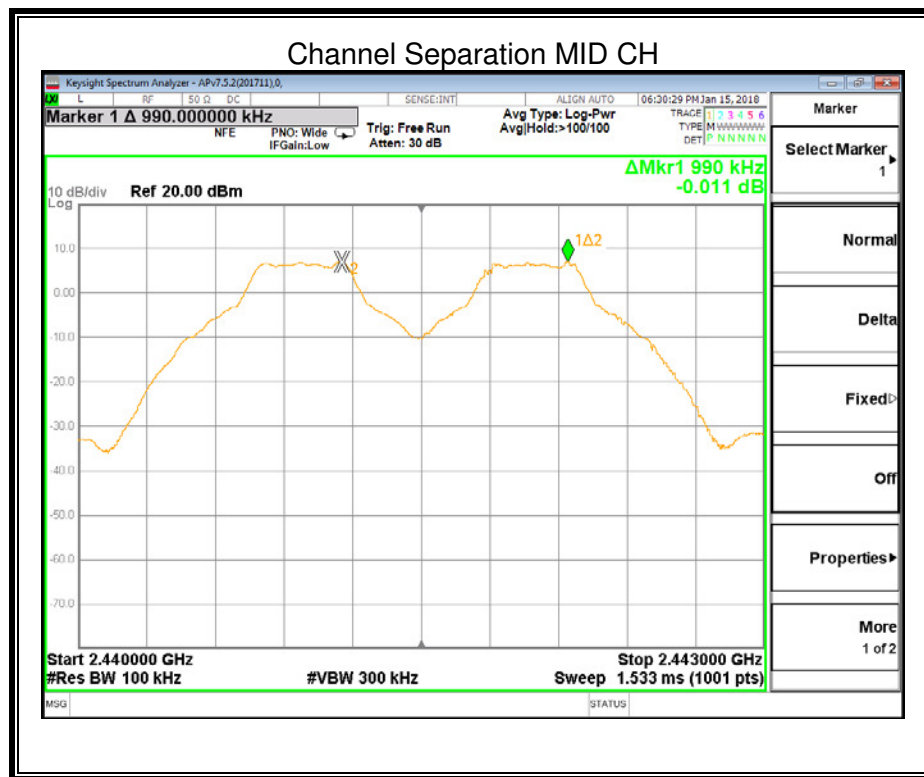

Note: For 20 dB Bandwidth of The Hopping Channel, please refer to clause 6.2.1.

### 6.4.2. 8DPSK MODE

Channel	Carrier Hopping Channel Separation (MHz)	Limit (MHz)	Result
Middle	1.005	≥ two-thirds of the 20 dB Bandwidth Of The Hopping Channel	PASS

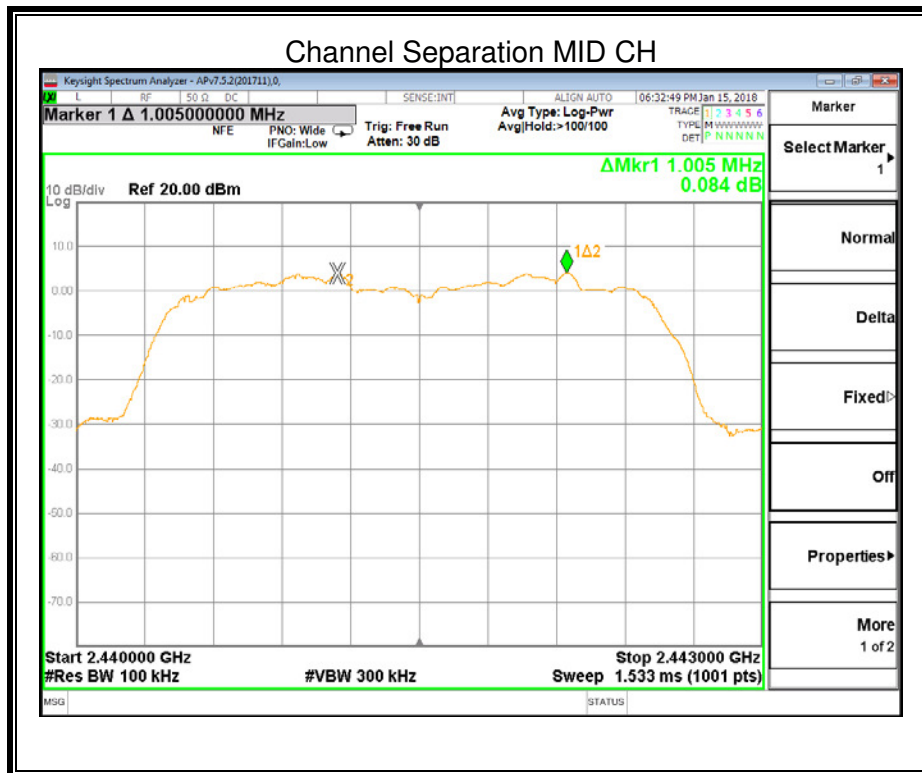

Note: For 20 dB Bandwidth of The Hopping Channel, please refer to clause 6.2.1.

## 6.5. NUMBER OF HOPPING FREQUENCY

### LIMITS

FCC Part15 (15.247) , Subpart C RSS-247 ISSUE 2		
Section	Test Item	Limit
15.247 (a) (1) III RSS-247 Clause 5.1 (d)	Number of Hopping Frequency	at least 15 hopping channels

### TEST PROCEDURE

Connect the EUT to the spectrum analyser and use the following settings:

Detector	Peak
RBW	1% of the span
VBW	≥RBW
Span	The frequency band of operation
Trace	Max hold
Sweep time	Auto couple

Set EUT to transmit maximum output power and switch on frequency hopping function. then set enough count time (larger than 5000 times) to get all the hopping frequency channel displayed on the screen of spectrum analyzer.

Count the quantity of peaks to get the number of hopping channels.

Normal Mode: 79 Channels observed.

AFH Mode: 20 Channels declared.

### TEST SETUP

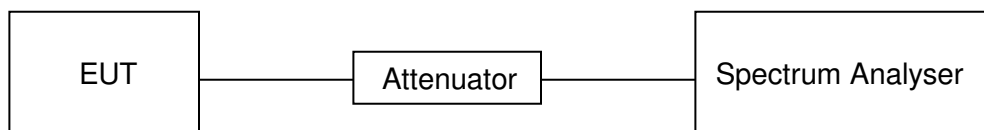

### RESULTS

#### ANTENNA1

### 6.5.1. GFSK MODE

Hopping numbers	Limit	Results
79	>15	Pass

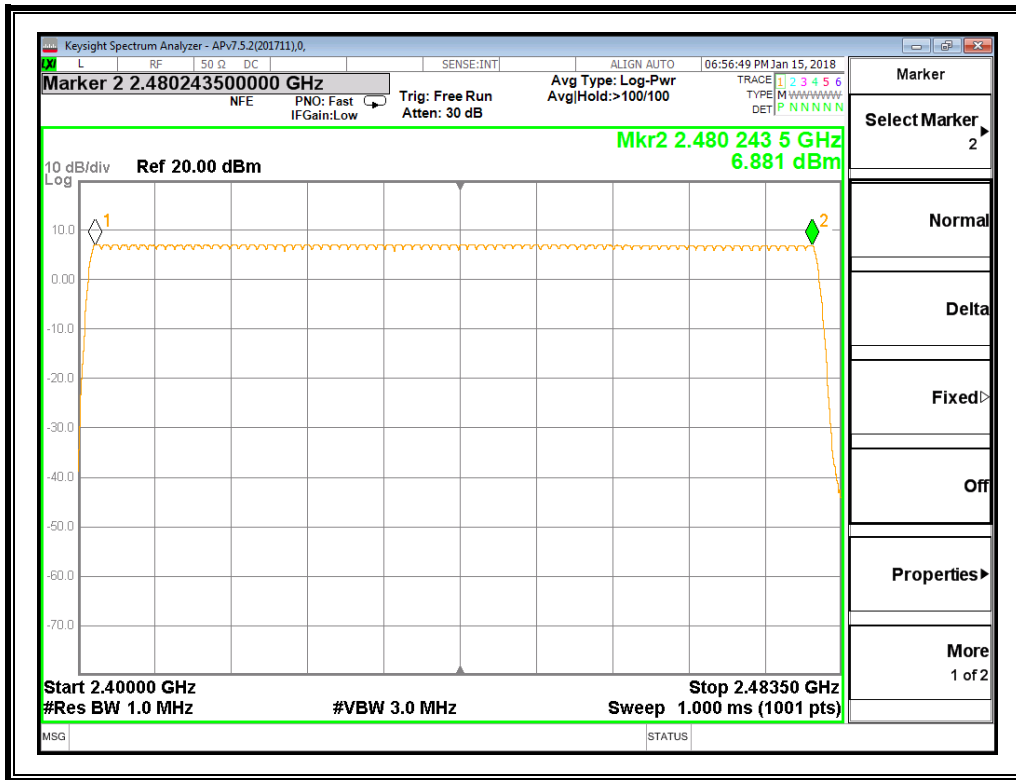

### 6.5.2. 8DPSK MODE

Hopping numbers	Limit	Results
79	>15	Pass

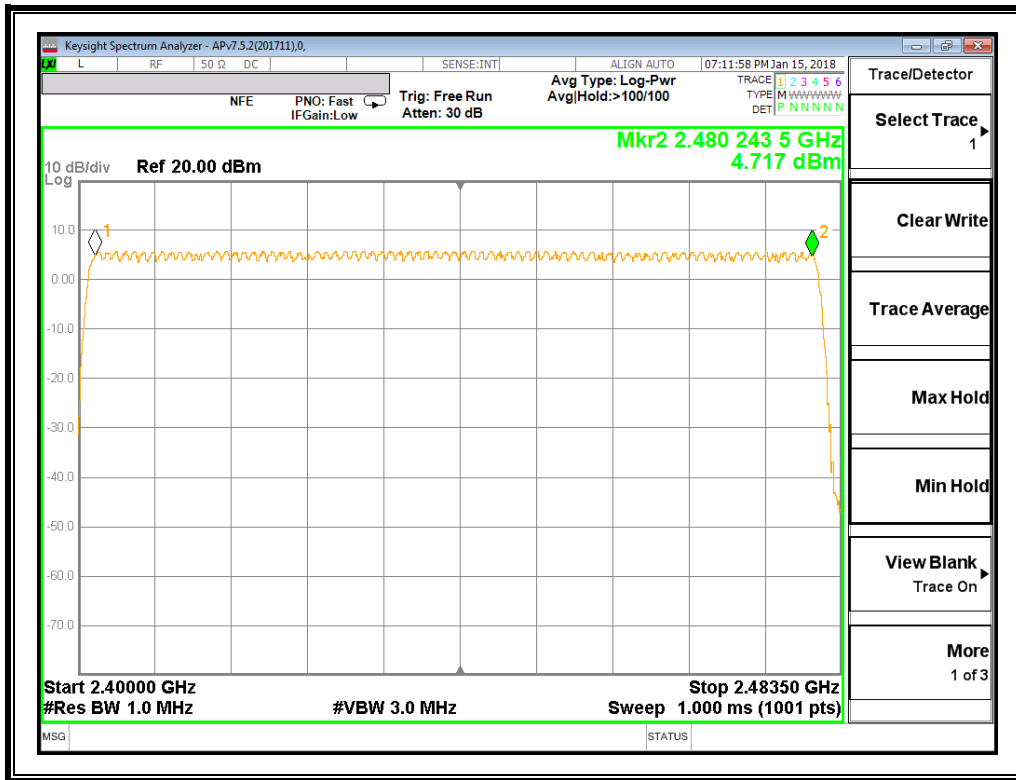

## 6.6. TIME OF OCCUPANCY (DWELL TIME)

### LIMITS

FCC Part15 (15.247) , Subpart C RSS-247 ISSUE 2		
Section	Test Item	Limit
15.247 (a) (1) III RSS-247 Clause 5.1 (d)	Time of Occupancy (Dwell Time)	The average time of occupancy on any channel shall not be greater than 0.4 seconds within a period of 0.4 seconds, multiplied by the number of hopping channels employed.

### TEST PROCEDURE

Connect the UUT to the spectrum analyser and use the following settings:

Center Frequency	The centre frequency of the channel under test
Detector	Peak
RBW	1 MHz
VBW	≥RBW
Span	zero span
Trace	Max hold
Sweep time	As necessary to capture the entire dwell time per hopping channel

- The transmitter output (antenna port) was connected to the spectrum analyzer
- Set RBW of spectrum analyzer to 1MHz and VBW to 1MHz.
- Use a video trigger with the trigger level set to enable triggering only on full pulses.
- Sweep Time is more than once pulse time.
- Set the center frequency on any frequency would be measure and set the frequency span to zero span.
- Measure the maximum time duration of one single pulse.
- Set the EUT for DH5, DH3 and DH1 packet transmitting.
- Measure the maximum time duration of one single pulse.  
 $A \text{ Period Time} = (\text{channel number}) * 0.4$

For Normal Mode (79 Channel):

DH1 Time Slot: Reading \* (1600/2)\*31.6/(channel number)

DH3 Time Slot: Reading \* (1600/4)\*31.6/(channel number)

DH5 Time Slot: Reading \* (1600/6)\*31.6/(channel number)

For AFH Mode (20 Channel):

DH1 Time Slot: Reading \* (1600/2)\*8/(channel number)

DH3 Time Slot: Reading \* (1600/4)\*8/(channel number)

DH5 Time Slot: Reading \* (1600/6)\*8/(channel number)

### TEST SETUP

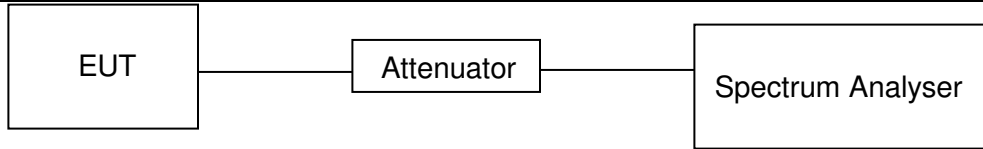

**RESULTS**

ANTENNA1

**6.6.1. GFSK MODE**

Normal Mode				
Packet	Channel	Burst Width [ms/hop/ch]	Dwell Time [ms]	Results
DH1	MCH	0.3800	0.1216	PASS
DH3	MCH	1.6200	0.2592	PASS
DH5	MCH	2.8600	0.3051	PASS
AFH Mode				
DH1	MCH	0.3800	0.1216	PASS
DH3	MCH	1.6200	0.2592	PASS
DH5	MCH	2.8600	0.3051	PASS

**Test Graph**

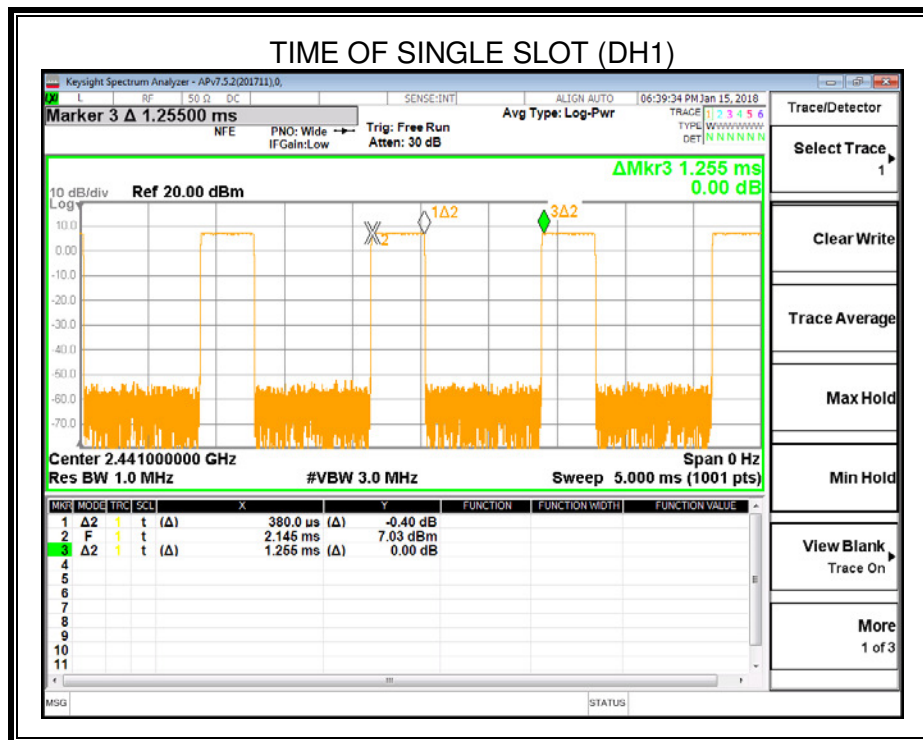

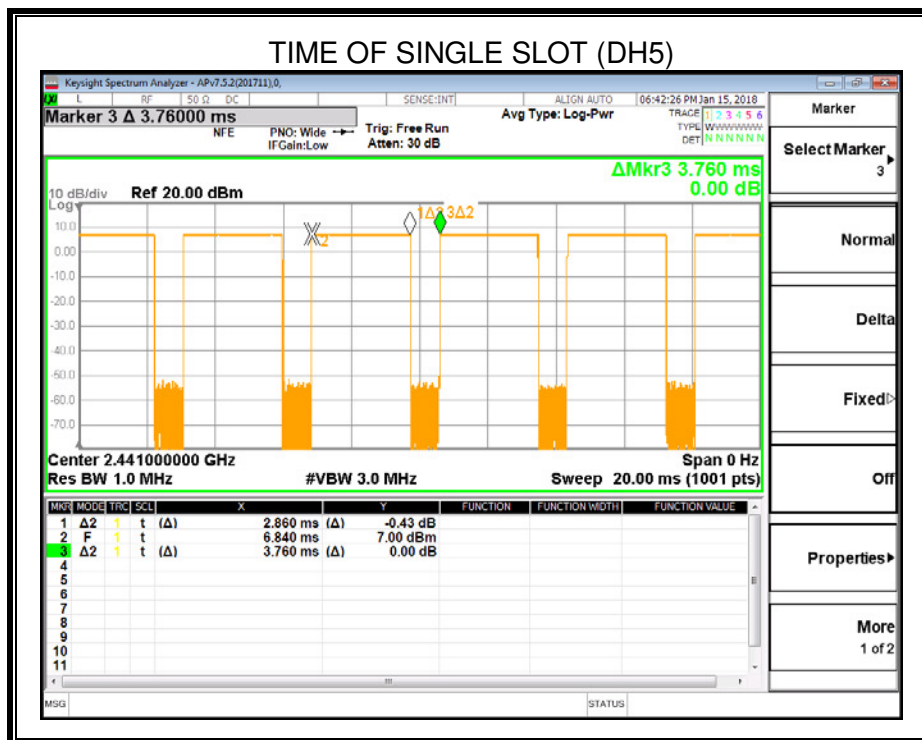
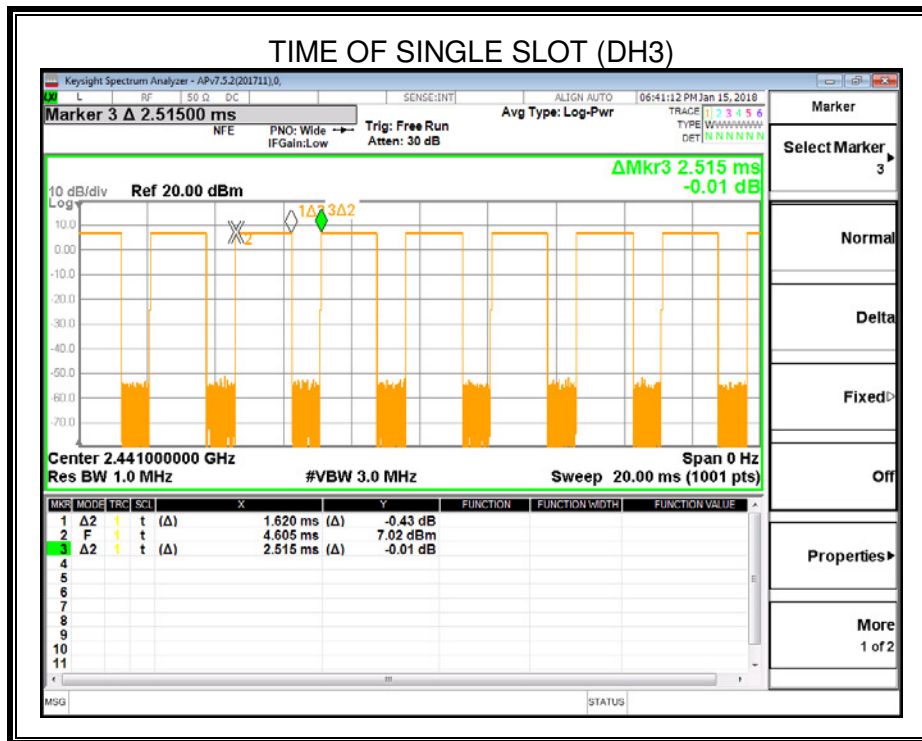

### 6.6.2. 8DPSK MODE

Normal Mode				
Packet	Channel	Burst Width [ms/hop/ch]	Dwell Time [ms]	Results
3DH1	MCH	0.3900	0.1248	PASS
3DH3	MCH	1.6400	0.2624	PASS
3DH5	MCH	2.8800	0.3072	PASS
AFH Mode				
3DH1	MCH	0.3900	0.1248	PASS
3DH3	MCH	1.6400	0.2624	PASS
3DH5	MCH	2.8800	0.3072	PASS

### Test Graph

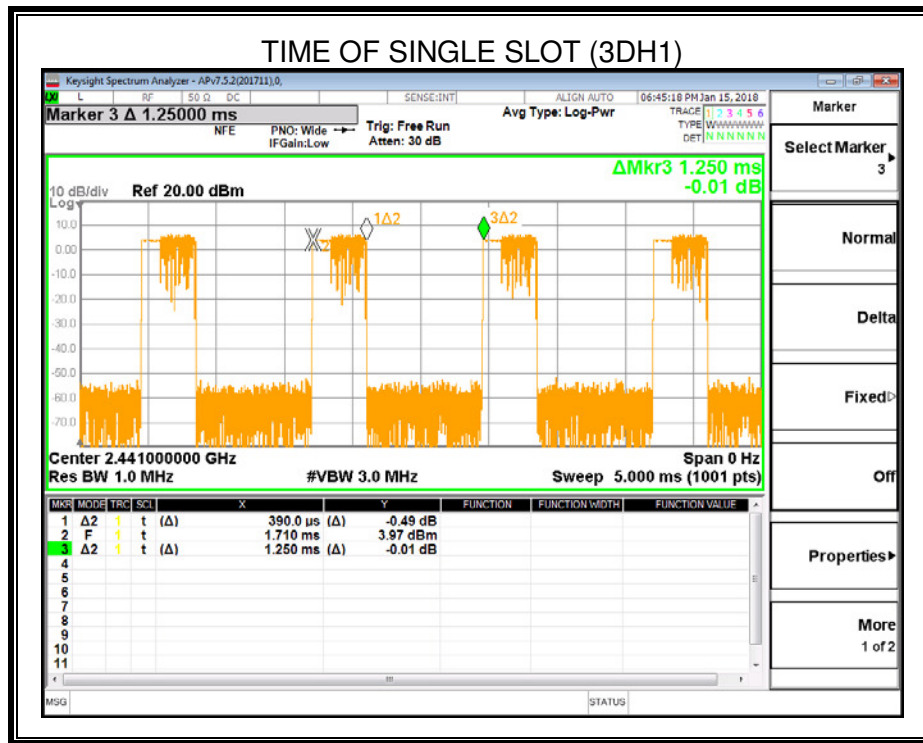

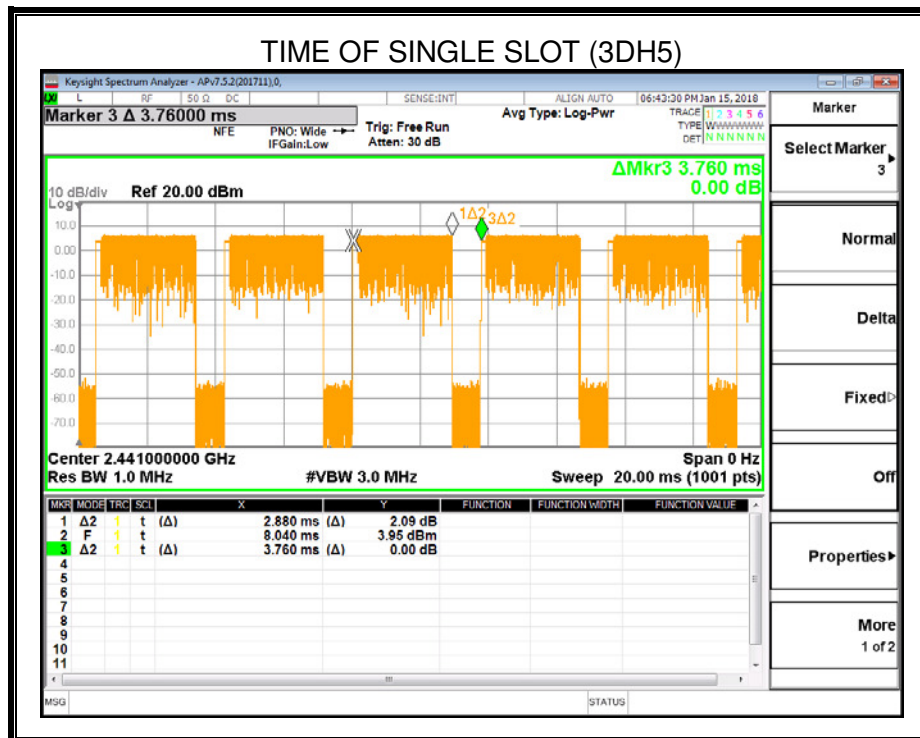
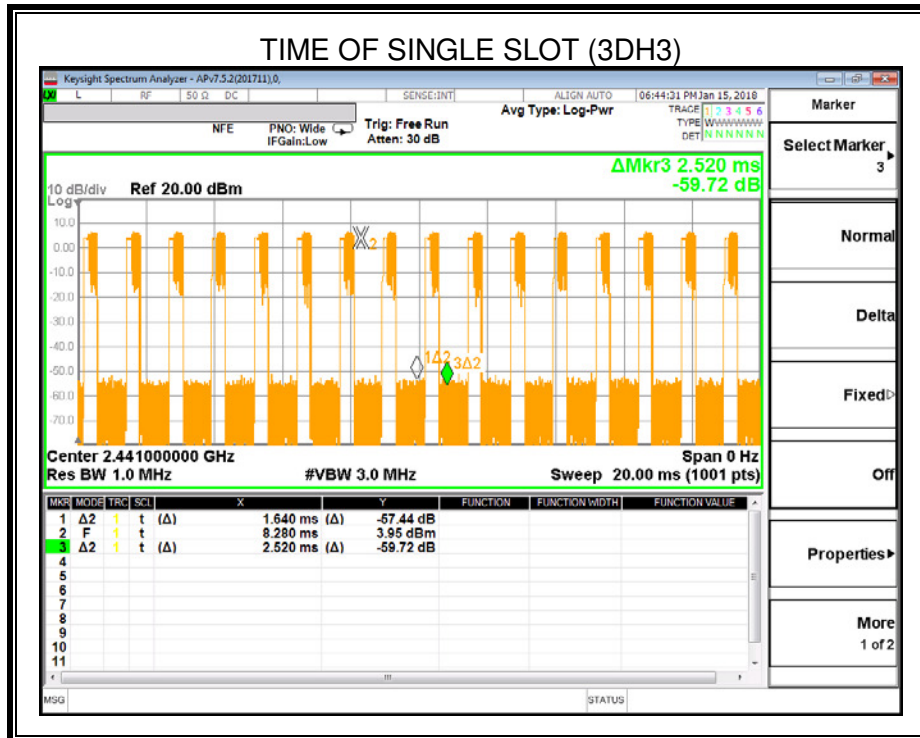

## 6.7. CONDUCTED SPURIOUS EMISSION

### LIMITS

FCC Part15 (15.247) , Subpart C RSS-247 ISSUE 2		
Section	Test Item	Limit
FCC §15.247 (d) RSS-247 5.5	Conducted Spurious Emission	at least 20 dB below that in the 100 kHz bandwidth within the band that contains the highest level of the desired power

### TEST PROCEDURE

For Bandedge use the following settings:

Detector	Peak
RBW	RBW $\geq$ 1% of the span
VBW	$\geq$ RBW
Span	wide enough to fully capture the emission being measured
Trace	Max hold
Sweep time	Auto couple.

For Spurious Emission use the following settings:

Detector	Peak
RBW	100K
VBW	$\geq$ RBW
Span	wide enough to fully capture the emission being measured
Trace	Max hold
Sweep time	Auto couple.

Use the peak marker function to determine the maximum amplitude level.

### TEST SETUP

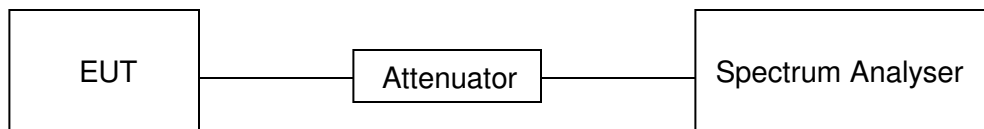

**RESULTS**

ANTENNA1

**6.7.1. GFSK MODE**

**SPURIOUS EMISSIONS, LOW CHANNEL**

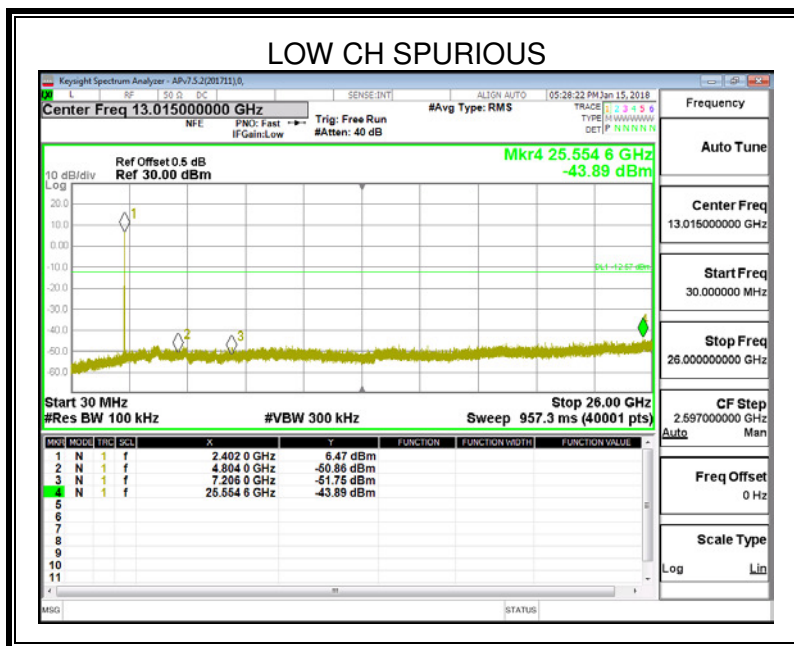
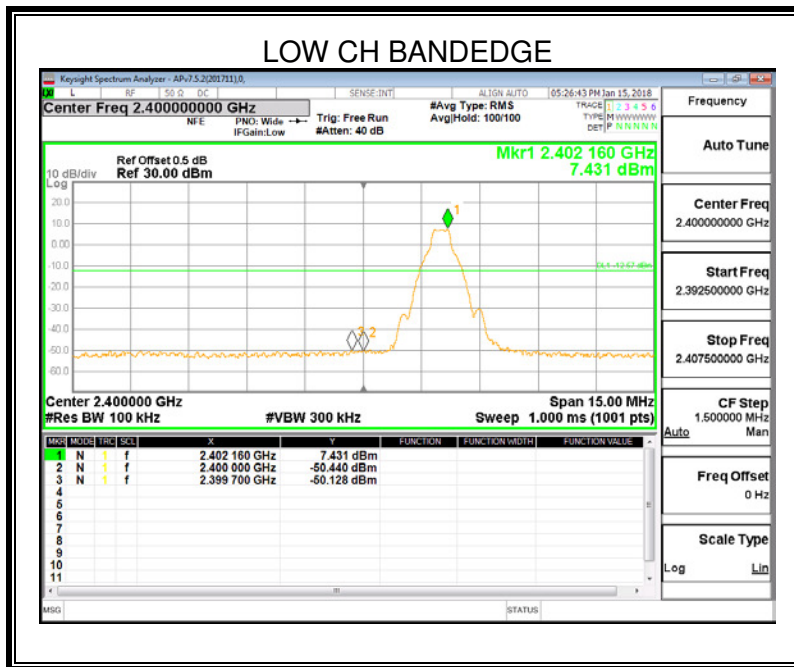

**SPURIOUS EMISSIONS, MID CHANNEL**

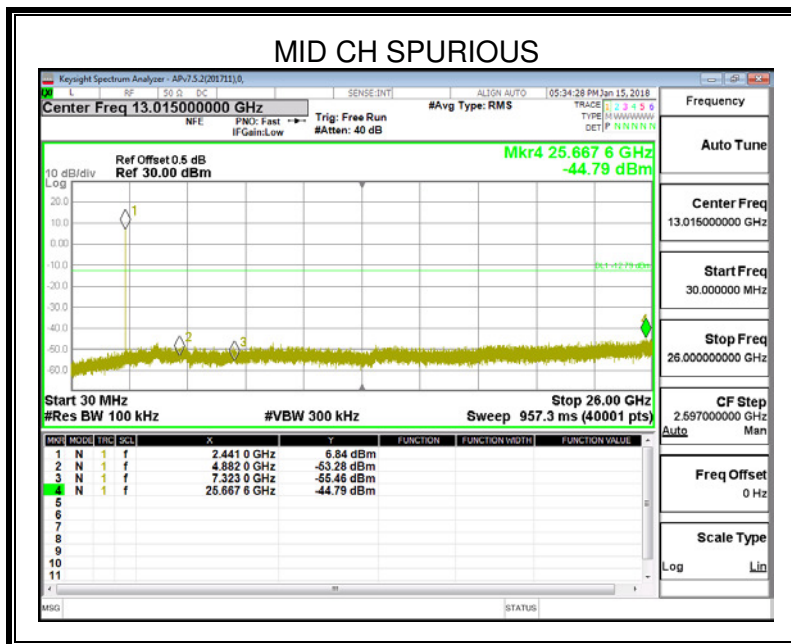
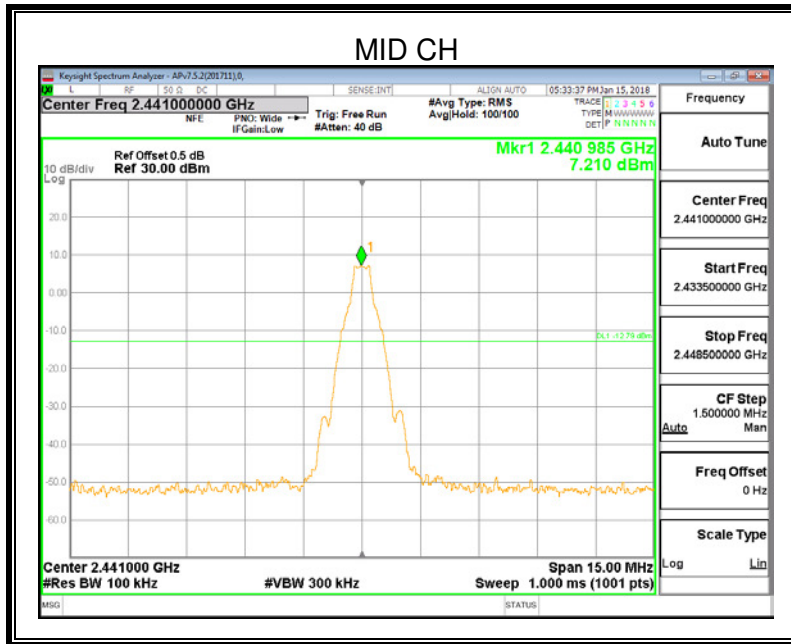

**SPURIOUS EMISSIONS, HIGH CHANNEL**

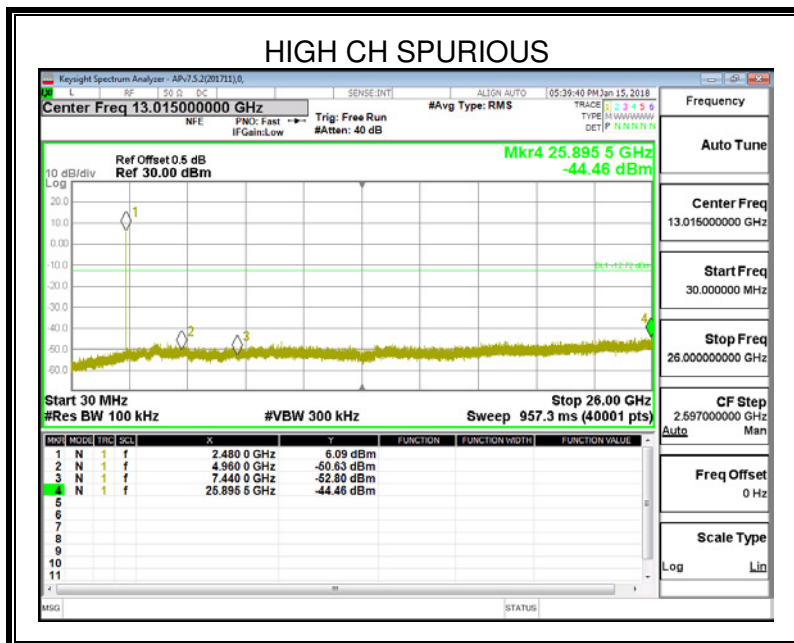
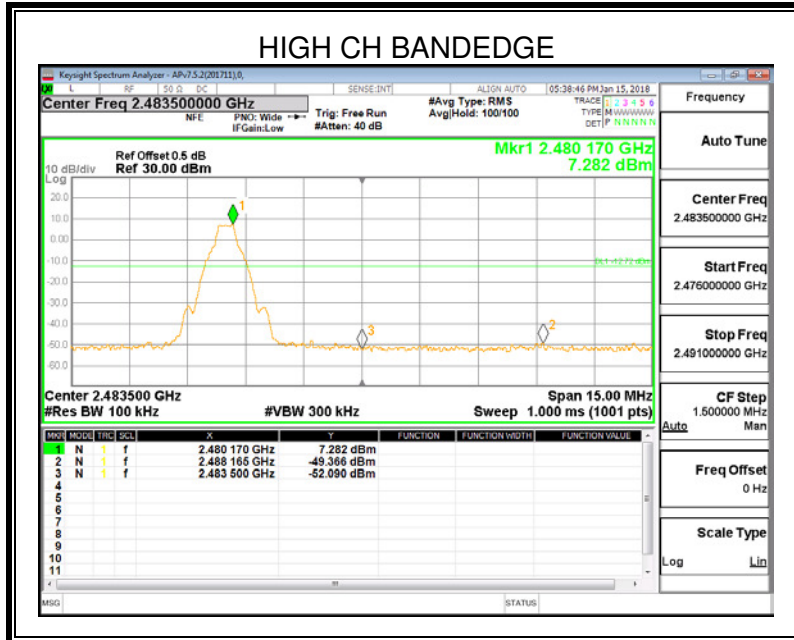

**SPURIOUS BANDEDGE EMISSIONS WITH HOPPING ON**

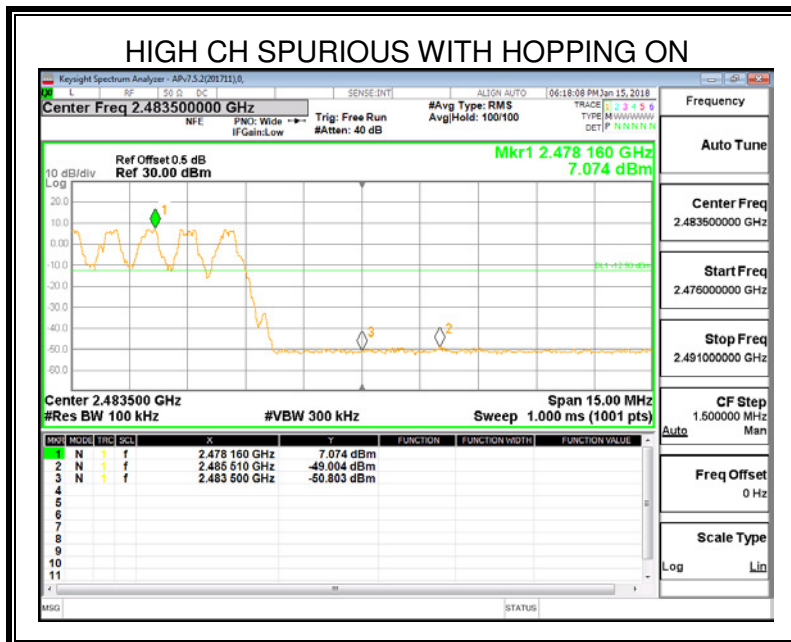
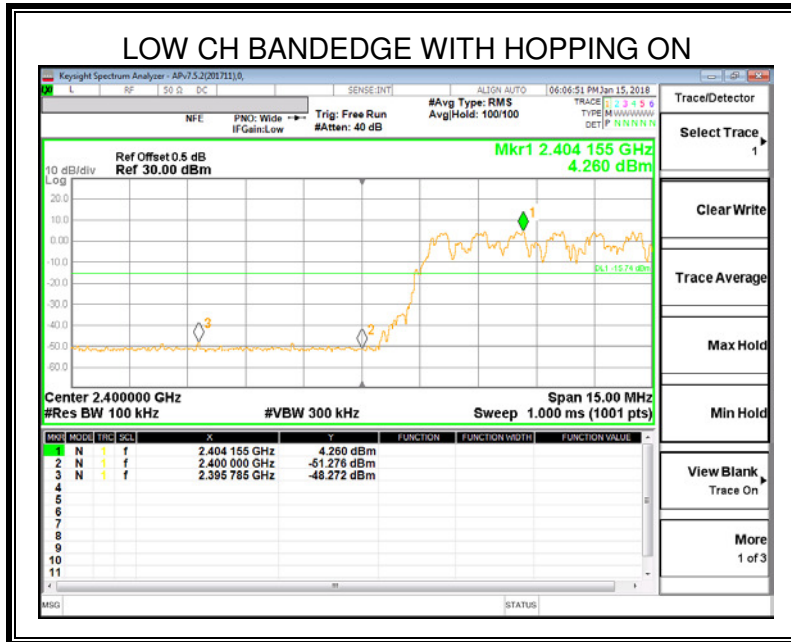

### 6.7.2. 8DPSK MODE

#### SPURIOUS EMISSIONS, LOW CHANNEL

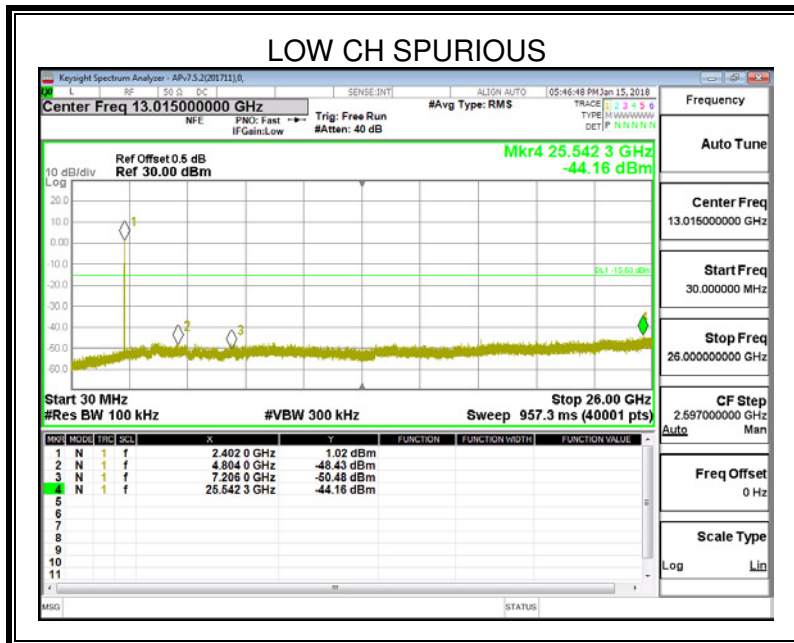
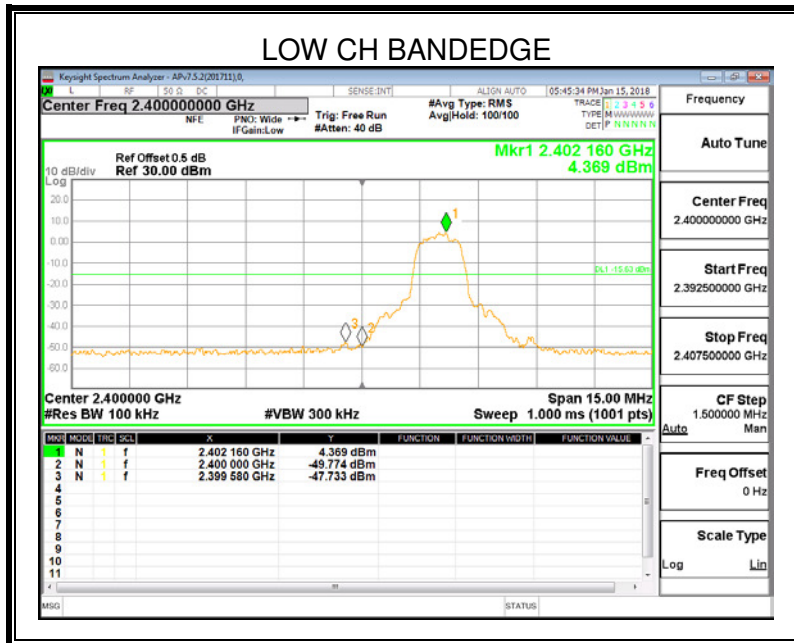

**SPURIOUS EMISSIONS, MID CHANNEL**

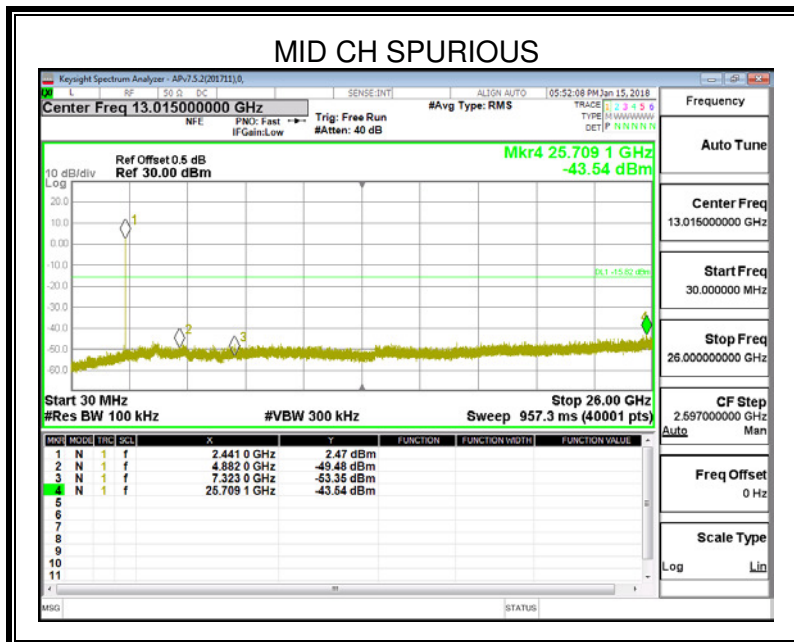
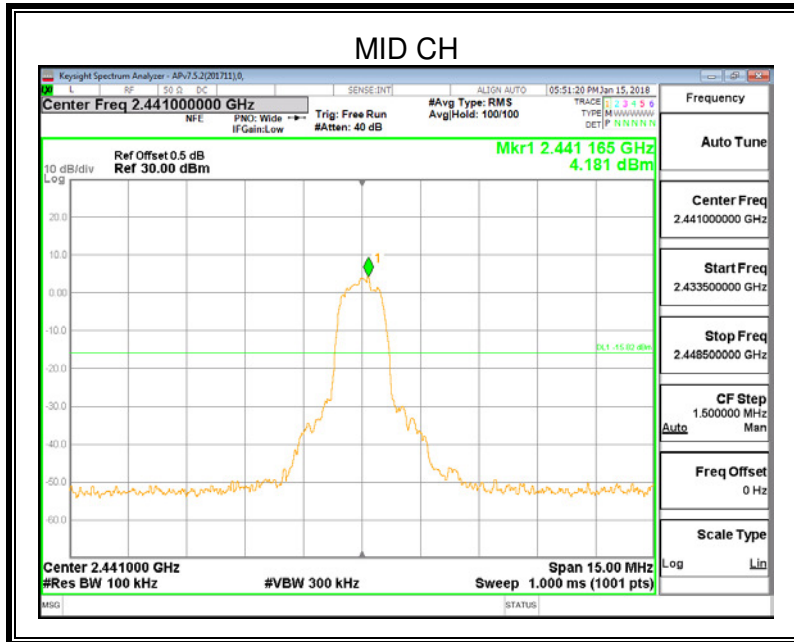

**SPURIOUS EMISSIONS, HIGH CHANNEL**

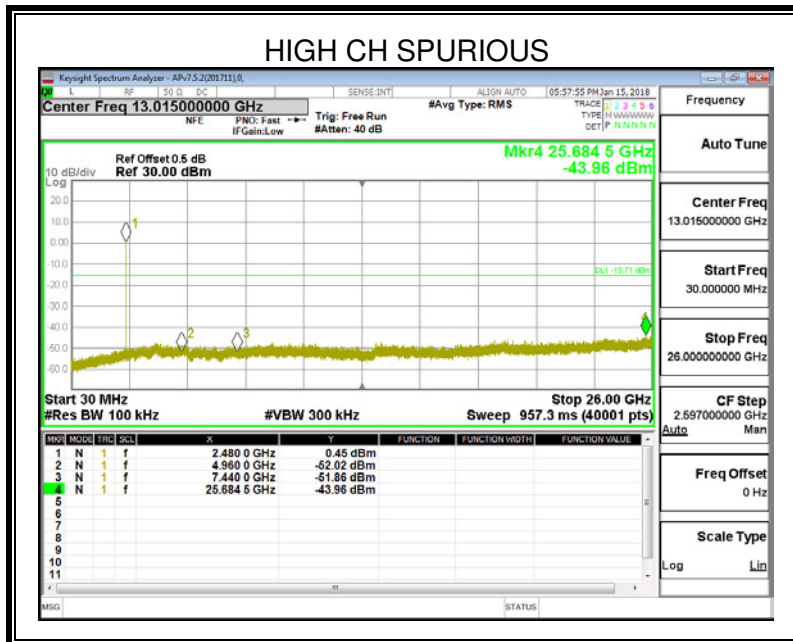
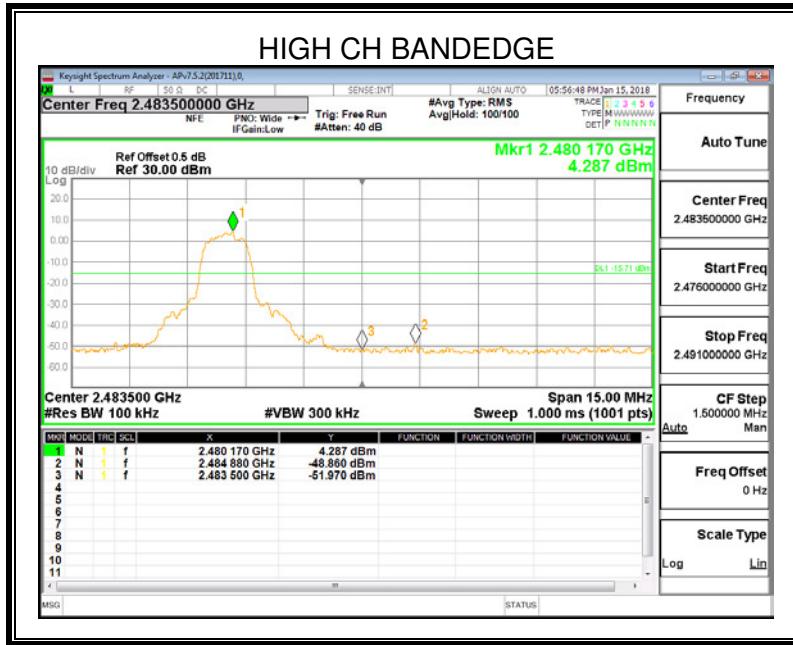

**SPURIOUS BANDEDGE EMISSIONS WITH HOPPING ON**

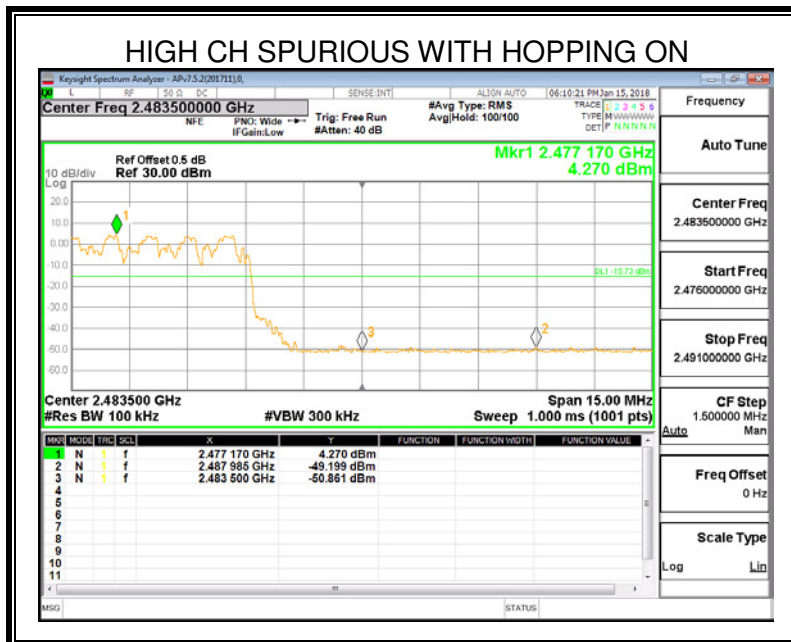
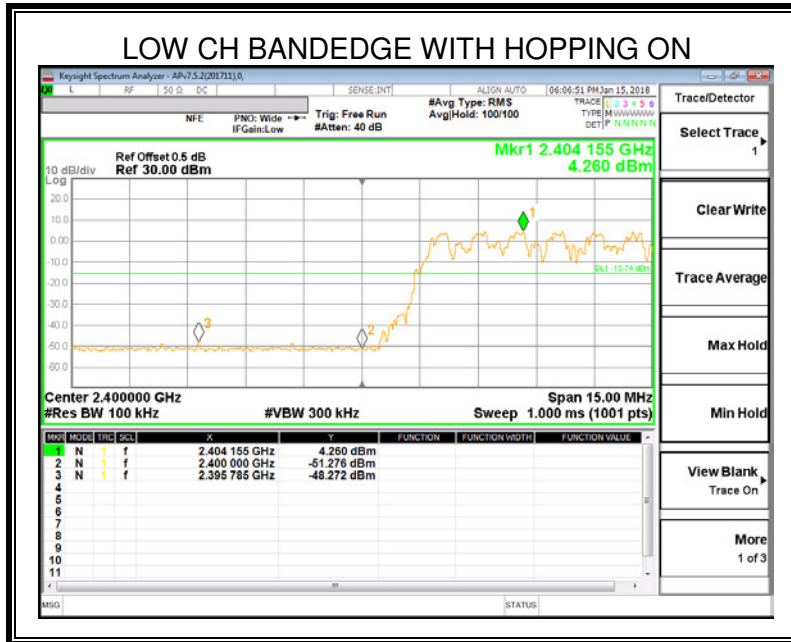

## 7. RADIATED TEST RESULTS

### 7.1. LIMITS AND PROCEDURE

#### LIMITS

Please refer to FCC §15.205 and §15.209

Please refer to SS-GEN Clause 8.9 and Clause 8.10

Radiation Disturbance Test Limit for FCC (Class B)(9KHz-1GHz)

Frequency (MHz)	Field Strength (microvolts/meter)	Measurement Distance (meters)
0.009~0.490	2400/F(KHz)	300
0.490~1.705	24000/F(KHz)	30
1.705~30.0	30	30
30~88	100	3
88~216	150	3
216~960	200	3
960~1000	500	3

Note: 1) At frequencies at or above 30 MHz, measurements may be performed at a distance other than what is specified provided: measurements are not made in the near field except where it can be shown that near field measurements are appropriate due to the characteristics of the device; and it can be demonstrated that the signal levels needed to be measured at the distance employed can be detected by the measurement equipment. Measurements shall not be performed at a distance greater than 30 meters unless it can be further demonstrated that measurements at a distance of 30 meters or less are impractical. When performing measurements at a distance other than that specified, the results shall be extrapolated to the specified distance using an extrapolation factor of 20 dB/decade (inverse linear-distance for field strength measurements; inverse-linear-distance-squared for power density measurements).

(2) At frequencies below 30 MHz, measurements may be performed at a distance closer than that specified in the regulations; however, an attempt should be made to avoid making measurements in the near field. Pending the development of an appropriate measurement procedure for measurements performed below 30 MHz, when performing measurements at a closer distance than specified, the results shall be extrapolated to the specified distance by either making measurements at a minimum of two distances on at least one radial to determine the proper extrapolation factor or by using the square of an inverse linear distance extrapolation factor (40 dB/decade). This paragraph (f) shall not apply to Access BPL devices operating below 30 MHz.

Radiation Disturbance Test Limit for FCC (Above 1G)

Frequency (MHz)	dB(uV/m) (at 3 meters)	
	Peak	Average
Above 1000	74	54

Restricted bands of operation

MHz	MHz	MHz	GHz
0.090-0.110	16.42-16.423	399.9-410	4.5-5.15
<sup>1</sup> 0.495-0.505	16.69475-16.69525	608-614	5.35-5.46
2.1735-2.1905	16.80425-16.80475	960-1240	7.25-7.75
4.125-4.128	25.5-25.67	1300-1427	8.025-8.5
4.17725-4.17775	37.5-38.25	1435-1626.5	9.0-9.2
4.20725-4.20775	73-74.6	1645.5-1646.5	9.3-9.5
6.215-6.218	74.8-75.2	1660-1710	10.6-12.7
6.26775-6.26825	108-121.94	1718.8-1722.2	13.25-13.4
6.31175-6.31225	123-138	2200-2300	14.47-14.5
8.291-8.294	149.9-150.05	2310-2390	15.35-16.2
8.362-8.366	156.52475-156.52525	2483.5-2500	17.7-21.4
8.37625-8.38675	156.7-156.9	2690-2900	22.01-23.12
8.41425-8.41475	162.0125-167.17	3260-3267	23.6-24.0
12.29-12.293	167.72-173.2	3332-3339	31.2-31.8
12.51975-12.52025	240-285	3345.8-3358	36.43-36.5
12.57675-12.57725	322-335.4	3600-4400	( <sup>2</sup> )
13.36-13.41			

Note: <sup>1</sup>Until February 1, 1999, this restricted band shall be 0.490-0.510 MHz.

<sup>2</sup>Above 38.6c

**TEST SETUP AND PROCEDURE**

Below 30MHz

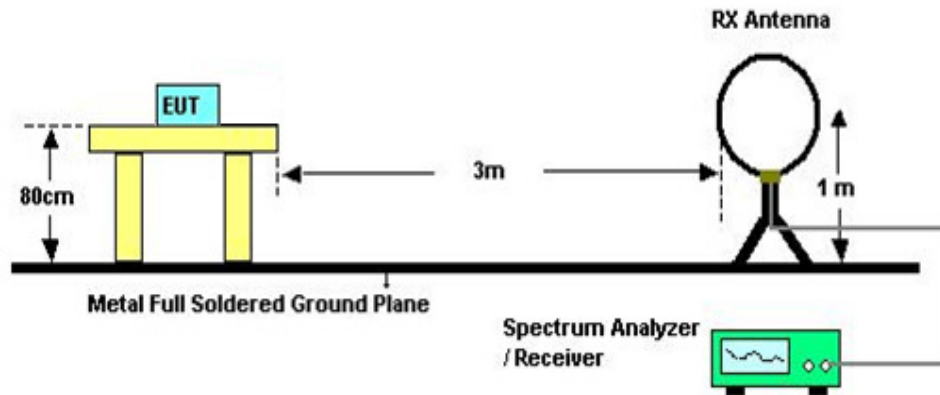

The setting of the spectrum analyser

RBW	200Hz (From 9kHz to 0.15MHz)/ 9KHz (From 0.15MHz to 30MHz)
VBW	200Hz (From 9kHz to 0.15MHz)/ 9KHz (From 0.15MHz to 30MHz)
Sweep	Auto
Trace	Max hold

1. The testing follows the guidelines in ANSI C63.10-2013
2. The EUT was arranged to its worst case and then turntable (from 0 degree to 360 degrees) to find the maximum reading. A pre-amp and a high pass filter are used for the test in order to get better signal level. Both horizontal and vertical polarizations of the antenna are set to make the measurement.
3. The EUT was placed on a turntable with 80cm meter above ground.
4. The EUT was set 3 meters from the interference receiving antenna, which was mounted on the top of a variable height antenna tower.
5. The radiated emission limits are based on measurements employing a CISPR quasi-peak detector except for the frequency bands 9-90 kHz, 110-490 kHz and above 1000 MHz. Radiated emission limits in these three bands are based on measurements employing an average detector.
6. For measurement below 1GHz, the initial step in collecting conducted emission data is a spectrum analyzer peak detector mode pre-scanning the measurement frequency range. Significant peaks are then marked and then Quasi Peak detector mode re-measured. If the emission level of the EUT measured by the peak detector is 3 dB lower than the applicable limit, the peak emission level will be reported. Otherwise, the emission measurement will be repeated using the quasi-peak detector and reported.
7. For the actual test configuration, please refer to the related item in this test report (Photographs of the Test Configuration)

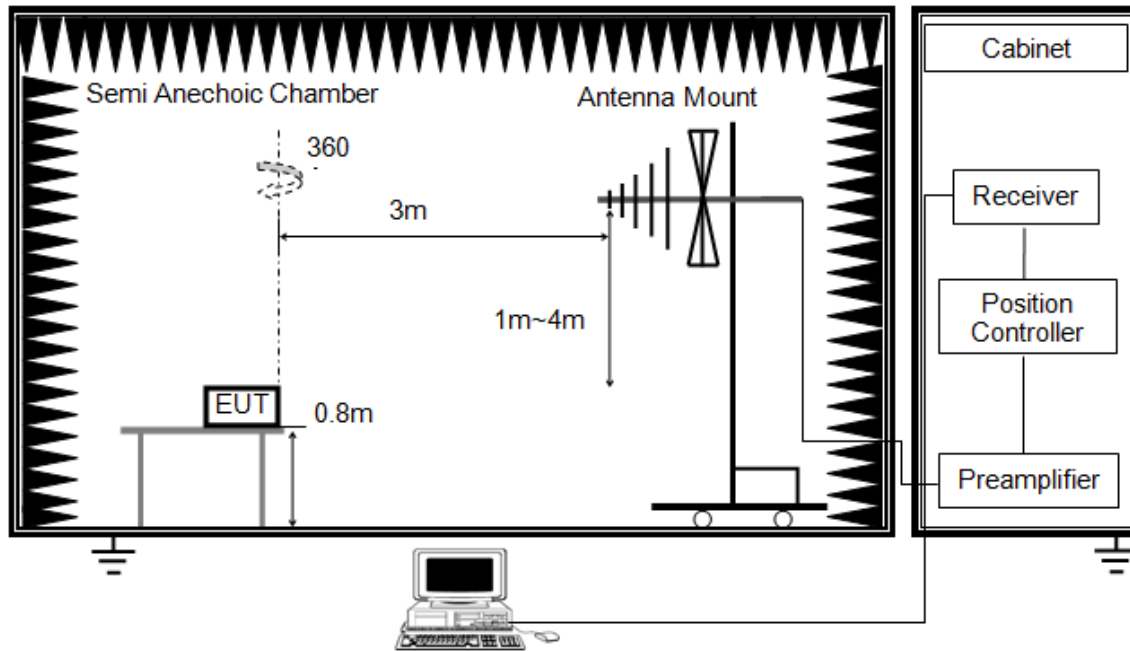

The setting of the spectrum analyser

RBW	120K
VBW	300K
Sweep	Auto
Trace	Max hold

1. The testing follows the guidelines in ANSI C63.10-2013.
2. The EUT was arranged to its worst case and then tune the antenna tower (from 1 m to 4 m) and turntable (from 0 degree to 360 degrees) to find the maximum reading. A pre-amp and a high pass filter are used for the test in order to get better signal level. Both horizontal and vertical polarizations of the antenna are set to make the measurement.
3. The EUT was placed on a turntable with 80cm above ground.
4. The EUT was set 3 meters from the interference receiving antenna, which was mounted on the top of a variable height antenna tower.
5. For measurement below 1GHz, the initial step in collecting conducted emission data is a spectrum analyzer peak detector mode pre-scanning the measurement frequency range. Significant peaks are then marked and then Quasi Peak detector mode re-measured. If the emission level of the EUT measured by the peak detector is 3 dB lower than the applicable limit, the peak emission level will be reported. Otherwise, the emission measurement will be repeated using the quasi-peak detector and reported.
6. For the actual test configuration, please refer to the related item in this test report.

Above 1G

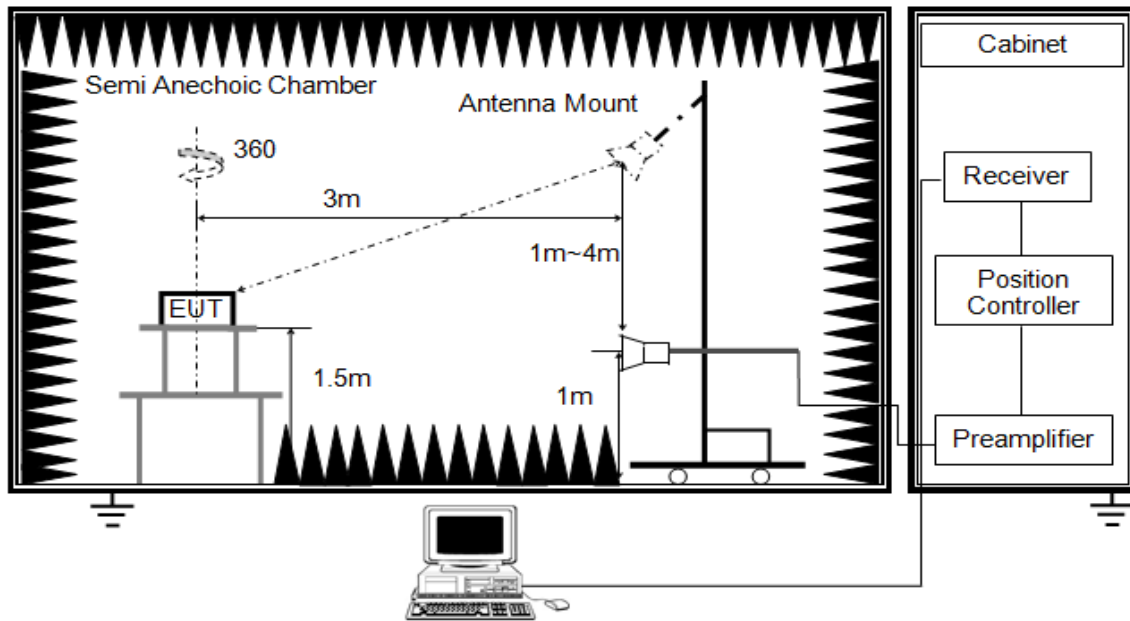

RBW	1M
VBW	PEAK: 3M AVG: see note 6
Sweep	Auto
Detector	Peak
Trace	Max hold

1. The testing follows the guidelines in ANSI C63.10-2013.
2. The EUT was arranged to its worst case and then tune the antenna tower (from 1 m to 4 m) and turntable (from 0 degree to 360 degrees) to find the maximum reading. A pre-amp and a high pass filter are used for the test in order to get better signal level. Both horizontal and vertical polarizations of the antenna are set to make the measurement.
3. The EUT was placed on a turntable with 80cm above ground.
4. The EUT was set 3 meters from the interference receiving antenna, which was mounted on the top of a variable height antenna tower.
5. For measurement above 1GHz, the emission measurement will be measured by the peak detector. This peak level, once corrected, must comply with the limit specified in Section 15.209.
6. For measurements above 1 GHz the resolution bandwidth is set to 1 MHz, then the video bandwidth is set to 3 MHz for peak measurements and 1 MHz resolution bandwidth with 1/T video bandwidth with peak detector. For the Duty Cycle please refer to clause 6.1.ON TIME AND DUTY CYCLE.
7. For the actual test configuration, please refer to the related item in this test report (Photographs of the Test Configuration)

X axis, Y axis, Z axis positions:

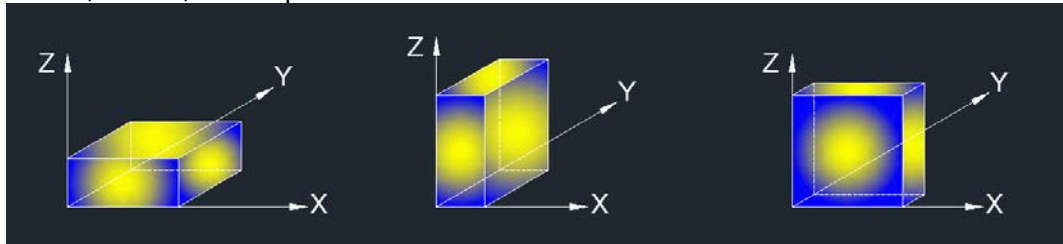

Note: For all radiated test, EUT in each of three orthogonal axis emissions had been tested, but only the worst case (Y axis) data recorded in the report.

## 7.2. RESTRICTED BANDEDGE

### 7.2.1. GFSK MODE

#### ANTENNA1 (WORST-CASE CONFIGURATION)

#### RESTRICTED BANDEDGE (LOW CHANNEL, HORIZONTAL)

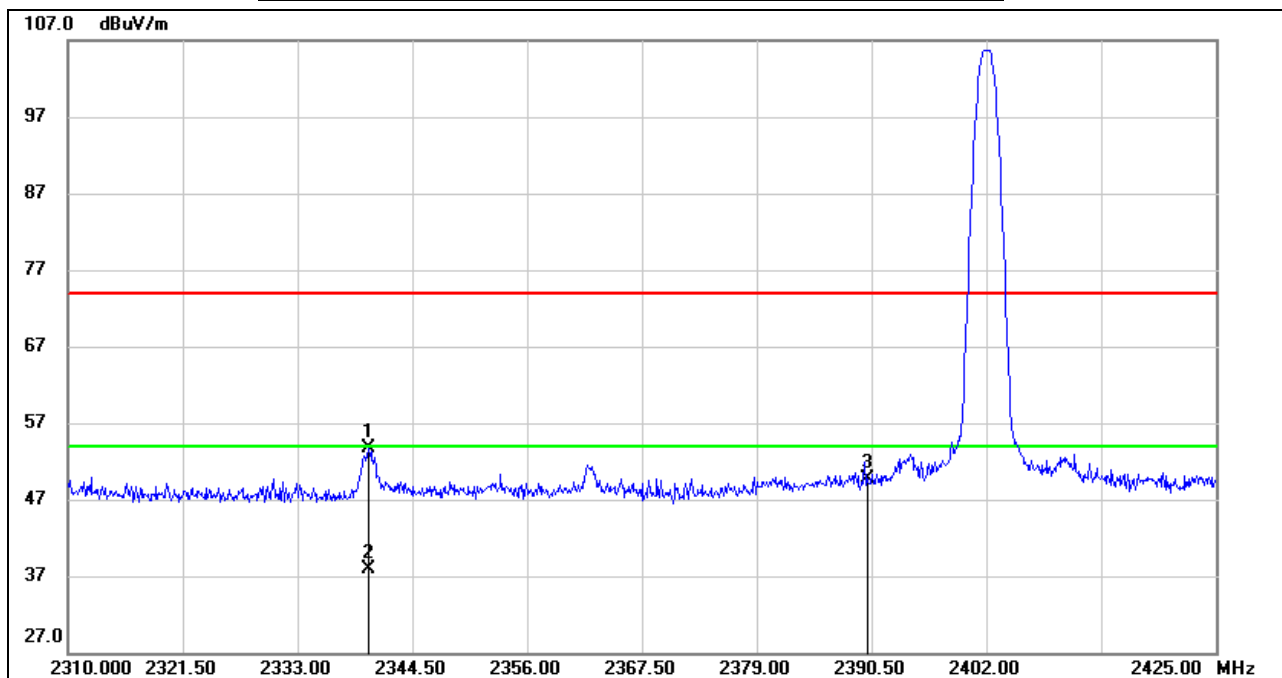

No.	Frequency (MHz)	Reading (dBuV/m)	Correct (dB/m)	Result (dBuV/m)	Limit (dBuV/m)	Margin (dB)	Remark
1	2340.130	20.22	33.50	53.72	74.00	-20.28	peak
2	2340.130	4.46	33.50	37.96	54.00	-16.04	AVG
3	2390.000	16.52	33.14	49.66	74.00	-24.34	peak

Note: 1. Measurement = Reading Level + Correct Factor.  
 2. If Peak Result complies with AV limit, AV Result is deemed to comply with AV limit.  
 3. Peak: Peak detector.  
 4. AVG:  $VBW=1/Ton$  where: ton is transmit duration.  
 5. For transmit duration, please refer to clause 6.1.

**RESTRICTED BANDEDGE (LOW CHANNEL, VERTICAL)**

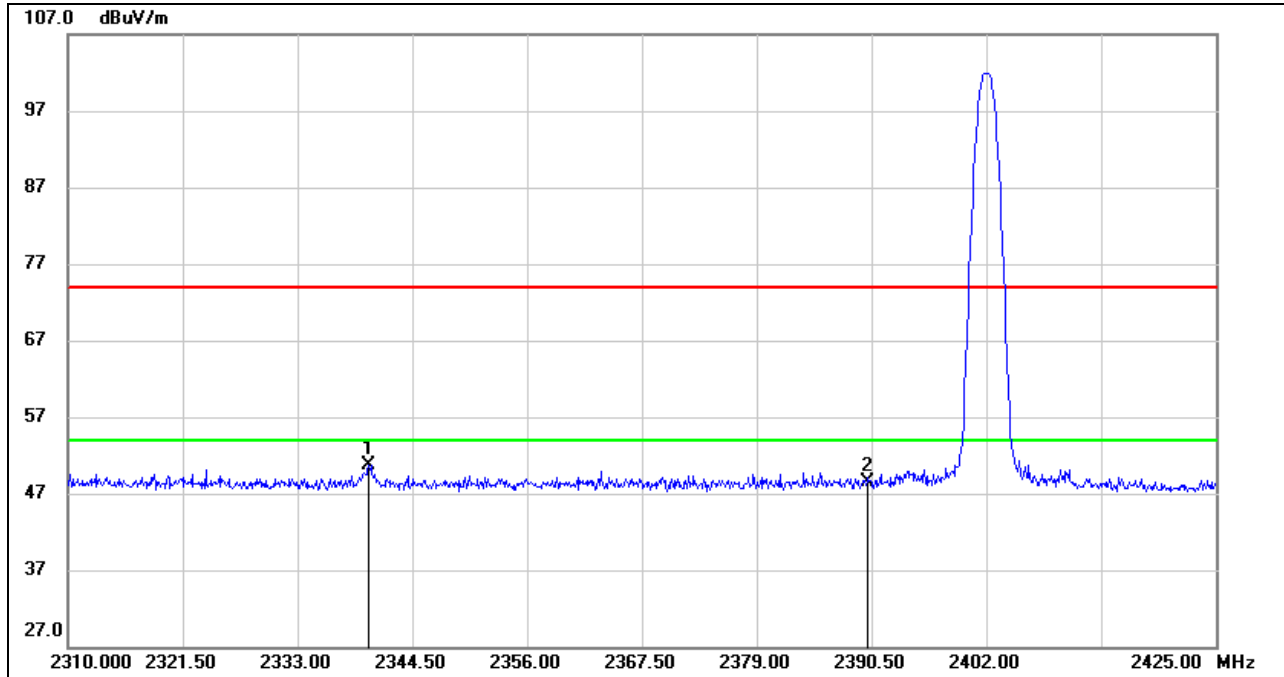

No.	Frequency (MHz)	Reading (dBuV/m)	Correct dB/m	Result (dBuV/m)	Limit (dBuV/m)	Margin (dB)	Remark
1	2340.130	17.17	33.62	50.79	74.00	-23.21	peak
2	2390.000	15.23	33.24	48.47	74.00	-25.53	peak

- Note: 1. Measurement = Reading Level + Correct Factor.  
 2. If Peak Result complies with AV limit, AV Result is deemed to comply with AV limit.  
 3. Peak: Peak detector.  
 4. AVG:  $VBW=1/Ton$  where: ton is transmit duration.  
 5. For transmit duration, please refer to clause 6.1.

**RESTRICTED BANDEDGE (HIGH CHANNEL, HORIZONTAL)**

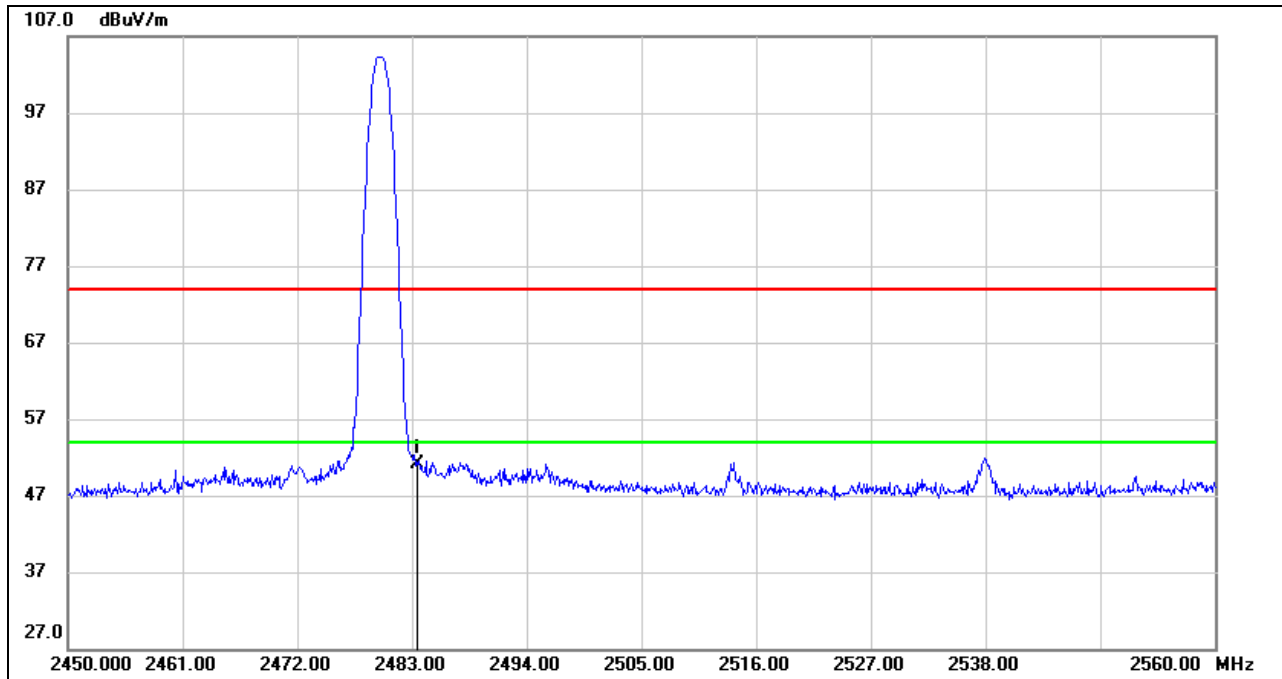

No.	Frequency (MHz)	Reading (dBuV/m)	Correct (dB/m)	Result (dBuV/m)	Limit (dBuV/m)	Margin (dB)	Remark
1	2483.500	18.33	32.78	51.11	74.00	-22.89	peak

- Note: 1. Measurement = Reading Level + Correct Factor.  
 2. If Peak Result complies with AV limit, AV Result is deemed to comply with AV limit.  
 3. Peak: Peak detector.  
 4. AVG:  $VBW=1/Ton$  where: ton is transmit duration.  
 5. For transmit duration, please refer to clause 6.1.

**RESTRICTED BANDEDGE (HIGH CHANNEL, VERTICAL)**

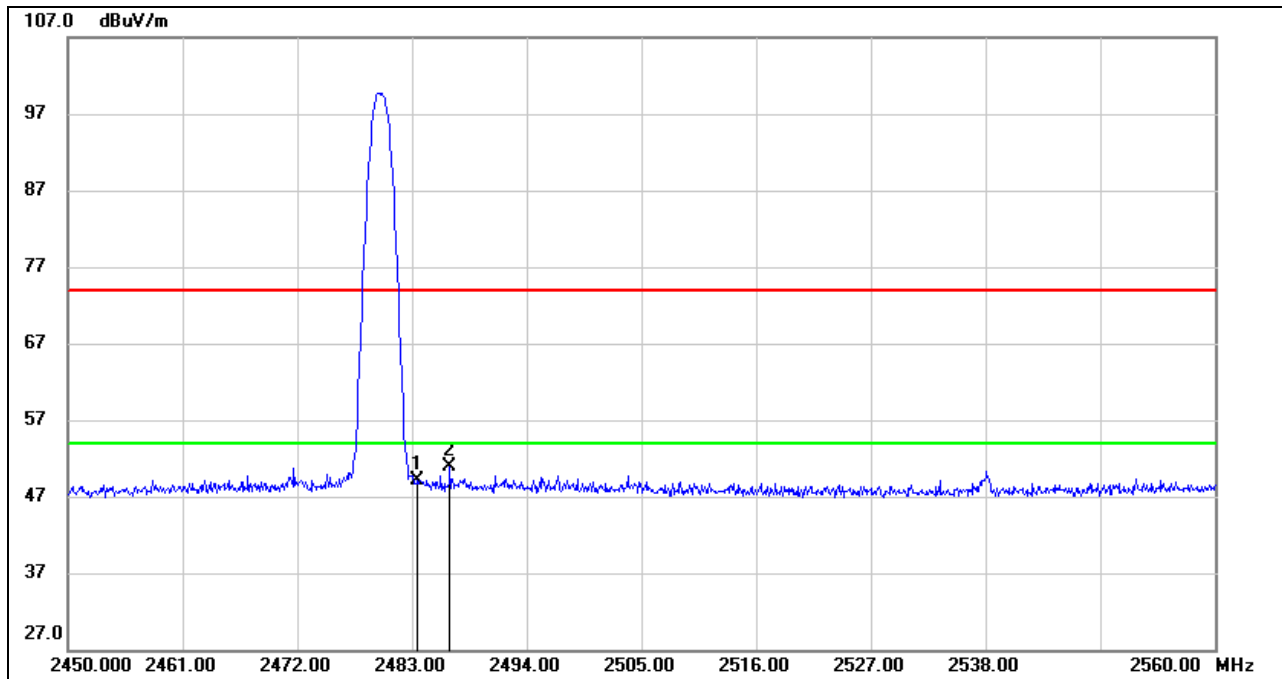

No.	Frequency (MHz)	Reading (dBuV/m)	Correct dB/m	Result (dBuV/m)	Limit (dBuV/m)	Margin (dB)	Remark
1	2483.500	16.23	32.88	49.11	74.00	-24.89	peak
2	2486.630	18.10	32.89	50.99	74.00	-23.01	peak

- Note:
1. Measurement = Reading Level + Correct Factor.
  2. If Peak Result complies with AV limit, AV Result is deemed to comply with AV limit.
  3. Peak: Peak detector.
  4. AVG: VBW=1/Ton where: ton is transmit duration.
  5. For transmit duration, please refer to clause 6.1.

### 7.2.2. 8DPSK MODE

#### ANTENNA1 (WORST-CASE CONFIGURATION)

#### RESTRICTED BANDEDGE (LOW CHANNEL, HORIZONTAL)

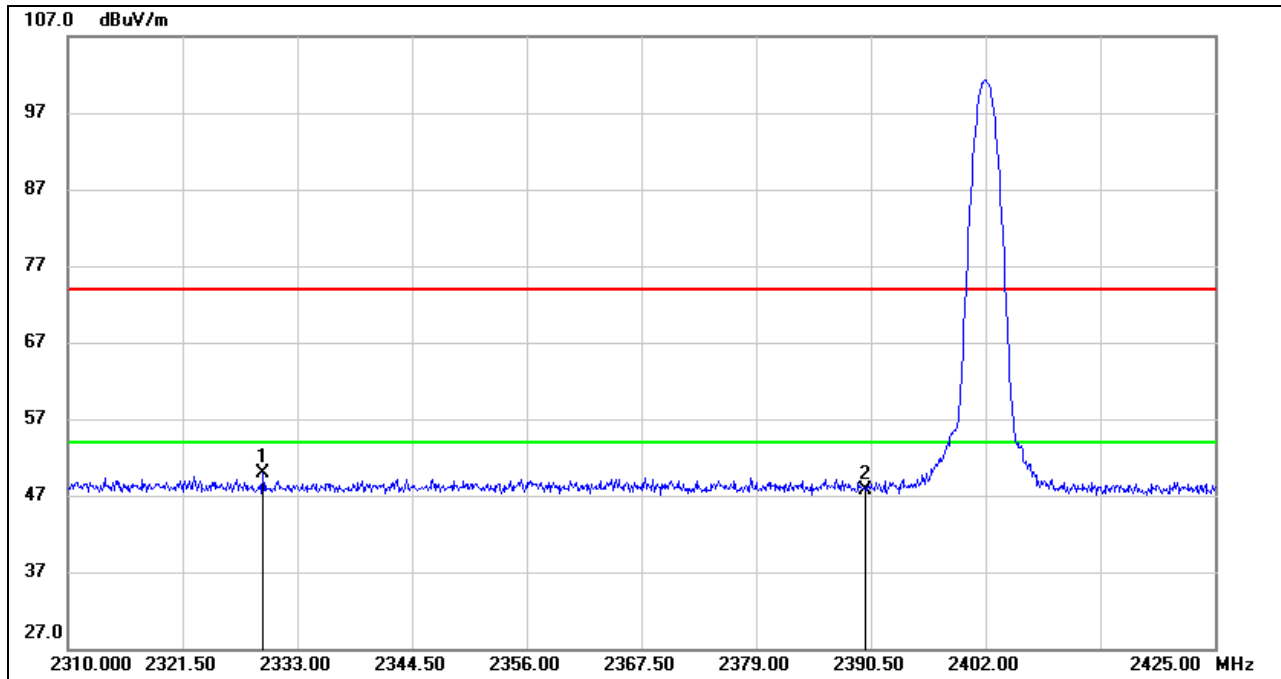

No.	Frequency (MHz)	Reading (dBuV/m)	Correct (dB/m)	Result (dBuV/m)	Limit (dBuV/m)	Margin (dB)	Remark
1	2329.550	16.39	33.57	49.96	74.00	-24.04	peak
2	2390.000	14.51	33.14	47.65	74.00	-26.35	peak

- Note: 1. Measurement = Reading Level + Correct Factor.  
 2. If Peak Result complies with AV limit, AV Result is deemed to comply with AV limit.  
 3. Peak: Peak detector.  
 4. AVG: VBW=1/Ton where: ton is transmit duration.  
 5. For transmit duration, please refer to clause 6.1.

**RESTRICTED BANDEDGE (LOW CHANNEL, VERTICAL)**

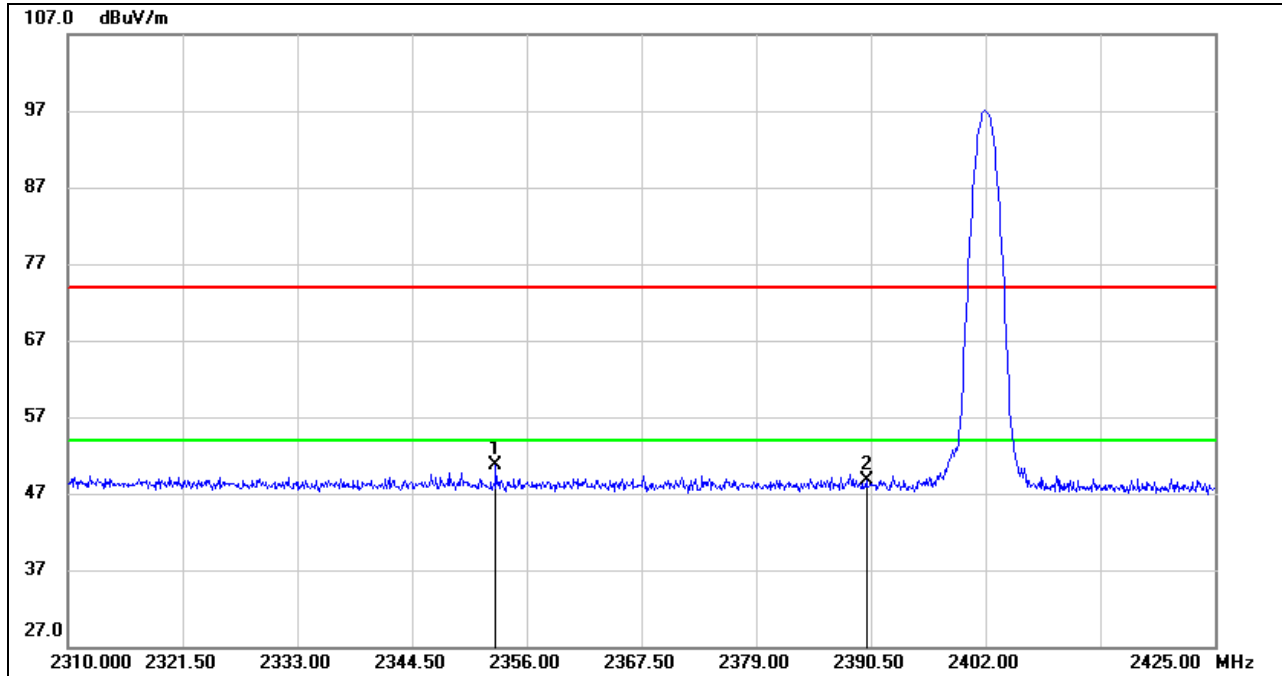

No.	Frequency (MHz)	Reading (dBuV/m)	Correct dB/m	Result (dBuV/m)	Limit (dBuV/m)	Margin (dB)	Remark
1	2352.895	17.22	33.51	50.73	74.00	-23.27	peak
2	2390.000	15.37	33.24	48.61	74.00	-25.39	peak

- Note: 1. Measurement = Reading Level + Correct Factor.  
 2. If Peak Result complies with AV limit, AV Result is deemed to comply with AV limit.  
 3. Peak: Peak detector.  
 4. AVG: VBW=1/Ton where: ton is transmit duration.  
 5. For transmit duration, please refer to clause 6.1.

**RESTRICTED BANDEDGE (HIGH CHANNEL, HORIZONTAL)**

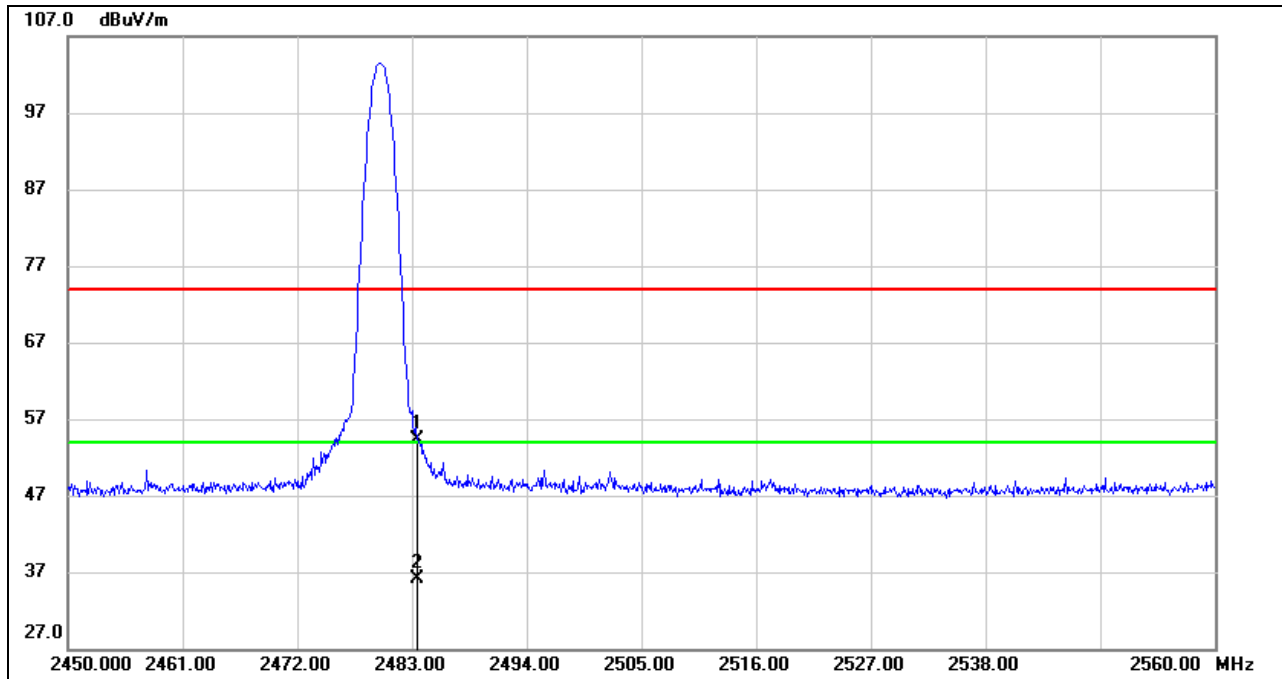

No.	Frequency (MHz)	Reading (dBuV/m)	Correct dB/m	Result (dBuV/m)	Limit (dBuV/m)	Margin (dB)	Remark
1	2483.500	21.55	32.78	54.33	74.00	-19.67	peak
2	2483.500	3.29	32.78	36.07	54.00	-17.93	AVG

- Note: 1. Measurement = Reading Level + Correct Factor.  
 2. If Peak Result complies with AV limit, AV Result is deemed to comply with AV limit.  
 3. Peak: Peak detector.  
 4. AVG: VBW=1/Ton where: ton is transmit duration.  
 5. For transmit duration, please refer to clause 6.1.

**RESTRICTED BANDEDGE (HIGH CHANNEL, VERTICAL)**

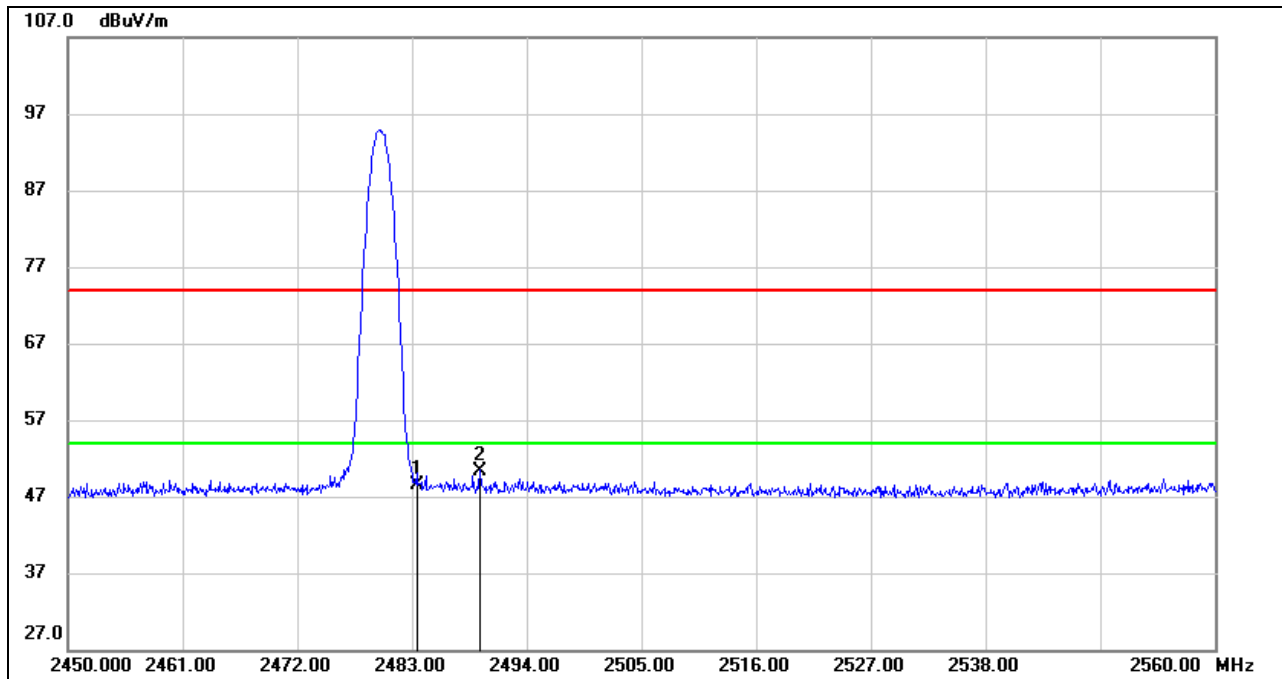

No.	Frequency (MHz)	Reading (dBuV/m)	Correct dB/m	Result (dBuV/m)	Limit (dBuV/m)	Margin (dB)	Remark
1	2483.500	15.59	32.88	48.47	74.00	-25.53	peak
2	2489.490	17.52	32.88	50.40	74.00	-23.60	peak

- Note:
1. Measurement = Reading Level + Correct Factor.
  2. If Peak Result complies with AV limit, AV Result is deemed to comply with AV limit.
  3. Peak: Peak detector.
  4. AVG:  $VBW=1/Ton$  where: ton is transmit duration.
  5. For transmit duration, please refer to clause 6.1.

### 7.3. SPURIOUS EMISSIONS (1~18GHz)

#### 7.3.1. GFSK MODE

##### ANTENNA1 (WORST-CASE CONFIGURATION)

##### HARMONICS AND SPURIOUS EMISSIONS (LOW CHANNEL, HORIZONTAL)

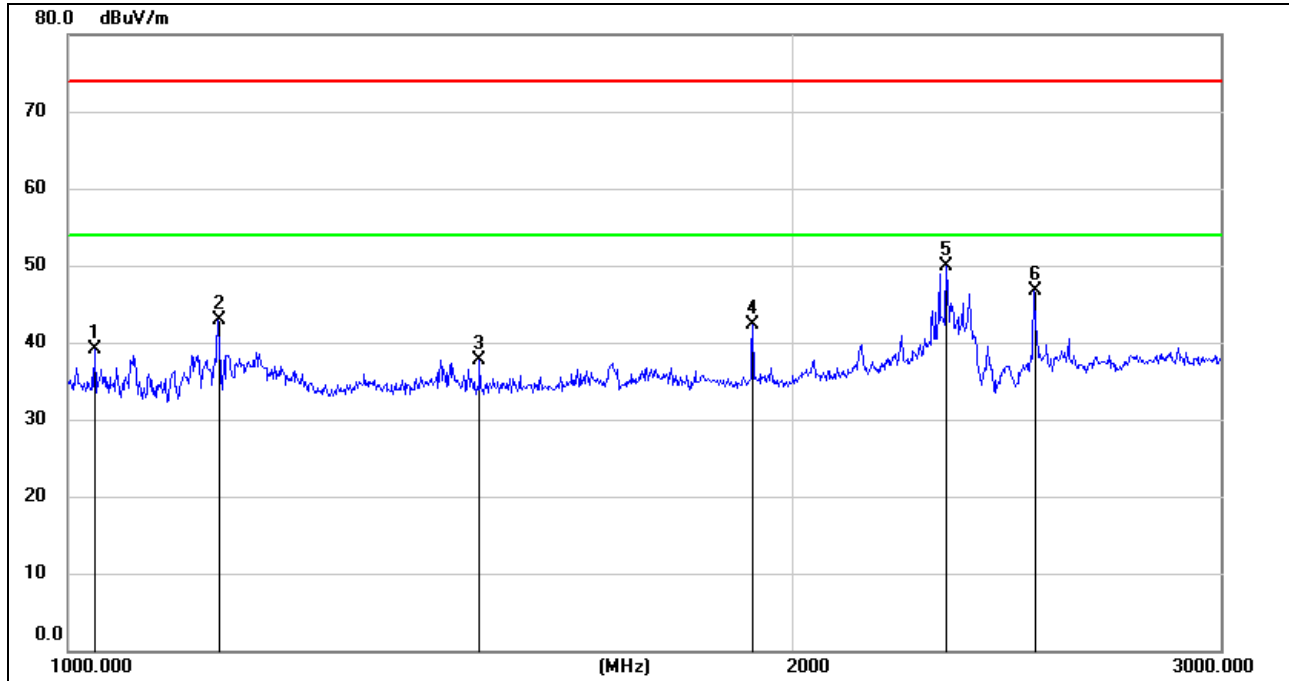

No.	Frequency (MHz)	Reading (dBuV/m)	Correct dB/m	Result (dBuV/m)	Limit (dBuV/m)	Margin (dB)	Remark
1	1025.590	52.93	-13.91	39.02	74.00	-34.98	peak
2	1154.790	56.29	-13.34	42.95	74.00	-31.05	peak
3	1480.241	49.96	-12.22	37.74	74.00	-36.26	peak
4	1920.481	53.05	-10.72	42.33	74.00	-31.67	peak
5	2312.296	57.47	-7.48	49.99	74.00	-24.01	peak
6	2513.650	54.99	-8.38	46.61	74.00	-27.39	peak

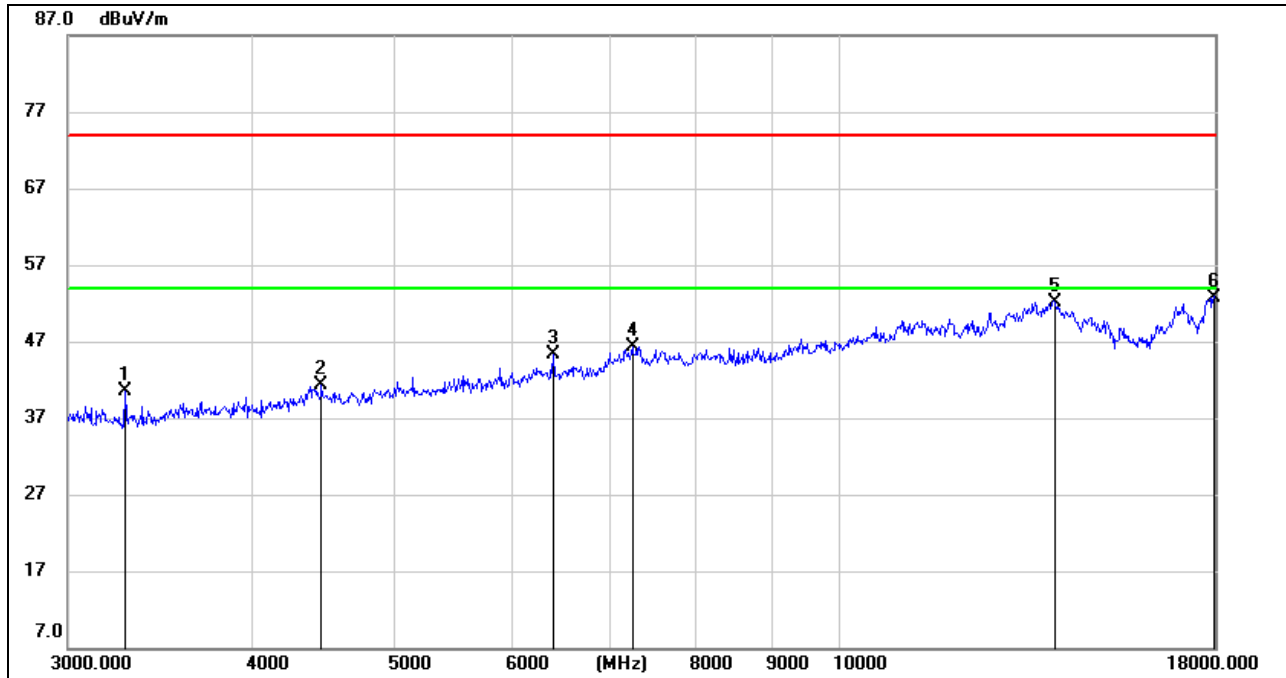

No.	Frequency (MHz)	Reading (dBuV/m)	Correct dB/m	Result (dBuV/m)	Limit (dBuV/m)	Margin (dB)	Remark
1	3281.171	45.45	-4.86	40.59	74.00	-33.41	peak
2	4457.514	42.04	-0.83	41.21	74.00	-32.79	peak
3	6401.463	40.67	4.66	45.33	74.00	-28.67	peak
4	7243.887	38.56	7.84	46.40	74.00	-27.60	peak
5	14006.555	31.59	20.61	52.20	74.00	-21.80	peak
6	17967.777	25.76	27.04	52.80	74.00	-21.20	peak

- Note: 1. Measurement = Reading Level + Correct Factor.  
 2. If Peak Result complies with AV limit, AV Result is deemed to comply with AV limit.  
 3. Peak: Peak detector.  
 4. AVG: VBW=1/Ton where: ton is transmit duration.  
 5. For transmit duration, please refer to clause 6.1.

**HARMONICS AND SPURIOUS EMISSIONS (LOW CHANNEL, VERTICAL)**

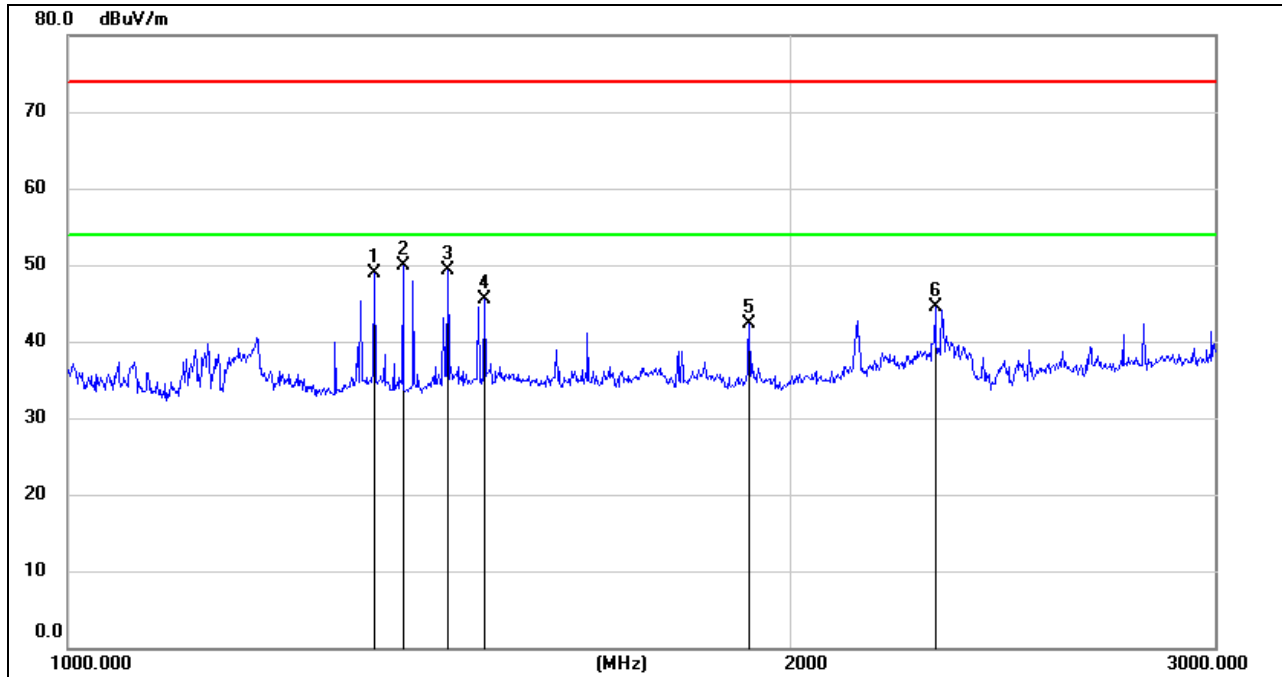

No.	Frequency (MHz)	Reading (dBuV/m)	Correct dB/m	Result (dBuV/m)	Limit (dBuV/m)	Margin (dB)	Remark
1	1340.885	61.31	-12.43	48.88	74.00	-25.12	peak
2	1378.223	62.23	-12.42	49.81	74.00	-24.19	peak
3	1438.557	61.54	-12.31	49.23	74.00	-24.77	peak
4	1490.030	57.74	-12.28	45.46	74.00	-28.54	peak
5	1920.481	53.05	-10.82	42.23	74.00	-31.77	peak
6	2297.105	51.75	-7.23	44.52	74.00	-29.48	peak

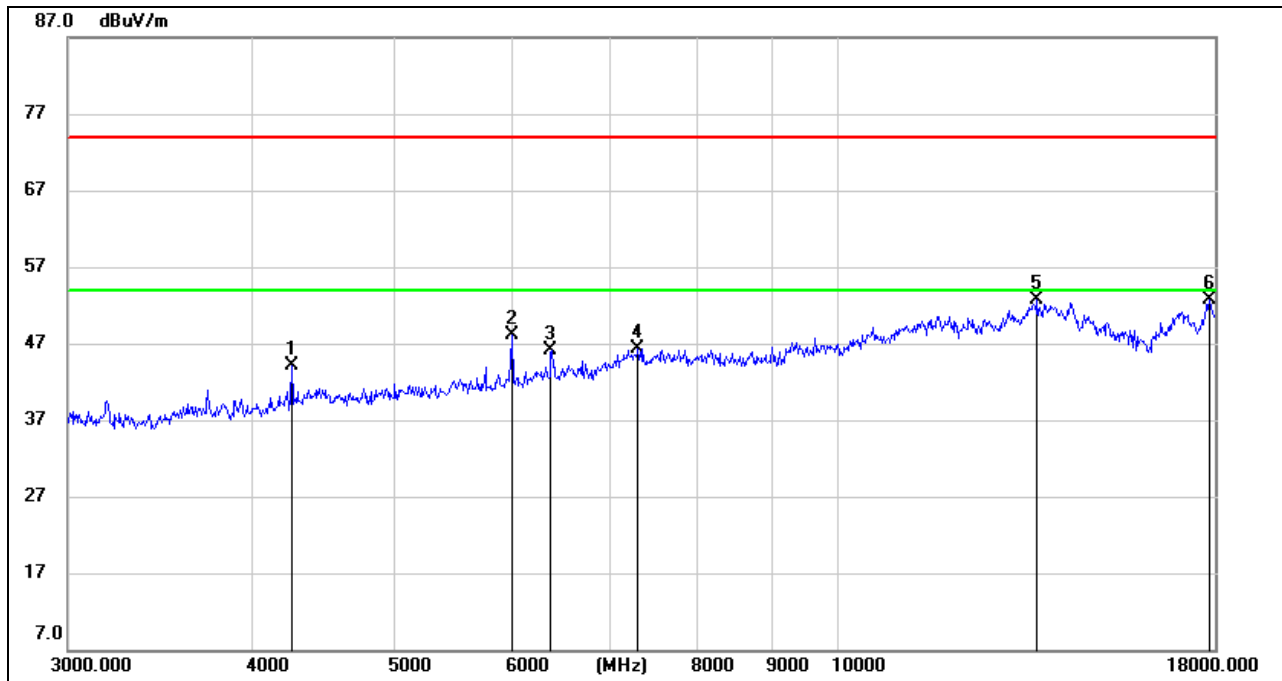

No.	Frequency (MHz)	Reading (dBuV/m)	Correct dB/m	Result (dBuV/m)	Limit (dBuV/m)	Margin (dB)	Remark
1	4254.620	45.90	-1.85	44.05	74.00	-29.95	peak
2	6001.583	44.80	3.32	48.12	74.00	-25.88	peak
3	6390.003	41.43	4.73	46.16	74.00	-27.84	peak
4	7309.075	38.52	7.77	46.29	74.00	-27.71	peak
5	13635.123	31.99	20.62	52.61	74.00	-21.39	peak
6	17839.462	26.50	26.26	52.76	74.00	-21.24	peak

- Note: 1. Measurement = Reading Level + Correct Factor.  
 2. If Peak Result complies with AV limit, AV Result is deemed to comply with AV limit.  
 3. Peak: Peak detector.  
 4. AVG: VBW=1/Ton where: ton is transmit duration.  
 5. For transmit duration, please refer to clause 6.1.

**HARMONICS AND SPURIOUS EMISSIONS (MID CHANNEL, HORIZONTAL)**

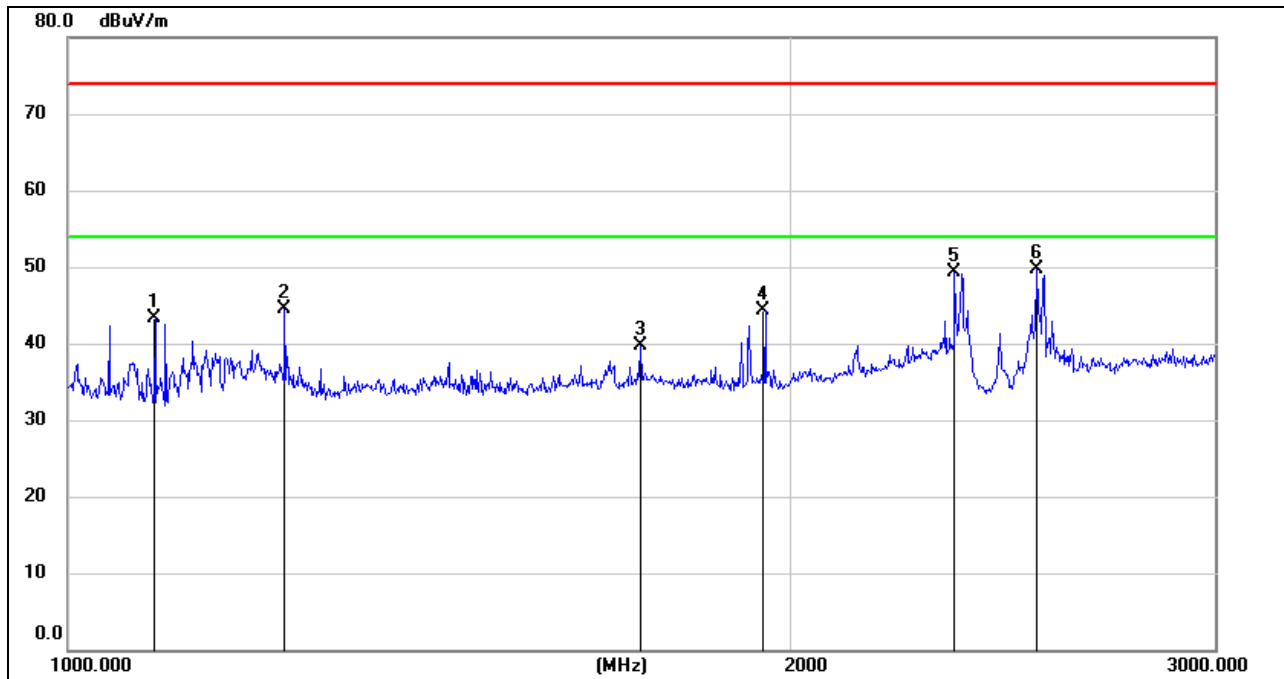

No.	Frequency (MHz)	Reading (dBuV/m)	Correct dB/m	Result (dBuV/m)	Limit (dBuV/m)	Margin (dB)	Remark
1	1087.079	56.91	-13.58	43.33	74.00	-30.67	peak
2	1230.767	57.33	-12.92	44.41	74.00	-29.59	peak
3	1730.149	51.05	-11.37	39.68	74.00	-34.32	peak
4	1950.247	55.04	-10.68	44.36	74.00	-29.64	peak
5	2337.840	56.90	-7.66	49.24	74.00	-24.76	peak
6	2533.055	58.13	-8.37	49.76	74.00	-24.24	peak

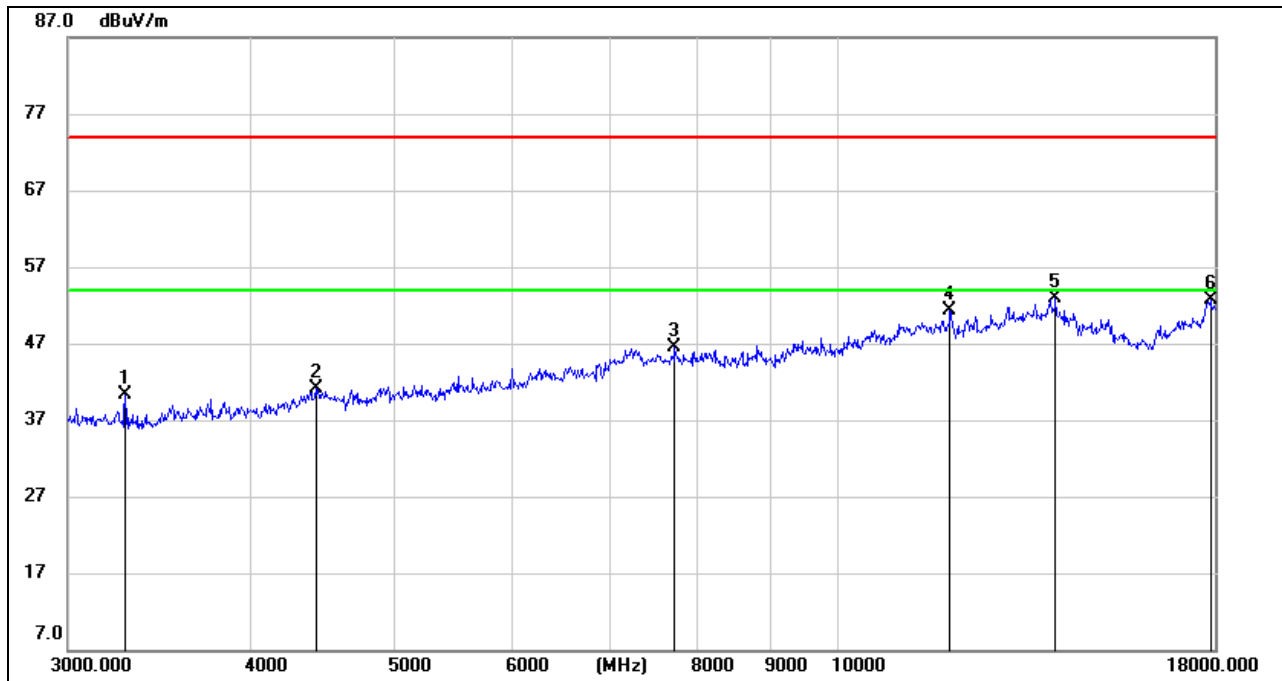

No.	Frequency (MHz)	Reading (dBuV/m)	Correct dB/m	Result (dBuV/m)	Limit (dBuV/m)	Margin (dB)	Remark
1	3281.171	45.14	-4.86	40.28	74.00	-33.72	peak
2	4417.758	41.93	-0.88	41.05	74.00	-32.95	peak
3	7740.398	38.36	8.11	46.47	74.00	-27.53	peak
4	11920.589	34.54	16.81	51.35	74.00	-22.65	peak
5	14031.674	32.19	20.63	52.82	74.00	-21.18	peak
6	17871.455	26.36	26.36	52.72	74.00	-21.28	peak

- Note: 1. Measurement = Reading Level + Correct Factor.  
 2. If Peak Result complies with AV limit, AV Result is deemed to comply with AV limit.  
 3. Peak: Peak detector.  
 4. AVG: VBW=1/Ton where: ton is transmit duration.  
 5. For transmit duration, please refer to clause 6.1.

**HARMONICS AND SPURIOUS EMISSIONS (MID CHANNEL, VERTICAL)**

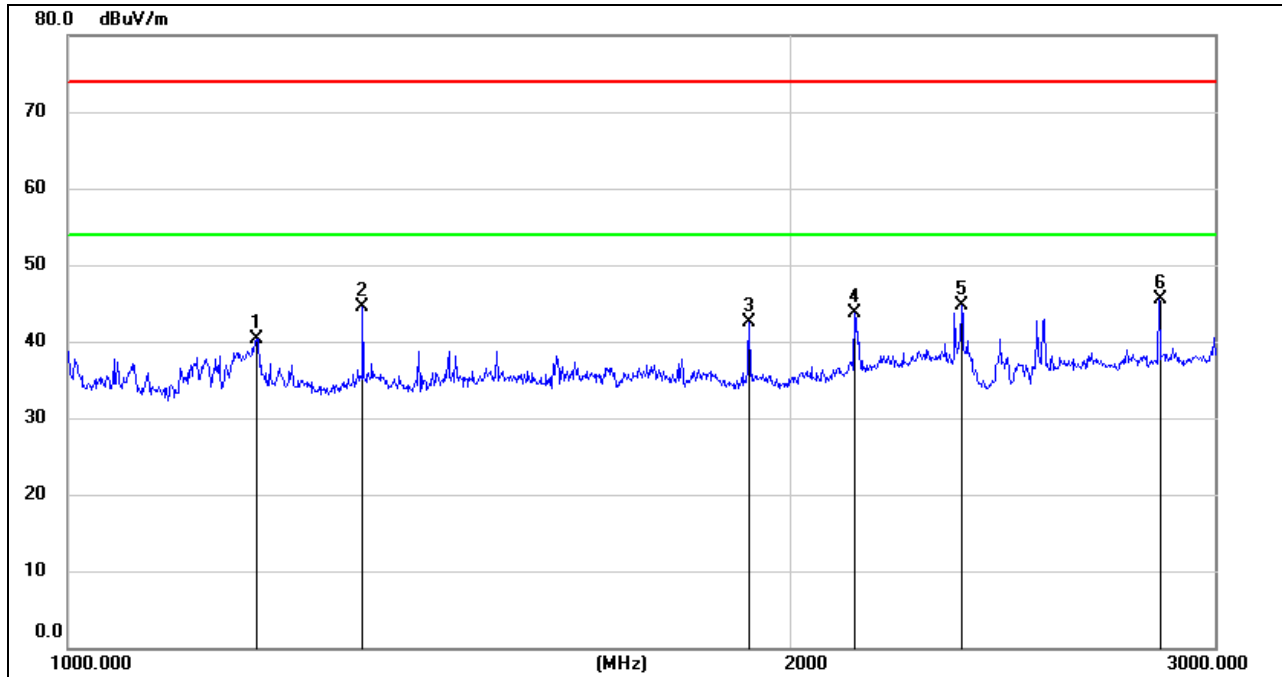

No.	Frequency (MHz)	Reading (dBuV/m)	Correct dB/m	Result (dBuV/m)	Limit (dBuV/m)	Margin (dB)	Remark
1	1198.740	53.46	-13.18	40.28	74.00	-33.72	peak
2	1326.234	57.06	-12.53	44.53	74.00	-29.47	peak
3	1920.481	53.40	-10.82	42.58	74.00	-31.42	peak
4	2124.737	53.02	-9.35	43.67	74.00	-30.33	peak
5	2355.888	52.41	-7.69	44.72	74.00	-29.28	peak
6	2845.899	52.28	-6.72	45.56	74.00	-28.44	peak

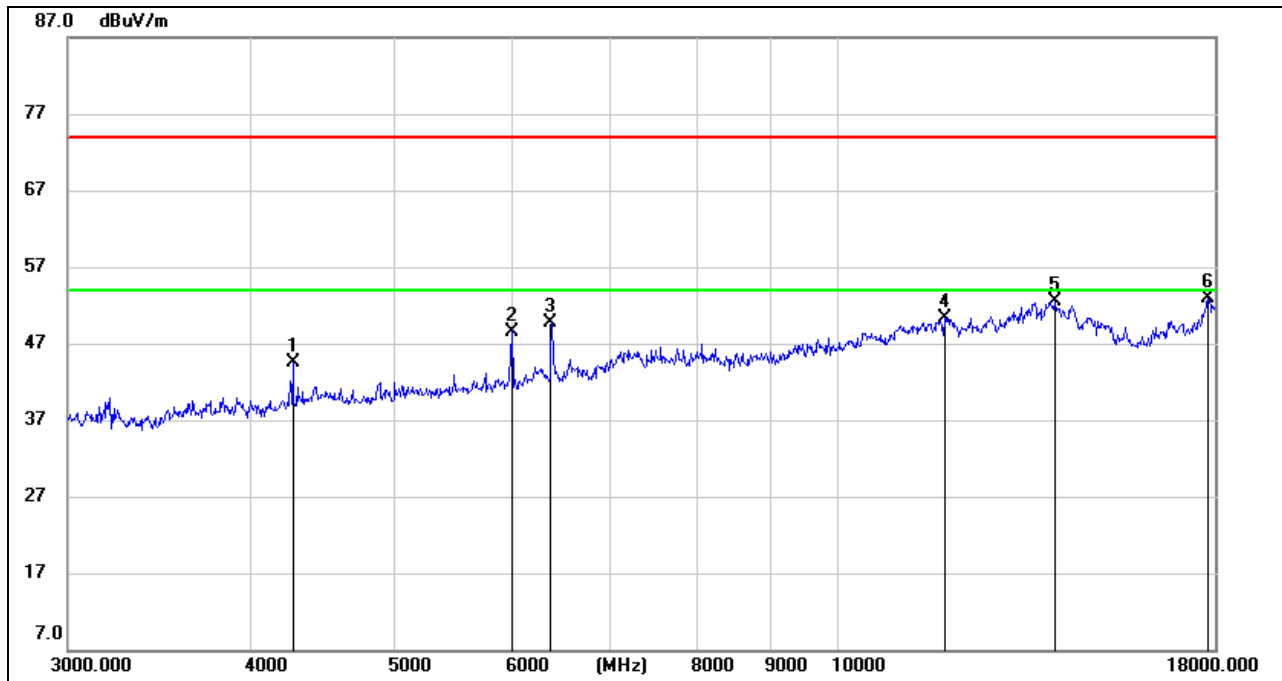

No.	Frequency (MHz)	Reading (dBuV/m)	Correct dB/m	Result (dBuV/m)	Limit (dBuV/m)	Margin (dB)	Remark
1	4262.250	46.35	-1.78	44.57	74.00	-29.43	peak
2	6001.583	45.28	3.32	48.60	74.00	-25.40	peak
3	6390.003	45.06	4.73	49.79	74.00	-24.21	peak
4	11793.123	33.91	16.45	50.36	74.00	-23.64	peak
5	14031.674	31.92	20.61	52.53	74.00	-21.47	peak
6	17807.526	26.24	26.76	53.00	74.00	-21.00	peak

- Note: 1. Measurement = Reading Level + Correct Factor.  
 2. If Peak Result complies with AV limit, AV Result is deemed to comply with AV limit.  
 3. Peak: Peak detector.  
 4. AVG: VBW=1/Ton where: ton is transmit duration.  
 5. For transmit duration, please refer to clause 6.1.

**HARMONICS AND SPURIOUS EMISSIONS (HIGH CHANNEL, HORIZONTAL)**

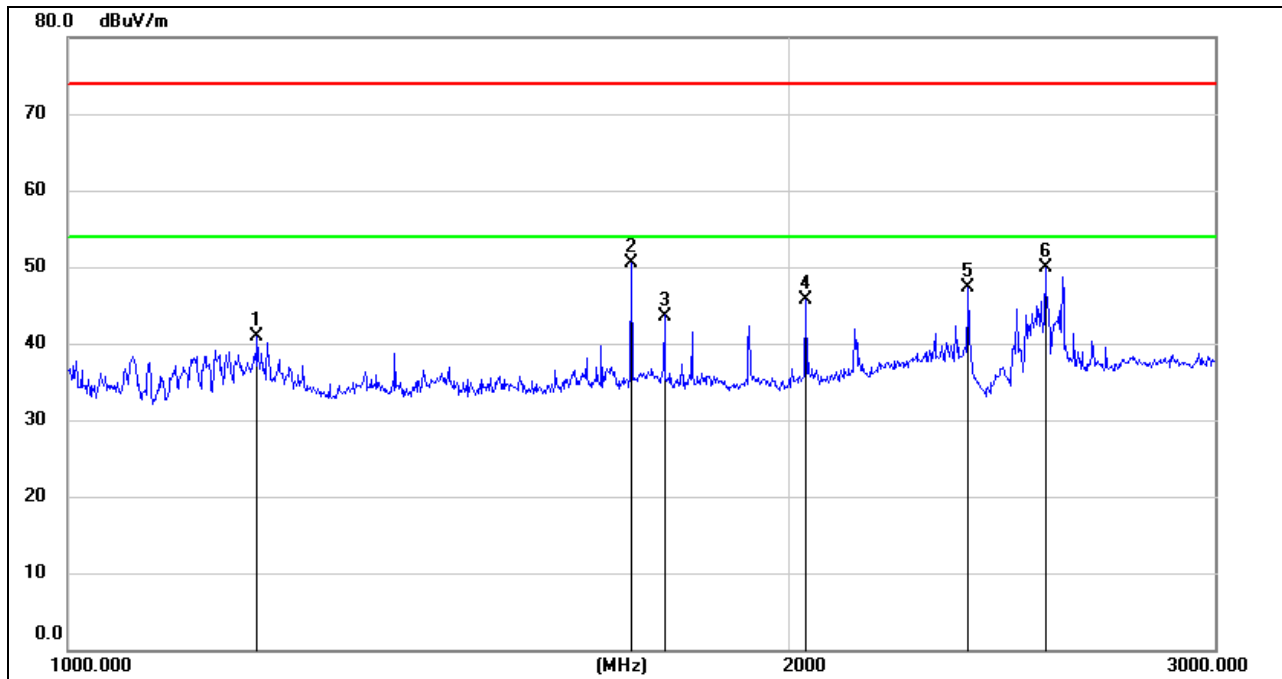

No.	Frequency (MHz)	Reading (dBuV/m)	Correct dB/m	Result (dBuV/m)	Limit (dBuV/m)	Margin (dB)	Remark
1	1198.740	54.03	-13.08	40.95	74.00	-33.05	peak
2	1715.010	61.95	-11.45	50.50	74.00	-23.50	peak
3	1770.529	54.82	-11.22	43.60	74.00	-30.40	peak
4	2026.698	56.12	-10.40	45.72	74.00	-28.28	peak
5	2368.864	55.25	-7.89	47.36	74.00	-26.64	peak
6	2549.807	58.18	-8.35	49.83	74.00	-24.17	peak

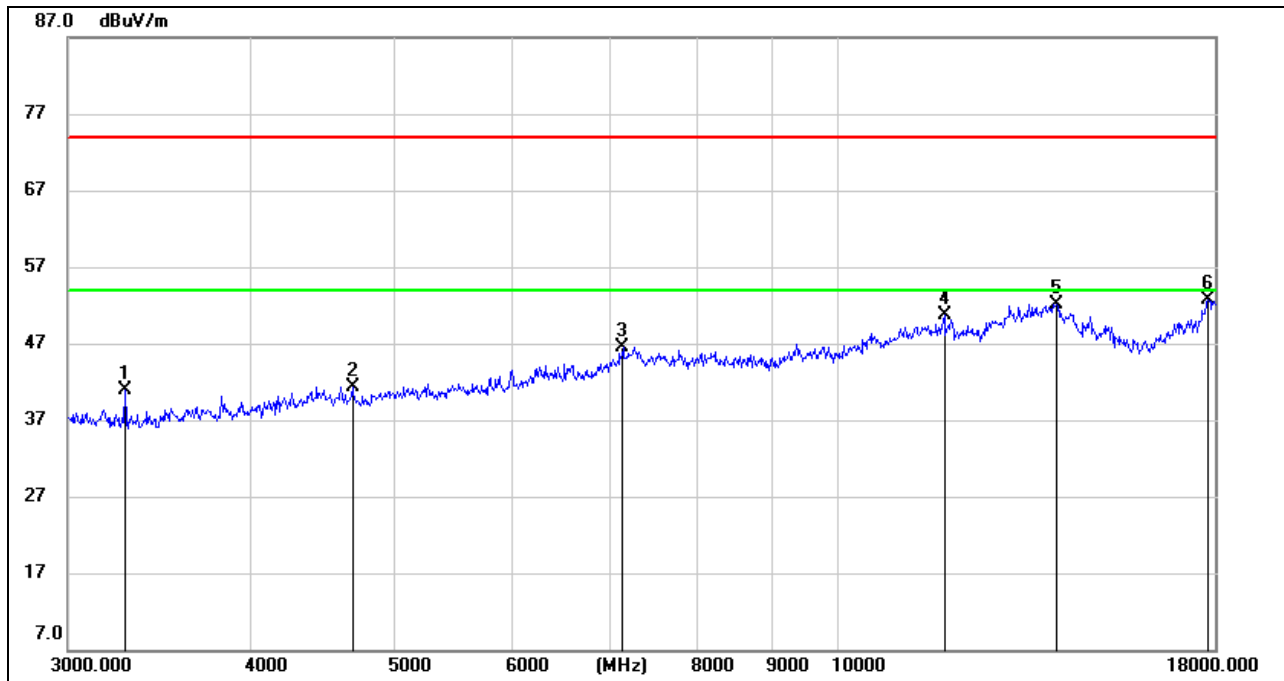

No.	Frequency (MHz)	Reading (dBuV/m)	Correct dB/m	Result (dBuV/m)	Limit (dBuV/m)	Margin (dB)	Remark
1	3281.171	45.75	-4.86	40.89	74.00	-33.11	peak
2	4678.458	42.01	-0.65	41.36	74.00	-32.64	peak
3	7140.793	38.86	7.62	46.48	74.00	-27.52	peak
4	11793.123	34.99	15.68	50.67	74.00	-23.33	peak
5	14056.838	31.50	20.64	52.14	74.00	-21.86	peak
6	17807.526	26.12	26.49	52.61	74.00	-21.39	peak

- Note: 1. Measurement = Reading Level + Correct Factor.  
 2. If Peak Result complies with AV limit, AV Result is deemed to comply with AV limit.  
 3. Peak: Peak detector.  
 4. AVG: VBW=1/Ton where: ton is transmit duration.  
 5. For transmit duration, please refer to clause 6.1.

**HARMONICS AND SPURIOUS EMISSIONS (HIGH CHANNEL, VERTICAL)**

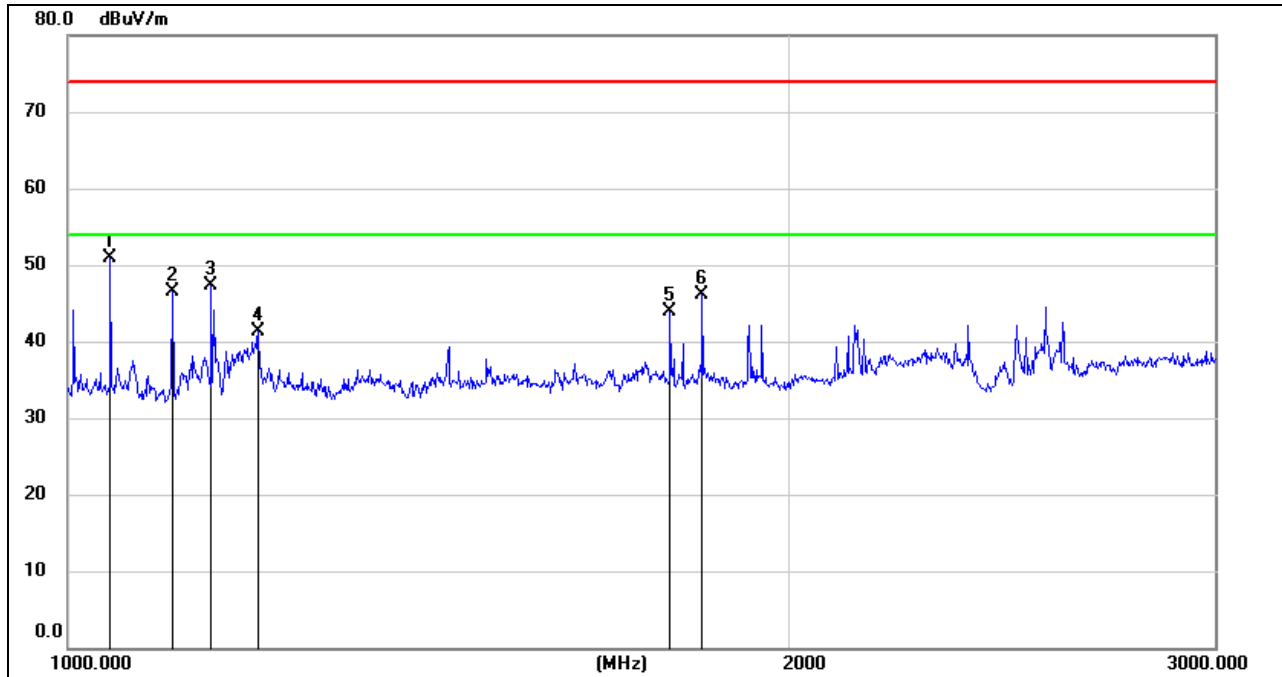

No.	Frequency (MHz)	Reading (dBuV/m)	Correct dB/m	Result (dBuV/m)	Limit (dBuV/m)	Margin (dB)	Remark
1	1041.486	64.81	-13.95	50.86	74.00	-23.14	peak
2	1106.357	60.27	-13.82	46.45	74.00	-27.55	peak
3	1147.203	60.87	-13.58	47.29	74.00	-26.71	peak
4	1200.058	54.53	-13.17	41.36	74.00	-32.64	peak
5	1780.281	55.08	-11.19	43.89	74.00	-30.11	peak
6	1835.896	57.12	-10.95	46.17	74.00	-27.83	peak

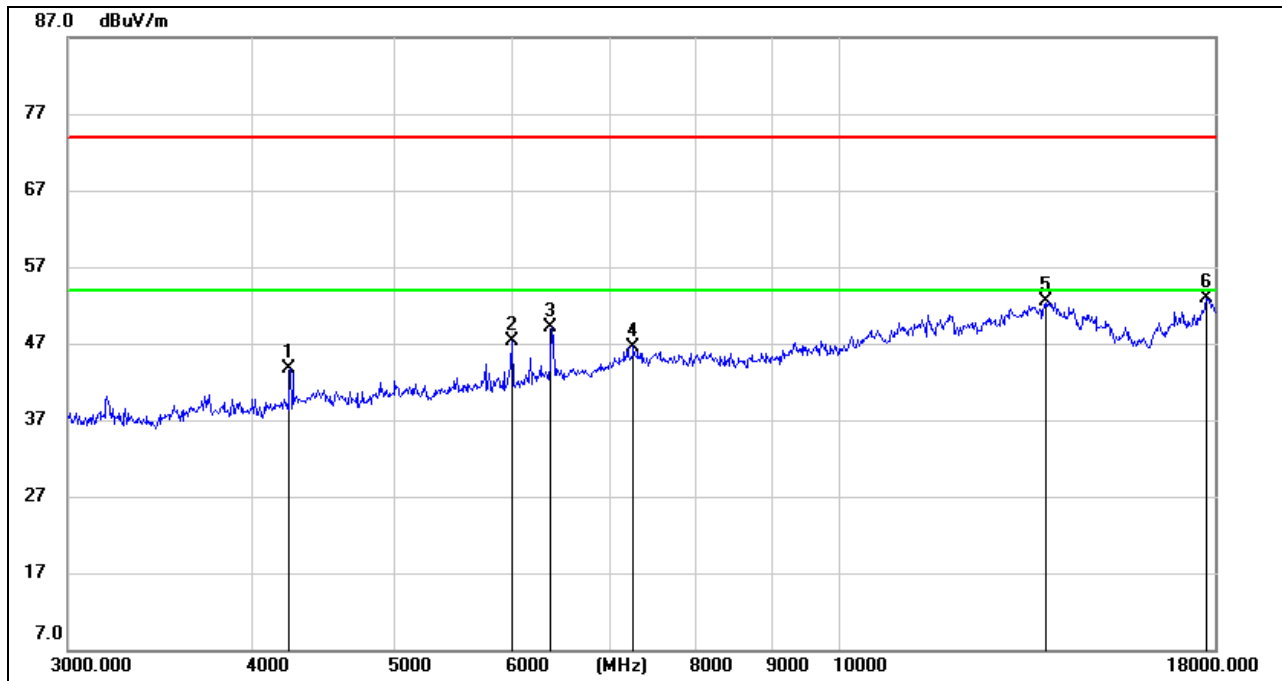

No.	Frequency (MHz)	Reading (dBuV/m)	Correct dB/m	Result (dBuV/m)	Limit (dBuV/m)	Margin (dB)	Remark
1	4247.003	45.54	-1.90	43.64	74.00	-30.36	peak
2	6001.583	44.04	3.32	47.36	74.00	-26.64	peak
3	6390.003	44.33	4.73	49.06	74.00	-24.94	peak
4	7256.878	38.83	7.77	46.60	74.00	-27.40	peak
5	13881.633	31.57	20.87	52.44	74.00	-21.56	peak
6	17743.827	26.78	26.19	52.97	74.00	-21.03	peak

- Note: 1. Measurement = Reading Level + Correct Factor.  
 2. If Peak Result complies with AV limit, AV Result is deemed to comply with AV limit.  
 3. Peak: Peak detector.  
 4. AVG: VBW=1/Ton where: ton is transmit duration.  
 5. For transmit duration, please refer to clause 6.1.

### 7.3.2. 8DPSK MODE

#### ANTENNA1 (WORST-CASE CONFIGURATION)

#### HARMONICS AND SPURIOUS EMISSIONS (LOW CHANNEL, HORIZONTAL)

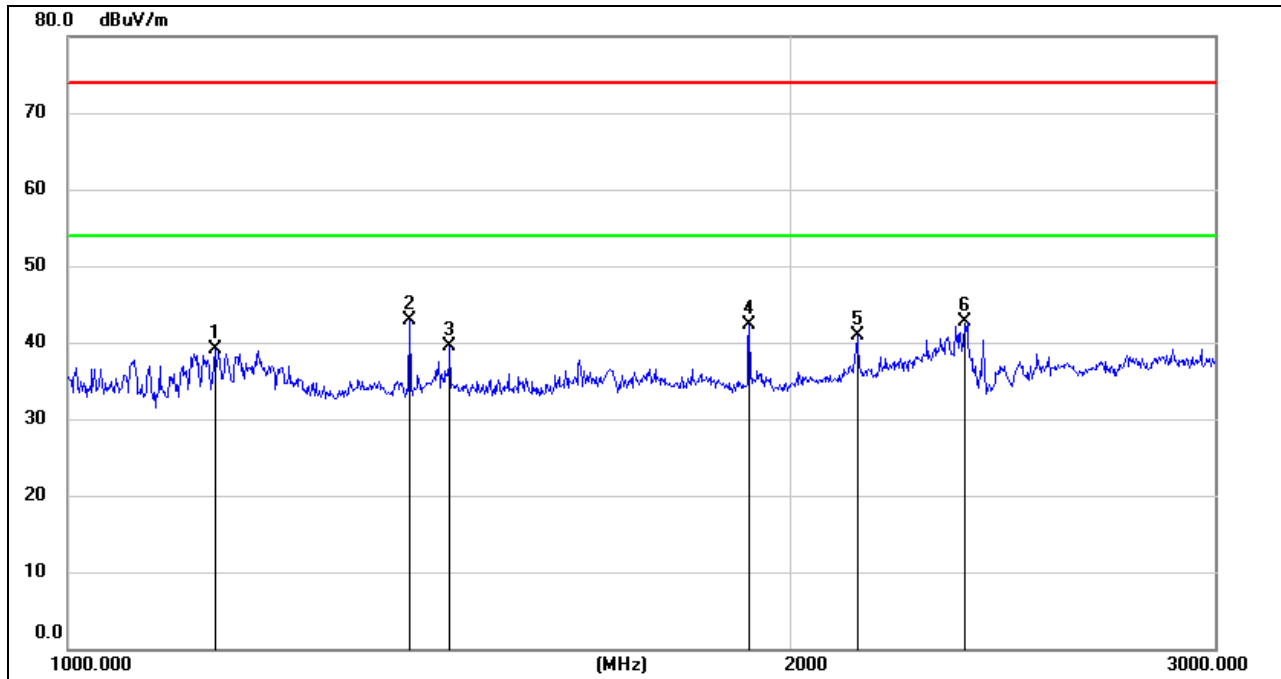

No.	Frequency (MHz)	Reading (dBuV/m)	Correct dB/m	Result (dBuV/m)	Limit (dBuV/m)	Margin (dB)	Remark
1	1150.990	52.42	-13.37	39.05	74.00	-34.95	peak
2	1387.338	55.09	-12.14	42.95	74.00	-31.05	peak
3	1441.722	51.66	-12.23	39.43	74.00	-34.57	peak
4	1920.481	52.94	-10.72	42.22	74.00	-31.78	peak
5	2129.411	50.03	-9.20	40.83	74.00	-33.17	peak
6	2366.263	50.59	-7.87	42.72	74.00	-31.28	peak

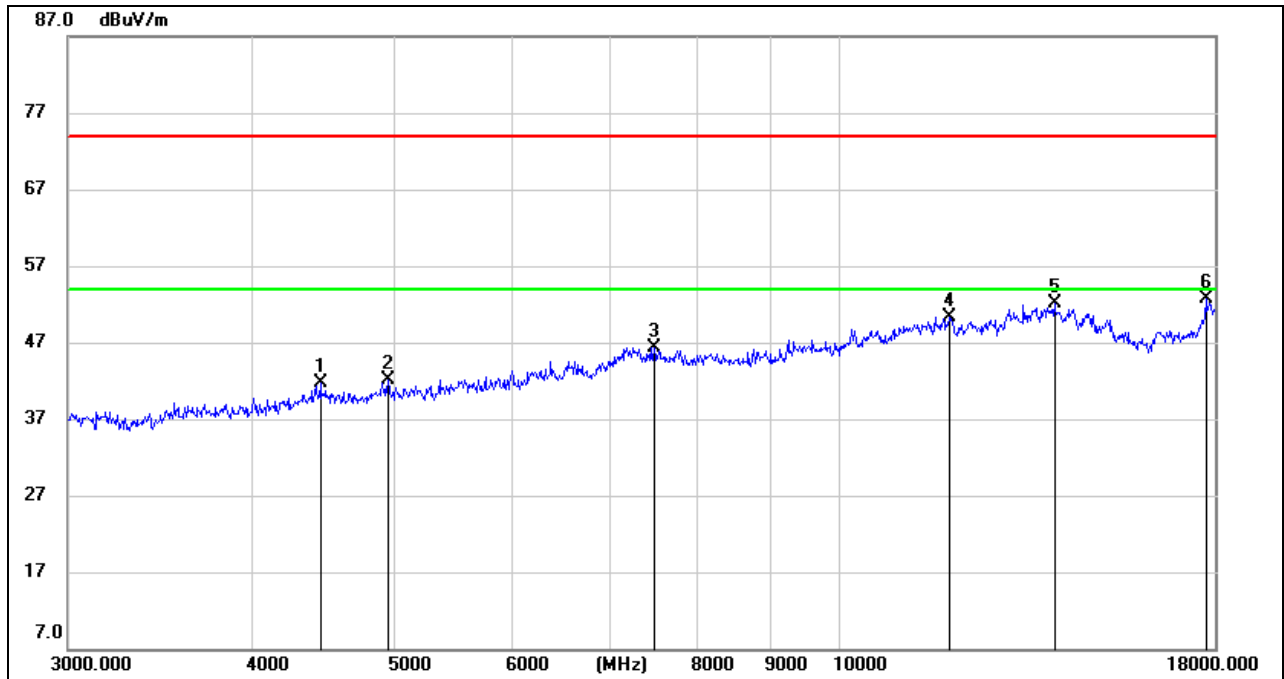

No.	Frequency (MHz)	Reading (dBuV/m)	Correct dB/m	Result (dBuV/m)	Limit (dBuV/m)	Margin (dB)	Remark
1	4449.534	42.50	-0.83	41.67	74.00	-32.33	peak
2	4945.674	41.57	0.60	42.17	74.00	-31.83	peak
3	7494.739	38.24	8.15	46.39	74.00	-27.61	peak
4	11920.589	33.48	16.81	50.29	74.00	-23.71	peak
5	14006.555	31.59	20.61	52.20	74.00	-21.80	peak
6	17743.827	26.77	25.85	52.62	74.00	-21.38	peak

- Note: 1. Measurement = Reading Level + Correct Factor.  
 2. If Peak Result complies with AV limit, AV Result is deemed to comply with AV limit.  
 3. Peak: Peak detector.  
 4. AVG: VBW=1/Ton where: ton is transmit duration.  
 5. For transmit duration, please refer to clause 6.1.

**HARMONICS AND SPURIOUS EMISSIONS (LOW CHANNEL, VERTICAL)**

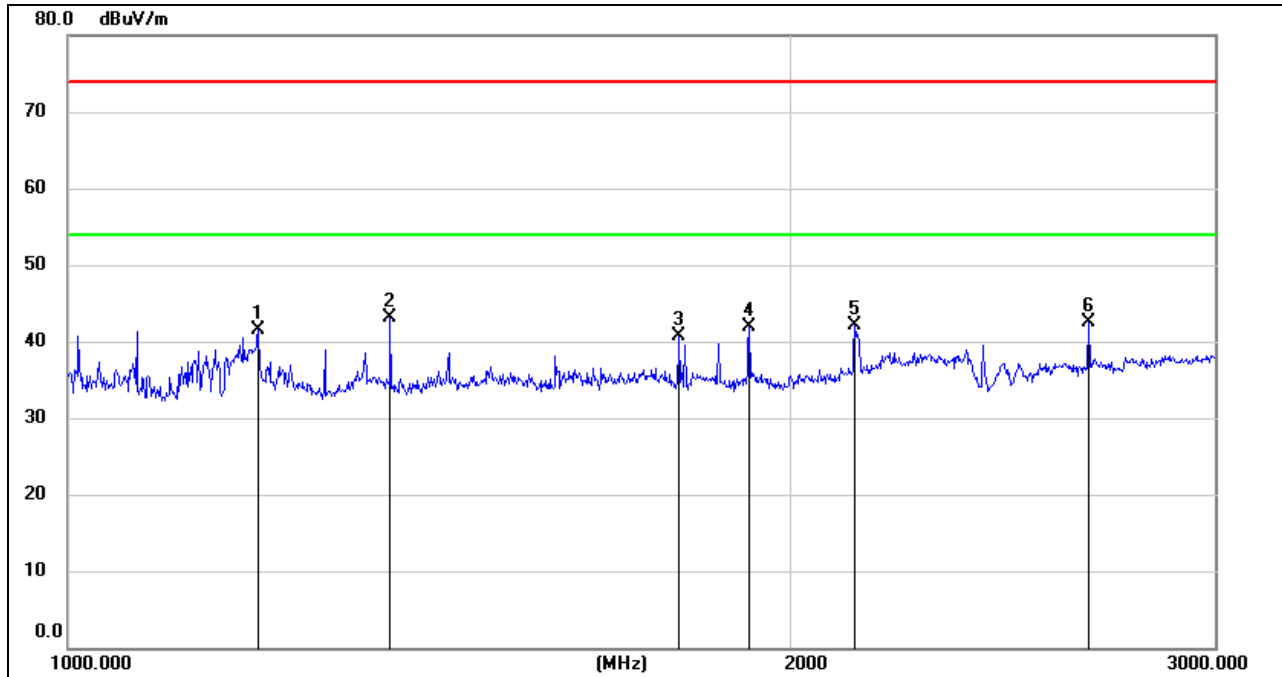

No.	Frequency (MHz)	Reading (dBuV/m)	Correct dB/m	Result (dBuV/m)	Limit (dBuV/m)	Margin (dB)	Remark
1	1200.058	54.66	-13.17	41.49	74.00	-32.51	peak
2	1361.668	55.52	-12.40	43.12	74.00	-30.88	peak
3	1797.971	51.86	-11.13	40.73	74.00	-33.27	peak
4	1920.481	52.68	-10.82	41.86	74.00	-32.14	peak
5	2124.737	51.38	-9.35	42.03	74.00	-31.97	peak
6	2658.508	50.45	-7.89	42.56	74.00	-31.44	peak

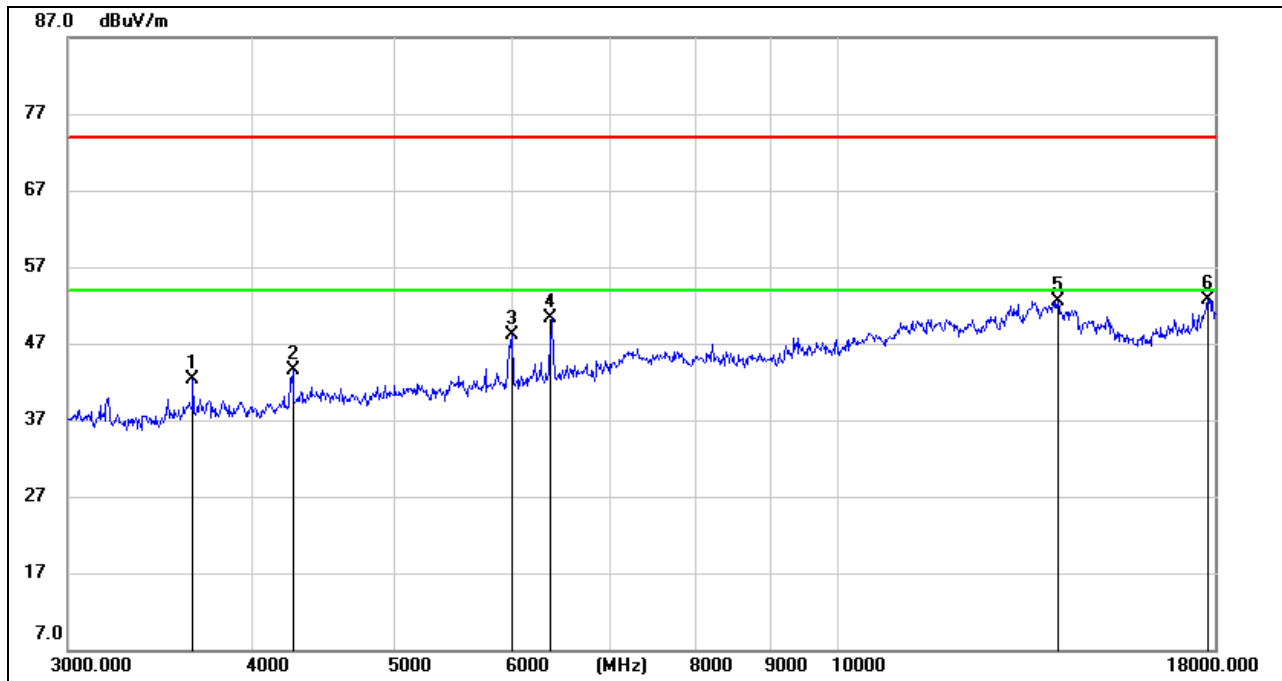

No.	Frequency (MHz)	Reading (dBuV/m)	Correct dB/m	Result (dBuV/m)	Limit (dBuV/m)	Margin (dB)	Remark
1	3647.033	46.23	-3.86	42.37	74.00	-31.63	peak
2	4262.250	45.26	-1.78	43.48	74.00	-30.52	peak
3	6001.583	44.75	3.32	48.07	74.00	-25.93	peak
4	6390.003	45.62	4.73	50.35	74.00	-23.65	peak
5	14082.047	31.95	20.63	52.58	74.00	-21.42	peak
6	17807.526	26.02	26.76	52.78	74.00	-21.22	peak

- Note: 1. Measurement = Reading Level + Correct Factor.  
 2. If Peak Result complies with AV limit, AV Result is deemed to comply with AV limit.  
 3. Peak: Peak detector.  
 4. AVG: VBW=1/Ton where: ton is transmit duration.  
 5. For transmit duration, please refer to clause 6.1.

**HARMONICS AND SPURIOUS EMISSIONS (MID CHANNEL, HORIZONTAL)**

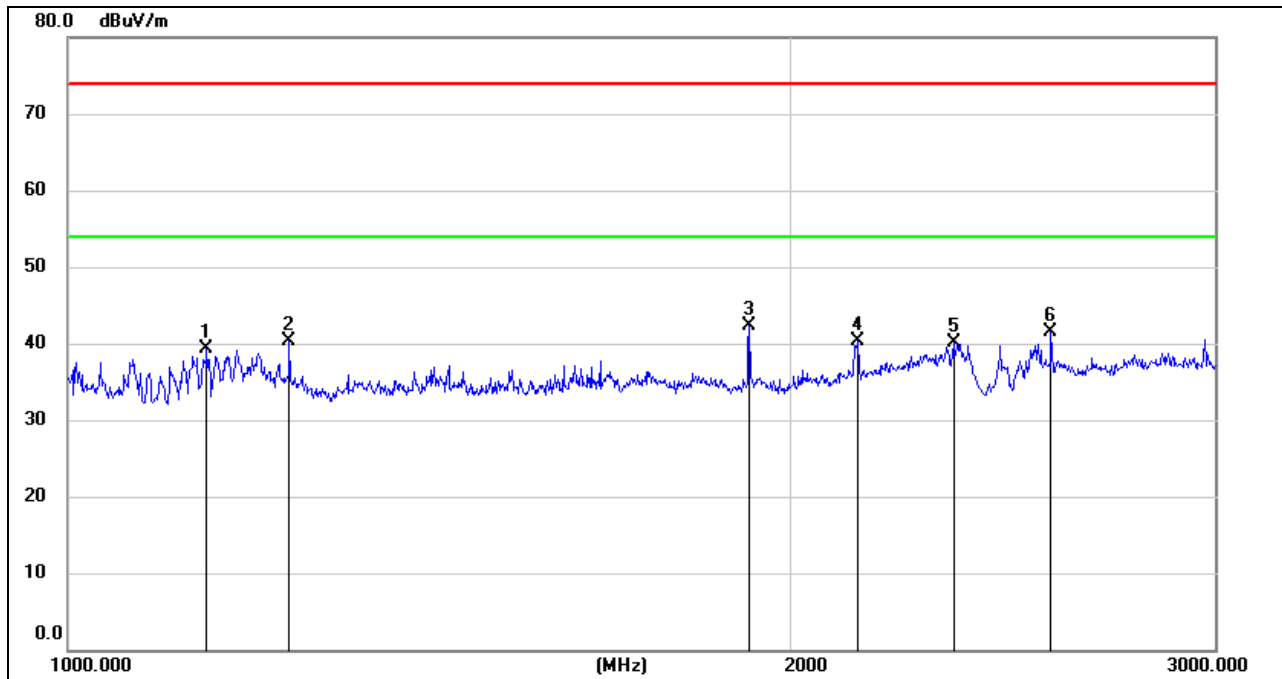

No.	Frequency (MHz)	Reading (dBuV/m)	Correct dB/m	Result (dBuV/m)	Limit (dBuV/m)	Margin (dB)	Remark
1	1142.172	52.64	-13.40	39.24	74.00	-34.76	peak
2	1237.546	53.17	-12.89	40.28	74.00	-33.72	peak
3	1920.481	52.96	-10.72	42.24	74.00	-31.76	peak
4	2131.751	49.41	-9.16	40.25	74.00	-33.75	peak
5	2335.273	47.77	-7.64	40.13	74.00	-33.87	peak
6	2563.852	49.76	-8.28	41.48	74.00	-32.52	peak

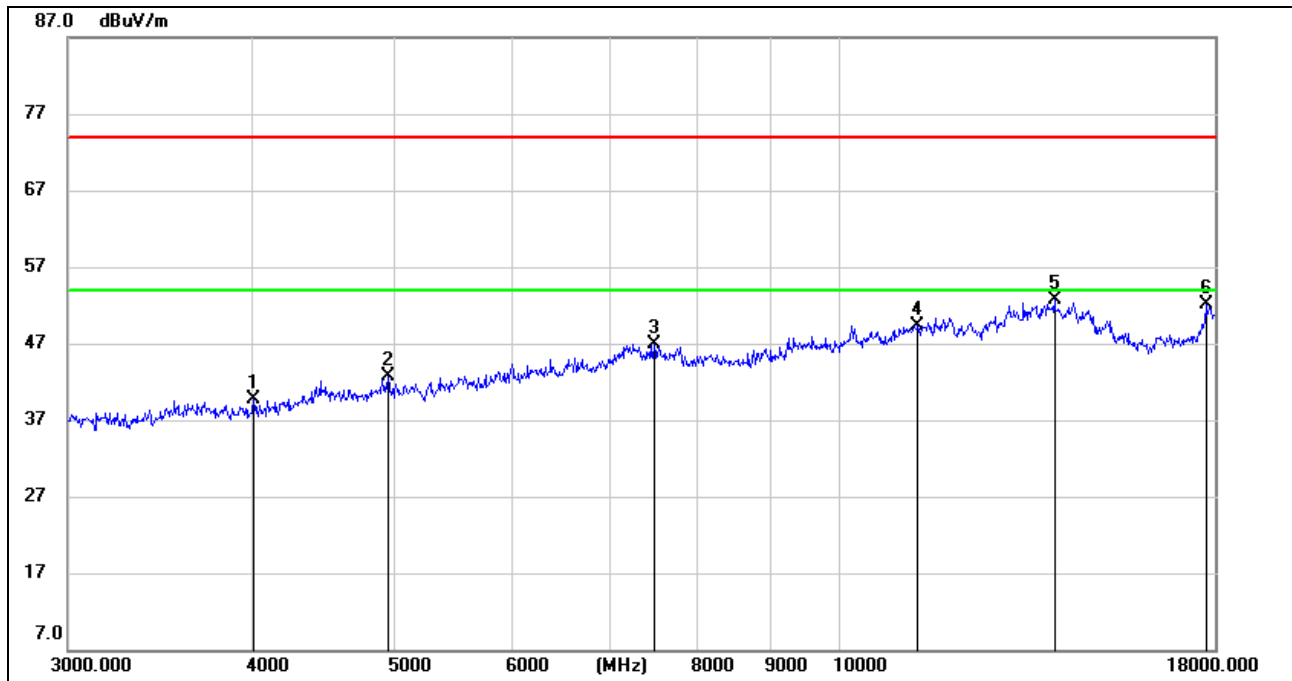

No.	Frequency (MHz)	Reading (dBuV/m)	Correct dB/m	Result (dBuV/m)	Limit (dBuV/m)	Margin (dB)	Remark
1	4010.345	42.72	-2.94	39.78	74.00	-34.22	peak
2	4945.674	42.07	0.60	42.67	74.00	-31.33	peak
3	7494.739	38.74	8.15	46.89	74.00	-27.11	peak
4	11317.000	34.01	15.35	49.36	74.00	-24.64	peak
5	14006.555	32.09	20.61	52.70	74.00	-21.30	peak
6	17743.827	26.27	25.85	52.12	74.00	-21.88	peak

- Note: 1. Measurement = Reading Level + Correct Factor.  
 2. If Peak Result complies with AV limit, AV Result is deemed to comply with AV limit.  
 3. Peak: Peak detector.  
 4. AVG: VBW=1/Ton where: ton is transmit duration.  
 5. For transmit duration, please refer to clause 6.1.

**HARMONICS AND SPURIOUS EMISSIONS (MID CHANNEL, VERTICAL)**

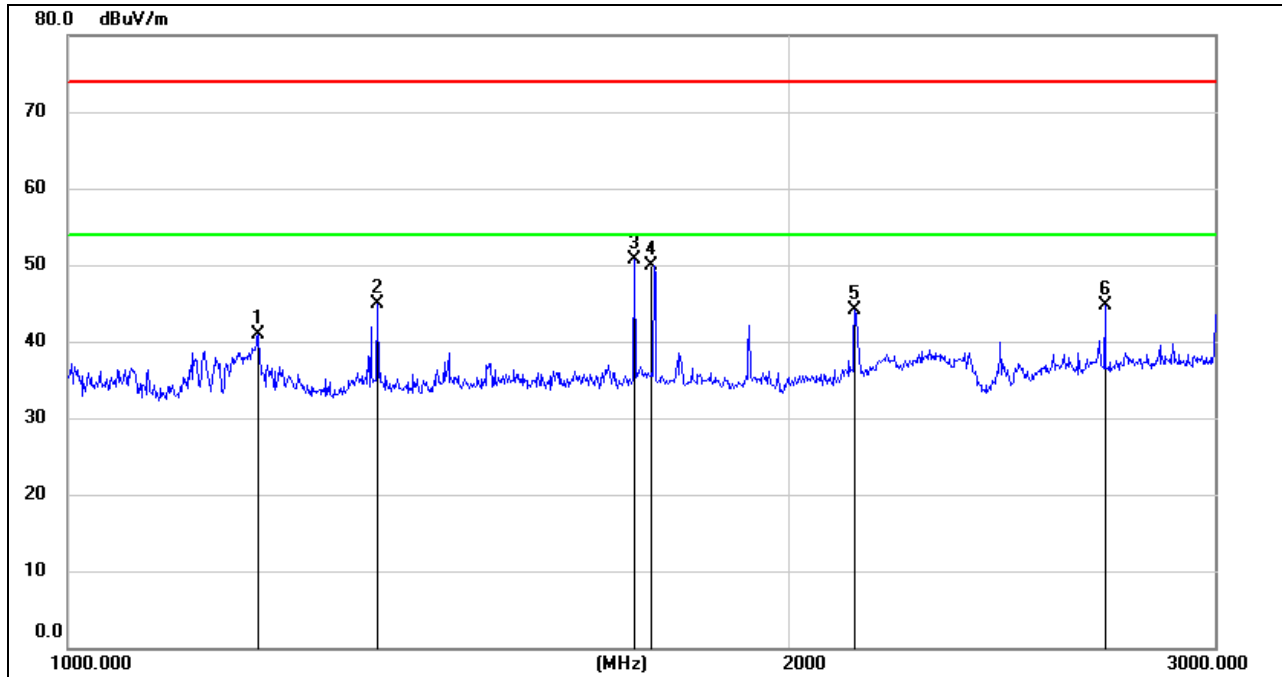

No.	Frequency (MHz)	Reading (dBuV/m)	Correct dB/m	Result (dBuV/m)	Limit (dBuV/m)	Margin (dB)	Remark
1	1200.058	54.12	-13.17	40.95	74.00	-33.05	peak
2	1345.311	57.21	-12.40	44.81	74.00	-29.19	peak
3	1720.671	62.16	-11.42	50.74	74.00	-23.26	peak
4	1753.109	61.22	-11.27	49.95	74.00	-24.05	peak
5	2124.737	53.53	-9.35	44.18	74.00	-29.82	peak
6	2699.713	52.33	-7.60	44.73	74.00	-29.27	peak

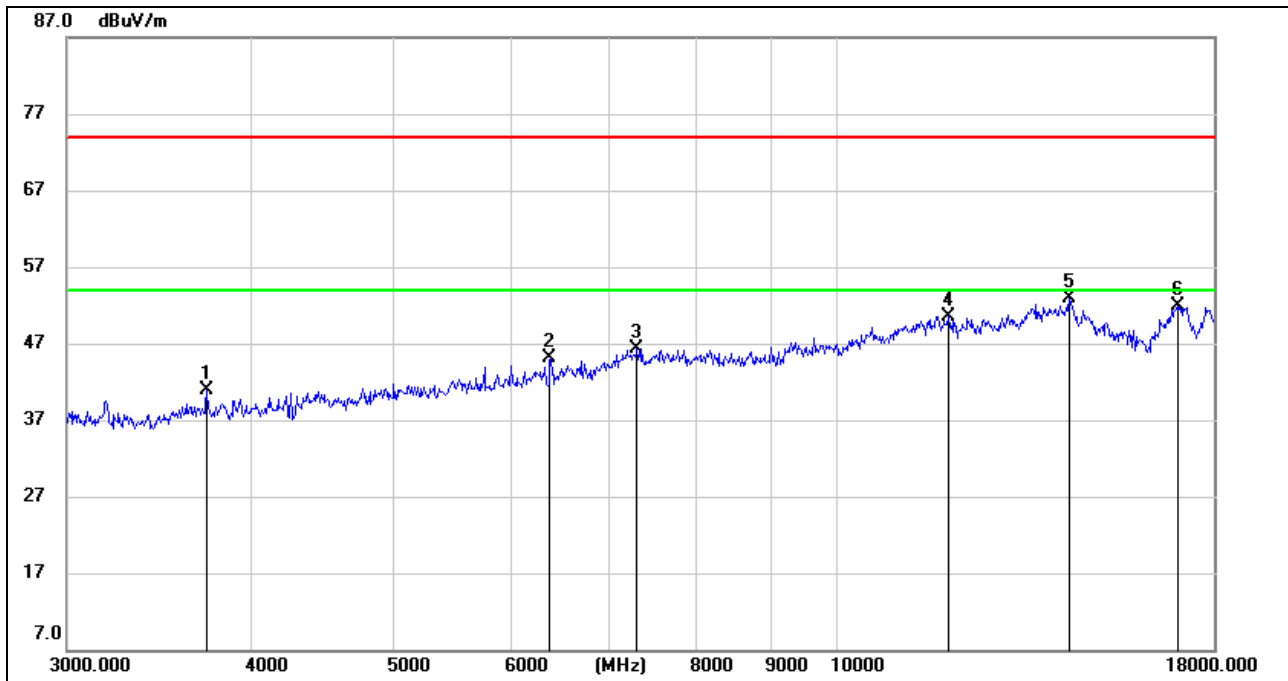

No.	Frequency (MHz)	Reading (dBuV/m)	Correct dB/m	Result (dBuV/m)	Limit (dBuV/m)	Margin (dB)	Remark
1	3739.675	44.46	-3.52	40.94	74.00	-33.06	peak
2	6390.003	40.43	4.73	45.16	74.00	-28.84	peak
3	7309.075	38.52	7.77	46.29	74.00	-27.71	peak
4	11920.589	33.94	16.64	50.58	74.00	-23.42	peak
5	14362.348	32.48	20.33	52.81	74.00	-21.19	peak
6	16996.976	29.65	22.25	51.90	74.00	-22.10	peak

- Note: 1. Measurement = Reading Level + Correct Factor.  
 2. If Peak Result complies with AV limit, AV Result is deemed to comply with AV limit.  
 3. Peak: Peak detector.  
 4. AVG: VBW=1/Ton where: ton is transmit duration.  
 5. For transmit duration, please refer to clause 6.1.

**HARMONICS AND SPURIOUS EMISSIONS (HIGH CHANNEL, HORIZONTAL)**

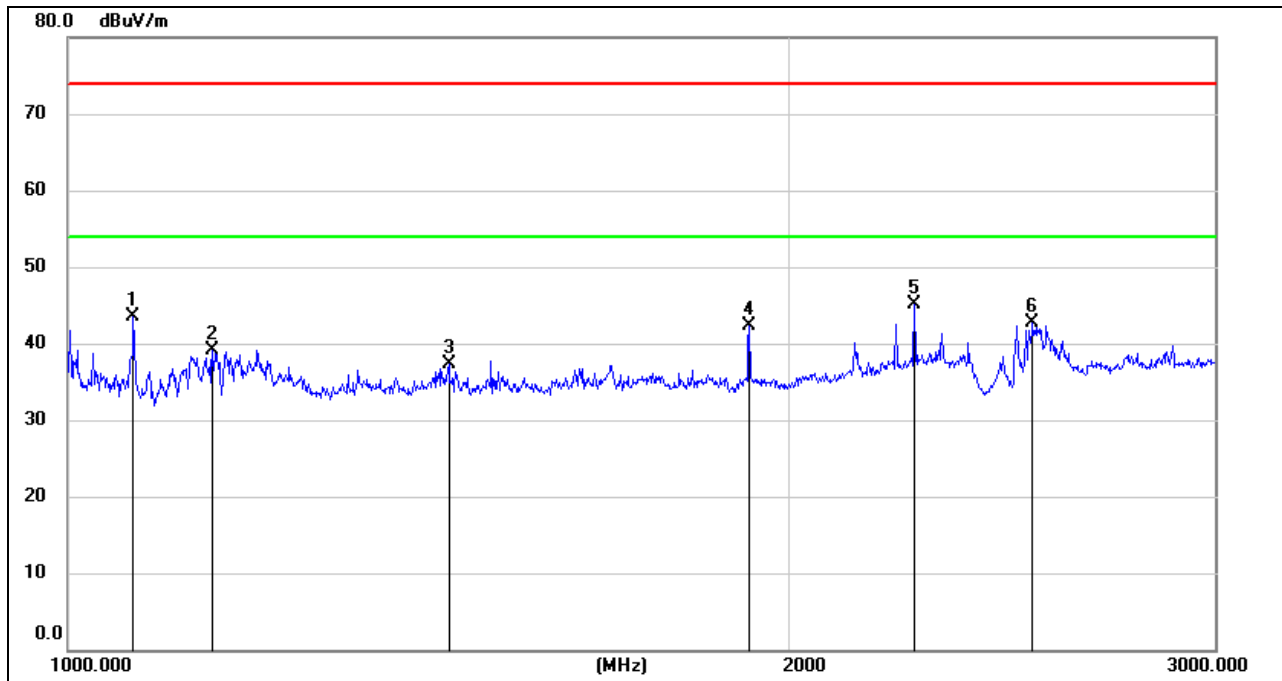

No.	Frequency (MHz)	Reading (dBuV/m)	Correct dB/m	Result (dBuV/m)	Limit (dBuV/m)	Margin (dB)	Remark
1	1064.623	57.13	-13.62	43.51	74.00	-30.49	peak
2	1148.464	52.40	-13.36	39.04	74.00	-34.96	peak
3	1440.139	49.48	-12.22	37.26	74.00	-36.74	peak
4	1920.481	53.08	-10.72	42.36	74.00	-31.64	peak
5	2249.653	52.80	-7.60	45.20	74.00	-28.80	peak
6	2519.179	51.17	-8.38	42.79	74.00	-31.21	peak

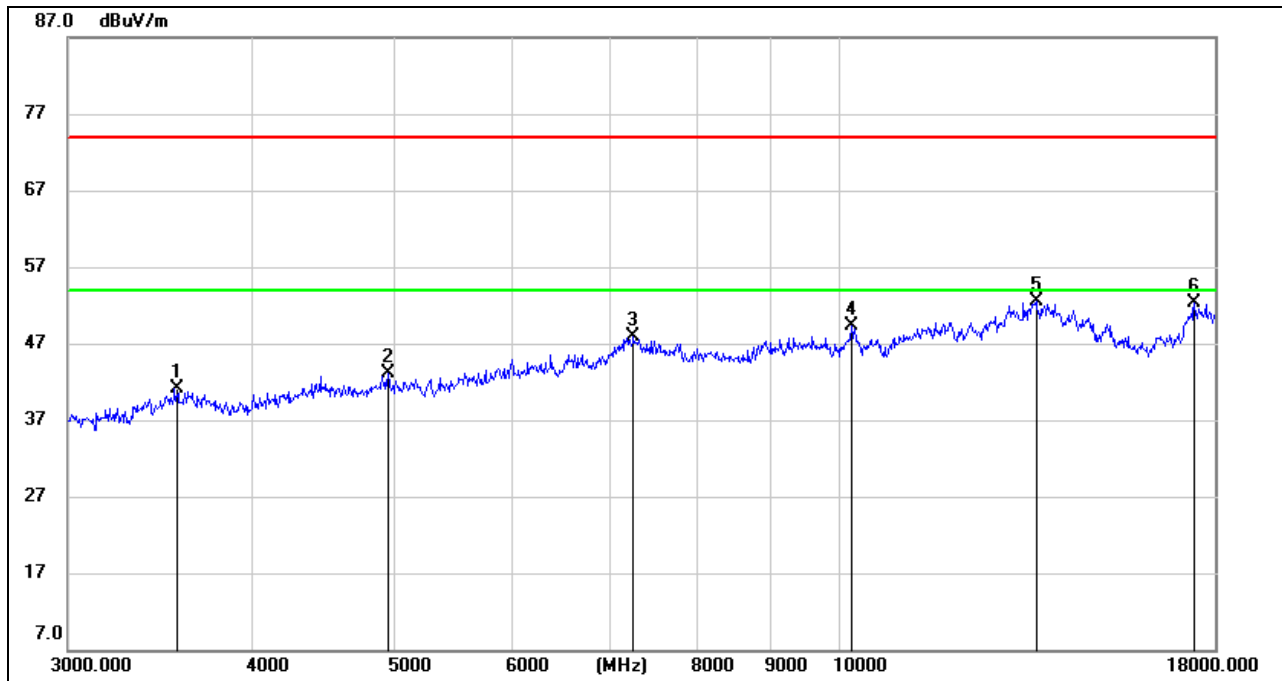

No.	Frequency (MHz)	Reading (dBuV/m)	Correct dB/m	Result (dBuV/m)	Limit (dBuV/m)	Margin (dB)	Remark
1	3550.320	45.26	-4.21	41.05	74.00	-32.95	peak
2	4945.674	42.57	0.60	43.17	74.00	-30.83	peak
3	7256.878	40.00	7.86	47.86	74.00	-26.14	peak
4	10199.962	36.61	12.61	49.22	74.00	-24.78	peak
5	13610.714	31.91	20.53	52.44	74.00	-21.56	peak
6	17428.732	29.19	23.15	52.34	74.00	-21.66	peak

- Note: 1. Measurement = Reading Level + Correct Factor.  
 2. If Peak Result complies with AV limit, AV Result is deemed to comply with AV limit.  
 3. Peak: Peak detector.  
 4. AVG: VBW=1/Ton where: ton is transmit duration.  
 5. For transmit duration, please refer to clause 6.1.

**HARMONICS AND SPURIOUS EMISSIONS (HIGH CHANNEL, VERTICAL)**

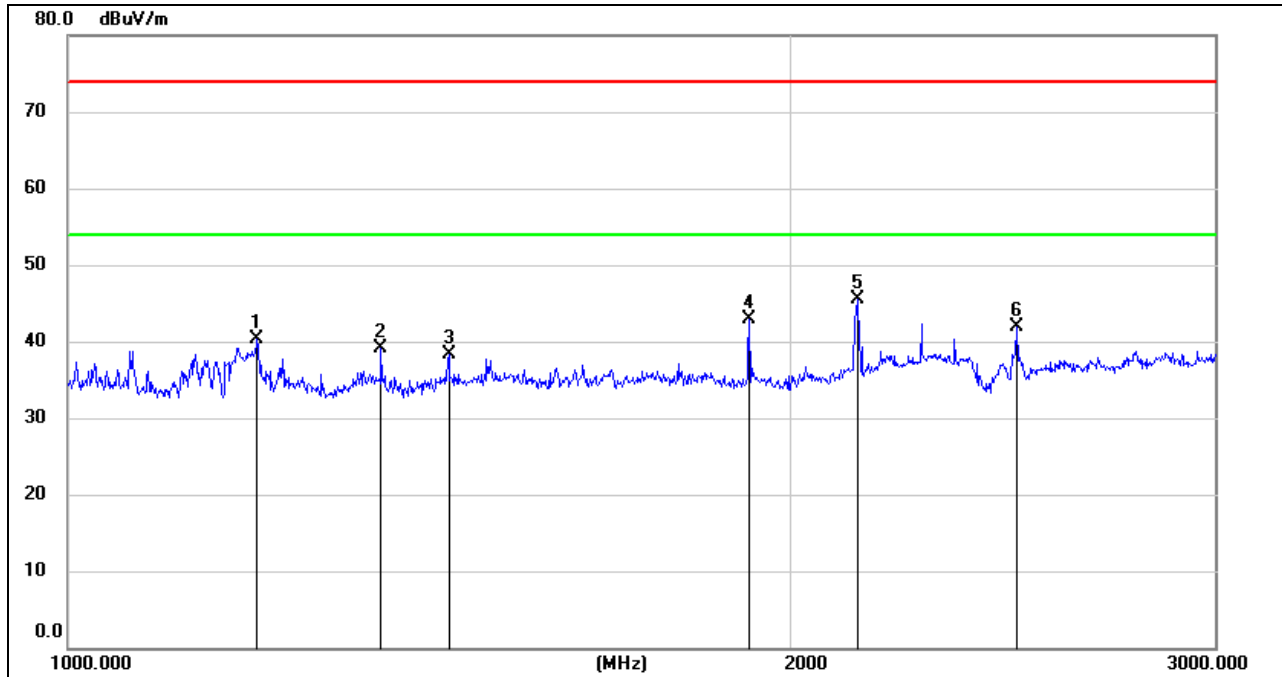

No.	Frequency (MHz)	Reading (dBuV/m)	Correct dB/m	Result (dBuV/m)	Limit (dBuV/m)	Margin (dB)	Remark
1	1198.740	53.52	-13.18	40.34	74.00	-33.66	peak
2	1351.236	51.50	-12.39	39.11	74.00	-34.89	peak
3	1440.139	50.64	-12.30	38.34	74.00	-35.66	peak
4	1920.481	53.78	-10.82	42.96	74.00	-31.04	peak
5	2129.411	54.75	-9.30	45.45	74.00	-28.55	peak
6	2480.729	50.14	-8.28	41.86	74.00	-32.14	peak

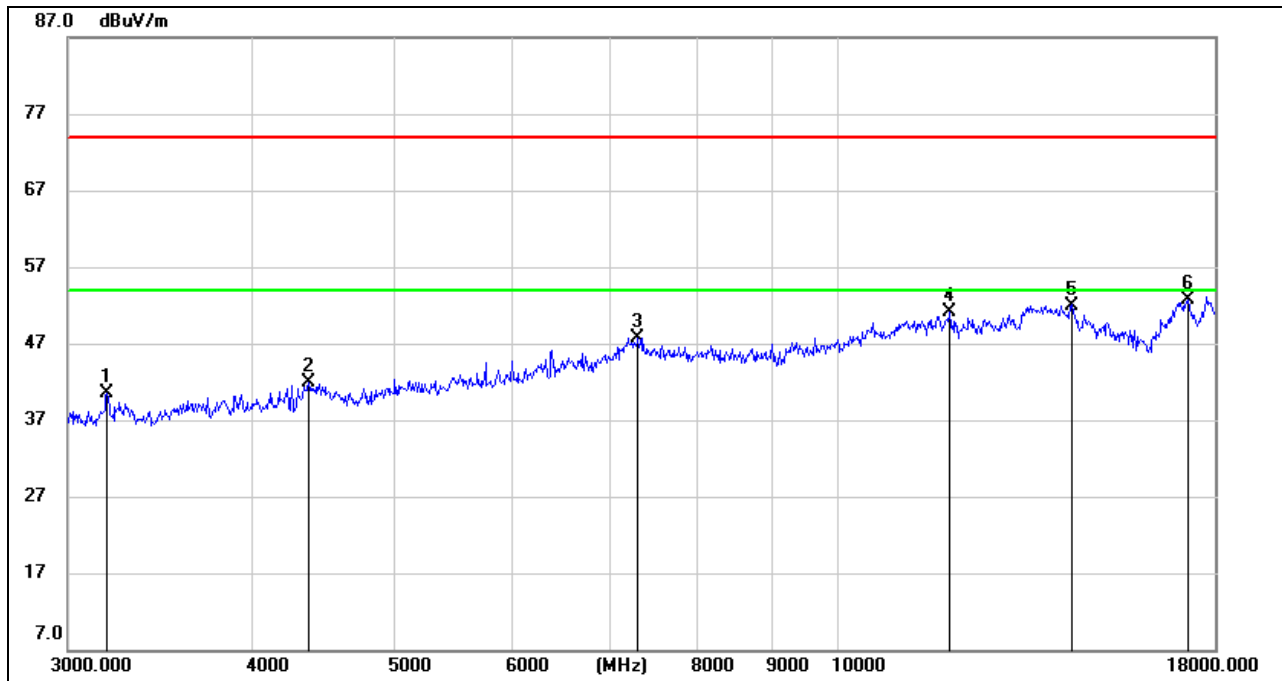

No.	Frequency (MHz)	Reading (dBuV/m)	Correct dB/m	Result (dBuV/m)	Limit (dBuV/m)	Margin (dB)	Remark
1	3188.441	45.27	-4.76	40.51	74.00	-33.49	peak
2	4370.519	42.90	-0.98	41.92	74.00	-32.08	peak
3	7309.075	40.02	7.77	47.79	74.00	-26.21	peak
4	11920.589	34.44	16.64	51.08	74.00	-22.92	peak
5	14388.105	31.62	20.38	52.00	74.00	-22.00	peak
6	17273.288	29.51	23.15	52.66	74.00	-21.34	peak

- Note: 1. Measurement = Reading Level + Correct Factor.  
 2. If Peak Result complies with AV limit, AV Result is deemed to comply with AV limit.  
 3. Peak: Peak detector.  
 4. AVG: VBW=1/Ton where: ton is transmit duration.  
 5. For transmit duration, please refer to clause 6.1.

## 7.4. SPURIOUS EMISSIONS 18G ~ 26GHz

### 7.4.1. GFSK MODE

#### ANTENNA1 (WORST-CASE CONFIGURATION)

#### SPURIOUS EMISSIONS (MID CHANNEL, WORST-CASE CONFIGURATION, HORIZONTAL)

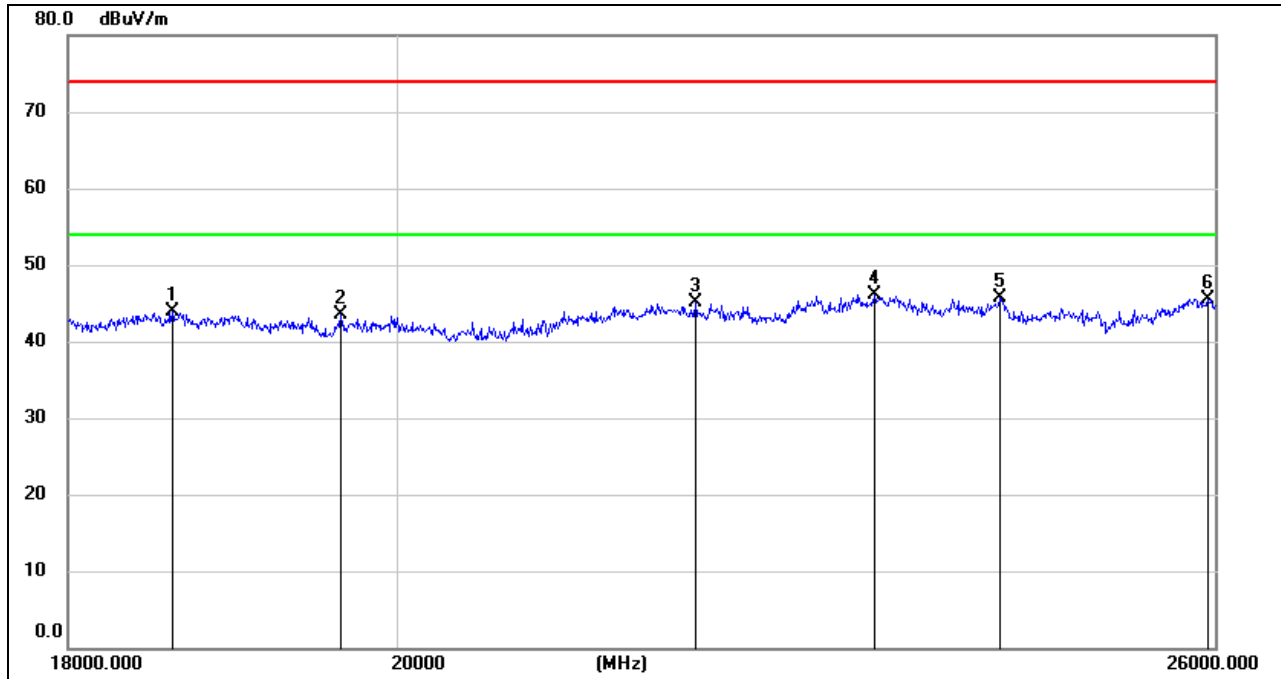

No.	Frequency (MHz)	Reading (dBuV/m)	Correct dB/m	Result (dBuV/m)	Limit (dBuV/m)	Margin (dB)	Remark
1	18612.524	49.24	-5.34	43.90	74.00	-30.10	peak
2	19646.324	48.86	-5.38	43.48	74.00	-30.52	peak
3	22010.447	49.66	-4.47	45.19	74.00	-28.81	peak
4	23309.996	49.47	-3.31	46.16	74.00	-27.84	peak
5	24263.284	48.61	-2.81	45.80	74.00	-28.20	peak
6	25942.698	46.50	-0.96	45.54	74.00	-28.46	peak

Note: 1. Peak Result= Reading Level + Correct Factor.

2. If Peak Result complies with AV limit, AV Result is deemed to comply with AV limit.

3. All the modes had been tested, but only the worst data were recorded in the report.

**SPURIOUS EMISSIONS (MID CHANNEL, WORST-CASE CONFIGURATION, VERTICAL)**

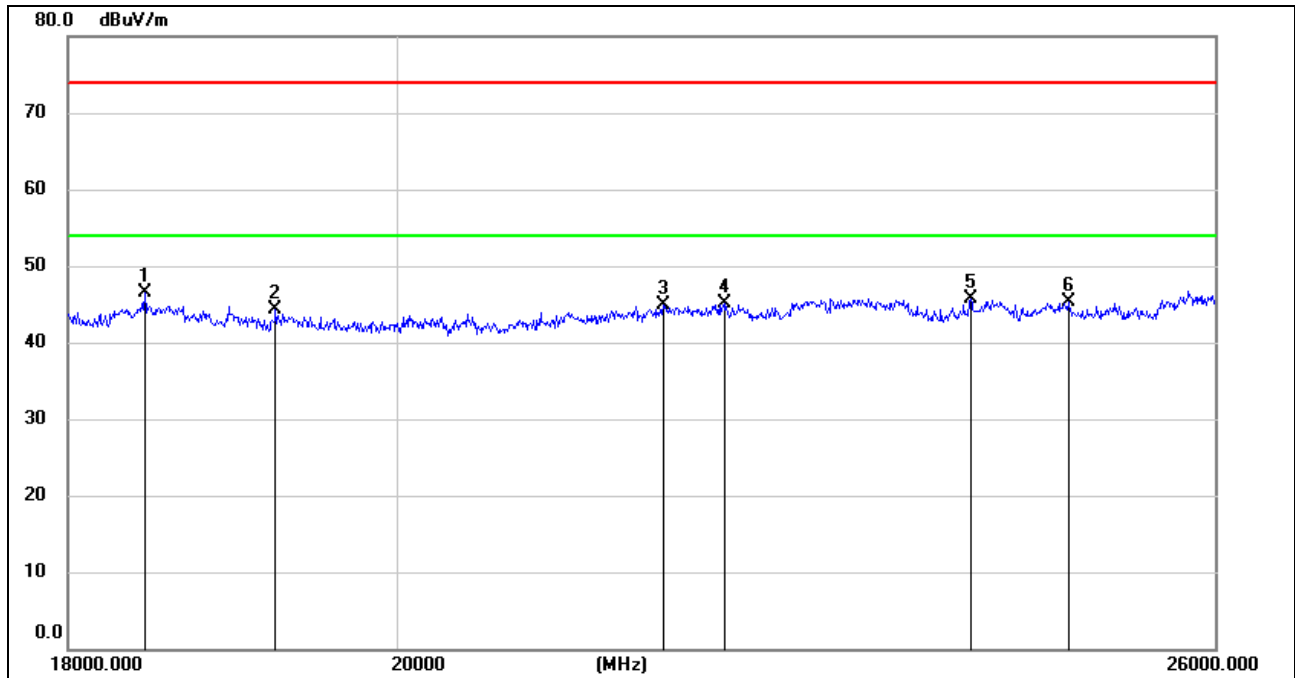

No.	Frequency (MHz)	Reading (dBuV/m)	Correct dB/m	Result (dBuV/m)	Limit (dBuV/m)	Margin (dB)	Remark
1	18448.984	51.77	-5.32	46.45	74.00	-27.55	peak
2	19238.817	49.78	-5.57	44.21	74.00	-29.79	peak
3	21784.984	49.17	-4.34	44.83	74.00	-29.17	peak
4	22221.895	49.34	-4.26	45.08	74.00	-28.92	peak
5	24041.251	48.46	-2.76	45.70	74.00	-28.30	peak
6	24804.566	47.55	-2.27	45.28	74.00	-28.72	peak

- Note: 1. Peak Result = Reading Level + Correct Factor.  
 2. If Peak Result complies with AV limit, AV Result is deemed to comply with AV limit.  
 3. All the modes had been tested, but only the worst data were recorded in the report.

Note: All the modulation and channels had been tested, but only the worst data recorded in the report.

## 7.5. SPURIOUS EMISSIONS 30M ~ 1 GHz

### 7.5.1. GFSK MODE

#### ANTENNA1 (WORST-CASE CONFIGURATION)

#### SPURIOUS EMISSIONS (MID CHANNEL, WORST-CASE CONFIGURATION, HORIZONTAL)

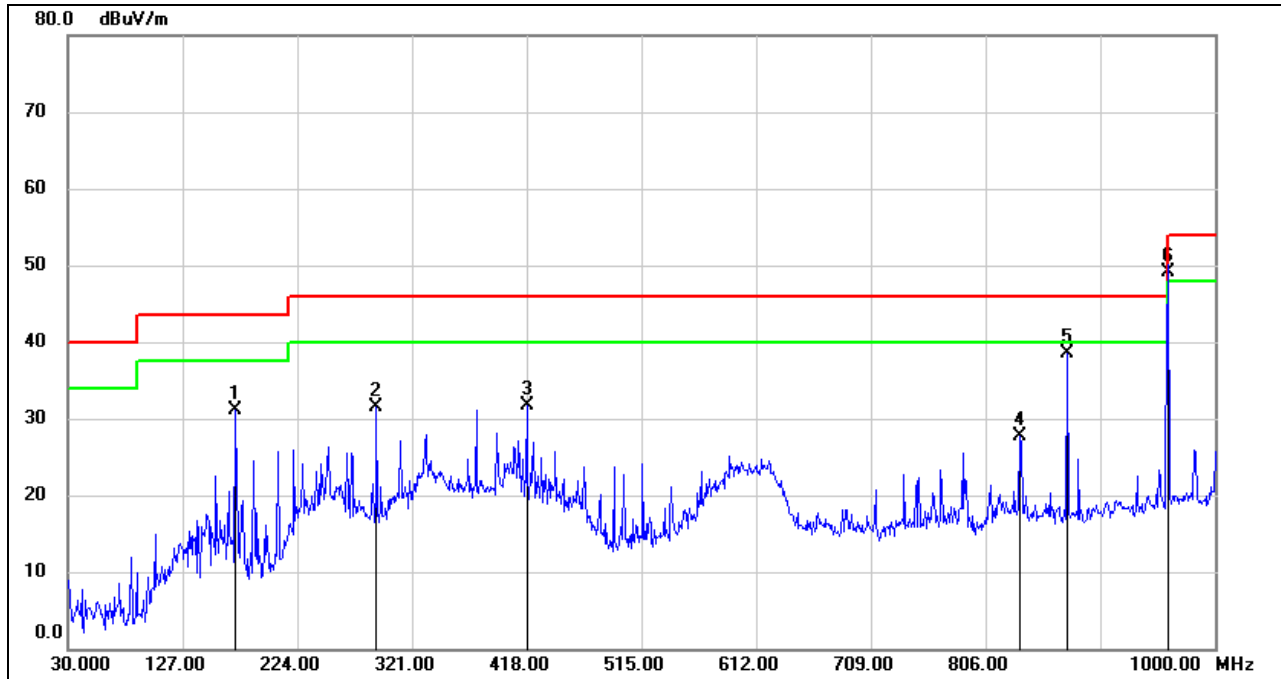

No.	Frequency (MHz)	Reading (dBuV/m)	Correct dB/m	Result (dBuV/m)	Limit (dBuV/m)	Margin (dB)	Remark
1	171.6200	59.46	-28.33	31.13	43.50	-12.37	QP
2	290.9300	59.51	-28.01	31.50	46.00	-14.50	QP
3	418.0000	56.39	-24.59	31.80	46.00	-14.20	QP
4	835.1000	44.61	-16.90	27.71	46.00	-18.29	QP
5	874.8700	55.67	-17.24	38.43	46.00	-7.57	QP
6	960.2300	64.55	-15.41	49.14	54.00	-4.86	QP

- Note: 1. Result Level = Read Level + Antenna Factor + Cable loss.  
 2. If Peak Result complies with QP limit, QP Result is deemed to comply with QP limit.  
 3. Test setup: RBW: 120 kHz, VBW: 300 kHz, Sweep time: auto.

**SPURIOUS EMISSIONS (MID CHANNEL, WORST-CASE CONFIGURATION, VERTICAL)**

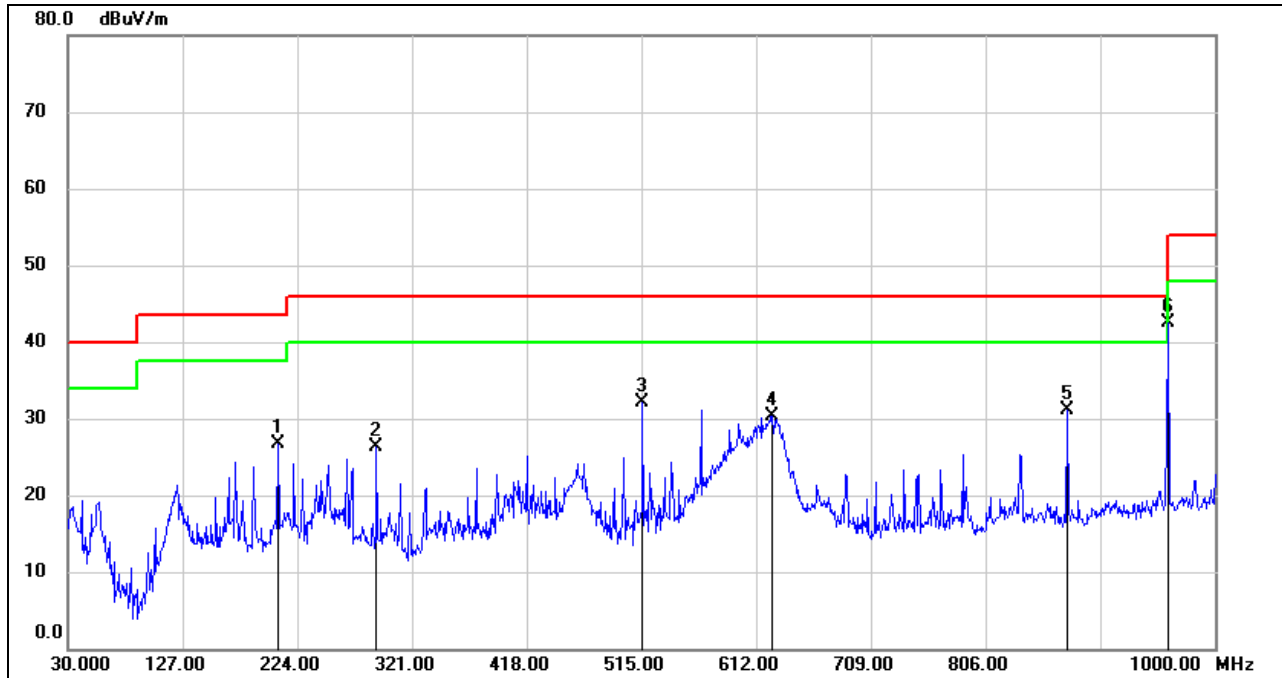

No.	Frequency (MHz)	Reading (dBuV/m)	Correct dB/m	Result (dBuV/m)	Limit (dBuV/m)	Margin (dB)	Remark
1	207.5100	54.57	-27.91	26.66	43.50	-16.84	QP
2	290.9300	54.40	-28.01	26.39	46.00	-19.61	QP
3	515.9699	53.70	-21.62	32.08	46.00	-13.92	QP
4	625.5800	50.73	-20.39	30.34	46.00	-15.66	QP
5	874.8700	48.32	-17.24	31.08	46.00	-14.92	QP
6	960.2300	58.00	-15.41	42.59	54.00	-11.41	QP

- Note: 1. Result Level = Read Level + Antenna Factor + Cable loss.  
 2. If Peak Result complies with QP limit, QP Result is deemed to comply with QP limit.  
 3. Test setup: RBW: 120 kHz, VBW: 300 kHz, Sweep time: auto

Note: All the modulation and channels had been tested, but only the worst data recorded in the report.

## 7.6. SPURIOUS EMISSIONS BELOW 30M

### 7.6.1. GFSK MODE

#### SPURIOUS EMISSIONS (MID CHANNEL, WORST-CASE CONFIGURATION, HORIZONTAL)

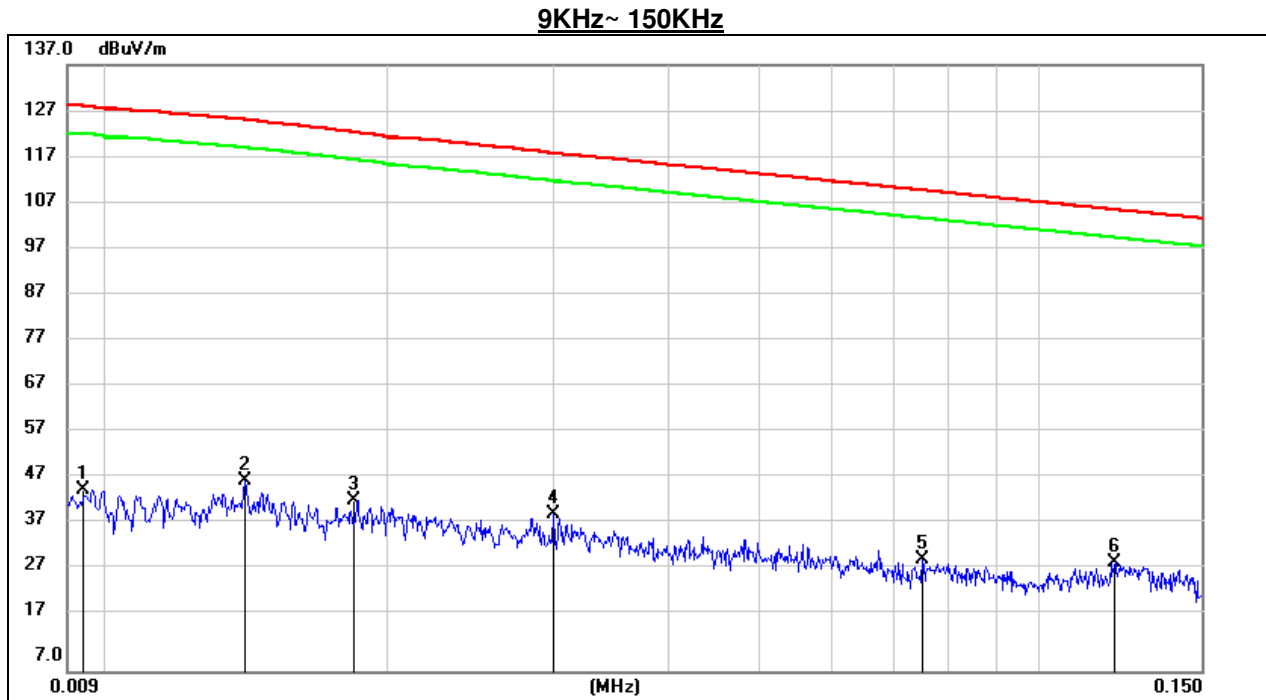

No.	Frequency (MHz)	Reading (dBuV/m)	Correct dB/m	Result (dBuV/m)	Limit (dBuV/m)	Margin (dB)	Remark
1	0.0094	25.44	20.26	45.70	128.06	-82.36	QP
2	0.0140	27.42	20.25	47.67	125.19	-77.52	QP
3	0.0183	23.34	20.29	43.63	122.60	-78.97	QP
4	0.0300	20.37	20.31	40.68	118.06	-77.38	QP
5	0.0751	10.43	20.31	30.74	110.11	-79.37	QP
6	0.1208	9.91	20.30	30.21	105.96	-75.75	QP

Note: 1. Measurement = Reading Level + Correct Factor.  
 2. All the modes had been tested, but only the worst data were recorded in the report.  
 3. If Peak Result complies with AV and QP limit, AV and QP Result are deemed to comply with AV limit.

**150KHz ~ 30M**

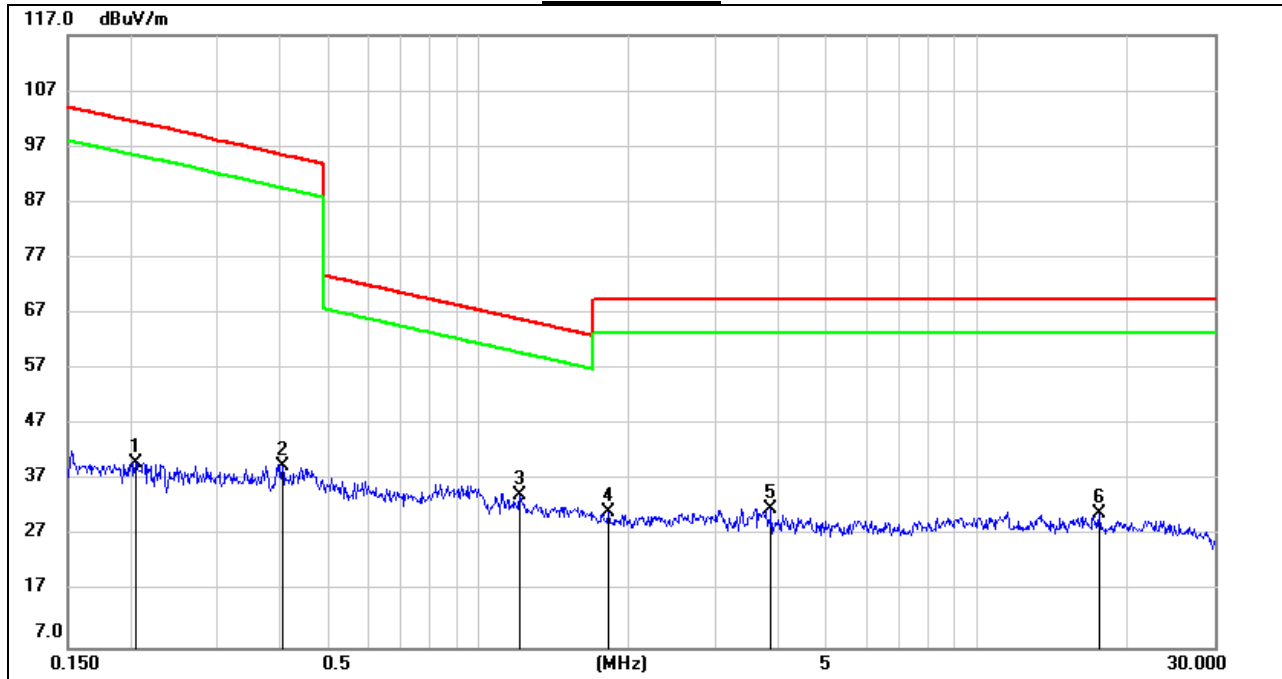

No.	Frequency (MHz)	Reading (dBuV/m)	Correct dB/m	Result (dBuV/m)	Limit (dBuV/m)	Margin (dB)	Remark
1	0.2048	19.91	20.36	40.27	101.41	-61.14	QP
2	0.4040	19.44	20.27	39.71	95.48	-55.77	QP
3	1.2096	13.91	20.44	34.35	65.95	-31.60	QP
4	1.8185	10.54	20.67	31.21	69.54	-38.33	QP
5	3.8603	10.95	21.04	31.99	69.54	-37.55	QP
6	17.5670	9.95	20.99	30.94	69.54	-38.60	QP

Note: 1. Measurement = Reading Level + Correct Factor.  
 2. All the modes had been tested, but only the worst data were recorded in the report.  
 3. If Peak Result complies with AV and QP limit, AV and QP Result are deemed to comply with AV limit.

**SPURIOUS EMISSIONS (MID CHANNEL, WORST-CASE CONFIGURATION, VERTICAL)**

**9KHz~ 150KHz**

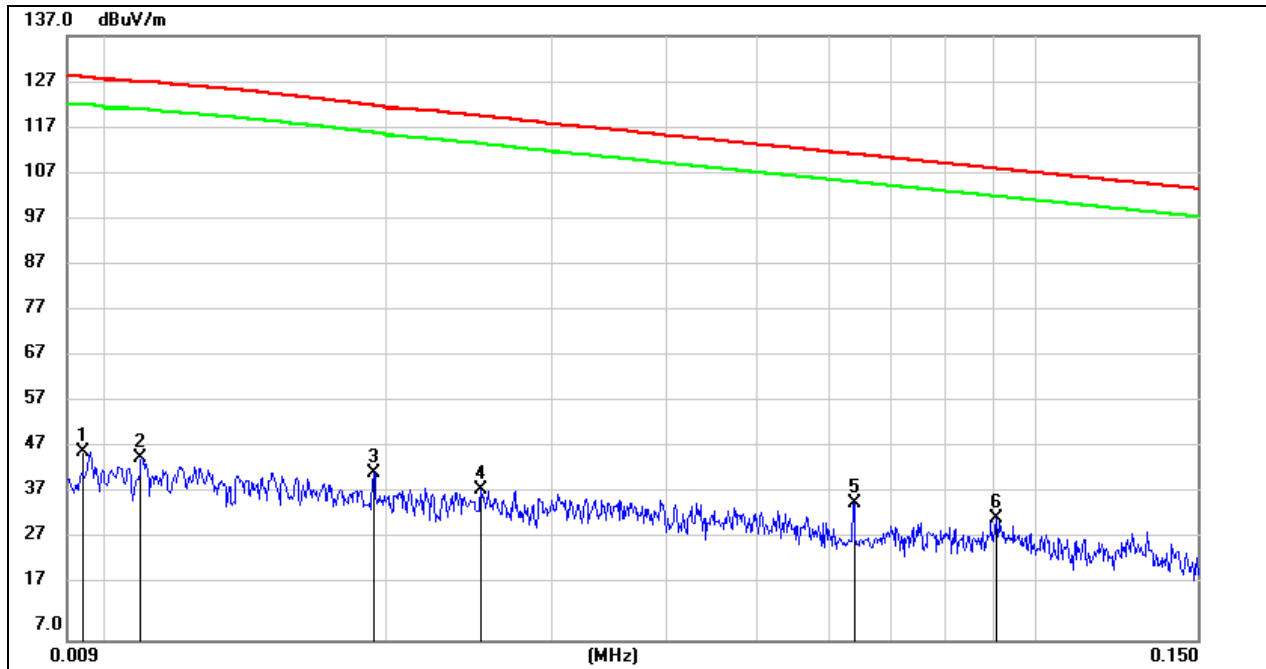

No.	Frequency (MHz)	Reading (dBuV/m)	Correct dB/m	Result (dBuV/m)	Limit (dBuV/m)	Margin (dB)	Remark
1	0.0094	27.12	20.26	47.38	128.06	-80.68	QP
2	0.0108	25.96	20.22	46.18	127.12	-80.94	QP
3	0.0193	22.68	20.30	42.98	122.00	-79.02	QP
4	0.0252	19.01	20.31	39.32	119.75	-80.43	QP
5	0.0637	16.10	20.31	36.41	111.54	-75.13	QP
6	0.0908	13.06	20.26	33.32	108.45	-75.13	QP

- Note: 1. Measurement = Reading Level + Correct Factor.  
 2. All the modes had been tested, but only the worst data were recorded in the report.  
 3. If Peak Result complies with AV and QP limit, AV and QP Result are deemed to comply with AV limit.

**150KHz ~ 30M**

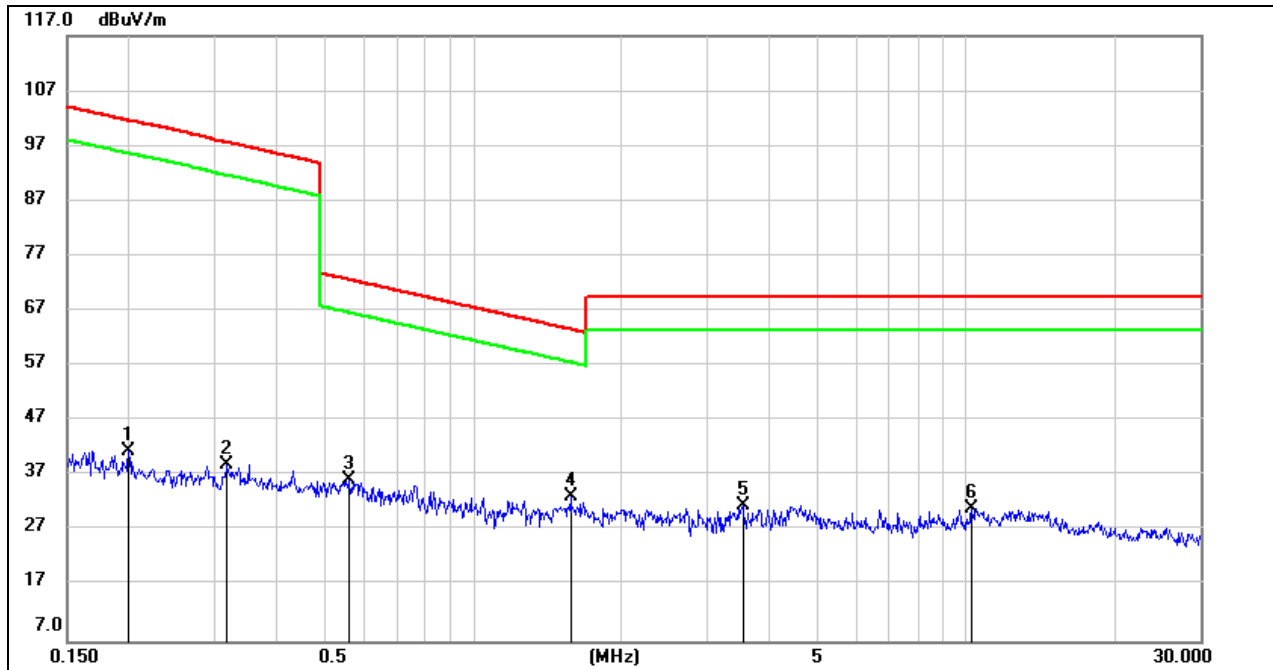

No.	Frequency (MHz)	Reading (dBuV/m)	Correct dB/m	Result (dBuV/m)	Limit (dBuV/m)	Margin (dB)	Remark
1	0.1995	21.05	20.37	41.42	101.60	-60.18	QP
2	0.3165	18.77	20.30	39.07	97.65	-58.58	QP
3	0.5581	16.00	20.26	36.26	72.71	-36.45	QP
4	1.5766	12.69	20.58	33.27	63.65	-30.38	QP
5	3.5278	10.67	20.98	31.65	69.54	-37.89	QP
6	10.2873	9.91	21.05	30.96	69.54	-38.58	QP

Note: 1. Measurement = Reading Level + Correct Factor.  
 2. All the modes had been tested, but only the worst data were recorded in the report.  
 3. If Peak Result complies with AV and QP limit, AV and QP Result are deemed to comply with AV limit.

Note: All the modulation and channels had been tested, but only the worst data recorded in the report.

## 8. AC POWER LINE CONDUCTED EMISSIONS

### LIMITS

Please refer to FCC §15.207 (a) and RSS-Gen Clause 8.8.

FREQUENCY (MHz)	Class A (dBuV)		Class B (dBuV)	
	Quasi-peak	Average	Quasi-peak	Average
0.15 -0.5	79.00	66.00	66 - 56 *	56 - 46 *
0.50 -5.0	73.00	60.00	56.00	46.00
5.0 -30.0	73.00	60.00	60.00	50.00

### TEST SETUP AND PROCEDURE

The EUT is put on a table of non-conducting material that is 12mm high. The vertical conducting wall of shielding is located 40cm to the rear of the EUT. The power line of the EUT is connected to the AC mains through a Artificial Mains Network (A.M.N.). A EMI Measurement Receiver (R&S Test Receiver ESR3) is used to test the emissions from both sides of AC line. According to the requirements in Section 6.2 of ANSI C63.10-2013. Conducted emissions from the EUT measured in the frequency range between 0.15 MHz and 30MHz using CISPR Quasi-Peak and average detector mode. The bandwidth of EMI test receiver is set at 9kHz. The arrangement of the equipment is installed to meet the standards and operating in a manner, which tends to maximize its emission characteristics in a normal application.

### 8.1.1. GFSK MODE

#### TEST RESULTS (MID CHANNEL, WORST-CASE CONFIGURATION)

#### LINE N RESULTS

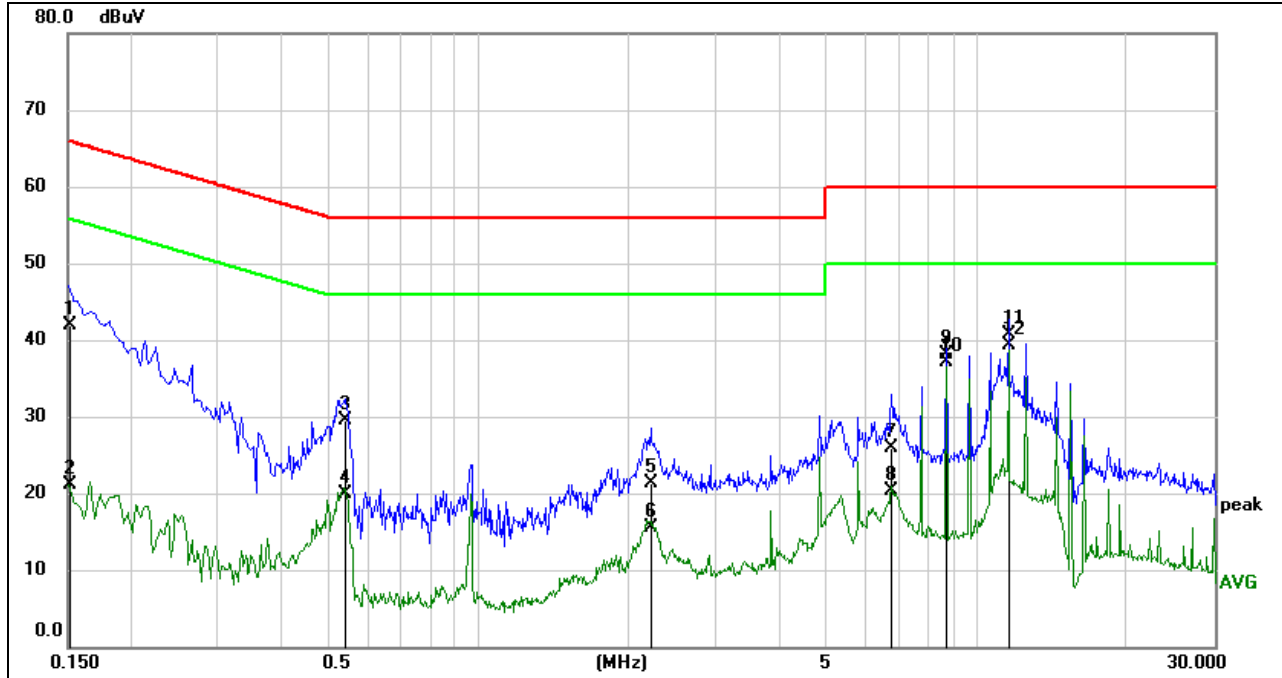

No.	Frequency (MHz)	Reading (dBuV)	Correct dB	Result (dBuV)	Limit (dBuV)	Margin (dB)	Remark
1	0.1516	32.25	9.65	41.90	65.91	-24.01	QP
2	0.1516	11.45	9.65	21.10	55.91	-34.81	AVG
3	0.5416	19.94	9.65	29.59	56.00	-26.41	QP
4	0.5416	10.19	9.65	19.84	46.00	-26.16	AVG
5	2.2234	11.70	9.67	21.37	56.00	-34.63	QP
6	2.2234	5.87	9.67	15.54	46.00	-30.46	AVG
7	6.7669	16.07	9.74	25.81	60.00	-34.19	QP
8	6.7669	10.57	9.74	20.31	50.00	-29.69	AVG
9	8.7012	28.38	9.77	38.15	60.00	-21.85	QP
10	8.7012	27.33	9.77	37.10	50.00	-12.90	AVG
11	11.6006	30.83	9.80	40.63	60.00	-19.37	QP
12	11.6006	29.54	9.80	39.34	50.00	-10.66	AVG

- Note: 1. Result = Reading +Correct Factor.  
 2. If QP Result complies with AV limit, AV Result is deemed to comply with AV limit.  
 3. Test setup: RBW: 200 Hz (9 kHz—150 kHz), 9 kHz (150 kHz—30 MHz).  
 4. Step size: 80Hz (0.009MHz-0.15MHz), 4 kHz (0.15MHz-30MHz), Scan time: auto.

**LINE L RESULTS**

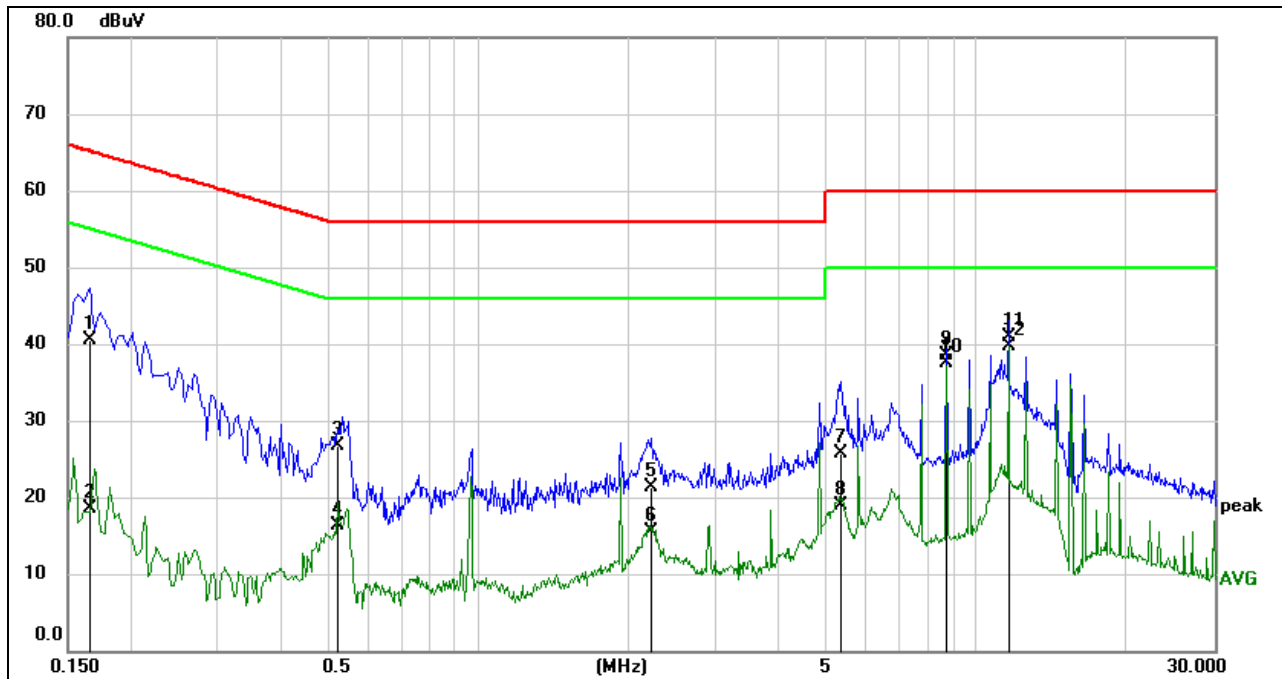

No.	Frequency (MHz)	Reading (dBuV)	Correct (dB)	Result (dBuV)	Limit (dBuV)	Margin (dB)	Remark
1	0.1663	30.76	9.66	40.42	65.14	-24.72	QP
2	0.1663	8.76	9.66	18.42	55.14	-36.72	AVG
3	0.5248	17.11	9.65	26.76	56.00	-29.24	QP
4	0.5248	6.69	9.65	16.34	46.00	-29.66	AVG
5	2.2076	11.71	9.68	21.39	56.00	-34.61	QP
6	2.2076	5.74	9.68	15.42	46.00	-30.58	AVG
7	5.3516	15.98	9.72	25.70	60.00	-34.30	QP
8	5.3516	9.18	9.72	18.90	50.00	-31.10	AVG
9	8.7010	28.67	9.77	38.44	60.00	-21.56	QP
10	8.7010	27.78	9.77	37.55	50.00	-12.45	AVG
11	11.6016	31.13	9.80	40.93	60.00	-19.07	QP
12	11.6016	29.86	9.80	39.66	50.00	-10.34	AVG

- Note: 1. Result = Reading +Correct Factor.  
 2. If QP Result complies with AV limit, AV Result is deemed to comply with AV limit.  
 3. Test setup: RBW: 200 Hz (9 kHz—150 kHz), 9 kHz (150 kHz—30 MHz).  
 4. Step size: 80Hz (0.009MHz-0.15MHz), 4 kHz (0.15MHz-30MHz), Scan time: auto.

Note: All the modulation and channels had been tested, but only the worst data recorded in the report.

## **9. ANTENNA REQUIREMENTS**

### **APPLICABLE REQUIREMENTS**

Please refer to FCC §15.203

An intentional radiator shall be designed to ensure that no antenna other than that furnished by the responsible party shall be used with the device. The use of a permanently attached antenna or of an antenna that uses a unique coupling to the intentional radiator shall be considered sufficient to comply with the provisions of this section. The manufacturer may design the unit so that a broken antenna can be replaced by the user, but the use of a standard antenna jack or electrical connector is prohibited.

Please refer to FCC §15.247(b)(4)

The conducted output power limit specified in paragraph (b) of this section is based on the use of antennas with directional gains that do not exceed 6 dBi. Except as shown in paragraph (c) of this section, if transmitting antennas of directional gain greater than 6 dBi are used, the conducted output power from the intentional radiator shall be reduced below the stated values in paragraphs (b)(1), (b)(2), and (b)(3) of this section, as appropriate, by the amount in dB that the directional gain of the antenna exceeds 6 dBi.

### **ANTENNA CONNECTOR**

EUT has an external antenna with antenna connector, it will be installed in a specific environment and users cannot change the antenna.

### **ANTENNA GAIN**

The antenna gain of EUT is less than 6 dBi.

**END OF REPORT**