

Ericsson AB

RF TEST REPORT

Report Type:
FCC Part 24 RF report

PRODUCT NAME:
Radio 4415 B2 B25

REPORT NUMBER:
230200506SHA-001

ISSUE DATE:
February 14, 2023

DOCUMENT CONTROL NUMBER:
TTRFFCC Part 24_V1 © 2018 Intertek



TEST REPORT

Applicant: Ericsson AB
Isafjordsgatan 10 SE-164 80 Stockholm 16480 Sweden

Manufacturer: Ericsson AB
Isafjordsgatan 10 SE-164 80 Stockholm 16480 Sweden

FCC ID: TA8AKRC161636

IC: 287AB-AS161636

SUMMARY:

The equipment is tested according to the following standard(s) or Specification:

FCC CFR 47 Part 24: PERSONAL COMMUNICATIONS SERVICES

ISED RSS-133 Issue 6: 2 GHz Personal Communications Services

PREPARED BY:

REVIEWED BY:

Project Engineer
Victor Yang

Reviewer
Jackson Huang

This report is for the exclusive use of Intertek's Client and is provided pursuant to the agreement between Intertek and its Client. Intertek's responsibility and liability are limited to the terms and conditions of the agreement. Intertek assumes no liability to any party, other than to the Client in accordance with the agreement, for any loss, expense or damage occasioned by the use of this report. Only the Client is authorized to permit copying or distribution of this report and then only in its entirety. Any use of the Intertek name or one of its marks for the sale or advertisement of the tested material, product or service must first be approved in writing by Intertek. The observations and test results in this report are relevant only to the sample tested. This report by itself does not imply that the material, product, or service is or has ever been under an Intertek certification program.

TEST REPORT

Content

REVISION HISTORY	4
MEASUREMENT RESULT SUMMARY	5
1 GENERAL INFORMATION	6
1.1 DESCRIPTION OF EQUIPMENT UNDER TEST (EUT)	6
1.2 TECHNICAL SPECIFICATION	7
1.3 DESCRIPTION OF TEST FACILITY	8
2 TEST SPECIFICATIONS	9
2.1 RELATED DOCUMENTS	9
2.2 PRODUCT INFORMATION.....	9
2.3 CONFIGURATION DESCRIPTION.....	10
2.4 TEST SETUP.....	11
2.5 TEST ENVIRONMENT CONDITION:.....	12
2.6 INSTRUMENT LIST	13
2.7 MEASUREMENT UNCERTAINTY	14
3 MAXIMUM OUTPUT POWER AND PEAK TO AVERAGE POWER RATIO AND EIRP	15
3.1 LIMIT	15
3.2 MEASUREMENT PROCEDURE	15
3.3 MEASUREMENT RESULT	16
4 OCCUPIED BANDWIDTH	18
4.1 MEASUREMENT PROCEDURE	18
4.2 MEASUREMENT RESULT	19
5 UNWANTED EMISSIONS AT BAND EDGE	24
5.1 LIMIT	24
5.2 MEASUREMENT PROCEDURE	24
5.3 MEASUREMENT RESULT	25
6 CONDUCTED UNWANTED EMISSION	31
6.1 LIMIT	31
6.2 MEASUREMENT PROCEDURE	31
6.3 MEASUREMENT RESULT	32
7 FREQUENCY STABILITY	59
7.1 LIMIT	59
7.2 MEASUREMENT PROCEDURE	59
7.3 MEASUREMENT RESULT	60

Revision History

Report No.	Version	Description	Issued Date
230200506SHA-001	Rev. 01	Initial issue of report	February 14, 2023

Measurement result summary

TEST ITEM	FCC REFERANCE	IC REFERANCE	RESULT
Max Output Power and Peak to Average Power Ratio and EIRP	24.232(a) 2.1046	RSS-133 6.4	Pass
Occupied Bandwidth	24.238(b) 2.1049	RSS-GEN 6.6	Pass
Unwanted Emissions at Band Edge	24.238(b) 2.1051	RSS-133 6.5	Pass
Conducted Unwanted Emission	24.238(b) 2.1051	RSS-133 6.5	Pass
Frequency Stability	24.235	RSS-133 6.3	Pass

TEST REPORT**1 GENERAL INFORMATION****1.1 Description of Equipment Under Test (EUT)**

Description:	Remote Radio Unit
Product name:	Radio 4415 B2 B25
Product number:	KRC 161 636/1, KRC 161 636/3
HVIN	AS161636
Serial Number(s)	B440941517
Rating:	-48V DC
Software Version:	PIS: CXP9013268/15_R93CY, UP: CXP9024418/15_R69A46
Hardware Version:	R2B
Sample received date:	January 27, 2023
Date of test:	January 27, 2023 ~ February 3, 2023

TEST REPORT

1.2 Technical Specification

Frequency Range:	B2: TX: 1930-1990 MHz, RX: 1850-1910 MHz B25: TX: 1930-1995 MHz, RX: 1850-1915 MHz
Number of Antenna ports:	4 TX/RX
Supported RAT:	SR/MR: GSM, LTE, WCDMA, NR for B2 SR/MR: LTE, WCDMA, NR for B25
Supported other mode:	/
Max RF bandwidth (IBW):	B2: 60 MHz; B25: 65 MHz
Supported Number of Carriers:	Maximum 6 carriers per port
Supported modulation:	GSM: GMSK, 8PSK, AQPSK WCDMA: QPSK, 16QAM, 64QAM NR/LTE: QPSK, 16QAM, 64QAM, 256QAM
Supported Channel Bandwidth:	GSM/NB-IoT Standalone: 200kHz WCDMA: 5MHz LTE: 1.4, 3, 5, 10, 15, 20 MHz NR: 5, 10, 15, 20, 25, 30, 40 MHz
Declaration output power:	Maximum 40W per port

TEST REPORT

1.3 Description of Test Facility

Name:	Intertek Testing Services Shanghai
Address 1:	Building 86, No. 1198 Qinzhou Road(North), Shanghai 200233, P.R. China
Address 2:	No. 5 Lize East Street, Ericsson Tower, Chaoyang District, Beijing 100102 P.R.C.
Telephone:	+86 21 61278200
Telefax:	+86 21 54262353
The test facility is recognized, certified, or accredited by these organizations:	FCC Accredited Lab Designation Number: CN0175
	IC Registration Lab CAB identifier.: CN0014
	A2LA Accreditation Lab Certificate Number: 3309.02

2 TEST SPECIFICATIONS

2.1 Related documents

FCC Part 24 (2021)
FCC Part 2 (2021)
ISED RSS-133 issue 6 January 2018
ANSI C63.26:2015
KDB 971168 D01 v03r01
KDB 662911 D01 v02r01
SRSP-510

2.2 Product Information

The Equipment Under Test (EUT) is an Ericsson Radio Unit working in the wireless communications services 1930-1995MHz which provides communication connections to network in GSM/WCDMA/LTE/NR modes and MSR modes. The Radio 4415 B2 B25 operates from a -48V DC.

EUT has 2 variants. KRC 161 636/1 without NEBS cover; KRC 161 636/3 with NEBS cover. We test KRC 161 636/1 as typical model and list the worst data.

The EUT includes 4 TX/RX ports and it can be configured to transmit in MIMO mode, and MIMO mode was used for measurements as the worst configuration. The complete testing was performed with the EUT transmitting at maximum RF power unless otherwise stated.

A full technical description can be found in the Manufacturer's documentation.

TEST REPORT

2.3 Configuration Description

The following settings were used to representative for all traffic scenarios when settings with different modulations, channel bandwidths, number for carriers and RF configurations have been tested to find the worst-case setting. The settings below were used for all measurements unless otherwise noted:

NR

Configuration	No. of Carriers	NR Carrier Bandwidth (MHz)	Carrier Frequency Configuration (MHz)		
			Bottom	Middle	Top
NR-1C	1NR	25	1942.5	1962.5	1982.5
		30	1945.0	1962.5	1980.0
		40	1950.0	1962.5	1975.0
NR-2C	2NR	25	-	1942.5+1982.5	-
		30	-	1945+1980	-

NR

Configuration	No. of Carriers	NR Carrier Bandwidth (MHz)	Carrier Frequency Configuration (MHz)		
			Bottom	Middle	Top
NR-1C-BE	1NR	25	1942.5	-	1982.5
		30	1945.0	-	1980.0
		40	1950.0	-	1975.0
NR-2C-BE	2NR	25	1942.5+1967.5	-	1957.5+1982.5
		30	1945+1975	-	1950+1980

TEST REPORT

2.4 Test Setup

Conducted Measurement:

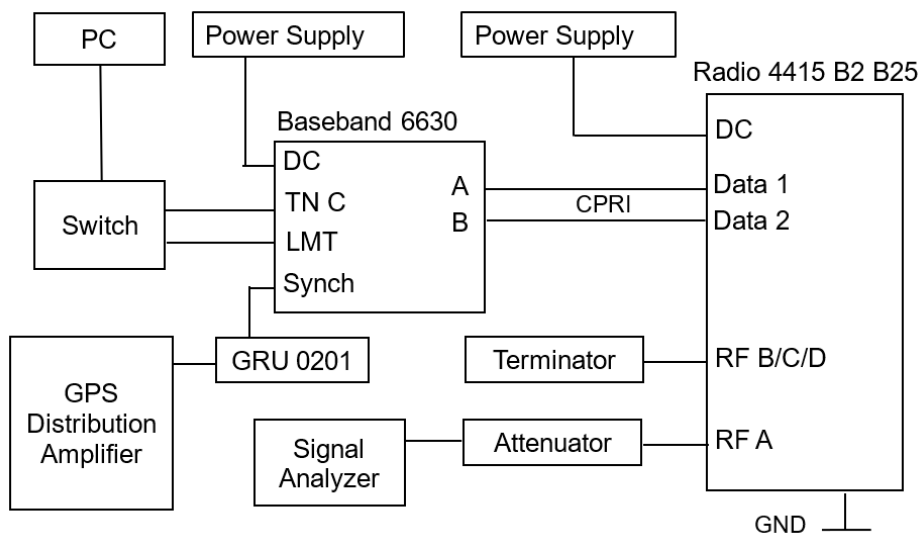

No.	Auxiliary Equipment	Product Number / Model Type	Version
1	PC	PowerEdge R230	-
2	DC Power Supply	N5767A/US17N6926P	-
3	DC Power Supply	N5767A/US22A1518R	-
4	Baseband 6630	KDU 137 848/1	R2F
5	GRU 02 01	NCD 901 41/1	R1E
6	GPS Distribution Amplifier	58536A	-
7	Switch	LS-S5024E-CN	-
8	Terminator	TF100/09121641	-
9	Terminator	TF100/11081908	-
10	Terminator	TF150/08061708	-
11	Attenuator	WDT5150/20101531	-

TEST REPORT**2.5 Test environment condition:**

Test items	Temperature	Humidity
Max Output Power and Peak to Average Power Ratio and EIRP	23°C	54% RH
Occupied Bandwidth		
Unwanted Emissions at Band Edge		
Conducted Unwanted Emission		
Frequency Stability	Please refer to clause 8	

2.6 Instrument list

RF test					
Used	Equipment	Manufacturer	Type	Internal no.	Due date
<input checked="" type="checkbox"/>	PXA Signal Analyzer	Keysight	N9030A	EC1046	2023.4.7
<input type="checkbox"/>	Signal Generator	R&S	SMU200A	EC1050	2023.4.4
<input checked="" type="checkbox"/>	Climatic Chamber	赛宝	117	EC1052	2023.9.19
<input type="checkbox"/>	Humiture meter	托普	CEEC-WR16H-50W	EC1053	2023.2.21
<input type="checkbox"/>	Power sensor	R&S	TPJ-20	EC1111	2023.7.14
<input type="checkbox"/>	Power sensor	R&S	NRP-Z11	EC1112	2023.7.14
<input type="checkbox"/>	Power meter	R&S	NRP-Z21	EC1113	2023. 8.9

TEST REPORT**2.7 Measurement uncertainty**

The measurement uncertainty represents an expanded uncertainty expressed at approximately the 95% confidence level using a coverage factor of k=2.

Test item	Measurement uncertainty
Maximum output power	0.73dB
Occupied Bandwidth	0.88%
Unwanted Emissions at Band Edge	3.03dB
Conducted Unwanted Emission	3.03dB
Frequency stability	0.77×10^{-7}

TEST REPORT

3 Maximum Output Power and Peak to Average Power Ratio and EIRP

Test result: Pass

3.1 Limit

Output Power: Base stations with an emission bandwidth greater than 1 MHz are limited to 1640 watts/MHz equivalent isotropically radiated power (EIRP) with an antenna height up to 300 meters HAAT

Peak to Average Ratio: ≤ 13 dB

3.2 Measurement Procedure

The EUT was configured to transmit on maximum power and proper modulation. The transmitter power shall be measured in terms of a root-mean-square (RMS) average value. In case of the EUT was configured to MIMO mode, since the EUT transmits on all antennas simultaneously in the same frequency range, using the Measure-and-Sum approach, the output power at all antennas were tested, and the total output power were then summed mathematically in linear power units according to FCC KDB 662911 D01.

A peak to average ratio measurement is performed at the conducted ports of the EUT for single carrier for single RAT mode. The spectrum analyzers Complementary Cumulative Distribution Function (CCDF) was used and 0.1% probability value recorded.

TEST REPORT

3.3 Measurement result

NR mode:

NR-1C

Antenna Port	NR Modulation	NR Carrier Bandwidth (MHz)	Output power / Peak-to-Average Ratio (PAR)								
			Channel position B			Channel position M			Channel position T		
			Power (dBm)	Power (dBm /MHz)	PAR (dB)	Power (dBm)	Power (dBm /MHz)	PAR (dB)	Power (dBm)	Power (dBm /MHz)	PAR (dB)
A	256QAM	25	45.31	32.26	7.58	45.84	32.51	7.24	45.80	32.60	7.38
B	256QAM	25	45.20	32.07	7.57	45.72	32.45	7.24	45.66	32.42	7.39
C	256QAM	25	45.14	32.04	7.59	45.72	32.39	7.24	45.66	32.26	7.36
D	256QAM	25	45.14	31.96	7.54	45.63	32.38	7.24	45.59	32.30	7.36
Total conducted power			51.22	38.10	-	51.75	38.45	-	51.70	38.42	-
EIRP limit			-	62.15	13.00	-	62.15	13.00	-	62.15	13.00
Max antenna gain			-	24.05	-	-	23.70	-	-	23.73	-

Antenna Port	NR Modulation	NR Carrier Bandwidth (MHz)	Output power / Peak-to-Average Ratio (PAR)								
			Channel position B			Channel position M			Channel position T		
			Power (dBm)	Power (dBm /MHz)	PAR (dB)	Power (dBm)	Power (dBm /MHz)	PAR (dB)	Power (dBm)	Power (dBm /MHz)	PAR (dB)
A	256QAM	30	45.57	31.57	7.18	45.92	31.79	6.50	45.88	31.78	6.82
B	256QAM	30	45.52	31.52	7.18	45.77	31.71	6.50	45.78	31.69	6.84
C	256QAM	30	45.43	31.45	7.23	45.72	31.64	6.62	45.73	31.60	6.77
D	256QAM	30	45.36	31.38	7.19	45.67	31.57	6.50	45.69	31.58	6.78
Total conducted power			51.49	37.50	-	51.79	37.70	-	51.79	37.68	-
EIRP limit			-	62.15	13.00	-	62.15	13.00	-	62.15	13.00
Max antenna gain			-	24.65	-	-	24.45	-	-	24.47	-

Antenna Port	NR Modulation	NR Carrier Bandwidth (MHz)	Output power / Peak-to-Average Ratio (PAR)								
			Channel position B			Channel position M			Channel position T		
			Power (dBm)	Power (dBm /MHz)	PAR (dB)	Power (dBm)	Power (dBm /MHz)	PAR (dB)	Power (dBm)	Power (dBm /MHz)	PAR (dB)
A	256QAM	40	45.71	30.30	7.76	45.90	30.35	7.32	45.82	30.40	7.42
B	256QAM	40	45.60	30.24	7.77	45.60	30.10	7.32	45.71	30.14	7.42
C	256QAM	40	45.55	30.32	7.82	45.67	30.32	7.32	45.65	30.12	7.38
D	256QAM	40	45.58	30.23	7.80	45.61	30.13	7.32	45.71	30.17	7.39
Total conducted power			51.63	36.29	-	51.72	36.25	-	51.74	36.23	-
EIRP limit			-	62.15	13.00	-	62.15	13.00	-	62.15	13.00
Max antenna gain			-	25.86	-	-	25.90	-	-	25.92	-

TEST REPORT

NR-2C

Antenna Port	NR Modulation	NR Carrier Bandwidth (MHz)	Output power / Peak-to-Average Ratio (PAR)								
			Channel position B			Channel position M			Channel position T		
			Power (dBm)	Power (dBm /MHz)	PAR (dB)	Power (dBm)	Power (dBm /MHz)	PAR (dB)	Power (dBm)	Power (dBm /MHz)	PAR (dB)
A	256QAM	25	-	-	-	45.50	29.33	-	-	-	-
B	256QAM	25	-	-	-	45.32	29.25	-	-	-	-
C	256QAM	25	-	-	-	45.40	29.23	-	-	-	-
D	256QAM	25	-	-	-	45.37	29.16	-	-	-	-
Total conducted power			-	-	-	51.42	35.26	-	-	-	-
EIRP limit			-	-	-	-	62.15	-	-	-	-
Max antenna gain			-	-	-	-	26.89	-	-	-	-

Antenna Port	NR Modulation	NR Carrier Bandwidth (MHz)	Output power / Peak-to-Average Ratio (PAR)								
			Channel position B			Channel position M			Channel position T		
			Power (dBm)	Power (dBm /MHz)	PAR (dB)	Power (dBm)	Power (dBm /MHz)	PAR (dB)	Power (dBm)	Power (dBm /MHz)	PAR (dB)
A	256QAM	30	-	-	-	45.63	28.65	-	-	-	-
B	256QAM	30	-	-	-	45.37	28.46	-	-	-	-
C	256QAM	30	-	-	-	45.80	28.49	-	-	-	-
D	256QAM	30	-	-	-	45.36	28.42	-	-	-	-
Total conducted power			-	-	-	51.56	34.53	-	-	-	-
EIRP limit			-	-	-	-	62.15	-	-	-	-
Max antenna gain			-	-	-	-	27.62	-	-	-	-

TEST REPORT**4 Occupied Bandwidth****Test result: Pass****4.1 Measurement Procedure**

The EUT was set to transmit at maximum power and testing was carried out on bottom, middle and top channels. Using the Occupied Bandwidth measurement function in the spectrum analyzer, the 26dB bandwidth was measured in accordance with FCC KDB 971168 D01 Clause 4.2.

The measurement method is from KDB 971168 4.2:

- a) The spectrum analyzer center frequency is set to the nominal EUT channel center frequency. The frequency span for the spectrum analyzer shall be set wide enough to capture all modulation products including the emission skirts (i.e., two to five times the OBW).
- b) The nominal IF filter bandwidth (3 dB RBW) shall be in the range of 1 to 5 % of the anticipated OBW, and the VBW shall be at least 3 times the RBW.
- c) Set the reference level of the instrument as required to keep the signal from exceeding the maximum input mixer level for linear operation. In general, the peak of the spectral envelope must be at least $10\log(\text{OBW} / \text{RBW})$ below the reference level.
- d) Set the detection mode to peak, and the trace mode to max hold.
- e) Use the 99 % power bandwidth function of the spectrum analyzer and report the measured bandwidth.

TEST REPORT

4.2 Measurement result

NR-1C

99% Occupied Bandwidth

Antenna Port	Modulation	Bandwidth	Occupied Bandwidth (MHz)		
			Channel Position B	Channel Position M	Channel Position T
A	256QAM	25MHz	23.691	23.708	23.693
A	256QAM	30MHz	28.454	28.461	28.467
A	256QAM	40MHz	38.503	38.527	38.542

-26dBc Occupied Bandwidth

Antenna Port	Modulation	Bandwidth	Occupied Bandwidth (MHz)		
			Channel Position B	Channel Position M	Channel Position T
A	256QAM	25MHz	24.70	24.76	24.75
A	256QAM	30MHz	29.49	29.42	29.43
A	256QAM	40MHz	40.02	40.03	41.19

256QAM, 25MHz, Channel position B

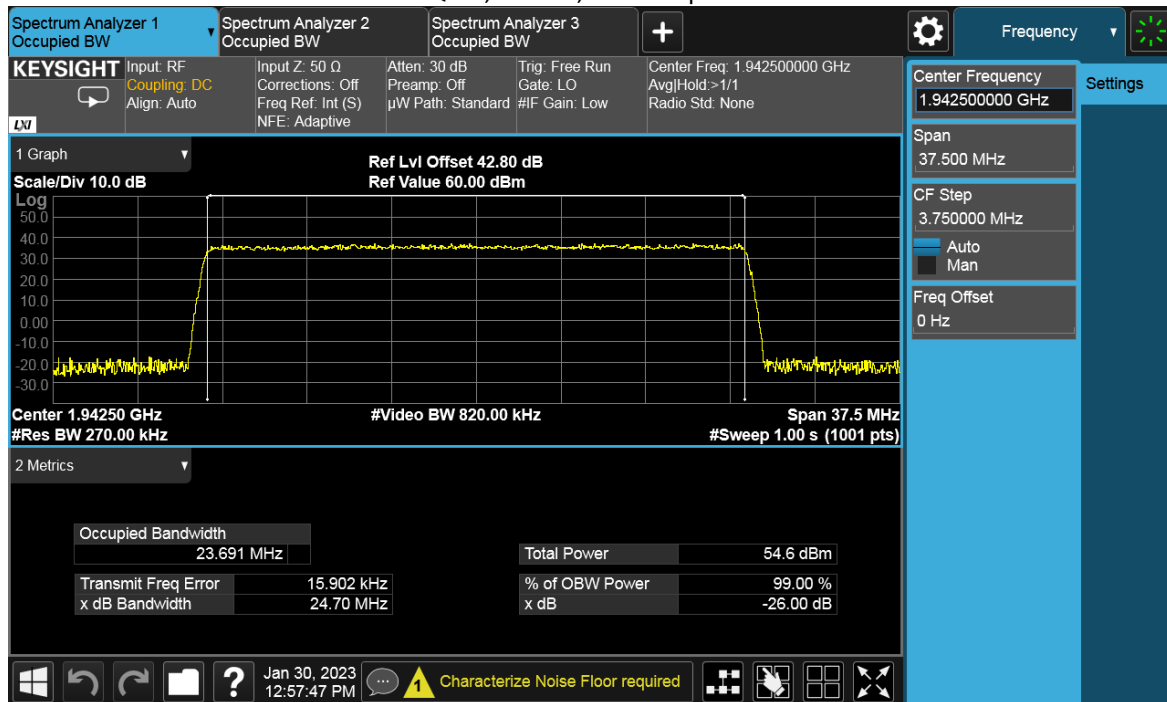

256QAM, 25MHz, Channel position M

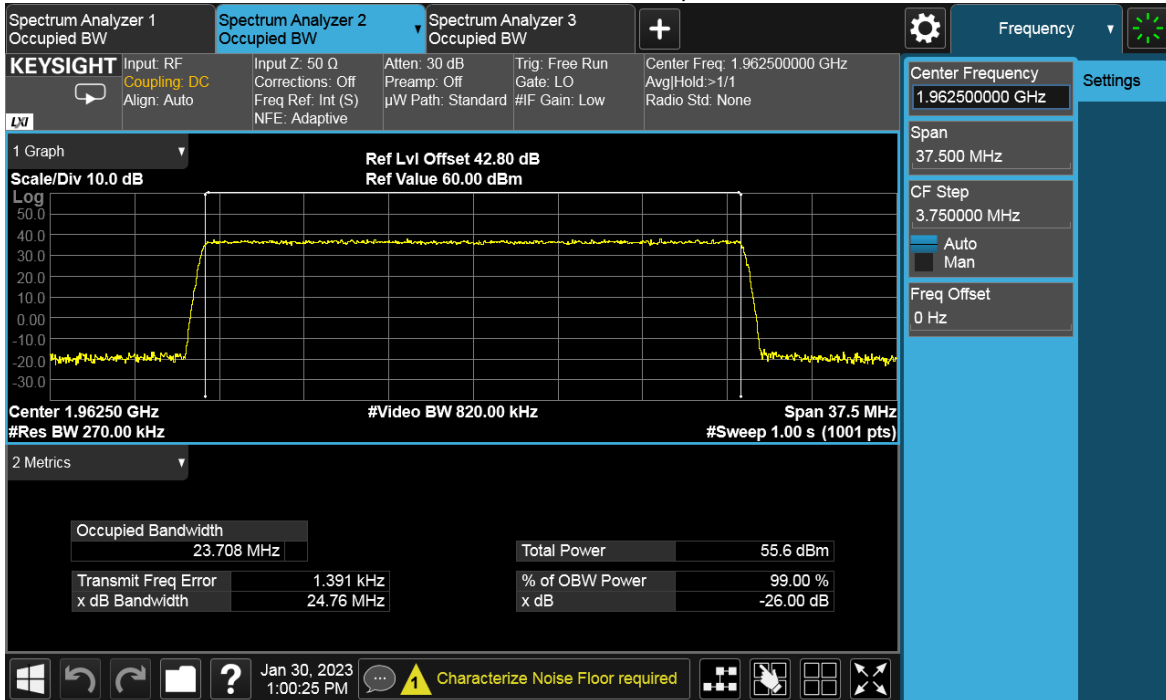

256QAM, 25MHz, Channel position T

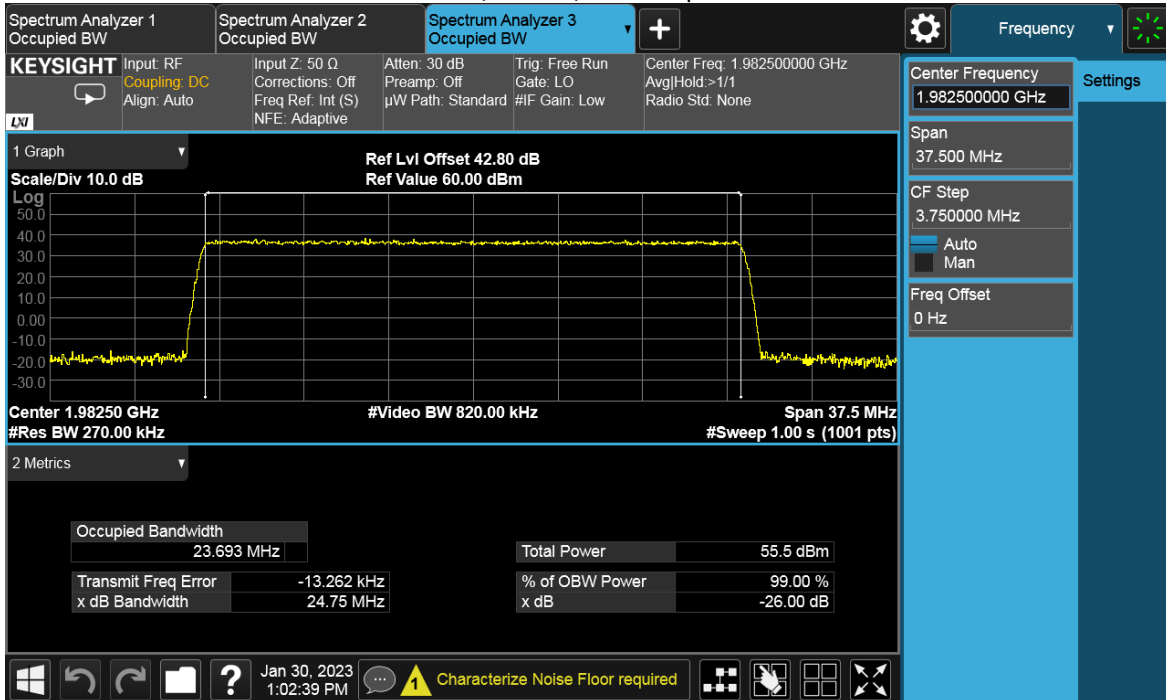

256QAM, 30MHz, Channel position B

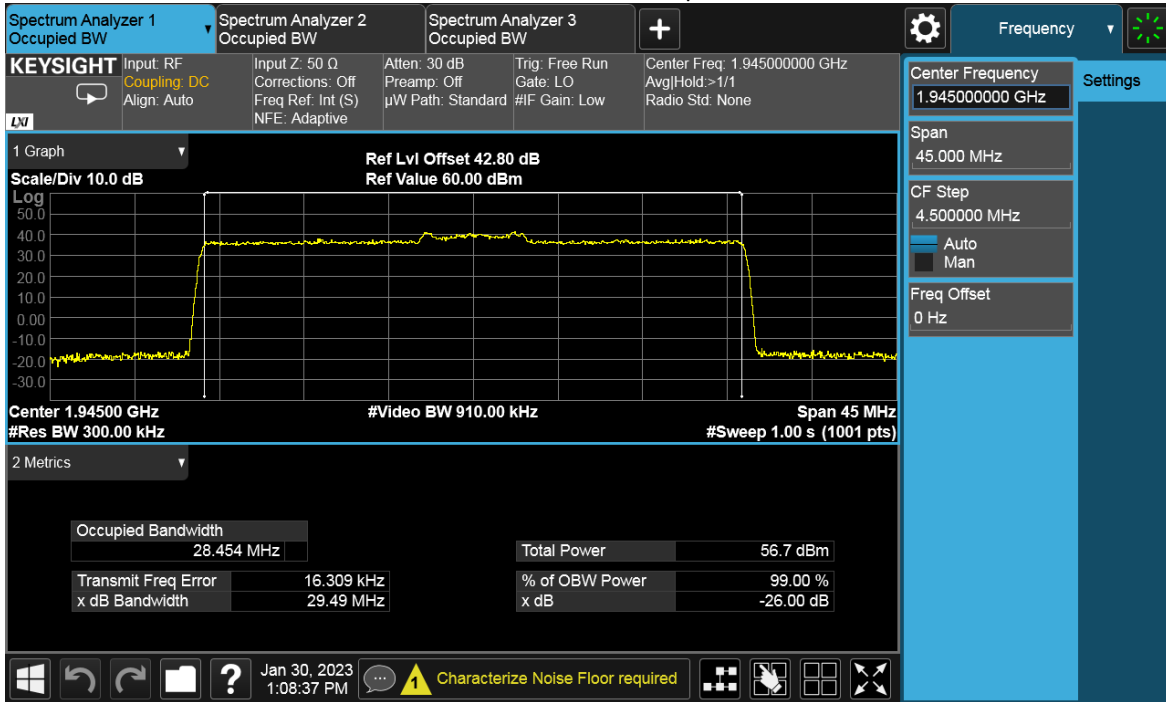

256QAM, 30MHz, Channel position M

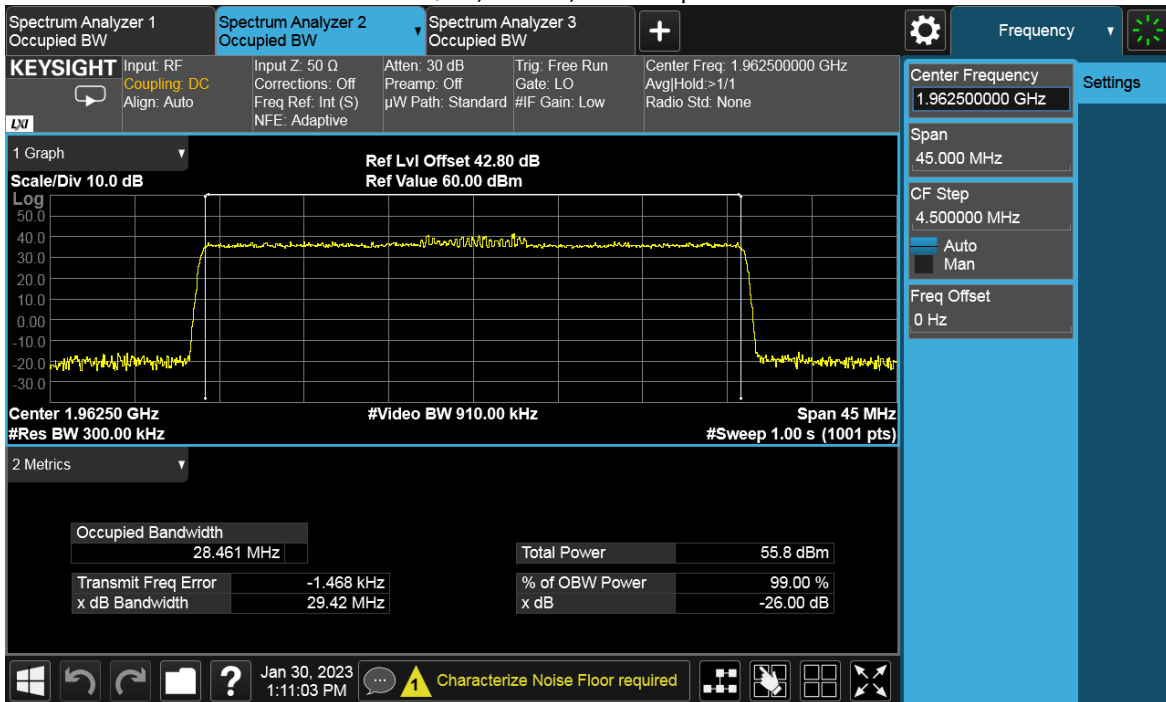

256QAM, 30MHz, Channel position T

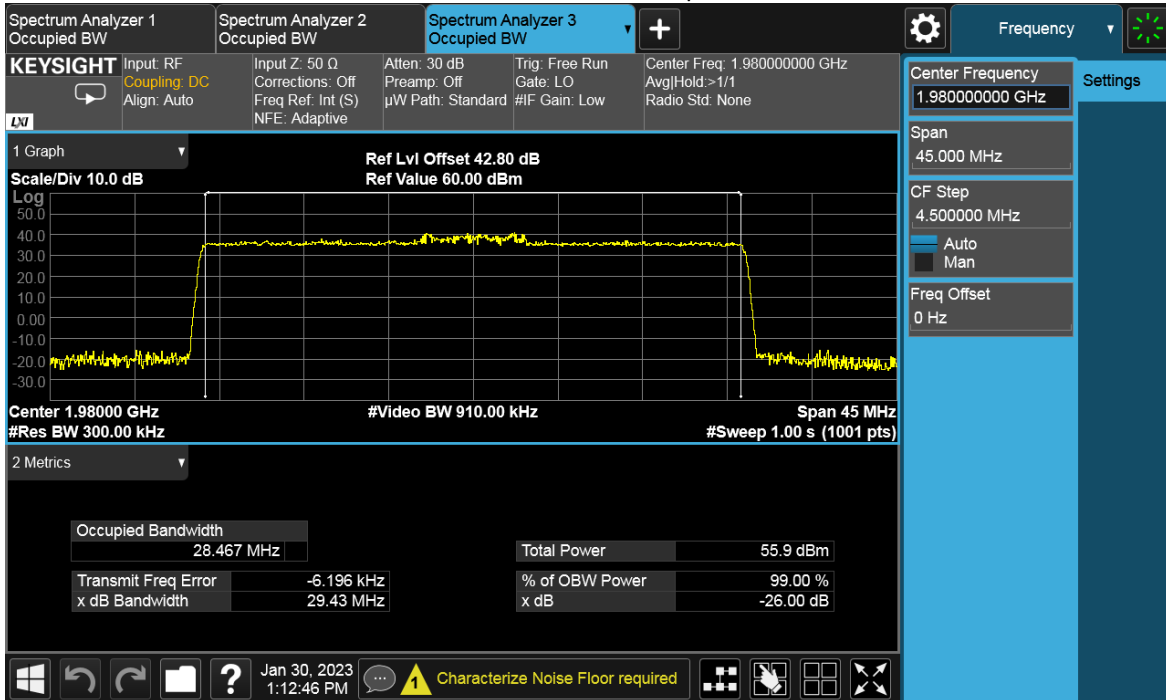

256QAM, 40MHz, Channel position B

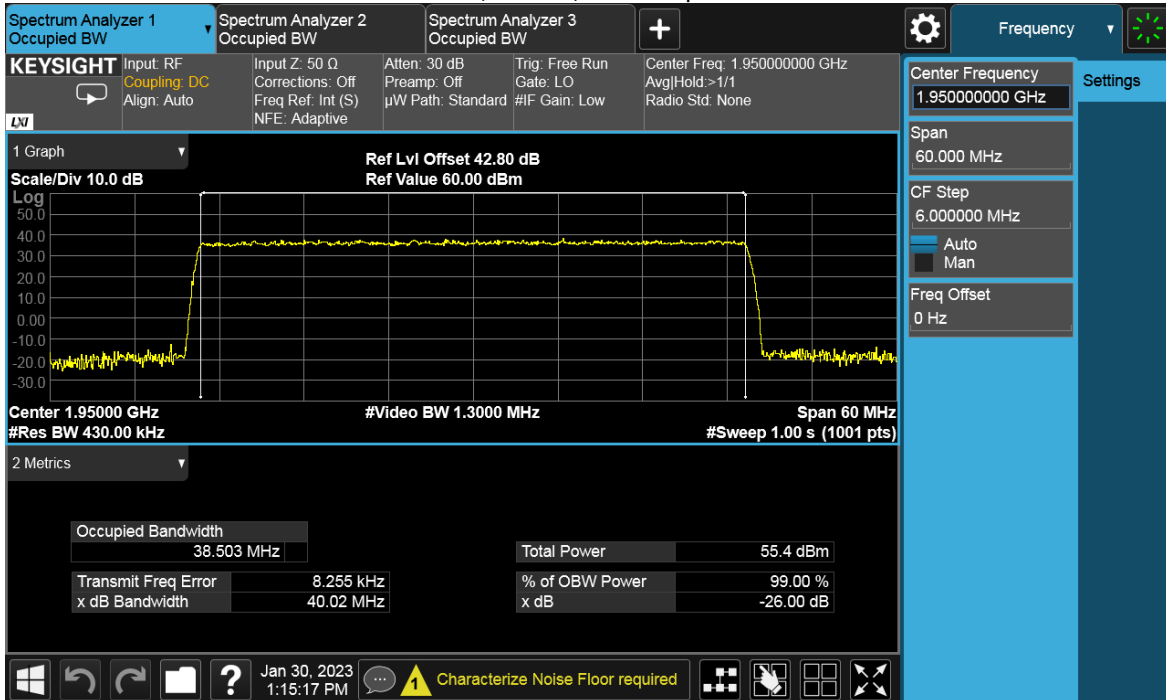

256QAM, 40MHz, Channel position M

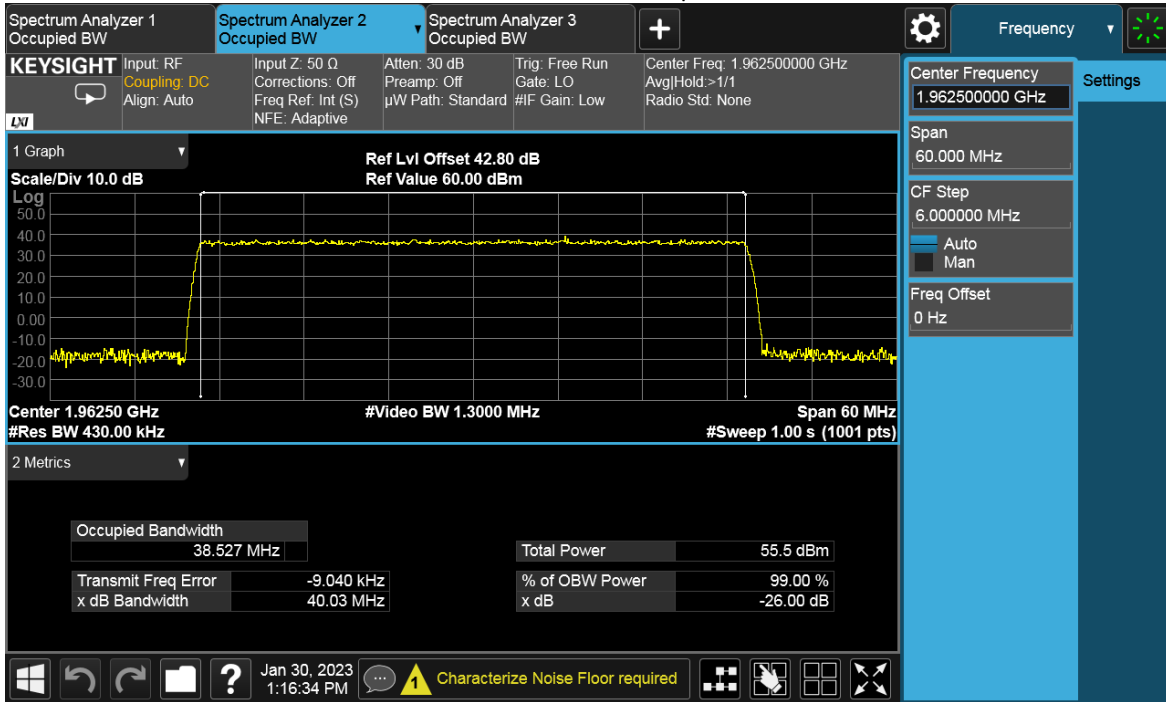

256QAM, 40MHz, Channel position T

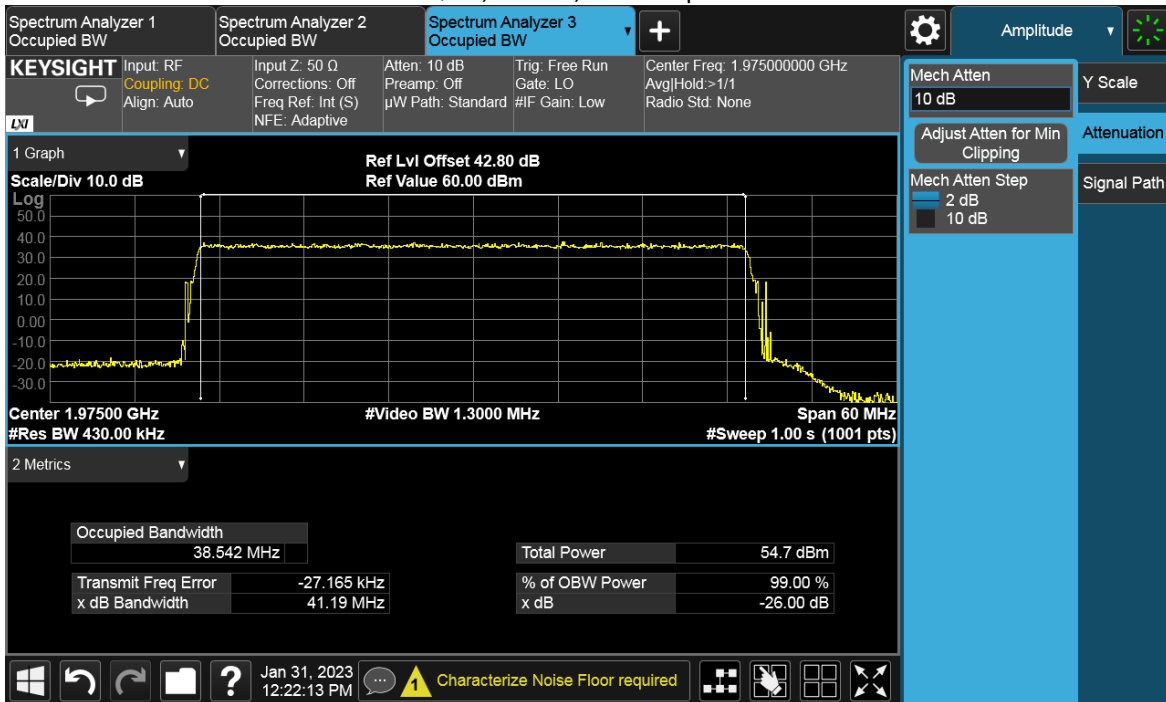

TEST REPORT**5 Unwanted Emissions at Band Edge****Test result:** Pass**5.1 Limit**

The power of any emission outside of the authorized operating frequency ranges must be attenuated below the transmitting power (P) by a factor of at least $43 + 10\log(P)$ dB.

5.2 Measurement Procedure

The power of any emission outside of the authorized operating frequency ranges must be attenuated below the transmitting power (P) by a factor of at least $43 + 10\log(P)$ dB.

For MIMO mode configurations, the limit was adjusted with a correction of -6.02dB [$10\log(1/4)$] by using the Measure and Add $10\log(N)$ dB technique according to KDB 662911 D01 Multiple Transmitter Output accounting for simultaneous transmission from antenna ports . Then the limit was adjusted to -19.02dBm .

In the 1 MHz bands immediately outside and adjacent to the frequency block, a resolution bandwidth of at least one percent of the emission bandwidth of the fundamental emission of the transmitter may be employed and a RBW of 1MHz for measurements of emissions $> 1\text{MHz}$ away from the band edges.

Spectrum analyzer detector was set as RMS.

TEST REPORT

5.3 Measurement result

NR-1C-BE

Antenna Port	Channel Position	Modulation	Carrier BW (MHz)	RBW (kHz)	Limit (dBm)
A	B	256QAM	25	270	-19.02
A	T	256QAM	25	270	-19.02

Channel Position B

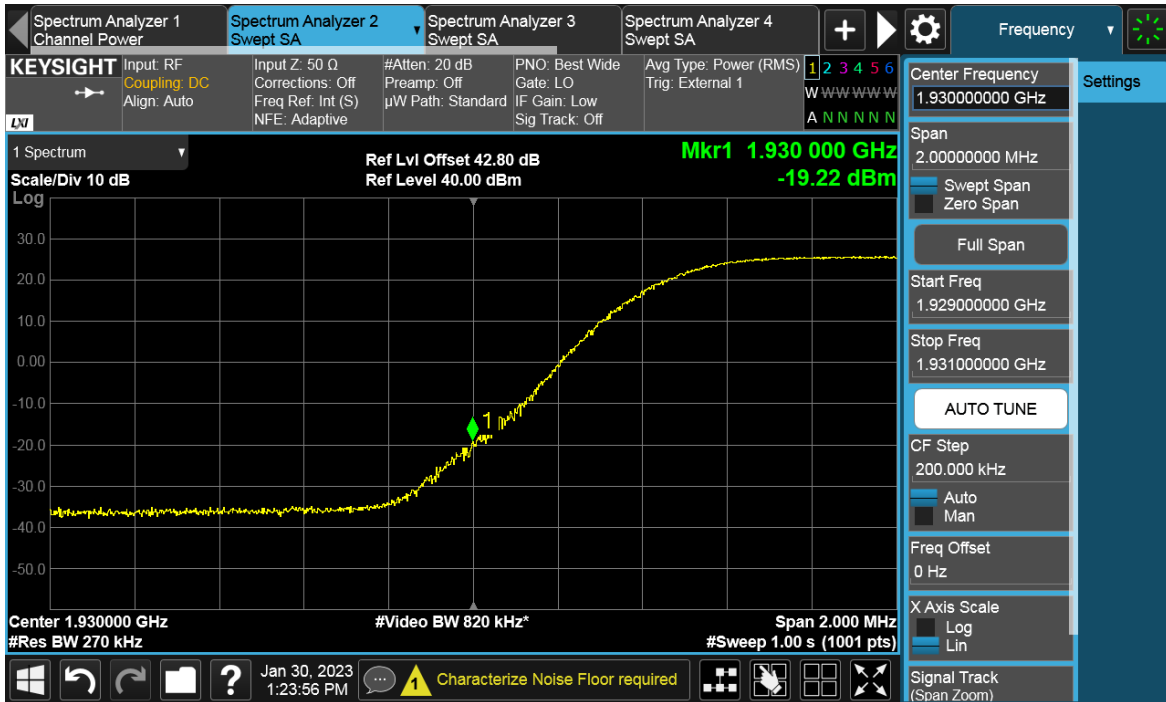

Channel Position T

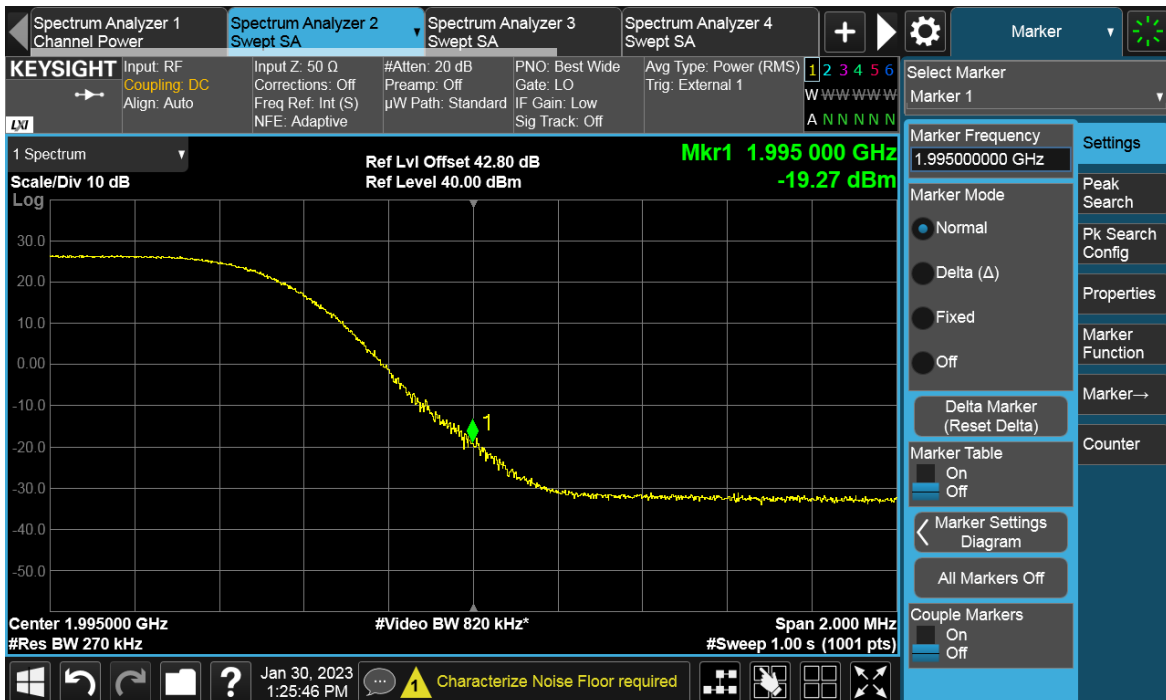

TEST REPORT

Antenna Port	Channel Position	Modulation	Carrier BW (MHz)	RBW (kHz)	Limit (dBm)
A	B	256QAM	30	300	-19.02
A	T	256QAM	30	300	-19.02

Channel Position B

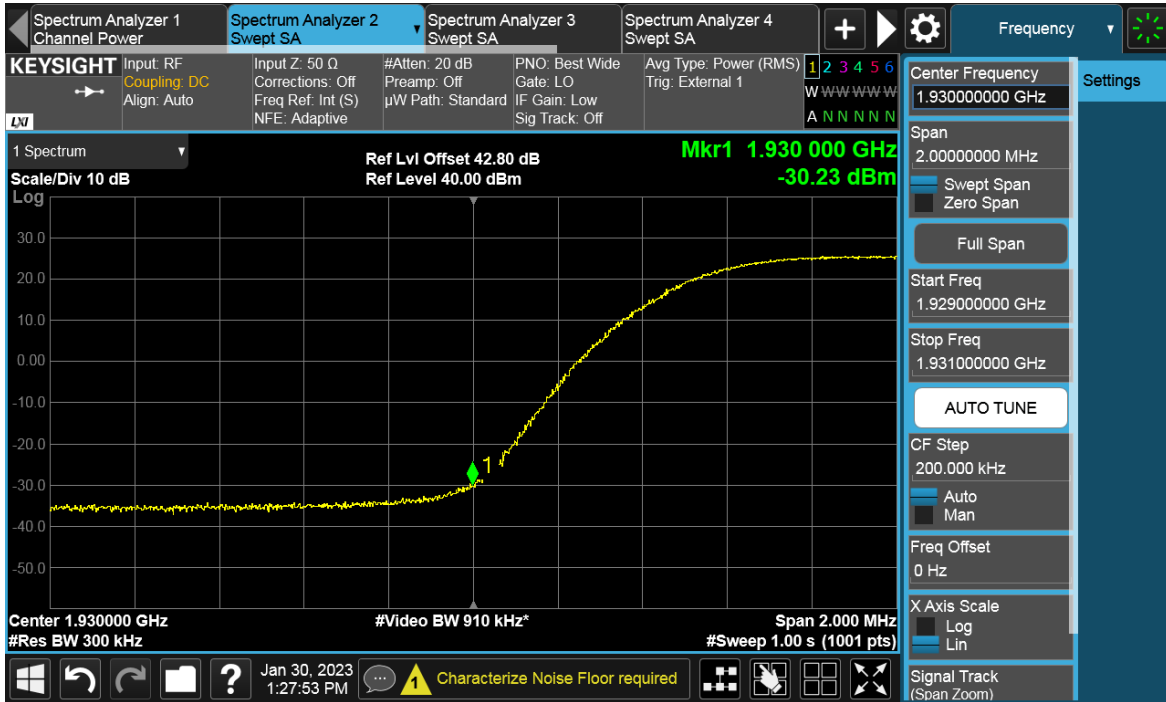

Channel Position T



TEST REPORT

Antenna Port	Channel Position	Modulation	Carrier BW (MHz)	RBW (kHz)	Limit (dBm)
A	B	256QAM	40	430	-19.02
A	T	256QAM	40	430	-19.02

Channel Position B

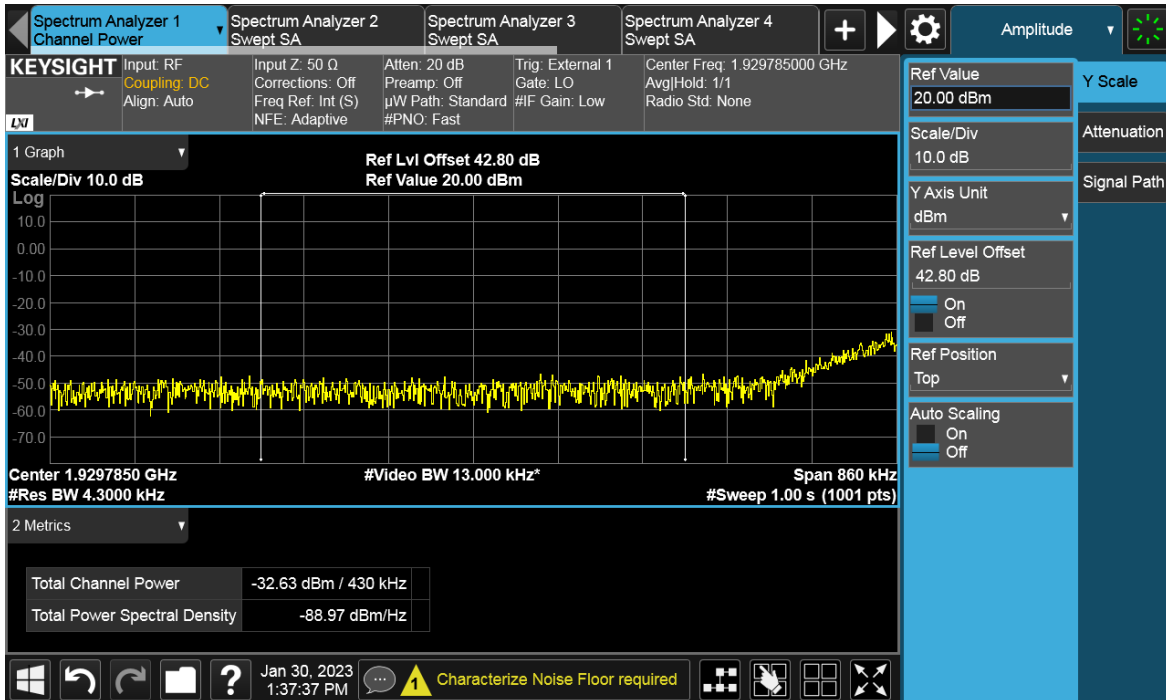
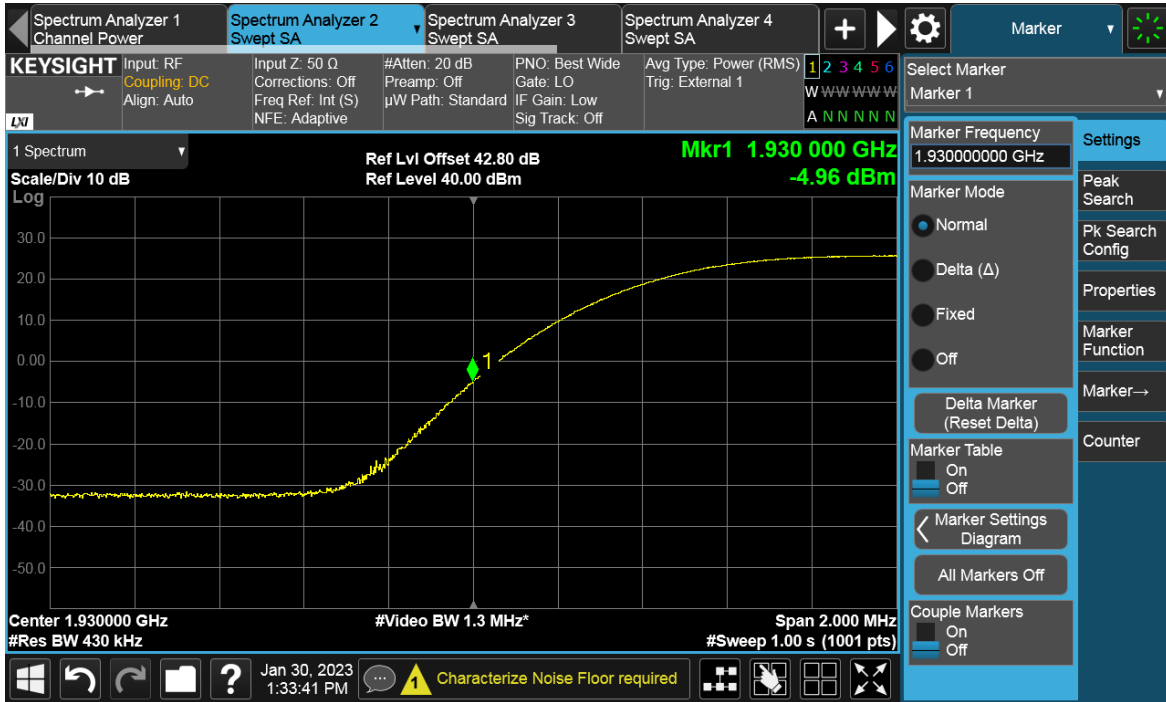

Channel Position T

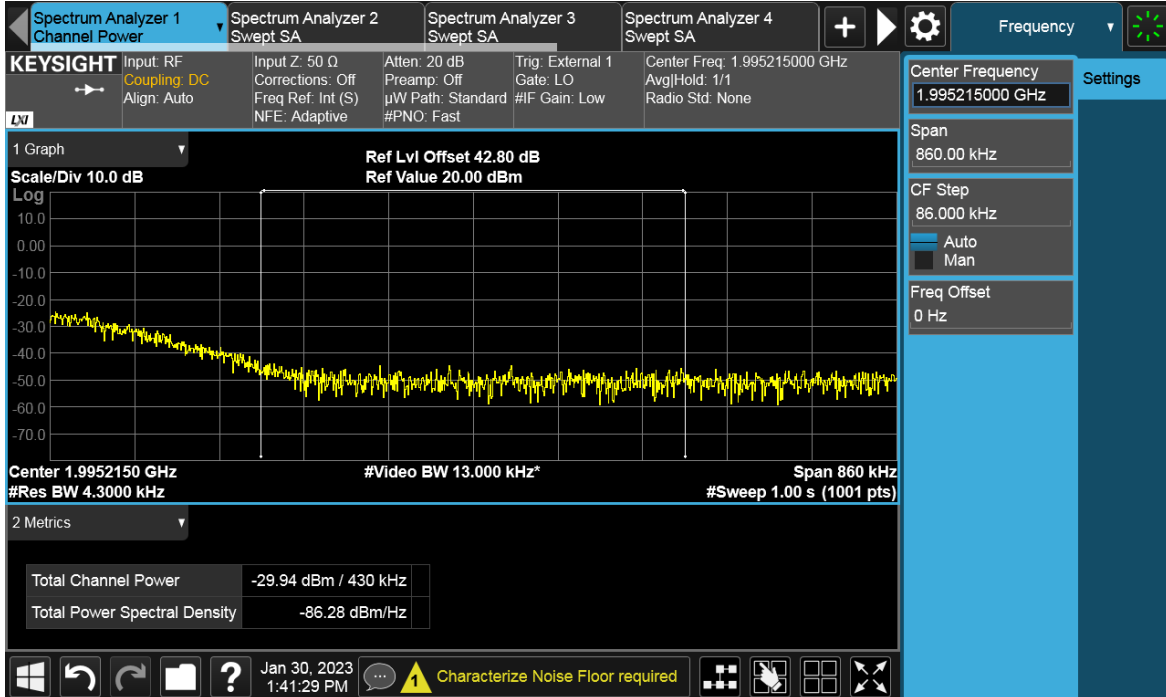

TEST REPORT

NR-2C-BE

Antenna Port	Channel Position	Modulation	Carrier BW (MHz)	RBW (kHz)	Limit (dBm)
A	B	256QAM	25	270	-19.02
A	T	256QAM	25	270	-19.02

Channel Position B

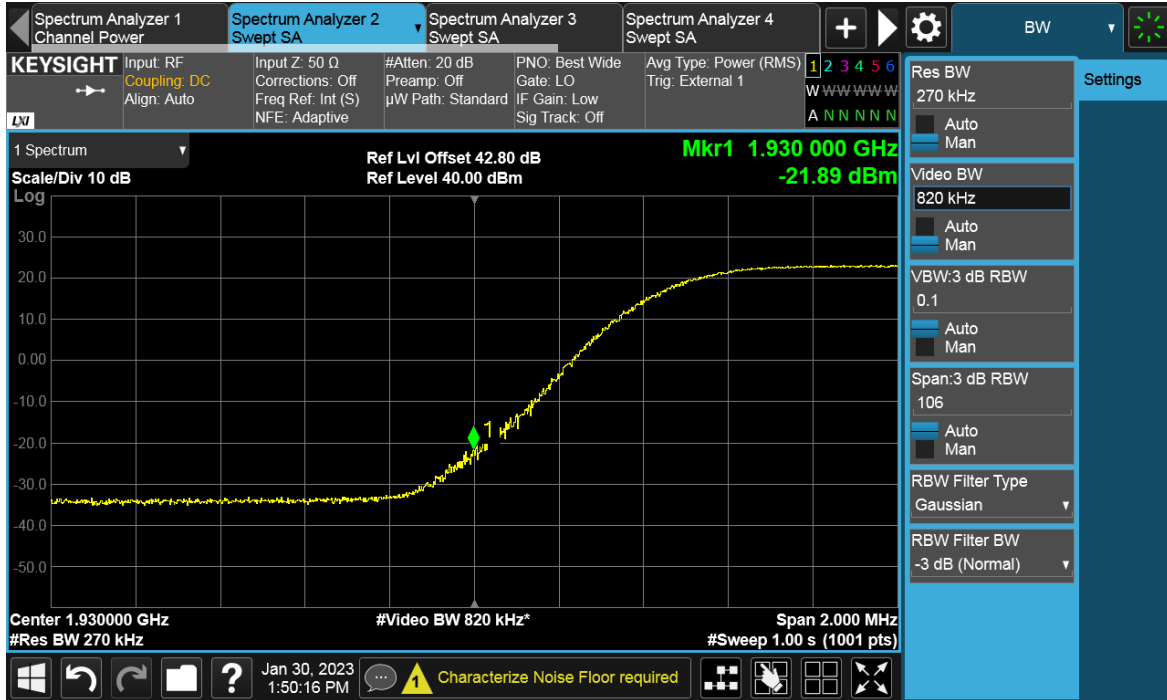

Channel Position T



TEST REPORT

Antenna Port	Channel Position	Modulation	Carrier BW (MHz)	RBW (kHz)	Limit (dBm)
A	B	256QAM	30	300	-19.02
A	T	256QAM	30	300	-19.02

Channel Position B

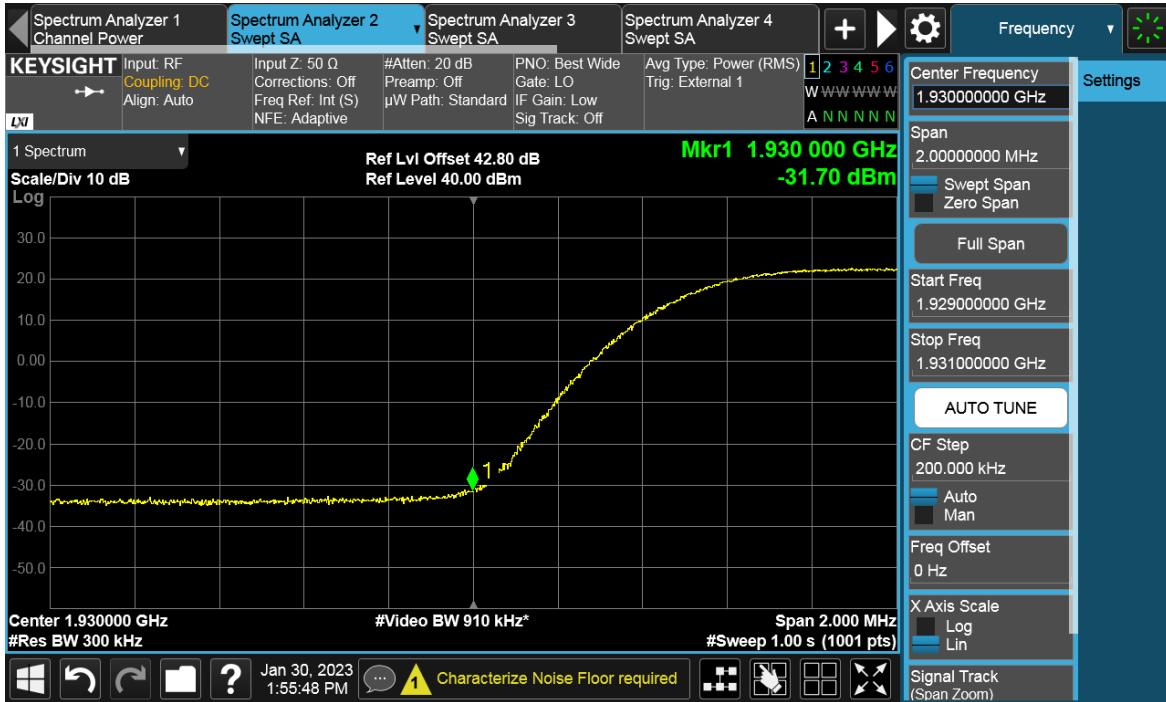

Channel Position T

