



427 West 12800 South
Draper, UT 84020

Test Report Certification

FCC ID	SWX-U7PRO
ISED ID	6545A-U7PRO
Equipment Under Test	U7-Pro
Test Report Serial Number	TR8554_04
Date of Test(s)	30 August; 1, 8, 19 September and 12, 16 October 2023
Report Issue Date	12 December 2023

Test Specification	Applicant
47 CFR FCC Part 15, Subpart E	Ubiquiti Inc. 685 Third Avenue New York, NY 10017 U.S.A.



NVLAP LAB CODE 600241-0

Certification of Engineering Report

This report has been prepared by Unified Compliance Laboratory (UCL) to document compliance of the device described below with the requirement of Federal Communication Commissions (FCC) Part 15, Subpart E. This report may be reproduced in full. Partial reproduction of this report may only be made with the written consent of the laboratory. The results in this report apply only to the sample tested.

Applicant	Ubiquiti Inc.
Manufacturer	Ubiquiti Inc.
Brand Name	UBIQUITI
Model Number	U7-Pro
FCC ID	SWX-U7PRO
ISED ID	6545A-U7PRO

On this 12th day of December 2023, I individually and for Unified Compliance Laboratory certify that the statements made in this engineering report are true, complete, and correct to the best of my knowledge and are made in good faith.

Although NVLAP has accredited the Unified Compliance Laboratory testing facilities, this report must not be used to claim product certification, approval, or endorsement by NVLAP, NIST or any agency of the U.S. federal government.

Unified Compliance Laboratory



Written By: Joseph W. Jackson



Reviewed By: Richard L. Winter

Revision History		
Revision	Description	Date
01	Original Report Release	17 October 2023
02	Amend Sections 5.1 and 5.6	24 October 2023
03	Updated Section 5.1 for beamforming gain and Section 2.10 for channel puncturing and RU considerations.	7 December 2023
04	Added CBP Test Equipment to Section 4, RE diagrams to Section 4.3, RU test Data to section 5.6, updated CBP test procedure to include 0dBi antenna gain in section 5.7	12 December 2023

Table of Contents

1	Client Information.....	5
1.1	Applicant.....	5
1.2	Manufacturer.....	5
2	Equipment Under Test (EUT).....	6
2.1	Identification of EUT.....	6
2.2	Description of EUT.....	6
2.3	EUT and Support Equipment.....	6
2.4	Interface Ports on EUT.....	7
2.5	Operating Environment.....	7
2.6	Operating Modes.....	7
2.7	EUT Exercise Software.....	7
2.8	Block Diagram of Test Configuration.....	8
2.9	Modification Incorporated/Special Accessories on EUT.....	8
2.10	Deviation, Opinions Additional Information or Interpretations from Test Standard.....	8
3	Test Specification, Method and Procedures.....	9
3.1	Test Specification.....	9
3.2	Methods & Procedures.....	9
3.3	FCC Part 15, Subpart E.....	9
3.4	Results.....	9
3.5	Test Location.....	10
4	Test Equipment.....	11
4.1	Conducted Emissions at Mains Ports.....	Error! Bookmark not defined.
4.2	Direct Connect at the Antenna Port Tests.....	Error! Bookmark not defined.
4.3	Radiated Emissions.....	Error! Bookmark not defined.
4.4	Equipment Calibration.....	11
4.5	Measurement Uncertainty.....	14
5	Test Results.....	15
5.1	§15.203 Antenna Requirements.....	15
5.2	Conducted Emissions at Mains Ports Data.....	16
5.3	§15.403(i) 26 dB Emissions Bandwidth.....	18
5.4	§15.407(a)(3) Maximum Average Output Power.....	19
5.5	§15.407(b)(7) Spurious Emissions.....	20
5.6	§15.407(a) Maximum Power Spectral Density.....	26
5.7	§15.407(d) Contention Based Protocol.....	31

1 Client Information

1.1 Applicant

Company	Ubiquiti Inc. 685 Third Avenue New York, NY 10017 U.S.A.
Contact Name	Alex Macon
Title	Compliance

1.2 Manufacturer

Company	Ubiquiti Inc. 685 Third Avenue New York, NY 10017 U.S.A.
Contact Name	Alex Macon
Title	Compliance

2 Equipment Under Test (EUT)

2.1 Identification of EUT

Brand Name	UBIQUITI
Model Number	U7-PRO
Serial Number	9AZ 003
Dimensions (cm)	20.6 x 20.6 x 4.6

2.2 Description of EUT

The U7-Pro is WiFi 7 access point that represents the next generation of competitively priced, prosumer wireless technology for home and enterprise users. The U7-Pro provides high aggregate throughput speeds. The U7-Pro transmit in the 2.4 GHz, 5 GHz and 6 GHz frequency bands and uses integrated antennas. The U7-Pro is powered from an 802.3at power adapter.

This report covers the circuitry of the device subject to FCC Part 15, Subpart E. The circuitry of the device subject to FCC Part 15 Subpart B was found to be compliant and is covered under a separate Unified Compliance Laboratory test report.

The table below show the channels used within the different modulation bandwidths.

Band	Modulation Bandwidth	Frequency (MHz)	Maximum Power Setting
UNII-6	EHT 20 MHz	6435	TP 10
		6475	TP 10
		6515	TP 10
	EHT 40 MHz	6445	TP 13
		6485	TP 13
	EHT 80 MHz	6465	TP 16
EHT 160 MHz	6505	TP 19	

2.3 EUT and Support Equipment

The EUT and support equipment used during the test are listed below.

Brand Name Model Number Serial Number	Description	Name of Interface Ports / Interface Cables
BN: UBIQUITI MN: U7-Pro SN: 9AZ 003	WiFi Access Point	See Section 2.4

BN: UBIQUITI MN: U-POE-at SN: N/A	PoE Power Adapter	Unshielded Cat 5e cable/1 meters
BN: Dell MN: XPS 13 SN: N/A	Laptop Personal Computer	Unshielded Cat 5e cable/1 meters

Notes: (1) EUT

(2) Interface port connected to EUT (See Section 2.4)

The support equipment listed above was not modified in order to achieve compliance with this standard.

2.4 Interface Ports on EUT

Name of Ports	No. of Ports Fitted to EUT	Cable Description/Length
AC Mains	1	3 conductor power cord/80 cm
POE (POE Injector)	1	Unshielded Cat 5e cable/8 meters
LAN (POE Injector)	1	Unshielded Cat 5e cable/1 meters

2.5 Operating Environment

Power Supply	120 Volts AC Mains to 48 Volts PoE
AC Mains Frequency	60 Hz
Temperature	24.7 – 26.4 °C
Humidity	30.4 – 35.9 %
Barometric Pressure	1017 mBar

2.6 Operating Modes

The U7-Pro was tested using test software in order to enable to constant transmission. The measurements within this report are corrected to reference a 100% duty cycle. All emission modes of 802.11be were investigated. All measurements are reported with the worst-case mode (802.11be) unless otherwise stated.

2.7 EUT Exercise Software

EUT firmware version 1.0 was used to operate the transmitter using a constant transmit mode.

2.8 Block Diagram of Test Configuration

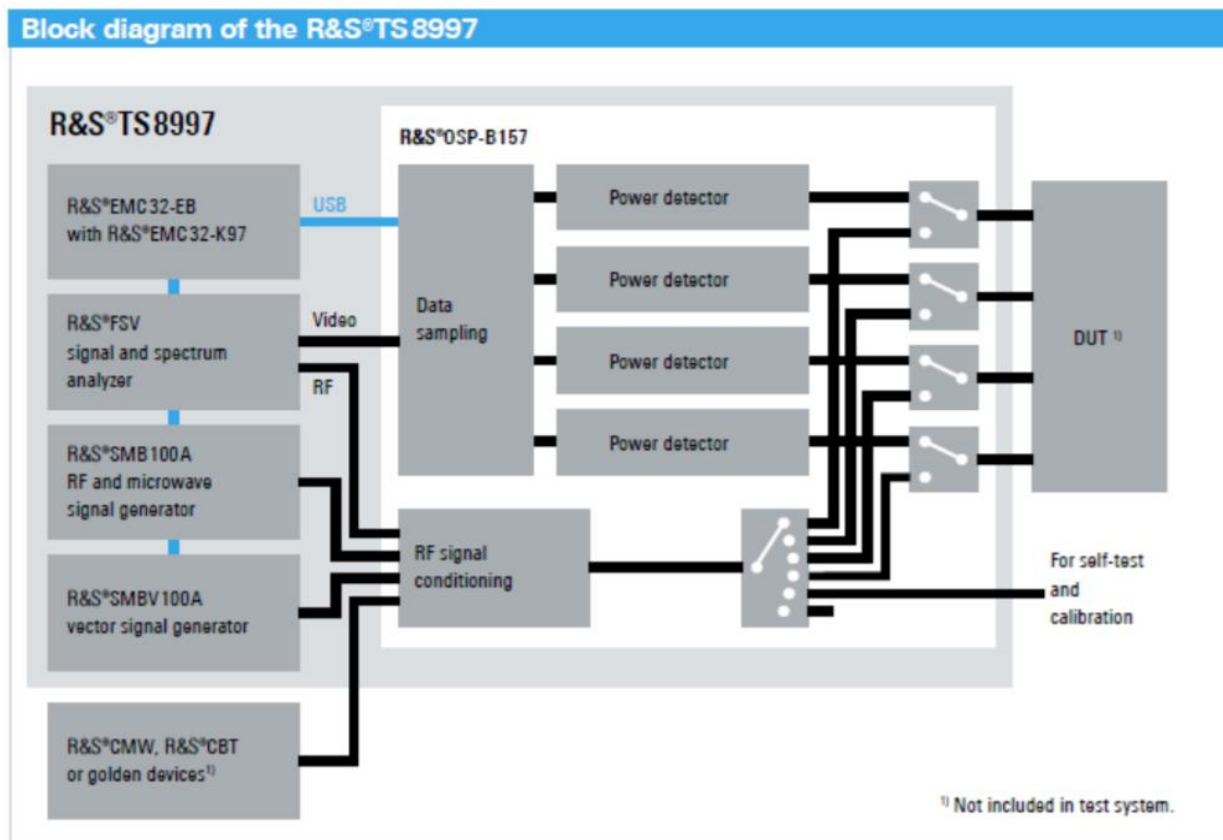

Diagram 1: Test Configuration Block Diagram

2.9 Modification Incorporated/Special Accessories on EUT

There were no modifications made to the EUT during testing to comply with the specification.

2.10 Deviation, Opinions Additional Information or Interpretations from Test Standard

Per the manufacturer the U7-Pro does not support channel puncturing and considerations noted in KDB 987594 D02 per we not applicable. Additionally, partially populated DL OFDMA packets are not supported. Therefore, testing of the packet type uses fully modulated packets. The partially modulated waveforms per KDB 987594 D04 is not applicable for this product.

3 Test Specification, Method and Procedures

3.1 Test Specification

Title	47 CFR FCC Part 15, Subpart E, Section 15.407 Limits and methods of measurement of radio interference characteristics of Unlicensed National Information Infrastructure Devices
Purpose of Test	The tests were performed to demonstrate initial compliance

3.2 Methods & Procedures

3.2.1 47 CFR FCC Part 15 Section 15.407

See test standard for details.

3.3 FCC Part 15, Subpart E

3.3.1 Summary of Tests

FCC Section	ISED Section	Environmental Phenomena	Frequency Range (MHZ)	Result
15.203	N/A	Antenna requirements	Structural Requirement	Compliant
15.207	RSS-Gen	Conducted Disturbance at Mains Port	0.15 to 30	Compliant
15.407(c)	RSS-247 §6.2.2, §6.2.3	Bandwidth Requirement	6435 to 6515	Compliant
15.407(e)	RSS-247 §6.2.2, §6.2.3	Peak Output Power ¹	6435 to 6515	Compliant
15.407(f)	RSS-247 §6.2.2, §6.2.3	Antenna Conducted Spurious Emissions ¹	0.009 to 40000	N/A
15.407(g)	RSS-247 §6.2.2, §6.2.3	Radiated Spurious Emissions	0.009 to 40000	Compliant
15.407(h)	RSS-247 §6.2.2, §6.2.3	Peak Power Spectral Density ¹	6435 to 6515	Compliant
15.407(d)	RSS-247 §6.2.2, §6.2.3	Contention Based Protocol	6435 to 6515	Compliant

The testing was performed according to the procedures in ANSI C63.10-2013, KDB 789033, KDB 987594 and 47 CFR Part 15. Where applicable, KDB 662911 was followed to sum required measurements.

Note ¹: Various RU modes were considered for RF Power, PSD, and Spurious Emissions, and the "single client" RU mode is the worst case - the results herein are "single client" RU mode.

3.4 Results

In the configuration tested, the EUT complied with the requirements of the specification.

3.5 Test Location

Testing was performed at the Unified Compliance Laboratory 3-Meter and 10-Meter chambers located at 427 West 12800 South, Draper, UT 84020. Unified Compliance Laboratory is accredited by National Voluntary Laboratory Accreditation Program (NVLAP); NVLAP Code 600241-0 which is effective until 30 June 2024. This site has also been registered with Innovations, Science and Economic Development (ISED) department as was accepted under Appendix B, Phase 1 procedures of the APEC Tel MRA for Canadian recognition. ISED No.: 25346, effective until 30 June 2024.

Unified Compliance Laboratory has been assigned Designation Number US5037 by the FCC and Conformity Assessment Number US0223 by ISED.

4 Test Equipment

4.1 Conducted Emissions at Mains Ports

Type of Equipment	Manufacturer	Model Number	Asset Number	Date of Last Calibration	Due Date of Calibration
EMI Receiver	AFJ	FFT3010	UCL-6754	2/22/2023	2/22/2024
LISN	AFJ	LS16C/10	UCL-6749	12/6/2021	12/6/2023
ISN	Teseq	ISN T800	UCL-2974	6/27/2022	6/27/2024
LISN	Com-Power	LIN-120C	UCL-2612	1/24/2023	1/24/2024
AC Power Source	Laplace Instruments	AC1000A	UCL-2857	N/A	N/A
Test Software	UCL	Revision 1	UCL-3107	N/A	N/A

Table 1: List of equipment used for Conducted Emissions Testing at Mains Port

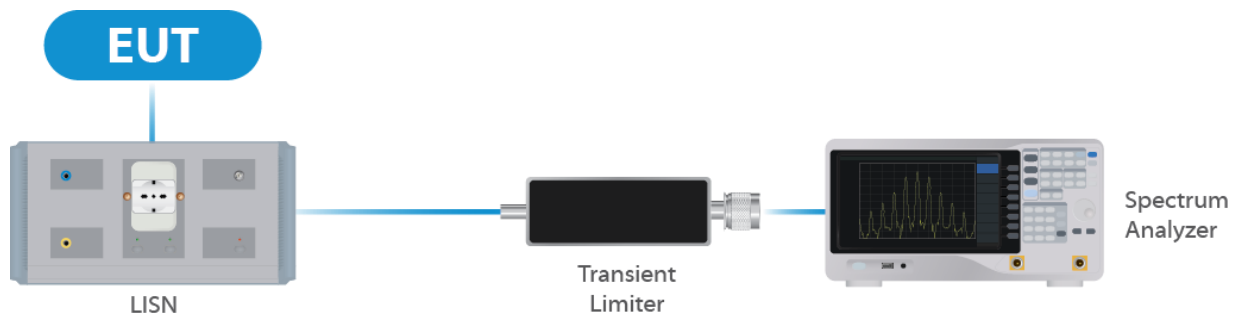

Figure 1: Conducted Emissions Test

4.2 Direct Connect at the Antenna Port Tests

Type of Equipment	Manufacturer	Model Number	Asset Number	Date of Last Calibration	Due Date of Calibration
Spectrum Analyzer	R&S	FSV40	UCL-2861	11/7/2022	11/7/2023
Signal Generator	R&S	SMB100A	UCL-2864	N/A	N/A
Vector Signal Generator	R&S	SMBV100A	UCL-2873	N/A	N/A
Switch Extension	R&S	OSP-B157WX	UCL-2867	2/22/2023	2/22/2024
Switch Extension	R&S	OSP-150W	UCL-2870	2/22/2023	2/22/2024

Table 2: List of equipment used for Direct Connect at the Antenna Port

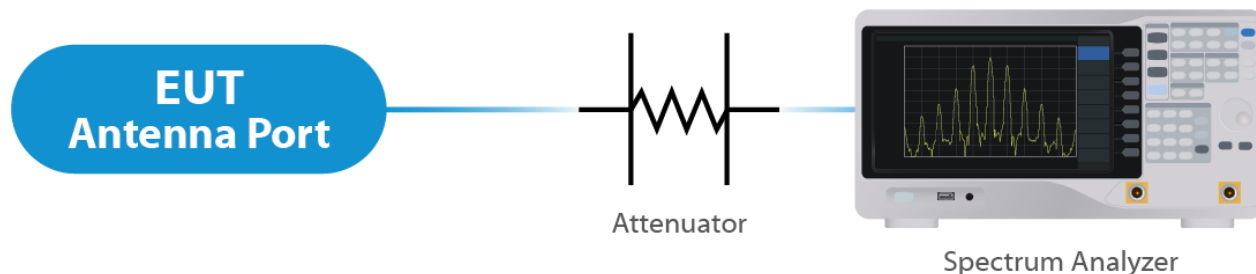

Figure 2: Direct Connect at the Antenna Port Test

4.3 Radiated Emissions

Type of Equipment	Manufacturer	Model Number	Asset Number	Date of Last Calibration	Due Date of Calibration
EMI Receiver	Keysight	N9038A	UCL-2778	1/27/2023	1/27/2024
Pre-Amplifier 9 kHz – 1 GHz	Sonoma Instruments	310N	UCL-2889	10/7/2021	10/7/2023
Broadband Antenna	Scwarzbeck	VULB 9163	UCL-3062	9/13/2022	9/13/2024
Broadband Antenna	Scwarzbeck	VULB 9163	UCL-3071	6/08/2022	6/22/2024
Double Ridge Horn Antenna	Scwarzbeck	BBHA 9120D	UCL-3065	9/22/2022	9/22/2024
Log Periodic	Scwarzbeck	STLP 9129	UCL-3068	1/27/2023	1/27/2025
15 - 40 GHz Horn Antenna	Scwarzbeck	BBHA 9170	UCL-2487	6/09/2022	6/09/2024
1 – 18 GHz Amplifier	Com-Power	PAM 118A	UCL-3833	12/9/2022	12/9/2023
Test Software	UCL	Revision 1	UCL-3108	N/A	N/A

Table 3: List of equipment used for Radiated Emissions

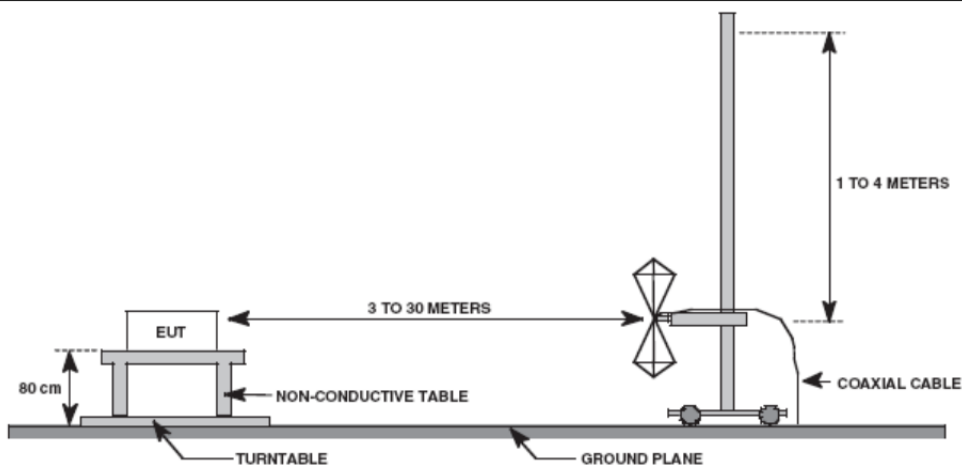

Figure 3a: Radiated Emissions Test 30-1000MHz

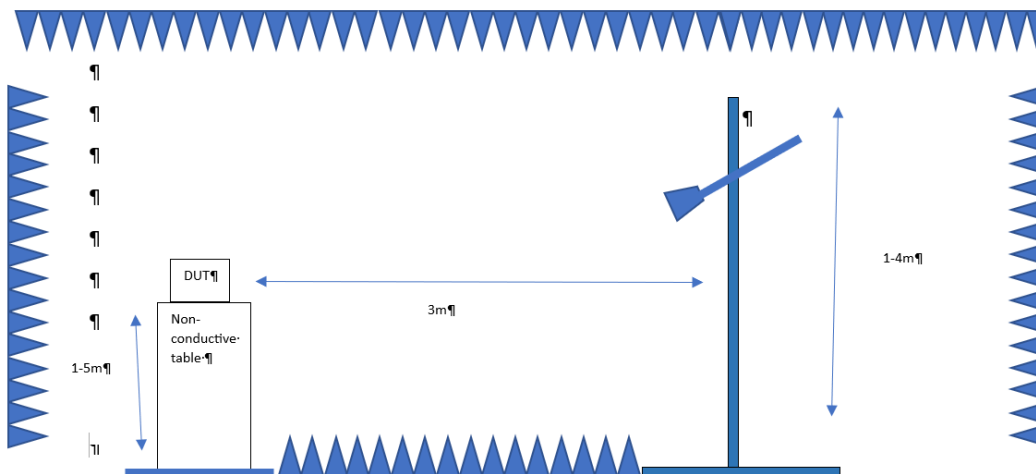

Figure 3b: Radiated Emissions Test Above 1GHz

4.4 Contention Base Protocol Tests

Type of Equipment	Manufacturer	Model Number	Asset Number	Date of Last Calibration	Due Date of Calibration
Spectrum Analyzer	Keysight	N9010B EXA	UCL-7069	4/25/2023	4/25/2024
Signal Generator	Keysight	MXG-B	UCL-6291	6/29/2023	6/29/2024
MIMO Test Set	Keysight	X8750A	UCL-7373	9/19/2023	9/19/2024

Table 4: List of equipment used for Direct Connect at the Antenna Port

Figure 1. CBP conducted test setup diagram. Source: KDB 987594 D02 V01r01

Figure 4: Contention Base Protocol Test

4.5 Equipment Calibration

All applicable equipment is calibrated using either an independent calibration laboratory or Unified Compliance Laboratory personnel at intervals defined in ANSI C63.4:2014 following outlined calibration procedures. All measurement instrumentation is traceable to the National Institute of Standards and Technology (NIST). Supporting documentation relative to traceability is on file and is available for examination upon request.

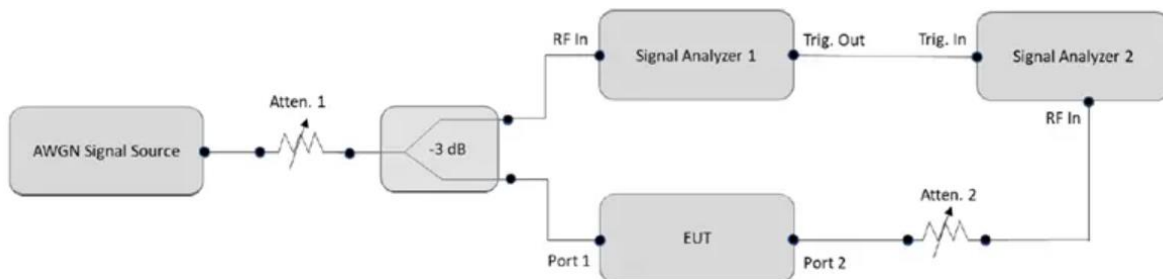
4.6 Measurement Uncertainty

Test	Uncertainty (\pm dB)	Confidence (%)
Conducted Emissions	1.44	95
Radiated Emissions (9 kHz to 30 MHz)	2.50	95
Radiated Emissions (30 MHz to 1 GHz)	4.38	95
Radiated Emissions (1 GHz to 18 GHz)	4.37	95
Radiated Emissions (18 GHz to 40 GHz)	3.93	95
Direct Connect Tests	K Factor	Value
Emissions Bandwidth	2	2.0%
Output Power	2	1.0 dB
Peak Power Spectral Density	2	1.3 dB
Band Edge	2	0.8 dB
Transmitter Spurious Emissions	2	1.8 dB

5 Test Results

5.1 §15.203 Antenna Requirements

The EUT uses an integral antenna. Per the manufacturer, the Maximum gain of the antenna per chain is 5.8 dBi. This is an 802.11 device and utilizes CDD as described in KDB 662911 D01. The antenna is not user replaceable. For CDD transmissions, directional gain is calculated as follows.

$$\text{Array Gain} = 10 \log(\text{NANT}/\text{NSS}) \text{ dB}$$

NANT = number of transmit antennas and

NSS = number of spatial streams. NSS = 1 considered worst case.

For power measurements on IEEE 802.11 devices, Array Gain = 0 dB for $\text{NANT} \leq 4$;

For PSD measurements when $\text{Nss}=1$: Array Gain = $10 \log(\text{NANT}/\text{NSS})$ (dB) + Antenna Gain (dBi). Or $3.01 \text{ dB} + 5.8 \text{ dBi} = 8.81 \text{ dBi}$

Results

The EUT complied with the specification

5.2 Conducted Emissions at Mains Ports Data

5.2.1 Line

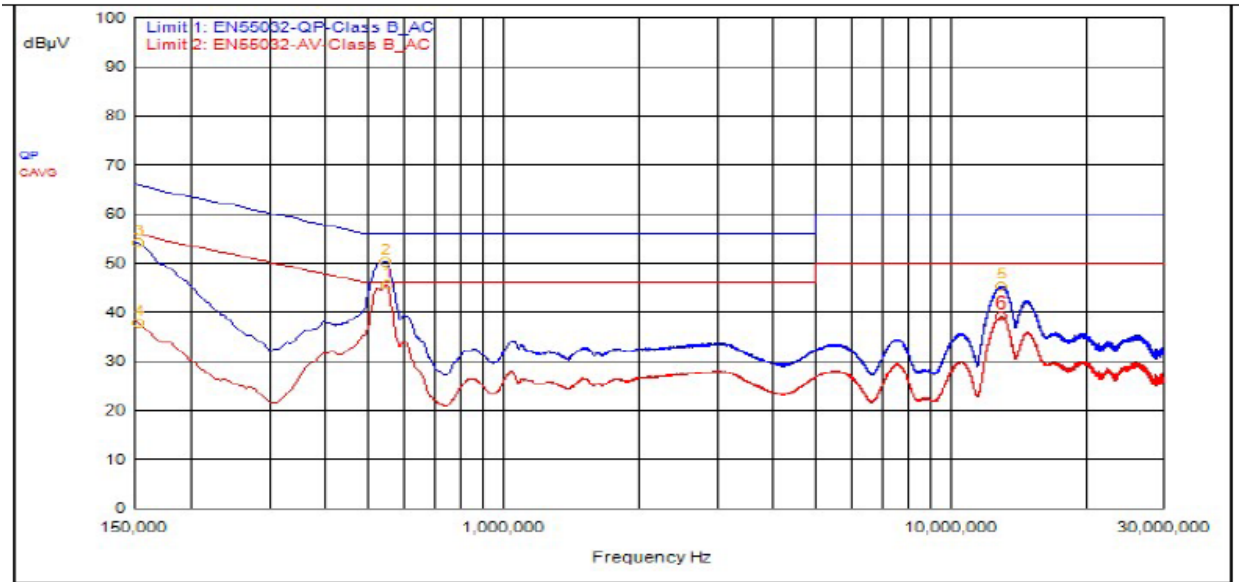

ID	Frequency	Probe	Cable	Atten.	Detector	Meter Read	Meas Level	Limit 1	Limit 1 Dist.	Limit 2	Limit 2 Dist.	P/F
MU	MHz	dB	dB	dB	Type	dBµV	dBµV	dBµV	dB	dBµV	dB	P/F
2	546,000kHz	12.23	0.00		QPeak	38.16	50.39	56.00	-5.61			
3	153,000kHz	12.26	0.00		QPeak	41.82	54.08	65.84	-11.76			
5	12.996	12.27	0.00		QPeak	33.02	45.29	60.00	-14.71			
1	549,000kHz	12.23	0.00		C_AVG	33.22	45.45			46.00	-0.55	
4	153,000kHz	12.26	0.00		C_AVG	25.61	37.87			55.84	-17.96	
6	12.981	12.27	0.00		C_AVG	26.77	39.04			50.00	-10.96	

5.2.2 Neutral

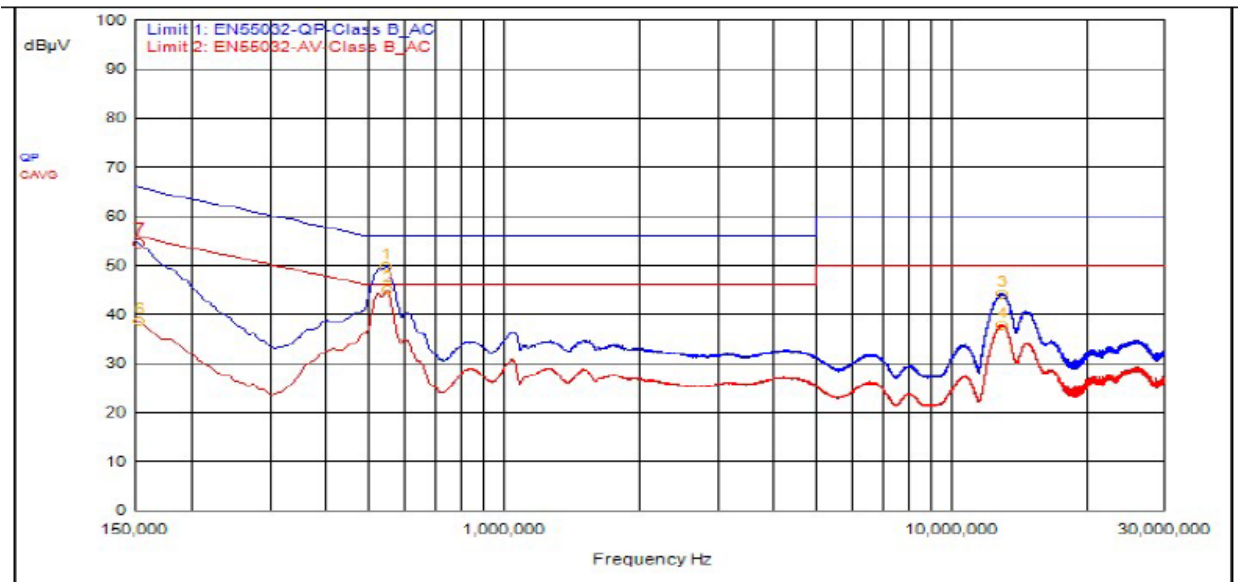

ID	Frequency	Probe	Cable	Atten.	Detector	Meter Read	Meas Level	Limit 1	Limit 1 Dist.	Limit 2	Limit 2 Dist.	P/F
MU	MHz	dB	dB	dB	Type	dBµV	dBµV	dBµV	dB	dBµV	dB	P/F
1	546,000kHz	12.18	0.00		QPeak	37.58	49.76	56.00	-6.24			
5	150,000kHz	12.21	0.00		QPeak	42.89	55.10	66.00	-10.90			
7	153,000kHz	12.21	0.00		QPeak	42.12	54.33	65.84	-11.50			
3	12.993	12.29	0.00		QPeak	31.97	44.26	60.00	-15.74			
2	549,000kHz	12.18	0.00		C_AVG	32.76	44.94			46.00	-1.06	
4	12.966	12.29	0.00		C_AVG	25.48	37.77			50.00	-12.23	
6	153,000kHz	12.21	0.00		C_AVG	26.39	38.60			55.84	-17.24	

Result

The EUT complied with the specification limit.

5.3 §15.403(i) 26 dB Emissions Bandwidth

All chains were measured under the guidance of KDB 789033 Section II.C. and KDB 66291 D01. Please see associated annex for details on instrument settings.

Nominal BW (MHz)	Frequency (MHz)	99% Bandwidth (MHz)	26 dB Bandwidth (MHz)
20	6435	19.1	22.2
20	6475	19.1	23.3
20	6515	19.1	22.5
40	6445	38.3	43.2
40	6485	38.3	42.6
80	6465	77.5	86.5
160	6505	157.0	175.0

Result

All chains were tested and the highest bandwidth per chain is reported above.

The 26 dB bandwidths are reported for information purposes. Please see Annex for all bandwidth measurements.

5.4 §15.407(a)(3) Maximum Average Output Power

All chains were measured and summed under the guidance of KDB 789033 Section II. E.2. and KDB 66291 D01. Please see associated annex for details on instrument settings.

The maximum average RF conducted output power measured for this device was 21.8 dBm or 151.36 mW. The limit is 30 dBm EIRP, or 1 Watt EIRP. The antenna has a gain of 5.8 dBi.

Modulation (BW)	Frequency (MHz)	Data Rate	TP Setting	Conducted Output Power	EIRP	Measured PSD
EHT20	6435	Mcs0_Nss2	10	12.63	18.43	-1.58
EHT20	6475	Mcs0_Nss2	10	12.79	18.59	-1.34
EHT20	6515	Mcs0_Nss2	10	12.85	18.65	-1.27
EHT40	6445	Mcs0_Nss2	13	15.55	21.35	-1.61
EHT40	6485	Mcs0_Nss2	13	15.72	21.52	-1.49
EHT80	6465	Mcs0_Nss2	16	18.79	24.59	-1.34
EHT160	6505	Mcs0_Nss2	19	21.80	27.60	-1.05

Modulation (BW)	Frequency (MHz)	Data Rate	TP Setting	Conducted Output Power	EIRP	Measured PSD
EHT20	6435	Mcs0_Nss1	7	9.57	15.37	-4.54
EHT20	6475	Mcs0_Nss1	7	9.67	15.47	-4.57
EHT20	6515	Mcs0_Nss1	7	9.83	15.63	-4.31
EHT40	6445	Mcs0_Nss1	1	13.41	19.21	-3.88
EHT40	6485	Mcs0_Nss1	1	13.59	19.39	-3.67
EHT80	6465	Mcs0_Nss1	13	15.73	21.53	-4.48
EHT160	6505	Mcs0_Nss1	16	19.05	24.85	-3.90

Result

In the configuration tested, the maximum average RF outpower was less than 1 watt EIRP; therefore, the EUT complied with the requirements of the specification (see spectrum analyzer plots in attached Annex).

5.5 §15.407(b)(7) Spurious Emissions

5.5.1 Conducted Spurious Emissions

The frequency range from the lowest frequency generated or used in the device to the tenth harmonic of the highest fundamental frequency was investigated to measure any antenna-conducted emissions. The graphs show the measurement data from spurious emissions noted across the frequency range when transmitting at the lowest frequency, middle frequency and upper frequency. Shown below are plots with the EUT turned to the upper and lower channels with the antenna gain of 5.8 dBi accounted for. These demonstrate compliance with the provisions of this section at the band edges.

The emissions must be remain below -27 dBm EIRP.

Result

Conducted spurious emissions were attenuated below the limit; therefore, the EUT complies with the specification.

5.5.2 Radiated Spurious Emissions in the Restricted Bands of § 15.205

The EUT uses various power settings based on the channel in use. In order to reduce test time, the radiated spurious emissions at the lowest, middle, and highest channel were measured at the maximum power of TP19.

Correction Factor = Antenna Factor + Cable Loss - Pre-Amplifier Gain, and is added to the Receiver reading.

Result

All emissions in the restricted bands of § 15.205 met the limits specified in § 15.209; therefore, the EUT complies with the specification. See Annex for Conducted Band edge plots.

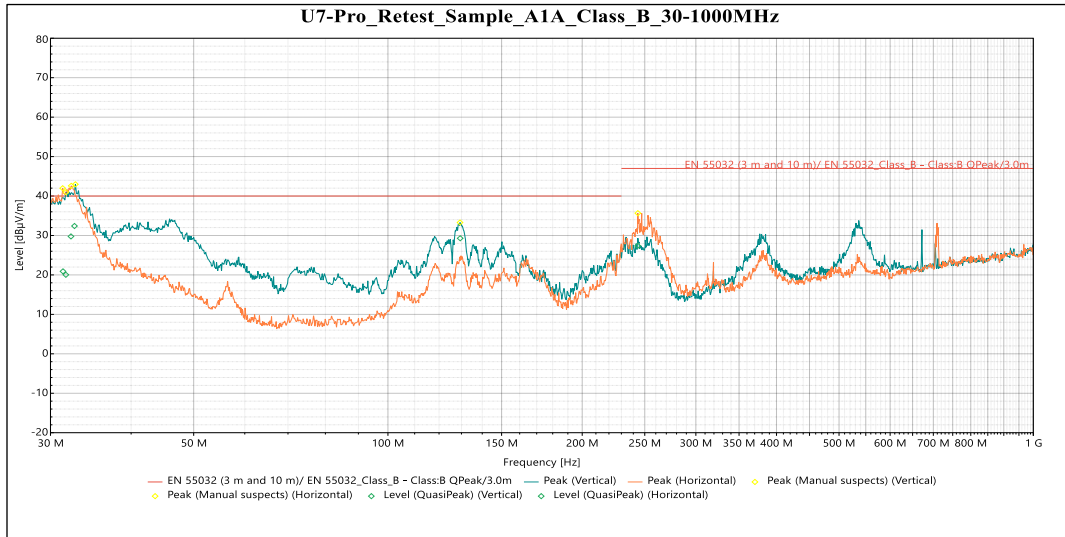

QuasiPeak

Frequency	Level (dBµV/m)	Limit (dBµV/m)	Margin	Azimuth (°)	Height	Pol.	Correction (dB)
31.692 MHz	20.029	40	-19.971	69	2.759	Vertical	-8.569
32.681 MHz	32.403	40	-7.597	199	1	Vertical	-9.148
129.41 MHz	29.287	40	-10.713	341	1.138	Vertical	-14.232
31.369 MHz	20.912	40	-19.088	251	1.143	Horizontal	-8.51
32.273 MHz	29.759	40	-10.241	50	3.298	Horizontal	-8.831
243.82 MHz	27.376	47	-19.624	278	1.52	Horizontal	-15.915

Table 5: Radiated Emissions 30 – 1000 MHz

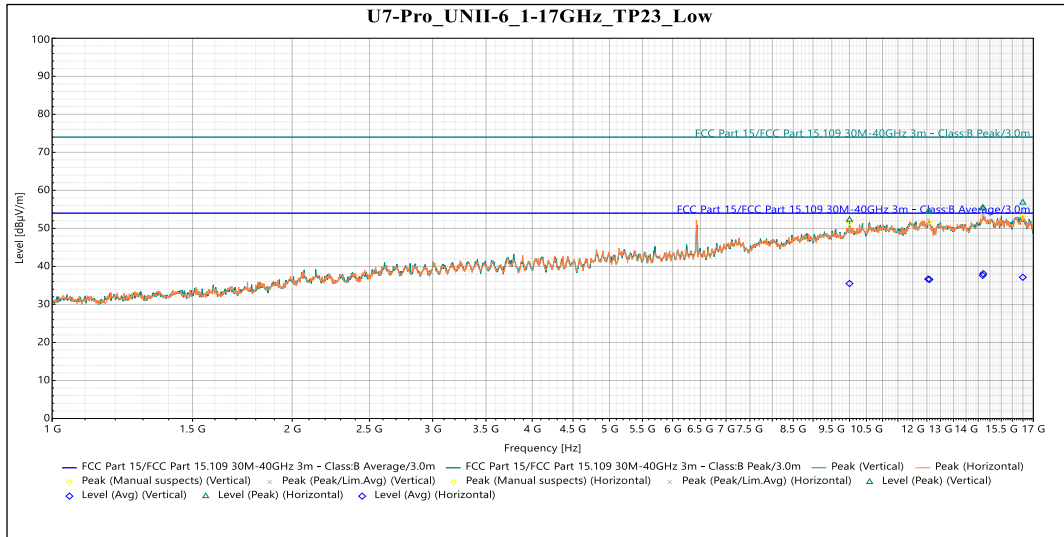

Peak

Frequency	Level (dBµV/m)	Limit (dBµV/m)	Margin (dB)	Azimuth (°)	Height (m)	Pol.	Correction (dB)
9.9989 GHz	52.275	74	-21.725	230	1.847	Vertical	14.138
12.547 GHz	54.32	74	-19.68	122	1.82	Vertical	16.621
14.714 GHz	55.279	74	-18.721	247	2.729	Vertical	17.301
12.597 GHz	54.463	74	-19.537	126	1.638	Horizontal	16.766
14.69 GHz	55.403	74	-18.597	58	3.798	Horizontal	17.336
16.491 GHz	56.789	74	-17.211	228	3.448	Horizontal	18.271

Avg

Frequency	Level (dBµV/m)	Limit (dBµV/m)	Margin (dB)	Azimuth (°)	Height (m)	Pol.	Correction (dB)
9.9989 GHz	35.491	54	-18.509	230	1.847	Vertical	14.138
12.547 GHz	36.665	54	-17.335	122	1.82	Vertical	16.621
14.714 GHz	38.09	54	-15.91	247	2.729	Vertical	17.301
12.597 GHz	36.564	54	-17.436	126	1.638	Horizontal	16.766
14.69 GHz	37.625	54	-16.375	58	3.798	Horizontal	17.336
16.491 GHz	37.142	54	-16.858	228	3.448	Horizontal	18.271

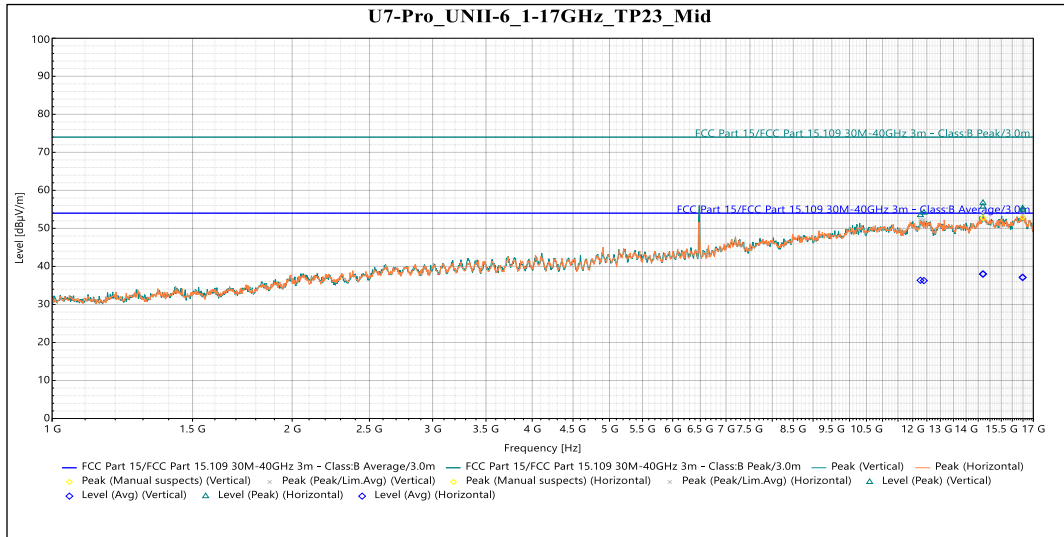
Table 6: Radiated Emissions 1 – 17 GHz Lowest Frequency



Peak

Frequency	Level (dBµV/m)	Limit (dBµV/m)	Margin (dB)	Azimuth (°)	Height (m)	Pol.	Correction (dB)
12.271 GHz	53.49	74	-20.51	25	3.1	Vertical	16.49
14.7 GHz	56.71	74	-17.29	129	3.444	Vertical	17.463
16.484 GHz	55.259	74	-18.741	257	3.448	Vertical	18.265
12.394 GHz	54.139	74	-19.861	331	1.872	Horizontal	16.328
14.701 GHz	55.711	74	-18.289	81	1.643	Horizontal	17.451
16.484 GHz	54.836	74	-19.164	113	1.643	Horizontal	18.265

Avg

Frequency	Level (dBµV/m)	Limit (dBµV/m)	Margin (dB)	Azimuth (°)	Height (m)	Pol.	Correction (dB)
12.271 GHz	36.346	54	-17.654	25	3.1	Vertical	16.49
14.7 GHz	37.953	54	-16.047	129	3.444	Vertical	17.463
16.484 GHz	37.076	54	-16.924	257	3.448	Vertical	18.265
12.394 GHz	36.271	54	-17.729	331	1.872	Horizontal	16.328
14.701 GHz	38.053	54	-15.947	81	1.643	Horizontal	17.451
16.484 GHz	37.143	54	-16.857	113	1.643	Horizontal	18.265

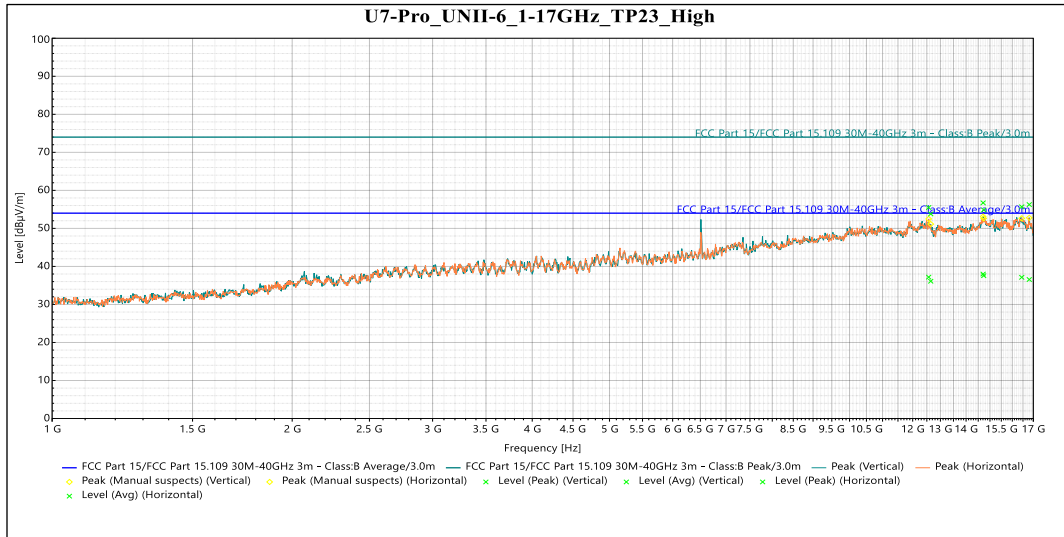
Table 7: Radiated Emissions 1 – 17 GHz Middle Frequency



Peak

Frequency	Level (dBµV/m)	Limit (dBµV/m)	Margin (dB)	Azimuth (°)	Height (m)	Pol.	Correction (dB)
12.642 GHz	53.797	74	-20.203	9	2.721	Vertical	16.073
14.707 GHz	56.725	74	-17.275	1	2.539	Vertical	17.382
16.803 GHz	56.259	74	-17.741	5	3.621	Vertical	18.752
12.567 GHz	55.487	74	-18.513	354	2.747	Horizontal	16.679
14.731 GHz	54.853	74	-19.147	335	3.977	Horizontal	17.187
16.441 GHz	55.669	74	-18.331	117	3.277	Horizontal	18.226

Avg

Frequency	Level (dBµV/m)	Limit (dBµV/m)	Margin (dB)	Azimuth (°)	Height (m)	Pol.	Correction (dB)
12.642 GHz	36.095	54	-17.905	9	2.721	Vertical	16.073
14.707 GHz	37.988	54	-16.012	1	2.539	Vertical	17.382
16.803 GHz	36.55	54	-17.45	5	3.621	Vertical	18.752
12.567 GHz	37.179	54	-16.821	354	2.747	Horizontal	16.679
14.731 GHz	37.549	54	-16.451	335	3.977	Horizontal	17.187
16.441 GHz	37.129	54	-16.871	117	3.277	Horizontal	18.226

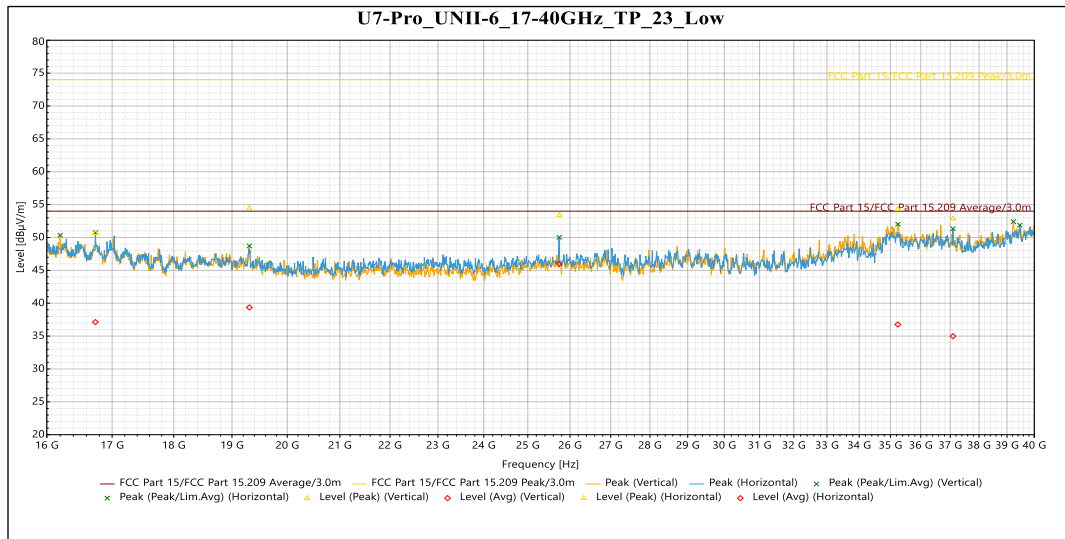
Table 8: Radiated Emissions 1 – 17 GHz Highest Frequency

Peak

Frequency	Level (dBµV/m)	Limit (dBµV/m)	Margin (dB)	Azimuth (°)	Pol.	Correction (dB)
19.309 GHz	54.489	74	-19.511	59	Vertical	-0.74
35.244 GHz	54.306	74	-19.694	268	Vertical	5.927
16.739 GHz	50.663	74	-23.337	7	Horizontal	0.866
25.74 GHz	53.398	74	-20.602	273	Horizontal	-1.634
37.092 GHz	52.862	74	-21.138	231	Horizontal	4.16

Avg

Frequency	Level (dBµV/m)	Limit (dBµV/m)	Margin (dB)	Azimuth (°)	Pol.	Correction (dB)
19.309 GHz	39.36	54	-14.64	59	Vertical	-0.74
35.244 GHz	36.763	54	-17.237	268	Vertical	5.927
16.739 GHz	37.129	54	-16.871	7	Horizontal	0.866
25.74 GHz	45.969	54	-8.031	273	Horizontal	-1.634
37.092 GHz	34.984	54	-19.016	231	Horizontal	4.16

Table 9: Radiated Emissions 17 – 40 GHz Lowest Frequency (worse case)

5.6 §15.407(a) Maximum Power Spectral Density

All chains were measured and summed under the guidance of KDB 789033 Section II. F. and KDB 66291 D01. Please see associated annex for details on instrument settings.

The maximum average power spectral density conducted from the intentional radiator of the antenna shall not be greater than 5 dBm EIRP in any 1 MHz band during any time interval of continuous transmission. As per KDB 662911, When the EUT is using spatial-multiplexing in HE modes, there is not additional array gain to accommodate. When the EUT uses Nss=1 data rates, the antenna gain is 5.8 dBi + Array gain of 3.01 dB which is a total of 8.81 dBi.

Results of this testing are summarized.

Modulation (BW)	Frequency (MHz)	Data Rate	TP Setting	Conducted Output Power	Measured PSD
EHT20	6435	Mcs0_Nss2	10	12.63	-1.58
EHT20	6475	Mcs0_Nss2	10	12.79	-1.34
EHT20	6515	Mcs0_Nss2	10	12.85	-1.27
EHT40	6445	Mcs0_Nss2	13	15.55	-1.61
EHT40	6485	Mcs0_Nss2	13	15.72	-1.49
EHT80	6465	Mcs0_Nss2	16	18.79	-1.34
EHT160	6505	Mcs0_Nss2	19	21.80	-1.05

Modulation (BW)	Frequency (MHz)	Data Rate	TP Setting	Conducted Output Power	Measured PSD
EHT20	6435	Mcs0_Nss1	7	9.57	-4.54
EHT20	6475	Mcs0_Nss1	7	9.67	-4.57
EHT20	6515	Mcs0_Nss1	7	9.83	-4.31
EHT40	6445	Mcs0_Nss1	11	13.41	-3.88
EHT40	6485	Mcs0_Nss1	11	13.59	-3.67
EHT80	6465	Mcs0_Nss1	13	15.73	-4.48
EHT160	6505	Mcs0_Nss1	16	19.05	-3.90

Result

The maximum average power spectral density was less than the limit of 5 dBm EIRP; therefore, the EUT complies with the specification.

5.6.1 OFDMA RU Check

If EUT supports OFDMA multiple partial Resource Unit (RU) configurations were verified and the worst case mode was tested.

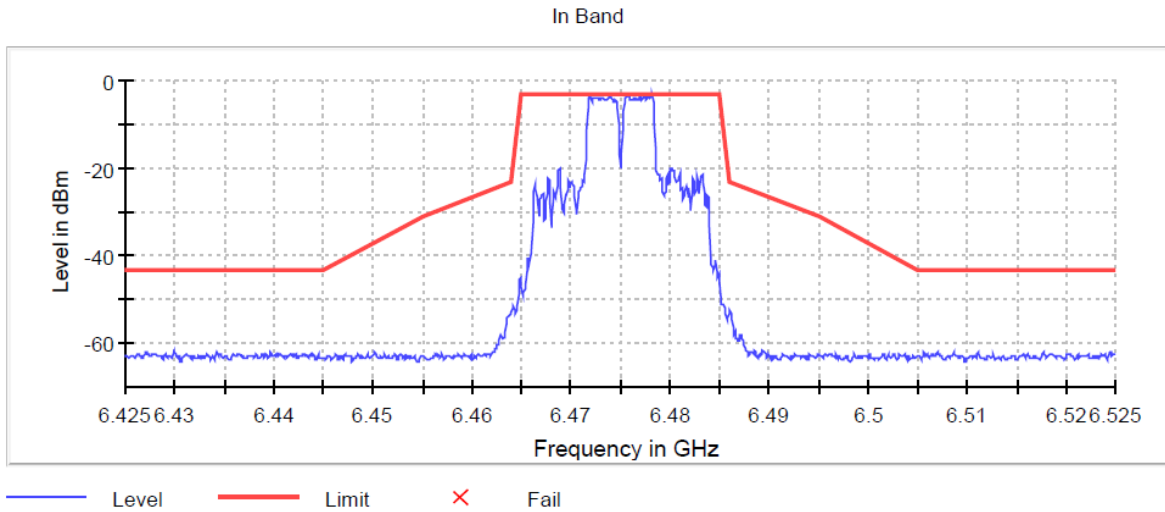

Figure 5: 6475 20MHz RU Vérification - Center

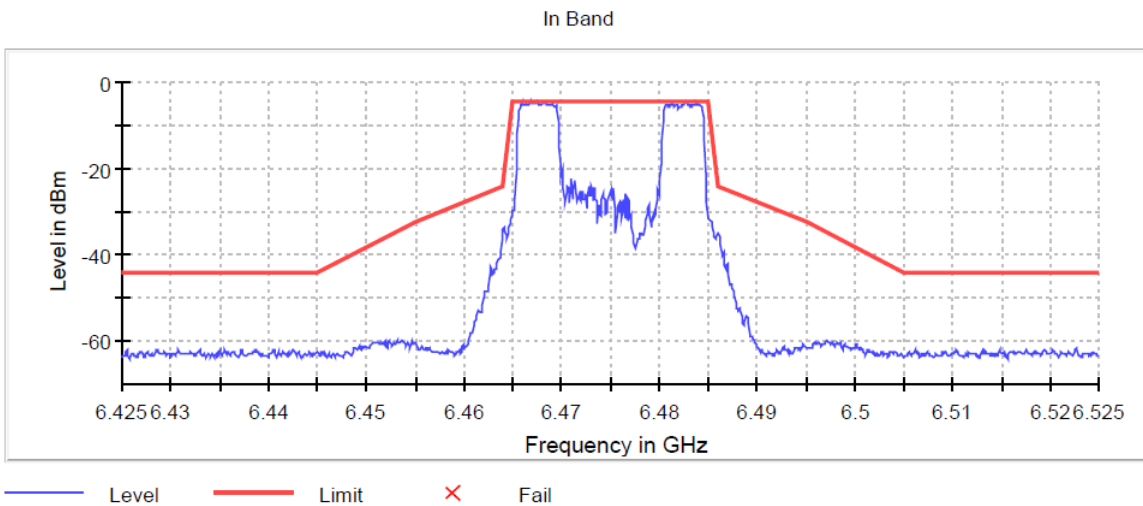

Figure 6: 6475 20MHz RU Vérification - Edge

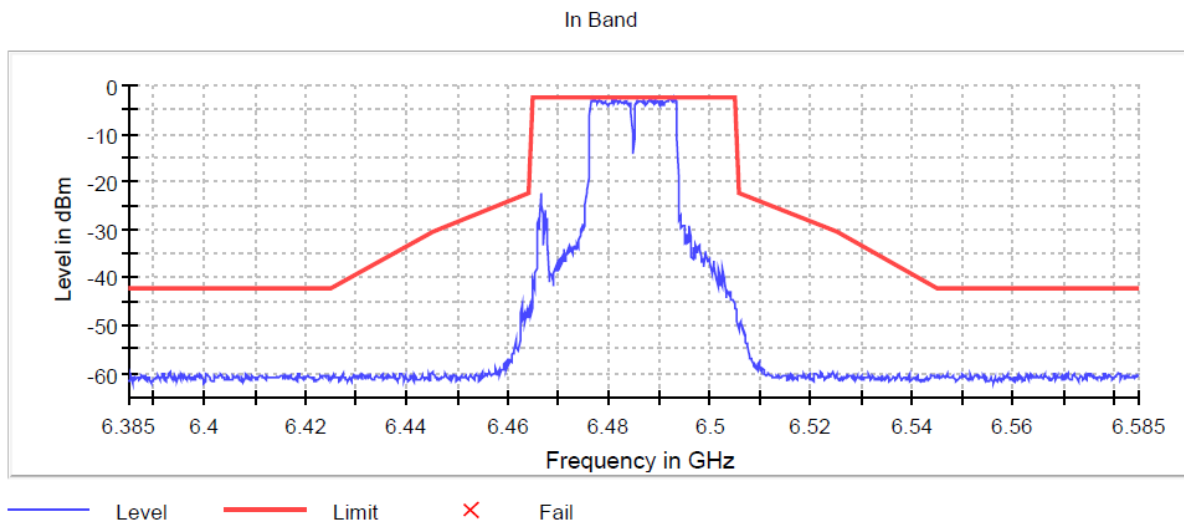

Figure 7: 6485 40MHz RU Vérification - Center

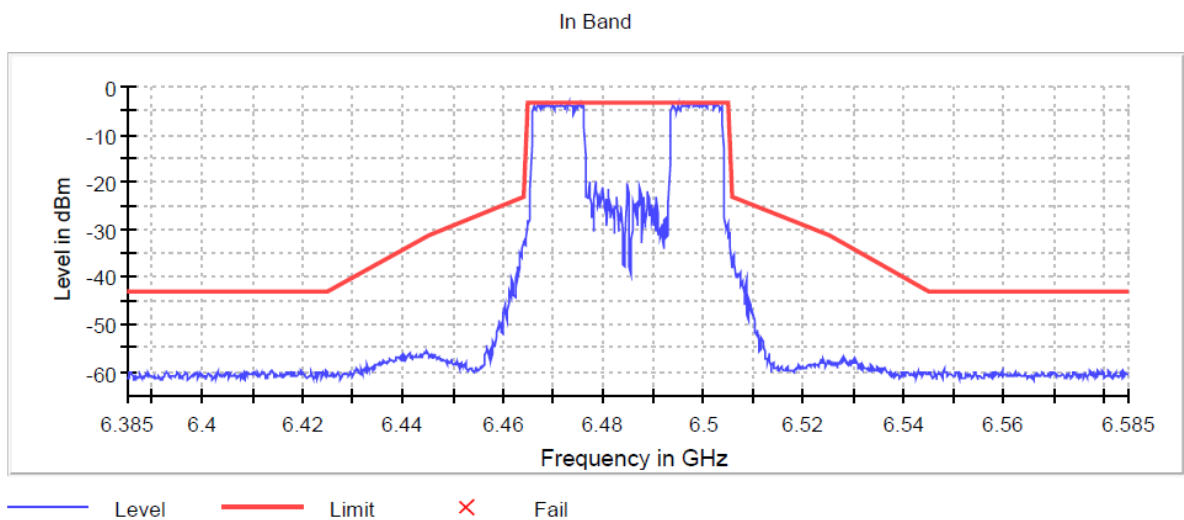

Figure 8: 6485 40MHz RU Vérification - Edge

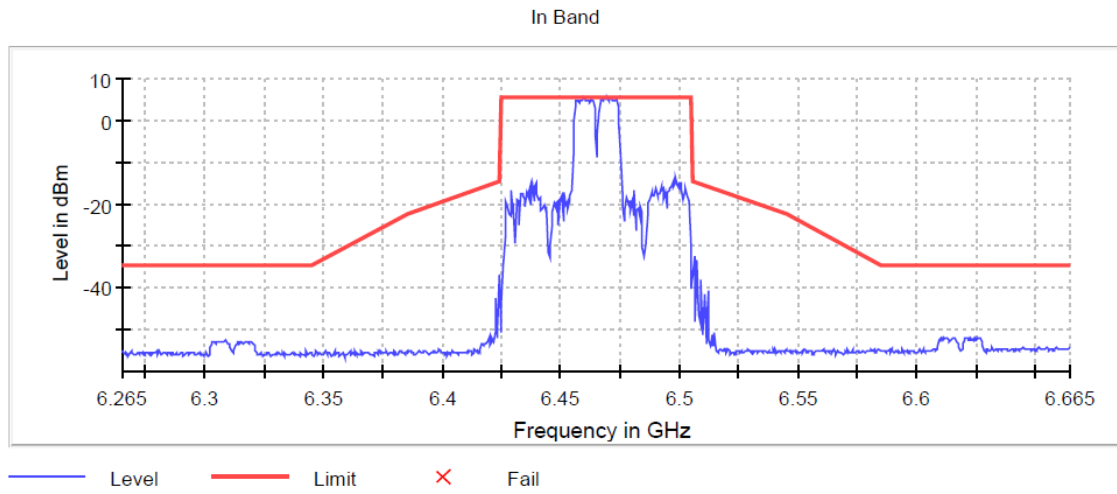

Figure 9: 6465 80MHz RU Vérification - Center

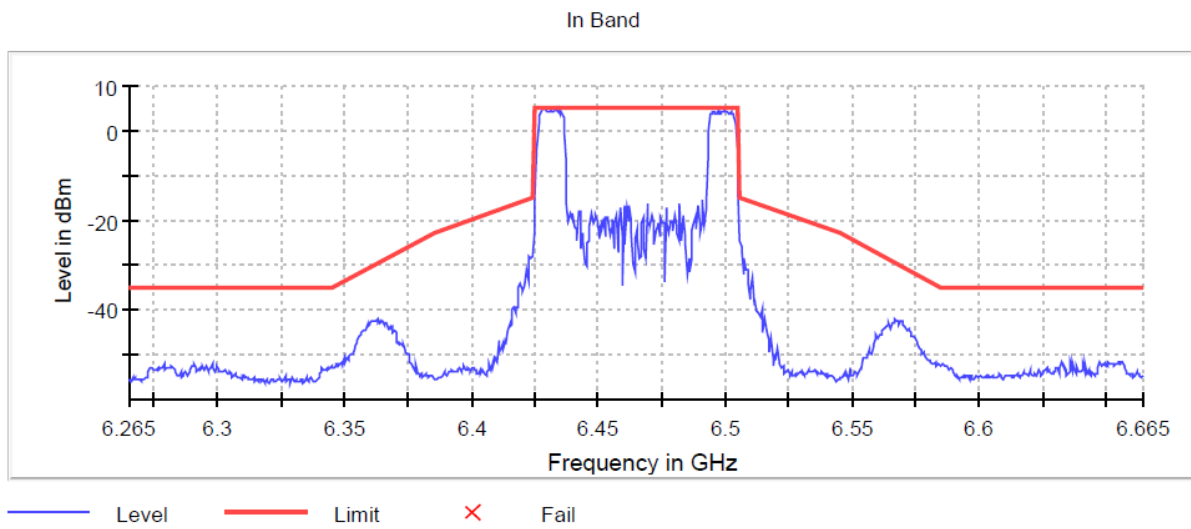

Figure 10: 6465 80MHz RU Vérification - Edge

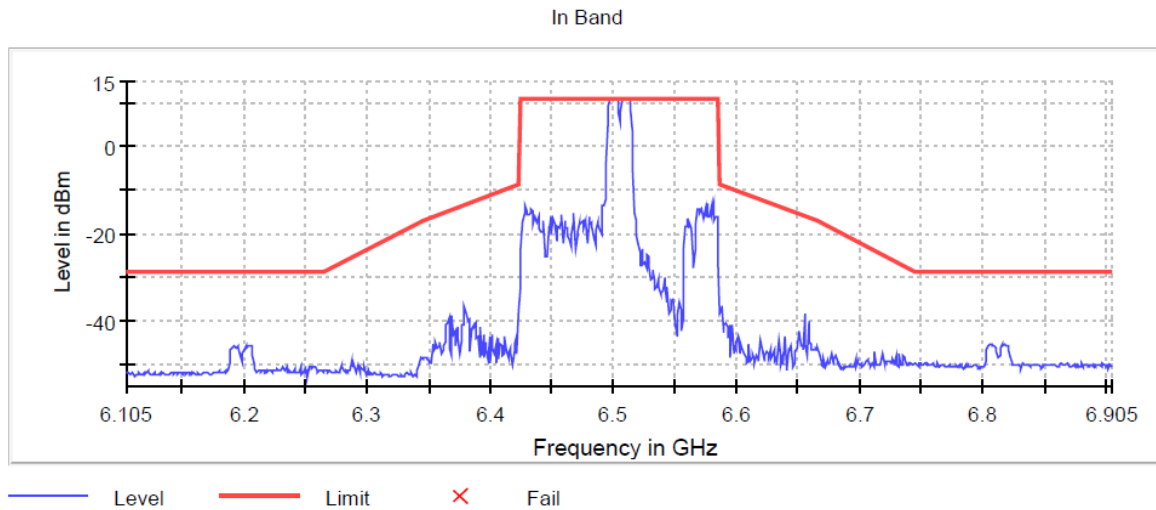

Figure 11: 6505 160MHz RU Vérification - Center

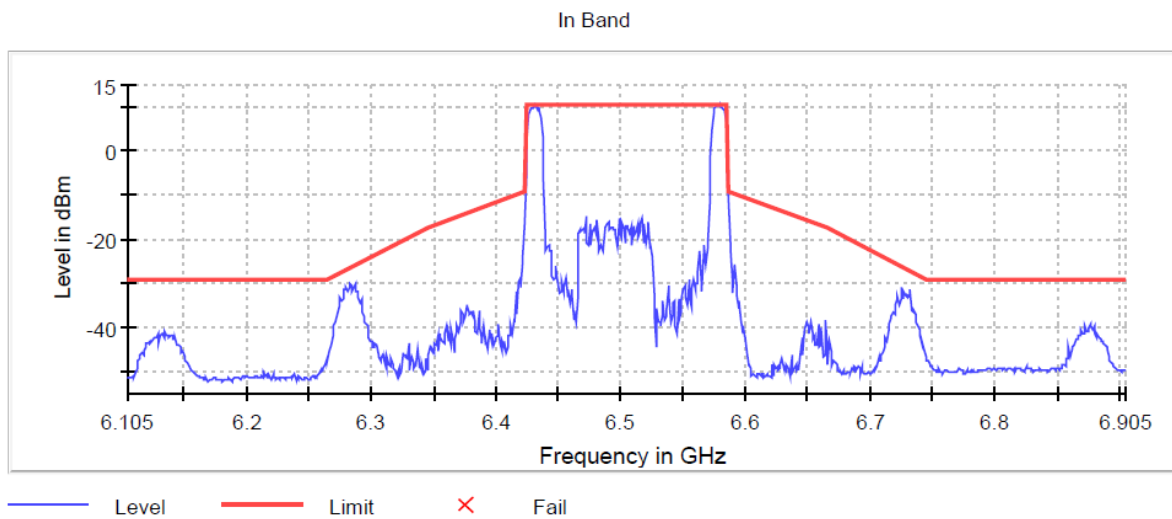

Figure 12: 6505 160MHz RU Vérification - Edge

5.7 §15.407(d) Contention Based Protocol

This product was tested and found to be compliant with the requirements of Contention-based Protocol as specified in FCC Part 15.407 and KDB 987594 D02.

Initially the test setup was connected directly to the signal source with all splitters (splitters terminated with a 50-ohm loads on unused ports) and cables in place to verify the AWGN signal is 10MHz wide at a signal level of less than or equal to -82dBm and for conducted measurements the threshold was adjusted for an antenna gain for 0dBi. The level at the signal generator required to achieve the required signal level at the DUT was recorded for use during testing.

The DUT was connected as shown in figure 4 above and set to transmit at a constant duty cycle at each frequency and bandwidth noted in the table below and verified to be communicating with the companion device as intended.

Starting at the levels established above, the AWGN signal was introduced to the DUT and increased to determine a threshold level at where the DUT will terminate with at least a 90% detection rate. The level at the DUT, which the 90% detection rate was achieved was recorded as the “Sensitivity Level” below.

Testing shall be repeated at each applicable channel and bandwidth as noted in Table 1 of KDB 987594 D02.

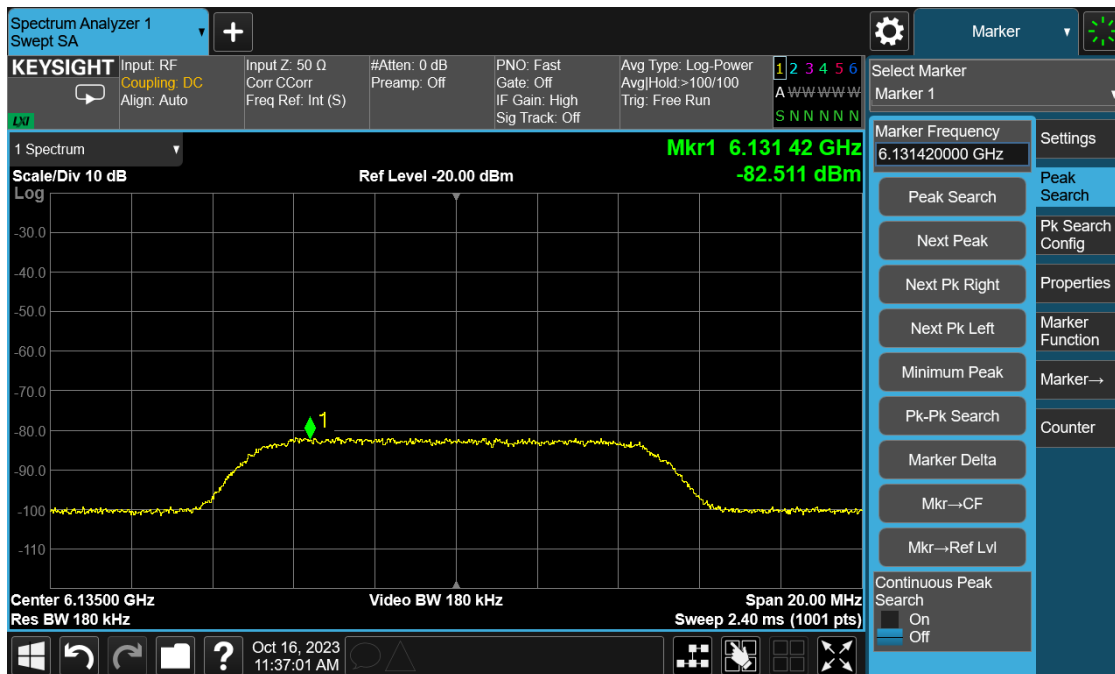

Plot 1: Level Details

Band	BW _{EUT}	F _{c1}	F _{c2}	Signal Power Level (dBm)	Detection Rate (%)	Margin (dB)
UNII-5 5.925 - 6.425GHz	20	6135	6135	-73	100	16.8
			6110	-76	100	19.8
	160	6185	6185	-75	100	18.8
			6260	-76	100	19.8
UNII-6 6.425 - 6.525GHz	20	6455	6455	-73	100	16.8
			6430	-76	100	19.8
	160	6505	6505	-72	100	15.8
			6580	-72	100	15.8
UN1-7 6.525 - 6.875GHz	20	6695	6695	-72	100	15.8
			6590	-68	100	11.8
	160	6665	6665	-62	100	5.8
			6740	-72	100	15.8
UNII-8 6.875 - 7.125GHz	20	7015	7015	-76	100	19.8
			6910	-70	100	13.8
	160	6985	6985	-70	100	13.8
			7060	-73	100	16.8

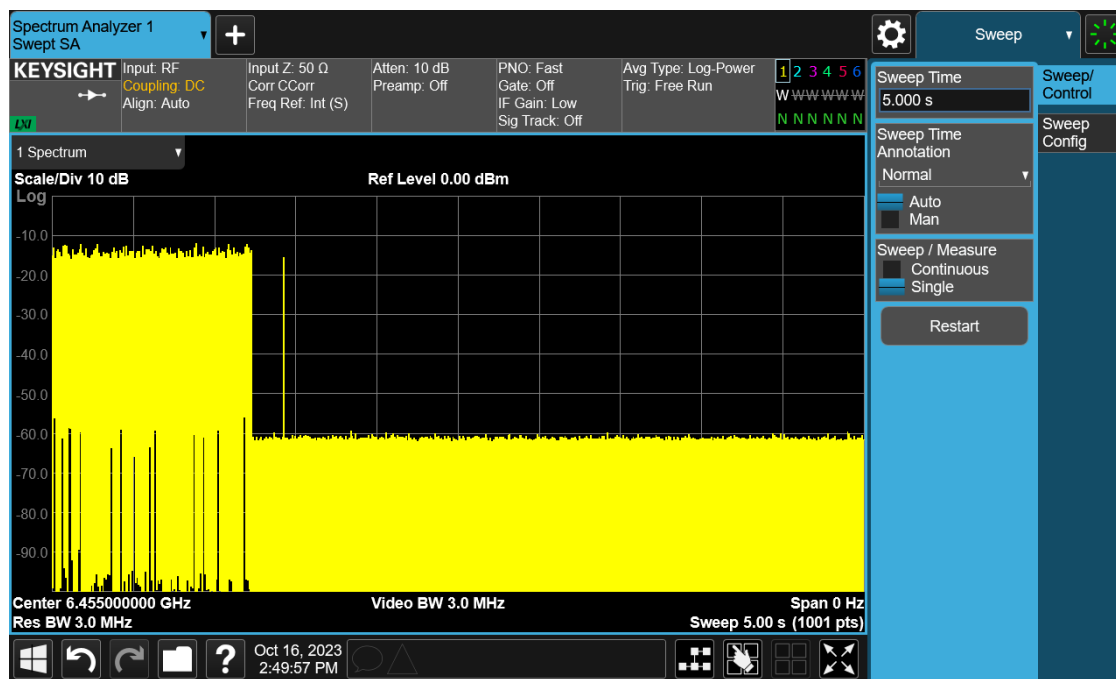
Table 10: Trial Table

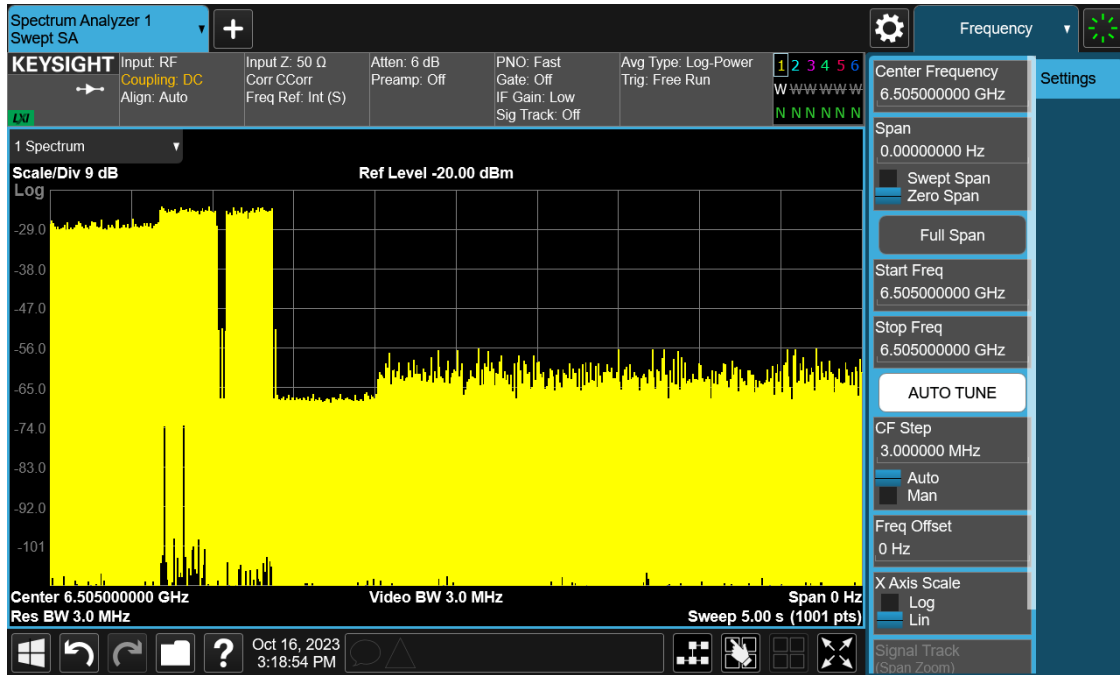
Plot 2: 20MHz Example Detection Trace



Plot 3: 160MHz Example Detection Trace

Result

The EUT complies with the specification.

-- End of Test Report --