

# FCC SAR Test Report

APPLICANT : ZTE CORPORATION  
EQUIPMENT : LTE/WCDMA Tablet  
BRAND NAME : ZTE  
MODEL NAME : K92  
FCC ID : SRQ-K92  
STANDARD : FCC 47 CFR Part 2 (2.1093)  
ANSI/IEEE C95.1-1992  
IEEE 1528-2013

We, Sporton International (KunShan) INC., would like to declare that the tested sample has been evaluated in accordance with the procedures and had been in compliance with the applicable technical standards.

The test results in this report apply exclusively to the tested model / sample. Without written approval of Sporton International (KunShan) INC., the test report shall not be reproduced except in full.



Prepared by: Mark Qu / Manager



Approved by: Jones Tsai / Manager



**Sporton International (KunShan) INC.**  
**No.3-2, Pingxiang Road, Kunshan Development Zone, Jiangsu, China**



**Table of Contents**

**1. Statement of Compliance ..... 4**

**2. Administration Data ..... 5**

**3. Guidance Applied..... 5**

**4. Equipment Under Test (EUT) Information..... 6**

    4.1 General Information ..... 6

    4.2 General LTE SAR Test and Reporting Considerations ..... 7

**5. Proximity Sensor Triggering Test.....10**

**6. RF Exposure Limits.....14**

    6.1 Uncontrolled Environment .....14

    6.2 Controlled Environment.....14

**7. Specific Absorption Rate (SAR).....15**

    7.1 Introduction .....15

    7.2 SAR Definition.....15

**8. System Description and Setup .....16**

    8.1 E-Field Probe .....17

    8.2 Data Acquisition Electronics (DAE) .....17

    8.3 Phantom.....17

    8.4 Device Holder.....18

**9. Measurement Procedures .....19**

    9.1 Spatial Peak SAR Evaluation .....19

    9.2 Power Reference Measurement.....20

    9.3 Area Scan .....20

    9.4 Zoom Scan.....21

    9.5 Volume Scan Procedures .....21

    9.6 Power Drift Monitoring.....21

**10. Test Equipment List.....22**

**11. System Verification .....23**

    11.1 Tissue Simulating Liquids .....23

    11.2 Tissue Verification .....24

    11.3 System Performance Check Results .....25

**12. RF Exposure Positions .....26**

    12.1 SAR Testing for Tablet .....26

**13. Conducted RF Output Power (Unit: dBm).....27**

**14. Antenna Location .....64**

**15. SAR Test Results .....67**

    15.1 Body SAR .....69

    15.2 Repeated SAR Measurement .....74

**16. Simultaneous Transmission Analysis .....75**

    16.1 Body Exposure Conditions .....76

    16.2 SPLSR Evaluation and Analysis.....85

**17. Uncertainty Assessment .....90**

**18. References.....93**

**Appendix A. Plots of System Performance Check**

**Appendix B. Plots of High SAR Measurement**

**Appendix C. DASYS Calibration Certificate**

**Appendix D. Test Setup Photos**





**1. Statement of Compliance**

The maximum results of Specific Absorption Rate (SAR) found during testing for **ZTE CORPORATION, LTE/WCDMA Tablet, K92** are as follows.

Equipment Class	Frequency Band		Highest SAR Summary	
			Body	
			1g SAR (W/kg)	
Licensed	WCDMA	Band V	1.14	1.59
		Band IV	1.17	
		Band II	1.17	
	LTE	Band 12	1.15	
		Band 5	<b>1.20</b>	
		Band 4	1.20	
		Band 2	1.19	
		Band 30	1.20	
		Band 7	1.14	
		DTS	WLAN	
NII	5GHz WLAN	0.67		1.45
DSS	Bluetooth	Bluetooth		1.41
Date of Testing:			2017/04/07~ 2017/04/17	

This device is in compliance with Specific Absorption Rate (SAR) for general population/uncontrolled exposure limits (1.6 W/kg) specified in FCC 47 CFR part 2 (2.1093) and ANSI/IEEE C95.1-1992, and had been tested in accordance with the measurement methods and procedures specified in IEEE 1528-2013 and FCC KDB publications.

## 2. Administration Data

Testing Laboratory	
Test Site	Sporton International (KunShan) INC.
Test Site Location	No.3-2, Pingxiang Road, Kunshan Development Zone, Jiangsu, China TEL: +86-0512-5790-0158 FAX: +86-0512-5790-0958

Applicant	
Company Name	ZTE CORPORATION
Address	ZTE Plaza, Keji Road South, Hi-Tech Industrial Park, Nanshan District, Shenzhen, Guangdong, 518057, P.R.China

Manufacturer	
Company Name	ZTE CORPORATION
Address	ZTE Plaza, Keji Road South, Hi-Tech Industrial Park, Nanshan District, Shenzhen, Guangdong, 518057, P.R.China

## 3. Guidance Applied

The Specific Absorption Rate (SAR) testing specification, method, and procedure for this device is in accordance with the following standards:

- FCC 47 CFR Part 2 (2.1093)
- ANSI/IEEE C95.1-1992
- IEEE 1528-2013
- FCC KDB 865664 D01 SAR Measurement 100 MHz to 6 GHz v01r04
- FCC KDB 865664 D02 SAR Reporting v01r02
- FCC KDB 447498 D01 General RF Exposure Guidance v06
- FCC KDB 248227 D01 802.11 Wi-Fi SAR v02r02
- FCC KDB 616217 D04 SAR for laptop and tablets v01r02
- FCC KDB 941225 D01 3G SAR Procedures v03r01
- FCC KDB 941225 D05 SAR for LTE Devices v02r05
- FCC KDB 941225 D05A Rel.10 LTE SAR Test Guidance v01r02



4. Equipment Under Test (EUT) Information

4.1 General Information

Product Feature & Specification	
Equipment Name	LTE/WCDMA Tablet
Brand Name	ZTE
Model Name	K92
FCC ID	SRQ-K92
IMEI Code	863862030006760
Wireless Technology and Frequency Range	WCDMA Band II: 1852.4 MHz ~ 1907.6 MHz WCDMA Band IV: 1712.4 MHz ~ 1752.6 MHz WCDMA Band V: 826.4 MHz ~ 846.6 MHz LTE Band 2: 1850.7 MHz ~ 1909.3 MHz LTE Band 4: 1710.7 MHz ~ 1754.3 MHz LTE Band 5: 824.7 MHz ~ 848.3 MHz LTE Band 7: 2502.5 MHz ~ 2567.5 MHz LTE Band 12: 699.7 MHz ~ 715.3 MHz LTE Band 30: 2307.5 MHz ~ 2312.5 MHz WLAN 2.4GHz Band: 2412 MHz ~ 2462 MHz WLAN 5.2GHz Band: 5180 MHz ~ 5240 MHz WLAN 5.8GHz Band: 5745 MHz ~ 5825 MHz Bluetooth: 2402 MHz ~ 2480 MHz
Mode	RMC 12.2Kbps HSDPA HSUPA DC-HSDPA HSPA+ (16QAM uplink is not supported) LTE: QPSK, 16QAM 802.11b/g/n HT20/HT40 802.11a/n HT20/HT40 802.11ac VHT20/VHT40/VHT80 Bluetooth v3.0+EDR, Bluetooth v4.0 LE, Bluetooth v4.1 LE, Bluetooth v4.2 LE
HW Version	K92HWB01
SW Version	K92V1.0.0B01
EUT Stage	Identical Prototype
<b>Remark:</b> 1. This device has no voice function. 2. This device implanted proximity sensor function at Bottom Face, Edge2, power reduction will be implemented immediately for WCDMA Band II/IV/V, LTE Band 2/4/5/7/12/30.	



**4.2 General LTE SAR Test and Reporting Considerations**

Summarized necessary items addressed in KDB 941225 D05 v02r05																																							
FCC ID	SRQ-K92																																						
Equipment Name	LTE/WCDMA Tablet																																						
Operating Frequency Range of each LTE transmission band	LTE Band 2: 1850.7 MHz ~ 1909.3 MHz LTE Band 4: 1710.7 MHz ~ 1754.3 MHz LTE Band 5: 824.7 MHz ~ 848.3 MHz LTE Band 7: 2502.5 MHz ~ 2567.5 MHz LTE Band 12: 699.7 MHz ~ 715.3 MHz LTE Band 30: 2307.5 MHz ~ 2312.5 MHz																																						
Channel Bandwidth	LTE Band 2: 1.4MHz, 3MHz, 5MHz, 10MHz, 15MHz, 20MHz LTE Band 4: 1.4MHz, 3MHz, 5MHz, 10MHz, 15MHz, 20MHz LTE Band 5: 1.4MHz, 3MHz, 5MHz, 10MHz LTE Band 7: 5MHz, 10MHz, 15MHz, 20MHz LTE Band 12: 1.4MHz, 3MHz, 5MHz, 10MHz LTE Band 30: 5MHz, 10MHz																																						
uplink modulations used	QPSK, and 16QAM																																						
LTE Voice / Data requirements	Data only																																						
LTE MPR permanently built-in by design	<p style="text-align: center;"><b>Table 6.2.3-1: Maximum Power Reduction (MPR) for Power Class 3</b></p> <table border="1"> <thead> <tr> <th rowspan="2">Modulation</th> <th colspan="6">Channel bandwidth / Transmission bandwidth (RB)</th> <th rowspan="2">MPR (dB)</th> </tr> <tr> <th>1.4 MHz</th> <th>3.0 MHz</th> <th>5 MHz</th> <th>10 MHz</th> <th>15 MHz</th> <th>20 MHz</th> </tr> </thead> <tbody> <tr> <td>QPSK</td> <td>&gt; 5</td> <td>&gt; 4</td> <td>&gt; 8</td> <td>&gt; 12</td> <td>&gt; 16</td> <td>&gt; 18</td> <td>≤ 1</td> </tr> <tr> <td>16 QAM</td> <td>≤ 5</td> <td>≤ 4</td> <td>≤ 8</td> <td>≤ 12</td> <td>≤ 16</td> <td>≤ 18</td> <td>≤ 1</td> </tr> <tr> <td>16 QAM</td> <td>&gt; 5</td> <td>&gt; 4</td> <td>&gt; 8</td> <td>&gt; 12</td> <td>&gt; 16</td> <td>&gt; 18</td> <td>≤ 2</td> </tr> </tbody> </table>	Modulation	Channel bandwidth / Transmission bandwidth (RB)						MPR (dB)	1.4 MHz	3.0 MHz	5 MHz	10 MHz	15 MHz	20 MHz	QPSK	> 5	> 4	> 8	> 12	> 16	> 18	≤ 1	16 QAM	≤ 5	≤ 4	≤ 8	≤ 12	≤ 16	≤ 18	≤ 1	16 QAM	> 5	> 4	> 8	> 12	> 16	> 18	≤ 2
Modulation	Channel bandwidth / Transmission bandwidth (RB)						MPR (dB)																																
	1.4 MHz	3.0 MHz	5 MHz	10 MHz	15 MHz	20 MHz																																	
QPSK	> 5	> 4	> 8	> 12	> 16	> 18	≤ 1																																
16 QAM	≤ 5	≤ 4	≤ 8	≤ 12	≤ 16	≤ 18	≤ 1																																
16 QAM	> 5	> 4	> 8	> 12	> 16	> 18	≤ 2																																
LTE A-MPR	In the base station simulator configuration, Network Setting value is set to NS_01 to disable A-MPR during SAR testing and the LTE SAR tests was transmitting on all TTI frames (Maximum TTI)																																						
Spectrum plots for RB configuration	A properly configured base station simulator was used for the SAR and power measurement; therefore, spectrum plots for each RB allocation and offset configuration are not included in the SAR report.																																						
Power reduction applied to satisfy SAR compliance	1. Yes, Proximity Sensor. 2. Power reduction will be active at WCDMA Band II/IV/V, LTE Band 2/4/5/7/12/30.																																						
LTE Release	R10,Cat 6																																						
CA Support	Yes																																						
LTE Carrier Aggregation Combinations	Inter-Band possible combinations as below page.																																						
LTE Carrier Aggregation Additional Information	This device does not support full CA features on 3GPP Release 10. It supports a maximum of 2 carriers in the downlink only. All uplink communications are identical to the Release 8 Specifications. Uplink communications are done on the PCC. Due to carrier capability, only the combinations listed above are supported. The following LTE Release features are not supported: Relay, HetNet, Enhanced MIMO, eICI, WiFi Offloading, MDH, eMBMA, Cross-Carrier Scheduling, Enhanced SC-FDMA.																																						



Transmission (H, M, L) channel numbers and frequencies in each LTE band												
LTE Band 2												
	Bandwidth 1.4 MHz		Bandwidth 3 MHz		Bandwidth 5 MHz		Bandwidth 10 MHz		Bandwidth 15 MHz		Bandwidth 20 MHz	
	Ch. #	Freq. (MHz)	Ch. #	Freq. (MHz)	Ch. #	Freq. (MHz)	Ch. #	Freq. (MHz)	Ch. #	Freq. (MHz)	Ch. #	Freq. (MHz)
L	18607	1850.7	18615	1851.5	18625	1852.5	18650	1855	18675	1857.5	18700	1860
M	18900	1880	18900	1880	18900	1880	18900	1880	18900	1880	18900	1880
H	19193	1909.3	19185	1908.5	19175	1907.5	19150	1905	19125	1902.5	19100	1900
LTE Band 4												
	Bandwidth 1.4 MHz		Bandwidth 3 MHz		Bandwidth 5 MHz		Bandwidth 10 MHz		Bandwidth 15 MHz		Bandwidth 20 MHz	
	Ch. #	Freq. (MHz)	Ch. #	Freq. (MHz)	Ch. #	Freq. (MHz)	Ch. #	Freq. (MHz)	Ch. #	Freq. (MHz)	Ch. #	Freq. (MHz)
L	19957	1710.7	19965	1711.5	19975	1712.5	20000	1715	20025	1717.5	20050	1720
M	20175	1732.5	20175	1732.5	20175	1732.5	20175	1732.5	20175	1732.5	20175	1732.5
H	20393	1754.3	20385	1753.5	20375	1752.5	20350	1750	20325	1747.5	20300	1745
LTE Band 5												
	Bandwidth 1.4 MHz		Bandwidth 3 MHz		Bandwidth 5 MHz		Bandwidth 10 MHz					
	Ch. #	Freq. (MHz)	Ch. #	Freq. (MHz)	Ch. #	Freq. (MHz)	Ch. #	Freq. (MHz)	Ch. #	Freq. (MHz)	Ch. #	Freq. (MHz)
L	20407	824.7	20415	825.5	20425	826.5	20450	829				
M	20525	836.5	20525	836.5	20525	836.5	20525	836.5	20525	836.5	20525	836.5
H	20643	848.3	20635	847.5	20625	846.5	20600	844				
LTE Band 7												
	Bandwidth 5 MHz		Bandwidth 10 MHz		Bandwidth 15 MHz		Bandwidth 20 MHz					
	Ch. #	Freq. (MHz)	Ch. #	Freq. (MHz)	Ch. #	Freq. (MHz)	Ch. #	Freq. (MHz)	Ch. #	Freq. (MHz)	Ch. #	Freq. (MHz)
L	20775	2502.5	20800	2505	20825	2507.5	20850	2510				
M	21100	2535	21100	2535	21100	2535	21100	2535	21100	2535	21100	2535
H	21425	2567.5	21400	2565	21375	2562.5	21350	2560				
LTE Band 12												
	Bandwidth 1.4 MHz		Bandwidth 3 MHz		Bandwidth 5 MHz		Bandwidth 10 MHz					
	Ch. #	Freq. (MHz)	Ch. #	Freq. (MHz)	Ch. #	Freq. (MHz)	Ch. #	Freq. (MHz)	Ch. #	Freq. (MHz)	Ch. #	Freq. (MHz)
L	23017	699.7	23025	700.5	23035	701.5	23060	704				
M	23095	707.5	23095	707.5	23095	707.5	23095	707.5	23095	707.5	23095	707.5
H	23173	715.3	23165	714.5	23155	713.5	23130	711				
LTE Band 30												
	Bandwidth 5 MHz				Bandwidth 10 MHz							
	Channel #		Freq.(MHz)		Channel #		Freq.(MHz)					
L	27685		2307.5		27710		2310					
M	27710		2310									
H	27735		2312.5									

LTE Carrier Aggregation Combinations																			
Inter-Band Combinations																			
(PCC) B2	(SCC) B5	(PCC) B5	(SCC) B2	(PCC) B2	(SCC) B12	(PCC) B12	(SCC) B2	(PCC) B2	(SCC) B29	(PCC) B4	(SCC) B5	(PCC) B5	(SCC) B4	(PCC) B4	(SCC) B12	(PCC) B12	(SCC) B4	(PCC) B4	(SCC) B29
20M + 10M	10M + 20M	20M + 10M	10M + 20M	20M + 10M	10M + 20M	20M + 10M	10M + 20M	20M + 10M	10M + 20M	20M + 10M	10M + 20M	20M + 10M	10M + 20M	20M + 10M	10M + 20M	20M + 10M	10M + 20M	20M + 10M	10M + 20M
20M + 5M	10M + 15M	20M + 5M	10M + 15M	20M + 5M	10M + 15M	20M + 5M	10M + 15M	20M + 5M	10M + 15M	20M + 5M	10M + 15M	20M + 5M	10M + 15M	20M + 5M	10M + 15M	20M + 5M	10M + 15M	20M + 5M	10M + 15M
15M + 10M	10M + 10M	20M + 3M	10M + 10M	20M + 3M	10M + 10M	20M + 3M	15M + 10M	10M + 10M	20M + 3M	15M + 10M	10M + 10M	20M + 3M	10M + 10M	20M + 3M	10M + 10M	20M + 3M	10M + 10M	20M + 3M	10M + 10M
15M + 5M	10M + 5M	15M + 10M	10M + 5M	15M + 10M	10M + 5M	15M + 10M	15M + 5M	10M + 5M	15M + 10M	15M + 5M	10M + 5M	15M + 10M	10M + 5M	15M + 10M	10M + 5M	15M + 10M	10M + 5M	15M + 10M	15M + 10M
10M + 10M	5M + 20M	15M + 5M	5M + 20M	15M + 5M	5M + 20M	15M + 5M	10M + 10M	5M + 20M	15M + 5M	10M + 10M	5M + 20M	15M + 5M	10M + 10M	15M + 5M	10M + 3M	15M + 5M	10M + 3M	15M + 5M	15M + 5M
10M + 5M	5M + 15M	15M + 3M	5M + 15M	15M + 3M	5M + 15M	15M + 3M	10M + 5M	5M + 15M	15M + 3M	10M + 5M	5M + 15M	15M + 3M	10M + 5M	15M + 3M	10M + 1.4M	15M + 3M	10M + 1.4M	15M + 3M	15M + 3M
5M + 10M	5M + 10M	10M + 10M	5M + 10M	10M + 10M	5M + 10M	10M + 10M	5M + 10M	5M + 10M	10M + 10M	5M + 10M	5M + 10M	10M + 10M	5M + 10M	10M + 10M	5M + 20M	10M + 10M	5M + 20M	10M + 10M	10M + 10M
5M + 5M	5M + 5M	10M + 5M	5M + 5M	10M + 5M	5M + 5M	10M + 5M	5M + 5M	5M + 5M	10M + 5M	5M + 5M	5M + 5M	10M + 5M	5M + 5M	10M + 5M	5M + 15M	10M + 5M	5M + 15M	10M + 5M	10M + 5M
		10M + 3M	3M + 20M	10M + 3M										10M + 3M	5M + 10M	10M + 3M	5M + 10M	10M + 3M	10M + 3M
		5M + 10M	3M + 15M	5M + 10M										5M + 10M	5M + 5M	5M + 10M	5M + 5M	5M + 10M	5M + 10M
		5M + 5M	3M + 10M	5M + 5M										5M + 5M	5M + 3M	5M + 5M	5M + 3M	5M + 5M	5M + 5M
		5M + 3M	3M + 5M	5M + 3M										5M + 3M	5M + 1.4M	5M + 3M	5M + 1.4M	5M + 3M	5M + 3M
														3M + 10M	3M + 20M				
														3M + 5M	3M + 15M				
														3M + 3M	3M + 10M				
														1.4M + 10M	3M + 5M				
														1.4M + 5M	3M + 3M				
														1.4M + 3M	3M + 1.4M				

**General Note:** This device supports LTE Carrier Aggregation (CA) in the downlink only.

## 5. Proximity Sensor Triggering Test

### <Proximity Sensor Triggering Distance (KDB 616217 D04 section 6.2)>:

Proximity sensor triggering distance testing was performed according to the procedures outlined in KDB 616217 D04 section 6.2, and EUT moving further away from the flat phantom and EUT moving toward the flat phantom were both assessed. The details are illustrated in the exhibit “P-Sensor operational description”, and the shortest triggering distances were reported and used for SAR assessment.

In the preliminary triggering distance testing, the tissue-equivalent medium for different frequency bands were used for verification; no other frequency bands tissue-equivalent medium was found to result in shortest triggering distance than that for 1900MHz, and the tissue-equivalent medium for 1900MHz was used for formal proximity sensor triggering testing.

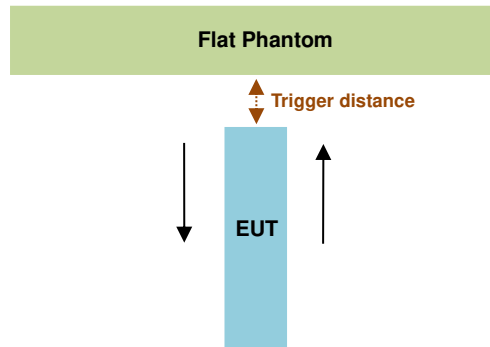

Proximity Sensor Triggering Distance (mm)		
Position	Bottom Face	Edge 2
Minimum	22	22

### <Proximity Sensor Triggering Coverage (KDB 616217 D04 section 6.3)>:

If a sensor is spatially offset from the antenna(s), it is necessary to verify sensor triggering for conditions where the antenna is next to the user but the sensor is laterally further away to ensure sensor coverage is sufficient for reducing the power to maintain compliance. For p-sensor coverage testing, the device is moved and “along the direction of maximum antenna and sensor offset”.

Illustrated in the internal photo exhibit, although the sensor is spatially offset, there is no trigger condition where the antenna is next to the user but the sensor is laterally further away, therefore proximity sensor coverage testing is not required.

This procedure is not required because antenna and sensor are collocated and the peak SAR location is overlapping with the sensor.

**<Tablet Tilt angle influences to proximity sensor triggering (KDB 616217 D04 section 6.4)>:**

The influence of table tilt angles to proximity sensor triggering was determined by positioning each tablet edge that contains a transmitting antenna, perpendicular to the flat phantom, at 22 mm separation. Rotating the tablet around the edge next to the phantom in  $\leq 10^\circ$  increments until the tablet is  $\pm 45^\circ$  from the vertical position at  $0^\circ$ , and the maximum output power remains in the reduced mode.

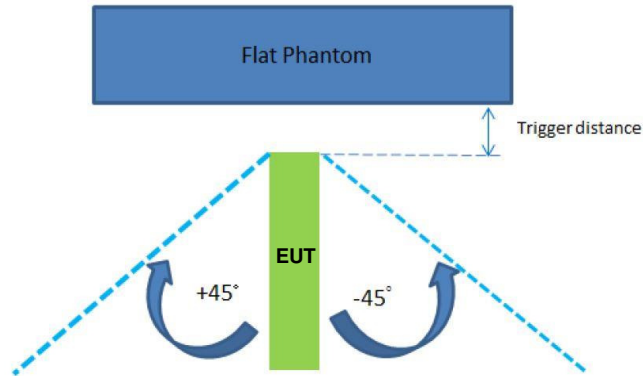

The Sensor Trigger Distance (mm)	
Position	Edge 2
Minimum	22

**Proximity sensor power reduction**

Exposure Position / wireless mode	Bottom Face <sup>(1)</sup>	Edge 1	Edge 2 <sup>(1)</sup>	Edge 3	Edge 4
WCDMA Band V	3.0 dB	0 dB	3.0 dB	0 dB	0 dB
WCDMA Band II	9.0 dB	0 dB	9.0 dB	0 dB	0 dB
WCDMA Band IV	8.0 dB	0 dB	8.0 dB	0 dB	0 dB
LTE Band 2	9.5 dB	0 dB	9.5 dB	0 dB	0 dB
LTE Band 4	8.0 dB	0 dB	8.0 dB	0 dB	0 dB
LTE Band 5	3.0 dB	0 dB	3.0 dB	0 dB	0 dB
LTE Band 7	12.0 dB	0 dB	12.0 dB	0 dB	0 dB
LTE Band 12	2.0 dB	0 dB	2.0 dB	0 dB	0 dB
LTE Band 30	8.0 dB	0 dB	8.0 dB	0 dB	0 dB

**Remark:**

1. <sup>(1)</sup>: Reduced maximum limit applied by activation of proximity sensor.
2. Power reduction is not applicable for WLAN and Bluetooth.
3. Tests were performed in accordance with KDB 616217 D04 section 6.1, 6.2, 6.3, 6.4 and 6.5 and compliant results are shown and described in exhibit "P-Sensor operational description"
4. For verification of compliance of power reduction scheme, additional SAR testing with EUT transmitting at full RF power at a conservative trigger distance was performed:
  - Bottom Face: 13 mm
  - Edge 2: 18 mm

Power Measurement during Sensor Trigger distance testing

Band/Mode	Ch #	Measured power reduction (dBm)		Reduction Levels (dB)
		w/o power back-off	w/ power back-off	
WCDMA Band V (RMC 12.2Kbps)	4182	23.35	20.38	2.97
WCDMA Band IV (RMC 12.2Kbps)	1413	23.19	15.04	8.15
WCDMA Band II (RMC 12.2Kbps)	9400	23.28	14.03	9.25
LTE Band 2 (20MHz 1RB 49offset)	18900	23.03	13.65	9.38
LTE Band 4 (20MHz 1RB 49offset)	20175	23.32	15.23	8.09
LTE Band 5 (10MHz 1RB 0offset)	20525	23.17	19.98	3.19
LTE Band 7 (20MHz 1RB 49offset)	21100	23.23	10.79	12.44
LTE Band 12 (10MHz 1RB 25offset)	23095	22.83	21.33	1.50
LTE Band 30 (20MHz 1RB 25offset)	27710	23.67	15.79	7.88

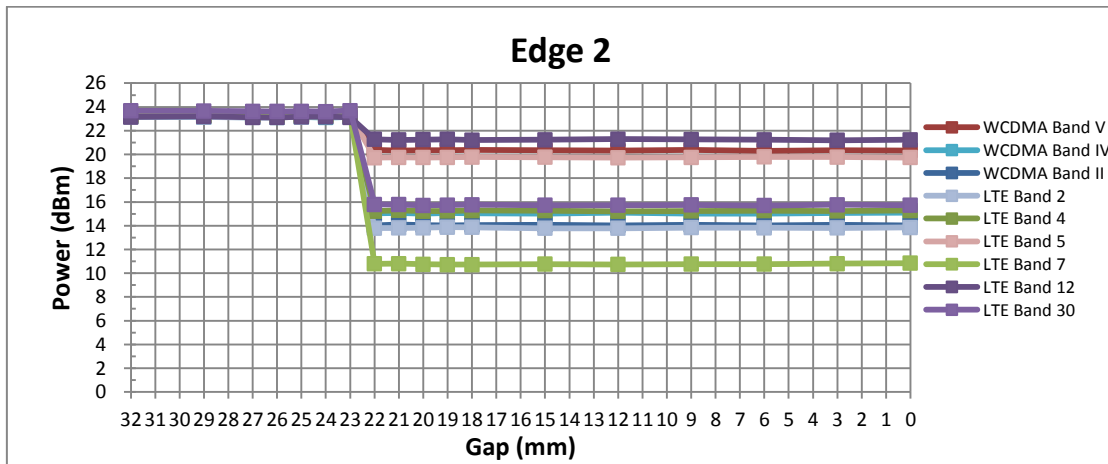
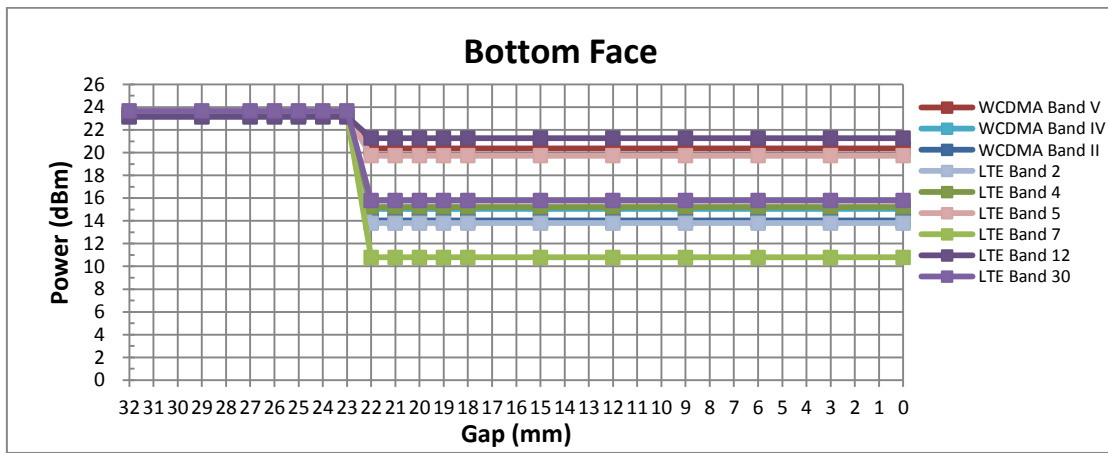

**6. RF Exposure Limits**

**6.1 Uncontrolled Environment**

Uncontrolled Environments are defined as locations where there is the exposure of individuals who have no knowledge or control of their exposure. The general population/uncontrolled exposure limits are applicable to situations in which the general public may be exposed or in which persons who are exposed as a consequence of their employment may not be made fully aware of the potential for exposure or cannot exercise control over their exposure. Members of the general public would come under this category when exposure is not employment-related; for example, in the case of a wireless transmitter that exposes persons in its vicinity.

**6.2 Controlled Environment**

Controlled Environments are defined as locations where there is exposure that may be incurred by persons who are aware of the potential for exposure, (i.e. as a result of employment or occupation). In general, occupational/controlled exposure limits are applicable to situations in which persons are exposed as a consequence of their employment, who have been made fully aware of the potential for exposure and can exercise control over their exposure. The exposure category is also applicable when the exposure is of a transient nature due to incidental passage through a location where the exposure levels may be higher than the general population/uncontrolled limits, but the exposed person is fully aware of the potential for exposure and can exercise control over his or her exposure by leaving the area or by some other appropriate means.

**Limits for Occupational/Controlled Exposure (W/kg)**

Whole-Body	Partial-Body	Hands, Wrists, Feet and Ankles
0.4	8.0	20.0

**Limits for General Population/Uncontrolled Exposure (W/kg)**

Whole-Body	Partial-Body	Hands, Wrists, Feet and Ankles
0.08	1.6	4.0

Whole-Body SAR is averaged over the entire body, partial-body SAR is averaged over any 1gram of tissue defined as a tissue volume in the shape of a cube. SAR for hands, wrists, feet and ankles is averaged over any 10 grams of tissue defined as a tissue volume in the shape of a cube.

## **7. Specific Absorption Rate (SAR)**

### **7.1 Introduction**

SAR is related to the rate at which energy is absorbed per unit mass in an object exposed to a radio field. The SAR distribution in a biological body is complicated and is usually carried out by experimental techniques or numerical modeling. The standard recommends limits for two tiers of groups, occupational/controlled and general population/uncontrolled, based on a person's awareness and ability to exercise control over his or her exposure. In general, occupational/controlled exposure limits are higher than the limits for general population/uncontrolled.

### **7.2 SAR Definition**

The SAR definition is the time derivative (rate) of the incremental energy (dW) absorbed by (dissipated in) an incremental mass (dm) contained in a volume element (dv) of a given density ( $\rho$ ). The equation description is as below:

$$SAR = \frac{d}{dt} \left( \frac{dW}{dm} \right) = \frac{d}{dt} \left( \frac{dW}{\rho dv} \right)$$

SAR is expressed in units of Watts per kilogram (W/kg)

$$SAR = \frac{\sigma |E|^2}{\rho}$$

Where:  $\sigma$  is the conductivity of the tissue,  $\rho$  is the mass density of the tissue and E is the RMS electrical field strength.

## 8. System Description and Setup

The DASY system used for performing compliance tests consists of the following items:

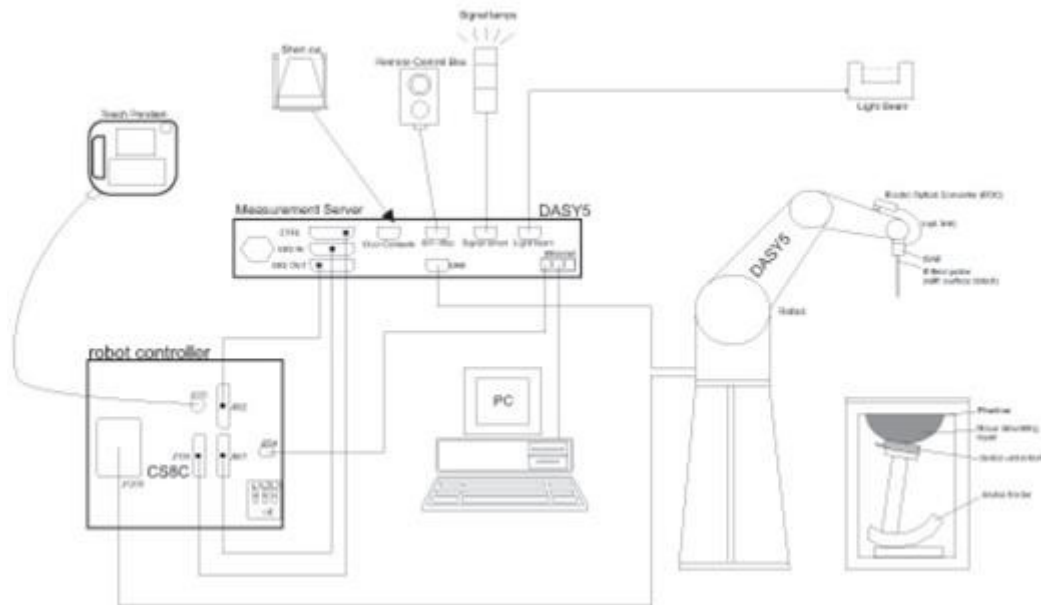

- A standard high precision 6-axis robot with controller, teach pendant and software. An arm extension for accommodating the data acquisition electronics (DAE).
- An isotropic Field probe optimized and calibrated for the targeted measurement.
- A data acquisition electronics (DAE) which performs the signal amplification, signal multiplexing, AD-conversion, offset measurements, mechanical surface detection, collision detection, etc. The unit is battery powered with standard or rechargeable batteries. The signal is optically transmitted to the EOC.
- The Electro-optical converter (EOC) performs the conversion from optical to electrical signals for the digital communication to the DAE. To use optical surface detection, a special version of the EOC is required. The EOC signal is transmitted to the measurement server.
- The function of the measurement server is to perform the time critical tasks such as signal filtering, control of the robot operation and fast movement interrupts.
- The Light Beam used is for probe alignment. This improves the (absolute) accuracy of the probe positioning.
- A computer running WinXP or Win7 and the DASY5 software.
- Remote control and teach pendant as well as additional circuitry for robot safety such as warning lamps, etc.
- The phantom, the device holder and other accessories according to the targeted measurement.

**8.1 E-Field Probe**

The SAR measurement is conducted with the dosimetric probe (manufactured by SPEAG).The probe is specially designed and calibrated for use in liquid with high permittivity. The dosimetric probe has special calibration in liquid at different frequency. This probe has a built in optical surface detection system to prevent from collision with phantom.

**<EX3DV4 Probe>**

<b>Construction</b>	Symmetric design with triangular core Built-in shielding against static charges PEEK enclosure material (resistant to organic solvents, e.g., DGBE)
<b>Frequency</b>	10 MHz – >6 GHz Linearity: ±0.2 dB (30 MHz – 6 GHz)
<b>Directivity</b>	±0.3 dB in TSL (rotation around probe axis) ±0.5 dB in TSL (rotation normal to probe axis)
<b>Dynamic Range</b>	10 µW/g – >100 mW/g Linearity: ±0.2 dB (noise: typically <1 µW/g)
<b>Dimensions</b>	Overall length: 337 mm (tip: 20 mm) Tip diameter: 2.5 mm (body: 12 mm) Typical distance from probe tip to dipole centers: 1 mm



**8.2 Data Acquisition Electronics (DAE)**

The data acquisition electronics (DAE) consists of a highly sensitive electrometer-grade preamplifier with auto-zeroing, a channel and gain-switching multiplexer, a fast 16 bit AD-converter and a command decoder and control logic unit. Transmission to the measurement server is accomplished through an optical downlink for data and status information as well as an optical uplink for commands and the clock.

The input impedance of the DAE is 200 MOhm; the inputs are symmetrical and floating. Common mode rejection is above 80 dB.



**Fig 5.1 Photo of DAE**

**8.3 Phantom**

**<ELI Phantom>**

<b>Shell Thickness</b>	2 ± 0.2 mm (sagging: <1%)
<b>Filling Volume</b>	Approx. 30 liters
<b>Dimensions</b>	Major ellipse axis: 600 mm Minor axis: 400 mm



The ELI phantom is intended for compliance testing of handheld and body-mounted wireless devices in the frequency range of 30 MHz to 6 GHz. ELI4 is fully compatible with standard and all known tissue simulating liquids.

## 8.4 Device Holder

### <Mounting Device for Hand-Held Transmitter>

In combination with the Twin SAM V5.0/V5.0c or ELI phantoms, the Mounting Device for Hand-Held Transmitters enables rotation of the mounted transmitter device to specified spherical coordinates. At the heads, the rotation axis is at the ear opening. Transmitter devices can be easily and accurately positioned according to IEC 62209-1, IEEE 1528, FCC, or other specifications. The device holder can be locked for positioning at different phantom sections (left head, right head, flat). And upgrade kit to Mounting Device to enable easy mounting of wider devices like big smart-phones, e-books, small tablets, etc. It holds devices with width up to 140 mm.



Mounting Device for Hand-Held Transmitters



Mounting Device Adaptor for Wide-Phones

### <Mounting Device for Laptops and other Body-Worn Transmitters>

The extension is lightweight and made of POM, acrylic glass and foam. It fits easily on the upper part of the mounting device in place of the phone positioned. The extension is fully compatible with the SAM Twin and ELI phantoms.



Mounting Device for Laptops

## **9. Measurement Procedures**

The measurement procedures are as follows:

### <Conducted power measurement>

- (a) For WWAN power measurement, use base station simulator to configure EUT WWAN transmission in conducted connection with RF cable, at maximum power in each supported wireless interface and frequency band.
- (b) Read the WWAN RF power level from the base station simulator.
- (c) For WLAN/BT power measurement, use engineering software to configure EUT WLAN/BT continuously transmission, at maximum RF power in each supported wireless interface and frequency band
- (d) Connect EUT RF port through RF cable to the power meter, and measure WLAN/BT output power

### <SAR measurement>

- (a) Use base station simulator to configure EUT WWAN transmission in radiated connection, and engineering software to configure EUT WLAN/BT continuously transmission, at maximum RF power, in the highest power channel.
- (b) Place the EUT in the positions as Appendix D demonstrates.
- (c) Set scan area, grid size and other setting on the DASY software.
- (d) Measure SAR results for the highest power channel on each testing position.
- (e) Find out the largest SAR result on these testing positions of each band
- (f) Measure SAR results for other channels in worst SAR testing position if the reported SAR of highest power channel is larger than 0.8 W/kg

According to the test standard, the recommended procedure for assessing the peak spatial-average SAR value consists of the following steps:

- (a) Power reference measurement
- (b) Area scan
- (c) Zoom scan
- (d) Power drift measurement

### **9.1 Spatial Peak SAR Evaluation**

The procedure for spatial peak SAR evaluation has been implemented according to the test standard. It can be conducted for 1g and 10g, as well as for user-specific masses. The DASY software includes all numerical procedures necessary to evaluate the spatial peak SAR value.

The base for the evaluation is a "cube" measurement. The measured volume must include the 1g and 10g cubes with the highest averaged SAR values. For that purpose, the center of the measured volume is aligned to the interpolated peak SAR value of a previously performed area scan.

The entire evaluation of the spatial peak values is performed within the post-processing engine (SEMCAD). The system always gives the maximum values for the 1g and 10g cubes. The algorithm to find the cube with highest averaged SAR is divided into the following stages:

- (a) Extraction of the measured data (grid and values) from the Zoom Scan
- (b) Calculation of the SAR value at every measurement point based on all stored data (A/D values and measurement parameters)
- (c) Generation of a high-resolution mesh within the measured volume
- (d) Interpolation of all measured values from the measurement grid to the high-resolution grid
- (e) Extrapolation of the entire 3-D field distribution to the phantom surface over the distance from sensor to surface
- (f) Calculation of the averaged SAR within masses of 1g and 10g

**9.2 Power Reference Measurement**

The Power Reference Measurement and Power Drift Measurements are for monitoring the power drift of the device under test in the batch process. The minimum distance of probe sensors to surface determines the closest measurement point to phantom surface. This distance cannot be smaller than the distance of sensor calibration points to probe tip as defined in the probe properties.

**9.3 Area Scan**

The area scan is used as a fast scan in two dimensions to find the area of high field values, before doing a fine measurement around the hot spot. The sophisticated interpolation routines implemented in DASY software can find the maximum found in the scanned area, within a range of the global maximum. The range (in dB0 is specified in the standards for compliance testing. For example, a 2 dB range is required in IEEE standard 1528 and IEC 62209 standards, whereby 3 dB is a requirement when compliance is assessed in accordance with the ARIB standard (Japan), if only one zoom scan follows the area scan, then only the absolute maximum will be taken as reference. For cases where multiple maximums are detected, the number of zoom scans has to be increased accordingly.

Area scan parameters extracted from FCC KDB 865664 D01v01r04 SAR measurement 100 MHz to 6 GHz.

	≤ 3 GHz	> 3 GHz
Maximum distance from closest measurement point (geometric center of probe sensors) to phantom surface	5 ± 1 mm	$\frac{1}{2} \cdot \delta \cdot \ln(2) \pm 0.5$ mm
Maximum probe angle from probe axis to phantom surface normal at the measurement location	30° ± 1°	20° ± 1°
Maximum area scan spatial resolution: $\Delta x_{Area}, \Delta y_{Area}$	≤ 2 GHz: ≤ 15 mm 2 – 3 GHz: ≤ 12 mm	3 – 4 GHz: ≤ 12 mm 4 – 6 GHz: ≤ 10 mm
	When the x or y dimension of the test device, in the measurement plane orientation, is smaller than the above, the measurement resolution must be ≤ the corresponding x or y dimension of the test device with at least one measurement point on the test device.	

**9.4 Zoom Scan**

Zoom scans are used assess the peak spatial SAR values within a cubic averaging volume containing 1 gram and 10 gram of simulated tissue. The zoom scan measures points (refer to table below) within a cube shoes base faces are centered on the maxima found in a preceding area scan job within the same procedure. When the measurement is done, the zoom scan evaluates the averaged SAR for 1 gram and 10 gram and displays these values next to the job's label.

Zoom scan parameters extracted from FCC KDB 865664 D01v01r04 SAR measurement 100 MHz to 6 GHz.

		≤ 3 GHz	> 3 GHz	
Maximum zoom scan spatial resolution: $\Delta x_{Zoom}, \Delta y_{Zoom}$		$\leq 2$ GHz: $\leq 8$ mm 2 – 3 GHz: $\leq 5$ mm*	3 – 4 GHz: $\leq 5$ mm* 4 – 6 GHz: $\leq 4$ mm*	
Maximum zoom scan spatial resolution, normal to phantom surface	uniform grid: $\Delta z_{Zoom}(n)$	$\leq 5$ mm	3 – 4 GHz: $\leq 4$ mm 4 – 5 GHz: $\leq 3$ mm 5 – 6 GHz: $\leq 2$ mm	
	graded grid	$\Delta z_{Zoom}(1)$ : between 1 <sup>st</sup> two points closest to phantom surface	$\leq 4$ mm	3 – 4 GHz: $\leq 3$ mm 4 – 5 GHz: $\leq 2.5$ mm 5 – 6 GHz: $\leq 2$ mm
		$\Delta z_{Zoom}(n>1)$ : between subsequent points	$\leq 1.5 \cdot \Delta z_{Zoom}(n-1)$	
Minimum zoom scan volume	x, y, z	$\geq 30$ mm	3 – 4 GHz: $\geq 28$ mm 4 – 5 GHz: $\geq 25$ mm 5 – 6 GHz: $\geq 22$ mm	
Note: $\delta$ is the penetration depth of a plane-wave at normal incidence to the tissue medium; see draft standard IEEE P1528-2011 for details. * When zoom scan is required and the <i>reported</i> SAR from the <i>area scan based 1-g SAR estimation</i> procedures of KDB 447498 is $\leq 1.4$ W/kg, $\leq 8$ mm, $\leq 7$ mm and $\leq 5$ mm zoom scan resolution may be applied, respectively, for 2 GHz to 3 GHz, 3 GHz to 4 GHz and 4 GHz to 6 GHz.				

**9.5 Volume Scan Procedures**

The volume scan is used for assess overlapping SAR distributions for antennas transmitting in different frequency bands. It is equivalent to an oversized zoom scan used in standalone measurements. The measurement volume will be used to enclose all the simultaneous transmitting antennas. For antennas transmitting simultaneously in different frequency bands, the volume scan is measured separately in each frequency band. In order to sum correctly to compute the 1g aggregate SAR, the EUT remain in the same test position for all measurements and all volume scan use the same spatial resolution and grid spacing. When all volume scan were completed, the software, SEMCAD postprocessor can combine and subsequently superpose these measurement data to calculating the multiband SAR.

**9.6 Power Drift Monitoring**

All SAR testing is under the EUT install full charged battery and transmit maximum output power. In DASy measurement software, the power reference measurement and power drift measurement procedures are used for monitoring the power drift of EUT during SAR test. Both these procedures measure the field at a specified reference position before and after the SAR testing. The software will calculate the field difference in dB. If the power drifts more than 5%, the SAR will be retested.



**10. Test Equipment List**

Manufacturer	Name of Equipment	Type/Model	Serial Number	Calibration	
				Last Cal.	Due Date
SPEAG	750MHz System Validation Kit	D750V3	1065	2016/11/21	2017/11/20
SPEAG	835MHz System Validation Kit	D835V2	4d091	2016/11/22	2017/11/21
SPEAG	1750MHz System Validation Kit	D1750V2	1069	2016/11/23	2017/11/22
SPEAG	1900MHz System Validation Kit	D1900V2	5d118	2016/11/24	2017/11/23
SPEAG	2300MHz System Validation Kit	D2300V2	1055	2016/8/31	2017/8/30
SPEAG	2450MHz System Validation Kit	D2450V2	840	2016/11/25	2017/11/24
SPEAG	2600MHz System Validation Kit	D2600V2	1061	2016/11/24	2017/11/23
SPEAG	5000MHz System Validation Kit	D5GHzV2	1113	2016/12/13	2017/12/12
SPEAG	Data Acquisition Electronics	DAE4	1210	2016/5/18	2017/5/17
SPEAG	Dosimetric E-Field Probe	EX3DV4	3857	2016/5/25	2017/5/24
SPEAG	ELI4 Phantom	QD OVA 001 BB	TP-1079	NCR	NCR
SPEAG	Phone Positioner	N/A	N/A	NCR	NCR
Anritsu	Radio communication analyzer	MT8820C	6201563814	2017/1/19	2018/1/18
Agilent	Wireless Communication Test Set	E5515C	MY52102706	2016/4/22	2017/4/21
Agilent	ENA Series Network Analyzer	E5071C	MY46111157	2016/4/22	2017/4/21
SPEAG	DAK Kit	DAK3.5	1144	2016/11/23	2017/11/22
R&S	Signal Generator	SMR40	100455	2017/1/19	2018/1/18
Anritsu	Power Sensor	MA2411B	1644003	2016/12/23	2017/12/22
Anritsu	Power Meter	ML2495A	1531197	2016/12/23	2017/12/22
Anritsu	Power Sensor	MA2411B	1644004	2016/12/23	2017/12/22
Anritsu	Power Meter	ML2495A	1531198	2016/12/23	2017/12/22
R&S	Spectrum Analyzer	FSV7	101631	2016/8/8	2017/8/7
ARRA	Power Divider	A3200-2	N/A	Note 1	
Agilent	Dual Directional Coupler	778D	50422	Note 1	
PASTERNAK	Dual Directional Coupler	PE2214-10	N/A	Note 1	
MCL	Attenuation1	BW-S10W5+	N/A	Note 1	
MCL	Attenuation2	BW-S10W5+	N/A	Note 1	
MCL	Attenuation3	BW-S10W5+	N/A	Note 1	
AR	Amplifier	5S1G4	333096	Note 1	
mini-circuits	Amplifier	ZVE-3W-83+	162601250	Note 1	

**General Note:**

1. Prior to system verification and validation, the path loss from the signal generator to the system check source and the power meter, which includes the amplifier, cable, attenuator and directional coupler, was measured by the network analyzer. The reading of the power meter was offset by the path loss difference between the path to the power meter and the path to the system check source to monitor the actual power level fed to the system check source.

## **11. System Verification**

### **11.1 Tissue Simulating Liquids**

For the measurement of the field distribution inside the SAM phantom with DASYS, the phantom must be filled with around 25 liters of homogeneous body tissue simulating liquid. For body SAR testing, the liquid height from the center of the flat phantom to the liquid top surface is larger than 15 cm, which is shown in Fig. 10.1.

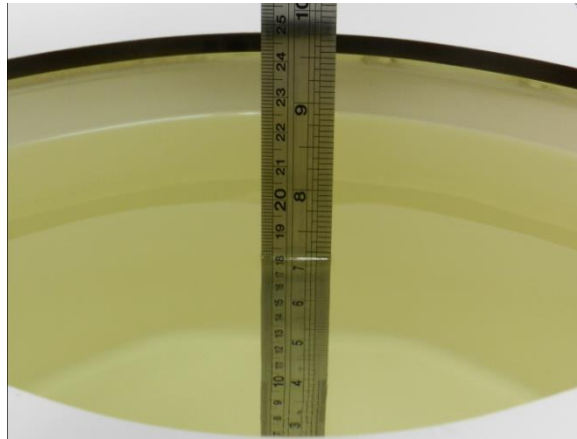

**Fig 10.1 Photo of Liquid Height for Body SAR**

**11.2 Tissue Verification**

The following tissue formulations are provided for reference only as some of the parameters have not been thoroughly verified. The composition of ingredients may be modified accordingly to achieve the desired target tissue parameters required for routine SAR evaluation.

Frequency (MHz)	Water (%)	Sugar (%)	Cellulose (%)	Salt (%)	Preventol (%)	DGBE (%)	Conductivity ( $\sigma$ )	Permittivity ( $\epsilon_r$ )
For Body								
750	51.7	47.2	0	0.9	0.1	0	0.96	55.5
835	50.8	48.2	0	0.9	0.1	0	0.97	55.2
1800, 1900, 2000	70.2	0	0	0.4	0	29.4	1.52	53.3
2450	68.6	0	0	0	0	31.4	1.95	52.7
2600	68.1	0	0	0.1	0	31.8	2.16	52.5

**Simulating Liquid for 5GHz, Manufactured by SPEAG**

Ingredients	(% by weight)
Water	64~78%
Mineral oil	11~18%
Emulsifiers	9~15%
Additives and Salt	2~3%

**<Tissue Dielectric Parameter Check Results>**

Frequency (MHz)	Tissue Type	Liquid Temp. (°C)	Conductivity ( $\sigma$ )	Permittivity ( $\epsilon_r$ )	Conductivity Target ( $\sigma$ )	Permittivity Target ( $\epsilon_r$ )	Delta ( $\sigma$ ) (%)	Delta ( $\epsilon_r$ ) (%)	Limit (%)	Date
750	Body	22.8	0.962	55.591	0.96	55.50	0.21	0.16	±5	2017/4/11
835	Body	22.8	0.979	54.170	0.97	55.20	0.93	-1.87	±5	2017/4/11
1750	Body	22.7	1.439	53.020	1.49	53.40	-3.42	-0.71	±5	2017/4/7
1900	Body	22.7	1.532	54.060	1.52	53.30	0.79	1.43	±5	2017/4/9
2300	Body	22.5	1.783	53.164	1.81	52.90	-1.49	0.50	±5	2017/4/10
2450	Body	22.6	1.917	53.459	1.95	52.70	-1.69	1.44	±5	2017/4/16
2600	Body	22.5	2.196	52.103	2.16	52.50	1.67	-0.76	±5	2017/4/11
5250	Body	22.7	5.366	48.688	5.36	48.95	0.11	-0.54	±5	2017/4/17
5750	Body	22.7	6.234	48.199	5.94	48.28	4.95	-0.17	±5	2017/4/17

**11.3 System Performance Check Results**

Comparing to the original SAR value provided by SPEAG, the verification data should be within its specification of 10 %. Below table shows the target SAR and measured SAR after normalized to 1W input power. The table below indicates the system performance check can meet the variation criterion and the plots can be referred to Appendix A of this report.

Date	Frequency (MHz)	Tissue Type	Input Power (mW)	Dipole S/N	Probe S/N	DAE S/N	Measured 1g SAR (W/kg)	Targeted 1g SAR (W/kg)	Normalized 1g SAR (W/kg)	Deviation (%)
2017/4/11	750	Body	250	1065	3857	1210	2.18	8.71	8.72	0.11
2017/4/11	835	Body	250	4d091	3857	1210	2.26	9.68	9.04	-6.61
2017/4/7	1750	Body	250	1069	3857	1210	9.38	37.70	37.52	-0.48
2017/4/9	1900	Body	250	5d118	3857	1210	10.30	40.80	41.2	0.98
2017/4/10	2300	Body	250	1055	3857	1210	12.70	49.40	50.8	2.83
2017/4/16	2450	Body	250	840	3857	1210	13.20	50.90	52.8	3.73
2017/4/11	2600	Body	250	1061	3857	1210	13.80	55.40	55.2	-0.36
2017/4/17	5250	Body	100	1113	3857	1210	7.69	76.10	76.9	1.05
2017/4/17	5750	Body	100	1113	3857	1210	7.76	75.20	77.6	3.19

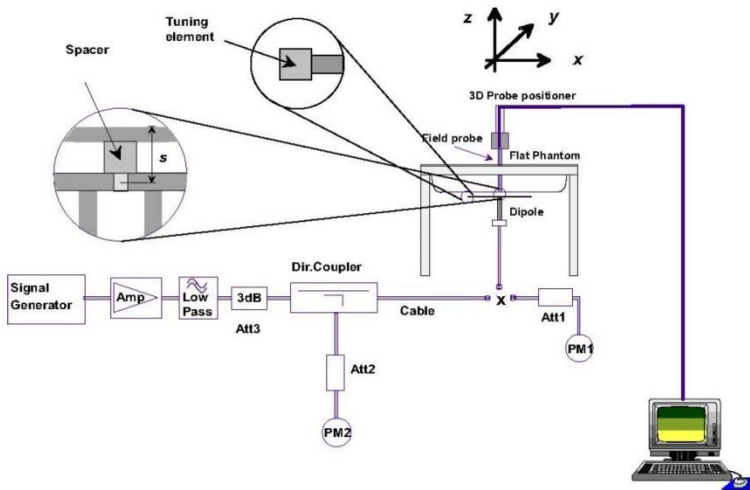

**Fig 8.3.1 System Performance Check Setup**



**Fig 8.3.2 Setup Photo**



## **12. RF Exposure Positions**

### **12.1 SAR Testing for Tablet**

This device can be used also in full sized tablet exposure conditions, due to its size. Per FCC KDB 616217, the back surface and edges of the tablet should be tested for SAR compliance with the tablet touching the phantom. The SAR exclusion threshold in KDB 447498 D01v06 can be applied to determine SAR test exclusion for adjacent edge configurations. The closest distance from the antenna to an adjacent tablet edge is used to determine if SAR testing is required for the adjacent edges, with the adjacent edge positioned against the phantom and the edge containing the antenna positioned perpendicular to the phantom.

This EUT was tested in four different positions. They are bottom-face, Edge1, Edge2 and Edge4. EUT has proximity sensor function, it would be on bottom-face and Edge2, the distance is 13 mm for bottom-face, 18mm for Edge2, EUT transmitting reduced power was performed. Additional the surface of EUT is touching with phantom 0 cm for Edge1 and Edge 4 with full power.

### 13. Conducted RF Output Power (Unit: dBm)

**<WCDMA Conducted Power>**

1. The following tests were conducted according to the test requirements outlines in 3GPP TS 34.121 specification.
2. The procedures in KDB 941225 D01v03r01 are applied for 3GPP Rel. 6 HSPA to configure the device in the required sub-test mode(s) to determine SAR test exclusion.
3. For DC-HSDPA, the device was configured according to the H-Set 12, Fixed Reference Channel (FRC) configuration in Table C.8.1.12 of 3GPP TS 34.121-1, with the primary and the secondary serving HS-DSCH Cell enabled during the power measurement.

A summary of these settings are illustrated below:

**HSDPA Setup Configuration:**

- a. The EUT was connected to Base Station Agilent E5515C referred to the Setup Configuration.
- b. The RF path losses were compensated into the measurements.
- c. A call was established between EUT and Base Station with following setting:
  - i. Set Gain Factors ( $\beta_c$  and  $\beta_d$ ) and parameters were set according to each
  - ii. Specific sub-test in the following table, C10.1.4, quoted from the TS 34.121
  - iii. Set RMC 12.2Kbps + HSDPA mode.
  - iv. Set Cell Power = -86 dBm
  - v. Set HS-DSCH Configuration Type to FRC (H-set 1, QPSK)
  - vi. Select HSDPA Uplink Parameters
  - vii. Set Delta ACK, Delta NACK and Delta CQI = 8
  - viii. Set Ack-Nack Repetition Factor to 3
  - ix. Set CQI Feedback Cycle (k) to 4 ms
  - x. Set CQI Repetition Factor to 2
  - xi. Power Ctrl Mode = All Up bits
- d. The transmitted maximum output power was recorded.

**Table C.10.1.4:  $\beta$  values for transmitter characteristics tests with HS-DPCCH**

Sub-test	$\beta_c$	$\beta_d$	$\beta_d$ (SF)	$\beta_c/\beta_d$	$\beta_{HS}$ (Note 1, Note 2)	CM (dB) (Note 3)	MPR (dB) (Note 3)
1	2/15	15/15	64	2/15	4/15	0.0	0.0
2	12/15 (Note 4)	15/15 (Note 4)	64	12/15 (Note 4)	24/15	1.0	0.0
3	15/15	8/15	64	15/8	30/15	1.5	0.5
4	15/15	4/15	64	15/4	30/15	1.5	0.5

Note 1:  $\Delta_{ACK}, \Delta_{NACK}$  and  $\Delta_{CQI} = 30/15$  with  $\beta_{HS} = 30/15 * \beta_c$ .

Note 2: For the HS-DPCCH power mask requirement test in clause 5.2C, 5.7A, and the Error Vector Magnitude (EVM) with HS-DPCCH test in clause 5.13.1A, and HSDPA EVM with phase discontinuity in clause 5.13.1AA,  $\Delta_{ACK}$  and  $\Delta_{NACK} = 30/15$  with  $\beta_{HS} = 30/15 * \beta_c$ , and  $\Delta_{CQI} = 24/15$  with  $\beta_{HS} = 24/15 * \beta_c$ .

Note 3: CM = 1 for  $\beta_c/\beta_d = 12/15, \beta_{HS}/\beta_c = 24/15$ . For all other combinations of DPDCCH, DPCCH and HS-DPCCH the MPR is based on the relative CM difference. This is applicable for only UEs that support HSDPA in release 6 and later releases.

Note 4: For subtest 2 the  $\beta_c/\beta_d$  ratio of 12/15 for the TFC during the measurement period (TF1, TF0) is achieved by setting the signalled gain factors for the reference TFC (TF1, TF1) to  $\beta_c = 11/15$  and  $\beta_d = 15/15$ .

**Setup Configuration**

**HSUPA Setup Configuration:**

- a. The EUT was connected to Base Station Agilent E5515C referred to the Setup Configuration.
- b. The RF path losses were compensated into the measurements.
- c. A call was established between EUT and Base Station with following setting \* :
  - i. Call Configs = 5.2B, 5.9B, 5.10B, and 5.13.2B with QPSK
  - ii. Set the Gain Factors ( $\beta_c$  and  $\beta_d$ ) and parameters (AG Index) were set according to each specific sub-test in the following table, C11.1.3, quoted from the TS 34.121
  - iii. Set Cell Power = -86 dBm
  - iv. Set Channel Type = 12.2k + HSPA
  - v. Set UE Target Power
  - vi. Power Ctrl Mode= Alternating bits
  - vii. Set and observe the E-TFCl
  - viii. Confirm that E-TFCl is equal to the target E-TFCl of 75 for sub-test 1, and other subtest's E-TFCl
- d. The transmitted maximum output power was recorded.

**Table C.11.1.3:  $\beta$  values for transmitter characteristics tests with HS-DPCCH and E-DCH**

Sub-test	$\beta_c$	$\beta_d$	$\beta_d$ (SF)	$\beta_c/\beta_d$	$\beta_{HS}$ (Note 1)	$\beta_{ec}$	$\beta_{ed}$ (Note 5) (Note 6)	$\beta_{ed}$ (SF)	$\beta_{ed}$ (Codes)	CM (dB) (Note 2)	MPR (dB) (Note 2)	AG Index (Note 6)	E-TFCl
1	11/15 (Note 3)	15/15 (Note 3)	64	11/15 (Note 3)	22/15	209/25	1309/225	4	1	1.0	0.0	20	75
2	6/15	15/15	64	6/15	12/15	12/15	94/75	4	1	3.0	2.0	12	67
3	15/15	9/15	64	15/9	30/15	30/15	$\beta_{ed1}: 47/15$ $\beta_{ed2}: 47/15$	4 4	2	2.0	1.0	15	92
4	2/15	15/15	64	2/15	4/15	2/15	56/75	4	1	3.0	2.0	17	71
5	15/15 (Note 4)	15/15 (Note 4)	64	15/15 (Note 4)	30/15	24/15	134/15	4	1	1.0	0.0	21	81

Note 1:  $\Delta_{ACK}, \Delta_{NACK}$  and  $\Delta_{CQI} = 30/15$  with  $\beta_{hs} = 30/15 * \beta_c$ .

Note 2: CM = 1 for  $\beta_c/\beta_d = 12/15$ ,  $\beta_{hs}/\beta_c = 24/15$ . For all other combinations of DPDCH, DPCCH, HS- DPCCH, E-DPDCH and E-DPCCH the MPR is based on the relative CM difference.

Note 3: For subtest 1 the  $\beta_c/\beta_d$  ratio of 11/15 for the TFC during the measurement period (TF1, TF0) is achieved by setting the signalled gain factors for the reference TFC (TF1, TF1) to  $\beta_c = 10/15$  and  $\beta_d = 15/15$ .

Note 4: For subtest 5 the  $\beta_c/\beta_d$  ratio of 15/15 for the TFC during the measurement period (TF1, TF0) is achieved by setting the signalled gain factors for the reference TFC (TF1, TF1) to  $\beta_c = 14/15$  and  $\beta_d = 15/15$ .

Note 5: In case of testing by UE using E-DPDCH Physical Layer category 1, Sub-test 3 is omitted according to TS25.306 Table 5.1g.

Note 6:  $\beta_{ed}$  can not be set directly, it is set by Absolute Grant Value.

**Setup Configuration**

**DC-HSDPA 3GPP release 8 Setup Configuration:**

- a. The EUT was connected to Base Station Agilent E5515C referred to the Setup Configuration below
- b. The RF path losses were compensated into the measurements.
- c. A call was established between EUT and Base Station with following setting:
  - i. Set RMC 12.2Kbps + HSDPA mode.
  - ii. Set Cell Power = -25 dBm
  - iii. Set HS-DSCH Configuration Type to FRC (H-set 12, QPSK)
  - iv. Select HSDPA Uplink Parameters
  - v. Set Gain Factors ( $\beta_c$  and  $\beta_d$ ) and parameters were set according to each Specific sub-test in the following table, C10.1.4, quoted from the TS 34.121
    - a). Subtest 1:  $\beta_c/\beta_d=2/15$
    - b). Subtest 2:  $\beta_c/\beta_d=12/15$
    - c). Subtest 3:  $\beta_c/\beta_d=15/8$
    - d). Subtest 4:  $\beta_c/\beta_d=15/4$
  - vi. Set Delta ACK, Delta NACK and Delta CQI = 8
  - vii. Set Ack-Nack Repetition Factor to 3
  - viii. Set CQI Feedback Cycle (k) to 4 ms
  - ix. Set CQI Repetition Factor to 2
  - x. Power Ctrl Mode = All Up bits
- d. The transmitted maximum output power was recorded.

The following tests were conducted according to the test requirements outlines in 3GPP TS 34.121 specification. A summary of these settings are illustrated below:

**C.8.1.12 Fixed Reference Channel Definition H-Set 12**

**Table C.8.1.12: Fixed Reference Channel H-Set 12**

Parameter	Unit	Value
Nominal Avg. Inf. Bit Rate	kbps	60
Inter-TTI Distance	TTI's	1
Number of HARQ Processes	Processes	6
Information Bit Payload ( $N_{INF}$ )	Bits	120
Number Code Blocks	Blocks	1
Binary Channel Bits Per TTI	Bits	960
Total Available SML's in UE	SML's	19200
Number of SML's per HARQ Proc.	SML's	3200
Coding Rate		0.15
Number of Physical Channel Codes	Codes	1
Modulation		QPSK
Note 1: The RMC is intended to be used for DC-HSDPA mode and both cells shall transmit with identical parameters as listed in the table. Note 2: Maximum number of transmission is limited to 1, i.e., retransmission is not allowed. The redundancy and constellation version 0 shall be used.		

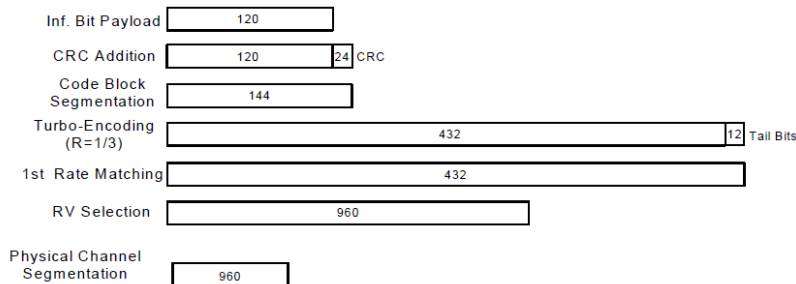

**Figure C.8.19: Coding rate for Fixed reference Channel H-Set 12 (QPSK)**

**Setup Configuration**



<WCDMA Conducted Power>

General Note:

1. Per KDB 941225 D01v03r01, for SAR testing is measured using a 12.2 kbps RMC with TPC bits configured to all "1's".
2. Per KDB 941225 D01v03r01, RMC 12.2kbps setting is used to evaluate SAR. If the maximum output power and tune-up tolerance specified for production units in HSDPA / HSUPA / DC-HSDPA is  $\leq \frac{1}{4}$  dB higher than RMC 12.2Kbps or when the highest reported SAR of the RMC12.2Kbps is scaled by the ratio of specified maximum output power and tune-up tolerance of HSDPA / HSUPA / DC-HSDPA to RMC12.2Kbps and the adjusted SAR is  $\leq 1.2$  W/kg, SAR measurement is not required for HSDPA / HSUPA / DC-HSDPA.

Maximum Average RF Power (Proximity Sensor Inactive)

Band		WCDMA Band II			Tune-up Limit (dBm)	WCDMA Band IV			Tune-up Limit (dBm)	WCDMA Band V			Tune-up Limit (dBm)
Tx Channel		9262	9400	9538		1312	1413	1513		4132	4182	4233	
Rx Channel		9662	9800	9938		1537	1638	1738		4357	4407	4458	
Frequency (MHz)		1852.4	1880	1907.6		1712.4	1732.6	1752.6		826.4	836.4	846.6	
3GPP Rel 99	RMC 12.2Kbps	23.24	23.28	23.22	23.50	22.89	23.19	22.97	23.50	23.17	23.35	23.33	23.50
3GPP Rel 6	HSDPA Subtest-1	22.23	22.35	22.35	22.50	21.99	22.21	22.16	22.50	22.53	22.43	22.45	23.00
3GPP Rel 6	HSDPA Subtest-2	22.33	22.43	22.21	22.50	22.04	22.23	22.22	22.50	22.47	22.36	22.41	23.00
3GPP Rel 6	HSDPA Subtest-3	21.81	21.93	21.98	22.00	21.52	21.72	21.72	22.00	21.98	21.86	21.91	22.50
3GPP Rel 6	HSDPA Subtest-4	21.81	21.93	21.93	22.00	21.51	21.72	21.72	22.00	21.97	21.94	21.90	22.50
3GPP Rel 8	DC-HSDPA Subtest-1	22.21	22.32	22.34	22.50	21.98	22.18	22.15	22.50	22.48	22.46	22.44	23.00
3GPP Rel 8	DC-HSDPA Subtest-2	22.28	22.41	22.22	22.50	22.01	22.18	22.14	22.50	22.49	22.32	22.43	23.00
3GPP Rel 8	DC-HSDPA Subtest-3	21.78	21.89	21.91	22.00	21.43	21.68	21.65	22.00	21.89	21.83	21.96	22.50
3GPP Rel 8	DC-HSDPA Subtest-4	21.82	21.87	21.93	22.00	21.42	21.67	21.58	22.00	21.95	21.88	21.98	22.50
3GPP Rel 6	HSUPA Subtest-1	22.34	22.50	22.40	23.00	22.16	22.35	22.25	23.00	22.55	22.39	22.61	23.00
3GPP Rel 6	HSUPA Subtest-2	20.33	20.56	20.53	21.00	20.15	20.34	20.25	21.00	20.47	20.45	20.56	21.00
3GPP Rel 6	HSUPA Subtest-3	21.35	21.50	21.52	22.00	21.16	21.36	21.26	22.00	21.43	21.39	21.53	22.00
3GPP Rel 6	HSUPA Subtest-4	20.42	20.53	20.53	21.00	20.14	20.34	20.23	21.00	20.47	20.36	20.63	21.00
3GPP Rel 6	HSUPA Subtest-5	22.40	22.50	22.40	23.00	22.20	22.30	22.30	23.00	22.40	22.40	22.60	23.00

Reduced Average RF Power (Proximity Sensor active)

Band		WCDMA Band II			Tune-up Limit (dBm)	WCDMA Band IV			Tune-up Limit (dBm)	WCDMA Band V			Tune-up Limit (dBm)
Tx Channel		9262	9400	9538		1312	1413	1513		4132	4182	4233	
Rx Channel		9662	9800	9938		1537	1638	1738		4357	4407	4458	
Frequency (MHz)		1852.4	1880	1907.6		1712.4	1732.6	1752.6		826.4	836.4	846.6	
3GPP Rel 99	RMC 12.2Kbps	13.89	14.03	14.02	14.50	15.03	15.04	14.85	15.50	20.26	20.38	20.23	20.50
3GPP Rel 6	HSDPA Subtest-1	12.91	12.66	13.00	13.50	13.88	13.94	13.78	14.00	19.60	19.53	19.34	20.00
3GPP Rel 6	HSDPA Subtest-2	12.87	12.64	12.95	13.00	13.85	13.92	13.75	14.00	19.57	19.44	19.31	20.00
3GPP Rel 6	HSDPA Subtest-3	12.36	12.14	12.45	13.00	13.35	13.42	13.26	13.50	19.07	18.95	18.79	19.50
3GPP Rel 6	HSDPA Subtest-4	12.35	12.13	12.44	13.00	13.34	13.42	13.25	13.50	19.04	19.04	18.79	19.50
3GPP Rel 8	DC-HSDPA Subtest-1	12.89	12.60	12.98	13.50	13.87	13.98	13.75	14.50	19.58	19.50	19.32	20.00
3GPP Rel 8	DC-HSDPA Subtest-2	12.87	12.53	12.91	13.50	13.84	13.89	13.76	14.50	19.56	19.48	19.30	20.00
3GPP Rel 8	DC-HSDPA Subtest-3	12.34	12.14	12.48	13.00	13.42	13.40	13.26	14.00	19.06	18.88	18.76	19.50
3GPP Rel 8	DC-HSDPA Subtest-4	12.34	12.15	12.45	13.00	13.35	13.42	13.28	14.00	19.01	19.01	18.74	19.50
3GPP Rel 6	HSUPA Subtest-1	12.96	12.73	13.30	14.00	14.29	14.07	14.14	14.50	19.64	19.48	19.49	20.00
3GPP Rel 6	HSUPA Subtest-2	10.90	10.55	11.05	11.50	11.97	11.69	12.04	12.50	17.54	17.55	17.45	18.00
3GPP Rel 6	HSUPA Subtest-3	11.96	11.75	12.16	12.50	13.27	13.08	12.99	13.50	18.53	18.47	18.43	19.00
3GPP Rel 6	HSUPA Subtest-4	10.88	10.54	11.03	11.50	11.94	11.67	12.03	12.50	17.56	17.45	17.51	18.00
3GPP Rel 6	HSUPA Subtest-5	12.89	12.74	13.30	13.50	14.21	14.07	14.13	14.50	19.47	19.50	19.49	20.00



**<LTE Conducted Power>**

**General Note:**

1. Anritsu MT8820C base station simulator was used to setup the connection with EUT; the frequency band, channel bandwidth, RB allocation configuration, modulation type are set in the base station simulator to configure EUT transmitting at maximum power and at different configurations which are requested to be reported to FCC, for conducted power measurement and SAR testing.
2. Per KDB 941225 D05v02r05, when a properly configured base station simulator is used for the SAR and power measurements, spectrum plots for each RB allocation and offset configuration is not required.
3. Per KDB 941225 D05v02r05, start with the largest channel bandwidth and measure SAR for QPSK with 1 RB allocation, using the RB offset and required test channel combination with the highest maximum output power for RB offsets at the upper edge, middle and lower edge of each required test channel.
4. Per KDB 941225 D05v02r05, 50% RB allocation for QPSK SAR testing follows 1RB QPSK allocation procedure.
5. Per KDB 941225 D05v02r05, For QPSK with 100% RB allocation, SAR is not required when the highest maximum output power for 100 % RB allocation is less than the highest maximum output power in 50% and 1 RB allocations and the highest reported SAR for 1 RB and 50% RB allocation are  $\leq 0.8$  W/kg. Otherwise, SAR is measured for the highest output power channel; and if the reported SAR is  $> 1.45$  W/kg, the remaining required test channels must also be tested.
6. Per KDB 941225 D05v02r05, 16QAM output power for each RB allocation configuration is  $>$  not  $\frac{1}{2}$  dB higher than the same configuration in QPSK and the reported SAR for the QPSK configuration is  $\leq 1.45$  W/kg; Per KDB 941225 D05v02r05, 16QAM SAR testing is not required.
7. Per KDB 941225 D05v02r05, Smaller bandwidth output power for each RB allocation configuration is  $>$  not  $\frac{1}{2}$  dB higher than the same configuration in the largest supported bandwidth, and the reported SAR for the largest supported bandwidth is  $\leq 1.45$  W/kg; Per KDB 941225 D05v02r05, smaller bandwidth SAR testing is not required.
8. For LTE B12 / B5 / B4 the maximum bandwidth does not support three non-overlapping channels, per KDB 941225 D05v02r05, when a device supports overlapping channel assignment in a channel bandwidth configuration, the middle channel of the group of overlapping channels should be selected for testing.



Maximum Average RF Power (Proximity Sensor Inactive)

<LTE Band 2>

BW [MHz]	Modulation	RB Size	RB Offset	Power Low Ch. / Freq.	Power Middle Ch. / Freq.	Power High Ch. / Freq.	Tune-up limit (dBm)	MPR (dB)
Channel				18700	18900	19100		
Frequency (MHz)				1860	1880	1900		
20	QPSK	1	0	22.92	22.98	22.99	23.5	0
20	QPSK	1	49	23.17	23.03	23.03		
20	QPSK	1	99	22.76	22.93	22.91		
20	QPSK	50	0	22.01	21.93	21.97	22.5	1
20	QPSK	50	24	21.86	21.91	21.80		
20	QPSK	50	50	21.89	21.87	21.88		
20	QPSK	100	0	22.01	22.00	21.86		
20	16QAM	1	0	21.78	21.77	21.66	22.5	1
20	16QAM	1	49	21.80	21.76	21.71		
20	16QAM	1	99	21.54	21.66	21.75		
20	16QAM	50	0	20.89	20.88	20.88	21.5	2
20	16QAM	50	24	20.79	20.84	20.77		
20	16QAM	50	50	20.80	20.83	20.82		
20	16QAM	100	0	20.90	20.93	20.81		
Channel				18675	18900	19125	Tune-up limit (dBm)	MPR (dB)
Frequency (MHz)				1857.5	1880	1902.5		
15	QPSK	1	0	23.00	23.00	22.99	23.5	0
15	QPSK	1	37	23.03	23.14	23.10		
15	QPSK	1	74	22.90	22.90	22.94		
15	QPSK	36	0	21.99	21.94	21.85	22.5	1
15	QPSK	36	20	21.83	21.98	21.87		
15	QPSK	36	39	21.82	21.84	21.89		
15	QPSK	75	0	21.94	21.93	21.86		
15	16QAM	1	0	21.77	21.76	21.82	22.5	1
15	16QAM	1	37	21.75	21.91	21.95		
15	16QAM	1	74	21.62	21.68	21.68		
15	16QAM	36	0	20.85	20.91	20.81	21.5	2
15	16QAM	36	20	20.78	20.88	20.82		
15	16QAM	36	39	20.83	20.81	20.82		
15	16QAM	75	0	20.88	20.88	20.85		



Channel				18650	18900	19150	Tune-up limit (dBm)	MPR (dB)
Frequency (MHz)				1855	1880	1905		
10	QPSK	1	0	23.04	23.02	23.03	23.5	0
10	QPSK	1	25	23.02	22.97	22.97		
10	QPSK	1	49	22.89	22.95	23.02		
10	QPSK	25	0	21.95	21.94	21.86	22.5	1
10	QPSK	25	12	21.99	21.97	21.89		
10	QPSK	25	25	21.94	21.88	21.88		
10	QPSK	50	0	21.96	22.02	21.90		
10	16QAM	1	0	21.68	21.65	21.80	22.5	1
10	16QAM	1	25	21.96	21.87	21.95		
10	16QAM	1	49	21.80	21.77	21.58		
10	16QAM	25	0	20.87	20.89	20.89	21.5	2
10	16QAM	25	12	20.88	20.90	20.82		
10	16QAM	25	25	20.84	20.78	20.86		
10	16QAM	50	0	20.89	20.91	20.86		
Channel				18625	18900	19175	Tune-up limit (dBm)	MPR (dB)
Frequency (MHz)				1852.5	1880	1907.5		
5	QPSK	1	0	22.81	22.87	22.83	23.5	0
5	QPSK	1	12	23.10	23.11	23.17		
5	QPSK	1	24	22.83	22.79	22.90		
5	QPSK	12	0	21.95	21.91	21.93	22.5	1
5	QPSK	12	7	21.90	21.94	21.89		
5	QPSK	12	13	21.93	21.98	21.94		
5	QPSK	25	0	21.91	22.00	21.95		
5	16QAM	1	0	21.54	21.72	21.70	22.5	1
5	16QAM	1	12	21.77	22.01	21.89		
5	16QAM	1	24	21.64	21.50	21.60		
5	16QAM	12	0	20.82	20.86	20.84	21.5	2
5	16QAM	12	7	20.87	20.87	20.97		
5	16QAM	12	13	20.87	20.74	20.89		
5	16QAM	25	0	20.85	20.85	20.84		



Channel				18615	18900	19185	Tune-up limit (dBm)	MPR (dB)
Frequency (MHz)				1851.5	1880	1908.5		
3	QPSK	1	0	22.87	22.92	22.92	23.5	0
3	QPSK	1	8	22.82	22.87	22.85		
3	QPSK	1	14	22.87	22.78	22.89		
3	QPSK	8	0	21.93	21.93	21.92	22.5	1
3	QPSK	8	4	21.91	21.88	21.91		
3	QPSK	8	7	21.96	21.97	21.90		
3	QPSK	15	0	21.93	21.91	21.86		
3	16QAM	1	0	21.79	21.79	21.84	22.5	1
3	16QAM	1	8	21.75	21.70	21.72		
3	16QAM	1	14	21.83	21.70	21.66		
3	16QAM	8	0	20.75	20.84	20.84	21.5	2
3	16QAM	8	4	20.81	20.85	20.82		
3	16QAM	8	7	20.82	20.89	20.83		
3	16QAM	15	0	20.80	20.87	20.85		
Channel				18607	18900	19193	Tune-up limit (dBm)	MPR (dB)
Frequency (MHz)				1850.7	1880	1909.3		
1.4	QPSK	1	0	22.95	22.92	22.91	23.5	0
1.4	QPSK	1	3	22.69	23.01	22.95		
1.4	QPSK	1	5	22.81	22.88	22.91		
1.4	QPSK	3	0	22.97	22.94	23.08		
1.4	QPSK	3	1	23.06	23.04	23.11		
1.4	QPSK	3	3	23.03	22.98	22.84		
1.4	QPSK	6	0	21.88	21.95	21.82	22.5	1
1.4	16QAM	1	0	21.62	21.82	21.57	22.5	1
1.4	16QAM	1	3	21.77	21.83	21.55		
1.4	16QAM	1	5	21.64	21.82	21.64		
1.4	16QAM	3	0	22.16	21.95	21.78		
1.4	16QAM	3	1	21.94	22.02	21.71		
1.4	16QAM	3	3	22.19	22.03	22.17		
1.4	16QAM	6	0	20.79	20.74	20.54	21.5	2



<LTE Band 4>

BW [MHz]	Modulation	RB Size	RB Offset	Power Low Ch. / Freq.	Power Middle Ch. / Freq.	Power High Ch. / Freq.	Tune-up limit (dBm)	MPR (dB)
Channel				20050	20175	20300		
Frequency (MHz)				1720	1732.5	1745		
20	QPSK	1	0	22.63	22.72	22.92	23.5	0
20	QPSK	1	49	23.19	23.32	23.17		
20	QPSK	1	99	22.81	22.66	22.97		
20	QPSK	50	0	22.00	21.98	22.26	22.5	1
20	QPSK	50	24	21.97	21.90	22.19		
20	QPSK	50	50	21.96	21.93	22.16		
20	QPSK	100	0	21.94	22.21	21.97	22.5	1
20	16QAM	1	0	21.76	21.84	22.02		
20	16QAM	1	49	21.81	21.69	21.93		
20	16QAM	1	99	21.70	21.82	21.86	21.5	2
20	16QAM	50	0	21.08	20.82	21.21		
20	16QAM	50	24	21.01	20.84	21.12		
20	16QAM	50	50	20.99	20.86	21.18	21.5	2
20	16QAM	100	0	20.88	20.97	21.18		
Channel				20025	20175	20325		
Frequency (MHz)				1717.5	1732.5	1747.5		
15	QPSK	1	0	22.97	22.65	23.09	23.5	0
15	QPSK	1	37	23.14	22.84	23.30		
15	QPSK	1	74	22.80	22.89	23.09		
15	QPSK	36	0	21.99	21.99	22.28	22.5	1
15	QPSK	36	20	22.03	21.95	22.21		
15	QPSK	36	39	21.97	21.95	22.12		
15	QPSK	75	0	21.97	21.96	22.19	22.5	1
15	16QAM	1	0	21.74	21.79	22.10		
15	16QAM	1	37	21.77	21.69	21.67		
15	16QAM	1	74	21.71	21.80	21.88	21.5	2
15	16QAM	36	0	21.11	20.91	21.14		
15	16QAM	36	20	20.87	20.89	21.14		
15	16QAM	36	39	20.86	20.90	21.08	21.5	2
15	16QAM	75	0	21.00	20.89	21.14		



Channel				20000	20175	20350	Tune-up limit (dBm)	MPR (dB)
Frequency (MHz)				1715	1732.5	1750		
10	QPSK	1	0	22.84	22.84	22.71	23.5	0
10	QPSK	1	25	23.06	22.85	22.62		
10	QPSK	1	49	22.80	22.63	22.86		
10	QPSK	25	0	22.04	21.93	21.92	22.5	1
10	QPSK	25	12	21.96	21.96	21.77		
10	QPSK	25	25	21.98	21.96	21.80		
10	QPSK	50	0	22.00	21.97	21.79	22.5	1
10	16QAM	1	0	21.78	21.77	21.76		
10	16QAM	1	25	21.71	21.61	21.48		
10	16QAM	1	49	21.74	21.61	21.53	21.5	2
10	16QAM	25	0	20.88	20.87	21.09		
10	16QAM	25	12	20.91	20.80	20.93		
10	16QAM	25	25	20.89	20.89	20.96	21.5	2
10	16QAM	50	0	20.87	20.87	20.76		
Channel				19975	20175	20375	Tune-up limit (dBm)	MPR (dB)
Frequency (MHz)				1712.5	1732.5	1752.5		
5	QPSK	1	0	22.64	22.59	22.60	23.5	0
5	QPSK	1	12	22.72	22.66	22.72		
5	QPSK	1	24	22.67	22.65	22.77		
5	QPSK	12	0	21.96	21.97	21.89	22.5	1
5	QPSK	12	7	22.02	22.01	21.92		
5	QPSK	12	13	21.85	21.93	21.96		
5	QPSK	25	0	21.91	21.91	21.92	22.5	1
5	16QAM	1	0	21.70	21.96	21.70		
5	16QAM	1	12	21.49	21.67	22.02		
5	16QAM	1	24	21.42	21.66	21.59	21.5	2
5	16QAM	12	0	20.72	20.91	20.90		
5	16QAM	12	7	20.87	20.89	20.63		
5	16QAM	12	13	20.90	20.88	20.86	21.5	2
5	16QAM	25	0	20.94	21.13	20.72		



Channel				19965	20175	20385	Tune-up limit (dBm)	MPR (dB)
Frequency (MHz)				1711.5	1732.5	1753.5		
3	QPSK	1	0	22.88	22.73	22.73	23.5	0
3	QPSK	1	8	22.58	22.52	22.49		
3	QPSK	1	14	22.81	22.78	22.74		
3	QPSK	8	0	21.96	21.95	21.90	22.5	1
3	QPSK	8	4	21.93	21.95	21.92		
3	QPSK	8	7	21.94	21.98	21.99		
3	QPSK	15	0	21.99	21.97	21.85	22.5	1
3	16QAM	1	0	21.54	21.54	21.42		
3	16QAM	1	8	21.72	21.54	21.53		
3	16QAM	1	14	21.79	21.58	21.47	21.5	2
3	16QAM	8	0	20.96	20.59	20.88		
3	16QAM	8	4	20.69	20.63	20.91		
3	16QAM	8	7	20.87	20.69	20.97	21.5	2
3	16QAM	15	0	20.85	20.90	20.79		
Channel				19957	20175	20393	Tune-up limit (dBm)	MPR (dB)
Frequency (MHz)				1710.7	1732.5	1754.3		
1.4	QPSK	1	0	22.93	22.88	22.88	23.5	0
1.4	QPSK	1	3	23.03	22.95	22.95		
1.4	QPSK	1	5	22.81	22.89	22.81		
1.4	QPSK	3	0	22.79	22.93	22.90		
1.4	QPSK	3	1	22.86	23.14	23.07		
1.4	QPSK	3	3	22.92	22.84	22.77	22.5	1
1.4	QPSK	6	0	21.92	21.91	21.79		
1.4	16QAM	1	0	21.39	21.73	21.71	22.5	1
1.4	16QAM	1	3	21.54	21.68	21.64		
1.4	16QAM	1	5	21.70	21.69	21.68		
1.4	16QAM	3	0	21.82	21.93	21.78		
1.4	16QAM	3	1	21.95	21.87	21.69		
1.4	16QAM	3	3	21.83	21.98	21.82	21.5	2
1.4	16QAM	6	0	20.78	20.69	20.62		



<LTE Band 5>

BW [MHz]	Modulation	RB Size	RB Offset	Power Low Ch. / Freq.	Power Middle Ch. / Freq.	Power High Ch. / Freq.	Tune-up limit (dBm)	MPR (dB)
Channel				20450	20525	20600		
Frequency (MHz)				829	836.5	844		
10	QPSK	1	0	23.09	23.17	23.31	23.5	0
10	QPSK	1	25	23.08	22.87	23.07		
10	QPSK	1	49	22.96	22.81	22.98		
10	QPSK	25	0	22.09	22.12	22.10	22.5	1
10	QPSK	25	12	22.02	22.01	22.07		
10	QPSK	25	25	22.05	22.00	22.09		
10	QPSK	50	0	22.11	21.89	22.20	22.5	1
10	16QAM	1	0	22.00	21.91	21.99		
10	16QAM	1	25	22.00	21.92	21.88		
10	16QAM	1	49	21.89	21.55	22.00	21.5	2
10	16QAM	25	0	21.12	20.94	21.20		
10	16QAM	25	12	20.80	21.05	20.92		
10	16QAM	25	25	20.80	21.18	21.24	21.5	2
10	16QAM	25	25	20.80	21.18	21.24		
10	16QAM	50	0	20.97	20.90	21.13		
Channel				20425	20525	20625		
Frequency (MHz)				826.5	836.5	846.5		
5	QPSK	1	0	23.15	22.89	22.74	23.5	0
5	QPSK	1	12	23.15	22.99	23.15		
5	QPSK	1	24	23.16	22.77	22.87		
5	QPSK	12	0	22.21	22.04	22.21	22.5	1
5	QPSK	12	7	22.27	22.00	22.26		
5	QPSK	12	13	22.14	22.05	22.25		
5	QPSK	25	0	21.97	21.78	22.24	22.5	1
5	16QAM	1	0	21.99	21.61	21.79		
5	16QAM	1	12	21.99	21.87	22.31		
5	16QAM	1	24	21.77	21.70	21.93	21.5	2
5	16QAM	12	0	20.82	20.74	21.22		
5	16QAM	12	7	20.91	20.80	21.18		
5	16QAM	12	13	21.04	20.87	21.26	21.5	2
5	16QAM	12	13	21.04	20.87	21.26		
5	16QAM	25	0	20.89	20.83	21.26		



Channel				20415	20525	20635	Tune-up limit (dBm)	MPR (dB)
Frequency (MHz)				825.5	836.5	847.5		
3	QPSK	1	0	23.11	23.09	23.14	23.5	0
3	QPSK	1	8	23.20	22.84	23.13		
3	QPSK	1	14	23.20	22.85	23.21		
3	QPSK	8	0	22.28	22.02	22.30	22.5	1
3	QPSK	8	4	22.19	22.07	22.24		
3	QPSK	8	7	22.24	22.08	22.31		
3	QPSK	15	0	22.21	22.01	22.24		
3	16QAM	1	0	22.09	21.92	22.13	22.5	1
3	16QAM	1	8	21.99	21.87	21.93		
3	16QAM	1	14	22.15	21.68	22.08		
3	16QAM	8	0	20.76	20.71	21.06	21.5	2
3	16QAM	8	4	20.84	20.68	21.39		
3	16QAM	8	7	21.17	20.99	21.16		
3	16QAM	15	0	21.00	21.08	21.09		
Channel				20407	20525	20643	Tune-up limit (dBm)	MPR (dB)
Frequency (MHz)				824.7	836.5	848.3		
1.4	QPSK	1	0	23.06	22.88	23.21	23.5	0
1.4	QPSK	1	3	23.28	22.86	23.24		
1.4	QPSK	1	5	23.17	22.82	23.14		
1.4	QPSK	3	0	23.14	22.99	23.26		
1.4	QPSK	3	1	23.23	23.07	23.30		
1.4	QPSK	3	3	23.24	23.07	23.29		
1.4	QPSK	6	0	22.22	22.01	22.17	22.5	1
1.4	16QAM	1	0	22.03	21.90	22.03	22.5	1
1.4	16QAM	1	3	22.36	21.79	22.03		
1.4	16QAM	1	5	22.34	21.89	22.02		
1.4	16QAM	3	0	22.46	21.67	22.03		
1.4	16QAM	3	1	22.48	22.01	22.34		
1.4	16QAM	3	3	22.45	22.06	22.39		
1.4	16QAM	6	0	20.99	20.75	21.10	21.5	2



<LTE Band 7>

BW [MHz]	Modulation	RB Size	RB Offset	Power Low Ch. / Freq.	Power Middle Ch. / Freq.	Power High Ch. / Freq.	Tune-up limit (dBm)	MPR (dB)
Channel				20850	21100	21350		
Frequency (MHz)				2510	2535	2560		
20	QPSK	1	0	22.77	22.61	22.95	23.5	0
20	QPSK	1	49	22.92	23.23	23.04		
20	QPSK	1	99	22.66	23.07	22.78		
20	QPSK	50	0	22.04	22.16	22.14	22.5	1
20	QPSK	50	24	22.01	22.08	22.13		
20	QPSK	50	50	22.00	22.00	22.12		
20	QPSK	100	0	22.09	22.17	22.06	22.5	1
20	16QAM	1	0	21.83	21.93	21.38		
20	16QAM	1	49	21.75	21.73	21.90		
20	16QAM	1	99	21.67	22.00	21.95	21.5	2
20	16QAM	50	0	20.91	21.08	21.14		
20	16QAM	50	24	20.94	21.02	21.09		
20	16QAM	50	50	21.00	21.07	21.15	21.5	2
20	16QAM	100	0	20.99	21.14	21.18		
Channel				20825	21100	21375		
Frequency (MHz)				2507.5	2535	2562.5		
15	QPSK	1	0	22.84	22.91	23.10	23.5	0
15	QPSK	1	37	22.98	23.18	23.17		
15	QPSK	1	74	23.02	23.09	23.06		
15	QPSK	36	0	22.12	22.14	22.15	22.5	1
15	QPSK	36	20	22.04	22.09	22.17		
15	QPSK	36	39	22.09	22.05	22.16		
15	QPSK	75	0	22.08	22.04	22.13	22.5	1
15	16QAM	1	0	22.23	21.95	21.99		
15	16QAM	1	37	22.27	22.00	22.50		
15	16QAM	1	74	22.25	22.01	22.10	21.5	2
15	16QAM	36	0	21.18	21.06	21.17		
15	16QAM	36	20	21.15	21.11	21.09		
15	16QAM	36	39	21.11	21.07	21.30	21.5	2
15	16QAM	75	0	21.10	21.15	21.27		



Channel				20800	21100	21400	Tune-up limit (dBm)	MPR (dB)
Frequency (MHz)				2505	2535	2565		
10	QPSK	1	0	22.75	22.95	23.16	23.5	0
10	QPSK	1	25	22.94	22.82	22.85		
10	QPSK	1	49	22.79	22.95	22.71		
10	QPSK	25	0	22.00	22.09	22.15	22.5	1
10	QPSK	25	12	22.07	22.06	22.13		
10	QPSK	25	25	22.05	22.09	22.12		
10	QPSK	50	0	22.06	22.08	22.06		
10	16QAM	1	0	21.84	21.86	21.97	22.5	1
10	16QAM	1	25	21.85	21.83	21.88		
10	16QAM	1	49	21.78	21.94	21.94		
10	16QAM	25	0	21.04	20.96	21.19	21.5	2
10	16QAM	25	12	21.18	21.02	21.17		
10	16QAM	25	25	21.08	21.20	21.16		
10	16QAM	50	0	21.09	21.10	21.08		
Channel				20775	21100	21425	Tune-up limit (dBm)	MPR (dB)
Frequency (MHz)				2502.5	2535	2567.5		
5	QPSK	1	0	22.74	22.83	22.83	23.5	0
5	QPSK	1	12	22.96	23.11	23.18		
5	QPSK	1	24	22.82	22.81	22.68		
5	QPSK	12	0	22.03	22.12	22.08	22.5	1
5	QPSK	12	7	22.05	22.15	22.14		
5	QPSK	12	13	21.97	22.09	22.07		
5	QPSK	25	0	21.98	22.03	22.12		
5	16QAM	1	0	21.80	21.84	21.85	22.5	1
5	16QAM	1	12	21.68	22.02	21.78		
5	16QAM	1	24	21.88	21.77	21.55		
5	16QAM	12	0	20.87	20.96	20.94	21.5	2
5	16QAM	12	7	20.88	21.01	21.00		
5	16QAM	12	13	20.90	21.00	20.99		
5	16QAM	25	0	20.91	21.16	21.19		



<LTE Band 12>

BW [MHz]	Modulation	RB Size	RB Offset	Power Low Ch. / Freq.	Power Middle Ch. / Freq.	Power High Ch. / Freq.	Tune-up limit (dBm)	MPR (dB)
Channel				23060	23095	23130		
Frequency (MHz)				704	707.5	711		
10	QPSK	1	0	22.66	22.62	22.85	23.5	0
10	QPSK	1	25	23.15	22.83	22.90		
10	QPSK	1	49	22.71	22.80	22.72		
10	QPSK	25	0	21.93	21.99	22.04	22.5	1
10	QPSK	25	12	21.88	21.95	22.01		
10	QPSK	25	25	21.86	21.85	21.96		
10	QPSK	50	0	21.99	21.96	21.98	22.5	1
10	16QAM	1	0	21.43	21.50	21.72		
10	16QAM	1	25	21.66	21.87	21.76		
10	16QAM	1	49	21.76	21.66	21.80	21.5	2
10	16QAM	25	0	20.81	20.88	21.08		
10	16QAM	25	12	20.87	21.00	21.02		
10	16QAM	25	25	21.06	21.03	21.19	21.5	2
10	16QAM	25	25	21.06	21.03	21.19		
10	16QAM	50	0	20.67	21.06	20.92		
Channel				23035	23095	23155		
Frequency (MHz)				701.5	707.5	713.5		
5	QPSK	1	0	22.51	22.45	22.50	23.5	0
5	QPSK	1	12	22.88	23.14	22.99		
5	QPSK	1	24	22.67	22.79	22.56		
5	QPSK	12	0	21.79	21.92	21.98	22.5	1
5	QPSK	12	7	21.86	22.02	21.97		
5	QPSK	12	13	21.87	22.04	21.90		
5	QPSK	25	0	21.81	22.04	21.90	22.5	1
5	16QAM	1	0	21.34	21.70	21.72		
5	16QAM	1	12	21.35	21.83	21.59		
5	16QAM	1	24	21.29	21.54	21.62	21.5	2
5	16QAM	12	0	20.58	20.72	20.83		
5	16QAM	12	7	21.05	20.86	20.76		
5	16QAM	12	13	20.86	20.94	20.90	21.5	2
5	16QAM	12	13	20.86	20.94	20.90		
5	16QAM	25	0	20.92	21.05	20.89		



Channel				23025	23095	23165	Tune-up limit (dBm)	MPR (dB)
Frequency (MHz)				700.5	707.5	714.5		
3	QPSK	1	0	22.54	22.73	23.02	23.5	0
3	QPSK	1	8	22.52	22.67	22.78		
3	QPSK	1	14	22.59	22.57	23.06		
3	QPSK	8	0	21.77	22.05	22.04	22.5	1
3	QPSK	8	4	21.96	22.03	21.92		
3	QPSK	8	7	21.96	22.01	22.01		
3	QPSK	15	0	21.89	22.02	21.97	22.5	1
3	16QAM	1	0	21.87	22.26	21.76		
3	16QAM	1	8	21.96	21.76	21.61		
3	16QAM	1	14	21.58	21.68	21.74	21.5	2
3	16QAM	8	0	20.82	21.10	21.07		
3	16QAM	8	4	21.00	20.79	21.06		
3	16QAM	8	7	21.11	20.75	21.13	21.5	2
3	16QAM	15	0	20.95	20.70	20.98		
Channel				23017	23095	23173	Tune-up limit (dBm)	MPR (dB)
Frequency (MHz)				699.7	707.5	715.3		
1.4	QPSK	1	0	22.71	22.90	22.76	23.5	0
1.4	QPSK	1	3	22.78	23.02	22.95		
1.4	QPSK	1	5	22.68	22.91	22.83		
1.4	QPSK	3	0	22.86	22.98	22.98		
1.4	QPSK	3	1	22.95	23.01	23.01		
1.4	QPSK	3	3	22.78	23.04	22.90	22.5	1
1.4	QPSK	6	0	21.82	22.05	21.90		
1.4	16QAM	1	0	21.69	21.84	21.76	22.5	1
1.4	16QAM	1	3	21.58	21.79	21.75		
1.4	16QAM	1	5	21.66	21.88	21.82		
1.4	16QAM	3	0	21.71	21.90	21.86		
1.4	16QAM	3	1	21.79	22.03	21.89		
1.4	16QAM	3	3	21.63	21.70	22.00	21.5	2
1.4	16QAM	6	0	20.63	20.81	20.80		



<LTE Band 30>

BW [MHz]	Modulation	RB Size	RB Offset	Power Low Ch. / Freq.	Power Middle Ch. / Freq.	Power High Ch. / Freq.	Tune-up limit (dBm)	MPR (dB)
Channel				27710				
Frequency (MHz)				2310				
10	QPSK	1	0		23.56		24	0
10	QPSK	1	25		23.67			
10	QPSK	1	49		23.45			
10	QPSK	25	0		22.68		23	1
10	QPSK	25	12		22.63			
10	QPSK	25	25		22.65			
10	QPSK	50	0		22.61		23	1
10	16QAM	1	0		22.96			
10	16QAM	1	25		22.55			
10	16QAM	1	49		22.65		22	2
10	16QAM	25	0		21.57			
10	16QAM	25	12		21.58			
10	16QAM	25	25		21.58		22	2
10	16QAM	25	25		21.58			
10	16QAM	50	0		21.56			
Channel				27685	27710	27735	Tune-up limit (dBm)	MPR (dB)
Frequency (MHz)				2307.5	2310	2312.5		
5	QPSK	1	0	23.42	23.43	23.45	24	0
5	QPSK	1	12	23.59	23.63	23.66		
5	QPSK	1	24	23.22	23.39	23.64		
5	QPSK	12	0	22.64	22.59	22.64	23	1
5	QPSK	12	7	22.64	22.69	22.67		
5	QPSK	12	13	22.54	22.63	22.65		
5	QPSK	25	0	22.56	22.62	22.66	23	1
5	16QAM	1	0	22.53	22.33	22.34		
5	16QAM	1	12	22.30	22.52	22.29		
5	16QAM	1	24	22.30	22.06	22.34	22	2
5	16QAM	12	0	21.53	21.32	21.57		
5	16QAM	12	7	21.34	21.41	21.57		
5	16QAM	12	13	21.47	21.54	21.55	22	2
5	16QAM	12	13	21.47	21.54	21.55		
5	16QAM	25	0	21.46	21.38	21.39		



Reduced Average RF Power (Proximity Sensor active)

<LTE Band 2>

BW [MHz]	Modulation	RB Size	RB Offset	Power Low Ch. / Freq.	Power Middle Ch. / Freq.	Power High Ch. / Freq.	Tune-up limit (dBm)	MPR (dB)
Channel				18700	18900	19100		
Frequency (MHz)				1860	1880	1900		
20	QPSK	1	0	13.41	13.50	12.59	14	0
20	QPSK	1	49	13.80	13.65	13.59		
20	QPSK	1	99	13.38	13.57	12.44		
20	QPSK	50	0	13.74	13.62	13.45	14	0
20	QPSK	50	24	13.64	13.61	13.41		
20	QPSK	50	50	13.59	13.60	13.20		
20	QPSK	100	0	13.70	13.68	13.21	14	0
20	16QAM	1	0	13.37	13.43	13.00		
20	16QAM	1	49	13.10	13.37	13.77		
20	16QAM	1	99	12.96	12.98	12.87	14	0
20	16QAM	50	0	13.86	13.63	13.30		
20	16QAM	50	24	13.64	13.69	13.48		
20	16QAM	50	50	13.70	13.54	13.29	14	0
20	16QAM	100	0	13.66	13.62	13.30		
Channel				18675	18900	19125		
Frequency (MHz)				1857.5	1880	1902.5		
15	QPSK	1	0	13.70	13.45	13.55	14	0
15	QPSK	1	37	13.72	13.81	13.32		
15	QPSK	1	74	13.63	13.58	12.41		
15	QPSK	36	0	13.70	13.62	13.30	14	0
15	QPSK	36	20	13.57	13.59	13.32		
15	QPSK	36	39	13.56	13.51	13.15		
15	QPSK	75	0	13.72	13.75	13.19	14	0
15	16QAM	1	0	13.66	13.49	13.54		
15	16QAM	1	37	13.44	13.39	13.87		
15	16QAM	1	74	13.49	13.65	12.98	14	0
15	16QAM	36	0	13.62	13.62	13.35		
15	16QAM	36	20	13.62	13.66	13.37		
15	16QAM	36	39	13.64	13.61	13.23	14	0
15	16QAM	75	0	13.70	13.81	13.26		



Channel				18650	18900	19150	Tune-up limit (dBm)	MPR (dB)
Frequency (MHz)				1855	1880	1905		
10	QPSK	1	0	13.73	13.40	13.39	14	0
10	QPSK	1	25	13.63	13.50	13.33		
10	QPSK	1	49	13.54	13.40	12.63		
10	QPSK	25	0	13.64	13.61	13.48	14	0
10	QPSK	25	12	13.65	13.58	13.23		
10	QPSK	25	25	13.61	13.50	13.22		
10	QPSK	50	0	13.62	13.62	13.22		
10	16QAM	1	0	13.76	13.69	13.55	14	0
10	16QAM	1	25	13.59	13.35	13.46		
10	16QAM	1	49	13.25	13.00	12.81		
10	16QAM	25	0	13.91	13.55	13.62	14	0
10	16QAM	25	12	13.80	13.57	13.34		
10	16QAM	25	25	13.78	13.45	13.31		
10	16QAM	50	0	13.80	13.51	13.35		
Channel				18625	18900	19175	Tune-up limit (dBm)	MPR (dB)
Frequency (MHz)				1852.5	1880	1907.5		
5	QPSK	1	0	13.40	13.22	13.42	14	0
5	QPSK	1	12	13.55	13.76	13.60		
5	QPSK	1	24	13.42	13.34	13.18		
5	QPSK	12	0	13.54	13.64	13.55	14	0
5	QPSK	12	7	13.57	13.61	13.54		
5	QPSK	12	13	13.66	13.67	13.49		
5	QPSK	25	0	13.59	13.61	13.56		
5	16QAM	1	0	13.05	13.04	13.35	14	0
5	16QAM	1	12	13.08	13.18	13.05		
5	16QAM	1	24	12.97	12.97	12.54		
5	16QAM	12	0	13.48	13.43	13.40	14	0
5	16QAM	12	7	13.69	13.51	13.14		
5	16QAM	12	13	13.64	13.59	12.96		
5	16QAM	25	0	13.80	13.53	13.19		



Channel				18615	18900	19185	Tune-up limit (dBm)	MPR (dB)
Frequency (MHz)				1851.5	1880	1908.5		
3	QPSK	1	0	13.48	13.54	13.50	14	0
3	QPSK	1	8	13.48	13.47	13.33		
3	QPSK	1	14	13.51	13.44	13.39		
3	QPSK	8	0	13.75	13.59	13.60	14	0
3	QPSK	8	4	13.68	13.63	13.61		
3	QPSK	8	7	13.81	13.54	13.54		
3	QPSK	15	0	13.58	13.53	13.65		
3	16QAM	1	0	13.10	13.45	13.43	14	0
3	16QAM	1	8	13.22	13.75	13.01		
3	16QAM	1	14	13.25	13.30	12.99		
3	16QAM	8	0	13.63	13.43	13.09	14	0
3	16QAM	8	4	13.98	13.74	13.02		
3	16QAM	8	7	13.70	13.79	12.86		
3	16QAM	15	0	13.60	13.55	12.84		
Channel				18607	18900	19193	Tune-up limit (dBm)	MPR (dB)
Frequency (MHz)				1850.7	1880	1909.3		
1.4	QPSK	1	0	13.57	13.61	13.45	14	0
1.4	QPSK	1	3	13.77	13.61	13.46		
1.4	QPSK	1	5	13.38	13.56	13.49		
1.4	QPSK	3	0	13.57	13.84	13.56		
1.4	QPSK	3	1	13.61	13.81	13.79		
1.4	QPSK	3	3	13.62	13.63	13.57		
1.4	QPSK	6	0	13.75	13.57	13.52	14	0
1.4	16QAM	1	0	13.86	13.40	13.36	14	0
1.4	16QAM	1	3	13.72	13.36	13.59		
1.4	16QAM	1	5	13.69	13.65	13.45		
1.4	16QAM	3	0	13.69	13.48	13.53		
1.4	16QAM	3	1	13.75	13.77	13.64		
1.4	16QAM	3	3	13.97	13.76	13.69		
1.4	16QAM	6	0	13.75	13.63	13.51	14	0



<LTE Band 4>

BW [MHz]	Modulation	RB Size	RB Offset	Power Low Ch. / Freq.	Power Middle Ch. / Freq.	Power High Ch. / Freq.	Tune-up limit (dBm)	MPR (dB)
Channel				20050	20175	20300		
Frequency (MHz)				1720	1732.5	1745		
20	QPSK	1	0	14.72	14.85	15.25	15.5	0
20	QPSK	1	49	15.24	15.23	15.47		
20	QPSK	1	99	14.92	15.14	15.21		
20	QPSK	50	0	15.18	15.09	15.23	15.5	0
20	QPSK	50	24	15.11	14.97	15.22		
20	QPSK	50	50	15.04	14.96	15.21		
20	QPSK	100	0	15.17	14.97	15.22	15.5	0
20	16QAM	1	0	14.72	15.23	14.91		
20	16QAM	1	49	14.71	14.96	14.87		
20	16QAM	1	99	14.40	14.77	14.81	15.5	0
20	16QAM	50	0	15.10	15.09	15.23		
20	16QAM	50	24	15.21	15.04	15.38		
20	16QAM	50	50	14.92	14.95	15.25	15.5	0
20	16QAM	100	0	15.10	15.00	15.12		
Channel				20025	20175	20325		
Frequency (MHz)				1717.5	1732.5	1747.5		
15	QPSK	1	0	14.94	14.94	15.15	15.5	0
15	QPSK	1	37	15.42	15.18	15.46		
15	QPSK	1	74	14.99	14.99	15.25		
15	QPSK	36	0	15.17	14.97	15.23	15.5	0
15	QPSK	36	20	15.05	14.98	15.28		
15	QPSK	36	39	15.13	14.96	15.27		
15	QPSK	75	0	15.13	14.94	15.22	15.5	0
15	16QAM	1	0	14.87	15.09	15.30		
15	16QAM	1	37	14.83	15.48	15.28		
15	16QAM	1	74	15.15	14.95	15.23	15.5	0
15	16QAM	36	0	15.19	14.96	15.23		
15	16QAM	36	20	15.05	14.96	15.16		
15	16QAM	36	39	15.15	15.07	15.29	15.5	0
15	16QAM	75	0	15.09	15.05	15.22		



Channel				20000	20175	20350	Tune-up limit (dBm)	MPR (dB)
Frequency (MHz)				1715	1732.5	1750		
10	QPSK	1	0	14.89	14.79	15.11	15.5	0
10	QPSK	1	25	14.94	14.78	15.07		
10	QPSK	1	49	15.10	14.80	15.12		
10	QPSK	25	0	15.13	15.01	15.27	15.5	0
10	QPSK	25	12	15.10	15.00	15.29		
10	QPSK	25	25	15.07	14.84	15.18		
10	QPSK	50	0	15.11	15.07	15.27		
10	16QAM	1	0	15.48	15.02	15.32	15.5	0
10	16QAM	1	25	15.12	14.90	15.27		
10	16QAM	1	49	15.08	14.92	15.23		
10	16QAM	25	0	15.13	15.28	15.48	15.5	0
10	16QAM	25	12	15.09	15.24	15.49		
10	16QAM	25	25	15.16	15.33	15.44		
10	16QAM	50	0	15.19	15.14	15.23		
Channel				19975	20175	20375	Tune-up limit (dBm)	MPR (dB)
Frequency (MHz)				1712.5	1732.5	1752.5		
5	QPSK	1	0	14.59	14.71	15.04	15.5	0
5	QPSK	1	12	15.09	14.97	15.11		
5	QPSK	1	24	14.54	14.55	14.93		
5	QPSK	12	0	15.07	14.93	15.19	15.5	0
5	QPSK	12	7	15.17	15.06	15.19		
5	QPSK	12	13	15.11	14.99	15.24		
5	QPSK	25	0	15.01	14.97	15.23		
5	16QAM	1	0	14.55	14.68	14.97	15.5	0
5	16QAM	1	12	14.75	14.63	14.96		
5	16QAM	1	24	14.64	14.63	14.96		
5	16QAM	12	0	15.24	14.99	15.24	15.5	0
5	16QAM	12	7	15.24	15.08	15.04		
5	16QAM	12	13	15.27	15.01	15.12		
5	16QAM	25	0	15.10	15.20	15.36		



Channel				19965	20175	20385	Tune-up limit (dBm)	MPR (dB)
Frequency (MHz)				1711.5	1732.5	1753.5		
3	QPSK	1	0	14.80	14.83	14.94	15.5	0
3	QPSK	1	8	14.77	14.89	15.07		
3	QPSK	1	14	14.73	14.71	15.20		
3	QPSK	8	0	15.00	15.08	15.01	15.5	0
3	QPSK	8	4	15.03	15.08	15.14		
3	QPSK	8	7	15.08	15.01	15.13		
3	QPSK	15	0	15.13	15.00	15.07	15.5	0
3	16QAM	1	0	14.91	14.93	14.83		
3	16QAM	1	8	14.62	14.66	15.32		
3	16QAM	1	14	14.90	14.59	14.75	15.5	0
3	16QAM	8	0	15.00	14.72	14.78		
3	16QAM	8	4	15.01	14.91	14.91		
3	16QAM	8	7	14.98	15.07	15.32	15.5	0
3	16QAM	15	0	15.13	14.92	15.14		
Channel				19957	20175	20393	Tune-up limit (dBm)	MPR (dB)
Frequency (MHz)				1710.7	1732.5	1754.3		
1.4	QPSK	1	0	15.14	14.95	15.08	15.5	0
1.4	QPSK	1	3	15.18	15.05	15.13		
1.4	QPSK	1	5	15.14	15.11	14.72		
1.4	QPSK	3	0	15.25	15.15	15.12		
1.4	QPSK	3	1	15.25	15.29	15.26		
1.4	QPSK	3	3	15.16	15.09	15.04		
1.4	QPSK	6	0	15.01	15.02	15.08	15.5	0
1.4	16QAM	1	0	14.76	15.05	14.84	15.5	0
1.4	16QAM	1	3	14.76	15.15	14.73		
1.4	16QAM	1	5	14.58	14.75	14.76		
1.4	16QAM	3	0	14.62	15.19	14.96		
1.4	16QAM	3	1	15.32	14.95	15.09		
1.4	16QAM	3	3	15.33	15.07	15.20		
1.4	16QAM	6	0	14.77	14.77	14.83	15.5	0



<LTE Band 5>

BW [MHz]	Modulation	RB Size	RB Offset	Power Low Ch. / Freq.	Power Middle Ch. / Freq.	Power High Ch. / Freq.	Tune-up limit (dBm)	MPR (dB)
Channel				20450	20525	20600		
Frequency (MHz)				829	836.5	844		
10	QPSK	1	0	19.76	19.98	19.73	20.5	0
10	QPSK	1	25	19.70	19.75	19.62		
10	QPSK	1	49	19.74	19.78	19.59		
10	QPSK	25	0	19.92	20.01	19.91	20.5	0
10	QPSK	25	12	19.96	19.90	19.90		
10	QPSK	25	25	19.93	19.88	19.88		
10	QPSK	50	0	19.89	19.95	19.87	20.5	0
10	16QAM	1	0	20.15	20.11	19.72		
10	16QAM	1	25	20.00	19.93	19.25		
10	16QAM	1	49	20.00	19.85	19.76	20.5	0
10	16QAM	25	0	19.97	19.96	19.95		
10	16QAM	25	12	20.03	19.95	19.86		
10	16QAM	25	25	20.17	19.86	20.05	20.5	0
10	16QAM	50	0	19.89	19.89	19.87		
Channel				20425	20525	20625	Tune-up limit (dBm)	MPR (dB)
Frequency (MHz)				826.5	836.5	846.5		
5	QPSK	1	0	19.85	19.78	19.67	20.5	0
5	QPSK	1	12	20.15	19.92	19.97		
5	QPSK	1	24	19.83	19.66	19.68		
5	QPSK	12	0	20.00	19.88	19.81	20.5	0
5	QPSK	12	7	19.99	19.90	19.80		
5	QPSK	12	13	20.00	19.86	19.80		
5	QPSK	25	0	20.02	19.92	19.85	20.5	0
5	16QAM	1	0	19.46	19.91	19.76		
5	16QAM	1	12	19.33	19.22	19.25		
5	16QAM	1	24	19.58	19.32	19.22	20.5	0
5	16QAM	12	0	19.86	19.89	19.69		
5	16QAM	12	7	19.94	19.75	19.74		
5	16QAM	12	13	19.85	19.79	19.76	20.5	0
5	16QAM	25	0	19.87	20.16	19.73		



Channel				20415	20525	20635	Tune-up limit (dBm)	MPR (dB)
Frequency (MHz)				825.5	836.5	847.5		
3	QPSK	1	0	20.15	19.75	19.80	20.5	0
3	QPSK	1	8	19.62	19.50	19.57		
3	QPSK	1	14	20.09	19.78	19.94		
3	QPSK	8	0	19.92	19.85	19.90	20.5	0
3	QPSK	8	4	20.10	19.87	19.79		
3	QPSK	8	7	20.05	19.86	19.94		
3	QPSK	15	0	20.01	19.92	19.89	20.5	0
3	16QAM	1	0	19.57	19.29	19.51		
3	16QAM	1	8	19.50	19.45	19.33		
3	16QAM	1	14	19.54	19.24	19.27	20.5	0
3	16QAM	8	0	20.15	19.84	19.53		
3	16QAM	8	4	20.09	19.96	19.57		
3	16QAM	8	7	19.69	20.03	19.52	20.5	0
3	16QAM	15	0	19.84	19.83	19.70		
Channel				20407	20525	20643	Tune-up limit (dBm)	MPR (dB)
Frequency (MHz)				824.7	836.5	848.3		
1.4	QPSK	1	0	19.99	19.64	19.84	20.5	0
1.4	QPSK	1	3	19.99	19.86	19.88		
1.4	QPSK	1	5	19.88	19.65	19.79		
1.4	QPSK	3	0	20.06	19.96	19.86		
1.4	QPSK	3	1	20.21	20.01	19.90		
1.4	QPSK	3	3	20.21	19.88	19.98		
1.4	QPSK	6	0	19.95	19.83	19.72	20.5	0
1.4	16QAM	1	0	19.79	19.63	19.91	20.5	0
1.4	16QAM	1	3	19.69	20.26	19.90		
1.4	16QAM	1	5	19.68	20.19	19.94		
1.4	16QAM	3	0	19.63	20.09	19.42		
1.4	16QAM	3	1	19.60	19.94	19.85		
1.4	16QAM	3	3	19.69	20.01	19.93		
1.4	16QAM	6	0	19.78	19.91	19.82	20.5	0



<LTE Band 7>

BW [MHz]	Modulation	RB Size	RB Offset	Power Low Ch. / Freq.	Power Middle Ch. / Freq.	Power High Ch. / Freq.	Tune-up limit (dBm)	MPR (dB)
Channel				20850	21100	21350		
Frequency (MHz)				2510	2535	2560		
20	QPSK	1	0	9.61	9.82	9.77	11.5	0
20	QPSK	1	49	10.51	10.79	10.45		
20	QPSK	1	99	10.41	10.59	9.96		
20	QPSK	50	0	11.33	11.41	11.21	11.5	0
20	QPSK	50	24	11.25	11.35	11.18		
20	QPSK	50	50	11.32	11.31	11.05		
20	QPSK	100	0	11.10	11.44	11.07	11.5	0
20	16QAM	1	0	9.77	9.97	10.17		
20	16QAM	1	49	10.90	11.18	11.18		
20	16QAM	1	99	10.58	10.76	10.12	11.5	0
20	16QAM	50	0	11.08	11.35	11.15		
20	16QAM	50	24	11.47	11.40	11.35		
20	16QAM	50	50	11.24	11.42	10.96	11.5	0
20	16QAM	100	0	11.00	11.42	10.96		
Channel				20825	21100	21375		
Frequency (MHz)				2507.5	2535	2562.5		
15	QPSK	1	0	10.91	11.11	11.08	11.5	0
15	QPSK	1	37	11.08	11.42	11.13		
15	QPSK	1	74	11.14	11.33	10.72		
15	QPSK	36	0	11.16	11.44	11.09	11.5	0
15	QPSK	36	20	11.10	11.47	11.14		
15	QPSK	36	39	11.19	11.48	11.01		
15	QPSK	75	0	11.06	11.44	11.08	11.5	0
15	16QAM	1	0	11.44	11.43	11.48		
15	16QAM	1	37	11.48	11.44	11.38		
15	16QAM	1	74	11.41	11.49	11.13	11.5	0
15	16QAM	36	0	11.08	11.35	11.00		
15	16QAM	36	20	11.26	11.44	11.28		
15	16QAM	36	39	11.12	11.47	10.97	11.5	0
15	16QAM	75	0	10.98	11.45	11.02		



Channel				20800	21100	21400	Tune-up limit (dBm)	MPR (dB)
Frequency (MHz)				2505	2535	2565		
10	QPSK	1	0	10.92	11.25	10.87	11.5	0
10	QPSK	1	25	11.16	11.47	11.07		
10	QPSK	1	49	10.92	11.34	10.61		
10	QPSK	25	0	11.13	11.48	11.11	11.5	0
10	QPSK	25	12	11.11	11.43	11.04		
10	QPSK	25	25	11.21	11.48	11.00		
10	QPSK	50	0	11.10	11.44	11.02	11.5	0
10	16QAM	1	0	10.83	11.26	10.87		
10	16QAM	1	25	11.29	11.45	11.30		
10	16QAM	1	49	10.81	11.37	10.66	11.5	0
10	16QAM	25	0	11.09	11.42	11.05		
10	16QAM	25	12	11.30	11.45	11.18		
10	16QAM	25	25	11.19	11.46	10.95	11.5	0
10	16QAM	50	0	11.10	11.36	10.94		
Channel				20775	21100	21425	Tune-up limit (dBm)	MPR (dB)
Frequency (MHz)				2502.5	2535	2567.5		
5	QPSK	1	0	10.76	11.11	10.63	11.5	0
5	QPSK	1	12	11.08	11.40	10.92		
5	QPSK	1	24	10.75	11.03	10.44		
5	QPSK	12	0	11.09	11.41	10.92	11.5	0
5	QPSK	12	7	11.12	11.44	10.96		
5	QPSK	12	13	11.04	11.30	10.81		
5	QPSK	25	0	11.05	11.36	10.87	11.5	0
5	16QAM	1	0	10.89	11.27	10.80		
5	16QAM	1	12	11.47	11.46	11.28		
5	16QAM	1	24	10.86	11.17	10.58	11.5	0
5	16QAM	12	0	11.08	11.38	10.87		
5	16QAM	12	7	11.32	11.44	11.12		
5	16QAM	12	13	11.25	11.49	11.01	11.5	0
5	16QAM	25	0	10.95	11.28	10.75		



<LTE Band 12>

BW [MHz]	Modulation	RB Size	RB Offset	Power Low Ch. / Freq.	Power Middle Ch. / Freq.	Power High Ch. / Freq.	Tune-up limit (dBm)	MPR (dB)
Channel				23060	23095	23130		
Frequency (MHz)				704	707.5	711		
10	QPSK	1	0	21.14	20.95	21.29	21.5	0
10	QPSK	1	25	21.27	21.33	21.24		
10	QPSK	1	49	21.08	21.30	21.29		
10	QPSK	25	0	21.43	21.40	21.48	21.5	0
10	QPSK	25	12	21.40	21.36	21.19		
10	QPSK	25	25	21.41	21.39	21.41		
10	QPSK	50	0	21.32	21.40	20.94	21.5	0
10	16QAM	1	0	21.28	21.26	21.40		
10	16QAM	1	25	21.19	21.43	20.92		
10	16QAM	1	49	21.49	21.40	21.42	21.5	0
10	16QAM	25	0	21.47	21.47	21.33		
10	16QAM	25	12	21.46	21.46	21.43		
10	16QAM	25	25	21.44	21.42	21.48	21.5	0
10	16QAM	50	0	21.46	21.35	21.47		
Channel				23035	23095	23155		
Frequency (MHz)				701.5	707.5	713.5		
5	QPSK	1	0	21.36	21.05	20.90	21.5	0
5	QPSK	1	12	21.42	21.25	21.06		
5	QPSK	1	24	21.03	21.09	21.05		
5	QPSK	12	0	21.43	21.34	21.37	21.5	0
5	QPSK	12	7	21.41	21.43	21.42		
5	QPSK	12	13	21.32	21.44	21.37		
5	QPSK	25	0	21.47	21.36	20.76	21.5	0
5	16QAM	1	0	20.99	21.06	21.45		
5	16QAM	1	12	21.45	21.06	21.49		
5	16QAM	1	24	21.13	20.39	21.06	21.5	0
5	16QAM	12	0	21.38	21.45	21.40		
5	16QAM	12	7	21.25	21.42	21.47		
5	16QAM	12	13	21.36	21.34	21.40	21.5	0
5	16QAM	25	0	21.42	21.28	21.45		



Channel				23025	23095	23165	Tune-up limit (dBm)	MPR (dB)
Frequency (MHz)				700.5	707.5	714.5		
3	QPSK	1	0	21.12	21.12	21.48	21.5	0
3	QPSK	1	8	21.09	21.09	21.31		
3	QPSK	1	14	21.44	21.00	21.45		
3	QPSK	8	0	21.35	21.47	21.33	21.5	0
3	QPSK	8	4	21.35	21.39	21.42		
3	QPSK	8	7	21.34	21.32	21.43		
3	QPSK	15	0	21.32	21.32	21.37	21.5	0
3	16QAM	1	0	21.13	20.82	21.47		
3	16QAM	1	8	20.93	21.10	21.27		
3	16QAM	1	14	21.17	21.41	21.35	21.5	0
3	16QAM	8	0	21.31	21.35	21.40		
3	16QAM	8	4	21.37	21.40	21.38		
3	16QAM	8	7	21.40	21.30	21.37	21.5	0
3	16QAM	15	0	21.15	21.42	21.30		
Channel				23017	23095	23173	Tune-up limit (dBm)	MPR (dB)
Frequency (MHz)				699.7	707.5	715.3		
1.4	QPSK	1	0	21.37	21.30	21.37	21.5	0
1.4	QPSK	1	3	21.44	21.32	21.36		
1.4	QPSK	1	5	21.06	21.20	21.48		
1.4	QPSK	3	0	21.44	21.37	21.42		
1.4	QPSK	3	1	21.33	21.39	21.43		
1.4	QPSK	3	3	21.26	21.34	21.43	21.5	0
1.4	QPSK	6	0	21.38	21.33	21.31		
1.4	16QAM	1	0	21.46	21.43	21.45	21.5	0
1.4	16QAM	1	3	21.40	21.46	21.38		
1.4	16QAM	1	5	21.49	21.48	21.08		
1.4	16QAM	3	0	21.30	21.43	21.47		
1.4	16QAM	3	1	21.29	21.41	21.45		
1.4	16QAM	3	3	21.31	21.36	21.45		
1.4	16QAM	6	0	21.16	21.18	21.38	21.5	0



<LTE Band 30>

BW [MHz]	Modulation	RB Size	RB Offset	Power Low Ch. / Freq.	Power Middle Ch. / Freq.	Power High Ch. / Freq.	Tune-up limit (dBm)	MPR (dB)
Channel				27710				
Frequency (MHz)				2310				
10	QPSK	1	0		15.57		16	0
10	QPSK	1	25		15.79			
10	QPSK	1	49		15.31			
10	QPSK	25	0		15.64		16	0
10	QPSK	25	12		15.61			
10	QPSK	25	25		15.51			
10	QPSK	50	0		15.71		16	0
10	16QAM	1	0		15.72			
10	16QAM	1	25		15.28			
10	16QAM	1	49		15.37		16	0
10	16QAM	25	0		15.65			
10	16QAM	25	12		15.63			
10	16QAM	25	25		15.63		16	0
10	16QAM	50	0		15.62			
Channel				27685	27710	27735	Tune-up limit (dBm)	MPR (dB)
Frequency (MHz)				2307.5	2310	2312.5		
5	QPSK	1	0	15.25	15.10	15.31	16	0
5	QPSK	1	12	15.60	15.76	15.49		
5	QPSK	1	24	15.20	15.13	15.18		
5	QPSK	12	0	15.47	15.54	15.49	16	0
5	QPSK	12	7	15.40	15.57	15.50		
5	QPSK	12	13	15.42	15.60	15.53		
5	QPSK	25	0	15.42	15.52	15.54	16	0
5	16QAM	1	0	15.41	15.57	15.35		
5	16QAM	1	12	15.43	15.75	15.50		
5	16QAM	1	24	15.03	15.50	15.02	16	0
5	16QAM	12	0	15.40	15.67	15.43		
5	16QAM	12	7	15.44	15.70	15.45		
5	16QAM	12	13	15.47	15.74	15.37	16	0
5	16QAM	25	0	15.64	15.44	15.46		



**LTE Carrier Aggregation Conducted Power**

**General Note:**

- i. According to KDB941225 D05A v01r02, Uplink maximum output power measurement with downlink carrier aggregation active should be measured, using the highest output channel measured without downlink carrier aggregation, to confirm that uplink maximum output power with downlink carrier aggregation active remains within the specified tune-up tolerance limits and not more than ¼ dB higher than the maximum output measured without downlink carrier aggregation active.
- ii. Uplink maximum output power with downlink carrier aggregation active does not show more than ¼ dB higher than the maximum output power without downlink carrier aggregation active, therefore SAR evaluation with downlink carrier aggregation active can be excluded.
- iii. The device supports downlink carrier aggregation only. Uplink carrier aggregation is not supported. For power measurement were control and acknowledge data is sent on uplink channels that operate identical to specifications when downlink carrier aggregation is inactive.
- iv. Selected highest measured power when downlink carrier aggregation is inactive for conducted power comparison with downlink carrier aggregation is active, to confirm that when downlink carrier aggregation is active uplink maximum output power remains within the specified tune-up tolerance limits and not more than ¼ dB higher than the maximum output power measured when downlink carrier aggregation inactive.
- v. For inter-band CA, the SCC selected highest bandwidth and near the middle of its transmission band. For SCC DL RB size and offset will base on the PCC corresponding RB allocation.

**Maximum Average RF Power (Proximity Sensor Inactive)**

Configure	PCC						SCC				Measured Power	
	LTE Band	BW (MHz)	Freq. (MHz)	Channel	UL# RB	UL RB Offset	LTE Band	BW (MHz)	Freq. (MHz)	Channel	LTE Rel 10 Tx. Power (dBm)	LTE Rel 8 Tx. Power (dBm)
Inter-Band	Band 2	20M	1860	18700	1	49	Band 5	10M	881.5	2525	23.15	23.17
	Band 5	10M	844	20600	1	0	Band 2	20M	1960	900	23.28	23.31
	Band 2	20M	1860	18700	1	49	Band 12	10M	737.5	5095	23.15	23.17
	Band 12	10M	704	23060	1	25	Band 2	20M	1960	900	23.14	23.15
	Band 2	20M	1860	18700	1	49	Band 29	10M	722.5	9715	23.16	23.17
	Band 4	20M	1732.5	20175	1	49	Band 5	10M	881.5	2525	23.30	23.32
	Band 5	10M	844	20600	1	0	Band 4	20M	2132.5	2175	23.28	23.31
	Band 4	20M	1732.5	20175	1	49	Band 12	10M	737.5	5095	23.28	23.32
	Band 12	10M	704	23060	1	25	Band 4	20M	2132.5	2175	23.11	23.15
Band 4	20M	1732.5	20175	1	49	Band 29	10M	722.5	9715	23.29	23.32	



Reduced Average RF Power (Proximity Sensor Active)

Configure	PCC						SCC				Measured Power	
	LTE Band	BW (MHz)	Freq. (MHz)	Channel	UL# RB	UL RB Offset	LTE Band	BW (MHz)	Freq. (MHz)	Channel	LTE Rel 10 Tx. Power (dBm)	LTE Rel 8 Tx. Power (dBm)
Inter-Band	Band 2	20M	1860	18700	1	49	Band 5	10M	881.5	2525	13.75	13.80
	Band 5	10M	836.5	20525	1	0	Band 2	20M	1960	900	19.95	19.98
	Band 2	20M	1860	18700	1	49	Band 12	10M	737.5	5095	13.72	13.80
	Band 12	10M	707.5	23095	1	25	Band 2	20M	1960	900	21.29	21.33
	Band 2	20M	1860	18700	1	49	Band 29	10M	722.5	9715	13.78	13.80
	Band 4	20M	1745	20300	1	49	Band 5	10M	881.5	2525	15.47	15.47
	Band 5	10M	836.5	20525	1	0	Band 4	20M	2132.5	2175	19.91	19.98
	Band 4	20M	1745	20300	1	49	Band 12	10M	737.5	5095	15.45	15.47
	Band 12	10M	707.5	23095	1	25	Band 4	20M	2132.5	2175	21.24	21.33
	Band 4	20M	1745	20300	1	49	Band 29	10M	722.5	9715	15.41	15.47

**<WLAN Conducted Power>****General Note:**

1. Per KDB 248227 D01v02r02, SAR test reduction is determined according to 802.11 transmission mode configurations and certain exposure conditions with multiple test positions. In the 2.4 GHz band, separate SAR procedures are applied to DSSS and OFDM configurations to simplify DSSS test requirements. For OFDM, in both 2.4 and 5 GHz bands, an initial test configuration must be determined for each standalone and aggregated frequency band, according to the transmission mode configuration with the highest maximum output power specified for production units to perform SAR measurements. If the same highest maximum output power applies to different combinations of channel bandwidths, modulations and data rates, additional procedures are applied to determine which test configurations require SAR measurement. When applicable, an initial test position may be applied to reduce the number of SAR measurements required for next to the ear, UMPC mini-tablet or hotspot mode configurations with multiple test positions.
2. For 2.4 GHz 802.11b DSSS, either the initial test position procedure for multiple exposure test positions or the DSSS procedure for fixed exposure position is applied; these are mutually exclusive. For 2.4 GHz and 5 GHz OFDM configurations, the initial test configuration is applied to measure SAR using either the initial test position procedure for multiple exposure test position configurations or the initial test configuration procedures for fixed exposure test conditions. Based on the reported SAR of the measured configurations and maximum output power of the transmission mode configurations that are not included in the initial test configuration, the subsequent test configuration and initial test position procedures are applied to determine if SAR measurements are required for the remaining OFDM transmission configurations. In general, the number of test channels that require SAR measurement is minimized based on maximum output power measured for the test sample(s).
3. For OFDM transmission configurations in the 2.4 GHz and 5 GHz bands, When the same maximum power is specified for multiple transmission modes in a frequency band, the largest channel bandwidth, lowest order modulation, lowest data rate and lowest order 802.11a/g/n/ac mode is used for SAR measurement, on the highest measured output power channel for each frequency band.
4. DSSS and OFDM configurations are considered separately according to the required SAR procedures. SAR is measured in the initial test position using the 802.11 transmission mode configuration required by the DSSS procedure or initial test configuration and subsequent test configuration(s) according to the OFDM procedures.18 The initial test position procedure is described in the following:
  - a. When the reported SAR of the initial test position is  $\leq 0.4$  W/kg, further SAR measurement is not required for the other test positions in that exposure configuration and 802.11 transmission mode combinations within the frequency band or aggregated band.
  - b. When the reported SAR of the test position is  $> 0.4$  W/kg, SAR is repeated for the 802.11 transmission mode configuration tested in the initial test position to measure the subsequent next closet/smallest test separation distance and maximum coupling test position on the highest maximum output power channel, until the report SAR is  $\leq 0.8$  W/kg or all required test position are tested.
  - c. For all positions/configurations, when the reported SAR is  $> 0.8$  W/kg, SAR is measured for these test positions/configurations on the subsequent next highest measured output power channel(s) until the reported SAR is  $\leq 1.2$  W/kg or all required channels are tested.



<2.4GHz WLAN>

	Mode	Channel	Frequency (MHz)	Average power (dBm)	Tune-Up Limit	Duty Cycle %
2.4GHz WLAN	802.11b 1Mbps	1	2412	15.00	15.50	97.59
		6	2437	14.84	15.50	
		11	2462	15.03	15.50	
	802.11g 6Mbps	1	2412	12.06	13.50	87.44
		6	2437	12.10	13.50	
		11	2462	12.00	13.50	
	802.11n-HT20 MCS0	1	2412	12.08	12.50	86.76
		6	2437	12.04	12.50	
		11	2462	12.15	12.50	
	802.11n-HT40 MCS0	1	2412	10.19	10.50	86.29
		6	2437	10.25	10.50	
		11	2462	10.22	10.50	



<5GHz WLAN>

	Mode	Channel	Frequency (MHz)	Average power (dBm)	Tune-Up Limit	Duty Cycle %
5.2GHz WLAN	802.11a 6Mbps	36	5180	11.10	12.00	87.44
		40	5200	11.04	12.00	
		44	5220	10.91	12.00	
		48	5240	11.05	12.00	
	802.11n-HT20 MCS0	36	5180	11.05	11.50	86.27
		40	5200	11.01	11.50	
		44	5220	10.99	11.50	
		48	5240	11.13	11.50	
	802.11n-HT40 MCS0	38	5190	10.29	11.00	86.08
		46	5230	10.23	11.00	
	802.11ac-VHT20 MCS0	36	5180	10.27	10.50	83.07
		40	5200	10.04	10.50	
		44	5220	10.08	10.50	
		48	5240	9.98	10.50	
802.11ac-VHT40 MCS0	38	5190	9.95	10.50	71.22	
	46	5230	9.98	10.50		
802.11ac-VHT80 MCS0	42	5210	9.82	10.50	55.16	

5.8GHz WLAN	Mode	Channel	Frequency (MHz)	Average power (dBm)	Tune-Up Limit	Duty Cycle %
	802.11a MCS0	149	5745	11.10	12.00	87.44
		157	5785	11.01	12.00	
		165	5825	10.83	12.00	
	802.11n-HT20 MCS0	149	5745	11.16	11.50	86.27
		157	5785	11.00	11.50	
		165	5825	10.93	11.50	
	802.11n-HT40 MCS0	151	5755	11.22	11.50	86.08
		159	5795	11.13	11.50	
	802.11ac-VHT20 MCS0	149	5745	10.22	10.50	83.07
157		5785	10.14	10.50		
165		5825	10.12	10.50		
802.11ac-VHT40 MCS0	151	5755	10.09	10.50	71.22	
	159	5795	10.00	10.50		
802.11ac-VHT80 MCS0	155	5775	10.00	10.50	55.16	

**<Bluetooth Conducted Power>**

Mode	Average power (dBm)
Bluetooth v3.0+EDR	7.0
Bluetooth v4.0/ v4.1/v4.2 LE	2.5

### 14. Antenna Location

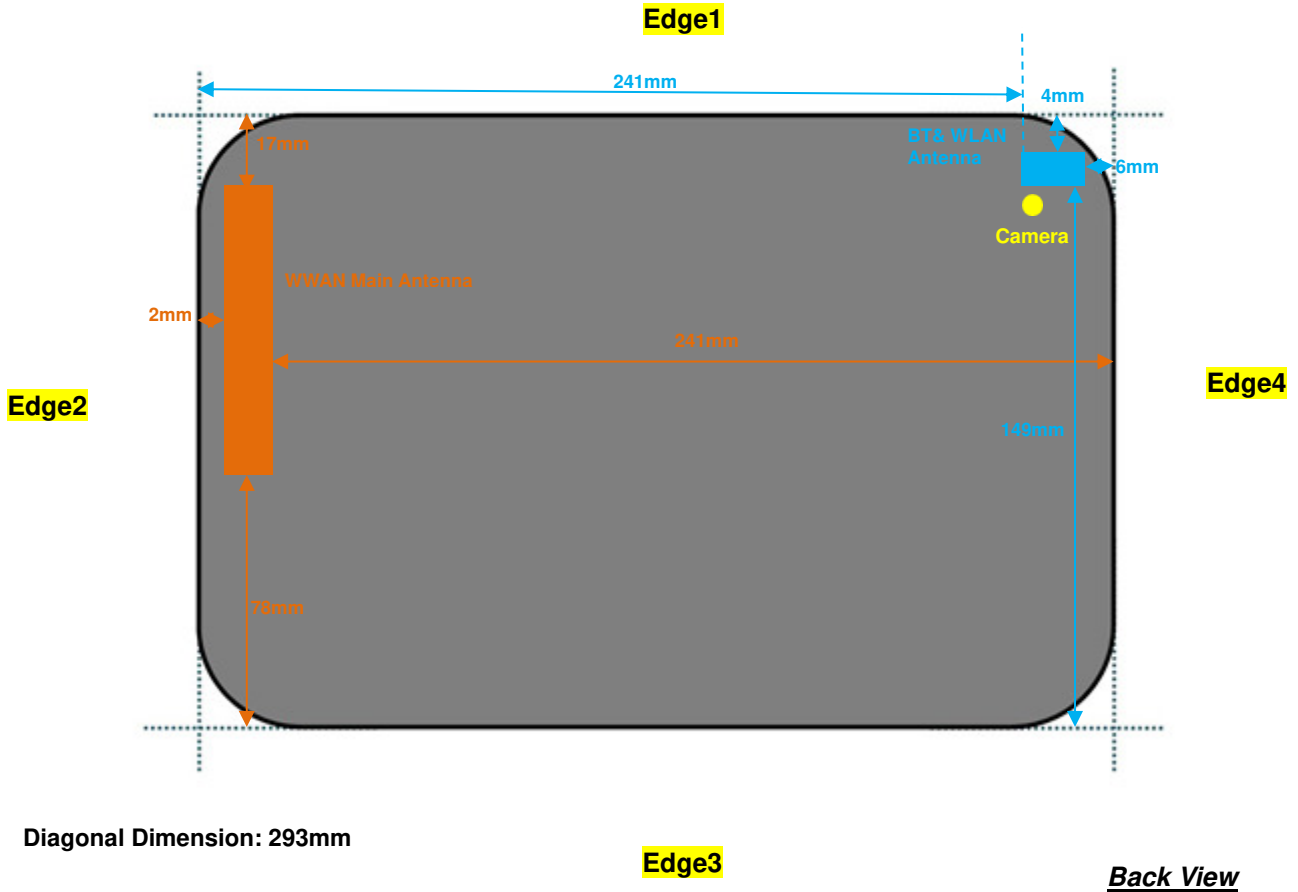



**General Note:**

- The below table, when the distance is < 50 mm exclusion threshold is "Ratio", when the distance is > 50 mm exclusion threshold is "mW"
- Maximum power is the source-based time-average power and represents the maximum RF output power among production units
- Per KDB 447498 D01v06, for larger devices, the test separation distance of adjacent edge configuration is determined by the closest separation between the antenna and the user.
- Per KDB 447498 D01v06, standalone SAR test exclusion threshold is applied; If the test separation distance is < 5mm, 5mm is used to determine SAR exclusion threshold.
- Per KDB 447498 D01v06, the 1-g and 10-g SAR test exclusion thresholds for 100 MHz to 6 GHz at *test separation distances* ≤ 50 mm are determined by:
  - $[(\text{max. power of channel, including tune-up tolerance, mW}) / (\text{min. test separation distance, mm})] \cdot \sqrt{f(\text{GHz})} \leq 3.0$  for 1-g SAR and ≤ 7.5 for 10-g extremity SAR
  - f(GHz) is the RF channel transmit frequency in GHz
  - Power and distance are rounded to the nearest mW and mm before calculation
  - The result is rounded to one decimal place for comparison
- Per KDB 447498 D01v06, at 100 MHz to 6 GHz and for *test separation distances* > 50 mm, the SAR test exclusion threshold is determined according to the following
  - [Threshold at 50 mm in step 1) + (test separation distance - 50 mm) · (f(MHz)/150)] mW, at 100 MHz to 1500 MHz
  - [Threshold at 50 mm in step 1) + (test separation distance - 50 mm) · 10] mW at > 1500 MHz and ≤ 6 GHz

Exposure Position	Wireless Interface	WCDMA Band V	WCDMA Band IV	WCDMA Band II	LTE Band 5	LTE Band 4	LTE Band 2	LTE Band 12	LTE Band 7	LTE Band 30
	Calculated Frequency	846MHz	1750MHz	1907MHz	848MHz	1754MHz	1909MHz	716MHz	2570MHz	2315MHz
	Maximum power (dBm)	23.5	23.5	23.5	23.5	23.5	23.5	23.5	23.5	24
	Maximum rated power(mW)	224.0	224.0	224.0	224.0	224.0	224.0	224.0	224.0	251.0
Bottom Face	Separation distance(mm)	0								
	exclusion threshold	41.2	59.3	61.9	41.3	59.3	61.9	62.0	71.8	82.3
	Testing required?	Yes	Yes	Yes	Yes	Yes	Yes	Yes	Yes	Yes
Edge 1	Separation distance(mm)	17.0								
	exclusion threshold	12.1	17.4	18.2	12.1	17.5	18.2	18.2	21.1	24.2
	Testing required?	Yes	Yes	Yes	Yes	Yes	Yes	Yes	Yes	Yes
Edge 2	Separation distance(mm)	2.0								
	exclusion threshold	41.2	59.3	61.9	41.3	59.3	61.9	62.0	71.8	82.3
	Testing required?	Yes	Yes	Yes	Yes	Yes	Yes	Yes	Yes	Yes
Edge 3	Separation distance(mm)	78.0								
	exclusion threshold	321.0	393.0	389.0	321.0	393.0	389.0	388.0	374.0	371.0
	Testing required?	No	No	No	No	No	No	No	No	No
Edge 4	Separation distance(mm)	241.0								
	exclusion threshold	1240.0	2023.0	2019.0	1243.0	2023.0	2019.0	2018.0	2004.0	2001.0
	Testing required?	No	No	No	No	No	No	No	No	No



Exposure Position	Wireless Interface	Bluetooth	2.4GHz WLAN	5GHz WLAN
	Calculated Frequency	2480MHz	2462MHz	5825MHz
	Maximum power (dBm)	7	15.5	12
	Maximum rated power(mW)	5.0	35.0	16.0
Bottom Face	Separation distance(mm)	0		
	exclusion threshold	1.6	11.0	7.7
	Testing required?	No	Yes	Yes
Edge 1	Separation distance(mm)	4.0		
	exclusion threshold	1.6	11.0	7.7
	Testing required?	No	Yes	Yes
Edge 2	Separation distance(mm)	241.0		
	exclusion threshold	2005.0	2006.0	1972.0
	Testing required?	No	No	No
Edge 3	Separation distance(mm)	149.0		
	exclusion threshold	1085.0	1086.0	1052.0
	Testing required?	No	No	No
Edge 4	Separation distance(mm)	6.0		
	exclusion threshold	1.3	9.2	6.4
	Testing required?	No	Yes	Yes



## **15. SAR Test Results**

### **General Note:**

1. Per KDB 447498 D01v06, the reported SAR is the measured SAR value adjusted for maximum tune-up tolerance.
  - a. Tune-up scaling Factor = tune-up limit power (mW) / EUT RF power (mW), where tune-up limit is the maximum rated power among all production units.
  - b. For SAR testing of WLAN signal with non-100% duty cycle, the measured SAR is scaled-up by the duty cycle scaling factor which is equal to "1/(duty cycle)"
  - c. For WWAN: Reported SAR(W/kg)= Measured SAR(W/kg)\*Tune-up Scaling Factor
  - d. For WLAN: Reported SAR(W/kg)= Measured SAR(W/kg)\* Duty Cycle scaling factor \* Tune-up scaling factor
2. Per KDB 447498 D01v06, for each exposure position, testing of other required channels within the operating mode of a frequency band is not required when the *reported* 1-g or 10-g SAR for the mid-band or highest output power channel is:
  - $\leq 0.8$  W/kg or 2.0 W/kg, for 1-g or 10-g respectively, when the transmission band is  $\leq 100$  MHz
  - $\leq 0.6$  W/kg or 1.5 W/kg, for 1-g or 10-g respectively, when the transmission band is between 100 MHz and 200 MHz
  - $\leq 0.4$  W/kg or 1.0 W/kg, for 1-g or 10-g respectively, when the transmission band is  $\geq 200$  MHz
3. Per KDB 865664 D01v01r04, for each frequency band, repeated SAR measurement is required only when the measured SAR is  $\geq 0.8$ W/kg.

### **Tablet Note:**

1. For the exposure positions that proximity sensor power reduction is applied for SAR compliance, additional SAR testing with EUT transmitting full power in normal mode was performed; 13mm for bottom face, 18mm for edge2.
2. Considering the curvature transition from bottom face to the edge, SAR testing at the curvature was performed. The SAR test setup is included in test setup photo exhibit, and the details of the curvature are included in operation description exhibit.
3. Per KDB 616217 D04v01r02, the additional separation introduced by the contour against a flat phantom is  $< 5$  mm on this device and reported SAR is  $< 1.2$  W/kg, a curved or contoured back surface or edge SAR is not required, more detail information please refer to the setup photo.
4. For SAR testing of the curved region of the device, the device was placed directly against the phantom at the point where the distance between the antenna and device exterior is a minimum.

### **UMTS Note:**

1. Per KDB 941225 D01v03r01, for SAR testing is measured using a 12.2 kbps RMC with TPC bits configured to all "1's".
2. Per KDB 941225 D01v03r01, RMC 12.2kbps setting is used to evaluate SAR. If the maximum output power and tune-up tolerance specified for production units in HSDPA / HSUPA / DC-HSDPA is  $\leq 1/4$  dB higher than RMC 12.2Kbps or when the highest reported SAR of the RMC12.2Kbps is scaled by the ratio of specified maximum output power and tune-up tolerance of HSDPA / HSUPA / DC-HSDPA to RMC12.2Kbps and the adjusted SAR is  $\leq 1.2$  W/kg, SAR measurement is not required for HSDPA / HSUPA / DC-HSDPA.

**LTE Note:**

1. Per KDB 941225 D05v02r05, start with the largest channel bandwidth and measure SAR for QPSK with 1 RB allocation, using the RB offset and required test channel combination with the highest maximum output power for RB offsets at the upper edge, middle and lower edge of each required test channel.
2. Per KDB 941225 D05v02r05, 50% RB allocation for QPSK SAR testing follows 1RB QPSK allocation procedure.
3. Per KDB 941225 D05v02r05, For QPSK with 100% RB allocation, SAR is not required when the highest maximum output power for 100 % RB allocation is less than the highest maximum output power in 50% and 1 RB allocations and the highest reported SAR for 1 RB and 50% RB allocation are  $\leq 0.8$  W/kg. Otherwise, SAR is measured for the highest output power channel; and if the reported SAR is  $> 1.45$  W/kg, the remaining required test channels must also be tested.
4. Per KDB 941225 D05v02r05, 16QAM output power for each RB allocation configuration is  $>$  not  $\frac{1}{2}$  dB higher than the same configuration in QPSK and the reported SAR for the QPSK configuration is  $\leq 1.45$  W/kg; Per KDB 941225 D05v02r05, 16QAM SAR testing is not required.
5. Per KDB 941225 D05v02r05, Smaller bandwidth output power for each RB allocation configuration is  $>$  not  $\frac{1}{2}$  dB higher than the same configuration in the largest supported bandwidth, and the reported SAR for the largest supported bandwidth is  $\leq 1.45$  W/kg; Per KDB 941225 D05v02r05, smaller bandwidth SAR testing is not required.
6. For LTE B12 / B5 / B4 the maximum bandwidth does not support three non-overlapping channels, per KDB 941225 D05v02r05, when a device supports overlapping channel assignment in a channel bandwidth configuration, the middle channel of the group of overlapping channels should be selected for testing.

**WLAN Note:**

1. Per KDB 248227 D01v02r02, for 2.4GHz 802.11g/n SAR testing is not required when the highest reported SAR for DSSS is adjusted by the ratio of OFDM to DSSS specified maximum output power and the adjusted SAR is  $\leq 1.2$  W/kg.
2. When the reported SAR of the test position is  $> 0.4$  W/kg, SAR is repeated for the 802.11 transmission mode configuration tested in the initial test position to measure the subsequent next closet/smallest test separation distance and maximum coupling test position on the highest maximum output power channel, until the report SAR is  $\leq 0.8$  W/kg or all required test position are tested.
3. For all positions / configurations, when the reported SAR is  $> 0.8$  W/kg, SAR is measured for these test positions / configurations on the subsequent next highest measured output power channel(s) until the reported SAR is  $\leq 1.2$  W/kg or all required channels are tested.
4. During SAR testing the WLAN transmission was verified using a spectrum analyzer.
5. WLAN Bottom face 13mm SAR testing is for co-located with WWAN analysis.



15.1 Body SAR

<WCDMA SAR>

Plot No.	Band	Mode	Test Position	Gap (mm)	Power Reduction	Ch.	Freq. (MHz)	Average Power (dBm)	Tune-Up Limit (dBm)	Tune-up Scaling Factor	Power Drift (dB)	Measured 1g SAR (W/kg)	Reported 1g SAR (W/kg)
01	WCDMA Band V	RMC 12.2Kbps	Bottom Face	13	OFF	4182	836.4	23.35	23.5	1.035	0.02	0.364	0.377
	WCDMA Band V	RMC 12.2Kbps	Edge 1	0	OFF	4182	836.4	23.35	23.5	1.035	0.03	0.168	0.174
	WCDMA Band V	RMC 12.2Kbps	Edge 2	18	OFF	4182	836.4	23.35	23.5	1.035	-0.11	0.134	0.139
	WCDMA Band V	RMC 12.2Kbps	Bottom Face	0	ON	4182	836.4	20.38	20.5	1.028	0.04	1.010	1.038
	WCDMA Band V	RMC 12.2Kbps	Bottom Face	0	ON	4132	826.4	20.26	20.5	1.057	0.01	0.976	1.031
	WCDMA Band V	RMC 12.2Kbps	Bottom Face	0	ON	4233	846.6	20.23	20.5	1.064	0.14	1.070	1.139
	WCDMA Band V	RMC 12.2Kbps	Edge 2	0	ON	4182	836.4	20.38	20.5	1.028	0.06	0.624	0.641
	WCDMA Band V	RMC 12.2Kbps	Curved Edge2	0	ON	4182	836.4	20.38	20.5	1.028	-0.08	0.766	0.787
	WCDMA Band IV	RMC 12.2Kbps	Bottom Face	13	OFF	1413	1732.6	23.19	23.5	1.074	-0.05	0.674	0.724
02	WCDMA Band IV	RMC 12.2Kbps	Edge 1	0	OFF	1413	1732.6	23.19	23.5	1.074	0.05	0.499	0.536
	WCDMA Band IV	RMC 12.2Kbps	Edge 2	18	OFF	1413	1732.6	23.19	23.5	1.074	0.12	0.533	0.572
	WCDMA Band IV	RMC 12.2Kbps	Bottom Face	0	ON	1413	1732.6	15.04	15.5	1.112	0.12	0.582	0.647
	WCDMA Band IV	RMC 12.2Kbps	Edge 2	0	ON	1413	1732.6	15.04	15.5	1.112	0.05	1.030	1.145
	WCDMA Band IV	RMC 12.2Kbps	Edge 2	0	ON	1312	1712.4	15.03	15.5	1.114	0.03	0.951	1.060
	WCDMA Band IV	RMC 12.2Kbps	Edge 2	0	ON	1513	1752.6	14.85	15.5	1.161	0.12	0.863	1.002
	WCDMA Band IV	RMC 12.2Kbps	Curved Edge2	0	ON	1413	1732.6	15.04	15.5	1.112	-0.1	0.960	1.067
	WCDMA Band IV	RMC 12.2Kbps	Curved Edge2	0	ON	1312	1712.4	15.03	15.5	1.114	0.07	0.848	0.945
	WCDMA Band IV	RMC 12.2Kbps	Curved Edge2	0	ON	1513	1752.6	14.85	15.5	1.161	-0.09	1.010	1.173
03	WCDMA Band II	RMC 12.2Kbps	Bottom Face	13	OFF	9400	1880	23.28	23.5	1.052	-0.01	1.080	1.136
	WCDMA Band II	RMC 12.2Kbps	Bottom Face	13	OFF	9262	1852.4	23.24	23.5	1.062	0.07	0.898	0.953
	WCDMA Band II	RMC 12.2Kbps	Bottom Face	13	OFF	9538	1907.6	23.22	23.5	1.067	0.06	1.100	1.173
	WCDMA Band II	RMC 12.2Kbps	Edge 1	0	OFF	9400	1880	23.28	23.5	1.052	0.13	0.330	0.347
	WCDMA Band II	RMC 12.2Kbps	Edge 2	18	OFF	9400	1880	23.28	23.5	1.052	-0.08	0.837	0.880
	WCDMA Band II	RMC 12.2Kbps	Edge 2	18	OFF	9262	1852.4	23.24	23.5	1.062	-0.14	0.812	0.862
	WCDMA Band II	RMC 12.2Kbps	Edge 2	18	OFF	9538	1907.6	23.22	23.5	1.067	0.19	1.000	1.067
	WCDMA Band II	RMC 12.2Kbps	Bottom Face	0	ON	9400	1880	14.03	14.5	1.114	0.05	0.704	0.784
	WCDMA Band II	RMC 12.2Kbps	Edge 2	0	ON	9400	1880	14.03	14.5	1.114	0.03	0.758	0.845
	WCDMA Band II	RMC 12.2Kbps	Edge 2	0	ON	9262	1852.4	13.89	14.5	1.151	0.08	0.721	0.830
	WCDMA Band II	RMC 12.2Kbps	Edge 2	0	ON	9538	1907.6	14.02	14.5	1.117	0.01	0.711	0.794
	WCDMA Band II	RMC 12.2Kbps	Curved Edge2	0	ON	9400	1880	14.03	14.5	1.114	-0.09	1.010	1.125
WCDMA Band II	RMC 12.2Kbps	Curved Edge2	0	ON	9262	1852.4	13.89	14.5	1.151	0.01	0.936	1.077	
WCDMA Band II	RMC 12.2Kbps	Curved Edge2	0	ON	9538	1907.6	14.02	14.5	1.117	-0.09	0.878	0.981	



<LTE SAR>

Plot No.	Band	BW (MHz)	Modulation	RB Size	RB offset	Test Position	Gap (mm)	Power Reduction	Ch.	Freq. (MHz)	Average Power (dBm)	Tune-Up Limit (dBm)	Tune-up Scaling Factor	Power Drift (dB)	Measured 1g SAR (W/kg)	Reported 1g SAR (W/kg)
	LTE Band 12	10M	QPSK	1RB	25Offset	Bottom Face	13	OFF	23095	707.5	22.83	23.5	1.167	0.12	0.318	0.371
	LTE Band 12	10M	QPSK	25RB	0Offset	Bottom Face	13	OFF	23095	707.5	21.99	22.5	1.125	-0.13	0.248	0.279
	LTE Band 12	10M	QPSK	1RB	25Offset	Edge 1	0	OFF	23095	707.5	22.83	23.5	1.167	0.09	0.160	0.187
	LTE Band 12	10M	QPSK	25RB	0Offset	Edge 1	0	OFF	23095	707.5	21.99	22.5	1.125	-0.04	0.116	0.130
	LTE Band 12	10M	QPSK	1RB	25Offset	Edge 2	18	OFF	23095	707.5	22.83	23.5	1.167	0.04	0.149	0.174
	LTE Band 12	10M	QPSK	25RB	0Offset	Edge 2	18	OFF	23095	707.5	21.99	22.5	1.125	0.04	0.116	0.130
	LTE Band 12	10M	QPSK	1RB	25Offset	Bottom Face	0	ON	23095	707.5	21.33	21.5	1.040	-0.14	1.070	1.113
04	LTE Band 12	10M	QPSK	25RB	0Offset	Bottom Face	0	ON	23095	707.5	21.40	21.5	1.023	0.08	1.120	1.146
	LTE Band 12	10M	QPSK	50RB	0Offset	Bottom Face	0	ON	23095	707.5	21.40	21.5	1.023	-0.08	1.010	1.034
	LTE Band 12	10M	QPSK	1RB	25Offset	Edge 2	0	ON	23095	707.5	21.33	21.5	1.040	0.08	0.595	0.619
	LTE Band 12	10M	QPSK	25RB	0Offset	Edge 2	0	ON	23095	707.5	21.40	21.5	1.023	0.02	0.509	0.521
	LTE Band 12	10M	QPSK	1RB	25Offset	Curved Edge2	0	ON	23095	707.5	21.13	21.5	1.089	-0.12	0.801	0.872
	LTE Band 12	10M	QPSK	25RB	0Offset	Curved Edge2	0	ON	23095	707.5	21.40	21.5	1.023	-0.11	0.791	0.809
	LTE Band 12	10M	QPSK	50RB	0Offset	Curved Edge2	0	ON	23095	707.5	21.40	21.5	1.023	0.09	0.779	0.797
	LTE Band 5	10M	QPSK	1RB	0Offset	Bottom Face	13	OFF	20525	836.5	23.17	23.5	1.079	0.06	0.318	0.343
	LTE Band 5	10M	QPSK	25RB	0Offset	Bottom Face	13	OFF	20525	836.5	22.12	22.5	1.091	-0.19	0.243	0.265
	LTE Band 5	10M	QPSK	1RB	0Offset	Edge 1	0	OFF	20525	836.5	23.17	23.5	1.079	0.03	0.155	0.167
	LTE Band 5	10M	QPSK	25RB	0Offset	Edge 1	0	OFF	20525	836.5	22.12	22.5	1.091	-0.07	0.111	0.121
	LTE Band 5	10M	QPSK	1RB	0Offset	Edge 2	18	OFF	20525	836.5	23.17	23.5	1.079	0.08	0.117	0.126
	LTE Band 5	10M	QPSK	25RB	0Offset	Edge 2	18	OFF	20525	836.5	22.12	22.5	1.091	0.09	0.096	0.105
	LTE Band 5	10M	QPSK	1RB	0Offset	Bottom Face	0	ON	20525	836.5	19.98	20.5	1.127	-0.07	0.982	1.107
	LTE Band 5	10M	QPSK	25RB	0Offset	Bottom Face	0	ON	20525	836.5	20.01	20.5	1.119	-0.01	0.973	1.089
	LTE Band 5	10M	QPSK	50RB	0Offset	Bottom Face	0	ON	20525	836.5	19.95	20.5	1.135	-0.06	0.972	1.103
05	LTE Band 5	10M	QPSK	1RB	0Offset	Edge 2	0	ON	20525	836.5	19.98	20.5	1.127	0.03	1.060	1.195
	LTE Band 5	10M	QPSK	25RB	0Offset	Edge 2	0	ON	20525	836.5	20.01	20.5	1.119	0.04	0.838	0.938
	LTE Band 5	10M	QPSK	50RB	0Offset	Edge 2	0	ON	20525	836.5	19.95	20.5	1.135	0.02	0.821	0.932
	LTE Band 5	10M	QPSK	1RB	0Offset	Curved Edge2	0	ON	20525	836.5	19.98	20.5	1.127	-0.01	0.711	0.801
	LTE Band 5	10M	QPSK	25RB	0Offset	Curved Edge2	0	ON	20525	836.5	20.01	20.5	1.119	-0.12	0.720	0.806
	LTE Band 5	10M	QPSK	50RB	0Offset	Curved Edge2	0	ON	20525	836.5	19.95	20.5	1.135	0.01	0.700	0.795



Plot No.	Band	BW (MHz)	Modulation	RB Size	RB offset	Test Position	Gap (mm)	Power Reduction	Ch.	Freq. (MHz)	Average Power (dBm)	Tune-Up Limit (dBm)	Tune-up Scaling Factor	Power Drift (dB)	Measured 1g SAR (W/kg)	Reported 1g SAR (W/kg)
	LTE Band 4	20M	QPSK	1RB	49Offset	Bottom Face	13	OFF	20175	1732.5	23.32	23.5	1.042	-0.09	0.586	0.611
	LTE Band 4	20M	QPSK	50RB	0Offset	Bottom Face	13	OFF	20175	1732.5	21.98	22.5	1.127	0.01	0.463	0.522
	LTE Band 4	20M	QPSK	1RB	49Offset	Edge 1	0	OFF	20175	1732.5	23.32	23.5	1.042	0.19	0.461	0.481
	LTE Band 4	20M	QPSK	50RB	0Offset	Edge 1	0	OFF	20175	1732.5	21.98	22.5	1.127	0.03	0.377	0.425
	LTE Band 4	20M	QPSK	1RB	49Offset	Edge 2	18	OFF	20175	1732.5	23.32	23.5	1.042	0.07	0.456	0.475
	LTE Band 4	20M	QPSK	50RB	0Offset	Edge 2	18	OFF	20175	1732.5	21.98	22.5	1.127	-0.05	0.377	0.425
	LTE Band 4	20M	QPSK	1RB	49Offset	Bottom Face	0	ON	20175	1732.5	15.23	15.5	1.064	-0.09	0.561	0.597
	LTE Band 4	20M	QPSK	50RB	0Offset	Bottom Face	0	ON	20175	1732.5	15.09	15.5	1.099	-0.19	0.557	0.612
	LTE Band 4	20M	QPSK	1RB	49Offset	Edge 2	0	ON	20175	1732.5	15.23	15.5	1.064	0.09	1.040	1.107
	LTE Band 4	20M	QPSK	50RB	0Offset	Edge 2	0	ON	20175	1732.5	15.09	15.5	1.099	0.02	1.020	1.121
06	LTE Band 4	20M	QPSK	100RB	0Offset	Edge 2	0	ON	20175	1732.5	14.97	15.5	1.130	0.14	1.060	1.198
	LTE Band 4	20M	QPSK	1RB	49Offset	Curved Edge2	0	ON	20175	1732.5	15.23	15.5	1.064	-0.06	0.954	1.015
	LTE Band 4	20M	QPSK	50RB	0Offset	Curved Edge2	0	ON	20175	1732.5	15.09	15.5	1.099	-0.09	0.922	1.013
	LTE Band 4	20M	QPSK	100RB	0Offset	Curved Edge2	0	ON	20175	1732.5	14.97	15.5	1.130	-0.09	0.910	1.028
	LTE Band 2	20M	QPSK	1RB	49Offset	Bottom Face	13	OFF	18700	1860	23.17	23.5	1.079	-0.05	0.746	0.805
	LTE Band 2	20M	QPSK	1RB	49Offset	Bottom Face	13	OFF	18900	1880	23.03	23.5	1.114	-0.02	0.848	0.945
	LTE Band 2	20M	QPSK	1RB	49Offset	Bottom Face	13	OFF	19100	1900	23.03	23.5	1.114	-0.15	0.991	1.104
	LTE Band 2	20M	QPSK	50RB	0Offset	Bottom Face	13	OFF	18700	1860	22.01	22.5	1.119	-0.07	0.723	0.809
	LTE Band 2	20M	QPSK	50RB	0Offset	Bottom Face	13	OFF	18900	1880	21.93	22.5	1.140	-0.06	0.646	0.737
	LTE Band 2	20M	QPSK	50RB	0Offset	Bottom Face	13	OFF	19100	1900	21.97	22.5	1.130	0.03	0.744	0.841
	LTE Band 2	20M	QPSK	100RB	0Offset	Bottom Face	13	OFF	18700	1860	22.01	22.5	1.119	-0.07	0.595	0.666
	LTE Band 2	20M	QPSK	1RB	49Offset	Edge 1	0	OFF	18700	1860	23.17	23.5	1.079	0.09	0.312	0.337
	LTE Band 2	20M	QPSK	50RB	0Offset	Edge 1	0	OFF	18700	1860	22.01	22.5	1.119	0.12	0.255	0.285
	LTE Band 2	20M	QPSK	1RB	49Offset	Edge 2	18	OFF	18700	1860	23.17	23.5	1.079	-0.16	0.730	0.788
	LTE Band 2	20M	QPSK	50RB	0Offset	Edge 2	18	OFF	18700	1860	22.01	22.5	1.119	0.03	0.583	0.653
	LTE Band 2	20M	QPSK	1RB	49Offset	Bottom Face	0	ON	18700	1860	13.80	14	1.047	0.04	0.686	0.718
	LTE Band 2	20M	QPSK	50RB	0Offset	Bottom Face	0	ON	18700	1860	13.74	14	1.062	0.06	0.686	0.728
	LTE Band 2	20M	QPSK	1RB	49Offset	Edge 2	0	ON	18700	1860	13.80	14	1.047	0.07	0.821	0.860
	LTE Band 2	20M	QPSK	1RB	49Offset	Edge 2	0	ON	18900	1880	13.65	14	1.084	0.12	0.791	0.857
	LTE Band 2	20M	QPSK	1RB	49Offset	Edge 2	0	ON	19100	1900	13.59	14	1.099	0.15	0.915	1.006
	LTE Band 2	20M	QPSK	50RB	0Offset	Edge 2	0	ON	18700	1860	13.74	14	1.062	0.03	0.834	0.885
	LTE Band 2	20M	QPSK	50RB	0Offset	Edge 2	0	ON	18900	1880	13.62	14	1.091	0.12	0.807	0.881
	LTE Band 2	20M	QPSK	50RB	0Offset	Edge 2	0	ON	19100	1900	13.45	14	1.135	0.17	0.835	0.948
	LTE Band 2	20M	QPSK	100RB	0Offset	Edge 2	0	ON	18700	1860	13.70	14	1.072	0.08	0.719	0.770
	LTE Band 2	20M	QPSK	1RB	49Offset	Curved Edge2	0	ON	18700	1860	13.80	14	1.047	0.09	0.931	0.975
	LTE Band 2	20M	QPSK	1RB	49Offset	Curved Edge2	0	ON	18900	1880	13.65	14	1.084	0.1	0.960	1.041
07	LTE Band 2	20M	QPSK	1RB	49Offset	Curved Edge2	0	ON	19100	1900	13.59	14	1.099	-0.09	1.080	1.187
	LTE Band 2	20M	QPSK	50RB	0Offset	Curved Edge2	0	ON	18700	1860	13.74	14	1.062	-0.08	0.950	1.009
	LTE Band 2	20M	QPSK	50RB	0Offset	Curved Edge2	0	ON	18900	1880	13.62	14	1.091	0.01	0.937	1.023
	LTE Band 2	20M	QPSK	50RB	0Offset	Curved Edge2	0	ON	19100	1900	13.45	14	1.135	-0.08	1.040	1.180
	LTE Band 2	20M	QPSK	100RB	0Offset	Curved Edge2	0	ON	18700	1860	13.70	14	1.072	0.07	0.948	1.016



Plot No.	Band	BW (MHz)	Modulation	RB Size	RB offset	Test Position	Gap (mm)	Power Reduction	Ch.	Freq. (MHz)	Average Power (dBm)	Tune-Up Limit (dBm)	Tune-up Scaling Factor	Power Drift (dB)	Measured 1g SAR (W/kg)	Reported 1g SAR (W/kg)
	LTE Band 30	10M	QPSK	1RB	25Offset	Bottom Face	13	OFF	27710	2310	23.67	24	1.079	0.01	0.717	0.774
	LTE Band 30	10M	QPSK	25RB	0Offset	Bottom Face	13	OFF	27710	2310	22.68	23	1.076	0.03	0.586	0.631
	LTE Band 30	10M	QPSK	1RB	25Offset	Edge 1	0	OFF	27710	2310	23.67	24	1.079	0.06	0.974	1.051
	LTE Band 30	10M	QPSK	25RB	0Offset	Edge 1	0	OFF	27710	2310	22.68	23	1.076	0.07	0.787	0.847
	LTE Band 30	10M	QPSK	50RB	0Offset	Edge 1	0	OFF	27710	2310	22.61	23	1.094	0.07	0.745	0.815
	LTE Band 30	10M	QPSK	1RB	25Offset	Edge 2	18	OFF	27710	2310	23.67	24	1.079	0.03	0.553	0.597
	LTE Band 30	10M	QPSK	25RB	0Offset	Edge 2	18	OFF	27710	2310	22.68	23	1.076	0.06	0.463	0.498
08	LTE Band 30	10M	QPSK	1RB	25Offset	Bottom Face	0	ON	27710	2310	15.79	16	1.050	-0.09	1.140	1.196
	LTE Band 30	10M	QPSK	25RB	0Offset	Bottom Face	0	ON	27710	2310	15.64	16	1.086	-0.06	1.060	1.152
	LTE Band 30	10M	QPSK	50RB	0Offset	Bottom Face	0	ON	27710	2310	15.71	16	1.069	-0.19	1.090	1.165
	LTE Band 30	10M	QPSK	1RB	25Offset	Edge 2	0	ON	27710	2310	15.79	16	1.050	0.07	0.543	0.570
	LTE Band 30	10M	QPSK	25RB	0Offset	Edge 2	0	ON	27710	2310	15.64	16	1.086	0.19	0.565	0.614
	LTE Band 30	10M	QPSK	1RB	25Offset	Curved Edge2	0	ON	27710	2310	15.79	16	1.050	-0.06	0.670	0.703
	LTE Band 30	10M	QPSK	25RB	0Offset	Curved Edge2	0	ON	27710	2310	15.64	16	1.086	0.02	0.662	0.719
	LTE Band 7	20M	QPSK	1RB	49Offset	Bottom Face	13	OFF	21100	2535	23.23	23.5	1.064	-0.04	0.974	1.036
09	LTE Band 7	20M	QPSK	1RB	49Offset	Bottom Face	13	OFF	20850	2510	22.92	23.5	1.143	-0.07	0.993	1.135
	LTE Band 7	20M	QPSK	1RB	49Offset	Bottom Face	13	OFF	21350	2560	23.04	23.5	1.112	-0.04	0.984	1.094
	LTE Band 7	20M	QPSK	50RB	0Offset	Bottom Face	13	OFF	21100	2535	22.16	22.5	1.081	-0.01	0.809	0.875
	LTE Band 7	20M	QPSK	50RB	0Offset	Bottom Face	13	OFF	20850	2535	22.04	22.5	1.112	0.02	0.839	0.933
	LTE Band 7	20M	QPSK	50RB	0Offset	Bottom Face	13	OFF	21350	2560	22.14	22.5	1.086	0.02	0.804	0.873
	LTE Band 7	20M	QPSK	100RB	0Offset	Bottom Face	13	OFF	21100	2535	22.17	22.5	1.079	-0.05	0.774	0.835
	LTE Band 7	20M	QPSK	1RB	49Offset	Edge 1	0	OFF	21100	2535	23.23	23.5	1.064	0.16	0.795	0.846
	LTE Band 7	20M	QPSK	1RB	49Offset	Edge 1	0	OFF	20850	2510	22.92	23.5	1.143	0.02	0.869	0.993
	LTE Band 7	20M	QPSK	1RB	49Offset	Edge 1	0	OFF	21350	2560	23.04	23.5	1.112	0.03	0.765	0.850
	LTE Band 7	20M	QPSK	50RB	0Offset	Edge 1	0	OFF	21100	2535	22.16	22.5	1.081	0.03	0.669	0.723
	LTE Band 7	20M	QPSK	100RB	0Offset	Edge 1	0	OFF	21100	2535	22.17	22.5	1.079	0.12	0.658	0.710
	LTE Band 7	20M	QPSK	1RB	49Offset	Edge 2	18	OFF	21100	2535	23.23	23.5	1.064	0.03	0.368	0.392
	LTE Band 7	20M	QPSK	50RB	0Offset	Edge 2	18	OFF	21100	2535	22.16	22.5	1.081	-0.03	0.306	0.331
	LTE Band 7	20M	QPSK	1RB	49Offset	Bottom Face	0	ON	21100	2535	10.79	11.5	1.178	-0.09	0.894	1.053
	LTE Band 7	20M	QPSK	1RB	49Offset	Bottom Face	0	ON	20850	2510	10.51	11.5	1.256	0.05	0.818	1.027
	LTE Band 7	20M	QPSK	1RB	49Offset	Bottom Face	0	ON	21350	2560	10.45	11.5	1.274	0.09	0.621	0.791
	LTE Band 7	20M	QPSK	50RB	0Offset	Bottom Face	0	ON	21100	2535	11.41	11.5	1.021	0.07	0.938	0.958
	LTE Band 7	20M	QPSK	50RB	0Offset	Bottom Face	0	ON	20850	2510	11.33	11.5	1.040	0.16	0.944	0.982
	LTE Band 7	20M	QPSK	50RB	0Offset	Bottom Face	0	ON	21350	2560	11.21	11.5	1.069	-0.15	0.725	0.775
	LTE Band 7	20M	QPSK	100RB	0Offset	Bottom Face	0	ON	21100	2535	11.44	11.5	1.014	-0.04	0.989	1.003
	LTE Band 7	20M	QPSK	1RB	49Offset	Edge 2	0	ON	21100	2535	10.79	11.5	1.178	0.07	0.316	0.372
	LTE Band 7	20M	QPSK	50RB	0Offset	Edge 2	0	ON	21100	2535	11.41	11.5	1.021	0.17	0.355	0.362
	LTE Band 7	20M	QPSK	1RB	49Offset	Curved Edge2	0	ON	21100	2535	10.79	11.5	1.178	-0.03	0.485	0.571
	LTE Band 7	20M	QPSK	50RB	0Offset	Curved Edge2	0	ON	21100	2535	11.41	11.5	1.021	0.04	0.534	0.545



<WLAN SAR>

Plot No.	Band	Mode	Test Position	Gap (mm)	Ch.	Freq. (MHz)	Average Power (dBm)	Tune-Up Limit (dBm)	Tune-up Scaling Factor	Duty Cycle %	Duty Cycle Scaling Factor	Power Drift (dB)	Measured 1g SAR (W/kg)	Reported 1g SAR (W/kg)
	WLAN 2.4GHz	802.11b 1Mbps	Bottom Face	13	11	2462	15.03	15.5	1.114	97.59	1.025	0.04	0.034	0.039
	WLAN 2.4GHz	802.11b 1Mbps	Edge 1	0	11	2462	15.03	15.5	1.114	97.59	1.025	0.09	0.204	0.233
	WLAN 2.4GHz	802.11b 1Mbps	Edge 4	0	11	2462	15.03	15.5	1.114	97.59	1.025	0.04	0.282	0.322
10	WLAN 2.4GHz	802.11b 1Mbps	Bottom Face	0	11	2462	15.03	15.5	1.114	97.59	1.025	0.02	0.466	0.532
	WLAN 2.4GHz	802.11b 1Mbps	Curved Edge4	0	11	2462	15.03	15.5	1.114	97.59	1.025	-0.13	0.219	0.250

Plot No.	Band	Mode	Test Position	Gap (mm)	Ch.	Freq. (MHz)	Average Power (dBm)	Tune-Up Limit (dBm)	Tune-up Scaling Factor	Duty Cycle %	Duty Cycle Scaling Factor	Power Drift (dB)	Measured 1g SAR (W/kg)	Reported 1g SAR (W/kg)
	WLAN 5.2GHz	802.11a 6Mbps	Bottom Face	13	36	5180	11.1	12	1.230	87.44	1.144	0.05	0.017	0.024
	WLAN 5.2GHz	802.11a 6Mbps	Edge 1	0	36	5180	11.1	12	1.230	87.44	1.144	0.15	0.186	0.262
	WLAN 5.2GHz	802.11a 6Mbps	Edge 4	0	36	5180	11.1	12	1.230	87.44	1.144	0.06	0.303	0.426
11	WLAN 5.2GHz	802.11a 6Mbps	Bottom Face	0	36	5180	11.1	12	1.230	87.44	1.144	0.02	0.473	0.666
	WLAN 5.2GHz	802.11a 6Mbps	Curved Edge4	0	36	5180	11.1	12	1.230	87.44	1.144	0.07	0.315	0.443
	WLAN 5.8GHz	802.11a 6Mbps	Bottom Face	13	149	5745	11.1	12	1.230	87.44	1.144	0.19	0.006	0.008
	WLAN 5.8GHz	802.11a 6Mbps	Edge 1	0	149	5745	11.1	12	1.230	87.44	1.144	0.18	0.178	0.251
12	WLAN 5.8GHz	802.11a 6Mbps	Edge 4	0	149	5745	11.1	12	1.230	87.44	1.144	0.08	0.404	0.569
	WLAN 5.8GHz	802.11a 6Mbps	Bottom Face	0	149	5745	11.1	12	1.230	87.44	1.144	0.13	0.247	0.348
	WLAN 5.8GHz	802.11a 6Mbps	Curved Edge4	0	149	5745	11.1	12	1.230	87.44	1.144	0.09	0.368	0.518



**15.2 Repeated SAR Measurement**

Plot No.	Band	BW (MHz)	Modulation	RB Size	RB Offset	Mode	Test Position	Gap (mm)	Power Reduction	Ch.	Freq. (MHz)	Average Power (dBm)	Tune-Up Limit (dBm)	Scaling Factor	Power Drift (dB)	Measured 1g SAR (W/kg)	Ratio	Reported 1g SAR (W/kg)
1st	WCDMA Band V	-	-	-	-	RMC 12.2Kbps	Bottom Face	0	ON	4233	846.6	20.23	20.5	1.064	0.14	1.070	1	1.139
2nd	WCDMA Band V	-	-	-	-	RMC 12.2Kbps	Bottom Face	0	ON	4233	846.6	20.23	20.5	1.064	0.08	1.030	1.039	1.096
1st	WCDMA Band II	-	-	-	-	RMC 12.2Kbps	Bottom Face	13	OFF	9538	1907.6	23.22	23.5	1.067	0.06	1.100	1	1.173
2nd	WCDMA Band II	-	-	-	-	RMC 12.2Kbps	Bottom Face	13	OFF	9538	1907.6	23.22	23.5	1.067	0.04	1.050	1.048	1.120
1st	LTE Band 12	10M	QPSK	25RB	0Offset	-	Bottom Face	0	ON	23095	707.5	21.4	21.5	1.023	0.08	1.120	1	1.146
2nd	LTE Band 12	10M	QPSK	25RB	0Offset	-	Bottom Face	0	ON	23095	707.5	21.4	21.5	1.023	-0.02	1.080	1.037	1.105
1st	LTE Band 4	20M	QPSK	100RB	0Offset	-	Edge 2	0	ON	20175	1732.5	14.97	15.5	1.130	0.14	1.060	1	1.198
2nd	LTE Band 4	20M	QPSK	100RB	0Offset	-	Edge 2	0	ON	20175	1732.5	14.97	15.5	1.130	0.03	1.010	1.050	1.141
1st	LTE Band 30	10M	QPSK	1RB	25Offset	-	Bottom Face	0	ON	27710	2310	15.79	16	1.050	-0.09	1.140	1	1.196
2nd	LTE Band 30	10M	QPSK	1RB	25Offset	-	Bottom Face	0	ON	27710	2310	15.79	16	1.050	-0.11	1.110	1.027	1.165
1st	LTE Band 7	20M	QPSK	1RB	49Offset	-	Bottom Face	13	OFF	20850	2510	22.92	23.5	1.143	-0.07	0.993	1	1.135
2nd	LTE Band 7	20M	QPSK	1RB	49Offset	-	Bottom Face	13	OFF	20850	2510	22.92	23.5	1.143	-0.03	0.989	1.004	1.130

**General Note:**

1. Per KDB 865664 D01v01r04, for each frequency band, repeated SAR measurement is required only when the measured SAR is  $\geq 0.8W/kg$ .
2. Per KDB 865664 D01v01r04, if the ratio among the repeated measurement is  $\leq 1.2$  and the measured SAR  $< 1.45W/kg$ , only one repeated measurement is required.
3. The ratio is the difference in percentage between original and repeated *measured SAR*.
4. All measurement SAR result is scaled-up to account for tune-up tolerance and is compliant.

**16. Simultaneous Transmission Analysis**

NO.	Simultaneous Transmission Configurations	Tablet
		Body
1.	WCDMA + WLAN2.4GHz	Yes
2.	LTE + WLAN2.4GHz	Yes
3.	WCDMA+ Bluetooth	Yes
4.	LTE + Bluetooth	Yes
5.	WCDMA + WLAN5GHz	Yes
6.	LTE + WLAN5GHz	Yes

**General Note:**

1. EUT will choose each WCDMA and LTE according to the network signal condition; therefore, they will not operate simultaneously at any moment.
2. WLAN and Bluetooth share the same antenna, and cannot transmit simultaneously.
3. EUT will choose either WLAN 2.4GHz or WLAN 5GHz according to the network signal condition; therefore, 2.4GHz WLAN and 5GHz WLAN will not operate simultaneously at any moment.
4. Chose the worst SAR of all WLAN 5GHz together correspondently test position for co-located with WWAN analysis.
5. The Scaled SAR summation is calculated based on the same configuration and test position.
6. Per KDB 447498 D01v06, simultaneous transmission SAR is compliant if,
  - i) Scalar SAR summation < 1.6W/kg.
  - ii)  $SPLSR = (SAR1 + SAR2)^{1.5} / (\text{min. separation distance, mm})$ , and the peak separation distance is determined from the square root of  $[(x1-x2)^2 + (y1-y2)^2 + (z1-z2)^2]$ , where (x1, y1, z1) and (x2, y2, z2) are the coordinates of the extrapolated peak SAR locations in the zoom scan.
  - iii) If  $SPLSR \leq 0.04$ , simultaneously transmission SAR measurement is not necessary.
  - iv) Simultaneously transmission SAR measurement, and the reported multi-band SAR < 1.6W/kg.
  - v) The SPLSR calculated results please refer to section 16.2.
7. For simultaneous transmission analysis, Bluetooth SAR is estimated per KDB 447498 D01v06 based on the formula below.
  - i)  $(\text{max. power of channel, including tune-up tolerance, mW}) / (\text{min. test separation distance, mm}) \cdot [\sqrt{f(\text{GHz})} / x] \text{ W/kg}$  for test separation distances  $\leq 50 \text{ mm}$ ; where  $x = 7.5$  for 1-g SAR, and  $x = 18.75$  for 10-g SAR.
  - ii) When the minimum separation distance is < 5mm, the distance is used 5mm to determine SAR test exclusion.
  - iii) 0.4 W/kg for 1-g SAR and 1.0 W/kg for 10-g SAR, when the test separation distances is > 50 mm.
  - iv) Bluetooth estimated SAR is conservatively determined by 5mm separation, for all applicable exposure positions.

Bluetooth Max Power	Exposure Position	All Positions
7.0 dBm	Estimated SAR (W/kg)	0.210 W/kg



16.1 Body Exposure Conditions

WWAN Band		Exposure Position	1	2	1+2 Summed 1g SAR (W/kg)	SPLSR	Case No
			WWAN	2.4GHz WLAN			
			1g SAR (W/kg)	1g SAR (W/kg)			
WCDMA	Band V	Bottom Face at 13mm	0.377	0.039	0.42		
		Edge 2 at 18mm	0.139		0.14		
		Bottom Face at 0mm	1.139	0.532	<b>1.67</b>	<b>0.01</b>	<b>01</b>
		Edge 1 at 0mm	0.174	0.233	0.41		
		Edge 2 at 0mm	0.641		0.64		
		Edge 4 at 0mm		0.322	0.32		
		Curved Edge2	0.787		0.79		
		Curved Edge4		0.250	0.25		
	Band IV	Bottom Face at 13mm	0.724	0.039	0.76		
		Edge 2 at 18mm	0.572		0.57		
		Bottom Face at 0mm	0.647	0.532	1.18		
		Edge 1 at 0mm	0.536	0.233	0.77		
		Edge 2 at 0mm	1.145		1.15		
		Edge 4 at 0mm		0.322	0.32		
		Curved Edge2	1.173		1.17		
		Curved Edge4		0.250	0.25		
	Band II	Bottom Face at 13mm	1.173	0.039	1.21		
		Edge 2 at 18mm	1.067		1.07		
		Bottom Face at 0mm	0.784	0.532	1.32		
		Edge 1 at 0mm	0.347	0.233	0.58		
		Edge 2 at 0mm	0.845		0.85		
		Edge 4 at 0mm		0.322	0.32		
		Curved Edge2	1.125		1.13		
		Curved Edge4		0.250	0.25		



WWAN Band		Exposure Position	1	2	1+2 Summed 1g SAR (W/kg)	SPLSR	Case No
			WWAN	2.4GHz WLAN			
			1g SAR (W/kg)	1g SAR (W/kg)			
LTE	Band 12	Bottom Face at 13mm	0.371	0.039	0.41		
		Edge 2 at 18mm	0.174		0.17		
		Bottom Face at 0mm	1.146	0.532	<b>1.68</b>	<b>0.01</b>	<b>02</b>
		Edge 1 at 0mm	0.187	0.233	0.42		
		Edge 2 at 0mm	0.619		0.62		
		Edge 4 at 0mm		0.322	0.32		
		Curved Edge2	0.872		0.87		
		Curved Edge4		0.250	0.25		
	Band 5	Bottom Face at 13mm	0.343	0.039	0.38		
		Edge 2 at 18mm	0.126		0.13		
		Bottom Face at 0mm	1.107	0.532	<b>1.64</b>	<b>0.01</b>	<b>03</b>
		Edge 1 at 0mm	0.167	0.233	0.40		
		Edge 2 at 0mm	1.195		1.20		
		Edge 4 at 0mm		0.322	0.32		
		Curved Edge2	0.806		0.81		
		Curved Edge4		0.250	0.25		
	Band 4	Bottom Face at 13mm	0.611	0.039	0.65		
		Edge 2 at 18mm	0.475		0.48		
		Bottom Face at 0mm	0.612	0.532	1.14		
		Edge 1 at 0mm	0.481	0.233	0.71		
		Edge 2 at 0mm	1.198		1.20		
		Edge 4 at 0mm		0.322	0.32		
		Curved Edge2	1.028		1.03		
		Curved Edge4		0.250	0.25		
	Band 2	Bottom Face at 13mm	1.104	0.039	1.14		
		Edge 2 at 18mm	0.788		0.79		
		Bottom Face at 0mm	0.728	0.532	1.26		
		Edge 1 at 0mm	0.337	0.233	0.57		
Edge 2 at 0mm		1.006		1.01			
Edge 4 at 0mm			0.322	0.32			
Curved Edge2		1.187		1.19			
Curved Edge4			0.250	0.25			



WWAN Band		Exposure Position	1	2	1+2 Summed 1g SAR (W/kg)	SPLSR	Case No
			WWAN	2.4GHz WLAN			
			1g SAR (W/kg)	1g SAR (W/kg)			
LTE	Band 30	Bottom Face at 13mm	0.774	0.039	0.81		
		Edge 2 at 18mm	0.597		0.60		
		Bottom Face at 0mm	1.196	0.532	<b>1.73</b>	<b>0.01</b>	<b>04</b>
		Edge 1 at 0mm	1.051	0.233	1.28		
		Edge 2 at 0mm	0.614		0.61		
		Edge 4 at 0mm		0.322	0.32		
		Curved Edge2	0.719		0.72		
		Curved Edge4		0.250	0.25		
	Band 7	Bottom Face at 13mm	1.135	0.039	1.17		
		Edge 2 at 18mm	0.392		0.39		
		Bottom Face at 0mm	1.053	0.532	<b>1.59</b>		
		Edge 1 at 0mm	0.993	0.233	1.23		
		Edge 2 at 0mm	0.372		0.37		
		Edge 4 at 0mm		0.322	0.32		
		Curved Edge2	0.571		0.57		
Curved Edge4		0.250	0.25				



WWAN Band		Exposure Position	1	3	1+3 Summed 1g SAR (W/kg)	SPLSR	Case No
			WWAN	5GHz WLAN			
			1g SAR (W/kg)	1g SAR (W/kg)			
WCDMA	Band V	Bottom Face at 13mm	0.377	0.024	0.40		
		Edge 2 at 18mm	0.139		0.14		
		Bottom Face at 0mm	1.139	0.666	<b>1.81</b>	<b>0.01</b>	<b>05</b>
		Edge 1 at 0mm	0.174	0.262	0.44		
		Edge 2 at 0mm	0.641		0.64		
		Edge 4 at 0mm		0.569	0.57		
		Curved Edge2	0.787		0.79		
		Curved Edge4		0.518	0.52		
	Band IV	Bottom Face at 13mm	0.724	0.024	0.75		
		Edge 2 at 18mm	0.572		0.57		
		Bottom Face at 0mm	0.647	0.666	1.31		
		Edge 1 at 0mm	0.536	0.262	0.80		
		Edge 2 at 0mm	1.145		1.15		
		Edge 4 at 0mm		0.569	0.57		
		Curved Edge2	1.173		1.17		
		Curved Edge4		0.518	0.52		
	Band II	Bottom Face at 13mm	1.173	0.024	1.20		
		Edge 2 at 18mm	1.067		1.07		
		Bottom Face at 0mm	0.784	0.666	<b>1.45</b>		
		Edge 1 at 0mm	0.347	0.262	0.61		
		Edge 2 at 0mm	0.845		0.85		
		Edge 4 at 0mm		0.569	0.57		
		Curved Edge2	1.125		1.13		
		Curved Edge4		0.518	0.52		



WWAN Band		Exposure Position	1	3	1+3 Summed 1g SAR (W/kg)	SPLSR	Case No
			WWAN	5GHz WLAN			
			1g SAR (W/kg)	1g SAR (W/kg)			
LTE	Band 12	Bottom Face at 13mm	0.371	0.024	0.40		
		Edge 2 at 18mm	0.174		0.17		
		Bottom Face at 0mm	1.146	0.666	<b>1.81</b>	<b>0.01</b>	<b>06</b>
		Edge 1 at 0mm	0.187	0.262	0.45		
		Edge 2 at 0mm	0.619		0.62		
		Edge 4 at 0mm		0.569	0.57		
		Curved Edge2	0.872		0.87		
		Curved Edge4		0.518	0.52		
	Band 5	Bottom Face at 13mm	0.343	0.024	0.37		
		Edge 2 at 18mm	0.126		0.13		
		Bottom Face at 0mm	1.107	0.666	<b>1.77</b>	<b>0.01</b>	<b>07</b>
		Edge 1 at 0mm	0.167	0.262	0.43		
		Edge 2 at 0mm	1.195		1.20		
		Edge 4 at 0mm		0.569	0.57		
		Curved Edge2	0.806		0.81		
		Curved Edge4		0.518	0.52		
	Band 4	Bottom Face at 13mm	0.611	0.024	0.64		
		Edge 2 at 18mm	0.475		0.48		
		Bottom Face at 0mm	0.612	0.666	1.28		
		Edge 1 at 0mm	0.481	0.262	0.74		
		Edge 2 at 0mm	1.198		1.20		
		Edge 4 at 0mm		0.569	0.57		
		Curved Edge2	1.028		1.03		
		Curved Edge4		0.518	0.52		
	Band 2	Bottom Face at 13mm	1.104	0.024	1.13		
		Edge 2 at 18mm	0.788		0.79		
		Bottom Face at 0mm	0.728	0.666	1.39		
		Edge 1 at 0mm	0.337	0.262	0.60		
Edge 2 at 0mm		1.006		1.01			
Edge 4 at 0mm			0.569	0.57			
Curved Edge2		1.187		1.19			
Curved Edge4			0.518	0.52			

WWAN Band		Exposure Position	1	3	1+3 Summed 1g SAR (W/kg)	SPLSR	Case No
			WWAN	5GHz WLAN			
			1g SAR (W/kg)	1g SAR (W/kg)			
LTE	Band 30	Bottom Face at 13mm	0.774	0.024	0.80		
		Edge 2 at 18mm	0.597		0.60		
		Bottom Face at 0mm	1.196	0.666	<b>1.86</b>	<b>0.01</b>	<b>08</b>
		Edge 1 at 0mm	1.051	0.262	1.31		
		Edge 2 at 0mm	0.614		0.61		
		Edge 4 at 0mm		0.569	0.57		
		Curved Edge2	0.719		0.72		
		Curved Edge4		0.518	0.52		
	Band 7	Bottom Face at 13mm	1.135	0.024	1.16		
		Edge 2 at 18mm	0.392		0.39		
		Bottom Face at 0mm	1.053	0.666	<b>1.72</b>	<b>0.01</b>	<b>09</b>
		Edge 1 at 0mm	0.993	0.262	1.26		
		Edge 2 at 0mm	0.372		0.37		
		Edge 4 at 0mm		0.569	0.57		
		Curved Edge2	0.571		0.57		
Curved Edge4		0.518	0.52				



WWAN Band		Exposure Position	1	4	1+4 Summed 1g SAR (W/kg)	SPLSR	Case No
			WWAN	Bluetooth			
			1g SAR (W/kg)	Estimated 1g SAR (W/kg)			
WCDMA	Band V	Bottom Face at 13mm	0.377	0.210	0.59		
		Edge 2 at 18mm	0.139		0.14		
		Bottom Face at 0mm	1.139	0.210	1.35		
		Edge 1 at 0mm	0.174	0.210	0.38		
		Edge 2 at 0mm	0.641		0.64		
		Edge 4 at 0mm		0.210	0.21		
		Curved Edge2	0.787		0.79		
		Curved Edge4		0.210	0.21		
	Band IV	Bottom Face at 13mm	0.724	0.210	0.93		
		Edge 2 at 18mm	0.572		0.57		
		Bottom Face at 0mm	0.647	0.210	0.86		
		Edge 1 at 0mm	0.536	0.210	0.75		
		Edge 2 at 0mm	1.145		1.15		
		Edge 4 at 0mm		0.210	0.21		
		Curved Edge2	1.173		1.17		
		Curved Edge4		0.210	0.21		
	Band II	Bottom Face at 13mm	1.173	0.210	1.38		
		Edge 2 at 18mm	1.067		1.07		
		Bottom Face at 0mm	0.784	0.210	0.99		
		Edge 1 at 0mm	0.347	0.210	0.56		
		Edge 2 at 0mm	0.845		0.85		
		Edge 4 at 0mm		0.210	0.21		
		Curved Edge2	1.125		1.13		
		Curved Edge4		0.210	0.21		



WWAN Band		Exposure Position	1	4	1+4 Summed 1g SAR (W/kg)	SPLSR	Case No
			WWAN	Bluetooth			
			1g SAR (W/kg)	Estimated 1g SAR (W/kg)			
LTE	Band 12	Bottom Face at 13mm	0.371	0.210	0.58		
		Edge 2 at 18mm	0.174		0.17		
		Bottom Face at 0mm	1.146	0.210	1.36		
		Edge 1 at 0mm	0.187	0.210	0.40		
		Edge 2 at 0mm	0.619		0.62		
		Edge 4 at 0mm		0.210	0.21		
		Curved Edge2	0.872		0.87		
	Curved Edge4		0.210	0.21			
	Band 5	Bottom Face at 13mm	0.343	0.210	0.55		
		Edge 2 at 18mm	0.126		0.13		
		Bottom Face at 0mm	1.107	0.210	1.32		
		Edge 1 at 0mm	0.167	0.210	0.38		
		Edge 2 at 0mm	1.195		1.20		
		Edge 4 at 0mm		0.210	0.21		
		Curved Edge2	0.806		0.81		
	Curved Edge4		0.210	0.21			
	Band 4	Bottom Face at 13mm	0.611	0.210	0.82		
		Edge 2 at 18mm	0.475		0.48		
		Bottom Face at 0mm	0.612	0.210	0.82		
		Edge 1 at 0mm	0.481	0.210	0.69		
		Edge 2 at 0mm	1.198		1.20		
		Edge 4 at 0mm		0.210	0.21		
		Curved Edge2	1.028		1.03		
	Curved Edge4		0.210	0.21			
	Band 2	Bottom Face at 13mm	1.104	0.210	1.31		
		Edge 2 at 18mm	0.788		0.79		
		Bottom Face at 0mm	0.728	0.210	0.94		
		Edge 1 at 0mm	0.337	0.210	0.55		
Edge 2 at 0mm		1.006		1.01			
Edge 4 at 0mm			0.210	0.21			
Curved Edge2		1.187		1.19			
Curved Edge4		0.210	0.21				



WWAN Band		Exposure Position	1	4	1+4 Summed 1g SAR (W/kg)	SPLSR	Case No
			WWAN	Bluetooth			
			1g SAR (W/kg)	Estimated 1g SAR (W/kg)			
LTE	Band 30	Bottom Face at 13mm	0.774	0.210	0.98		
		Edge 2 at 18mm	0.597		0.60		
		Bottom Face at 0mm	1.196	0.210	1.41		
		Edge 1 at 0mm	1.051	0.210	1.26		
		Edge 2 at 0mm	0.614		0.61		
		Edge 4 at 0mm		0.210	0.21		
		Curved Edge2	0.719		0.72		
	Curved Edge4		0.210	0.21			
	Band 7	Bottom Face at 13mm	1.135	0.210	1.35		
		Edge 2 at 18mm	0.392		0.39		
		Bottom Face at 0mm	1.053	0.210	1.26		
		Edge 1 at 0mm	0.993	0.210	1.20		
		Edge 2 at 0mm	0.372		0.37		
		Edge 4 at 0mm		0.210	0.21		
Curved Edge2		0.571		0.57			
Curved Edge4		0.210	0.21				

**16.2 SPLSR Evaluation and Analysis**

**General Note:**

$SPLSR = (SAR_1 + SAR_2)^{1.5} / (min. \text{ separation distance, mm})$ . If  $SPLSR \leq 0.04$ , simultaneously transmission SAR measurement is not necessary.

Case	Band	Position	SAR (W/kg)	Gap (mm)	SAR peak location (m)			3D distance (mm)	Summed SAR (W/kg)	SPLSR Results	Simultaneous SAR
					X	Y	Z				
01	WCDMA Band V	Bottom Face	1.139	0	0.0215	0.134	-0.178	259.1	1.67	0.01	Not required
	WLAN 2.4GHz		0.532	0	0.0676	-0.121	-0.178				

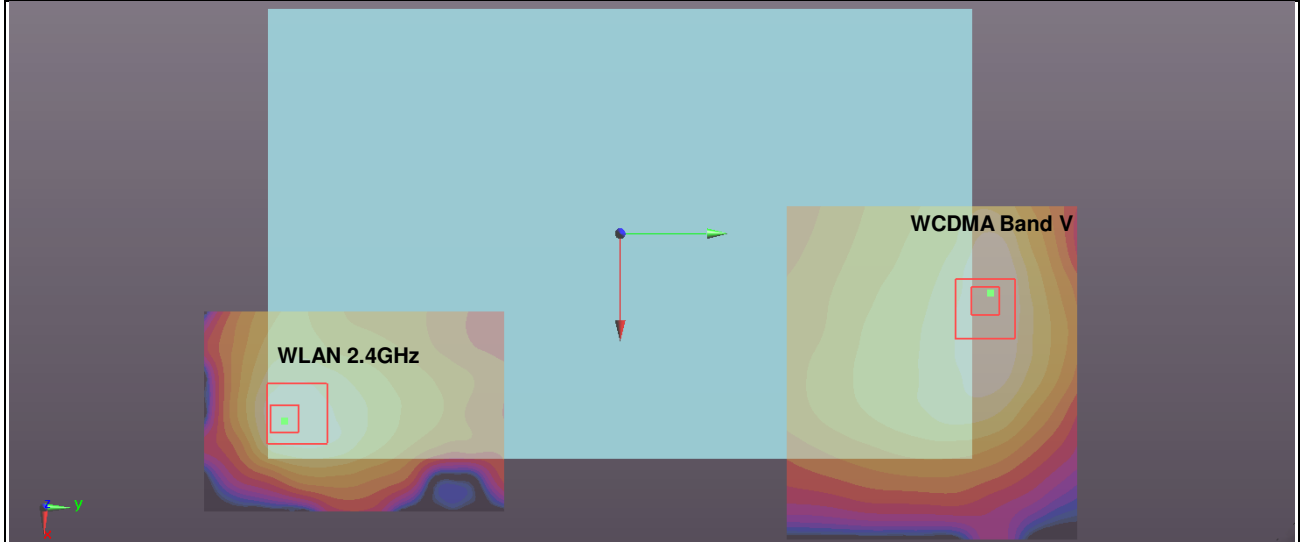

Case	Band	Position	SAR (W/kg)	Gap (mm)	SAR peak location (m)			3D distance (mm)	Summed SAR (W/kg)	SPLSR Results	Simultaneous SAR
					X	Y	Z				
02	LTE Band12	Bottom Face	1.146	0	0.0235	0.132	-0.178	256.8	1.68	0.01	Not required
	WLAN2.4GHz		0.532	0	0.0676	-0.121	-0.178				

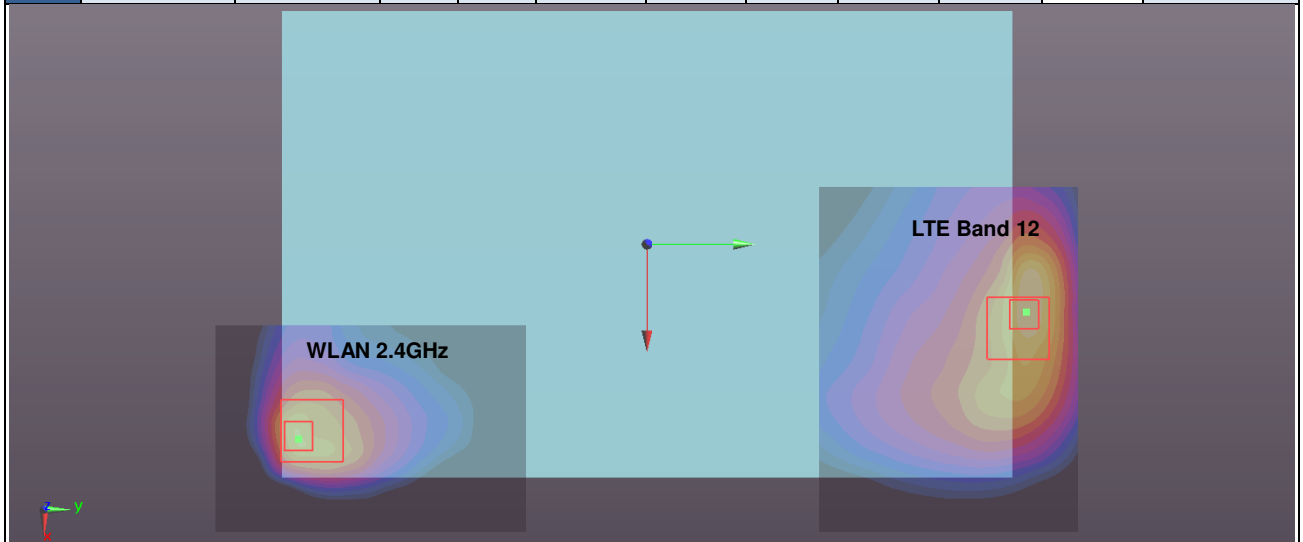

Case	Band	Position	SAR (W/kg)	Gap (mm)	SAR peak location (m)			3D distance (mm)	Summed SAR (W/kg)	SPLSR Results	Simultaneous SAR
					X	Y	Z				
03	LTE Band 5	Bottom Face	1.107	0	0.029	0.122	-0.178	246.0	1.64	0.01	Not required
	WLAN2.4GHz		0.532	0	0.0676	-0.121	-0.178				

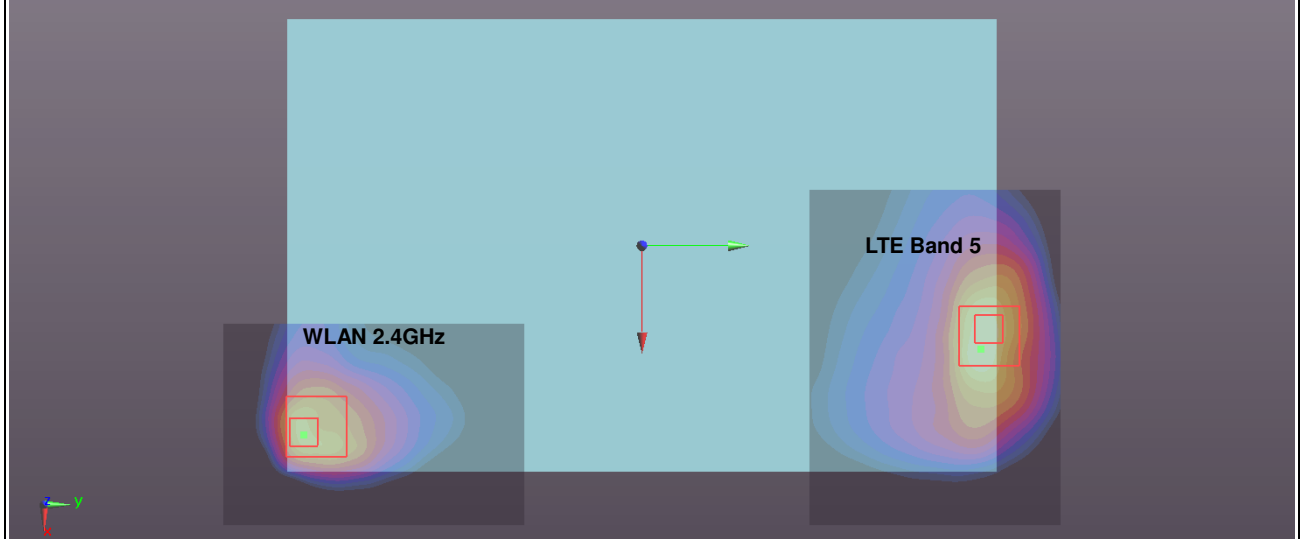

Case	Band	Position	SAR (W/kg)	Gap (mm)	SAR peak location (m)			3D distance (mm)	Summed SAR (W/kg)	SPLSR Results	Simultaneous SAR
					X	Y	Z				
04	LTE Band 30	Bottom Face	1.196	0	0.048	0.132	-0.178	253.8	1.73	0.01	Not required
	WLAN2.4GHz		0.532	0	0.0676	-0.121	-0.178				

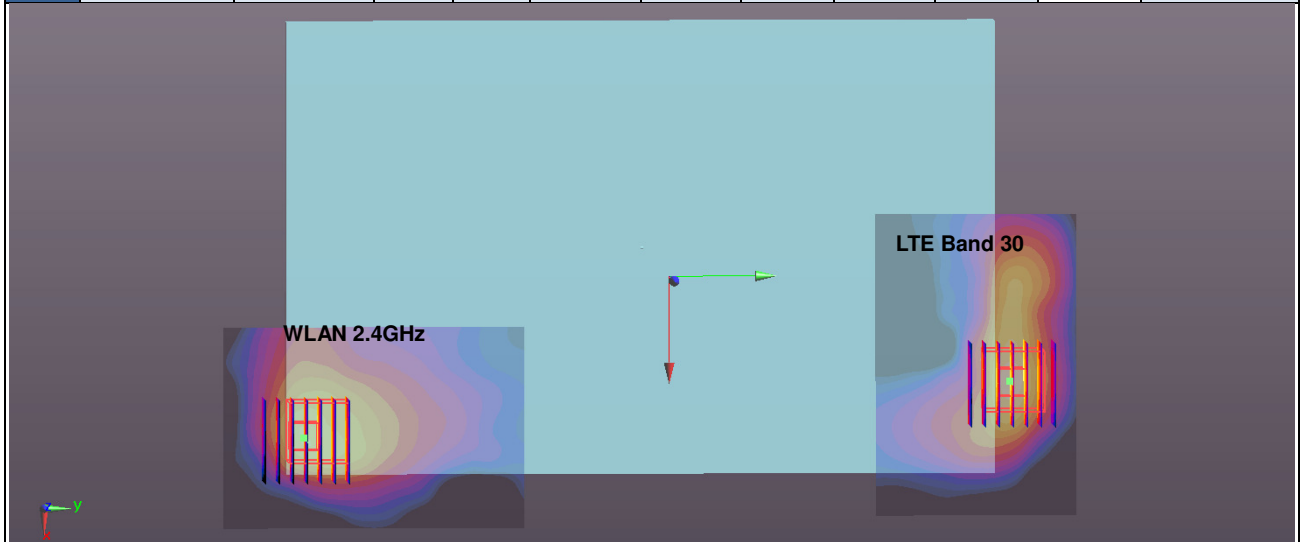

Case	Band	Position	SAR (W/kg)	Gap (mm)	SAR peak location (m)			3D distance (mm)	Summed SAR (W/kg)	SPLSR Results	Simultaneous SAR
					X	Y	Z				
05	WCDMA Band V	Bottom Face	1.139	0	0.0215	0.134	-0.178	252.6	1.81	0.01	Not required
	WLAN5GHz		0.666	0	0.064	-0.115	-0.178				

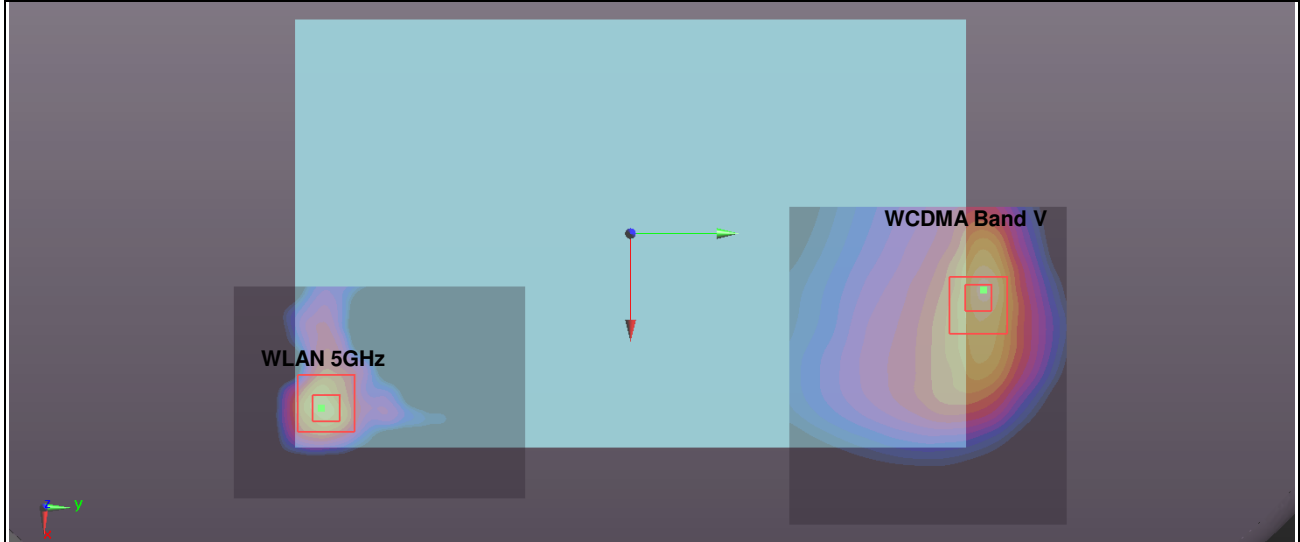

Case	Band	Position	SAR (W/kg)	Gap (mm)	SAR peak location (m)			3D distance (mm)	Summed SAR (W/kg)	SPLSR Results	Simultaneous SAR
					X	Y	Z				
06	LTE Band 12	Bottom Face	1.146	0	0.0235	0.132	-0.178	250.3	1.81	0.01	Not required
	WLAN5GHz		0.666	0	0.064	-0.115	-0.178				

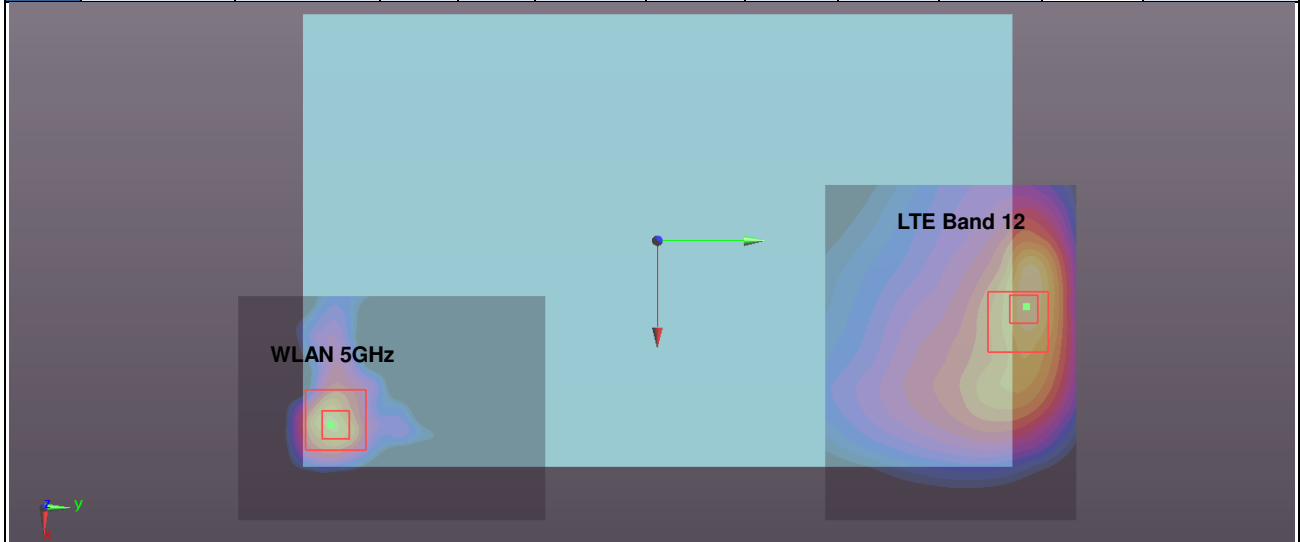

Case 07	Band	Position	SAR (W/kg)	Gap (mm)	SAR peak location (m)			3D distance (mm)	Summed SAR (W/kg)	SPLSR Results	Simultaneous SAR
					X	Y	Z				
	LTE Band 5	Bottom Face	1.107	0	0.029	0.122	-0.178	239.6	1.77	0.01	Not required
	WLAN5GHz		0.666	0	0.064	-0.115	-0.178				

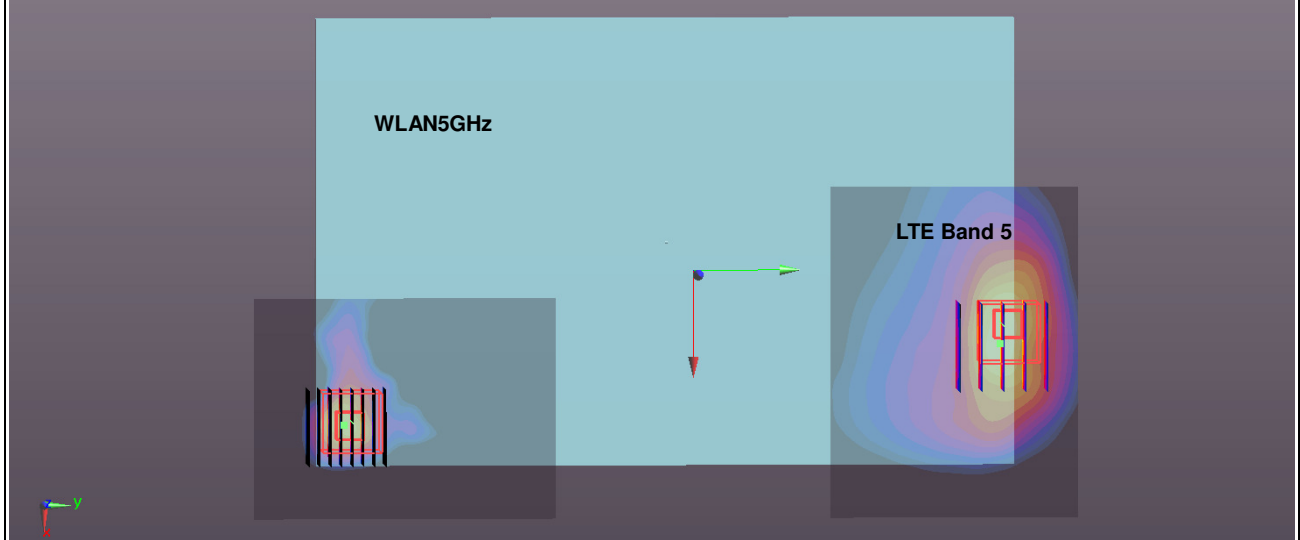

Case 08	Band	Position	SAR (W/kg)	Gap (mm)	SAR peak location (m)			3D distance (mm)	Summed SAR (W/kg)	SPLSR Results	Simultaneous SAR
					X	Y	Z				
	LTE Band 30	Bottom Face	1.196	0	0.048	0.132	-0.178	247.5	1.86	0.01	Not required
	WLAN5GHz		0.666	0	0.064	-0.115	-0.178				

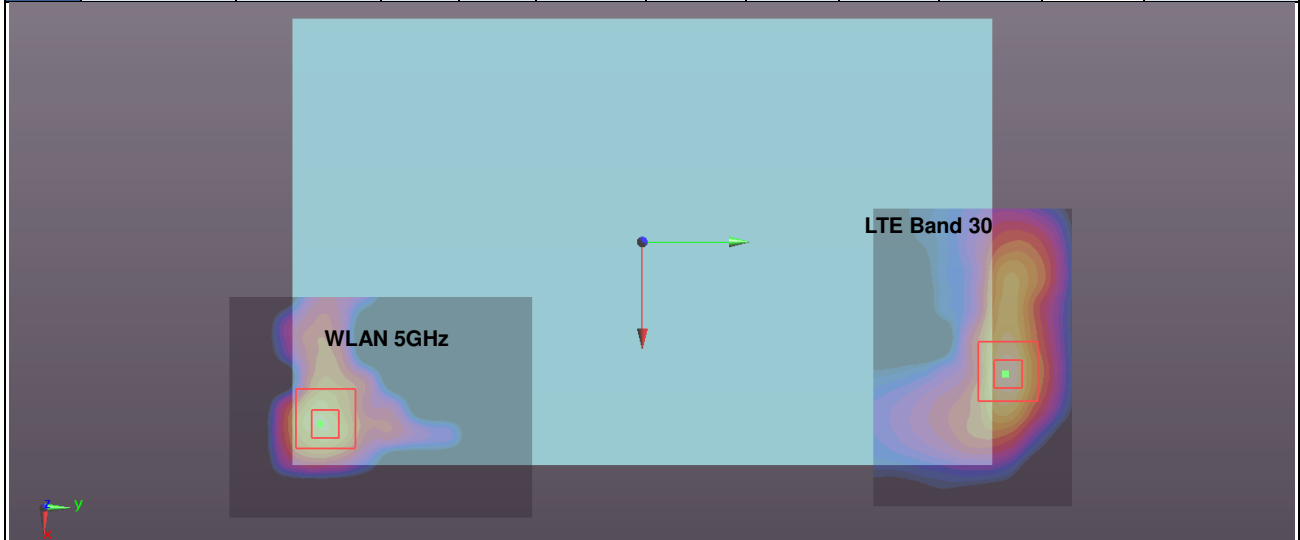

Case 09	Band	Position	SAR (W/kg)	Gap (mm)	SAR peak location (m)			3D distance (mm)	Summed SAR (W/kg)	SPLSR Results	Simultaneous SAR
					X	Y	Z				
	LTE Band 7	Bottom Face	1.053	0	0.0456	0.132	-0.177	247.7	1.72	0.01	Not required
	WLAN5GHz		0.666	0	0.064	-0.115	-0.178				

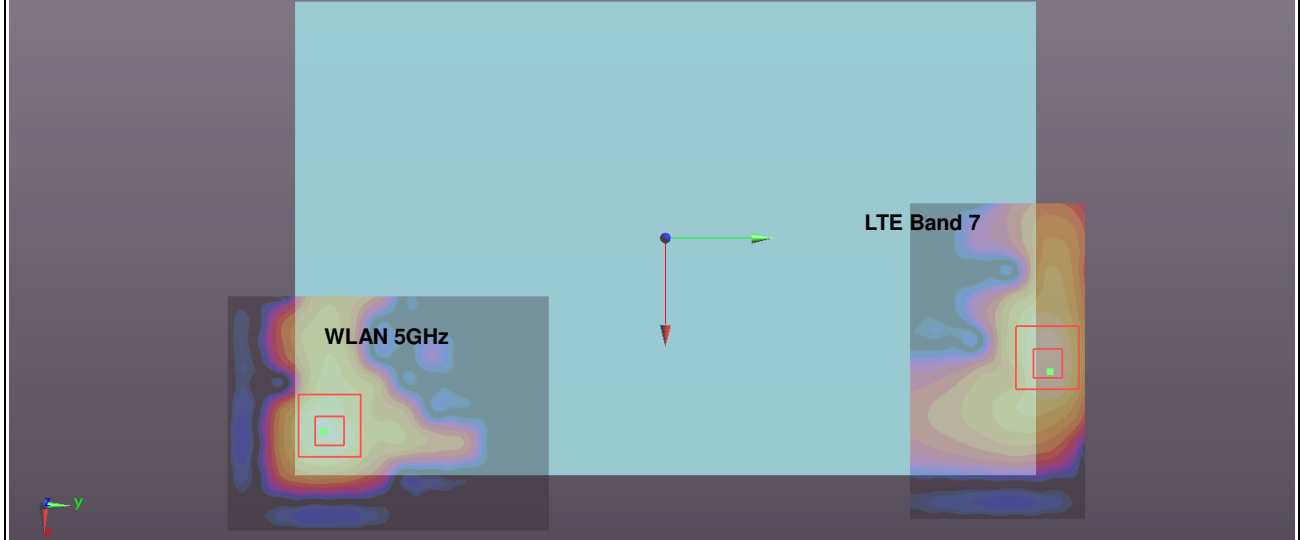

**Test Engineer :** Nick Hu

## **17. Uncertainty Assessment**

The component of uncertainty may generally be categorized according to the methods used to evaluate them. The evaluation of uncertainty by the statistical analysis of a series of observations is termed a Type A evaluation of uncertainty. The evaluation of uncertainty by means other than the statistical analysis of a series of observation is termed a Type B evaluation of uncertainty. Each component of uncertainty, however evaluated, is represented by an estimated standard deviation, termed standard uncertainty, which is determined by the positive square root of the estimated variance.

A Type A evaluation of standard uncertainty may be based on any valid statistical method for treating data. This includes calculating the standard deviation of the mean of a series of independent observations; using the method of least squares to fit a curve to the data in order to estimate the parameter of the curve and their standard deviations; or carrying out an analysis of variance in order to identify and quantify random effects in certain kinds of measurement.

A type B evaluation of standard uncertainty is typically based on scientific judgment using all of the relevant information available. These may include previous measurement data, experience, and knowledge of the behavior and properties of relevant materials and instruments, manufacture’s specification, data provided in calibration reports and uncertainties assigned to reference data taken from handbooks. Broadly speaking, the uncertainty is either obtained from an outdoor source or obtained from an assumed distribution, such as the normal distribution, rectangular or triangular distributions indicated in table below.

<b>Uncertainty Distributions</b>	<b>Normal</b>	<b>Rectangular</b>	<b>Triangular</b>	<b>U-Shape</b>
Multi-plying Factor <sup>(a)</sup>	1/ $\kappa$ <sup>(b)</sup>	1/ $\sqrt{3}$	1/ $\sqrt{6}$	1/ $\sqrt{2}$

(a) standard uncertainty is determined as the product of the multiplying factor and the estimated range of variations in the measured quantity

(b)  $\kappa$  is the coverage factor

**Table 17.1. Standard Uncertainty for Assumed Distribution**

The combined standard uncertainty of the measurement result represents the estimated standard deviation of the result. It is obtained by combining the individual standard uncertainties of both Type A and Type B evaluation using the usual “root-sum-squares” (RSS) methods of combining standard deviations by taking the positive square root of the estimated variances.

Expanded uncertainty is a measure of uncertainty that defines an interval about the measurement result within which the measured value is confidently believed to lie. It is obtained by multiplying the combined standard uncertainty by a coverage factor. Typically, the coverage factor ranges from 2 to 3. Using a coverage factor allows the true value of a measured quantity to be specified with a defined probability within the specified uncertainty range. For purpose of this document, a coverage factor two is used, which corresponds to confidence interval of about 95 %. The DASY uncertainty Budget is shown in the following tables.

Error Description	Uncertainty Value (±%)	Probability	Divisor	(Ci) 1g	(Ci) 10g	Standard Uncertainty (1g) (±%)	Standard Uncertainty (10g) (±%)
<b>Measurement System</b>							
Probe Calibration	6.0	N	1	1	1	6.0	6.0
Axial Isotropy	4.7	R	1.732	0.7	0.7	1.9	1.9
Hemispherical Isotropy	9.6	R	1.732	0.7	0.7	3.9	3.9
Boundary Effects	1.0	R	1.732	1	1	0.6	0.6
Linearity	4.7	R	1.732	1	1	2.7	2.7
System Detection Limits	1.0	R	1.732	1	1	0.6	0.6
Modulation Response	3.2	R	1.732	1	1	1.8	1.8
Readout Electronics	0.3	N	1	1	1	0.3	0.3
Response Time	0.0	R	1.732	1	1	0.0	0.0
Integration Time	2.6	R	1.732	1	1	1.5	1.5
RF Ambient Noise	3.0	R	1.732	1	1	1.7	1.7
RF Ambient Reflections	3.0	R	1.732	1	1	1.7	1.7
Probe Positioner	0.4	R	1.732	1	1	0.2	0.2
Probe Positioning	2.9	R	1.732	1	1	1.7	1.7
Max. SAR Eval.	2.0	R	1.732	1	1	1.2	1.2
<b>Test Sample Related</b>							
Device Positioning	3.0	N	1	1	1	3.0	3.0
Device Holder	3.6	N	1	1	1	3.6	3.6
Power Drift	5.0	R	1.732	1	1	2.9	2.9
Power Scaling	0.0	R	1.732	1	1	0.0	0.0
<b>Phantom and Setup</b>							
Phantom Uncertainty	6.1	R	1.732	1	1	3.5	3.5
SAR correction	0.0	R	1.732	1	0.84	0.0	0.0
Liquid Conductivity Repeatability	0.2	N	1	0.78	0.71	0.1	0.1
Liquid Conductivity (target)	5.0	R	1.732	0.78	0.71	2.3	2.0
Liquid Conductivity (mea.)	2.5	R	1.732	0.78	0.71	1.1	1.0
Temp. unc. - Conductivity	3.4	R	1.732	0.78	0.71	1.5	1.4
Liquid Permittivity Repeatability	0.15	N	1	0.23	0.26	0.0	0.0
Liquid Permittivity (target)	5.0	R	1.732	0.23	0.26	0.7	0.8
Liquid Permittivity (mea.)	2.5	R	1.732	0.23	0.26	0.3	0.4
Temp. unc. - Permittivity	0.83	R	1.732	0.23	0.26	0.1	0.1
<b>Combined Std. Uncertainty</b>						11.4%	11.4%
<b>Coverage Factor for 95 %</b>						K=2	K=2
<b>Expanded STD Uncertainty</b>						22.9%	22.7%

**Table 17.2. Uncertainty Budget for frequency range 300 MHz to 3 GHz**



Error Description	Uncertainty Value (±%)	Probability	Divisor	(Ci) 1g	(Ci) 10g	Standard Uncertainty (1g) (±%)	Standard Uncertainty (10g) (±%)
<b>Measurement System</b>							
Probe Calibration	6.55	N	1	1	1	6.6	6.6
Axial Isotropy	4.7	R	1.732	0.7	0.7	1.9	1.9
Hemispherical Isotropy	9.6	R	1.732	0.7	0.7	3.9	3.9
Boundary Effects	2.0	R	1.732	1	1	1.2	1.2
Linearity	4.7	R	1.732	1	1	2.7	2.7
System Detection Limits	1.0	R	1.732	1	1	0.6	0.6
Modulation Response	3.2	R	1.732	1	1	1.8	1.8
Readout Electronics	0.3	N	1	1	1	0.3	0.3
Response Time	0.0	R	1.732	1	1	0.0	0.0
Integration Time	2.6	R	1.732	1	1	1.5	1.5
RF Ambient Noise	3.0	R	1.732	1	1	1.7	1.7
RF Ambient Reflections	3.0	R	1.732	1	1	1.7	1.7
Probe Positioner	0.4	R	1.732	1	1	0.2	0.2
Probe Positioning	6.7	R	1.732	1	1	3.9	3.9
Max. SAR Eval.	4.0	R	1.732	1	1	2.3	2.3
<b>Test Sample Related</b>							
Device Positioning	3.0	N	1	1	1	3.0	3.0
Device Holder	3.6	N	1	1	1	3.6	3.6
Power Drift	5.0	R	1.732	1	1	2.9	2.9
Power Scaling	0.0	R	1.732	1	1	0.0	0.0
<b>Phantom and Setup</b>							
Phantom Uncertainty	6.6	R	1.732	1	1	3.8	3.8
SAR correction	0.0	R	1.732	1	0.84	0.0	0.0
Liquid Conductivity Repeatability	0.2	N	1	0.78	0.71	0.1	0.1
Liquid Conductivity (target)	5.0	R	1.732	0.78	0.71	2.3	2.0
Liquid Conductivity (mea.)	2.5	R	1.732	0.78	0.71	1.1	1.0
Temp. unc. - Conductivity	3.4	R	1.732	0.78	0.71	1.5	1.4
Liquid Permittivity Repeatability	0.15	N	1	0.23	0.26	0.0	0.0
Liquid Permittivity (target)	5.0	R	1.732	0.23	0.26	0.7	0.8
Liquid Permittivity (mea.)	2.5	R	1.732	0.23	0.26	0.3	0.4
Temp. unc. - Permittivity	0.83	R	1.732	0.23	0.26	0.1	0.1
<b>Combined Std. Uncertainty</b>						12.5%	12.5%
<b>Coverage Factor for 95 %</b>						K=2	K=2
<b>Expanded STD Uncertainty</b>						25.1%	25.0%

Table 17.3. Uncertainty Budget for frequency range 3 GHz to 6 GHz



## **18. References**

- [1] FCC 47 CFR Part 2 "Frequency Allocations and Radio Treaty Matters; General Rules and Regulations"
- [2] ANSI/IEEE Std. C95.1-1992, "IEEE Standard for Safety Levels with Respect to Human Exposure to Radio Frequency Electromagnetic Fields, 3 kHz to 300 GHz", September 1992
- [3] IEEE Std. 1528-2013, "IEEE Recommended Practice for Determining the Peak Spatial-Average Specific Absorption Rate (SAR) in the Human Head from Wireless Communications Devices: Measurement Techniques", Sep 2013
- [4] SPEAG DASY System Handbook
- [5] FCC KDB 248227 D01 v02r02, "SAR Guidance for IEEE 802.11 (WiFi) Transmitters", Oct 2015.
- [6] FCC KDB 447498 D01 v06, "Mobile and Portable Device RF Exposure Procedures and Equipment Authorization Policies", Oct 2015
- [7] FCC KDB 941225 D01 v03r01, "3G SAR MEAUREMENT PROCEDURES", Oct 2015
- [8] FCC KDB 941225 D05 v02r05, "SAR Evaluation Considerations for LTE Devices", Dec 2015
- [9] FCC KDB 941225 D05A v01r02, "Rel. 10 LTE SAR Test Guidance and KDB Inquiries", Oct 2015
- [10] FCC KDB 616217 D04 v01r02, "SAR Evaluation Considerations for Laptop, Notebook, Netbook and Tablet Computers", Oct 2015
- [11] FCC KDB 865664 D01 v01r04, "SAR Measurement Requirements for 100 MHz to 6 GHz", Aug 2015.
- [12] FCC KDB 865664 D02 v01r02, "RF Exposure Compliance Reporting and Documentation Considerations" Oct 2015.



## **Appendix A. Plots of System Performance Check**

The plots are shown as follows.

### System Check\_Body\_750MHz

#### DUT: D750V2 - SN:1065

Communication System: UID 0, CW (0); Frequency: 750 MHz; Duty Cycle: 1:1  
Medium: MSL\_750 Medium parameters used:  $f = 750$  MHz;  $\sigma = 0.962$  S/m;  $\epsilon_r = 55.591$ ;  $\rho = 1000$  kg/m<sup>3</sup>  
Ambient Temperature : 23.5 °C ; Liquid Temperature : 22.8 °C

#### DASY5 Configuration:

- Probe: EX3DV4 - SN3857; ConvF(9.45, 9.45, 9.45); Calibrated: 2016.5.25;
- Sensor-Surface: 2mm (Mechanical Surface Detection)
- Electronics: DAE4 Sn1210; Calibrated: 2016.5.18
- Phantom: SAM3; Type: SAM; Serial: TP-1079
- Measurement SW: DASY52, Version 52.8 (8); SEMCAD X Version 14.6.10 (7331)

**Pin=250mW/Area Scan (61x61x1):** Interpolated grid: dx=1.500 mm, dy=1.500 mm  
Maximum value of SAR (interpolated) = 2.76 W/kg

**Pin=250mW/Zoom Scan (5x5x7)/Cube 0:** Measurement grid: dx=8mm, dy=8mm, dz=5mm  
Reference Value = 49.80 V/m; Power Drift = -0.03 dB  
Peak SAR (extrapolated) = 3.22 W/kg  
**SAR(1 g) = 2.18 W/kg; SAR(10 g) = 1.44 W/kg**  
Maximum value of SAR (measured) = 2.76 W/kg

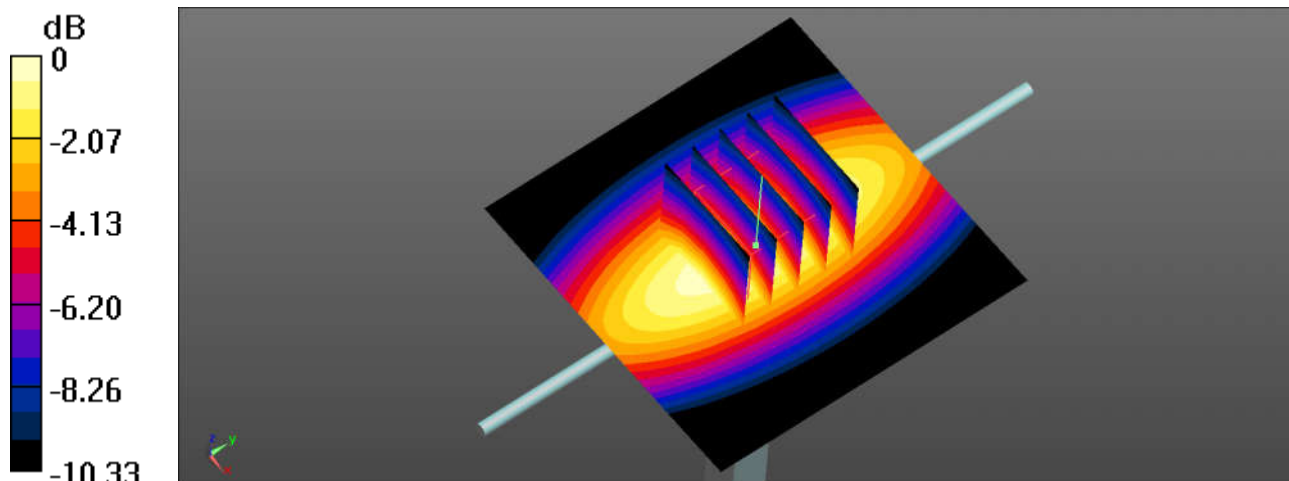

0 dB = 2.76 W/kg = 4.41 dBW/kg

**System Check\_Body\_835MHz**

**DUT: D835V2 - SN:4d091**

Communication System: UID 0, CW; Frequency: 835 MHz; Duty Cycle: 1:1

Medium: MSL\_835 Medium parameters used:  $f = 835 \text{ MHz}$ ;  $\sigma = 0.979 \text{ S/m}$ ;  $\epsilon_r = 54.17$ ;  $\rho = 1000 \text{ kg/m}^3$

Ambient Temperature :  $23.5 \text{ }^\circ\text{C}$  ; Liquid Temperature :  $22.8 \text{ }^\circ\text{C}$

**DASY5 Configuration:**

- Probe: EX3DV4 - SN3857; ConvF(9.25, 9.25, 9.25); Calibrated: 2016.5.25;
- Sensor-Surface: 2mm (Mechanical Surface Detection)
- Electronics: DAE4 Sn1210; Calibrated: 2016.5.18
- Phantom: SAM3; Type: SAM; Serial: TP-1079
- Measurement SW: DASY52, Version 52.8 (8); SEMCAD X Version 14.6.10 (7331)

**Pin=250mW/Area Scan (61x61x1):** Interpolated grid:  $dx=1.500 \text{ mm}$ ,  $dy=1.500 \text{ mm}$

Maximum value of SAR (interpolated) =  $2.86 \text{ W/kg}$

**Pin=250mW/Zoom Scan (5x5x7)/Cube 0:** Measurement grid:  $dx=8\text{mm}$ ,  $dy=8\text{mm}$ ,  $dz=5\text{mm}$

Reference Value =  $50.33 \text{ V/m}$ ; Power Drift =  $-0.03 \text{ dB}$

Peak SAR (extrapolated) =  $3.32 \text{ W/kg}$

**SAR(1 g) =  $2.26 \text{ W/kg}$ ; SAR(10 g) =  $1.5 \text{ W/kg}$**

Maximum value of SAR (measured) =  $2.85 \text{ W/kg}$

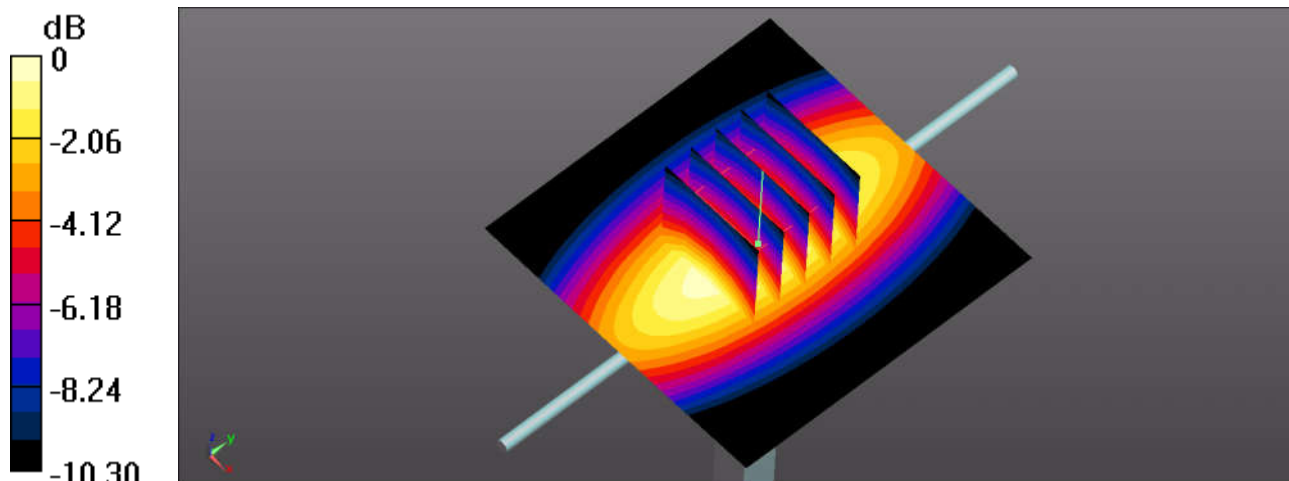

0 dB =  $2.85 \text{ W/kg} = 4.55 \text{ dBW/kg}$

### System Check\_Body\_1750MHz

**DUT: D1750V2 - SN:1069**

Communication System: UID 0, CW; Frequency: 1750 MHz; Duty Cycle: 1:1

Medium: MSL\_1750 Medium parameters used:  $f = 1750$  MHz;  $\sigma = 1.439$  S/m;  $\epsilon_r = 53.02$ ;  $\rho = 1000$  kg/m<sup>3</sup>

Ambient Temperature : 23.4 °C ; Liquid Temperature : 22.7 °C

DASY5 Configuration:

- Probe: EX3DV4 - SN3857; ConvF(7.81, 7.81, 7.81); Calibrated: 2016.5.25;
- Sensor-Surface: 2mm (Mechanical Surface Detection)
- Electronics: DAE4 Sn1210; Calibrated: 2016.5.18
- Phantom: SAM3; Type: SAM; Serial: TP-1079
- Measurement SW: DASY52, Version 52.8 (8); SEMCAD X Version 14.6.10 (7331)

**Pin=250mW/Area Scan (61x61x1):** Interpolated grid: dx=1.500 mm, dy=1.500 mm

Maximum value of SAR (interpolated) = 13.1 W/kg

**Pin=250mW/Zoom Scan (5x5x7)/Cube 0:** Measurement grid: dx=8mm, dy=8mm, dz=5mm

Reference Value = 85.26 V/m; Power Drift = 0.10 dB

Peak SAR (extrapolated) = 16.3 W/kg

**SAR(1 g) = 9.38 W/kg; SAR(10 g) = 4.99 W/kg**

Maximum value of SAR (measured) = 13.2 W/kg

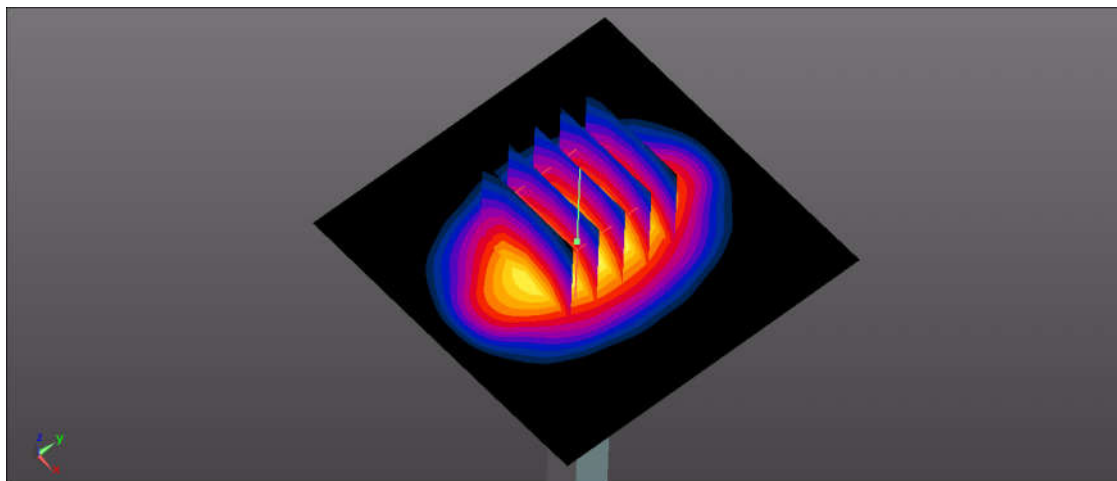
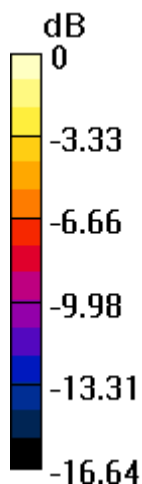

0 dB = 13.2 W/kg = 11.21 dBW/kg

### System Check\_Body\_1900MHz

#### DUT: D1900V2 - SN:5d118

Communication System: UID 0, CW; Frequency: 1900 MHz; Duty Cycle: 1:1

Medium: MSL\_1900 Medium parameters used:  $f = 1900$  MHz;  $\sigma = 1.532$  S/m;  $\epsilon_r = 54.06$ ;  $\rho = 1000$  kg/m<sup>3</sup>

Ambient Temperature : 23.4 °C ; Liquid Temperature : 22.7 °C

#### DASY5 Configuration:

- Probe: EX3DV4 - SN3857; ConvF(7.55, 7.55, 7.55); Calibrated: 2016.5.25;
- Sensor-Surface: 2mm (Mechanical Surface Detection)
- Electronics: DAE4 Sn1210; Calibrated: 2016.5.18
- Phantom: SAM3; Type: SAM; Serial: TP-1079
- Measurement SW: DASY52, Version 52.8 (8); SEMCAD X Version 14.6.10 (7331)

**Pin=250mW/Area Scan (61x61x1):** Interpolated grid: dx=1.500 mm, dy=1.500 mm

Maximum value of SAR (interpolated) = 14.8 W/kg

**Pin=250mW/Zoom Scan (5x5x7)/Cube 0:** Measurement grid: dx=8mm, dy=8mm, dz=5mm

Reference Value = 87.10 V/m; Power Drift = -0.10 dB

Peak SAR (extrapolated) = 18.6 W/kg

**SAR(1 g) = 10.3 W/kg; SAR(10 g) = 5.38 W/kg**

Maximum value of SAR (measured) = 14.8 W/kg

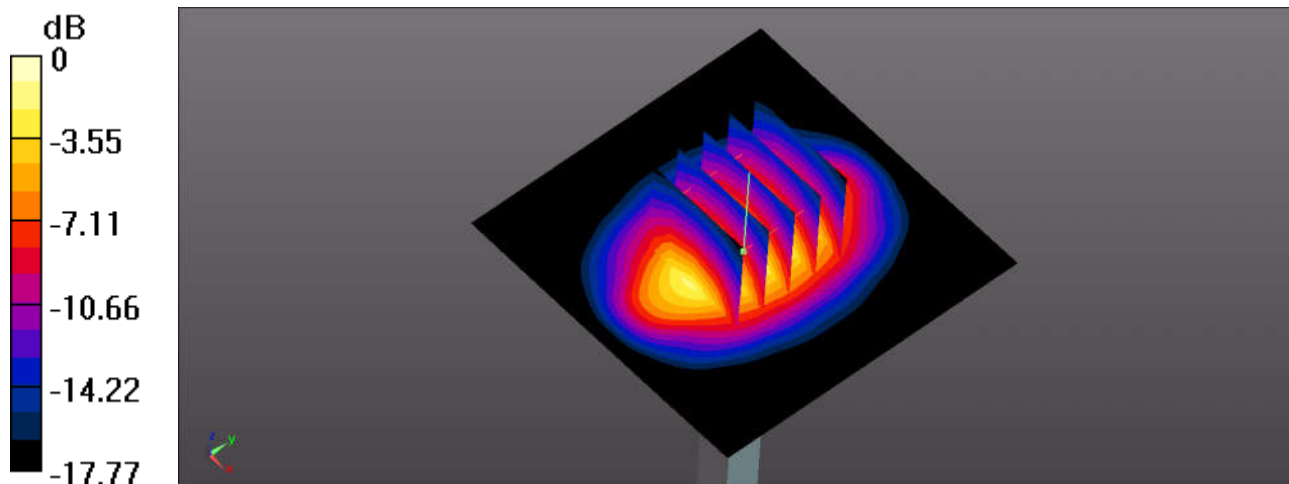

0 dB = 14.8 W/kg = 11.70 dBW/kg

### System Check\_Body\_2300MHz

**DUT: D2300V2 - SN:1055**

Communication System: UID 0, CW (0); Frequency: 2300 MHz; Duty Cycle: 1:1  
Medium: MSL\_2300 Medium parameters used:  $f = 2300$  MHz;  $\sigma = 1.783$  S/m;  $\epsilon_r = 53.164$ ;  $\rho = 1000$  kg/m<sup>3</sup>  
Ambient Temperature : 23.5 °C ; Liquid Temperature : 22.5 °C

DASY5 Configuration:

- Probe: EX3DV4 - SN3857; ConvF(7.31, 7.31, 7.31); Calibrated: 2016.5.25;
- Sensor-Surface: 2mm (Mechanical Surface Detection)
- Electronics: DAE4 Sn1210; Calibrated: 2016.5.18
- Phantom: SAM3; Type: SAM; Serial: TP-1079
- Measurement SW: DASY52, Version 52.8 (8); SEMCAD X Version 14.6.10 (7331)

**Pin=250mW/Area Scan (71x71x1):** Interpolated grid: dx=1.200 mm, dy=1.200 mm  
Maximum value of SAR (interpolated) = 18.9 W/kg

**Pin=250mW/Zoom Scan (7x7x7)/Cube 0:** Measurement grid: dx=5mm, dy=5mm, dz=5mm  
Reference Value = 83.41 V/m; Power Drift = -0.11 dB  
Peak SAR (extrapolated) = 18.9 W/kg  
**SAR(1 g) = 12.7 W/kg; SAR(10 g) = 5.78 W/kg**  
Maximum value of SAR (measured) = 19.4 W/kg

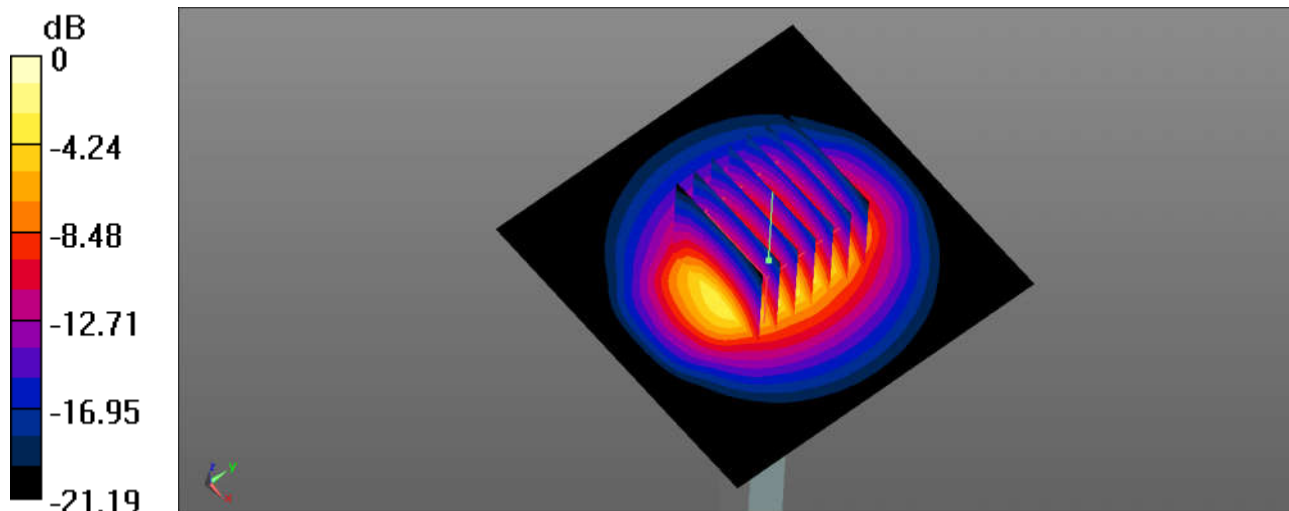

0 dB = 19.4 W/kg = 12.88 dBW/kg

### System Check\_Body\_2450MHz

#### DUT: D2450V2 - SN:840

Communication System: UID 0, CW; Frequency: 2450 MHz; Duty Cycle: 1:1

Medium: MSL\_2450 Medium parameters used:  $f = 2450$  MHz;  $\sigma = 1.917$  S/m;  $\epsilon_r = 53.459$ ;  $\rho = 1000$  kg/m<sup>3</sup>

Ambient Temperature : 23.6 °C ; Liquid Temperature : 22.6 °C

#### DASY5 Configuration:

- Probe: EX3DV4 - SN3857; ConvF(7.23, 7.23, 7.23); Calibrated: 2016.5.25;
- Sensor-Surface: 2mm (Mechanical Surface Detection)
- Electronics: DAE4 Sn1210; Calibrated: 2016.5.18
- Phantom: SAM3; Type: SAM; Serial: TP-1079
- Measurement SW: DASY52, Version 52.8 (8); SEMCAD X Version 14.6.10 (7331)

**Pin=250mW/Area Scan (71x71x1):** Interpolated grid: dx=1.200 mm, dy=1.200 mm

Maximum value of SAR (interpolated) = 20.5 W/kg

**Pin=250mW/Zoom Scan (7x7x7)/Cube 0:** Measurement grid: dx=5mm, dy=5mm, dz=5mm

Reference Value = 87.87 V/m; Power Drift = -0.02 dB

Peak SAR (extrapolated) = 27.1 W/kg

**SAR(1 g) = 13.2 W/kg; SAR(10 g) = 6.16 W/kg**

Maximum value of SAR (measured) = 20.2 W/kg

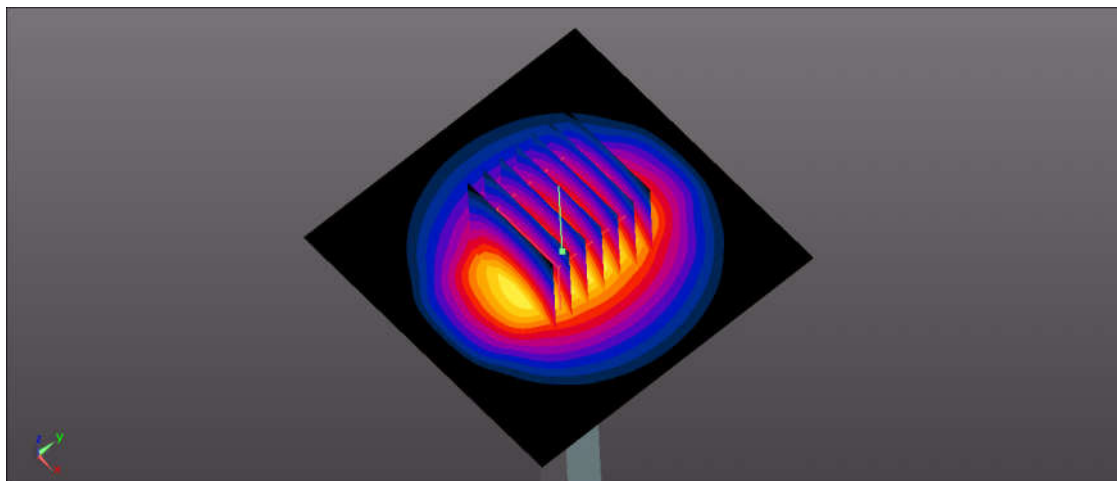
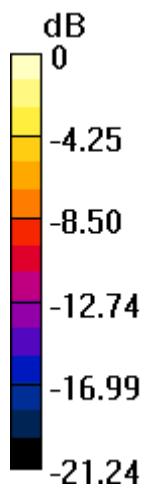

0 dB = 20.2 W/kg = 13.05 dBW/kg

### System Check\_Body\_2600MHz

**DUT: D2600V2 - SN:1061**

Communication System: UID 0, CW (0); Frequency: 2600 MHz; Duty Cycle: 1:1  
Medium: MSL\_2600 Medium parameters used:  $f = 2600$  MHz;  $\sigma = 2.196$  S/m;  $\epsilon_r = 52.103$ ;  $\rho = 1000$  kg/m<sup>3</sup>  
Ambient Temperature : 23.5 °C ; Liquid Temperature : 22.5 °C

#### DASY5 Configuration:

- Probe: EX3DV4 - SN3857; ConvF(7.13, 7.13, 7.13); Calibrated: 2016.5.25;
- Sensor-Surface: 2mm (Mechanical Surface Detection)
- Electronics: DAE4 Sn1210; Calibrated: 2016.5.18
- Phantom: SAM3; Type: SAM; Serial: TP-1079
- Measurement SW: DASY52, Version 52.8 (8); SEMCAD X Version 14.6.10 (7331)

**Pin=250mW/Area Scan (71x71x1):** Interpolated grid: dx=1.200 mm, dy=1.200 mm  
Maximum value of SAR (interpolated) = 21.4 W/kg

**Pin=250mW/Zoom Scan (7x7x7)/Cube 0:** Measurement grid: dx=5mm, dy=5mm, dz=5mm  
Reference Value = 84.46 V/m; Power Drift = -0.08 dB  
Peak SAR (extrapolated) = 27.9 W/kg  
**SAR(1 g) = 13.8 W/kg; SAR(10 g) = 6.51 W/kg**  
Maximum value of SAR (measured) = 21.5 W/kg

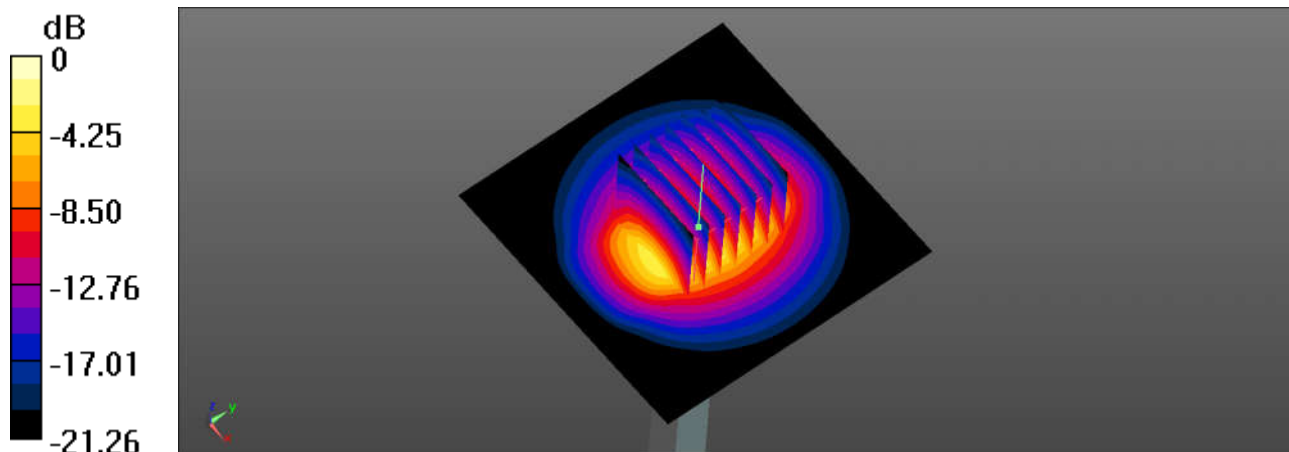

0 dB = 21.5 W/kg = 13.32 dBW/kg

### System Check\_Body\_5250MHz

#### DUT: D5GHzV2-SN:1113

Communication System: UID 0, CW (0); Frequency: 5250 MHz; Duty Cycle: 1:1  
Medium: MSL\_5000 Medium parameters used:  $f = 5250$  MHz;  $\sigma = 5.366$  S/m;  $\epsilon_r = 48.688$ ;  $\rho = 1000$  kg/m<sup>3</sup>  
Ambient Temperature : 23.7 °C ; Liquid Temperature : 22.7 °C

#### DASY5 Configuration:

- Probe: EX3DV4 - SN3857; ConvF(4.27, 4.27, 4.27); Calibrated: 2016.5.25;
- Sensor-Surface: 1.4mm (Mechanical Surface Detection)
- Electronics: DAE4 Sn1210; Calibrated: 2016.5.18
- Phantom: SAM3; Type: SAM; Serial: TP-1079
- Measurement SW: DASY52, Version 52.8 (8); SEMCAD X Version 14.6.10 (7331)

**Pin=100mW/Area Scan (71x71x1):** Interpolated grid: dx=1.000 mm, dy=1.000 mm  
Maximum value of SAR (interpolated) = 18.1 W/kg

**Pin=100mW/Zoom Scan (8x8x7)/Cube 0:** Measurement grid: dx=4mm, dy=4mm, dz=1.4mm  
Reference Value = 40.96 V/m; Power Drift = -0.13 dB  
Peak SAR (extrapolated) = 29.6 W/kg  
**SAR(1 g) = 7.69 W/kg; SAR(10 g) = 2.19 W/kg**  
Maximum value of SAR (measured) = 17.6 W/kg

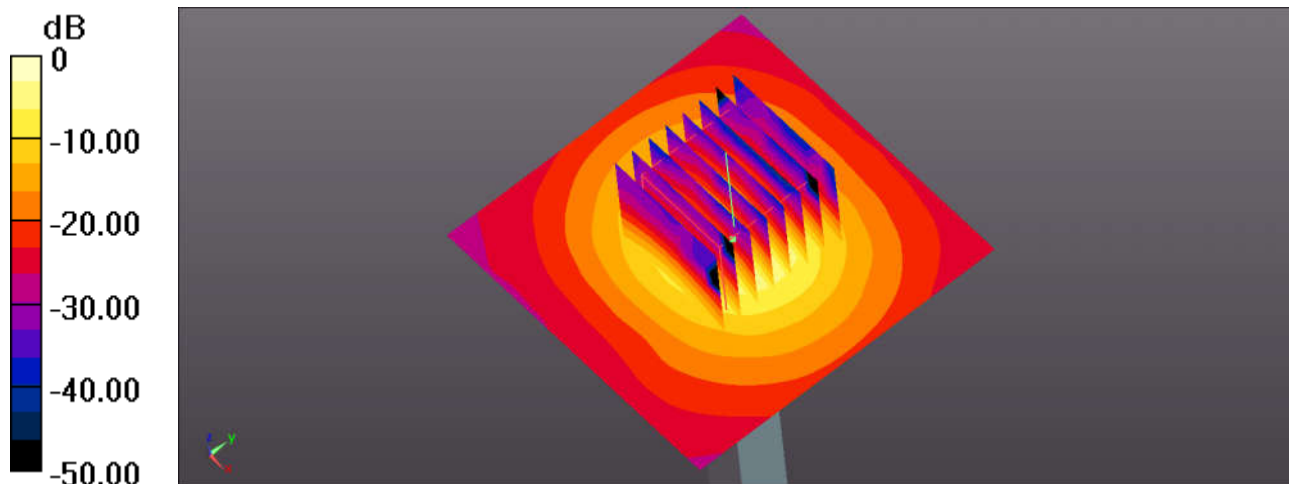

0 dB = 17.6 W/kg = 12.46 dBW/kg

### System Check\_Body\_5750MHz

#### DUT: D5GHzV2-SN:1113

Communication System: UID 0, CW (0); Frequency: 5750 MHz; Duty Cycle: 1:1  
Medium: MSL\_5000 Medium parameters used:  $f = 5750$  MHz;  $\sigma = 6.234$  S/m;  $\epsilon_r = 48.199$ ;  $\rho = 1000$  kg/m<sup>3</sup>  
Ambient Temperature : 23.7 °C ; Liquid Temperature : 22.7 °C

#### DASY5 Configuration:

- Probe: EX3DV4 - SN3857; ConvF(3.97, 3.97, 3.97); Calibrated: 2016.5.25;
- Sensor-Surface: 1.4mm (Mechanical Surface Detection)
- Electronics: DAE4 Sn1210; Calibrated: 2016.5.18
- Phantom: SAM3; Type: SAM; Serial: TP-1079
- Measurement SW: DASY52, Version 52.8 (8); SEMCAD X Version 14.6.10 (7331)

**\Pin=100mW/Area Scan (71x71x1):** Interpolated grid: dx=1.000 mm, dy=1.000 mm  
Maximum value of SAR (interpolated) = 18.9 W/kg

**\Pin=100mW/Zoom Scan (8x8x7)/Cube 0:** Measurement grid: dx=4mm, dy=4mm, dz=1.4mm  
Reference Value = 38.30 V/m; Power Drift = -0.01 dB  
Peak SAR (extrapolated) = 33.1 W/kg  
**SAR(1 g) = 7.76 W/kg; SAR(10 g) = 2.21 W/kg**  
Maximum value of SAR (measured) = 19.0 W/kg

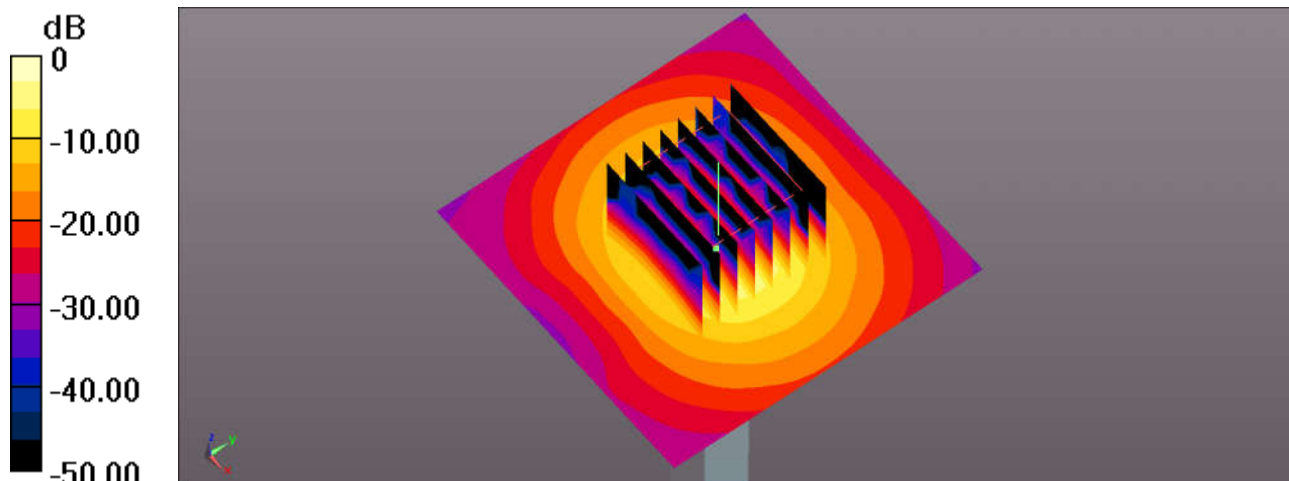

0 dB = 19.0 W/kg = 12.79 dBW/kg



**Appendix B. Plots of High SAR Measurement**

The plots are shown as follows.

### 01\_WCDMA Band V\_RMC 12.2Kbps\_Bottom Face\_0mm\_Ch4233\_Sensor On

Communication System: UID 0, UMTS (0); Frequency: 846.6 MHz; Duty Cycle: 1:1  
Medium: MSL\_850 Medium parameters used:  $f = 846.6$  MHz;  $\sigma = 0.99$  S/m;  $\epsilon_r = 54.037$ ;  $\rho = 1000$  kg/m<sup>3</sup>  
Ambient Temperature : 23.5 °C; Liquid Temperature : 22.8 °C

#### DASY5 Configuration:

- Probe: EX3DV4 - SN3857; ConvF(9.25, 9.25, 9.25); Calibrated: 2016.5.25;
- Sensor-Surface: 2mm (Mechanical Surface Detection)
- Electronics: DAE4 Sn1210; Calibrated: 2016.5.18
- Phantom: SAM3; Type: SAM; Serial: TP-1079
- Measurement SW: DASY52, Version 52.8 (8); SEMCAD X Version 14.6.10 (7331)

**Ch4233/Area Scan (81x71x1):** Interpolated grid: dx=1.500 mm, dy=1.500 mm  
Maximum value of SAR (interpolated) = 1.56 W/kg

**Ch4233/Zoom Scan (5x5x7)/Cube 0:** Measurement grid: dx=8mm, dy=8mm, dz=5mm  
Reference Value = 0.3460 V/m; Power Drift = 0.14 dB  
Peak SAR (extrapolated) = 2.71 W/kg  
**SAR(1 g) = 1.07 W/kg; SAR(10 g) = 0.490 W/kg**  
Maximum value of SAR (measured) = 1.92 W/kg

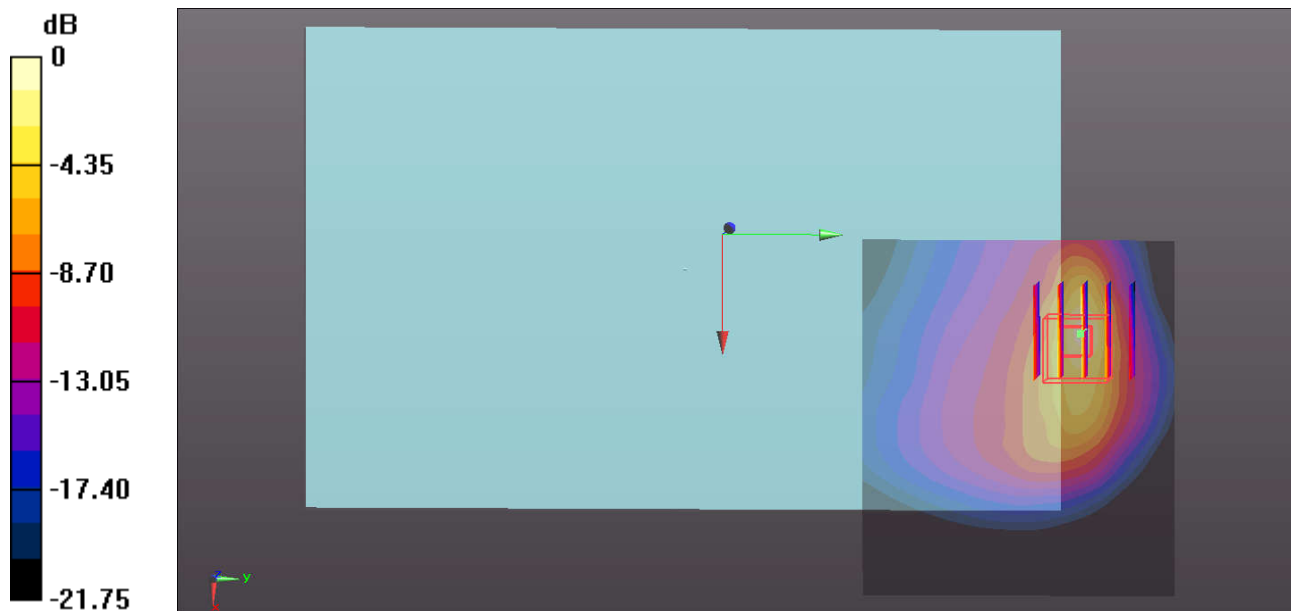

0 dB = 1.92 W/kg = 2.83 dBW/kg

### 02\_WCDMA Band IV\_RMC 12.2Kbps\_Curved of Edge 2\_0mm\_Ch1513\_Sensor On

Communication System: UID 0, UMTS (0); Frequency: 1752.6 MHz; Duty Cycle: 1:1  
Medium: MSL\_1750 Medium parameters used:  $f = 1752.6$  MHz;  $\sigma = 1.442$  S/m;  $\epsilon_r = 53.014$ ;  $\rho = 1000$  kg/m<sup>3</sup>  
Ambient Temperature : 23.4 °C ; Liquid Temperature : 22.7 °C

#### DASY5 Configuration:

- Probe: EX3DV4 - SN3857; ConvF(7.81, 7.81, 7.81); Calibrated: 2016.5.25;
- Sensor-Surface: 2mm (Mechanical Surface Detection)
- Electronics: DAE4 Sn1210; Calibrated: 2016.5.18
- Phantom: SAM3; Type: SAM; Serial: TP-1079
- Measurement SW: DASY52, Version 52.8 (8); SEMCAD X Version 14.6.10 (7331)

**Ch1513/Area Scan (71x51x1):** Interpolated grid: dx=1.500 mm, dy=1.500 mm  
Maximum value of SAR (interpolated) = 1.47 W/kg

**Ch1513/Zoom Scan (5x5x7)/Cube 0:** Measurement grid: dx=8mm, dy=8mm, dz=5mm  
Reference Value = 0.5020 V/m; Power Drift = -0.09 dB  
Peak SAR (extrapolated) = 2.28 W/kg  
**SAR(1 g) = 1.01 W/kg; SAR(10 g) = 0.439 W/kg**  
Maximum value of SAR (measured) = 1.60 W/kg

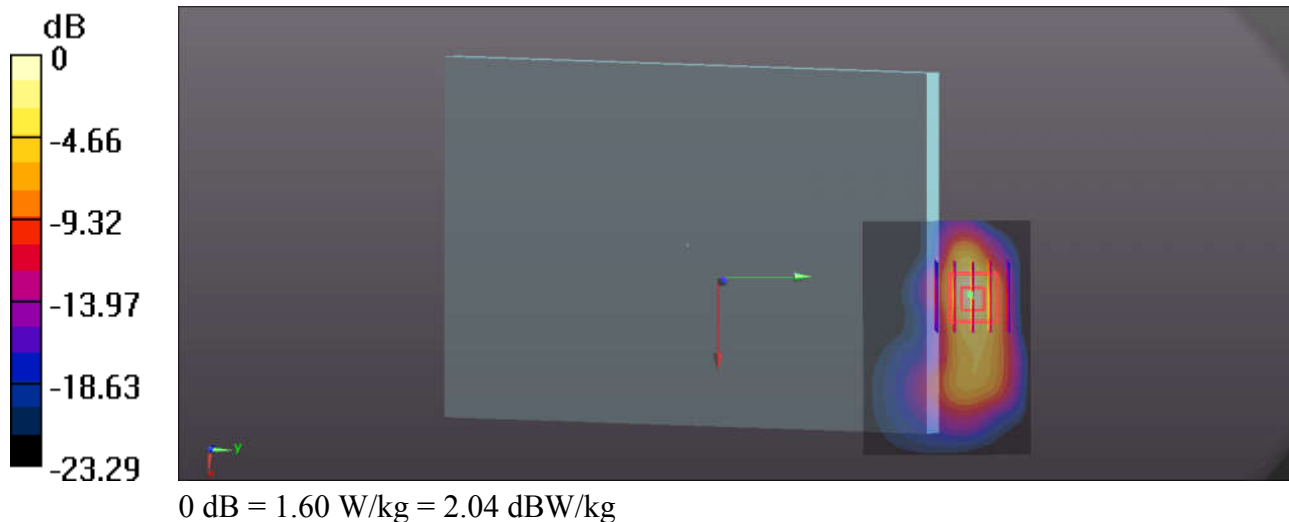

### 03\_WCDMA Band II\_RMC 12.2Kbps\_Bottom Face\_13mm\_Ch9538\_Sensor Off

Communication System: UID 0, UMTS (0); Frequency: 1907.6 MHz; Duty Cycle: 1:1  
Medium: MSL\_1900 Medium parameters used:  $f = 1907.6$  MHz;  $\sigma = 1.541$  S/m;  $\epsilon_r = 54.036$ ;  $\rho = 1000$  kg/m<sup>3</sup>  
Ambient Temperature : 23.4 °C ; Liquid Temperature : 22.7 °C

#### DASY5 Configuration:

- Probe: EX3DV4 - SN3857; ConvF(7.55, 7.55, 7.55); Calibrated: 2016.5.25;
- Sensor-Surface: 2mm (Mechanical Surface Detection)
- Electronics: DAE4 Sn1210; Calibrated: 2016.5.18
- Phantom: SAM3; Type: SAM; Serial: TP-1079
- Measurement SW: DASY52, Version 52.8 (8); SEMCAD X Version 14.6.10 (7331)

**Ch9538/Area Scan (81x61x1):** Interpolated grid: dx=1.500 mm, dy=1.500 mm  
Maximum value of SAR (interpolated) = 1.66 W/kg

**Ch9538/Zoom Scan (5x5x7)/Cube 0:** Measurement grid: dx=8mm, dy=8mm, dz=5mm  
Reference Value = 0.4740 V/m; Power Drift = 0.06 dB  
Peak SAR (extrapolated) = 1.83 W/kg  
**SAR(1 g) = 1.1 W/kg; SAR(10 g) = 0.605 W/kg**  
Maximum value of SAR (measured) = 1.49 W/kg

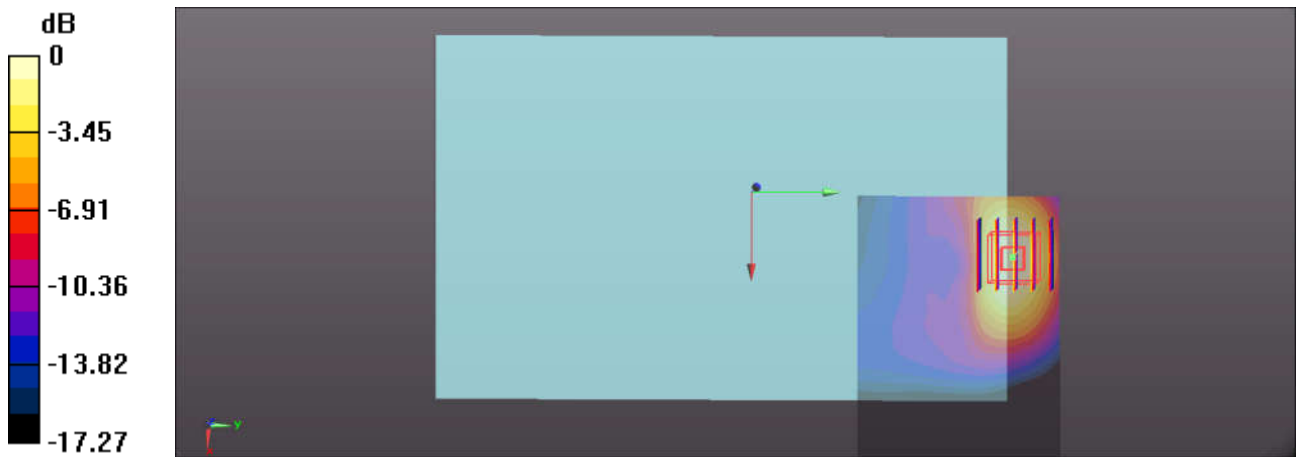

0 dB = 1.49 W/kg = 1.73 dBW/kg

### 04\_LTE Band12\_20M\_QPSK\_25RB\_0Offset\_Bottom Face\_0mm\_Ch23095\_Sensor On

Communication System: UID 0, FDD\_LTE (0); Frequency: 707.5 MHz; Duty Cycle: 1:1  
Medium: MSL\_750 Medium parameters used :  $f = 707.5$  MHz;  $\sigma = 0.918$  S/m;  $\epsilon_r = 55.983$ ;  $\rho = 1000$  kg/m<sup>3</sup>  
Ambient Temperature : 23.5 °C ; Liquid Temperature : 22.8 °C

#### DASY5 Configuration:

- Probe: EX3DV4 - SN3857; ConvF(9.45, 9.45, 9.45); Calibrated: 2016.5.25;
- Sensor-Surface: 2mm (Mechanical Surface Detection)
- Electronics: DAE4 Sn1210; Calibrated: 2016.5.18
- Phantom: SAM3; Type: SAM; Serial: TP-1079
- Measurement SW: DASY52, Version 52.8 (8); SEMCAD X Version 14.6.10 (7331)

**Ch23095/Area Scan (81x61x1):** Interpolated grid: dx=1.500 mm, dy=1.500 mm.  
Maximum value of SAR (interpolated) = 1.46 W/kg

**Ch23095/Zoom Scan (5x5x7)/Cube 0:** Measurement grid: dx=8mm, dy=8mm, dz=5mm  
Reference Value = 1.579 V/m; Power Drift = 0.08 dB  
Peak SAR (extrapolated) = 2.93 W/kg  
**SAR(1 g) = 1.12 W/kg; SAR(10 g) = 0.512 W/kg**  
Maximum value of SAR (measured) = 2.06 W/kg

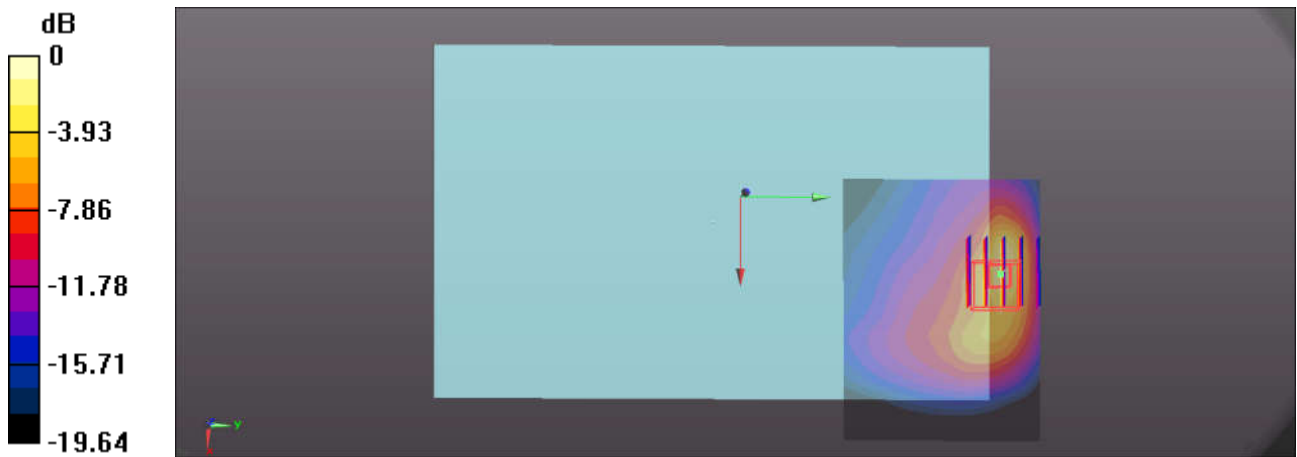

0 dB = 2.06 W/kg = 3.14 dBW/kg

**05\_LTE Band5\_10M\_QPSK\_1RB\_0Offset\_Edge 2\_0mm\_Ch20525\_Sensor On**

Communication System: UID 0, FDD\_LTE (0); Frequency: 836.5 MHz; Duty Cycle: 1:1  
Medium: MSL\_850 Medium parameters used:  $f = 836.5$  MHz;  $\sigma = 0.98$  S/m;  $\epsilon_r = 54.153$ ;  $\rho = 1000$  kg/m<sup>3</sup>  
Ambient Temperature : 23.5 °C ; Liquid Temperature : 22.8 °C

DASY5 Configuration:

- Probe: EX3DV4 - SN3857; ConvF(9.25, 9.25, 9.25); Calibrated: 2016.5.25;
- Sensor-Surface: 2mm (Mechanical Surface Detection)
- Electronics: DAE4 Sn1210; Calibrated: 2016.5.18
- Phantom: SAM3; Type: SAM; Serial: TP-1079
- Measurement SW: DASY52, Version 52.8 (8); SEMCAD X Version 14.6.10 (7331)

**Ch1413/Area Scan (41x81x1):** Interpolated grid: dx=1.500 mm, dy=1.500 mm  
Maximum value of SAR (interpolated) = 1.36 W/kg

**Ch1413/Zoom Scan (5x5x7)/Cube 0:** Measurement grid: dx=8mm, dy=8mm, dz=5mm  
Reference Value = 19.21 V/m; Power Drift = 0.03 dB  
Peak SAR (extrapolated) = 2.31 W/kg  
**SAR(1 g) = 1.06 W/kg; SAR(10 g) = 0.572 W/kg**  
Maximum value of SAR (measured) = 1.68 W/kg

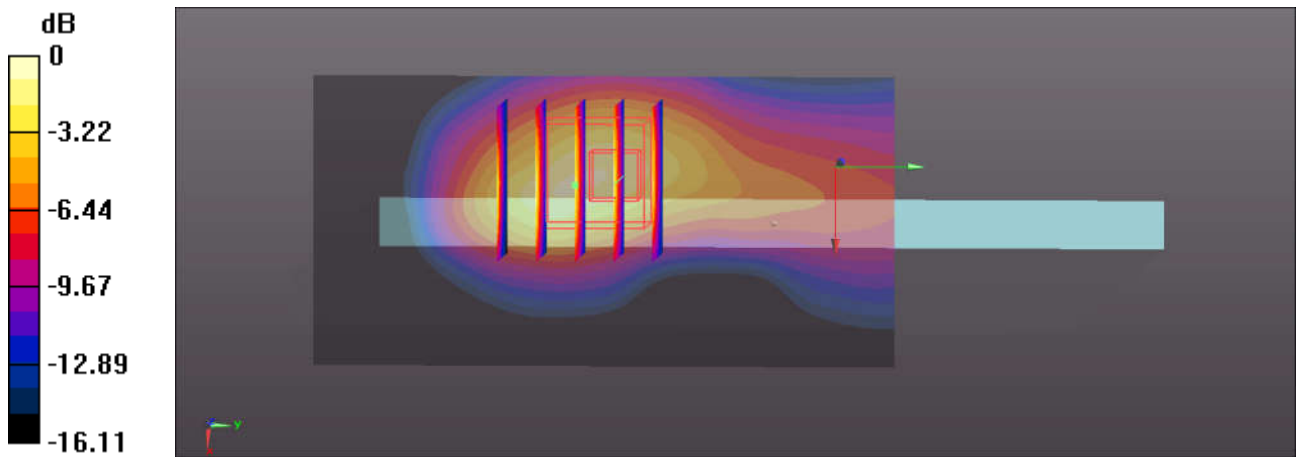

0 dB = 1.68 W/kg = 2.25 dBW/kg

### 06\_LTE Band4\_20M\_QPSK\_100RB\_0Offset\_Edge 2\_0mm\_Ch20175\_Sensor On

Communication System: UID 0, FDD\_LTE (0); Frequency: 1732.5 MHz; Duty Cycle: 1:1  
Medium: MSL\_1750 Medium parameters used:  $f = 1732.5$  MHz;  $\sigma = 1.418$  S/m;  $\epsilon_r = 53.086$ ;  $\rho = 1000$  kg/m<sup>3</sup>  
Ambient Temperature : 23.4 °C ; Liquid Temperature : 22.7 °C

#### DASY5 Configuration:

- Probe: EX3DV4 - SN3857; ConvF(7.81, 7.81, 7.81); Calibrated: 2016.5.25;
- Sensor-Surface: 2mm (Mechanical Surface Detection)
- Electronics: DAE4 Sn1210; Calibrated: 2016.5.18
- Phantom: SAM3; Type: SAM; Serial: TP-1079
- Measurement SW: DASY52, Version 52.8 (8); SEMCAD X Version 14.6.10 (7331)

**Ch20175/Area Scan (41x81x1):** Interpolated grid: dx=1.500 mm, dy=1.500 mm  
Maximum value of SAR (interpolated) = 1.65 W/kg

**Ch20175/Zoom Scan (5x5x7)/Cube 0:** Measurement grid: dx=8mm, dy=8mm, dz=5mm  
Reference Value = 16.11 V/m; Power Drift = 0.14 dB  
Peak SAR (extrapolated) = 2.44 W/kg  
**SAR(1 g) = 1.06 W/kg; SAR(10 g) = 0.459 W/kg**  
Maximum value of SAR (measured) = 1.76 W/kg

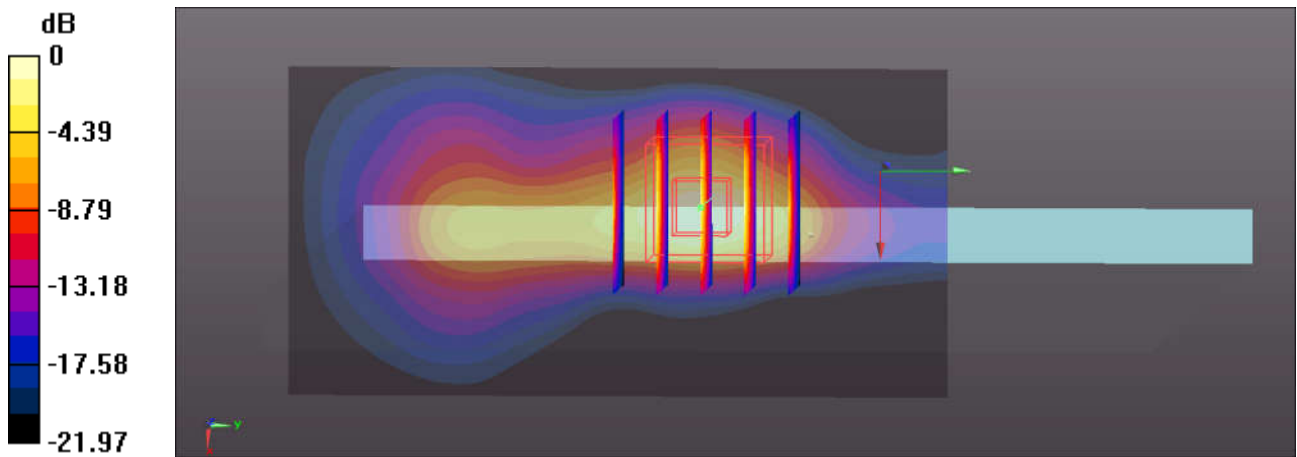

0 dB = 1.76 W/kg = 2.46 dBW/kg

### 07\_LTE Band2\_20M\_QPSK\_1RB\_49Offset\_Curved of Edge 2\_0mm\_Ch19100\_Sensor On

Communication System: UID 0, FDD\_LTE (0); Frequency: 1900 MHz; Duty Cycle: 1:1  
Medium: MSL\_1900 Medium parameters used:  $f = 1900$  MHz;  $\sigma = 1.532$  S/m;  $\epsilon_r = 54.06$ ;  $\rho = 1000$  kg/m<sup>3</sup>  
Ambient Temperature : 23.4 °C ; Liquid Temperature : 22.7 °C

#### DASY5 Configuration:

- Probe: EX3DV4 - SN3857; ConvF(7.55, 7.55, 7.55); Calibrated: 2016.5.25;
- Sensor-Surface: 2mm (Mechanical Surface Detection)
- Electronics: DAE4 Sn1210; Calibrated: 2016.5.18
- Phantom: SAM3; Type: SAM; Serial: TP-1079
- Measurement SW: DASY52, Version 52.8 (8); SEMCAD X Version 14.6.10 (7331)

**Ch19100/Area Scan (71x51x1):** Interpolated grid: dx=1.500 mm, dy=1.500 mm  
Maximum value of SAR (interpolated) = 1.65 W/kg

**Ch19100/Zoom Scan (5x5x7)/Cube 0:** Measurement grid: dx=8mm, dy=8mm, dz=5mm  
Reference Value = 0.9320 V/m; Power Drift = -0.16 dB  
Peak SAR (extrapolated) = 2.41 W/kg  
**SAR(1 g) = 1.08 W/kg; SAR(10 g) = 0.453 W/kg**  
Maximum value of SAR (measured) = 1.80 W/kg

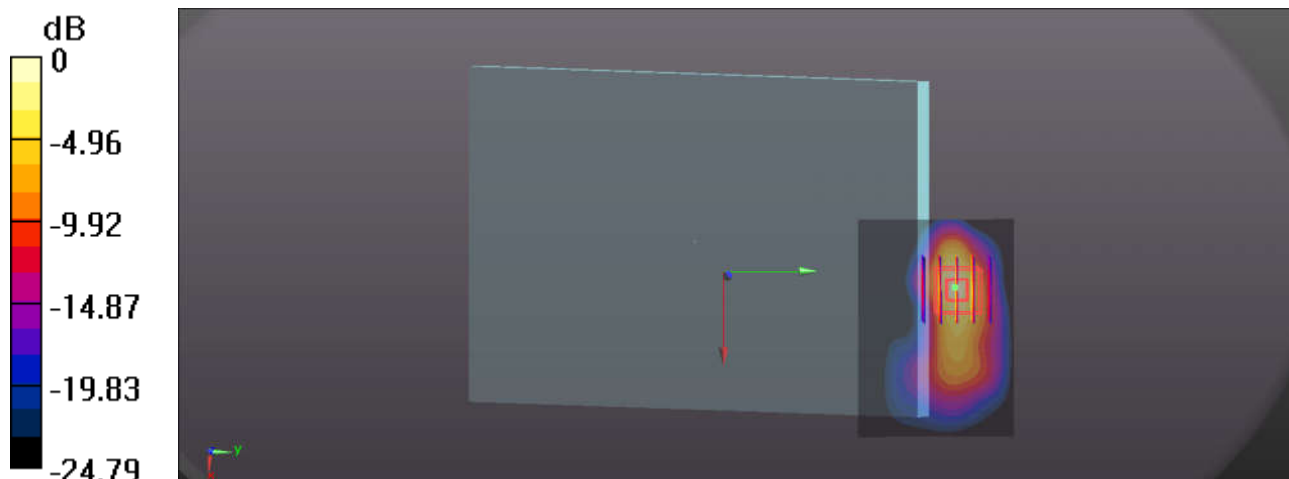

0 dB = 1.80 W/kg = 2.55 dBW/kg

### 08\_LTE Band30\_10M\_QPSK\_1RB\_25Offset\_Bottom Face\_0mm\_Ch27710\_Sensor On

Communication System: UID 0, FDD\_LTE (0); Frequency: 2310 MHz; Duty Cycle: 1:1  
Medium: MSL\_2300 Medium parameters used:  $f = 2310$  MHz;  $\sigma = 1.796$  S/m;  $\epsilon_r = 53.128$ ;  $\rho = 1000$  kg/m<sup>3</sup>  
Ambient Temperature : 23.5 °C ; Liquid Temperature : 22.5 °C

#### DASY5 Configuration:

- Probe: EX3DV4 - SN3857; ConvF(7.31, 7.31, 7.31); Calibrated: 2016.5.25;
- Sensor-Surface: 2mm (Mechanical Surface Detection)
- Electronics: DAE4 Sn1210; Calibrated: 2016.5.18
- Phantom: SAM3; Type: SAM; Serial: TP-1079
- Measurement SW: DASY52, Version 52.8 (8); SEMCAD X Version 14.6.10 (7331)

**Ch27710/Area Scan (91x61x1):** Interpolated grid: dx=1.200 mm, dy=1.200 mm  
Maximum value of SAR (interpolated) = 2.00 W/kg

**Ch27710/Zoom Scan (7x7x7)/Cube 0:** Measurement grid: dx=5mm, dy=5mm, dz=5mm  
Reference Value = 0.5120 V/m; Power Drift = -0.09 dB  
Peak SAR (extrapolated) = 2.84 W/kg  
**SAR(1 g) = 1.14 W/kg; SAR(10 g) = 0.401 W/kg**  
Maximum value of SAR (measured) = 2.01 W/kg

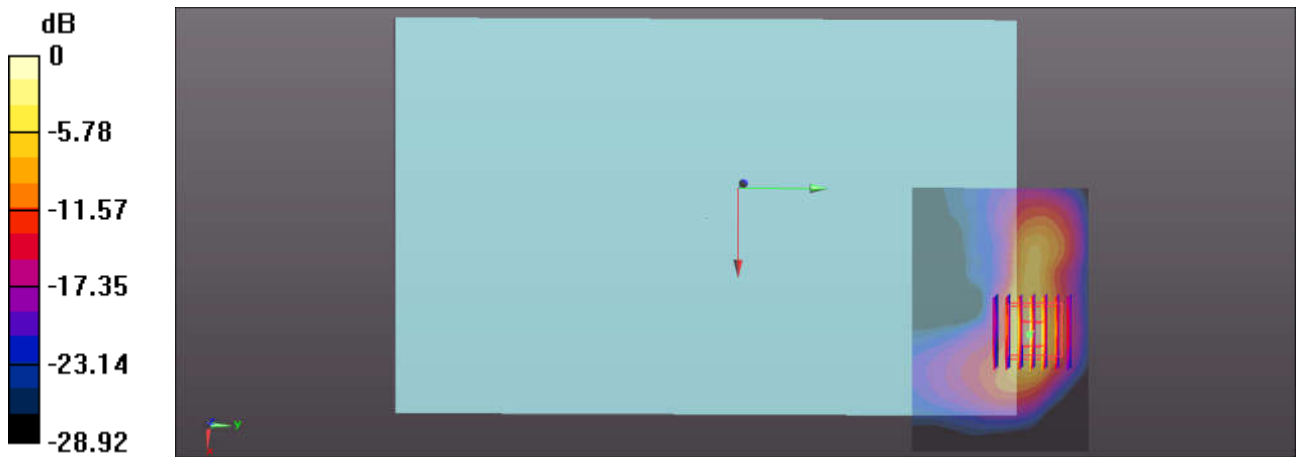

0 dB = 2.01 W/kg = 3.03 dBW/kg

**09\_LTE Band7\_20M\_QPSK\_1RB\_49Offset\_Bottom Face\_0mm\_Ch20850\_Sensor Off**

Communication System: UID 0, FDD\_LTE (0); Frequency: 2510 MHz; Duty Cycle: 1:1  
Medium: MSL\_2600 Medium parameters used:  $f = 2510$  MHz;  $\sigma = 2.066$  S/m;  $\epsilon_r = 52.426$ ;  $\rho = 1000$  kg/m<sup>3</sup>  
Ambient Temperature : 23.5 °C ; Liquid Temperature : 22.5 °C

DASY5 Configuration:

- Probe: EX3DV4 - SN3857; ConvF(7.13, 7.13, 7.13); Calibrated: 2016.5.25;
- Sensor-Surface: 2mm (Mechanical Surface Detection)
- Electronics: DAE4 Sn1210; Calibrated: 2016.5.18
- Phantom: SAM3; Type: SAM; Serial: TP-1079
- Measurement SW: DASY52, Version 52.8 (8); SEMCAD X Version 14.6.10 (7331)

**Ch20850/Area Scan (101x81x1):** Interpolated grid: dx=1.200 mm, dy=1.200 mm  
Maximum value of SAR (interpolated) = 1.35 W/kg

**Ch20850/Zoom Scan (7x7x7)/Cube 0:** Measurement grid: dx=5mm, dy=5mm, dz=5mm  
Reference Value = 2.473 V/m; Power Drift = -0.07 dB  
Peak SAR (extrapolated) = 1.92 W/kg  
**SAR(1 g) = 0.993 W/kg; SAR(10 g) = 0.470 W/kg**  
Maximum value of SAR (measured) = 1.45 W/kg

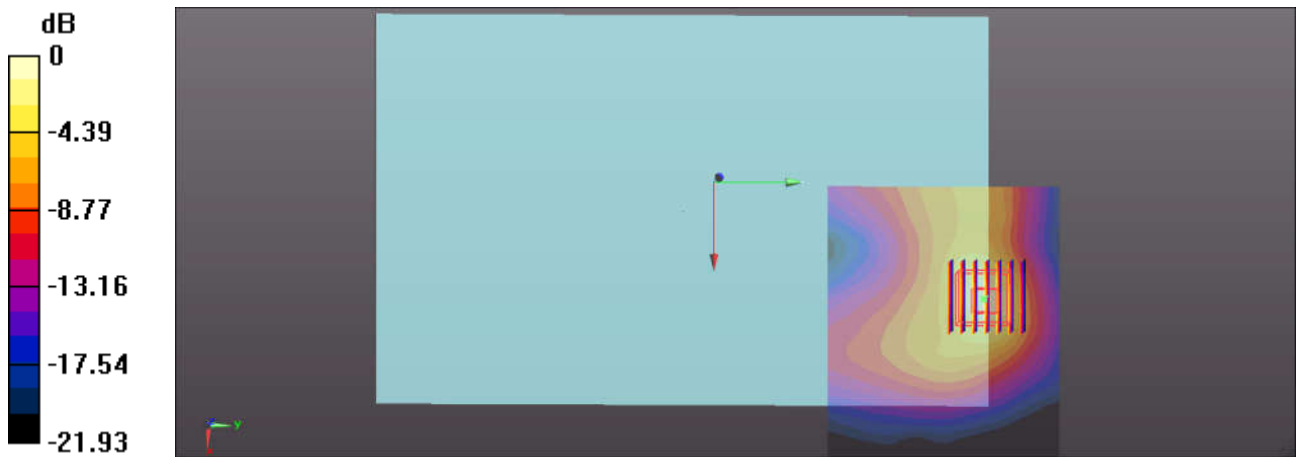

0 dB = 1.45 W/kg = 1.61 dBW/kg

### 10\_WLAN2.4GHz\_802.11b 1Mbps\_Bottom Face\_0mm\_Ch11

Communication System: UID 0, WIFI (0); Frequency: 2462 MHz; Duty Cycle: 1:1.025  
Medium: MSL\_2450 Medium parameters used:  $f = 2462$  MHz;  $\sigma = 1.933$  S/m;  $\epsilon_r = 53.421$ ;  $\rho = 1000$  kg/m<sup>3</sup>  
Ambient Temperature : 23.6 °C ; Liquid Temperature : 22.6 °C

#### DASY5 Configuration:

- Probe: EX3DV4 - SN3857; ConvF(7.23, 7.23, 7.23); Calibrated: 2016.5.25;
- Sensor-Surface: 2mm (Mechanical Surface Detection)
- Electronics: DAE4 Sn1210; Calibrated: 2016.5.18
- Phantom: SAM3; Type: SAM; Serial: TP-1079
- Measurement SW: DASY52, Version 52.8 (8); SEMCAD X Version 14.6.10 (7331)

**Ch11/Area Scan (61x91x1):** Interpolated grid: dx=1.200 mm, dy=1.200 mm  
Maximum value of SAR (interpolated) = 0.865 W/kg

**Ch11/Zoom Scan (7x7x7)/Cube 0:** Measurement grid: dx=5mm, dy=5mm, dz=5mm  
Reference Value = 0 V/m; Power Drift = 0.02 dB  
Peak SAR (extrapolated) = 1.36 W/kg  
**SAR(1 g) = 0.466 W/kg; SAR(10 g) = 0.215 W/kg**  
Maximum value of SAR (measured) = 0.859 W/kg

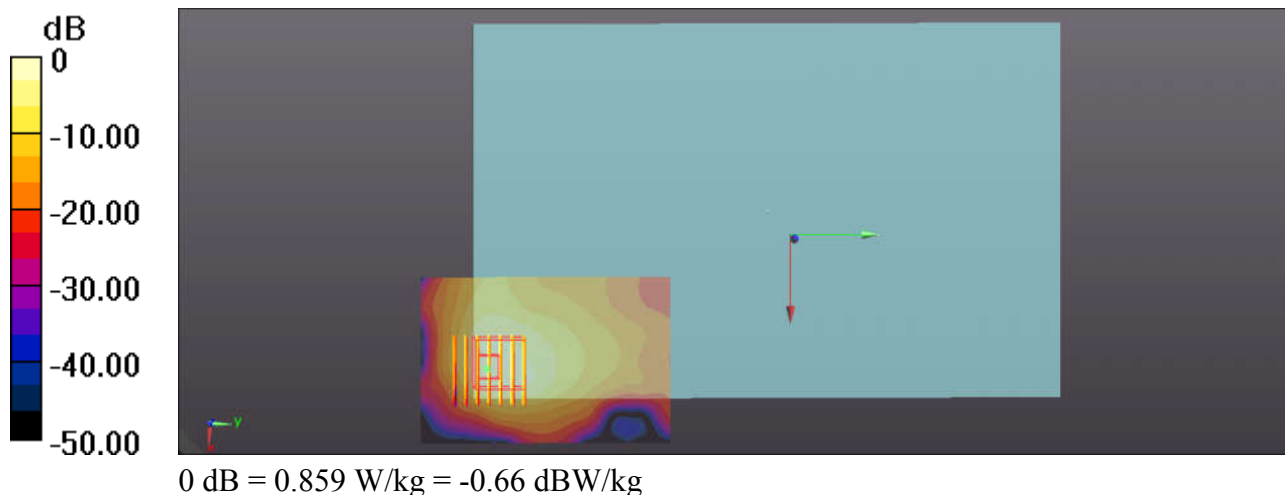

### 11\_WLAN5.2GHz\_802.11a 6Mbps\_Bottom Face\_0mm\_Ch36

Communication System: UID 0, WIFI (0); Frequency: 5180 MHz; Duty Cycle: 1:1.144  
Medium: MSL\_5000 Medium parameters used:  $f = 5180 \text{ MHz}$ ;  $\sigma = 5.454 \text{ S/m}$ ;  $\epsilon_r = 49.155$ ;  $\rho = 1000 \text{ kg/m}^3$   
Ambient Temperature :  $23.7 \text{ }^\circ\text{C}$  ; Liquid Temperature :  $22.7 \text{ }^\circ\text{C}$

#### DASY5 Configuration:

- Probe: EX3DV4 - SN3857; ConvF(4.27, 4.27, 4.27); Calibrated: 2016.5.25;
- Sensor-Surface: 1.4mm (Mechanical Surface Detection)
- Electronics: DAE4 Sn1210; Calibrated: 2016.5.18
- Phantom: SAM3; Type: SAM; Serial: TP-1079
- Measurement SW: DASY52, Version 52.8 (8); SEMCAD X Version 14.6.10 (7331)

**Ch36/Area Scan (81x111x1):** Interpolated grid:  $dx=1.000 \text{ mm}$ ,  $dy=1.000 \text{ mm}$   
Maximum value of SAR (interpolated) =  $0.947 \text{ W/kg}$

**Ch36/Zoom Scan (8x8x7)/Cube 0:** Measurement grid:  $dx=4\text{mm}$ ,  $dy=4\text{mm}$ ,  $dz=1.4\text{mm}$   
Reference Value =  $0 \text{ V/m}$ ; Power Drift =  $0.02 \text{ dB}$   
Peak SAR (extrapolated) =  $2.28 \text{ W/kg}$   
**SAR(1 g) =  $0.473 \text{ W/kg}$ ; SAR(10 g) =  $0.117 \text{ W/kg}$**   
Maximum value of SAR (measured) =  $1.29 \text{ W/kg}$

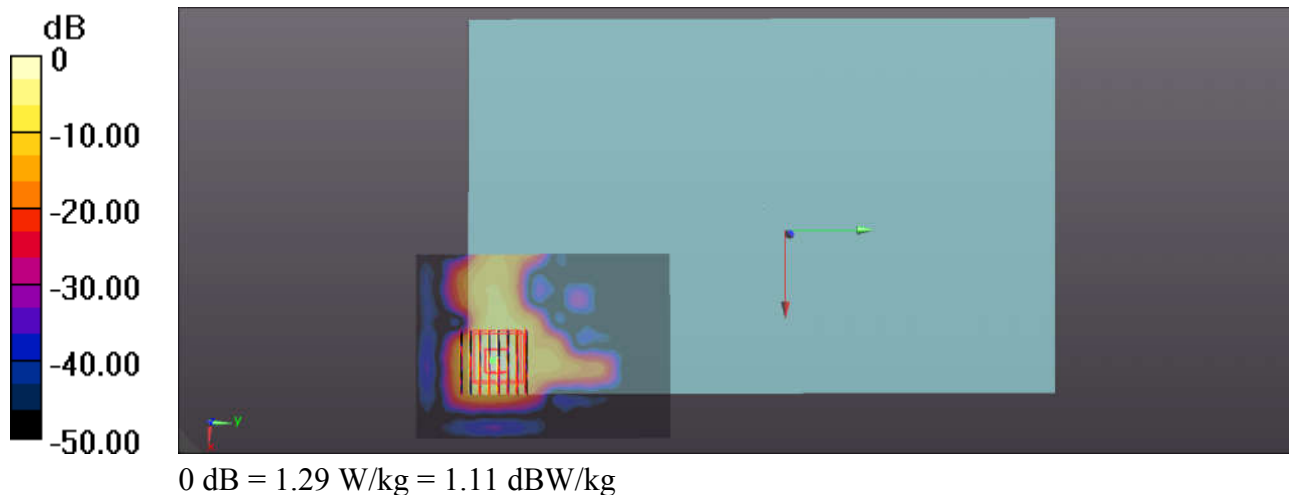

### 12\_WLAN5.8GHz\_802.11a 6Mbps\_Edge 4\_0mm\_Ch149

Communication System: UID 0, WIFI (0); Frequency: 5745 MHz; Duty Cycle: 1:1.144  
Medium: MSL\_5000 Medium parameters used:  $f = 5745$  MHz;  $\sigma = 6.226$  S/m;  $\epsilon_r = 48.215$ ;  $\rho = 1000$  kg/m<sup>3</sup>  
Ambient Temperature : 23.7 °C ; Liquid Temperature : 22.7 °C

#### DASY5 Configuration:

- Probe: EX3DV4 - SN3857; ConvF(3.97, 3.97, 3.97); Calibrated: 2016.5.25;
- Sensor-Surface: 1.4mm (Mechanical Surface Detection)
- Electronics: DAE4 Sn1210; Calibrated: 2016.5.18
- Phantom: SAM3; Type: SAM; Serial: TP-1079
- Measurement SW: DASY52, Version 52.8 (8); SEMCAD X Version 14.6.10 (7331)

**Ch149/Area Scan (41x111x1):** Interpolated grid: dx=1.000 mm, dy=1.000 mm  
Maximum value of SAR (interpolated) = 0.785 W/kg

**Ch149/Zoom Scan (8x8x7)/Cube 0:** Measurement grid: dx=4mm, dy=4mm, dz=1.4mm  
Reference Value = 1.334 V/m; Power Drift = 0.08 dB  
Peak SAR (extrapolated) = 1.76 W/kg  
**SAR(1 g) = 0.404 W/kg; SAR(10 g) = 0.112 W/kg**  
Maximum value of SAR (measured) = 1.08 W/kg

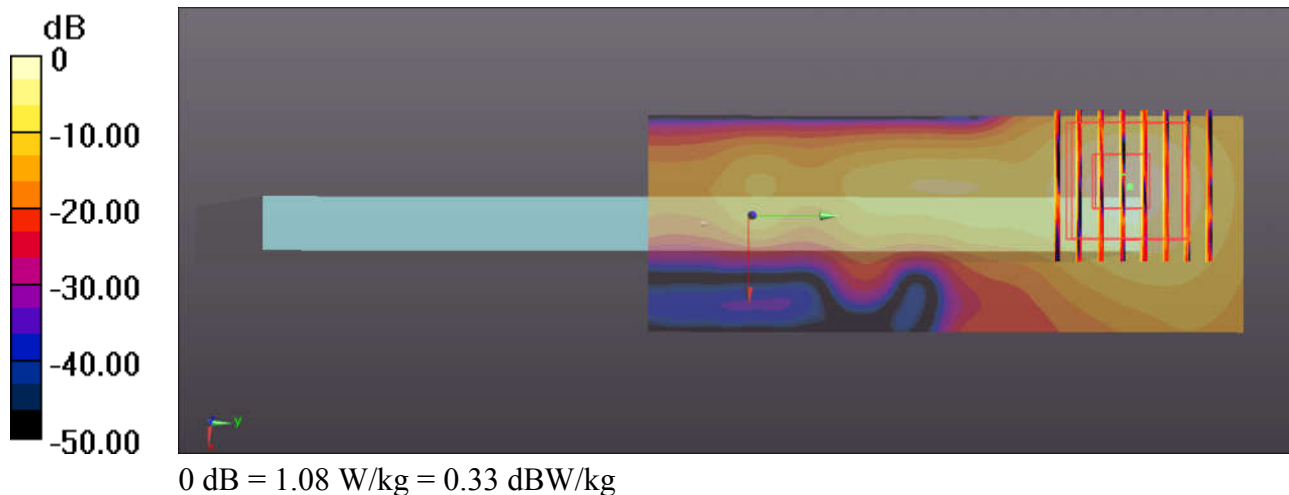



**Appendix C. DASYS Calibration Certificate**

The DASYS calibration certificates are shown as follows.



Client

**Sporton-CN**

Certificate No: **Z16-97221**

## CALIBRATION CERTIFICATE

Object: **D750V3 - SN: 1065**

Calibration Procedure(s): **FD-Z11-003-01**  
**Calibration Procedures for dipole validation kits**

Calibration date: **November 21, 2016**

This calibration Certificate documents the traceability to national standards, which realize the physical units of measurements(SI). The measurements and the uncertainties with confidence probability are given on the following pages and are part of the certificate.

All calibrations have been conducted in the closed laboratory facility: environment temperature(22±3)°C and humidity<70%.

Calibration Equipment used (M&TE critical for calibration)

Primary Standards	ID #	Cal Date(Calibrated by, Certificate No.)	Scheduled Calibration
Power Meter NRP2	101919	27-Jun-16 (CTTL, No.J16X04771)	Jun-17
Power sensor NRP-Z91	101547	27-Jun-16 (CTTL, No.J16X04771)	Jun-17
Reference Probe EX3DV4	SN 7433	26-Sep-16(SPEAG,No.EX3-7433_Sep16)	Sep-17
DAE4	SN 771	02-Feb-16(CTTL-SPEAG,No.Z16-97011)	Feb-17
Secondary Standards	ID #	Cal Date(Calibrated by, Certificate No.)	Scheduled Calibration
Signal Generator E4438C	MY49071430	01-Feb-16 (CTTL, No.J16X00893)	Jan-17
Network Analyzer E5071C	MY46110673	26-Jan-16 (CTTL, No.J16X00894)	Jan-17

	Name	Function	Signature
Calibrated by:	Zhao Jing	SAR Test Engineer	
Reviewed by:	Qi Dianyuan	SAR Project Leader	
Approved by:	Lu Bingsong	Deputy Director of the laboratory	

Issued: November 26, 2016

This calibration certificate shall not be reproduced except in full without written approval of the laboratory.



### Glossary:

TSL	tissue simulating liquid
ConvF	sensitivity in TSL / NORM <sub>x,y,z</sub>
N/A	not applicable or not measured

### Calibration is Performed According to the Following Standards:

- IEEE Std 1528-2013, "IEEE Recommended Practice for Determining the Peak Spatial-Averaged Specific Absorption Rate (SAR) in the Human Head from Wireless Communications Devices: Measurement Techniques", June 2013
- IEC 62209-1, "Procedure to measure the Specific Absorption Rate (SAR) For hand-held devices used in close proximity to the ear (frequency range of 300MHz to 3GHz)", February 2005
- IEC 62209-2, "Procedure to measure the Specific Absorption Rate (SAR) For wireless communication devices used in close proximity to the human body (frequency range of 30MHz to 6GHz)", March 2010
- KDB865664, SAR Measurement Requirements for 100 MHz to 6 GHz

### Additional Documentation:

- DASY4/5 System Handbook

### Methods Applied and Interpretation of Parameters:

- Measurement Conditions:** Further details are available from the Validation Report at the end of the certificate. All figures stated in the certificate are valid at the frequency indicated.
- Antenna Parameters with TSL:** The dipole is mounted with the spacer to position its feed point exactly below the center marking of the flat phantom section, with the arms oriented parallel to the body axis.
- Feed Point Impedance and Return Loss:** These parameters are measured with the dipole positioned under the liquid filled phantom. The impedance stated is transformed from the measurement at the SMA connector to the feed point. The Return Loss ensures low reflected power. No uncertainty required.
- Electrical Delay:** One-way delay between the SMA connector and the antenna feed point. No uncertainty required.
- SAR measured:** SAR measured at the stated antenna input power.
- SAR normalized:** SAR as measured, normalized to an input power of 1 W at the antenna connector.
- SAR for nominal TSL parameters:** The measured TSL parameters are used to calculate the nominal SAR result.

The reported uncertainty of measurement is stated as the standard uncertainty of Measurement multiplied by the coverage factor  $k=2$ , which for a normal distribution Corresponds to a coverage probability of approximately 95%.



Add: No.51 Xueyuan Road, Haidian District, Beijing, 100191, China  
 Tel: +86-10-62304633-2079 Fax: +86-10-62304633-2504  
 E-mail: cttl@chinattl.com Http://www.chinattl.cn

### Measurement Conditions

DASY system configuration, as far as not given on page 1.

DASY Version	DASY52	52.8.8.1258
Extrapolation	Advanced Extrapolation	
Phantom	Triple Flat Phantom 5.1C	
Distance Dipole Center - TSL	15 mm	with Spacer
Zoom Scan Resolution	dx, dy, dz = 5 mm	
Frequency	750 MHz ± 1 MHz	

### Head TSL parameters

The following parameters and calculations were applied.

	Temperature	Permittivity	Conductivity
Nominal Head TSL parameters	22.0 °C	41.9	0.89 mho/m
Measured Head TSL parameters	(22.0 ± 0.2) °C	41.8 ± 6 %	0.91 mho/m ± 6 %
Head TSL temperature change during test	<1.0 °C	---	---

### SAR result with Head TSL

SAR averaged over 1 cm <sup>3</sup> (1 g) of Head TSL	Condition	
SAR measured	250 mW input power	2.11 mW / g
SAR for nominal Head TSL parameters	normalized to 1W	8.32 mW / g ± 20.8 % (k=2)
SAR averaged over 10 cm <sup>3</sup> (10 g) of Head TSL	Condition	
SAR measured	250 mW input power	1.41 mW / g
SAR for nominal Head TSL parameters	normalized to 1W	5.58 mW / g ± 20.4 % (k=2)

### Body TSL parameters

The following parameters and calculations were applied.

	Temperature	Permittivity	Conductivity
Nominal Body TSL parameters	22.0 °C	55.5	0.96 mho/m
Measured Body TSL parameters	(22.0 ± 0.2) °C	54.5 ± 6 %	0.95 mho/m ± 6 %
Body TSL temperature change during test	<1.0 °C	---	---

### SAR result with Body TSL

SAR averaged over 1 cm <sup>3</sup> (1 g) of Body TSL	Condition	
SAR measured	250 mW input power	2.16 mW / g
SAR for nominal Body TSL parameters	normalized to 1W	8.71 mW / g ± 20.8 % (k=2)
SAR averaged over 10 cm <sup>3</sup> (10 g) of Body TSL	Condition	
SAR measured	250 mW input power	1.46 mW / g
SAR for nominal Body TSL parameters	normalized to 1W	5.88 mW / g ± 20.4 % (k=2)



Add: No.51 Xueyuan Road, Haidian District, Beijing, 100191, China  
Tel: +86-10-62304633-2079 Fax: +86-10-62304633-2504  
E-mail: cttl@chinattl.com Http://www.chinattl.cn

## Appendix

### Antenna Parameters with Head TSL

Impedance, transformed to feed point	51.7 $\Omega$ - 3.08j $\Omega$
Return Loss	- 29.3dB

### Antenna Parameters with Body TSL

Impedance, transformed to feed point	48.9 $\Omega$ - 2.07j $\Omega$
Return Loss	- 32.5dB

### General Antenna Parameters and Design

Electrical Delay (one direction)	1.021 ns
----------------------------------	----------

After long term use with 100W radiated power, only a slight warming of the dipole near the feedpoint can be measured.

The dipole is made of standard semirigid coaxial cable. The center conductor of the feeding line is directly connected to the second arm of the dipole. The antenna is therefore short-circuited for DC-signals. On some of the dipoles, small end caps are added to the dipole arms in order to improve matching when loaded according to the position as explained in the "Measurement Conditions" paragraph. The SAR data are not affected by this change. The overall dipole length is still according to the Standard. No excessive force must be applied to the dipole arms, because they might bend or the soldered connections near the feedpoint may be damaged.

### Additional EUT Data

Manufactured by	SPEAG
-----------------	-------



Add: No.51 Xueyuan Road, Haidian District, Beijing, 100191, China  
Tel: +86-10-62304633-2079 Fax: +86-10-62304633-2504  
E-mail: cttl@chinattl.com Http://www.chinattl.cn

Date: 11.21.2016

### DASY5 Validation Report for Head TSL

Test Laboratory: CTTL, Beijing, China

**DUT: Dipole 750 MHz; Type: D750V3; Serial: D750V3 - SN: 1065**

Communication System: UID 0, CW; Frequency: 750 MHz; Duty Cycle: 1:1

Medium parameters used:  $f = 750$  MHz;  $\sigma = 0.906$  S/m;  $\epsilon_r = 41.82$ ;  $\rho = 1000$  kg/m<sup>3</sup>

Phantom section: Center Section

Measurement Standard: DASY5 (IEEE/IEC/ANSI C63.19-2007)

DASY5 Configuration:

- Probe: EX3DV4 - SN7433; ConvF(10.01, 10.01, 10.01); Calibrated: 9/26/2016;
- Sensor-Surface: 2mm (Mechanical Surface Detection)
- Electronics: DAE4 Sn771; Calibrated: 2/2/2016
- Phantom: Triple Flat Phantom 5.1C; Type: QD 000 P51 CA; Serial: 1161/1
- Measurement SW: DASY52, Version 52.8 (8); SEMCAD X Version 14.6.10 (7372)

**Dipole Calibration/Zoom Scan (7x7x7) (7x7x7)/Cube 0:** Measurement grid: dx=5mm, dy=5mm, dz=5mm

Reference Value = 55.09 V/m; Power Drift = 0.00 dB

Peak SAR (extrapolated) = 3.09 W/kg

**SAR(1 g) = 2.11 W/kg; SAR(10 g) = 1.41 W/kg**

Maximum value of SAR (measured) = 2.65 W/kg

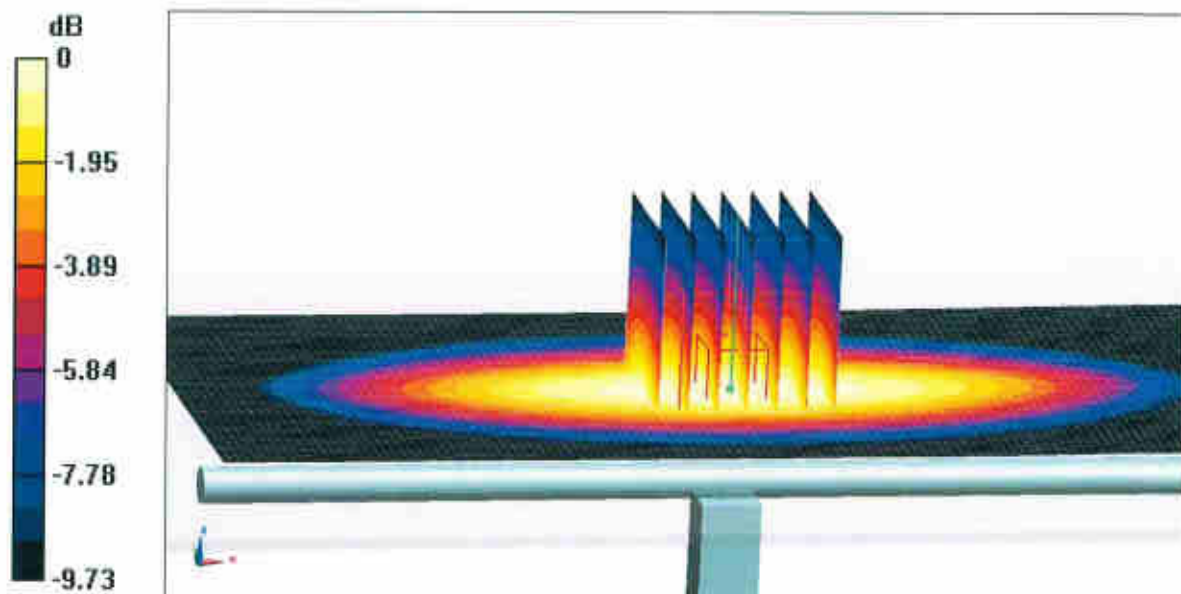

0 dB = 2.65 W/kg = 4.23 dBW/kg



Add: No.51 Xueyuan Road, Haidian District, Beijing, 100191, China  
Tel: +86-10-62304633-2079 Fax: +86-10-62304633-2504  
E-mail: ttl@chinattl.com Http://www.chinattl.cn

### Impedance Measurement Plot for Head TSL

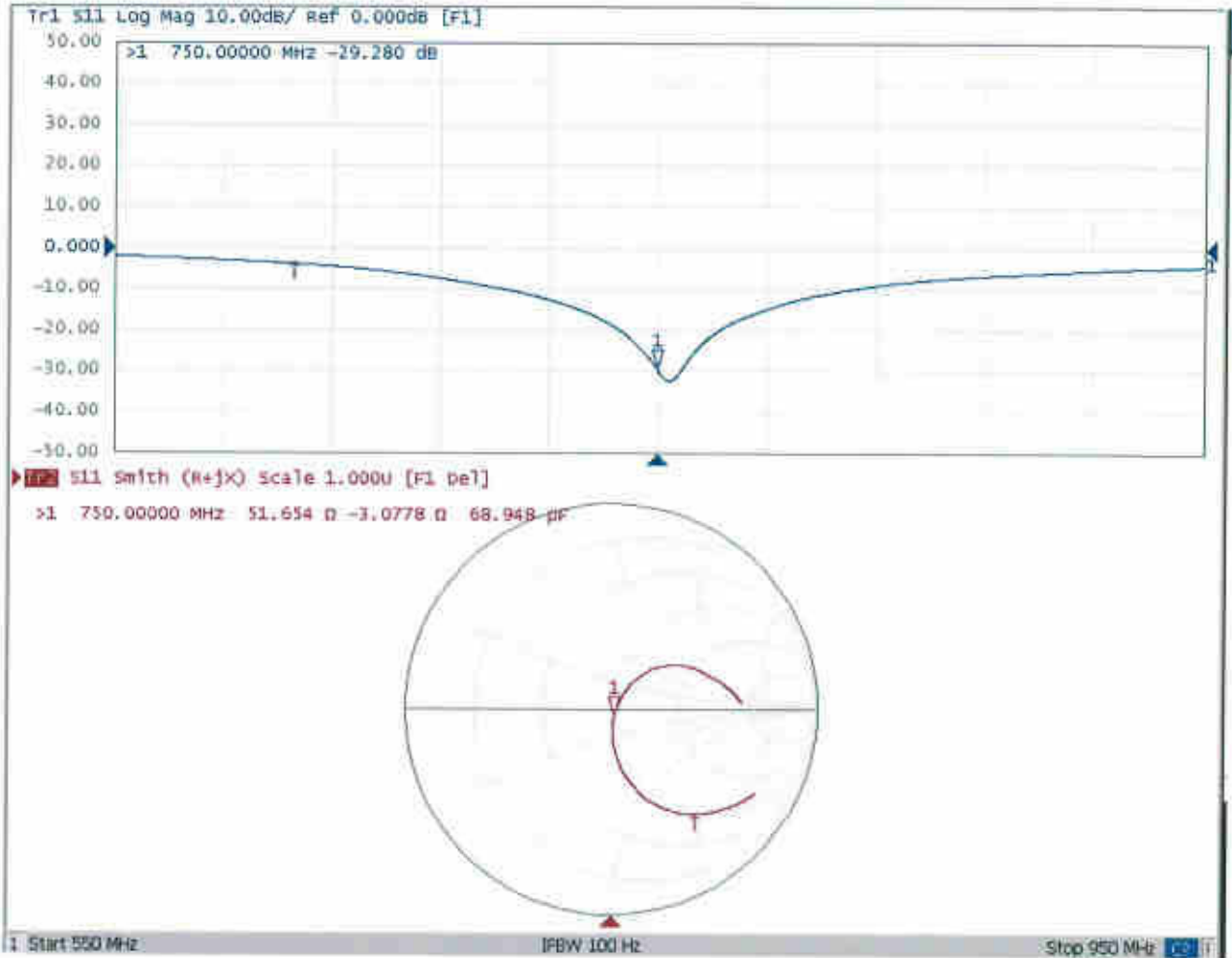



Add: No.51 Xueyuan Road, Haidian District, Beijing, 100191, China  
Tel: +86-10-62304633-2079 Fax: +86-10-62304633-2504  
E-mail: ctll@chinattl.com Http://www.chinattl.cn

### DASY5 Validation Report for Body TSL

Date: 11.21.2016

Test Laboratory: CTTL, Beijing, China

**DUT: Dipole 750 MHz; Type: D750V3; Serial: D750V3 - SN: 1065**

Communication System: UID 0, CW; Frequency: 750 MHz; Duty Cycle: 1:1

Medium parameters used:  $f = 750$  MHz;  $\sigma = 0.945$  S/m;  $\epsilon_r = 54.47$ ;  $\rho = 1000$  kg/m<sup>3</sup>

Phantom section: Left Section

Measurement Standard: DASY5 (IEEE/IEC/ANSI C63.19-2007)

DASY5 Configuration:

- Probe: EX3DV4 - SN7433; ConvF(9.83, 9.83, 9.83); Calibrated: 9/26/2016;
- Sensor-Surface: 2mm (Mechanical Surface Detection)
- Electronics: DAE4 Sn771; Calibrated: 2/2/2016
- Phantom: Triple Flat Phantom 5.1C; Type: QD 000 P51 CA; Serial: 1161/1
- Measurement SW: DASY52, Version 52.8 (8); SEMCAD X Version 14.6.10 (7372)

**Dipole Calibration/Zoom Scan (7x7x7) (7x7x7)/Cube 0:** Measurement grid: dx=5mm, dy=5mm, dz=5mm

Reference Value = 53.84 V/m; Power Drift = 0.00 dB

Peak SAR (extrapolated) = 3.09 W/kg

**SAR(1 g) = 2.16 W/kg; SAR(10 g) = 1.46 W/kg**

Maximum value of SAR (measured) = 2.68 W/kg

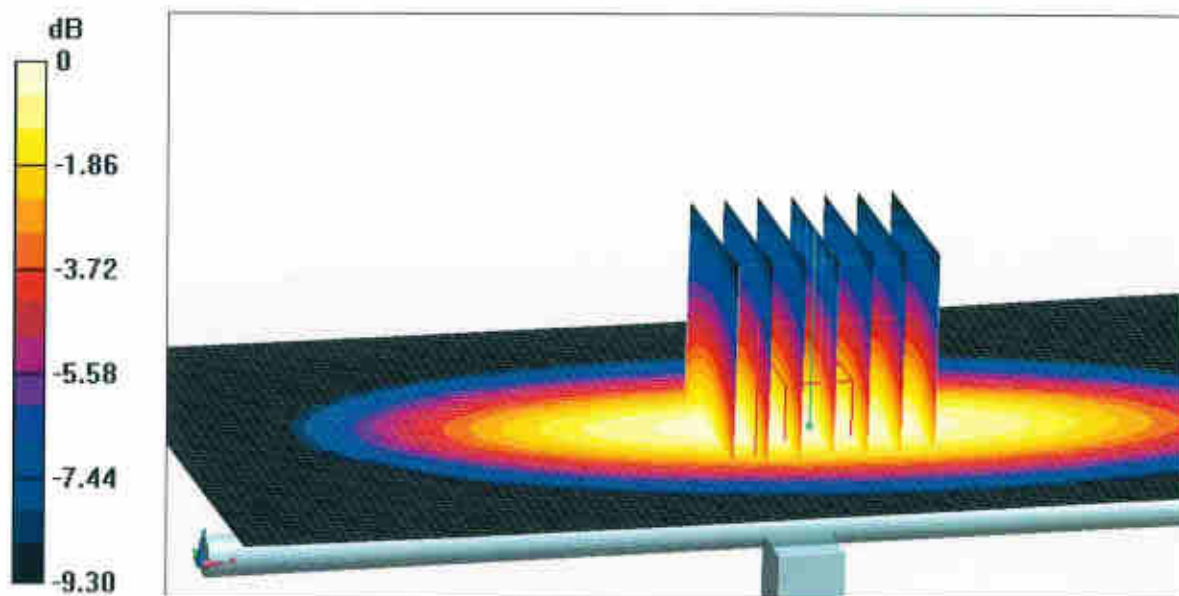

0 dB = 2.68 W/kg = 4.28 dBW/kg



Add: No.51 Xueyuan Road, Haidian District, Beijing, 100191, China  
Tel: +86-10-62304633-2079 Fax: +86-10-62304633-2504  
E-mail: cttl@chinattl.com Http://www.chinattl.cn

### Impedance Measurement Plot for Body TSL

