



Test Mode: TX / IEEE 802.11a / 5300MHz /(CH Mid)

Tested by: Jacksan Luo

Ambient temperature: 24°C

Relative humidity: 52% RH

Date: November 7, 2016

Frequency (MHz)	Reading (dBuV)	Correction Factor (dB/m)	Result (dBuV/m)	Limit (dBuV/m)	Margin (dB)	Antenna Pole (V/H)	Remark
7740.000	31.00	9.14	40.14	74.00	-33.86	V	peak
8148.000	31.05	9.57	40.62	74.00	-33.38	V	peak
9804.000	30.43	11.42	41.85	74.00	-32.15	V	peak
10392.000	30.54	13.20	43.74	74.00	-30.26	V	peak
11244.000	30.13	14.97	45.10	74.00	-28.90	V	peak
12960.000	29.15	17.82	46.97	74.00	-27.03	V	peak
7368.000	30.64	8.42	39.06	74.00	-34.94	H	Peak
8196.000	30.96	9.54	40.50	74.00	-33.50	H	Peak
9468.000	31.06	10.45	41.51	74.00	-32.49	H	Peak
10644.000	30.95	13.98	44.93	74.00	-29.07	H	peak
11268.000	30.52	14.96	45.48	74.00	-28.52	H	peak
13272.000	28.74	18.67	47.41	74.00	-26.59	H	peak

Remark:

1. Measuring frequencies from 1 GHz to the 10th harmonic of highest fundamental frequency.
2. Radiated emissions measured in frequency above 1000MHz were made with an instrument using peak/average detector mode.
3. Average test would be performed if the peak result were greater than the average limit.
4. Data of measurement within this frequency range shown " --- " in the table above means the reading of emissions are attenuated more than 20dB below the permissible limits or the field strength is too small to be measured.
5. Measurements above show only up to 6 maximum emissions noted, or would be lesser, with " N/A " remark, if no specific emissions from the EUT are recorded (ie: margin>20dB from the applicable limit) and considered that's already beyond the background noise floor.
6. Margin (dB) = Remark result (dBuV/m) – Average limit (dBuV/m).



Test Mode: TX / IEEE 802.11a / 5320MHz /(CH High)

Tested by: Jacksan Luo

Ambient temperature: 24°C Relative humidity: 52% RH

Date: November 7, 2016

Frequency (MHz)	Reading (dBuV)	Correction Factor (dB/m)	Result (dBuV/m)	Limit (dBuV/m)	Margin (dB)	Antenna Pole (V/H)	Remark
7236.000	30.45	8.16	38.61	74.00	-35.39	V	peak
8208.000	30.87	9.54	40.41	74.00	-33.59	V	peak
9696.000	30.61	11.10	41.71	74.00	-32.29	V	peak
10776.000	30.06	14.39	44.45	74.00	-29.55	V	peak
12276.000	30.02	15.55	45.57	74.00	-28.43	V	peak
13380.000	28.39	18.95	47.34	74.00	-26.66	V	peak
7524.000	30.80	8.72	39.52	74.00	-34.48	H	Peak
8136.000	30.67	9.58	40.25	74.00	-33.75	H	Peak
9996.000	30.62	11.97	42.59	74.00	-31.41	H	Peak
10584.000	30.12	13.79	43.91	74.00	-30.09	H	peak
11160.000	30.22	15.01	45.23	74.00	-28.77	H	peak
12840.000	29.56	17.42	46.98	74.00	-27.02	H	peak

Remark:

1. Measuring frequencies from 1 GHz to the 10th harmonic of highest fundamental frequency.
2. Radiated emissions measured in frequency above 1000MHz were made with an instrument using peak/average detector mode.
3. Average test would be performed if the peak result were greater than the average limit.
4. Data of measurement within this frequency range shown " --- " in the table above means the reading of emissions are attenuated more than 20dB below the permissible limits or the field strength is too small to be measured.
5. Measurements above show only up to 6 maximum emissions noted, or would be lesser, with " N/A " remark, if no specific emissions from the EUT are recorded (ie: margin>20dB from the applicable limit) and considered that's already beyond the background noise floor.
6. Margin (dB) = Remark result (dBuV/m) – Average limit (dBuV/m).



Test Mode: TX / IEEE 802.11a / 5500MHz /(CH Low)

Tested by: Jacksan Luo

Ambient temperature: 24°C

Relative humidity: 52% RH

Date: November 7, 2016

Frequency (MHz)	Reading (dBuV)	Correction Factor (dB/m)	Result (dBuV/m)	Limit (dBuV/m)	Margin (dB)	Antenna Pole (V/H)	Remark
7092.000	30.67	7.88	38.55	74.00	-35.45	V	peak
8160.000	30.62	9.56	40.18	74.00	-33.82	V	peak
9312.000	30.82	10.00	40.82	74.00	-33.18	V	peak
10380.000	30.57	13.16	43.73	74.00	-30.27	V	peak
11148.000	30.33	15.01	45.34	74.00	-28.66	V	peak
13080.000	28.86	18.16	47.02	74.00	-26.98	V	peak
7008.000	30.96	7.72	38.68	74.00	-35.32	H	Peak
8184.000	31.01	9.55	40.56	74.00	-33.44	H	Peak
9708.000	30.73	11.14	41.87	74.00	-32.13	H	Peak
10620.000	30.39	13.90	44.29	74.00	-29.71	H	peak
12252.000	29.93	15.47	45.40	74.00	-28.60	H	peak
12936.000	29.10	17.74	46.84	74.00	-27.16	H	peak

Remark:

1. Measuring frequencies from 1 GHz to the 10th harmonic of highest fundamental frequency.
2. Radiated emissions measured in frequency above 1000MHz were made with an instrument using peak/average detector mode.
3. Average test would be performed if the peak result were greater than the average limit.
4. Data of measurement within this frequency range shown " --- " in the table above means the reading of emissions are attenuated more than 20dB below the permissible limits or the field strength is too small to be measured.
5. Measurements above show only up to 6 maximum emissions noted, or would be lesser, with " N/A " remark, if no specific emissions from the EUT are recorded (ie: margin>20dB from the applicable limit) and considered that's already beyond the background noise floor.
6. Margin (dB) = Remark result (dBuV/m) – Average limit (dBuV/m).



Test Mode: TX / IEEE 802.11a / 5580MHz /(CH Mid)

Tested by: Jacksan Luo

Ambient temperature: 24°C

Relative humidity: 52% RH

Date: November 7, 2016

Frequency (MHz)	Reading (dBuV)	Correction Factor (dB/m)	Result (dBuV/m)	Limit (dBuV/m)	Margin (dB)	Antenna Pole (V/H)	Remark
7128.000	30.73	7.95	38.68	74.00	-35.32	V	peak
8172.000	30.78	9.56	40.34	74.00	-33.66	V	peak
9180.000	30.70	9.62	40.32	74.00	-33.68	V	peak
10608.000	30.12	13.86	43.98	74.00	-30.02	V	peak
11736.000	30.50	14.76	45.26	74.00	-28.74	V	peak
12936.000	29.36	17.74	47.10	74.00	-26.90	V	peak
7020.000	30.72	7.74	38.46	74.00	-35.54	H	Peak
8136.000	30.82	9.58	40.40	74.00	-33.60	H	Peak
9480.000	31.43	10.48	41.91	74.00	-32.09	H	peak
11136.000	30.01	15.02	45.03	74.00	-28.97	H	peak
12516.000	29.72	16.35	46.07	74.00	-27.93	H	peak
12972.000	29.35	17.86	47.21	74.00	-26.79	H	peak

Remark:

1. Measuring frequencies from 1 GHz to the 10th harmonic of highest fundamental frequency.
2. Radiated emissions measured in frequency above 1000MHz were made with an instrument using peak/average detector mode.
3. Average test would be performed if the peak result were greater than the average limit.
4. Data of measurement within this frequency range shown " --- " in the table above means the reading of emissions are attenuated more than 20dB below the permissible limits or the field strength is too small to be measured.
5. Measurements above show only up to 6 maximum emissions noted, or would be lesser, with " N/A " remark, if no specific emissions from the EUT are recorded (ie: margin>20dB from the applicable limit) and considered that's already beyond the background noise floor.
6. Margin (dB) = Remark result (dBuV/m) – Average limit (dBuV/m).



Test Mode: TX / IEEE 802.11a / 5700MHz /(CH High)

Tested by: Jacksan Luo

Ambient temperature: 24°C

Relative humidity: 52% RH

Date: November 7, 2016

Frequency (MHz)	Reading (dBuV)	Correction Factor (dB/m)	Result (dBuV/m)	Limit (dBuV/m)	Margin (dB)	Antenna Pole (V/H)	Remark
7092.000	30.82	7.88	38.70	74.00	-35.30	V	peak
8424.000	30.89	9.42	40.31	74.00	-33.69	V	peak
10608.000	30.24	13.86	44.10	74.00	-29.90	V	peak
11136.000	30.21	15.02	45.23	74.00	-28.77	V	peak
12264.000	30.37	15.51	45.88	74.00	-28.12	V	peak
13080.000	29.07	18.16	47.23	74.00	-26.77	V	peak
7032.000	30.84	7.76	38.60	74.00	-35.40	H	Peak
8184.000	30.87	9.55	40.42	74.00	-33.58	H	Peak
9996.000	30.68	11.97	42.65	74.00	-31.35	H	Peak
10632.000	30.31	13.94	44.25	74.00	-29.75	H	peak
11868.000	30.44	14.70	45.14	74.00	-28.86	H	peak
13236.000	28.58	18.57	47.15	74.00	-26.85	H	peak

Remark:

1. Measuring frequencies from 1 GHz to the 10th harmonic of highest fundamental frequency.
2. Radiated emissions measured in frequency above 1000MHz were made with an instrument using peak/average detector mode.
3. Average test would be performed if the peak result were greater than the average limit.
4. Data of measurement within this frequency range shown " --- " in the table above means the reading of emissions are attenuated more than 20dB below the permissible limits or the field strength is too small to be measured.
5. Measurements above show only up to 6 maximum emissions noted, or would be lesser, with " N/A " remark, if no specific emissions from the EUT are recorded (ie: margin>20dB from the applicable limit) and considered that's already beyond the background noise floor.
6. Margin (dB) = Remark result (dBuV/m) – Average limit (dBuV/m).



Test Mode: TX / IEEE 802.11a / 5745MHz /(CH Low)

Tested by: Jacksan Luo

Ambient temperature: 24°C

Relative humidity: 52% RH

Date: November 7, 2016

Frequency (MHz)	Reading (dBuV)	Correction Factor (dB/m)	Result (dBuV/m)	Limit (dBuV/m)	Margin (dB)	Antenna Pole (V/H)	Remark
7464.000	30.98	8.60	39.58	74.00	-34.42	V	peak
8088.000	30.60	9.60	40.20	74.00	-33.80	V	peak
9948.000	30.80	11.83	42.63	74.00	-31.37	V	peak
10944.000	29.93	14.91	44.84	74.00	-29.16	V	peak
12312.000	30.34	15.67	46.01	74.00	-27.99	V	peak
13308.000	28.72	18.76	47.48	74.00	-26.52	V	peak
7008.000	30.28	7.72	38.00	74.00	-36.00	H	Peak
8160.000	30.62	9.56	40.18	74.00	-33.82	H	Peak
9600.000	30.39	10.83	41.22	74.00	-32.78	H	Peak
10164.000	30.15	12.49	42.64	74.00	-31.36	H	peak
11400.000	30.24	14.90	45.14	74.00	-28.86	H	peak
13032.000	29.37	18.03	47.40	74.00	-26.60	H	peak

Remark:

1. Measuring frequencies from 1 GHz to the 10th harmonic of highest fundamental frequency.
2. Radiated emissions measured in frequency above 1000MHz were made with an instrument using peak/average detector mode.
3. Average test would be performed if the peak result were greater than the average limit.
4. Data of measurement within this frequency range shown " --- " in the table above means the reading of emissions are attenuated more than 20dB below the permissible limits or the field strength is too small to be measured.
5. Measurements above show only up to 6 maximum emissions noted, or would be lesser, with " N/A " remark, if no specific emissions from the EUT are recorded (ie: margin>20dB from the applicable limit) and considered that's already beyond the background noise floor.
6. Margin (dB) = Remark result (dBuV/m) – Average limit (dBuV/m).



Test Mode: TX / IEEE 802.11a / 5785MHz /(CH Mid)

Tested by: Jacksan Luo

Ambient temperature: 24°C

Relative humidity: 52% RH

Date: November 7, 2016

Frequency (MHz)	Reading (dBuV)	Correction Factor (dB/m)	Result (dBuV/m)	Limit (dBuV/m)	Margin (dB)	Antenna Pole (V/H)	Remark
7212.000	30.36	8.11	38.47	74.00	-35.53	V	peak
7488.000	30.83	8.65	39.48	74.00	-34.52	V	peak
9420.000	31.09	10.31	41.40	74.00	-32.60	V	peak
10440.000	30.57	13.34	43.91	74.00	-30.09	V	peak
11652.000	30.33	14.79	45.12	74.00	-28.88	V	peak
12900.000	29.36	17.62	46.98	74.00	-27.02	V	peak
7092.000	31.00	7.88	38.88	74.00	-35.12	H	Peak
8136.000	30.77	9.58	40.35	74.00	-33.65	H	Peak
9348.000	30.79	10.10	40.89	74.00	-33.11	H	Peak
10632.000	30.29	13.94	44.23	74.00	-29.77	H	peak
11136.000	30.40	15.02	45.42	74.00	-28.58	H	peak
13056.000	28.64	18.10	46.74	74.00	-27.26	H	peak

Remark:

1. Measuring frequencies from 1 GHz to the 10th harmonic of highest fundamental frequency.
2. Radiated emissions measured in frequency above 1000MHz were made with an instrument using peak/average detector mode.
3. Average test would be performed if the peak result were greater than the average limit.
4. Data of measurement within this frequency range shown " --- " in the table above means the reading of emissions are attenuated more than 20dB below the permissible limits or the field strength is too small to be measured.
5. Measurements above show only up to 6 maximum emissions noted, or would be lesser, with " N/A " remark, if no specific emissions from the EUT are recorded (ie: margin>20dB from the applicable limit) and considered that's already beyond the background noise floor.
6. Margin (dB) = Remark result (dBuV/m) – Average limit (dBuV/m).



Test Mode: TX / IEEE 802.11a / 5825MHz /(CH High)

Tested by: Jacksan Luo

Ambient temperature: 24°C

Relative humidity: 52% RH

Date: November 7, 2016

Frequency (MHz)	Reading (dBuV)	Correction Factor (dB/m)	Result (dBuV/m)	Limit (dBuV/m)	Margin (dB)	Antenna Pole (V/H)	Remark
6780.000	30.40	7.34	37.74	74.00	-36.26	V	peak
8172.000	30.68	9.56	40.24	74.00	-33.76	V	peak
9672.000	31.17	11.04	42.21	74.00	-31.79	V	peak
10896.000	29.83	14.76	44.59	74.00	-29.41	V	peak
11292.000	30.06	14.95	45.01	74.00	-28.99	V	peak
13116.000	28.50	18.26	46.76	74.00	-27.24	V	peak
7068.000	30.46	7.83	38.29	74.00	-35.71	H	Peak
7716.000	30.81	9.10	39.91	74.00	-34.09	H	Peak
9420.000	30.28	10.31	40.59	74.00	-33.41	H	Peak
10800.000	29.95	14.46	44.41	74.00	-29.59	H	peak
12624.000	29.51	16.71	46.22	74.00	-27.78	H	peak
13284.000	28.42	18.70	47.12	74.00	-26.88	H	peak

Remark:

1. Measuring frequencies from 1 GHz to the 10th harmonic of highest fundamental frequency.
2. Radiated emissions measured in frequency above 1000MHz were made with an instrument using peak/average detector mode.
3. Average test would be performed if the peak result were greater than the average limit.
4. Data of measurement within this frequency range shown " --- " in the table above means the reading of emissions are attenuated more than 20dB below the permissible limits or the field strength is too small to be measured.
5. Measurements above show only up to 6 maximum emissions noted, or would be lesser, with " N/A " remark, if no specific emissions from the EUT are recorded (ie: margin>20dB from the applicable limit) and considered that's already beyond the background noise floor.
6. Margin (dB) = Remark result (dBuV/m) – Average limit (dBuV/m).



Test Mode: TX / IEEE 802.11n HT 20 MHz / 5180MHz / (CH Low) **Tested by:** Jacksan Luo

Ambient temperature: 24°C **Relative humidity:** 52% RH **Date:** November 7, 2016

Frequency (MHz)	Reading (dBuV)	Correction Factor (dB/m)	Result (dBuV/m)	Limit (dBuV/m)	Margin (dB)	Antenna Pole (V/H)	Remark
7200.000	30.62	8.09	38.71	74.00	-35.29	V	peak
8244.000	30.62	9.52	40.14	74.00	-33.86	V	peak
9876.000	30.32	11.62	41.94	74.00	-32.06	V	peak
10884.000	29.73	14.72	44.45	74.00	-29.55	V	peak
11280.000	30.52	14.96	45.48	74.00	-28.52	V	peak
12960.000	29.27	17.82	47.09	74.00	-26.91	V	peak
7680.000	31.02	9.03	40.05	74.00	-33.95	H	Peak
8244.000	30.70	9.52	40.22	74.00	-33.78	H	Peak
10356.000	30.87	13.08	43.95	74.00	-30.05	H	Peak
11280.000	30.36	14.96	45.32	74.00	-28.68	H	peak
12228.000	30.07	15.39	45.46	74.00	-28.54	H	peak
12948.000	29.71	17.78	47.49	74.00	-26.51	H	peak

Remark:

1. Measuring frequencies from 1 GHz to the 10th harmonic of highest fundamental frequency.
2. Radiated emissions measured in frequency above 1000MHz were made with an instrument using peak/average detector mode.
3. Average test would be performed if the peak result were greater than the average limit.
4. Data of measurement within this frequency range shown " --- " in the table above means the reading of emissions are attenuated more than 20dB below the permissible limits or the field strength is too small to be measured.
5. Measurements above show only up to 6 maximum emissions noted, or would be lesser, with " N/A " remark, if no specific emissions from the EUT are recorded (ie: margin>20dB from the applicable limit) and considered that's already beyond the background noise floor.
6. Margin (dB) = Remark result (dBuV/m) – Average limit (dBuV/m).



Test Mode: TX / IEEE 802.11n HT 20 MHz / 5200MHz /(CH Mid) Tested by: Jacksan Luo

Ambient temperature: 24°C Relative humidity: 52% RH Date: November 7, 2016

Frequency (MHz)	Reading (dBuV)	Correction Factor (dB/m)	Result (dBuV/m)	Limit (dBuV/m)	Margin (dB)	Antenna Pole (V/H)	Remark
7632.000	31.16	8.93	40.09	74.00	-33.91	V	peak
8964.000	31.03	9.12	40.15	74.00	-33.85	V	peak
9960.000	31.18	11.86	43.04	74.00	-30.96	V	peak
10908.000	30.23	14.79	45.02	74.00	-28.98	V	peak
11256.000	30.25	14.97	45.22	74.00	-28.78	V	peak
13296.000	28.57	18.73	47.30	74.00	-26.70	V	peak
6408.000	30.97	6.74	37.71	74.00	-36.29	H	Peak
8136.000	30.66	9.58	40.24	74.00	-33.76	H	Peak
9456.000	30.66	10.41	41.07	74.00	-32.93	H	Peak
11004.000	29.49	15.08	44.57	74.00	-29.43	H	peak
11904.000	30.33	14.68	45.01	74.00	-28.99	H	peak
13176.000	28.48	18.41	46.89	74.00	-27.11	H	peak

Remark:

1. Measuring frequencies from 1 GHz to the 10th harmonic of highest fundamental frequency.
2. Radiated emissions measured in frequency above 1000MHz were made with an instrument using peak/average detector mode.
3. Average test would be performed if the peak result were greater than the average limit.
4. Data of measurement within this frequency range shown " --- " in the table above means the reading of emissions are attenuated more than 20dB below the permissible limits or the field strength is too small to be measured.
5. Measurements above show only up to 6 maximum emissions noted, or would be lesser, with " N/A " remark, if no specific emissions from the EUT are recorded (ie: margin>20dB from the applicable limit) and considered that's already beyond the background noise floor.
6. Margin (dB) = Remark result (dBuV/m) – Average limit (dBuV/m).



Test Mode: TX / IEEE 802.11n HT 20 MHz / 5240MHz /(CH High) Tested by: Jacksan Luo

Ambient temperature: 24°C Relative humidity: 52% RH Date: November 7, 2016

Frequency (MHz)	Reading (dBuV)	Correction Factor (dB/m)	Result (dBuV/m)	Limit (dBuV/m)	Margin (dB)	Antenna Pole (V/H)	Remark
7272.000	30.58	8.23	38.81	74.00	-35.19	V	peak
8136.000	30.42	9.58	40.00	74.00	-34.00	V	peak
10008.000	30.91	12.00	42.91	74.00	-31.09	V	peak
11136.000	30.01	15.02	45.03	74.00	-28.97	V	peak
12576.000	29.56	16.55	46.11	74.00	-27.89	V	peak
13272.000	28.47	18.67	47.14	74.00	-26.86	V	peak
7704.000	31.10	9.07	40.17	74.00	-33.83	H	Peak
9444.000	31.00	10.38	41.38	74.00	-32.62	H	Peak
10608.000	30.24	13.86	44.10	74.00	-29.90	H	Peak
11520.000	30.38	14.85	45.23	74.00	-28.77	H	peak
12540.000	29.31	16.43	45.74	74.00	-28.26	H	peak
13296.000	28.27	18.73	47.00	74.00	-27.00	H	peak

Remark:

1. Measuring frequencies from 1 GHz to the 10th harmonic of highest fundamental frequency.
2. Radiated emissions measured in frequency above 1000MHz were made with an instrument using peak/average detector mode.
3. Average test would be performed if the peak result were greater than the average limit.
4. Data of measurement within this frequency range shown " --- " in the table above means the reading of emissions are attenuated more than 20dB below the permissible limits or the field strength is too small to be measured.
5. Measurements above show only up to 6 maximum emissions noted, or would be lesser, with " N/A " remark, if no specific emissions from the EUT are recorded (ie: margin>20dB from the applicable limit) and considered that's already beyond the background noise floor.
6. Margin (dB) = Remark result (dBuV/m) – Average limit (dBuV/m).



Test Mode: TX / IEEE 802.11n HT 20 MHz / 5260MHz / (CH Low) **Tested by:** Jacksan Luo

Ambient temperature: 24°C **Relative humidity:** 52% RH **Date:** November 7, 2016

Frequency (MHz)	Reading (dBuV)	Correction Factor (dB/m)	Result (dBuV/m)	Limit (dBuV/m)	Margin (dB)	Antenna Pole (V/H)	Remark
7668.000	31.32	9.00	40.32	74.00	-33.68	V	peak
8412.000	30.96	9.42	40.38	74.00	-33.62	V	peak
10008.000	30.98	12.00	42.98	74.00	-31.02	V	peak
10764.000	30.15	14.35	44.50	74.00	-29.50	V	peak
12252.000	30.48	15.47	45.95	74.00	-28.05	V	peak
13260.000	28.54	18.63	47.17	74.00	-26.83	V	peak
6864.000	30.57	7.48	38.05	74.00	-35.95	H	Peak
8064.000	30.58	9.61	40.19	74.00	-33.81	H	Peak
10488.000	29.83	13.49	43.32	74.00	-30.68	H	Peak
11136.000	30.47	15.02	45.49	74.00	-28.51	H	peak
12600.000	30.17	16.63	46.80	74.00	-27.20	H	peak
13080.000	29.09	18.16	47.25	74.00	-26.75	H	peak

Remark:

1. Measuring frequencies from 1 GHz to the 10th harmonic of highest fundamental frequency.
2. Radiated emissions measured in frequency above 1000MHz were made with an instrument using peak/average detector mode.
3. Average test would be performed if the peak result were greater than the average limit.
4. Data of measurement within this frequency range shown " --- " in the table above means the reading of emissions are attenuated more than 20dB below the permissible limits or the field strength is too small to be measured.
5. Measurements above show only up to 6 maximum emissions noted, or would be lesser, with " N/A " remark, if no specific emissions from the EUT are recorded (ie: margin>20dB from the applicable limit) and considered that's already beyond the background noise floor.
6. Margin (dB) = Remark result (dBuV/m) – Average limit (dBuV/m).



Test Mode: TX / IEEE 802.11n HT 20 MHz / 5300MHz /(CH Mid) **Tested by:** Jacksan Luo

Ambient temperature: 24°C **Relative humidity:** 52% RH **Date:** November 7, 2016

Frequency (MHz)	Reading (dBuV)	Correction Factor (dB/m)	Result (dBuV/m)	Limit (dBuV/m)	Margin (dB)	Antenna Pole (V/H)	Remark
7680.000	31.16	9.03	40.19	74.00	-33.81	V	peak
8208.000	30.82	9.54	40.36	74.00	-33.64	V	peak
9696.000	30.57	11.10	41.67	74.00	-32.33	V	peak
10416.000	30.24	13.27	43.51	74.00	-30.49	V	peak
11136.000	30.53	15.02	45.55	74.00	-28.45	V	peak
12924.000	29.12	17.70	46.82	74.00	-27.18	V	peak
7644.000	31.01	8.96	39.97	74.00	-34.03	H	Peak
8148.000	30.71	9.57	40.28	74.00	-33.72	H	Peak
9768.000	30.78	11.31	42.09	74.00	-31.91	H	Peak
10920.000	29.75	14.83	44.58	74.00	-29.42	H	peak
12252.000	30.25	15.47	45.72	74.00	-28.28	H	peak
13056.000	28.88	18.10	46.98	74.00	-27.02	H	peak

Remark:

1. Measuring frequencies from 1 GHz to the 10th harmonic of highest fundamental frequency.
2. Radiated emissions measured in frequency above 1000MHz were made with an instrument using peak/average detector mode.
3. Average test would be performed if the peak result were greater than the average limit.
4. Data of measurement within this frequency range shown " --- " in the table above means the reading of emissions are attenuated more than 20dB below the permissible limits or the field strength is too small to be measured.
5. Measurements above show only up to 6 maximum emissions noted, or would be lesser, with " N/A " remark, if no specific emissions from the EUT are recorded (ie: margin>20dB from the applicable limit) and considered that's already beyond the background noise floor.
6. Margin (dB) = Remark result (dBuV/m) – Average limit (dBuV/m).



Test Mode: TX / IEEE 802.11n HT 20 MHz / 5320MHz /(CH High) **Tested by:** Jacksan Luo

Ambient temperature: 24°C **Relative humidity:** 52% RH **Date:** November 7, 2016

Frequency (MHz)	Reading (dBuV)	Correction Factor (dB/m)	Result (dBuV/m)	Limit (dBuV/m)	Margin (dB)	Antenna Pole (V/H)	Remark
7476.000	31.25	8.63	39.88	74.00	-34.12	V	peak
8172.000	30.60	9.56	40.16	74.00	-33.84	V	peak
10116.000	30.22	12.34	42.56	74.00	-31.44	V	peak
11148.000	29.97	15.01	44.98	74.00	-29.02	V	peak
11676.000	30.55	14.78	45.33	74.00	-28.67	V	peak
12972.000	29.49	17.86	47.35	74.00	-26.65	V	peak
6684.000	30.65	7.19	37.84	74.00	-36.16	H	Peak
7584.000	30.91	8.84	39.75	74.00	-34.25	H	Peak
8124.000	30.64	9.58	40.22	74.00	-33.78	H	Peak
10536.000	30.18	13.64	43.82	74.00	-30.18	H	peak
11520.000	30.65	14.85	45.50	74.00	-28.50	H	peak
12876.000	29.51	17.54	47.05	74.00	-26.95	H	peak

Remark:

1. Measuring frequencies from 1 GHz to the 10th harmonic of highest fundamental frequency.
2. Radiated emissions measured in frequency above 1000MHz were made with an instrument using peak/average detector mode.
3. Average test would be performed if the peak result were greater than the average limit.
4. Data of measurement within this frequency range shown " --- " in the table above means the reading of emissions are attenuated more than 20dB below the permissible limits or the field strength is too small to be measured.
5. Measurements above show only up to 6 maximum emissions noted, or would be lesser, with " N/A " remark, if no specific emissions from the EUT are recorded (ie: margin>20dB from the applicable limit) and considered that's already beyond the background noise floor.
6. Margin (dB) = Remark result (dBuV/m) – Average limit (dBuV/m).



Test Mode: TX / IEEE 802.11n HT 20 MHz / 5500MHz / (CH Low) **Tested by:** Jacksan Luo

Ambient temperature: 24°C **Relative humidity:** 52% RH **Date:** November 7, 2016

Frequency (MHz)	Reading (dBuV)	Correction Factor (dB/m)	Result (dBuV/m)	Limit (dBuV/m)	Margin (dB)	Antenna Pole (V/H)	Remark
7140.000	31.03	7.97	39.00	74.00	-35.00	V	peak
8088.000	30.96	9.60	40.56	74.00	-33.44	V	peak
8412.000	30.80	9.42	40.22	74.00	-33.78	V	peak
10368.000	30.17	13.12	43.29	74.00	-30.71	V	peak
11712.000	30.56	14.77	45.33	74.00	-28.67	V	peak
13344.000	28.59	18.85	47.44	74.00	-26.56	V	peak
7416.000	30.78	8.51	39.29	74.00	-34.71	H	Peak
8400.000	30.79	9.43	40.22	74.00	-33.78	H	Peak
9720.000	30.58	11.17	41.75	74.00	-32.25	H	Peak
10584.000	30.36	13.79	44.15	74.00	-29.85	H	peak
11160.000	30.32	15.01	45.33	74.00	-28.67	H	peak
13116.000	29.18	18.26	47.44	74.00	-26.56	H	peak

Remark:

1. Measuring frequencies from 1 GHz to the 10th harmonic of highest fundamental frequency.
2. Radiated emissions measured in frequency above 1000MHz were made with an instrument using peak/average detector mode.
3. Average test would be performed if the peak result were greater than the average limit.
4. Data of measurement within this frequency range shown " --- " in the table above means the reading of emissions are attenuated more than 20dB below the permissible limits or the field strength is too small to be measured.
5. Measurements above show only up to 6 maximum emissions noted, or would be lesser, with " N/A " remark, if no specific emissions from the EUT are recorded (ie: margin>20dB from the applicable limit) and considered that's already beyond the background noise floor.
6. Margin (dB) = Remark result (dBuV/m) – Average limit (dBuV/m).



Test Mode: TX / IEEE 802.11n HT 20 MHz / 5580MHz /(CH Mid) **Tested by:** Jacksan Luo

Ambient temperature: 24°C **Relative humidity:** 52% RH **Date:** November 7, 2016

Frequency (MHz)	Reading (dBuV)	Correction Factor (dB/m)	Result (dBuV/m)	Limit (dBuV/m)	Margin (dB)	Antenna Pole (V/H)	Remark
7464.000	31.01	8.60	39.61	74.00	-34.39	V	peak
8196.000	30.76	9.54	40.30	74.00	-33.70	V	peak
10020.000	31.05	12.04	43.09	74.00	-30.91	V	peak
11040.000	29.80	15.06	44.86	74.00	-29.14	V	peak
12252.000	30.01	15.47	45.48	74.00	-28.52	V	peak
13260.000	28.53	18.63	47.16	74.00	-26.84	V	peak
7512.000	30.83	8.70	39.53	74.00	-34.47	H	Peak
8184.000	30.86	9.55	40.41	74.00	-33.59	H	Peak
9468.000	30.82	10.45	41.27	74.00	-32.73	H	Peak
10188.000	30.29	12.56	42.85	74.00	-31.15	H	peak
11880.000	30.46	14.69	45.15	74.00	-28.85	H	peak
13308.000	28.37	18.76	47.13	74.00	-26.87	H	peak

Remark:

1. Measuring frequencies from 1 GHz to the 10th harmonic of highest fundamental frequency.
2. Radiated emissions measured in frequency above 1000MHz were made with an instrument using peak/average detector mode.
3. Average test would be performed if the peak result were greater than the average limit.
4. Data of measurement within this frequency range shown " --- " in the table above means the reading of emissions are attenuated more than 20dB below the permissible limits or the field strength is too small to be measured.
5. Measurements above show only up to 6 maximum emissions noted, or would be lesser, with " N/A " remark, if no specific emissions from the EUT are recorded (ie: margin>20dB from the applicable limit) and considered that's already beyond the background noise floor.
6. Margin (dB) = Remark result (dBuV/m) – Average limit (dBuV/m).



Test Mode: TX / IEEE 802.11n HT 20 MHz / 5700MHz /(CH High) **Tested by:** Jacksan Luo

Ambient temperature: 24°C **Relative humidity:** 52% RH **Date:** November 7, 2016

Frequency (MHz)	Reading (dBuV)	Correction Factor (dB/m)	Result (dBuV/m)	Limit (dBuV/m)	Margin (dB)	Antenna Pole (V/H)	Remark
7392.000	30.52	8.46	38.98	74.00	-35.02	V	peak
8100.000	30.63	9.60	40.23	74.00	-33.77	V	peak
9972.000	30.55	11.90	42.45	74.00	-31.55	V	peak
10632.000	30.82	13.94	44.76	74.00	-29.24	V	peak
11832.000	30.58	14.71	45.29	74.00	-28.71	V	peak
13236.000	28.68	18.57	47.25	74.00	-26.75	V	peak
7116.000	30.80	7.93	38.73	74.00	-35.27	H	Peak
8052.000	31.02	9.62	40.64	74.00	-33.36	H	Peak
9060.000	30.87	9.27	40.14	74.00	-33.86	H	Peak
10332.000	30.25	13.01	43.26	74.00	-30.74	H	peak
11136.000	30.23	15.02	45.25	74.00	-28.75	H	peak
12912.000	29.47	17.66	47.13	74.00	-26.87	H	peak

Remark:

1. Measuring frequencies from 1 GHz to the 10th harmonic of highest fundamental frequency.
2. Radiated emissions measured in frequency above 1000MHz were made with an instrument using peak/average detector mode.
3. Average test would be performed if the peak result were greater than the average limit.
4. Data of measurement within this frequency range shown " --- " in the table above means the reading of emissions are attenuated more than 20dB below the permissible limits or the field strength is too small to be measured.
5. Measurements above show only up to 6 maximum emissions noted, or would be lesser, with " N/A " remark, if no specific emissions from the EUT are recorded (ie: margin>20dB from the applicable limit) and considered that's already beyond the background noise floor.
6. Margin (dB) = Remark result (dBuV/m) – Average limit (dBuV/m).



Test Mode: TX / IEEE 802.11n HT 20 MHz / 5745MHz /(CH Low) **Tested by:** Jacksan Luo

Ambient temperature: 24°C **Relative humidity:** 52% RH **Date:** November 7, 2016

Frequency (MHz)	Reading (dBuV)	Correction Factor (dB/m)	Result (dBuV/m)	Limit (dBuV/m)	Margin (dB)	Antenna Pole (V/H)	Remark
7416.000	30.72	8.51	39.23	74.00	-34.77	V	peak
8088.000	30.77	9.60	40.37	74.00	-33.63	V	peak
9744.000	30.73	11.24	41.97	74.00	-32.03	V	peak
10848.000	29.76	14.61	44.37	74.00	-29.63	V	peak
12156.000	30.04	15.16	45.20	74.00	-28.80	V	peak
13128.000	28.74	18.29	47.03	74.00	-26.97	V	peak
6768.000	30.64	7.32	37.96	74.00	-36.04	H	Peak
7476.000	30.73	8.63	39.36	74.00	-34.64	H	Peak
9204.000	30.75	9.69	40.44	74.00	-33.56	H	Peak
10368.000	30.42	13.12	43.54	74.00	-30.46	H	peak
10908.000	29.73	14.79	44.52	74.00	-29.48	H	peak
12564.000	30.29	16.51	46.80	74.00	-27.20	H	peak

Remark:

1. Measuring frequencies from 1 GHz to the 10th harmonic of highest fundamental frequency.
2. Radiated emissions measured in frequency above 1000MHz were made with an instrument using peak/average detector mode.
3. Average test would be performed if the peak result were greater than the average limit.
4. Data of measurement within this frequency range shown " --- " in the table above means the reading of emissions are attenuated more than 20dB below the permissible limits or the field strength is too small to be measured.
5. Measurements above show only up to 6 maximum emissions noted, or would be lesser, with " N/A " remark, if no specific emissions from the EUT are recorded (ie: margin>20dB from the applicable limit) and considered that's already beyond the background noise floor.
6. Margin (dB) = Remark result (dBuV/m) – Average limit (dBuV/m).



Test Mode: TX / IEEE 802.11n HT 20 MHz / 5785MHz /(CH Mid) **Tested by:** Jacksan Luo
Ambient temperature: 24°C **Relative humidity:** 52% RH **Date:** November 7, 2016

Frequency (MHz)	Reading (dBuV)	Correction Factor (dB/m)	Result (dBuV/m)	Limit (dBuV/m)	Margin (dB)	Antenna Pole (V/H)	Remark
7668.000	30.95	9.00	39.95	74.00	-34.05	V	peak
9072.000	31.34	9.31	40.65	74.00	-33.35	V	peak
10368.000	30.80	13.12	43.92	74.00	-30.08	V	peak
11136.000	30.43	15.02	45.45	74.00	-28.55	V	peak
12300.000	30.07	15.63	45.70	74.00	-28.30	V	peak
13272.000	28.39	18.67	47.06	74.00	-26.94	V	peak
7080.000	30.78	7.86	38.64	74.00	-35.36	H	Peak
8076.000	30.62	9.61	40.23	74.00	-33.77	H	Peak
9708.000	30.42	11.14	41.56	74.00	-32.44	H	Peak
11136.000	30.19	15.02	45.21	74.00	-28.79	H	peak
12312.000	30.38	15.67	46.05	74.00	-27.95	H	peak
12972.000	29.04	17.86	46.90	74.00	-27.10	H	peak

Remark:

1. Measuring frequencies from 1 GHz to the 10th harmonic of highest fundamental frequency.
2. Radiated emissions measured in frequency above 1000MHz were made with an instrument using peak/average detector mode.
3. Average test would be performed if the peak result were greater than the average limit.
4. Data of measurement within this frequency range shown " --- " in the table above means the reading of emissions are attenuated more than 20dB below the permissible limits or the field strength is too small to be measured.
5. Measurements above show only up to 6 maximum emissions noted, or would be lesser, with " N/A " remark, if no specific emissions from the EUT are recorded (ie: margin>20dB from the applicable limit) and considered that's already beyond the background noise floor.
6. Margin (dB) = Remark result (dBuV/m) – Average limit (dBuV/m).



Test Mode: TX / IEEE 802.11n HT 20 MHz / 5825MHz /(CH High) **Tested by:** Jacksan Luo

Ambient temperature: 24°C **Relative humidity:** 52% RH **Date:** November 7, 2016

Frequency (MHz)	Reading (dBuV)	Correction Factor (dB/m)	Result (dBuV/m)	Limit (dBuV/m)	Margin (dB)	Antenna Pole (V/H)	Remark
7428.000	31.13	8.53	39.66	74.00	-34.34	V	peak
9300.000	30.81	9.96	40.77	74.00	-33.23	V	peak
10344.000	30.69	13.05	43.74	74.00	-30.26	V	peak
11136.000	30.28	15.02	45.30	74.00	-28.70	V	peak
12408.000	30.11	15.99	46.10	74.00	-27.90	V	peak
12960.000	29.25	17.82	47.07	74.00	-26.93	V	peak
7500.000	30.83	8.68	39.51	74.00	-34.49	H	Peak
9108.000	30.86	9.41	40.27	74.00	-33.73	H	Peak
10044.000	30.58	12.12	42.70	74.00	-31.30	H	Peak
11136.000	30.29	15.02	45.31	74.00	-28.69	H	peak
11688.000	30.71	14.78	45.49	74.00	-28.51	H	peak
12984.000	29.68	17.90	47.58	74.00	-26.42	H	peak

Remark:

1. Measuring frequencies from 1 GHz to the 10th harmonic of highest fundamental frequency.
2. Radiated emissions measured in frequency above 1000MHz were made with an instrument using peak/average detector mode.
3. Average test would be performed if the peak result were greater than the average limit.
4. Data of measurement within this frequency range shown " --- " in the table above means the reading of emissions are attenuated more than 20dB below the permissible limits or the field strength is too small to be measured.
5. Measurements above show only up to 6 maximum emissions noted, or would be lesser, with " N/A " remark, if no specific emissions from the EUT are recorded (ie: margin>20dB from the applicable limit) and considered that's already beyond the background noise floor.
6. Margin (dB) = Remark result (dBuV/m) – Average limit (dBuV/m).



Test Mode: TX / IEEE 802.11n HT 40 MHz / 5190MHz / (CH Low) **Tested by:** Jacksan Luo

Ambient temperature: 24°C **Relative humidity:** 52% RH **Date:** November 7, 2016

Frequency (MHz)	Reading (dBuV)	Correction Factor (dB/m)	Result (dBuV/m)	Limit (dBuV/m)	Margin (dB)	Antenna Pole (V/H)	Remark
6864.000	30.79	7.48	38.27	74.00	-35.73	V	peak
8184.000	30.81	9.55	40.36	74.00	-33.64	V	peak
9732.000	30.73	11.21	41.94	74.00	-32.06	V	peak
10632.000	30.26	13.94	44.20	74.00	-29.80	V	peak
11136.000	30.35	15.02	45.37	74.00	-28.63	V	peak
13008.000	28.99	17.97	46.96	74.00	-27.04	V	peak
7500.000	30.92	8.68	39.60	74.00	-34.40	H	Peak
8136.000	31.06	9.58	40.64	74.00	-33.36	H	Peak
9708.000	30.55	11.14	41.69	74.00	-32.31	H	Peak
10308.000	30.29	12.93	43.22	74.00	-30.78	H	peak
11640.000	30.46	14.80	45.26	74.00	-28.74	H	peak
13032.000	29.24	18.03	47.27	74.00	-26.73	H	peak

Remark:

1. Measuring frequencies from 1 GHz to the 10th harmonic of highest fundamental frequency.
2. Radiated emissions measured in frequency above 1000MHz were made with an instrument using peak/average detector mode.
3. Average test would be performed if the peak result were greater than the average limit.
4. Data of measurement within this frequency range shown " --- " in the table above means the reading of emissions are attenuated more than 20dB below the permissible limits or the field strength is too small to be measured.
5. Measurements above show only up to 6 maximum emissions noted, or would be lesser, with " N/A " remark, if no specific emissions from the EUT are recorded (ie: margin>20dB from the applicable limit) and considered that's already beyond the background noise floor.
6. Margin (dB) = Remark result (dBuV/m) – Average limit (dBuV/m).



Test Mode: TX / IEEE 802.11n HT 40 MHz / 5230MHz /(CH High) **Tested by:** Jacksan Luo

Ambient temperature: 24°C **Relative humidity:** 52% RH **Date:** November 7, 2016

Frequency (MHz)	Reading (dBuV)	Correction Factor (dB/m)	Result (dBuV/m)	Limit (dBuV/m)	Margin (dB)	Antenna Pole (V/H)	Remark
7104.000	30.70	7.90	38.60	74.00	-35.40	V	peak
8196.000	30.66	9.54	40.20	74.00	-33.80	V	peak
10008.000	30.60	12.00	42.60	74.00	-31.40	V	peak
10896.000	30.29	14.76	45.05	74.00	-28.95	V	peak
11292.000	30.25	14.95	45.20	74.00	-28.80	V	peak
13260.000	28.88	18.63	47.51	74.00	-26.49	V	peak
7344.000	30.76	8.37	39.13	74.00	-34.87	H	Peak
7824.000	31.18	9.31	40.49	74.00	-33.51	H	Peak
9336.000	30.60	10.07	40.67	74.00	-33.33	H	Peak
9900.000	30.38	11.69	42.07	74.00	-31.93	H	peak
11136.000	30.39	15.02	45.41	74.00	-28.59	H	peak
13044.000	28.92	18.07	46.99	74.00	-27.01	H	peak

Remark:

1. Measuring frequencies from 1 GHz to the 10th harmonic of highest fundamental frequency.
2. Radiated emissions measured in frequency above 1000MHz were made with an instrument using peak/average detector mode.
3. Average test would be performed if the peak result were greater than the average limit.
4. Data of measurement within this frequency range shown " --- " in the table above means the reading of emissions are attenuated more than 20dB below the permissible limits or the field strength is too small to be measured.
5. Measurements above show only up to 6 maximum emissions noted, or would be lesser, with " N/A " remark, if no specific emissions from the EUT are recorded (ie: margin>20dB from the applicable limit) and considered that's already beyond the background noise floor.
6. Margin (dB) = Remark result (dBuV/m) – Average limit (dBuV/m).



Test Mode: TX / IEEE 802.11n HT 40 MHz / 5270MHz / (CH Low) **Tested by:** Jacksan Luo

Ambient temperature: 24°C **Relative humidity:** 52% RH **Date:** November 7, 2016

Frequency (MHz)	Reading (dBuV)	Correction Factor (dB/m)	Result (dBuV/m)	Limit (dBuV/m)	Margin (dB)	Antenna Pole (V/H)	Remark
7512.000	31.07	8.70	39.77	74.00	-34.23	V	peak
8112.000	31.11	9.59	40.70	74.00	-33.30	V	peak
9984.000	30.96	11.93	42.89	74.00	-31.11	V	peak
11280.000	30.16	14.96	45.12	74.00	-28.88	V	peak
11928.000	30.67	14.67	45.34	74.00	-28.66	V	peak
12900.000	29.32	17.62	46.94	74.00	-27.06	V	peak
7704.000	30.91	9.07	39.98	74.00	-34.02	H	Peak
8244.000	31.30	9.52	40.82	74.00	-33.18	H	Peak
9456.000	30.91	10.41	41.32	74.00	-32.68	H	Peak
10860.000	29.80	14.65	44.45	74.00	-29.55	H	peak
12240.000	30.12	15.43	45.55	74.00	-28.45	H	peak
13152.000	29.04	18.35	47.39	74.00	-26.61	H	peak

Remark:

1. Measuring frequencies from 1 GHz to the 10th harmonic of highest fundamental frequency.
2. Radiated emissions measured in frequency above 1000MHz were made with an instrument using peak/average detector mode.
3. Average test would be performed if the peak result were greater than the average limit.
4. Data of measurement within this frequency range shown " --- " in the table above means the reading of emissions are attenuated more than 20dB below the permissible limits or the field strength is too small to be measured.
5. Measurements above show only up to 6 maximum emissions noted, or would be lesser, with " N/A " remark, if no specific emissions from the EUT are recorded (ie: margin>20dB from the applicable limit) and considered that's already beyond the background noise floor.
6. Margin (dB) = Remark result (dBuV/m) – Average limit (dBuV/m).



Test Mode: TX / IEEE 802.11n HT 40 MHz / 5310MHz /(CH High) **Tested by:** Jacksan Luo

Ambient temperature: 24°C **Relative humidity:** 52% RH **Date:** November 7, 2016

Frequency (MHz)	Reading (dBuV)	Correction Factor (dB/m)	Result (dBuV/m)	Limit (dBuV/m)	Margin (dB)	Antenna Pole (V/H)	Remark
7116.000	30.88	7.93	38.81	74.00	-35.19	V	peak
8172.000	30.92	9.56	40.48	74.00	-33.52	V	peak
10116.000	31.23	12.34	43.57	74.00	-30.43	V	peak
10548.000	30.24	13.68	43.92	74.00	-30.08	V	peak
11136.000	30.24	15.02	45.26	74.00	-28.74	V	peak
12624.000	29.87	16.71	46.58	74.00	-27.42	V	peak
6420.000	30.75	6.76	37.51	74.00	-36.49	H	Peak
7512.000	31.24	8.70	39.94	74.00	-34.06	H	Peak
8496.000	31.05	9.38	40.43	74.00	-33.57	H	Peak
10164.000	30.57	12.49	43.06	74.00	-30.94	H	peak
10992.000	29.96	15.06	45.02	74.00	-28.98	H	peak
12516.000	29.96	16.35	46.31	74.00	-27.69	H	peak

Remark:

1. Measuring frequencies from 1 GHz to the 10th harmonic of highest fundamental frequency.
2. Radiated emissions measured in frequency above 1000MHz were made with an instrument using peak/average detector mode.
3. Average test would be performed if the peak result were greater than the average limit.
4. Data of measurement within this frequency range shown " --- " in the table above means the reading of emissions are attenuated more than 20dB below the permissible limits or the field strength is too small to be measured.
5. Measurements above show only up to 6 maximum emissions noted, or would be lesser, with " N/A " remark, if no specific emissions from the EUT are recorded (ie: margin>20dB from the applicable limit) and considered that's already beyond the background noise floor.
6. Margin (dB) = Remark result (dBuV/m) – Average limit (dBuV/m).



Test Mode: TX / IEEE 802.11n HT 40 MHz / 5510MHz / (CH Low) **Tested by:** Jacksan Luo

Ambient temperature: 24°C **Relative humidity:** 52% RH **Date:** November 7, 2016

Frequency (MHz)	Reading (dBuV)	Correction Factor (dB/m)	Result (dBuV/m)	Limit (dBuV/m)	Margin (dB)	Antenna Pole (V/H)	Remark
7368.000	30.55	8.42	38.97	74.00	-35.03	V	peak
8196.000	30.91	9.54	40.45	74.00	-33.55	V	peak
9720.000	30.71	11.17	41.88	74.00	-32.12	V	peak
10380.000	30.56	13.16	43.72	74.00	-30.28	V	peak
11256.000	30.20	14.97	45.17	74.00	-28.83	V	peak
13008.000	29.30	17.97	47.27	74.00	-26.73	V	peak
7188.000	30.80	8.07	38.87	74.00	-35.13	H	Peak
7860.000	31.01	9.38	40.39	74.00	-33.61	H	Peak
9708.000	30.76	11.14	41.90	74.00	-32.10	H	Peak
10584.000	30.84	13.79	44.63	74.00	-29.37	H	peak
11280.000	30.18	14.96	45.14	74.00	-28.86	H	peak
12852.000	29.51	17.46	46.97	74.00	-27.03	H	peak

Remark:

1. Measuring frequencies from 1 GHz to the 10th harmonic of highest fundamental frequency.
2. Radiated emissions measured in frequency above 1000MHz were made with an instrument using peak/average detector mode.
3. Average test would be performed if the peak result were greater than the average limit.
4. Data of measurement within this frequency range shown " --- " in the table above means the reading of emissions are attenuated more than 20dB below the permissible limits or the field strength is too small to be measured.
5. Measurements above show only up to 6 maximum emissions noted, or would be lesser, with " N/A " remark, if no specific emissions from the EUT are recorded (ie: margin>20dB from the applicable limit) and considered that's already beyond the background noise floor.
6. Margin (dB) = Remark result (dBuV/m) – Average limit (dBuV/m).



Test Mode: TX / IEEE 802.11n HT 40 MHz / 5550MHz /(CH Mid) **Tested by:** Jacksan Luo
Ambient temperature: 24°C **Relative humidity:** 52% RH **Date:** November 7, 2016

Frequency (MHz)	Reading (dBuV)	Correction Factor (dB/m)	Result (dBuV/m)	Limit (dBuV/m)	Margin (dB)	Antenna Pole (V/H)	Remark
6708.000	30.62	7.23	37.85	74.00	-36.15	V	peak
7716.000	31.37	9.10	40.47	74.00	-33.53	V	peak
8520.000	30.91	9.36	40.27	74.00	-33.73	V	peak
10020.000	31.14	12.04	43.18	74.00	-30.82	V	peak
11136.000	30.01	15.02	45.03	74.00	-28.97	V	peak
12900.000	29.42	17.62	47.04	74.00	-26.96	V	peak
6984.000	30.98	7.67	38.65	74.00	-35.35	H	Peak
8040.000	30.70	9.63	40.33	74.00	-33.67	H	Peak
9456.000	31.06	10.41	41.47	74.00	-32.53	H	Peak
10644.000	30.10	13.98	44.08	74.00	-29.92	H	peak
11136.000	30.42	15.02	45.44	74.00	-28.56	H	peak
12960.000	29.37	17.82	47.19	74.00	-26.81	H	peak

Remark:

1. Measuring frequencies from 1 GHz to the 10th harmonic of highest fundamental frequency.
2. Radiated emissions measured in frequency above 1000MHz were made with an instrument using peak/average detector mode.
3. Average test would be performed if the peak result were greater than the average limit.
4. Data of measurement within this frequency range shown " --- " in the table above means the reading of emissions are attenuated more than 20dB below the permissible limits or the field strength is too small to be measured.
5. Measurements above show only up to 6 maximum emissions noted, or would be lesser, with " N/A " remark, if no specific emissions from the EUT are recorded (ie: margin>20dB from the applicable limit) and considered that's already beyond the background noise floor.
6. Margin (dB) = Remark result (dBuV/m) – Average limit (dBuV/m).



Test Mode: TX / IEEE 802.11n HT 40 MHz / 5670MHz /(CH High) **Tested by:** Jacksan Luo

Ambient temperature: 24°C **Relative humidity:** 52% RH **Date:** November 7, 2016

Frequency (MHz)	Reading (dBuV)	Correction Factor (dB/m)	Result (dBuV/m)	Limit (dBuV/m)	Margin (dB)	Antenna Pole (V/H)	Remark
7320.000	30.69	8.32	39.01	74.00	-34.99	V	peak
8148.000	30.61	9.57	40.18	74.00	-33.82	V	peak
9144.000	30.82	9.51	40.33	74.00	-33.67	V	peak
9996.000	31.20	11.97	43.17	74.00	-30.83	V	peak
11136.000	30.40	15.02	45.42	74.00	-28.58	V	peak
12900.000	29.47	17.62	47.09	74.00	-26.91	V	peak
7020.000	30.64	7.74	38.38	74.00	-35.62	H	Peak
8088.000	30.67	9.60	40.27	74.00	-33.73	H	Peak
9744.000	31.43	11.24	42.67	74.00	-31.33	H	Peak
11148.000	30.18	15.01	45.19	74.00	-28.81	H	peak
12312.000	30.12	15.67	45.79	74.00	-28.21	H	peak
13056.000	29.51	18.10	47.61	74.00	-26.39	H	peak

Remark:

1. Measuring frequencies from 1 GHz to the 10th harmonic of highest fundamental frequency.
2. Radiated emissions measured in frequency above 1000MHz were made with an instrument using peak/average detector mode.
3. Average test would be performed if the peak result were greater than the average limit.
4. Data of measurement within this frequency range shown " --- " in the table above means the reading of emissions are attenuated more than 20dB below the permissible limits or the field strength is too small to be measured.
5. Measurements above show only up to 6 maximum emissions noted, or would be lesser, with " N/A " remark, if no specific emissions from the EUT are recorded (ie: margin>20dB from the applicable limit) and considered that's already beyond the background noise floor.
6. Margin (dB) = Remark result (dBuV/m) – Average limit (dBuV/m).



Test Mode: TX / IEEE 802.11n HT 40 MHz / 5755MHz /(CH Low) **Tested by:** Jacksan Luo

Ambient temperature: 24°C **Relative humidity:** 52% RH **Date:** November 7, 2016

Frequency (MHz)	Reading (dBuV)	Correction Factor (dB/m)	Result (dBuV/m)	Limit (dBuV/m)	Margin (dB)	Antenna Pole (V/H)	Remark
6984.000	30.55	7.67	38.22	74.00	-35.78	V	peak
7512.000	31.03	8.70	39.73	74.00	-34.27	V	peak
8676.000	30.90	9.28	40.18	74.00	-33.82	V	peak
9924.000	30.70	11.76	42.46	74.00	-31.54	V	peak
11136.000	30.36	15.02	45.38	74.00	-28.62	V	peak
12552.000	30.12	16.47	46.59	74.00	-27.41	V	peak
6708.000	30.84	7.23	38.07	74.00	-35.93	H	Peak
7716.000	31.13	9.10	40.23	74.00	-33.77	H	Peak
9312.000	30.76	10.00	40.76	74.00	-33.24	H	Peak
10356.000	30.10	13.08	43.18	74.00	-30.82	H	peak
11136.000	30.45	15.02	45.47	74.00	-28.53	H	peak
12888.000	29.44	17.58	47.02	74.00	-26.98	H	peak

Remark:

1. Measuring frequencies from 1 GHz to the 10th harmonic of highest fundamental frequency.
2. Radiated emissions measured in frequency above 1000MHz were made with an instrument using peak/average detector mode.
3. Average test would be performed if the peak result were greater than the average limit.
4. Data of measurement within this frequency range shown " --- " in the table above means the reading of emissions are attenuated more than 20dB below the permissible limits or the field strength is too small to be measured.
5. Measurements above show only up to 6 maximum emissions noted, or would be lesser, with " N/A " remark, if no specific emissions from the EUT are recorded (ie: margin>20dB from the applicable limit) and considered that's already beyond the background noise floor.
6. Margin (dB) = Remark result (dBuV/m) – Average limit (dBuV/m).



Test Mode: TX / IEEE 802.11n HT 40 MHz / 5795MHz / (CH High) **Tested by:** Jacksan Luo
Ambient temperature: 24°C **Relative humidity:** 52% RH **Date:** November 7, 2016

Frequency (MHz)	Reading (dBuV)	Correction Factor (dB/m)	Result (dBuV/m)	Limit (dBuV/m)	Margin (dB)	Antenna Pole (V/H)	Remark
7416.000	30.80	8.51	39.31	74.00	-34.69	V	peak
8196.000	30.96	9.54	40.50	74.00	-33.50	V	peak
9096.000	30.96	9.38	40.34	74.00	-33.66	V	peak
10356.000	30.26	13.08	43.34	74.00	-30.66	V	peak
11160.000	30.31	15.01	45.32	74.00	-28.68	V	peak
12948.000	29.54	17.78	47.32	74.00	-26.68	V	peak
8184.000	31.01	9.55	40.56	74.00	-33.44	H	Peak
9048.000	31.23	9.24	40.47	74.00	-33.53	H	Peak
9960.000	30.83	11.86	42.69	74.00	-31.31	H	Peak
10620.000	30.67	13.90	44.57	74.00	-29.43	H	peak
11148.000	30.36	15.01	45.37	74.00	-28.63	H	peak
12936.000	29.05	17.74	46.79	74.00	-27.21	H	peak

Remark:

1. Measuring frequencies from 1 GHz to the 10th harmonic of highest fundamental frequency.
2. Radiated emissions measured in frequency above 1000MHz were made with an instrument using peak/average detector mode.
3. Average test would be performed if the peak result were greater than the average limit.
4. Data of measurement within this frequency range shown " --- " in the table above means the reading of emissions are attenuated more than 20dB below the permissible limits or the field strength is too small to be measured.
5. Measurements above show only up to 6 maximum emissions noted, or would be lesser, with " N/A " remark, if no specific emissions from the EUT are recorded (ie: margin>20dB from the applicable limit) and considered that's already beyond the background noise floor.
6. Margin (dB) = Remark result (dBuV/m) – Average limit (dBuV/m).



6.8 CONDUCTED UNDESIRABLE EMISSION

6.8.1 LIMIT

According to 15.407(b) ,

- (1) For transmitters operating in the 5.15-5.25 GHz band: all emissions outside of the 5.15-5.35 GHz band shall not exceed an EIRP of -27 dBm/MHz.
- (2) All emissions shall be limited to a level of -27 dBm/MHz at 75 MHz or more above or below the band edge increasing linearly to 10 dBm/MHz at 25 MHz above or below the band edge, and from 25 MHz above or below the band edge increasing linearly to a level of 15.6 dBm/MHz at 5 MHz above or below the band edge, and from 5 MHz above or below the band edge increasing linearly to a level of 27 dBm/MHz at the band edge.
- (3) The provisions of §15.205 apply to intentional radiators operating under this section.

6.8.2 MEASUREMENT EQUIPMENT USED

Name of Equipment	Manufacturer	Model	Serial Number	Last Calibration	Due Calibration
Spectrum Analyzer	Agilent	N9010A	MY52221469	02/21/2016	02/20/2017

Remark: Each piece of equipment is scheduled for calibration once a year.

6.8.3 TEST CONFIGURATION

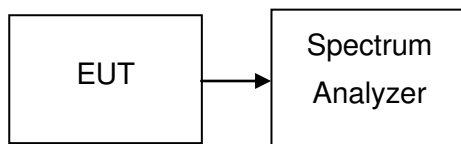

6.8.4 TEST PROCEDURE

Conducted RF measurements of the transmitter output were made to confirm that the EUT antenna port conducted emissions meet the specified limit and to identify any spurious signals that require further investigation or measurements on the radiated emissions site.

The transmitter output is connected to the spectrum analyzer. The resolution bandwidth is set to 1MHz. The video bandwidth is set to 3MHz. Peak detection measurements are compared to the average EIRP limit, adjusted for the maximum antenna gain. If necessary, additional average detection measurements are made.

Measurements are made over the 30 MHz to 40 GHz range with the transmitter set to the lowest, middle, and highest channels.



6.8.5 TEST RESULTS

No non-compliance noted

Test Plot

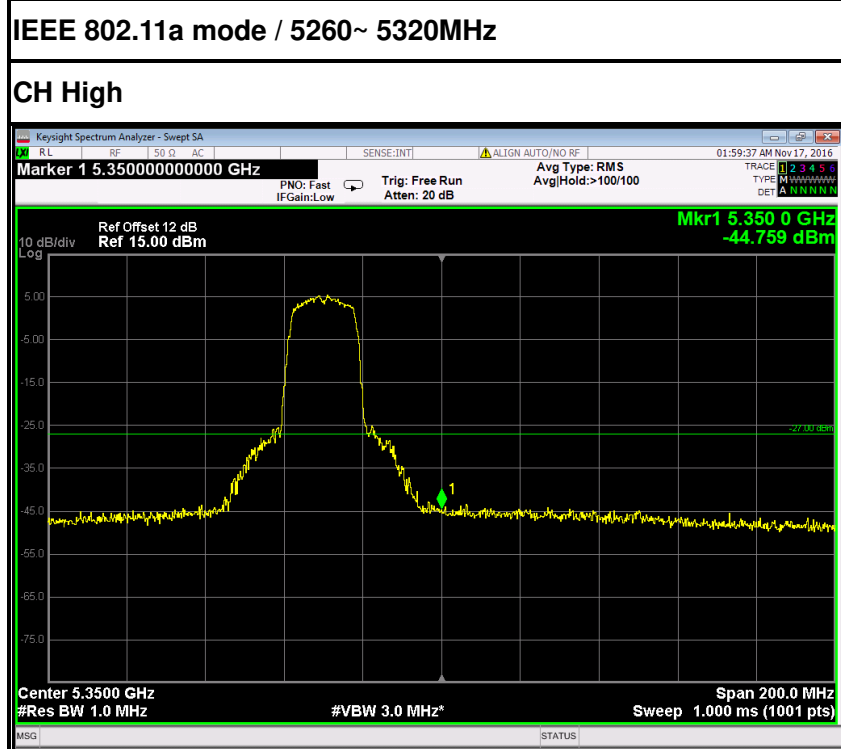
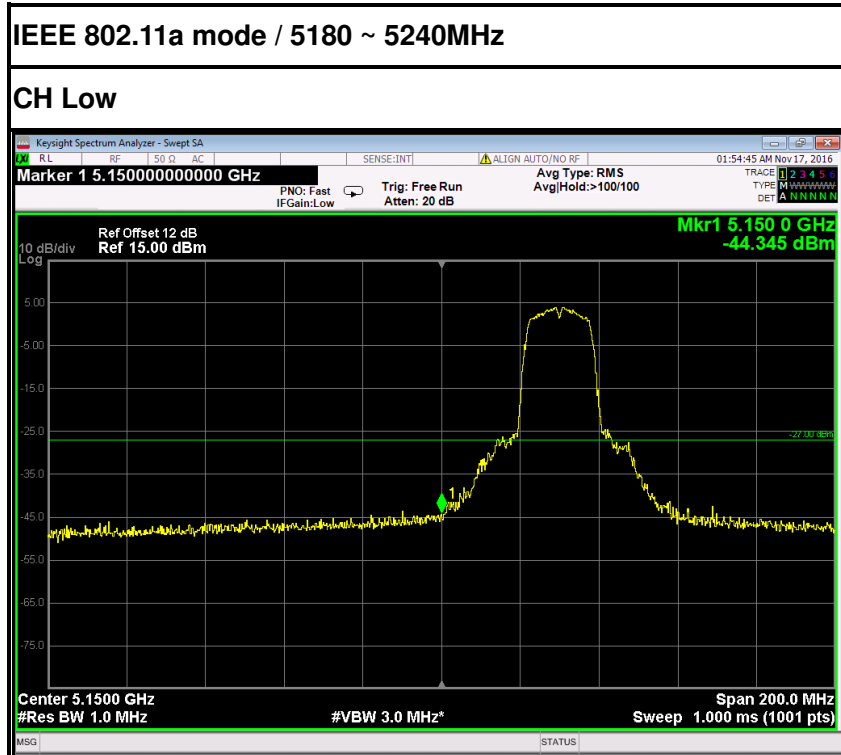

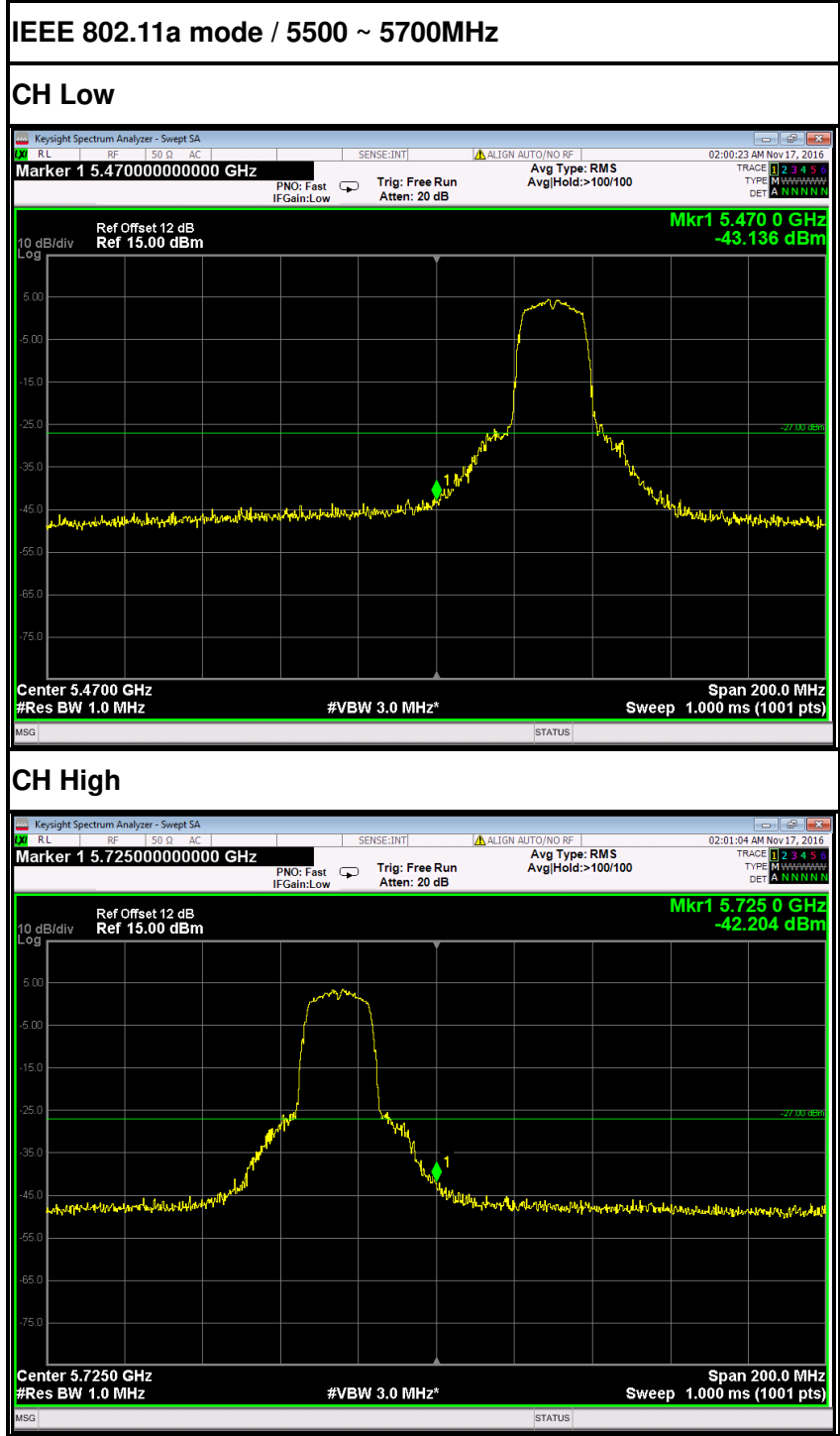

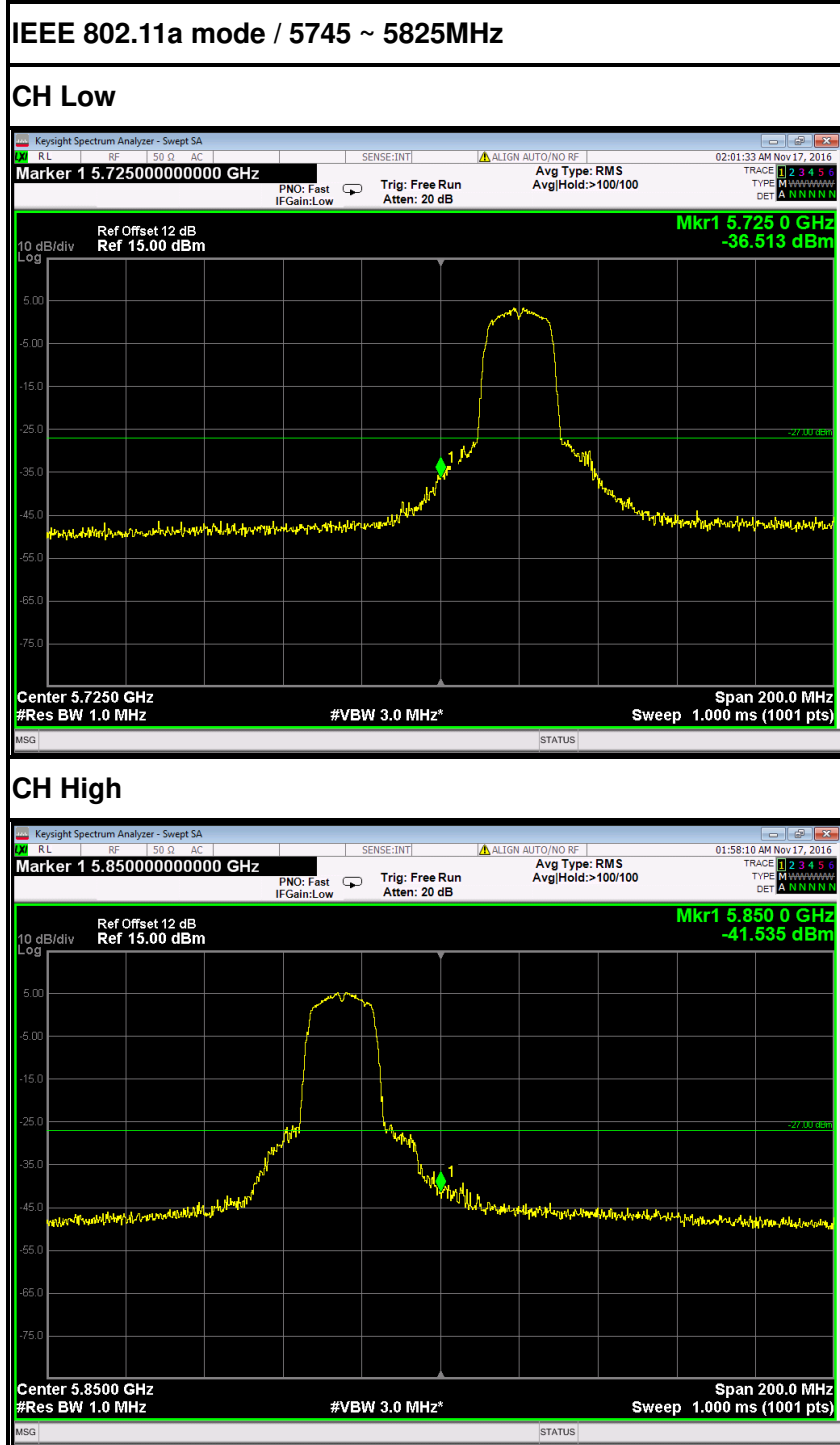

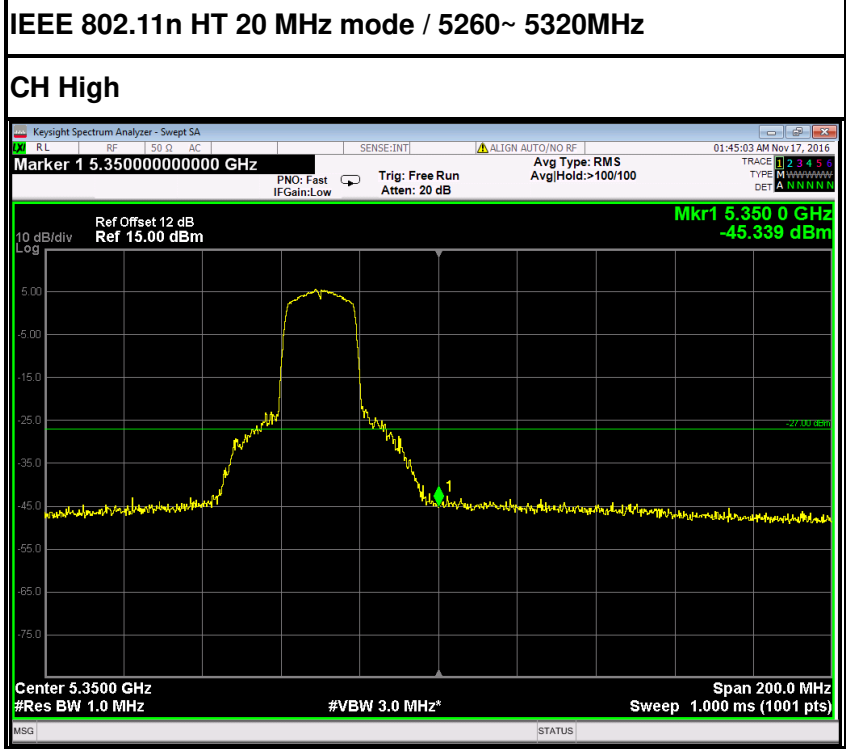
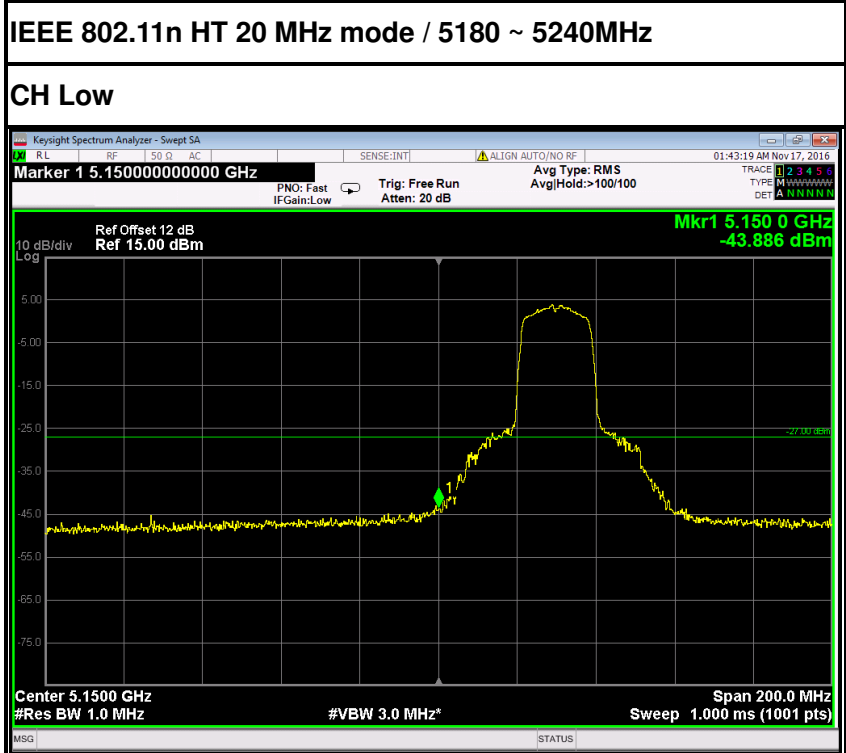

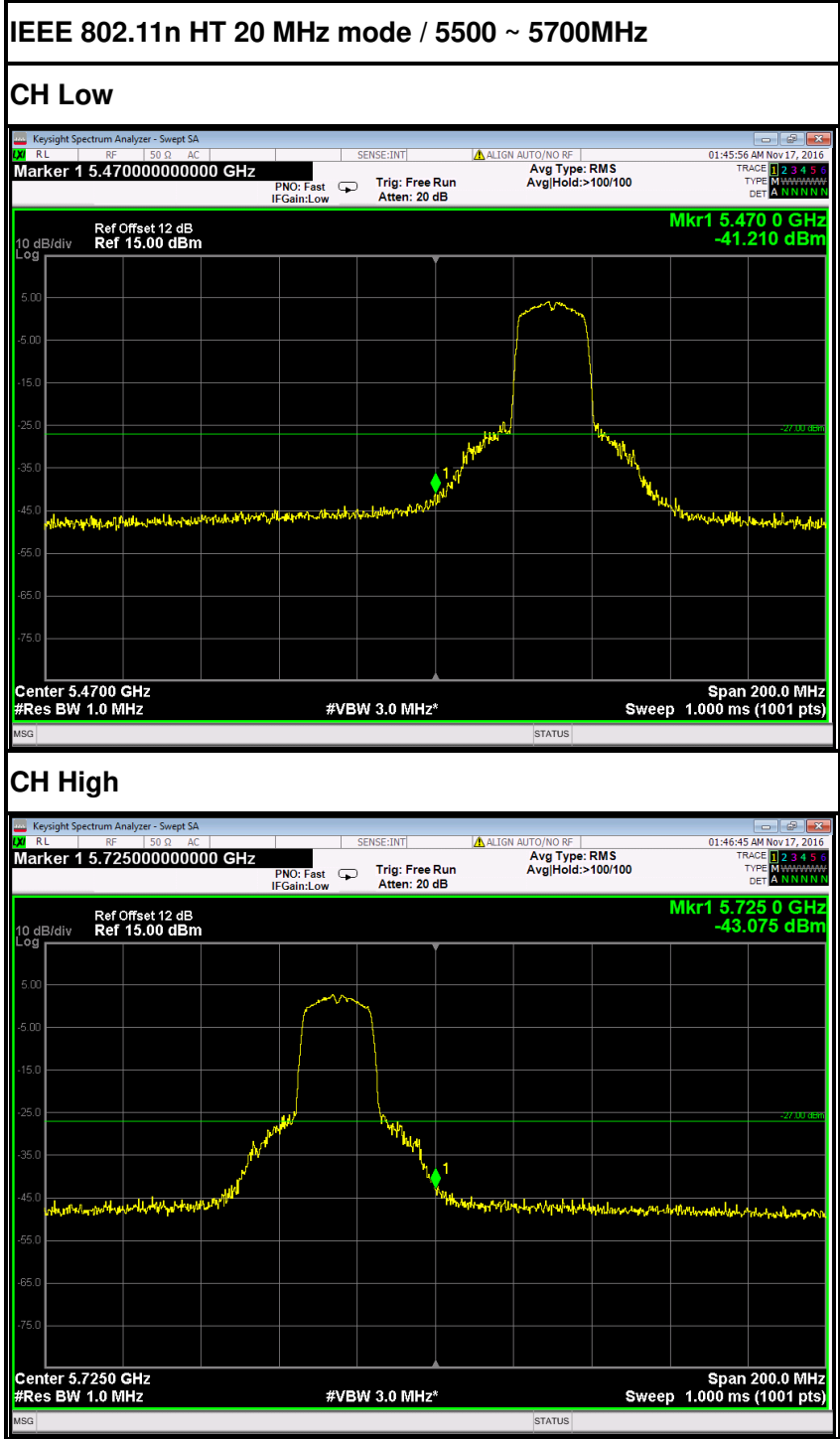

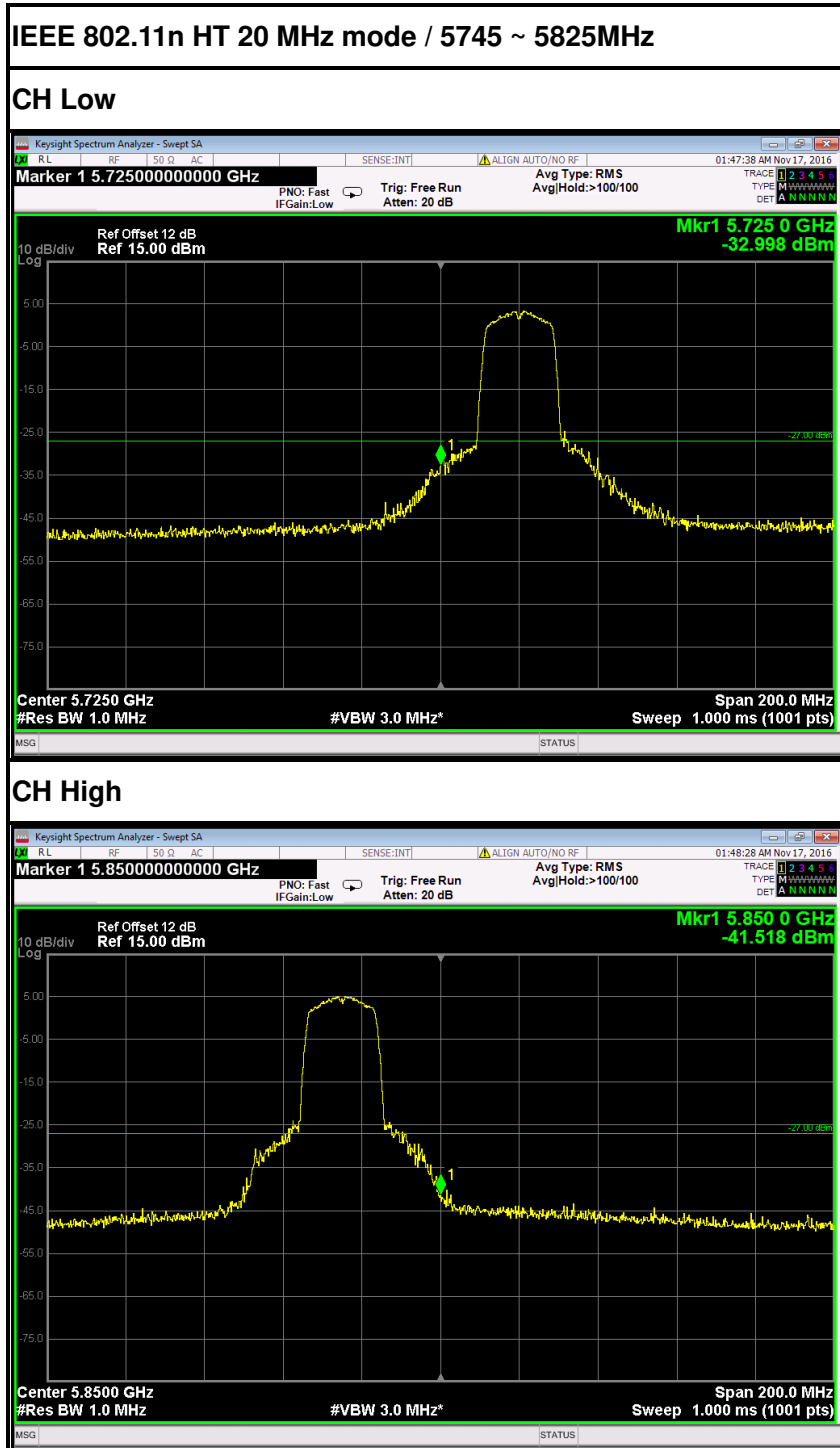

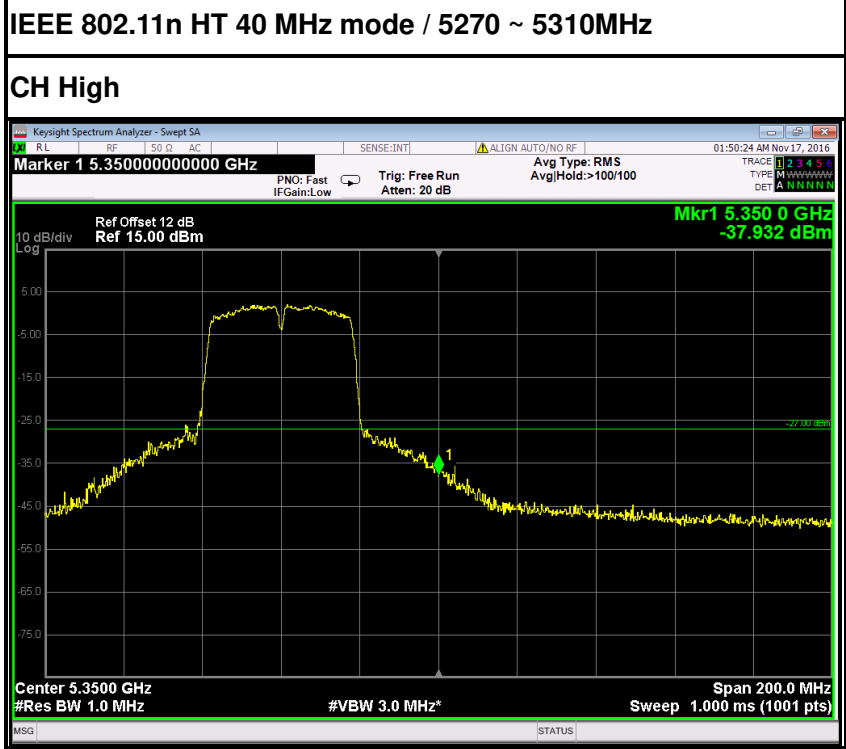
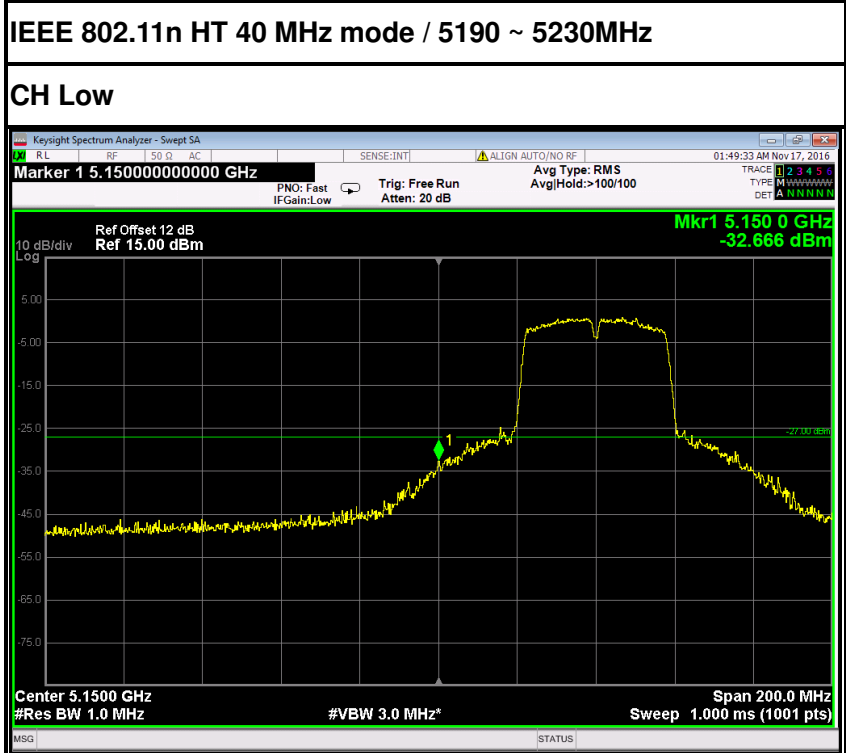

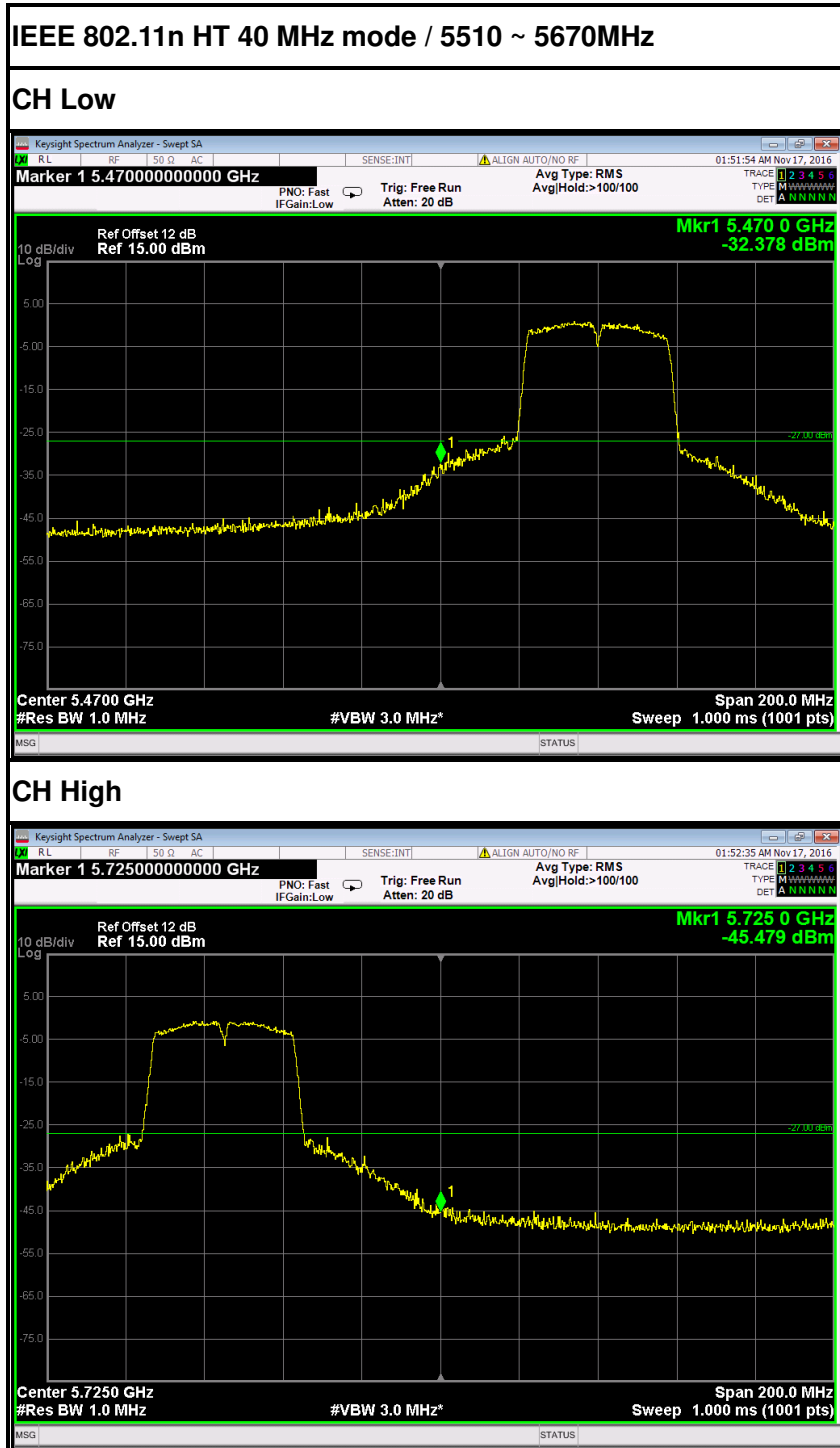

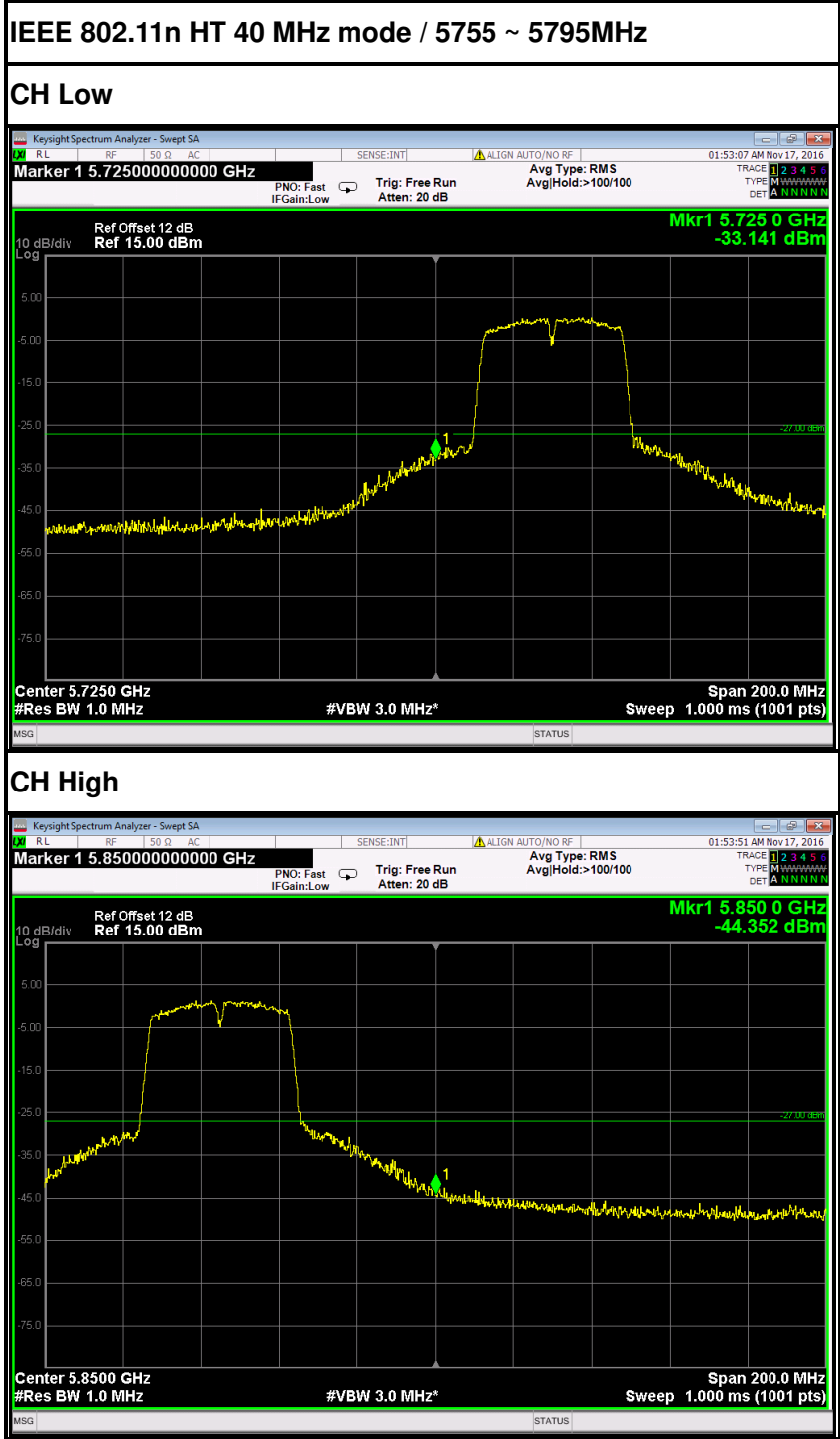



6.9 POWERLINE CONDUCTED EMISSIONS

6.9.1 LIMIT

According to §15.207(a), except as shown in paragraphs (b) and (c) of this section, for an intentional radiator that is designed to be connected to the public utility (AC) power line, the radio frequency voltage that is conducted back onto the AC power line on any frequency or frequencies within the band 150 kHz to 30 MHz shall not exceed the limits in the following table, as measured using a 50 μ H/50 ohms line impedance stabilization network (LISN). Compliance with the provisions of this paragraph shall be based on the measurement of the radio frequency voltage between each power line and ground at the power terminal. The lower limit applies at the boundary between the frequency ranges.

Frequency Range (MHz)	Limits (dB μ V)	
	Quasi-peak	Average
0.15 to 0.50	66 to 56*	56 to 46*
0.50 to 5	56	46
5 to 30	60	50

* Decreases with the logarithm of the frequency.

6.9.2 TEST INSTRUMENTS

Conducted Emission Test Site					
Name of Equipment	Manufacturer	Model Number	Serial Number	Last Calibration	Due Calibration
EMI TEST RECEIVER	ROHDE&SCHWARZ	ESCI	100783	02/21/2016	02/20/2017
LISN(EUT)	ROHDE&SCHWARZ	ENV216	101543-WX	02/21/2016	02/20/2017
LISN	EMCO	3825/2	8901-1459	02/21/2016	02/20/2017
Temp. / Humidity Meter	VICTOR	HTC-1	N/A	02/21/2016	02/20/2017
Test S/W	FARAD	EZ-EMC/ CCS-3A1-CE			

- NOTE:** 1. The calibration interval of the above test instruments is 12 months and the calibrations are traceable to NML/ROC and NIST/USA.
2. N.C.R = No Calibration Request.



6.9.3 TEST CONFIGURATION

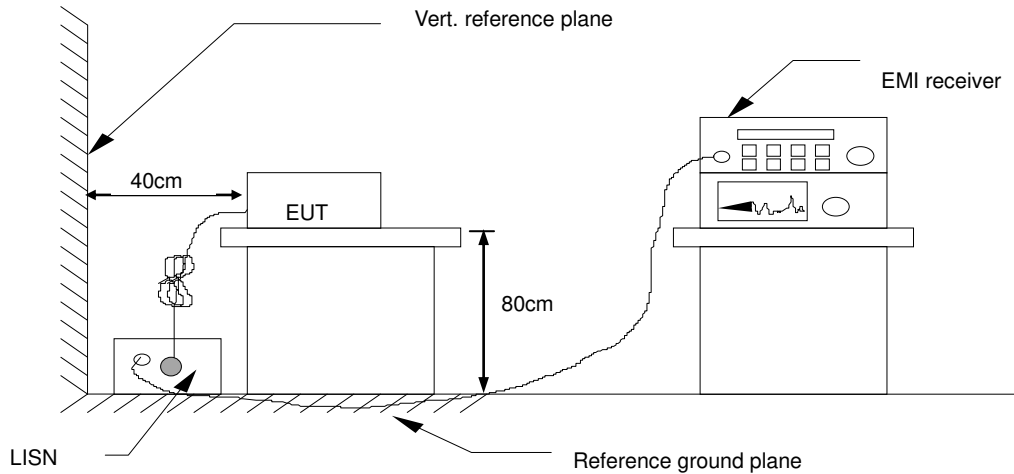

6.9.4 TEST PROCEDURE

1. The EUT was placed on a table, which is 0.8m above ground plane.
2. Maximum procedure was performed on the six highest emissions to ensure EUT compliance.
3. Repeat above procedures until all frequency measured were complete.

6.9.5 DATA SAMPLE

Frequency (MHz)	QuasiPeak Reading (dBuV)	Average Reading (dBuV)	Correction Factor (dB)	QuasiPeak Result (dBuV)	Average Result (dBuV)	QuasiPeak Limit (dBuV)	Average Limit (dBuV)	QuasiPeak Margin (dB)	Average Margin (dB)	Remark (Pass/Fail)
X.XXXX	32.69	25.65	11.52	44.21	37.17	65.78	55.79	-21.57	-18.62	Pass

Factor = Insertion loss of LISN + Cable Loss
Result = Quasi-peak Reading/ Average Reading + Factor
Limit = Limit stated in standard
Margin = Result (dBuV) – Limit (dBuV)



6.9.6 TEST RESULTS

Model No.	NTMC17	RBW,VBW	9 kHz
Environmental Conditions	22°C, 45% RH	Test Mode	Mode 1
Tested by	Jacksan Luo	Line	L1
Test Date	November 7, 2016		

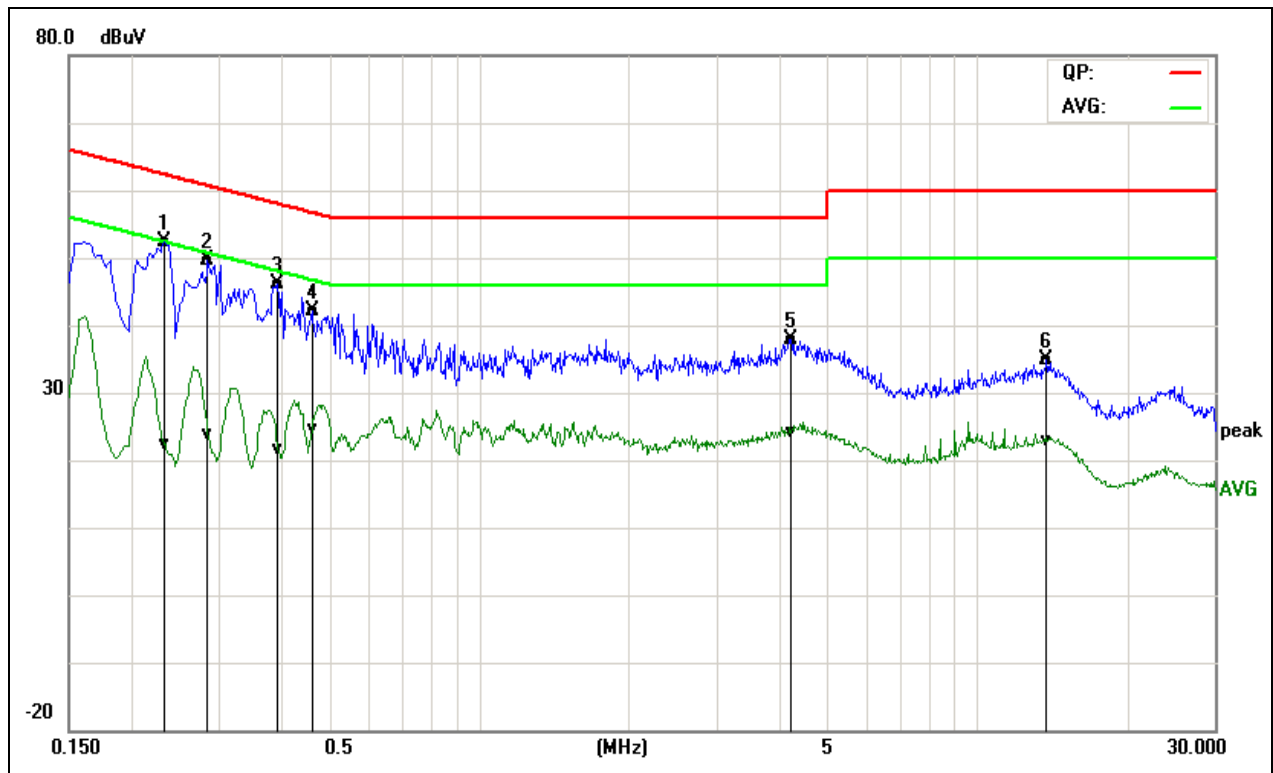

Frequency (MHz)	QuasiPeak Reading (dBuV)	Average Reading (dBuV)	Correction Factor (dB)	QuasiPeak Result (dBuV)	Average Result (dBuV)	QuasiPeak Limit (dBuV)	Average Limit (dBuV)	QuasiPeak Margin (dB)	Average Margin (dB)	Remark (Pass/Fail)
0.2340	32.63	2.78	19.64	52.27	22.42	62.30	52.31	-10.03	-29.89	Pass
0.2860	29.91	4.19	19.64	49.55	23.83	60.64	50.64	-11.09	-26.81	Pass
0.3940	26.60	2.06	19.63	46.23	21.69	57.98	47.98	-11.75	-26.29	Pass
0.4620	22.47	4.90	19.63	42.10	24.53	56.66	46.66	-14.56	-22.13	Pass
4.2460	18.30	4.48	19.66	37.96	24.14	56.00	46.00	-18.04	-21.86	Pass
13.7820	14.80	2.82	19.97	34.77	22.79	60.00	50.00	-25.23	-27.21	Pass

REMARKS: L1 = Line One (Live Line)



Model No.	NTMC17	RBW,VBW	9 kHz
Environmental Conditions	22°C, 45% RH	Test Mode	Mode 1
Tested by	Jackson Luo	Line	L2
Test Date	November 7, 2016		

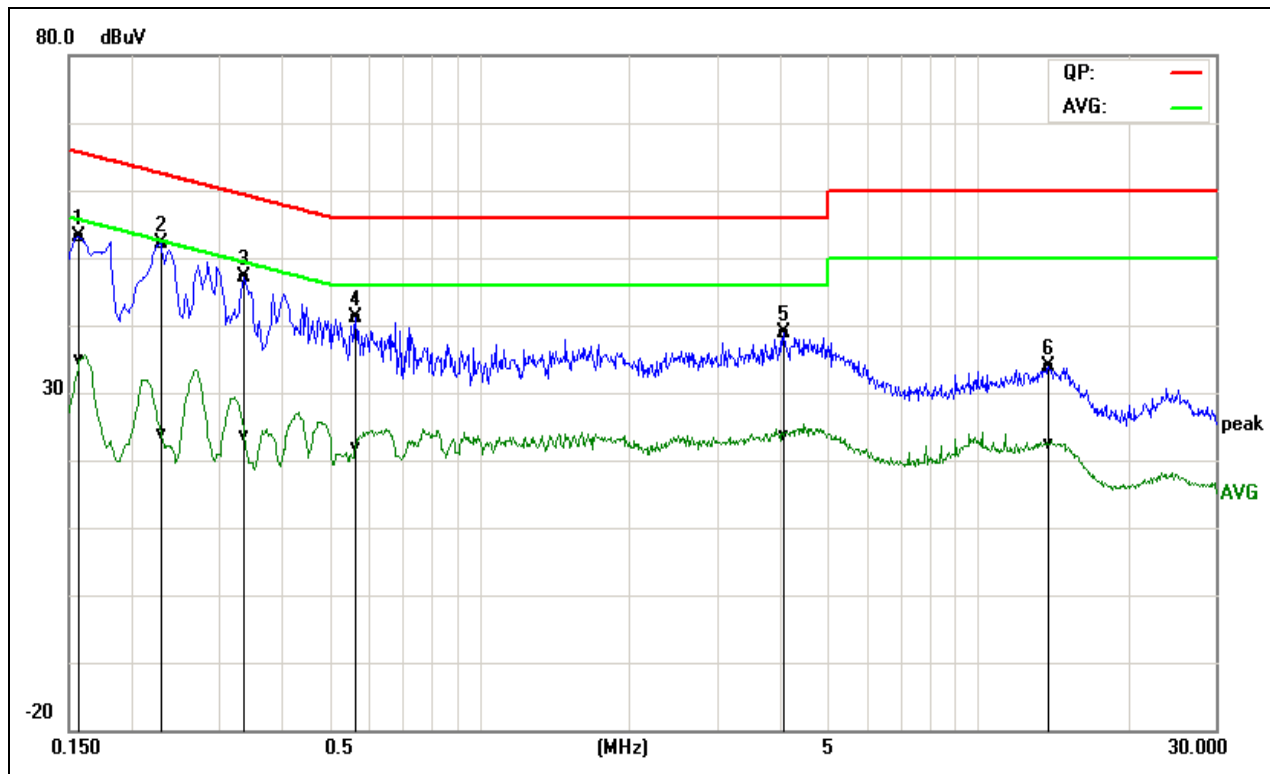

Frequency (MHz)	QuasiPeak Reading (dBuV)	Average Reading (dBuV)	Correction Factor (dB)	QuasiPeak Result (dBuV)	Average Result (dBuV)	QuasiPeak Limit (dBuV)	Average Limit (dBuV)	QuasiPeak Margin (dB)	Average Margin (dB)	Remark (Pass/Fail)
0.1580	33.32	15.24	19.72	53.04	34.96	65.56	55.57	-12.52	-20.61	Pass
0.2300	32.43	4.20	19.73	52.16	23.93	62.45	52.45	-10.29	-28.52	Pass
0.3379	27.42	3.91	19.69	47.11	23.60	59.25	49.25	-12.14	-25.65	Pass
0.5660	21.41	2.34	19.66	41.07	22.00	56.00	46.00	-14.93	-24.00	Pass
4.0820	19.14	3.93	19.73	38.87	23.66	56.00	46.00	-17.13	-22.34	Pass
13.8900	14.16	2.61	19.80	33.96	22.41	60.00	50.00	-26.04	-27.59	Pass

REMARKS: L2 = Line Two (Neutral Line)



Model No.	NTMC17	RBW,VBW	9 kHz
Environmental Conditions	22°C, 45% RH	Test Mode	Mode 3
Tested by	Jacksan Luo	Line	L1
Test Date	November 7, 2016		

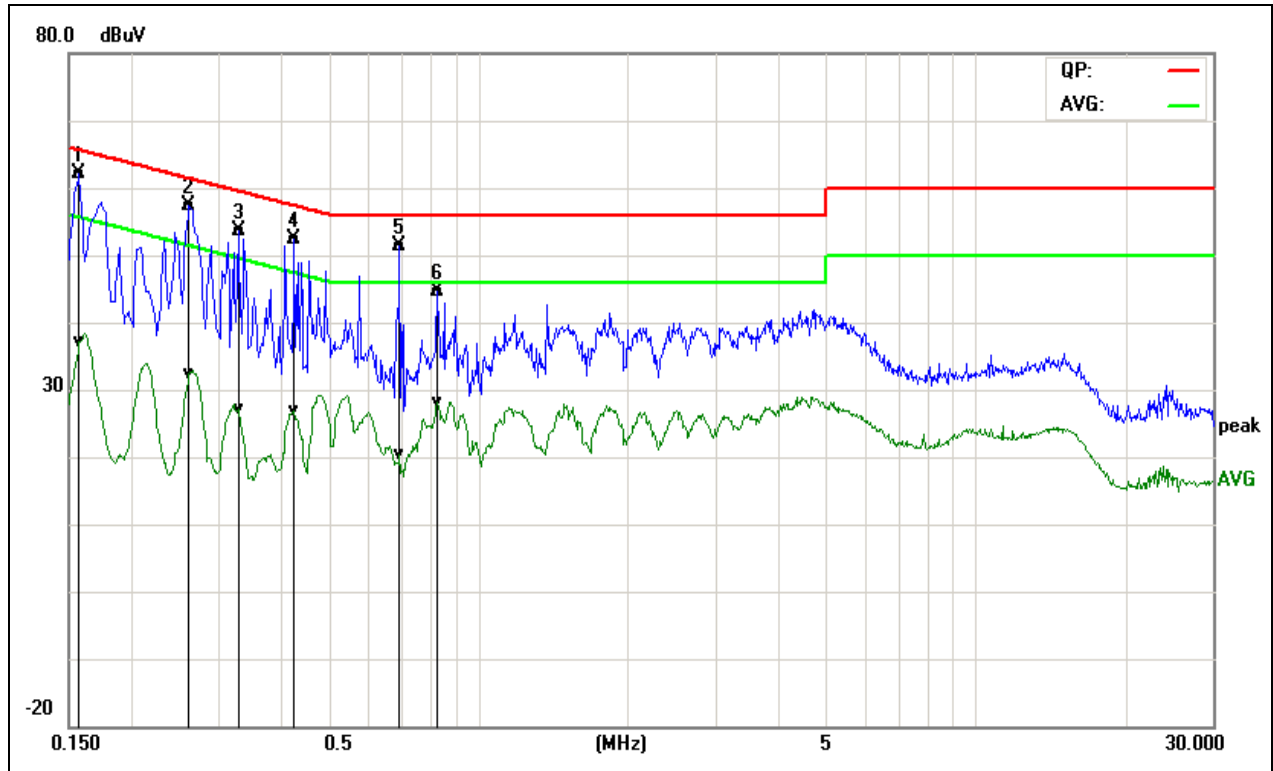

Frequency (MHz)	QuasiPeak Reading (dBuV)	Average Reading (dBuV)	Correction Factor (dB)	QuasiPeak Result (dBuV)	Average Result (dBuV)	QuasiPeak Limit (dBuV)	Average Limit (dBuV)	QuasiPeak Margin (dB)	Average Margin (dB)	Remark (Pass/Fail)
0.1580	42.48	17.57	19.54	62.02	37.11	65.56	55.57	-3.54	-18.46	Pass
0.2620	37.75	12.75	19.64	57.39	32.39	61.36	51.37	-3.97	-18.98	Pass
0.3300	34.04	7.46	19.64	53.68	27.10	59.45	49.45	-5.77	-22.35	Pass
0.4260	32.74	7.17	19.63	52.37	26.80	57.33	47.33	-4.96	-20.53	Pass
0.6940	31.55	0.49	19.81	51.36	20.30	56.00	46.00	-4.64	-25.70	Pass
0.8300	25.00	8.35	19.74	44.74	28.09	56.00	46.00	-11.26	-17.91	Pass

REMARKS: L1 = Line One (Live Line)



Model No.	NTMC17	RBW,VBW	9 kHz
Environmental Conditions	22°C, 45% RH	Test Mode	Mode 3
Tested by	Jackson Luo	Line	L2
Test Date	November 7, 2016		

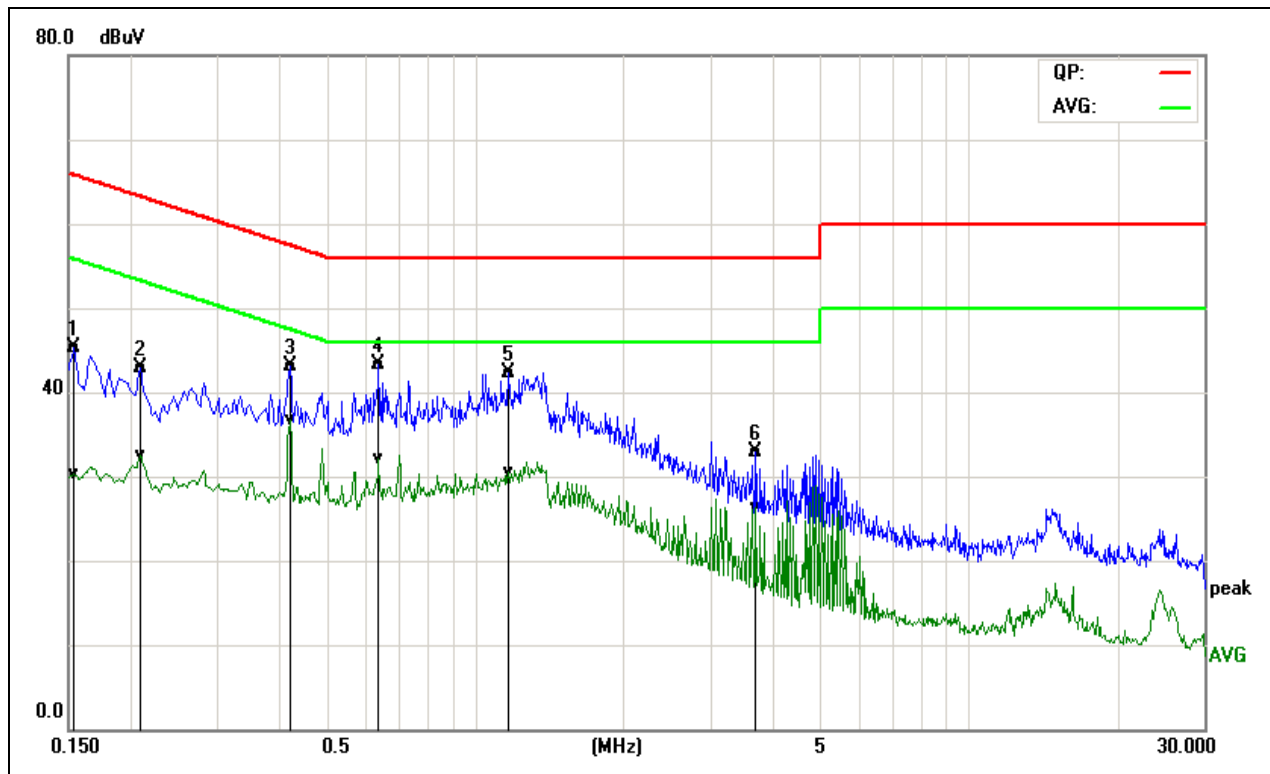

Frequency (MHz)	QuasiPeak Reading (dBuV)	Average Reading (dBuV)	Correction Factor (dB)	QuasiPeak Result (dBuV)	Average Result (dBuV)	QuasiPeak Limit (dBuV)	Average Limit (dBuV)	QuasiPeak Margin (dB)	Average Margin (dB)	Remark (Pass/Fail)
0.1539	25.57	10.59	19.72	45.29	30.31	65.78	55.79	-20.49	-25.48	Pass
0.2094	23.13	12.74	19.74	42.87	32.48	63.23	53.23	-20.36	-20.75	Pass
0.4214	23.54	16.98	19.66	43.20	36.64	57.42	47.42	-14.22	-10.78	Pass
0.6371	23.58	12.48	19.68	43.26	32.16	56.00	46.00	-12.74	-13.84	Pass
1.1656	22.57	10.81	19.74	42.31	30.55	56.00	46.00	-13.69	-15.45	Pass
3.7000	13.23	6.62	19.73	32.96	26.35	56.00	46.00	-23.04	-19.65	Pass

REMARKS: L2 = Line Two (Neutral Line)



6.10 FREQUENCY STABILITY

6.10.1 LIMIT

According to §15.407(g), manufacturers of U-NII devices are responsible for ensuring frequency stability such that an emission is maintained within the band of operation under all conditions of normal operation as specified in the operational description.

6.10.2 TEST INSTRUMENTS

Name of Equipment	Manufacturer	Model Number	Serial Number	Last Calibration	Due Calibration
Spectrum Analyzer	Agilent	N9010A	MY52221469	02/21/2016	02/20/2017
DC Power Supply	DAZHENG	PS-605D	20018978	N.C.R	N.C.R
AC POWER SOUCE	UMART	HPA1010	N/A	N.C.R	N.C.R
Power Meter	Anritsu	ML2495A	1204003	02/21/2016	02/20/2017
Power Sensor	Anritsu	MA2411B	1126150	02/21/2016	02/20/2017
Temperature Chamber	TERCHY	MHG-800N	E21104	11/18/2016	11/17/2017
Temp. / Humidity Meter	Anymetre	JR913	N/A	02/21/2016	02/20/2017

6.10.3 TEST CONFIGURATION

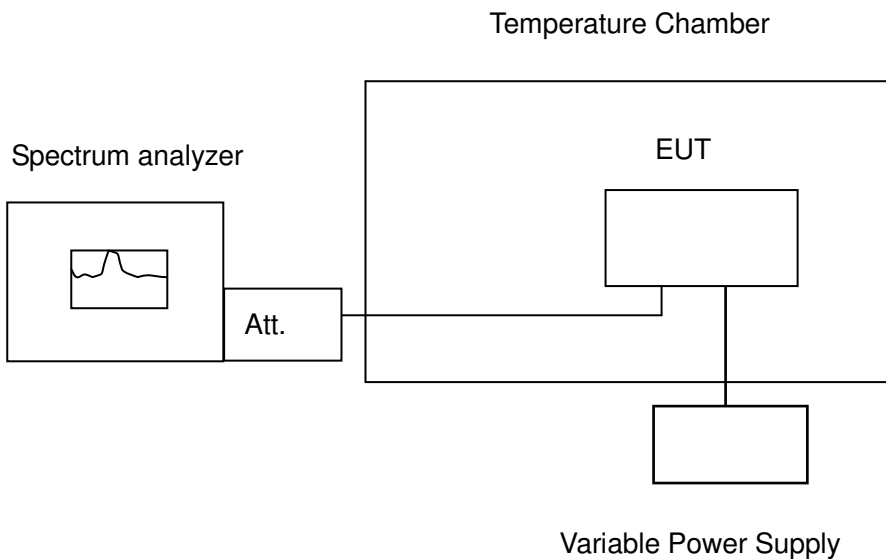

Remark: Measurement setup for testing on Antenna connector



6.10.4 TEST PROCEDURE

The equipment under test was connected to an external AC or DC power supply and input rated voltage. RF output was connected to a frequency counter or spectrum analyzer via feed through attenuators. The EUT was placed inside the temperature chamber. Set the spectrum analyzer RBW low enough to obtain the desired frequency resolution and measure EUT 20°C operating frequency as reference frequency. Turn EUT off and set the chamber temperature to -20°C. After the temperature stabilized for approximately 30 minutes recorded the frequency. Repeat step measure with 10°C increased per stage until the highest temperature of +50°C reached.

6.10.5 TEST RESULTS

No non-compliance noted.



Test Data

IEEE 802.11a MHz mode / 5180 ~ 5240MHz (Low)

Environment Temperature (°C)	Volage (V)	Measured Frequency (MHz)	limit Range	Test Result
50	120	5179.978803	5150-5250	PASS
40	120	5179.985817	5150-5250	PASS
30	120	5179.951770	5150-5250	PASS
20	120	5179.988790	5150-5250	PASS
10	120	5179.975642	5150-5250	PASS
0	120	5179.957476	5150-5250	PASS
-10	120	5179.952240	5150-5250	PASS
-20	120	5179.973852	5150-5250	PASS

Environment Temperature (°C)	Volage (V)	Measured Frequency (MHz)	limit Range	Test Result
20	108	5179.983156	5150-5250	PASS
	120	5179.988790	5150-5250	PASS
	132	5179.992523	5150-5250	PASS

IEEE 802.11a MHz mode / 5180 ~ 5240MHz (High)

Environment Temperature (°C)	Volage (V)	Measured Frequency (MHz)	limit Range	Test Result
50	120	5239.989590	5150-5250	PASS
40	120	5239.967876	5150-5250	PASS
30	120	5239.984632	5150-5250	PASS
20	120	5239.976891	5150-5250	PASS
10	120	5239.984807	5150-5250	PASS
0	120	5239.966057	5150-5250	PASS
-10	120	5239.966859	5150-5250	PASS
-20	120	5239.967145	5150-5250	PASS

Environment Temperature (°C)	Volage (V)	Measured Frequency (MHz)	limit Range	Test Result
20	108	5239.963500	5150-5250	PASS
	120	5239.976891	5150-5250	PASS
	132	5239.995135	5150-5250	PASS



IEEE 802.11a mode / 5260 ~ 5320MHz (Low)

Environment Temperature (°C)	Volage (V)	Measured Frequency (MHz)	limit Range	Test Result
50	120	5259.992292	5250-5350	PASS
40	120	5259.999740	5250-5350	PASS
30	120	5259.989952	5250-5350	PASS
20	120	5260.978690	5250-5350	PASS
10	120	5259.987488	5250-5350	PASS
0	120	5259.965817	5250-5350	PASS
-10	120	5259.986325	5250-5350	PASS
-20	120	5259.980289	5250-5350	PASS

Environment Temperature (°C)	Volage (V)	Measured Frequency (MHz)	limit Range	Test Result
20	108	5259.975846	5250-5350	PASS
	120	5260.978690	5250-5350	PASS
	132	5259.976428	5250-5350	PASS

IEEE 802.11a mode / 5260 ~ 5320MHz (High)

Environment Temperature (°C)	Volage (V)	Measured Frequency (MHz)	limit Range	Test Result
50	120	5319.992743	5250-5350	PASS
40	120	5319.950972	5250-5350	PASS
30	120	5319.951980	5250-5350	PASS
20	120	5320.075684	5250-5350	PASS
10	120	5319.965833	5250-5350	PASS
0	120	5319.970121	5250-5350	PASS
-10	120	5319.960443	5250-5350	PASS
-20	120	5319.970132	5250-5350	PASS

Environment Temperature (°C)	Volage (V)	Measured Frequency (MHz)	limit Range	Test Result
20	108	5319.961718	5250-5350	PASS
	120	5320.075684	5250-5350	PASS
	132	5319.971326	5250-5350	PASS



IEEE 802.11a mode / 5500 ~ 5700MHz (Low)

Environment Temperature (°C)	Volage (V)	Measured Frequency (MHz)	limit Range	Test Result
50	120	5499.964558	5475-5725	PASS
40	120	5499.999849	5475-5725	PASS
30	120	5499.988254	5475-5725	PASS
20	120	5499.987872	5475-5725	PASS
10	120	5499.985019	5475-5725	PASS
0	120	5499.990834	5475-5725	PASS
-10	120	5499.988810	5475-5725	PASS
-20	120	5499.998789	5475-5725	PASS

Environment Temperature (°C)	Volage (V)	Measured Frequency (MHz)	limit Range	Test Result
20	108	5499.949473	5475-5725	PASS
	120	5499.987872	5475-5725	PASS
	132	5499.978563	5475-5725	PASS

IEEE 802.11a mode / 5500 ~ 5700MHz (High)

Environment Temperature (°C)	Volage (V)	Measured Frequency (MHz)	limit Range	Test Result
50	120	5699.985092	5475-5725	PASS
40	120	5699.971973	5475-5725	PASS
30	120	5699.962593	5475-5725	PASS
20	120	5699.968754	5475-5725	PASS
10	120	5699.993436	5475-5725	PASS
0	120	5699.988033	5475-5725	PASS
-10	120	5699.968966	5475-5725	PASS
-20	120	5699.979333	5475-5725	PASS

Environment Temperature (°C)	Volage (V)	Measured Frequency (MHz)	limit Range	Test Result
20	108	5699.959924	5475-5725	PASS
	120	5699.968754	5475-5725	PASS
	132	5699.999667	5475-5725	PASS



IEEE 802.11a mode / 5745 ~ 5825MHz (Low)

Environment Temperature (°C)	Volage (V)	Measured Frequency (MHz)	limit Range	Test Result
50	120	5744.966849	5725-5850	PASS
40	120	5744.961866	5725-5850	PASS
30	120	5744.955797	5725-5850	PASS
20	120	5744.976584	5725-5850	PASS
10	120	5744.964155	5725-5850	PASS
0	120	5744.999845	5725-5850	PASS
-10	120	5744.953506	5725-5850	PASS
-20	120	5744.983122	5725-5850	PASS

Environment Temperature (°C)	Volage (V)	Measured Frequency (MHz)	limit Range	Test Result
20	108	5744.978069	5725-5850	PASS
	120	5744.976584	5725-5850	PASS
	132	5744.997731	5725-5850	PASS

IEEE 802.11a mode / 5745 ~ 5825MHz (High)

Environment Temperature (°C)	Volage (V)	Measured Frequency (MHz)	limit Range	Test Result
50	120	5824.996990	5725-5850	PASS
40	120	5824.985460	5725-5850	PASS
30	120	5824.993540	5725-5850	PASS
20	120	5824.897674	5725-5850	PASS
10	120	5824.999846	5725-5850	PASS
0	120	5824.976711	5725-5850	PASS
-10	120	5824.974298	5725-5850	PASS
-20	120	5824.961965	5725-5850	PASS

Environment Temperature (°C)	Volage (V)	Measured Frequency (MHz)	limit Range	Test Result
20	108	5824.967606	5725-5850	PASS
	120	5824.897674	5725-5850	PASS
	132	5824.985730	5725-5850	PASS



IEEE 802.11n HT 20 MHz mode / 5180 ~ 5240MHz (Low)

Environment Temperature (°C)	Volage (V)	Measured Frequency (MHz)	limit Range	Test Result
50	120	5179.994935	5150-5250	PASS
40	120	5179.955484	5150-5250	PASS
30	120	5179.953046	5150-5250	PASS
20	120	5179.896357	5150-5250	PASS
10	120	5179.977052	5150-5250	PASS
0	120	5179.969668	5150-5250	PASS
-10	120	5179.958530	5150-5250	PASS
-20	120	5179.973218	5150-5250	PASS

Environment Temperature (°C)	Volage (V)	Measured Frequency (MHz)	limit Range	Test Result
20	108	5179.967752	5150-5250	PASS
	120	5179.896357	5150-5250	PASS
	132	5179.970927	5150-5250	PASS

IEEE 802.11n HT 20 MHz mode / 5180 ~ 5240MHz (High)

Environment Temperature (°C)	Volage (V)	Measured Frequency (MHz)	limit Range	Test Result
50	120	5239.994888	5150-5250	PASS
40	120	5239.971744	5150-5250	PASS
30	120	5239.972136	5150-5250	PASS
20	120	5239.896458	5150-5250	PASS
10	120	5239.989396	5150-5250	PASS
0	120	5239.956658	5150-5250	PASS
-10	120	5239.991770	5150-5250	PASS
-20	120	5239.991678	5150-5250	PASS

Environment Temperature (°C)	Volage (V)	Measured Frequency (MHz)	limit Range	Test Result
20	108	5239.962134	5150-5250	PASS
	120	5239.896458	5150-5250	PASS
	132	5239.997686	5150-5250	PASS



IEEE 802.11n HT 20 MHz mode / 5260 ~ 5320MHz (Low)

Environment Temperature (°C)	Volage (V)	Measured Frequency (MHz)	limit Range	Test Result
50	120	5259.973916	5250-5350	PASS
40	120	5259.953660	5250-5350	PASS
30	120	5259.998867	5250-5350	PASS
20	120	5259.945897	5250-5350	PASS
10	120	5259.997725	5250-5350	PASS
0	120	5259.966105	5250-5350	PASS
-10	120	5259.951254	5250-5350	PASS
-20	120	5259.961879	5250-5350	PASS

Environment Temperature (°C)	Volage (V)	Measured Frequency (MHz)	limit Range	Test Result
20	108	5259.961821	5250-5350	PASS
	120	5259.945897	5250-5350	PASS
	132	5259.988173	5250-5350	PASS

IEEE 802.11n HT 20 MHz mode / 5260 ~ 5320MHz (High)

Environment Temperature (°C)	Volage (V)	Measured Frequency (MHz)	limit Range	Test Result
50	120	5319.970467	5250-5350	PASS
40	120	5319.952543	5250-5350	PASS
30	120	5319.978874	5250-5350	PASS
20	120	5319.979657	5250-5350	PASS
10	120	5319.992848	5250-5350	PASS
0	120	5319.967099	5250-5350	PASS
-10	120	5319.987444	5250-5350	PASS
-20	120	5319.968573	5250-5350	PASS

Environment Temperature (°C)	Volage (V)	Measured Frequency (MHz)	limit Range	Test Result
20	108	5319.989268	5250-5350	PASS
	120	5319.979657	5250-5350	PASS
	132	5319.976152	5250-5350	PASS



IEEE 802.11n HT 20 MHz mode / 5500 ~ 5700MHz (Low)

Environment Temperature (°C)	Volage (V)	Measured Frequency (MHz)	limit Range	Test Result
50	120	5499.965801	5475-5725	PASS
40	120	5499.966342	5475-5725	PASS
30	120	5499.978856	5475-5725	PASS
20	120	5499.968724	5475-5725	PASS
10	120	5499.997528	5475-5725	PASS
0	120	5499.961481	5475-5725	PASS
-10	120	5499.999074	5475-5725	PASS
-20	120	5499.952131	5475-5725	PASS

Environment Temperature (°C)	Volage (V)	Measured Frequency (MHz)	limit Range	Test Result
20	108	5499.974810	5475-5725	PASS
	120	5499.968724	5475-5725	PASS
	132	5499.967905	5475-5725	PASS

IEEE 802.11n HT 20 MHz mode / 5500 ~ 5700MHz (High)

Environment Temperature (°C)	Volage (V)	Measured Frequency (MHz)	limit Range	Test Result
50	120	5699.981033	5475-5725	PASS
40	120	5699.969260	5475-5725	PASS
30	120	5699.949785	5475-5725	PASS
20	120	5699.983278	5475-5725	PASS
10	120	5699.979458	5475-5725	PASS
0	120	5699.965682	5475-5725	PASS
-10	120	5699.983949	5475-5725	PASS
-20	120	5699.963988	5475-5725	PASS

Environment Temperature (°C)	Volage (V)	Measured Frequency (MHz)	limit Range	Test Result
20	108	5699.952111	5475-5725	PASS
	120	5699.983278	5475-5725	PASS
	132	5699.991970	5475-5725	PASS



IEEE 802.11n HT 20 MHz mode / 5745 ~ 5825MHz (Low)

Environment Temperature (°C)	Volage (V)	Measured Frequency (MHz)	limit Range	Test Result
50	120	5744.964862	5725-5850	PASS
40	120	5744.954443	5725-5850	PASS
30	120	5744.994669	5725-5850	PASS
20	120	5744.997698	5725-5850	PASS
10	120	5744.981502	5725-5850	PASS
0	120	5744.974265	5725-5850	PASS
-10	120	5744.984098	5725-5850	PASS
-20	120	5744.961486	5725-5850	PASS

Environment Temperature (°C)	Volage (V)	Measured Frequency (MHz)	limit Range	Test Result
20	108	5744.979022	5725-5850	PASS
	120	5744.997698	5725-5850	PASS
	132	5744.970777	5725-5850	PASS

IEEE 802.11n HT 20 MHz mode / 5745 ~ 5825MHz (High)

Environment Temperature (°C)	Volage (V)	Measured Frequency (MHz)	limit Range	Test Result
50	120	5824.958714	5725-5850	PASS
40	120	5824.987253	5725-5850	PASS
30	120	5824.995774	5725-5850	PASS
20	120	5824.976980	5725-5850	PASS
10	120	5824.983929	5725-5850	PASS
0	120	5824.985303	5725-5850	PASS
-10	120	5824.981101	5725-5850	PASS
-20	120	5824.991007	5725-5850	PASS

Environment Temperature (°C)	Volage (V)	Measured Frequency (MHz)	limit Range	Test Result
20	108	5824.981108	5725-5850	PASS
	120	5824.976980	5725-5850	PASS
	132	5824.964368	5725-5850	PASS



IEEE 802.11n HT 40 MHz mode / 5190 ~ 5230MHz (Low)

Environment Temperature (°C)	Volage (V)	Measured Frequency (MHz)	limit Range	Test Result
50	120	5189.949712	5150-5250	PASS
40	120	5189.950223	5150-5250	PASS
30	120	5189.972527	5150-5250	PASS
20	120	5189.978642	5150-5250	PASS
10	120	5189.988777	5150-5250	PASS
0	120	5189.985577	5150-5250	PASS
-10	120	5189.962677	5150-5250	PASS
-20	120	5189.992409	5150-5250	PASS

Environment Temperature (°C)	Volage (V)	Measured Frequency (MHz)	limit Range	Test Result
20	108	5189.973124	5150-5250	PASS
	120	5189.978642	5150-5250	PASS
	132	5189.957581	5150-5250	PASS

IEEE 802.11n HT 40 MHz mode / 5190 ~ 5230MHz (High)

Environment Temperature (°C)	Volage (V)	Measured Frequency (MHz)	limit Range	Test Result
50	120	5229.977048	5150-5250	PASS
40	120	5229.994999	5150-5250	PASS
30	120	5229.995838	5150-5250	PASS
20	120	5229.965871	5150-5250	PASS
10	120	5229.960176	5150-5250	PASS
0	120	5229.995486	5150-5250	PASS
-10	120	5229.985103	5150-5250	PASS
-20	120	5229.971658	5150-5250	PASS

Environment Temperature (°C)	Volage (V)	Measured Frequency (MHz)	limit Range	Test Result
20	108	5229.957864	5150-5250	PASS
	120	5229.965871	5150-5250	PASS
	132	5229.951734	5150-5250	PASS



IEEE 802.11n HT 40 MHz mode / 5270 ~ 5310MHz (Low)

Environment Temperature (°C)	Volage (V)	Measured Frequency (MHz)	limit Range	Test Result
50	120	5269.972443	5250-5350	PASS
40	120	5269.999531	5250-5350	PASS
30	120	5269.964890	5250-5350	PASS
20	120	5270.004580	5250-5350	PASS
10	120	5269.953672	5250-5350	PASS
0	120	5269.967857	5250-5350	PASS
-10	120	5269.999747	5250-5350	PASS
-20	120	5269.985008	5250-5350	PASS

Environment Temperature (°C)	Volage (V)	Measured Frequency (MHz)	limit Range	Test Result
20	108	5269.965426	5250-5350	PASS
	120	5270.004580	5250-5350	PASS
	132	5269.950695	5250-5350	PASS

IEEE 802.11n HT 40 MHz mode / 5270 ~ 5310MHz (High)

Environment Temperature (°C)	Volage (V)	Measured Frequency (MHz)	limit Range	Test Result
50	120	5309.975244	5250-5350	PASS
40	120	5309.951753	5250-5350	PASS
30	120	5309.963890	5250-5350	PASS
20	120	5310.044687	5250-5350	PASS
10	120	5309.955048	5250-5350	PASS
0	120	5309.993833	5250-5350	PASS
-10	120	5309.955989	5250-5350	PASS
-20	120	5309.965817	5250-5350	PASS

Environment Temperature (°C)	Volage (V)	Measured Frequency (MHz)	limit Range	Test Result
20	108	5309.984173	5250-5350	PASS
	120	5310.044687	5250-5350	PASS
	132	5309.964057	5250-5350	PASS



IEEE 802.11n HT 40 MHz mode / 5510 ~ 5670MHz (Low)

Environment Temperature (°C)	Volage (V)	Measured Frequency (MHz)	limit Range	Test Result
50	120	5509.971029	5475-5725	PASS
40	120	5509.953161	5475-5725	PASS
30	120	5509.968611	5475-5725	PASS
20	120	5509.986572	5475-5725	PASS
10	120	5509.955125	5475-5725	PASS
0	120	5509.959565	5475-5725	PASS
-10	120	5509.960927	5475-5725	PASS
-20	120	5509.968496	5475-5725	PASS

Environment Temperature (°C)	Volage (V)	Measured Frequency (MHz)	limit Range	Test Result
20	108	5509.997740	5475-5725	PASS
	120	5509.986572	5475-5725	PASS
	132	5509.950537	5475-5725	PASS

IEEE 802.11n HT 40 MHz mode / 5510 ~ 5670MHz (High)

Environment Temperature (°C)	Volage (V)	Measured Frequency (MHz)	limit Range	Test Result
50	120	5669.996021	5475-5725	PASS
40	120	5669.972981	5475-5725	PASS
30	120	5669.976587	5475-5725	PASS
20	120	5670.006784	5475-5725	PASS
10	120	5669.951317	5475-5725	PASS
0	120	5669.958493	5475-5725	PASS
-10	120	5669.967868	5475-5725	PASS
-20	120	5669.952035	5475-5725	PASS

Environment Temperature (°C)	Volage (V)	Measured Frequency (MHz)	limit Range	Test Result
20	108	5669.953337	5475-5725	PASS
	120	5670.006784	5475-5725	PASS
	132	5669.996949	5475-5725	PASS



IEEE 802.11n HT 40 MHz mode / 5755 ~ 5795MHz (Low)

Environment Temperature (°C)	Volage (V)	Measured Frequency (MHz)	limit Range	Test Result
50	120	5754.989934	5725-5850	PASS
40	120	5754.973943	5725-5850	PASS
30	120	5754.965410	5725-5850	PASS
20	120	5754.996578	5725-5850	PASS
10	120	5754.973933	5725-5850	PASS
0	120	5754.967886	5725-5850	PASS
-10	120	5754.978462	5725-5850	PASS
-20	120	5754.983775	5725-5850	PASS

Environment Temperature (°C)	Volage (V)	Measured Frequency (MHz)	limit Range	Test Result
20	108	5754.959443	5725-5850	PASS
	120	5754.996578	5725-5850	PASS
	132	5754.979616	5725-5850	PASS

IEEE 802.11n HT 40 MHz mode / 5755 ~ 5795MHz (High)

Environment Temperature (°C)	Volage (V)	Measured Frequency (MHz)	limit Range	Test Result
50	120	5794.982577	5725-5850	PASS
40	120	5794.979383	5725-5850	PASS
30	120	5794.967425	5725-5850	PASS
20	120	5794.986975	5725-5850	PASS
10	120	5794.954781	5725-5850	PASS
0	120	5794.993655	5725-5850	PASS
-10	120	5794.960441	5725-5850	PASS
-20	120	5794.951399	5725-5850	PASS

Environment Temperature (°C)	Volage (V)	Measured Frequency (MHz)	limit Range	Test Result
20	108	5794.991786	5725-5850	PASS
	120	5794.986975	5725-5850	PASS
	132	5794.960811	5725-5850	PASS