



Test Report

FCC Part15 Subpart C & RSS-247 Issue 2

Product Name : Wireless Access Point
Model No. : AP460SC
FCC ID : QXO-AP460SC
IC : 4141B-AP460SC

Applicant : Extreme Networks, Inc
Address : 6480 Via Del Oro, San Jose, CA
95119 USA

Date of Receipt : May. 11, 2020
Test Date : Oct. 14, 2019 ~ Jul. 23, 2020
Issued Date : Jul. 23, 2020
Report No. : 2032034R-RF-US-P06V02
Report Version : V 1.0

The test results presented in this report relate only to the object tested.

The measurement result is considered in conformance with the requirement if it is within the prescribed limit, It is not necessary to account the uncertainty associated with the measurement result, unless the specification, standard or customer have special requirements

This report shall not be reproduced, except in full, without the written approval of the Issuing CB Testing Laboratory

This report is not used for social proof in China (or Mainland China) market.

Test Report Certification

Issued Date: Jul. 23, 2020
Report No. : 2032034R-RF-US-P06V02



Product Name : Wireless Access Point
 Applicant : Extreme Networks, Inc
 Address : 6480 Via Del Oro, San Jose, CA 95119 USA
 Manufacturer : Extreme Networks, Inc
 Address : 6480 Via Del Oro, San Jose, CA 95119 USA
 Model No. : AP460SC
 Brand : Extreme Networks
 FCC ID : QXO-AP460SC
 IC : 4141B-AP460SC
 EUT Voltage : DC 37~57V
 Test Voltage : AC 120V/60Hz
 Applicable Standard : FCC CFR Title 47 Part 15 Subpart C
 ANSI C63.10:2013;
 KDB 558074 D01v05r02
 RSS-Gen Issue 5 + Amendment 1/ RSS-247 Issue 2
 Test Result : Complied
 Performed Location : DEKRA Testing & Certification (Suzhou) Co., Ltd.
 No.99 Hongye Rd., Suzhou Industrial Park, Suzhou, 215006,
 Jiangsu, China
 TEL: +86-512-6251-5088 / FAX: +86-512-6251-5098
 FCC Designation Number: CN1199;
 ISED CAB identifier: CN0040

Documented By : 

 (Project Assistant: Kitty Li)

Reviewed By : 

 (Technical Supervisor: Frank He)

Approved By : 

 (Supervisor: Jack Zhang)

TABLE OF CONTENTS

Description	Page
1. General Information.....	6
1.1. EUT Description	6
1.2. Working Frequency of Each Channel:	7
1.3. Antenna information	8
1.4. Mode of Operation.....	9
1.5. Tested System Details	9
1.6. Configuration of Tested System.....	10
1.7. EUT Exercise Software.....	11
2. Technical Test	12
2.1. Summary of Test Result.....	12
2.2. Test Frequency configuration:.....	14
2.3. Test Environment.....	15
2.4. Measurement Uncertainty.....	15
3. AC Power Line Conducted Emission.....	16
3.1. Test Equipment.....	16
3.2. Test Setup	16
3.3. Limit.....	17
3.4. Test Procedure	17
3.5. Test Result.....	18
4. Emissions in restricted frequency bands	20
4.1. Test Equipment.....	20
4.2. Test Setup	21
4.3. Limit.....	22
4.4. Test Procedure	25
4.5. EUT test Axis definition.....	26
4.6. Test Result.....	27
5. Emissions in non-restricted frequency bands	37
5.1. Test Equipment.....	37
5.2. Test Setup	37
5.3. Limit.....	38
5.4. Test Procedure	39
5.5. EUT test Axis definition.....	40
5.6. Test Result.....	41
6. Band Edge.....	42
6.1. Test Equipment.....	42
6.2. Test Setup	43
6.3. Limit.....	43

- 6.4. Test Procedure44
- 6.5. EUT test definition45
- 6.6. Duty Cycle46
- 6.7. Test Result47
- 7. Occupied Bandwidth49
- 7.1. Test Equipment.....49
- 7.2. Test Setup49
- 7.3. Limit.....50
- 7.4. Test Procedure50
- 7.5. EUT test definition51
- 7.6. Test Result.....52
- 8. Fundamental emission output power54
- 8.1. Test Equipment.....54
- 8.2. Test Setup54
- 8.3. Limit.....55
- 8.4. Test Procedure56
- 8.5. EUT test definition57
- 8.6. Test Result.....58
- 9. Power Spectral Density59
- 9.1. Test Equipment.....59
- 9.2. Test Setup59
- 9.3. Limit.....59
- 9.4. Test Procedure60
- 9.5. EUT test definition61
- 9.6. Test Result.....62
- 10. Antenna Requirement.....63
- 10.1. Limit.....63
- 10.2. Antenna Connector Construction.....63

History of This Test Report

REPORT NO.	VERSION	DESCRIPTION	ISSUED DATE
2032034R-RF-US-P06V02	V1.0	Initial Issued Report	Jul. 23, 2020

1. General Information

1.1. EUT Description

Product Name	Wireless Access Point
Model No.	AP460SC
EUT Voltage	DC 37~57V
Test Voltage	AC 120V/60Hz
Bluetooth Specification	V4.0
Frequency Range	2402 - 2480 MHz
Channel Number	40
Channel Separation	2MHz
Type of Modulation	GFSK
Data Rate	1Mbps
Antenna Type	Reference to Antenna List
Peak Antenna Gain	Reference to Antenna List

Note: Model AP460SC have two antenna configurations called AP460S6C and AP460S12C, they are the same except the antenna type and antenna gain. We evaluated AP460S6C for conducted test item, AP460S6C, AP460S12C for radiated test item and conducted emission, shown in the report is the worst data of AP460S6C, AP460S12C.

1.2. Working Frequency of Each Channel:

Bluetooth Working Frequency of Each Channel:							
Channel	Frequency	Channel	Frequency	Channel	Frequency	Channel	Frequency
00	2402 MHz	01	2404 MHz	02	2406 MHz	03	2408 MHz
04	2410 MHz	05	2412 MHz	06	2414 MHz	07	2416 MHz
08	2418 MHz	09	2420 MHz	10	2422 MHz	11	2424 MHz
12	2426 MHz	13	2428 MHz	14	2430 MHz	15	2432 MHz
16	2434 MHz	17	2436 MHz	18	2438 MHz	19	2440 MHz
20	2442 MHz	21	2444 MHz	22	2446 MHz	23	2448 MHz
24	2450 MHz	25	2452 MHz	26	2454 MHz	27	2456 MHz
28	2458 MHz	29	2460 MHz	30	2462 MHz	31	2464 MHz
32	2466 MHz	33	2468 MHz	34	2470 MHz	35	2472 MHz
36	2474 MHz	37	2476 MHz	38	2478 MHz	39	2480 MHz

1.3. Antenna information

AP460S6C:

Antenna Model No.	N/A					
Antenna Manufacturer	N/A					
Antenna Delivery	<input checked="" type="checkbox"/>	1*TX+1*RX	<input type="checkbox"/>	2*TX+2*RX	<input type="checkbox"/>	3*TX+3*RX
Antenna Technology	<input checked="" type="checkbox"/>	SISO				
	<input type="checkbox"/>	MIMO	<input type="checkbox"/>	Basic methodology		
			<input type="checkbox"/>	Sectorized antenna systems		
			<input type="checkbox"/>	Cross-polarized antennas		
			<input type="checkbox"/>	Unequal antenna gains, with equal transmit powers		
			<input type="checkbox"/>	Spatial Multiplexing		
<input type="checkbox"/>	Cyclic Delay Diversity (CDD)					
Antenna Type	PIFA					
Antenna 3(Radio 3) Gain	7.90 dBi					

AP460S12C:

Antenna Model No.	N/A					
Antenna Manufacturer	N/A					
Antenna Delivery	<input checked="" type="checkbox"/>	1*TX+1*RX	<input type="checkbox"/>	2*TX+2*RX	<input type="checkbox"/>	3*TX+3*RX
Antenna Technology	<input checked="" type="checkbox"/>	SISO				
	<input type="checkbox"/>	MIMO	<input type="checkbox"/>	Basic methodology		
			<input type="checkbox"/>	Sectorized antenna systems		
			<input type="checkbox"/>	Cross-polarized antennas		
			<input type="checkbox"/>	Unequal antenna gains, with equal transmit powers		
			<input type="checkbox"/>	Spatial Multiplexing		
<input type="checkbox"/>	Cyclic Delay Diversity (CDD)					
Antenna Type	PIFA					
Antenna 3(Radio 3) Gain	6.63 dBi					

1.4. Mode of Operation

Test Mode
Mode 1: Transmit-1Mbps(GFSK_BLE)

1.5. Tested System Details

The types for all equipment, plus descriptions of all cables used in the tested system (including inserted cards) are:

No.	Product	Manufacturer	Model No.	Serial No.	Power Cord
1	Notebook	Think Pad	2526	LV-A3285	Power by adapter
A	LAN Cable	N/A	N/A	N/A	Shield, 0.75m
B	LAN Cable	N/A	N/A	N/A	Shield, 10m

1.6. Configuration of Tested System

Test setup Diagram- AC Line Conducted Emission Test

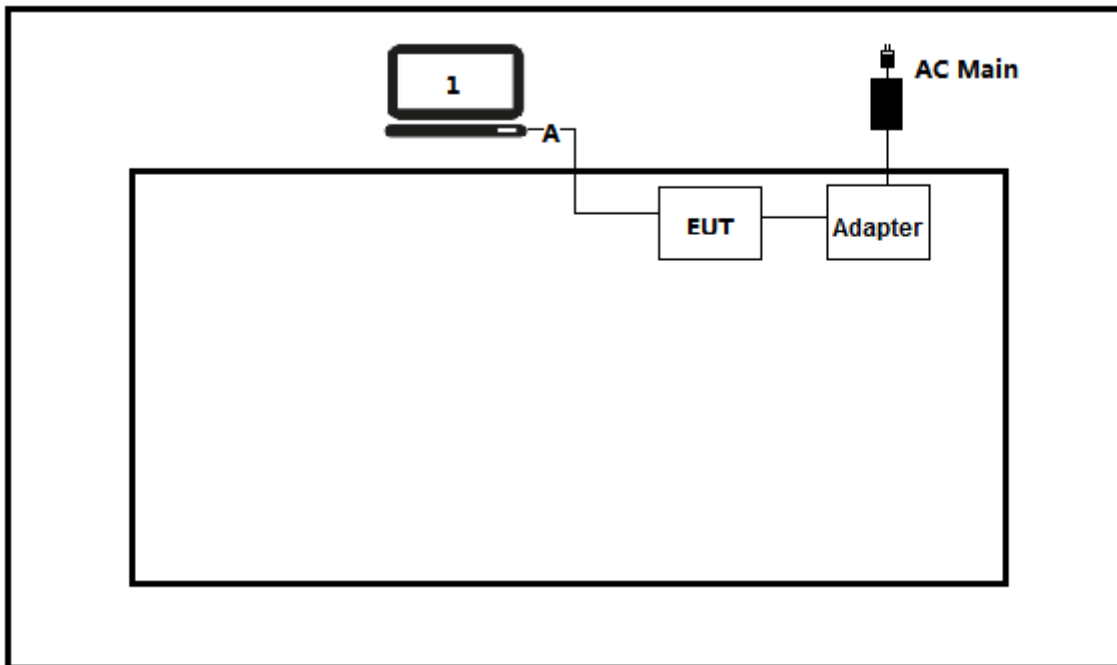

Test setup Diagram- Radiated Emission

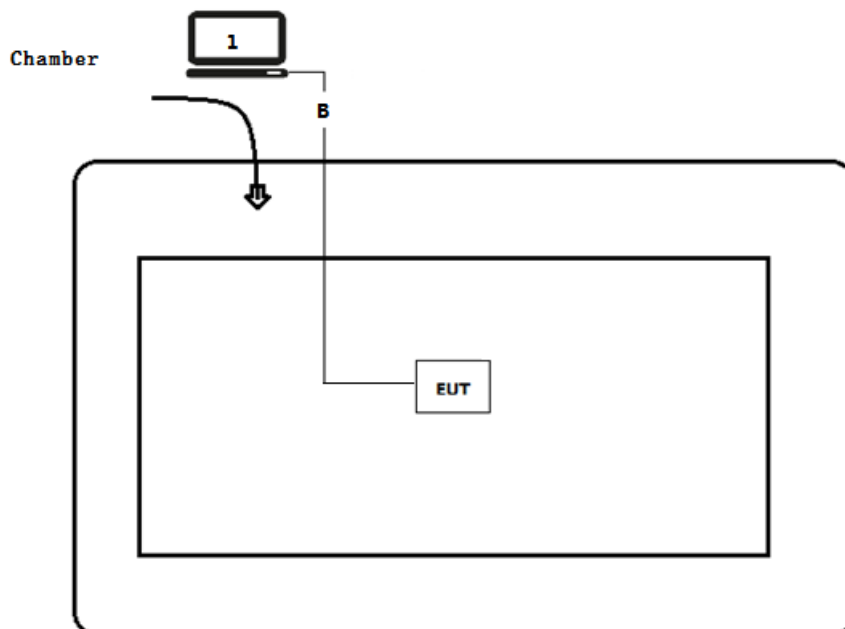

1.7. EUT Exercise Software

1	Setup the EUT and simulators as shown on above.
2	Turn on the power of all equipment.
3	Run RF software [Mtool], and set the test mode and channel, then press OK to start to continue transmit.

2. Technical Test

2.1. Summary of Test Result

For FCC

Performed Test Item	Normative References	Limit	Result
AC Power Line Conducted Emission	FCC CFR Title 47 Part 15 Subpart C: Section 15.207	FCC 15.207	PASS
Emissions in restricted frequency bands	FCC CFR Title 47 Part 15 Subpart C: Section 15.209	FCC 15.209	PASS
Emissions in non-restricted frequency bands	FCC CFR Title 47 Part 15 Subpart C: Section 15.247(d)	$\geq 20\text{dBc}$	PASS
Radiated Emission Band Edge	FCC CFR Title 47 Part 15 Subpart C: Section 15.205	FCC 15.209	PASS
Occupied Bandwidth	FCC CFR Title 47 Part 15 Subpart C: Section 15.247(a)(2)	$\geq 500\text{kHz}$	PASS
Fundamental emission output power	FCC CFR Title 47 Part 15 Subpart C: Section 15.247(b)(3)	$\leq 30\text{dBm}$	PASS
Power Spectral Density	FCC CFR Title 47 Part 15 Subpart C: Section 15.247(e)	$\leq 8\text{dBm}/3\text{kHz}$	PASS
Antenna Requirement	FCC CFR Title 47 Part 15 Subpart C: Section 15.203	FCC 15.203	PASS

For ISED

Performed Test Item	Normative References	Limit	Result
AC Power Line Conducted Emission	RSS-Gen Issue 5 Section 8.8	RSS-Gen	PASS
Emissions in restricted frequency bands	RSS-Gen Issue 5 Section 8.9	RSS-Gen	PASS
Emissions in non-restricted frequency bands	RSS-247 Issue 2 Section 5.5	$\geq 20\text{dBc}$	PASS
Radiated Emission Band Edge	RSS-Gen Issue 5 Section 8.10	RSS-247	PASS
Occupied Bandwidth	RSS-Gen Issue 5 Section 6.7 RSS-247 Issue 2 Section 5.2(a)	$\geq 500\text{kHz}$	PASS
Fundamental emission output power	RSS-247 Issue 2 Section 5.4(d)	$\leq 30\text{dBm}$	PASS
Power Spectral Density	RSS-247 Issue 2 Section 5.2(b)	$\leq 8\text{dBm}/3\text{kHz}$	PASS
Antenna Requirement	RSS-Gen Issue 5 Section 6.8	RSS-Gen Issue 5	PASS

2.2. Test Frequency configuration:

Modulation Mode	Channel	Frequency	Channel	Frequency	Channel	Frequency
BLE	00	2402 MHz	19	2440 MHz	39	2480MHz

2.3. Test Environment

Items	Required (IEC 68-1)	Actual
Temperature (°C)	15-35	21
Humidity (%RH)	25-75	50
Barometric pressure (mbar)	860-1060	950-1000

2.4. Measurement Uncertainty

Test Items	Uncertainty
AC Power Line Conducted Emission	± 2.02 dB
Radiated Emission	Below 1GHz ± 3.8 dB
	Above 1GHz ± 3.9 dB
RF Antenna Port Conducted Emission	± 1.27 dB
Radiated Emission Band Edge	± 3.9 dB
Occupied Bandwidth	± 1 kHz
Power Spectral Density	± 1.27 dB

3. AC Power Line Conducted Emission

3.1. Test Equipment

AC Power Line Conducted Emission / TR-1					
Instrument	Manufacturer	Type No.	Serial No.	Cal. Date	Cal. Due Date
EMI Test Receiver	R&S	ESCI	100906	2020.04.18	2021.04.17
Two-Line V-Network	R&S	ENV 216	101189	2019.10.16	2020.10.15
Two-Line V-Network	R&S	ENV 216	101044	2020.04.18	2021.04.17
50ohm Coaxial Switch	Anritsu	MP59B	6200464462	N/A	N/A
50ohm Termination	SHX	TF2	7081402	2019.09.02	2020.09.01
Temperature/Humidity Meter	RTS	RTS-8S	TR1-TH	2019.08.21	2020.08.20

Note: All equipment are calibrated with traceable calibrations. Each calibration is traceable to the national or international standards.

3.2. Test Setup

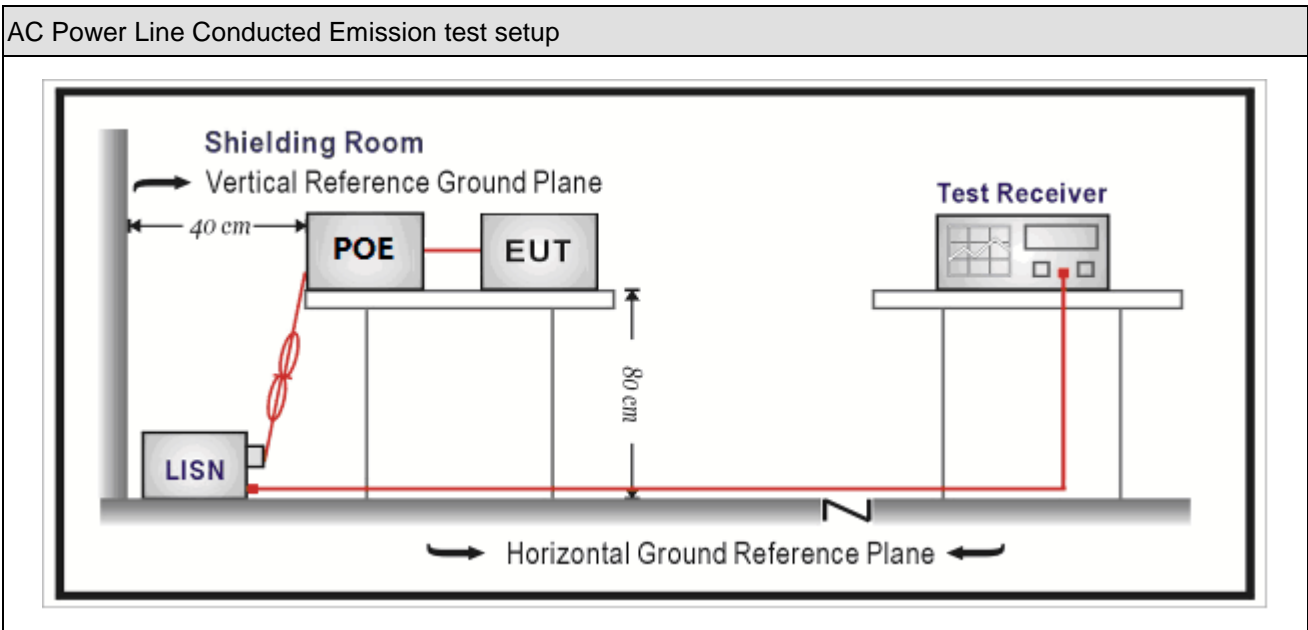

3.3. Limit

Frequency of Emission (MHz)	Conducted Limit	
	Quasi-peak (dBµV)	Average(dBµV)
0.15-0.5	66 to 56	56 to 46
0.5-5	56	46
5-30	60	50

Note 1: The lower limit shall apply at the transition frequencies.
 Note 2: The limit decreases linearly with the logarithm of the frequency in the range 0.15 MHz to 0.5 MHz.

3.4. Test Procedure

Test Method			
	References Rule	Chapter	Item
<input checked="" type="checkbox"/>	ANSI C63.10-2013	6.2	Standard test method for ac power-line conducted emissions from unlicensed wireless devices

3.5. Test Result

Profile: 2032034R	Page No.: 1
Engineer: Neil	
Site: TR1	Time: 2020/07/23 - 04:25
Limit: FCC_Part15.207_CE_AC Power	Margin: 0
Probe: ENV216_101190(0.009-30MHz)	Polarity: Line
EUT: Wireless Access Point	Power: 120V/60Hz
Note: Simultaneous transmission with 2.4G WIFI + 5G WIFI + BLE	

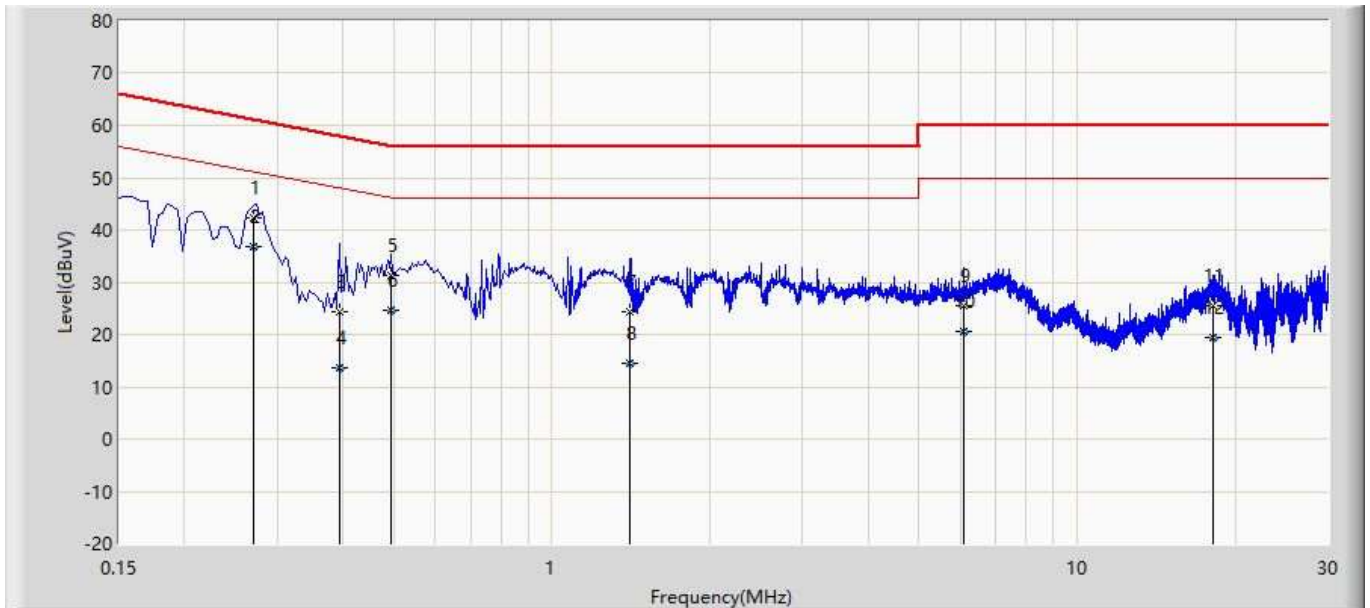

No	Mark	Frequency (MHz)	Measure Level (dBuV)	Reading Level (dBuV)	Over Limit (dB)	Limit (dBuV)	Factor (dB)	Type
1		0.270	42.302	32.675	-18.816	61.118	9.627	QP
2	*	0.270	36.880	27.252	-14.238	51.118	9.627	AV
3		0.394	24.400	14.759	-33.579	57.979	9.641	QP
4		0.394	13.518	3.878	-34.461	47.979	9.641	AV
5		0.494	31.421	21.768	-24.680	56.100	9.652	QP
6		0.494	24.511	14.858	-21.589	46.100	9.652	AV
7		1.406	24.296	14.592	-31.704	56.000	9.704	QP
8		1.406	14.444	4.740	-31.556	46.000	9.704	AV
9		6.090	25.486	15.586	-34.514	60.000	9.900	QP
10		6.090	20.722	10.822	-29.278	50.000	9.900	AV
11		18.091	25.650	15.429	-34.350	60.000	10.221	QP
12		18.091	19.486	9.265	-30.514	50.000	10.221	AV

Profile: 2032034R	Page No.: 2
Engineer: Neil	
Site: TR1	Time: 2020/07/23 - 04:30
Limit: FCC_Part15.207_CE_AC Power	Margin: 0
Probe: ENV216_101190(0.009-30MHz)	Polarity: Neutral
EUT: Wireless Access Point	Power: 120V/60Hz
Note: Simultaneous transmission with 2.4G WIFI + 5G WIFI + BLE	

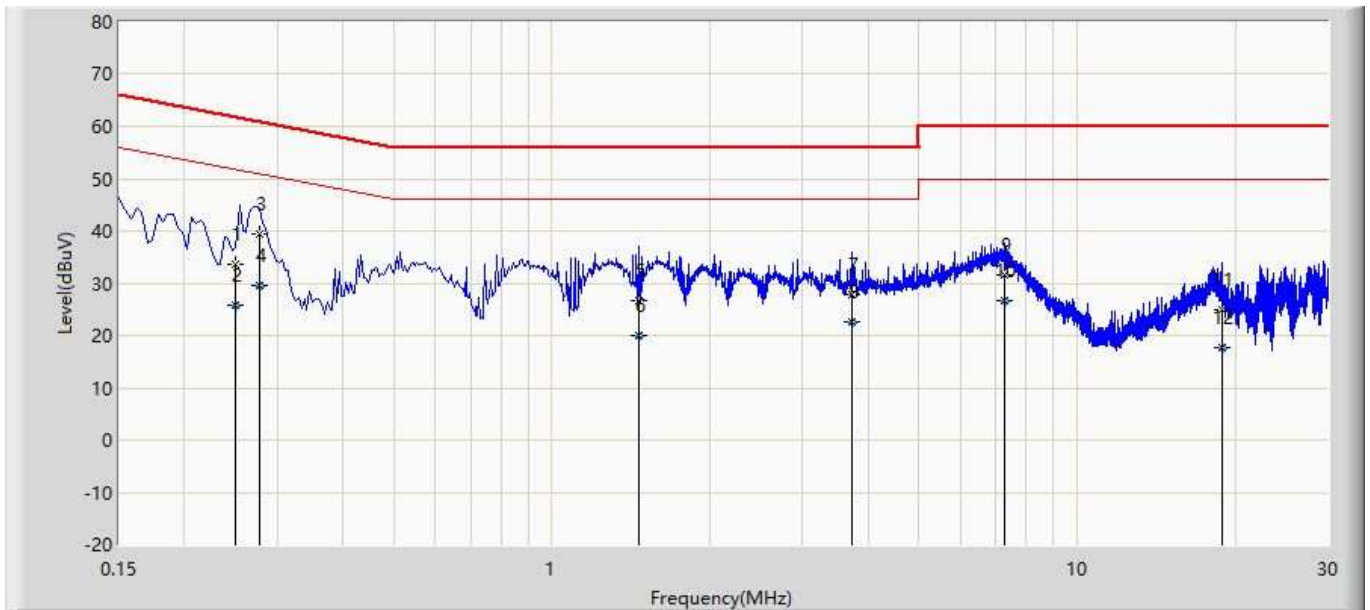

No	Mark	Frequency (MHz)	Measure Level (dBuV)	Reading Level (dBuV)	Over Limit (dB)	Limit (dBuV)	Factor (dB)	Type
1		0.249	33.540	23.916	-28.259	61.799	9.624	QP
2		0.249	25.825	16.202	-25.974	51.799	9.624	AV
3		0.278	39.354	29.726	-21.521	60.875	9.628	QP
4	*	0.278	29.524	19.896	-21.351	50.875	9.628	AV
5		1.466	26.575	16.872	-29.425	56.000	9.703	QP
6		1.466	19.968	10.265	-26.032	46.000	9.703	AV
7		3.718	27.968	18.170	-28.032	56.000	9.798	QP
8		3.718	22.723	12.926	-23.277	46.000	9.798	AV
9		7.290	31.629	21.670	-28.371	60.000	9.959	QP
10		7.290	26.672	16.713	-23.328	50.000	9.959	AV
11		18.822	24.827	14.536	-35.173	60.000	10.291	QP
12		18.822	17.664	7.374	-32.336	50.000	10.291	AV

4. Emissions in restricted frequency bands

4.1. Test Equipment

Radiated Emission(Below 1GHz) / AC-2					
Instrument	Manufacturer	Type No.	Serial No.	Cal. Date	Cal. Due Date
EMI Test Receiver	R&S	ESCI	100573	2019.12.28	2020.12.27
Loop Antenna	R&S	HFH2-Z2	833799/003	2020.02.17	2021.02.16
Bilog Antenna	Teseq GmbH	CBL6112D	27611	2019.09.23	2020.09.22
Coaxial Cable	Huber+Suhner	SUCOFLEX 106	AC2-C	2020.04.05	2021.04.04
Temperature/Humidity Meter	RTS	RTS-8S	AC2-TH	2019.09.02	2020.09.01

Note: All equipment are calibrated with traceable calibrations. Each calibration is traceable to the national or international standards.

Radiated Emission(Above 1GHz) / AC-5					
Instrument	Manufacturer	Type No.	Serial No.	Cal. Date	Cal. Due Date
Spectrum Analyzer	R&S	FSV	104212	2019.12.28	2020.12.27
Signal analyzer	Agilent	E4446A	MY45300103	2020.05.08	2021.05.07
low Noise Amplifier	BXT	NA2651D	LNA17040209	2020.04.13	2021.04.12
Pre-Amplifier	EMCI	EMC184045SE	980263	2020.05.24	2021.05.23
DRG Horn Antenna	ETS-Lindgren	3117	00167055	2020.05.25	2021.05.24
Broad-Band Horn Antenna	Schwarzbeck	BBHA9170	294	2019.03.23	2021.03.22
Coaxial Cable	Huber+Suhner	SUCOFLEX 106	AC5-C2	2020.04.13	2021.04.12
Coaxial Cable	ROSENBERGER	LA1-C011-2000/3000	AC5-40G	2020.04.18	2021.04.17
Temperature/Humidity Meter	RTS	RTS-8S	AC5-TH	2019.09.02	2020.09.01
Quietek EMI V3(test software)	Quietek	N/A	N/A	N/A	N/A

Note: All equipment is calibrated with traceable calibrations. Each calibration is traceable to the national or international standards.

4.2. Test Setup

Below 30MHz Test Setup:

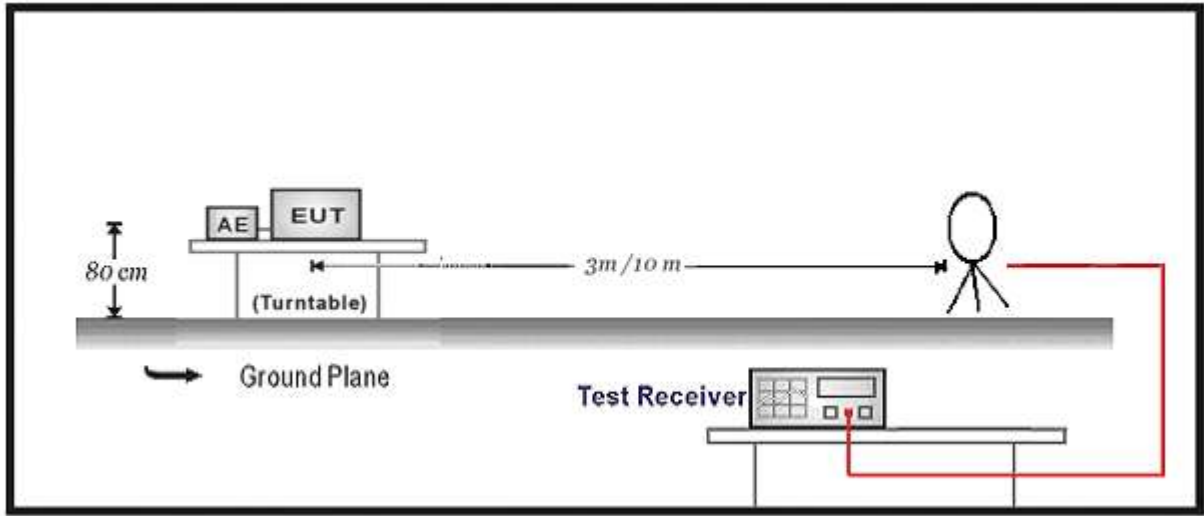

30MHz-1GHz Test Setup:

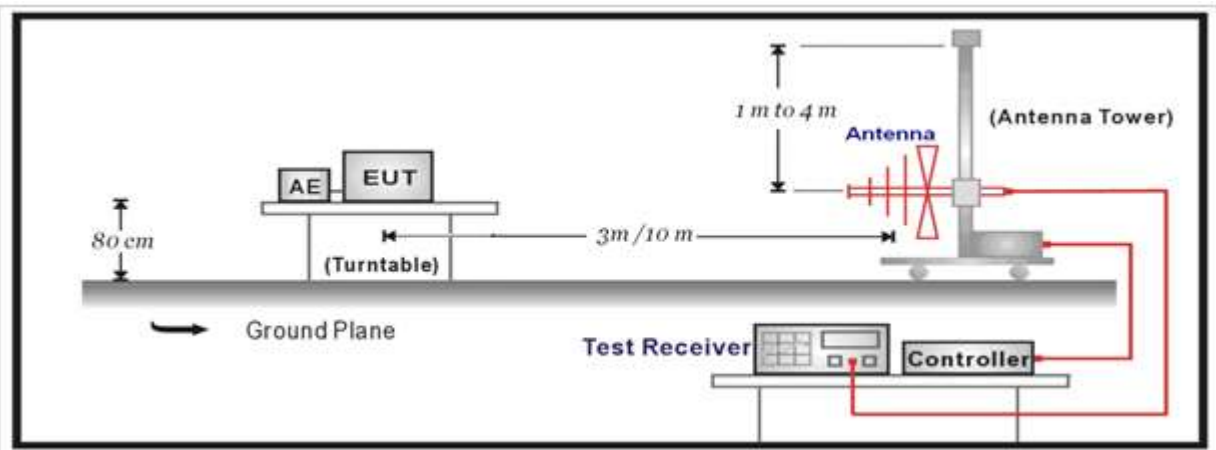

Above 1GHz Test Setup:

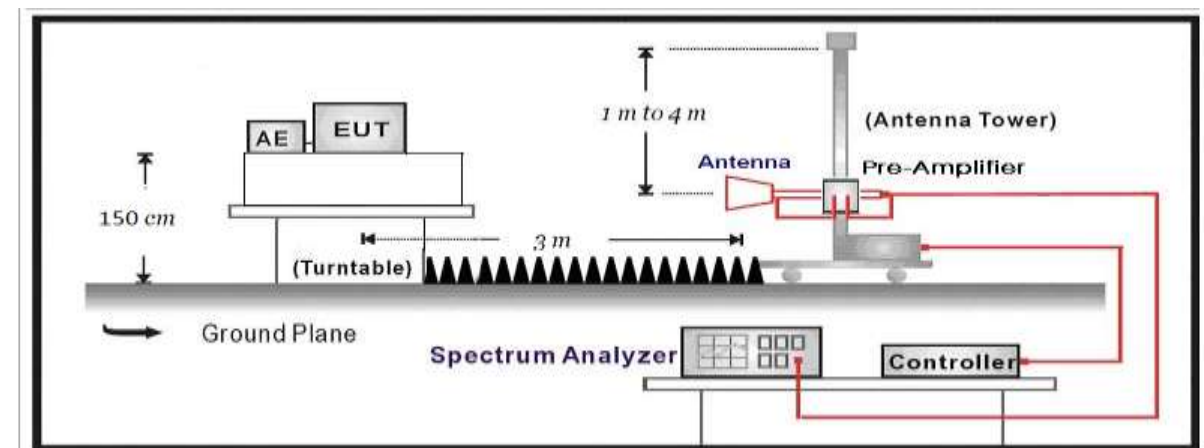

4.3. Limit

For FCC

Restricted Bands of operation			
Frequency (MHz)	Frequency (MHz)	Frequency (MHz)	Frequency (GHz)
0.090 – 0.110	16.42 – 16.423	399.9 – 410	4.5 – 5.15
0.495 – 0.505	16.69475 – 16.69525	608 – 614	5.35 – 5.46
2.1735 – 2.1905	16.80425 – 16.80475	960 – 1240	7.25 – 7.75
4.125 – 4.128	25.5 – 25.67	1300 – 1427	8.025 – 8.5
4.17725 – 4.17775	37.5 – 38.25	1435 – 1626.5	9.0 – 9.2
4.20725 – 4.20775	73 – 74.6	1645.5 – 1646.5	9.3 – 9.5
6.215 – 6.218	74.8 – 75.2	1660 – 1710	10.6 – 12.7
6.26775 – 6.26825	108 – 121.94	1718.8 – 1722.2	13.25 – 13.4
6.31175 – 6.31225	123 – 138	2200 – 2300	14.47 – 14.5
8.291 – 8.294	149.9 – 150.05	2310 – 2390	15.35 – 16.2
8.362 – 8.366	156.52475 – 156.52525	2483.5 – 2500	17.7 – 21.4
8.37625 – 8.38675	156.7 – 156.9	2690 – 2900	22.01 – 23.12
8.81425 – 8.81475	162.0125 – 167.17	3260 – 3267	23.6 – 24.0
12.29 – 12.293	167.72 – 173.2	3332 – 3339	31.2 – 31.8
12.51975 – 12.52025	240 – 285	3345.8 – 3358	36.43 – 36.5
12.57675 – 12.57725	322 – 335.4	3600 – 4400	
13.36 – 13.41			

For IC:

MHz
0.090 - 0.110
0.495 - 0.505
2.1735 - 2.1905
3.020 - 3.026
4.125 - 4.128
4.17725 - 4.17775
4.20725 - 4.20775
5.677 - 5.683
6.215 - 6.218
6.26775 - 6.26825
6.31175 - 6.31225
8.291 - 8.294
8.362 - 8.366
8.37625 - 8.38675
8.41425 - 8.41475
12.29 - 12.293
12.51975 - 12.52025
12.57675 - 12.57725
13.36 - 13.41
16.42 - 16.423
16.69475 - 16.69525
16.80425 - 16.80475
25.5 - 25.67
37.5 - 38.25
73 - 74.6
74.8 - 75.2
108 - 138

MHz
149.9 - 150.05
156.52475 - 156.52525
156.7 - 156.9
162.0125 - 167.17
167.72 - 173.2
240 - 285
322 - 335.4
399.9 - 410
608 - 614
960 - 1427
1435 - 1626.5
1645.5 - 1646.5
1660 - 1710
1718.8 - 1722.2
2200 - 2300
2310 - 2390
2483.5 - 2500
2655 - 2900
3260 - 3267
3332 - 3339
3345.8 - 3358
3500 - 4400
4500 - 5150
5350 - 5460
7250 - 7750
8025 - 8500
--

GHz
9.0 - 9.2
9.3 - 9.5
10.6 - 12.7
13.25 - 13.4
14.47 - 14.5
15.35 - 16.2
17.7 - 21.4
22.01 - 23.12
23.6 - 24.0
31.2 - 31.8
36.43 - 36.5
Above 38.6

* Certain frequency bands listed in table 7 and in bands above 38.6 GHz are designated for licence-exempt applications. These frequency bands and the requirements that apply to related devices are set out in the 200 and 300 series of RSSs.

Restricted Band Emissions Limit			
Frequency (MHz)	Field strength (μV/m)	Field strength (dBμV/m)	Measurement distance (m)
0.009 - 0.49	2400/F(kHz)	48.5 – 13.8	300 _(Note 1)
0.49 - 1.705	24000/F(kHz)	33.8 - 23	30 _(Note 1)
1.705 - 30	30	29.5	30 _(Note 1)
30 - 88	100	40	3 _(Note 2)
88 - 216	150	43.5	3 _(Note 2)
216 - 960	200	46	3 _(Note 2)
Above 960	500	54	3 _(Note 2)





Note 1: At frequencies below 30 MHz, measurements may be performed at a distance closer than that specified in the regulations; however, an attempt should be made to avoid making measurements in the near field. Pending the development of an appropriate measurement procedure for measurements performed below 30 MHz, when performing measurements at a closer distance than specified, the results shall be extrapolated to the specified distance by either making measurements at a minimum of two distances on at least one radial to determine the proper extrapolation factor or by using the square of an inverse linear distance extrapolation factor (40 dB/decade).

Note 2: At frequencies at or above 30 MHz, measurements may be performed at a distance other than what is specified provided: measurements are not made in the near field except where it can be shown that near field measurements are appropriate due to the characteristics of the device; and it can be demonstrated that the signal levels needed to be measured at the distance employed can be detected by the measurement equipment. Measurements shall not be performed at a distance greater than 30 meters unless it can be further demonstrated that measurements at a distance of 30 meters or less are impractical. When performing measurements at a distance other than that specified, the results shall be extrapolated to the specified distance using an extrapolation factor of 20 dB/decade (inverse linear-distance for field strength measurements; inverse-linear-distance-squared for power density measurements).

4.4. Test Procedure

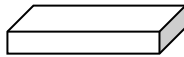
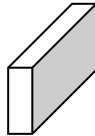
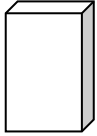
Test Method			
	References Rule	Chapter	Description
<input type="checkbox"/>	ANSI C63.10	11.11	Emissions in non-restricted frequency bands
	<input type="checkbox"/> ANSI C63.10	11.11.2	Reference level measurement
	<input type="checkbox"/> ANSI C63.10	11.11.3	Emission level measurement
<input checked="" type="checkbox"/>	ANSI C63.10	11.12	Emissions in restricted frequency bands
	<input checked="" type="checkbox"/> ANSI C63.10	11.12.1	Radiated emission measurements
	<input checked="" type="checkbox"/> ANSI C63.10	11.12.2.7	Radiated spurious emission test
	<input checked="" type="checkbox"/> ANSI C63.10	6.4	Radiated emissions from unlicensed wireless devices below 30 MHz
	<input checked="" type="checkbox"/> ANSI C63.10	6.5	Radiated emissions from unlicensed wireless devices in the frequency range of 30 MHz to 1000 MHz
	<input checked="" type="checkbox"/> ANSI C63.10	6.6	Radiated emissions from unlicensed wireless devices above 1 GHz
	<input type="checkbox"/> ANSI C63.10	11.12.2.3	Quasi-peak measurement procedure
	<input checked="" type="checkbox"/> ANSI C63.10	11.12.2.4	Peak power measurement procedure
	<input checked="" type="checkbox"/> ANSI C63.10	11.12.2.5	Average power measurement procedures
	<input type="checkbox"/> ANSI C63.10	11.12.2.5.1	Trace averaging with continuous EUT transmission at full power
	<input type="checkbox"/> ANSI C63.10	11.12.2.5.2	Trace averaging across ON and OFF times of the EUT transmissions followed by duty cycle correction
	<input checked="" type="checkbox"/> ANSI C63.10	11.12.2.5.3	Reduced VBW averaging across ON and OFF times of the EUT transmissions with max hold

4.5. EUT test Axis definition

Item	Emissions in restricted frequency bands			
Device Category	<input type="checkbox"/>	Fixed point-to-point		
	<input type="checkbox"/>	Emit multiple directional beams, simultaneously or sequentially		
	<input checked="" type="checkbox"/>	Other cases		
Test mode	Mode 1			
Test method	<input checked="" type="checkbox"/>	Radiated		
		X Axis	Y Axis	Z Axis
				
		Worst Axis <input checked="" type="checkbox"/>	Worst Axis <input type="checkbox"/>	Worst Axis <input type="checkbox"/>
	<input type="checkbox"/>	Conducted		
	<input type="checkbox"/>	Chain 1		
				
	<input type="checkbox"/>	Chain 1	Chain 2	
				
	<input type="checkbox"/>	Chain 1	Chain 2	Chain 3
				

4.6. Test Result

Profile: 2032034R	Page No.: 1
Engineer: Neil	
Site: AC5	Time: 2020/06/18 - 18:38
Limit: FCC_Part15.209_RE(3m)	Margin: 0
Probe: Horn_3117_00167055(1-18GHz)	Polarity: Horizontal
EUT: Wireless Access Point	Power: AC 120V/60Hz
Note: Mode 1:Transmit at 2402MHz by BLE	

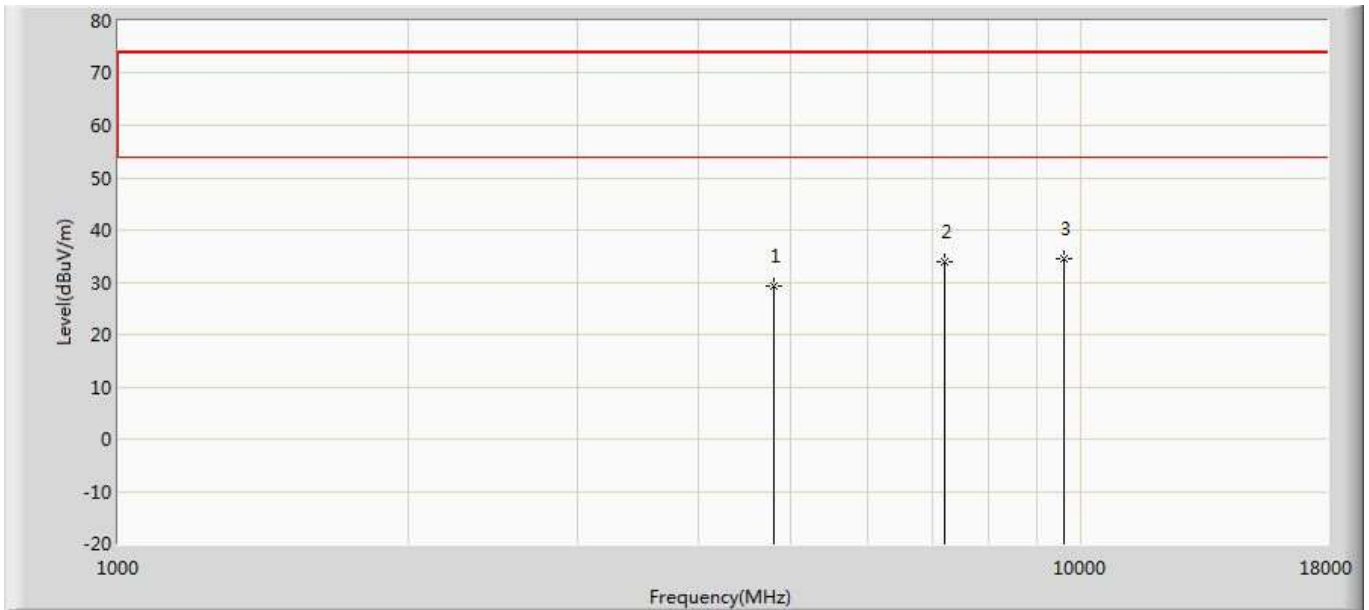

No	Mark	Frequency (MHz)	Measure Level (dBuV/m)	Reading Level (dBuV)	Over Limit (dB)	Limit (dBuV/m)	Factor (dB)	Type
1		4804.000	29.231	25.663	-44.769	74.000	3.568	PK
2		7206.000	33.960	25.688	-40.040	74.000	8.272	PK
3	*	9608.000	34.379	25.811	-39.621	74.000	8.569	PK

Profile: 2032034R	Page No.: 2
Engineer: Neil	
Site: AC5	Time: 2020/06/18 - 18:39
Limit: FCC_Part15.209_RE(3m)	Margin: 0
Probe: Horn_3117_00167055(1-18GHz)	Polarity: Vertical
EUT: Wireless Access Point	Power: AC 120V/60Hz
Note: Mode 1:Transmit at 2402MHz by BLE	

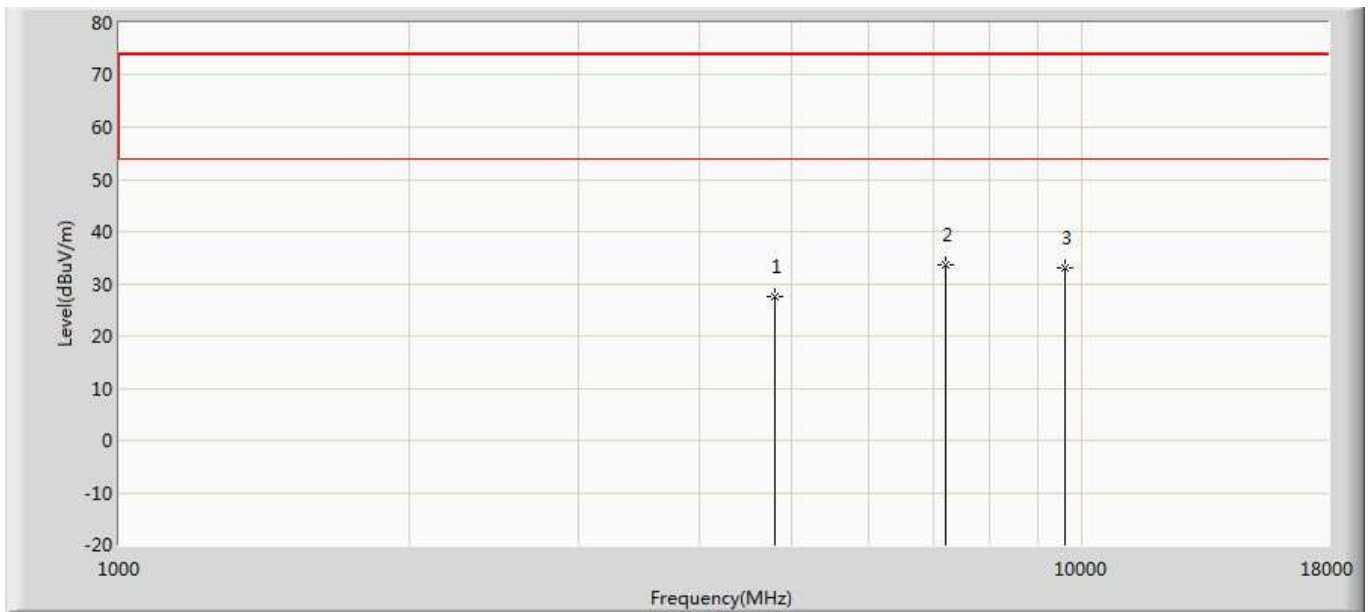

No	Mark	Frequency (MHz)	Measure Level (dBuV/m)	Reading Level (dBuV)	Over Limit (dB)	Limit (dBuV/m)	Factor (dB)	Type
1		4804.000	27.670	24.102	-46.330	74.000	3.568	PK
2	*	7206.000	33.708	25.436	-40.292	74.000	8.272	PK
3		9608.000	33.098	24.530	-40.902	74.000	8.569	PK

Profile: 2032034R	Page No.: 3
Engineer: Neil	
Site: AC5	Time: 2020/06/18 - 18:40
Limit: FCC_Part15.209_RE(3m)	Margin: 0
Probe: Horn_3117_00167055(1-18GHz)	Polarity: Horizontal
EUT: Wireless Access Point	Power: AC 120V/60Hz
Note: Mode 1:Transmit at 2440MHz by BLE	

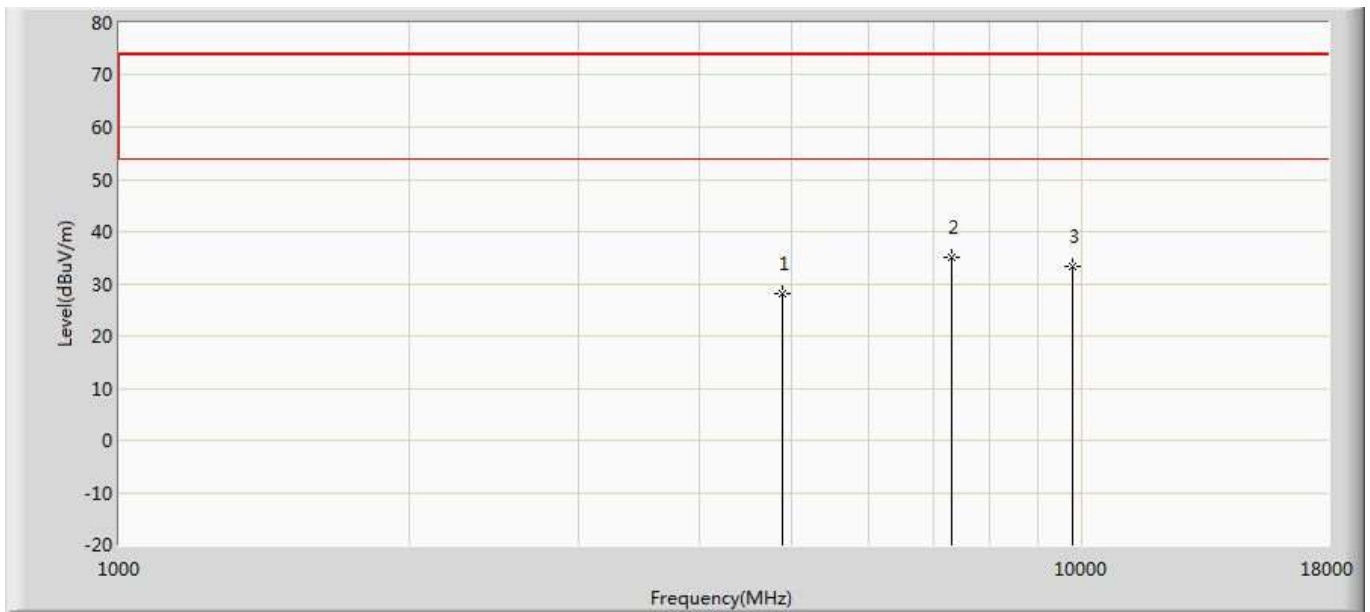

No	Mark	Frequency (MHz)	Measure Level (dBuV/m)	Reading Level (dBuV)	Over Limit (dB)	Limit (dBuV/m)	Factor (dB)	Type
1		4880.000	28.200	24.610	-45.800	74.000	3.590	PK
2	*	7320.000	35.162	26.754	-38.838	74.000	8.408	PK
3		9760.000	33.228	24.288	-40.772	74.000	8.941	PK

Profile: 2032034R	Page No.: 4
Engineer: Neil	
Site: AC5	Time: 2020/06/18 - 18:41
Limit: FCC_Part15.209_RE(3m)	Margin: 0
Probe: Horn_3117_00167055(1-18GHz)	Polarity: Vertical
EUT: Wireless Access Point	Power: AC 120V/60Hz
Note: Mode 1:Transmit at 2440MHz by BLE	

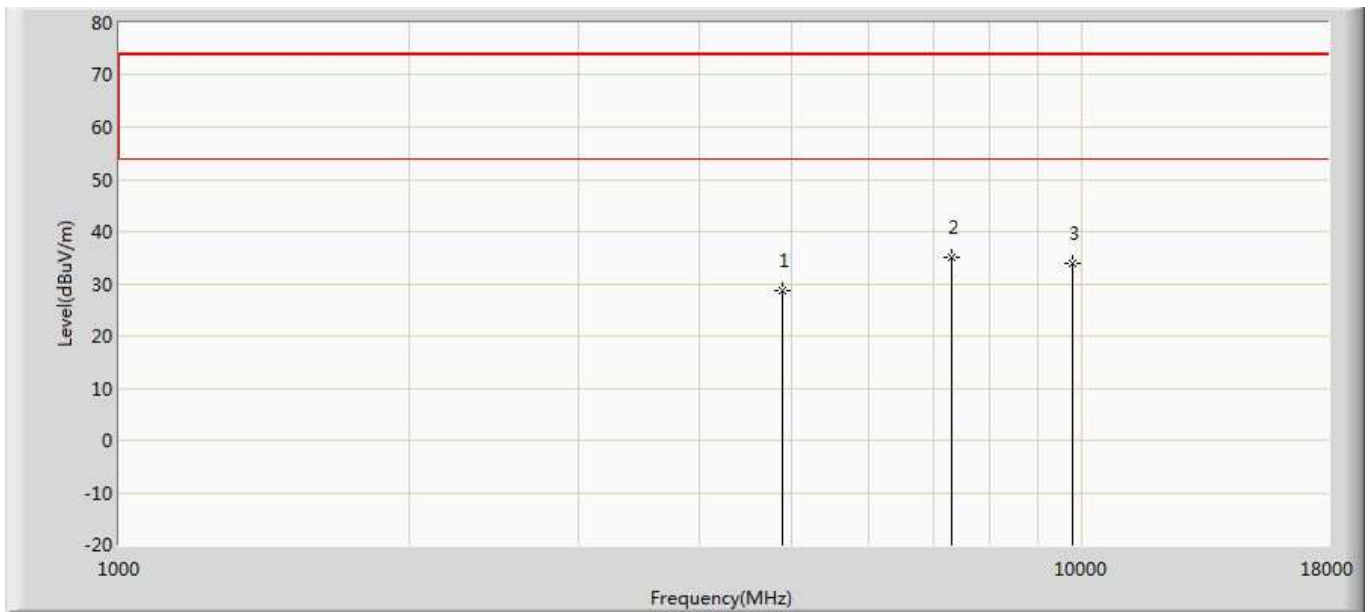

No	Mark	Frequency (MHz)	Measure Level (dBuV/m)	Reading Level (dBuV)	Over Limit (dB)	Limit (dBuV/m)	Factor (dB)	Type
1		4880.000	28.793	25.203	-45.207	74.000	3.590	PK
2	*	7320.000	35.125	26.717	-38.875	74.000	8.408	PK
3		9760.000	33.846	24.906	-40.154	74.000	8.941	PK

Profile: 2032034R	Page No.: 5
Engineer: Neil	
Site: AC5	Time: 2020/06/18 - 18:41
Limit: FCC_Part15.209_RE(3m)	Margin: 0
Probe: Horn_3117_00167055(1-18GHz)	Polarity: Horizontal
EUT: Wireless Access Point	Power: AC 120V/60Hz
Note: Mode 1:Transmit at 2480MHz by BLE	

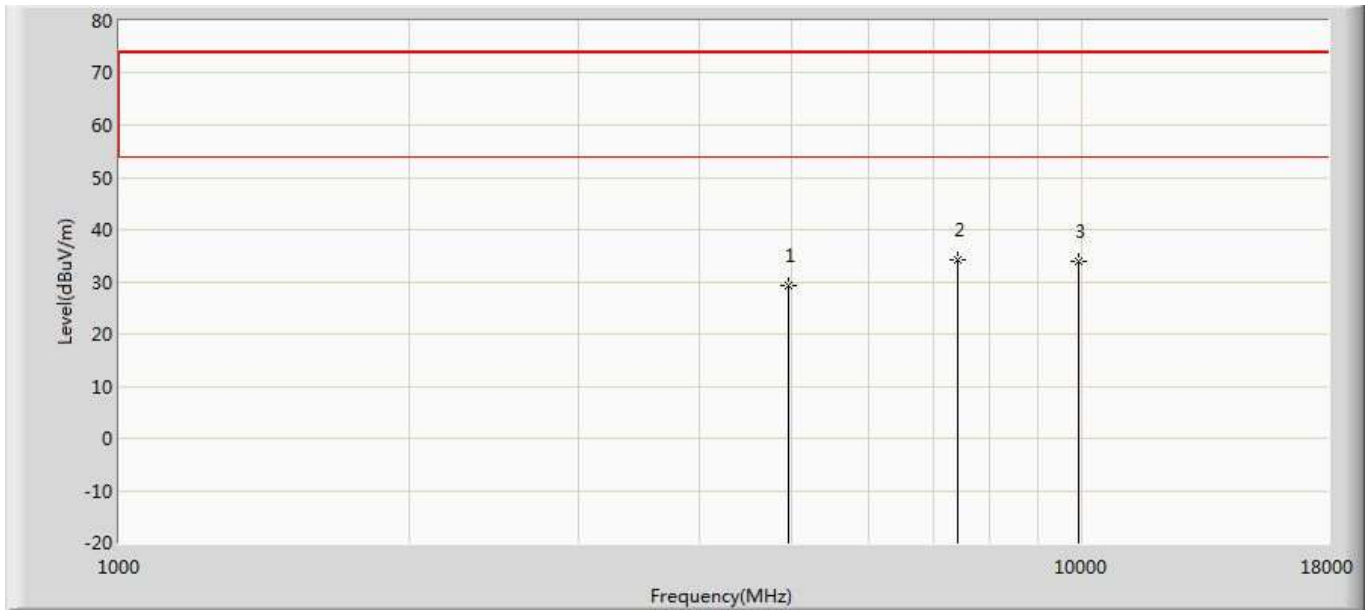

No	Mark	Frequency (MHz)	Measure Level (dBuV/m)	Reading Level (dBuV)	Over Limit (dB)	Limit (dBuV/m)	Factor (dB)	Type
1		4960.000	29.335	25.724	-44.665	74.000	3.610	PK
2	*	7440.000	34.060	26.446	-39.940	74.000	7.614	PK
3		9920.000	33.980	23.943	-40.020	74.000	10.038	PK

Profile: 2032034R	Page No.: 6
Engineer: Neil	
Site: AC5	Time: 2020/06/18 - 18:43
Limit: FCC_Part15.209_RE(3m)	Margin: 0
Probe: Horn_3117_00167055(1-18GHz)	Polarity: Vertical
EUT: Wireless Access Point	Power: AC 120V/60Hz
Note: Mode 1:Transmit at 2480MHz by BLE	

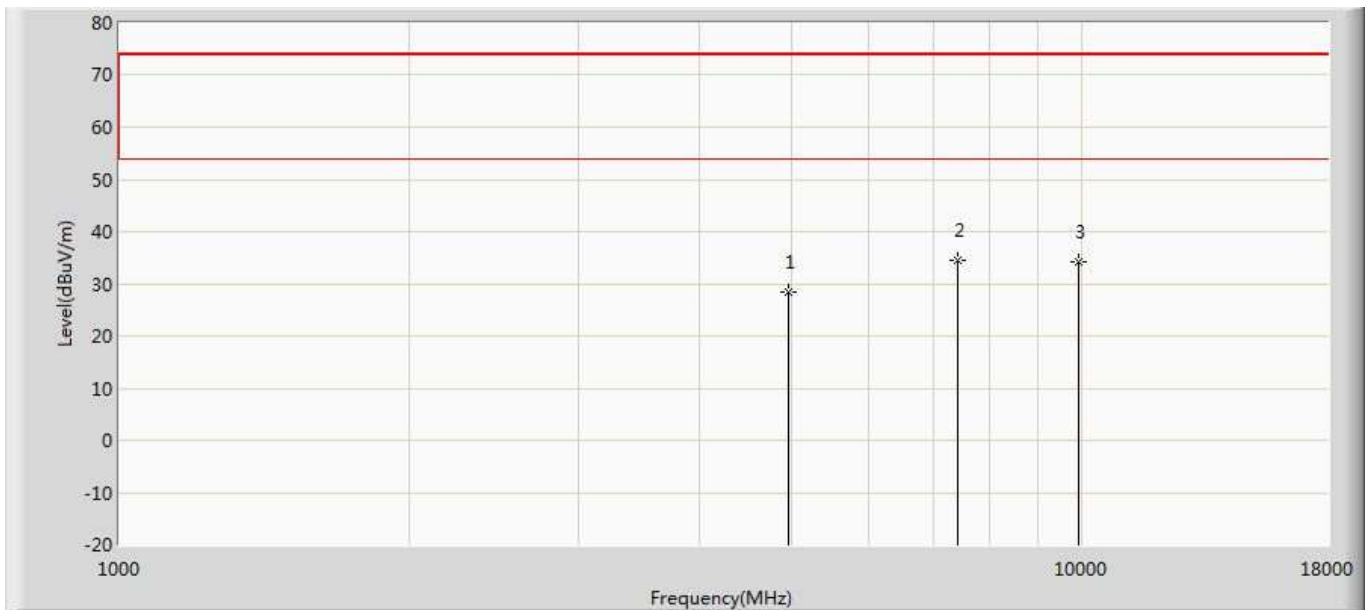

No	Mark	Frequency (MHz)	Measure Level (dBuV/m)	Reading Level (dBuV)	Over Limit (dB)	Limit (dBuV/m)	Factor (dB)	Type
1		4960.000	28.419	24.808	-45.581	74.000	3.610	PK
2	*	7440.000	34.379	26.765	-39.621	74.000	7.614	PK
3		9920.000	34.090	24.053	-39.910	74.000	10.038	PK

Note 1: Measure Level = Reading Level + Factor.

2: The test frequency range, 9kHz~30MHz, 18GHz~25GHz, both of the worst case are at least 6dB below the limits, therefore no data appear in the report.

3: This limit applies for using average detector, if the test result on peak is lower than average limit, then average measurement needn't be performed.

The worst case of Radiated Emission below 1GHz:

Engineer: Beck	
Site: AC3	Time: 2020/06/05
Limit: FCC_Part15.209_RE(3m)	Margin: 0
Probe: AC3_3m (30-1000MHz)	Polarity: Horizontal
EUT: Wireless Access Point	Power: AC 120V/60Hz
Note: Simultaneous transmission with 2.4G WIFI + 5G WIFI + BLE	

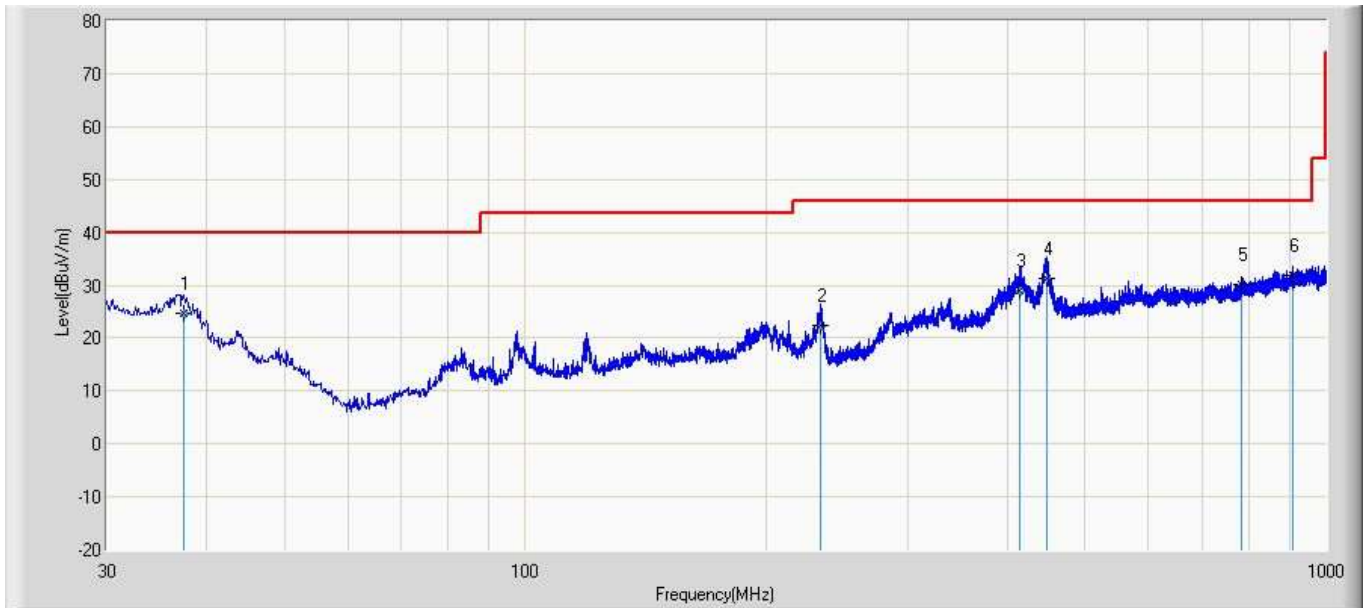

No	Mark	Frequency (MHz)	Measure Level (dBuV/m)	Reading Level (dBuV)	Over Limit (dB)	Limit (dBuV/m)	Probe (dB/m)	Cable (dB)	Amp (dB)	Ant Pos (cm)	Table Pos (deg)	Type
1		37.396	24.621	0.200	-15.379	40.000	17.913	6.508	0.000	100	30	QP
2		233.820	22.270	4.000	-23.730	46.000	10.869	7.401	0.000	100	61	QP
3		414.605	28.887	2.400	-17.113	46.000	18.543	7.944	0.000	100	140	QP
4		447.100	31.381	4.600	-14.619	46.000	18.753	8.028	0.000	100	75	QP
5		784.539	30.075	0.100	-15.925	46.000	21.126	8.849	0.000	100	50	QP
6	*	909.426	31.995	0.100	-14.005	46.000	22.777	9.119	0.000	100	273	QP

Note:

1. " * ", means this data is the worst emission level.
2. Measurement Level = Reading Level + Factor(Probe+Cable-Amp).

Engineer: Beck	
Site: AC3	Time: 2020/06/05
Limit: FCC_Part15.209_RE(3m)	Margin: 0
Probe: AC3_3m (30-1000MHz)	Polarity: Vertical
EUT: Wireless Access Point	Power: AC 120V/60Hz
Note: Simultaneous transmission with 2.4G WIFI + 5G WIFI + BLE	

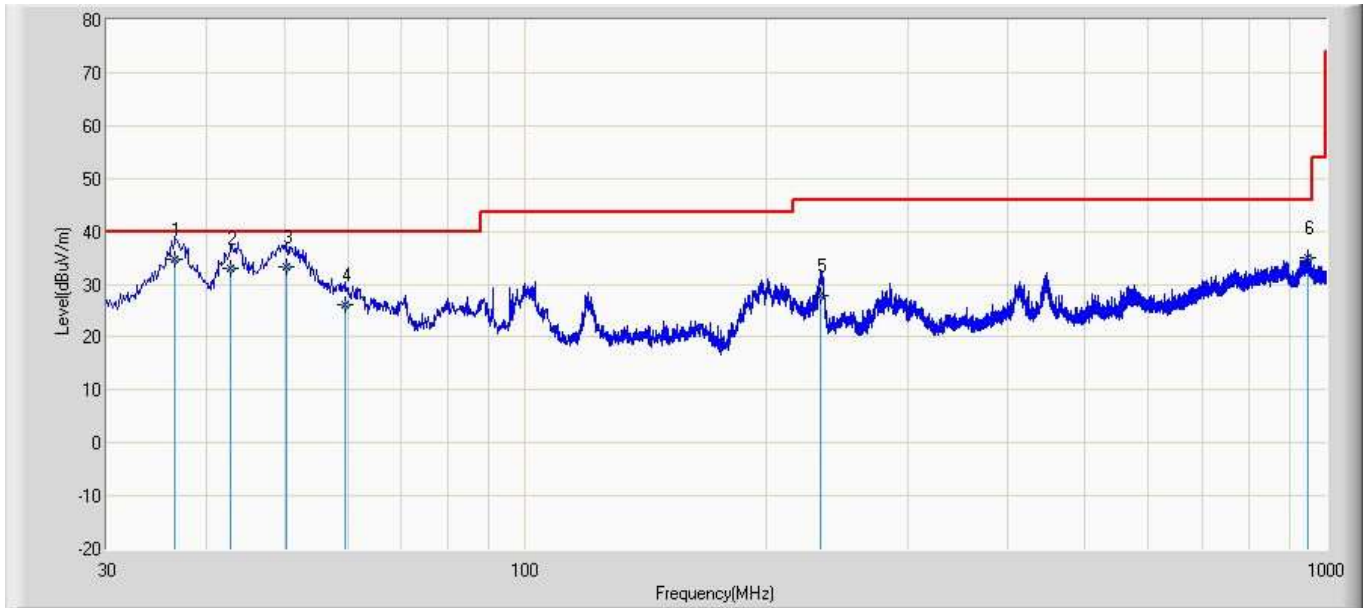

No	Mark	Frequency (MHz)	Measure Level (dBuV/m)	Reading Level (dBuV)	Over Limit (dB)	Limit (dBuV/m)	Probe (dB/m)	Cable (dB)	Amp (dB)	Ant Pos (cm)	Table Pos (deg)	Type
1	*	36.548	34.735	13.000	-5.265	40.000	15.232	6.503	0.000	100	110	QP
2		42.850	32.953	15.200	-7.047	40.000	11.209	6.544	0.000	100	170	QP
3		50.370	33.355	15.200	-6.645	40.000	11.565	6.590	0.000	100	330	QP
4		59.464	26.174	10.000	-13.826	40.000	9.526	6.648	0.000	100	99	QP
5		233.579	27.907	5.300	-18.093	46.000	15.206	7.401	0.000	100	271	QP
6		947.256	34.913	0.100	-11.087	46.000	25.616	9.197	0.000	100	60	QP

Note:

1. " * ", means this data is the worst emission level.
2. Measurement Level = Reading Level + Factor(Probe+Cable-Amp).

The worst case of Simultaneous transmission:

Profile: 2032034R	Page No.: 29
Engineer: Neil	
Site: AC5	Time: 2020/07/22 - 23:09
Limit: FCC_Part15.209_RE(3m)	Margin: 0
Probe: Horn_3117_00167055(1-18GHz)	Polarity: Horizontal
EUT: Wireless Access Point	Power: AC 120V/60Hz
Note: Simultaneous transmission with 2.4G WIFI + 5G WIFI + BLE	

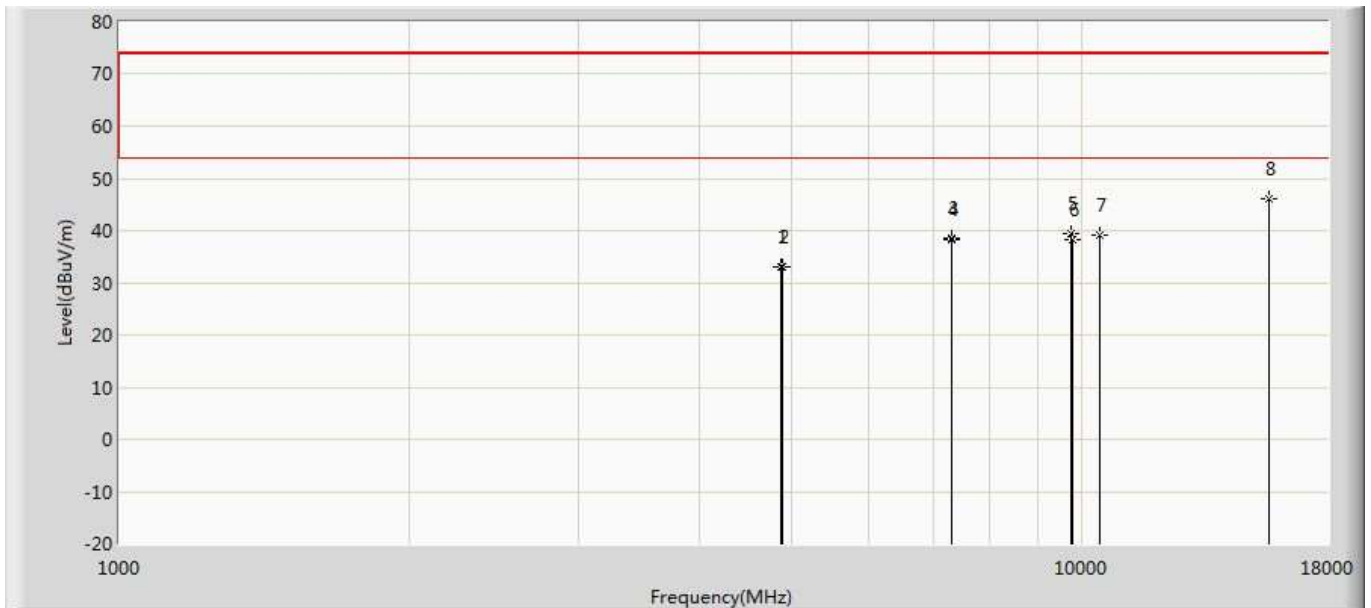

No	Mark	Frequency (MHz)	Measure Level (dBuV/m)	Reading Level (dBuV)	Over Limit (dB)	Limit (dBuV/m)	Factor (dB)	Type
1		4874.000	33.028	29.435	-40.972	74.000	3.593	PK
2		4880.000	33.067	29.477	-40.933	74.000	3.590	PK
3		7311.000	38.654	30.303	-35.346	74.000	8.351	PK
4		7320.000	38.405	29.997	-35.595	74.000	8.408	PK
5		9748.000	39.280	30.339	-34.720	74.000	8.941	PK
6		9760.000	38.168	29.228	-35.832	74.000	8.941	PK
7		10440.000	39.163	28.049	-34.837	74.000	11.114	PK
8	*	15660.000	46.167	29.034	-27.833	74.000	17.133	PK

Profile: 2032034R	Page No.: 30
Engineer: Neil	
Site: AC5	Time: 2020/07/22 - 23:09
Limit: FCC_Part15.209_RE(3m)	Margin: 0
Probe: Horn_3117_00167055(1-18GHz)	Polarity: Vertical
EUT: Wireless Access Point	Power: AC 120V/60Hz
Note: Simultaneous transmission with 2.4G WIFI + 5G WIFI + BLE	

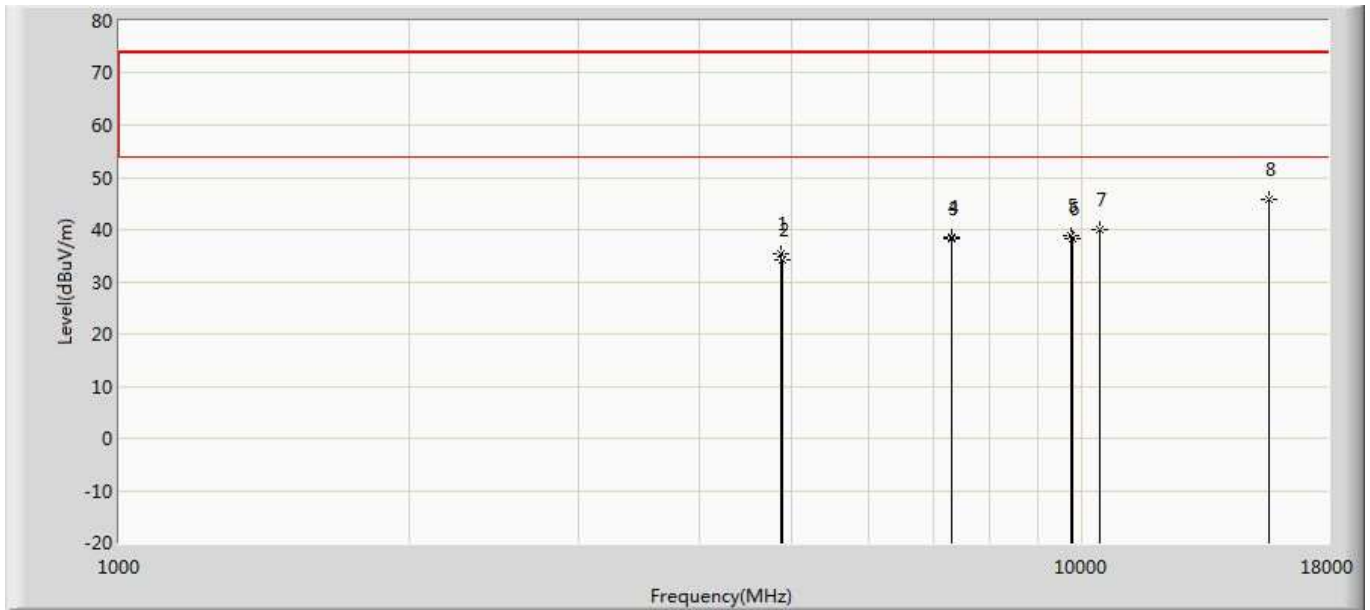

No	Mark	Frequency (MHz)	Measure Level (dBuV/m)	Reading Level (dBuV)	Over Limit (dB)	Limit (dBuV/m)	Factor (dB)	Type
1		4874.000	35.365	31.772	-38.635	74.000	3.593	PK
2		4880.000	34.272	30.682	-39.728	74.000	3.590	PK
3		7311.000	38.392	30.041	-35.608	74.000	8.351	PK
4		7320.000	38.540	30.132	-35.460	74.000	8.408	PK
5		9748.000	38.800	29.859	-35.200	74.000	8.941	PK
6		9760.000	38.262	29.322	-35.738	74.000	8.941	PK
7		10440.000	39.856	28.742	-34.144	74.000	11.114	PK
8	*	15660.000	45.662	28.529	-28.338	74.000	17.133	PK

5. Emissions in non-restricted frequency bands

5.1. Test Equipment

Emissions in non-restricted frequency bands / TR-8					
Instrument	Manufacturer	Type No.	Serial No.	Cal. Date	Cal. Due Date
Spectrum Analyzer	Agilent	N9010A	MY48030494	2019.09.28	2020.09.27
EXA Spectrum Analyzer	Keysight	N9010A	MY55370495	2020.04.17	2021.04.16
MXA Signal Analyzer	Keysight	N9020A	MY56060147	2019.08.30	2020.08.29
Temperature/Humidity Meter	Zhichen	ZC1-2	TR8-TH	2019.09.02	2020.09.01

Note: All equipment is calibrated with traceable calibrations. Each calibration is traceable to the national or international standards.

5.2. Test Setup

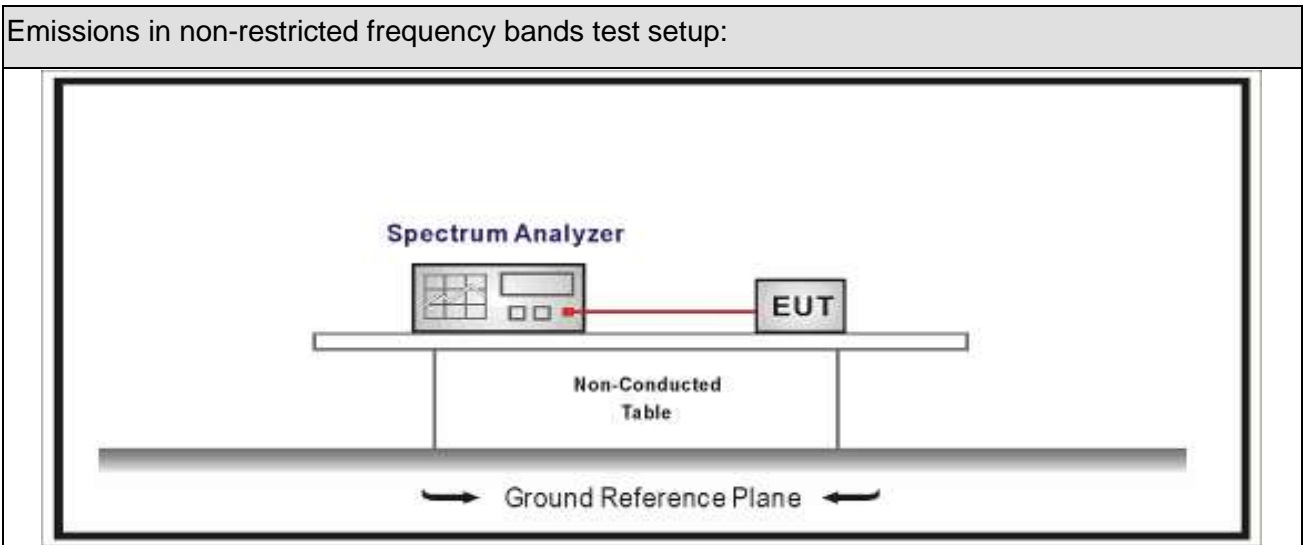





5.3. Limit

Un-Restricted Band Emissions Limit	
RF Output power (Detection methods)	Limit(dB)
RF Output power(Average detector)	30c(Note1)
RF Output power(PK detector)	20c(Note2)
<p>Note 1: If maximum conducted (average) output power was used to demonstrate compliance as described in 9.2, then the peak power in any 100 kHz bandwidth outside of the authorized frequency band shall be attenuated by at least 30 dB relative to the maximum in-band peak PSD level in 100 kHz (i.e., 30 dBc).</p> <p>Note 2: If the maximum peak conducted output power procedure was used, then the peak output power measured in any 100 kHz bandwidth outside of the authorized frequency band shall be attenuated by at least 20 dB relative to the maximum in-band peak PSD level in 100 kHz (i.e., 20 dBc).</p>	

5.4. Test Procedure

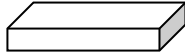
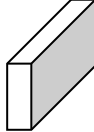
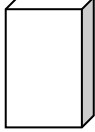
Test Method			
	References Rule	Chapter	Description
<input checked="" type="checkbox"/>	ANSI C63.10	11.11	Emissions in non-restricted frequency bands
	<input checked="" type="checkbox"/> ANSI C63.10	11.11.2	Reference level measurement
	<input checked="" type="checkbox"/> ANSI C63.10	11.11.3	Emission level measurement
<input type="checkbox"/>	ANSI C63.10	11.12	Emissions in restricted frequency bands
	<input type="checkbox"/> ANSI C63.10	11.12.1	Radiated emission measurements
	<input type="checkbox"/> ANSI C63.10	11.12.2.7	Radiated spurious emission test
<input type="checkbox"/>	ANSI C63.10	6.4	Radiated emissions from unlicensed wireless devices below 30 MHz
<input type="checkbox"/>	ANSI C63.10	6.5	Radiated emissions from unlicensed wireless devices in the frequency range of 30 MHz to 1000 MHz
<input type="checkbox"/>	ANSI C63.10	6.6	Radiated emissions from unlicensed wireless devices above 1 GHz
	<input checked="" type="checkbox"/> ANSI C63.10	11.12.2	Antenna-port conducted measurements
	<input type="checkbox"/> ANSI C63.10	11.12.2.3	Quasi-peak measurement procedure
	<input checked="" type="checkbox"/> ANSI C63.10	11.12.2.4	Peak power measurement procedure
	<input type="checkbox"/> ANSI C63.10	11.12.2.5	Average power measurement procedures
	<input type="checkbox"/> ANSI C63.10	11.12.2.5.1	Trace averaging with continuous EUT transmission at full power
	<input type="checkbox"/> ANSI C63.10	11.12.2.5.2	Trace averaging across ON and OFF times of the EUT transmissions followed by duty cycle correction
	<input type="checkbox"/> ANSI C63.10	11.12.2.5.3	Reduced VBW averaging across ON and OFF times of the EUT transmissions with max hold

5.5. EUT test Axis definition

Item	Emissions in non-restricted frequency bands			
Device Category	<input type="checkbox"/>	Fixed point-to-point		
	<input type="checkbox"/>	Emit multiple directional beams, simultaneously or sequentially		
	<input checked="" type="checkbox"/>	Other cases		
Test mode	Mode 1			
Test method	<input type="checkbox"/>	Radiated		
		X Axis	Y Axis	Z Axis
				
		Worst Axis <input type="checkbox"/>	Worst Axis <input type="checkbox"/>	Worst Axis <input type="checkbox"/>
	<input checked="" type="checkbox"/>	Conducted		
	<input checked="" type="checkbox"/>	Chain 1		
				
	<input type="checkbox"/>	Chain 1	Chain 2	
				
	<input type="checkbox"/>	Chain 1	Chain 2	Chain 3
				

5.6. Test Result

Product Name	: Wireless Access Point	Power	: AC 120V/60Hz
Test Mode	: Mode 1	Test Site	: TR-8

Mode	Channel	Test Frequency (MHz)	In-Band PSD[a] (dBm/100kHz)	Frequency (MHz)	Out-Band PSD[b] (dBm/100kHz)	[a]-[b] (dB)	Limit (dB)	Result
1	00	2402	4.023	2400	-42.7	46.723	>30	Pass
1	39	2480	4.062	2575.997	-53.282	57.344	>30	Pass

Note: The worst case of Emissions in non-restricted frequency bands as below:

Mode 1 CH00 (2402MHz)



6. Band Edge

6.1. Test Equipment

Band Edge / TR-8					
Instrument	Manufacturer	Type No.	Serial No.	Cal. Date	Cal. Due Date
Spectrum Analyzer	Agilent	N9010A	MY48030494	2019.09.28	2020.09.27
EXA Spectrum Analyzer	Keysight	N9010A	MY55370495	2020.04.17	2021.04.16
MXA Signal Analyzer	Keysight	N9020A	MY56060147	2019.08.30	2020.08.29
Temperature/Humidity Meter	Zhichen	ZC1-2	TR8-TH	2019.09.02	2020.09.01
Note: All equipment is calibrated with traceable calibrations. Each calibration is traceable to the national or international standards.					

6.2. Test Setup

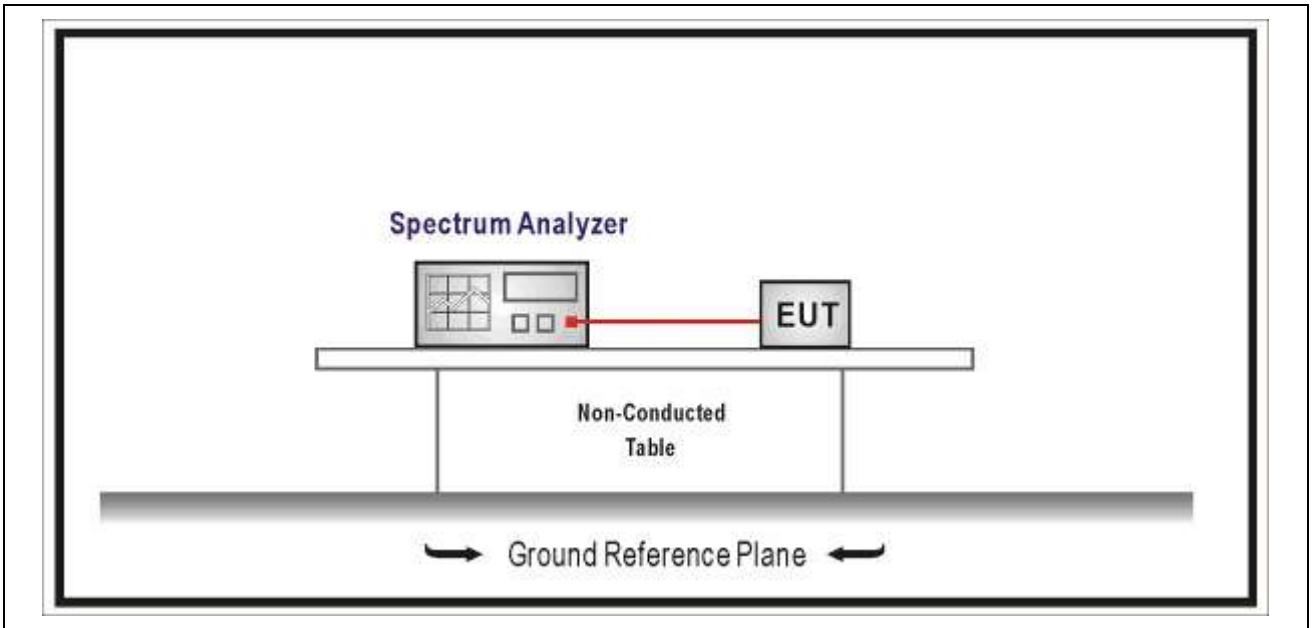

6.3. Limit





Band edge Limit				
Frequency bands (MHz)	Detector	Limit (dB μ V/m)	RBW (MHz)	Distance (m)
2310-2390	PK	74	1	3
2483.5-2500	AV	54	1	3

Note: The field strength of emissions appearing within these frequency bands shall not exceed the limits.

6.4. Test Procedure

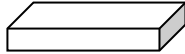
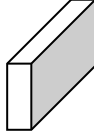
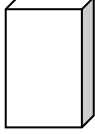
Test Method			
	References Rule	Chapter	Description
<input checked="" type="checkbox"/>	ANSI C63.10	6.10	Band-edge testing
	<input checked="" type="checkbox"/> ANSI C63.10	6.10.5	Restricted-band band-edge measurements
	<input type="checkbox"/> ANSI C63.10	6.10.6	Marker-delta method
<input type="checkbox"/>	ANSI C63.10	11.12	Emissions in restricted frequency bands
	<input type="checkbox"/> ANSI C63.10	11.12.1	Radiated emission measurements
	<input type="checkbox"/> ANSI C63.10	11.12.2.7	Radiated spurious emission test
<input type="checkbox"/>	ANSI C63.10	6.4	Radiated emissions from unlicensed wireless devices below 30 MHz
<input type="checkbox"/>	ANSI C63.10	6.5	Radiated emissions from unlicensed wireless devices in the frequency range of 30 MHz to 1000 MHz
<input type="checkbox"/>	ANSI C63.10	6.6	Radiated emissions from unlicensed wireless devices above 1 GHz
	<input checked="" type="checkbox"/> ANSI C63.10	11.12.2	Antenna-port conducted measurements
	<input type="checkbox"/> ANSI C63.10	11.12.2.3	Quasi-peak measurement procedure
	<input checked="" type="checkbox"/> ANSI C63.10	11.12.2.4	Peak power measurement procedure
	<input checked="" type="checkbox"/> ANSI C63.10	11.12.2.5	Average power measurement procedures
	<input type="checkbox"/> ANSI C63.10	11.12.2.5.1	Trace averaging with continuous EUT transmission at full power
	<input type="checkbox"/> ANSI C63.10	11.12.2.5.2	Trace averaging across ON and OFF times of the EUT transmissions followed by duty cycle correction
	<input checked="" type="checkbox"/> ANSI C63.10	11.12.2.5.3	Reduced VBW averaging across ON and OFF times of the EUT transmissions with max hold

6.5. EUT test definition

Item	Radiated Emission Band Edge			
Device Category	<input type="checkbox"/>	Fixed point-to-point		
	<input type="checkbox"/>	Emit multiple directional beams, simultaneously or sequentially		
	<input checked="" type="checkbox"/>	Other cases		
Test mode	Mode 1			
Test method	<input type="checkbox"/>	Radiated		
		X Axis	Y Axis	Z Axis
				
		Worst Axis <input type="checkbox"/>	Worst Axis <input type="checkbox"/>	Worst Axis <input type="checkbox"/>
	<input checked="" type="checkbox"/>	Conducted		
	<input checked="" type="checkbox"/>	Chain 1		
				
	<input type="checkbox"/>	Chain 1	Chain 2	
				
	<input type="checkbox"/>	Chain 1	Chain 2	Chain 3
				

6.6. Duty Cycle

Test Mode	Tx On (ms)	Tx Off (ms)	Reduced VBW	Tx On + Tx Off (ms)	Duty Cycle
BLE	0.392	0.232	3kHz	0.624	62.82%

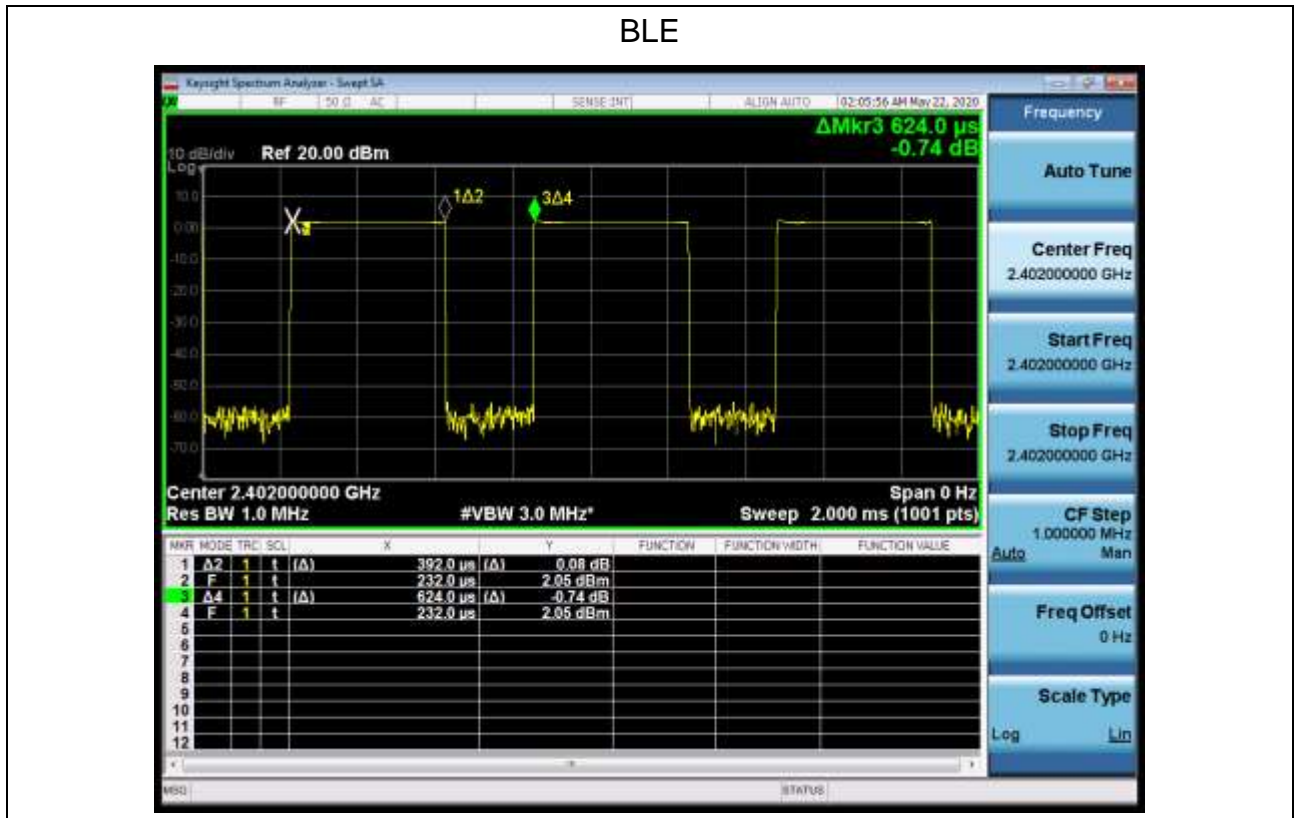

6.7 Test Result

PK Limit=74dBuV/m-95.2-7.9(Antenna Gain) =-29.1dBm

AV Limit=54dBuV/m-95.2-7.9(Antenna Gain) =-49.1dBm

2402MHz

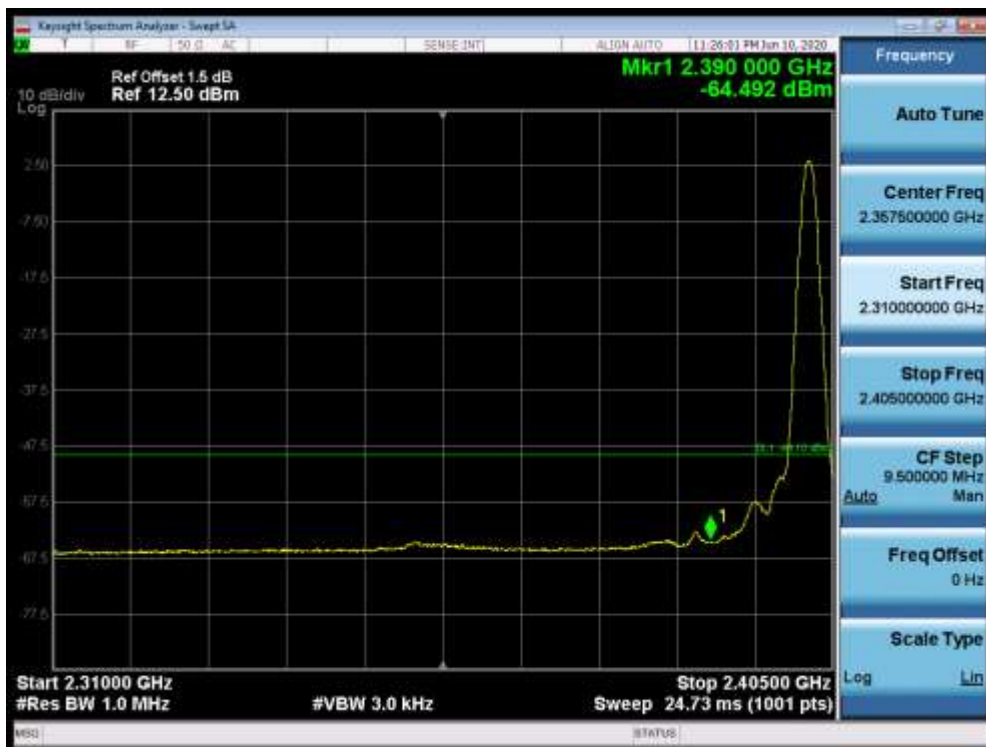

2480MHz

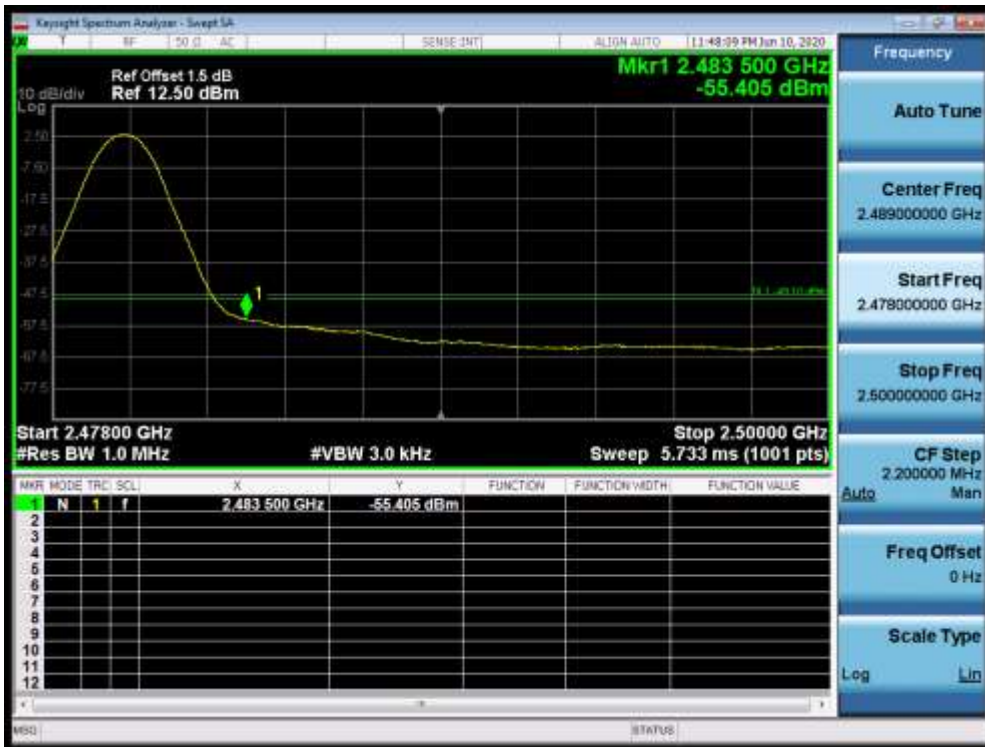
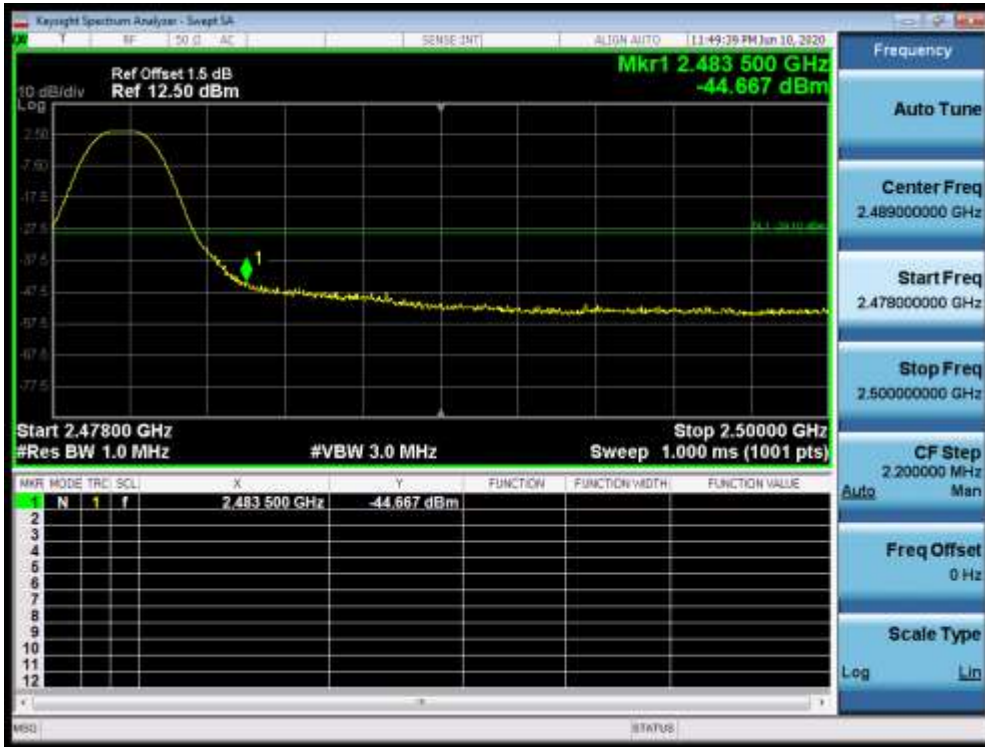

7. Occupied Bandwidth

7.1. Test Equipment

Occupied Bandwidth / TR-8					
Instrument	Manufacturer	Type No.	Serial No.	Cal. Date	Cal. Due Date
Spectrum Analyzer	Agilent	N9010A	MY48030494	2019.09.28	2020.09.27
EXA Spectrum Analyzer	Keysight	N9010A	MY55370495	2020.04.17	2021.04.16
MXA Signal Analyzer	Keysight	N9020A	MY56060147	2019.08.30	2020.08.29
Temperature/Humidity Meter	Zhichen	ZC1-2	TR8-TH	2019.09.02	2020.09.01

Note: All equipment is calibrated with traceable calibrations. Each calibration is traceable to the national or international standards.

7.2. Test Setup

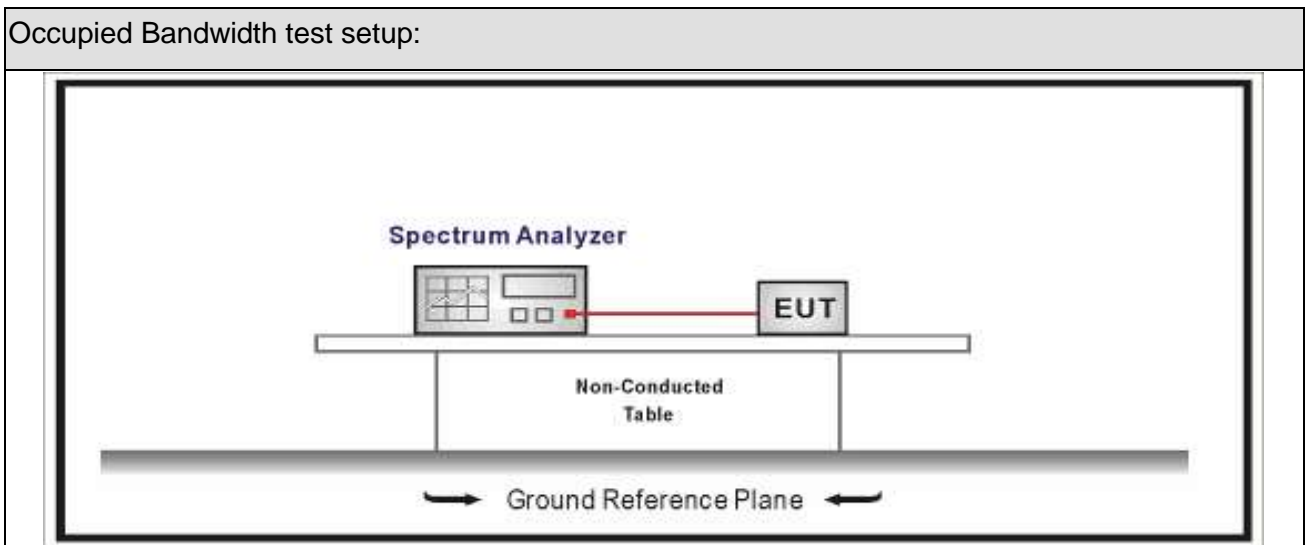



7.3. Limit

Occupied Bandwidth
Systems using digital modulation techniques operate in the 2400-2483.5 MHz .The minimum 6 dB bandwidth shall be at least 500 kHz

7.4. Test Procedure

Test Method			
	Reference Rule	Chapter	Description
<input checked="" type="checkbox"/>	ANSI C63.10	11.8	DTS bandwidth
<input type="checkbox"/>	ANSI C63.10	11.8.1	Option 1
<input checked="" type="checkbox"/>	ANSI C63.10	11.8.2	Option 2

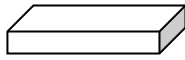
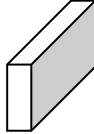
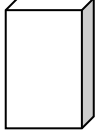
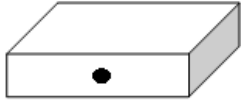
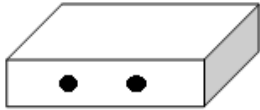
7.5. EUT test definition

Item	Occupied Bandwidth			
Device Category	<input type="checkbox"/>	Fixed point-to-point		
	<input type="checkbox"/>	Emit multiple directional beams, simultaneously or sequentially		
	<input checked="" type="checkbox"/>	Other cases		
Test mode	Mode 1			
Test method	<input type="checkbox"/>	Radiated		
		X Axis	Y Axis	Z Axis
				
		Worst Axis <input type="checkbox"/>	Worst Axis <input type="checkbox"/>	Worst Axis <input type="checkbox"/>
	<input checked="" type="checkbox"/>	Conducted		
	<input checked="" type="checkbox"/>	Chain 1		
				
	<input type="checkbox"/>	Chain 1	Chain 2	
				
	<input type="checkbox"/>	Chain 1	Chain 2	Chain 3
				

7.6. Test Result

Product Name	: Wireless Access Point	Power	: AC 120V/60Hz
Test Mode	: Mode 1	Test Site	: TR-8

Mode	CH.	Test Freq. (MHz)	99% Occupied Bandwidth (kHz)	6dB Occupied Bandwidth (kHz)	Limit (kHz)	Result
1	00	2402	1055.5	666.9	>500	Pass
1	19	2440	1052.0	669.5	>500	Pass
1	39	2480	1053.3	670.8	>500	Pass

Note : The worst case of Occupied Bandwidth as below:

Mode 1 CH00 (2402MHz) for 6dB Bandwidth



Mode 1 CH19 (2440MHz) for 99% Bandwidth

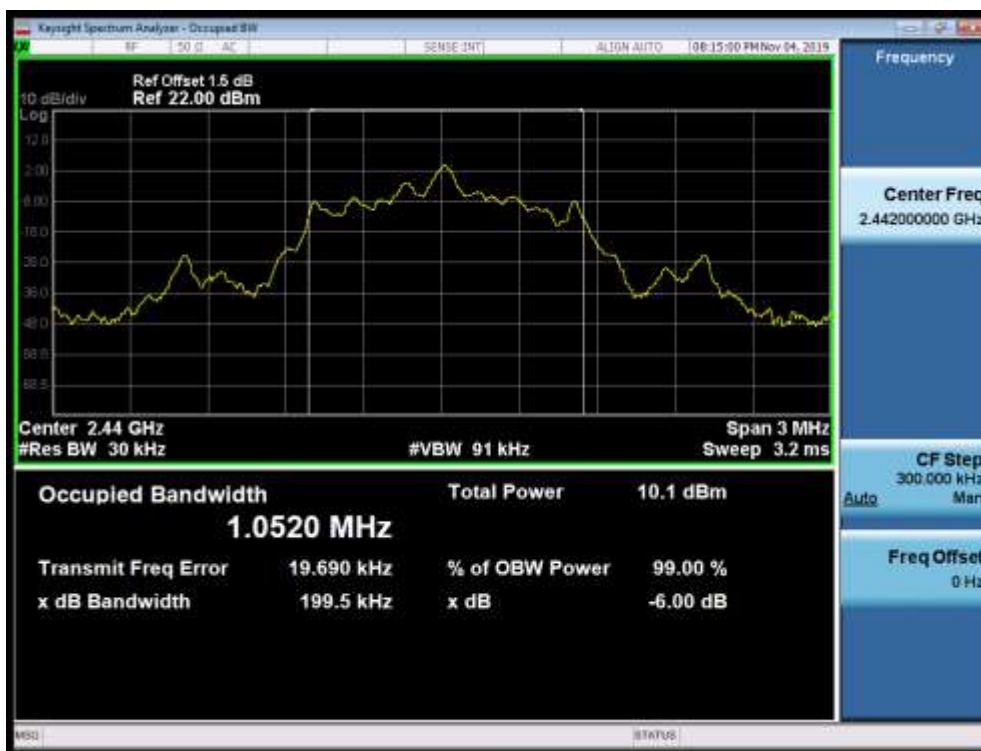

8. Fundamental emission output power

8.1. Test Equipment

Fundamental Emission output power / TR-8					
Instrument	Manufacturer	Type No.	Serial No.	Cal. Date	Cal. Due Date
Spectrum Analyzer	Agilent	N9010A	MY48030494	2019.09.28	2020.09.27
EXA Spectrum Analyzer	Keysight	N9010A	MY55370495	2020.04.17	2021.04.16
MXA Signal Analyzer	Keysight	N9020A	MY56060147	2019.08.30	2020.08.29
Wideband Peak Power Meter	Anritsu	ML2495A	1613005	2019.10.28	2020.10.27
Power Sensor	Anritsu	MA2411B	1531092	2019.10.14	2020.10.13
Temperature/Humidity Meter	Zhichen	ZC1-2	TR8-TH	2019.09.02	2020.09.01

Note: All equipment is calibrated with traceable calibrations. Each calibration is traceable to the national or international standards.

8.2. Test Setup

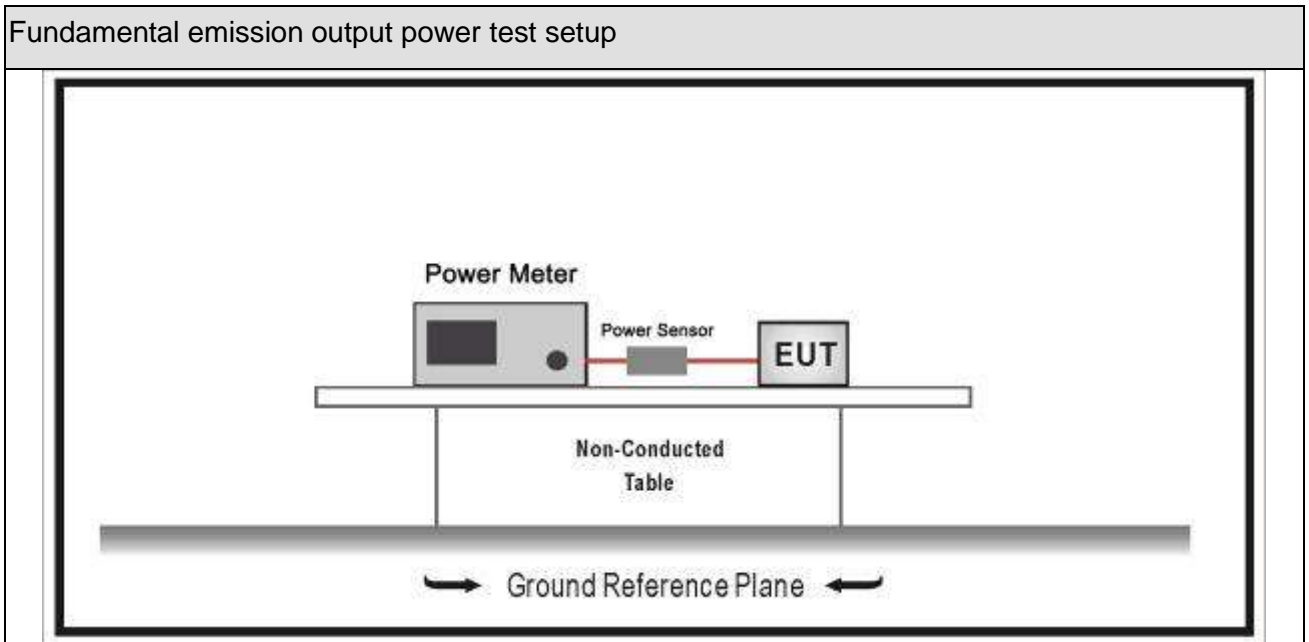



8.3. Limit

Fundamental emission output power Limit		
<input type="checkbox"/>	$G_{TX} < 6\text{dBi}$	$P_{out} \leq 30\text{dBm}$
<input checked="" type="checkbox"/>	$G_{TX} > 6\text{dBi}$	
	<input checked="" type="checkbox"/> Non-Fix point-point	$P_{out} \leq 30 - (G_{TX} - 6)$
	<input type="checkbox"/> Fix point-point	$P_{out} \leq 30 - [(G_{TX} - 6)]/3$
	<input type="checkbox"/> Point-to-multipoint	$P_{out} \leq 30 - (G_{TX} - 6)$
	<input type="checkbox"/> Overlap Beams	$P_{out} \leq 30 - [(G_{TX} - 6)]/3$
	<input type="checkbox"/> Aggregate power transmitted simultaneously on all beams	$P_{out} \leq 30 - [(G_{TX} - 6)]/3$
	<input type="checkbox"/> single directional beam	$P_{out} \leq 30 - [(G_{TX} - 6)]/3 + 8\text{dB}$
Note 1 : G_{TX} directional gain of transmitting antennas.		
Note 2 : P_{out} is maximum peak conducted output power .		

8.4. Test Procedure

Fundamental emission output power Test Method						
	References Rule		Chapter	Description		
<input checked="" type="checkbox"/>	ANSI C63.10		11.9	Fundamental emission output power		
	<input type="checkbox"/>	ANSI C63.10		11.9.1	Maximum peak conducted output power	
		<input type="checkbox"/>	ANSI C63.10	11.9.1.1	RBW ≥ DTS bandwidth	
		<input type="checkbox"/>	ANSI C63.10	11.9.1.2	Integrated band power method	
		<input type="checkbox"/>	ANSI C63.10	11.9.1.3	PKPM1 Peak power meter method	
	<input checked="" type="checkbox"/>	ANSI C63.10		11.9.2	Maximum conducted (average) output power	
		<input type="checkbox"/>	ANSI C63.10		11.9.2.2	Measurement using a spectrum analyzer (SA)
			<input type="checkbox"/>	ANSI C63.10	11.9.2.2.2	Method AVGSA-1(Duty cycle ≥ 98%)
			<input type="checkbox"/>	ANSI C63.10	11.9.2.2.3	Method AVGSA-1A(Duty cycle ≥ 98%)
			<input type="checkbox"/>	ANSI C63.10	11.9.2.2.4	Method AVGSA-2(Duty cycle ≤ 98%)
			<input type="checkbox"/>	ANSI C63.10	11.9.2.2.5	Method AVGSA-2A(Duty cycle ≤ 98%)
			<input type="checkbox"/>	ANSI C63.10	11.9.2.2.4	Method AVGSA-3
			<input type="checkbox"/>	ANSI C63.10	11.9.2.2.5	Method AVGSA-3A
		<input checked="" type="checkbox"/>	ANSI C63.10		11.9.2.3	Measurement using a power meter (PM)
		<input type="checkbox"/>	ANSI C63.10	11.9.2.3.1	Method AVGPM	
<input checked="" type="checkbox"/>		ANSI C63.10	11.9.2.3.2	Method AVGPM-G		

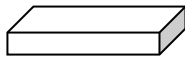
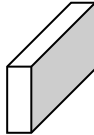
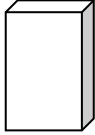
8.5. EUT test definition

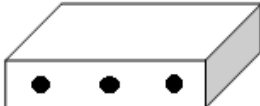
Item	Fundamental emission output power			
Device Category	<input type="checkbox"/>	Fixed point-to-point		
	<input type="checkbox"/>	Emit multiple directional beams, simultaneously or sequentially		
	<input checked="" type="checkbox"/>	Other cases		
Test mode	Mode 1			
Test method	<input type="checkbox"/>	Radiated		
		X Axis	Y Axis	Z Axis
				
		Worst Axis <input type="checkbox"/>	Worst Axis <input type="checkbox"/>	Worst Axis <input type="checkbox"/>
	<input checked="" type="checkbox"/>	Conducted		
	<input checked="" type="checkbox"/>	Chain 1		
				
	<input type="checkbox"/>	Chain 1	Chain 2	
				
	<input type="checkbox"/>	Chain 1	Chain 2	Chain 3
				

8.6. Test Result

Product Name	:	Wireless Access Point	Power	:	AC 120V/60Hz
Test Mode	:	Mode 1	Test Site	:	TR-8

Mode	Channel	Test Frequency (MHz)	Conducted Power (dBm)	EIRP (dBm)	Conducted Power Limit (dBm)	EIRP Limit (dBm)	Result
1	00	2402	3.92	11.82	28.1	36	Pass
1	19	2440	3.74	11.64	28.1	36	Pass
1	39	2480	3.81	11.71	28.1	36	Pass

9. Power Spectral Density

9.1. Test Equipment

Power Spectral Density / TR-8					
Instrument	Manufacturer	Type No.	Serial No.	Cal. Date	Cal. Due Date
Spectrum Analyzer	Agilent	N9010A	MY48030494	2019.09.28	2020.09.27
EXA Spectrum Analyzer	Keysight	N9010A	MY55370495	2020.04.17	2021.04.16
MXA Signal Analyzer	Keysight	N9020A	MY56060147	2019.08.30	2020.08.29
Temperature/Humidity Meter	Zhichen	ZC1-2	TR8-TH	2019.09.02	2020.09.01

Note: All equipment is calibrated with traceable calibrations. Each calibration is traceable to the national or international standards.

9.2. Test Setup

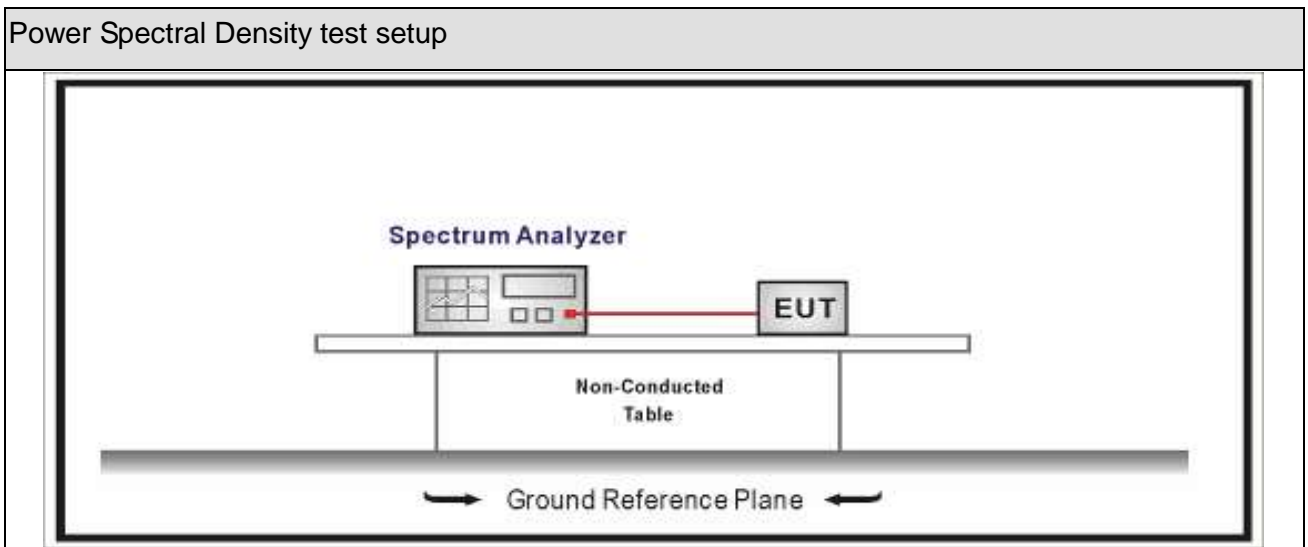

9.3. Limit

Power Spectral Density Limit
Power Spectral Density $\leq 8\text{dBm}/3\text{kHz}$

9.4. Test Procedure

Power Spectral Density Test Method			
	References Rule	Chapter	Description
<input checked="" type="checkbox"/>	ANSI C63.10	11.10	Maximum power spectral density level in the fundamental emission
<input checked="" type="checkbox"/>	ANSI C63.10	11.10.2	Method PKPSD (peak PSD)
<input type="checkbox"/>	ANSI C63.10	11.10.3	Method AVGPSD-1(Duty cycle \geq 98%)
<input type="checkbox"/>	ANSI C63.10	11.10.4	Method AVGPSD-1A(Duty cycle \geq 98%)
<input type="checkbox"/>	ANSI C63.10	11.10.5	Method AVGPSD-2(Duty cycle $<$ 98%)
<input type="checkbox"/>	ANSI C63.10	11.10.6	Method AVGPSD-2A(Duty cycle $<$ 98%)
<input type="checkbox"/>	ANSI C63.10	11.10.7	Method AVGPSD-3
<input type="checkbox"/>	ANSI C63.10	11.10.8	Method AVGPSD-3A

9.5. EUT test definition

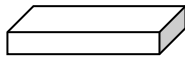
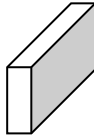
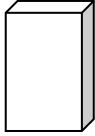
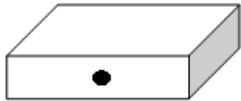
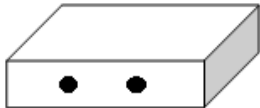
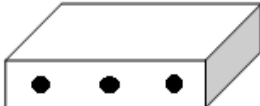
Item	Power Spectral Density Test Method			
Device Category	<input type="checkbox"/>	Fixed point-to-point		
	<input type="checkbox"/>	Emit multiple directional beams, simultaneously or sequentially		
	<input checked="" type="checkbox"/>	Other cases		
Test mode	Mode 1			
Test method	<input type="checkbox"/>	Radiated		
		X Axis	Y Axis	Z Axis
				
		Worst Axis <input type="checkbox"/>	Worst Axis <input type="checkbox"/>	Worst Axis <input type="checkbox"/>
	<input checked="" type="checkbox"/>	Conducted		
	<input checked="" type="checkbox"/>	Chain 1		
				
	<input type="checkbox"/>	Chain 1	Chain 2	
				
	<input type="checkbox"/>	Chain 1	Chain 2	Chain 3
				

9.6. Test Result

Product Name	: Wireless Access Point	Power	: AC 120V/60Hz
Test Mode	: Mode 1	Test Site	: TR-8

Mode	Channel	Test Frequency (MHz)	Measurement PSD (dBm/3kHz)	Total PSD (dBm/3kHz)	Limit (dBm/3kHz)	Result
1	00	2402	2.617	2.617	8	Pass
1	19	2440	2.835	2.835	8	Pass
1	39	2480	2.563	2.563	8	Pass

Note : The worst case of Power Spectral Density as below:

Mode 1 CH19(2440MHz)

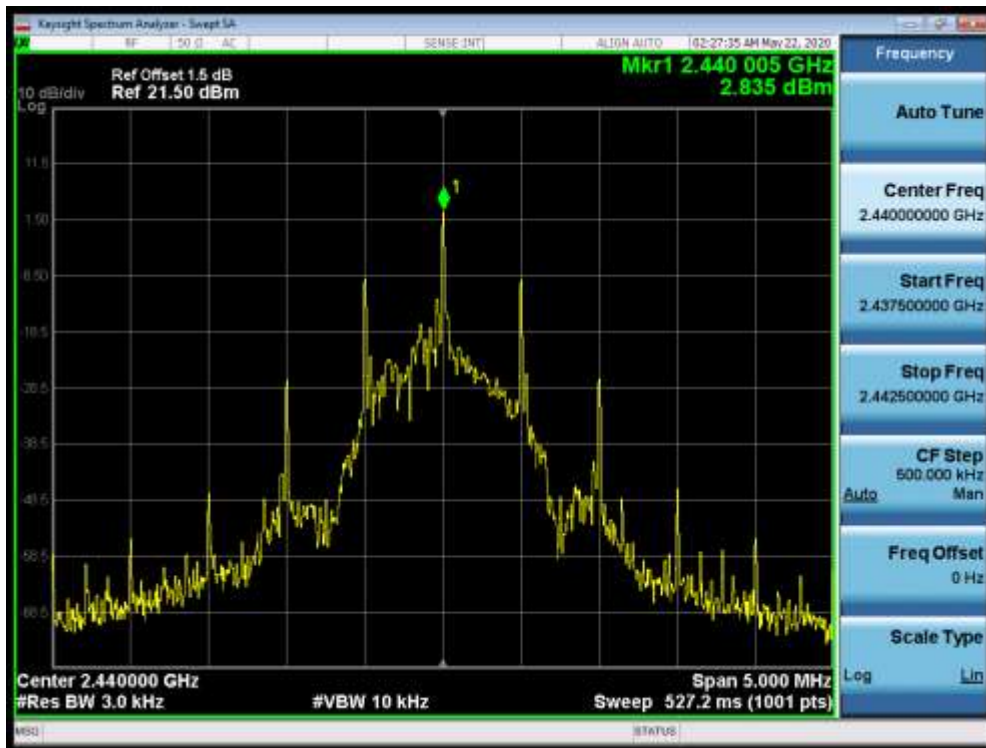

10. Antenna Requirement

10.1. Limit

Antenna Requirement Limit
<p>An intentional radiator shall be designed to ensure that no antenna other than that furnished by the responsible party shall be used with the device. The use of a permanently attached antenna or of an antenna that uses a unique coupling to the intentional radiator shall be considered sufficient to comply with the provisions of this section. The manufacturer may design the unit so that a broken antenna can be replaced by the user, but the use of a standard antenna jack or electrical connector is prohibited. This requirement does not apply to carrier current devices or to devices operated under the provisions of §15.211, §15.213, §15.217, §15.219, or §15.221. Further, this requirement does not apply to intentional radiators that must be professionally installed, such as perimeter protection systems and some field disturbance sensors, or to other intentional radiators which, in accordance with §15.31(d), must be measured at the installation site. However, the installer shall be responsible for ensuring that the proper antenna is employed so that the limits in this part are not exceeded.</p>

10.2. Antenna Connector Construction

Antenna Connector Construction	
<input type="checkbox"/>	The use of a permanently attached antenna
<input type="checkbox"/>	The antenna use of a unique coupling to the intentional radiator
<input checked="" type="checkbox"/>	The use of a nonstandard antenna jack or electrical connector
Please refer to the attached document "Internal Photograph" to show the antenna connector.	

_____ The End _____