



FCC

RF Test Report

Product Name: HUAWEI MediaPad M1 8.0

Model Number: S8-302L

Report No: SYBH(Z-RF)024052014-2004

FCC ID: QISS8-302L

Reliability Laboratory of Huawei Technologies Co., Ltd.

Administration Building, Headquarters of Huawei Technologies Co., Ltd., Bantian, Longgang District,
Shenzhen, 518129, P.R.C

Tel: +86 755 28780808

Fax: +86 755 89652518



Notice

1. The laboratory has Passed the accreditation by China National Accreditation Service for Conformity Assessment (CNAS). The accreditation number is L0310.
2. The laboratory has Passed the accreditation by The American Association for Laboratory Accreditation (A2LA). The accreditation number is 2174.01.
3. The laboratory has been listed by the US Federal Communications Commission to perform electromagnetic emission measurements. The site recognition number is 97456.
4. The laboratory has been listed by Industry Canada to perform electromagnetic emission measurements. The recognition numbers of test site are 6369A-1 and 6369A-3.
5. The test report is invalid if not marked with the signatures of the persons responsible for preparing and approving the test report.
6. The test report is invalid if there is any evidence of erasure and/or falsification.
7. The test report is only valid for the test samples.
8. Content of the test report, in part or in full, cannot be used for publicity and/or promotional purposes without prior written approval from the laboratory.



Applicant: Huawei Technologies Co., Ltd.
Address: Administration Building, Headquarters of Huawei Technologies Co., Ltd.,
Bantian, Longgang District, Shenzhen, 518129, P.R.C

Date of Receipt Sample: 2014-05-27
Start Date of Test: 2014-05-28
End Date of Test: 2014-06-18

Test Result: Pass

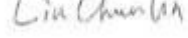
| | | | |
|-------------------------------------|------------|-------------|---|
| Approved by Senior Engineer: | 2014-06-27 | Liu Chunlin |  |
| | Date | Name | Signature |

| | | | |
|---------------------|------------|--------------|---|
| Prepared by: | 2014-06-27 | Zhang Guocai |  |
| | Date | Name | Signature |



Modification Record

| No. | Last Report No. | Modification Description |
|-----|-----------------|--------------------------|
| | | First Report |
| | | |
| | | |
| | | |



CONTENT

1 General Information.....6

1.1 Applied Standard.....6

1.2 Test Location6

1.3 Test Environment Condition.....6

2 Test Summary7

3 Description of the Equipment under Test (EUT)8

3.1 General Description8

3.2 EUT Identity8

3.3 Technical Description.....9

4 General Test Conditions / Configurations 10

4.1 Test Modes 10

4.2 EUT Configurations..... 10

4.3 Test Environments 11

4.4 Antenna requirements..... 11

4.5 Description of tests..... 12

4.6 Test Setups..... 14

4.7 Test Conditions 17

5 Main Test Instruments 18



1 General Information

1.1 **Applied Standard**

Applied Rules: 47 CFR FCC Part 2, Subpart J 2013
47 CFR FCC Part 15, Subpart C 2013

Test Method: FCC KDB 558074 D01 DTS Meas Guidance v03r01
ANSI C63.10-2009, American National Standard for Testing Unlicensed
Wireless Devices.

1.2 **Test Location**

Test Location 1: Reliability Laboratory of Huawei Technologies Co., Ltd.
Address: Administration Building, Headquarters of Huawei Technologies Co., Ltd.,
Bantian, Longgang District, Shenzhen, 518129, P.R.C

1.3 **Test Environment Condition**

Ambient Temperature: 19.5to 25 °C
Ambient Relative Humidity: 40 to 55 %
Atmospheric Pressure: Not applicable



2 Test Summary

| Test Item | FCC Part No. | Requirements | Test Result | Verdict |
|--|---------------------------------|--|-------------|---------|
| DTS (6 dB) Bandwidth | 15.247(a)(2) | ≥ 500 kHz. | Appendix A | Pass |
| Maximum Peak Conducted Output Power | 15.247(b)(3) | For directional gain: < 30 dBm – (G[dBi] – 6 [dB]), peak; Otherwise: < 30 dBm, peak. | Appendix B | Pass |
| Maximum Power Spectral Density Level | 15.247(e) | For directional gain: < 8 dBm/3 kHz – (G[dBi] – 6 [dB]), peak. Otherwise: < 8 dBm/3 kHz, peak. | Appendix C | Pass |
| Band Edges Compliance | 15.247(d) | < -20 dBm/100 kHz if total peak power \leq power limit. | Appendix D | Pass |
| Unwanted Emissions into Non-Restricted Frequency Bands | | | Appendix E | Pass |
| Unwanted Emissions into Restricted Frequency Bands (Radiated) | 15.247(d) 15.209 (NOTE 1) | FCC Part 15.209 field strength limit; | NOTE 2 | Pass |
| AC Power Line Conducted Emissions | 15.207 | FCC Part 15.207 conducted limit; | Appendix F | Pass |
| <p>NOTE 1: According to KDB 558074, antenna-port conducted measurements are acceptable as an alternative to radiated measurements for demonstrating compliance to the limits in the restricted frequency bands. If conducted measurements are performed, then proper impedance matching must be ensured and an additional radiated test for cabinet/case emissions will also be required.</p> <p>NOTE 2: The Unwanted Emissions into Restricted Frequency Bands (Radiated) tested by Neutron Engineering Inc. So the test data refer to the report No. NEI-FCCP-1-1402C116 by Neutron Engineering Inc.</p> | | | | |

3 Description of the Equipment under Test (EUT)

3.1 General Description

HUAWEI MediaPad M1 8.0 (MediaPad M1 for short) is a 8 inch tablet that incorporates Hislicon processor With support for 3G,LTE and WI-FI and BT data connections, MediaPad M1 provides users with unprecedented access to high-speed internet services.

3.2 EUT Identity

NOTE: Unless otherwise noted in the report, the functional boards installed in the units shall be selected from the below list, but not means all the functional boards listed below shall be installed in one unit.

3.2.1 Board

| Board | | |
|---------------------|------------------|-------------|
| Software Version | Hardware Version | Description |
| S8-302LV100R001C001 | SH1S8301LM | Main Board |

3.2.1 Sub-Assembly

| Sub-Assembly | | | |
|-------------------|--------------|------------------------------|--|
| Sub-Assembly Name | Model | Manufacturer | Description |
| Adapter | HW-050200E3W | Huawei Technologies Co.,Ltd. | Input voltage: 100V~240V AC and 50/60 Hz,0.5A Output voltage: +5V $\overline{\text{---}}$ 2A |
| Adapter | HW-050200B3W | Huawei Technologies Co.,Ltd. | Input voltage: 100V~240V AC and 50/60 Hz,0.5A Output voltage: +5V $\overline{\text{---}}$ 2A |
| Adapter | HW-050200A3W | Huawei Technologies Co.,Ltd. | Input voltage: 100V~240V AC and 50/60 Hz,0.5A Output voltage: +5V $\overline{\text{---}}$ 2A |
| Adapter | HW-050200U3W | Huawei Technologies Co.,Ltd. | Input voltage: 100V~240V AC and 50/60 Hz,0.5A Output voltage: +5V $\overline{\text{---}}$ 2A |
| Li-ion | HB3080G1EBC | Huawei Technologies Co.,Ltd. | Rated capacity: 4800 mAh Nominal Voltage: $\overline{\text{---}}$ +3.8V Charging Voltage: $\overline{\text{---}}$ +4.35V |

3.3 Technical Description

| Characteristics | Description | | | |
|---------------------------------|--|--|-------------------------------|---------------------------------|
| IEEE 802.11 WLAN Mode Supported | <input checked="" type="checkbox"/> 802.11b (20 MHz channel bandwidth), <input checked="" type="checkbox"/> 802.11g (20 MHz channel bandwidth) <input checked="" type="checkbox"/> 802.11n (20 MHz channel bandwidth) | | | |
| TX/RX Operating Range | 2412-2462 MHz band | $f_c = 2407 \text{ MHz} + N * 5 \text{ MHz}$, where: - f_c = "Operating Frequency" in MHz, - N = "Channel Number" with the range from 1 to 11 for the 20 MHz channel bandwidth, or 3 to 9 for the 40 MHz channel bandwidth. | | |
| Data Rate | 802.11b | 1 Mbps, 2 Mbps, 5.5 Mbps, 11 Mbps | | |
| | 802.11g | 6 Mbps, 9 Mbps, 12 Mbps, 18 Mbps, 24 Mbps, 36 Mbps, 48 Mbps, 54 Mbps | | |
| | 802.11n (SISO) | MCS 0 to MCS 7 | | |
| Modulation Type | DBPSK/DQPSK/CCK (DSSS), BPSK/QPSK/16QAM/64QAM (OFDM). | | | |
| Emission Designator | 9M32G1D (for 802.11b mode), 16M5G7D (for 802.11g mod), 17M7G7D (for 802.11n mode) | | | |
| TX Power Control | <input type="checkbox"/> Supported, <input checked="" type="checkbox"/> Not Supported | | | |
| Standby Mode | <input type="checkbox"/> Supported, <input checked="" type="checkbox"/> Not Supported | | | |
| Equipment Type | <input type="checkbox"/> Stand-alone equipment, <input type="checkbox"/> Plug-in radio device, <input checked="" type="checkbox"/> Combined equipment | | | |
| Antenna | Description | Isotropic Antenna | | |
| | Type | <input type="checkbox"/> External, <input checked="" type="checkbox"/> Integrated | | |
| | Ports | <input checked="" type="checkbox"/> Ant 1, <input type="checkbox"/> Ant 2, <input type="checkbox"/> Ant 3 | | |
| | Smart System | <input checked="" type="checkbox"/> SISO (for 802.11b/g/n), <input type="checkbox"/> MIMO (for 802.11n): 2 Tx & 2 Rx, <input type="checkbox"/> Diversity (for 802.11b/g) : Tx & Rx | | |
| | Gain | 1 dBi (per antenna port, max.) | | |
| | Remark | When the EUT is put into service, the practical maximum antenna gain should NOT exceed the value as described above. | | |
| Power Supply | Type | <input checked="" type="checkbox"/> AC/DC Adapter | <input type="checkbox"/> PoE: | <input type="checkbox"/> Other: |



4 General Test Conditions / Configurations

4.1 Test Modes

NOTE: Worst cases for each IEEE 802.11 mode are selected to perform tests.

| Test Mode | Test Modes Description |
|-----------|--|
| 11B | IEEE 802.11b with data rate of 1 Mbps using SISO mode. |
| 11G | IEEE 802.11g with data rate of 6 Mbps using SISO mode. |
| 11N20 | IEEE 802.11n with data rate of MCS0 and bandwidth of 20 MHz using SISO mode. |

4.2 EUT Configurations

4.2.1 General Configurations

| Configuration | Description |
|---------------------|--|
| Test Antenna Ports | Until otherwise specified, - All TX tests are performed at all TX antenna ports of the EUT, and - All RX tests are performed at all RX antenna ports of the EUT. |
| Multiple RF Sources | Other than the tested RF source of the EUT, other RF source(s) are disabled or shutdown during measurements. |

4.2.2 Customized Configurations

| Test Mode | RF Ch. | Antenna Port | TX Freq. [MHz] | RX Freq. [MHz] | Ch. BW [MHz] | Power Conf., per Port |
|-----------|--------|--------------|----------------------|----------------|--------------|-----------------------|
| 11B | L | Ant 1 | Ch No. 1 / 2412 MHz | --- | 20 | 14 |
| 11B | M | Ant 1 | Ch No. 6 / 2437 MHz | --- | 20 | 14 |
| 11B | H | Ant 1 | Ch No. 11 / 2462 MHz | --- | 20 | 14 |
| 11G | L | Ant 1 | Ch No. 1 / 2412 MHz | --- | 20 | 12 |
| 11G | M | Ant 1 | Ch No. 6 / 2437 MHz | --- | 20 | 12 |
| 11G | H | Ant 1 | Ch No. 11 / 2462 MHz | --- | 20 | 12 |
| 11N20 | L | Ant 1 | Ch No. 1 / 2412 MHz | --- | 20 | 12 |
| 11N20 | M | Ant 1 | Ch No. 6 / 2437 MHz | --- | 20 | 12 |
| 11N20 | H | Ant 1 | Ch No. 11 / 2462 MHz | --- | 20 | 12 |



4.3 Test Environments

NOTE: The values used in the test report may be stringent than the declared.

| Environment Parameter | Selected Values During Tests | | |
|-----------------------|------------------------------|---------|-------------------|
| | Temperature | Voltage | Relative Humidity |
| NTNV | Ambient | 3.8 VDC | Ambient |

4.4 Antenna requirements

Excerpt from §15.203 of the FCC Rules/Regulations:

“An intentional radiator antenna shall be designed to ensure that no antenna other than that furnished by the responsible party can be used with the device. The use of a permanently attached antenna or of an antenna that uses a unique coupling to the intentional radiator shall be considered sufficient to comply with the provisions of this section.”

The antennas of the **EUT** are **permanently attached**.

There are no provisions for connection to an external antenna.

Conclusion:

The **EUT FCC ID: QISS8-302L** unit complies with the requirement of §15.203.

Ch. Frequency (MHz)

| Ch. | Frequency (MHz) |
|-----------|-----------------|
| 01 | 2412 |
| . | . |
| . | . |
| 06 | 2437 |
| . | . |
| . | . |
| 11 | 2462 |

Frequency/ Channel Operations

4.5 Description of tests

4.5.1 Bandwidth measurement

- (a) Connect EUT test port to spectrum analyzer.
- (b) Set the EUT to transmit maximum output power at 2.4GHz, then set the measured frequency number and test the bandwidth with spectrum analyzer.

4.5.2 Peak output power

- (a) Connect EUT test port to spectrum analyzer.
- (b) Set the EUT to transmit maximum output power at 2.4GHz.
- (c) Then set the EUT to transmit at high, middle and low frequency and measure the conducted output power separately.

4.5.3 Average power

- (a) Connect EUT test port to spectrum analyzer.
- (b) Set the EUT to transmit maximum output power at 2.4GHz.
- (c) Then set the EUT to transmit at high, middle and low frequency and measure the Average power separately.

4.5.4 Band edge spurious emission

- (a) Connect EUT test port to spectrum analyzer
- (b) Set the EUT to transmit maximum output power at 2.4GHz.
- (c) Then set the EUT to transmit at high, low frequency and measure the conducted band edge spurious separately.

4.5.5 Conducted RF spurious

- (a) Connect EUT test port to spectrum analyzer
- (b) Set the EUT to transmit maximum output power at 2.4GHz.
- (c) Then set the EUT to transmit at high, middle and low frequency and measure the conducted spurious separately.

4.5.6 Power spectral density

- (a) Connect EUT test port to spectrum analyzer
- (b) Set the EUT to transmit maximum output power at 2.4GHz.
- (c) Then set the EUT to transmit at high, middle and low frequency and measure the conducted power spectral density.

4.5.7 Radiated spurious emission & spurious in restricted band

The test site semi-anechoic chamber has met the requirement of NSA tolerance 4dB according to the standards: ANSI C63.10 (2009). The EUT was set-up on insulator 80cm above the Ground Plane. The set-up and test methods were according to ANSI C63.10:2009. The Radiated Disturbance measurements were made using a Rohde and Schwarz Test Receiver and control software.



A preliminary scan and a final scan of the emissions were made by using test script of software; the emissions were measured using a Quasi-Peak Detector below 1GHz, Peak Detector and AV Detector above 1GHz. The maximal emission value was acquired by adjusting the antenna height, polarisation and turntable azimuth in accordance with the software setup. Normally, the height range of antenna was 1m to 4m, and the azimuth range of turntable was 0° to 360°. The receive antenna has two polarizations V and H.

A portable or small unlicensed wireless device shall be placed on a non-metallic test fixture or other nonmetallic support during testing. The supporting fixture shall permit orientation of the EUT in each of three orthogonal (x, y, z) axis positions such that emissions from the EUT are maximized.

The EUT communicates with the BTS simulator through Air interface. The EUT operated on the typical channel.

Measurement bandwidth: 30 MHz – 1000 MHz: 120 kHz

Measurement bandwidth: 1000 MHz – 10th Carrier Frequency: 1 MHz

4.5.8 Conducted Emission at Power Port

The Table-top EUT was placed upon a non-metallic table 0.8 m above the horizontal metal reference ground plane. EUT was connected to LISN and LISN was connected to reference Ground Plane. EUT was 80cm from LISN. The set-up and test methods were according to ANSI C63.10: 2009.

Conducted Disturbance at AC Port measurements were undertaken on the L and N Lines. The emissions were measured using a Quasi-Peak Detector and Average Detector.

The EUT communicates with the BTS simulator through Air interface, the BTS simulator controls the Wireless Modem to transmit the maximum power which defined in specification of product. The Wireless Modem operated on the typical channel.

Measurement bandwidth (RBW) for 150kHz to 30 MHz: 9 kHz;

4.6 Test Setups

4.6.1 Test Setup 1

The WLAN component's antenna ports(s) of the EUT are connected to the measurement instrument per an appropriate attenuator. The EUT is controlled by PC/software to emit the specified signals for the purpose of measurements.

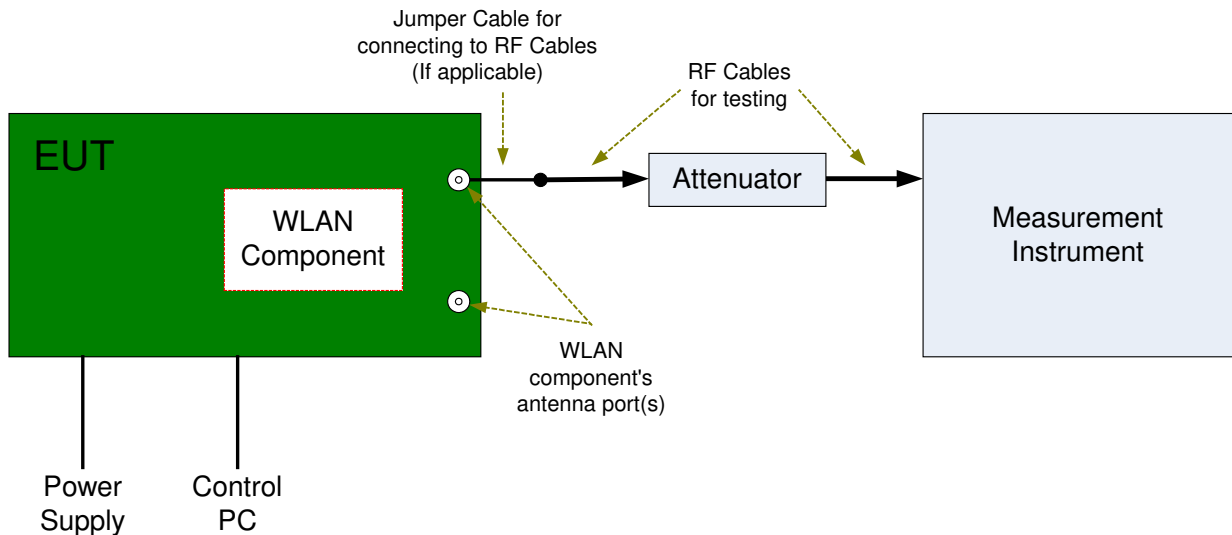

4.6.2 Test Setup 2

The test site semi-anechoic chamber has met the requirement of NSA tolerance 4 dB according to the standards: ANSI C63.4. The test distance is 3m. The setup is according to ANSI C63.4 and CAN/CSA-CEI/IEC CISPR 22.

The maximal emission value is acquired by adjusting the antenna height, polarisation and turntable azimuth. Normally, the height range of antenna is 1 m to 4 m, the azimuth range of turntable is 0° to 360°, and the receive antenna has two polarizations Vertical (V) and Horizontal (H).

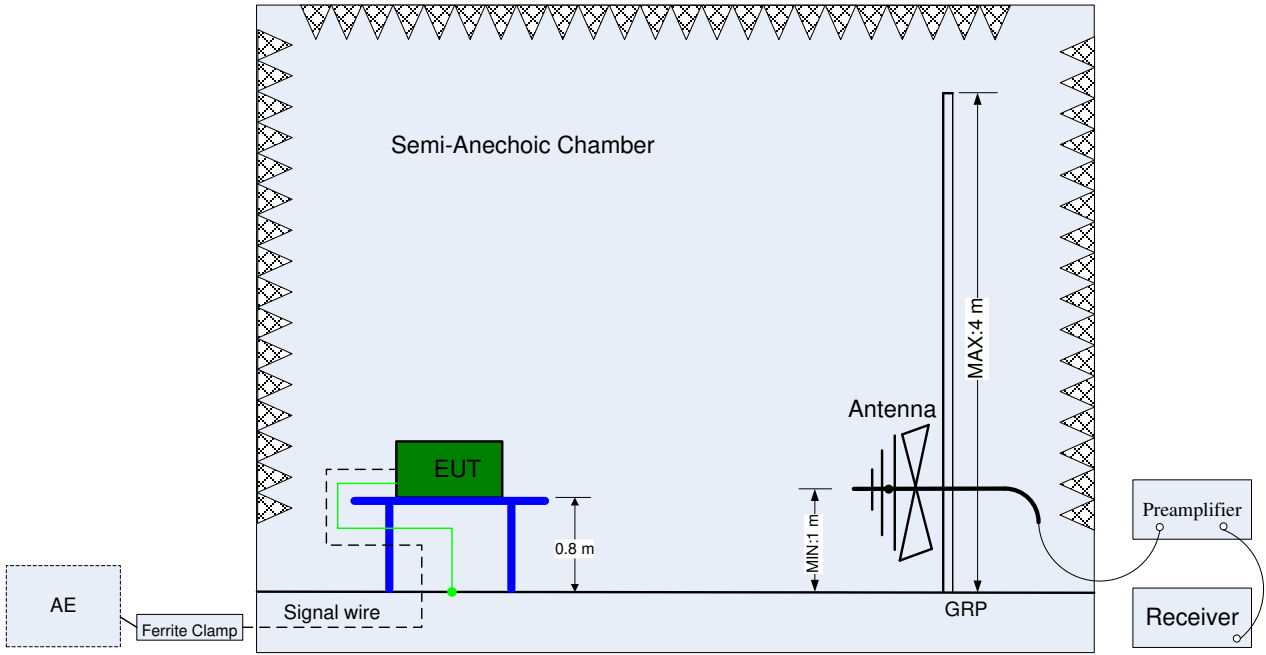

(Below 1 GHz)

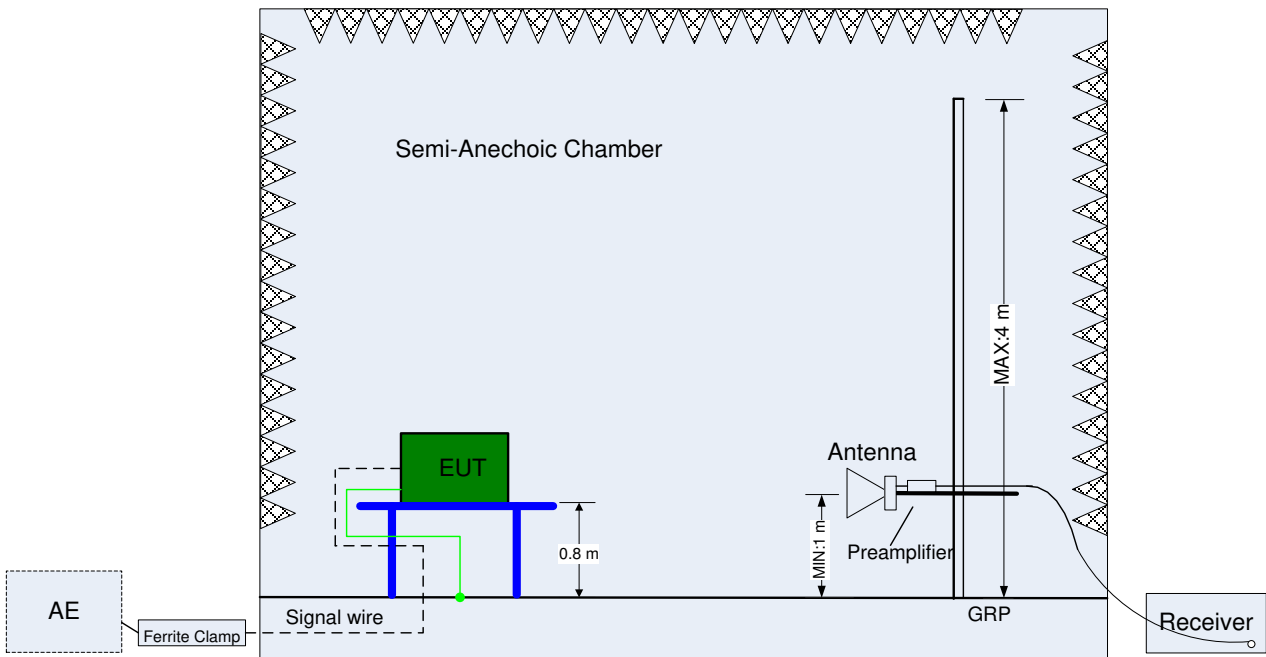

(Above 1 GHz)

4.6.3 Test Setup 3

The mains cable of the EUT (maybe per AC/DC Adapter) must be connected to LISN. The LISN shall be placed 0.8 m from the boundary of EUT and bonded to a ground reference plane for LISN mounted on top of the ground reference plane. This distance is between the closest points of the LISN and the EUT. All other units of the EUT and associated equipment shall be at least 0.8 m from the LISN.

Ground connections, where required for safety purposes, shall be connected to the reference ground point of the LISN and, where not otherwise provided or specified by the manufacturer, shall be of same length as the mains cable and run parallel to the mains connection at a separation distance of not more than 0.1 m.

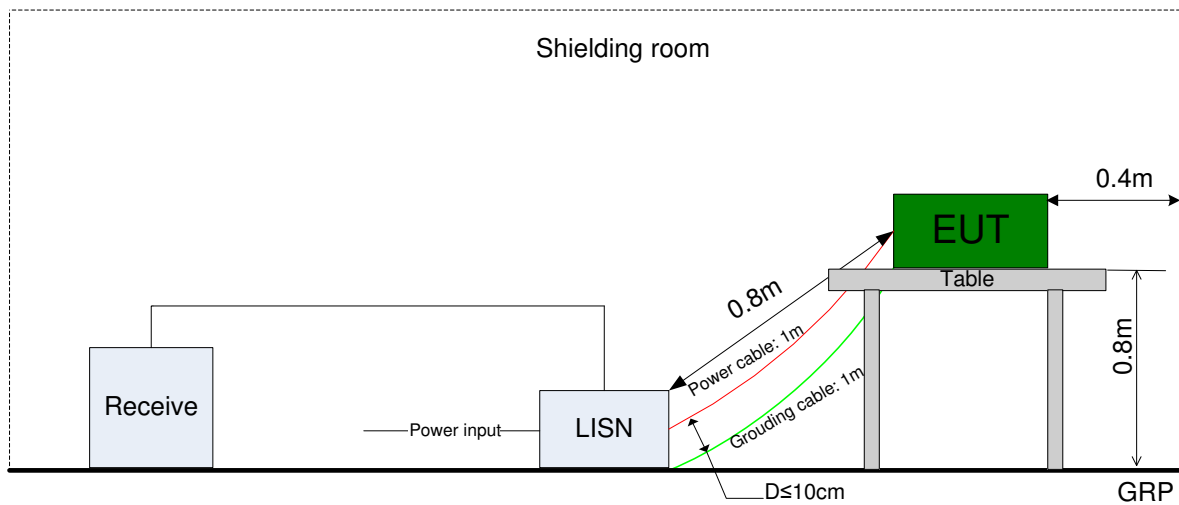

4.7 Test Conditions

| Test Case | Test Conditions | |
|---|--------------------|---|
| | Configuration | Description |
| DTS (6 dB) Bandwidth | Measurement Method | FCC KDB 558074 §8.2 Option 2. |
| | Test Environment | NTNV |
| | Test Setup | Test Setup 1 |
| | EUT Configuration | 11B_L, 11B_M, 11B_H 11G_L, 11G_M, 11G_H 11N20_L, 11 N20_M, 11 N20_H |
| Maximum Peak Conducted Output Power | Measurement Method | FCC KDB 558074 §9.1 .2 (integrated band power method). |
| | Test Environment | NTNV |
| | Test Setup | Test Setup 1 |
| | EUT Configuration | 11B_L, 11B_M, 11B_H 11G_L, 11G_M, 11G_H 11N20_L, 11 N20_M, 11 N20_H |
| Maximum Power Spectral Density Level | Measurement Method | FCC KDB 558074 §10.2 (peak PSD). |
| | Test Environment | NTNV |
| | Test Setup | Test Setup 1 |
| | EUT Configuration | 11B_L, 11B_M, 11B_H 11G_L, 11G_M, 11G_H 11N20_L, 11 N20_M, 11 N20_H |
| Band Edges Compliance | Measurement Method | FCC KDB 558074 §13.0. |
| | Test Environment | NTNV |
| | Test Setup | Test Setup 1 |
| | EUT Configuration | 11B_L, 11B_H 11G_L, 11G_H 11N20_L, 11 N20_H |
| Unwanted Emissions into Non-Restricted Frequency Bands | Measurement Method | FCC KDB 558074 §11.0 |
| | Test Environment | NTNV |
| | Test Setup | Test Setup 1 |
| | EUT Configuration | 11B_L, 11B_M, 11B_H 11G_L, 11G_M, 11G_H 11N20_L, 11 N20_M, 11 N20_H |
| AC Power Line Conducted Emissions | Measurement Method | AC mains conducted. |
| | Test Environment | NTNV |
| | Test Setup | Test Setup 3 |
| | EUT Configuration | 11B_L(Worst Conf.). |

**5 Main Test Instruments**

| Equipment Name | Manufacturer | Model | Serial Number | Cal Date | Cal- Due |
|---|---------------|-----------|----------------|------------|------------|
| Power supply | KEITHLEY | 2303 | 1288003 | 2012-11-19 | 2014-11-18 |
| Wireless Communication Test set | Agilent | N4010A | MY49081592 | 2013-10-29 | 2014-10-28 |
| Universal Radio Communication Tester | R&S | CMU200 | 113164 | 2013-07-18 | 2014-07-17 |
| Universal Radio Communication Tester | R & S | CMW500 | 126855 | 2013-08-08 | 2015-08-09 |
| Spectrum Analyzer | Agilent | E4440A | MY48250119 | 2013-08-09 | 2014-08-08 |
| Signal Analyzer | R&S | FSQ31 | 200021 | 2013-10-29 | 2014-10-28 |
| Spectrum Analyzer | Agilent | N9030A | MY49431698 | 2013-10-29 | 2014-10-28 |
| Temperature Chamber | WEISS | WKL64 | 56246002940010 | 2014-02-25 | 2015-02-24 |
| Vector Signal Generator | R&S | SMU200A | 104162 | 2013-10-29 | 2014-10-28 |
| Test receiver | R&S | ESU26 | 100150 | 2014-05-09 | 2015-05-08 |
| Spectrum analyzer | R&S | FSU3 | 200474 | 2013-12-24 | 2014-12-23 |
| Spectrum analyzer | R&S | FSU43 | 100144 | 2013-12-24 | 2014-12-23 |
| Double-Ridged Waveguide Horn Antenna (1G~18GHz) | R&S | HF907 | 100304 | 2013-02-02 | 2015-02-01 |
| Trilog Broadband Antenna (30M~3GHz) | SCHWARZ BECK | VULB 9163 | 9163-490 | 2013-02-02 | 2015-02-01 |
| LOOP Antennas(9kHz-30MHz) | R&S | HFH2-Z2 | 100262 | 2013-03-23 | 2015-03-22 |
| Pyramidal Horn Antenna(18GHz-26-5GHz) | ETS-LIND GREN | 3160-09 | 5140299 | 2013-03-05 | 2015-03-04 |
| Artificial Mains Network | R&S | ENV4200 | 100134 | 2013-12-24 | 2014-12-23 |
| Artificial Mains Network | R&S | ENV216 | 100382 | 2013-12-24 | 2014-12-23 |

END