

Test of Aruba Networks APIN0214, APIN0215

To: FCC 47 CFR Part 15.407 & IC RSS-210

Test Report Serial No.: ARUB179-U8 Rev B



TEST REPORT

FROM



Test of Aruba Networks APIN0214, APIN0215

to

To FCC 47 CFR Part 15.407 & IC RSS-210

Test Report Serial No.: ARUB179-U8 Rev B

Note: this report contains data with regard to the 5,250 - 5,350 and 5470 – 5725 MHz (DFS) bands Aruba Networks APIN0214 and APIN0215 Wireless Access Point. 5,150 - 5,250 MHz (non-DFS) band is reported in MiCOM Labs report ARUB179-U6 and 2.4 and 5.8 GHz test data are reported in MiCOM Labs test report ARUB179-U3

This report supersedes ARUB179-U8 Rev A

Applicant: Aruba Networks
1344 Crossman Avenue
Sunnyvale, California 94089
USA

Product Function: Wireless Access Point

Copy No: pdf Issue Date: 2nd September 2014

This Test Report is Issued Under the Authority of:

MiCOM Labs, Inc.

575 Boulder Court
Pleasanton, CA 94566 USA
Phone: +1 (925) 462-0304
Fax: +1 (925) 462-0306
www.micomlabs.com



TESTING CERT # 2381.01

MiCOM Labs is an ISO 17025 Accredited Testing Laboratory



Title: Aruba Networks APIN0214, APIN0215
To: FCC 47 CFR Part 15.407 & IC RSS-210
Serial #: ARUB179-U8 Rev B
Issue Date: 2nd September 2014
Page: 3 of 330

This page has been left intentionally blank

This test report may be reproduced in full only. The document may only be updated by MiCOM Labs personnel. Any changes will be noted in the Document History section of the report.



TABLE OF CONTENTS

ACCREDITATION, LISTINGS & RECOGNITION	6
TESTING ACCREDITATION	6
RECOGNITION	7
PRODUCT CERTIFICATION	8
1. TEST RESULT CERTIFICATE	10
2. REFERENCES AND MEASUREMENT UNCERTAINTY	11
2.1. Normative References	11
2.2. Test and Uncertainty Procedures	12
3. PRODUCT DETAILS AND TEST CONFIGURATIONS	13
3.1. Technical Details	13
3.2. Scope of Test Program.....	14
3.3. Equipment Model(s) and Serial Number(s).....	19
3.4. Antenna Details	19
3.5. Cabling and I/O Ports	20
3.6. Test Configurations	21
3.7. Equipment Modifications.....	22
3.8. Deviations from the Test Standard	22
3.9. Subcontracted Testing or Third Party Data	22
4. TESTING EQUIPMENT CONFIGURATION(S)	23
4.1. Conducted RF Emission Test Set-up.....	23
4.2. Radiated Spurious Emission Test Set-up > 1 GHz	25
4.3. Digital Emissions Test Set-up (0.03 – 1 GHz).....	26
4.4. ac Wireline Emission Test Set-up	27
4.5. Dynamic Frequency Selection	28
5. TEST SUMMARY	29
6. TEST RESULTS	32
6.1. Device Characteristics	32
6.1.1. <i>Conducted Testing</i>	32
6.1.2. <i>Radiated Emission Testing</i>	75
6.1.3. <i>AC Wireline Conducted Emissions (150 kHz – 30 MHz)</i>	126
6.1.4. <i>Dynamic Frequency Selection (DFS)</i>	129
6.2. Dynamic Frequency Selection (DFS) Test Results	143
6.2.1. <i>UNII Detection Bandwidth</i>	143
6.2.2. <i>Initial Channel Availability Check Time</i>	149
6.2.3. <i>Radar Burst at the Beginning of the Channel Availability Check Time: ...</i>	153
6.2.4. <i>Radar Burst at the End of the Channel Availability Check Time:.....</i>	157
6.2.5. <i>In-Service Monitoring for Channel Move Time, Channel Closing</i> <i>Transmission Time and Non-Occupancy Period</i>	161
6.2.6. <i>Statistical Performance Check</i>	168

This test report may be reproduced in full only. The document may only be updated by MiCOM Labs personnel. Any changes will be noted in the Document History section of the report.



Title: Aruba Networks APIN0214, APIN0215
To: FCC 47 CFR Part 15.407 & IC RSS-210
Serial #: ARUB179-U8 Rev B
Issue Date: 2nd September 2014
Page: 5 of 330

7. PHOTOGRAPHS	173
7.1. Conducted Test Setup	173
7.2. Test Setup - Digital Emissions > 1 GHz	174
7.3. Radiated Emissions Test Setup <1 GHz	175
7.4. ac Wireline Test Setup	176
7.5. Dynamic Frequency Selection (DFS)	177
8. TEST EQUIPMENT DETAILS	179
APPENDIX	181
A. SUPPORTING INFORMATION	181
A.1. CONDUCTED TEST PLOTS	181
A.1.1. 26 dB & 99% Bandwidth	182
A.1.2. Peak Power Spectral Density	242
A.1.3. Peak Excursion Ratio	322

This test report may be reproduced in full only. The document may only be updated by MiCOM Labs personnel. Any changes will be noted in the Document History section of the report.



Title: Aruba Networks APIN0214, APIN0215
To: FCC 47 CFR Part 15.407 & IC RSS-210
Serial #: ARUB179-U8 Rev B
Issue Date: 2nd September 2014
Page: 6 of 330

ACCREDITATION, LISTINGS & RECOGNITION

TESTING ACCREDITATION

MiCOM Labs, Inc. is an accredited Electrical testing laboratory per the international standard EN ISO/IEC 17025. The company is accredited by the American Association for Laboratory Accreditation (A2LA) www.a2la.org test laboratory number 2381.01. MiCOM Labs test schedule is available at the following URL; <http://www.a2la.org/scopepdf/2381-01.pdf>



This test report may be reproduced in full only. The document may only be updated by MiCOM Labs personnel. Any changes will be noted in the Document History section of the report.



RECOGNITION

MiCOM Labs, Inc has widely recognized Electrical testing capabilities. Our international recognition includes Conformity Assessment Body designation by APEC MRA** countries. Our test reports are widely accepted for global type approvals.

Country	Recognition Body	Status	Phase	Identification No.
USA	Federal Communications Commission (FCC)	TCB	-	US0159 Listing #: 102167
Canada	Industry Canada (IC)	FCB	APEC MRA 2	US0159 Listing #: 4143A-2
Japan	MIC (Ministry of Internal Affairs and Communication)	CAB	APEC MRA 2	RCB 210
	VCCI	--	--	A-0012
Europe	European Commission	NB	EU MRA	NB 2280
Australia	Australian Communications and Media Authority (ACMA)	CAB	APEC MRA 1	US0159
Hong Kong	Office of the Telecommunication Authority (OFTA)	CAB	APEC MRA 1	
Korea	Ministry of Information and Communication Radio Research Laboratory (RRL)	CAB	APEC MRA 1	
Singapore	Infocomm Development Authority (IDA)	CAB	APEC MRA 1	
Taiwan	National Communications Commission (NCC) Bureau of Standards, Metrology and Inspection (BSMI)	CAB	APEC MRA 1	
Vietnam	Ministry of Communication (MIC)	CAB	APEC MRA 1	

**APEC MRA – Asia Pacific Economic Community Mutual Recognition Agreement.

Is a recognition agreement under which test lab is accredited to regulatory standards of the APEC member countries.

Phase I - recognition for product testing

Phase II – recognition for both product testing and certification

N/A – Not Applicable

**EU MRA – European Union Mutual Recognition Agreement.

Is a recognition agreement under which test lab is accredited to regulatory standards of the EU member countries.

**NB – Notified Body

This test report may be reproduced in full only. The document may only be updated by MiCOM Labs personnel. Any changes will be noted in the Document History section of the report.



Title: Aruba Networks APIN0214, APIN0215
To: FCC 47 CFR Part 15.407 & IC RSS-210
Serial #: ARUB179-U8 Rev B
Issue Date: 2nd September 2014
Page: 8 of 330

PRODUCT CERTIFICATION

MiCOM Labs, Inc. is an accredited Product Certification Body per the international standard EN ISO/IEC 17065. The company is accredited by the American Association for Laboratory Accreditation (A2LA) www.a2la.org test laboratory number 2381.02. MiCOM Labs test schedule is available at the following URL; <http://www.a2la.org/scopepdf/2381-02.pdf>



USA Telecommunication Certification Body (TCB) - TCB Identifier – US0159

Industry Canada Certification Body - CAB Identifier – US0159

European Notified Body - Notified Body Identifier - 2280

Japan – Recognized Certification Body (RCB) - RCB Identifier - 210

This test report may be reproduced in full only. The document may only be updated by MiCOM Labs personnel. Any changes will be noted in the Document History section of the report.



Title: Aruba Networks APIN0214, APIN0215
To: FCC 47 CFR Part 15.407 & IC RSS-210
Serial #: ARUB179-U8 Rev B
Issue Date: 2nd September 2014
Page: 9 of 330

DOCUMENT HISTORY

Document History		
Revision	Date	Comments
Draft		
Rev B	2 nd September 2014	Section 3.4 Antenna Details updated, modified integral antenna gain to 5.0 dBi for 5 GHz operation
Rev A	19 th August 2014	Initial release

This test report may be reproduced in full only. The document may only be updated by MiCOM Labs personnel. Any changes will be noted in the Document History section of the report.



Title: Aruba Networks APIN0214, APIN0215
To: FCC 47 CFR Part 15.407 & IC RSS-210
Serial #: ARUB179-U8 Rev B
Issue Date: 2nd September 2014
Page: 10 of 330

1. TEST RESULT CERTIFICATE

Applicant:	Aruba Networks 1344 Crossman Avenue Sunnyvale, California 94089 USA	Tested By:	MiCOM Labs, Inc. 575 Boulder Court Pleasanton California, 94566, USA
EUT:	Wireless LAN Access point	Tel:	+1 925 462 0304
Model:	APIN0214 & APIN0215	Fax:	+1 925 462 0306
S/N:	APIN0214: CK0000562, APIN0215: CK0000823		
Test Date(s):	14th May - 10th July 2014	Website:	www.micomlabs.com

STANDARD(S)	TEST RESULTS
FCC 47 CFR Part 15.407 & IC RSS-210	EQUIPMENT COMPLIES

MiCOM Labs, Inc. tested the equipment mentioned in accordance with the requirements set forth in the above standards. Test results indicate that the equipment tested is capable of demonstrating compliance with the requirements as documented within this report.

Notes:

1. This document reports conditions under which testing was conducted and the results of testing performed.
2. Details of test methods used have been recorded and kept on file by the laboratory.
3. Test results apply only to the item(s) tested.

Approved & Released for MiCOM Labs, Inc. by:



TESTING CERT # 2381.01



Graeme Grieve
Quality Manager MiCOM Labs,

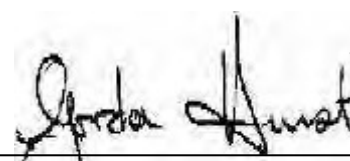

Gordon Hurst
President & CEO MiCOM Labs, Inc.

This test report may be reproduced in full only. The document may only be updated by MiCOM Labs personnel. Any changes will be noted in the Document History section of the report.

2. REFERENCES AND MEASUREMENT UNCERTAINTY

2.1. Normative References

Ref.	Publication	Year	Title
(i)	FCC 47 CFR Part 15.407	2012	Code of Federal Regulations
(ii)	FCC 06-96	June 2006	Memorandum Opinion and Order
(iii)	FCC OET KDB 662911	31 st October 2013	Emissions Testing of Transmitters with Multiple Outputs in the Same Band
(iv)	Industry Canada RSS-210 Annex 9	2010	Low Power License-Exempt Radiocommunication Devices (All Frequency Bands): Category 1 Equipment
(v)	ICES-003	31 st August 2013	Spectrum Management and Telecommunications Policy Interference-Causing Equipment Standard Digital Apparatus; Issue 5
(vi)	Industry Canada RSS-Gen	2010	General Requirements and Information for the Certification of Radiocommunication Equipment
(vii)	ANSI C63.4	2009	American National Standards for Methods of Measurement of Radio-Noise Emissions from Low-Voltage Electrical and Electronic Equipment in the Range of 9 kHz to 40 GHz
(viii)	CISPR 22/ EN 55022	2010	Limits and Methods of Measurements of Radio Disturbance Characteristics of Information Technology Equipment
(ix)	M 3003	Edition 1 Dec. 1997	Expression of Uncertainty and Confidence in Measurements
(x)	LAB34	Edition 1 Aug 2002	The expression of uncertainty in EMC Testing
(xi)	ETSI TR 100 028	2001	Parts 1 and 2 Electromagnetic compatibility and Radio Spectrum Matters (ERM); Uncertainties in the measurement of mobile radio equipment characteristics
(xii)	A2LA	July 2012	Reference to A2LA Accreditation Status – A2LA Advertising Policy
(xiii)	FCC Public Notice – DA 02-2138	2002	Guidelines for Assessing Unlicensed National Information Infrastructure (U-NII) Devices



Title: Aruba Networks APIN0214, APIN0215
To: FCC 47 CFR Part 15.407 & IC RSS-210
Serial #: ARUB179-U8 Rev B
Issue Date: 2nd September 2014
Page: 12 of 330

2.2. Test and Uncertainty Procedures

Conducted and radiated emission measurements were conducted in accordance with American National Standards Institute ANSI C63.4, listed in the Normative References section of this report.

Measurement uncertainty figures are calculated in accordance with ETSI TR 100 028 Parts 1 and 2.

Measurement uncertainties stated are based on a standard uncertainty multiplied by a coverage factor $k = 2$, providing a level of confidence of approximately 95 % in accordance with UKAS document M 3003 listed in the Normative References section of this report.

This test report may be reproduced in full only. The document may only be updated by MiCOM Labs personnel. Any changes will be noted in the Document History section of the report.



Title: Aruba Networks APIN0214, APIN0215
To: FCC 47 CFR Part 15.407 & IC RSS-210
Serial #: ARUB179-U8 Rev B
Issue Date: 2nd September 2014
Page: 13 of 330

3. PRODUCT DETAILS AND TEST CONFIGURATIONS

3.1. Technical Details

Details	Description
Purpose:	Test of the Aruba Networks APIN0214, APIN0215 in the frequency range 5,150 - 5,250 MHz to FCC Part 15.407 and Industry Canada RSS-210 regulations.
Applicant:	Aruba Networks 1344 Crossman Avenue Sunnyvale, California 94089, USA
Manufacturer:	As applicant
Laboratory performing the tests:	MiCOM Labs, Inc. 575 Boulder Court, Pleasanton, California 94566 USA
Test report reference number:	ARUB179-U8 Rev B
Date EUT received:	5 th May 2014
Standard(s) applied:	FCC 47 CFR Part 15.407 & IC RSS-210
Dates of test (from - to):	14th May - 10th July 2014
No of Units Tested:	Two
Type of Equipment:	802.11a/b/g/n/ac Wireless Access Point 3x3 Spatial Multiplexing MIMO configuration
Applicants Trade Name:	Wireless Access Point
Model(s):	APIN0214 & APIN0215
Location for use:	Indoor only
Declared Frequency Range(s):	5,250 – 5,350 and 5,470 – 5,725 MHz
Hardware Rev	Version P3
Software Rev	AOS 6.4.1.0
Type of Modulation:	Per 802.11 – OFDM
EUT Modes of Operation:	802.11a/n/ac
Declared Nominal Output Power: (Average Power)	802.11a/n/ac: +22.0 dBm
Transmit/Receive Operation:	Time Division Duplex
System Beam Forming:	APIN0214 & APIN0215 has no capability for antenna beam forming
Rated Input Voltage and Current:	POE 48 - 53 Vdc 350 mA 12 Vdc 1.5 A
Operating Temperature Range:	Declared range 0° to +50°.
ITU Emission Designator:	802.11a 16M6D1D 802.11n HT-20 16M6D1D 802.11n HT-40 36M5D1D 802.11ac-80 75M7D1D
Equipment Dimensions:	170mm x 170mm x 45mm
Weight:	1.3 lbs
Primary function of equipment:	Wireless Access Point for transmitting data and voice.

This test report may be reproduced in full only. The document may only be updated by MiCOM Labs personnel. Any changes will be noted in the Document History section of the report.



Title: Aruba Networks APIN0214, APIN0215
To: FCC 47 CFR Part 15.407 & IC RSS-210
Serial #: ARUB179-U8 Rev B
Issue Date: 2nd September 2014
Page: 14 of 330

3.2. Scope of Test Program

Aruba Networks APIN0214, APIN0215 Access Point RF Testing

The scope of the test program was to test the Aruba Networks APIN0214, APIN0215 Wireless LAN Access Point, 3x3 Spatial Multiplexing MIMO configurations in the frequency range 5,250 - 5,350 and 5,470 – 5,725 MHz for compliance against FCC 47 CFR Part 15.407 and Industry Canada RSS-210 specifications.

Model Identification

APIN0214: External Antenna (Reverse SMA)

APIN0215: Integral

APIN0214 and APIN0215 Operational Modes

Client did not provide software capability for the following operational modes and claimed these were covered under 802.11n HT-20 and 802.11n HT-40.

i).. VHT-20

ii)..VHT-40

FCC OET KDB Implementation

This test program implements the following FCC KDB – 662911 31st October 2013;
Emissions Testing of Transmitters with Multiple Outputs in the Same Band

The KDB document provides guidance for measurements of conducted output emissions of devices that employ a single transmitter with multiple outputs in the same band, with the outputs occupying the same or overlapping frequency ranges. It applies to EMC compliance measurements on devices that transmit on multiple antennas simultaneously in the same or overlapping frequency ranges through a coordinated process. Examples include, but are not limited to, devices employing beam forming or multiple-input and multiple-output (MIMO.) This guidance applies to both licensed and unlicensed devices wherever the FCC rules call for conducted output measurements. Guidance is provided for in-band, out-of-band and spurious emission measurements.

This guidance does not apply to the multiple transmitters included in a composite device, such as a device that combines an 802.11 modem with a cell phone in one enclosure with each driving its own antenna.

This test report may be reproduced in full only. The document may only be updated by MiCOM Labs personnel. Any changes will be noted in the Document History section of the report.

Aruba Networks Inc
APIN0214 External Antenna 802.11 a/b/g/n/ac Wireless Access Point



This test report may be reproduced in full only. The document may only be updated by MiCOM Labs personnel. Any changes will be noted in the Document History section of the report.

Aruba Networks Inc
APIN0215 Integral Antenna 802.11 a/b/g/n/ac Wireless Access Point



This test report may be reproduced in full only. The document may only be updated by MiCOM Labs personnel. Any changes will be noted in the Document History section of the report.

Aruba Networks Inc
802.11 a/b/g/n/ac Wireless Access Point (Rear)



This test report may be reproduced in full only. The document may only be updated by MiCOM Labs personnel. Any changes will be noted in the Document History section of the report.

Aruba Networks Inc
802.11 a/b/g/n/ac Wireless Access Point Label



This test report may be reproduced in full only. The document may only be updated by MiCOM Labs personnel. Any changes will be noted in the Document History section of the report.



Title: Aruba Networks APIN0214, APIN0215
To: FCC 47 CFR Part 15.407 & IC RSS-210
Serial #: ARUB179-U8 Rev B
Issue Date: 2nd September 2014
Page: 19 of 330

3.3. Equipment Model(s) and Serial Number(s)

Type (EUT/Support)	Equipment Description (Including Brand Name)	Mfr	Model No.	Serial No.
EUT	Wireless LAN Access Point	Aruba Networks	APIN0214	CK0000562
EUT	Wireless LAN Access Point (Integral Antenna)	Aruba Networks	APIN0215 (Radiated only)	CK0000823
Support	Laptop PC	IBM	Thinkpad	None

3.4. Antenna Details

APIN0214 External Antennas

Model	Type	Gain	Freq. Band	Note
		dBi	MHz	
AP-ANT-1B	Omni	3.8	2400 - 2500	
		5.8	4900 - 5875	
AP-ANT-13B	Omni	4.4	2400 - 2500	
		3.3	4900 - 5900	
AP-ANT-16	Omni	3.9	2400 - 2500	
		4.7	4900 - 5900	
AP-ANT-17	Directional 120degr.	6.0	2400 - 2500	
		5.0	4900 - 5875	
AP-ANT-18	Directional 60degr.	7.5	2400 - 2500	
		7.5	5150 - 5875	
AP-ANT-19	Omni	3.0	2400 - 2500	
		6.0	5150 - 5875	
AP-ANT-20	Omni	2.0	2400 - 2500	
		2.0	5150 - 5875	

This test report may be reproduced in full only. The document may only be updated by MiCOM Labs personnel. Any changes will be noted in the Document History section of the report.



APIN0215 Integral Antennas

Model	Type	Gain	Freq. Band	Note
		dBi	MHz	
metal sheet	Omni	4.0	2400 - 2500	(3x per band, per unit)
metal sheet	Omni	5.0	5150 - 5875	(3x per band, per unit)

3.5. Cabling and I/O Ports

Number and type of I/O ports

1. 10/100/1000 Ethernet (POE) (maximum cable length 100m)
2. USB - Serial maintenance terminal
3. 12 Vdc, jack connector
4. RF Antenna Connectors (x3) – Reverse SMA (APIN0214 Only)



3.6. Test Configurations

Testing was performed to determine the highest power level versus bit rate. The variant with the highest power was used to exercise the product.

Matrix of test configurations

Bands (MHz)	Operational Mode(s) (802.11)	Data Rates with Highest Power	Frequencies (MHz)
5250 - 5350 5470 - 5725	Legacy	6 MBit/s	5260, 5300, 5320 5500, 5580, 5700
	HT-20, ac-20	6.5 MBit/s	
	HT-40, ac-40	13.5 MBit/s	5270, 5310 5510, 5550, 5670
	ac-80	29.3 MBit/s	5290, 5530, 5690

Spurious Emission and Band-Edge Test Strategy, Band 5,250 – 5250

11a	11n HT-20	11n HT-40	11n ac-80
SE 5260			
SE 5300			
SE 5320			
BE 5350	BE 5350	BE 5350	BE 5350

Band 5,470 – 5725

11a	11n HT-20	11n HT-40	11n ac-80
SE 5500			
SE 5580			
SE 5700			
BE 5470	BE 5470	BE 5470	BE 5470

KEY:-

SE – Spurious Emissions

BE – Band-Edge



Title: Aruba Networks APIN0214, APIN0215
To: FCC 47 CFR Part 15.407 & IC RSS-210
Serial #: ARUB179-U8 Rev B
Issue Date: 2nd September 2014
Page: 22 of 330

3.7. Equipment Modifications

The following modifications were required to bring the equipment into compliance:

1. NONE

3.8. Deviations from the Test Standard

The following deviations from the test standard were required in order to complete the test program:

1. NONE

3.9. Subcontracted Testing or Third Party Data

1. NONE

This test report may be reproduced in full only. The document may only be updated by MiCOM Labs personnel. Any changes will be noted in the Document History section of the report.

4. TESTING EQUIPMENT CONFIGURATION(S)

4.1. Conducted RF Emission Test Set-up

The following tests were performed using the conducted test set-up shown in the diagram below.

1. Section 6.1.1.1. 26 dB and 99% Bandwidth
2. Section 6.1.1.2. Maximum Conducted Output Power
3. Section 6.1.1.3. Peak Power Spectral Density
4. Section 6.1.1.4. Peak Excursion Ratio

Conducted Test Set-Up Pictorial Representation

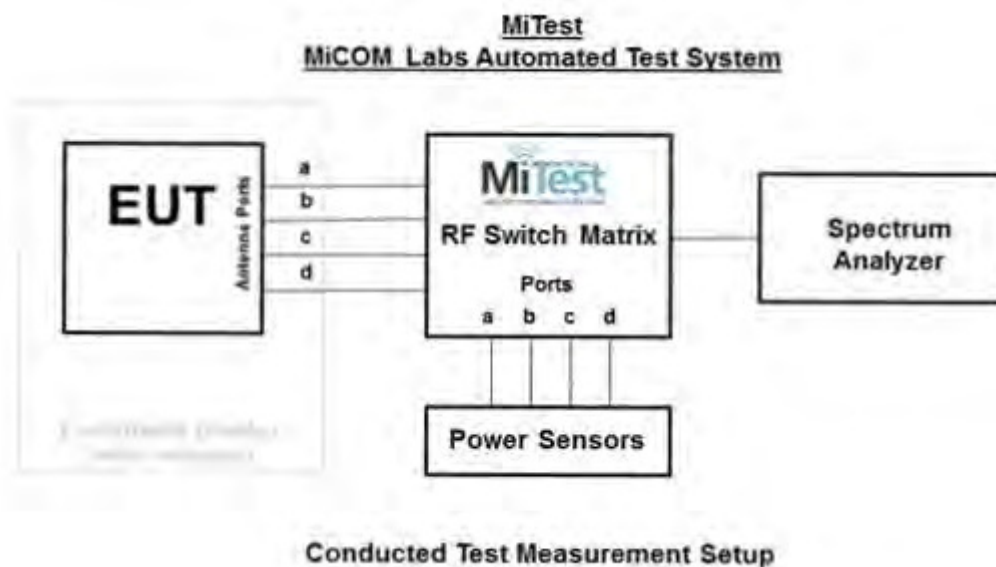

Traceability

Test Equipment Utilized for Conducted Testing

075, 117, 158, 223, 376, 378, 380, 390, 398, 405, RF#1 SMA#SA, RF#1 SMA#1, RF#1 SMA#2, RF#1 SMA#3, RF#1 SMA#4

This test report may be reproduced in full only. The document may only be updated by MiCOM Labs personnel. Any changes will be noted in the Document History section of the report.

Measurement and Presentation of Test Data

The measurement and graphical data presented in this test report was generated automatically using state-of-the-art technology creating an easy to read report structure. Numerical measurement data is separated from supporting graphical data (plots) through hyperlinks. Numerical measurement data can be reviewed without scrolling through numerous graphical pages to arrive at the next data matrix.

Plots have been relegated into the Appendix 'Graphical Data'.

Test and report automation was performed by [MiTest](#). [MiTest](#) is an automated test system developed by MiCOM Labs. [MiTest](#) is the first cloud based modular test system enabling end-to-end automation of regulatory compliance testing for conducted RF testing.



The MiCOM Labs “[MiTest](#)” Automated Test System“ (Patent Pending)

This test report may be reproduced in full only. The document may only be updated by MiCOM Labs personnel. Any changes will be noted in the Document History section of the report.

4.2. Radiated Spurious Emission Test Set-up > 1 GHz

The following tests were performed using the conducted test set-up shown in the diagram below.

1. Section 6.1.2.1 through 12

Radiated Emission Measurement Setup – Above 1 GHz

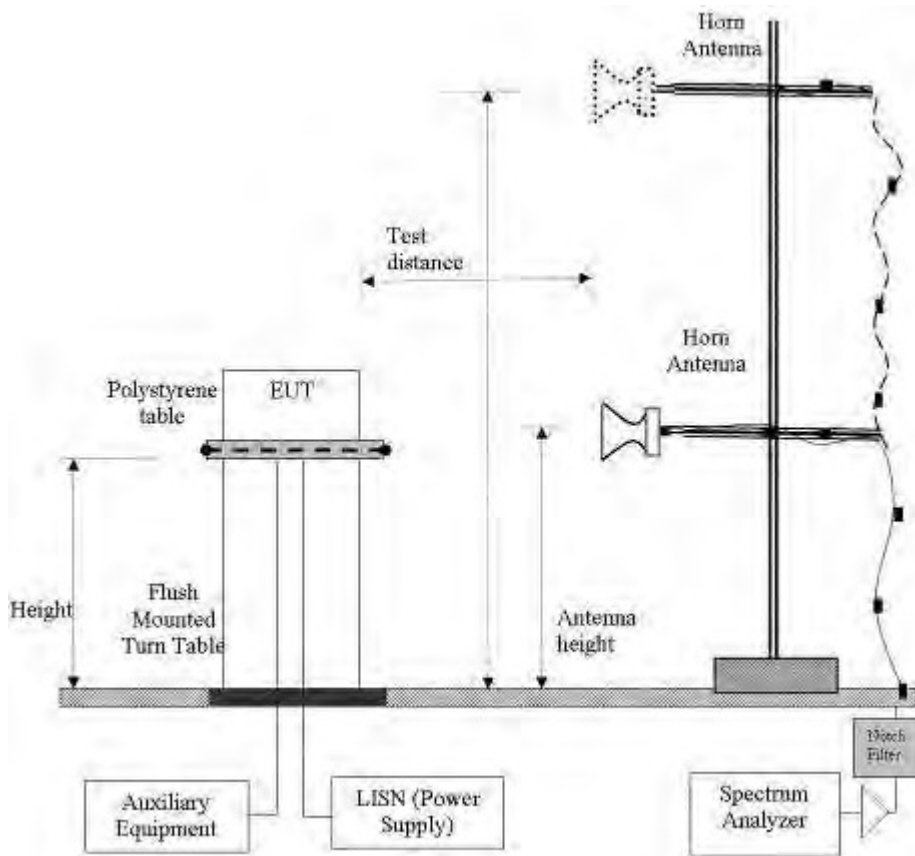

Traceability

Test Equipment Utilized for Radiated Emission Testing > 1GHz

158, 252, 310, 312, 377, 393, 396, 399, 406, 411, 413, 415, 416, 502, 503

4.3. Digital Emissions Test Set-up (0.03 – 1 GHz)

The following tests were performed using the conducted test set-up shown in the diagram below.

1. Section 6.1.2.13

Digital Emission Measurement Setup – Below 1 GHz

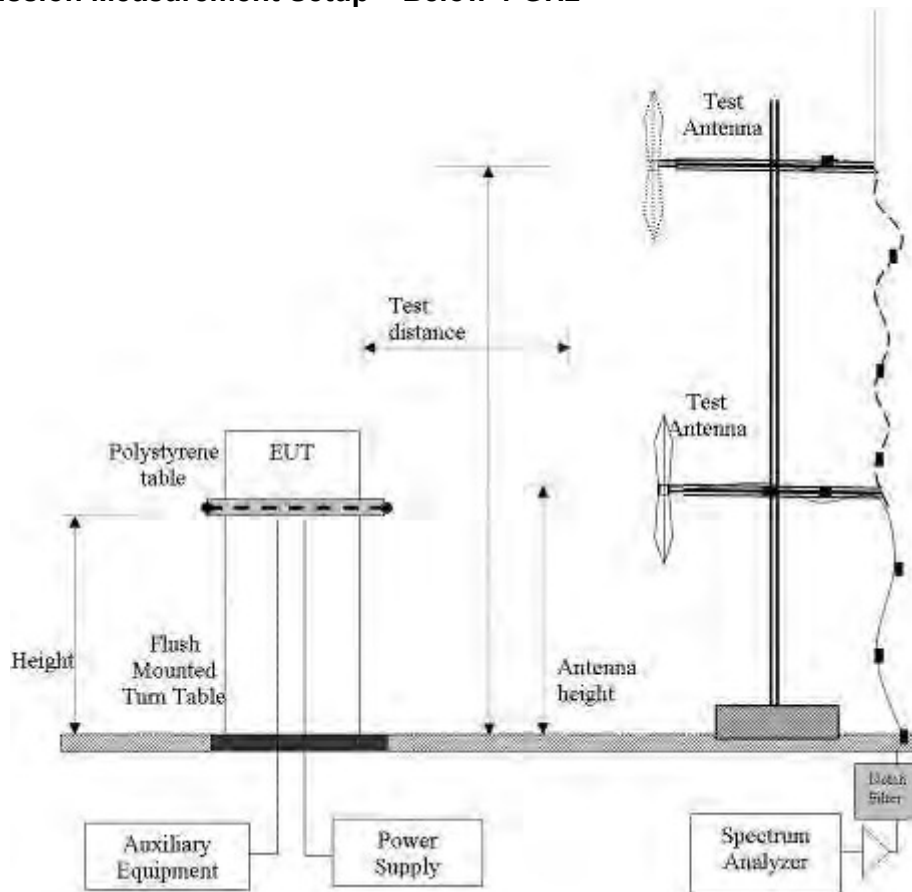

Traceability

Test Equipment Utilized for Radiated Emission Testing 0.03 - 1GHz

158, 252, 310, 312, 338, 377, 393, 396, 397, 411, 413, 415, 416, 502, 503

This test report may be reproduced in full only. The document may only be updated by MiCOM Labs personnel. Any changes will be noted in the Document History section of the report.

4.4. ac Wireline Emission Test Set-up

The following tests were performed using the conducted test set-up shown in the diagram below.

1. Section 6.1.3 ac Wireline Conducted Emissions

Conducted Test Set-Up Pictorial Representation

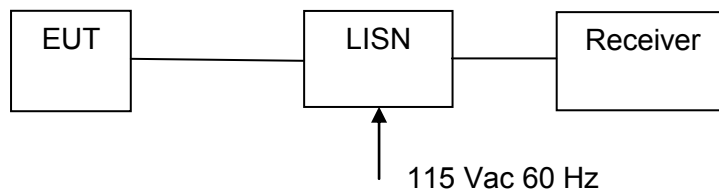

Measurement set up for ac Wireline Conducted Emissions Test

Traceability

Test Equipment Utilized for Radiated Emission Testing 0.03 - 1GHz

158, 190, 378

4.5. Dynamic Frequency Selection

Conducted Test Setup

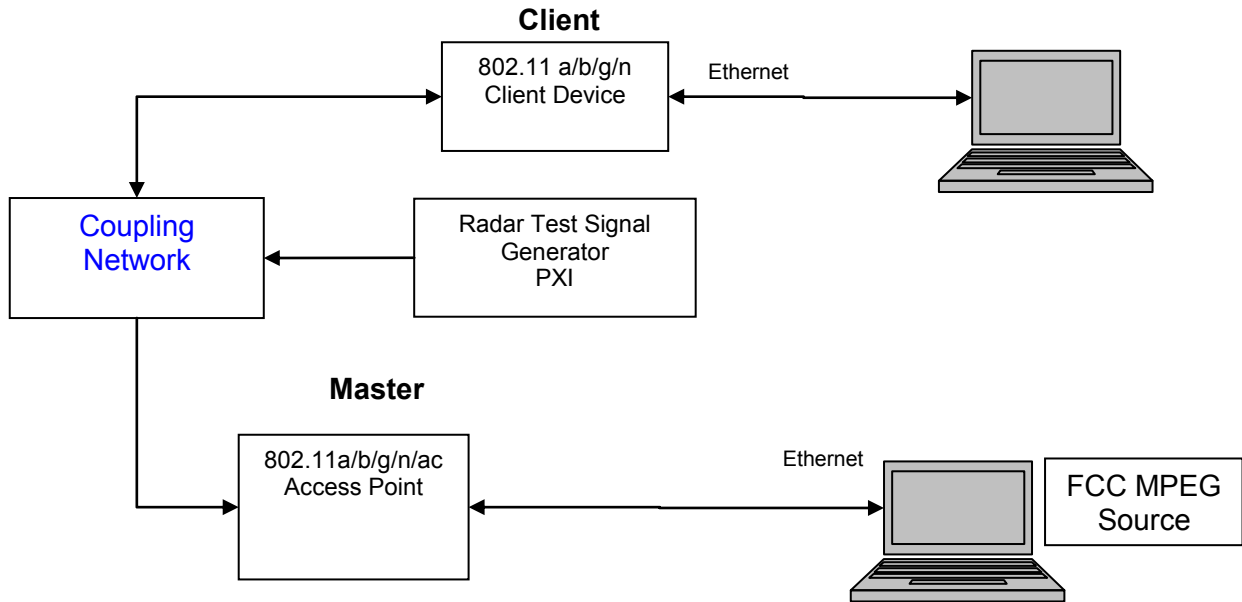

Traceability

Test Equipment Utilized for Radiated Emission Testing 0.03 - 1GHz
--

158, 359, 378



5. TEST SUMMARY

List of Measurements

The following table represents the list of measurements required under the **FCC CFR47 Part 15.407** and **Industry Canada RSS-210** and **Industry Canada RSS-Gen**.

Section(s)	Test Items	Description	Condition	Result	Test Report Section
15.407(a) A9.2(2) 4.4	26dB and 99% Emission BW	Emission bandwidth measurement	Conducted	Complies	6.1.1.1 A.1.1
15.407(a) A9.2(2) 4.6	Maximum Conducted Output Power	Power Measurement	Conducted	Complies	6.1.1.2
15.407(a) A9.2(2)	Peak Power Spectral Density	PPSD	Conducted	Complies	6.1.1.3 A.1.2
15.407(a)(6)	Peak Excursion Ratio	<13dB in any 1MHz bandwidth	Conducted	Complies	6.1.1.4 A.1.3
15.407(g) 15.31 2.1 4.5	Frequency Stability	Limits: contained within band of operation at all times.	Applicant declaration	Complies	6.1.1.5
15.407(f) 5.5	Radio Frequency Radiation Exposure	Exposure to radio frequency energy levels, Maximum Permissible Exposure (MPE)	Conducted	See included MPE exhibit	--

This test report may be reproduced in full only. The document may only be updated by MiCOM Labs personnel. Any changes will be noted in the Document History section of the report.



List of Measurements (continued)

The following table represents the list of measurements required under the **FCC CFR47 Part 15.407** and **Industry Canada RSS-210** and **Industry Canada RSS-Gen**.

Section(s)	Test Items	Description	Condition	Result	Test Report Section
15.407(b)(2) 15.205(a) 15.209(a) 2.2 2.6 A9.3(2) 4.7	Radiated Emissions		Radiated		6.1.2
	Transmitter Radiated Spurious Emissions	Emissions above 1 GHz		Complies	6.1.2.1 6.1.2.2 6.1.2.3
	Radiated Band Edge	Band edge results		Complies	6.1.2.1 6.1.2.2 6.1.2.3
15.407(b)(6) 15.205(a) 15.209(a) 2.2	Radiated Emissions	Emissions <1 GHz (30M-1 GHz)		Complies	6.1.2.4
15.407(b)(6) 15.207 7.2.2	AC Wireline Conducted Emissions 150 kHz–30 MHz	Conducted Emissions	Conducted	Complies	6.1.3

Note 1: Test results reported in this document relate only to the items tested

Note 2: The required tests demonstrated compliance as per client declaration of test configuration, monitoring methodology and associated pass/fail criteria

Note 3: Section 3.7 Equipment Modifications highlights the equipment modifications that were required to bring the product into compliance with the above test matrix



List of Measurements (cont'd)

Dynamic Frequency Selection (DFS)

The following table represents the list of measurements required under the **FCC CFR47 Part 15.407(h)(2)** and **FCC Memorandum Opinion and Order FCC 06-96 (Compliance Measurement procedures for Unlicensed National Information Infrastructure devices operating in the 5250-5350 MHz and 5470-5725 MHz bands incorporating dynamic frequency selection)**.

Tests performed on Master Device

Section	Test Items	Description	Condition	Result	Test Report Section
	DFS	Dynamic Frequency Selection	Conducted	Complies	6.1.4
7.8.1	Detection Bandwidth	UNII Detection Bandwidth	Conducted	Complies	
7.8.2.1	Performance Requirements Check	Initial Channel Availability Check Time	Conducted	Complies	
7.8.2.2		Radar Burst at the Beginning of the Channel Availability Check Time	Conducted	Complies	
7.8.2.3		Radar Burst at the End of the Channel Availability Check Time	Conducted	Complies	
7.8.3	In-Service Monitoring	In-Service Monitoring for Channel Move Time, Channel Closing Transmission Time and Non-Occupancy Period	Conducted	Complies	
7.8.4	Radar Detection	Statistical Performance Check	Conducted	Complies	

This test report may be reproduced in full only. The document may only be updated by MiCOM Labs personnel. Any changes will be noted in the Document History section of the report.



Title: Aruba Networks APIN0214, APIN0215
To: FCC 47 CFR Part 15.407 & IC RSS-210
Serial #: ARUB179-U8 Rev B
Issue Date: 2nd September 2014
Page: 32 of 330

6. TEST RESULTS

6.1. Device Characteristics

6.1.1. Conducted Testing

6.1.1.1. 26 dB and 99 % Bandwidth

Conducted Test Conditions for 26 dB and 99% Bandwidth			
Standard:	FCC CFR 47:15.407	Ambient Temp. (°C):	24.0 - 27.5
Test Heading:	26 dB and 99 % Bandwidth	Rel. Humidity (%):	32 - 45
Standard Section(s):	15.407 (a)	Pressure (mBars):	999 - 1001
Reference Document(s):	KDB 789033 - D01 DTS General UNII Test Procedures v01		

Test Procedure for 26 dB and 99% Bandwidth Measurement

The bandwidth at 26 dB and 99 % is measured with a spectrum analyzer connected to the antenna terminal, while EUT is operating in transmission mode at the appropriate center frequency. KDB 789033 Section 5.1 Emission Bandwidth was used in order to prove compliance. The Resolution Bandwidth was set to approximately 1% of the emission bandwidth.

This test report may be reproduced in full only. The document may only be updated by MiCOM Labs personnel. Any changes will be noted in the Document History section of the report.



Title: Aruba Networks APIN0214, APIN0215
To: FCC 47 CFR Part 15.407 & IC RSS-210
Serial #: ARUB179-U8 Rev B
Issue Date: 2nd September 2014
Page: 33 of 330

Equipment Configuration for 26 dB & 99% Occupied Bandwidth

Variant:	802.11a	Duty Cycle (%):	90
Data Rate:	6 MBit/s	Antenna Gain (dBi):	Not Applicable
Modulation:	OFDM	Beam Forming Gain (Y):	Not Applicable
TPC:	Not Applicable	Tested By:	SB
Engineering Test Notes: Image built 2014-05-07 at 04:01:39 EDT (gcc version 4.5.1)			

Test Measurement Results

Test Frequency	Measured 26 dB Bandwidth (MHz)				26 dB Bandwidth (MHz)			
	Port(s)				Highest	Lowest		
MHz	a	b	c	d	Highest	Lowest		
5260.0	19.639	19.238	19.840		19.840	19.238		
5300.0	19.639	19.238	19.940		19.940	19.238		
5320.0	19.639	19.038	19.940		19.940	19.038		

Test Frequency	Measured 99% Bandwidth (MHz)				99% Bandwidth (MHz)			
	Port(s)				Highest	Lowest		
MHz	a	b	c	d	Highest	Lowest		
5260.0	16.633	16.533	16.633		16.633	16.533		
5300.0	16.633	16.533	16.533		16.633	16.533		
5320.0	16.633	16.533	16.533		16.633	16.533		

Traceability to Industry Recognized Test Methodologies

Work Instruction:	WI-03 MEASURING RF SPECTRUM MASK
Measurement Uncertainty:	±2.81 dB

Note: click the links in the above matrix to view the graphical image (plot).

This test report may be reproduced in full only. The document may only be updated by MiCOM Labs personnel. Any changes will be noted in the Document History section of the report.



Title: Aruba Networks APIN0214, APIN0215
To: FCC 47 CFR Part 15.407 & IC RSS-210
Serial #: ARUB179-U8 Rev B
Issue Date: 2nd September 2014
Page: 34 of 330

Equipment Configuration for 26 dB & 99% Occupied Bandwidth

Variant:	802.11ac-80	Duty Cycle (%):	90
Data Rate:	27.5 MBit/s	Antenna Gain (dBi):	Not Applicable
Modulation:	OFDM	Beam Forming Gain (Y):	Not Applicable
TPC:	Not Applicable	Tested By:	SB
Engineering Test Notes: Image built 2014-05-07 at 04:01:39 EDT (gcc version 4.5.1)			

Test Measurement Results

Test Frequency	Measured 26 dB Bandwidth (MHz)				26 dB Bandwidth (MHz)			
	Port(s)				Highest	Lowest		
MHz	a	b	c	d				
5290.0	80.160	79.760	80.160		80.160	79.760		

Test Frequency	Measured 99% Bandwidth (MHz)				99% Bandwidth (MHz)			
	Port(s)				Highest	Lowest		
MHz	a	b	c	d				
5290.0	75.752	75.752	75.752		75.752	75.752		

Traceability to Industry Recognized Test Methodologies

Work Instruction:	WI-03 MEASURING RF SPECTRUM MASK
Measurement Uncertainty:	±2.81 dB

Note: click the links in the above matrix to view the graphical image (plot).

This test report may be reproduced in full only. The document may only be updated by MiCOM Labs personnel. Any changes will be noted in the Document History section of the report.



Title: Aruba Networks APIN0214, APIN0215
To: FCC 47 CFR Part 15.407 & IC RSS-210
Serial #: ARUB179-U8 Rev B
Issue Date: 2nd September 2014
Page: 35 of 330

Equipment Configuration for 26 dB & 99% Occupied Bandwidth

Variant:	802.11n HT-20	Duty Cycle (%):	85
Data Rate:	6.5 MBit/s	Antenna Gain (dBi):	Not Applicable
Modulation:	OFDM	Beam Forming Gain (Y):	Not Applicable
TPC:	Not Applicable	Tested By:	SB
Engineering Test Notes: Image built 2014-05-07 at 04:01:39 EDT (gcc version 4.5.1)			

Test Measurement Results

Test Frequency	Measured 26 dB Bandwidth (MHz)				26 dB Bandwidth (MHz)			
	Port(s)				Highest	Lowest		
MHz	a	b	c	d	Highest	Lowest		
5260.0	19.739	19.038	19.439		19.739	19.038		
5300.0	19.739	18.938	19.439		19.739	18.938		
5320.0	19.739	18.838	19.439		19.739	18.838		

Test Frequency	Measured 99% Bandwidth (MHz)				99% Bandwidth (MHz)			
	Port(s)				Highest	Lowest		
MHz	a	b	c	d	Highest	Lowest		
5260.0	16.633	16.533	16.533		16.633	16.533		
5300.0	16.633	16.533	16.533		16.633	16.533		
5320.0	16.633	16.533	16.533		16.633	16.533		

Traceability to Industry Recognized Test Methodologies

Work Instruction:	WI-03 MEASURING RF SPECTRUM MASK
Measurement Uncertainty:	±2.81 dB

Note: click the links in the above matrix to view the graphical image (plot).

This test report may be reproduced in full only. The document may only be updated by MiCOM Labs personnel. Any changes will be noted in the Document History section of the report.



Title: Aruba Networks APIN0214, APIN0215
To: FCC 47 CFR Part 15.407 & IC RSS-210
Serial #: ARUB179-U8 Rev B
Issue Date: 2nd September 2014
Page: 36 of 330

Equipment Configuration for 26 dB & 99% Occupied Bandwidth

Variant:	802.11n HT-40	Duty Cycle (%):	90
Data Rate:	13.5 MBit/s	Antenna Gain (dBi):	Not Applicable
Modulation:	OFDM	Beam Forming Gain (Y):	Not Applicable
TPC:	Not Applicable	Tested By:	SB
Engineering Test Notes: Image built 2014-05-07 at 04:01:39 EDT (gcc version 4.5.1)			

Test Measurement Results

Test Frequency	Measured 26 dB Bandwidth (MHz)				26 dB Bandwidth (MHz)			
	Port(s)				Highest	Lowest		
MHz	a	b	c	d				
5270.0	38.677	38.477	38.878		38.878	38.477		
5310.0	38.677	38.477	38.878		38.878	38.477		

Test Frequency	Measured 99% Bandwidth (MHz)				99% Bandwidth (MHz)			
	Port(s)				Highest	Lowest		
MHz	a	b	c	d				
5270.0	36.273	36.273	36.273		36.273	36.273		
5310.0	36.273	36.273	36.473		36.473	36.273		

Traceability to Industry Recognized Test Methodologies

Work Instruction:	WI-03 MEASURING RF SPECTRUM MASK
Measurement Uncertainty:	±2.81 dB

Note: click the links in the above matrix to view the graphical image (plot).

This test report may be reproduced in full only. The document may only be updated by MiCOM Labs personnel. Any changes will be noted in the Document History section of the report.



Title: Aruba Networks APIN0214, APIN0215
To: FCC 47 CFR Part 15.407 & IC RSS-210
Serial #: ARUB179-U8 Rev B
Issue Date: 2nd September 2014
Page: 37 of 330

Equipment Configuration for 26 dB & 99% Occupied Bandwidth

Variant:	802.11a	Duty Cycle (%):	90
Data Rate:	6 MBit/s	Antenna Gain (dBi):	Not Applicable
Modulation:	OFDM	Beam Forming Gain (Y):	Not Applicable
TPC:	Not Applicable	Tested By:	SB
Engineering Test Notes: Image built 2014-05-07 at 04:01:39 EDT (gcc version 4.5.1)			

Test Measurement Results

Test Frequency	Measured 26 dB Bandwidth (MHz)				26 dB Bandwidth (MHz)			
	Port(s)				Highest	Lowest		
MHz	a	b	c	d	Highest	Lowest		
5500.0	19.940	19.238	19.840		19.940	19.238		
5580.0	19.840	19.238	19.840		19.840	19.238		
5720.0	20.040	19.339	19.940		20.040	19.339		

Test Frequency	Measured 99% Bandwidth (MHz)				99% Bandwidth (MHz)			
	Port(s)				Highest	Lowest		
MHz	a	b	c	d	Highest	Lowest		
5500.0	16.633	16.533	16.533		16.633	16.533		
5580.0	16.633	16.533	16.533		16.633	16.533		
5720.0	16.633	16.433	16.533		16.633	16.433		

Traceability to Industry Recognized Test Methodologies

Work Instruction:	WI-03 MEASURING RF SPECTRUM MASK
Measurement Uncertainty:	±2.81 dB

Note: click the links in the above matrix to view the graphical image (plot).

This test report may be reproduced in full only. The document may only be updated by MiCOM Labs personnel. Any changes will be noted in the Document History section of the report.



Title: Aruba Networks APIN0214, APIN0215
To: FCC 47 CFR Part 15.407 & IC RSS-210
Serial #: ARUB179-U8 Rev B
Issue Date: 2nd September 2014
Page: 38 of 330

Equipment Configuration for 26 dB & 99% Occupied Bandwidth

Variant:	802.11ac-80	Duty Cycle (%):	90
Data Rate:	27.5 MBit/s	Antenna Gain (dBi):	Not Applicable
Modulation:	OFDM	Beam Forming Gain (Y):	Not Applicable
TPC:	Not Applicable	Tested By:	SB
Engineering Test Notes:	Image built 2014-05-07 at 04:01:39 EDT (gcc version 4.5.1)		

Test Measurement Results

Test Frequency	Measured 26 dB Bandwidth (MHz)				26 dB Bandwidth (MHz)			
	Port(s)				Highest	Lowest		
MHz	a	b	c	d	Highest	Lowest		
5530.0	80.160	79.760	80.160		80.160	79.760		
5690.0	80.160	79.760	80.160		80.160	79.760		

Test Frequency	Measured 99% Bandwidth (MHz)				99% Bandwidth (MHz)			
	Port(s)				Highest	Lowest		
MHz	a	b	c	d	Highest	Lowest		
5530.0	75.752	75.752	75.752		75.752	75.752		
5690.0	75.752	75.752	75.752		75.752	75.752		

Traceability to Industry Recognized Test Methodologies

Work Instruction:	WI-03 MEASURING RF SPECTRUM MASK
Measurement Uncertainty:	±2.81 dB

Note: click the links in the above matrix to view the graphical image (plot).

This test report may be reproduced in full only. The document may only be updated by MiCOM Labs personnel. Any changes will be noted in the Document History section of the report.



Title: Aruba Networks APIN0214, APIN0215
To: FCC 47 CFR Part 15.407 & IC RSS-210
Serial #: ARUB179-U8 Rev B
Issue Date: 2nd September 2014
Page: 39 of 330

Equipment Configuration for 26 dB & 99% Occupied Bandwidth

Variant:	802.11n HT-20	Duty Cycle (%):	85
Data Rate:	6.5 MBit/s	Antenna Gain (dBi):	Not Applicable
Modulation:	OFDM	Beam Forming Gain (Y):	Not Applicable
TPC:	Not Applicable	Tested By:	SB
Engineering Test Notes: Image built 2014-05-07 at 04:01:39 EDT (gcc version 4.5.1)			

Test Measurement Results

Test Frequency	Measured 26 dB Bandwidth (MHz)				26 dB Bandwidth (MHz)			
	Port(s)				Highest	Lowest		
MHz	a	b	c	d				
5500.0	19.940	19.238	19.439		19.940	19.238		
5580.0	19.940	19.339	19.439		19.940	19.339		
5720.0	19.339	19.339	19.539		19.539	19.339		

Test Frequency	Measured 99% Bandwidth (MHz)				99% Bandwidth (MHz)			
	Port(s)				Highest	Lowest		
MHz	a	b	c	d				
5500.0	16.633	16.533	16.533		16.633	16.533		
5580.0	16.633	16.533	16.533		16.633	16.533		
5720.0	16.533	16.533	16.533		16.533	16.533		

Traceability to Industry Recognized Test Methodologies

Work Instruction:	WI-03 MEASURING RF SPECTRUM MASK
Measurement Uncertainty:	±2.81 dB

Note: click the links in the above matrix to view the graphical image (plot).

This test report may be reproduced in full only. The document may only be updated by MiCOM Labs personnel. Any changes will be noted in the Document History section of the report.



Title: Aruba Networks APIN0214, APIN0215
To: FCC 47 CFR Part 15.407 & IC RSS-210
Serial #: ARUB179-U8 Rev B
Issue Date: 2nd September 2014
Page: 40 of 330

Equipment Configuration for 26 dB & 99% Occupied Bandwidth

Variant:	802.11n HT-40	Duty Cycle (%):	90
Data Rate:	13.5 MBit/s	Antenna Gain (dBi):	Not Applicable
Modulation:	OFDM	Beam Forming Gain (Y):	Not Applicable
TPC:	Not Applicable	Tested By:	SB
Engineering Test Notes: Image built 2014-05-07 at 04:01:39 EDT (gcc version 4.5.1)			

Test Measurement Results

Test Frequency	Measured 26 dB Bandwidth (MHz)				26 dB Bandwidth (MHz)			
	Port(s)				Highest	Lowest		
MHz	a	b	c	d	Highest	Lowest		
5510.0	38.677	38.477	38.878		38.878	38.477		
5550.0	38.677	38.477	38.878		38.878	38.477		
5710.0	38.677	38.477	38.677		38.677	38.477		

Test Frequency	Measured 99% Bandwidth (MHz)				99% Bandwidth (MHz)			
	Port(s)				Highest	Lowest		
MHz	a	b	c	d	Highest	Lowest		
5510.0	36.273	36.273	36.473		36.473	36.273		
5550.0	36.273	36.273	36.473		36.473	36.273		
5710.0	36.473	36.273	36.473		36.473	36.273		

Traceability to Industry Recognized Test Methodologies

Work Instruction:	WI-03 MEASURING RF SPECTRUM MASK
Measurement Uncertainty:	±2.81 dB

Note: click the links in the above matrix to view the graphical image (plot).

This test report may be reproduced in full only. The document may only be updated by MiCOM Labs personnel. Any changes will be noted in the Document History section of the report.



Title: Aruba Networks APIN0214, APIN0215
To: FCC 47 CFR Part 15.407 & IC RSS-210
Serial #: ARUB179-U8 Rev B
Issue Date: 2nd September 2014
Page: 41 of 330

Specification

Limits

FCC, Part 15 §15.407 (a)(1), (a)(2) and Industry Canada RSS-210 § A9.2(2)

(a)(1) For the band 5.15-5.25 GHz the maximum conducted output power over the frequency band of operation shall not exceed the lesser of 50 mW or $+4 \text{ dBm} + 10 \log B$, where B is the 26 dB emission bandwidth in megahertz. In addition, the peak power spectral density shall not exceed +4 dBm in any 1 megahertz band.

(a)(2) For the 5.25-5.35 GHz band the maximum conducted output power over the frequency band of operation shall not exceed the lesser of 250 mW or $+11 \text{ dBm} + 10 \log B$, where B is the 26 dB emission bandwidth in megahertz. In addition, the peak power spectral density shall not exceed +11 dBm in any 1 megahertz band.

Industry Canada RSS-Gen 4.4

When an occupied bandwidth value is not specified in the applicable RSS, the transmitted signal bandwidth to be reported is to be its 99% emission bandwidth, as calculated or measured.

This test report may be reproduced in full only. The document may only be updated by MiCOM Labs personnel. Any changes will be noted in the Document History section of the report.



Title: Aruba Networks APIN0214, APIN0215
To: FCC 47 CFR Part 15.407 & IC RSS-210
Serial #: ARUB179-U8 Rev B
Issue Date: 2nd September 2014
Page: 42 of 330

6.1.1.2. Conducted Output Power

Conducted Test Conditions for Maximum Conducted Output Power			
Standard:	FCC CFR 47:15.407	Ambient Temp. (°C):	24.0 - 27.5
Test Heading:	Maximum Conducted Output Power	Rel. Humidity (%):	32 - 45
Standard Section(s):	15.407 (a)	Pressure (mBars):	999 - 1001
Reference Document(s):	KDB 789033 - D01 DTS General UNII Test Procedures v01		

Test Procedure for Maximum Conducted Output Power Measurement

Method PM (Measurement using an RF average power meter). Section C) 4) of KDB 789033 defines a methodology using an average wideband power meter. Measurements were made while the EUT was operating in a continuous transmission mode (100% duty cycle) at the appropriate center frequency. All cable losses and offsets were taken into consideration in the measured result. All operational modes and frequency bands were measured independently and the resultant \square calculated. For multiple outputs, the measurements were made simultaneously on each output port and summed in a linear fashion. This technique was used in order to prove compliance.

This test report may be reproduced in full only. The document may only be updated by MiCOM Labs personnel. Any changes will be noted in the Document History section of the report.



Antenna Beam and Non-Beam Forming Power Levels

15. 407 (a)(1), (a) (2) Operation with directional antenna gains greater than 6 dBi.

If transmitting antennas of directional gain greater than 6 dBi are used, the conducted output power from the intentional radiator shall be reduced by the amount in dB that the directional gain of the antenna exceeds 6 dBi. Further FCC KDB 662911 D01 Multiple Transmitter Output v01 requires that the gain of antennas transmitting the same data (legacy 802.11a mode) must be increased by $10 * \log(N)$ when N is the number of antenna elements.

Maximum Transmit (Conducted) Power, FCC Limits and Industry Canada Limits

FCC Limits

Bands 5250 – 5350 and 5470 – 5725 MHz

Limit lesser of: 250 mW or $11 \text{ dBm} + 10 \log(B) \text{ dBm}$

Mode	Frequency Range (MHz)	Maximum 26 dB Bandwidth (MHz)	11 + 10 Log (B) (dBm)	Limit (dBm)
a	5250 – 5350	20.04	+24.01	+24.0
HT-20		19.9	+24.00	+24.0
HT-40	5470 – 5725	38.9	+26.90	+24.0
ac-80		80.2	+30.04	+24.0

Industry Canada Limits

Bands 5250 – 5350 and 5470 – 5725 MHz

Limit lesser of: 200 mW or $10 \text{ dBm} + 10 \log(B) \text{ dBm}$

Mode	Frequency Range (MHz)	Maximum 99% Bandwidth (MHz)	11 + 10 Log (B) (dBm)	Limit (dBm)
a	5250 – 5350	16.6	+22.20	+22.2
HT-20		16.6	+22.20	+22.2
HT-40	5470 – 5725	36.5	+25.62	+23.0
ac-80		75.8	+28.80	+23.0

The APIN0215 does not implement beam-forming



Title: Aruba Networks APIN0214, APIN0215
To: FCC 47 CFR Part 15.407 & IC RSS-210
Serial #: ARUB179-U8 Rev B
Issue Date: 2nd September 2014
Page: 44 of 330

Equipment Configuration for Peak Transmit Power			
Variant:	802.11a	Duty Cycle (%):	90
Data Rate:	6 MBit/s	Antenna Gain (dBi):	2.00
Modulation:	OFDM	Beam Forming Gain (Y):	N/A
TPC:	Not Applicable	Tested By:	SB
Engineering Test Notes: Image built 2014-05-07 at 04:01:39 EDT (gcc version 4.5.1)			

Test Measurement Results									
Test Frequency	Measured Conducted Output Power (dBm)				Calculated Total Power	Minimum 26 dB Bandwidth	Limit	Margin	EUT Power Setting
	Port(s)								
MHz	a	b	c	d	Σ Port(s) dBm	MHz	dBm	dBm	
5260.0	16.75	17.23	16.58		21.63	19.238	23.84	-2.21	20.00
5300.0	16.85	17.37	16.87		21.81	19.238	23.84	-2.04	20.00
5320.0	16.97	17.57	16.99		21.95	19.038	23.80	-1.84	20.00

Traceability to Industry Recognized Test Methodologies	
Work Instruction:	WI-03 MEASURING RF SPECTRUM MASK
Measurement Uncertainty:	± 2.81 dB

This test report may be reproduced in full only. The document may only be updated by MiCOM Labs personnel. Any changes will be noted in the Document History section of the report.



Title: Aruba Networks APIN0214, APIN0215
To: FCC 47 CFR Part 15.407 & IC RSS-210
Serial #: ARUB179-U8 Rev B
Issue Date: 2nd September 2014
Page: 45 of 330

Equipment Configuration for Peak Transmit Power

Variant:	802.11ac-80	Duty Cycle (%):	90
Data Rate:	27.5 MBit/s	Antenna Gain (dBi):	2.00
Modulation:	OFDM	Beam Forming Gain (Y):	N/A
TPC:	Not Applicable	Tested By:	SB
Engineering Test Notes:	Image built 2014-05-07 at 04:01:39 EDT (gcc version 4.5.1)		

Test Measurement Results

Test Frequency	Measured Conducted Output Power (dBm)				Calculated Total Power Σ Port(s) dBm	Minimum 26 dB Bandwidth MHz	Limit dBm	Margin dBm	EUT Power Setting
	a	b	c	d					
5290.0	16.79	17.44	17.14		21.90	79.760	24.00	-2.10	20.00

Traceability to Industry Recognized Test Methodologies

Work Instruction:	WI-03 MEASURING RF SPECTRUM MASK
Measurement Uncertainty:	±2.81 dB

This test report may be reproduced in full only. The document may only be updated by MiCOM Labs personnel. Any changes will be noted in the Document History section of the report.



Title: Aruba Networks APIN0214, APIN0215
To: FCC 47 CFR Part 15.407 & IC RSS-210
Serial #: ARUB179-U8 Rev B
Issue Date: 2nd September 2014
Page: 46 of 330

Equipment Configuration for Peak Transmit Power

Variant:	802.11n HT-20	Duty Cycle (%):	85
Data Rate:	6.5 MBit/s	Antenna Gain (dBi):	2.00
Modulation:	OFDM	Beam Forming Gain (Y):	N/A
TPC:	Not Applicable	Tested By:	SB
Engineering Test Notes:	Image built 2014-05-07 at 04:01:39 EDT (gcc version 4.5.1)		

Test Measurement Results

Test Frequency	Measured Conducted Output Power (dBm)				Calculated Total Power Σ Port(s) dBm	Minimum 26 dB Bandwidth MHz	Limit dBm	Margin dBm	EUT Power Setting
	a	b	c	d					
5260.0	16.98	17.68	16.97		21.99	19.038	23.80	-1.81	20.00
5300.0	17.32	17.79	17.31		22.25	18.938	23.77	-1.53	20.00
5320.0	17.43	18.01	17.41		22.39	18.838	23.75	-1.36	20.00

Traceability to Industry Recognized Test Methodologies

Work Instruction:	WI-03 MEASURING RF SPECTRUM MASK
Measurement Uncertainty:	±2.81 dB

This test report may be reproduced in full only. The document may only be updated by MiCOM Labs personnel. Any changes will be noted in the Document History section of the report.



Title: Aruba Networks APIN0214, APIN0215
To: FCC 47 CFR Part 15.407 & IC RSS-210
Serial #: ARUB179-U8 Rev B
Issue Date: 2nd September 2014
Page: 47 of 330

Equipment Configuration for Peak Transmit Power

Variant:	802.11n HT-40	Duty Cycle (%):	90
Data Rate:	13.5 MBit/s	Antenna Gain (dBi):	2.00
Modulation:	OFDM	Beam Forming Gain (Y):	N/A
TPC:	Not Applicable	Tested By:	SB
Engineering Test Notes:	Image built 2014-05-07 at 04:01:39 EDT (gcc version 4.5.1)		

Test Measurement Results

Test Frequency	Measured Conducted Output Power (dBm)				Calculated Total Power Σ Port(s) dBm	Minimum 26 dB Bandwidth MHz	Limit dBm	Margin dBm	EUT Power Setting
	a	b	c	d					
5270.0	16.50	17.39	16.63		21.63	38.477	24.00	-2.37	20.00
5310.0	16.85	17.71	17.01		21.98	38.477	24.00	-2.02	20.00

Traceability to Industry Recognized Test Methodologies

Work Instruction:	WI-03 MEASURING RF SPECTRUM MASK
Measurement Uncertainty:	±2.81 dB

This test report may be reproduced in full only. The document may only be updated by MiCOM Labs personnel. Any changes will be noted in the Document History section of the report.



Title: Aruba Networks APIN0214, APIN0215
To: FCC 47 CFR Part 15.407 & IC RSS-210
Serial #: ARUB179-U8 Rev B
Issue Date: 2nd September 2014
Page: 48 of 330

Equipment Configuration for Peak Transmit Power

Variant:	802.11a	Duty Cycle (%):	90
Data Rate:	6 MBit/s	Antenna Gain (dBi):	2.00
Modulation:	OFDM	Beam Forming Gain (Y):	N/A
TPC:	Not Applicable	Tested By:	SB
Engineering Test Notes: Image built 2014-05-07 at 04:01:39 EDT (gcc version 4.5.1)			

Test Measurement Results									
Test Frequency	Measured Conducted Output Power (dBm)				Calculated Total Power	Minimum 26 dB Bandwidth	Limit	Margin	EUT Power Setting
	Port(s)								
MHz	a	b	c	d	Σ Port(s) dBm	MHz	dBm	dBm	
5500.0	16.76	17.98	16.76		21.97	19.238	23.84	-1.87	20.00
5580.0	16.81	18.08	16.41		21.93	19.238	23.84	-1.91	20.00
5720.0	16.02	17.88	16.49		21.64	19.339	23.86	-2.23	20.00

Traceability to Industry Recognized Test Methodologies	
Work Instruction:	WI-03 MEASURING RF SPECTRUM MASK
Measurement Uncertainty:	±2.81 dB

This test report may be reproduced in full only. The document may only be updated by MiCOM Labs personnel. Any changes will be noted in the Document History section of the report.



Title: Aruba Networks APIN0214, APIN0215
To: FCC 47 CFR Part 15.407 & IC RSS-210
Serial #: ARUB179-U8 Rev B
Issue Date: 2nd September 2014
Page: 49 of 330

Equipment Configuration for Peak Transmit Power

Variant:	802.11ac-80	Duty Cycle (%):	90
Data Rate:	27.5 MBit/s	Antenna Gain (dBi):	2.00
Modulation:	OFDM	Beam Forming Gain (Y):	N/A
TPC:	Not Applicable	Tested By:	SB
Engineering Test Notes:	Image built 2014-05-07 at 04:01:39 EDT (gcc version 4.5.1)		

Test Measurement Results

Test Frequency	Measured Conducted Output Power (dBm)				Calculated Total Power Σ Port(s) dBm	Minimum 26 dB Bandwidth MHz	Limit dBm	Margin dBm	EUT Power Setting
	a	b	c	d					
5530.0	16.59	18.06	17.14		22.07	79.760	24.00	-1.93	20.00
5690.0	16.08	17.98	16.99		21.85	79.760	24.00	-2.15	20.00

Traceability to Industry Recognized Test Methodologies

Work Instruction:	WI-03 MEASURING RF SPECTRUM MASK
Measurement Uncertainty:	±2.81 dB

This test report may be reproduced in full only. The document may only be updated by MiCOM Labs personnel. Any changes will be noted in the Document History section of the report.



Title: Aruba Networks APIN0214, APIN0215
To: FCC 47 CFR Part 15.407 & IC RSS-210
Serial #: ARUB179-U8 Rev B
Issue Date: 2nd September 2014
Page: 50 of 330

Equipment Configuration for Peak Transmit Power

Variant:	802.11n HT-20	Duty Cycle (%):	85
Data Rate:	6.5 MBit/s	Antenna Gain (dBi):	2.00
Modulation:	OFDM	Beam Forming Gain (Y):	N/A
TPC:	Not Applicable	Tested By:	SB
Engineering Test Notes:	Image built 2014-05-07 at 04:01:39 EDT (gcc version 4.5.1)		

Test Measurement Results

Test Frequency	Measured Conducted Output Power (dBm)				Calculated Total Power Σ Port(s) dBm	Minimum 26 dB Bandwidth MHz	Limit dBm	Margin dBm	EUT Power Setting
	a	b	c	d					
5500.0	17.17	18.31	17.37		22.41	19.238	23.84	-1.43	20.00
5580.0	17.27	18.44	16.87		22.35	19.339	23.86	-1.52	20.00
5720.0	16.44	18.08	16.89		21.96	19.339	23.86	-1.90	20.00

Traceability to Industry Recognized Test Methodologies

Work Instruction:	WI-03 MEASURING RF SPECTRUM MASK
Measurement Uncertainty:	±2.81 dB

This test report may be reproduced in full only. The document may only be updated by MiCOM Labs personnel. Any changes will be noted in the Document History section of the report.



Title: Aruba Networks APIN0214, APIN0215
To: FCC 47 CFR Part 15.407 & IC RSS-210
Serial #: ARUB179-U8 Rev B
Issue Date: 2nd September 2014
Page: 51 of 330

Equipment Configuration for Peak Transmit Power

Variant:	802.11n HT-40	Duty Cycle (%):	90
Data Rate:	13.5 MBit/s	Antenna Gain (dBi):	2.00
Modulation:	OFDM	Beam Forming Gain (Y):	N/A
TPC:	Not Applicable	Tested By:	SB
Engineering Test Notes:	Image built 2014-05-07 at 04:01:39 EDT (gcc version 4.5.1)		

Test Measurement Results

Test Frequency	Measured Conducted Output Power (dBm)				Calculated Total Power Σ Port(s) dBm	Minimum 26 dB Bandwidth MHz	Limit dBm	Margin dBm	EUT Power Setting
	a	b	c	d					
5510.0	16.75	18.16	16.83		22.07	38.477	24.00	-1.93	20.00
5550.0	16.61	18.12	16.62		21.95	38.477	24.00	-2.05	20.00
5710.0	15.99	17.84	16.39		21.58	38.477	24.00	-2.42	20.00

Traceability to Industry Recognized Test Methodologies

Work Instruction:	WI-03 MEASURING RF SPECTRUM MASK
Measurement Uncertainty:	±2.81 dB

This test report may be reproduced in full only. The document may only be updated by MiCOM Labs personnel. Any changes will be noted in the Document History section of the report.



Antenna Type V's Power Setting

The following **Antenna Types V's Power Setting** tables consolidates the results of all testing (conducted output power, radiated spurious and radiated band-edge emissions) performed on the APIN0214 and APIN0215 to finalize power settings for each antenna tested;

Integral Antenna (APIN0215)

Channel	5.25-5.35 GHz				5.47-5.725 GHz			
	a	HT-20	HT-40	ac-80	a	HT-20	HT-40	ac-80
Low	20.0	20.0	20.0	--	20.0	20.0	20.0	16.5
Mid	20.0	20.0	--	13.0	20.0	20.0	20.0	--
High	17.0	17.0	15.75	--	20.0	20.0	20.0	20.0

Antenna AP-ANT-1B (APIN0214)

Channel	5.25-5.35 GHz				5.47-5.725 GHz			
	a	HT-20	HT-40	ac-80	a	HT-20	HT-40	ac-80
Low	20.0	20.0	20.0	--	20.0	20.0	20.0	16.0
Mid	20.0	20.0	--	17.25	20.0	20.0	20.0	--
High	20.0	20.0	20.0	--	20.0	20.0	20.0	20.0

Antenna AP-ANT-13B (APIN0214)

Channel	5.25-5.35 GHz				5.47-5.725 GHz			
	a	HT-20	HT-40	ac-80	a	HT-20	HT-40	ac-80
Low	20.0	20.0	20.0	--	20.0	20.0	20.0	15.0
Mid	20.0	20.0	--	16.5	20.0	20.0	20.0	--
High	20.0	20.0	20.0	--	20.0	20.0	20.0	20.0

Antenna AP-ANT-16 (APIN0214)

Channel	5.25-5.35 GHz				5.47-5.725 GHz			
	a	HT-20	HT-40	ac-80	a	HT-20	HT-40	ac-80
Low	20.0	20.0	20.0	--	20.0	20.0	20.0	20.0
Mid	20.0	20.0	--	20.0	20.0	20.0	20.0	--
High	20.0	20.0	20.0	--	20.0	20.0	20.0	20.0

Antenna AP-ANT-18 (APIN0214)

Channel	5.25-5.35 GHz				5.47-5.725 GHz			
	a	HT-20	HT-40	ac-80	a	HT-20	HT-40	ac-80
Low	20.0	20.0	20.0	--	20.0	20.0	20.0	20.0
Mid	20.0	20.0	--	17.0	20.0	20.0	20.0	--
High	20.0	20.0	20.0	--	20.0	20.0	20.0	20.0

Antenna AP-ANT-19 (APIN0214)

Channel	5.25-5.35 GHz				5.47-5.725 GHz			
	a	HT-20	HT-40	ac-80	a	HT-20	HT-40	ac-80
Low	20.0	20.0	20.0	--	20.0	20.0	20.0	14.0
Mid	20.0	20.0	--	16.75	20.0	20.0	20.0	--
High	17.0	17.0	16.75	--	20.0	20.0	20.0	20.0

This test report may be reproduced in full only. The document may only be updated by MiCOM Labs personnel. Any changes will be noted in the Document History section of the report.



Title: Aruba Networks APIN0214, APIN0215
To: FCC 47 CFR Part 15.407 & IC RSS-210
Serial #: ARUB179-U8 Rev B
Issue Date: 2nd September 2014
Page: 53 of 330

Specification Limits

FCC, Part 15 §15.407 (a)(1), (a)(2) and Industry Canada RSS-210 § A9.2(2)

(a)(1) For the band 5.15-5.25 GHz the maximum conducted output power over the frequency band of operation shall not exceed the lesser of 50 mW or $+4 \text{ dBm} + 10 \log B$, where B is the 26 dB emission bandwidth in megahertz. In addition, the peak power spectral density shall not exceed +4 dBm in any 1 megahertz band.

(a)(2) For the 5.25-5.35 and 5470-5725 MHz GHz band the maximum conducted output power over the frequency band of operation shall not exceed the lesser of 250 mW or $+11 \text{ dBm} + 10 \log B$, where B is the 26 dB emission bandwidth in megahertz. In addition, the peak power spectral density shall not exceed +11 dBm in any 1 megahertz band.

Industry Canada RSS-210 §A9.2(2)

For the band 5150-5250 MHz, the maximum equivalent isotropically radiated power (e.i.r.p.) shall not exceed 200 mW or $10 + 10 \log_{10} B$, dBm, whichever power is less. B is the 99% emission bandwidth in MHz. The e.i.r.p. spectral density shall not exceed 10 dBm in any 1.0 MHz band.

For the band 5250-5350 MHz and 5470-5725 MHz, the maximum conducted output power shall not exceed 250 mW or $11 + 10 \log_{10} B$, dBm, whichever power is less. The power spectral density shall not exceed 11 dBm in any 1.0 MHz band. The maximum e.i.r.p. shall not exceed 1.0 W or $17 + 10 \log_{10} B$, dBm, whichever power is less. B is the 99% emission bandwidth in MHz.

This test report may be reproduced in full only. The document may only be updated by MiCOM Labs personnel. Any changes will be noted in the Document History section of the report.



Title: Aruba Networks APIN0214, APIN0215
To: FCC 47 CFR Part 15.407 & IC RSS-210
Serial #: ARUB179-U8 Rev B
Issue Date: 2nd September 2014
Page: 54 of 330

6.1.1.3. Peak Power Spectral Density

Conducted Test Conditions for Power Spectral Density			
Standard:	FCC CFR 47:15.407	Ambient Temp. (°C):	24.0 - 27.5
Test Heading:	Power Spectral Density	Rel. Humidity (%):	32 - 45
Standard Section(s):	15.247 (a)	Pressure (mBars):	999 - 1001
Reference Document(s):	KDB 789033 - D01 DTS General UNII Test Procedures v01		
Test Procedure for Power Spectral Density			
The In-Band power spectral density was measured using the measure and sum approach per FCC KDB 662911 (D01 Multiple Transmitter Output v0.)			
<u>Measure and sum the spectra across the outputs.</u> With this technique, spectra are measured at each output of the device at the required resolution bandwidth. The individual spectra are then summed mathematically in linear power units. Unlike in-band power measurements, in which the sum involves a single measured value (output power) from each output, measurements for compliance with PSD limits involve summing entire spectra across corresponding frequency bins on the various outputs. Consistency is maintained for any device with N transmitter outputs to be certain the individual outputs are all aligned with the same span and same number of points. In this instance, the linear power spectrum value within the first spectral bin of output 0 is summed with that in the first spectral bin of output 1, and the first spectral bin of output 2, and so on up to the Nth output to obtain the true value for the first frequency bin of the summed spectrum. The summed spectrum value for each frequency bin is computed in this fashion. These summed spectral values were calculated on a computer, and the results read back into the spectrum analyzer as a data file to produce a representative plot of total spectral power density.			
<u>NOTE:</u>			
It may be observed that spectrum in some plots break the limit line however this in itself does NOT constitute a failure. In all cases a spectrum summation plot is provided in order to prove compliance. A summation plot adds each point on the spectrum analyzer for all antenna chains (assuming a MIMO device) and combines into one single graphical image. A failure occurs only after the summation of all spectrum plots have been summed and are found to be greater than the limit line.			
<u>Supporting Information</u>			
Calculated Power = $A + 10 \log (1/x)$ dBm			
A = Total Power Spectral Density [10 Log10 (10a/10 + 10 b/10 + 10c/10 + 10d/10)]			
x = Duty Cycle			

This test report may be reproduced in full only. The document may only be updated by MiCOM Labs personnel. Any changes will be noted in the Document History section of the report.



Title: Aruba Networks APIN0214, APIN0215
To: FCC 47 CFR Part 15.407 & IC RSS-210
Serial #: ARUB179-U8 Rev B
Issue Date: 2nd September 2014
Page: 55 of 330

Equipment Configuration for Peak Power Spectral Density
--

Variant:	802.11a	Duty Cycle (%):	90.0
Data Rate:	6 MBit/s	Antenna Gain (dBi):	2.00
Modulation:	OFDM	Beam Forming Gain (Y):	Not Applicable
TPC:	Not Applicable	Tested By:	SB
Engineering Test Notes:			

Test Measurement Results

Test Frequency	Measured Power Spectral Density				Amplitude Summation	Limit	Margin
	Port(s) (dBm/MHz)						
	a	b	c	d			
5260.0	4.018	4.735	3.062		7.375	11.0	-3.6
5300.0	5.524	4.560	4.311		8.256	11.0	-2.7
5320.0	4.382	5.294	4.168		7.991	11.0	-3.0

Traceability to Industry Recognized Test Methodologies

Work Instruction:	WI-03 MEASURING RF SPECTRUM MASK
Measurement Uncertainty:	±2.81 dB

Note: click the links in the above matrix to view the graphical image (plot).

This test report may be reproduced in full only. The document may only be updated by MiCOM Labs personnel. Any changes will be noted in the Document History section of the report.



Title: Aruba Networks APIN0214, APIN0215
To: FCC 47 CFR Part 15.407 & IC RSS-210
Serial #: ARUB179-U8 Rev B
Issue Date: 2nd September 2014
Page: 56 of 330

Equipment Configuration for Peak Power Spectral Density

Variant:	802.11ac-80	Duty Cycle (%):	90.0
Data Rate:	27.5 MBit/s	Antenna Gain (dBi):	2.00
Modulation:	OFDM	Beam Forming Gain (Y):	Not Applicable
TPC:	Not Applicable	Tested By:	SB
Engineering Test Notes:			

Test Measurement Results

Test Frequency	Measured Power Spectral Density				Amplitude Summation	Limit	Margin
	Port(s) (dBm/MHz)						
MHz	a	b	c	d	dBm/MHz	dBm/MHz	dB
5290.0	-1.505	-0.418	-2.230		2.117	11.0	-8.9

Traceability to Industry Recognized Test Methodologies

Work Instruction:	WI-03 MEASURING RF SPECTRUM MASK
Measurement Uncertainty:	±2.81 dB

Note: click the links in the above matrix to view the graphical image (plot).

This test report may be reproduced in full only. The document may only be updated by MiCOM Labs personnel. Any changes will be noted in the Document History section of the report.



Title: Aruba Networks APIN0214, APIN0215
To: FCC 47 CFR Part 15.407 & IC RSS-210
Serial #: ARUB179-U8 Rev B
Issue Date: 2nd September 2014
Page: 57 of 330

Equipment Configuration for Peak Power Spectral Density
--

Variant:	802.11n HT-20	Duty Cycle (%):	84.6
Data Rate:	6.5 MBit/s	Antenna Gain (dBi):	2.00
Modulation:	OFDM	Beam Forming Gain (Y):	Not Applicable
TPC:	Not Applicable	Tested By:	SB
Engineering Test Notes:			

Test Measurement Results

Test Frequency	Measured Power Spectral Density				Amplitude Summation	Limit	Margin
	Port(s) (dBm/MHz)						
	a	b	c	d			
MHz	a	b	c	d	dBm/MHz	dBm/MHz	dB
5260.0	4.021	5.136	5.659		8.241	11.0	-2.8
5300.0	4.898	6.298	4.548		8.509	11.0	-2.5
5320.0	4.587	6.269	5.785		8.416	11.0	-2.6

Traceability to Industry Recognized Test Methodologies

Work Instruction:	WI-03 MEASURING RF SPECTRUM MASK
Measurement Uncertainty:	±2.81 dB

Note: click the links in the above matrix to view the graphical image (plot).

This test report may be reproduced in full only. The document may only be updated by MiCOM Labs personnel. Any changes will be noted in the Document History section of the report.



Title: Aruba Networks APIN0214, APIN0215
To: FCC 47 CFR Part 15.407 & IC RSS-210
Serial #: ARUB179-U8 Rev B
Issue Date: 2nd September 2014
Page: 58 of 330

Equipment Configuration for Peak Power Spectral Density
--

Variant:	802.11n HT-40	Duty Cycle (%):	90.0
Data Rate:	13.5 MBit/s	Antenna Gain (dBi):	2.00
Modulation:	OFDM	Beam Forming Gain (Y):	Not Applicable
TPC:	Not Applicable	Tested By:	SB
Engineering Test Notes:			

Test Measurement Results

Test Frequency	Measured Power Spectral Density				Amplitude Summation	Limit	Margin
	Port(s) (dBm/MHz)						
	a	b	c	d			
MHz					dBm/MHz	dBm/MHz	dB
5270.0	1.528	2.129	0.113		4.799	11.0	-6.2
5310.0	0.334	2.984	0.512		5.337	11.0	-5.7

Traceability to Industry Recognized Test Methodologies

Work Instruction:	WI-03 MEASURING RF SPECTRUM MASK
Measurement Uncertainty:	±2.81 dB

Note: click the links in the above matrix to view the graphical image (plot).

This test report may be reproduced in full only. The document may only be updated by MiCOM Labs personnel. Any changes will be noted in the Document History section of the report.



Title: Aruba Networks APIN0214, APIN0215
To: FCC 47 CFR Part 15.407 & IC RSS-210
Serial #: ARUB179-U8 Rev B
Issue Date: 2nd September 2014
Page: 59 of 330

Equipment Configuration for Peak Power Spectral Density
--

Variant:	802.11a	Duty Cycle (%):	90.0
Data Rate:	6 MBit/s	Antenna Gain (dBi):	2.00
Modulation:	OFDM	Beam Forming Gain (Y):	Not Applicable
TPC:	Not Applicable	Tested By:	SB
Engineering Test Notes:			

Test Measurement Results

Test Frequency	Measured Power Spectral Density				Amplitude Summation	Limit	Margin
	Port(s) (dBm/MHz)						
	a	b	c	d			
5500.0	3.753	5.460	3.626		7.489	11.0	-3.5
5580.0	4.417	4.543	3.470		7.658	11.0	-3.3
5720.0	2.461	4.185	3.030		7.000	11.0	-4.0

Traceability to Industry Recognized Test Methodologies

Work Instruction:	WI-03 MEASURING RF SPECTRUM MASK
Measurement Uncertainty:	±2.81 dB

Note: click the links in the above matrix to view the graphical image (plot).

This test report may be reproduced in full only. The document may only be updated by MiCOM Labs personnel. Any changes will be noted in the Document History section of the report.



Title: Aruba Networks APIN0214, APIN0215
To: FCC 47 CFR Part 15.407 & IC RSS-210
Serial #: ARUB179-U8 Rev B
Issue Date: 2nd September 2014
Page: 60 of 330

Equipment Configuration for Peak Power Spectral Density
--

Variant:	802.11ac-80	Duty Cycle (%):	90.0
Data Rate:	27.5 MBit/s	Antenna Gain (dBi):	2.00
Modulation:	OFDM	Beam Forming Gain (Y):	Not Applicable
TPC:	Not Applicable	Tested By:	SB
Engineering Test Notes:			

Test Measurement Results

Test Frequency	Measured Power Spectral Density				Amplitude Summation	Limit	Margin
	Port(s) (dBm/MHz)						
	a	b	c	d			
5530.0	-2.479	-0.803	-2.351		1.656	11.0	-9.3
5690.0	-2.935	-0.974	-1.611		1.752	11.0	-9.2

Traceability to Industry Recognized Test Methodologies

Work Instruction:	WI-03 MEASURING RF SPECTRUM MASK
Measurement Uncertainty:	±2.81 dB

Note: click the links in the above matrix to view the graphical image (plot).

This test report may be reproduced in full only. The document may only be updated by MiCOM Labs personnel. Any changes will be noted in the Document History section of the report.



Title: Aruba Networks APIN0214, APIN0215
To: FCC 47 CFR Part 15.407 & IC RSS-210
Serial #: ARUB179-U8 Rev B
Issue Date: 2nd September 2014
Page: 61 of 330

Equipment Configuration for Peak Power Spectral Density
--

Variant:	802.11n HT-20	Duty Cycle (%):	84.6
Data Rate:	6.5 MBit/s	Antenna Gain (dBi):	2.00
Modulation:	OFDM	Beam Forming Gain (Y):	Not Applicable
TPC:	Not Applicable	Tested By:	SB
Engineering Test Notes:			

Test Measurement Results							
---------------------------------	--	--	--	--	--	--	--

Test Frequency	Measured Power Spectral Density				Amplitude Summation	Limit	Margin
	Port(s) (dBm/MHz)						
	a	b	c	d			
MHz					dBm/MHz	dBm/MHz	dB
5500.0	5.576	5.478	4.629		8.362	11.0	-2.6
5580.0	4.365	6.097	5.169		8.264	11.0	-2.7
5720.0	3.893	5.085	3.880		7.475	11.0	-3.5

Traceability to Industry Recognized Test Methodologies	
---	--

Work Instruction:	WI-03 MEASURING RF SPECTRUM MASK
Measurement Uncertainty:	±2.81 dB

Note: click the links in the above matrix to view the graphical image (plot).

This test report may be reproduced in full only. The document may only be updated by MiCOM Labs personnel. Any changes will be noted in the Document History section of the report.



Title: Aruba Networks APIN0214, APIN0215
To: FCC 47 CFR Part 15.407 & IC RSS-210
Serial #: ARUB179-U8 Rev B
Issue Date: 2nd September 2014
Page: 62 of 330

Equipment Configuration for Peak Power Spectral Density
--

Variant:	802.11n HT-40	Duty Cycle (%):	90.0
Data Rate:	13.5 MBit/s	Antenna Gain (dBi):	2.00
Modulation:	OFDM	Beam Forming Gain (Y):	Not Applicable
TPC:	Not Applicable	Tested By:	SB
Engineering Test Notes:			

Test Measurement Results

Test Frequency	Measured Power Spectral Density				Amplitude Summation	Limit	Margin
	Port(s) (dBm/MHz)						
	a	b	c	d			
5510.0	0.960	2.009	1.458		4.992	11.0	-6.0
5550.0	0.402	2.316	1.000		4.778	11.0	-6.2
5710.0	0.512	1.430	-0.031		4.516	11.0	-6.5

Traceability to Industry Recognized Test Methodologies

Work Instruction:	WI-03 MEASURING RF SPECTRUM MASK
Measurement Uncertainty:	±2.81 dB

Note: click the links in the above matrix to view the graphical image (plot).

This test report may be reproduced in full only. The document may only be updated by MiCOM Labs personnel. Any changes will be noted in the Document History section of the report.



Title: Aruba Networks APIN0214, APIN0215
To: FCC 47 CFR Part 15.407 & IC RSS-210
Serial #: ARUB179-U8 Rev B
Issue Date: 2nd September 2014
Page: 63 of 330

Specification

FCC, Part 15 §15.407 (a)(1), (a)(2)

5150 – 5250 MHz

(a)(1) The peak power spectral density shall not exceed +4 dBm in any 1 megahertz band.

5250 – 5350 MHz & 5470 – 5725 MHz

(a)(2) The peak power spectral density shall not exceed +11 dBm in any 1 megahertz band.

Industry Canada RSS-210 § A9.2(1), A9.2(2)

5150 – 5250 MHz

§ **A9.2(1)** The eirp spectral density shall not exceed +10 dBm in any 1 MHz band

5250 – 5350 MHz & 5470 – 5725 MHz

§ **A9.2(2)** The power spectral density shall not exceed +11 dBm in any 1 MHz band

This test report may be reproduced in full only. The document may only be updated by MiCOM Labs personnel. Any changes will be noted in the Document History section of the report.



Title: Aruba Networks APIN0214, APIN0215
To: FCC 47 CFR Part 15.407 & IC RSS-210
Serial #: ARUB179-U8 Rev B
Issue Date: 2nd September 2014
Page: 64 of 330

6.1.1.4. Peak Excursion Ratio

Conducted Test Conditions for Peak Excursion Ratio			
Standard:	FCC CFR 47:15.407	Ambient Temp. (°C):	24.0 - 27.5
Test Heading:	Peak Excursion Ratio	Rel. Humidity (%):	32 - 45
Standard Section(s):	15.407 (a)(6)	Pressure (mBars):	999 - 1001
Reference Document(s):	KDB 789033 - D01 DTS General UNII Test Procedures v01		

Test Procedure for Peak Excursion Ratio

Compliance with the peak excursion requirement is demonstrated by confirming the ratio of the maximum of the peak-hold spectrum to the maximum of the average spectrum during continuous transmission. Section F) of KDB 789033 was used in order to prove compliance. This is a conducted measurement using a spectrum analyzer using dual traces. Peak Excursion Ratio is the difference in amplitude (dB) between both traces; The following identifies two spectrum traces on the same plot. Trace 1 is the max hold Peak detector, and Trace 2 is the recalled trace data from Peak Power Spectral Density measurements. Each frequency and operational mode is recalled in order to prove compliance.

This test report may be reproduced in full only. The document may only be updated by MiCOM Labs personnel. Any changes will be noted in the Document History section of the report.



Title: Aruba Networks APIN0214, APIN0215
To: FCC 47 CFR Part 15.407 & IC RSS-210
Serial #: ARUB179-U8 Rev B
Issue Date: 2nd September 2014
Page: 65 of 330

Equipment Configuration for Peak Excursion Ratio

Variant:	802.11a	Duty Cycle (%):	90
Data Rate:	6 MBit/s	Antenna Gain (dBi):	Not Applicable
Modulation:	OFDM	Beam Forming Gain (Y):	Not Applicable
TPC:	Not Applicable	Tested By:	SB
Engineering Test Notes:	Image built 2014-05-07 at 04:01:39 EDT (gcc version 4.5.1)		

Test Measurement Results

Test Frequency	Measured Peak Excursion (dB)				Ratio (dB)		Limit	Lowest Margin
	Port(s)				Highest	Lowest		
MHz	a	b	c	d			dB	MHz
5260.0	10.98				10.98	10.98	13.0	-2.02

Traceability to Industry Recognized Test Methodologies

Work Instruction:	WI-03 MEASURING RF SPECTRUM MASK
Measurement Uncertainty:	±2.81 dB

Note: click the links in the above matrix to view the graphical image (plot).

This test report may be reproduced in full only. The document may only be updated by MiCOM Labs personnel. Any changes will be noted in the Document History section of the report.



Title: Aruba Networks APIN0214, APIN0215
To: FCC 47 CFR Part 15.407 & IC RSS-210
Serial #: ARUB179-U8 Rev B
Issue Date: 2nd September 2014
Page: 66 of 330

Equipment Configuration for Peak Excursion Ratio

Variant:	802.11ac-80	Duty Cycle (%):	90
Data Rate:	27.5 MBit/s	Antenna Gain (dBi):	Not Applicable
Modulation:	OFDM	Beam Forming Gain (Y):	Not Applicable
TPC:	Not Applicable	Tested By:	SB
Engineering Test Notes: Image built 2014-05-07 at 04:01:39 EDT (gcc version 4.5.1)			

Test Measurement Results

Test Frequency	Measured Peak Excursion (dB)				Ratio (dB)		Limit	Lowest Margin
	Port(s)				Highest	Lowest		
MHz	a	b	c	d	Highest	Lowest	dB	MHz
5290.0	10.69				10.69	10.69	13.0	-2.31

Traceability to Industry Recognized Test Methodologies

Work Instruction:	WI-03 MEASURING RF SPECTRUM MASK
Measurement Uncertainty:	±2.81 dB

Note: click the links in the above matrix to view the graphical image (plot).

This test report may be reproduced in full only. The document may only be updated by MiCOM Labs personnel. Any changes will be noted in the Document History section of the report.



Title: Aruba Networks APIN0214, APIN0215
To: FCC 47 CFR Part 15.407 & IC RSS-210
Serial #: ARUB179-U8 Rev B
Issue Date: 2nd September 2014
Page: 67 of 330

Equipment Configuration for Peak Excursion Ratio

Variant:	802.11n HT-20	Duty Cycle (%):	85
Data Rate:	6.5 MBit/s	Antenna Gain (dBi):	Not Applicable
Modulation:	OFDM	Beam Forming Gain (Y):	Not Applicable
TPC:	Not Applicable	Tested By:	SB
Engineering Test Notes: Image built 2014-05-07 at 04:01:39 EDT (gcc version 4.5.1)			

Test Measurement Results

Test Frequency MHz	Measured Peak Excursion (dB)				Ratio (dB)		Limit dB	Lowest Margin MHz
	Port(s)				Highest	Lowest		
	a	b	c	d				
5260.0	11.27				11.27	11.27	13.0	-1.73

Traceability to Industry Recognized Test Methodologies

Work Instruction:	WI-03 MEASURING RF SPECTRUM MASK
Measurement Uncertainty:	±2.81 dB

Note: click the links in the above matrix to view the graphical image (plot).

This test report may be reproduced in full only. The document may only be updated by MiCOM Labs personnel. Any changes will be noted in the Document History section of the report.



Title: Aruba Networks APIN0214, APIN0215
To: FCC 47 CFR Part 15.407 & IC RSS-210
Serial #: ARUB179-U8 Rev B
Issue Date: 2nd September 2014
Page: 68 of 330

Equipment Configuration for Peak Excursion Ratio

Variant:	802.11n HT-40	Duty Cycle (%):	90
Data Rate:	13.5 MBit/s	Antenna Gain (dBi):	Not Applicable
Modulation:	OFDM	Beam Forming Gain (Y):	Not Applicable
TPC:	Not Applicable	Tested By:	SB
Engineering Test Notes: Image built 2014-05-07 at 04:01:39 EDT (gcc version 4.5.1)			

Test Measurement Results

Test Frequency	Measured Peak Excursion (dB)				Ratio (dB)		Limit	Lowest Margin
	Port(s)				Highest	Lowest		
MHz	a	b	c	d	Highest	Lowest	dB	MHz
5270.0	10.59				10.59	10.59	13.0	-2.41

Traceability to Industry Recognized Test Methodologies

Work Instruction:	WI-03 MEASURING RF SPECTRUM MASK
Measurement Uncertainty:	±2.81 dB

Note: click the links in the above matrix to view the graphical image (plot).

This test report may be reproduced in full only. The document may only be updated by MiCOM Labs personnel. Any changes will be noted in the Document History section of the report.



Title: Aruba Networks APIN0214, APIN0215
To: FCC 47 CFR Part 15.407 & IC RSS-210
Serial #: ARUB179-U8 Rev B
Issue Date: 2nd September 2014
Page: 69 of 330

Equipment Configuration for Peak Excursion Ratio

Variant:	802.11a	Duty Cycle (%):	90
Data Rate:	6 MBit/s	Antenna Gain (dBi):	Not Applicable
Modulation:	OFDM	Beam Forming Gain (Y):	Not Applicable
TPC:	Not Applicable	Tested By:	SB
Engineering Test Notes: Image built 2014-05-07 at 04:01:39 EDT (gcc version 4.5.1)			

Test Measurement Results

Test Frequency	Measured Peak Excursion (dB)				Ratio (dB)		Limit	Lowest Margin
	Port(s)				Highest	Lowest		
MHz	a	b	c	d	Highest	Lowest	dB	MHz
5500.0	10.75				10.75	10.75	13.0	-2.25

Traceability to Industry Recognized Test Methodologies

Work Instruction:	WI-03 MEASURING RF SPECTRUM MASK
Measurement Uncertainty:	±2.81 dB

Note: click the links in the above matrix to view the graphical image (plot).

This test report may be reproduced in full only. The document may only be updated by MiCOM Labs personnel. Any changes will be noted in the Document History section of the report.



Title: Aruba Networks APIN0214, APIN0215
To: FCC 47 CFR Part 15.407 & IC RSS-210
Serial #: ARUB179-U8 Rev B
Issue Date: 2nd September 2014
Page: 70 of 330

Equipment Configuration for Peak Excursion Ratio

Variant:	802.11ac-80	Duty Cycle (%):	90
Data Rate:	27.5 MBit/s	Antenna Gain (dBi):	Not Applicable
Modulation:	OFDM	Beam Forming Gain (Y):	Not Applicable
TPC:	Not Applicable	Tested By:	SB
Engineering Test Notes:	Image built 2014-05-07 at 04:01:39 EDT (gcc version 4.5.1)		

Test Measurement Results

Test Frequency	Measured Peak Excursion (dB)				Ratio (dB)		Limit	Lowest Margin
	Port(s)				Highest	Lowest		
MHz	a	b	c	d				
5530.0	12.05				12.05	12.05	13.0	-0.95

Traceability to Industry Recognized Test Methodologies

Work Instruction:	WI-03 MEASURING RF SPECTRUM MASK
Measurement Uncertainty:	±2.81 dB

Note: click the links in the above matrix to view the graphical image (plot).

This test report may be reproduced in full only. The document may only be updated by MiCOM Labs personnel. Any changes will be noted in the Document History section of the report.



Title: Aruba Networks APIN0214, APIN0215
To: FCC 47 CFR Part 15.407 & IC RSS-210
Serial #: ARUB179-U8 Rev B
Issue Date: 2nd September 2014
Page: 71 of 330

Equipment Configuration for Peak Excursion Ratio

Variant:	802.11n HT-20	Duty Cycle (%):	85
Data Rate:	6.5 MBit/s	Antenna Gain (dBi):	Not Applicable
Modulation:	OFDM	Beam Forming Gain (Y):	Not Applicable
TPC:	Not Applicable	Tested By:	SB
Engineering Test Notes:	Image built 2014-05-07 at 04:01:39 EDT (gcc version 4.5.1)		

Test Measurement Results

Test Frequency	Measured Peak Excursion (dB)				Ratio (dB)		Limit	Lowest Margin
	Port(s)				Highest	Lowest		
MHz	a	b	c	d				
5500.0	9.59				9.59	9.59	13.0	-3.41

Traceability to Industry Recognized Test Methodologies

Work Instruction:	WI-03 MEASURING RF SPECTRUM MASK
Measurement Uncertainty:	±2.81 dB

Note: click the links in the above matrix to view the graphical image (plot).

This test report may be reproduced in full only. The document may only be updated by MiCOM Labs personnel. Any changes will be noted in the Document History section of the report.



Title: Aruba Networks APIN0214, APIN0215
To: FCC 47 CFR Part 15.407 & IC RSS-210
Serial #: ARUB179-U8 Rev B
Issue Date: 2nd September 2014
Page: 72 of 330

Equipment Configuration for Peak Excursion Ratio

Variant:	802.11n HT-40	Duty Cycle (%):	90
Data Rate:	13.5 MBit/s	Antenna Gain (dBi):	Not Applicable
Modulation:	OFDM	Beam Forming Gain (Y):	Not Applicable
TPC:	Not Applicable	Tested By:	SB
Engineering Test Notes:	Image built 2014-05-07 at 04:01:39 EDT (gcc version 4.5.1)		

Test Measurement Results

Test Frequency	Measured Peak Excursion (dB)				Ratio (dB)		Limit	Lowest Margin
	Port(s)				Highest	Lowest		
MHz	a	b	c	d			dB	MHz
5510.0	10.46				10.46	10.46	13.0	-2.54

Traceability to Industry Recognized Test Methodologies

Work Instruction:	WI-03 MEASURING RF SPECTRUM MASK
Measurement Uncertainty:	±2.81 dB

Note: click the links in the above matrix to view the graphical image (plot).

This test report may be reproduced in full only. The document may only be updated by MiCOM Labs personnel. Any changes will be noted in the Document History section of the report.



Title: Aruba Networks APIN0214, APIN0215
To: FCC 47 CFR Part 15.407 & IC RSS-210
Serial #: ARUB179-U8 Rev B
Issue Date: 2nd September 2014
Page: 73 of 330

Specification

Limits

§15.407 (a)(6) The ratio of the peak excursion of the modulation envelope (measured using a peak hold function) to the peak transmit power (measured as specified in this paragraph) shall not exceed 13dB across any 1MHz bandwidth or the emission bandwidth whichever is less

This test report may be reproduced in full only. The document may only be updated by MiCOM Labs personnel. Any changes will be noted in the Document History section of the report.



Title: Aruba Networks APIN0214, APIN0215
To: FCC 47 CFR Part 15.407 & IC RSS-210
Serial #: ARUB179-U8 Rev B
Issue Date: 2nd September 2014
Page: 74 of 330

6.1.1.5. Frequency Stability

FCC, Part 15 Subpart C §15.407(g)
Industry Canada RSS-210 §2.1

Test Procedure

The manufacturer of the equipment is responsible for ensuring that the frequency stability is such that emissions are always maintained within the band of operation under all conditions.

Manufacturer Declaration

The frequency stability of the reference oscillator sets the frequency stability of the RF transceiver signals. Therefore all of the RF signals should have ± 20 ppm stability.

This stability accounts for room temp tolerance of the crystal oscillator circuit, frequency variation across temperature, and crystal ageing.

± 20 ppm at 5.250 GHz translates to a maximum frequency shift of ± 105 KHz. As the edge of the channels is at least one MHz from either of the band edges, ± 105 KHz is more than sufficient to guarantee that the intentional emission will remain in the band over the entire operating range of the EUT.

Specification

Limits

§15.407 (g) Manufacturers of U-NII devices are responsible for ensuring frequency stability such that an emission is maintained within the band of operation under all conditions of normal operation as specified in the user's manual.

This test report may be reproduced in full only. The document may only be updated by MiCOM Labs personnel. Any changes will be noted in the Document History section of the report.



6.1.2. Radiated Emission Testing

FCC, Part 15 Subpart C §15.407(b)(2), §15.205(a)/15.209(a)
Industry Canada RSS-210 §A9.3(2); §2.2; §2.6; RSS-Gen §4.7

Test Procedure

Testing was performed in a 3-meter anechoic chamber. Preliminary radiated emissions were measured on every azimuth and with the receiving antenna in both horizontal and vertical polarizations. Preliminary emissions were recorded with in Spectrum Analyzer mode, using a maximum peak detector while in peak hold mode. Depending on the frequency band spanned a notch filter and/or waveguide filter was used to remove the fundamental frequency.

Emissions nearest the limits were chosen for maximization and formal measurement using a CISPR compliant receiver. Emissions above 1000 MHz are measured utilizing a CISPR compliant average detector with a tuned receiver, using a bandwidth of 1 MHz. Emissions from 30 MHz – 1000 MHz are measured utilizing a CISPR compliant quasi-peak detector with a tuned receiver, using a bandwidth of 120 kHz. Only the highest emissions relative to the limit are listed.

Field Strength Calculation

The field strength is calculated by adding the Antenna Factor and Cable Loss, and subtracting Amplifier Gain from the measured reading. All factors are included in the reported data.

$$FS = R + AF + CORR - FO$$

FS = Field Strength

R = Measured Spectrum analyzer Input Amplitude

AF = Antenna Factor

$$CORR = \text{Correction Factor} = CL - AG + NFL$$

CL = Cable Loss

AG = Amplifier Gain

FO = Distance Falloff Factor

NFL = Notch Filter Loss or Waveguide Loss

Field Strength Calculation Example:

Given receiver input reading of 51.5 dB μ V; Antenna Factor of 8.5 dB; Cable Loss of 1.3 dB; Falloff Factor of 0 dB, an Amplifier Gain of 26 dB and Notch Filter Loss of 1 dB. The Field Strength of the measured emission is:

$$FS = 51.5 + 8.5 + 1.3 - 26.0 + 1 = 36.3 \text{ dB}\mu\text{V/m}$$

Conversion between dB μ V/m (or dB μ V) and μ V/m (or μ V) are done as:

$$\text{Level (dB}\mu\text{V/m)} = 20 * \text{Log (level (\mu\text{V/m}))}$$

$$40 \text{ dB}\mu\text{V/m} = 100 \mu\text{V/m}$$

$$48 \text{ dB}\mu\text{V/m} = 250 \mu\text{V/m}$$

This test report may be reproduced in full only. The document may only be updated by MiCOM Labs personnel. Any changes will be noted in the Document History section of the report.



Title: Aruba Networks APIN0214, APIN0215
To: FCC 47 CFR Part 15.407 & IC RSS-210
Serial #: ARUB179-U8 Rev B
Issue Date: 2nd September 2014
Page: 76 of 330

The following formula is used to convert the equipment isotropic radiated power (eirp) to field strength (dB μ V/m);

$$E = 1000000 \times \sqrt{30P} / 3 \mu\text{V/m}$$

where P is the EIRP in Watts

Therefore: -27 dBm/MHz = 68.23 dB μ V/m

Note: The data in this Section identifies that the EUT is in compliance with the -27dBm/MHz EIRP limit (68.23 dB μ V/m) for out of band emissions. All out of band emissions are less than 68.23 dB μ V/m.

This test report may be reproduced in full only. The document may only be updated by MiCOM Labs personnel. Any changes will be noted in the Document History section of the report.



Specification

Radiated Spurious Emissions

15.407 (b)(2). All emissions outside of the 5,150-5,350MHz band shall not exceed an EIRP of -27dBm/MHz.

FCC §15.205 (a) Except as shown in paragraph (d) of 15.205 (a), only spurious emissions are permitted in any of the frequency bands listed.

FCC §15.205 (a) Except as shown in paragraphs (d) and (e) of this section, the field strength of emissions appearing within these frequency bands shall not exceed the limits shown in Section §15.209. At frequencies equal to or less than 1000 MHz, compliance with the limits in Section 15.209 shall be demonstrated using measurement instrumentation employing a CISPR quasi-peak detector. Above 1000 MHz, compliance with the emission limits in Section 15.209 shall be demonstrated based on the average value of the measured emissions. The provisions in Section 15.35 apply to these measurements.

FCC §15.209 (a) Except as provided elsewhere in this subpart, the emissions from an intentional radiator shall not exceed the field strength levels specified in the following table.

RSS-210 §A9.3(2) For transmitters operating in the 5250-5350 MHz band, all emissions outside the 5150-5350 MHz band shall not exceed -27 dBm/MHz e.i.r.p. Devices operating in the 5250-5350 MHz band that generate emissions in the 5150-5250 MHz band shall not exceed out of band emission limit of 27 dBm/MHz e.i.r.p. in the 5150-5250 MHz band in order to operate indoor/outdoor, or alternatively shall comply with the spectral power density for operation within the 5150-5250 MHz band and shall be labeled "for indoor use only".

RSS-Gen §4.7 The search for unwanted emissions shall be from the lowest frequency internally generated or used in the device (local oscillator, intermediate of carrier frequency), or from 30 MHz, whichever is the lowest frequency, to the 5th harmonic of the highest frequency generated without exceeding 40 GHz.

RSS-Gen §6 Receiver Spurious Emission Standard

If a radiated measurement is made, all spurious emissions shall comply with the limits of the following Table. The resolution bandwidth of the spectrum analyzer shall be 100 kHz for spurious emission measurements below 1.0 GHz and 1.0 MHz for measurements above 1.0 GHz



Title: Aruba Networks APIN0214, APIN0215
To: FCC 47 CFR Part 15.407 & IC RSS-210
Serial #: ARUB179-U8 Rev B
Issue Date: 2nd September 2014
Page: 78 of 330

Table 1: FCC 15.209 Spurious Emissions Limits

Frequency (MHz)	Field Strength ($\mu\text{V/m}$)	Field Strength ($\text{dB}\mu\text{V/m}$)	Measurement Distance (meters)
30-88	100	40.0	3
88-216	150	43.5	3
216-960	200	46.0	3
Above 960	500	54.0	3

This test report may be reproduced in full only. The document may only be updated by MiCOM Labs personnel. Any changes will be noted in the Document History section of the report.



Title: Aruba Networks APIN0214, APIN0215
To: FCC 47 CFR Part 15.407 & IC RSS-210
Serial #: ARUB179-U8 Rev B
Issue Date: 2nd September 2014
Page: 79 of 330

6.1.2.1. Integral Antenna – Spurious Emissions

Test Freq.	5260 MHz	Engineer	SB
Variant	802.11a; 6 Mbs	Temp (°C)	18.5
Freq. Range	1000 MHz - 18000 MHz	Rel. Hum.(%)	34
Power Setting	20	Press. (mBars)	1004
Antenna	Integral	Duty Cycle (%)	99
Test Notes 1	AP215 P302; EUT=Vertical; S/N : CK0000953; MAC: 24 DE C6 CF 5D 38;		
Test Notes 2	POE:PowerDSine 9001GR 55VDC / 350mA;		

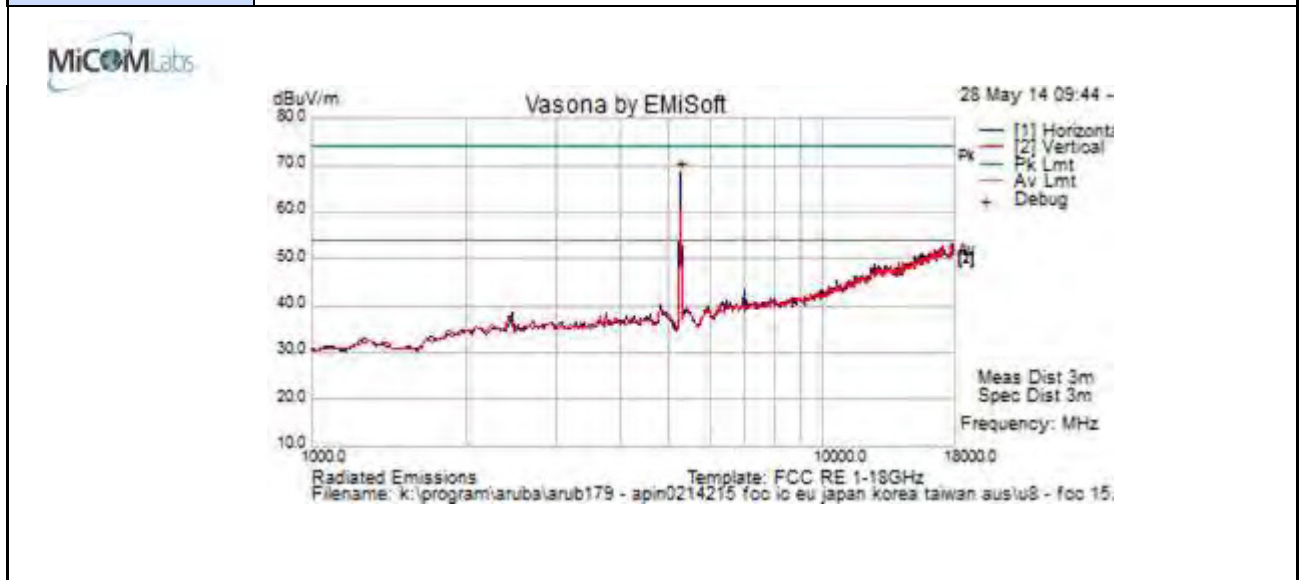

Formally measured emission peaks

Frequency MHz	Raw dBuV	Cable Loss	AF dB	Level dBuV/m	Measurement Type	Pol	Hgt cm	Azt Deg	Limit dBuV/m	Margin dB	Pass /Fail	Comments
5258.517	64.8	5.9	-2.2	68.5	Peak [Scan]	H	100					FUND
Legend: TX = Transmitter Emissions; DIG = Digital Emissions; FUND = Fundamental; WB = Wideband Emission NRB = Non-Restricted Band. Limit = 68.23 dBuV/m; RB = Restricted Band. Limits per 15.205												

This test report may be reproduced in full only. The document may only be updated by MiCOM Labs personnel. Any changes will be noted in the Document History section of the report.



Title: Aruba Networks APIN0214, APIN0215
To: FCC 47 CFR Part 15.407 & IC RSS-210
Serial #: ARUB179-U8 Rev B
Issue Date: 2nd September 2014
Page: 80 of 330

Test Freq.	5300 MHz	Engineer	SB
Variant	802.11a; 6 Mbs	Temp (°C)	18.5
Freq. Range	1000 MHz - 18000 MHz	Rel. Hum.(%)	34
Power Setting	20	Press. (mBars)	1004
Antenna	Integral	Duty Cycle (%)	99
Test Notes 1	AP215 P302; EUT=Vertical; S/N : CK0000953; MAC: 24 DE C6 CF 5D 38;		
Test Notes 2	POE:PowerDSine 9001GR 55VDC / 350mA;		

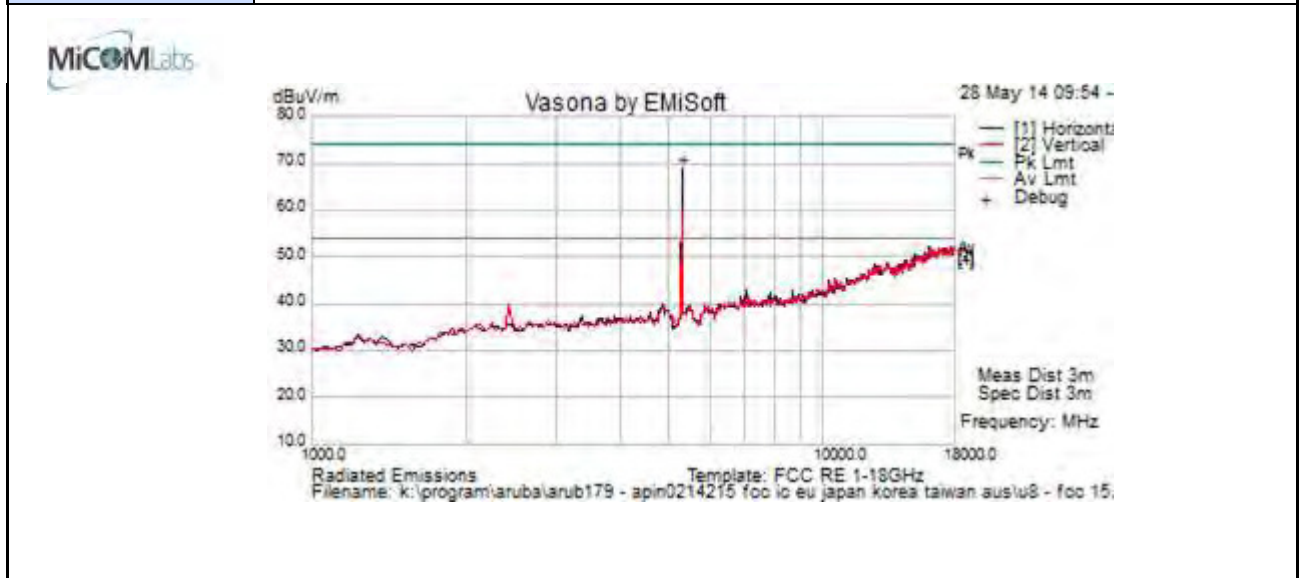

Formally measured emission peaks

Frequency MHz	Raw dBuV	Cable Loss	AF dB	Level dBuV/m	Measurement Type	Pol	Hgt cm	Azt Deg	Limit dBuV/m	Margin dB	Pass /Fail	Comments
5292.585	64.9	6.0	-2.1	68.8	Peak [Scan]	H	150					FUND
Legend: TX = Transmitter Emissions; DIG = Digital Emissions; FUND = Fundamental; WB = Wideband Emission NRB = Non-Restricted Band. Limit = 68.23 dBuV/m; RB = Restricted Band. Limits per 15.205												

This test report may be reproduced in full only. The document may only be updated by MiCOM Labs personnel. Any changes will be noted in the Document History section of the report.



Title: Aruba Networks APIN0214, APIN0215
To: FCC 47 CFR Part 15.407 & IC RSS-210
Serial #: ARUB179-U8 Rev B
Issue Date: 2nd September 2014
Page: 81 of 330

Test Freq.	5320 MHz	Engineer	SB
Variant	802.11a; 6 Mbs	Temp (°C)	18.5
Freq. Range	1000 MHz - 18000 MHz	Rel. Hum.(%)	34
Power Setting	20	Press. (mBars)	1004
Antenna	Integral	Duty Cycle (%)	99
Test Notes 1	AP215 P302; EUT=Vertical; S/N : CK0000953; MAC: 24 DE C6 CF 5D 38;		
Test Notes 2	POE:PowerDSine 9001GR 55VDC / 350mA;		

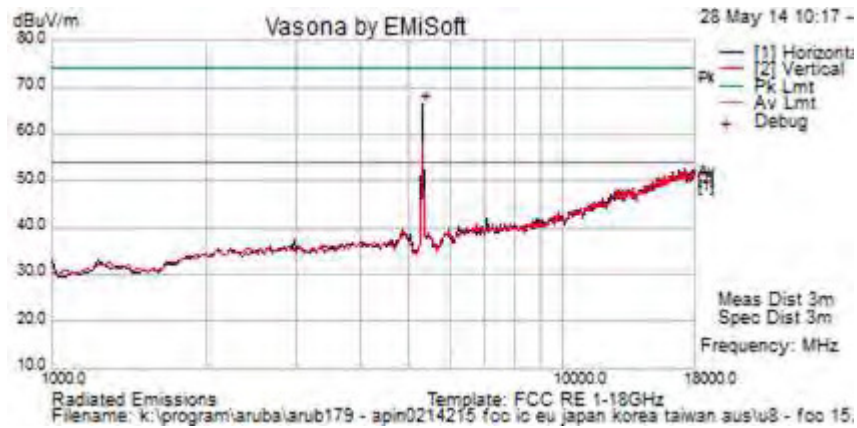

Formally measured emission peaks

Frequency MHz	Raw dBuV	Cable Loss	AF dB	Level dBuV/m	Measurement Type	Pol	Hgt cm	Azt Deg	Limit dBuV/m	Margin dB	Pass /Fail	Comments
5326.653	62.3	6.0	-1.9	66.4	Peak [Scan]	H	150					FUND
Legend: TX = Transmitter Emissions; DIG = Digital Emissions; FUND = Fundamental; WB = Wideband Emission NRB = Non-Restricted Band. Limit = 68.23 dBuV/m; RB = Restricted Band. Limits per 15.205												

This test report may be reproduced in full only. The document may only be updated by MiCOM Labs personnel. Any changes will be noted in the Document History section of the report.



Title: Aruba Networks APIN0214, APIN0215
To: FCC 47 CFR Part 15.407 & IC RSS-210
Serial #: ARUB179-U8 Rev B
Issue Date: 2nd September 2014
Page: 82 of 330

Test Freq.	5500 MHz	Engineer	SB
Variant	802.11a; 6 Mbs	Temp (°C)	18.5
Freq. Range	1000 MHz - 18000 MHz	Rel. Hum.(%)	34
Power Setting	20	Press. (mBars)	1004
Antenna	Integral	Duty Cycle (%)	99
Test Notes 1	AP215 P302; EUT=Vertical; S/N : CK0000953; MAC: 24 DE C6 CF 5D 38;		
Test Notes 2	POE:PowerDSine 9001GR 55VDC / 350mA;		

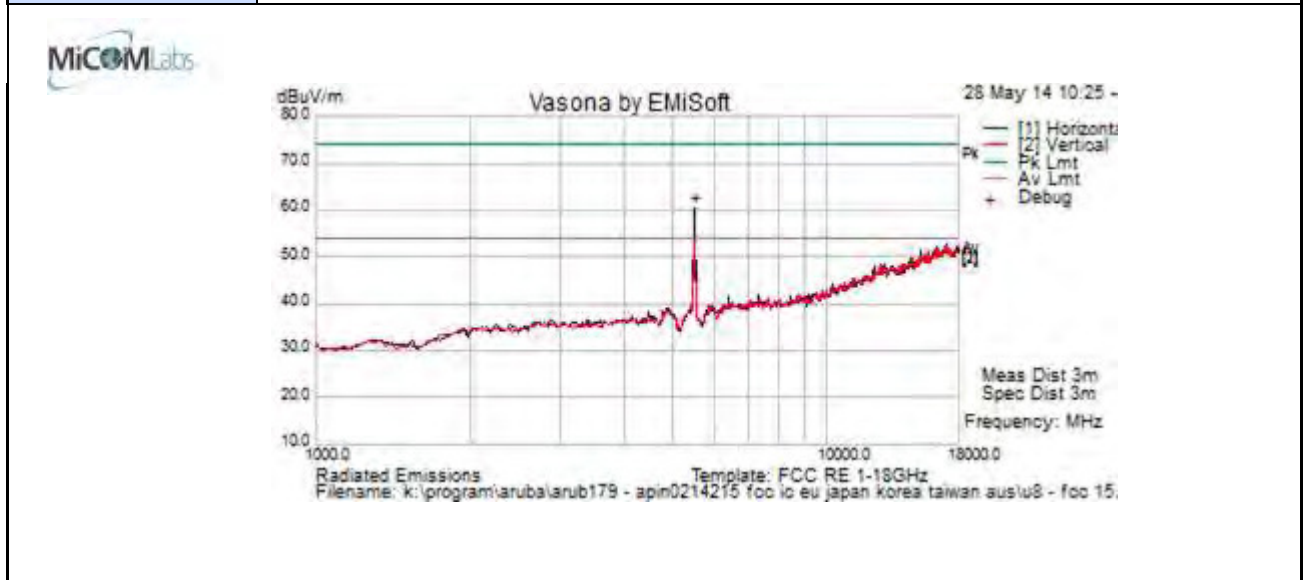

Formally measured emission peaks

Frequency MHz	Raw dBuV	Cable Loss	AF dB	Level dBuV/m	Measurement Type	Pol	Hgt cm	Azt Deg	Limit dBuV/m	Margin dB	Pass /Fail	Comments
5496.994	56.5	6.1	-2.0	60.5	Peak [Scan]	H	100					FUND
Legend: TX = Transmitter Emissions; DIG = Digital Emissions; FUND = Fundamental; WB = Wideband Emission NRB = Non-Restricted Band. Limit = 68.23 dBuV/m; RB = Restricted Band. Limits per 15.205												

This test report may be reproduced in full only. The document may only be updated by MiCOM Labs personnel. Any changes will be noted in the Document History section of the report.



Title: Aruba Networks APIN0214, APIN0215
To: FCC 47 CFR Part 15.407 & IC RSS-210
Serial #: ARUB179-U8 Rev B
Issue Date: 2nd September 2014
Page: 83 of 330

Test Freq.	5580 MHz	Engineer	SB
Variant	802.11a; 6 Mbs	Temp (°C)	18.5
Freq. Range	1000 MHz - 18000 MHz	Rel. Hum.(%)	34
Power Setting	20	Press. (mBars)	1004
Antenna	Integral	Duty Cycle (%)	99
Test Notes 1	AP215 P302; EUT=Vertical; S/N : CK0000953; MAC: 24 DE C6 CF 5D 38;		
Test Notes 2	POE:PowerDSine 9001GR 55VDC / 350mA;		

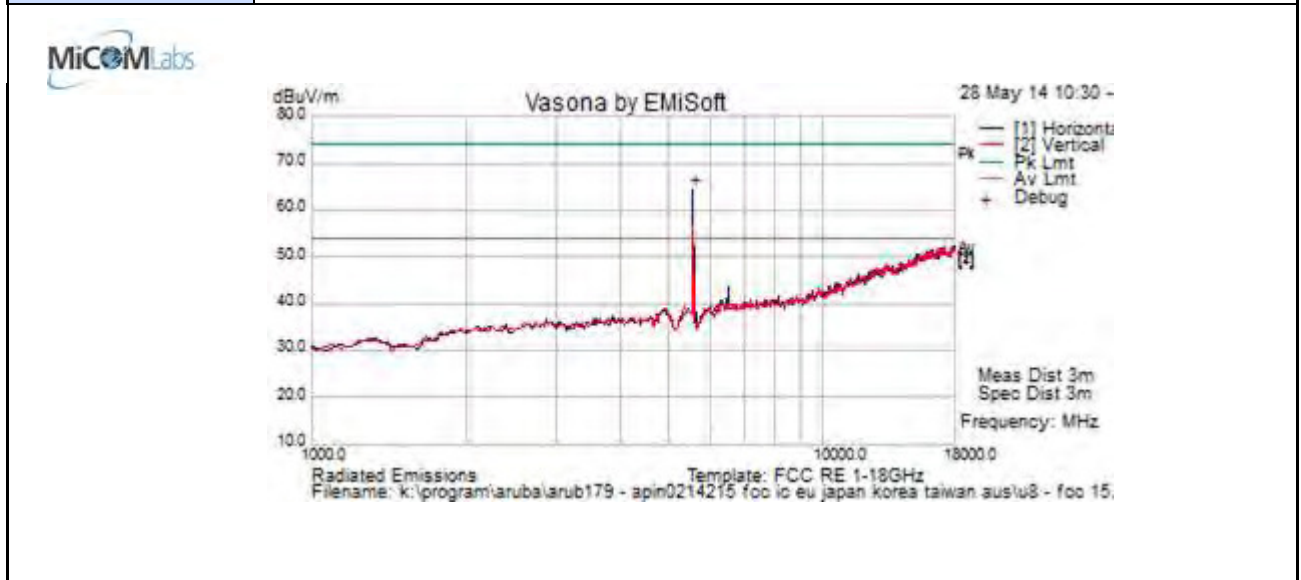

Formally measured emission peaks

Frequency MHz	Raw dBuV	Cable Loss	AF dB	Level dBuV/m	Measurement Type	Pol	Hgt cm	Azt Deg	Limit dBuV/m	Margin dB	Pass /Fail	Comments
5565.130	60.5	6.1	-2.1	64.5	Peak [Scan]	H	100					FUND
Legend: TX = Transmitter Emissions; DIG = Digital Emissions; FUND = Fundamental; WB = Wideband Emission NRB = Non-Restricted Band. Limit = 68.23 dBuV/m; RB = Restricted Band. Limits per 15.205												

This test report may be reproduced in full only. The document may only be updated by MiCOM Labs personnel. Any changes will be noted in the Document History section of the report.



Title: Aruba Networks APIN0214, APIN0215
To: FCC 47 CFR Part 15.407 & IC RSS-210
Serial #: ARUB179-U8 Rev B
Issue Date: 2nd September 2014
Page: 84 of 330

Test Freq.	5700 MHz	Engineer	SB
Variant	802.11a; 6 Mbs	Temp (°C)	18.5
Freq. Range	1000 MHz - 18000 MHz	Rel. Hum.(%)	34
Power Setting	20	Press. (mBars)	1004
Antenna	Integral	Duty Cycle (%)	99
Test Notes 1	AP215 P302; EUT=Vertical; S/N : CK0000953; MAC: 24 DE C6 CF 5D 38;		
Test Notes 2	POE:PowerDSine 9001GR 55VDC / 350mA;		

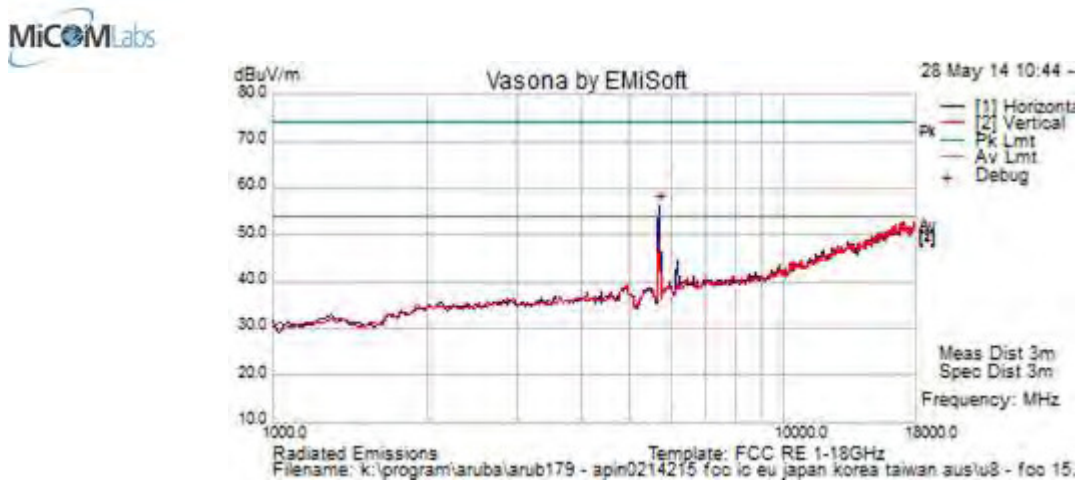

Formally measured emission peaks

Frequency MHz	Raw dBuV	Cable Loss	AF dB	Level dBuV/m	Measurement Type	Pol	Hgt cm	Azt Deg	Limit dBuV/m	Margin dB	Pass /Fail	Comments
5701.403	52.1	6.2	-2.0	56.3	Peak [Scan]	H	100					FUND
Legend: TX = Transmitter Emissions; DIG = Digital Emissions; FUND = Fundamental; WB = Wideband Emission NRB = Non-Restricted Band. Limit = 68.23 dBuV/m; RB = Restricted Band. Limits per 15.205												

This test report may be reproduced in full only. The document may only be updated by MiCOM Labs personnel. Any changes will be noted in the Document History section of the report.



Integral Antenna - Radiated Band-Edge

Peak Limit 74.0 dBµV, Average Limit 54.0 dBµV

		5350 MHz		
		dBµV		Power Setting
Operational Mode	Operating Frequency (MHz)	Peak	Average	
a	5320.0	64.74	53.49	17.0
n HT-20	5320.0	64.72	53.93	17.0
n HT-40	5310.0	66.25	53.85	15.75
ac-80	5290.0	69.85	53.49	13.0

		5470 MHz		
		dBµV		Power Setting
Operational Mode	Operating Frequency	Peak	Average	
a	5500.0	62.37	50.68	20.0
n HT-20	5500.0	62.66	46.50	20.0
n HT-40	5510.0	68.13	50.81	20.0
ac-80	5530.0	70.09	53.02	16.5

This test report may be reproduced in full only. The document may only be updated by MiCOM Labs personnel. Any changes will be noted in the Document History section of the report.



Title: Aruba Networks APIN0214, APIN0215
To: FCC 47 CFR Part 15.407 & IC RSS-210
Serial #: ARUB179-U8 Rev B
Issue Date: 2nd September 2014
Page: 86 of 330

6.1.2.2. AP-ANT-1B – Spurious Emissions

Test Freq.	5260 MHz	Engineer	SB
Variant	802.11a; 6 Mbs	Temp (°C)	18.5
Freq. Range	1000 MHz - 18000 MHz	Rel. Hum.(%)	34
Power Setting	20	Press. (mBars)	1004
Antenna	AP ANT 1B	Duty Cycle (%)	99
Test Notes 1	AP214 P302; EUT=Vertical; S/N : CK0000634; MAC: 24 DE C6 CF 5A BA;		
Test Notes 2	POE:PowerDSine 9001GR 55VDC / 350mA;		

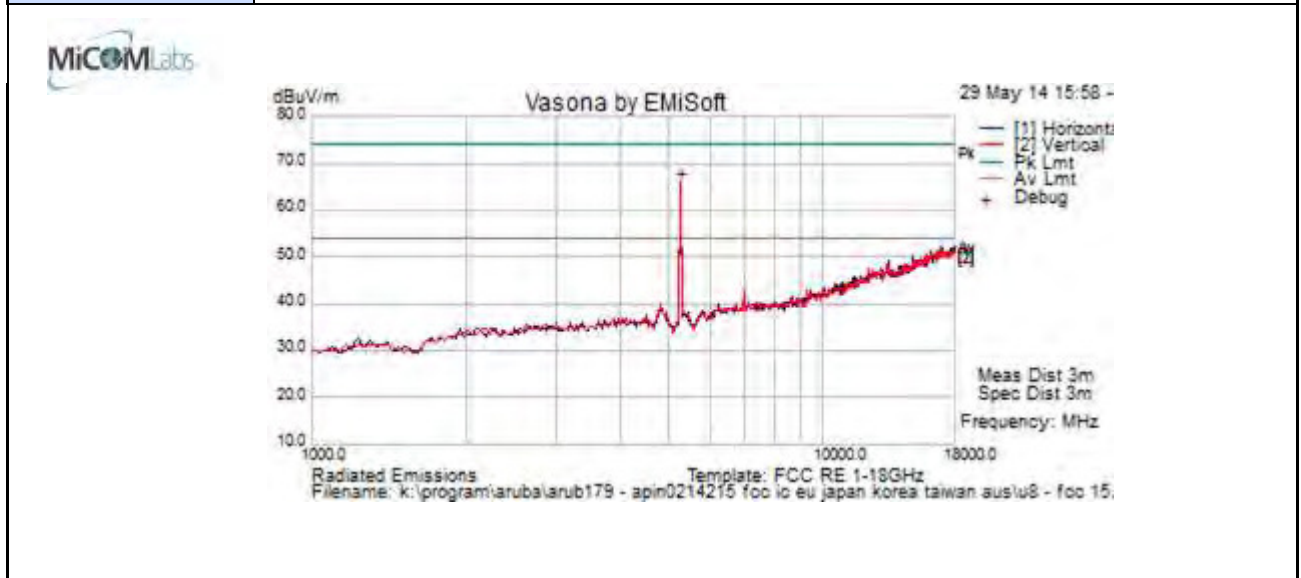

Formally measured emission peaks

Frequency MHz	Raw dBuV	Cable Loss	AF dB	Level dBuV/m	Measurement Type	Pol	Hgt cm	Azt Deg	Limit dBuV/m	Margin dB	Pass /Fail	Comments
5258.517	62.1	5.9	-2.2	65.8	Peak [Scan]	V	100					FUND

Legend:	TX = Transmitter Emissions; DIG = Digital Emissions; FUND = Fundamental; WB = Wideband Emission
	NRB = Non-Restricted Band. Limit = 68.23 dBuV/m; RB = Restricted Band. Limits per 15.205

This test report may be reproduced in full only. The document may only be updated by MiCOM Labs personnel. Any changes will be noted in the Document History section of the report.



Title: Aruba Networks APIN0214, APIN0215
To: FCC 47 CFR Part 15.407 & IC RSS-210
Serial #: ARUB179-U8 Rev B
Issue Date: 2nd September 2014
Page: 87 of 330

Test Freq.	5300 MHz	Engineer	SB
Variant	802.11a; 6 Mbs	Temp (°C)	18.5
Freq. Range	1000 MHz - 18000 MHz	Rel. Hum.(%)	34
Power Setting	20	Press. (mBars)	1004
Antenna	AP ANT 1B	Duty Cycle (%)	99
Test Notes 1	AP214 P302; EUT=Vertical; S/N : CK0000634; MAC: 24 DE C6 CF 5A BA;		
Test Notes 2	POE:PowerDSine 9001GR 55VDC / 350mA;		

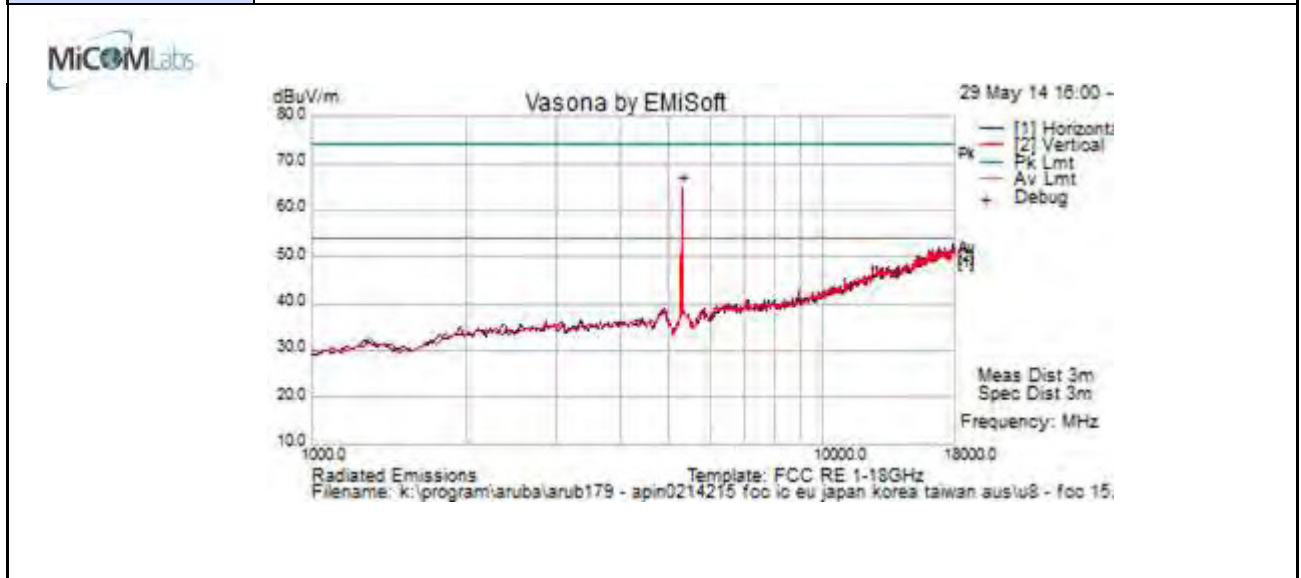

Formally measured emission peaks

Frequency MHz	Raw dBuV	Cable Loss	AF dB	Level dBuV/m	Measurement Type	Pol	Hgt cm	Azt Deg	Limit dBuV/m	Margin dB	Pass /Fail	Comments
5292.585	61.0	6.0	-2.1	64.8	Peak [Scan]	V	100					FUND
Legend: TX = Transmitter Emissions; DIG = Digital Emissions; FUND = Fundamental; WB = Wideband Emission NRB = Non-Restricted Band. Limit = 68.23 dBuV/m; RB = Restricted Band. Limits per 15.205												

This test report may be reproduced in full only. The document may only be updated by MiCOM Labs personnel. Any changes will be noted in the Document History section of the report.



Title: Aruba Networks APIN0214, APIN0215
To: FCC 47 CFR Part 15.407 & IC RSS-210
Serial #: ARUB179-U8 Rev B
Issue Date: 2nd September 2014
Page: 88 of 330

Test Freq.	5320 MHz	Engineer	SB
Variant	802.11a; 6 Mbs	Temp (°C)	18.5
Freq. Range	1000 MHz - 18000 MHz	Rel. Hum.(%)	34
Power Setting	20	Press. (mBars)	1004
Antenna	AP ANT 1B	Duty Cycle (%)	99
Test Notes 1	AP214 P302; EUT=Vertical; S/N : CK0000634; MAC: 24 DE C6 CF 5A BA;		
Test Notes 2	POE:PowerDSine 9001GR 55VDC / 350mA;		

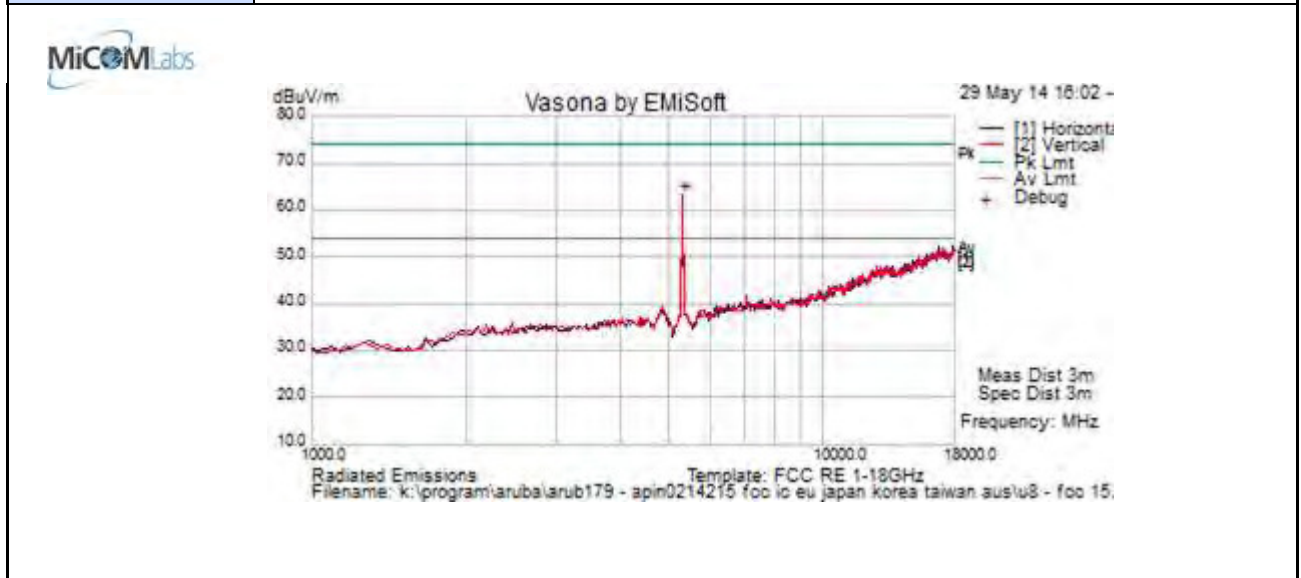

Formally measured emission peaks

Frequency MHz	Raw dBuV	Cable Loss	AF dB	Level dBuV/m	Measurement Type	Pol	Hgt cm	Azt Deg	Limit dBuV/m	Margin dB	Pass /Fail	Comments
5326.653	59.3	6.0	-1.9	63.4	Peak [Scan]	V	100					FUND
Legend: TX = Transmitter Emissions; DIG = Digital Emissions; FUND = Fundamental; WB = Wideband Emission NRB = Non-Restricted Band. Limit = 68.23 dBuV/m; RB = Restricted Band. Limits per 15.205												

This test report may be reproduced in full only. The document may only be updated by MiCOM Labs personnel. Any changes will be noted in the Document History section of the report.



Title: Aruba Networks APIN0214, APIN0215
To: FCC 47 CFR Part 15.407 & IC RSS-210
Serial #: ARUB179-U8 Rev B
Issue Date: 2nd September 2014
Page: 89 of 330

Test Freq.	5500 MHz	Engineer	SB
Variant	802.11a; 6 Mbs	Temp (°C)	18.5
Freq. Range	1000 MHz - 18000 MHz	Rel. Hum.(%)	34
Power Setting	20	Press. (mBars)	1004
Antenna	AP ANT 1B	Duty Cycle (%)	99
Test Notes 1	AP214 P302; EUT=Vertical; S/N : CK0000634; MAC: 24 DE C6 CF 5A BA;		
Test Notes 2	POE:PowerDSine 9001GR 55VDC / 350mA;		

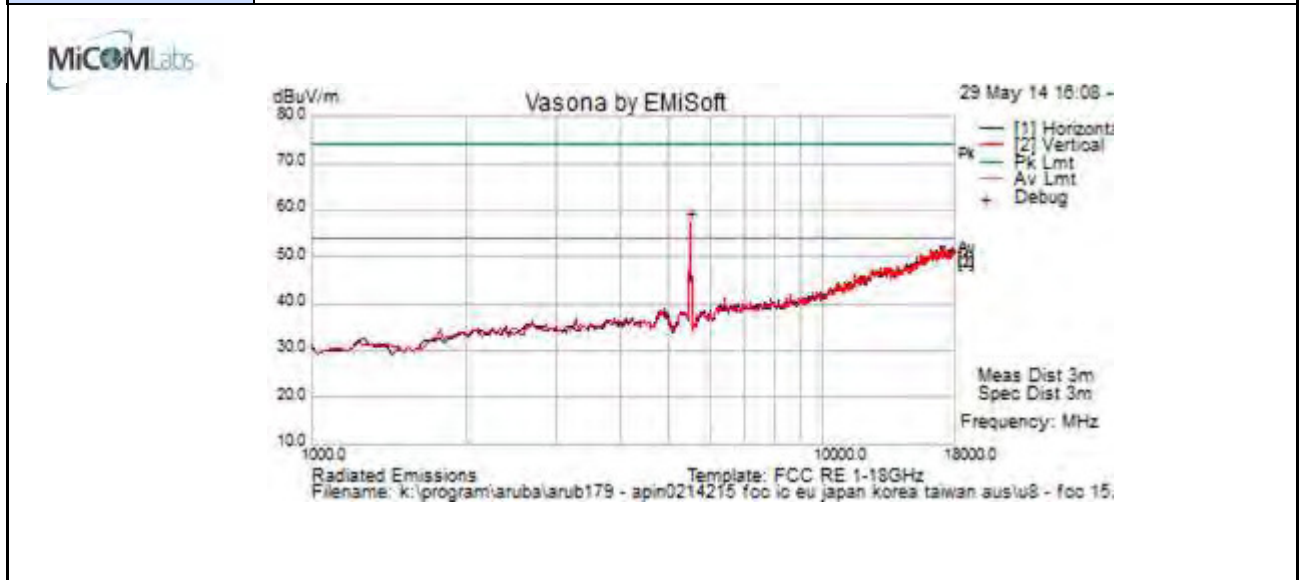

Formally measured emission peaks

Frequency MHz	Raw dBuV	Cable Loss	AF dB	Level dBuV/m	Measurement Type	Pol	Hgt cm	Azt Deg	Limit dBuV/m	Margin dB	Pass /Fail	Comments
5496.994	53.3	6.1	-2.0	57.4	Peak [Scan]	V	100					FUND
Legend: TX = Transmitter Emissions; DIG = Digital Emissions; FUND = Fundamental; WB = Wideband Emission NRB = Non-Restricted Band. Limit = 68.23 dBuV/m; RB = Restricted Band. Limits per 15.205												

This test report may be reproduced in full only. The document may only be updated by MiCOM Labs personnel. Any changes will be noted in the Document History section of the report.



Title: Aruba Networks APIN0214, APIN0215
To: FCC 47 CFR Part 15.407 & IC RSS-210
Serial #: ARUB179-U8 Rev B
Issue Date: 2nd September 2014
Page: 90 of 330

Test Freq.	5580 MHz	Engineer	SB
Variant	802.11a; 6 Mbs	Temp (°C)	18.5
Freq. Range	1000 MHz - 18000 MHz	Rel. Hum.(%)	34
Power Setting	20	Press. (mBars)	1004
Antenna	AP ANT 1B	Duty Cycle (%)	99
Test Notes 1	AP214 P302; EUT=Vertical; S/N : CK0000634; MAC: 24 DE C6 CF 5A BA;		
Test Notes 2	POE:PowerDSine 9001GR 55VDC / 350mA;		

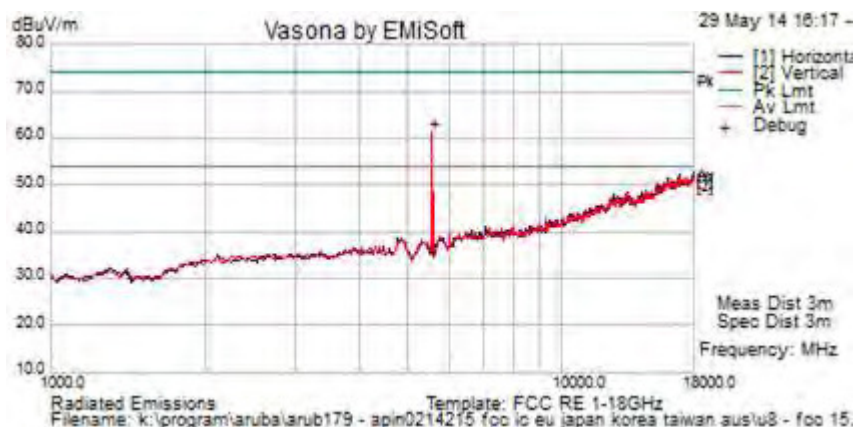

Formally measured emission peaks

Frequency MHz	Raw dBuV	Cable Loss	AF dB	Level dBuV/m	Measurement Type	Pol	Hgt cm	Azt Deg	Limit dBuV/m	Margin dB	Pass /Fail	Comments
5565.130	60.5	6.1	-2.1	64.5	Peak [Scan]	H	100					FUND
Legend: TX = Transmitter Emissions; DIG = Digital Emissions; FUND = Fundamental; WB = Wideband Emission NRB = Non-Restricted Band. Limit = 68.23 dBuV/m; RB = Restricted Band. Limits per 15.205												

This test report may be reproduced in full only. The document may only be updated by MiCOM Labs personnel. Any changes will be noted in the Document History section of the report.



Title: Aruba Networks APIN0214, APIN0215
To: FCC 47 CFR Part 15.407 & IC RSS-210
Serial #: ARUB179-U8 Rev B
Issue Date: 2nd September 2014
Page: 91 of 330

Test Freq.	5700 MHz	Engineer	SB
Variant	802.11a; 6 Mbs	Temp (°C)	18.5
Freq. Range	1000 MHz - 18000 MHz	Rel. Hum.(%)	34
Power Setting	20	Press. (mBars)	1004
Antenna	AP ANT 1B	Duty Cycle (%)	99
Test Notes 1	AP214 P302; EUT=Vertical; S/N : CK0000634; MAC: 24 DE C6 CF 5A BA;		
Test Notes 2	POE:PowerDSine 9001GR 55VDC / 350mA;		

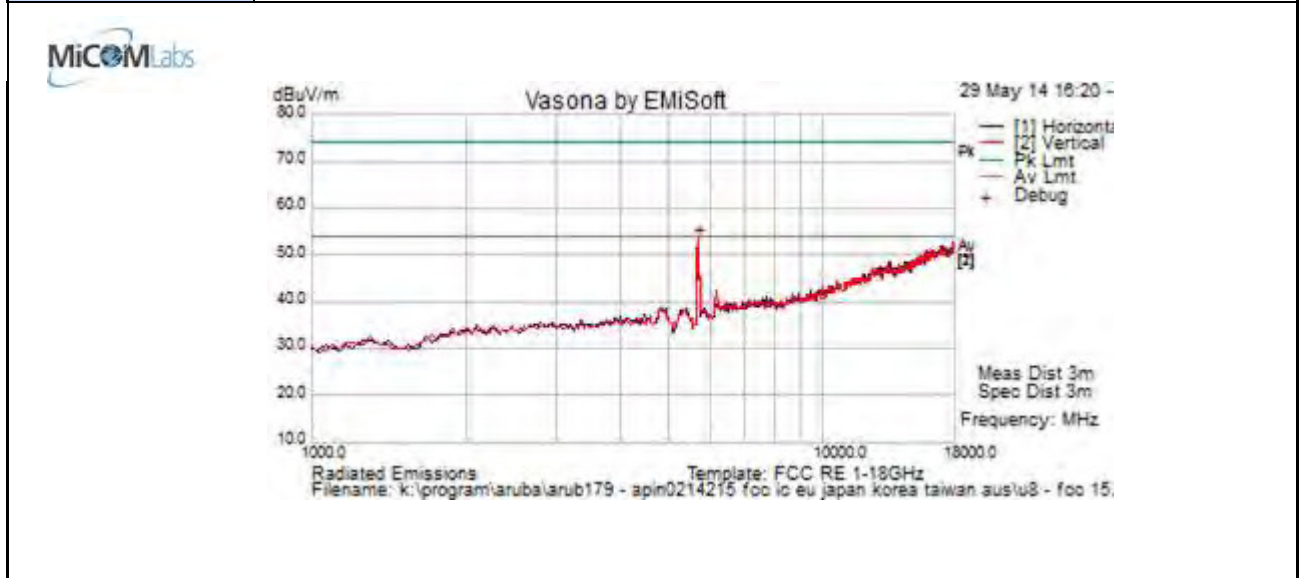

Formally measured emission peaks

Frequency MHz	Raw dBuV	Cable Loss	AF dB	Level dBuV/m	Measurement Type	Pol	Hgt cm	Azt Deg	Limit dBuV/m	Margin dB	Pass /Fail	Comments
5701.403	52.1	6.2	-2.0	56.3	Peak [Scan]	H	100					FUND
Legend: TX = Transmitter Emissions; DIG = Digital Emissions; FUND = Fundamental; WB = Wideband Emission NRB = Non-Restricted Band. Limit = 68.23 dBuV/m; RB = Restricted Band. Limits per 15.205												

This test report may be reproduced in full only. The document may only be updated by MiCOM Labs personnel. Any changes will be noted in the Document History section of the report.



Antenna AP-ANT-1B - Radiated Band-Edge

Peak Limit 74.0 dBµV/m, Average Limit 54.0 dBµV/m

		5350 MHz		
		dBµV		Power Setting
Operational Mode	Operating Frequency (MHz)	Peak	Average	
a	5320.0	62.91	48.42	20.0
n HT-20	5320.0	62.30	48.25	20.0
n HT-40	5310.0	67.86	51.89	20.0
ac-80	5290.0	71.52	53.40	17.25

		5470 MHz		
		dBµV		Power Setting
Operational Mode	Operating Frequency	Peak	Average	
a	5500.0	60.84	48.35	20.0
n HT-20	5500.0	60.56	48.52	20.0
n HT-40	5510.0	66.35	49.74	20.0
ac-80	5530.0	68.90	53.40	16.0

This test report may be reproduced in full only. The document may only be updated by MiCOM Labs personnel. Any changes will be noted in the Document History section of the report.



Title: Aruba Networks APIN0214, APIN0215
To: FCC 47 CFR Part 15.407 & IC RSS-210
Serial #: ARUB179-U8 Rev B
Issue Date: 2nd September 2014
Page: 93 of 330

6.1.2.3. AP-ANT-13B – Spurious Emissions

Test Freq.	5260 MHz	Engineer	SB
Variants	802.11a; 6 Mbs	Temp (°C)	18.5
Freq. Range	1000 MHz - 18000 MHz	Rel. Hum.(%)	34
Power Setting	20	Press. (mBars)	1004
Antenna	AP ANT 13B	Duty Cycle (%)	99
Test Notes 1	AP214 P302; EUT=Vertical; S/N : CK0000634; MAC: 24 DE C6 CF 5A BA;		
Test Notes 2	POE:PowerDSine 9001GR 55VDC / 350mA;		

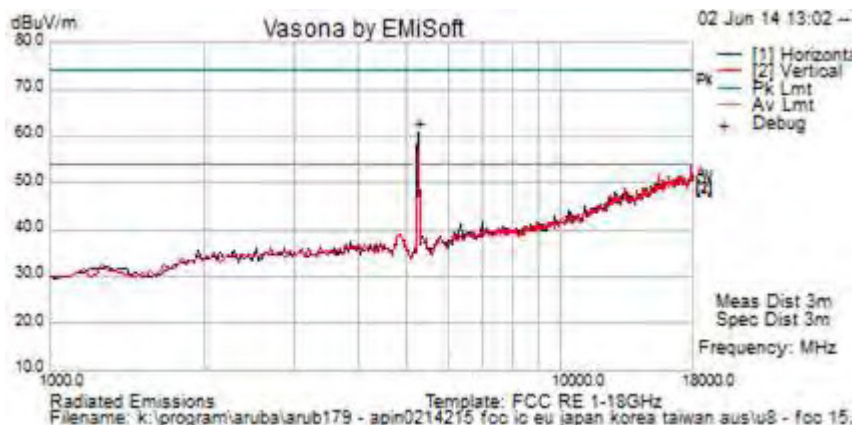

Formally measured emission peaks

Frequency MHz	Raw dBuV	Cable Loss	AF dB	Level dBuV/m	Measurement Type	PoI	Hgt cm	Azt Deg	Limit dBuV/m	Margin dB	Pass /Fail	Comments
5258.517	67.0	5.9	-2.2	70.7	Peak [Scan]	V	100					FUND

Legend: TX = Transmitter Emissions; DIG = Digital Emissions; FUND = Fundamental; WB = Wideband Emission
 NRB = Non-Restricted Band. Limit = 68.23 dBuV/m; RB = Restricted Band. Limits per 15.205

This test report may be reproduced in full only. The document may only be updated by MiCOM Labs personnel. Any changes will be noted in the Document History section of the report.



Title: Aruba Networks APIN0214, APIN0215
To: FCC 47 CFR Part 15.407 & IC RSS-210
Serial #: ARUB179-U8 Rev B
Issue Date: 2nd September 2014
Page: 94 of 330

Test Freq.	5300 MHz	Engineer	SB
Variant	802.11a; 6 Mbs	Temp (°C)	18.5
Freq. Range	1000 MHz - 18000 MHz	Rel. Hum.(%)	34
Power Setting	20	Press. (mBars)	1004
Antenna	AP ANT 13B	Duty Cycle (%)	99
Test Notes 1	AP214 P302; EUT=Vertical; S/N : CK0000634; MAC: 24 DE C6 CF 5A BA;		
Test Notes 2	POE:PowerDSine 9001GR 55VDC / 350mA;		

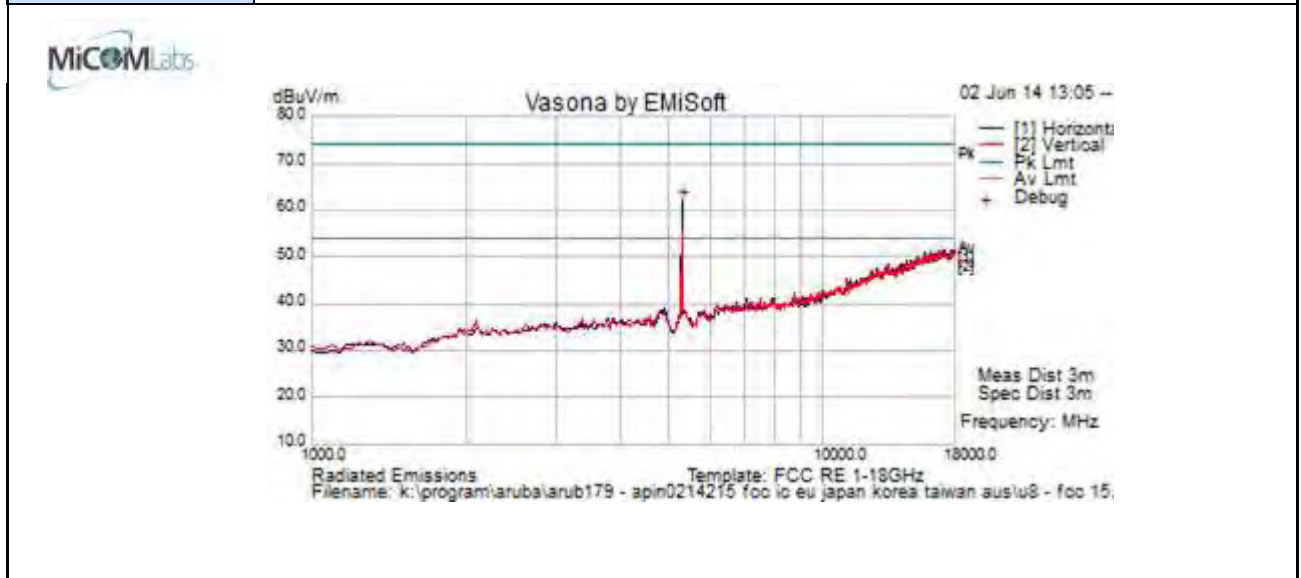

Formally measured emission peaks

Frequency MHz	Raw dBuV	Cable Loss	AF dB	Level dBuV/m	Measurement Type	Pol	Hgt cm	Azt Deg	Limit dBuV/m	Margin dB	Pass /Fail	Comments
5292.585	63.2	6.0	-2.1	67.1	Peak [Scan]	V	100					FUND
Legend: TX = Transmitter Emissions; DIG = Digital Emissions; FUND = Fundamental; WB = Wideband Emission NRB = Non-Restricted Band. Limit = 68.23 dBuV/m; RB = Restricted Band. Limits per 15.205												

This test report may be reproduced in full only. The document may only be updated by MiCOM Labs personnel. Any changes will be noted in the Document History section of the report.



Title: Aruba Networks APIN0214, APIN0215
To: FCC 47 CFR Part 15.407 & IC RSS-210
Serial #: ARUB179-U8 Rev B
Issue Date: 2nd September 2014
Page: 95 of 330

Test Freq.	5320 MHz	Engineer	SB
Variant	802.11a; 6 Mbs	Temp (°C)	18.5
Freq. Range	1000 MHz - 18000 MHz	Rel. Hum.(%)	34
Power Setting	20	Press. (mBars)	1004
Antenna	AP ANT 13B	Duty Cycle (%)	99
Test Notes 1	AP214 P302; EUT=Vertical; S/N : CK0000634; MAC: 24 DE C6 CF 5A BA;		
Test Notes 2	POE:PowerDSine 9001GR 55VDC / 350mA;		

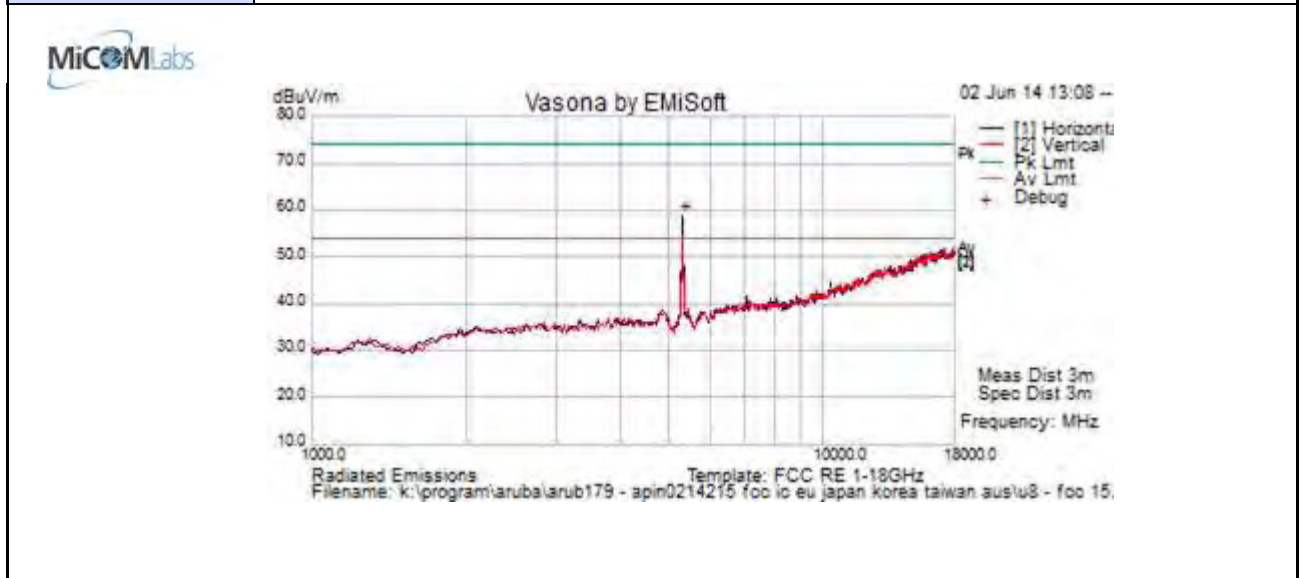

Formally measured emission peaks

Frequency MHz	Raw dBuV	Cable Loss	AF dB	Level dBuV/m	Measurement Type	Pol	Hgt cm	Azt Deg	Limit dBuV/m	Margin dB	Pass /Fail	Comments
5326.653	63.2	6.0	-1.9	67.2	Peak [Scan]	V	100					FUND
Legend: TX = Transmitter Emissions; DIG = Digital Emissions; FUND = Fundamental; WB = Wideband Emission NRB = Non-Restricted Band. Limit = 68.23 dBuV/m; RB = Restricted Band. Limits per 15.205												

This test report may be reproduced in full only. The document may only be updated by MiCOM Labs personnel. Any changes will be noted in the Document History section of the report.



Title: Aruba Networks APIN0214, APIN0215
To: FCC 47 CFR Part 15.407 & IC RSS-210
Serial #: ARUB179-U8 Rev B
Issue Date: 2nd September 2014
Page: 96 of 330

Test Freq.	5500 MHz	Engineer	SB
Variant	802.11a; 6 Mbs	Temp (°C)	18.5
Freq. Range	1000 MHz - 18000 MHz	Rel. Hum.(%)	34
Power Setting	20	Press. (mBars)	1004
Antenna	AP ANT 13B	Duty Cycle (%)	99
Test Notes 1	AP214 P302; EUT=Vertical; S/N : CK0000634; MAC: 24 DE C6 CF 5A BA;		
Test Notes 2	POE:PowerDSine 9001GR 55VDC / 350mA;		

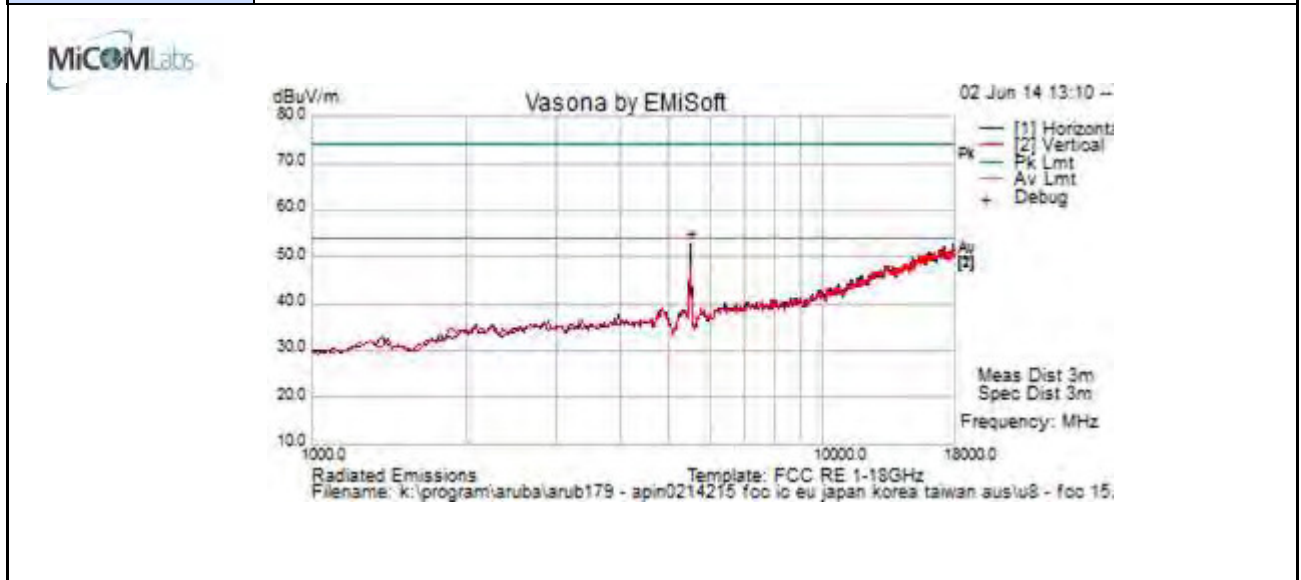

Formally measured emission peaks

Frequency MHz	Raw dBuV	Cable Loss	AF dB	Level dBuV/m	Measurement Type	Pol	Hgt cm	Azt Deg	Limit dBuV/m	Margin dB	Pass /Fail	Comments
5496.994	48.8	6.1	-2.0	52.8	Peak [Scan]	H	100					FUND
Legend: TX = Transmitter Emissions; DIG = Digital Emissions; FUND = Fundamental; WB = Wideband Emission NRB = Non-Restricted Band. Limit = 68.23 dBuV/m; RB = Restricted Band. Limits per 15.205												

This test report may be reproduced in full only. The document may only be updated by MiCOM Labs personnel. Any changes will be noted in the Document History section of the report.



Title: Aruba Networks APIN0214, APIN0215
To: FCC 47 CFR Part 15.407 & IC RSS-210
Serial #: ARUB179-U8 Rev B
Issue Date: 2nd September 2014
Page: 97 of 330

Test Freq.	5580 MHz	Engineer	SB
Variant	802.11a; 6 Mbs	Temp (°C)	18.5
Freq. Range	1000 MHz - 18000 MHz	Rel. Hum.(%)	34
Power Setting	20	Press. (mBars)	1004
Antenna	AP ANT 13B	Duty Cycle (%)	99
Test Notes 1	AP214 P302; EUT=Vertical; S/N : CK0000634; MAC: 24 DE C6 CF 5A BA;		
Test Notes 2	POE:PowerDSine 9001GR 55VDC / 350mA;		

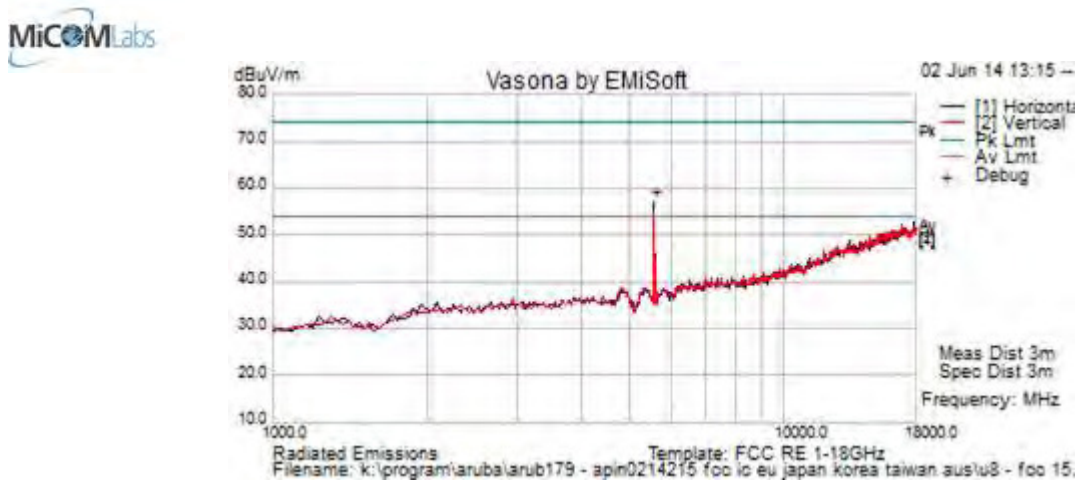

Formally measured emission peaks

Frequency MHz	Raw dBuV	Cable Loss	AF dB	Level dBuV/m	Measurement Type	Pol	Hgt cm	Azt Deg	Limit dBuV/m	Margin dB	Pass /Fail	Comments
5565.130	59.7	6.1	-2.1	63.7	Peak [Scan]	V	100					FUND
Legend: TX = Transmitter Emissions; DIG = Digital Emissions; FUND = Fundamental; WB = Wideband Emission NRB = Non-Restricted Band. Limit = 68.23 dBuV/m; RB = Restricted Band. Limits per 15.205												

This test report may be reproduced in full only. The document may only be updated by MiCOM Labs personnel. Any changes will be noted in the Document History section of the report.



Title: Aruba Networks APIN0214, APIN0215
To: FCC 47 CFR Part 15.407 & IC RSS-210
Serial #: ARUB179-U8 Rev B
Issue Date: 2nd September 2014
Page: 98 of 330

Test Freq.	5700 MHz	Engineer	SB
Variant	802.11a; 6 Mbs	Temp (°C)	18.5
Freq. Range	1000 MHz - 18000 MHz	Rel. Hum.(%)	34
Power Setting	20	Press. (mBars)	1004
Antenna	AP ANT 13B	Duty Cycle (%)	99
Test Notes 1	AP214 P302; EUT=Vertical; S/N : CK0000634; MAC: 24 DE C6 CF 5A BA;		
Test Notes 2	POE:PowerDSine 9001GR 55VDC / 350mA;		

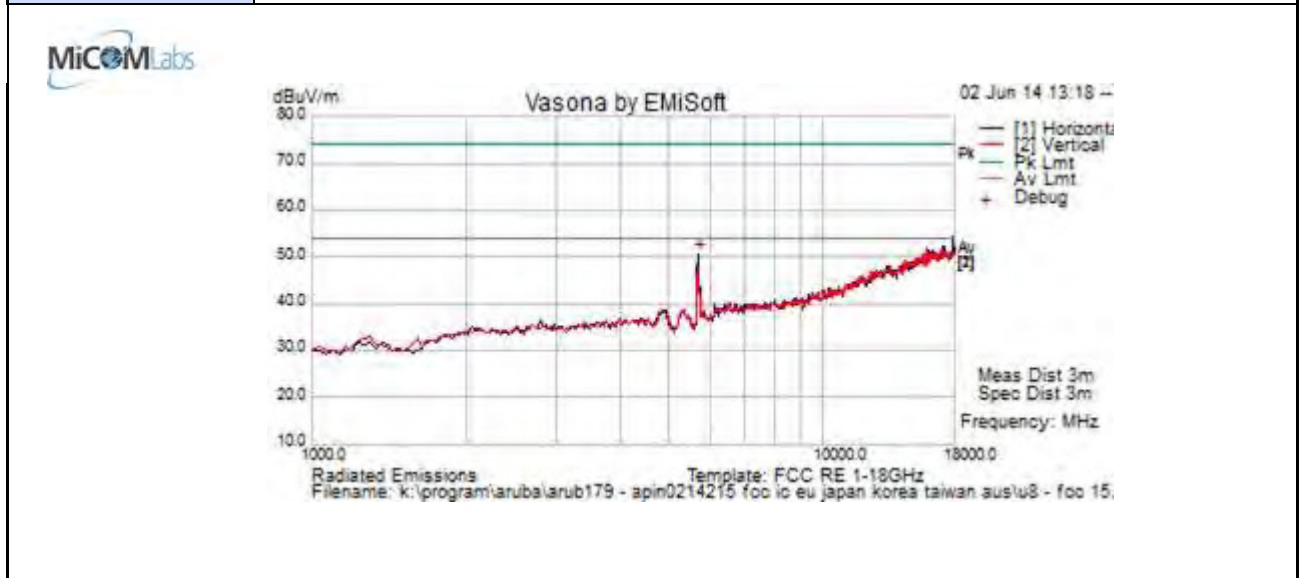

Formally measured emission peaks

Frequency MHz	Raw dBuV	Cable Loss	AF dB	Level dBuV/m	Measurement Type	Pol	Hgt cm	Azt Deg	Limit dBuV/m	Margin dB	Pass /Fail	Comments
5701.403	52.1	6.2	-2.0	56.3	Peak [Scan]	V	100					FUND
Legend: TX = Transmitter Emissions; DIG = Digital Emissions; FUND = Fundamental; WB = Wideband Emission NRB = Non-Restricted Band. Limit = 68.23 dBuV/m; RB = Restricted Band. Limits per 15.205												

This test report may be reproduced in full only. The document may only be updated by MiCOM Labs personnel. Any changes will be noted in the Document History section of the report.



Antenna AP-ANT-13B - Radiated Band-Edge

Peak Limit 74.0 dBµV/m, Average Limit 54.0 dBµV/m

		5350 MHz		
		dBµV		Power Setting
Operational Mode	Operating Frequency (MHz)	Peak	Average	
a	5320.0	62.54	49.63	20.0
n HT-20	5320.0	62.08	49.49	20.0
n HT-40	5310.0	62.49	49.54	20.0
ac-80	5290.0	72.11	53.12	16.5

		5470 MHz		
		dBµV		Power Setting
Operational Mode	Operating Frequency	Peak	Average	
a	5500.0	60.64	49.30	20.0
n HT-20	5500.0	62.90	49.20	20.0
n HT-40	5510.0	68.28	51.10	20.0
ac-80	5530.0	69.02	53.47	15.0

This test report may be reproduced in full only. The document may only be updated by MiCOM Labs personnel. Any changes will be noted in the Document History section of the report.



Title: Aruba Networks APIN0214, APIN0215
To: FCC 47 CFR Part 15.407 & IC RSS-210
Serial #: ARUB179-U8 Rev B
Issue Date: 2nd September 2014
Page: 100 of 330

6.1.2.4. AP-ANT-16 – Spurious Emissions

Test Freq.	5260 MHz	Engineer	SB
Variant	802.11a; 6 Mbs	Temp (°C)	18.5
Freq. Range	1000 MHz - 18000 MHz	Rel. Hum.(%)	34
Power Setting	20	Press. (mBars)	1004
Antenna	AP ANT 16	Duty Cycle (%)	99
Test Notes 1	AP214 P302; EUT=Vertical; S/N : CK0000634; MAC: 24 DE C6 CF 5A BA;		
Test Notes 2	POE:PowerDSine 9001GR 55VDC / 350mA;		

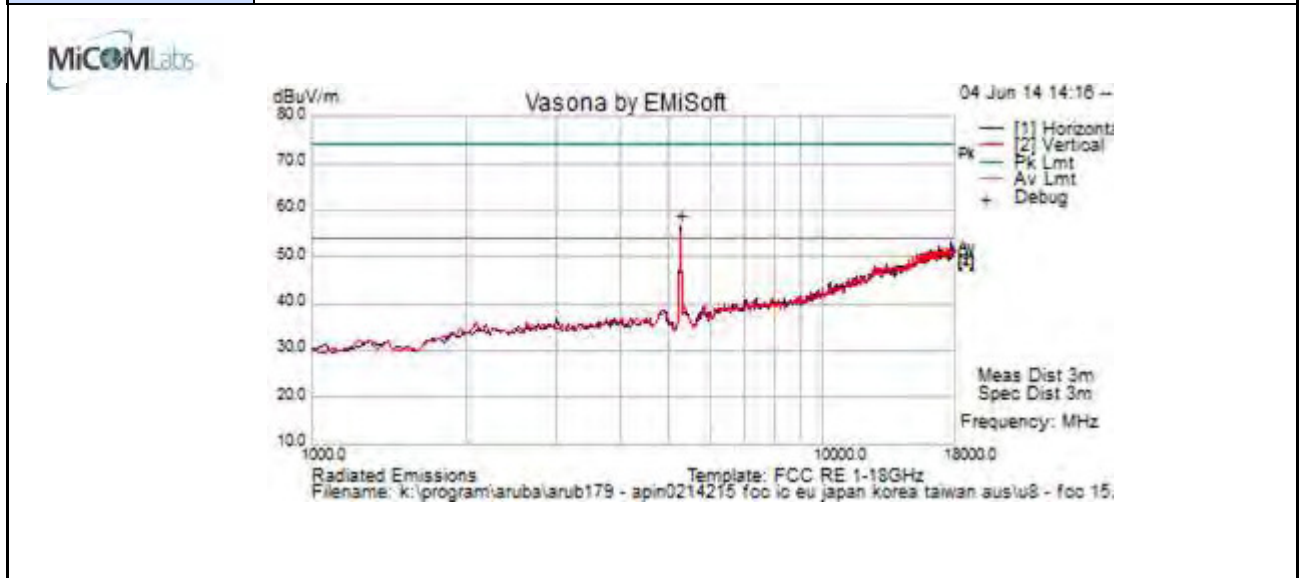

Formally measured emission peaks

Frequency MHz	Raw dBuV	Cable Loss	AF dB	Level dBuV/m	Measurement Type	Pol	Hgt cm	Azt Deg	Limit dBuV/m	Margin dB	Pass /Fail	Comments
5258.517	53.0	5.9	-2.2	56.7	Peak [Scan]	H	100					FUND
Legend: TX = Transmitter Emissions; DIG = Digital Emissions; FUND = Fundamental; WB = Wideband Emission NRB = Non-Restricted Band. Limit = 68.23 dBuV/m; RB = Restricted Band. Limits per 15.205												

This test report may be reproduced in full only. The document may only be updated by MiCOM Labs personnel. Any changes will be noted in the Document History section of the report.



Title: Aruba Networks APIN0214, APIN0215
To: FCC 47 CFR Part 15.407 & IC RSS-210
Serial #: ARUB179-U8 Rev B
Issue Date: 2nd September 2014
Page: 101 of 330

Test Freq.	5300 MHz	Engineer	SB
Variant	802.11a; 6 Mbs	Temp (°C)	18.5
Freq. Range	1000 MHz - 18000 MHz	Rel. Hum.(%)	34
Power Setting	20	Press. (mBars)	1004
Antenna	AP ANT 16	Duty Cycle (%)	99
Test Notes 1	AP214 P302; EUT=Vertical; S/N : CK0000634; MAC: 24 DE C6 CF 5A BA;		
Test Notes 2	POE:PowerDSine 9001GR 55VDC / 350mA;		

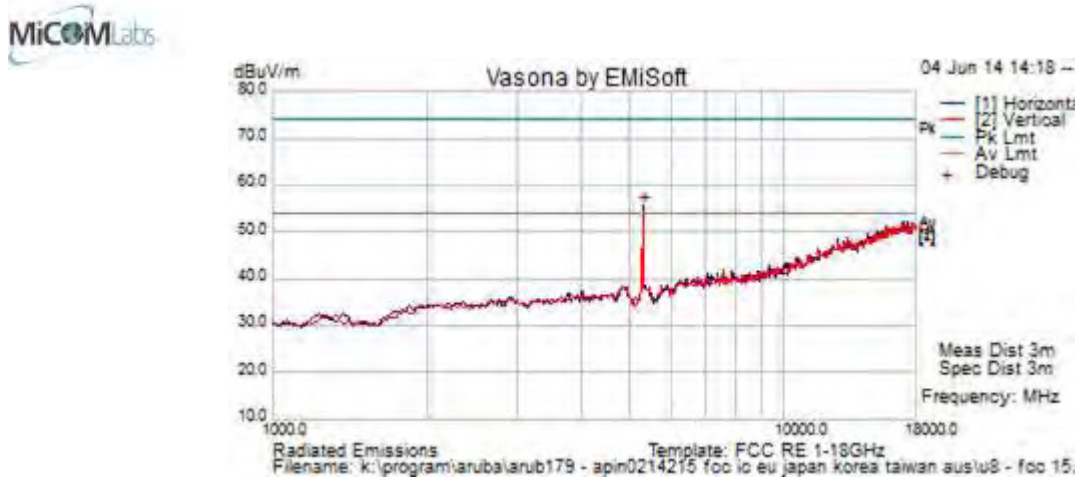

Formally measured emission peaks

Frequency MHz	Raw dBuV	Cable Loss	AF dB	Level dBuV/m	Measurement Type	Pol	Hgt cm	Azt Deg	Limit dBuV/m	Margin dB	Pass /Fail	Comments
5292.585	51.8	6.0	-2.1	55.7	Peak [Scan]	H	100					FUND
Legend: TX = Transmitter Emissions; DIG = Digital Emissions; FUND = Fundamental; WB = Wideband Emission NRB = Non-Restricted Band. Limit = 68.23 dBuV/m; RB = Restricted Band. Limits per 15.205												

This test report may be reproduced in full only. The document may only be updated by MiCOM Labs personnel. Any changes will be noted in the Document History section of the report.



Title: Aruba Networks APIN0214, APIN0215
To: FCC 47 CFR Part 15.407 & IC RSS-210
Serial #: ARUB179-U8 Rev B
Issue Date: 2nd September 2014
Page: 102 of 330

Test Freq.	5320 MHz	Engineer	SB
Variant	802.11a; 6 Mbs	Temp (°C)	18.5
Freq. Range	1000 MHz - 18000 MHz	Rel. Hum.(%)	34
Power Setting	20	Press. (mBars)	1004
Antenna	AP ANT 16	Duty Cycle (%)	99
Test Notes 1	AP214 P302; EUT=Vertical; S/N : CK0000634; MAC: 24 DE C6 CF 5A BA;		
Test Notes 2	POE:PowerDSine 9001GR 55VDC / 350mA;		

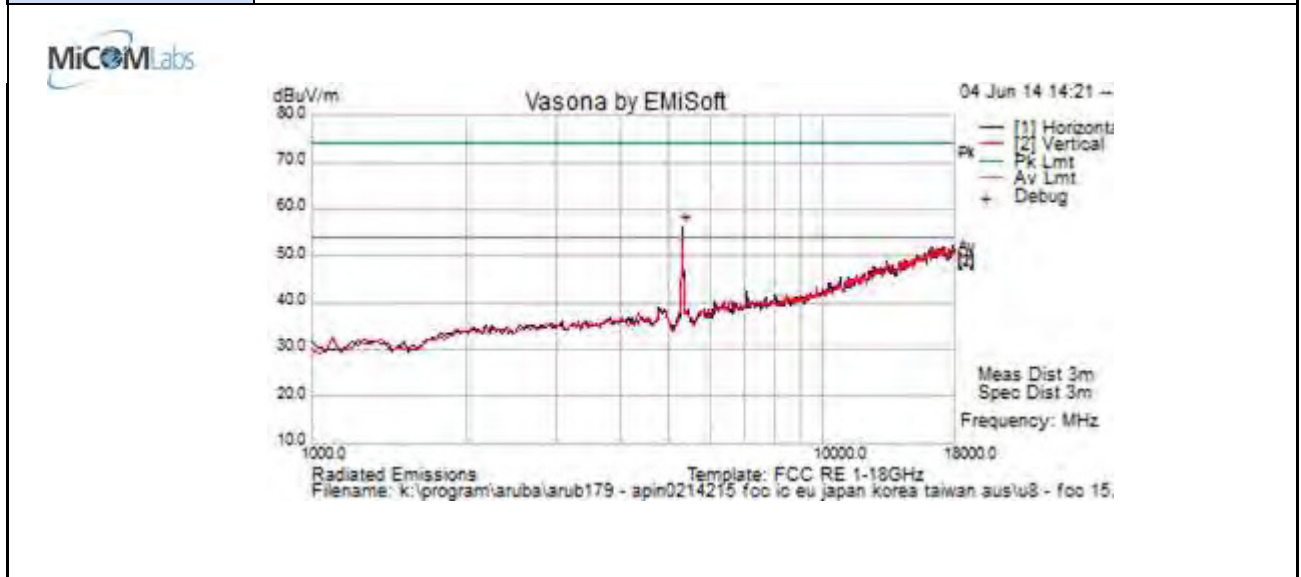

Formally measured emission peaks

Frequency MHz	Raw dBuV	Cable Loss	AF dB	Level dBuV/m	Measurement Type	Pol	Hgt cm	Azt Deg	Limit dBuV/m	Margin dB	Pass /Fail	Comments
5326.653	52.2	6.0	-1.9	56.2	Peak [Scan]	H	100					FUND

Legend:	TX = Transmitter Emissions; DIG = Digital Emissions; FUND = Fundamental; WB = Wideband Emission
	NRB = Non-Restricted Band. Limit = 68.23 dBuV/m; RB = Restricted Band. Limits per 15.205

This test report may be reproduced in full only. The document may only be updated by MiCOM Labs personnel. Any changes will be noted in the Document History section of the report.



Title: Aruba Networks APIN0214, APIN0215
To: FCC 47 CFR Part 15.407 & IC RSS-210
Serial #: ARUB179-U8 Rev B
Issue Date: 2nd September 2014
Page: 103 of 330

Test Freq.	5500 MHz	Engineer	SB
Variant	802.11a; 6 Mbs	Temp (°C)	18.5
Freq. Range	1000 MHz - 18000 MHz	Rel. Hum.(%)	34
Power Setting	20	Press. (mBars)	1004
Antenna	AP ANT 16	Duty Cycle (%)	99
Test Notes 1	AP214 P302; EUT=Vertical; S/N : CK0000634; MAC: 24 DE C6 CF 5A BA;		
Test Notes 2	POE:PowerDSine 9001GR 55VDC / 350mA;		

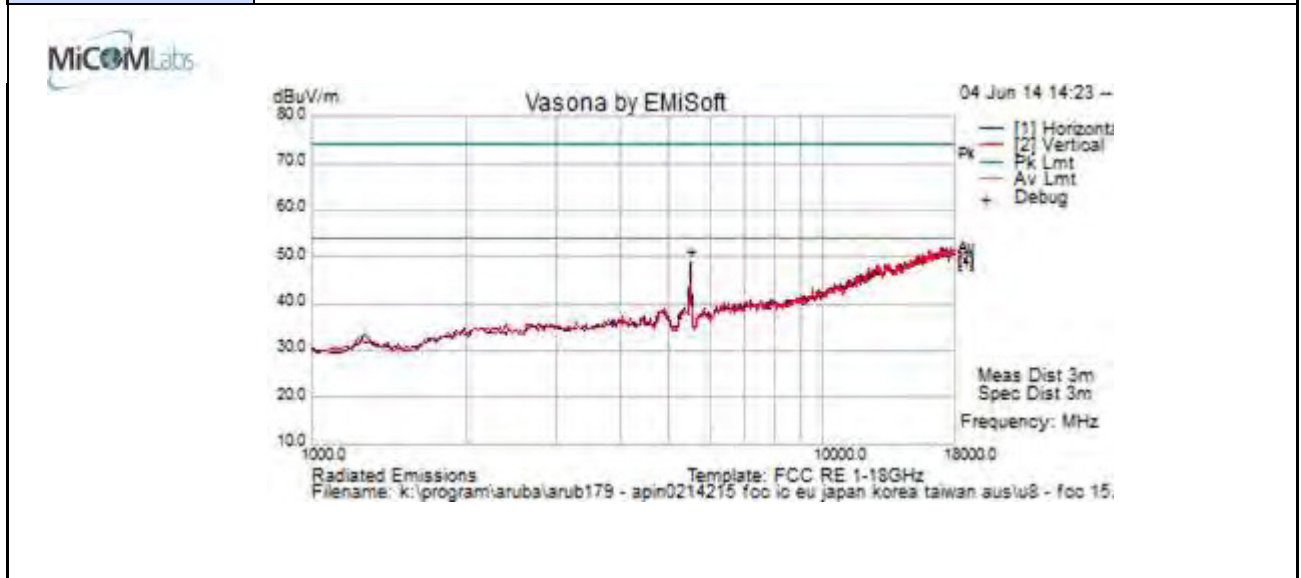

Formally measured emission peaks

Frequency MHz	Raw dBuV	Cable Loss	AF dB	Level dBuV/m	Measurement Type	Pol	Hgt cm	Azt Deg	Limit dBuV/m	Margin dB	Pass /Fail	Comments
5496.994	56.6	6.1	-2.0	60.7	Peak [Scan]	V	100					FUND
Legend: TX = Transmitter Emissions; DIG = Digital Emissions; FUND = Fundamental; WB = Wideband Emission NRB = Non-Restricted Band. Limit = 68.23 dBuV/m; RB = Restricted Band. Limits per 15.205												

This test report may be reproduced in full only. The document may only be updated by MiCOM Labs personnel. Any changes will be noted in the Document History section of the report.



Title: Aruba Networks APIN0214, APIN0215
To: FCC 47 CFR Part 15.407 & IC RSS-210
Serial #: ARUB179-U8 Rev B
Issue Date: 2nd September 2014
Page: 104 of 330

Test Freq.	5580 MHz	Engineer	SB
Variant	802.11a; 6 Mbs	Temp (°C)	18.5
Freq. Range	1000 MHz - 18000 MHz	Rel. Hum.(%)	34
Power Setting	20	Press. (mBars)	1004
Antenna	AP ANT 16	Duty Cycle (%)	99
Test Notes 1	AP214 P302; EUT=Vertical; S/N : CK0000634; MAC: 24 DE C6 CF 5A BA;		
Test Notes 2	POE:PowerDSine 9001GR 55VDC / 350mA;		

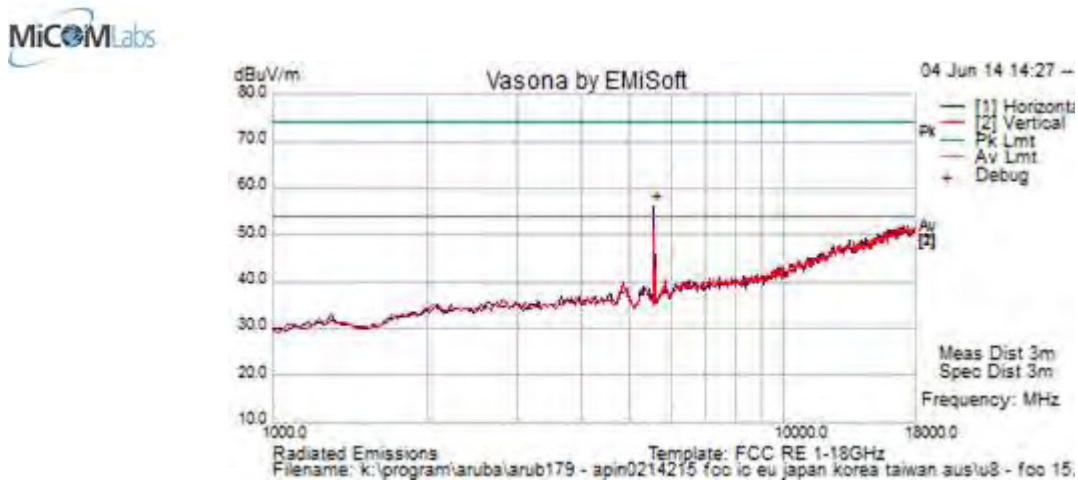

Formally measured emission peaks

Frequency MHz	Raw dBuV	Cable Loss	AF dB	Level dBuV/m	Measurement Type	Pol	Hgt cm	Azt Deg	Limit dBuV/m	Margin dB	Pass /Fail	Comments
5565.130	52.3	6.1	-2.1	56.3	Peak [Scan]	H	100					FUND
Legend: TX = Transmitter Emissions; DIG = Digital Emissions; FUND = Fundamental; WB = Wideband Emission NRB = Non-Restricted Band. Limit = 68.23 dBuV/m; RB = Restricted Band. Limits per 15.205												

This test report may be reproduced in full only. The document may only be updated by MiCOM Labs personnel. Any changes will be noted in the Document History section of the report.



Title: Aruba Networks APIN0214, APIN0215
To: FCC 47 CFR Part 15.407 & IC RSS-210
Serial #: ARUB179-U8 Rev B
Issue Date: 2nd September 2014
Page: 105 of 330

Test Freq.	5700 MHz	Engineer	SB
Variant	802.11a; 6 Mbs	Temp (°C)	18.5
Freq. Range	1000 MHz - 18000 MHz	Rel. Hum.(%)	34
Power Setting	20	Press. (mBars)	1004
Antenna	AP ANT 16	Duty Cycle (%)	99
Test Notes 1	AP214 P302; EUT=Vertical; S/N : CK0000634; MAC: 24 DE C6 CF 5A BA;		
Test Notes 2	POE:PowerDSine 9001GR 55VDC / 350mA;		

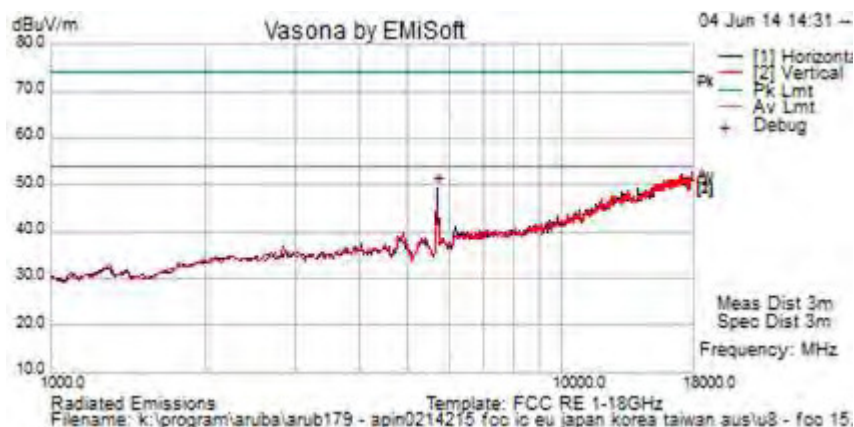

Formally measured emission peaks

Frequency MHz	Raw dBuV	Cable Loss	AF dB	Level dBuV/m	Measurement Type	Pol	Hgt cm	Azt Deg	Limit dBuV/m	Margin dB	Pass /Fail	Comments
5701.403	45.2	6.2	-2.0	49.5	Peak [Scan]	H	100					FUND
Legend: TX = Transmitter Emissions; DIG = Digital Emissions; FUND = Fundamental; WB = Wideband Emission NRB = Non-Restricted Band. Limit = 68.23 dBuV/m; RB = Restricted Band. Limits per 15.205												

This test report may be reproduced in full only. The document may only be updated by MiCOM Labs personnel. Any changes will be noted in the Document History section of the report.



Antenna AP-ANT-16 - Radiated Band-Edge

Peak Limit 74.0 dBµV/m, Average Limit 54.0 dBµV/m

		5350 MHz		
		dBµV		Power Setting
Operational Mode	Operating Frequency (MHz)	Peak	Average	
a	5320.0	58.67	44.76	20.0
n HT-20	5320.0	58.24	44.68	20.0
n HT-40	5310.0	63.41	48.19	20.0
ac-80	5290.0	68.31	51.61	20.0

		5470 MHz		
		dBµV		Power Setting
Operational Mode	Operating Frequency	Peak	Average	
a	5500.0	56.84	44.35	20.0
n HT-20	5500.0	56.73	44.26	20.0
n HT-40	5510.0	67.81	52.73	20.0
ac-80	5530.0	68.32	52.83	20.0

This test report may be reproduced in full only. The document may only be updated by MiCOM Labs personnel. Any changes will be noted in the Document History section of the report.



Title: Aruba Networks APIN0214, APIN0215
To: FCC 47 CFR Part 15.407 & IC RSS-210
Serial #: ARUB179-U8 Rev B
Issue Date: 2nd September 2014
Page: 107 of 330

6.1.2.5. AP-ANT-18 – Spurious Emissions

Test Freq.	5260 MHz	Engineer	SB
Variant	802.11a; 6 Mbs	Temp (°C)	18.5
Freq. Range	1000 MHz - 18000 MHz	Rel. Hum.(%)	34
Power Setting	20	Press. (mBars)	1004
Antenna	AP ANT 18	Duty Cycle (%)	99
Test Notes 1	AP214 P302; EUT=Vertical; S/N : CK0000634; MAC: 24 DE C6 CF 5A BA;		
Test Notes 2	POE:PowerDSine 9001GR 55VDC / 350mA;		

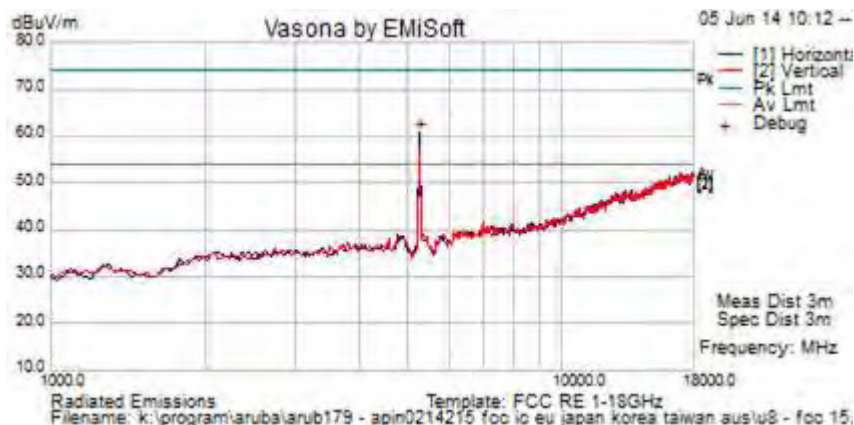

Formally measured emission peaks

Frequency MHz	Raw dBuV	Cable Loss	AF dB	Level dBuV/m	Measurement Type	Pol	Hgt cm	Azt Deg	Limit dBuV/m	Margin dB	Pass /Fail	Comments
5258.517	67.0	5.9	-2.2	70.7	Peak [Scan]	H	100					FUND

Legend: TX = Transmitter Emissions; DIG = Digital Emissions; FUND = Fundamental; WB = Wideband Emission
 NRB = Non-Restricted Band. Limit = 68.23 dBuV/m; RB = Restricted Band. Limits per 15.205

This test report may be reproduced in full only. The document may only be updated by MiCOM Labs personnel. Any changes will be noted in the Document History section of the report.



Title: Aruba Networks APIN0214, APIN0215
To: FCC 47 CFR Part 15.407 & IC RSS-210
Serial #: ARUB179-U8 Rev B
Issue Date: 2nd September 2014
Page: 108 of 330

Test Freq.	5300 MHz	Engineer	SB
Variant	802.11a; 6 Mbs	Temp (°C)	18.5
Freq. Range	1000 MHz - 18000 MHz	Rel. Hum.(%)	34
Power Setting	20	Press. (mBars)	1004
Antenna	AP ANT 18	Duty Cycle (%)	99
Test Notes 1	AP214 P302; EUT=Vertical; S/N : CK0000634; MAC: 24 DE C6 CF 5A BA;		
Test Notes 2	POE:PowerDSine 9001GR 55VDC / 350mA;		

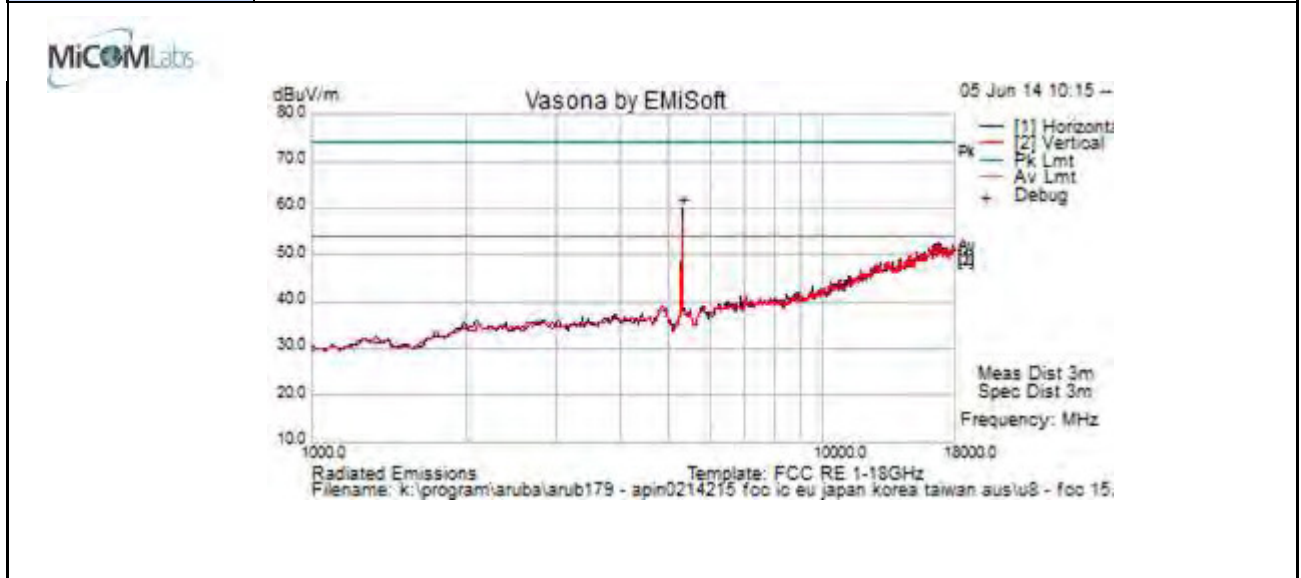

Formally measured emission peaks

Frequency MHz	Raw dBuV	Cable Loss	AF dB	Level dBuV/m	Measurement Type	Pol	Hgt cm	Azt Deg	Limit dBuV/m	Margin dB	Pass /Fail	Comments
5292.585	63.2	6.0	-2.1	67.1	Peak [Scan]	H	100					FUND
Legend: TX = Transmitter Emissions; DIG = Digital Emissions; FUND = Fundamental; WB = Wideband Emission NRB = Non-Restricted Band. Limit = 68.23 dBuV/m; RB = Restricted Band. Limits per 15.205												

This test report may be reproduced in full only. The document may only be updated by MiCOM Labs personnel. Any changes will be noted in the Document History section of the report.



Title: Aruba Networks APIN0214, APIN0215
To: FCC 47 CFR Part 15.407 & IC RSS-210
Serial #: ARUB179-U8 Rev B
Issue Date: 2nd September 2014
Page: 109 of 330

Test Freq.	5320 MHz	Engineer	SB
Variant	802.11a; 6 Mbs	Temp (°C)	18.5
Freq. Range	1000 MHz - 18000 MHz	Rel. Hum.(%)	34
Power Setting	20	Press. (mBars)	1004
Antenna	AP ANT 18	Duty Cycle (%)	99
Test Notes 1	AP214 P302; EUT=Vertical; S/N : CK0000634; MAC: 24 DE C6 CF 5A BA;		
Test Notes 2	POE:PowerDSine 9001GR 55VDC / 350mA;		

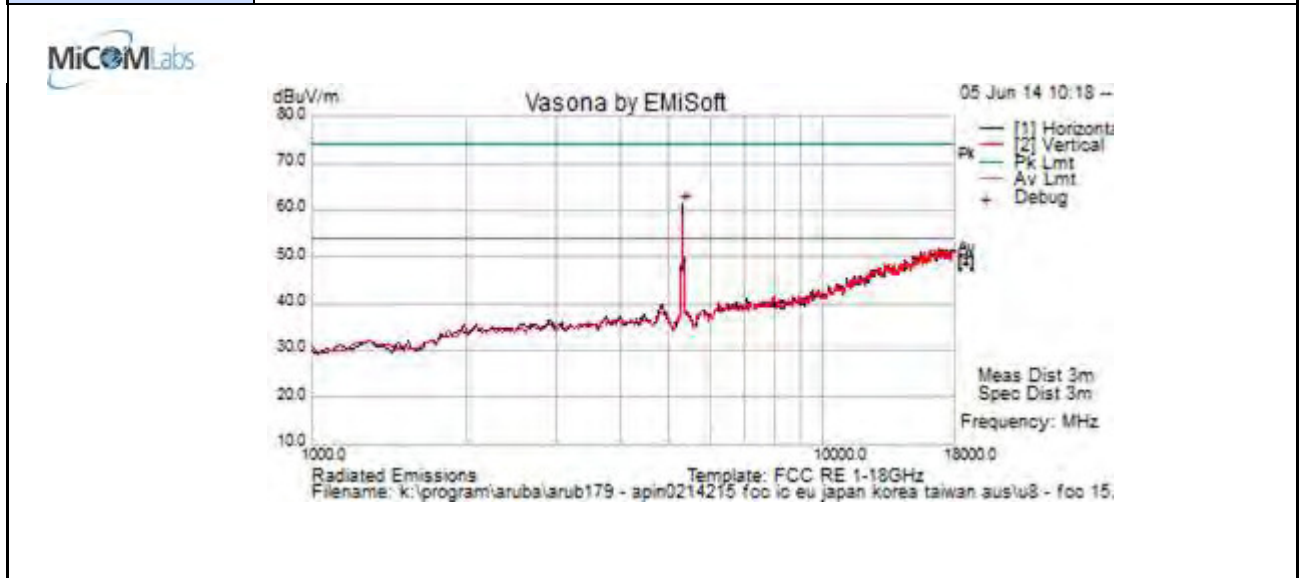

Formally measured emission peaks

Frequency MHz	Raw dBuV	Cable Loss	AF dB	Level dBuV/m	Measurement Type	Pol	Hgt cm	Azt Deg	Limit dBuV/m	Margin dB	Pass /Fail	Comments
5326.653	63.2	6.0	-1.9	67.2	Peak [Scan]	H	100					FUND

Legend:	TX = Transmitter Emissions; DIG = Digital Emissions; FUND = Fundamental; WB = Wideband Emission
	NRB = Non-Restricted Band. Limit = 68.23 dBuV/m; RB = Restricted Band. Limits per 15.205

This test report may be reproduced in full only. The document may only be updated by MiCOM Labs personnel. Any changes will be noted in the Document History section of the report.



Title: Aruba Networks APIN0214, APIN0215
To: FCC 47 CFR Part 15.407 & IC RSS-210
Serial #: ARUB179-U8 Rev B
Issue Date: 2nd September 2014
Page: 110 of 330

Test Freq.	5500 MHz	Engineer	SB
Variant	802.11a; 6 Mbs	Temp (°C)	18.5
Freq. Range	1000 MHz - 18000 MHz	Rel. Hum.(%)	34
Power Setting	20	Press. (mBars)	1004
Antenna	AP ANT 18	Duty Cycle (%)	99
Test Notes 1	AP214 P302; EUT=Vertical; S/N : CK0000634; MAC: 24 DE C6 CF 5A BA;		
Test Notes 2	POE:PowerDSine 9001GR 55VDC / 350mA;		

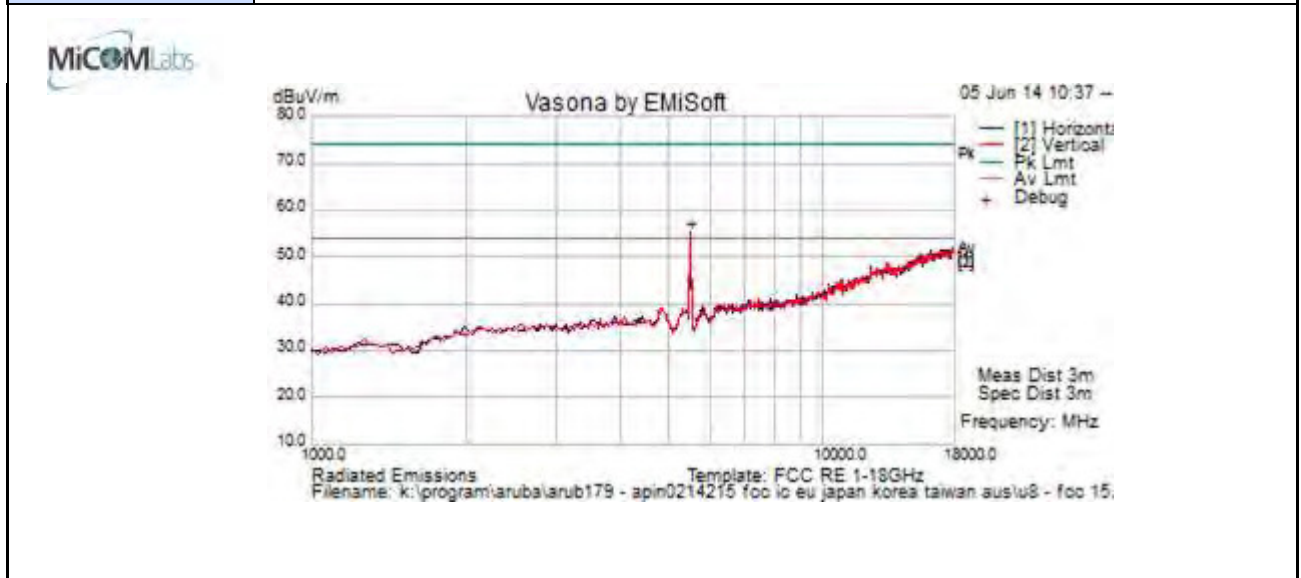

Formally measured emission peaks

Frequency MHz	Raw dBuV	Cable Loss	AF dB	Level dBuV/m	Measurement Type	Pol	Hgt cm	Azt Deg	Limit dBuV/m	Margin dB	Pass /Fail	Comments
5496.994	56.6	6.1	-2.0	60.7	Peak [Scan]	H	100					FUND
Legend: TX = Transmitter Emissions; DIG = Digital Emissions; FUND = Fundamental; WB = Wideband Emission NRB = Non-Restricted Band. Limit = 68.23 dBuV/m; RB = Restricted Band. Limits per 15.205												

This test report may be reproduced in full only. The document may only be updated by MiCOM Labs personnel. Any changes will be noted in the Document History section of the report.



Title: Aruba Networks APIN0214, APIN0215
To: FCC 47 CFR Part 15.407 & IC RSS-210
Serial #: ARUB179-U8 Rev B
Issue Date: 2nd September 2014
Page: 111 of 330

Test Freq.	5580 MHz	Engineer	SB
Variant	802.11a; 6 Mbs	Temp (°C)	18.5
Freq. Range	1000 MHz - 18000 MHz	Rel. Hum.(%)	34
Power Setting	20	Press. (mBars)	1004
Antenna	AP ANT 18	Duty Cycle (%)	99
Test Notes 1	AP214 P302; EUT=Vertical; S/N : CK0000634; MAC: 24 DE C6 CF 5A BA;		
Test Notes 2	POE:PowerDSine 9001GR 55VDC / 350mA;		

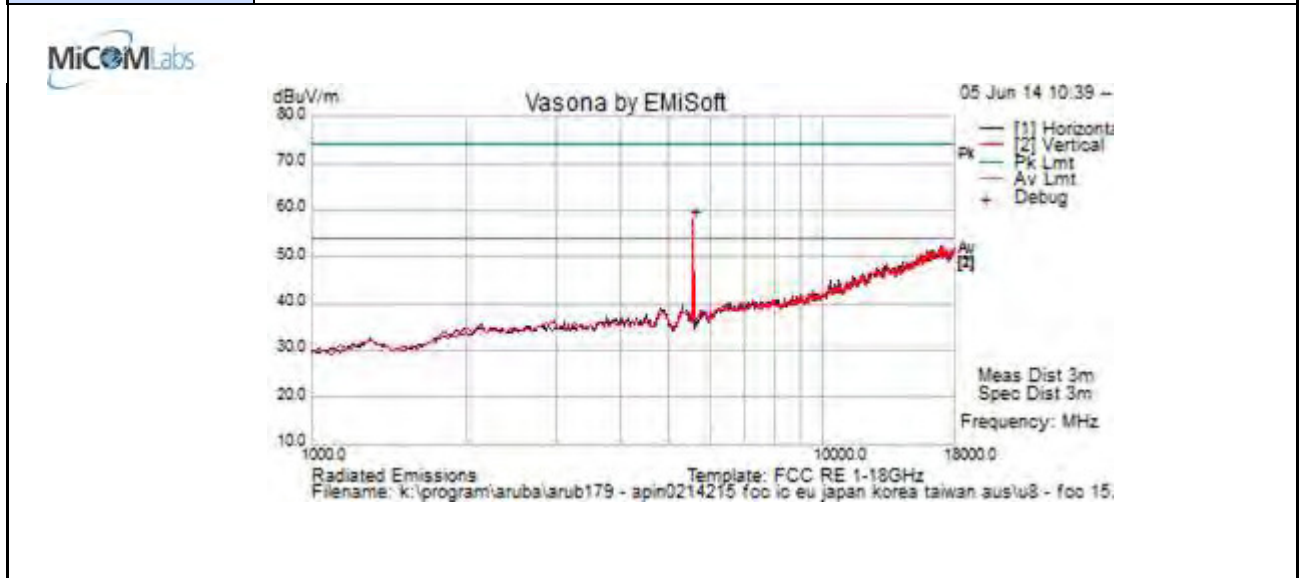

Formally measured emission peaks

Frequency MHz	Raw dBuV	Cable Loss	AF dB	Level dBuV/m	Measurement Type	Pol	Hgt cm	Azt Deg	Limit dBuV/m	Margin dB	Pass /Fail	Comments
5565.130	59.7	6.1	-2.1	63.7	Peak [Scan]	H	100					FUND
Legend: TX = Transmitter Emissions; DIG = Digital Emissions; FUND = Fundamental; WB = Wideband Emission NRB = Non-Restricted Band. Limit = 68.23 dBuV/m; RB = Restricted Band. Limits per 15.205												

This test report may be reproduced in full only. The document may only be updated by MiCOM Labs personnel. Any changes will be noted in the Document History section of the report.



Title: Aruba Networks APIN0214, APIN0215
To: FCC 47 CFR Part 15.407 & IC RSS-210
Serial #: ARUB179-U8 Rev B
Issue Date: 2nd September 2014
Page: 112 of 330

Test Freq.	5700 MHz	Engineer	SB
Variant	802.11a; 6 Mbs	Temp (°C)	18.5
Freq. Range	1000 MHz - 18000 MHz	Rel. Hum.(%)	34
Power Setting	20	Press. (mBars)	1004
Antenna	AP ANT 18	Duty Cycle (%)	99
Test Notes 1	AP214 P302; EUT=Vertical; S/N : CK0000634; MAC: 24 DE C6 CF 5A BA;		
Test Notes 2	POE:PowerDSine 9001GR 55VDC / 350mA;		

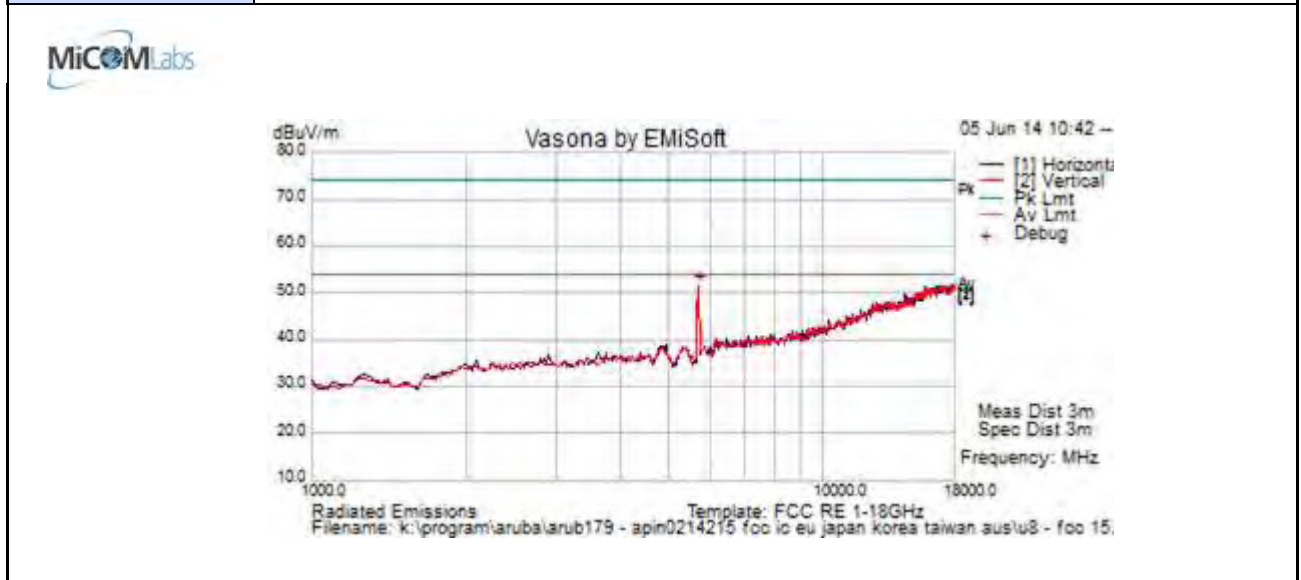

Formally measured emission peaks

Frequency MHz	Raw dBuV	Cable Loss	AF dB	Level dBuV/m	Measurement Type	Pol	Hgt cm	Azt Deg	Limit dBuV/m	Margin dB	Pass /Fail	Comments
5701.403	47.3	6.2	-2.0	51.5	Peak [Scan]	H	100					FUND
Legend: TX = Transmitter Emissions; DIG = Digital Emissions; FUND = Fundamental; WB = Wideband Emission NRB = Non-Restricted Band. Limit = 68.23 dBuV/m; RB = Restricted Band. Limits per 15.205												

This test report may be reproduced in full only. The document may only be updated by MiCOM Labs personnel. Any changes will be noted in the Document History section of the report.



Antenna AP-ANT-18 - Radiated Band-Edge

Peak Limit 74.0 dBµV/m, Average Limit 54.0 dBµV/m

		5350 MHz		
		dBµV		Power Setting
Operational Mode	Operating Frequency (MHz)	Peak	Average	
a	5320.0	61.60	47.58	20.0
n HT-20	5320.0	62.30	47.50	20.0
n HT-40	5310.0	67.23	53.46	20.0
ac-80	5290.0	70.94	52.99	17.0

		5470 MHz		
		dBµV		Power Setting
Operational Mode	Operating Frequency	Peak	Average	
a	5500.0	60.41	47.42	20.0
n HT-20	5500.0	60.61	47.42	20.0
n HT-40	5510.0	65.99	48.29	20.0
ac-80	5530.0	71.44	53.90	20.0

This test report may be reproduced in full only. The document may only be updated by MiCOM Labs personnel. Any changes will be noted in the Document History section of the report.



Title: Aruba Networks APIN0214, APIN0215
To: FCC 47 CFR Part 15.407 & IC RSS-210
Serial #: ARUB179-U8 Rev B
Issue Date: 2nd September 2014
Page: 114 of 330

6.1.2.6. AP-ANT-19 – Spurious Emissions

Test Freq.	5260 MHz	Engineer	SB
Variant	802.11a; 6 Mbs	Temp (°C)	18.5
Freq. Range	1000 MHz - 18000 MHz	Rel. Hum.(%)	34
Power Setting	20	Press. (mBars)	1004
Antenna	AP ANT 19	Duty Cycle (%)	99
Test Notes 1	AP214 P302; EUT=Vertical; S/N : CK0000634; MAC: 24 DE C6 CF 5A BA;		
Test Notes 2	POE:PowerDSine 9001GR 55VDC / 350mA;		

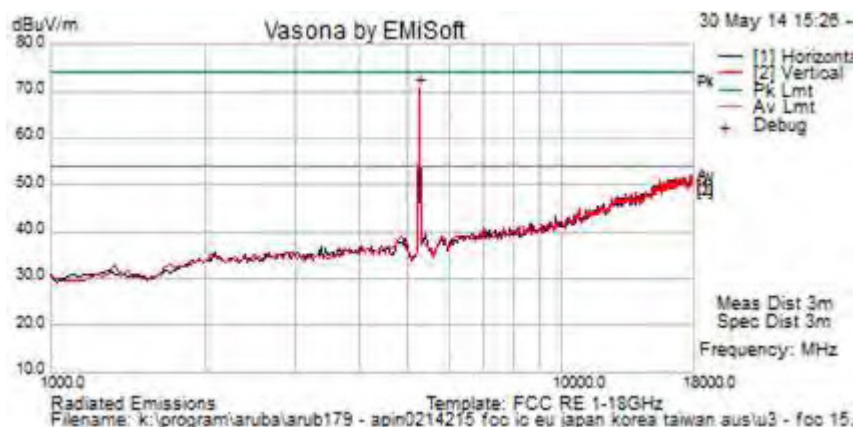

Formally measured emission peaks

Frequency MHz	Raw dBuV	Cable Loss	AF dB	Level dBuV/m	Measurement Type	Pol	Hgt cm	Azt Deg	Limit dBuV/m	Margin dB	Pass /Fail	Comments
5258.517	67.0	5.9	-2.2	70.7	Peak [Scan]	V	100					FUND
Legend: TX = Transmitter Emissions; DIG = Digital Emissions; FUND = Fundamental; WB = Wideband Emission NRB = Non-Restricted Band. Limit = 68.23 dBuV/m; RB = Restricted Band. Limits per 15.205												

This test report may be reproduced in full only. The document may only be updated by MiCOM Labs personnel. Any changes will be noted in the Document History section of the report.



Title: Aruba Networks APIN0214, APIN0215
To: FCC 47 CFR Part 15.407 & IC RSS-210
Serial #: ARUB179-U8 Rev B
Issue Date: 2nd September 2014
Page: 115 of 330

Test Freq.	5300 MHz	Engineer	SB
Variant	802.11a; 6 Mbs	Temp (°C)	18.5
Freq. Range	1000 MHz - 18000 MHz	Rel. Hum.(%)	34
Power Setting	20	Press. (mBars)	1004
Antenna	AP ANT 19	Duty Cycle (%)	99
Test Notes 1	AP214 P302; EUT=Vertical; S/N : CK0000634; MAC: 24 DE C6 CF 5A BA;		
Test Notes 2	POE:PowerDSine 9001GR 55VDC / 350mA;		

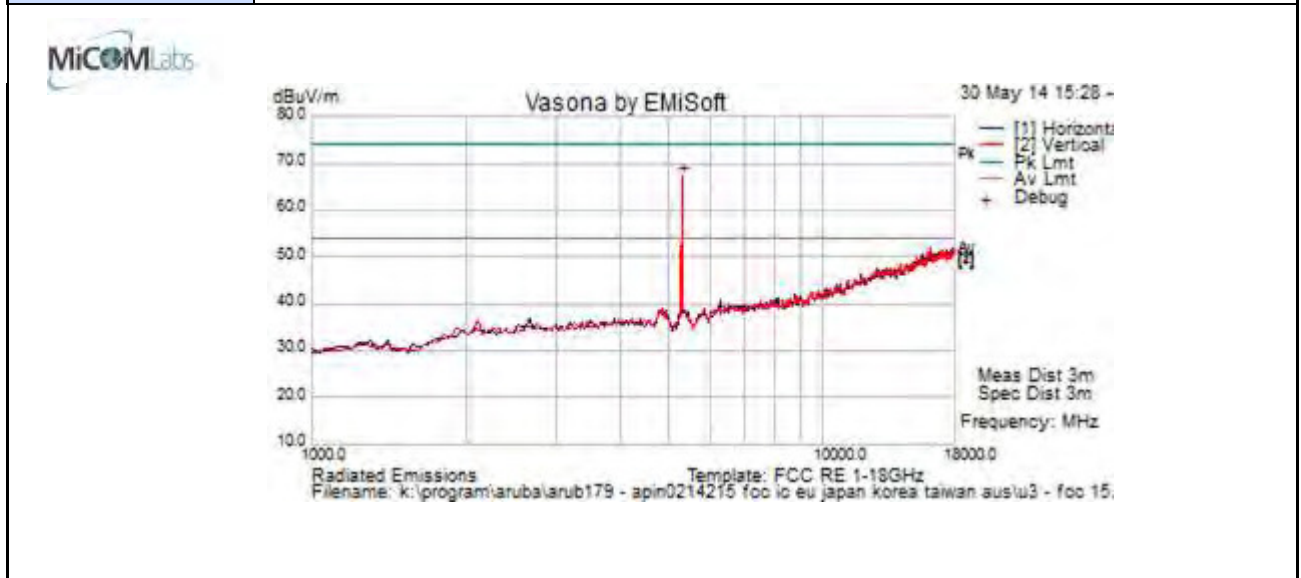

Formally measured emission peaks

Frequency MHz	Raw dBuV	Cable Loss	AF dB	Level dBuV/m	Measurement Type	Pol	Hgt cm	Azt Deg	Limit dBuV/m	Margin dB	Pass /Fail	Comments
5292.585	63.2	6.0	-2.1	67.1	Peak [Scan]	V	100					FUND
Legend: TX = Transmitter Emissions; DIG = Digital Emissions; FUND = Fundamental; WB = Wideband Emission NRB = Non-Restricted Band. Limit = 68.23 dBuV/m; RB = Restricted Band. Limits per 15.205												

This test report may be reproduced in full only. The document may only be updated by MiCOM Labs personnel. Any changes will be noted in the Document History section of the report.



Title: Aruba Networks APIN0214, APIN0215
To: FCC 47 CFR Part 15.407 & IC RSS-210
Serial #: ARUB179-U8 Rev B
Issue Date: 2nd September 2014
Page: 116 of 330

Test Freq.	5320 MHz	Engineer	SB
Variant	802.11a; 6 Mbs	Temp (°C)	18.5
Freq. Range	1000 MHz - 18000 MHz	Rel. Hum.(%)	34
Power Setting	20	Press. (mBars)	1004
Antenna	AP ANT 19	Duty Cycle (%)	99
Test Notes 1	AP214 P302; EUT=Vertical; S/N : CK0000634; MAC: 24 DE C6 CF 5A BA;		
Test Notes 2	POE:PowerDSine 9001GR 55VDC / 350mA;		

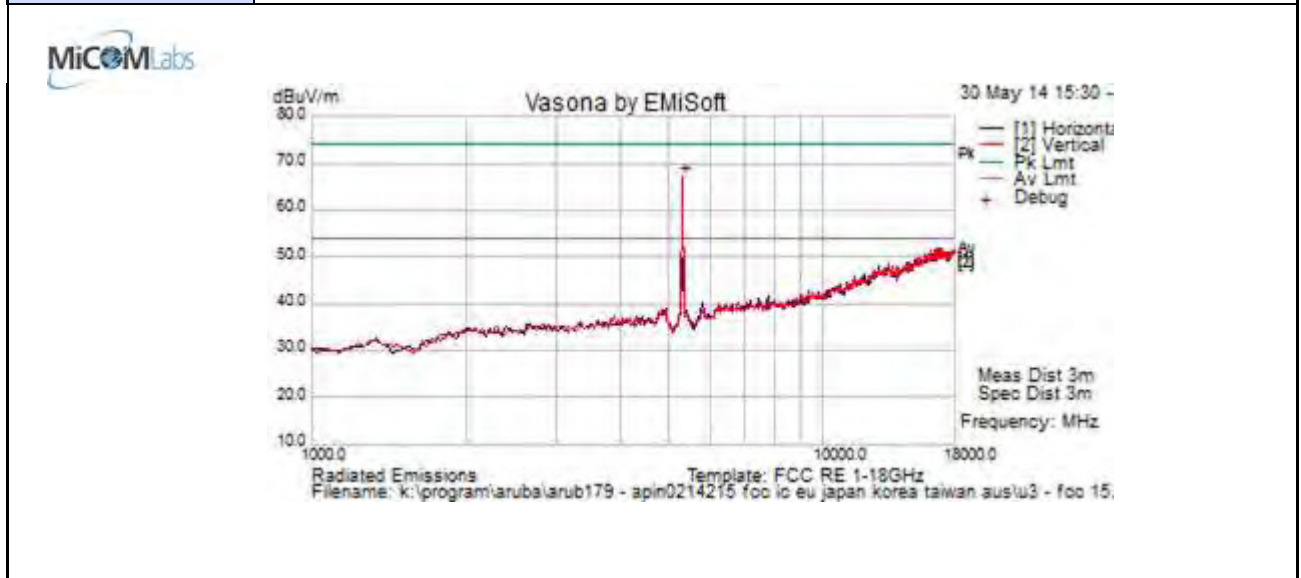

Formally measured emission peaks

Frequency MHz	Raw dBuV	Cable Loss	AF dB	Level dBuV/m	Measurement Type	Pol	Hgt cm	Azt Deg	Limit dBuV/m	Margin dB	Pass /Fail	Comments
5326.653	63.2	6.0	-1.9	67.2	Peak [Scan]	V	100					FUND
Legend: TX = Transmitter Emissions; DIG = Digital Emissions; FUND = Fundamental; WB = Wideband Emission NRB = Non-Restricted Band. Limit = 68.23 dBuV/m; RB = Restricted Band. Limits per 15.205												

This test report may be reproduced in full only. The document may only be updated by MiCOM Labs personnel. Any changes will be noted in the Document History section of the report.



Title: Aruba Networks APIN0214, APIN0215
To: FCC 47 CFR Part 15.407 & IC RSS-210
Serial #: ARUB179-U8 Rev B
Issue Date: 2nd September 2014
Page: 117 of 330

Test Freq.	5500 MHz	Engineer	SB
Variant	802.11a; 6 Mbs	Temp (°C)	18.5
Freq. Range	1000 MHz - 18000 MHz	Rel. Hum.(%)	34
Power Setting	20	Press. (mBars)	1004
Antenna	AP ANT 19	Duty Cycle (%)	99
Test Notes 1	AP214 P302; EUT=Vertical; S/N : CK0000634; MAC: 24 DE C6 CF 5A BA;		
Test Notes 2	POE:PowerDSine 9001GR 55VDC / 350mA;		

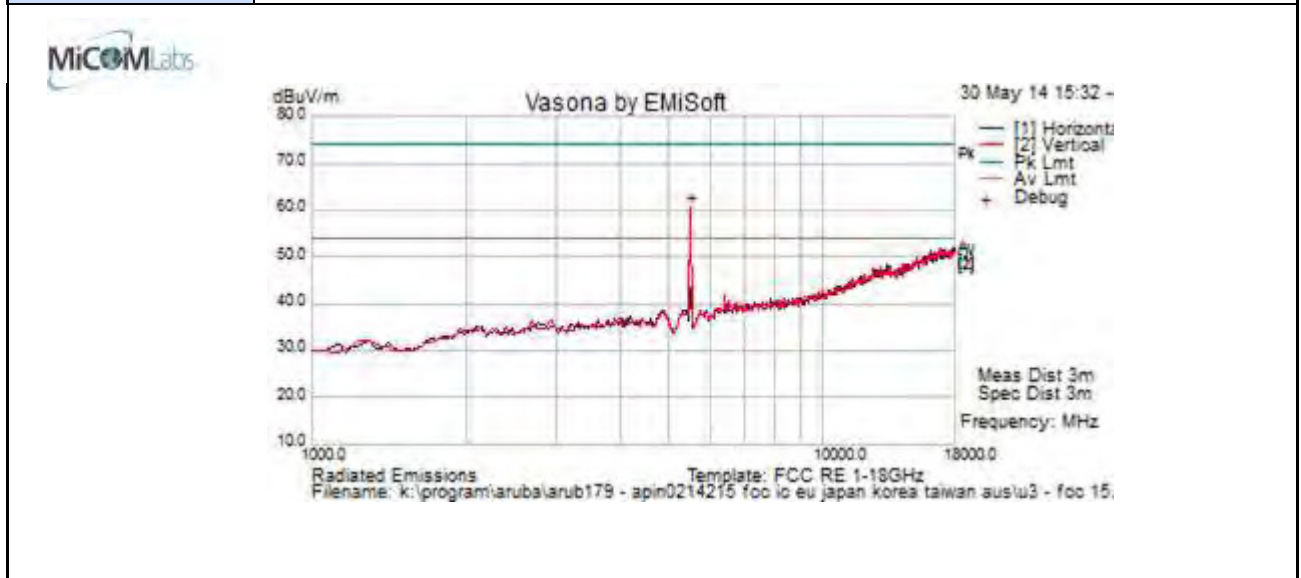

Formally measured emission peaks

Frequency MHz	Raw dBuV	Cable Loss	AF dB	Level dBuV/m	Measurement Type	Pol	Hgt cm	Azt Deg	Limit dBuV/m	Margin dB	Pass /Fail	Comments
5496.994	56.6	6.1	-2.0	60.7	Peak [Scan]	V	100					FUND
Legend: TX = Transmitter Emissions; DIG = Digital Emissions; FUND = Fundamental; WB = Wideband Emission NRB = Non-Restricted Band. Limit = 68.23 dBuV/m; RB = Restricted Band. Limits per 15.205												

This test report may be reproduced in full only. The document may only be updated by MiCOM Labs personnel. Any changes will be noted in the Document History section of the report.



Title: Aruba Networks APIN0214, APIN0215
To: FCC 47 CFR Part 15.407 & IC RSS-210
Serial #: ARUB179-U8 Rev B
Issue Date: 2nd September 2014
Page: 118 of 330

Test Freq.	5580 MHz	Engineer	SB
Variant	802.11a; 6 Mbs	Temp (°C)	18.5
Freq. Range	1000 MHz - 18000 MHz	Rel. Hum.(%)	34
Power Setting	20	Press. (mBars)	1004
Antenna	AP ANT 19	Duty Cycle (%)	99
Test Notes 1	AP214 P302; EUT=Vertical; S/N : CK0000634; MAC: 24 DE C6 CF 5A BA;		
Test Notes 2	POE:PowerDSine 9001GR 55VDC / 350mA;		

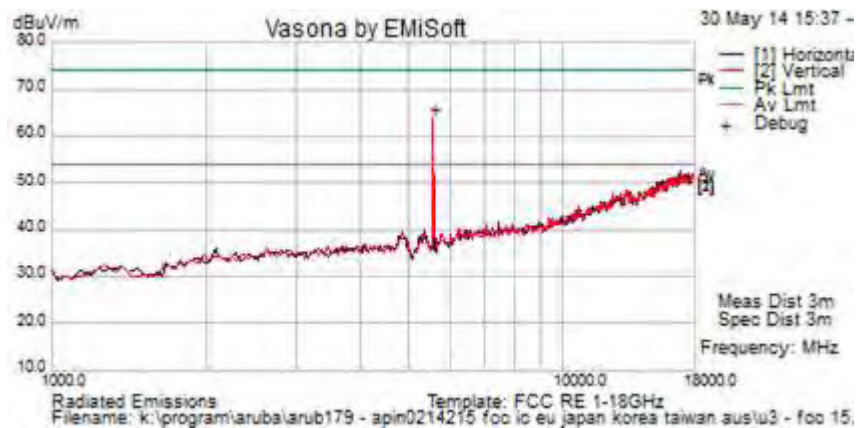

Formally measured emission peaks

Frequency MHz	Raw dBuV	Cable Loss	AF dB	Level dBuV/m	Measurement Type	Pol	Hgt cm	Azt Deg	Limit dBuV/m	Margin dB	Pass /Fail	Comments
5565.130	59.7	6.1	-2.1	63.7	Peak [Scan]	V	100					FUND
Legend: TX = Transmitter Emissions; DIG = Digital Emissions; FUND = Fundamental; WB = Wideband Emission NRB = Non-Restricted Band. Limit = 68.23 dBuV/m; RB = Restricted Band. Limits per 15.205												

This test report may be reproduced in full only. The document may only be updated by MiCOM Labs personnel. Any changes will be noted in the Document History section of the report.



Title: Aruba Networks APIN0214, APIN0215
To: FCC 47 CFR Part 15.407 & IC RSS-210
Serial #: ARUB179-U8 Rev B
Issue Date: 2nd September 2014
Page: 119 of 330

Test Freq.	5700 MHz	Engineer	SB
Variant	802.11a; 6 Mbs	Temp (°C)	18.5
Freq. Range	1000 MHz - 18000 MHz	Rel. Hum.(%)	34
Power Setting	20	Press. (mBars)	1004
Antenna	AP ANT 19	Duty Cycle (%)	99
Test Notes 1	AP214 P302; EUT=Vertical; S/N : CK0000634; MAC: 24 DE C6 CF 5A BA;		
Test Notes 2	POE:PowerDSine 9001GR 55VDC / 350mA;		

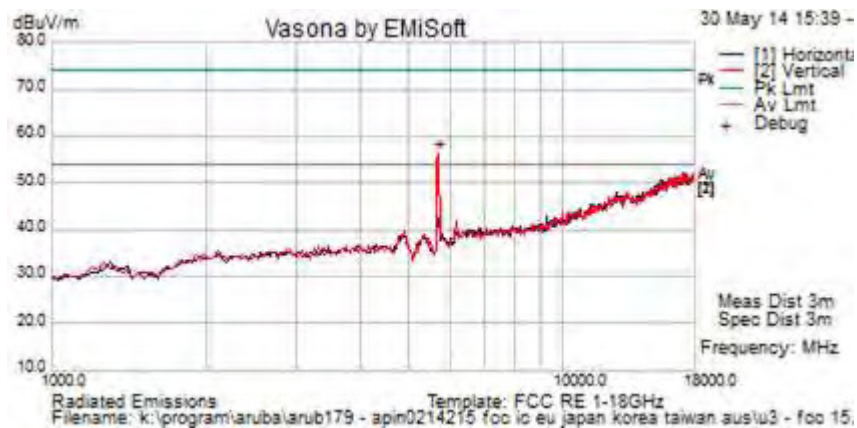

Formally measured emission peaks

Frequency MHz	Raw dBuV	Cable Loss	AF dB	Level dBuV/m	Measurement Type	Pol	Hgt cm	Azt Deg	Limit dBuV/m	Margin dB	Pass /Fail	Comments
5701.403	52.1	6.2	-2.0	56.3	Peak [Scan]	V	100					FUND
Legend: TX = Transmitter Emissions; DIG = Digital Emissions; FUND = Fundamental; WB = Wideband Emission NRB = Non-Restricted Band. Limit = 68.23 dBuV/m; RB = Restricted Band. Limits per 15.205												

This test report may be reproduced in full only. The document may only be updated by MiCOM Labs personnel. Any changes will be noted in the Document History section of the report.



Antenna AP-ANT-19 - Radiated Band-Edge

Peak Limit 74.0 dBµV/m, Average Limit 54.0 dBµV/m

		5350 MHz		
		dBµV		Power Setting
Operational Mode	Operating Frequency (MHz)	Peak	Average	
a	5320.0	64.18	53.22	17.0
n HT-20	5320.0	64.41	53.22	17.0
n HT-40	5310.0	69.33	53.58	16.75
ac-80	5290.0	73.87	51.49	16.75

		5470 MHz		
		dBµV		Power Setting
Operational Mode	Operating Frequency	Peak	Average	
a	5500.0	64.37	52.90	20.0
n HT-20	5500.0	64.90	52.90	20.0
n HT-40	5510.0	69.75	52.35	20.0
ac-80	5530.0	68.43	53.38	14.0

This test report may be reproduced in full only. The document may only be updated by MiCOM Labs personnel. Any changes will be noted in the Document History section of the report.



Title: Aruba Networks APIN0214, APIN0215
To: FCC 47 CFR Part 15.407 & IC RSS-210
Serial #: ARUB179-U8 Rev B
Issue Date: 2nd September 2014
Page: 121 of 330

6.1.2.7. Digital Emissions (30M-1 GHz)

FCC, Part 15 Subpart C §15.205/ §15.209
Industry Canada RSS-210 §2.2

Test Procedure

Testing 30M-1 GHz was performed in a 3-meter anechoic chamber using a CISPR compliant receiver. Preliminary radiated emissions were measured on every azimuth and with the receiving antenna in both horizontal and vertical polarizations. To further maximize emissions the receive antenna was varied between 1 and 4 meters. The emissions are recorded with receiver in peak hold mode. Emissions closest to the limits are measured in the quasi-peak mode with the tuned receiver using a bandwidth of 120 kHz. Only the highest emissions relative to the limit are listed. The anechoic chamber test set-up is identified in Section 6 Test Set-Up Photographs.

The EUT had two methods of powering on ac/dc converter and Power over Ethernet (POE). Both modes were tested for emissions below 1GHz.

Field Strength Calculation

The field strength is calculated by adding the Antenna Factor and Cable Loss, and subtracting Amplifier Gain from the measured reading. In this test facility, the Antenna Factor, Cable Loss, and Amplifier Gains are loaded into the Rohde & Schwarz Receiver and the corrected field strength can be read directly on the receiver.

$$FS = R + AF + CORR$$

where:

FS = Field Strength
R = Measured Receiver Input Amplitude
AF = Antenna Factor
CORR = Correction Factor = CL – AG + NFL
CL = Cable Loss
AG = Amplifier Gain

For example:

Given a Receiver input reading of 51.5dB μ V; Antenna Factor of 8.5dB; Cable Loss of 1.3dB; Falloff Factor of 0dB, an Amplifier Gain of 26dB and Notch Filter Loss of 1dB. The Field Strength of the measured emission is:

$$FS = 51.5 + 8.5 + 1.3 - 26.0 + 1 = 36.3\text{dB}\mu\text{V/m}$$

Conversion between dB μ V/m (or dB μ V) and μ V/m (or μ V) are done as:

$$\text{Level (dB}\mu\text{V/m)} = 20 * \text{Log (level (\mu\text{V/m}))}$$

$$40 \text{ dB}\mu\text{V/m} = 100\mu\text{V/m}$$

$$48 \text{ dB}\mu\text{V/m} = 250\mu\text{V/m}$$

This test report may be reproduced in full only. The document may only be updated by MiCOM Labs personnel. Any changes will be noted in the Document History section of the report.



Title: Aruba Networks APIN0214, APIN0215
To: FCC 47 CFR Part 15.407 & IC RSS-210
Serial #: ARUB179-U8 Rev B
Issue Date: 2nd September 2014
Page: 122 of 330

APIN0214

Test Freq.	2437 MHz	Engineer	SB
Variant	Digital Emissions	Temp (°C)	24
Freq. Range	30 MHz - 1000 MHz	Rel. Hum.(%)	32
Power Setting	19	Press. (mBars)	997
Antenna	AP ANT 1B	Duty Cycle (%)	99
Test Notes 1	AP214 P302; EUT=Vertical; S/N : CK0000634; MAC: 24 DE C6 CF 5A BA;		
Test Notes 2	Sunny Switching Adapter; Model: SYS1357-1812; 12VDC / 1/5A;		

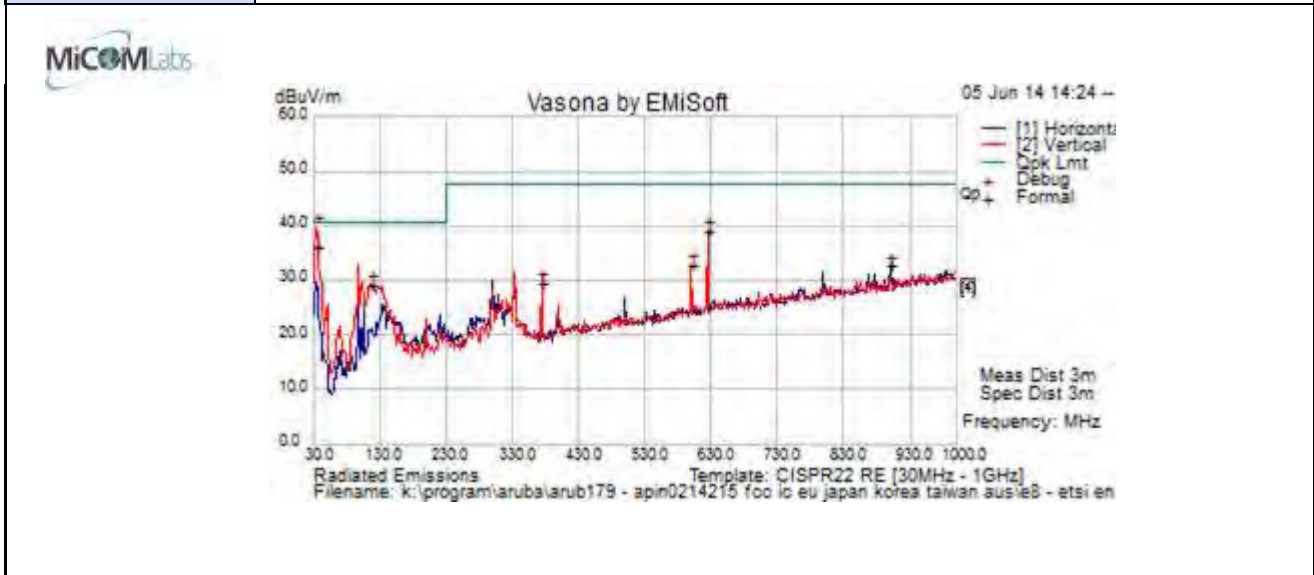

Formally measured emission peaks

Frequency MHz	Raw dBuV	Cable Loss	AF dB	Level dBuV/m	Measurement Type	Pol	Hgt cm	Azt Deg	Limit dBuV/m	Margin dB	Pass /Fail	Comments
35.732	46.3	3.6	-13.8	36.1	Quasi Max	V	97	361	40.5	-4.4	Pass	
624.991	43.4	6.3	-10.6	39.1	Peak [Scan]	V	98	361	47.5	-8.4	Pass	
600.005	38.0	6.2	-11.3	32.9	Peak [Scan]	H	98	361	47.5	-14.6	Pass	
116.099	42.6	4.2	-17.6	29.2	Peak [Scan]	V	98	361	40.5	-11.3	Pass	
374.987	39.4	5.4	-15.3	29.5	Peak [Scan]	V	98	361	47.5	-18.0	Pass	
900.957	32.6	7.1	-7.2	32.6	Peak [Scan]	H	98	361	47.5	-14.9	Pass	

Legend: DIG = Digital Device Emission; TX = Transmitter Emission; FUND = Fundamental Frequency
 NRB = Non-Restricted Band, Limit is 20 dB below Fundamental; RB = Restricted Band

This test report may be reproduced in full only. The document may only be updated by MiCOM Labs personnel. Any changes will be noted in the Document History section of the report.



Title: Aruba Networks APIN0214, APIN0215
To: FCC 47 CFR Part 15.407 & IC RSS-210
Serial #: ARUB179-U8 Rev B
Issue Date: 2nd September 2014
Page: 123 of 330

APIN0214

Test Freq.	2437 MHz	Engineer	JMH
Variant	Digital Emissions	Temp (°C)	24
Freq. Range	30 MHz - 1000 MHz	Rel. Hum.(%)	32
Power Setting	19	Press. (mBars)	997
Antenna	AP ANT 13B	Duty Cycle (%)	99
Test Notes 1	AP214 P302; EUT=Vertical; S/N : CK0000634; MAC: 24 DE C6 CF 5A BA;		
Test Notes 2	POE:PowerDSine 9001GR 55VDC / 350mA;		



Formally measured emission peaks

Frequency MHz	Raw dBuV	Cable Loss	AF dB	Level dBuV/m	Measurement Type	Pol	Hgt cm	Azt Deg	Limit dBuV/m	Margin dB	Pass /Fail	Comments
50.130	54.1	3.7	-22.8	35.0	Quasi Max	V	109	95	40.5	-5.5	Pass	
106.904	52.4	4.1	-19.1	37.4	Quasi Max	V	106	112	40.5	-3.1	Pass	
158.567	49.7	4.4	-18.4	35.8	Quasi Max	V	99	108	40.5	-4.7	Pass	
38.040	46.4	3.6	-15.8	34.3	Peak [Scan]	V	98	0	40.5	-6.3	Pass	
98.055	51.4	4.1	-21.4	34.1	Peak [Scan]	V	98	0	40.5	-6.4	Pass	
300.280	49.8	5.1	-17.0	37.9	Peak [Scan]	H	98	0	47.5	-9.6	Pass	

Legend: DIG = Digital Device Emission; TX = Transmitter Emission; FUND = Fundamental Frequency
 NRB = Non-Restricted Band, Limit is 20 dB below Fundamental; RB = Restricted Band

This test report may be reproduced in full only. The document may only be updated by MiCOM Labs personnel. Any changes will be noted in the Document History section of the report.



Title: Aruba Networks APIN0214, APIN0215
To: FCC 47 CFR Part 15.407 & IC RSS-210
Serial #: ARUB179-U8 Rev B
Issue Date: 2nd September 2014
Page: 124 of 330

APIN0215

Test Freq.	2437	Engineer	JMH
Variant	Digital Emissions	Temp (°C)	24
Freq. Range	30 MHz - 1000 MHz	Rel. Hum.(%)	31
Power Setting	16	Press. (mBars)	999
Antenna	Integral		
Test Notes 1	Sunny PS (model# SYS1357-1812) Powered, AP215 SN# CK0000823		
Test Notes 2	Ethernet hub mounted underneath turntable and console cable removed		

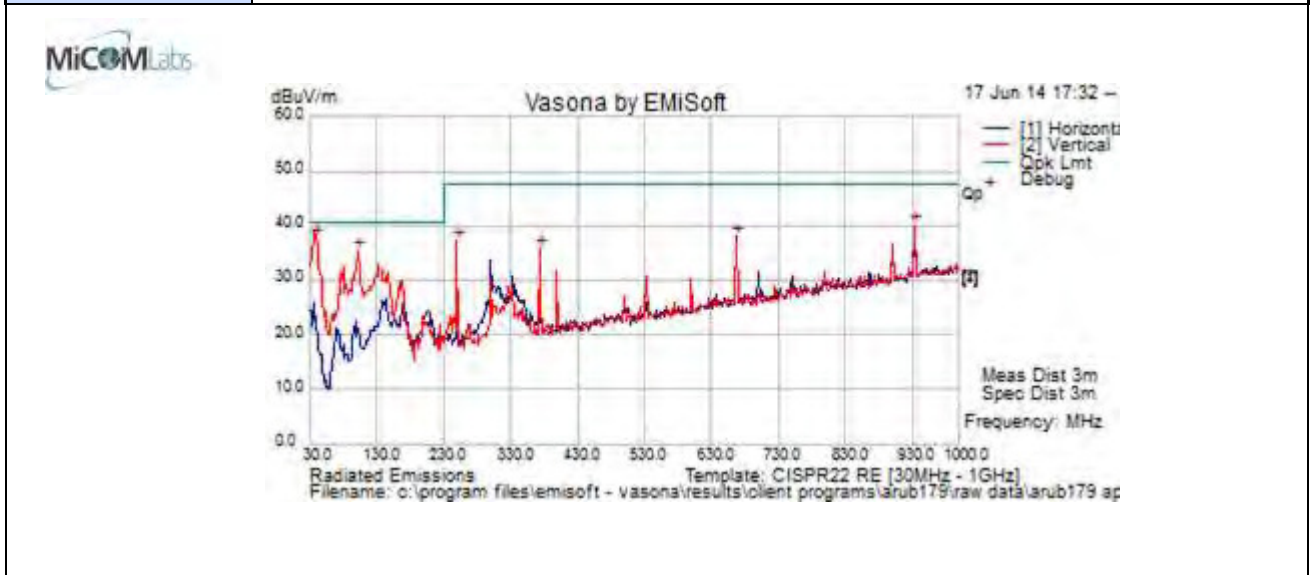

Formally measured emission peaks

Frequency MHz	Raw dBuV	Cable Loss	AF dB	Level dBuV/m	Measurement Type	Pol	Hgt cm	Azt Deg	Limit dBuV/m	Margin dB	Pass /Fail	Comments
38.968	50.1	3.6	-16.3	37.4	Quasi Max	V	131	179	40.5	-3.1	Pass	
101.899	51.3	4.1	-20.3	35.2	Quasi Max	V	98	346	40.5	-5.3	Pass	
933.896	39.4	7.2	-6.6	40.0	Peak [Scan]	V	98	361	47.5	-7.5	Pass	
667.592	41.8	6.4	-10.2	38.0	Peak [Scan]	H	98	361	47.5	-9.5	Pass	
249.674	51.1	4.9	-18.8	37.2	Peak [Scan]	V	98	361	47.5	-10.3	Pass	
374.121	45.5	5.4	-15.3	35.6	Peak [Scan]	V	98	361	47.5	-12.0	Pass	

Legend: DIG = Digital Device Emission; TX = Transmitter Emission; FUND = Fundamental Frequency
 NRB = Non-Restricted Band, Limit is 20 dB below Fundamental; RB = Restricted Band

This test report may be reproduced in full only. The document may only be updated by MiCOM Labs personnel. Any changes will be noted in the Document History section of the report.



Specification

Limits

§15.205 (a) Except as shown in paragraph (d) of 15.205 (a), only spurious emissions are permitted in any of the frequency bands listed.

§15.205 (a) Except as shown in paragraphs (d) and (e) of this section, the field strength of emissions appearing within these frequency bands shall not exceed the limits shown in Section §15.209. At frequencies equal to or less than 1000 MHz, compliance with the limits in Section 15.209 shall be demonstrated using measurement instrumentation employing a CISPR quasi-peak detector. Above 1000 MHz, compliance with the emission limits in Section 15.209 shall be demonstrated based on the average value of the measured emissions. The provisions in Section 15.35 apply to these measurements.

§15.209 (a) Except as provided elsewhere in this subpart, the emissions from an intentional radiator shall not exceed the field strength levels specified in the following table.

§15.209 (a) and RSS-Gen §2.2 Limit Matrix

Frequency(MHz)	Field Strength (µV/m)	Field Strength (dBµV/m)	Measurement Distance (meters)
30-88	100	40.0	3
88-216	150	43.5	3
216-960	200	46.0	3
Above 960	500	54.0	3

Laboratory Measurement Uncertainty for Radiated Emissions

Measurement uncertainty	+5.6/ -4.5 dB
-------------------------	---------------

Traceability

Method
Measurements were made per work instruction WI-03 'Measurement of Radiated Emissions'

6.1.3. AC Wireline Conducted Emissions (150 kHz – 30 MHz)

FCC, Part 15 Subpart C §15.207
Industry Canada RSS-Gen §7.2.2

Test Procedure

The EUT is configured in accordance with ANSI C63.4. The conducted emissions are measured in a shielded room with a spectrum analyzer in peak hold in the first instance. Emissions closest to the limit are measured in the quasi-peak mode (QP) with the tuned receiver using a bandwidth of 9 kHz. The emissions are maximized further by cable manipulation. The highest emissions relative to the limit are listed.

Measurement Results for AC Wireline Conducted Emissions (150 kHz – 30 MHz)

Ambient conditions.

Temperature: 17 to 23 °C Relative humidity: 31 to 57 % Pressure: 999 to 1012 mbar

Test Measurement Set up

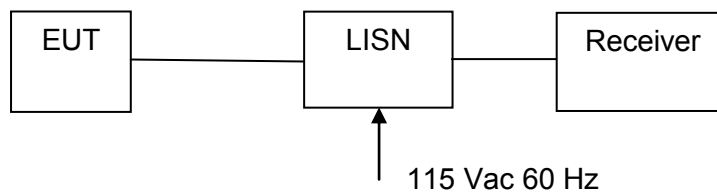

Measurement set up for AC Wireline Conducted Emissions Test

Measurement Results for AC Wireline Conducted Emissions (150 kHz – 30 MHz)

Ambient conditions.

Temperature: 17 to 23 °C Relative humidity: 31 to 57 % Pressure: 999 to 1012 mbar



Title: Aruba Networks APIN0214, APIN0215
To: FCC 47 CFR Part 15.407 & IC RSS-210
Serial #: ARUB179-U8 Rev B
Issue Date: 2nd September 2014
Page: 127 of 330

ac Wireline Emissions

Test Freq.	N/A	Engineer	JMH
Variant	AC Line Emissions	Temp (°C)	20
Freq. Range	0.150 MHz - 30 MHz	Rel. Hum.(%)	35
Power Setting	NA	Press. (mBars)	999
Antenna	N/A		
Test Notes 1	POE Powered By 650 Controller AP Model# AP-214, SN# CK0000562		
Test Notes 2	110VAC 60 Hz		

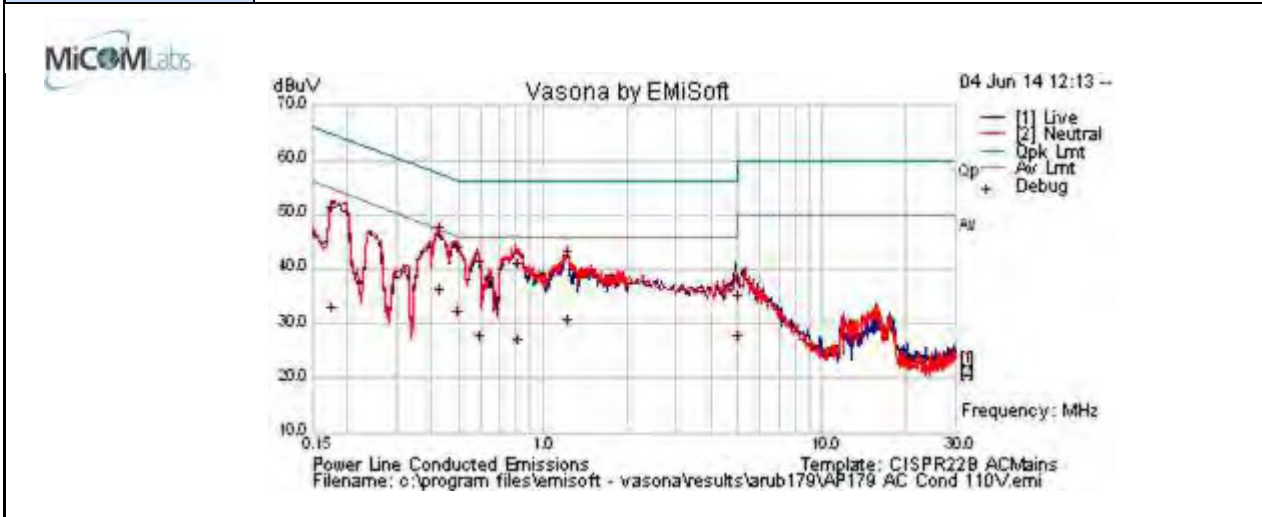

Formally measured emission peaks

Frequency MHz	Raw dBuV	Cable Loss	Factors dB	Level dBuV	Measurement Type	Line	Limit dBuV	Margin dB	Pass /Fail	Comments
0.175	21.4	9.9	0.1	31.4	Average	Live	54.7	-23.3	Pass	
0.175	39.6	9.9	0.1	49.6	Quasi Peak	Live	64.7	-15.2	Pass	
0.421	36.3	9.9	0.1	46.3	Quasi Peak	Neutral	57.4	-11.2	Pass	
0.421	24.8	9.9	0.1	34.8	Average	Neutral	47.4	-12.7	Pass	
0.488	20.7	9.9	0.1	30.7	Average	Neutral	46.2	-15.5	Pass	
0.488	32.4	9.9	0.1	42.4	Quasi Peak	Neutral	56.2	-13.8	Pass	
0.586	29.8	9.9	0.1	39.8	Quasi Peak	Live	56.0	-16.2	Pass	
0.586	16.4	9.9	0.1	26.4	Average	Live	46.0	-19.6	Pass	
0.803	29.5	10.0	0.1	39.5	Quasi Peak	Neutral	56.0	-16.5	Pass	
0.803	15.6	10.0	0.1	25.6	Average	Neutral	46.0	-20.4	Pass	
1.225	31.5	10.0	0.1	41.5	Quasi Peak	Neutral	56.0	-14.5	Pass	
1.225	19.0	10.0	0.1	29.1	Average	Neutral	46.0	-16.9	Pass	
4.954	23.2	10.2	0.2	33.5	Quasi Peak	Live	56.0	-22.5	Pass	
4.954	15.7	10.2	0.2	26.1	Average	Live	46.0	-19.9	Pass	

Legend: DIG = Digital Device Emission; TX = Transmitter Emission; FUND = Fundamental Frequency
 NRB = Non-Restricted Band, Limit is 20 dB below Fundamental; RB = Restricted Band

This test report may be reproduced in full only. The document may only be updated by MiCOM Labs personnel. Any changes will be noted in the Document History section of the report.



Specification

Limit

§15.207 (a) Except as shown in paragraphs (b) and (c) of this section, for an intentional radiator that is designed to be connected to the public utility (AC) power line, the radio frequency voltage that is conducted back onto the AC power line on any frequency or frequencies within the band 150 kHz to 30 MHz shall not exceed the limits in the following table, as measured using a 50 $\mu\Omega$ line impedance stabilization network (LISN), see §15.207 (a) matrix below. Compliance with the provisions of this paragraph shall be based on the measurement of the radio frequency voltage between each power line and ground at the power terminal.

RSS-Gen §7.2.2

The radio frequency voltage that is conducted back into the AC power lines in the frequency range of 0.15 MHz to 30 MHz shall not exceed the limits shown in the table below. The tighter limit applies at the frequency range boundaries.

§15.207 (a) and RSS-Gen §7.2.2 Limit Matrix

The lower limit applies at the boundary between frequency ranges

Frequency of Emission (MHz)	Conducted Limit (dB μ V)	
	Quasi-peak	Average
0.15-0.5	66 to 56*	56 to 46*
0.5-5	56	46
5-30	60	50

* Decreases with the logarithm of the frequency

Laboratory Measurement Uncertainty for Conducted Emissions

Measurement uncertainty	± 2.64 dB
-------------------------	---------------

Traceability

Method
Measurements were made per work instruction WI-EMC-01 'Measurement of Conducted Emissions'



6.1.4. Dynamic Frequency Selection (DFS)

FCC, Part 15 Subpart C §15.407(h)
FCC 06-96 Memorandum Opinion and Order
Industry Canada RSS-210 A9.4

6.1.4.1. Interference Threshold values, Master or Client incorporating In-Service Monitoring

Maximum Transmit Power	Value (see note)
≥ 200 milliwatt	-64 dBm
< 200 milliwatt	-62 dBm

Note 1: This is the level at the input of the receiver assuming a 0 dBi receive antenna

6.1.4.2. DFS Response requirement values

Parameter	Value
<i>Non-occupancy period</i>	Minimum 30 minutes
<i>Channel Availability Check Time</i>	60 seconds
<i>Channel Move Time</i>	10 seconds See Note 1.
<i>Channel Closing Transmission Time</i>	200 milliseconds + an aggregate of 60 milliseconds over remaining 10 second period. See Notes 1 and 2.
<i>U-NII Detection Bandwidth</i>	Minimum 80% of the 99% power bandwidth See Note 3.

Note 1: The instant that the *Channel Move Time* and the *Channel Closing Transmission Time* begins is as follows:

- For the Short pulse radar Test Signals this instant is the end of the *Burst*.
- For the Frequency Hopping radar Test Signal, this instant is the end of the last radar *Burst* generated.
- For the Long Pulse radar Test Signal this instant is the end of the 12 second period defining the radar transmission.

Note 2: The *Channel Closing Transmission Time* is comprised of 200 milliseconds starting at the beginning of the *Channel Move Time* plus any additional intermittent control signals required to facilitate *Channel* changes (an aggregate of 60 milliseconds) during the remainder of the 10 second period. The aggregate duration of control signals will not count quiet periods in between transmissions.

Note 3: During the *U-NII Detection Bandwidth* detection test, radar type 1 is used and for each frequency step the minimum percentage of detection is 90%. Measurements are performed with no data traffic.



6.1.4.3. Radar Test Waveforms

This section provides the parameters for required test waveforms, minimum percentage of successful detections, and the minimum number of trials that must be used for determining DFS conformance. Step intervals of 0.1 microsecond for Pulse Width, 1 microsecond for PRI, 1 MHz for chirp width and 1 for the number of pulses will be utilized for the random determination of specific test waveforms.

Short Pulse Radar Test Waveforms

Radar Type	Pulse Width (μ sec)	PRI (μ sec)	Number of Pulses	Minimum Percentage of Successful Detection	Minimum Trials
1	1	1428	18	60%	30
2	1-5	150-230	23-29	60%	30
3	6-10	200-500	16-18	60%	30
4	11-20	200-500	12-16	60%	30
Aggregate (Radar Types 1-4)				80%	120

A minimum of 30 unique waveforms are required for each of the short pulse radar types 2 through 4. For short pulse radar type 1, the same waveform is used a minimum of 30 times. If more than 30 waveforms are used for short pulse radar types 2 through 4, then each additional waveform must also be unique and not repeated from the previous waveforms. The aggregate is the average of the percentage of successful detections of short pulse radar types 1-4.

Long Pulse Radar Test Waveform

Radar Type	Pulse Width (μ sec)	Chirp Width (MHz)	PRI (μ sec)	Number of Pulses per Burst	Number of Bursts	Minimum Percentage of Successful Detection	Minimum Trials
5	50-100	5-20	1000-2000	1-3	8-20	80%	30

The parameters for this waveform are randomly chosen. Thirty unique waveforms are required for the Long Pulse radar test signal. If more than 30 waveforms are used for the Long Pulse radar test signal, then each additional waveform must also be unique and not repeated from the previous waveforms.



Title: Aruba Networks APIN0214, APIN0215
To: FCC 47 CFR Part 15.407 & IC RSS-210
Serial #: ARUB179-U8 Rev B
Issue Date: 2nd September 2014
Page: 131 of 330

Each waveform is defined as follows:

- 1) The transmission period for the Long Pulse Radar test signal is 12 seconds.
- 2) There are a total of 8 to 20 *Bursts* in the 12 second period, with the number of *Bursts* being randomly chosen. This number is *Burst Count*.
- 3) Each *Burst* consists of 1 to 3 pulses, with the number of pulses being randomly chosen. Each *Burst* within the 12 second sequence may have a different number of pulses.
- 4) The pulse width is between 50 and 100 microseconds, with the pulse width being randomly chosen. Each pulse within a *Burst* will have the same pulse width. Pulses in different *Bursts* may have different pulse widths.
- 5) Each pulse has a linear FM chirp between 5 and 20 MHz, with the chirp width being randomly chosen. Each pulse within a *Burst* will have the same chirp width. Pulses in different *Bursts* may have different chirp widths. The chirp is centered on the pulse. For example, with a radar frequency of 5300 MHz and a 20 MHz chirped signal, the chirp starts at 5290 MHz and ends at 5310 MHz.
- 6) If more than one pulse is present in a *Burst*, the time between the pulses will be between 1000 and 2000 microseconds, with the time being randomly chosen. If three pulses are present in a *Burst*, the time between the first and second pulses is chosen independently of the time between the second and third pulses.
- 7) The 12 second transmission period is divided into even intervals. The number of intervals is equal to *Burst_Count*. Each interval is of length $(12,000,000 / \textit{Burst_Count})$ microseconds. Each interval contains one *Burst*. The start time for the *Burst*, relative to the beginning of the interval, is between 1 and $[(12,000,000 / \textit{Burst_Count}) - (\textit{Total Burst Length}) + (\textit{One Random PRI Interval})]$ microseconds, with the start time being randomly chosen. The step interval for the start time is 1 microsecond. The start time for each *Burst* is chosen independently.

This test report may be reproduced in full only. The document may only be updated by MiCOM Labs personnel. Any changes will be noted in the Document History section of the report.

A representative example of a Long Pulse radar test waveform:

- 1) The total test signal length is 12 seconds.
- 2) 8 *Bursts* are randomly generated for the *Burst_Count*.
- 3) *Burst 1* has 2 randomly generated pulses.
- 4) The pulse width (for both pulses) is randomly selected to be 75 microseconds.
- 5) The PRI is randomly selected to be at 1213 microseconds.
- 6) *Bursts 2* through 8 are generated using steps 3 – 5.
- 7) Each *Burst* is contained in even intervals of 1,500,000 microseconds. The starting location for Pulse 1, *Burst 1* is randomly generated (1 to 1,500,000 minus the total *Burst 1* length + 1 random PRI interval) at the 325,001 microsecond step. *Bursts 2* through 8 randomly fall in successive 1,500,000 microsecond intervals (i.e. *Burst 2* falls in the 1,500,001 – 3,000,000 microsecond range).

Graphical representation of the Long Pulse radar Test Waveform.

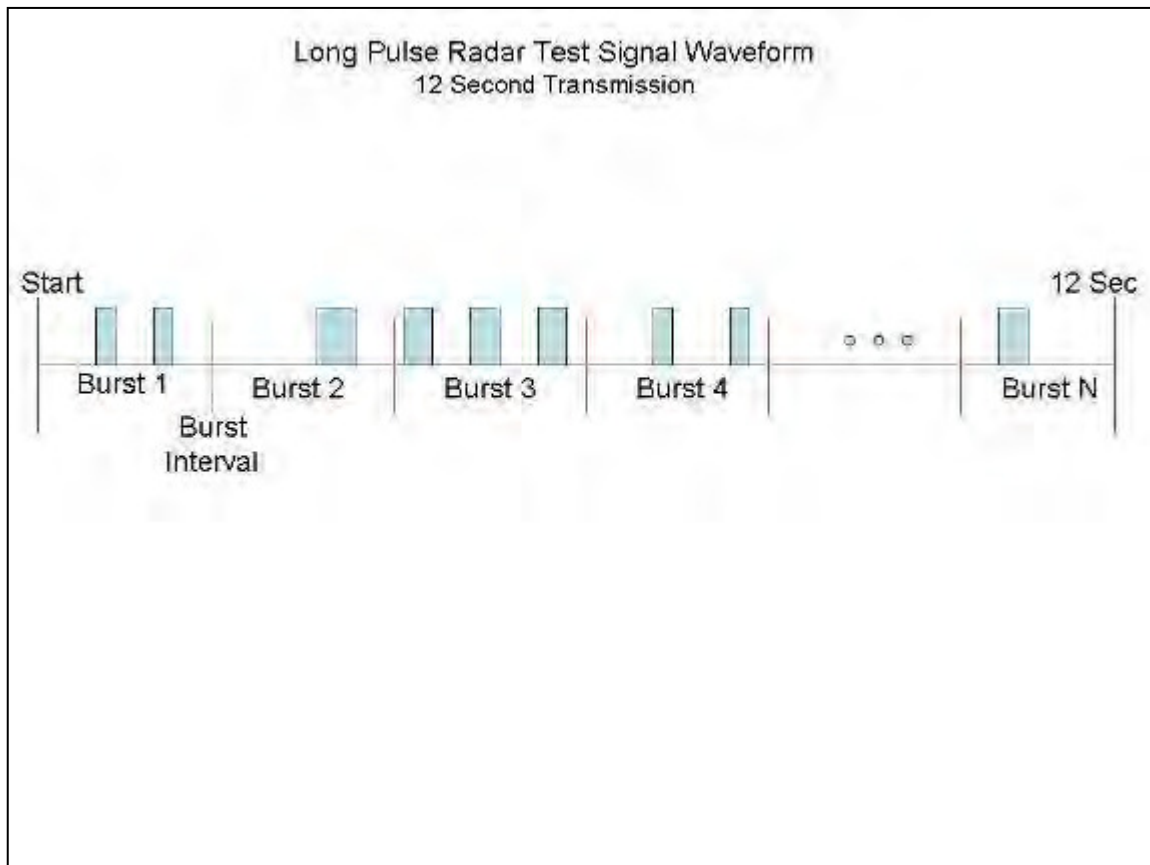

6.1.4.4. Frequency Hopping Radar Test Waveform

Frequency Hopping Radar Test Waveform

Radar Type	Pulse Width (μsec)	PRI (μsec)	Pulses per Hop	Hopping Rate (kHz)	Hopping Sequence Length (msec)	Minimum Percentage of Successful Detection	Minimum Trials
6	1	333	9	.333	300	70%	30

For the Frequency Hopping Radar Type, the same *Burst* parameters are used for each waveform. The hopping sequence is different for each waveform and a 100-length segment is selected from the hopping sequence defined by the following algorithm:

6.1.4.5. Radar Waveform Calibration

The following equipment setup was used to calibrate the conducted Radar Waveform. A spectrum analyzer was used to establish the test signal level for each radar type. During this process there were no transmissions by either the Master or Client Device. The spectrum analyzer was switched to the zero span (Time Domain) mode at the frequency of the Radar Waveform generator. Peak detection was utilized. The spectrum analyzer resolution bandwidth (RBW) and video bandwidth (VBW) were set to 3 MHz.

The signal generator amplitude was set so that the power level measured at the spectrum analyzer was -61dBm (Ref Section 5.1). The 30dB amplifier gain was entered as an amplitude offset on the spectrum analyzer.

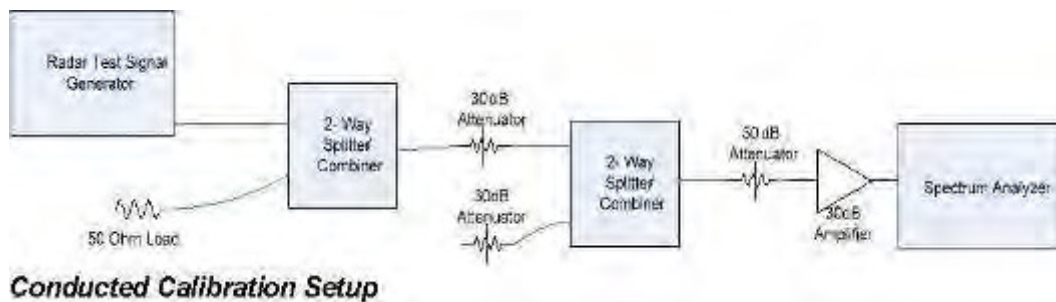



6.1.4.6. Weather Radar Band Edge Plots

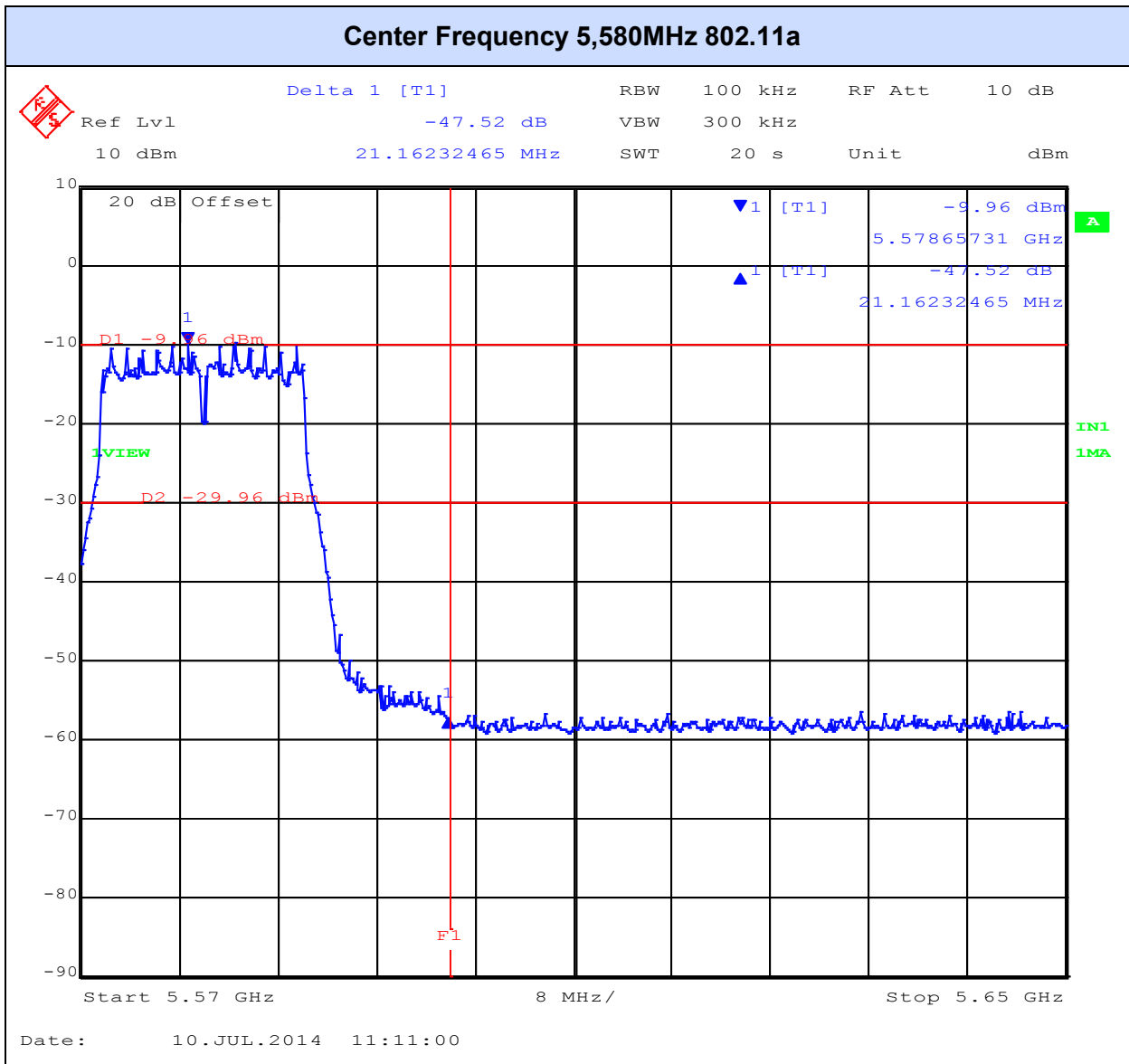

This test report may be reproduced in full only. The document may only be updated by MiCOM Labs personnel. Any changes will be noted in the Document History section of the report.

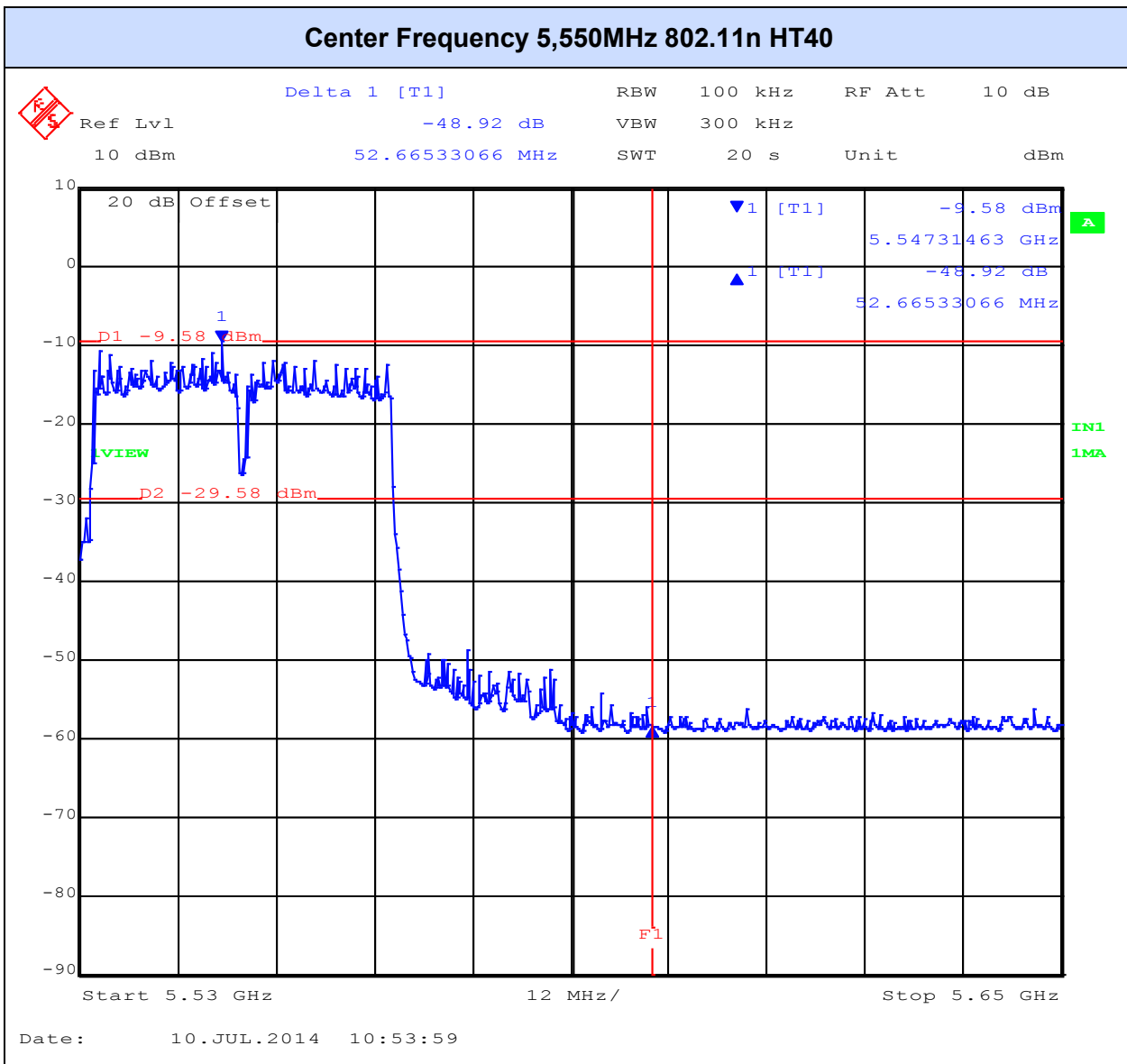

This test report may be reproduced in full only. The document may only be updated by MiCOM Labs personnel. Any changes will be noted in the Document History section of the report.

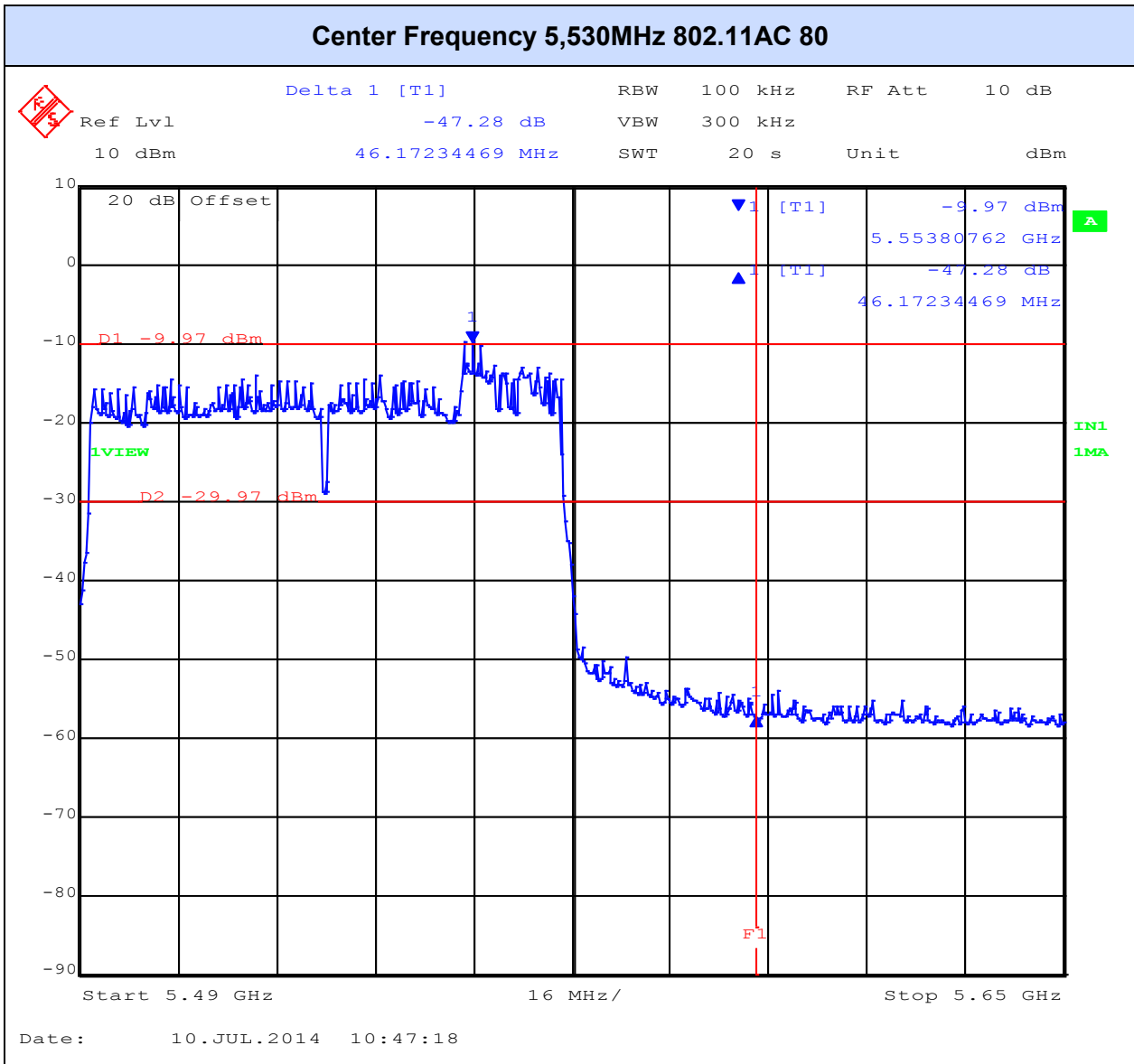

This test report may be reproduced in full only. The document may only be updated by MiCOM Labs personnel. Any changes will be noted in the Document History section of the report.



Title: Aruba Networks APIN0214, APIN0215
To: FCC 47 CFR Part 15.407 & IC RSS-210
Serial #: ARUB179-U8 Rev B
Issue Date: 2nd September 2014
Page: 138 of 330

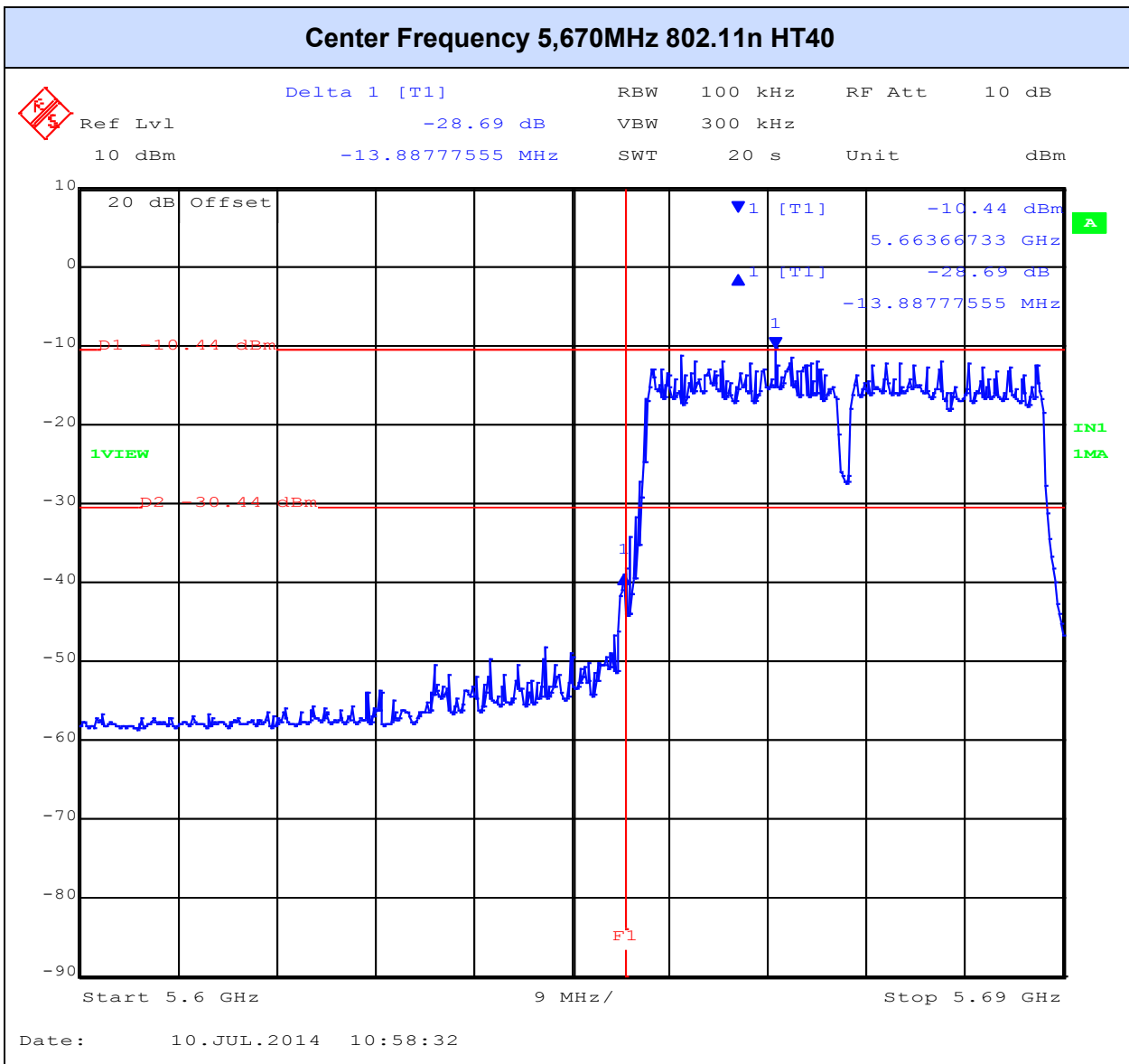

This test report may be reproduced in full only. The document may only be updated by MiCOM Labs personnel. Any changes will be noted in the Document History section of the report.



Title: Aruba Networks APIN0214, APIN0215
To: FCC 47 CFR Part 15.407 & IC RSS-210
Serial #: ARUB179-U8 Rev B
Issue Date: 2nd September 2014
Page: 139 of 330

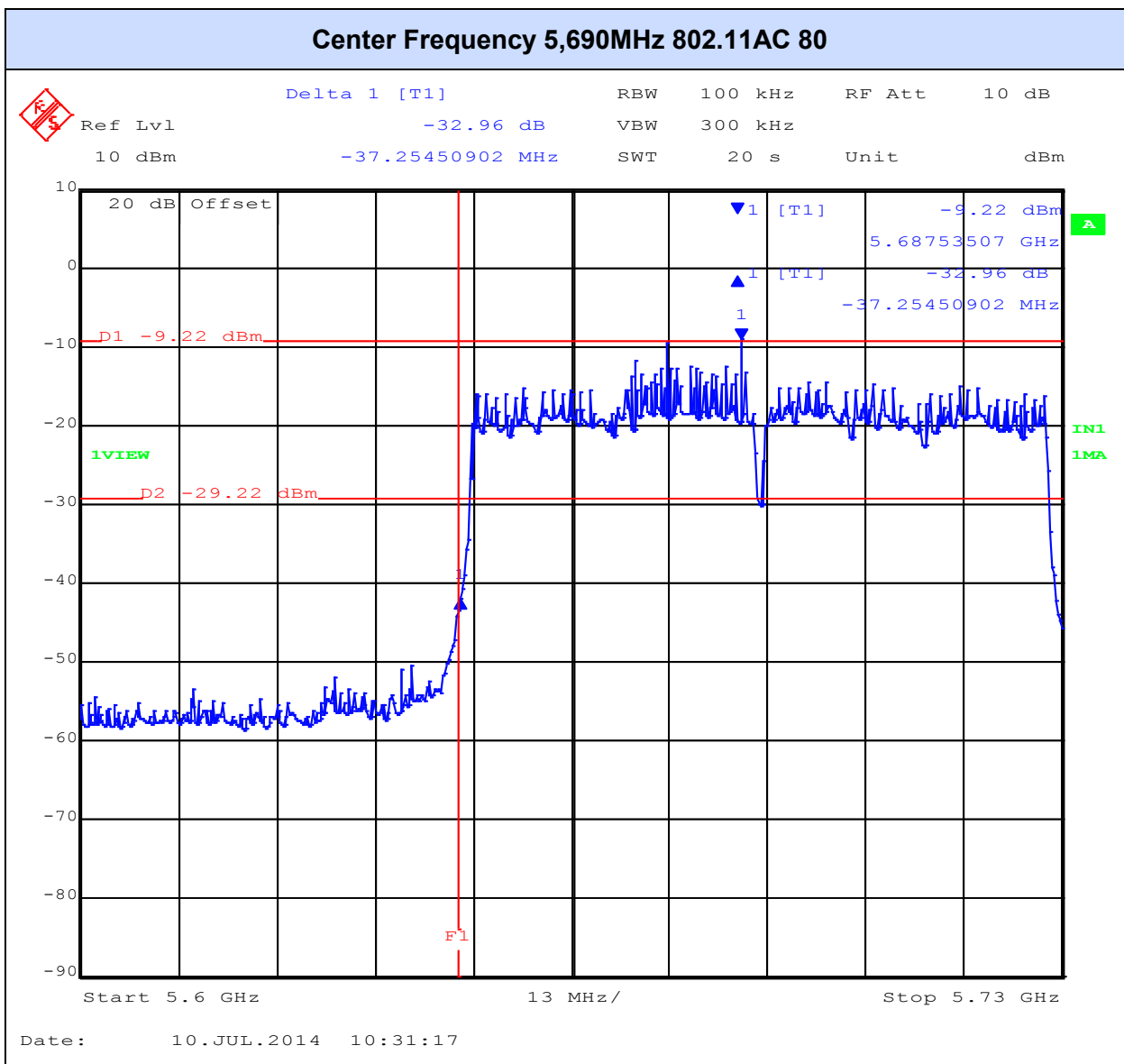

This test report may be reproduced in full only. The document may only be updated by MiCOM Labs personnel. Any changes will be noted in the Document History section of the report.



The EUT is a Master Device with radar detection.

Applicability of DFS Requirements Prior to Use of a Channel
(Ref Table 1 of FCC 06-96)

Requirement	Operational Mode		
	Master	Client Without Radar Detection	Client With Radar Detection
<i>Non-Occupancy Period</i>	Yes	Not required	Yes
<i>DFS Detection Threshold</i>	Yes	Not required	Yes
<i>Channel Availability Check Time</i>	Yes	Not required	Not required
<i>Uniform Spreading</i>	Yes	Not required	Not required
<i>U-NII Detection Bandwidth</i>	Yes	Not required	Yes

Applicability of DFS requirements during normal operation
(Ref Table 2 of FCC 06-96)

Requirement	Operational Mode		
	Master	Client Without Radar Detection	Client With Radar Detection
<i>DFS Detection Threshold</i>	Yes	Not required	Yes
<i>Channel Closing Transmission Time</i>	Yes	Yes	Yes
<i>Channel Move Time</i>	Yes	Yes	Yes
<i>U-NII Detection Bandwidth</i>	Yes	Not required	Yes

This test report may be reproduced in full only. The document may only be updated by MiCOM Labs personnel. Any changes will be noted in the Document History section of the report.



Title: Aruba Networks APIN0214, APIN0215
To: FCC 47 CFR Part 15.407 & IC RSS-210
Serial #: ARUB179-U8 Rev B
Issue Date: 2nd September 2014
Page: 141 of 330

For the frequency band 5,470 – 5,725 MHz, the Master device provides, on aggregate, uniform loading of the spectrum across all devices by selecting an operating channel among the available channels using a random algorithm.

Declared minimum antenna gain 2 dBi. ;

Radar receive signal level = -64 dBm + minimum antenna gain + 1 dB

$$= -64 + 2$$

Radar receive signal level = -61 dBm

Measurement Results - Dynamic Frequency Selection (DFS)

Ambient conditions.

Temperature: 17 to 23 °C Relative humidity: 31 to 57% Pressure: 999 to 1012 mbar

Radio parameters.

Test methodology: Conducted

Device Type: Master

Transmit Power: Maximum

This test report may be reproduced in full only. The document may only be updated by MiCOM Labs personnel. Any changes will be noted in the Document History section of the report.



Title: Aruba Networks APIN0214, APIN0215
To: FCC 47 CFR Part 15.407 & IC RSS-210
Serial #: ARUB179-U8 Rev B
Issue Date: 2nd September 2014
Page: 142 of 330

Operational Details - Dynamic Frequency Selection (DFS)

Operational Modes: 802.11a, 802.11n HT40, and 802.11ac 80

Data Rates: 6mpbs 802.11a/ 0MCS 802.11n/ac

**Note* video pixilation was observed during the video stream at these rates, however they were very minor and only occurred a few times but the video maintained 30 frames per second.*

Software Revisions

Original Image:

Software Version : ArubaOS 6.4.1.0 (Digitally Signed - Production Build)
Build number : 43845
Label : 43845

New Image Version:

Software Version : ArubaOS 6.4.2.0-url (Digitally Signed - Production Build)
Build number : 44448
Label : 44448

This version was used to spot check center frequency. The EUT would not recognize any radar signature at the center frequency i.e 5500 MHz 5510 MHz and 5530 MHz using the original image

Video Streaming Method - Dynamic Frequency Selection (DFS)

Using the VideoLan player a video stream was setup on the master laptop with the destination being the client laptop. The video profile chosen for the video stream is "MPEG-2 + MPGA (TS)". On the client laptop the VideoLan player was setup to listen to an incoming video stream from the master device.

The requisite MPEG video file ("TestFile.mpg" available on the NTIA website at the following link <http://ntiacsd.ntia.doc.gov/dfs/>) is used during this video stream.

This test report may be reproduced in full only. The document may only be updated by MiCOM Labs personnel. Any changes will be noted in the Document History section of the report.



Title: Aruba Networks APIN0214, APIN0215
To: FCC 47 CFR Part 15.407 & IC RSS-210
Serial #: ARUB179-U8 Rev B
Issue Date: 2nd September 2014
Page: 143 of 330

6.2. Dynamic Frequency Selection (DFS) Test Results

6.2.1. UNII Detection Bandwidth:

All UNII channels for this device have identical channel bandwidths and DFS testing was completed on channel 5,500 MHz (802.11a), 5510MHz (HT40), and 5530 (AC80).

The generating equipment is configured as shown in the Conducted Test Setup above. A single Burst of the short pulse radar Type 1 through 6 was produced at 5,500 MHz (802.11a) , 5,510 MHz (802.11n HT40), and 5,530 MHz (802.11ac 80 at a level of -62 dBm (Ref Section 5.1). The EUT is set up as a standalone device (no associated Client and no traffic).

A single radar Burst is generated for a minimum of 10 trials, and the response of the EUT is noted. The EUT must detect the Radar Waveform 90% or more of the time.

The radar frequency is increased in 1 MHz steps, repeating the above test sequence, until the detection rate falls below 90%. The highest frequency at which detection is greater than or equal to 90% is denoted as F_H .

The radar frequency is decreased in 1 MHz steps, repeating the above test sequence, until the detection rate falls below 90%. The lowest frequency at which detection is greater than or equal to 90% is denoted as F_L .

The U-NII Detection Bandwidth is calculated as follows:

$$\text{U-NII Detection Bandwidth} = F_H - F_L$$

The U-NII Detection Bandwidth must be at least 80% of the EUT transmitter 99% power
Table of results are continued on the next page.

This test report may be reproduced in full only. The document may only be updated by MiCOM Labs personnel. Any changes will be noted in the Document History section of the report.



Title: Aruba Networks APIN0214, APIN0215
To: FCC 47 CFR Part 15.407 & IC RSS-210
Serial #: ARUB179-U8 Rev B
Issue Date: 2nd September 2014
Page: 144 of 330

EUT Frequency= 5,500 MHz 802.11a (Detection = √, No Detection = 0)											
Radar Frequency (MHz)	1	2	3	4	5	6	7	8	9	10	Detection Rate (%)
-20											%
-19											%
-18											%
-17											%
-16											%
-15											%
-14											%
-13											%
-12											%
-11											%
-10	o	o									<90%
-9	v	v	v	v	v	v	v	v	v	v	100%
-8	v	v	v	v	v	v	v	v	v	v	100%
-7	v	v	v	v	v	v	v	v	v	v	100%
-6	v	v	v	v	v	v	v	v	v	v	100%
-5	v	v	v	v	v	v	v	v	v	v	100%
-4	v	v	v	v	v	v	v	v	v	v	100%
-3	v	v	v	v	v	v	v	v	v	v	100%
-2	v	v	v	v	v	v	v	v	v	v	100%
-1	v	v	v	v	v	v	v	v	v	v	100%
F ₀	v	v	v	v	v	v	v	v	v	v	100%
+1	v	v	v	v	v	v	v	v	v	v	100%
+2	v	v	v	v	v	v	v	v	v	v	100%
+3	v	v	v	v	v	v	v	v	v	v	100%
+4	v	v	v	v	v	v	v	v	v	v	100%
+5	v	v	v	v	v	v	v	v	v	v	100%
+6	v	v	v	v	v	v	v	v	v	v	100%
+7	v	v	v	v	v	v	v	v	v	v	100%
+8	o	o									<90%
+9	o	o									<90%
+10											%
+11											%
+12											%
+13											%
+14											%
+15											%
+16											%
+17											%
Detection Bandwidth = F _H -F _L = 5507-5491 = 16 MHz											
EUT 99% Bandwidth = 16.63 MHz (ref. bandwidth channel 5500 MHz)											
16.63 MHz *80% = 13.304 MHz											

For each frequency step the minimum percentage detection is 90%

This test report may be reproduced in full only. The document may only be updated by MiCOM Labs personnel. Any changes will be noted in the Document History section of the report.



Title: Aruba Networks APIN0214, APIN0215
To: FCC 47 CFR Part 15.407 & IC RSS-210
Serial #: ARUB179-U8 Rev B
Issue Date: 2nd September 2014
Page: 145 of 330

EUT Frequency= 5,510 MHz 802.11n HT40 (Detection = √, No Detection = 0)											
Radar Frequency (MHz)	1	2	3	4	5	6	7	8	9	10	Detection Rate (%)
-21											%
-20	o	o									<90%
-19	v	v	v	v	v	v	v	v	v	v	100%
-18	v	v	v	v	v	v	v	v	v	v	100%
-17	v	v	v	v	v	v	v	v	v	v	100%
-16	v	v	v	v	v	v	v	v	v	v	100%
-15	v	v	v	v	v	v	v	v	v	v	100%
-14	v	v	v	v	v	v	v	v	v	v	100%
-13	v	v	v	v	v	v	v	v	v	v	100%
-12	v	v	v	v	v	v	v	v	v	v	100%
-11	v	v	v	v	v	v	v	v	v	v	100%
-10	v	v	v	v	v	v	v	v	v	v	100%
-9	v	v	v	v	v	v	v	v	v	v	100%
-8	v	v	v	v	v	v	v	v	v	v	100%
-7	v	v	v	v	v	v	v	v	v	v	100%
-6	v	v	v	v	v	v	v	v	v	v	100%
-5	v	v	v	v	v	v	v	v	v	v	100%
-4	v	v	v	v	v	v	v	v	v	v	100%
-3	v	v	v	v	v	v	v	v	v	v	100%
-2	v	v	v	v	v	v	v	v	v	v	100%
-1	v	v	v	v	v	v	v	v	v	v	100%
F ₀	v	v	v	v	v	v	v	v	v	v	100%

This test report may be reproduced in full only. The document may only be updated by MiCOM Labs personnel. Any changes will be noted in the Document History section of the report.



Title: Aruba Networks APIN0214, APIN0215
To: FCC 47 CFR Part 15.407 & IC RSS-210
Serial #: ARUB179-U8 Rev B
Issue Date: 2nd September 2014
Page: 146 of 330

EUT Frequency= 5,510 MHz 802.11n HT40 (Detection = √, No Detection = 0)											
Radar Frequency (MHz)	1	2	3	4	5	6	7	8	9	10	Detection Rate (%)
F ₀	v	v	v	v	v	v	v	v	v	v	100%
+1	v	v	v	v	v	v	v	v	v	v	100%
+2	v	v	v	v	v	v	v	v	v	v	100%
+3	v	v	v	v	v	v	v	v	v	v	100%
+4	v	v	v	v	v	v	v	v	v	v	100%
+5	v	v	v	v	v	v	v	v	v	v	100%
+6	v	v	v	v	v	v	v	v	v	v	100%
+7	v	v	v	v	v	v	v	v	v	v	100%
+8	v	v	v	v	v	v	v	v	v	v	100%
+9	v	v	v	v	v	v	v	v	v	v	100%
+10	v	v	v	v	v	v	v	v	v	v	100%
+11	v	v	v	v	v	v	v	v	v	v	100%
+12	v	v	v	v	v	v	v	v	v	v	100%
+13	v	v	v	v	v	v	v	v	v	v	100%
+14	v	v	v	v	v	v	v	v	v	v	100%
+15	v	v	v	v	v	v	v	v	v	v	100%
+16	v	v	v	v	v	v	v	v	v	v	100%
+17	v	v	v	v	v	v	v	v	v	v	100%
+18	v	v	v	v	v	v	v	v	v	v	100%
+19	o	o									<90%
+20											<90%
+21											<90%
Detection Bandwidth = F _H -F _L = 5528-5491 = 37 MHz											
EUT 99% Bandwidth = 36.27 MHz (ref. bandwidth channel 5510 MHz)											
36.27 MHz *80% = 29.016 MHz											

For each frequency step the minimum percentage detection is 90%

This test report may be reproduced in full only. The document may only be updated by MiCOM Labs personnel. Any changes will be noted in the Document History section of the report.



Title: Aruba Networks APIN0214, APIN0215
To: FCC 47 CFR Part 15.407 & IC RSS-210
Serial #: ARUB179-U8 Rev B
Issue Date: 2nd September 2014
Page: 147 of 330

Center Frequency= 5,530 MHz , 802.11ac ,HT80 (Detection = √, No Detection = 0)											
Radar Frequency (MHz)	1	2	3	4	5	6	7	8	9	10	Detection Rate (%)
-41											%
-40											%
-39	o	o									<90%
-38	v	v	v	v	v	v	v	v	v	v	100%
-37	v	v	v	v	v	v	v	v	v	v	100%
-36	v	v	v	v	v	v	v	v	v	v	100%
-35	v	v	v	v	v	v	v	v	v	v	100%
-34	v	v	v	v	v	v	v	v	v	v	100%
-33	v	v	v	v	v	v	v	v	v	v	100%
-32	v	v	v	v	v	v	v	v	v	v	100%
-31	v	v	v	v	v	v	v	v	v	v	100%
-30	v	v	v	v	v	v	v	v	v	v	100%
-29	v	v	v	v	v	v	v	v	v	v	100%
-28	v	v	v	v	v	v	v	v	v	v	100%
-27	v	v	v	v	v	v	v	v	v	v	100%
-26	v	v	v	v	v	v	v	v	v	v	100%
-25	v	v	v	v	v	v	v	v	v	v	100%
-24	v	v	v	v	v	v	v	v	v	v	100%
-23	v	v	v	v	v	v	v	v	v	v	100%
-22	v	v	v	v	v	v	v	v	v	v	100%
-21	v	v	v	v	v	v	v	v	v	v	100%
-20	v	v	v	v	v	v	v	v	v	v	100%
-19	v	v	v	v	v	v	v	v	v	v	100%
-18	v	v	v	v	v	v	v	v	v	v	100%
-17	v	v	v	v	v	v	v	v	v	v	100%
-16	v	v	v	v	v	v	v	v	v	v	100%
-15	v	v	v	v	v	v	v	v	v	v	100%
-14	v	v	v	v	v	v	v	v	v	v	100%
-13	v	v	v	v	v	v	v	v	v	v	100%
-12	v	v	v	v	v	v	v	v	v	v	100%
-11	v	v	v	v	v	v	v	v	v	v	100%
-10	v	v	v	v	v	v	v	v	v	v	100%
-9	v	v	v	v	v	v	v	v	v	v	100%
-8	v	v	v	v	v	v	v	v	v	v	100%
-7	v	v	v	v	v	v	v	v	v	v	100%
-6	v	v	v	v	v	v	v	v	v	v	100%
-5	v	v	v	v	v	v	v	v	v	v	100%
-4	v	v	v	v	v	v	v	v	v	v	100%
-3	v	v	v	v	v	v	v	v	v	v	100%
-2	v	v	v	v	v	v	v	v	v	v	100%
-1	v	v	v	v	v	v	v	v	v	v	100%
F ₀	v	v	v	v	v	v	v	v	v	v	100%

This test report may be reproduced in full only. The document may only be updated by MiCOM Labs personnel. Any changes will be noted in the Document History section of the report.



Title: Aruba Networks APIN0214, APIN0215
To: FCC 47 CFR Part 15.407 & IC RSS-210
Serial #: ARUB179-U8 Rev B
Issue Date: 2nd September 2014
Page: 148 of 330

Center Frequency= 5,530 MHz, 802.11ac , HT80 (Detection = √, No Detection = 0)											
Radar Frequency (MHz)	1	2	3	4	5	6	7	8	9	10	Detection Rate (%)
F ₀	v	v	v	v	v	v	v	v	v	v	100%
+1	v	v	v	v	v	v	v	v	v	v	100%
+2	v	v	v	v	v	v	v	v	v	v	100%
+3	v	v	v	v	v	v	v	v	v	v	100%
+4	v	v	v	v	v	v	v	v	v	v	100%
+5	v	v	v	v	v	v	v	v	v	v	100%
+6	v	v	v	v	v	v	v	v	v	v	100%
+7	v	v	v	v	v	v	v	v	v	v	100%
+8	v	v	v	v	v	v	v	v	v	v	100%
+9	v	v	v	v	v	v	v	v	v	v	100%
+10	v	v	v	v	v	v	v	v	v	v	100%
+11	v	v	v	v	v	v	v	v	v	v	100%
+12	v	v	v	v	v	v	v	v	v	v	100%
+13	v	v	v	v	v	v	v	v	v	v	100%
+14	v	v	v	v	v	v	v	v	v	v	100%
+15	v	v	v	v	v	v	v	v	v	v	100%
+16	v	v	v	v	v	v	v	v	v	v	100%
+17	v	v	v	v	v	v	v	v	v	v	100%
+18	v	v	v	v	v	v	v	v	v	v	100%
+19	v	v	v	v	v	v	v	v	v	v	100%
+20	v	v	v	v	v	v	v	v	v	v	100%
+21	v	v	v	v	v	v	v	v	v	v	100%
+22	v	v	v	v	v	v	v	v	v	v	100%
+23	v	v	v	v	v	v	v	v	v	v	100%
+24	v	v	v	v	v	v	v	v	v	v	100%
+25	v	v	v	v	v	v	v	v	v	v	100%
+26	v	v	v	v	v	v	v	v	v	v	100%
+27	v	v	v	v	v	v	v	v	v	v	100%
+28	v	v	v	v	v	v	v	v	v	v	100%
+29	v	v	v	v	v	v	v	v	v	v	100%
+30	v	v	v	v	v	v	v	v	v	v	100%
+31	v	v	v	v	v	v	v	v	v	v	100%
+32	v	v	v	v	v	v	v	v	v	v	100%
+33	v	v	v	v	v	v	v	v	v	v	100%
+34	v	v	v	v	v	v	v	v	v	v	100%
+35	v	v	v	v	v	v	v	v	v	v	100%
+36	v	v	v	v	v	v	v	v	v	v	100%
+37	v	v	v	v	v	v	v	v	v	v	100%
+38	v	v	v	v	v	v	v	v	v	v	100%
+39	o	o									<90%
+40											
Detection Bandwidth = F _H -F _L = 5568 - 5491 = 77 MHz											
EUT 99% Bandwidth = 75.75 MHz (ref. bandwidth channel 100 - 112 Center 5530 MHz)											
75.75 MHz *80% = 60.6 MHz											

This test report may be reproduced in full only. The document may only be updated by MiCOM Labs personnel. Any changes will be noted in the Document History section of the report.



Title: Aruba Networks APIN0214, APIN0215
To: FCC 47 CFR Part 15.407 & IC RSS-210
Serial #: ARUB179-U8 Rev B
Issue Date: 2nd September 2014
Page: 149 of 330

6.2.2. Initial Channel Availability Check Time

This test verifies that the EUT does not emit pulse, control, or data signals on the test Channel until the power-up sequence has been completed and the U-NII device checks for Radar Waveforms for one minute on the test Channel. This test does not use any Radar Waveforms.

The U-NII device is powered on and be instructed to operate at 5,500MHz 802.11a and 5,510MHz 802.11n HT40. At the same time the EUT is powered on, the spectrum analyzer is set for zero span with a 1 MHz resolution bandwidth at 5,500, 5,510, and 5530 MHz with a 260 second sweep time. The analyzer's sweep will be started the same time power is applied to the U-NII device.

The EUT should not transmit any pulse or data transmissions until at least 1 minute after the completion of the power-on cycle.

The first red marker line shown on the following plot denotes the instant when the EUT starts its power-up sequence i.e. T_0 (as defined within the FCC's MO&O 06-96 Normative Reference 2). The power-up reference T_0 is determined by the time it takes for the EUT to start "beaconing" i.e. initial beacon – 60 secs = end of power-up.

The Channel Availability Check Time commences at instant T_0 and will end no sooner than $T_0 + 60$ seconds.

This test report may be reproduced in full only. The document may only be updated by MiCOM Labs personnel. Any changes will be noted in the Document History section of the report.



Title: Aruba Networks APIN0214, APIN0215
To: FCC 47 CFR Part 15.407 & IC RSS-210
Serial #: ARUB179-U8 Rev B
Issue Date: 2nd September 2014
Page: 150 of 330

EUT power up and Initial Channel Availability Check Time
5,500MHz 802.11a Power On = 88.57 Seconds

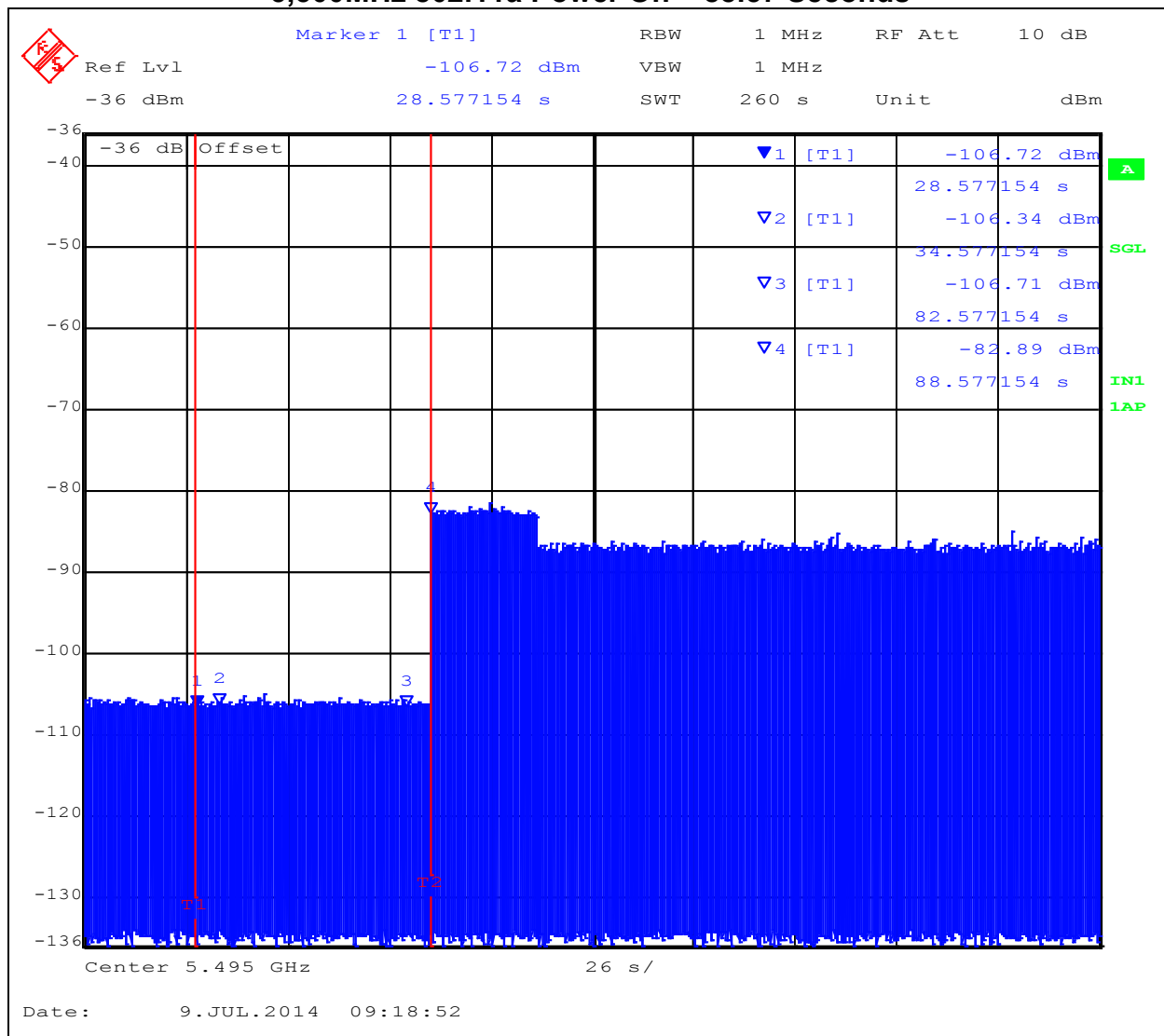

This test report may be reproduced in full only. The document may only be updated by MiCOM Labs personnel. Any changes will be noted in the Document History section of the report.



EUT power up and Initial Channel Availability Check Time
5,510MHz 802.11n HT40 Power On = 87.01 Seconds

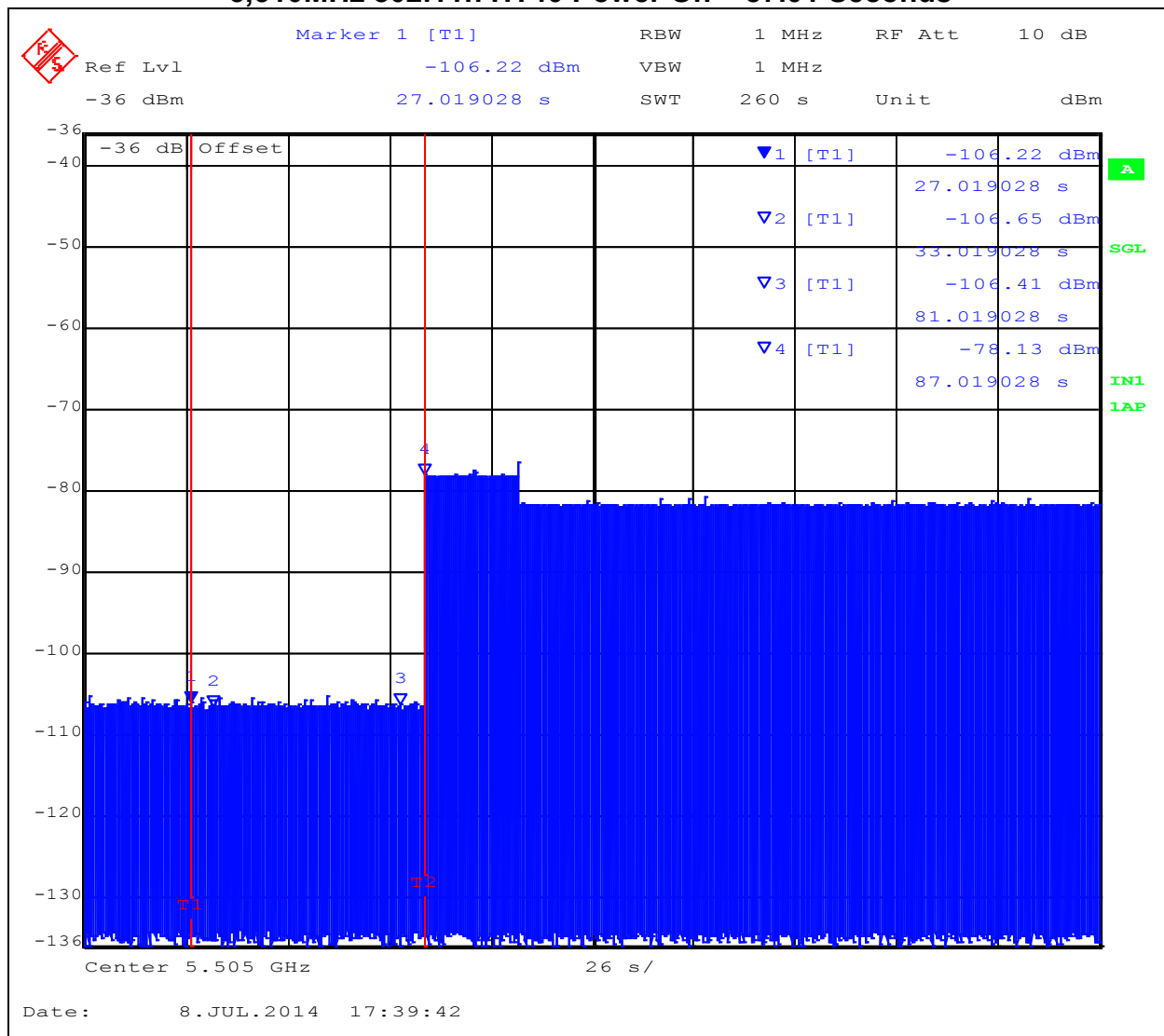

This test report may be reproduced in full only. The document may only be updated by MiCOM Labs personnel. Any changes will be noted in the Document History section of the report.



Title: Aruba Networks APIN0214, APIN0215
To: FCC 47 CFR Part 15.407 & IC RSS-210
Serial #: ARUB179-U8 Rev B
Issue Date: 2nd September 2014
Page: 152 of 330

EUT power up and Initial Channel Availability Check Time
5,530MHz 802.11ac 80 Power On = 90.14 Second

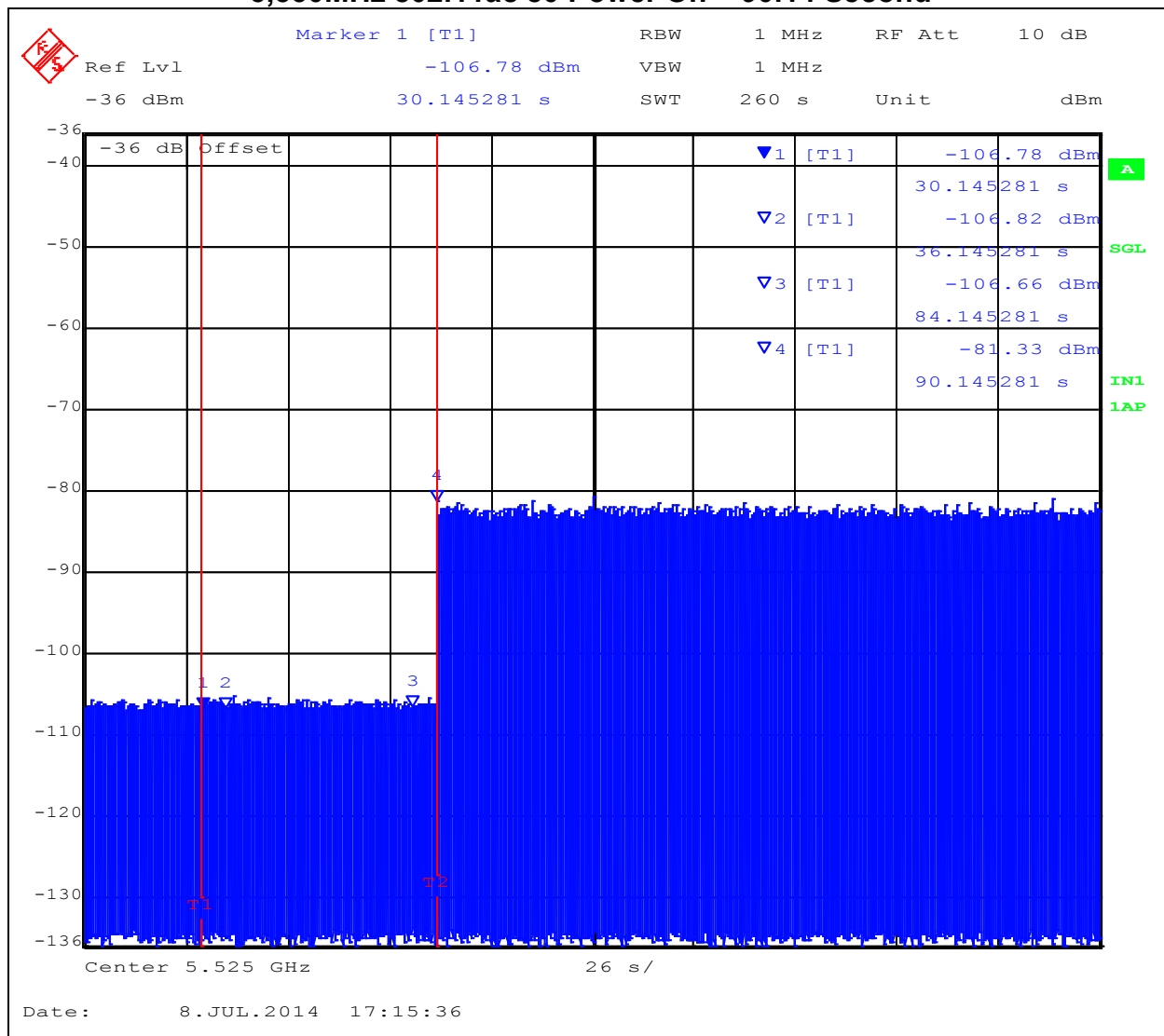

This test report may be reproduced in full only. The document may only be updated by MiCOM Labs personnel. Any changes will be noted in the Document History section of the report.



Title: Aruba Networks APIN0214, APIN0215
To: FCC 47 CFR Part 15.407 & IC RSS-210
Serial #: ARUB179-U8 Rev B
Issue Date: 2nd September 2014
Page: 153 of 330

6.2.3. Radar Burst at the Beginning of the Channel Availability Check Time:

The steps below define the procedure to verify successful radar detection on the selected Channel during a period equal to the Channel Availability Check Time and avoidance of operation on that Channel when a radar Burst with a level equal to the DFS Detection Threshold +6 dB (-62 dBm Ref Section 6.1.7) occurs at the beginning of the Channel Availability Check Time.

A single Burst of short pulse of radar Type 1 will commence within a 6 second window starting at T_0 (first red marker line on the following plot).

Visual indication on the EUT of successful detection of the radar Burst will be recorded and reported. Observation of emissions at 5,500MHz 802.11a & 5,510MHz, 802.11n HT40, 5530MHz 802.11ac 80, and will continue for 2.5 minutes after the radar burst has been generated.

This test report may be reproduced in full only. The document may only be updated by MiCOM Labs personnel. Any changes will be noted in the Document History section of the report.



Channel Availability Check Time at the start T0 + 6 seconds Check Time
5,500MHz 802.11a

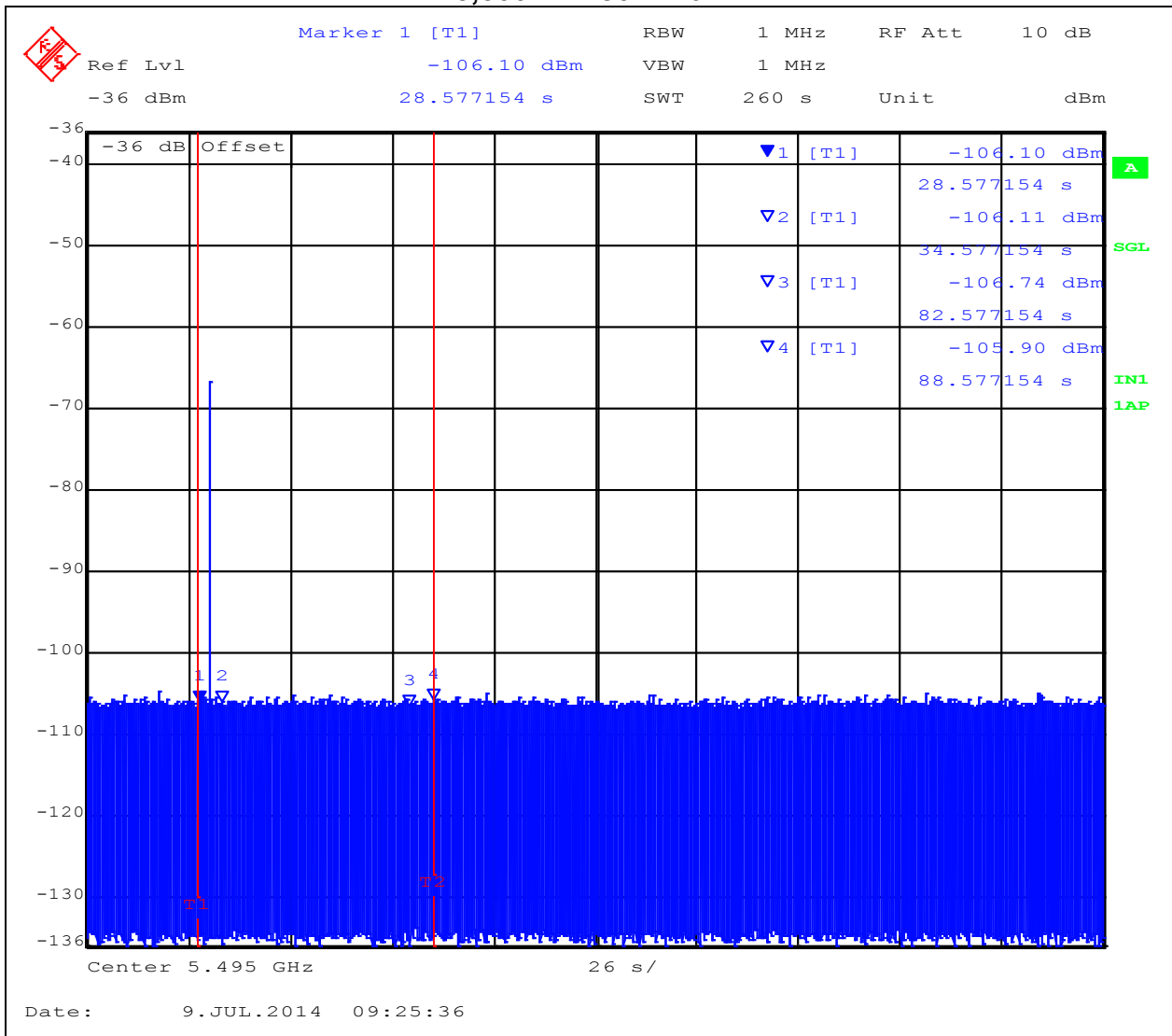

This test report may be reproduced in full only. The document may only be updated by MiCOM Labs personnel. Any changes will be noted in the Document History section of the report.



Channel Availability Check Time at the start T0 + 6 seconds Check Time
5,510MHz 802.11n HT40

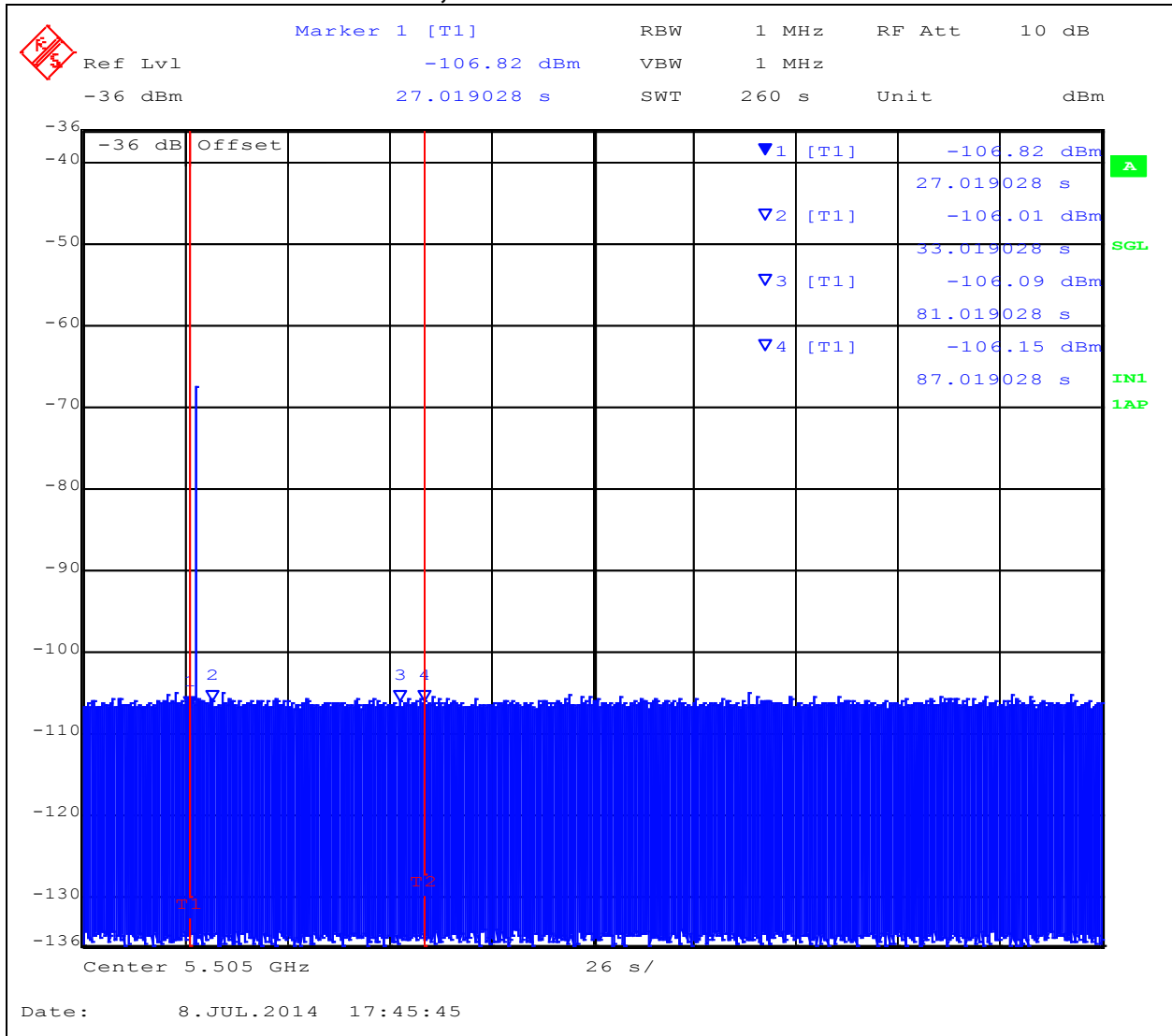

This test report may be reproduced in full only. The document may only be updated by MiCOM Labs personnel. Any changes will be noted in the Document History section of the report.



Channel Availability Check Time at the start T0 + 6 seconds Check Time
5,530MHz 802.11ac 80

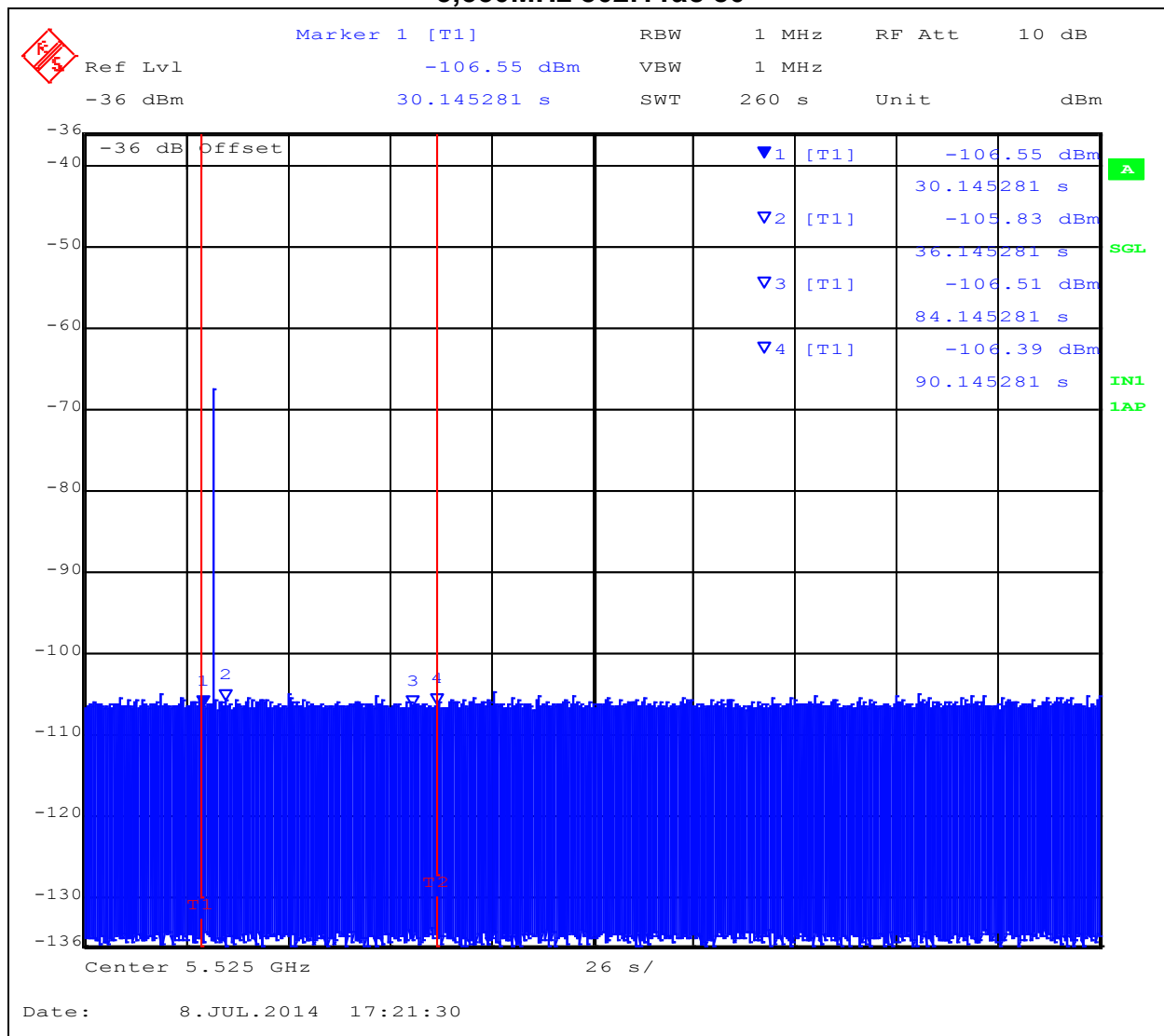

This test report may be reproduced in full only. The document may only be updated by MiCOM Labs personnel. Any changes will be noted in the Document History section of the report.



Title: Aruba Networks APIN0214, APIN0215
To: FCC 47 CFR Part 15.407 & IC RSS-210
Serial #: ARUB179-U8 Rev B
Issue Date: 2nd September 2014
Page: 157 of 330

6.2.4. Radar Burst at the End of the Channel Availability Check Time:

The steps below define the procedure to verify successful radar detection on the selected Channel during a period equal to the Channel Availability Check Time and avoidance of operation on that Channel when a radar Burst with a level equal to the DFS Detection Threshold occurs at the end of the Channel Availability Check Time.

A single Burst of short pulse of radar type 1 will commence within a 6 second window starting at $T_0 + 54$ seconds. The window will commence at marker 2 and end at the red frequency line T_2 .

Visual indication on the EUT of successful detection of the radar Burst will be recorded and reported. Observation of emissions at 5,500MHz 802.11a, 5,510MHz 802.11n HT40, 5530MHz 802.11ac 80 will continue for 2.5 minutes after the radar burst has been generated.

This test report may be reproduced in full only. The document may only be updated by MiCOM Labs personnel. Any changes will be noted in the Document History section of the report.



Channel Availability Check Time at T0 + 54 seconds Check Time
5,500MHz 802.11a

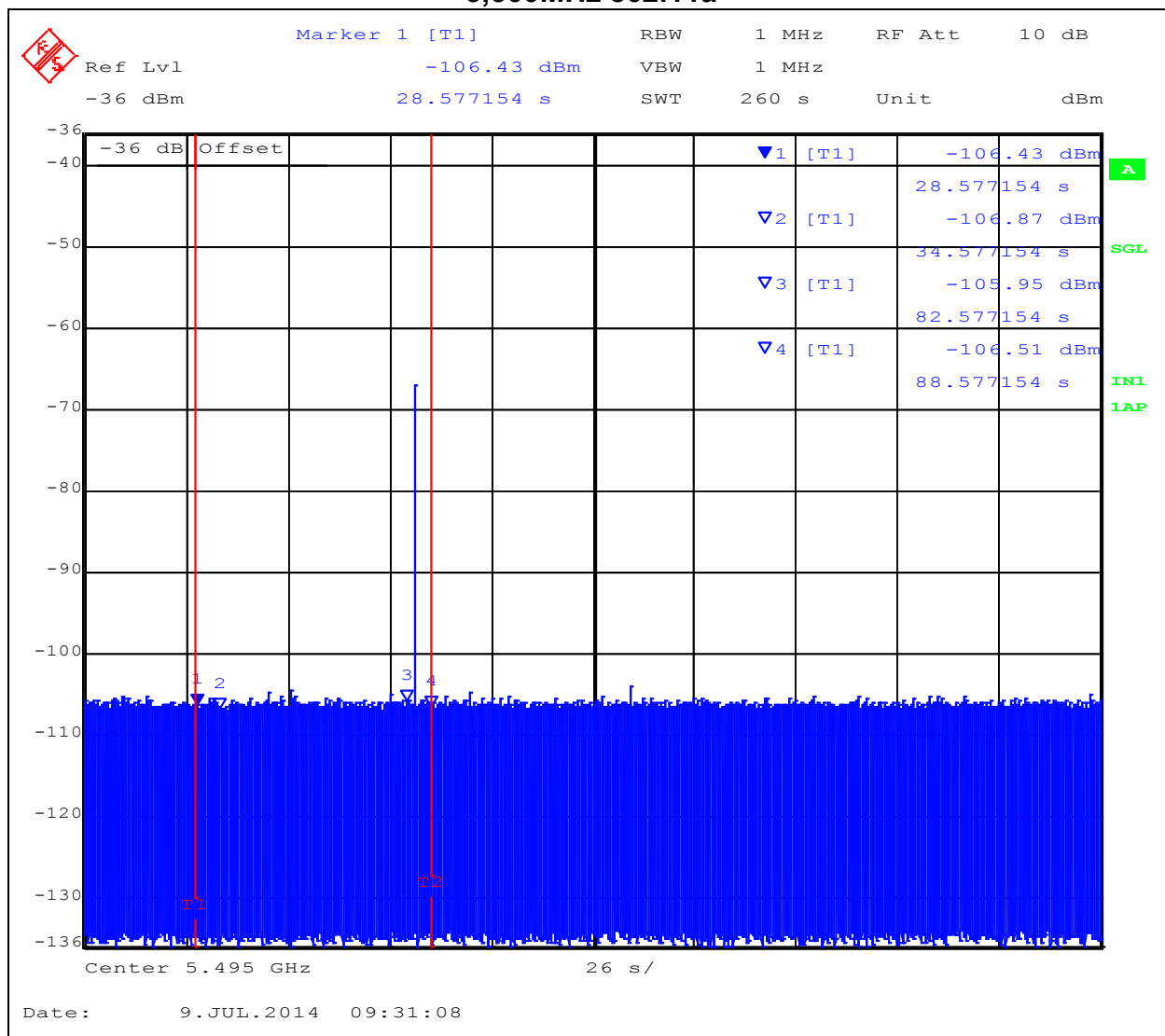

This test report may be reproduced in full only. The document may only be updated by MiCOM Labs personnel. Any changes will be noted in the Document History section of the report.



Channel Availability Check Time at T0 + 54 seconds Check Time
5,510MHz 802.11n HT40

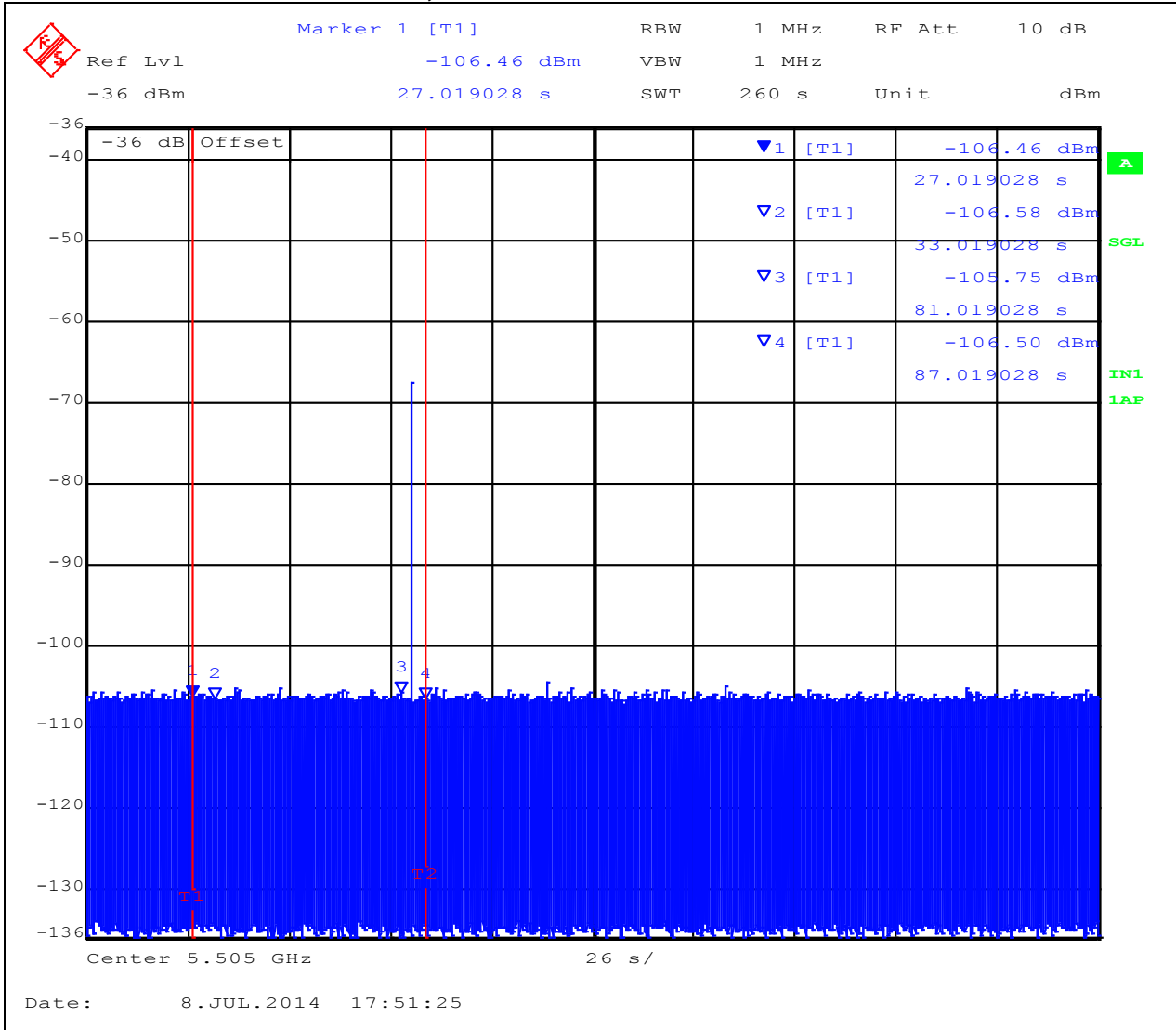

This test report may be reproduced in full only. The document may only be updated by MiCOM Labs personnel. Any changes will be noted in the Document History section of the report.



Title: Aruba Networks APIN0214, APIN0215
To: FCC 47 CFR Part 15.407 & IC RSS-210
Serial #: ARUB179-U8 Rev B
Issue Date: 2nd September 2014
Page: 160 of 330

Channel Availability Check Time at T0 + 54 seconds Check Time 5,530MHz 802.11ac 80

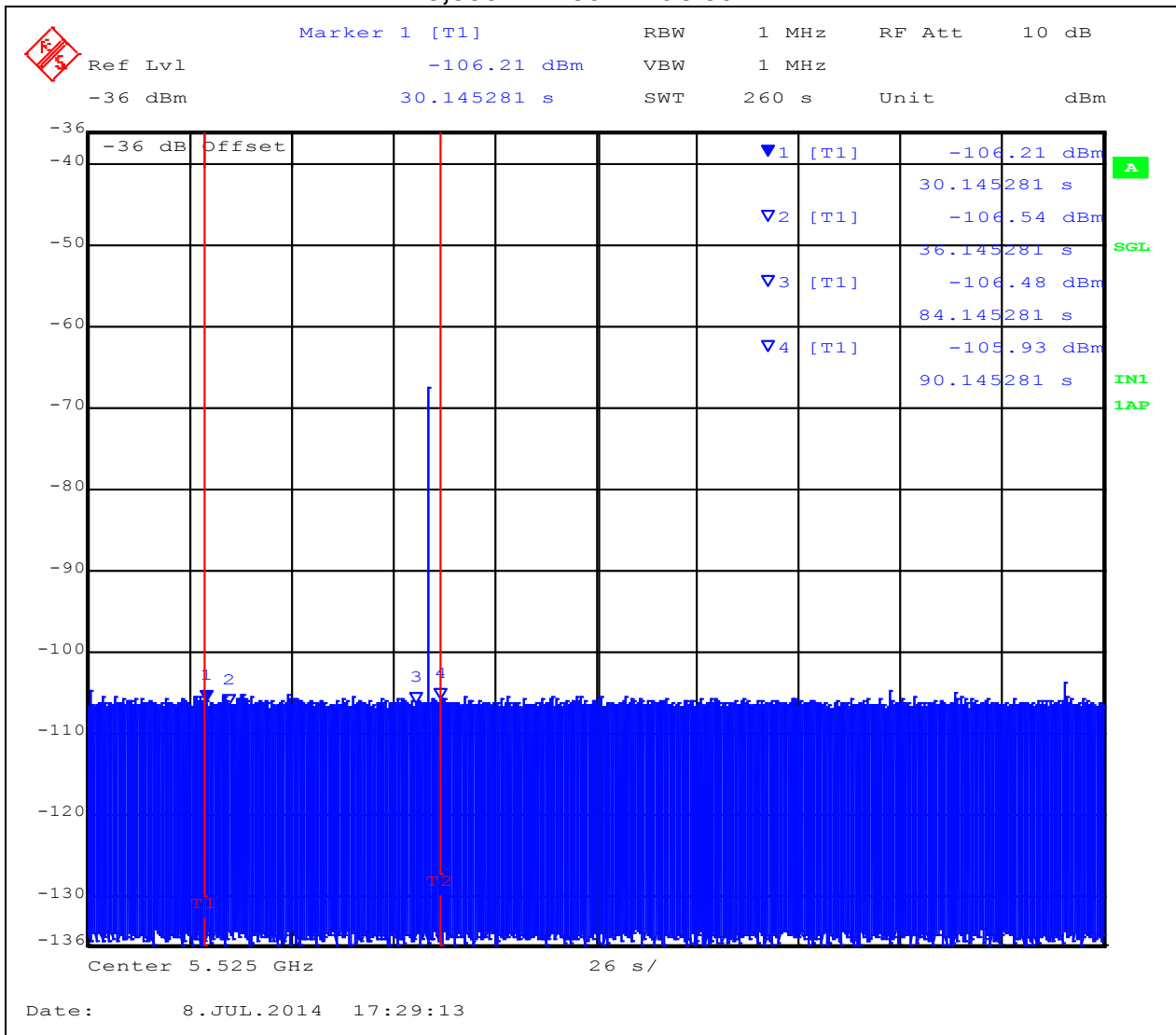

This test report may be reproduced in full only. The document may only be updated by MiCOM Labs personnel. Any changes will be noted in the Document History section of the report.



Title: Aruba Networks APIN0214, APIN0215
To: FCC 47 CFR Part 15.407 & IC RSS-210
Serial #: ARUB179-U8 Rev B
Issue Date: 2nd September 2014
Page: 161 of 330

6.2.5. In-Service Monitoring for Channel Move Time, Channel Closing Transmission Time and Non-Occupancy Period

FCC §15.407(h)(2)(iii)

The steps below define the procedure to determine the above mentioned parameters when a radar Burst with a level equal to the DFS Detection Threshold is generated on the Operating Channel of the U-NII device.

A U-NII device operating as a Client Device will associate with the EUT (Master). The requisite MPEG video file ("TestFile.mpg" available on the NTIA website at the following link <http://ntiacsd.ntia.doc.gov/dfs/>) is streamed from the master device (AP) to the client.

Channel Closing Transmission Time and Channel Mode Time - Measurement

The test system was set-up to capture all transmission data for access point events above a threshold level of -50 dBm. The test equipment time stamps all captured events.

A Type 1 waveform was introduced to the EUT, from which a 12 second transmission record was digitally captured. The start of the Type 1 radar waveform is indicated in the test result plot as "Start Waveform", the end of the waveform is indicated as "End waveform".

Channel Closing Transmission Time, and the Channel Move Time start immediately after the last radar pulse is transmitted.

The aggregate of all pulses seen after the end of the radar injection are measured as the "Channel Closing Transmission time".

The last EUT activity after the end of the radar pulse is identified and used to determine the "Channel Mode Time"



Title: Aruba Networks APIN0214, APIN0215
To: FCC 47 CFR Part 15.407 & IC RSS-210
Serial #: ARUB179-U8 Rev B
Issue Date: 2nd September 2014
Page: 162 of 330

Channel Closing Transmission Time 5,500 MHz (802.11a) = 0.00 Secs (limit 260 mSecs)

Channel Move Time 5,500MHz (802.11a) = 4.42 Secs (limit 10 Secs)

Channel Move Time, Channel Closing Transmission Time for Type 1 Radar Captured by the Test System - 0 to 12 seconds

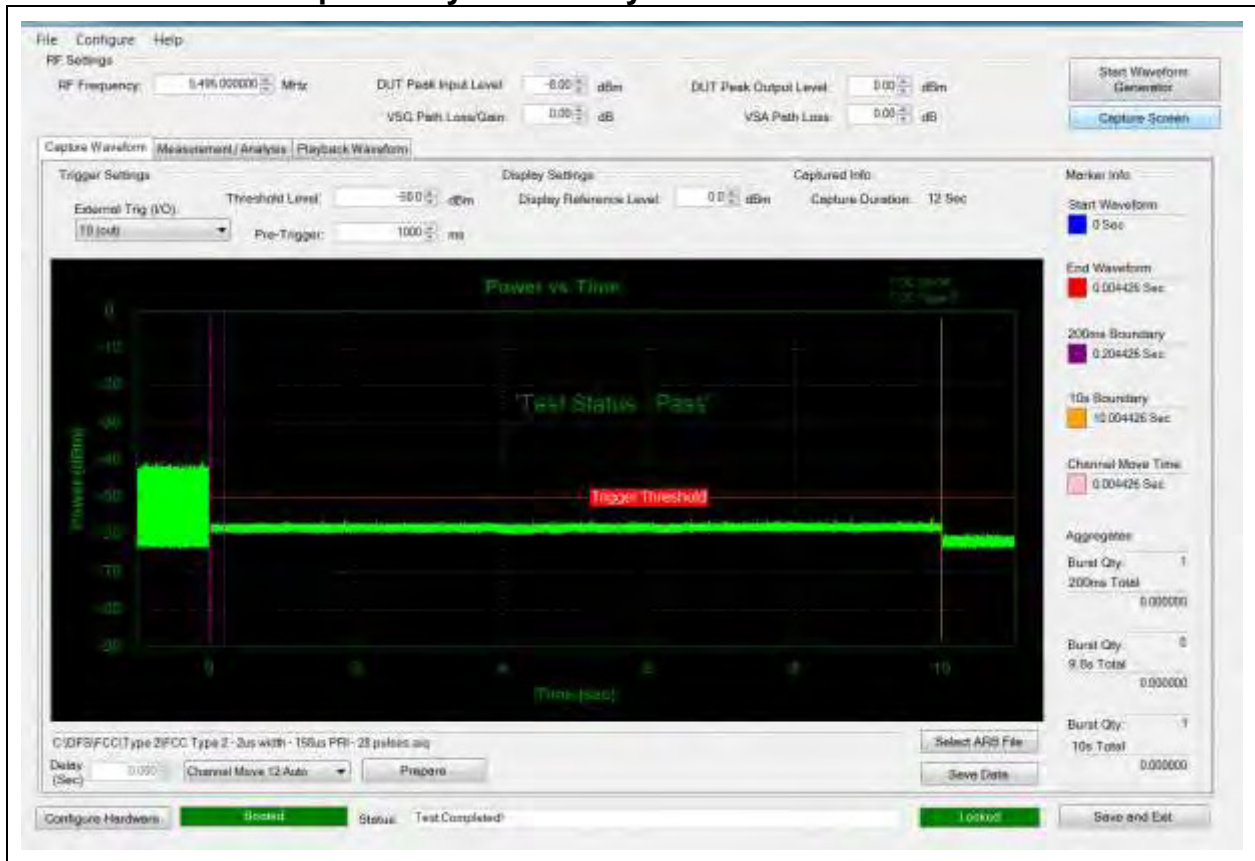

This test report may be reproduced in full only. The document may only be updated by MiCOM Labs personnel. Any changes will be noted in the Document History section of the report.



Title: Aruba Networks APIN0214, APIN0215
To: FCC 47 CFR Part 15.407 & IC RSS-210
Serial #: ARUB179-U8 Rev B
Issue Date: 2nd September 2014
Page: 163 of 330

Channel Closing Transmission Time 5,510 MHz (802.11n HT40) = 6.71 mSecs
(limit 260 mSecs)

Channel Move Time 5,510 MHz (802.11n HT40) = 146.74 mSecs (limit 10 Secs)

**Channel Move Time, Channel Closing Transmission Time for Type 1 Radar
Captured by the Test System - 0 to 12 seconds**

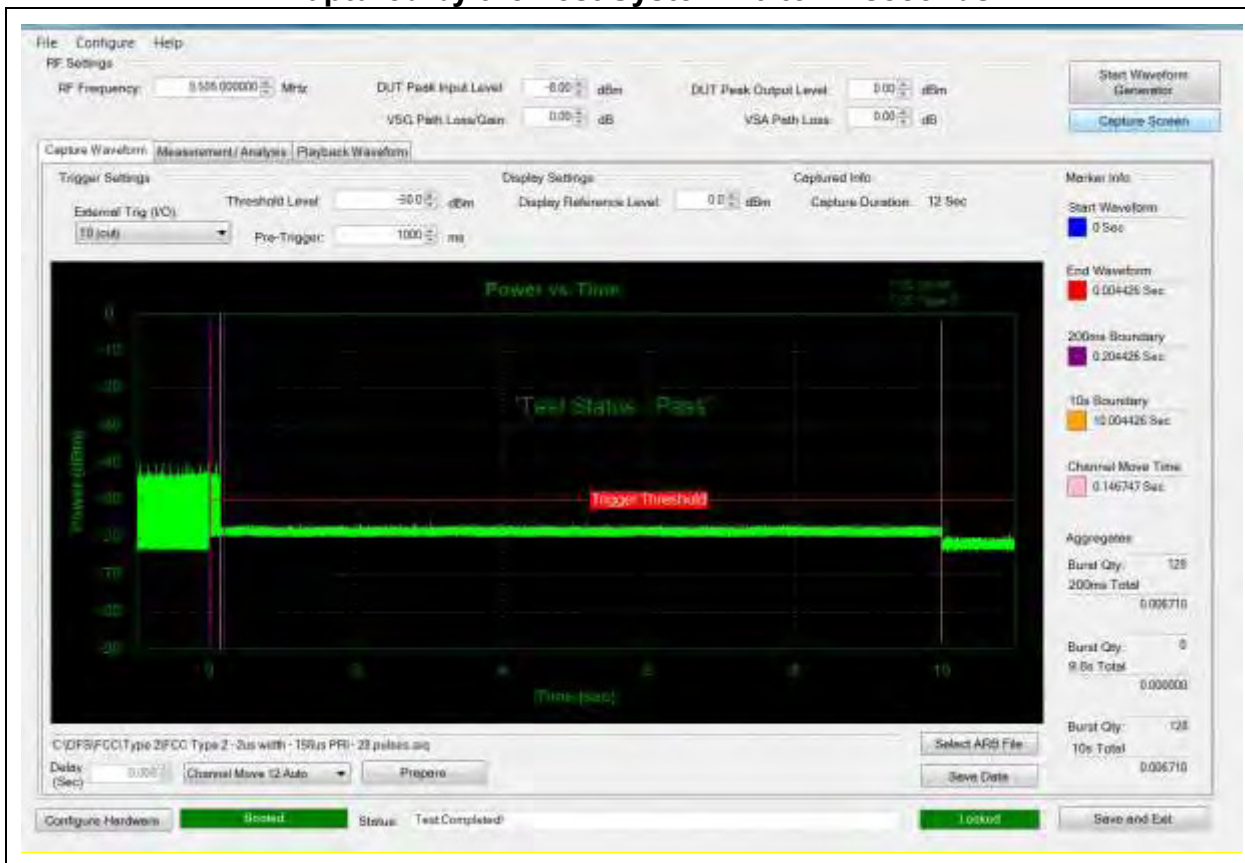

This test report may be reproduced in full only. The document may only be updated by MiCOM Labs personnel. Any changes will be noted in the Document History section of the report.



Title: Aruba Networks APIN0214, APIN0215
To: FCC 47 CFR Part 15.407 & IC RSS-210
Serial #: ARUB179-U8 Rev B
Issue Date: 2nd September 2014
Page: 164 of 330

Channel Closing Transmission Time 5,510 MHz (802.11n HT40) = 0.00 Secs (limit 260 mSecs)

Channel Move Time 5,530 MHz (802.11ac 80) = 9.46 mSecs (limit 10 Secs)

Channel Move Time, Channel Closing Transmission Time for Type 1 Radar Captured by the Test System - 0 to 12 seconds

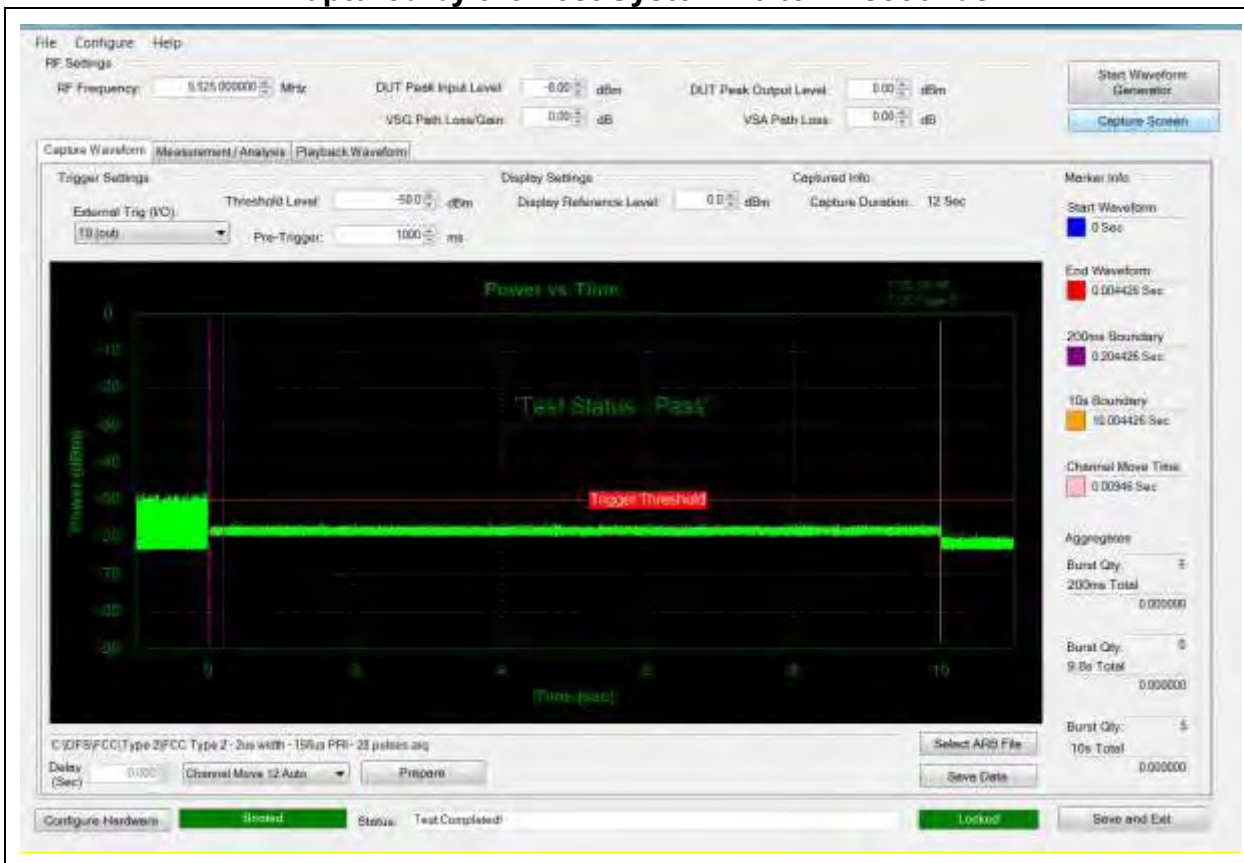

This test report may be reproduced in full only. The document may only be updated by MiCOM Labs personnel. Any changes will be noted in the Document History section of the report.



Title: Aruba Networks APIN0214, APIN0215
To: FCC 47 CFR Part 15.407 & IC RSS-210
Serial #: ARUB179-U8 Rev B
Issue Date: 2nd September 2014
Page: 168 of 330

6.2.6. Statistical Performance Check

The steps below define the procedure to determine the minimum percentage of detection when a radar burst with a level equal to the DFS Detection Threshold is generated on the Operating Channel of the U-NII device.

A U-NII device operating as a Client Device will associate with the UUT (Master) at 5,500MHz 802.11a, 5,510MHz 802.11n HT40, and 802.11ac 80.

The Radar Waveform generator sends the individual waveform for each of the radar types 1-6. Statistical data will be gathered to determine the ability of the device to detect the radar test waveforms. The device can utilize a test mode to demonstrate when detection occurs to prevent the need to reset the device between trial runs. The percentage of successful detection is calculated by:

$$\text{Total \# of detections} \div \text{Total \# of Trials} \times 100 = \text{Probability of Detection}$$

The Minimum number of trails, minimum percentage of successful detection and the average minimum percentage of successful detection are found in the Radar Test Waveforms section.

This test report may be reproduced in full only. The document may only be updated by MiCOM Labs personnel. Any changes will be noted in the Document History section of the report.



Verification of Detection 5,500MHz 802.11a (Offset 5MHz)

Trial #	Detection = √, No Detection = 0					
	Type 1	Type 2	Type 3	Type 4	Type 5	Type 6
1	√	√	√	√	√	√
2	√	√	√	√	√	√
3	√	√	√	√	√	√
4	√	√	0	√	√	√
5	√	√	√	√	√	√
6	√	√	√	√	√	√
7	√	√	√	√	√	√
8	√	√	√	√	0	0
9	√	√	√	√	0	√
10	√	0	√	√	√	√
11	√	√	√	√	0	√
12	√	√	√	√	√	√
13	√	√	√	√	√	√
14	√	√	√	√	√	√
15	√	√	√	√	√	√
16	√	√	√	√	√	√
17	√	√	√	√	√	√
18	√	√	√	√	√	√
19	√	√	√	√	√	√
20	√	√	√	√	0	√
21	√	√	√	√	√	0
22	√	√	√	√	√	√
23	√	√	√	√	√	√
24	√	√	√	√	√	√
25	√	√	√	√	√	√
26	√	√	√	√	√	√
27	√	√	√	√	√	√
28	√	√	√	√	√	√
29	√	√	√	√	√	√
30	√	√	√	√	0	√
Detection Percentage	100% (>60%)	96.6% (>60%)	96.6% (>60%)	100% (>60%)	86.6% (>80%)	93.3% (>70%)

In addition an average minimum percentage of successful detection across all four Short pulse radar test waveforms is required and calculated as follows;

$$(P_{d1} + P_{d2} + P_{d3} + P_{d4}) / 4 = (100\% + 96.6\% + 96.6\% + 100\%) / 4 = 98.3\% (> 80\%)$$



Verification of Detection 5,510MHz 802.11n HT40 (Offset 5MHz)

Trial #	Detection = √, No Detection = 0					
	Type 1	Type 2	Type 3	Type 4	Type 5	Type 6
1	√	√	√	√	√	√
2	√	√	√	√	√	√
3	√	√	√	√	√	√
4	√	√	√	√	√	√
5	√	√	0	√	√	√
6	√	√	√	√	√	√
7	√	√	√	√	√	√
8	√	√	√	√	√	√
9	√	√	√	√	√	√
10	√	√	√	√	√	√
11	√	√	√	√	0	√
12	√	√	√	√	√	√
13	√	√	√	√	√	√
14	√	√	√	√	√	√
15	√	√	√	√	√	√
16	√	√	√	√	√	√
17	√	√	√	√	√	√
18	√	√	√	√	0	√
19	√	√	√	√	√	√
20	√	√	√	√	0	√
21	√	√	√	√	√	√
22	√	√	√	√	√	√
23	√	√	√	√	0	√
24	√	√	√	√	√	√
25	√	√	√	√	√	√
26	√	√	√	√	√	√
27	√	√	√	√	√	√
28	√	√	√	√	√	√
29	√	√	√	√	√	√
30	√	√	√	√	√	√
Detection Percentage	100% (>60%)	100% (>60%)	96.6% (>60%)	100% (>60%)	86.6% (>80%)	100% (>70%)

In addition an average minimum percentage of successful detection across all four Short pulse radar test waveforms is required and calculated as follows;

$$(P_{d1} + P_{d2} + P_{d3} + P_{d4}) / 4 = (100\% + 100\% + 96.6\% + 100\%) / 4 = 99.15\% (> 80\%)$$

This test report may be reproduced in full only. The document may only be updated by MiCOM Labs personnel. Any changes will be noted in the Document History section of the report.



Verification of Detection 5,530MHz 802.11ac HT80 (Offset 5MHz)

Trial #	Detection = √, No Detection = 0					
	Type 1	Type 2	Type 3	Type 4	Type 5	Type 6
1	√	√	√	√	√	√
2	√	√	√	√	√	√
3	√	√	√	√	√	√
4	√	√	√	√	√	√
5	√	√	0	√	√	√
6	√	√	√	√	√	√
7	√	√	√	√	√	√
8	√	√	√	√	0	√
9	√	√	√	√	√	√
10	√	√	√	√	0	√
11	√	√	√	√	0	√
12	√	√	√	√	√	√
13	√	√	√	√	√	√
14	√	√	√	√	√	√
15	√	√	√	√	√	√
16	√	√	√	√	√	√
17	√	√	√	√	0	√
18	√	√	√	√	0	√
19	√	√	√	√	√	√
20	√	√	√	√	√	√
21	√	√	√	√	√	√
22	√	√	√	√	√	√
23	√	√	√	√	√	√
24	√	√	0	√	√	√
25	√	√	√	√	√	√
26	√	√	√	√	√	√
27	√	√	√	√	√	√
28	√	√	√	√	√	√
29	√	√	√	√	√	√
30	√	√	√	√	√	√
Detection Percentage	100% (>60%)	100% (>60%)	96.6% (>60%)	100% (>60%)	83.3% (>80%)	100% (>70%)

In addition an average minimum percentage of successful detection across all four Short pulse radar test waveforms is required and calculated as follows;

$$(P_{d1} + P_{d2} + P_{d3} + P_{d4}) / 4 = (100\% + 100\% + 96.6\% + 93.3\%) / 4 = 99.15\% (> 80\%)$$

This test report may be reproduced in full only. The document may only be updated by MiCOM Labs personnel. Any changes will be noted in the Document History section of the report.



Title: Aruba Networks APIN0214, APIN0215
To: FCC 47 CFR Part 15.407 & IC RSS-210
Serial #: ARUB179-U8 Rev B
Issue Date: 2nd September 2014
Page: 172 of 330

Measurement Uncertainty Time/Power

Measurement uncertainty		
- Time		4%
- Power		1.33dB

This test report may be reproduced in full only. The document may only be updated by MiCOM Labs personnel. Any changes will be noted in the Document History section of the report.

7. PHOTOGRAPHS

7.1. Conducted Test Setup



This test report may be reproduced in full only. The document may only be updated by MiCOM Labs personnel. Any changes will be noted in the Document History section of the report.

7.2. Test Setup - Digital Emissions > 1 GHz

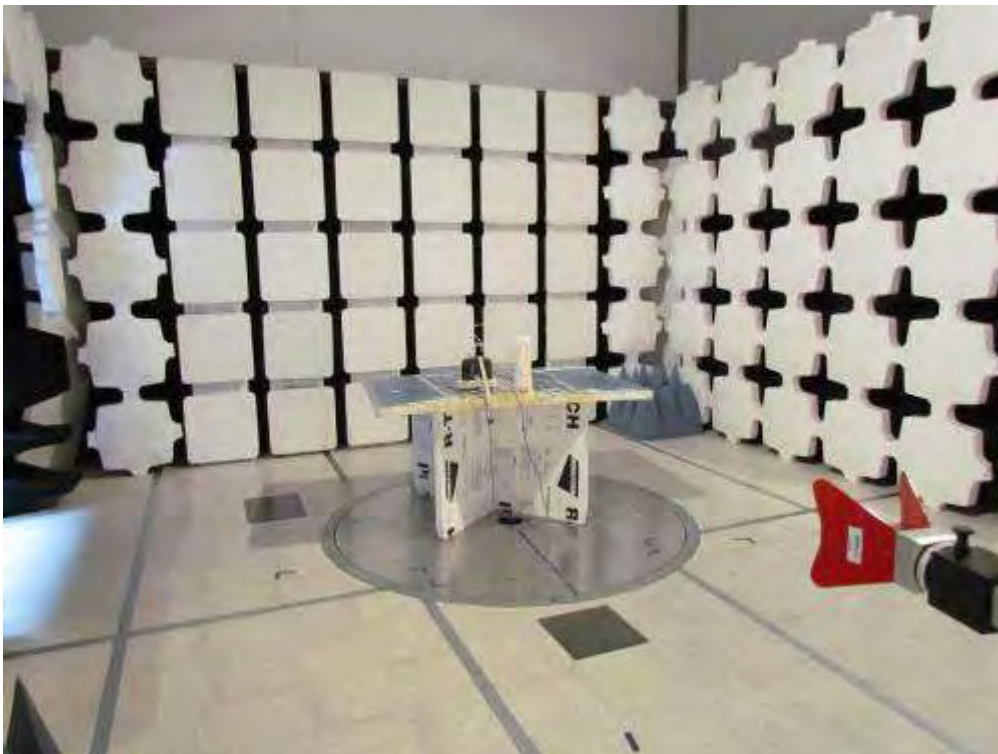
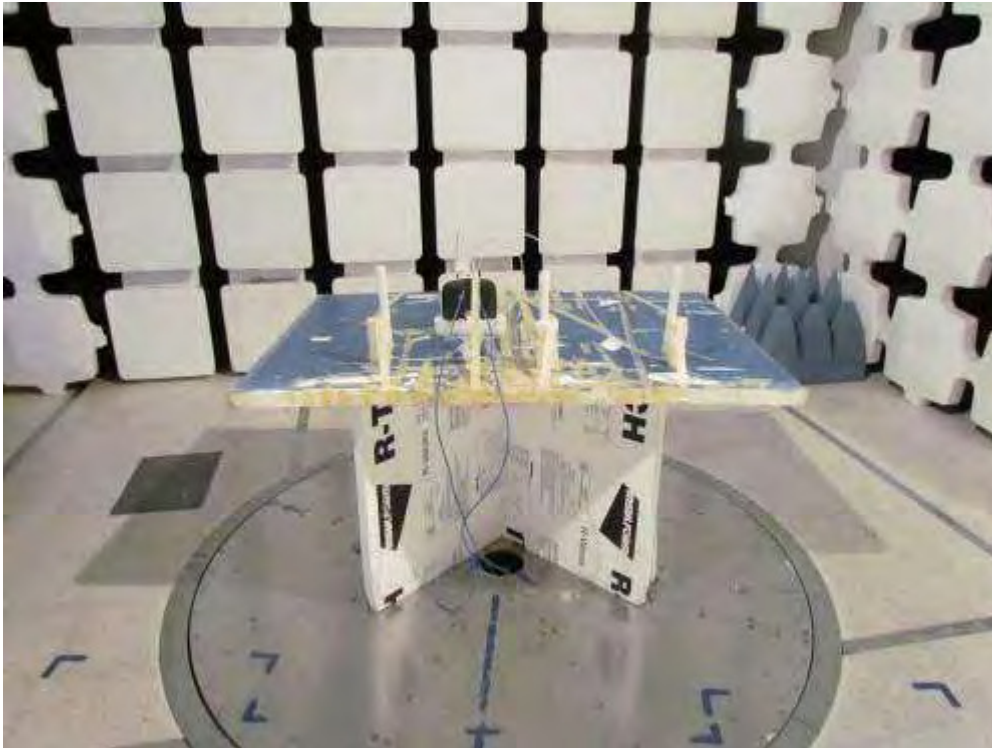

This test report may be reproduced in full only. The document may only be updated by MiCOM Labs personnel. Any changes will be noted in the Document History section of the report.

7.3. Radiated Emissions Test Setup <1 GHz

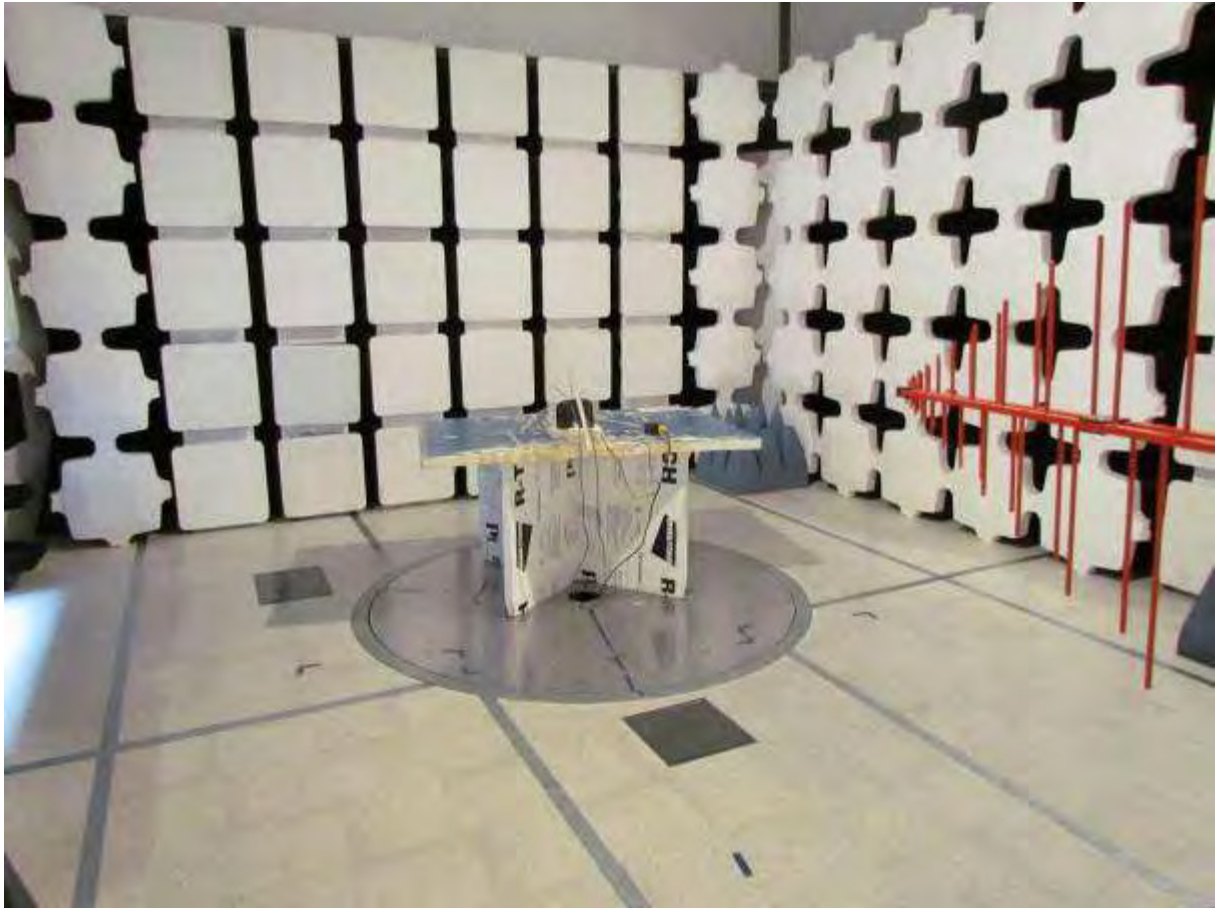

This test report may be reproduced in full only. The document may only be updated by MiCOM Labs personnel. Any changes will be noted in the Document History section of the report.

7.4. ac Wireline Test Setup



This test report may be reproduced in full only. The document may only be updated by MiCOM Labs personnel. Any changes will be noted in the Document History section of the report.

7.5. Dynamic Frequency Selection (DFS)

DFS Test Setup

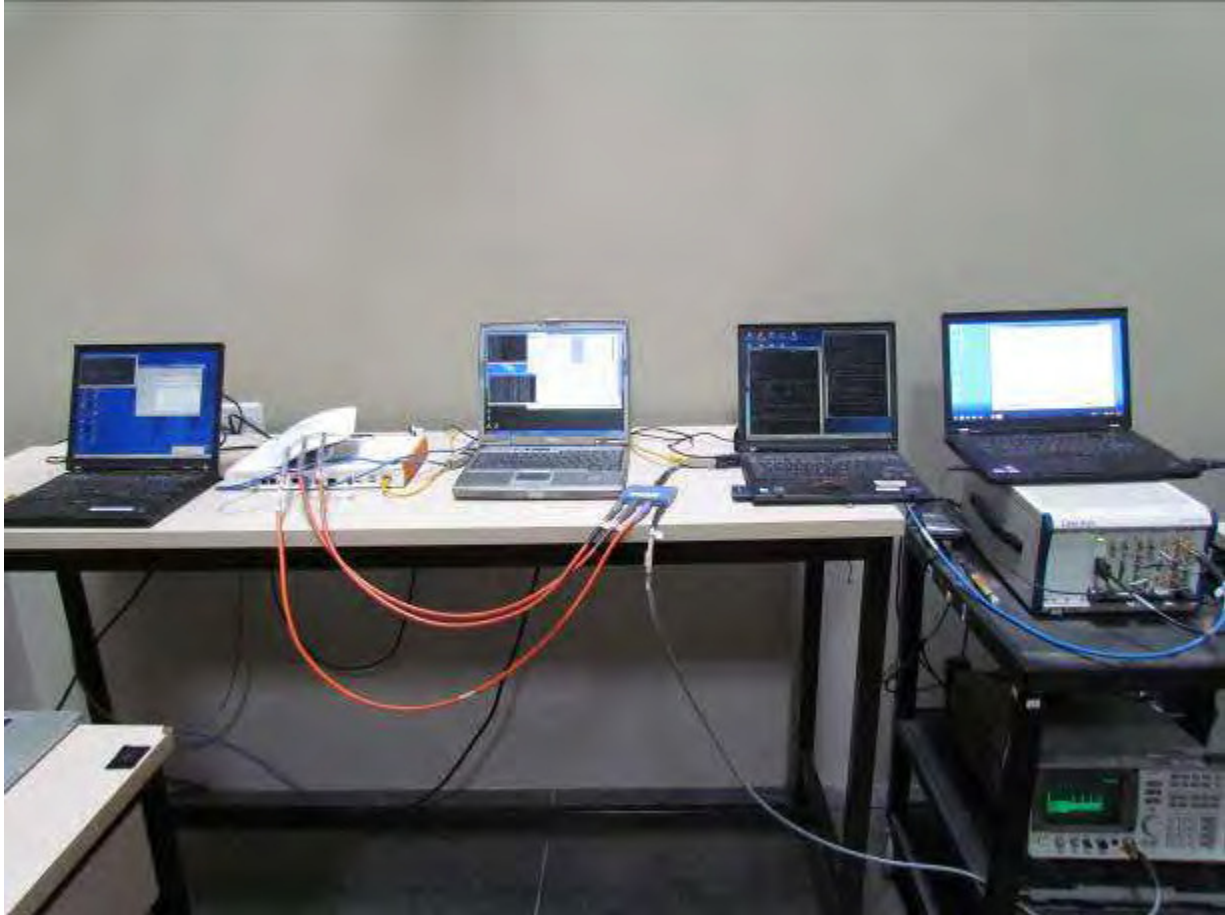

This test report may be reproduced in full only. The document may only be updated by MiCOM Labs personnel. Any changes will be noted in the Document History section of the report.

DFS Test Equipment



This test report may be reproduced in full only. The document may only be updated by MiCOM Labs personnel. Any changes will be noted in the Document History section of the report.



Title: Aruba Networks APIN0214, APIN0215
To: FCC 47 CFR Part 15.407 & IC RSS-210
Serial #: ARUB179-U8 Rev B
Issue Date: 2nd September 2014
Page: 179 of 330

8. TEST EQUIPMENT DETAILS

Asset #	Instrument	Manufacturer	Part #	Serial #	Calibration Due Date
075	Environmental Chamber	Thermatron	SE-300-2-2	27946	N/A
091	Synthesized Sweeper	Hewlett Packard	HP 83640L	3722A00249	N/A
117	Power Sensor	Hewlett Packard	8487D	3318A00371	18 th Oct '14
158	Barometer /Thermometer	Control Co.	4196	E2846	6 th Dec '14
190	Line Impedance Stabilization Network	Rhode & Schwartz	ESH3Z5	836679/006	12 Sep '14
223	Power Meter	Hewlett Packard	EPM-442A	US37480256	18 th Oct '14
252	SMA Cable	Megaphase	Sucoflex 104	None	N/A
310	2m SMA Cable	Micro-Coax	UFA210A-0-0787-3G03G0	209089-001	N/A
312	3m SMA Cable	Micro-Coax	UFA210A-1-1181-3G0300	209092-001	N/A
338	30 - 3000 MHz Antenna	Sunol	JB3	A052907	14 th Aug '14
359	DFS Radar Generator	Aeroflex	PXI-1042	300001/004	14 th Mar 2015
376	Power Sensor	Agilent	U2000A	MY514440005	28 th Oct '14
377	Notch Filter 5G	Microtronics	BRM50716	034	N/A
378	EMI Receiver	Rhode & Schwartz	ESIB40	100107/040	17 th Jul '15
380	MiTest	MiCOM Labs	MIC001	MIC001	20 th Dec '14
390	Power Sensor	Agilent	U2002A	MY50000103	17 th Oct '14
393	Low Pass Filter 1050MHz	Minicircuits	WLFX-1050		N/A
396	Notch Filter 2.4G	Microtronics	BRM50701		N/A
397	Preamp 10-2500 MHz	MiCOM Labs		0397	23 Oct '14
398	RF Conducted Test Software	MiCOM Labs ATS	--	Version 1.8	N/A

This test report may be reproduced in full only. The document may only be updated by MiCOM Labs personnel. Any changes will be noted in the Document History section of the report.



Title: Aruba Networks APIN0214, APIN0215
To: FCC 47 CFR Part 15.407 & IC RSS-210
Serial #: ARUB179-U8 Rev B
Issue Date: 2nd September 2014
Page: 180 of 330

Asset #	Instrument	Manufacturer	Part #	Serial #	Calibration Due Date
399	Horn Antenna 1-18G	ETS	3117	00154575	10 Oct '14
405	Power Supply 0 -60 Vdc	Agilent	6654A	MY4001826	N/A
406	Preamp 1-18 GHz	MiCOM Labs		0406	30 May '15
411	Mast/Turntable Control	Sunol Sciences	SC98V	060199-1D	N/A
413	Mast Controller	Sunol Sciences	TWR95-4	030801-3	N/A
415	Turntable Controller	Sunol Sciences		0415	N/A
416	Gigabit Ethernet Filter	ETS	260366	0416	N/A
502	EMC Test Software	EMISoft	Vasona	5.0051	N/A
503	RF Conducted Test Software	National Instruments	Labview	Version 8.2	N/A
RF#1SMA #SA	SMA Cable	Flexco	--	--	20 th Dec '14
RF#1SMA #1	SMA Cable	Flexco	--	--	20 th Dec '14
RF#1SMA #2	SMA Cable	Flexco	--	--	20 th Dec '14
RF#1SMA #3	SMA Cable	Flexco	--	--	20 th Dec '14
RF#1SMA #4	SMA Cable	Flexco	--	--	20 th Dec '14

This test report may be reproduced in full only. The document may only be updated by MiCOM Labs personnel. Any changes will be noted in the Document History section of the report.



Title: Aruba Networks APIN0214, APIN0215
To: FCC 47 CFR Part 15.407 & IC RSS-210
Serial #: ARUB179-U8 Rev B
Issue Date: 2nd September 2014
Page: 181 of 330

APPENDIX

A. SUPPORTING INFORMATION

A.1. CONDUCTED TEST PLOTS

This test report may be reproduced in full only. The document may only be updated by MiCOM Labs personnel. Any changes will be noted in the Document History section of the report.



A.1.1. 26 dB & 99% Bandwidth



26 dB & 99% BANDWIDTH

Variant: 802.11a, Channel: 5260.00 MHz, Chain a, Temp: Ambient, Voltage: 12 Vdc

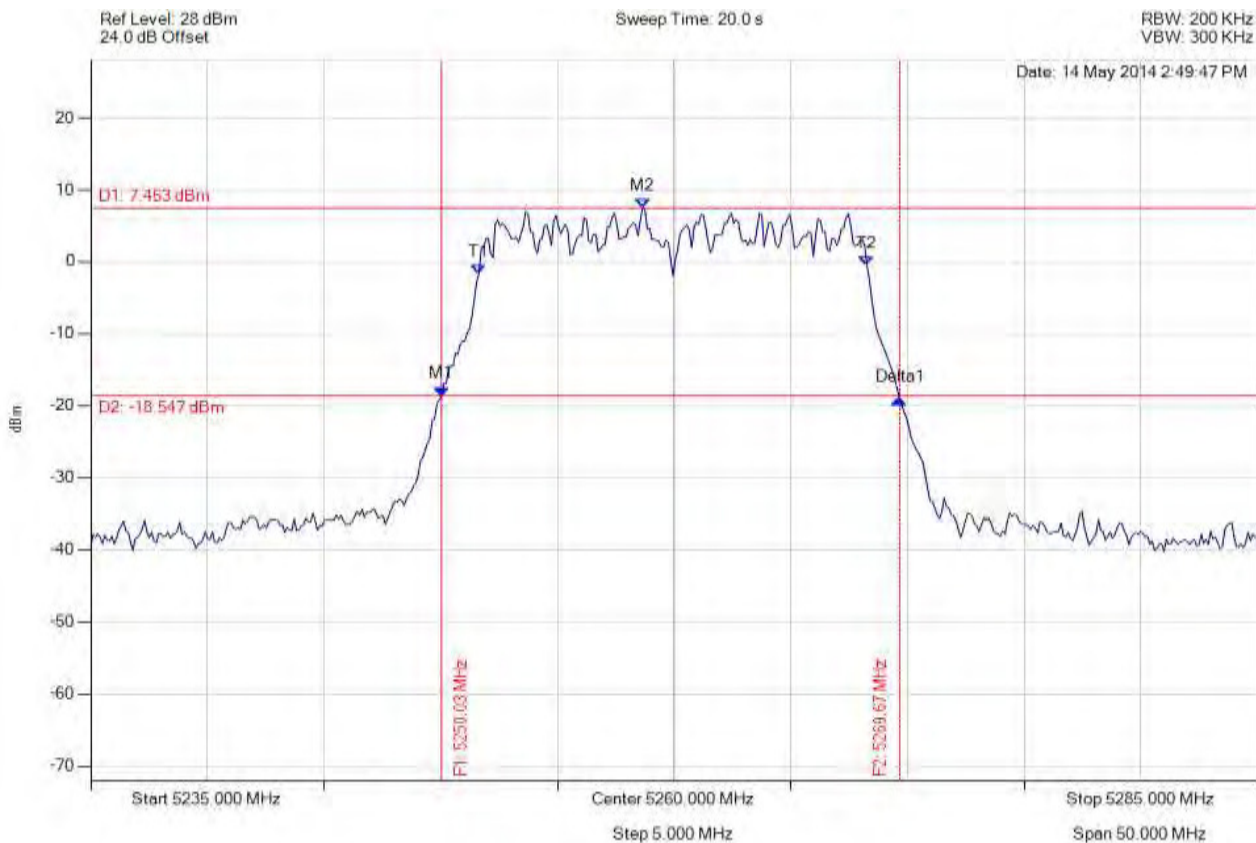

Analyser Setup	Marker : Frequency : Amplitude	Test Results
Detector = MAX PEAK Sweep Count = 0 RF Atten (dB) = 20 Trace Mode = VIEW	M1 : 5250.030 MHz : -18.628 dBm M2 : 5258.647 MHz : 7.453 dBm Delta1 : 19.639 MHz : -0.382 dB T1 : 5251.633 MHz : -1.636 dBm T2 : 5268.267 MHz : -0.548 dBm OBW : 16.633 MHz	Measured 26 dB Bandwidth : 19.639 MHz Measured 99% Bandwidth: 16.633 MHz

[Back to the Matrix](#)

This test report may be reproduced in full only. The document may only be updated by MiCOM Labs personnel. Any changes will be noted in the Document History section of the report.



Title: Aruba Networks APIN0214, APIN0215
To: FCC 47 CFR Part 15.407 & IC RSS-210
Serial #: ARUB179-U8 Rev B
Issue Date: 2nd September 2014
Page: 183 of 330



26 dB & 99% BANDWIDTH

Variant: 802.11a, Channel: 5260.00 MHz, Chain b, Temp: Ambient, Voltage: 12 Vdc

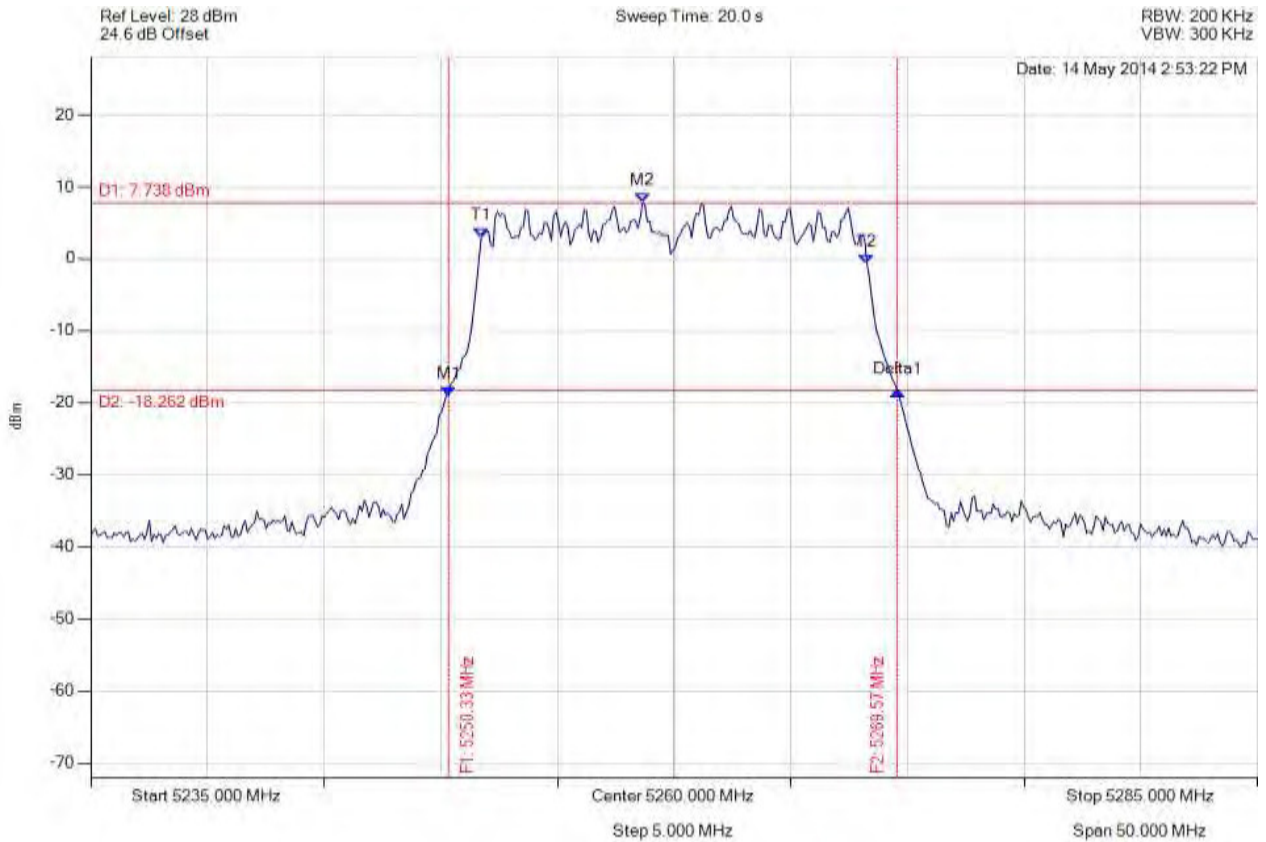

Analyser Setup	Marker : Frequency : Amplitude	Test Results
Detector = MAX PEAK Sweep Count = 0 RF Atten (dB) = 20 Trace Mode = VIEW	M1 : 5250.331 MHz : -19.010 dBm M2 : 5258.647 MHz : 7.738 dBm Delta1 : 19.238 MHz : 0.649 dB T1 : 5251.733 MHz : 2.944 dBm T2 : 5268.267 MHz : -0.653 dBm OBW : 16.533 MHz	Measured 26 dB Bandwidth: 19.238 MHz Measured 99% Bandwidth: 16.533 MHz

[Back to the Matrix](#)

This test report may be reproduced in full only. The document may only be updated by MiCOM Labs personnel. Any changes will be noted in the Document History section of the report.



Title: Aruba Networks APIN0214, APIN0215
To: FCC 47 CFR Part 15.407 & IC RSS-210
Serial #: ARUB179-U8 Rev B
Issue Date: 2nd September 2014
Page: 184 of 330



26 dB & 99% BANDWIDTH

Variant: 802.11a, Channel: 5260.00 MHz, Chain c, Temp: Ambient, Voltage: 12 Vdc

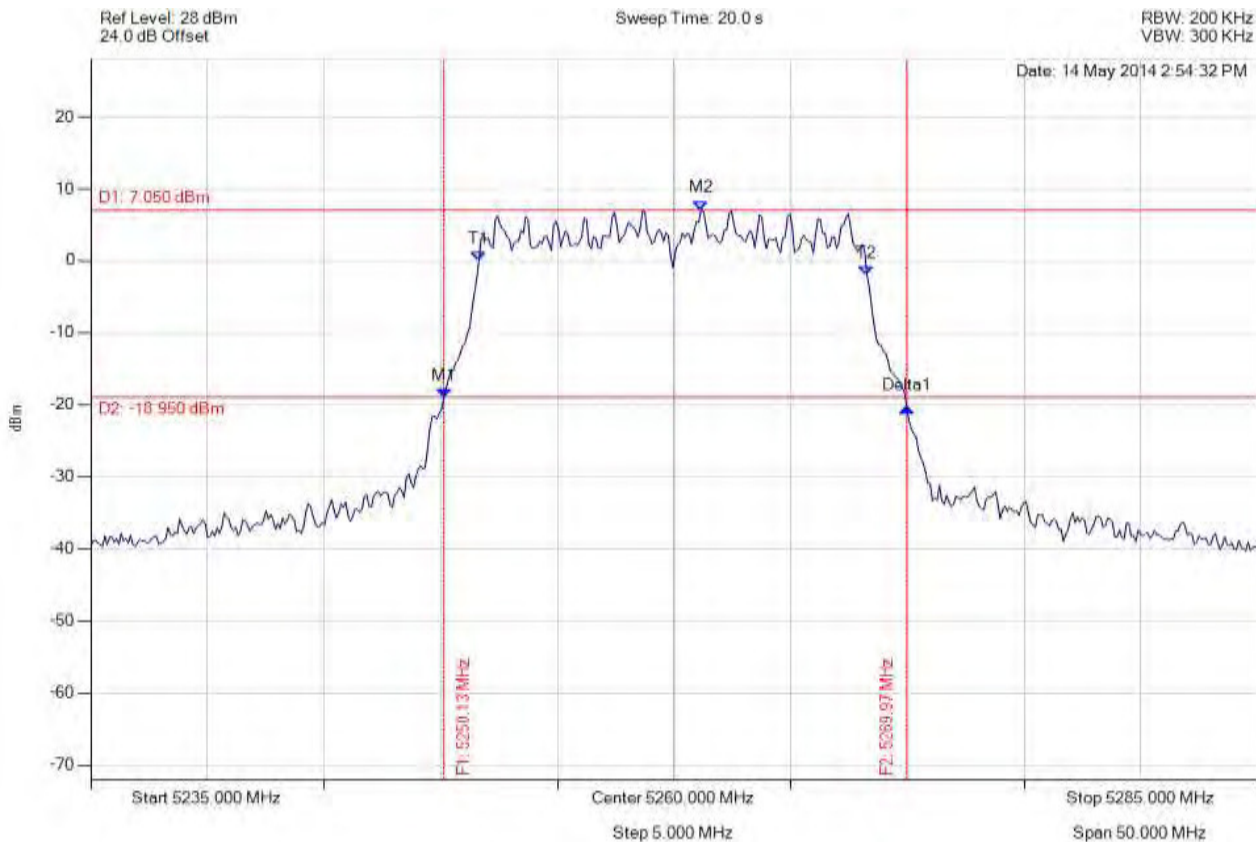

Analyser Setup	Marker : Frequency : Amplitude	Test Results
Detector = MAX PEAK Sweep Count = 0 RF Atten (dB) = 20 Trace Mode = VIEW	M1 : 5250.130 MHz : -19.004 dBm M2 : 5261.152 MHz : 7.050 dBm Delta1 : 19.840 MHz : -1.395 dB T1 : 5251.633 MHz : -0.015 dBm T2 : 5268.267 MHz : -1.975 dBm OBW : 16.633 MHz	Measured 26 dB Bandwidth: 19.840 MHz Measured 99% Bandwidth: 16.633 MHz

[Back to the Matrix](#)

This test report may be reproduced in full only. The document may only be updated by MiCOM Labs personnel. Any changes will be noted in the Document History section of the report.



Title: Aruba Networks APIN0214, APIN0215
To: FCC 47 CFR Part 15.407 & IC RSS-210
Serial #: ARUB179-U8 Rev B
Issue Date: 2nd September 2014
Page: 185 of 330



26 dB & 99% BANDWIDTH

Variant: 802.11a, Channel: 5300.00 MHz, Chain a, Temp: Ambient, Voltage: 12 Vdc

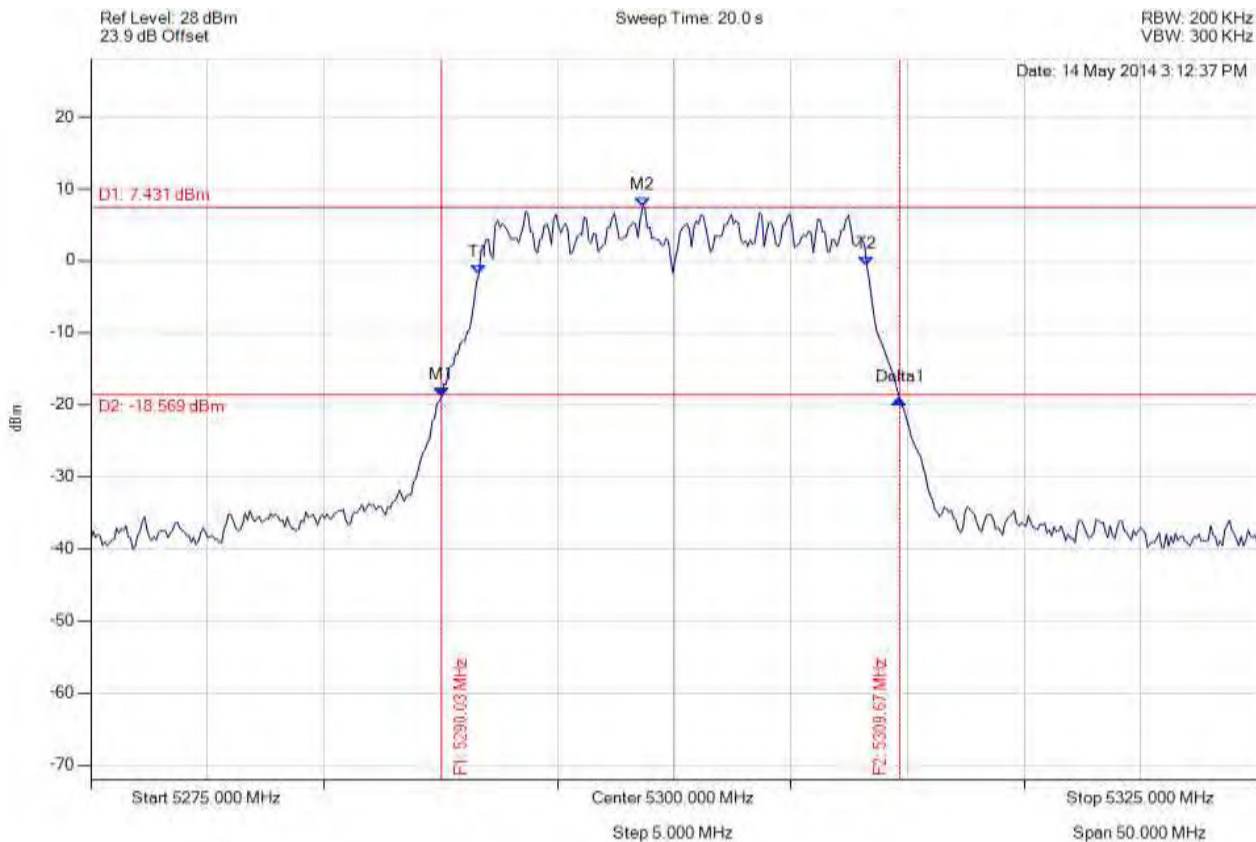

Analyser Setup	Marker : Frequency : Amplitude	Test Results
Detector = MAX PEAK Sweep Count = 0 RF Atten (dB) = 20 Trace Mode = VIEW	M1 : 5290.030 MHz : -18.849 dBm M2 : 5298.647 MHz : 7.431 dBm Delta1 : 19.639 MHz : -0.311 dB T1 : 5291.633 MHz : -1.829 dBm T2 : 5308.267 MHz : -0.773 dBm OBW : 16.633 MHz	Measured 26 dB Bandwidth : 19.639 MHz Measured 99% Bandwidth : 16.633 MHz

[Back to the Matrix](#)

This test report may be reproduced in full only. The document may only be updated by MiCOM Labs personnel. Any changes will be noted in the Document History section of the report.



26 dB & 99% BANDWIDTH

Variant: 802.11a, Channel: 5300.00 MHz, Chain b, Temp: Ambient, Voltage: 12 Vdc

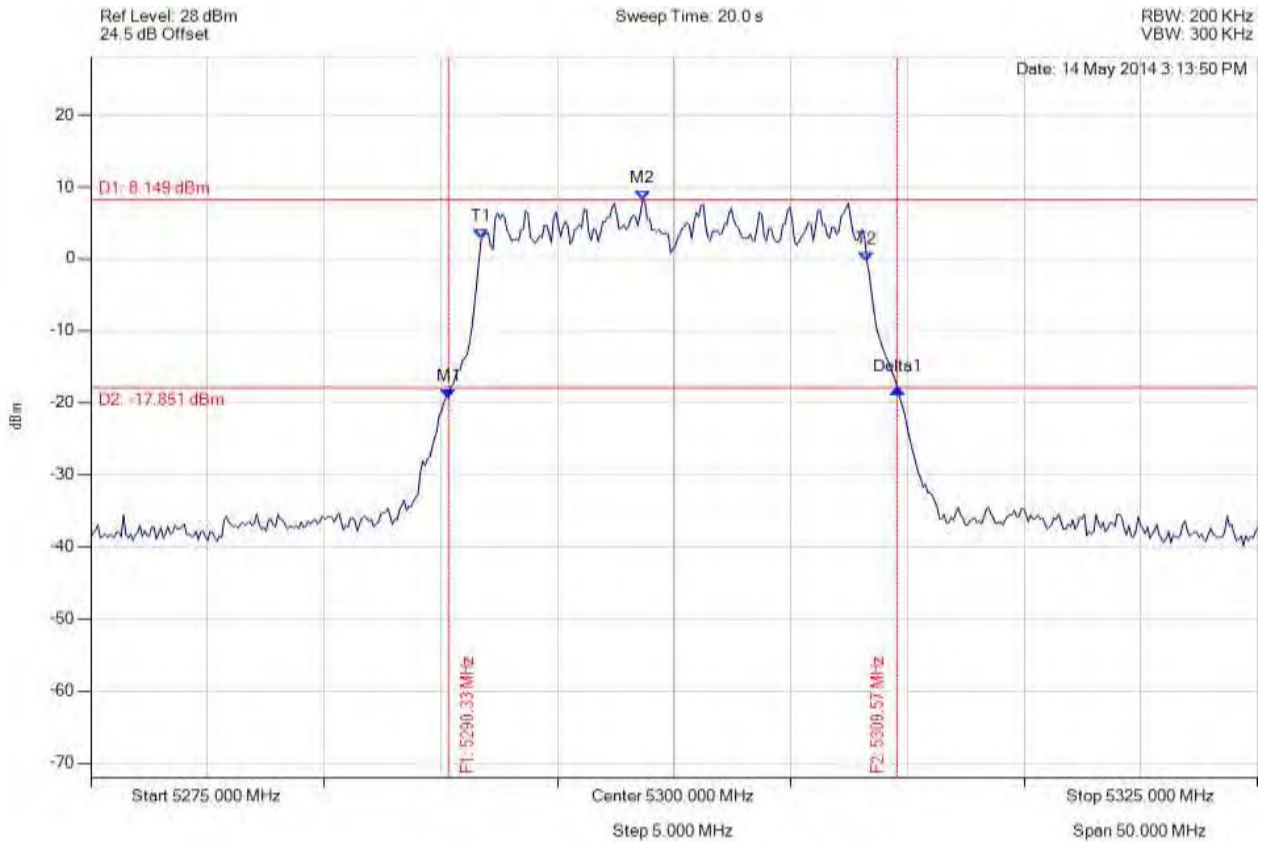

Analyser Setup	Marker : Frequency : Amplitude	Test Results
Detector = MAX PEAK Sweep Count = 0 RF Atten (dB) = 20 Trace Mode = VIEW	M1 : 5290.331 MHz : -19.325 dBm M2 : 5298.647 MHz : 8.149 dBm Delta1 : 19.238 MHz : 1.322 dB T1 : 5291.733 MHz : 2.794 dBm T2 : 5308.267 MHz : -0.306 dBm OBW : 16.533 MHz	Measured 26 dB Bandwidth: 19.238 MHz Measured 99% Bandwidth: 16.533 MHz

[Back to the Matrix](#)

This test report may be reproduced in full only. The document may only be updated by MiCOM Labs personnel. Any changes will be noted in the Document History section of the report.



Title: Aruba Networks APIN0214, APIN0215
To: FCC 47 CFR Part 15.407 & IC RSS-210
Serial #: ARUB179-U8 Rev B
Issue Date: 2nd September 2014
Page: 187 of 330



26 dB & 99% BANDWIDTH

Variant: 802.11a, Channel: 5300.00 MHz, Chain c, Temp: Ambient, Voltage: 12 Vdc

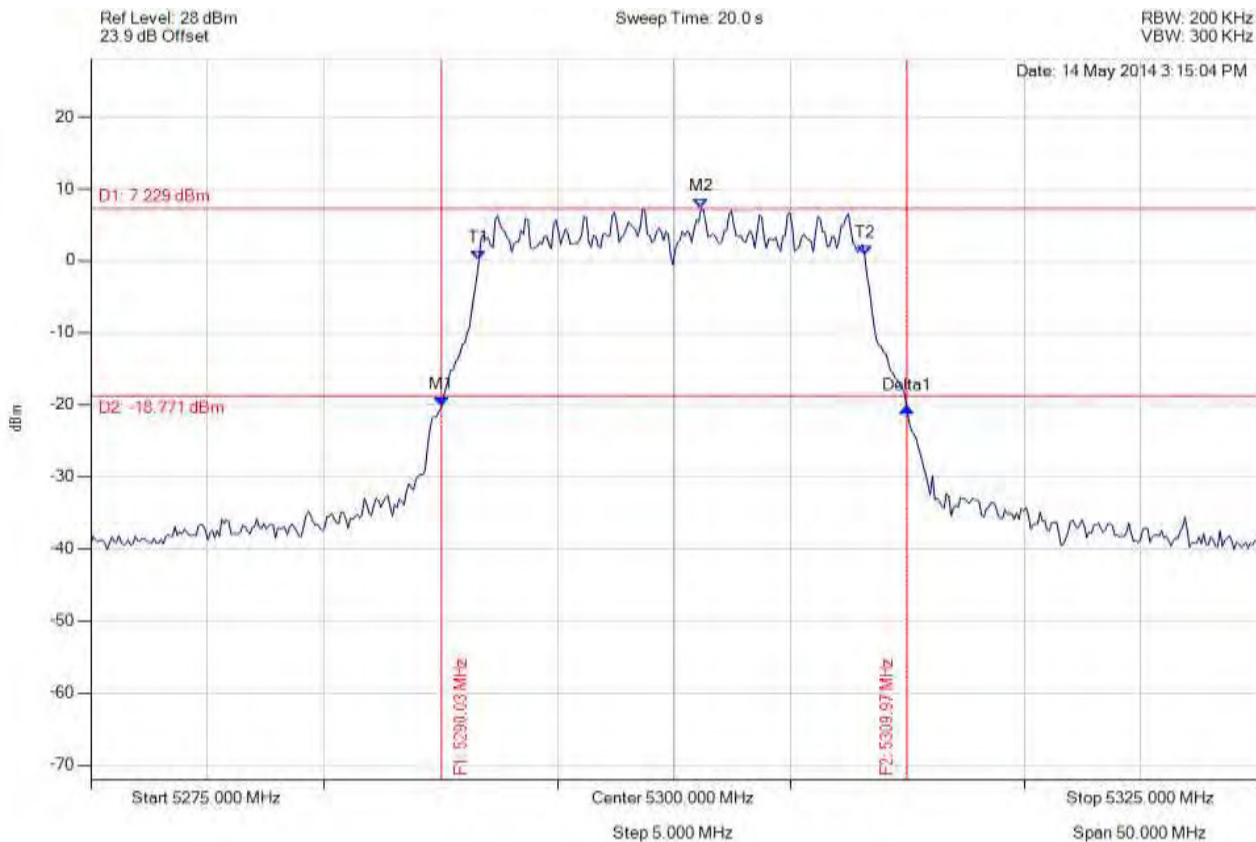

Analyser Setup	Marker : Frequency : Amplitude	Test Results
Detector = MAX PEAK Sweep Count = 0 RF Atten (dB) = 20 Trace Mode = VIEW	M1 : 5290.030 MHz : -20.277 dBm M2 : 5301.152 MHz : 7.229 dBm Delta1 : 19.940 MHz : -0.150 dB T1 : 5291.633 MHz : 0.089 dBm T2 : 5308.166 MHz : 0.795 dBm OBW : 16.533 MHz	Measured 26 dB Bandwidth: 19.940 MHz Measured 99% Bandwidth: 16.533 MHz

[Back to the Matrix](#)

This test report may be reproduced in full only. The document may only be updated by MiCOM Labs personnel. Any changes will be noted in the Document History section of the report.



Title: Aruba Networks APIN0214, APIN0215
To: FCC 47 CFR Part 15.407 & IC RSS-210
Serial #: ARUB179-U8 Rev B
Issue Date: 2nd September 2014
Page: 188 of 330



26 dB & 99% BANDWIDTH

Variant: 802.11a, Channel: 5320.00 MHz, Chain a, Temp: Ambient, Voltage: 12 Vdc

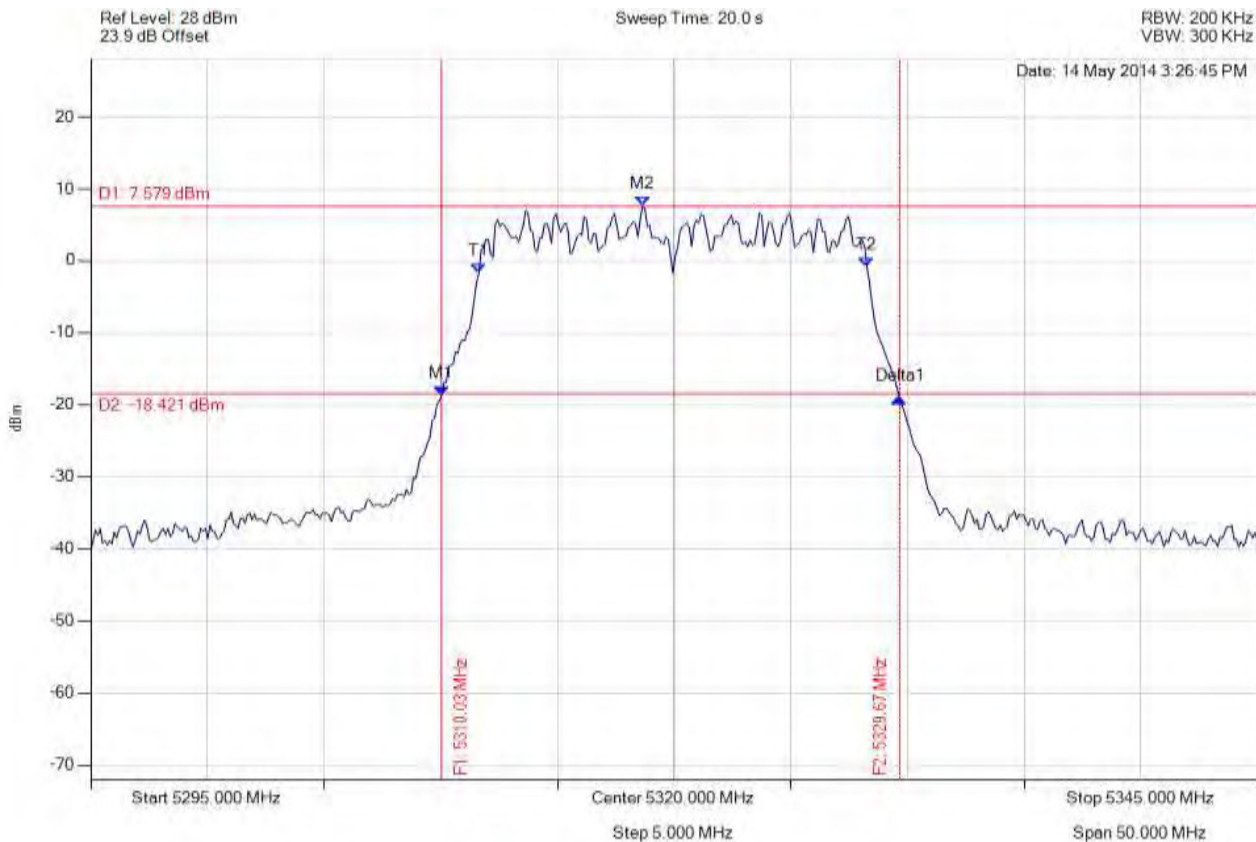

Analyser Setup	Marker : Frequency : Amplitude	Test Results
Detector = MAX PEAK Sweep Count = 0 RF Atten (dB) = 20 Trace Mode = VIEW	M1 : 5310.030 MHz : -18.681 dBm M2 : 5318.647 MHz : 7.579 dBm Delta1 : 19.639 MHz : -0.441 dB T1 : 5311.633 MHz : -1.752 dBm T2 : 5328.267 MHz : -0.922 dBm OBW : 16.633 MHz	Measured 26 dB Bandwidth: 19.639 MHz Measured 99% Bandwidth: 16.633 MHz

[Back to the Matrix](#)

This test report may be reproduced in full only. The document may only be updated by MiCOM Labs personnel. Any changes will be noted in the Document History section of the report.



Title: Aruba Networks APIN0214, APIN0215
To: FCC 47 CFR Part 15.407 & IC RSS-210
Serial #: ARUB179-U8 Rev B
Issue Date: 2nd September 2014
Page: 189 of 330



26 dB & 99% BANDWIDTH

Variant: 802.11a, Channel: 5320.00 MHz, Chain b, Temp: Ambient, Voltage: 12 Vdc

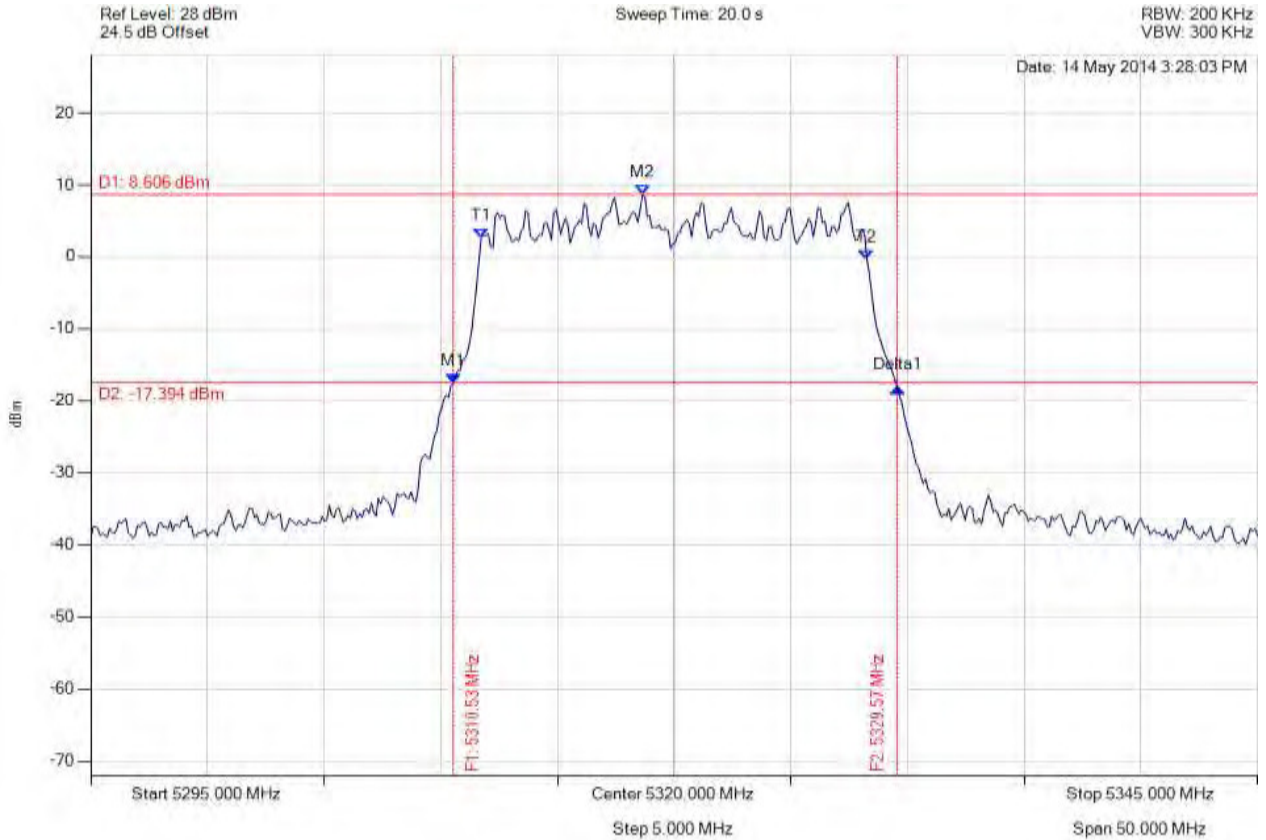

Analyser Setup	Marker : Frequency : Amplitude	Test Results
Detector = MAX PEAK Sweep Count = 0 RF Atten (dB) = 20 Trace Mode = VIEW	M1 : 5310.531 MHz : -17.515 dBm M2 : 5318.647 MHz : 8.606 dBm Delta1 : 19.038 MHz : -0.614 dB T1 : 5311.733 MHz : 2.694 dBm T2 : 5328.267 MHz : -0.375 dBm OBW : 16.533 MHz	Measured 26 dB Bandwidth : 19.038 MHz Measured 99% Bandwidth : 16.533 MHz

[Back to the Matrix](#)

This test report may be reproduced in full only. The document may only be updated by MiCOM Labs personnel. Any changes will be noted in the Document History section of the report.



Title: Aruba Networks APIN0214, APIN0215
To: FCC 47 CFR Part 15.407 & IC RSS-210
Serial #: ARUB179-U8 Rev B
Issue Date: 2nd September 2014
Page: 190 of 330



26 dB & 99% BANDWIDTH

Variant: 802.11a, Channel: 5320.00 MHz, Chain c, Temp: Ambient, Voltage: 12 Vdc

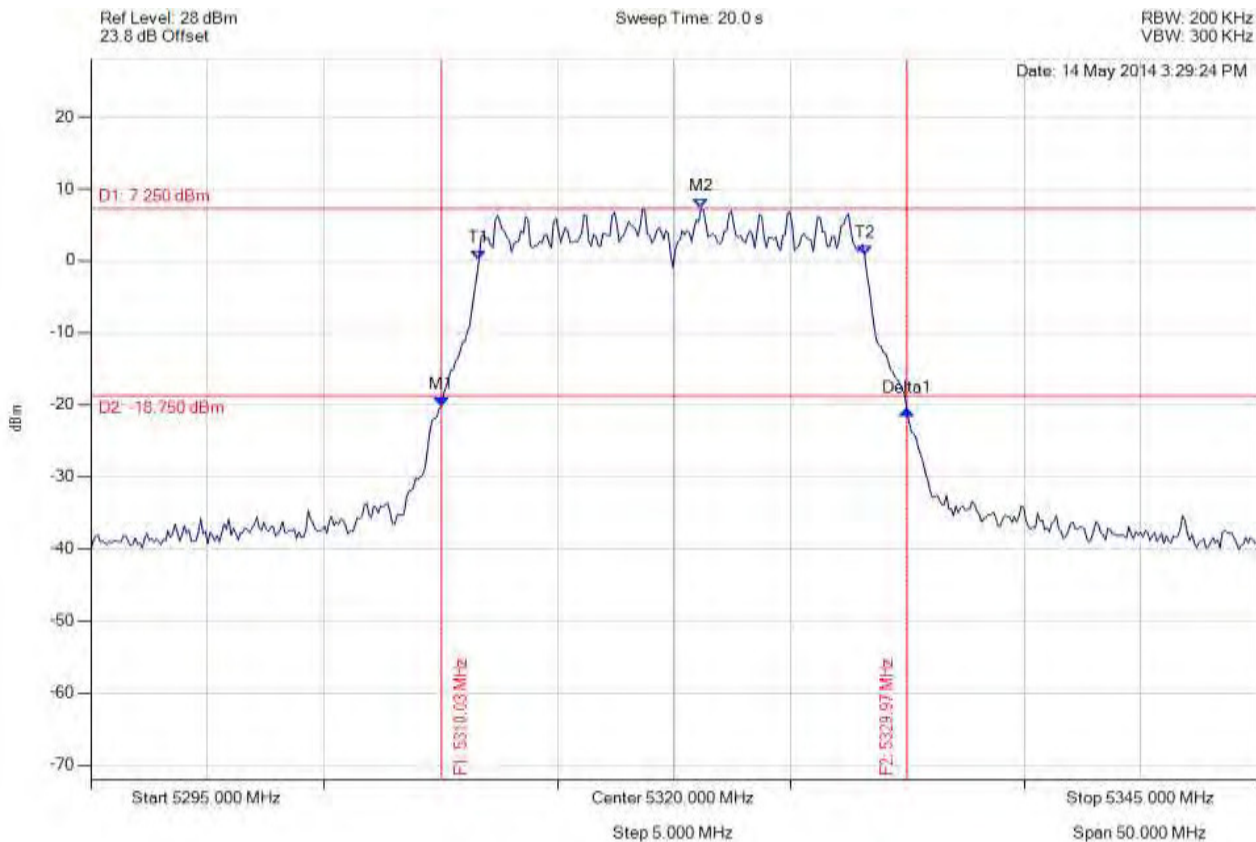

Analyser Setup	Marker : Frequency : Amplitude	Test Results
Detector = MAX PEAK Sweep Count = 0 RF Atten (dB) = 20 Trace Mode = VIEW	M1 : 5310.030 MHz : -20.145 dBm M2 : 5321.152 MHz : 7.250 dBm Delta1 : 19.940 MHz : -0.525 dB T1 : 5311.633 MHz : 0.101 dBm T2 : 5328.166 MHz : 0.780 dBm OBW : 16.533 MHz	Measured 26 dB Bandwidth: 19.940 MHz Measured 99% Bandwidth: 16.533 MHz

[Back to the Matrix](#)

This test report may be reproduced in full only. The document may only be updated by MiCOM Labs personnel. Any changes will be noted in the Document History section of the report.



Title: Aruba Networks APIN0214, APIN0215
To: FCC 47 CFR Part 15.407 & IC RSS-210
Serial #: ARUB179-U8 Rev B
Issue Date: 2nd September 2014
Page: 191 of 330



26 dB & 99% BANDWIDTH

Variant: 802.11ac-80, Channel: 5290.00 MHz, Chain a, Temp: Ambient, Voltage: 12 Vdc

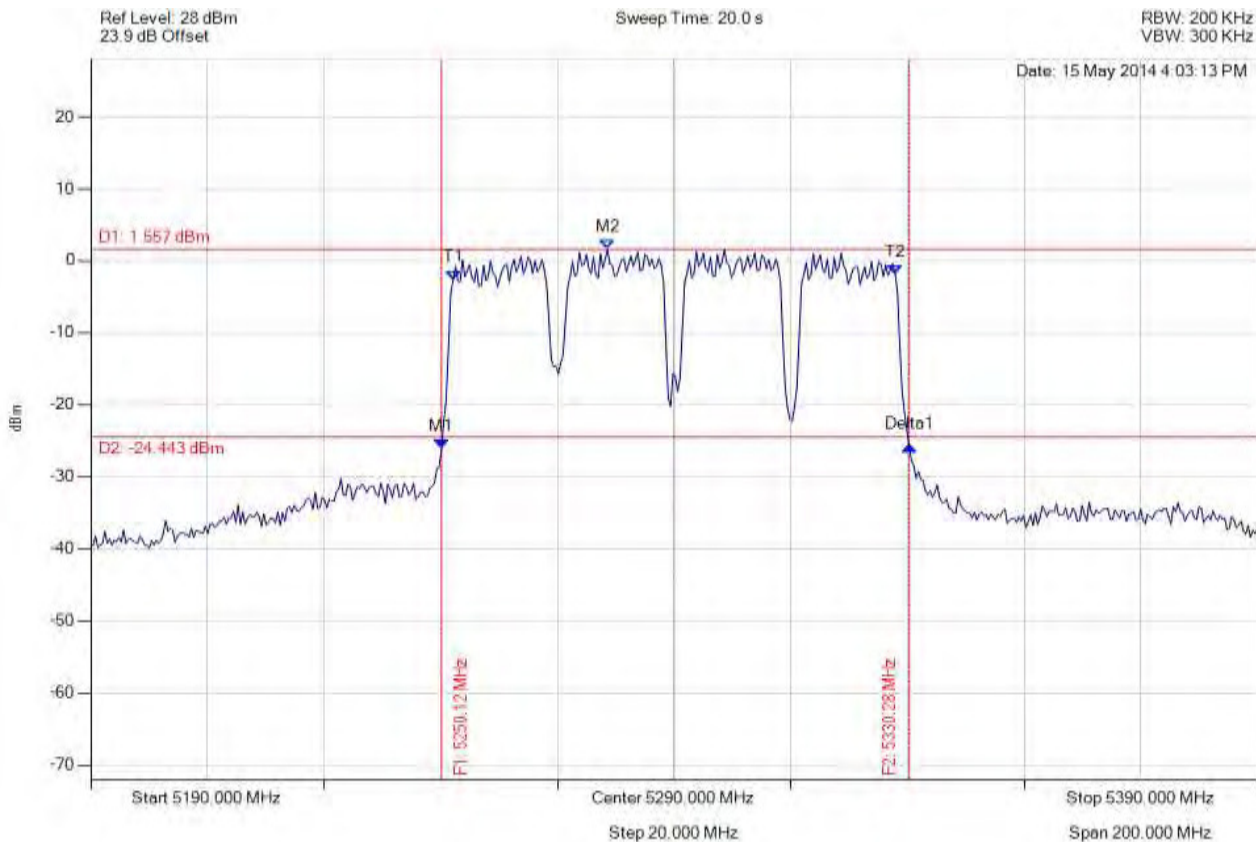

Analyser Setup	Marker : Frequency : Amplitude	Test Results
Detector = MAX PEAK Sweep Count = 0 RF Atten (dB) = 20 Trace Mode = VIEW	M1 : 5250.120 MHz : -26.010 dBm M2 : 5278.577 MHz : 1.557 dBm Delta1 : 80.160 MHz : 0.232 dB T1 : 5252.124 MHz : -2.626 dBm T2 : 5327.876 MHz : -1.807 dBm OBW : 75.752 MHz	Measured 26 dB Bandwidth: 80.160 MHz Measured 99% Bandwidth: 75.752 MHz

[Back to the Matrix](#)

This test report may be reproduced in full only. The document may only be updated by MiCOM Labs personnel. Any changes will be noted in the Document History section of the report.



Title: Aruba Networks APIN0214, APIN0215
To: FCC 47 CFR Part 15.407 & IC RSS-210
Serial #: ARUB179-U8 Rev B
Issue Date: 2nd September 2014
Page: 192 of 330



26 dB & 99% BANDWIDTH

Variant: 802.11ac-80, Channel: 5290.00 MHz, Chain b, Temp: Ambient, Voltage: 12 Vdc

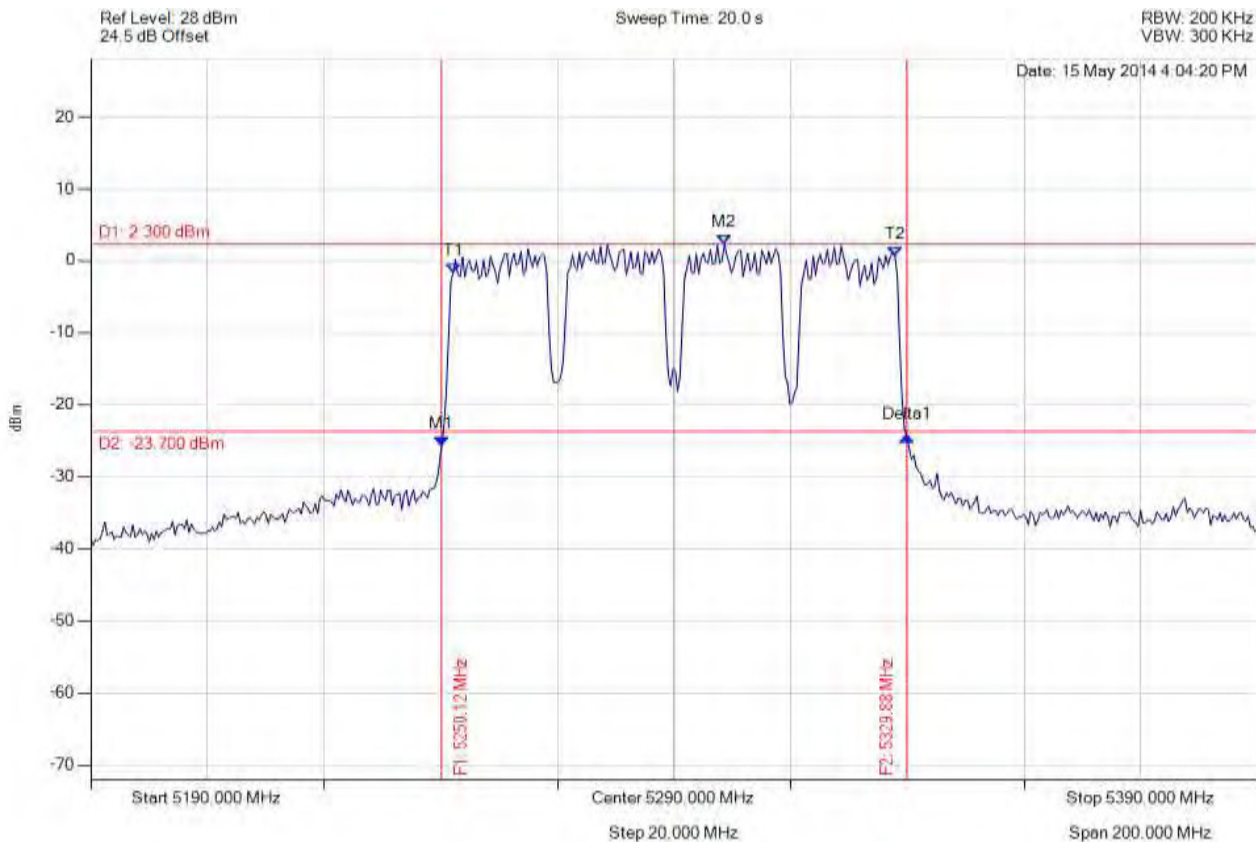

Analyser Setup	Marker : Frequency : Amplitude	Test Results
Detector = MAX PEAK Sweep Count = 0 RF Atten (dB) = 20 Trace Mode = VIEW	M1 : 5250.120 MHz : -25.780 dBm M2 : 5298.617 MHz : 2.300 dBm Delta1 : 79.760 MHz : 1.373 dB T1 : 5252.124 MHz : -1.674 dBm T2 : 5327.876 MHz : 0.612 dBm OBW : 75.752 MHz	Measured 26 dB Bandwidth: 79.760 MHz Measured 99% Bandwidth: 75.752 MHz

[Back to the Matrix](#)

This test report may be reproduced in full only. The document may only be updated by MiCOM Labs personnel. Any changes will be noted in the Document History section of the report.



Title: Aruba Networks APIN0214, APIN0215
To: FCC 47 CFR Part 15.407 & IC RSS-210
Serial #: ARUB179-U8 Rev B
Issue Date: 2nd September 2014
Page: 193 of 330



26 dB & 99% BANDWIDTH

Variant: 802.11ac-80, Channel: 5290.00 MHz, Chain c, Temp: Ambient, Voltage: 12 Vdc

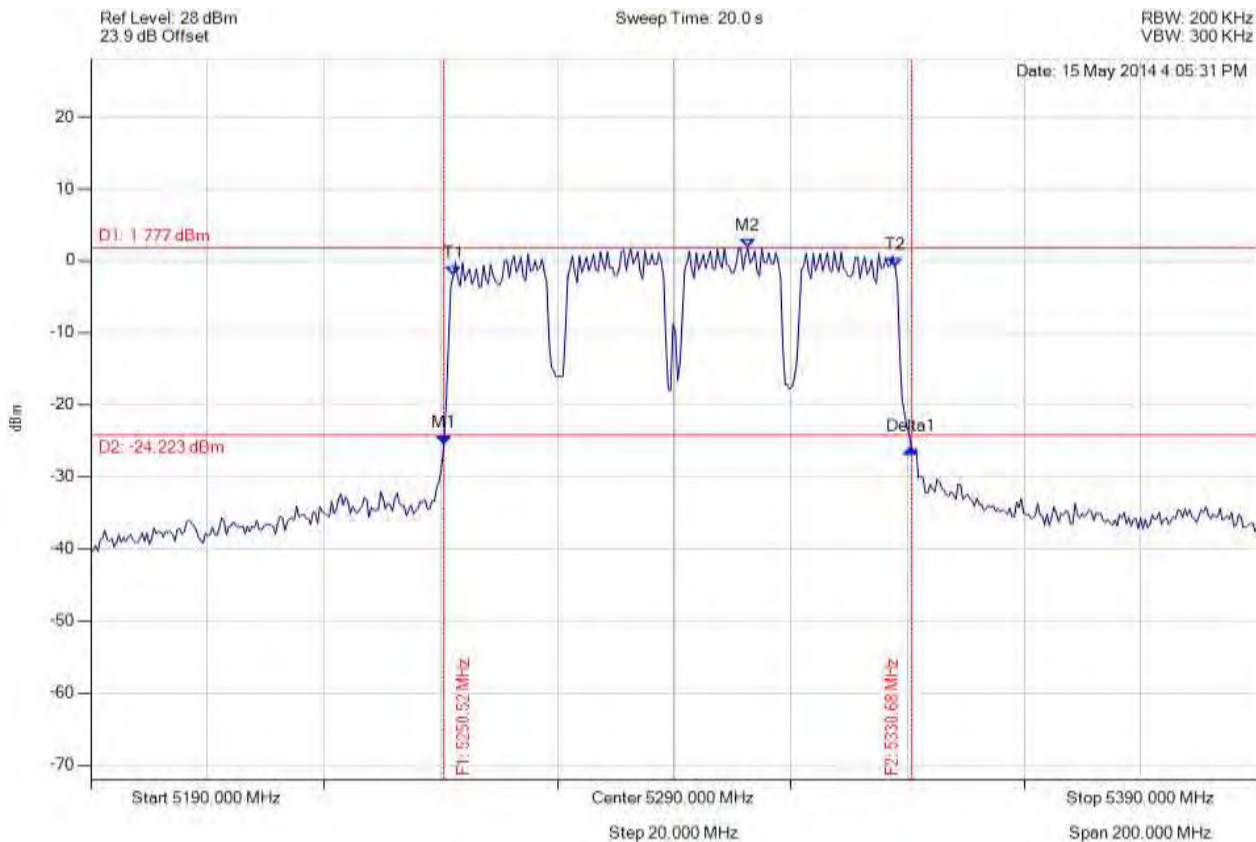

Analyser Setup	Marker : Frequency : Amplitude	Test Results
Detector = MAX PEAK Sweep Count = 0 RF Atten (dB) = 20 Trace Mode = VIEW	M1 : 5250.521 MHz : -25.502 dBm M2 : 5302.625 MHz : 1.777 dBm Delta1 : 80.160 MHz : -0.559 dB T1 : 5252.124 MHz : -2.022 dBm T2 : 5327.876 MHz : -0.808 dBm OBW : 75.752 MHz	Measured 26 dB Bandwidth: 80.160 MHz Measured 99% Bandwidth: 75.752 MHz

[Back to the Matrix](#)

This test report may be reproduced in full only. The document may only be updated by MiCOM Labs personnel. Any changes will be noted in the Document History section of the report.



Title: Aruba Networks APIN0214, APIN0215
To: FCC 47 CFR Part 15.407 & IC RSS-210
Serial #: ARUB179-U8 Rev B
Issue Date: 2nd September 2014
Page: 194 of 330



26 dB & 99% BANDWIDTH

Variant: 802.11n HT-20, Channel: 5260.00 MHz, Chain a, Temp: Ambient, Voltage: 12 Vdc

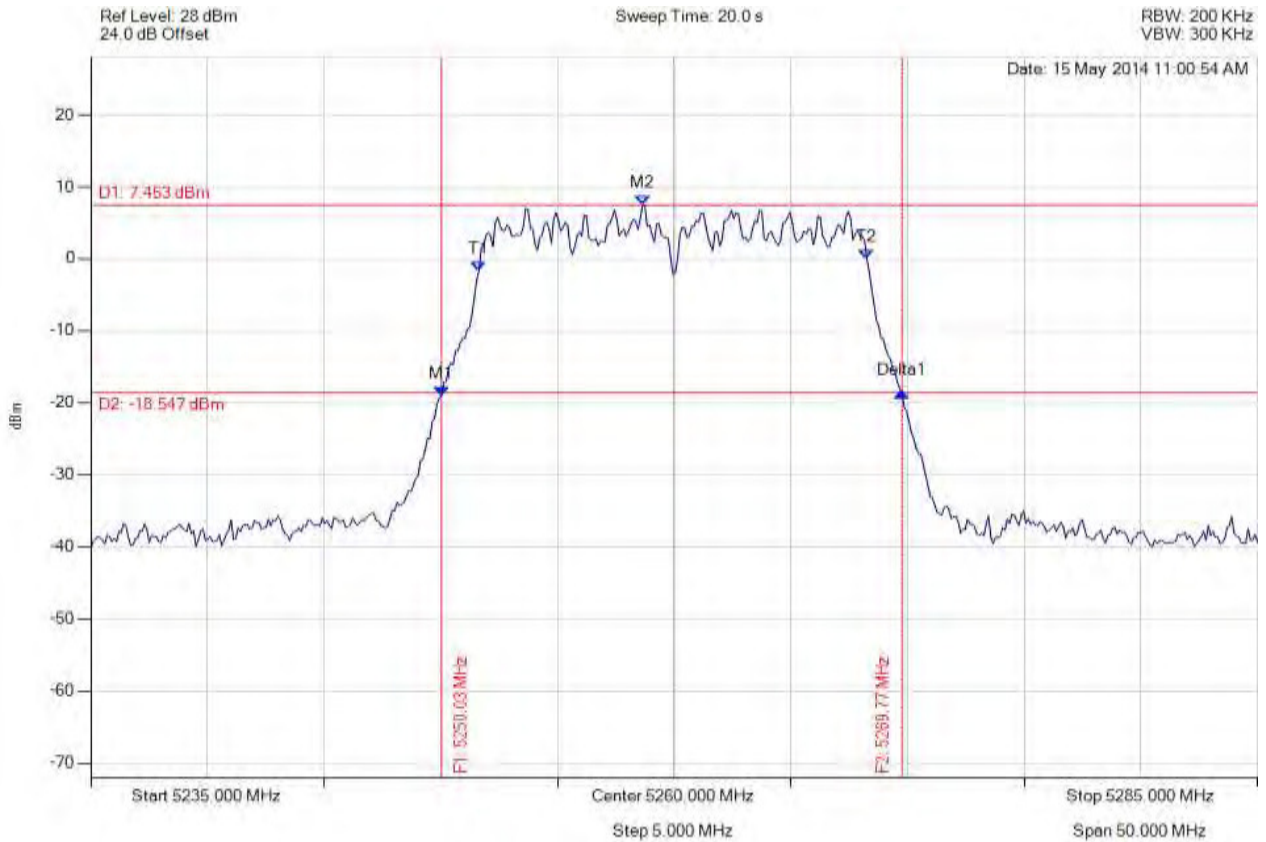

Analyser Setup	Marker : Frequency : Amplitude	Test Results
Detector = MAX PEAK Sweep Count = 0 RF Atten (dB) = 20 Trace Mode = VIEW	M1 : 5250.030 MHz : -19.026 dBm M2 : 5258.647 MHz : 7.453 dBm Delta1 : 19.739 MHz : 0.407 dB T1 : 5251.633 MHz : -1.691 dBm T2 : 5268.267 MHz : -0.100 dBm OBW : 16.633 MHz	Measured 26 dB Bandwidth: 19.739 MHz Measured 99% Bandwidth: 16.633 MHz

[Back to the Matrix](#)

This test report may be reproduced in full only. The document may only be updated by MiCOM Labs personnel. Any changes will be noted in the Document History section of the report.



Title: Aruba Networks APIN0214, APIN0215
To: FCC 47 CFR Part 15.407 & IC RSS-210
Serial #: ARUB179-U8 Rev B
Issue Date: 2nd September 2014
Page: 195 of 330



26 dB & 99% BANDWIDTH

Variant: 802.11n HT-20, Channel: 5260.00 MHz, Chain b, Temp: Ambient, Voltage: 12 Vdc

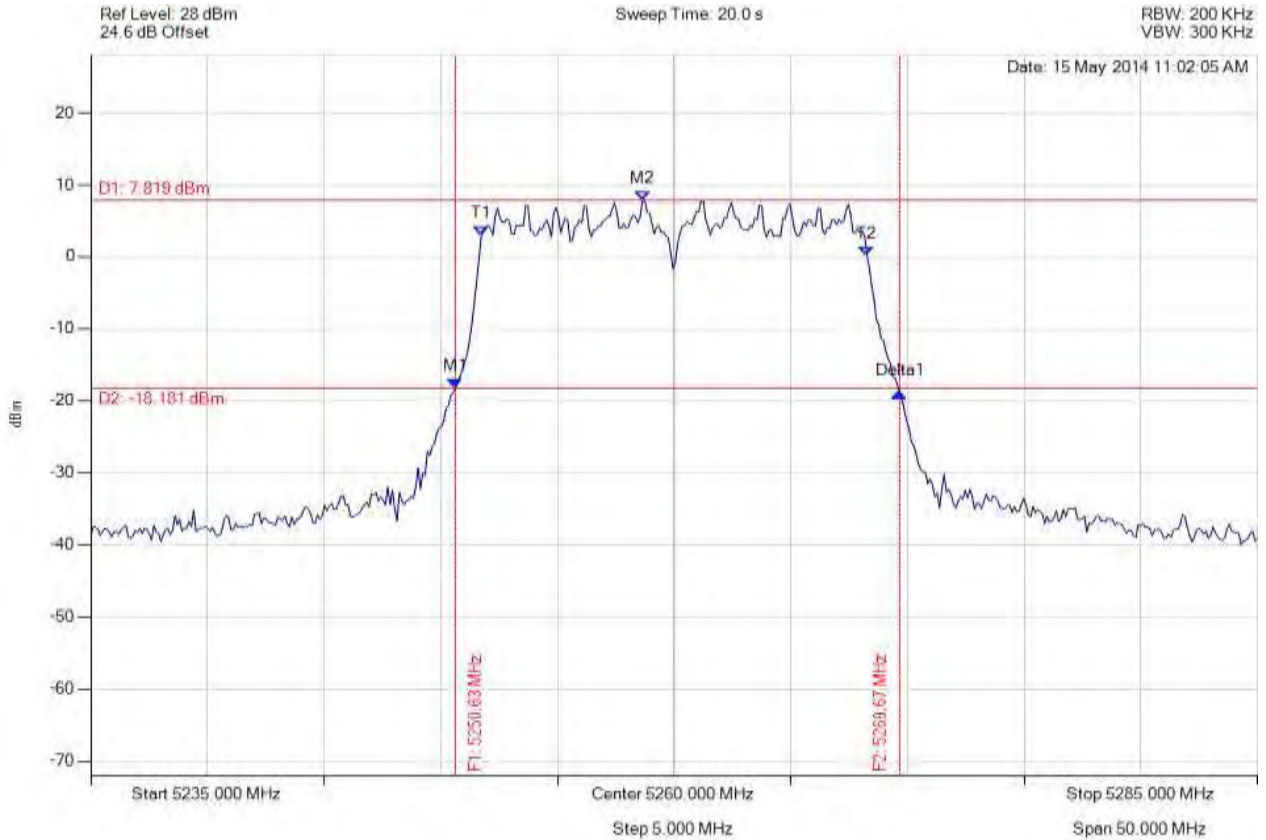

Analyser Setup	Marker : Frequency : Amplitude	Test Results
Detector = MAX PEAK Sweep Count = 0 RF Atten (dB) = 20 Trace Mode = VIEW	M1 : 5250.631 MHz : -18.258 dBm M2 : 5258.647 MHz : 7.819 dBm Delta1 : 19.038 MHz : -0.665 dB T1 : 5251.733 MHz : 2.950 dBm T2 : 5268.267 MHz : 0.158 dBm OBW : 16.533 MHz	Measured 26 dB Bandwidth: 19.038 MHz Measured 99% Bandwidth: 16.533 MHz

[Back to the Matrix](#)

This test report may be reproduced in full only. The document may only be updated by MiCOM Labs personnel. Any changes will be noted in the Document History section of the report.



Title: Aruba Networks APIN0214, APIN0215
To: FCC 47 CFR Part 15.407 & IC RSS-210
Serial #: ARUB179-U8 Rev B
Issue Date: 2nd September 2014
Page: 196 of 330



26 dB & 99% BANDWIDTH

Variant: 802.11n HT-20, Channel: 5260.00 MHz, Chain c, Temp: Ambient, Voltage: 12 Vdc

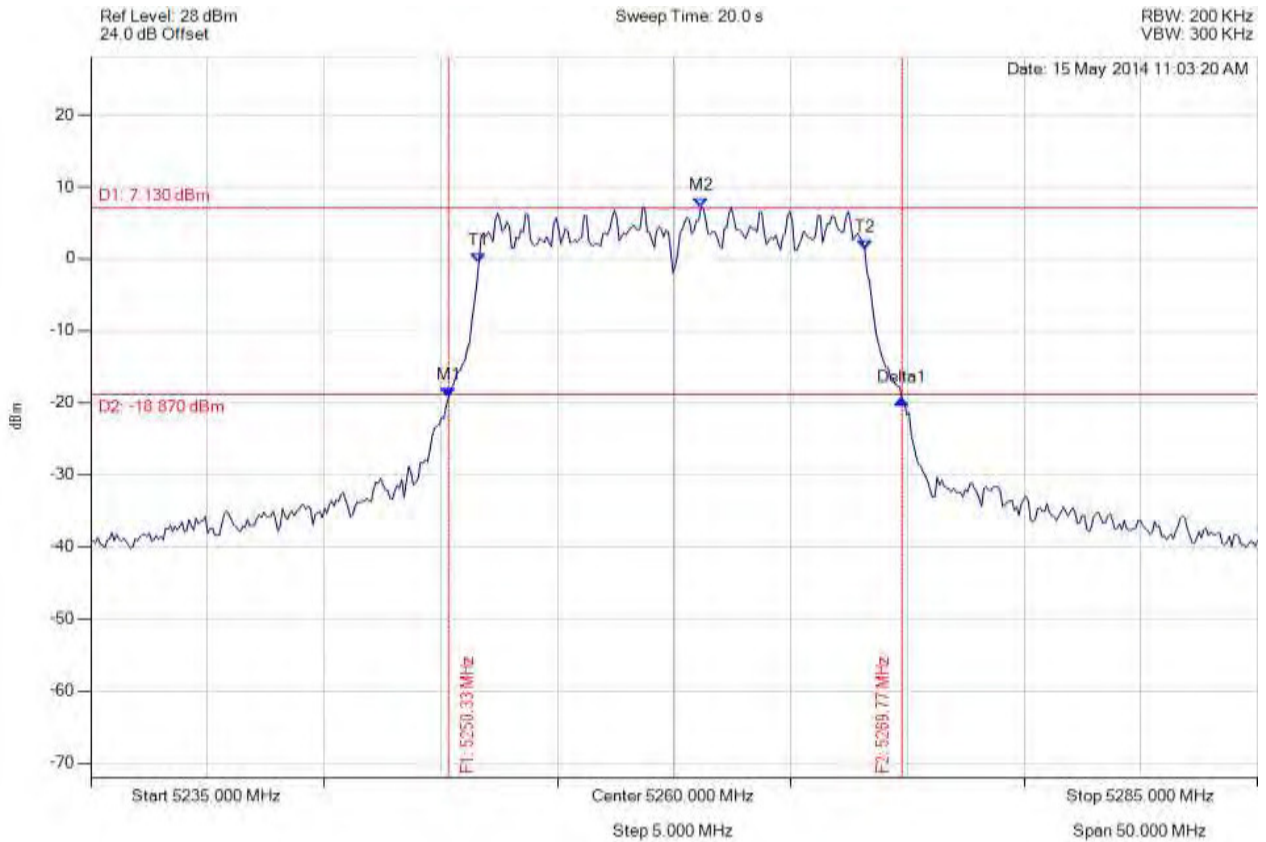

Analyser Setup	Marker : Frequency : Amplitude	Test Results
Detector = MAX PEAK Sweep Count = 0 RF Atten (dB) = 20 Trace Mode = VIEW	M1 : 5250.331 MHz : -19.289 dBm M2 : 5261.152 MHz : 7.130 dBm Delta1 : 19.439 MHz : -0.256 dB T1 : 5251.633 MHz : -0.474 dBm T2 : 5268.166 MHz : 1.368 dBm OBW : 16.533 MHz	Measured 26 dB Bandwidth: 19.439 MHz Measured 99% Bandwidth: 16.533 MHz

[Back to the Matrix](#)

This test report may be reproduced in full only. The document may only be updated by MiCOM Labs personnel. Any changes will be noted in the Document History section of the report.



Title: Aruba Networks APIN0214, APIN0215
To: FCC 47 CFR Part 15.407 & IC RSS-210
Serial #: ARUB179-U8 Rev B
Issue Date: 2nd September 2014
Page: 197 of 330



26 dB & 99% BANDWIDTH

Variant: 802.11n HT-20, Channel: 5300.00 MHz, Chain a, Temp: Ambient, Voltage: 12 Vdc

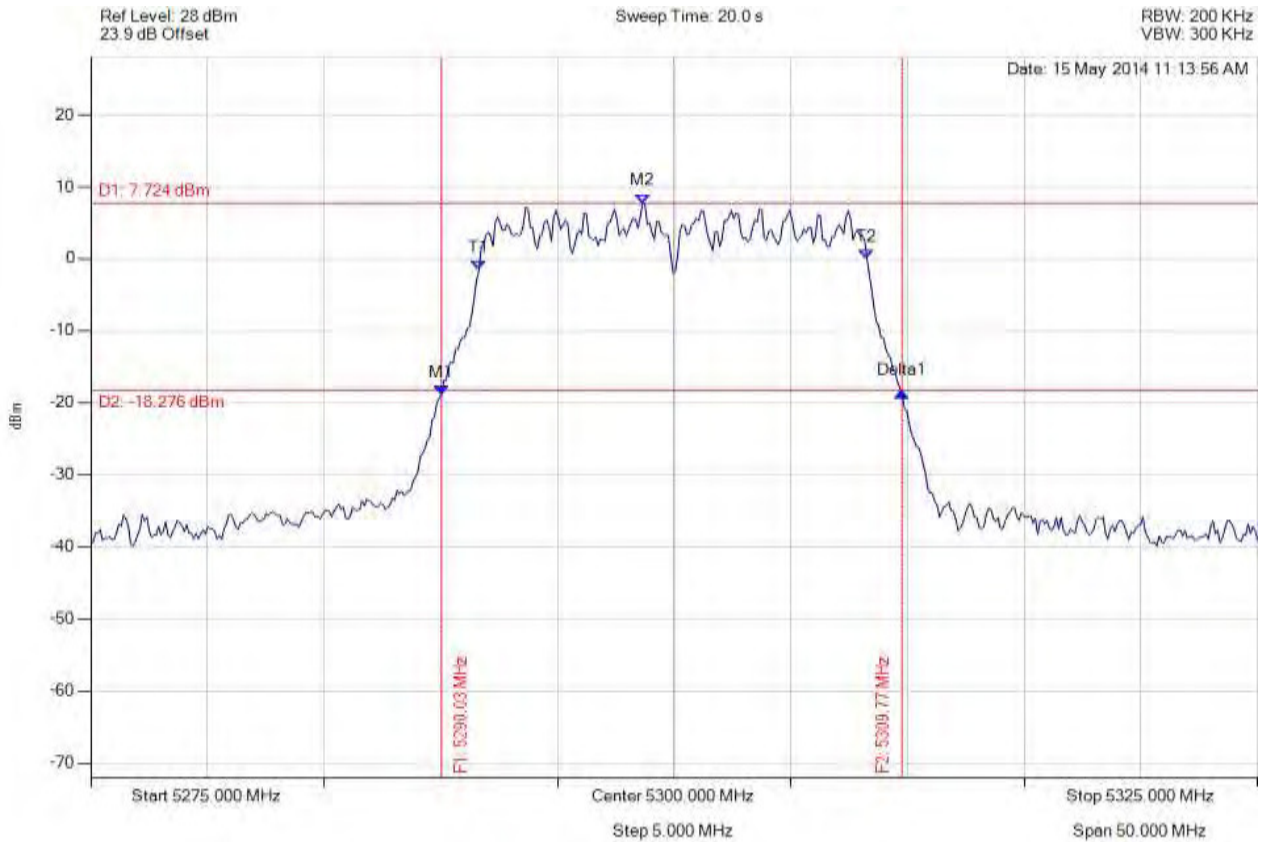

Analyser Setup	Marker : Frequency : Amplitude	Test Results
Detector = MAX PEAK Sweep Count = 0 RF Atten (dB) = 20 Trace Mode = VIEW	M1 : 5290.030 MHz : -18.823 dBm M2 : 5298.647 MHz : 7.724 dBm Delta1 : 19.739 MHz : 0.260 dB T1 : 5291.633 MHz : -1.601 dBm T2 : 5308.267 MHz : -0.068 dBm OBW : 16.633 MHz	Measured 26 dB Bandwidth: 19.739 MHz Measured 99% Bandwidth: 16.633 MHz

[Back to the Matrix](#)

This test report may be reproduced in full only. The document may only be updated by MiCOM Labs personnel. Any changes will be noted in the Document History section of the report.



Title: Aruba Networks APIN0214, APIN0215
To: FCC 47 CFR Part 15.407 & IC RSS-210
Serial #: ARUB179-U8 Rev B
Issue Date: 2nd September 2014
Page: 198 of 330



26 dB & 99% BANDWIDTH

Variant: 802.11n HT-20, Channel: 5300.00 MHz, Chain b, Temp: Ambient, Voltage: 12 Vdc

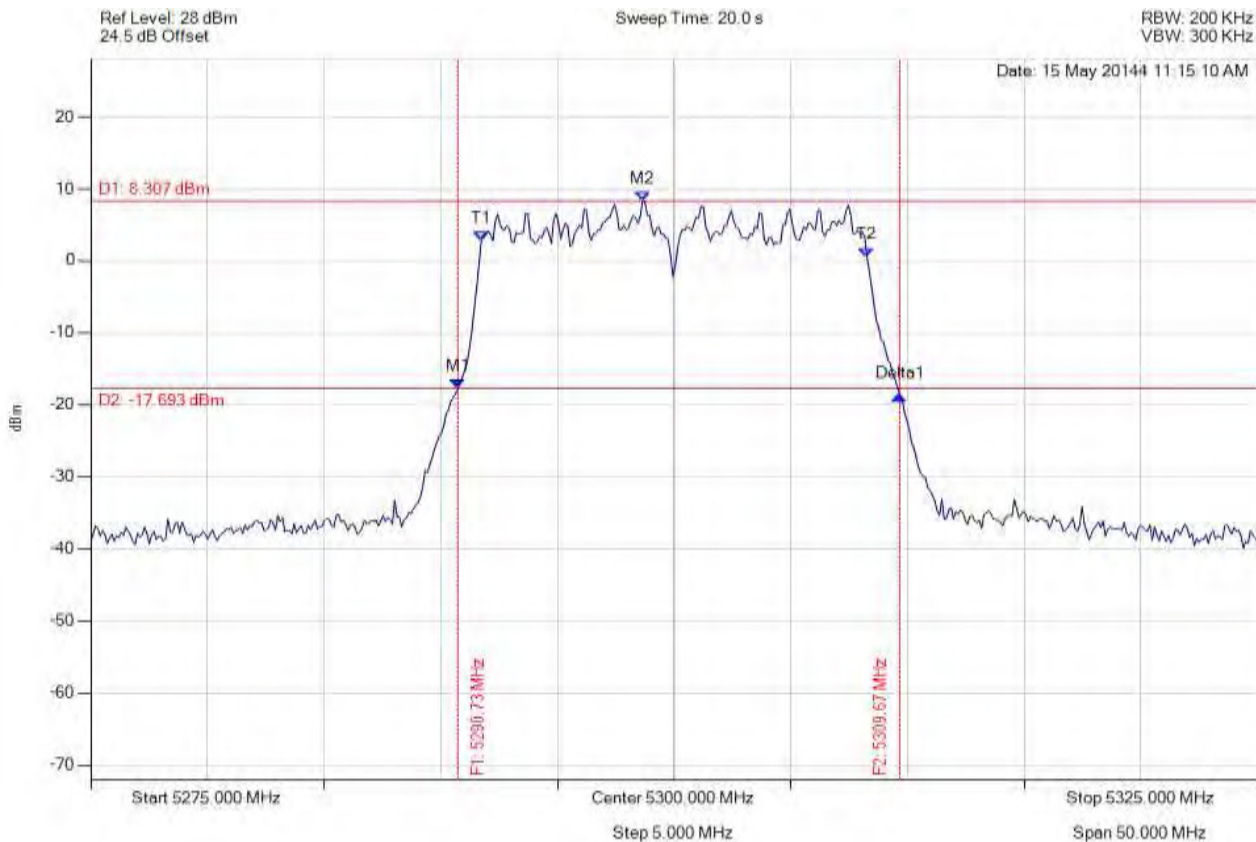

Analyser Setup	Marker : Frequency : Amplitude	Test Results
Detector = MAX PEAK Sweep Count = 0 RF Atten (dB) = 20 Trace Mode = VIEW	M1 : 5290.731 MHz : -17.731 dBm M2 : 5298.647 MHz : 8.307 dBm Delta1 : 18.938 MHz : -0.950 dB T1 : 5291.733 MHz : 2.794 dBm T2 : 5308.267 MHz : 0.551 dBm OBW : 16.533 MHz	Measured 26 dB Bandwidth: 18.938 MHz Measured 99% Bandwidth: 16.533 MHz

[Back to the Matrix](#)

This test report may be reproduced in full only. The document may only be updated by MiCOM Labs personnel. Any changes will be noted in the Document History section of the report.



Title: Aruba Networks APIN0214, APIN0215
To: FCC 47 CFR Part 15.407 & IC RSS-210
Serial #: ARUB179-U8 Rev B
Issue Date: 2nd September 2014
Page: 199 of 330



26 dB & 99% BANDWIDTH

Variant: 802.11n HT-20, Channel: 5300.00 MHz, Chain c, Temp: Ambient, Voltage: 12 Vdc

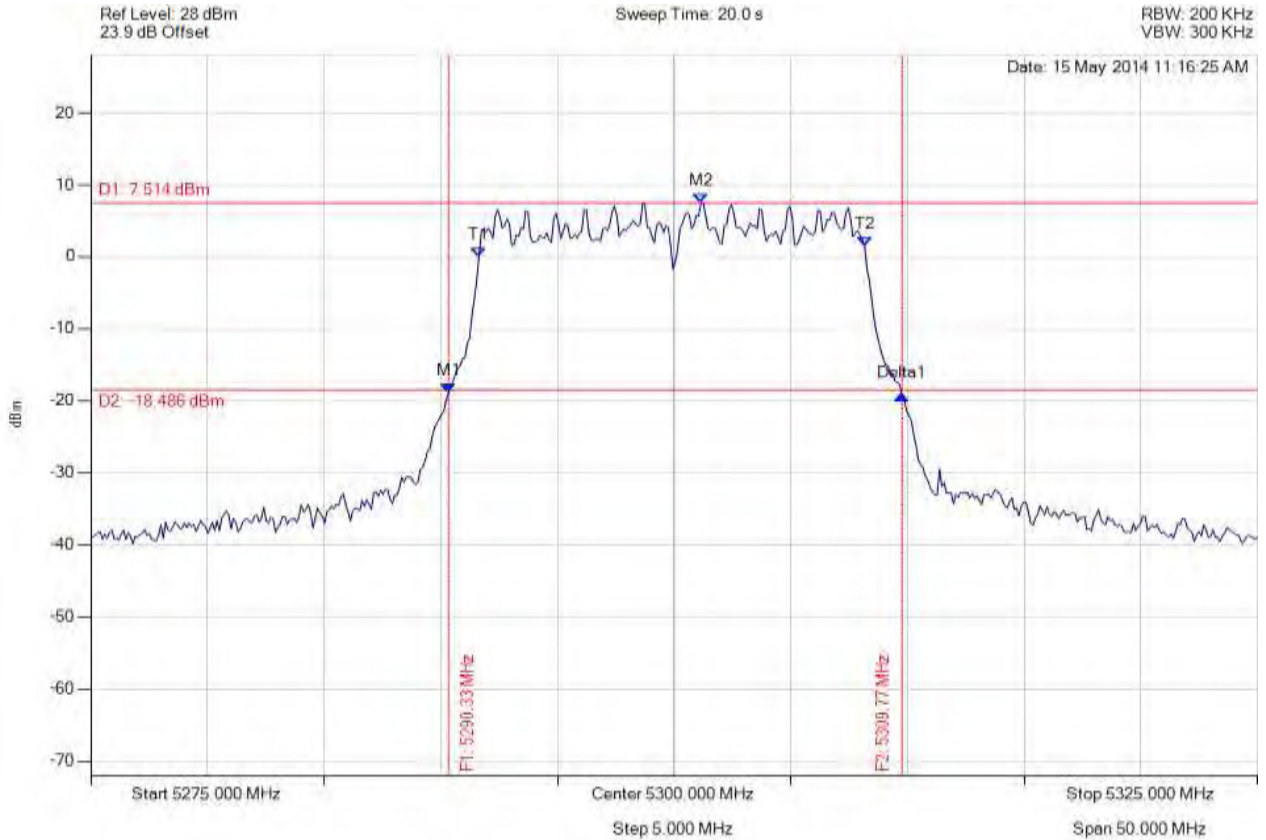

Analyser Setup	Marker : Frequency : Amplitude	Test Results
Detector = MAX PEAK Sweep Count = 0 RF Atten (dB) = 20 Trace Mode = VIEW	M1 : 5290.331 MHz : -18.894 dBm M2 : 5301.152 MHz : 7.514 dBm Delta1 : 19.439 MHz : -0.325 dB T1 : 5291.633 MHz : -0.045 dBm T2 : 5308.166 MHz : 1.433 dBm OBW : 16.533 MHz	Measured 26 dB Bandwidth: 19.439 MHz Measured 99% Bandwidth: 16.533 MHz

[Back to the Matrix](#)

This test report may be reproduced in full only. The document may only be updated by MiCOM Labs personnel. Any changes will be noted in the Document History section of the report.



Title: Aruba Networks APIN0214, APIN0215
To: FCC 47 CFR Part 15.407 & IC RSS-210
Serial #: ARUB179-U8 Rev B
Issue Date: 2nd September 2014
Page: 200 of 330



26 dB & 99% BANDWIDTH

Variant: 802.11n HT-20, Channel: 5320.00 MHz, Chain a, Temp: Ambient, Voltage: 12 Vdc

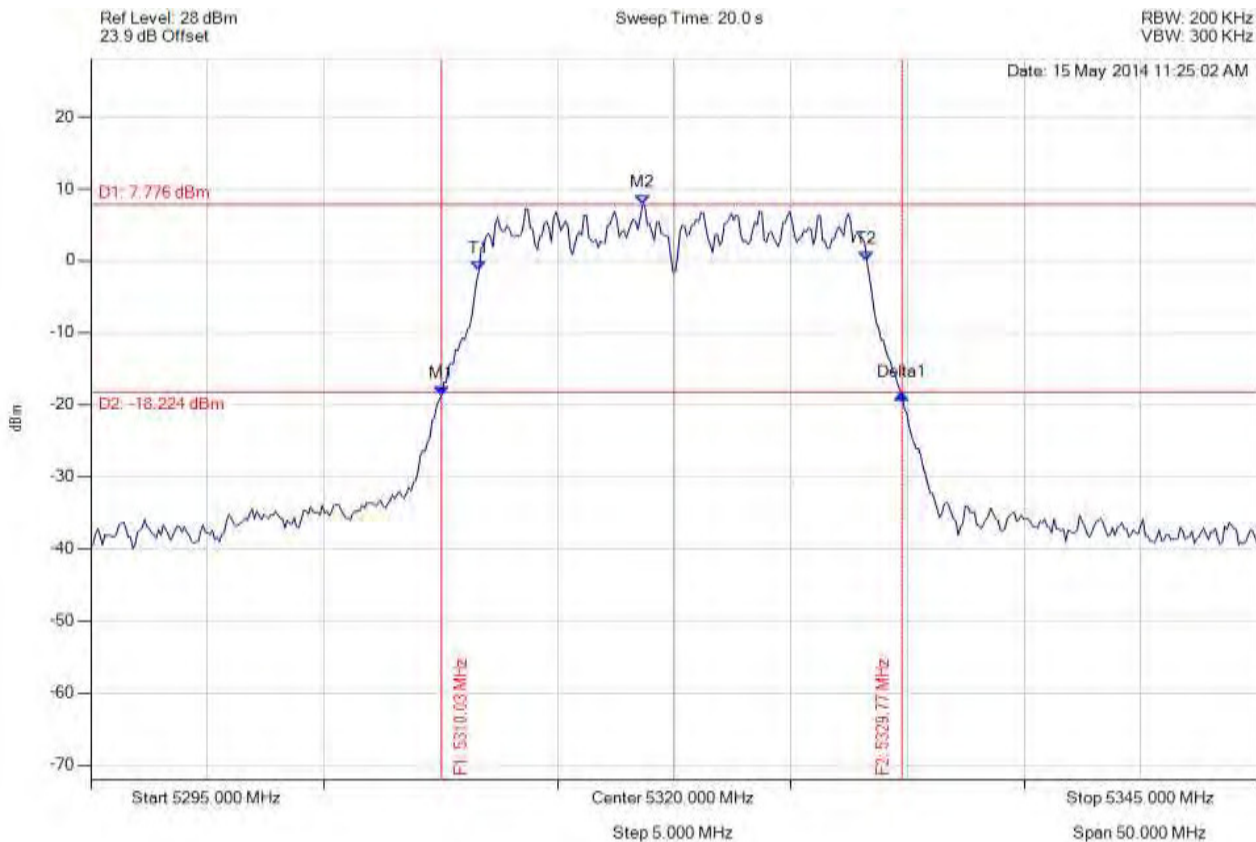

Analyser Setup	Marker : Frequency : Amplitude	Test Results
Detector = MAX PEAK Sweep Count = 0 RF Atten (dB) = 20 Trace Mode = VIEW	M1 : 5310.030 MHz : -18.654 dBm M2 : 5318.647 MHz : 7.776 dBm Delta1 : 19.739 MHz : 0.130 dB T1 : 5311.633 MHz : -1.430 dBm T2 : 5328.267 MHz : -0.106 dBm OBW : 16.633 MHz	Measured 26 dB Bandwidth: 19.739 MHz Measured 99% Bandwidth: 16.633 MHz

[Back to the Matrix](#)

This test report may be reproduced in full only. The document may only be updated by MiCOM Labs personnel. Any changes will be noted in the Document History section of the report.



Title: Aruba Networks APIN0214, APIN0215
To: FCC 47 CFR Part 15.407 & IC RSS-210
Serial #: ARUB179-U8 Rev B
Issue Date: 2nd September 2014
Page: 201 of 330



26 dB & 99% BANDWIDTH

Variant: 802.11n HT-20, Channel: 5320.00 MHz, Chain b, Temp: Ambient, Voltage: 12 Vdc

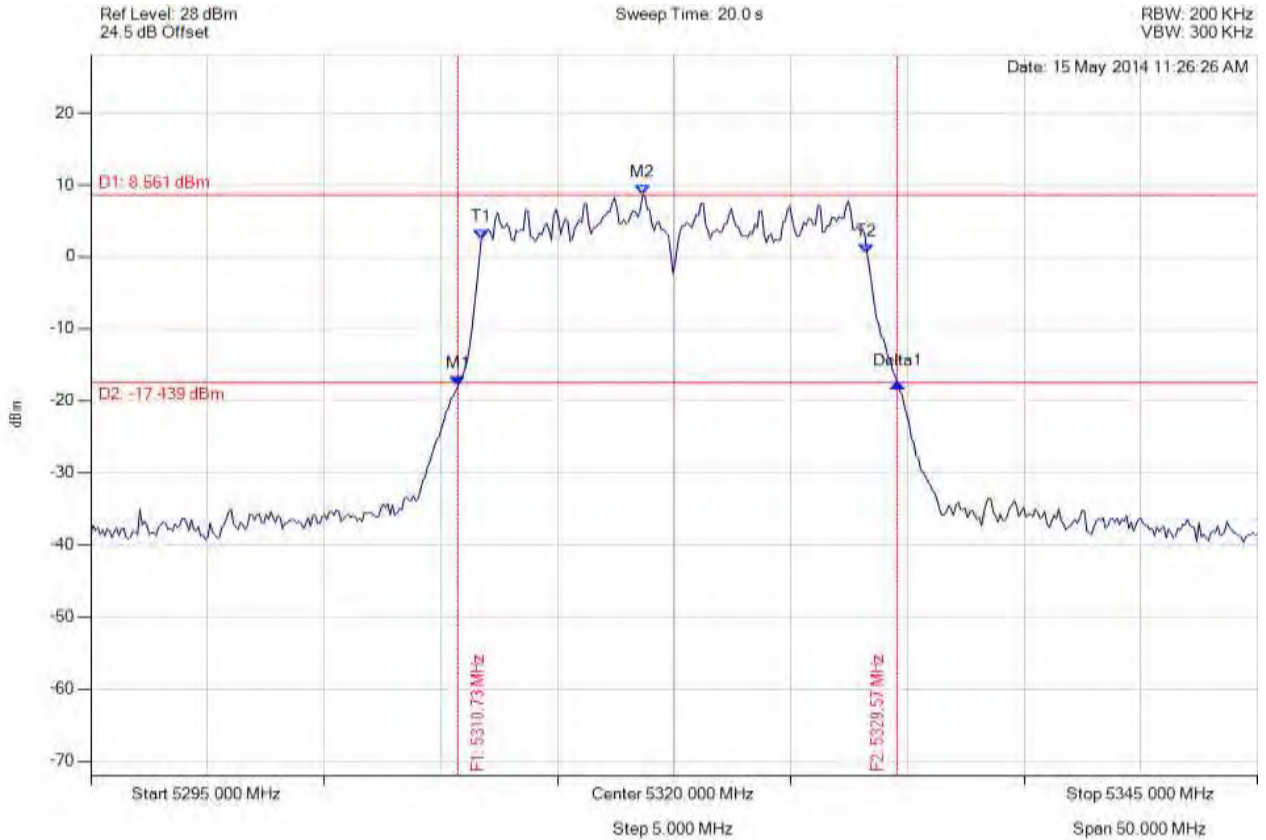

Analyser Setup	Marker : Frequency : Amplitude	Test Results
Detector = MAX PEAK Sweep Count = 0 RF Atten (dB) = 20 Trace Mode = VIEW	M1 : 5310.731 MHz : -17.946 dBm M2 : 5318.647 MHz : 8.561 dBm Delta1 : 18.838 MHz : 0.462 dB T1 : 5311.733 MHz : 2.452 dBm T2 : 5328.267 MHz : 0.534 dBm OBW : 16.533 MHz	Measured 26 dB Bandwidth: 18.838 MHz Measured 99% Bandwidth: 16.533 MHz

[Back to the Matrix](#)

This test report may be reproduced in full only. The document may only be updated by MiCOM Labs personnel. Any changes will be noted in the Document History section of the report.



Title: Aruba Networks APIN0214, APIN0215
To: FCC 47 CFR Part 15.407 & IC RSS-210
Serial #: ARUB179-U8 Rev B
Issue Date: 2nd September 2014
Page: 202 of 330



26 dB & 99% BANDWIDTH

Variant: 802.11n HT-20, Channel: 5320.00 MHz, Chain c, Temp: Ambient, Voltage: 12 Vdc

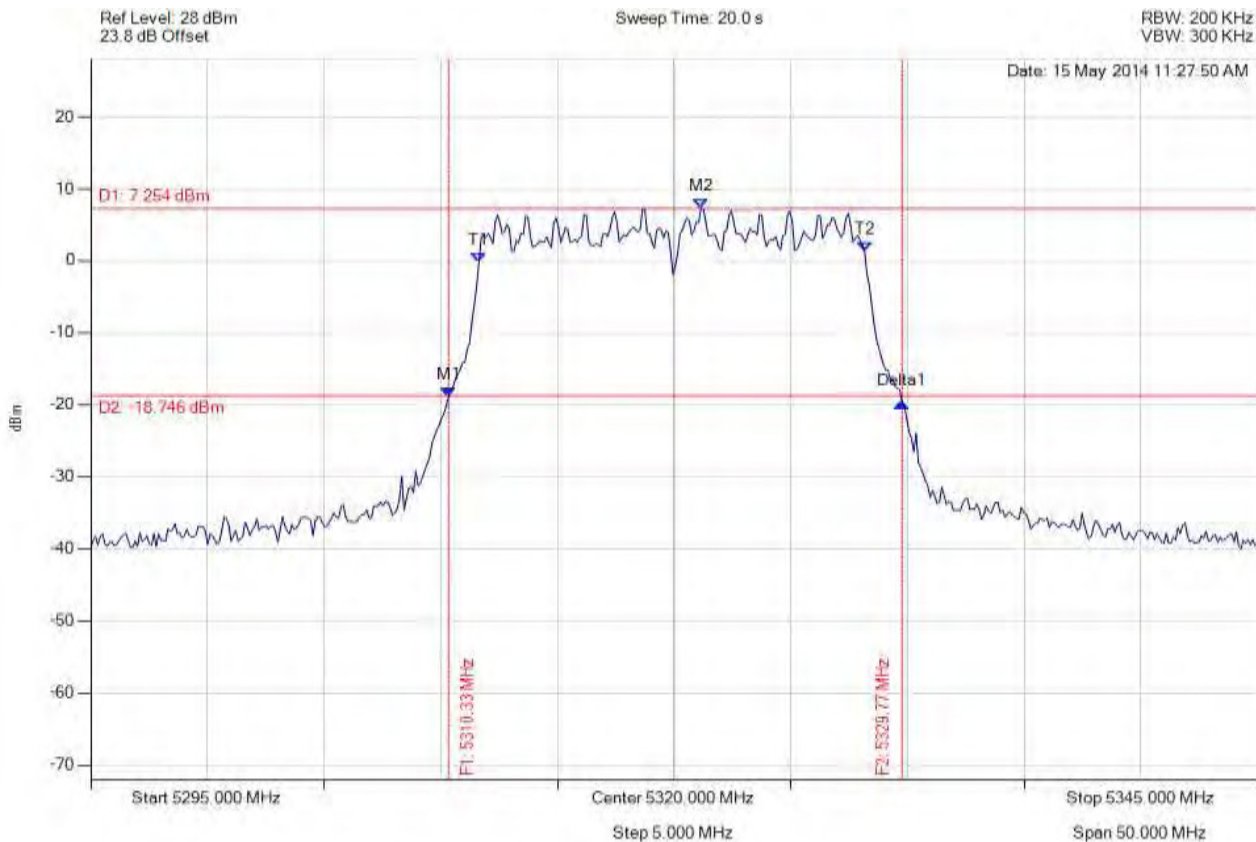

Analyser Setup	Marker : Frequency : Amplitude	Test Results
Detector = MAX PEAK Sweep Count = 0 RF Atten (dB) = 20 Trace Mode = VIEW	M1 : 5310.331 MHz : -18.914 dBm M2 : 5321.152 MHz : 7.254 dBm Delta1 : 19.439 MHz : -0.809 dB T1 : 5311.633 MHz : -0.261 dBm T2 : 5328.166 MHz : 1.283 dBm OBW : 16.533 MHz	Measured 26 dB Bandwidth : 19.439 MHz Measured 99% Bandwidth : 16.533 MHz

[Back to the Matrix](#)

This test report may be reproduced in full only. The document may only be updated by MiCOM Labs personnel. Any changes will be noted in the Document History section of the report.



Title: Aruba Networks APIN0214, APIN0215
To: FCC 47 CFR Part 15.407 & IC RSS-210
Serial #: ARUB179-U8 Rev B
Issue Date: 2nd September 2014
Page: 203 of 330



26 dB & 99% BANDWIDTH

Variant: 802.11n HT-40, Channel: 5270.00 MHz, Chain a, Temp: Ambient, Voltage: 12 Vdc

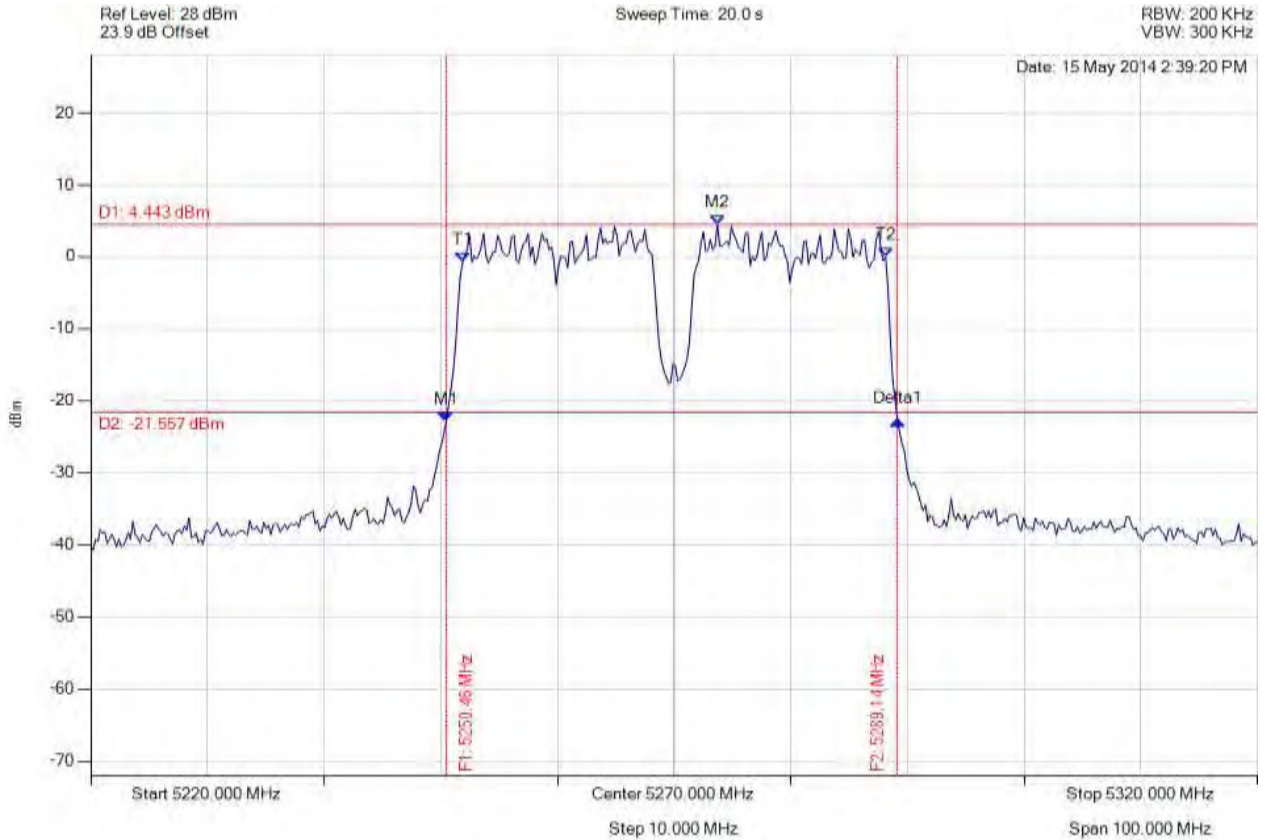

Analyser Setup	Marker : Frequency : Amplitude	Test Results
Detector = MAX PEAK Sweep Count = 0 RF Atten (dB) = 20 Trace Mode = VIEW	M1 : 5250.461 MHz : -22.913 dBm M2 : 5273.707 MHz : 4.443 dBm Delta1 : 38.677 MHz : 0.246 dB T1 : 5251.864 MHz : -0.729 dBm T2 : 5288.136 MHz : -0.041 dBm OBW : 36.273 MHz	Measured 26 dB Bandwidth: 38.677 MHz Measured 99% Bandwidth: 36.273 MHz

[Back to the Matrix](#)

This test report may be reproduced in full only. The document may only be updated by MiCOM Labs personnel. Any changes will be noted in the Document History section of the report.



Title: Aruba Networks APIN0214, APIN0215
To: FCC 47 CFR Part 15.407 & IC RSS-210
Serial #: ARUB179-U8 Rev B
Issue Date: 2nd September 2014
Page: 204 of 330



26 dB & 99% BANDWIDTH

Variant: 802.11n HT-40, Channel: 5270.00 MHz, Chain b, Temp: Ambient, Voltage: 12 Vdc

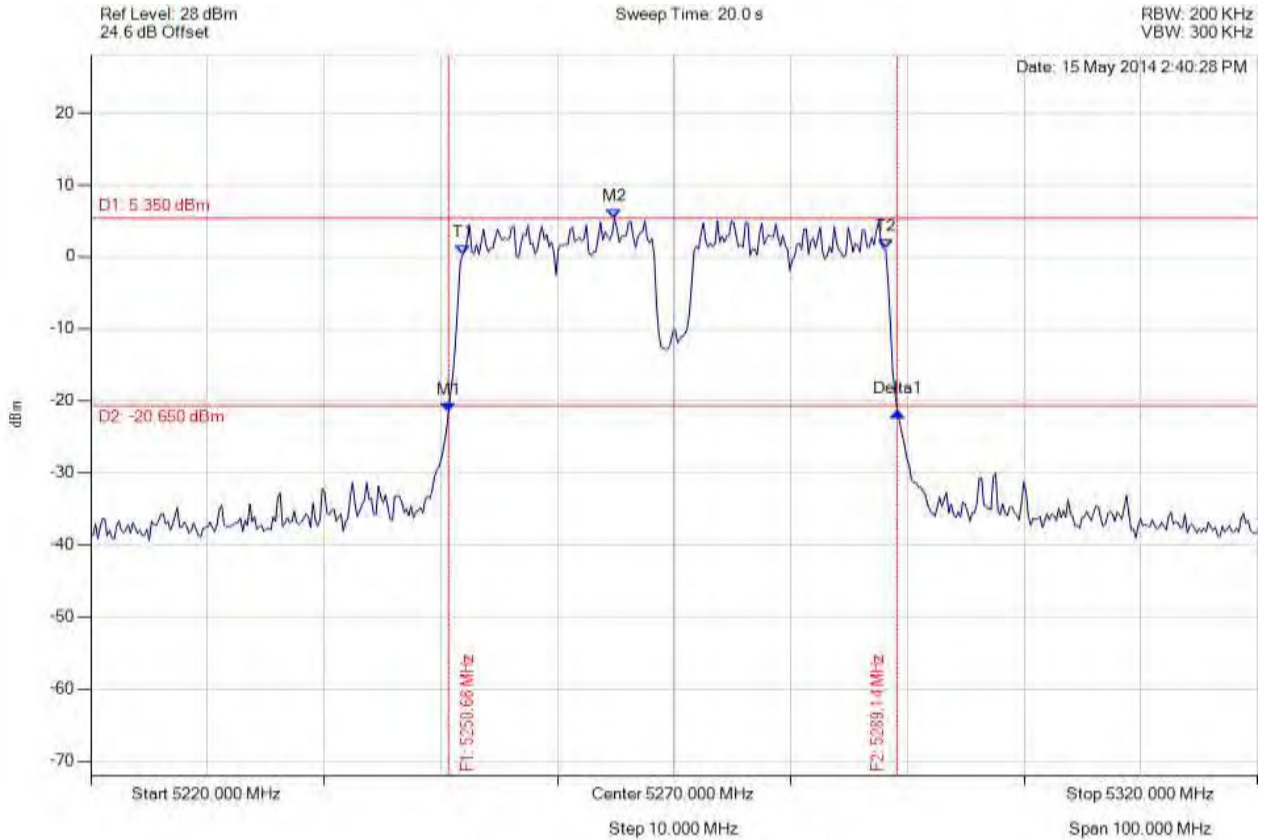

Analyser Setup	Marker : Frequency : Amplitude	Test Results
Detector = MAX PEAK Sweep Count = 0 RF Atten (dB) = 20 Trace Mode = VIEW	M1 : 5250.661 MHz : -21.564 dBm M2 : 5264.890 MHz : 5.350 dBm Delta1 : 38.477 MHz : 0.100 dB T1 : 5251.864 MHz : 0.302 dBm T2 : 5288.136 MHz : 1.055 dBm OBW : 36.273 MHz	Measured 26 dB Bandwidth: 38.477 MHz Measured 99% Bandwidth: 36.273 MHz

[Back to the Matrix](#)

This test report may be reproduced in full only. The document may only be updated by MiCOM Labs personnel. Any changes will be noted in the Document History section of the report.



Title: Aruba Networks APIN0214, APIN0215
To: FCC 47 CFR Part 15.407 & IC RSS-210
Serial #: ARUB179-U8 Rev B
Issue Date: 2nd September 2014
Page: 205 of 330



26 dB & 99% BANDWIDTH

Variant: 802.11n HT-40, Channel: 5270.00 MHz, Chain c, Temp: Ambient, Voltage: 12 Vdc

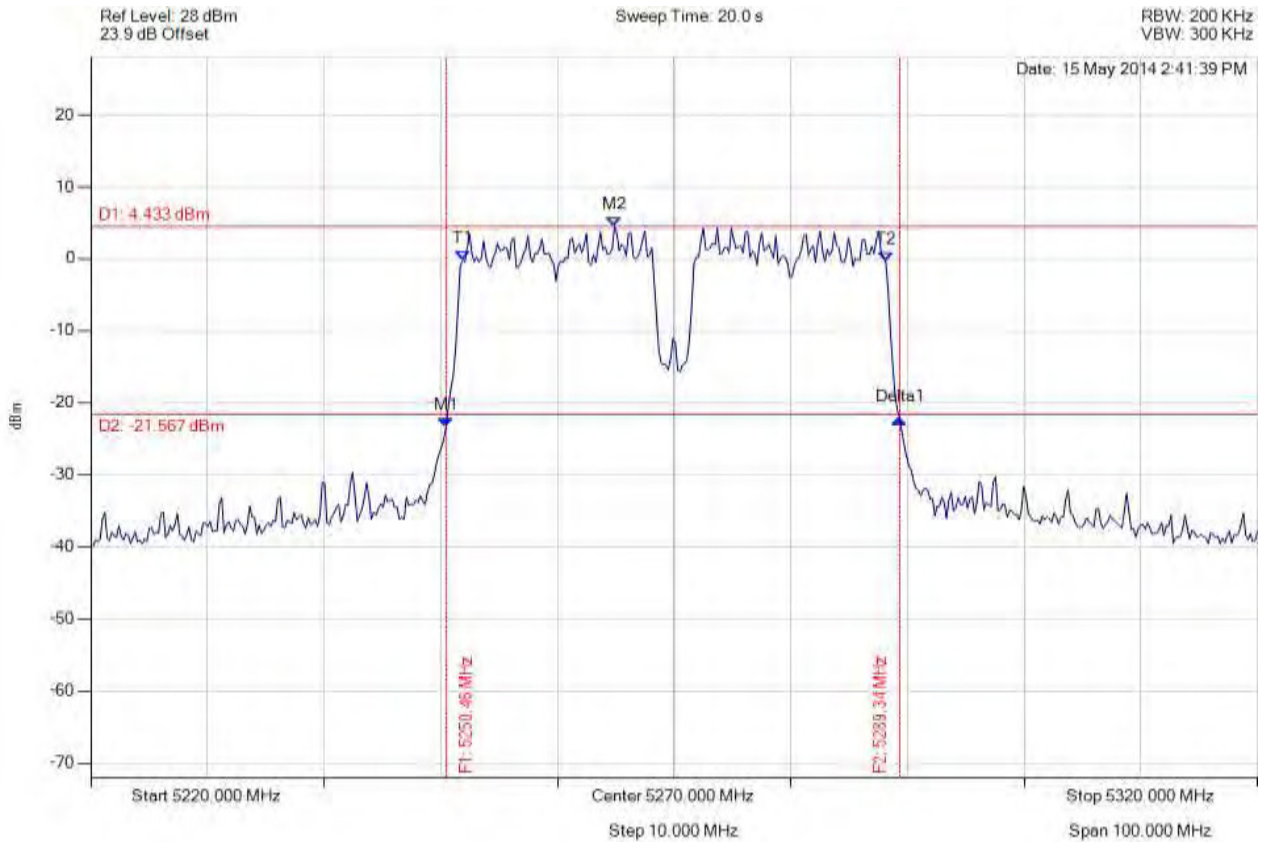

Analyser Setup	Marker : Frequency : Amplitude	Test Results
Detector = MAX PEAK Sweep Count = 0 RF Atten (dB) = 20 Trace Mode = VIEW	M1 : 5250.461 MHz : -23.376 dBm M2 : 5264.890 MHz : 4.433 dBm Delta1 : 38.878 MHz : 1.182 dB T1 : 5251.864 MHz : -0.180 dBm T2 : 5288.136 MHz : -0.409 dBm OBW : 36.273 MHz	Measured 26 dB Bandwidth: 38.878 MHz Measured 99% Bandwidth: 36.273 MHz

[Back to the Matrix](#)

This test report may be reproduced in full only. The document may only be updated by MiCOM Labs personnel. Any changes will be noted in the Document History section of the report.



Title: Aruba Networks APIN0214, APIN0215
To: FCC 47 CFR Part 15.407 & IC RSS-210
Serial #: ARUB179-U8 Rev B
Issue Date: 2nd September 2014
Page: 206 of 330



26 dB & 99% BANDWIDTH

Variant: 802.11n HT-40, Channel: 5310.00 MHz, Chain a, Temp: Ambient, Voltage: 12 Vdc

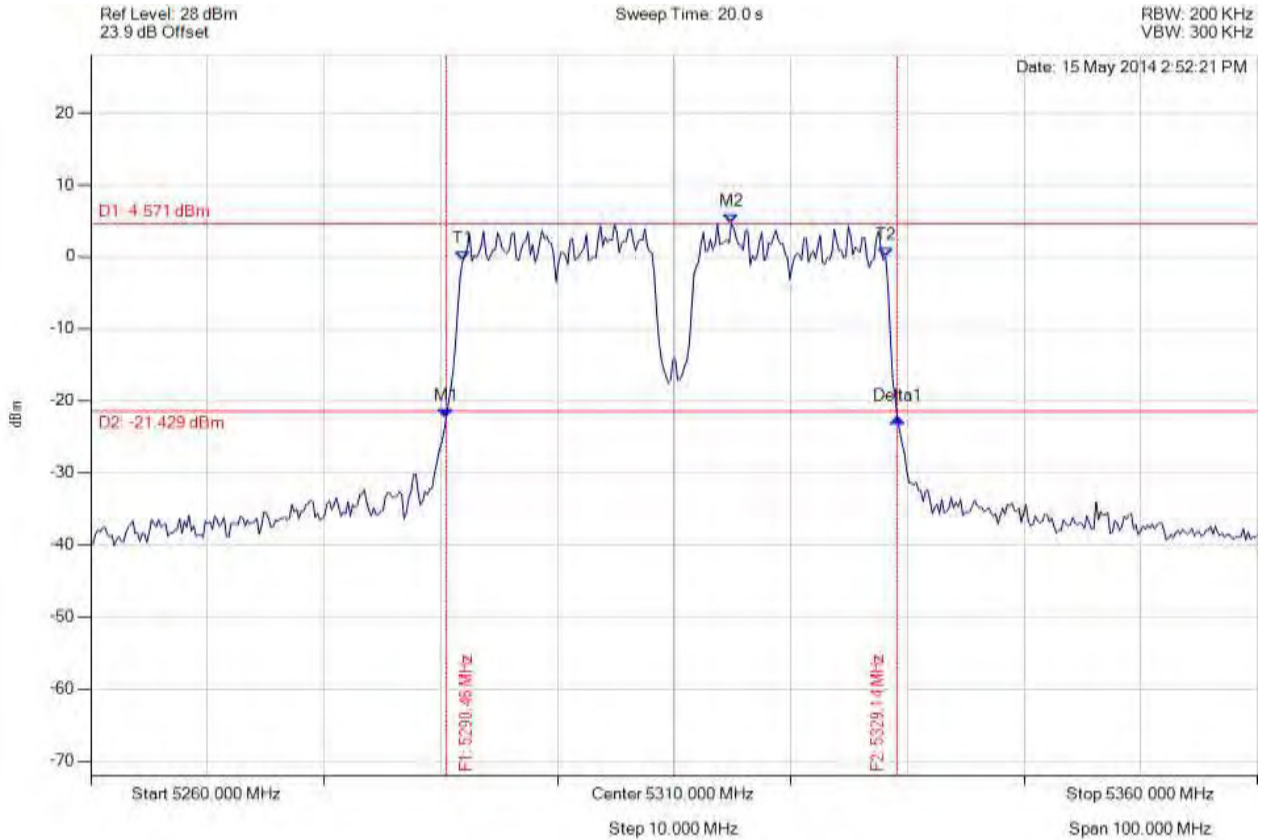

Analyser Setup	Marker : Frequency : Amplitude	Test Results
Detector = MAX PEAK Sweep Count = 0 RF Atten (dB) = 20 Trace Mode = VIEW	M1 : 5290.461 MHz : -22.419 dBm M2 : 5314.910 MHz : 4.571 dBm Delta1 : 38.677 MHz : -0.028 dB T1 : 5291.864 MHz : -0.607 dBm T2 : 5328.136 MHz : 0.014 dBm OBW : 36.273 MHz	Measured 26 dB Bandwidth: 38.677 MHz Measured 99% Bandwidth: 36.273 MHz

[Back to the Matrix](#)

This test report may be reproduced in full only. The document may only be updated by MiCOM Labs personnel. Any changes will be noted in the Document History section of the report.



Title: Aruba Networks APIN0214, APIN0215
To: FCC 47 CFR Part 15.407 & IC RSS-210
Serial #: ARUB179-U8 Rev B
Issue Date: 2nd September 2014
Page: 207 of 330



26 dB & 99% BANDWIDTH

Variant: 802.11n HT-40, Channel: 5310.00 MHz, Chain b, Temp: Ambient, Voltage: 12 Vdc

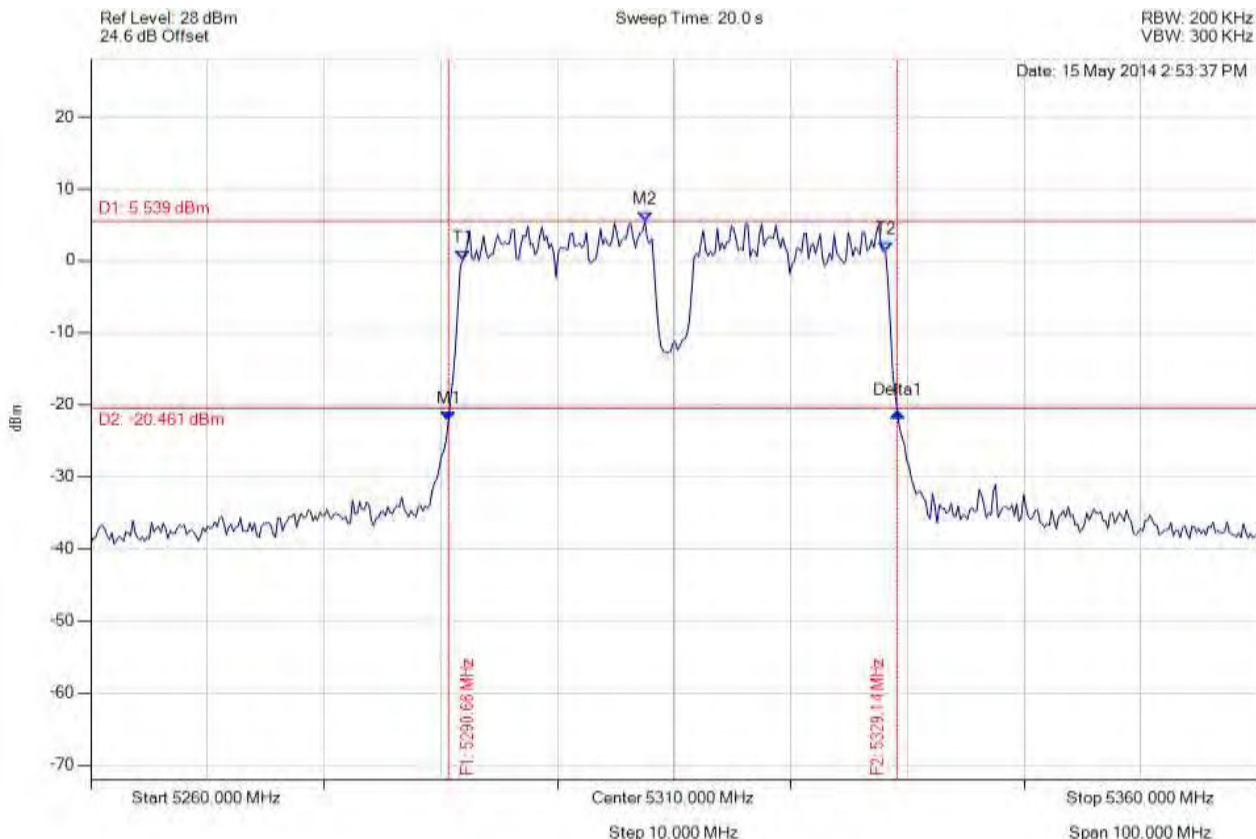

Analyser Setup	Marker : Frequency : Amplitude	Test Results
Detector = MAX PEAK Sweep Count = 0 RF Atten (dB) = 20 Trace Mode = VIEW	M1 : 5290.661 MHz : -22.274 dBm M2 : 5307.495 MHz : 5.539 dBm Delta1 : 38.477 MHz : 1.224 dB T1 : 5291.864 MHz : 0.150 dBm T2 : 5328.136 MHz : 1.232 dBm OBW : 36.273 MHz	Measured 26 dB Bandwidth: 38.477 MHz Measured 99% Bandwidth: 36.273 MHz

[Back to the Matrix](#)

This test report may be reproduced in full only. The document may only be updated by MiCOM Labs personnel. Any changes will be noted in the Document History section of the report.



Title: Aruba Networks APIN0214, APIN0215
To: FCC 47 CFR Part 15.407 & IC RSS-210
Serial #: ARUB179-U8 Rev B
Issue Date: 2nd September 2014
Page: 208 of 330



26 dB & 99% BANDWIDTH

Variant: 802.11n HT-40, Channel: 5310.00 MHz, Chain c, Temp: Ambient, Voltage: 12 Vdc

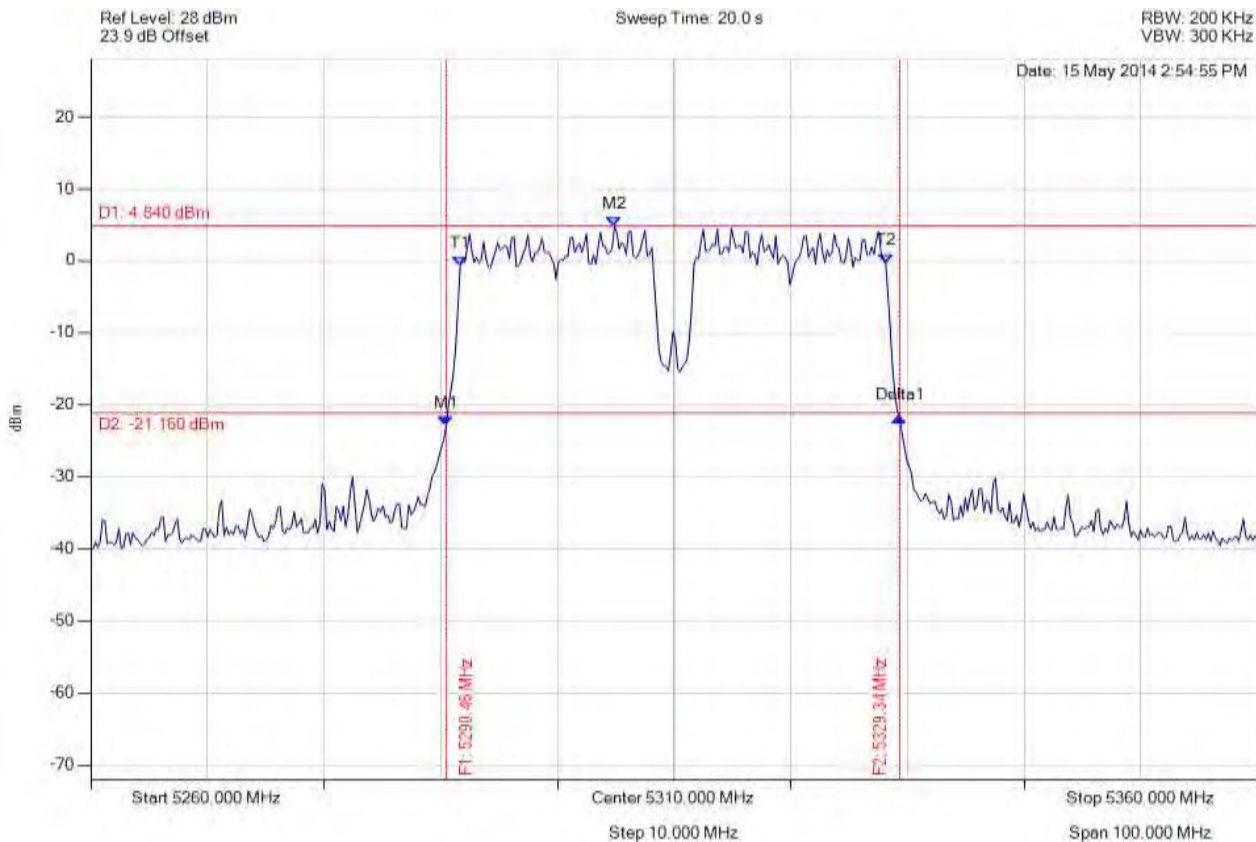

Analyser Setup	Marker : Frequency : Amplitude	Test Results
Detector = MAX PEAK Sweep Count = 0 RF Atten (dB) = 20 Trace Mode = VIEW	M1 : 5290.461 MHz : -22.945 dBm M2 : 5304.890 MHz : 4.840 dBm Delta1 : 38.878 MHz : 1.169 dB T1 : 5291.663 MHz : -0.727 dBm T2 : 5328.136 MHz : -0.281 dBm OBW : 36.473 MHz	Measured 26 dB Bandwidth: 38.878 MHz Measured 99% Bandwidth: 36.473 MHz

[Back to the Matrix](#)

This test report may be reproduced in full only. The document may only be updated by MiCOM Labs personnel. Any changes will be noted in the Document History section of the report.



Title: Aruba Networks APIN0214, APIN0215
To: FCC 47 CFR Part 15.407 & IC RSS-210
Serial #: ARUB179-U8 Rev B
Issue Date: 2nd September 2014
Page: 209 of 330



26 dB & 99% BANDWIDTH

Variant: 802.11a, Channel: 5500.00 MHz, Chain a, Temp: Ambient, Voltage: 12 Vdc

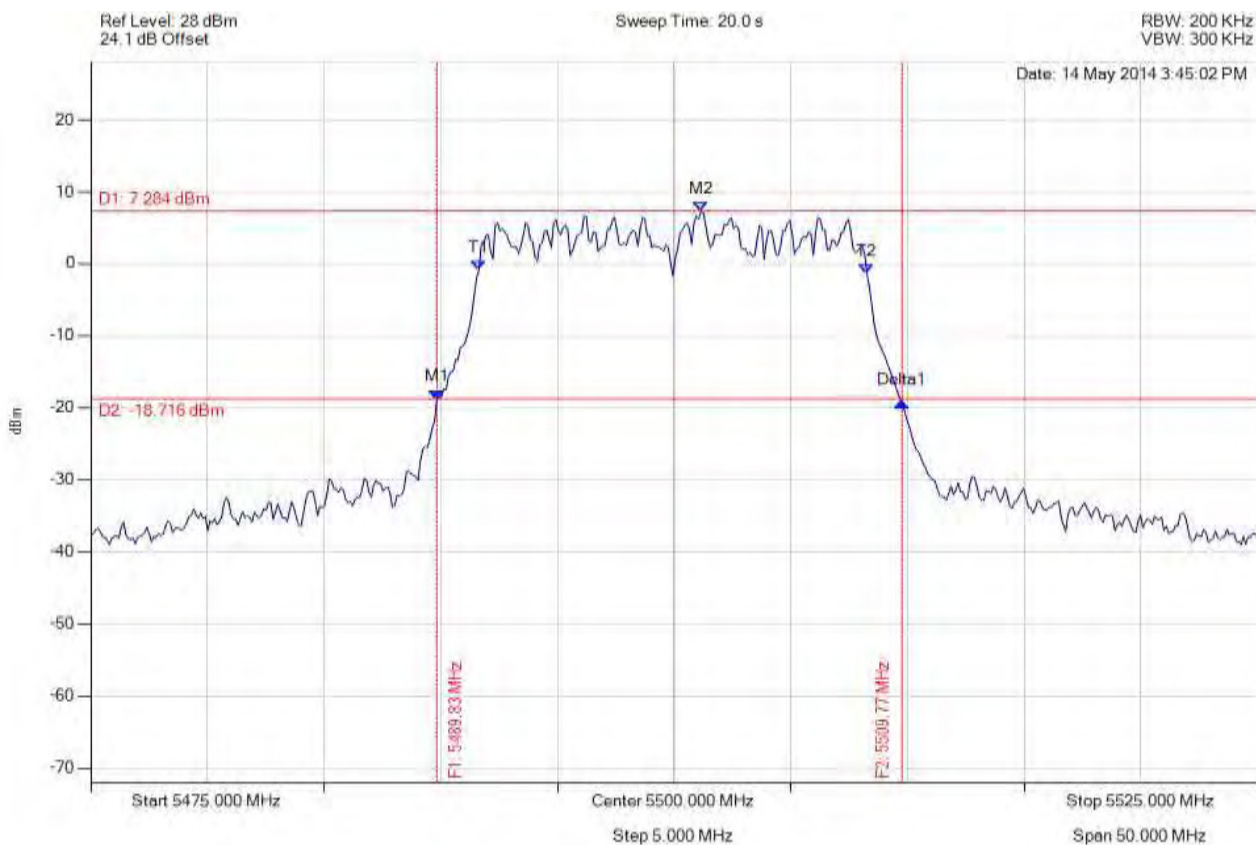

Analyser Setup	Marker : Frequency : Amplitude	Test Results
Detector = MAX PEAK Sweep Count = 0 RF Atten (dB) = 20 Trace Mode = VIEW	M1 : 5489.830 MHz : -18.796 dBm M2 : 5501.152 MHz : 7.284 dBm Delta1 : 19.940 MHz : -0.423 dB T1 : 5491.633 MHz : -0.887 dBm T2 : 5508.267 MHz : -1.355 dBm OBW : 16.633 MHz	Measured 26 dB Bandwidth: 19.940 MHz Measured 99% Bandwidth: 16.633 MHz

[Back to the Matrix](#)

This test report may be reproduced in full only. The document may only be updated by MiCOM Labs personnel. Any changes will be noted in the Document History section of the report.



Title: Aruba Networks APIN0214, APIN0215
To: FCC 47 CFR Part 15.407 & IC RSS-210
Serial #: ARUB179-U8 Rev B
Issue Date: 2nd September 2014
Page: 210 of 330



26 dB & 99% BANDWIDTH

Variant: 802.11a, Channel: 5500.00 MHz, Chain b, Temp: Ambient, Voltage: 12 Vdc

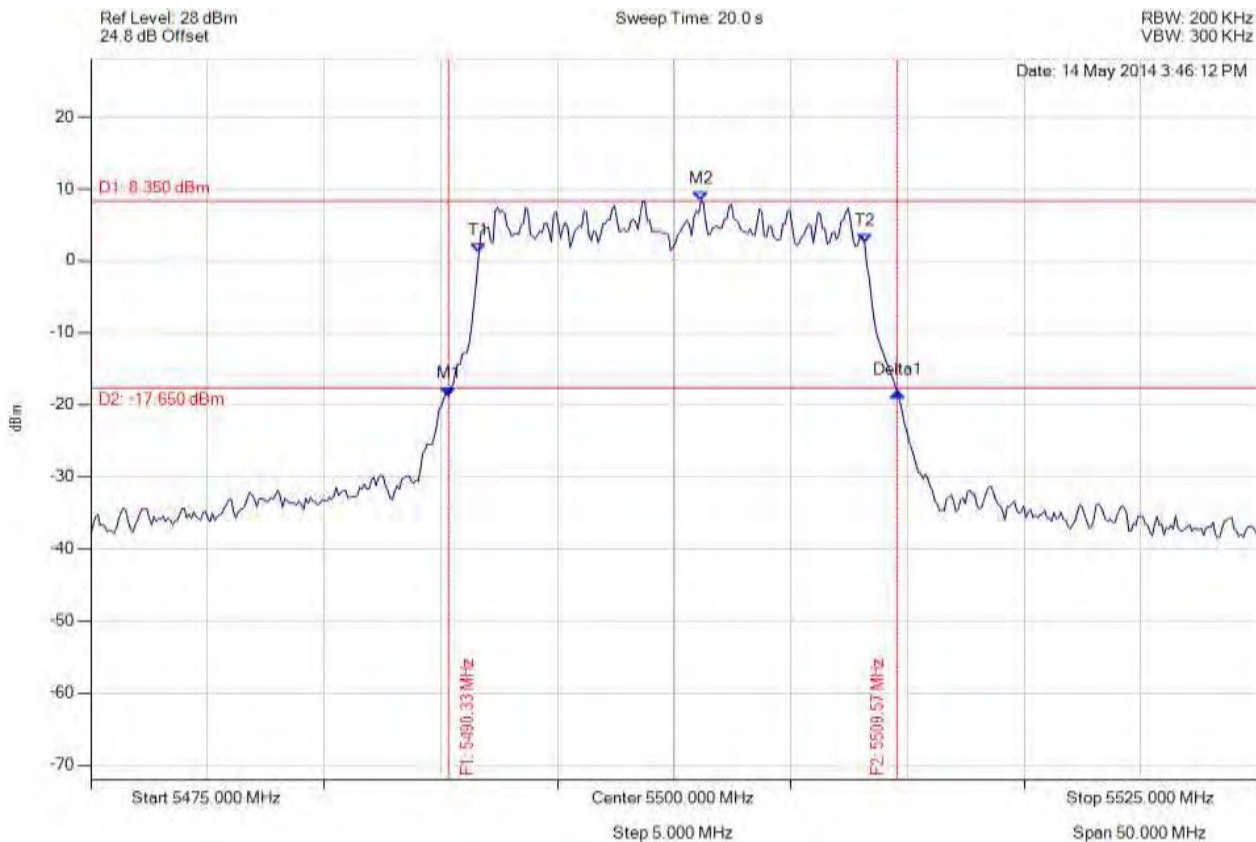

Analyser Setup	Marker : Frequency : Amplitude	Test Results
Detector = MAX PEAK Sweep Count = 0 RF Atten (dB) = 20 Trace Mode = VIEW	M1 : 5490.331 MHz : -18.796 dBm M2 : 5501.152 MHz : 8.350 dBm Delta1 : 19.238 MHz : 0.547 dB T1 : 5491.633 MHz : 1.118 dBm T2 : 5508.166 MHz : 2.462 dBm OBW : 16.533 MHz	Measured 26 dB Bandwidth: 19.238 MHz Measured 99% Bandwidth: 16.533 MHz

[Back to the Matrix](#)

This test report may be reproduced in full only. The document may only be updated by MiCOM Labs personnel. Any changes will be noted in the Document History section of the report.



Title: Aruba Networks APIN0214, APIN0215
To: FCC 47 CFR Part 15.407 & IC RSS-210
Serial #: ARUB179-U8 Rev B
Issue Date: 2nd September 2014
Page: 211 of 330



26 dB & 99% BANDWIDTH

Variant: 802.11a, Channel: 5500.00 MHz, Chain c, Temp: Ambient, Voltage: 12 Vdc

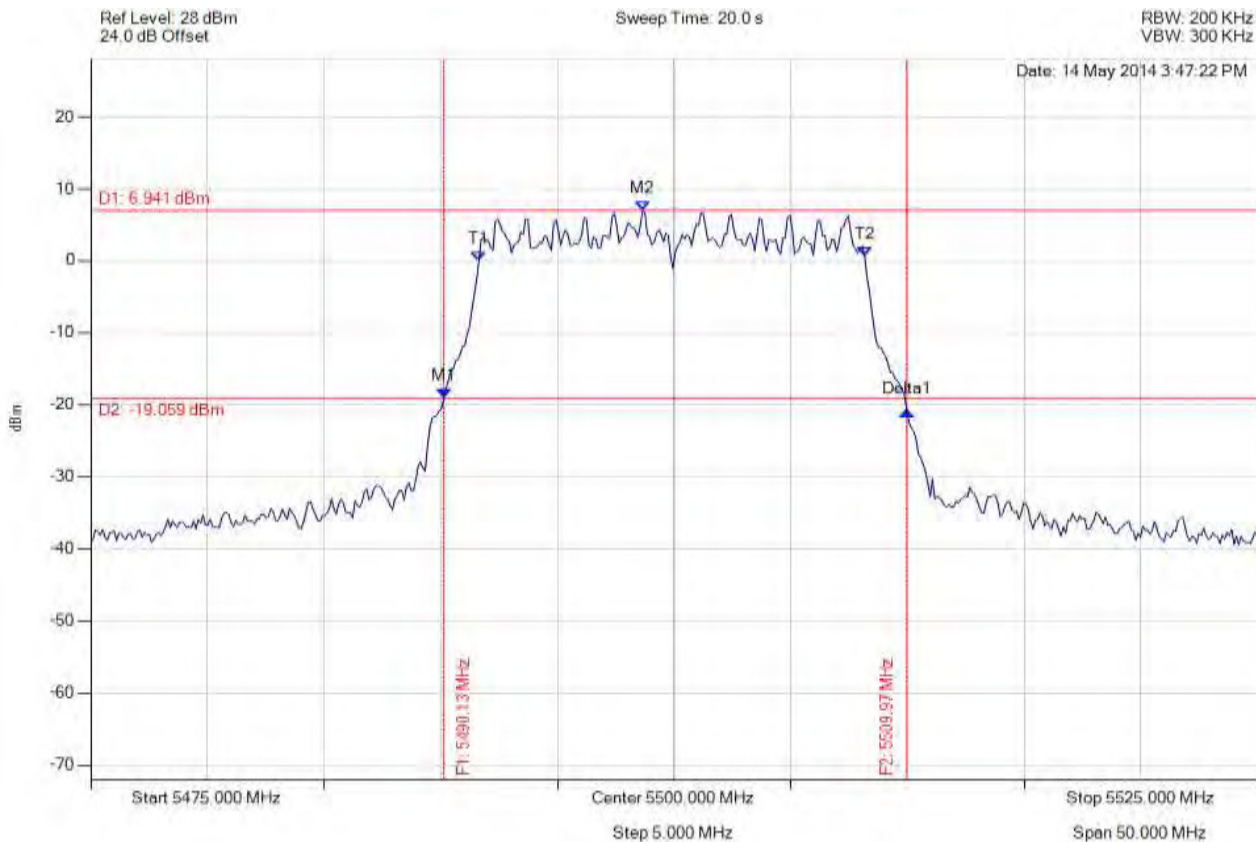

Analyser Setup	Marker : Frequency : Amplitude	Test Results
Detector = MAX PEAK Sweep Count = 0 RF Atten (dB) = 20 Trace Mode = VIEW	M1 : 5490.130 MHz : -19.106 dBm M2 : 5498.647 MHz : 6.941 dBm Delta1 : 19.840 MHz : -1.847 dB T1 : 5491.633 MHz : -0.009 dBm T2 : 5508.166 MHz : 0.597 dBm OBW : 16.533 MHz	Measured 26 dB Bandwidth: 19.840 MHz Measured 99% Bandwidth: 16.533 MHz

[Back to the Matrix](#)

This test report may be reproduced in full only. The document may only be updated by MiCOM Labs personnel. Any changes will be noted in the Document History section of the report.



Title: Aruba Networks APIN0214, APIN0215
To: FCC 47 CFR Part 15.407 & IC RSS-210
Serial #: ARUB179-U8 Rev B
Issue Date: 2nd September 2014
Page: 212 of 330



26 dB & 99% BANDWIDTH

Variant: 802.11a, Channel: 5580.00 MHz, Chain a, Temp: Ambient, Voltage: 12 Vdc

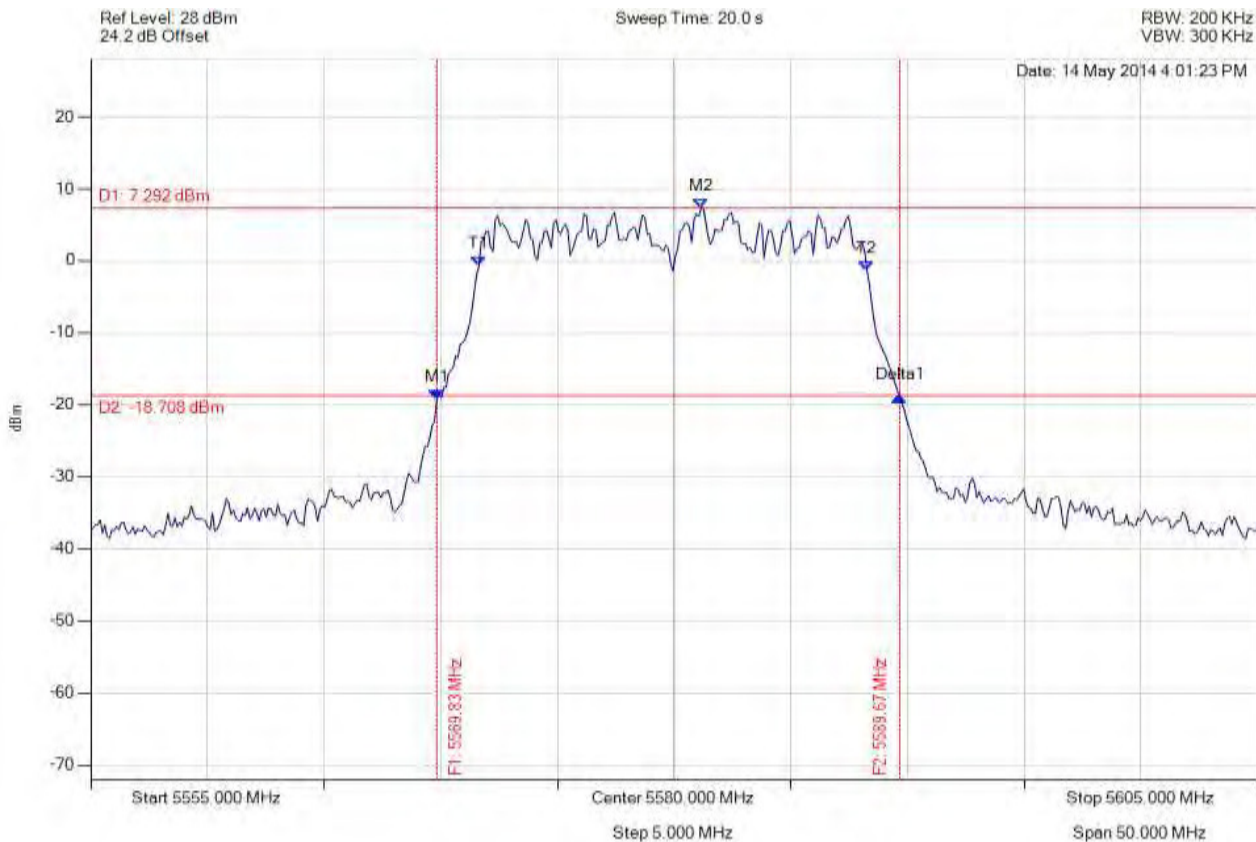

Analyser Setup	Marker : Frequency : Amplitude	Test Results
Detector = MAX PEAK Sweep Count = 0 RF Atten (dB) = 20 Trace Mode = VIEW	M1 : 5569.830 MHz : -19.161 dBm M2 : 5581.152 MHz : 7.292 dBm Delta1 : 19.840 MHz : 0.281 dB T1 : 5571.633 MHz : -0.769 dBm T2 : 5588.267 MHz : -1.306 dBm OBW : 16.633 MHz	Measured 26 dB Bandwidth: 19.840 MHz Measured 99% Bandwidth: 16.633 MHz

[Back to the Matrix](#)

This test report may be reproduced in full only. The document may only be updated by MiCOM Labs personnel. Any changes will be noted in the Document History section of the report.



Title: Aruba Networks APIN0214, APIN0215
To: FCC 47 CFR Part 15.407 & IC RSS-210
Serial #: ARUB179-U8 Rev B
Issue Date: 2nd September 2014
Page: 213 of 330



26 dB & 99% BANDWIDTH

Variant: 802.11a, Channel: 5580.00 MHz, Chain b, Temp: Ambient, Voltage: 12 Vdc

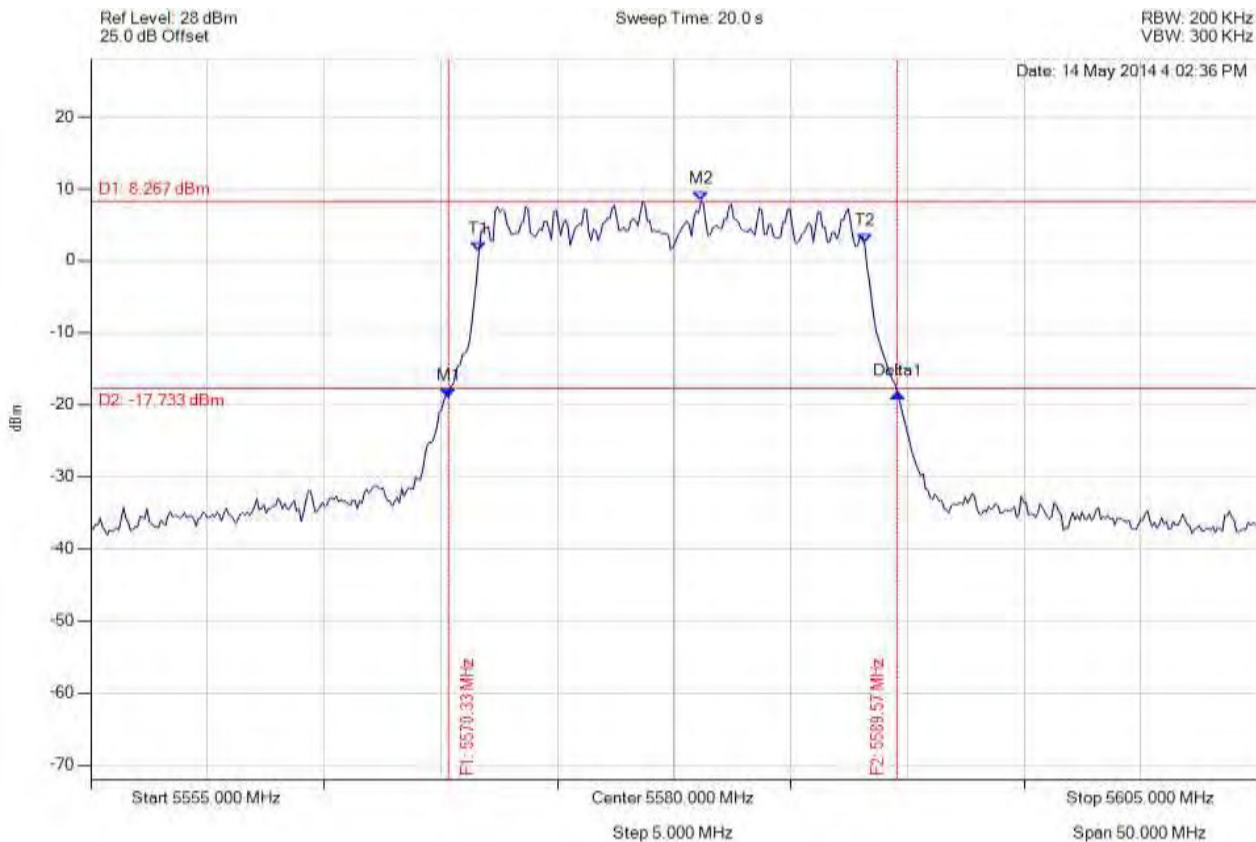

Analyser Setup	Marker : Frequency : Amplitude	Test Results
Detector = MAX PEAK Sweep Count = 0 RF Atten (dB) = 20 Trace Mode = VIEW	M1 : 5570.331 MHz : -19.000 dBm M2 : 5581.152 MHz : 8.267 dBm Delta1 : 19.238 MHz : 0.618 dB T1 : 5571.633 MHz : 1.266 dBm T2 : 5588.166 MHz : 2.422 dBm OBW : 16.533 MHz	Measured 26 dB Bandwidth: 19.238 MHz Measured 99% Bandwidth: 16.533 MHz

[Back to the Matrix](#)

This test report may be reproduced in full only. The document may only be updated by MiCOM Labs personnel. Any changes will be noted in the Document History section of the report.



Title: Aruba Networks APIN0214, APIN0215
To: FCC 47 CFR Part 15.407 & IC RSS-210
Serial #: ARUB179-U8 Rev B
Issue Date: 2nd September 2014
Page: 214 of 330



26 dB & 99% BANDWIDTH

Variant: 802.11a, Channel: 5580.00 MHz, Chain c, Temp: Ambient, Voltage: 12 Vdc

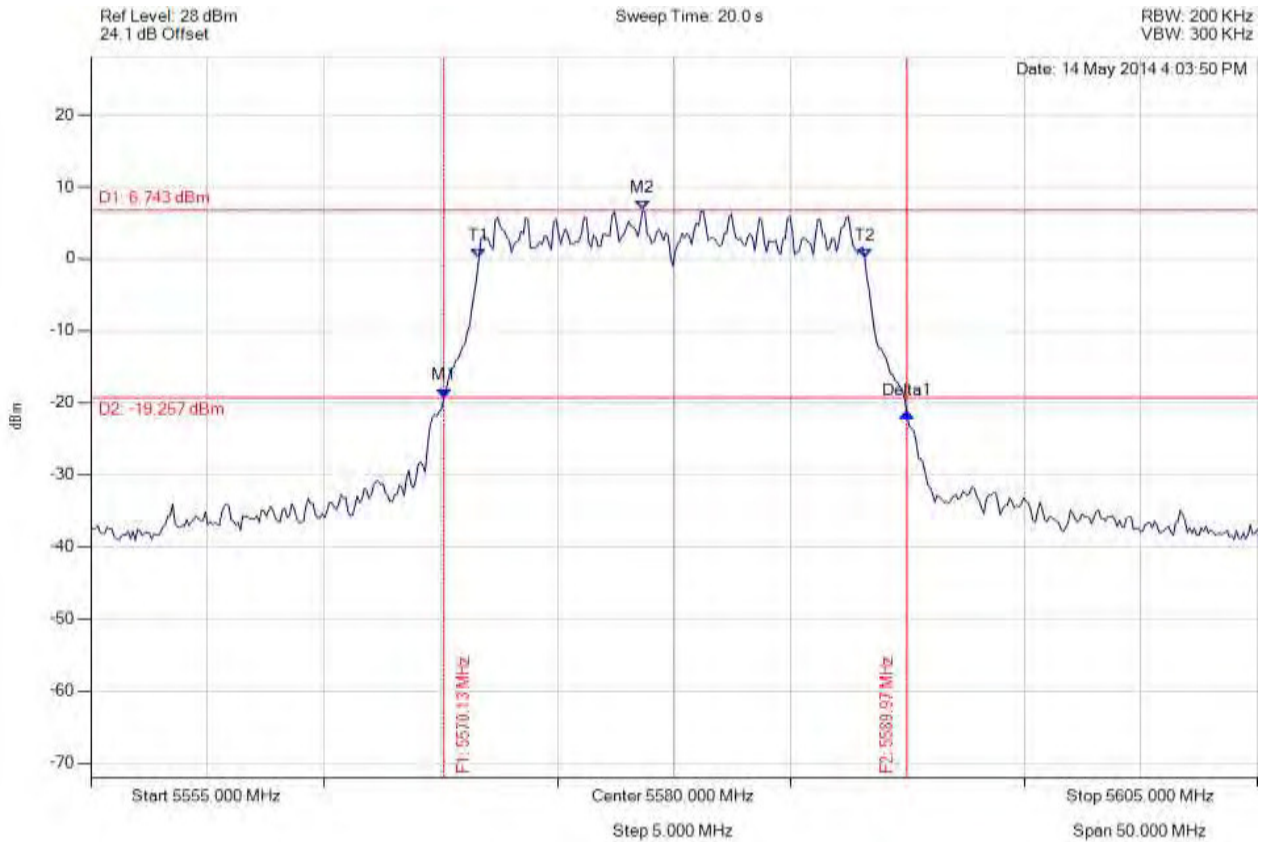

Analyser Setup	Marker : Frequency : Amplitude	Test Results
Detector = MAX PEAK Sweep Count = 0 RF Atten (dB) = 20 Trace Mode = VIEW	M1 : 5570.130 MHz : -19.305 dBm M2 : 5578.647 MHz : 6.743 dBm Delta1 : 19.840 MHz : -2.144 dB T1 : 5571.633 MHz : 0.103 dBm T2 : 5588.166 MHz : 0.113 dBm OBW : 16.533 MHz	Measured 26 dB Bandwidth: 19.840 MHz Measured 99% Bandwidth: 16.533 MHz

[Back to the Matrix](#)

This test report may be reproduced in full only. The document may only be updated by MiCOM Labs personnel. Any changes will be noted in the Document History section of the report.



Title: Aruba Networks APIN0214, APIN0215
To: FCC 47 CFR Part 15.407 & IC RSS-210
Serial #: ARUB179-U8 Rev B
Issue Date: 2nd September 2014
Page: 215 of 330



26 dB & 99% BANDWIDTH

Variant: 802.11a, Channel: 5720.00 MHz, Chain a, Temp: Ambient, Voltage: 12 Vdc

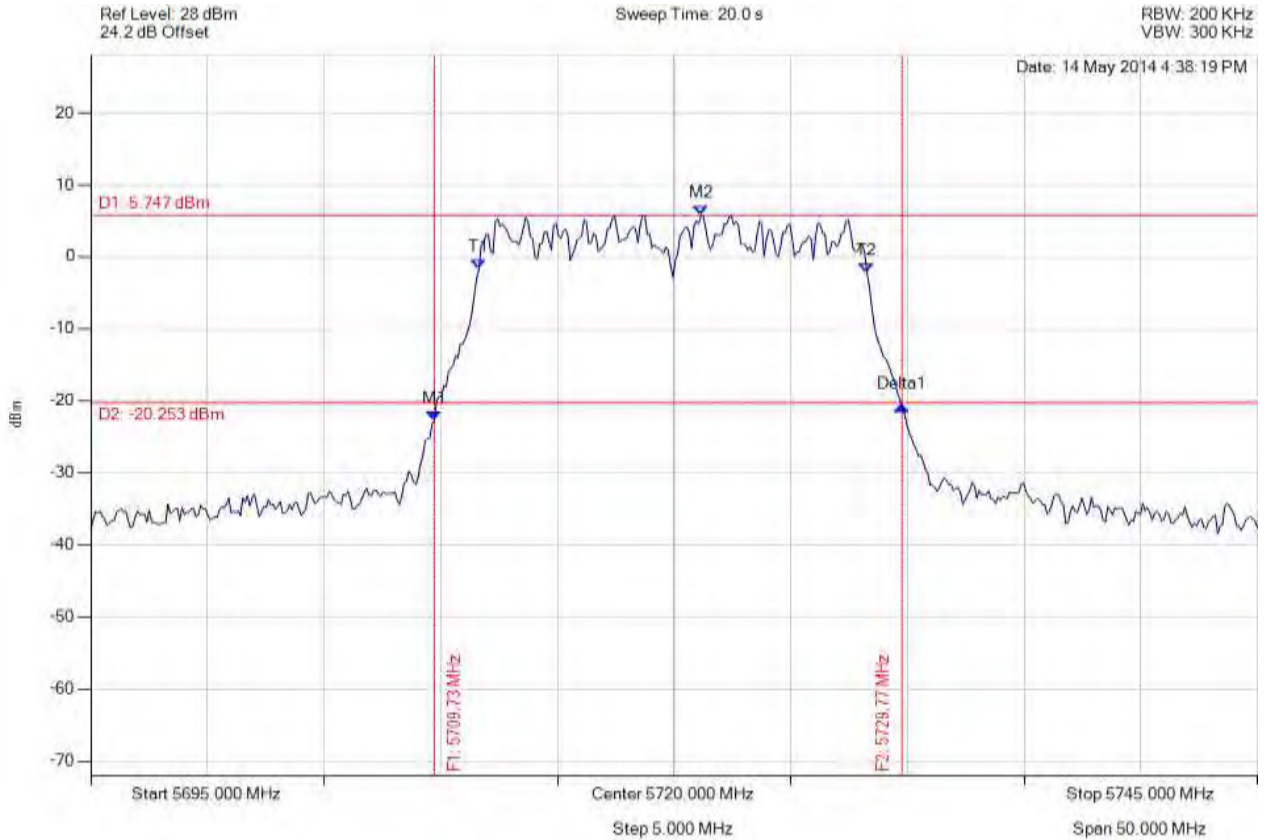

Analyser Setup	Marker : Frequency : Amplitude	Test Results
Detector = MAX PEAK Sweep Count = 0 RF Atten (dB) = 20 Trace Mode = VIEW	M1 : 5709.729 MHz : -22.661 dBm M2 : 5721.152 MHz : 5.747 dBm Delta1 : 20.040 MHz : 2.011 dB T1 : 5711.633 MHz : -1.741 dBm T2 : 5728.267 MHz : -2.165 dBm OBW : 16.633 MHz	Measured 26 dB Bandwidth: 20.040 MHz Measured 99% Bandwidth: 16.633 MHz

[Back to the Matrix](#)

This test report may be reproduced in full only. The document may only be updated by MiCOM Labs personnel. Any changes will be noted in the Document History section of the report.



Title: Aruba Networks APIN0214, APIN0215
To: FCC 47 CFR Part 15.407 & IC RSS-210
Serial #: ARUB179-U8 Rev B
Issue Date: 2nd September 2014
Page: 216 of 330



26 dB & 99% BANDWIDTH

Variant: 802.11a, Channel: 5720.00 MHz, Chain b, Temp: Ambient, Voltage: 12 Vdc

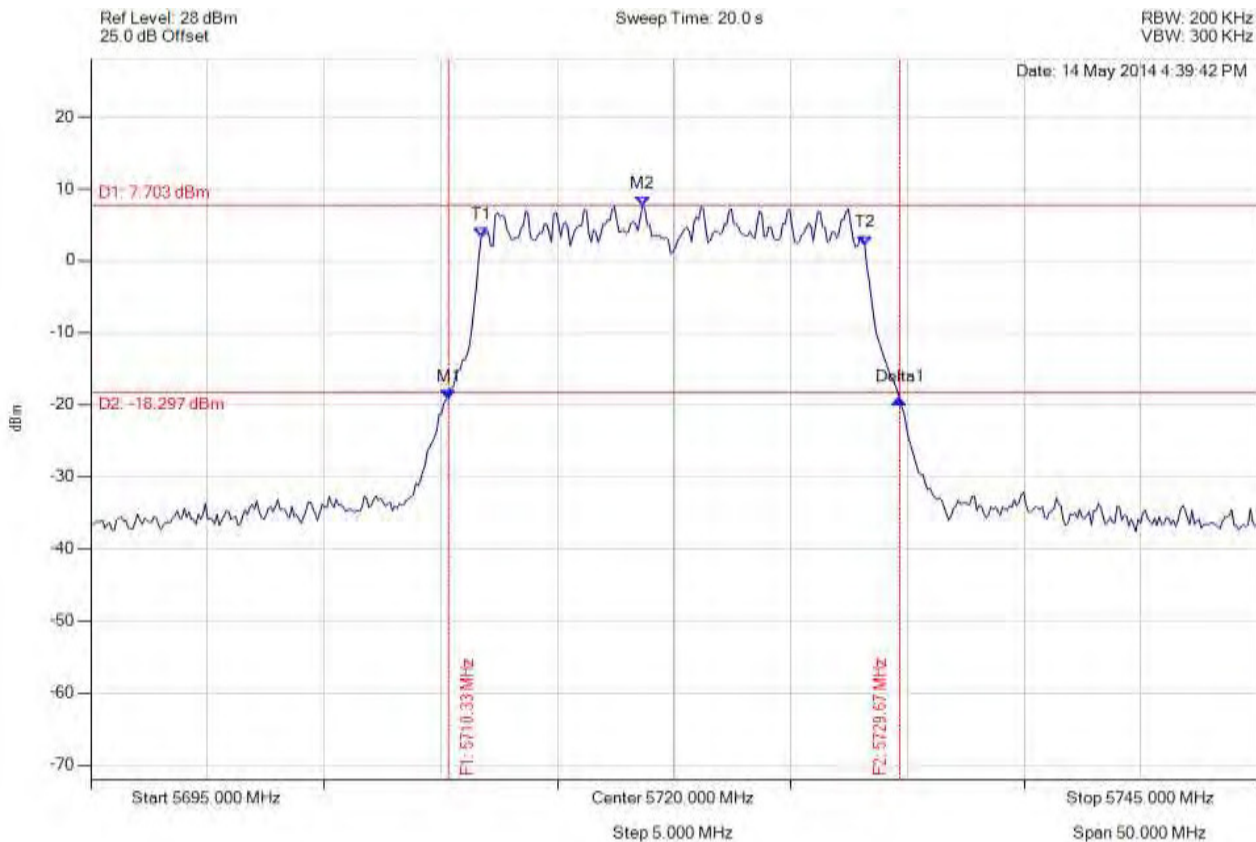

Analyser Setup	Marker : Frequency : Amplitude	Test Results
Detector = MAX PEAK Sweep Count = 0 RF Atten (dB) = 20 Trace Mode = VIEW	M1 : 5710.331 MHz : -19.215 dBm M2 : 5718.647 MHz : 7.703 dBm Delta1 : 19.339 MHz : -0.022 dB T1 : 5711.733 MHz : 3.347 dBm T2 : 5728.166 MHz : 2.210 dBm OBW : 16.433 MHz	Measured 26 dB Bandwidth: 19.339 MHz Measured 99% Bandwidth: 16.433 MHz

[Back to the Matrix](#)

This test report may be reproduced in full only. The document may only be updated by MiCOM Labs personnel. Any changes will be noted in the Document History section of the report.



Title: Aruba Networks APIN0214, APIN0215
To: FCC 47 CFR Part 15.407 & IC RSS-210
Serial #: ARUB179-U8 Rev B
Issue Date: 2nd September 2014
Page: 217 of 330



26 dB & 99% BANDWIDTH

Variant: 802.11a, Channel: 5720.00 MHz, Chain c, Temp: Ambient, Voltage: 12 Vdc

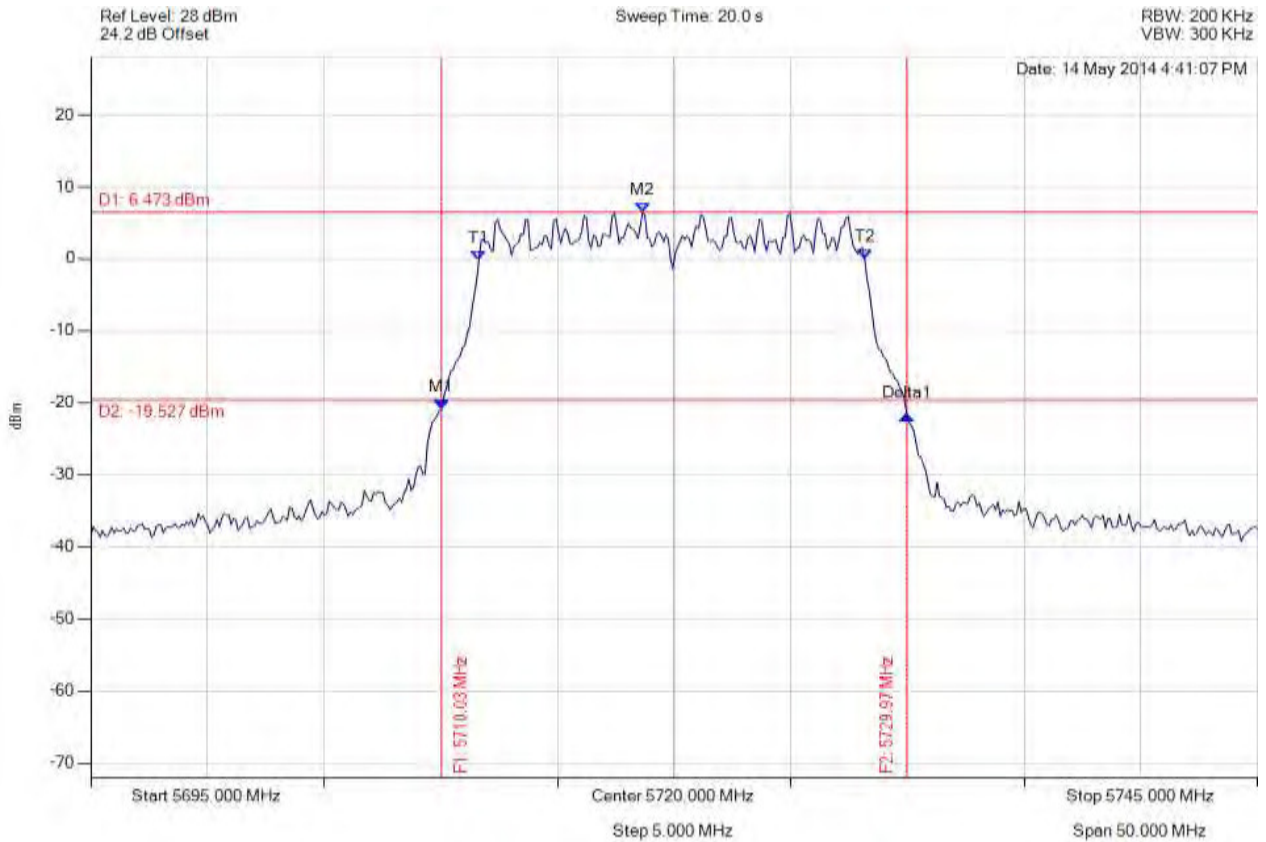

Analyser Setup	Marker : Frequency : Amplitude	Test Results
Detector = MAX PEAK Sweep Count = 0 RF Atten (dB) = 20 Trace Mode = VIEW	M1 : 5710.030 MHz : -20.877 dBm M2 : 5718.647 MHz : 6.473 dBm Delta1 : 19.940 MHz : -0.803 dB T1 : 5711.633 MHz : -0.192 dBm T2 : 5728.166 MHz : -0.072 dBm OBW : 16.533 MHz	Measured 26 dB Bandwidth: 19.940 MHz Measured 99% Bandwidth: 16.533 MHz

[Back to the Matrix](#)

This test report may be reproduced in full only. The document may only be updated by MiCOM Labs personnel. Any changes will be noted in the Document History section of the report.



Title: Aruba Networks APIN0214, APIN0215
To: FCC 47 CFR Part 15.407 & IC RSS-210
Serial #: ARUB179-U8 Rev B
Issue Date: 2nd September 2014
Page: 218 of 330



26 dB & 99% BANDWIDTH

Variant: 802.11ac-80, Channel: 5530.00 MHz, Chain a, Temp: Ambient, Voltage: 12 Vdc

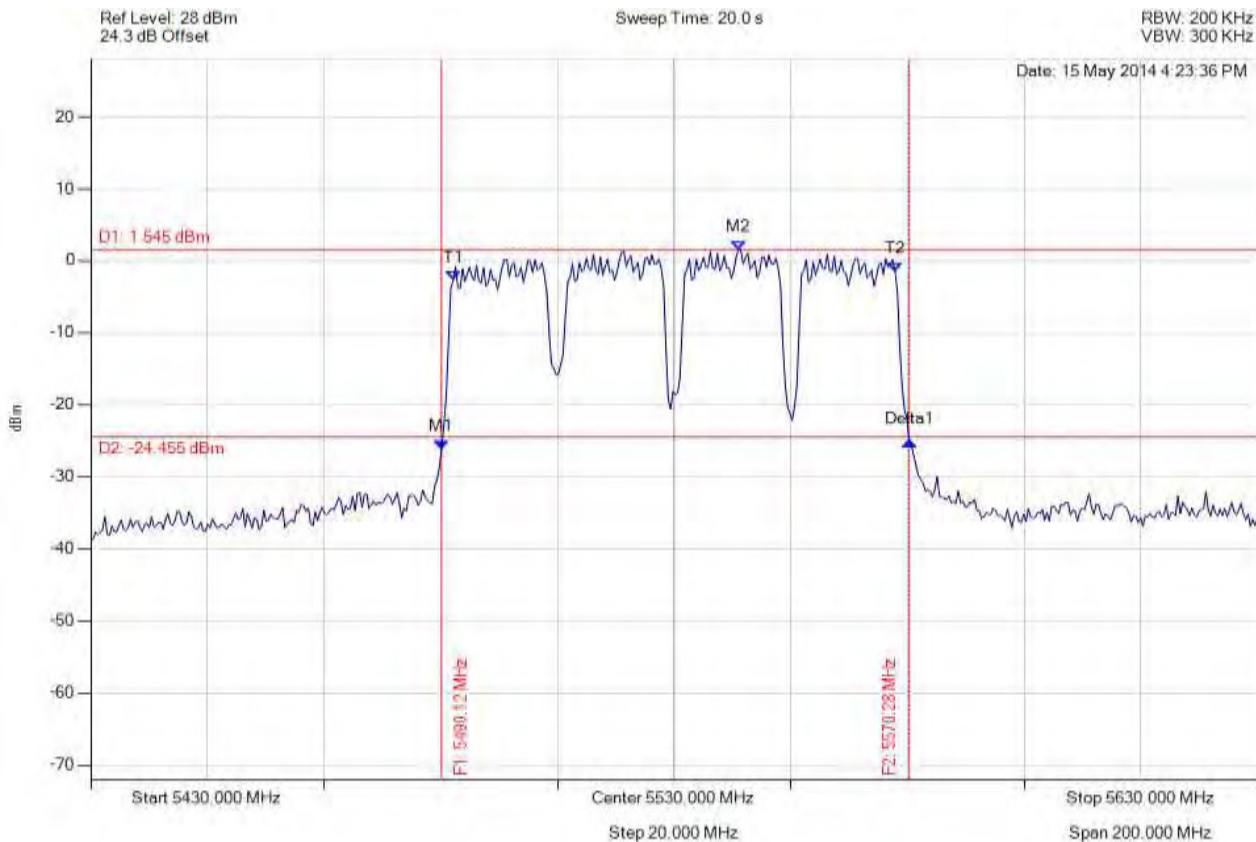

Analyser Setup	Marker : Frequency : Amplitude	Test Results
Detector = MAX PEAK Sweep Count = 0 RF Atten (dB) = 20 Trace Mode = VIEW	M1 : 5490.120 MHz : -26.138 dBm M2 : 5541.022 MHz : 1.545 dBm Delta1 : 80.160 MHz : 1.015 dB T1 : 5492.124 MHz : -2.730 dBm T2 : 5567.876 MHz : -1.449 dBm OBW : 75.752 MHz	Measured 26 dB Bandwidth: 80.160 MHz Measured 99% Bandwidth: 75.752 MHz

[Back to the Matrix](#)

This test report may be reproduced in full only. The document may only be updated by MiCOM Labs personnel. Any changes will be noted in the Document History section of the report.



Title: Aruba Networks APIN0214, APIN0215
To: FCC 47 CFR Part 15.407 & IC RSS-210
Serial #: ARUB179-U8 Rev B
Issue Date: 2nd September 2014
Page: 219 of 330



26 dB & 99% BANDWIDTH

Variant: 802.11ac-80, Channel: 5530.00 MHz, Chain b, Temp: Ambient, Voltage: 12 Vdc

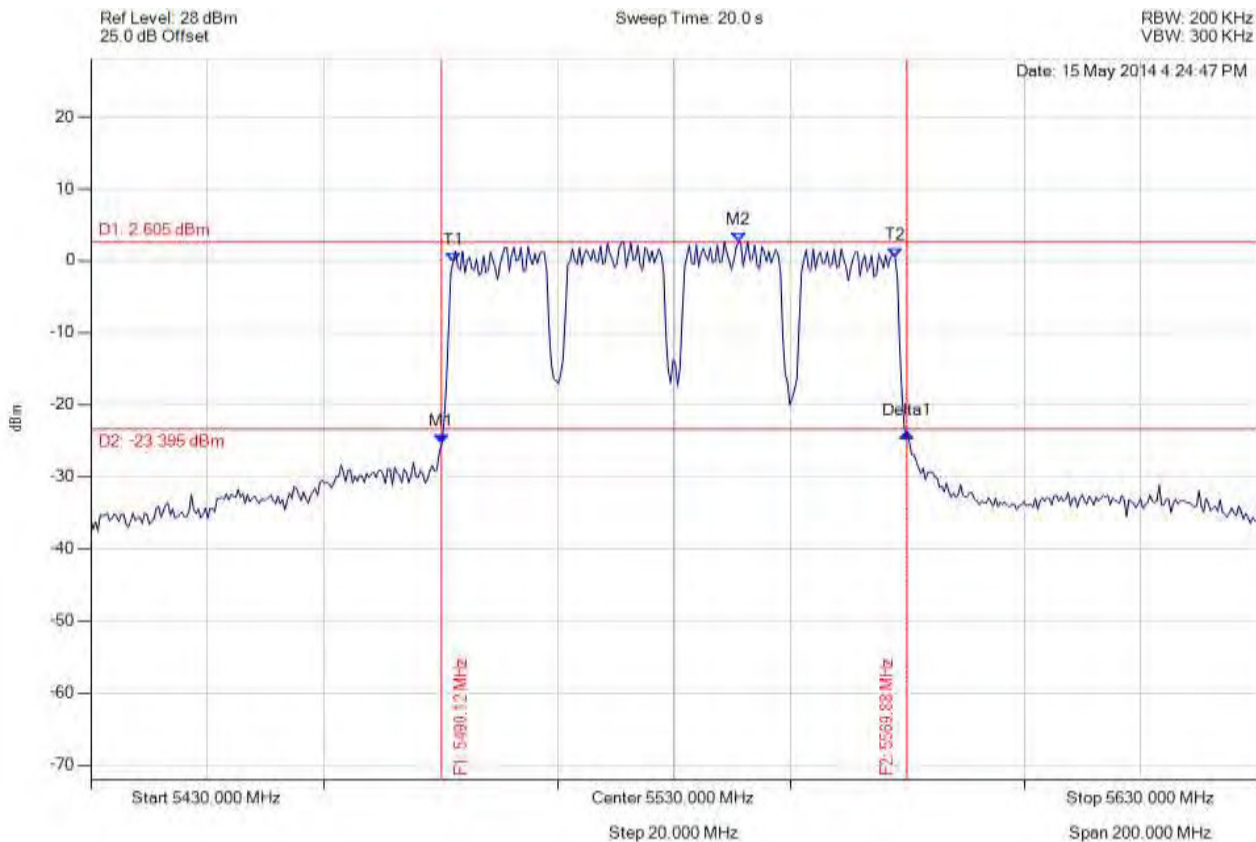

Analyser Setup	Marker : Frequency : Amplitude	Test Results
Detector = MAX PEAK Sweep Count = 0 RF Atten (dB) = 20 Trace Mode = VIEW	M1 : 5490.120 MHz : -25.422 dBm M2 : 5541.022 MHz : 2.605 dBm Delta1 : 79.760 MHz : 1.546 dB T1 : 5492.124 MHz : -0.180 dBm T2 : 5567.876 MHz : 0.530 dBm OBW : 75.752 MHz	Measured 26 dB Bandwidth: 79.760 MHz Measured 99% Bandwidth: 75.752 MHz

[Back to the Matrix](#)

This test report may be reproduced in full only. The document may only be updated by MiCOM Labs personnel. Any changes will be noted in the Document History section of the report.



Title: Aruba Networks APIN0214, APIN0215
To: FCC 47 CFR Part 15.407 & IC RSS-210
Serial #: ARUB179-U8 Rev B
Issue Date: 2nd September 2014
Page: 220 of 330



26 dB & 99% BANDWIDTH

Variant: 802.11ac-80, Channel: 5530.00 MHz, Chain c, Temp: Ambient, Voltage: 12 Vdc

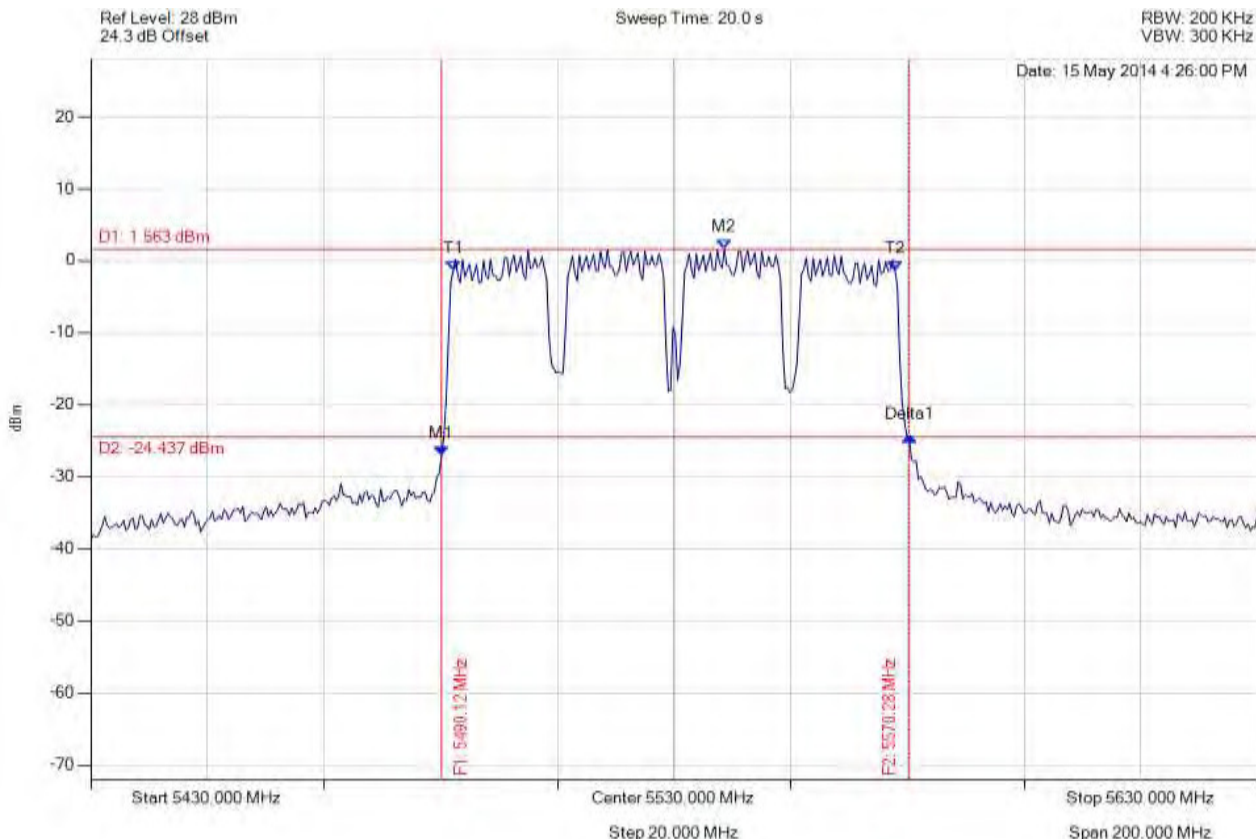

Analyser Setup	Marker : Frequency : Amplitude	Test Results
Detector = MAX PEAK Sweep Count = 0 RF Atten (dB) = 20 Trace Mode = VIEW	M1 : 5490.120 MHz : -26.986 dBm M2 : 5538.617 MHz : 1.563 dBm Delta1 : 80.160 MHz : 2.548 dB T1 : 5492.124 MHz : -1.434 dBm T2 : 5567.876 MHz : -1.339 dBm OBW : 75.752 MHz	Measured 26 dB Bandwidth: 80.160 MHz Measured 99% Bandwidth: 75.752 MHz

[Back to the Matrix](#)

This test report may be reproduced in full only. The document may only be updated by MiCOM Labs personnel. Any changes will be noted in the Document History section of the report.



Title: Aruba Networks APIN0214, APIN0215
To: FCC 47 CFR Part 15.407 & IC RSS-210
Serial #: ARUB179-U8 Rev B
Issue Date: 2nd September 2014
Page: 221 of 330



26 dB & 99% BANDWIDTH

Variant: 802.11ac-80, Channel: 5690.00 MHz, Chain a, Temp: Ambient, Voltage: 12 Vdc

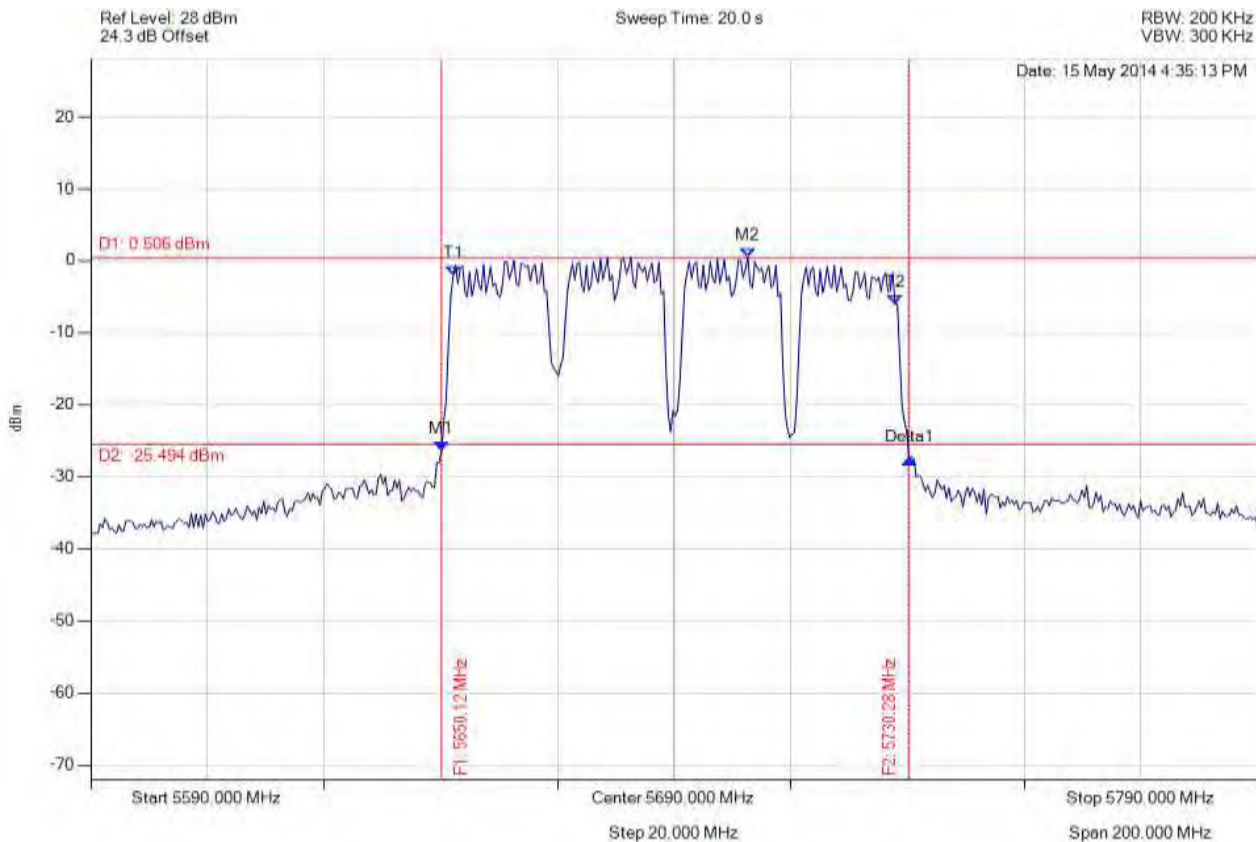

Analyser Setup	Marker : Frequency : Amplitude	Test Results
Detector = MAX PEAK Sweep Count = 0 RF Atten (dB) = 20 Trace Mode = VIEW	M1 : 5650.120 MHz : -26.403 dBm M2 : 5702.625 MHz : 0.506 dBm Delta1 : 80.160 MHz : -1.200 dB T1 : 5652.124 MHz : -2.065 dBm T2 : 5727.876 MHz : -6.035 dBm OBW : 75.752 MHz	Measured 26 dB Bandwidth: 80.160 MHz Measured 99% Bandwidth: 75.752 MHz

[Back to the Matrix](#)

This test report may be reproduced in full only. The document may only be updated by MiCOM Labs personnel. Any changes will be noted in the Document History section of the report.



Title: Aruba Networks APIN0214, APIN0215
To: FCC 47 CFR Part 15.407 & IC RSS-210
Serial #: ARUB179-U8 Rev B
Issue Date: 2nd September 2014
Page: 222 of 330



26 dB & 99% BANDWIDTH

Variante: 802.11ac-80, Channel: 5690.00 MHz, Chain b, Temp: Ambient, Voltage: 12 Vdc

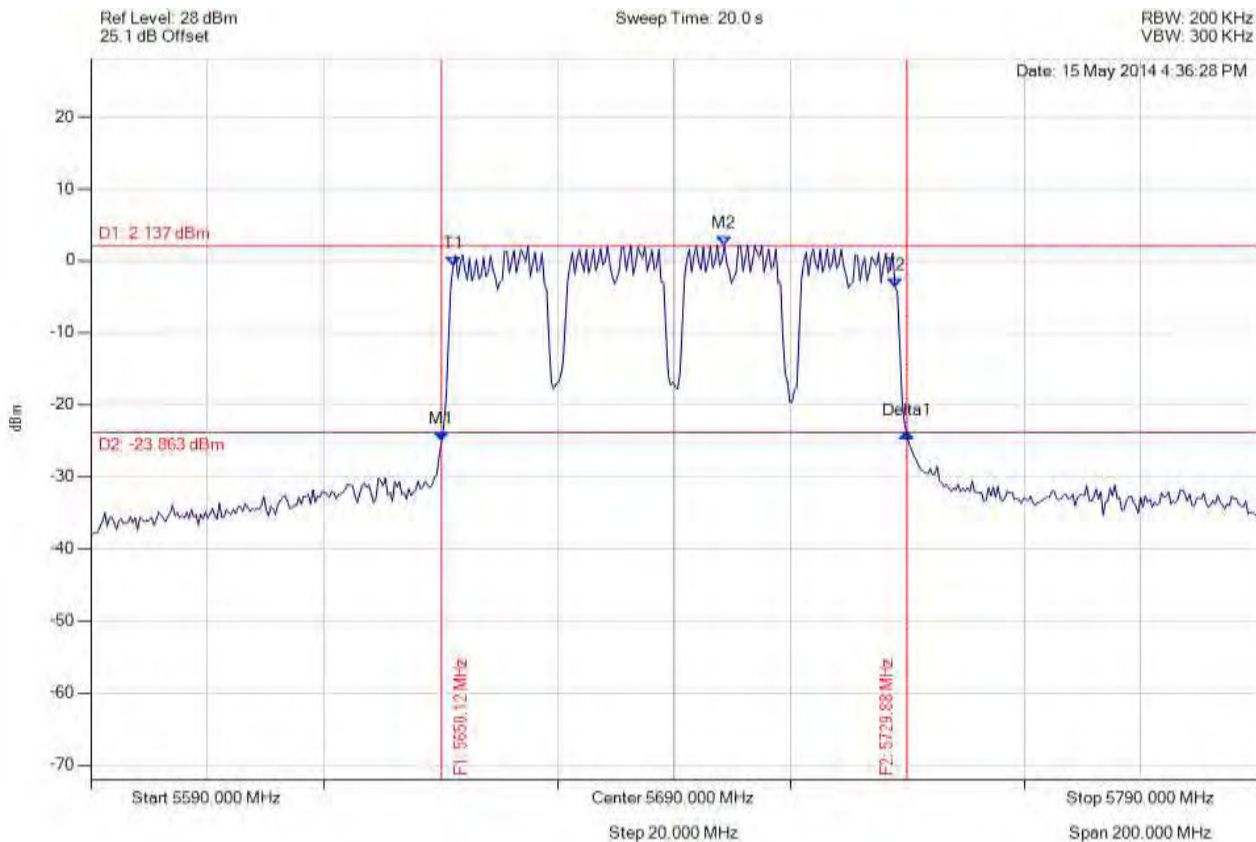

Analyser Setup	Marker : Frequency : Amplitude	Test Results
Detector = MAX PEAK Sweep Count = 0 RF Atten (dB) = 20 Trace Mode = VIEW	M1 : 5650.120 MHz : -25.128 dBm M2 : 5698.617 MHz : 2.137 dBm Delta1 : 79.760 MHz : 1.255 dB T1 : 5652.124 MHz : -0.708 dBm T2 : 5727.876 MHz : -3.635 dBm OBW : 75.752 MHz	Measured 26 dB Bandwidth: 79.760 MHz Measured 99% Bandwidth: 75.752 MHz

[Back to the Matrix](#)

This test report may be reproduced in full only. The document may only be updated by MiCOM Labs personnel. Any changes will be noted in the Document History section of the report.



Title: Aruba Networks APIN0214, APIN0215
To: FCC 47 CFR Part 15.407 & IC RSS-210
Serial #: ARUB179-U8 Rev B
Issue Date: 2nd September 2014
Page: 223 of 330



26 dB & 99% BANDWIDTH

Variant: 802.11ac-80, Channel: 5690.00 MHz, Chain c, Temp: Ambient, Voltage: 12 Vdc

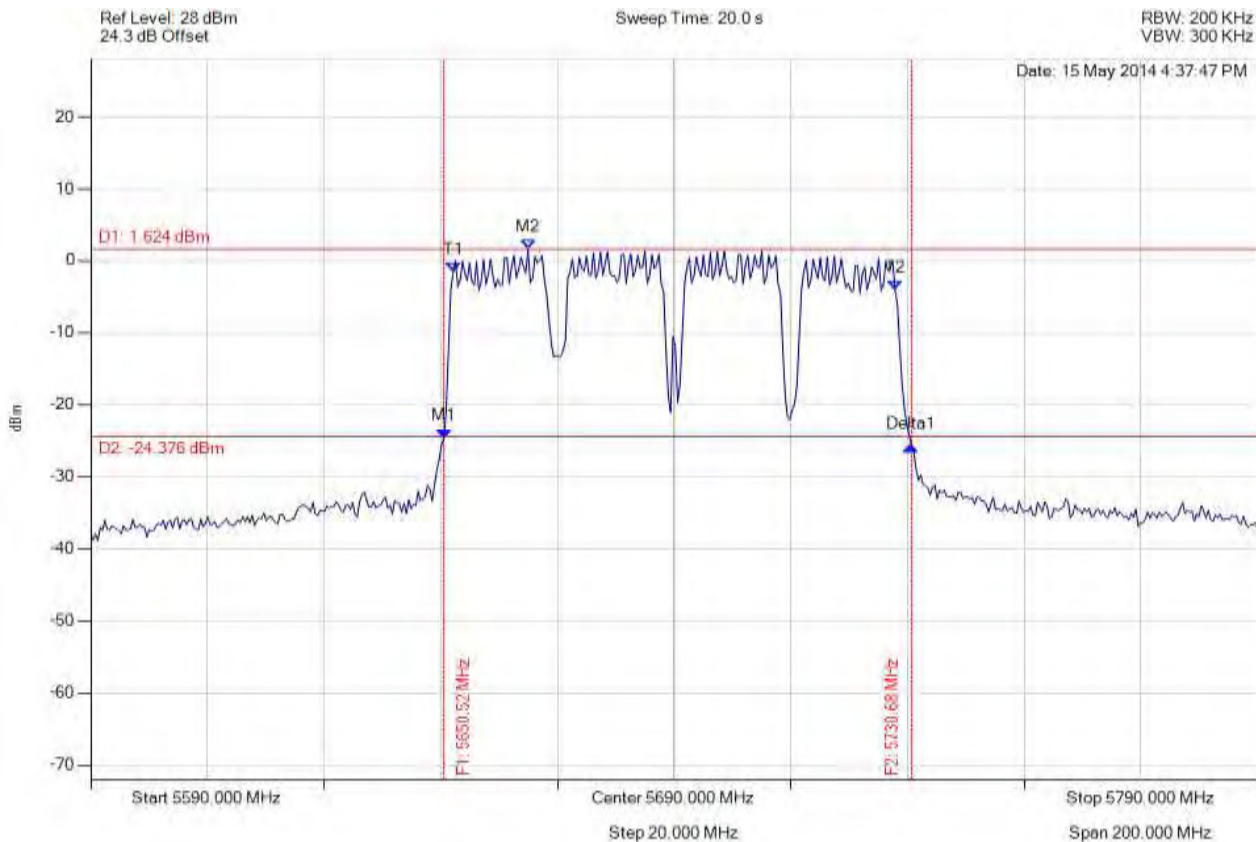

Analyser Setup	Marker : Frequency : Amplitude	Test Results
Detector = MAX PEAK Sweep Count = 0 RF Atten (dB) = 20 Trace Mode = VIEW	M1 : 5650.521 MHz : -24.633 dBm M2 : 5664.950 MHz : 1.624 dBm Delta1 : 80.160 MHz : -1.035 dB T1 : 5652.124 MHz : -1.512 dBm T2 : 5727.876 MHz : -4.068 dBm OBW : 75.752 MHz	Measured 26 dB Bandwidth: 80.160 MHz Measured 99% Bandwidth: 75.752 MHz

[Back to the Matrix](#)

This test report may be reproduced in full only. The document may only be updated by MiCOM Labs personnel. Any changes will be noted in the Document History section of the report.



Title: Aruba Networks APIN0214, APIN0215
To: FCC 47 CFR Part 15.407 & IC RSS-210
Serial #: ARUB179-U8 Rev B
Issue Date: 2nd September 2014
Page: 224 of 330



26 dB & 99% BANDWIDTH

Variant: 802.11n HT-20, Channel: 5500.00 MHz, Chain a, Temp: Ambient, Voltage: 12 Vdc

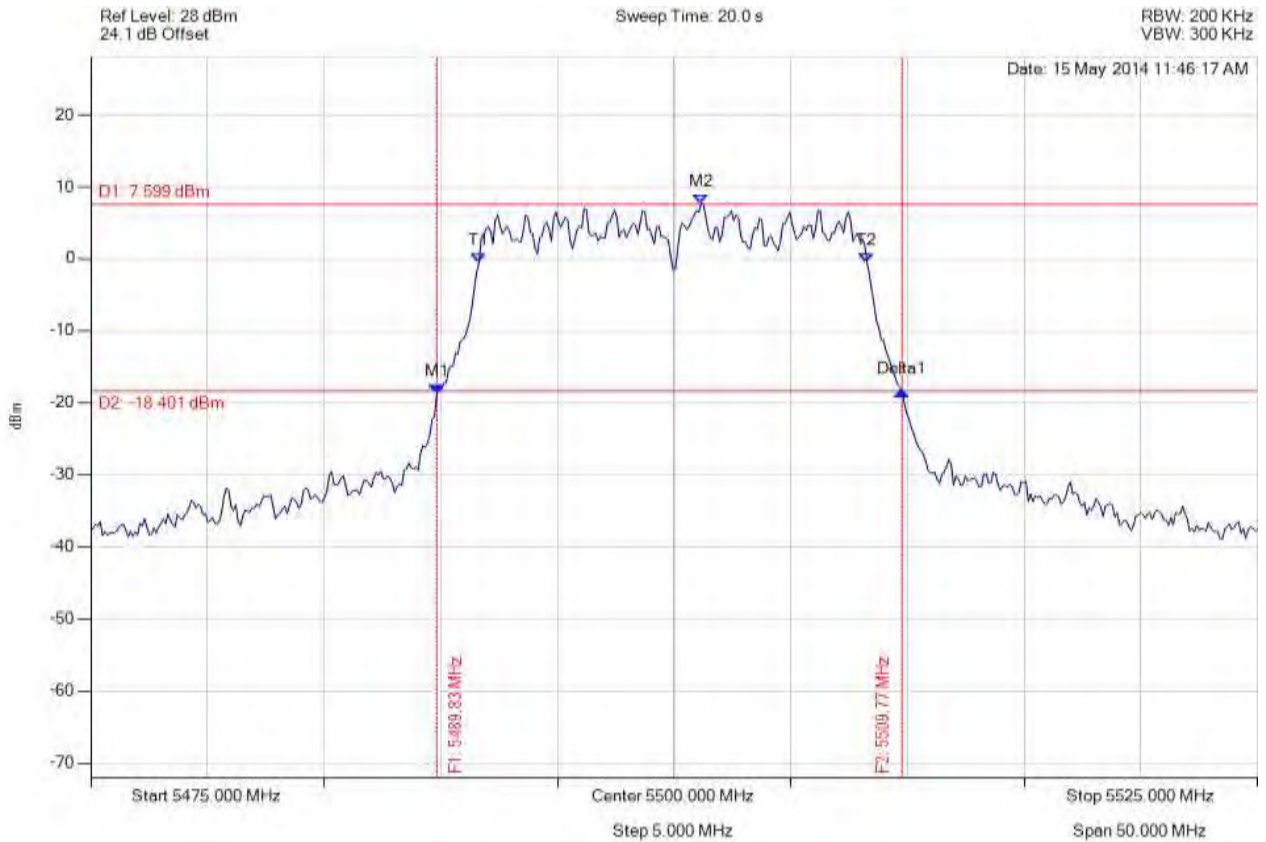

Analyser Setup	Marker : Frequency : Amplitude	Test Results
Detector = MAX PEAK Sweep Count = 0 RF Atten (dB) = 20 Trace Mode = VIEW	M1 : 5489.830 MHz : -18.650 dBm M2 : 5501.152 MHz : 7.599 dBm Delta1 : 19.940 MHz : 0.224 dB T1 : 5491.633 MHz : -0.586 dBm T2 : 5508.267 MHz : -0.470 dBm OBW : 16.633 MHz	Measured 26 dB Bandwidth: 19.940 MHz Measured 99% Bandwidth: 16.633 MHz

[Back to the Matrix](#)

This test report may be reproduced in full only. The document may only be updated by MiCOM Labs personnel. Any changes will be noted in the Document History section of the report.



Title: Aruba Networks APIN0214, APIN0215
To: FCC 47 CFR Part 15.407 & IC RSS-210
Serial #: ARUB179-U8 Rev B
Issue Date: 2nd September 2014
Page: 225 of 330



26 dB & 99% BANDWIDTH

Variant: 802.11n HT-20, Channel: 5500.00 MHz, Chain b, Temp: Ambient, Voltage: 12 Vdc

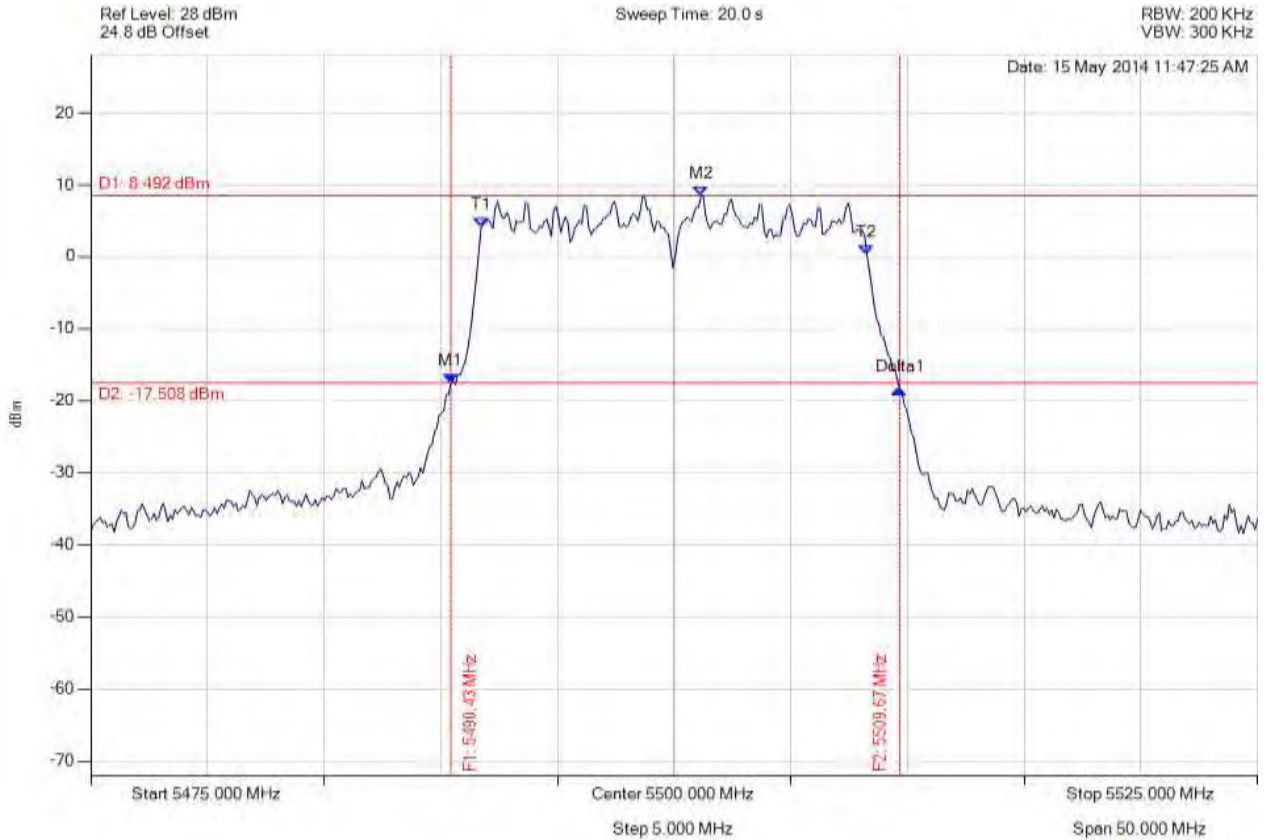

Analyser Setup	Marker : Frequency : Amplitude	Test Results
Detector = MAX PEAK Sweep Count = 0 RF Atten (dB) = 20 Trace Mode = VIEW	M1 : 5490.431 MHz : -17.582 dBm M2 : 5501.152 MHz : 8.492 dBm Delta1 : 19.238 MHz : -0.785 dB T1 : 5491.733 MHz : 4.114 dBm T2 : 5508.267 MHz : 0.239 dBm OBW : 16.533 MHz	Measured 26 dB Bandwidth: 19.238 MHz Measured 99% Bandwidth: 16.533 MHz

[Back to the Matrix](#)

This test report may be reproduced in full only. The document may only be updated by MiCOM Labs personnel. Any changes will be noted in the Document History section of the report.



Title: Aruba Networks APIN0214, APIN0215
To: FCC 47 CFR Part 15.407 & IC RSS-210
Serial #: ARUB179-U8 Rev B
Issue Date: 2nd September 2014
Page: 226 of 330



26 dB & 99% BANDWIDTH

Variant: 802.11n HT-20, Channel: 5500.00 MHz, Chain c, Temp: Ambient, Voltage: 12 Vdc

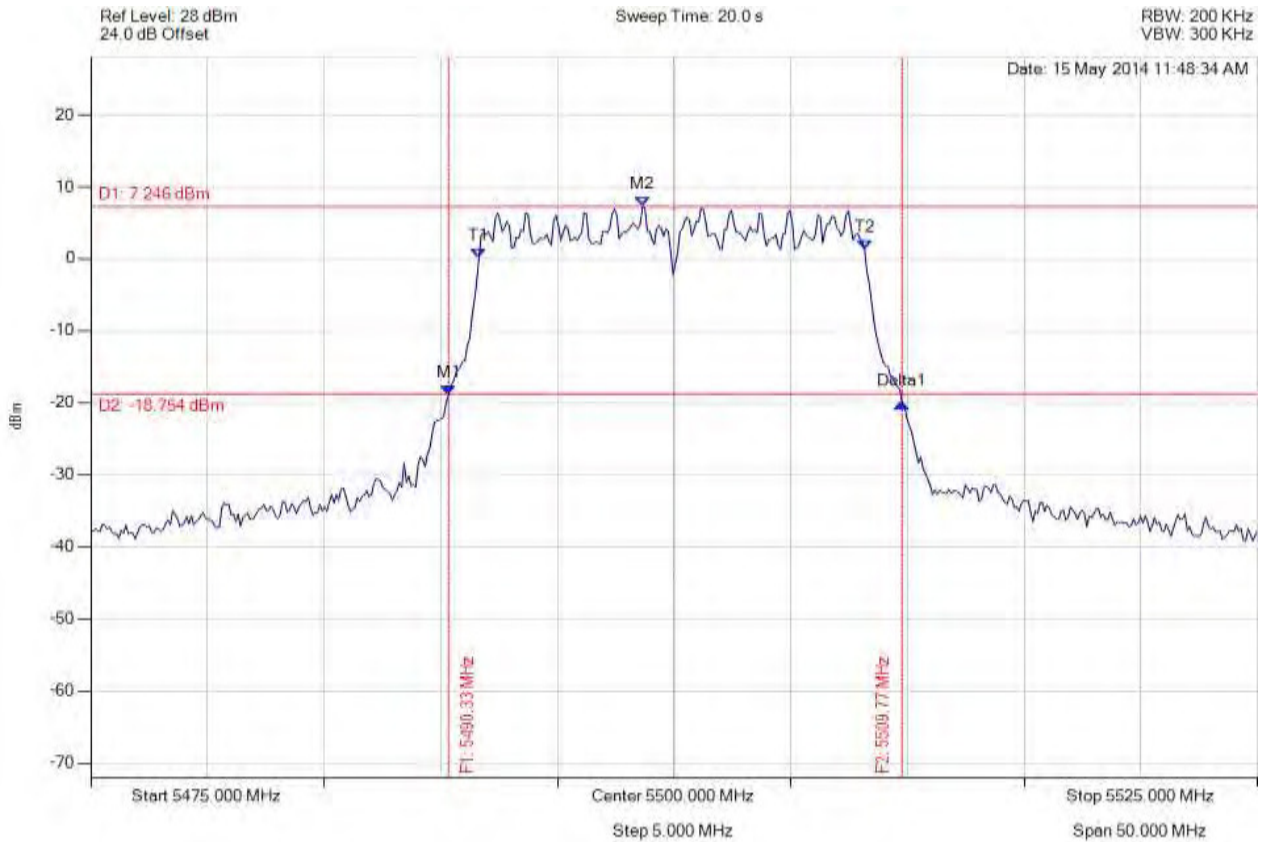

Analyser Setup	Marker : Frequency : Amplitude	Test Results
Detector = MAX PEAK Sweep Count = 0 RF Atten (dB) = 20 Trace Mode = VIEW	M1 : 5490.331 MHz : -18.904 dBm M2 : 5498.647 MHz : 7.246 dBm Delta1 : 19.439 MHz : -1.076 dB T1 : 5491.633 MHz : 0.060 dBm T2 : 5508.166 MHz : 1.289 dBm OBW : 16.533 MHz	Measured 26 dB Bandwidth: 19.439 MHz Measured 99% Bandwidth: 16.533 MHz

[Back to the Matrix](#)

This test report may be reproduced in full only. The document may only be updated by MiCOM Labs personnel. Any changes will be noted in the Document History section of the report.



Title: Aruba Networks APIN0214, APIN0215
To: FCC 47 CFR Part 15.407 & IC RSS-210
Serial #: ARUB179-U8 Rev B
Issue Date: 2nd September 2014
Page: 227 of 330



26 dB & 99% BANDWIDTH

Variant: 802.11n HT-20, Channel: 5580.00 MHz, Chain a, Temp: Ambient, Voltage: 12 Vdc

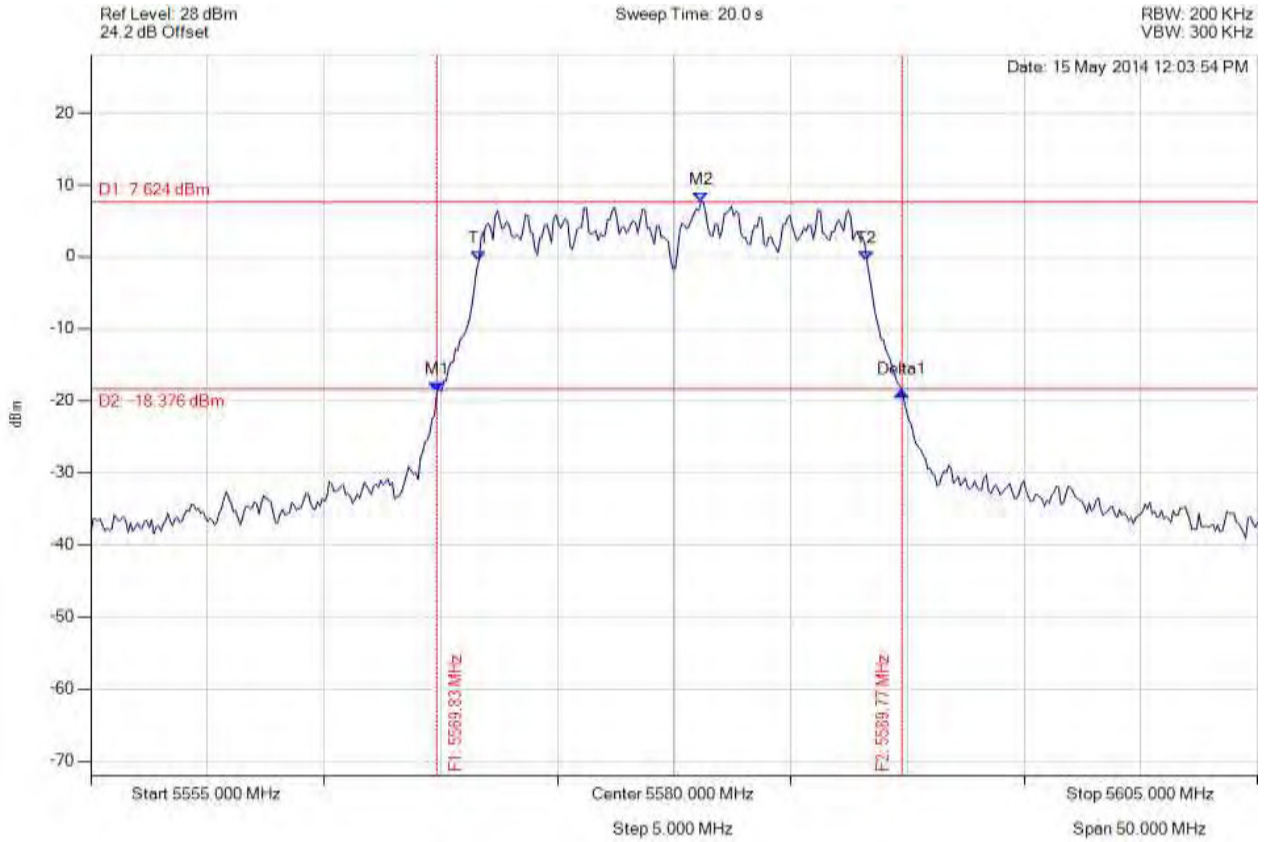

Analyser Setup	Marker : Frequency : Amplitude	Test Results
Detector = MAX PEAK Sweep Count = 0 RF Atten (dB) = 20 Trace Mode = VIEW	M1 : 5569.830 MHz : -18.768 dBm M2 : 5581.152 MHz : 7.624 dBm Delta1 : 19.940 MHz : 0.104 dB T1 : 5571.633 MHz : -0.505 dBm T2 : 5588.267 MHz : -0.556 dBm OBW : 16.633 MHz	Measured 26 dB Bandwidth: 19.940 MHz Measured 99% Bandwidth: 16.633 MHz

[Back to the Matrix](#)

This test report may be reproduced in full only. The document may only be updated by MiCOM Labs personnel. Any changes will be noted in the Document History section of the report.



Title: Aruba Networks APIN0214, APIN0215
To: FCC 47 CFR Part 15.407 & IC RSS-210
Serial #: ARUB179-U8 Rev B
Issue Date: 2nd September 2014
Page: 228 of 330



26 dB & 99% BANDWIDTH

Variant: 802.11n HT-20, Channel: 5580.00 MHz, Chain b, Temp: Ambient, Voltage: 12 Vdc

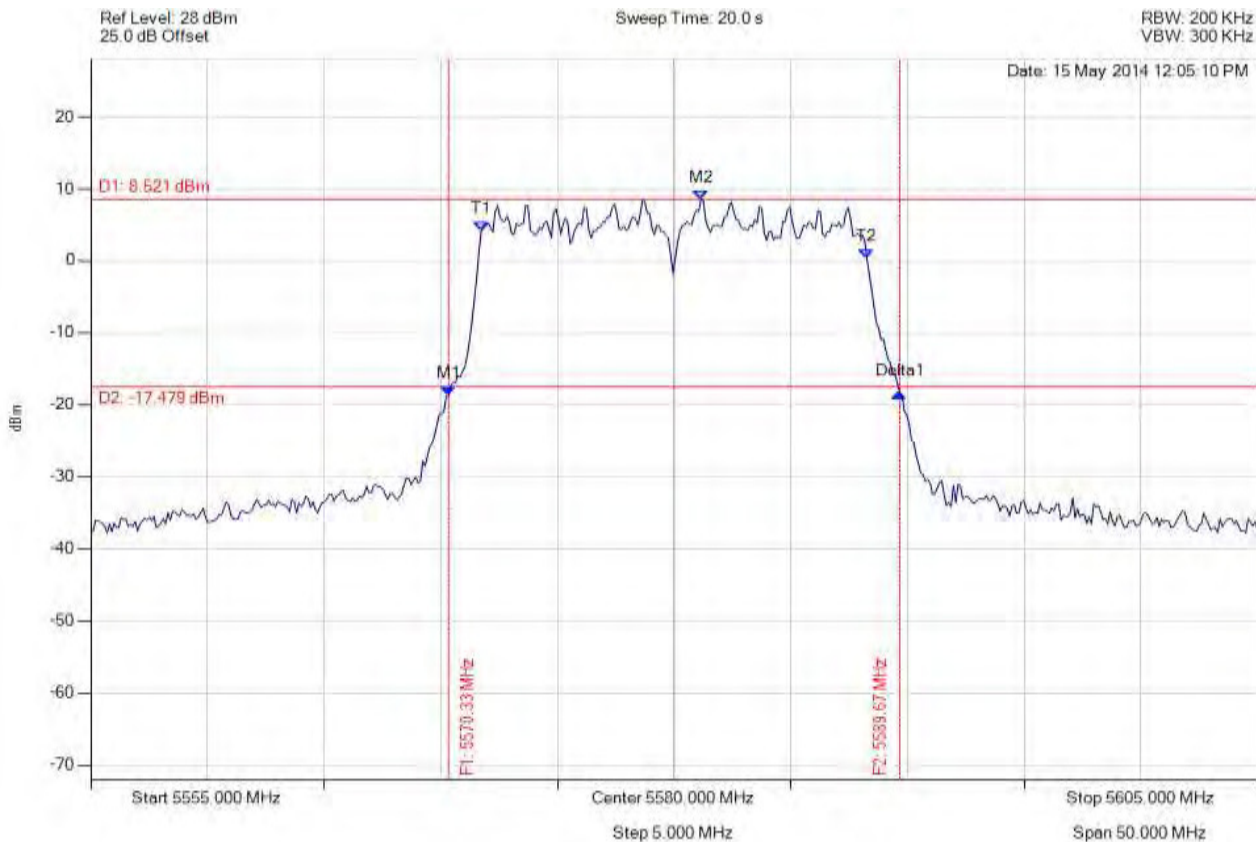

Analyser Setup	Marker : Frequency : Amplitude	Test Results
Detector = MAX PEAK Sweep Count = 0 RF Atten (dB) = 20 Trace Mode = VIEW	M1 : 5570.331 MHz : -18.729 dBm M2 : 5581.152 MHz : 8.521 dBm Delta1 : 19.339 MHz : 0.346 dB T1 : 5571.733 MHz : 4.193 dBm T2 : 5588.267 MHz : 0.241 dBm OBW : 16.533 MHz	Measured 26 dB Bandwidth : 19.339 MHz Measured 99% Bandwidth: 16.533 MHz

[Back to the Matrix](#)

This test report may be reproduced in full only. The document may only be updated by MiCOM Labs personnel. Any changes will be noted in the Document History section of the report.



Title: Aruba Networks APIN0214, APIN0215
To: FCC 47 CFR Part 15.407 & IC RSS-210
Serial #: ARUB179-U8 Rev B
Issue Date: 2nd September 2014
Page: 229 of 330



26 dB & 99% BANDWIDTH

Variant: 802.11n HT-20, Channel: 5580.00 MHz, Chain c, Temp: Ambient, Voltage: 12 Vdc

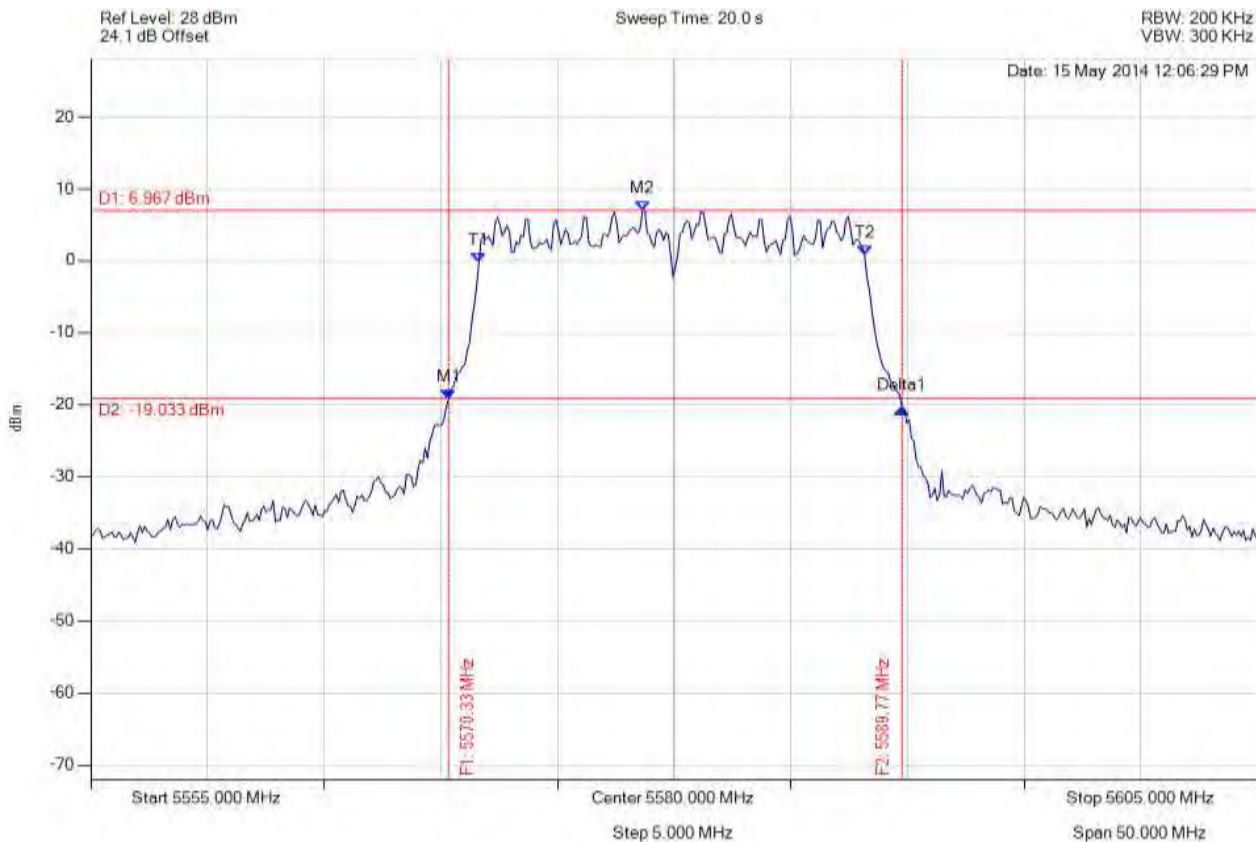

Analyser Setup	Marker : Frequency : Amplitude	Test Results
Detector = MAX PEAK Sweep Count = 0 RF Atten (dB) = 20 Trace Mode = VIEW	M1 : 5570.331 MHz : -19.203 dBm M2 : 5578.647 MHz : 6.967 dBm Delta1 : 19.439 MHz : -1.261 dB T1 : 5571.633 MHz : -0.200 dBm T2 : 5588.166 MHz : 0.778 dBm OBW : 16.533 MHz	Measured 26 dB Bandwidth: 19.439 MHz Measured 99% Bandwidth: 16.533 MHz

[Back to the Matrix](#)

This test report may be reproduced in full only. The document may only be updated by MiCOM Labs personnel. Any changes will be noted in the Document History section of the report.



Title: Aruba Networks APIN0214, APIN0215
To: FCC 47 CFR Part 15.407 & IC RSS-210
Serial #: ARUB179-U8 Rev B
Issue Date: 2nd September 2014
Page: 230 of 330



26 dB & 99% BANDWIDTH

Variant: 802.11n HT-20, Channel: 5720.00 MHz, Chain a, Temp: Ambient, Voltage: 12 Vdc

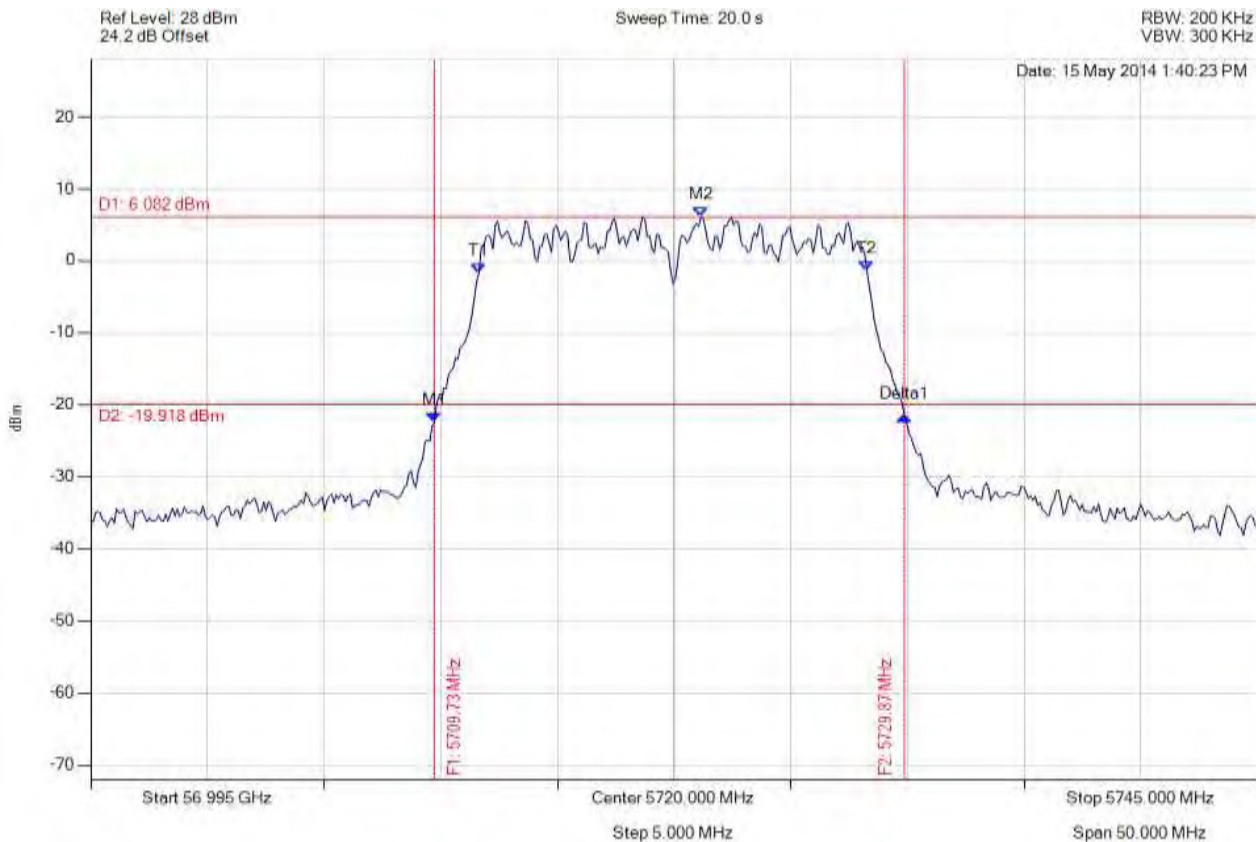

Analyser Setup	Marker : Frequency : Amplitude	Test Results
Detector = MAX PEAK Sweep Count = 0 RF Atten (dB) = 20 Trace Mode = VIEW	M1 : 5709.729 MHz : -22.323 dBm M2 : 5721.152 MHz : 6.082 dBm Delta1 : 20.140 MHz : 0.842 dB T1 : 5711.633 MHz : -1.733 dBm T2 : 5728.267 MHz : -1.402 dBm OBW : 16.633 MHz	Channel Frequency: 5720.00 MHz

[Back to the Matrix](#)

This test report may be reproduced in full only. The document may only be updated by MiCOM Labs personnel. Any changes will be noted in the Document History section of the report.



26 dB & 99% BANDWIDTH

Variant: 802.11n HT-20, Channel: 5720.00 MHz, Chain b, Temp: Ambient, Voltage: 12 Vdc

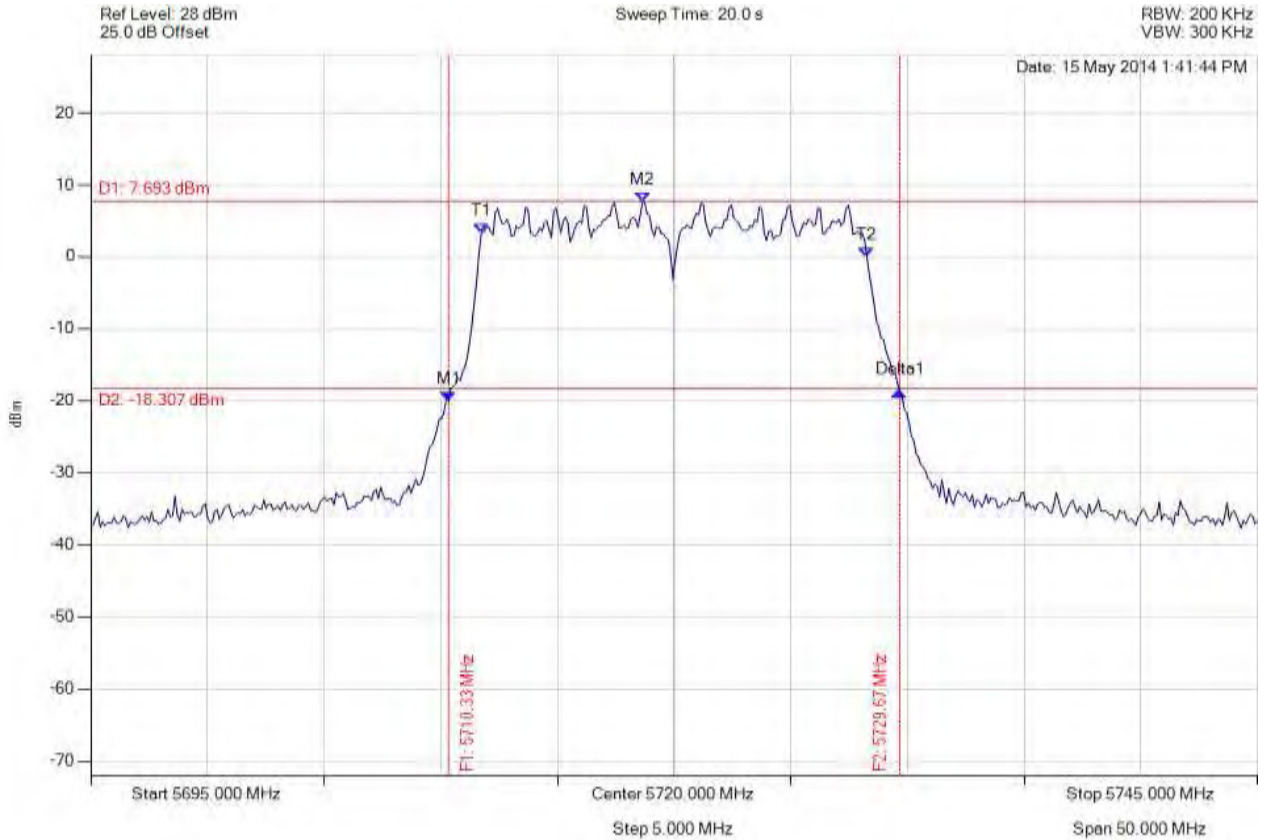

Analyser Setup	Marker : Frequency : Amplitude	Test Results
Detector = MAX PEAK Sweep Count = 0 RF Atten (dB) = 20 Trace Mode = VIEW	ERROR!!! MULTIPLE TEST RESULTS MATCHES...	Measured 26 dB Bandwidth: 19.339 MHz Measured 99% Bandwidth: 16.533 MHz ERROR!!! MULTIPLE TEST RESULTS MATCHES...

[Back to the Matrix](#)

This test report may be reproduced in full only. The document may only be updated by MiCOM Labs personnel. Any changes will be noted in the Document History section of the report.



Title: Aruba Networks APIN0214, APIN0215
To: FCC 47 CFR Part 15.407 & IC RSS-210
Serial #: ARUB179-U8 Rev B
Issue Date: 2nd September 2014
Page: 232 of 330



26 dB & 99% BANDWIDTH

Variant: 802.11n HT-20, Channel: 5720.00 MHz, Chain c, Temp: Ambient, Voltage: 12 Vdc

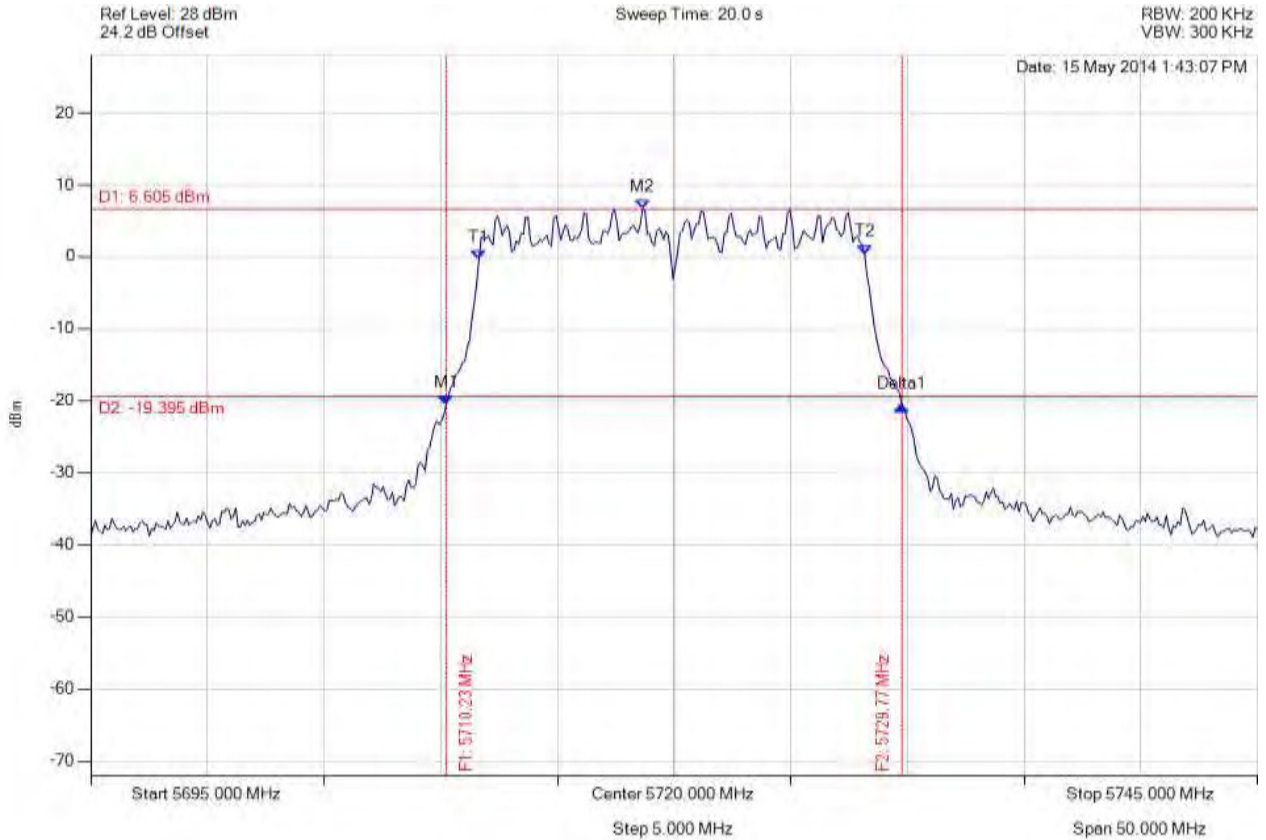

Analyser Setup	Marker : Frequency : Amplitude	Test Results
Detector = MAX PEAK Sweep Count = 0 RF Atten (dB) = 20 Trace Mode = VIEW	M1 : 5710.230 MHz : -20.489 dBm M2 : 5718.647 MHz : 6.605 dBm Delta1 : 19.539 MHz : -0.275 dB T1 : 5711.633 MHz : -0.442 dBm T2 : 5728.166 MHz : 0.382 dBm OBW : 16.533 MHz	Measured 26 dB Bandwidth: 19.539 MHz Measured 99% Bandwidth: 16.533 MHz

[Back to the Matrix](#)

This test report may be reproduced in full only. The document may only be updated by MiCOM Labs personnel. Any changes will be noted in the Document History section of the report.



Title: Aruba Networks APIN0214, APIN0215
To: FCC 47 CFR Part 15.407 & IC RSS-210
Serial #: ARUB179-U8 Rev B
Issue Date: 2nd September 2014
Page: 233 of 330



26 dB & 99% BANDWIDTH

Variant: 802.11n HT-40, Channel: 5510.00 MHz, Chain a, Temp: Ambient, Voltage: 12 Vdc

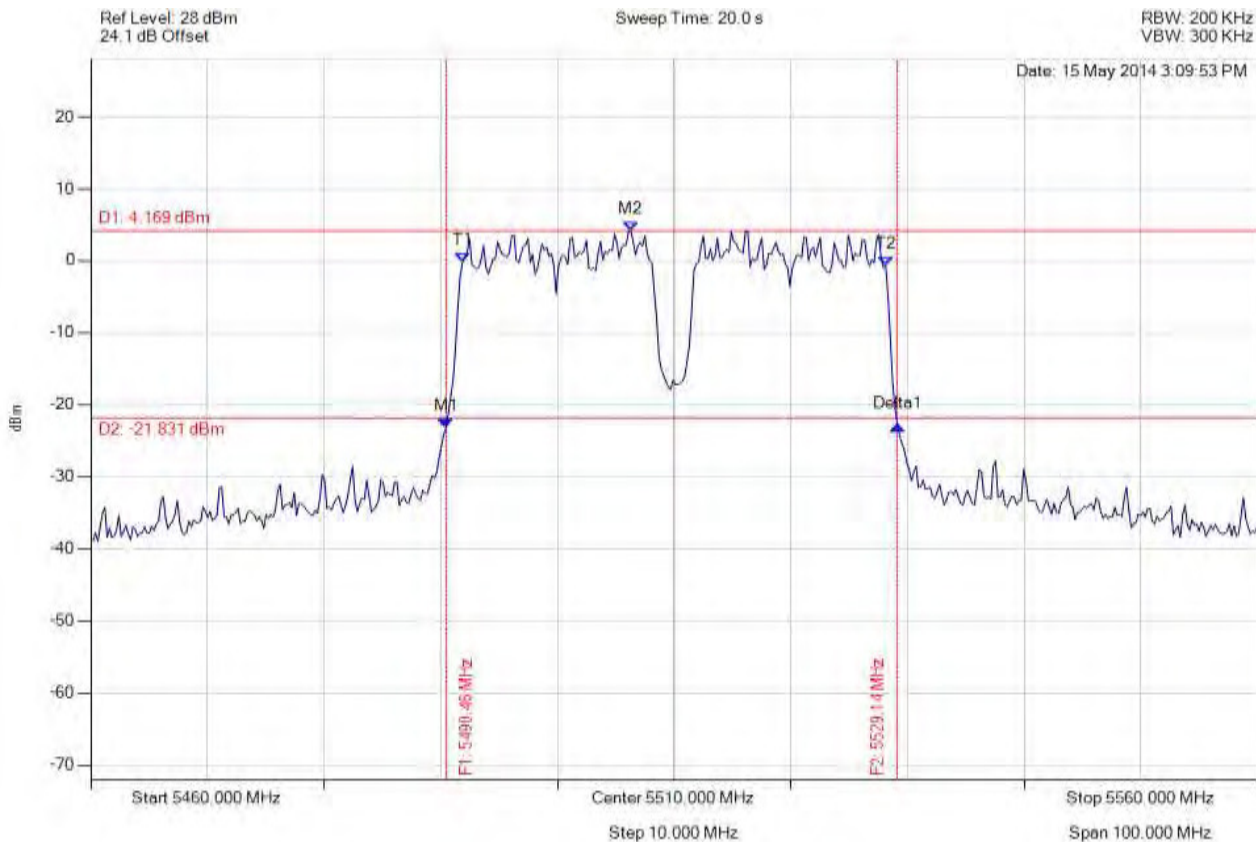

Analyser Setup	Marker : Frequency : Amplitude	Test Results
Detector = MAX PEAK Sweep Count = 0 RF Atten (dB) = 20 Trace Mode = VIEW	M1 : 5490.461 MHz : -23.277 dBm M2 : 5506.293 MHz : 4.169 dBm Delta1 : 38.677 MHz : 0.397 dB T1 : 5491.864 MHz : -0.145 dBm T2 : 5528.136 MHz : -0.641 dBm OBW : 36.273 MHz	Measured 26 dB Bandwidth : 38.677 MHz Measured 99% Bandwidth : 36.273 MHz

[Back to the Matrix](#)

This test report may be reproduced in full only. The document may only be updated by MiCOM Labs personnel. Any changes will be noted in the Document History section of the report.



Title: Aruba Networks APIN0214, APIN0215
To: FCC 47 CFR Part 15.407 & IC RSS-210
Serial #: ARUB179-U8 Rev B
Issue Date: 2nd September 2014
Page: 234 of 330



26 dB & 99% BANDWIDTH

Variant: 802.11n HT-40, Channel: 5510.00 MHz, Chain b, Temp: Ambient, Voltage: 12 Vdc

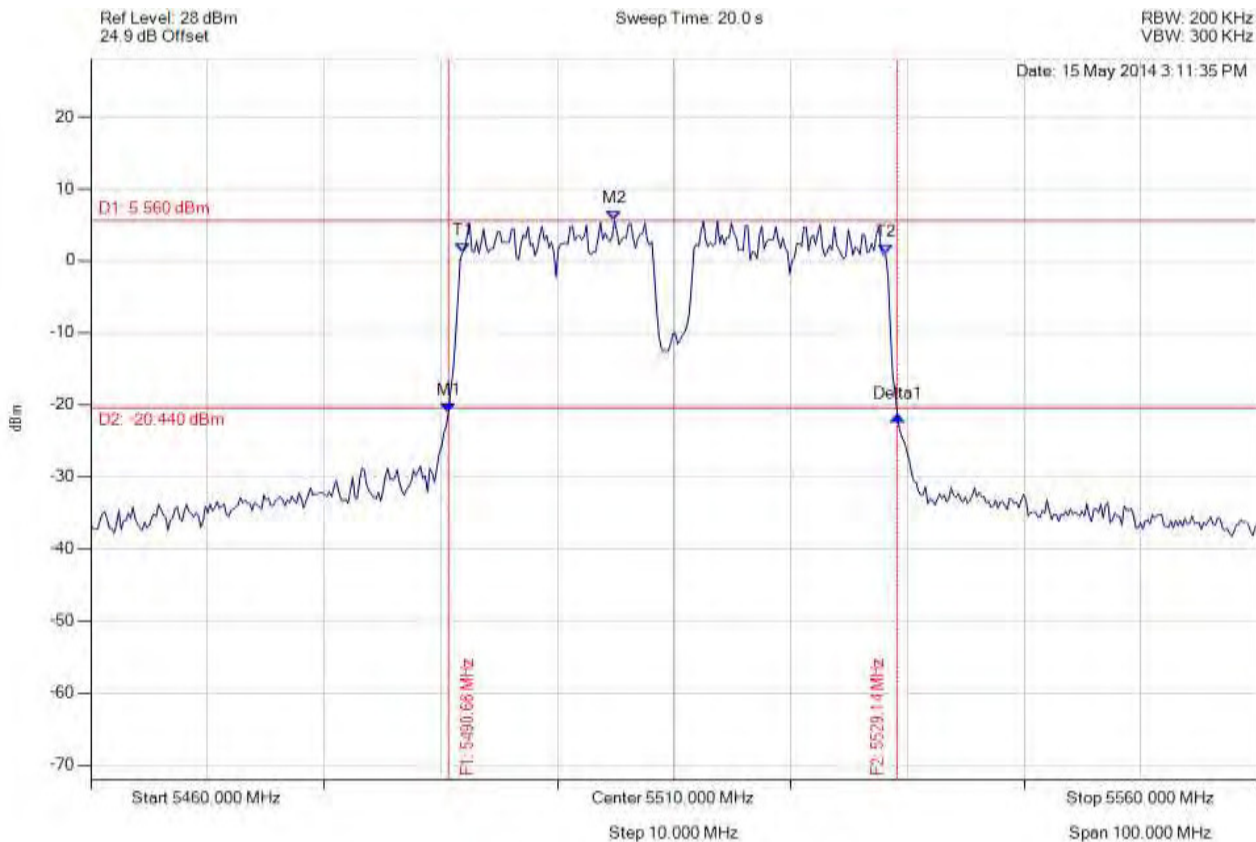

Analyser Setup	Marker : Frequency : Amplitude	Test Results
Detector = MAX PEAK Sweep Count = 0 RF Atten (dB) = 20 Trace Mode = VIEW	M1 : 5490.661 MHz : -20.999 dBm M2 : 5504.890 MHz : 5.560 dBm Delta1 : 38.477 MHz : -0.527 dB T1 : 5491.864 MHz : 1.161 dBm T2 : 5528.136 MHz : 0.959 dBm OBW : 36.273 MHz	Measured 26 dB Bandwidth: 38.477 MHz Measured 99% Bandwidth: 36.273 MHz

[Back to the Matrix](#)

This test report may be reproduced in full only. The document may only be updated by MiCOM Labs personnel. Any changes will be noted in the Document History section of the report.



Title: Aruba Networks APIN0214, APIN0215
To: FCC 47 CFR Part 15.407 & IC RSS-210
Serial #: ARUB179-U8 Rev B
Issue Date: 2nd September 2014
Page: 235 of 330



26 dB & 99% BANDWIDTH

Variant: 802.11n HT-40, Channel: 5510.00 MHz, Chain c, Temp: Ambient, Voltage: 12 Vdc

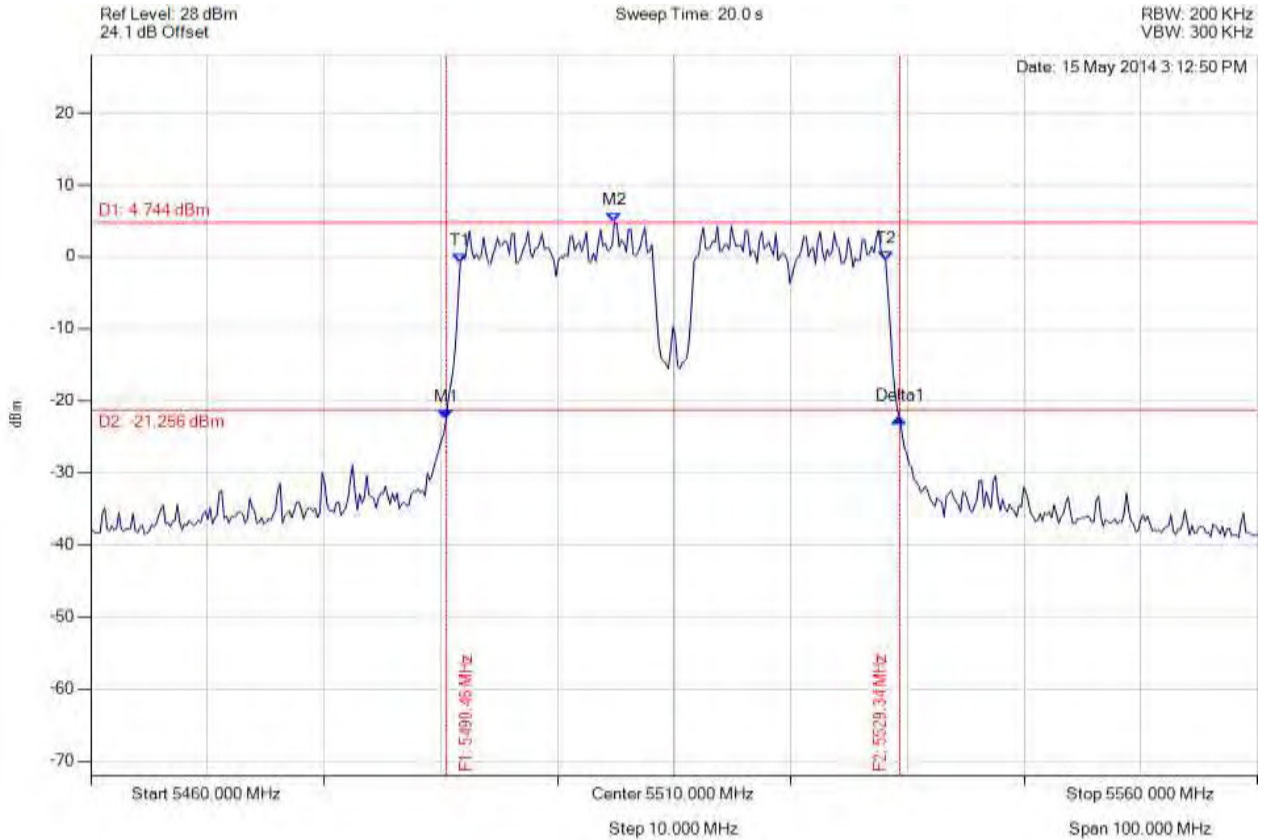

Analyser Setup	Marker : Frequency : Amplitude	Test Results
Detector = MAX PEAK Sweep Count = 0 RF Atten (dB) = 20 Trace Mode = VIEW	M1 : 5490.461 MHz : -22.543 dBm M2 : 5504.890 MHz : 4.744 dBm Delta1 : 38.878 MHz : 0.081 dB T1 : 5491.663 MHz : -0.908 dBm T2 : 5528.136 MHz : -0.586 dBm OBW : 36.473 MHz	Measured 26 dB Bandwidth: 38.878 MHz Measured 99% Bandwidth: 36.473 MHz

[Back to the Matrix](#)

This test report may be reproduced in full only. The document may only be updated by MiCOM Labs personnel. Any changes will be noted in the Document History section of the report.



Title: Aruba Networks APIN0214, APIN0215
To: FCC 47 CFR Part 15.407 & IC RSS-210
Serial #: ARUB179-U8 Rev B
Issue Date: 2nd September 2014
Page: 236 of 330



26 dB & 99% BANDWIDTH

Variant: 802.11n HT-40, Channel: 5550.00 MHz, Chain a, Temp: Ambient, Voltage: 12 Vdc

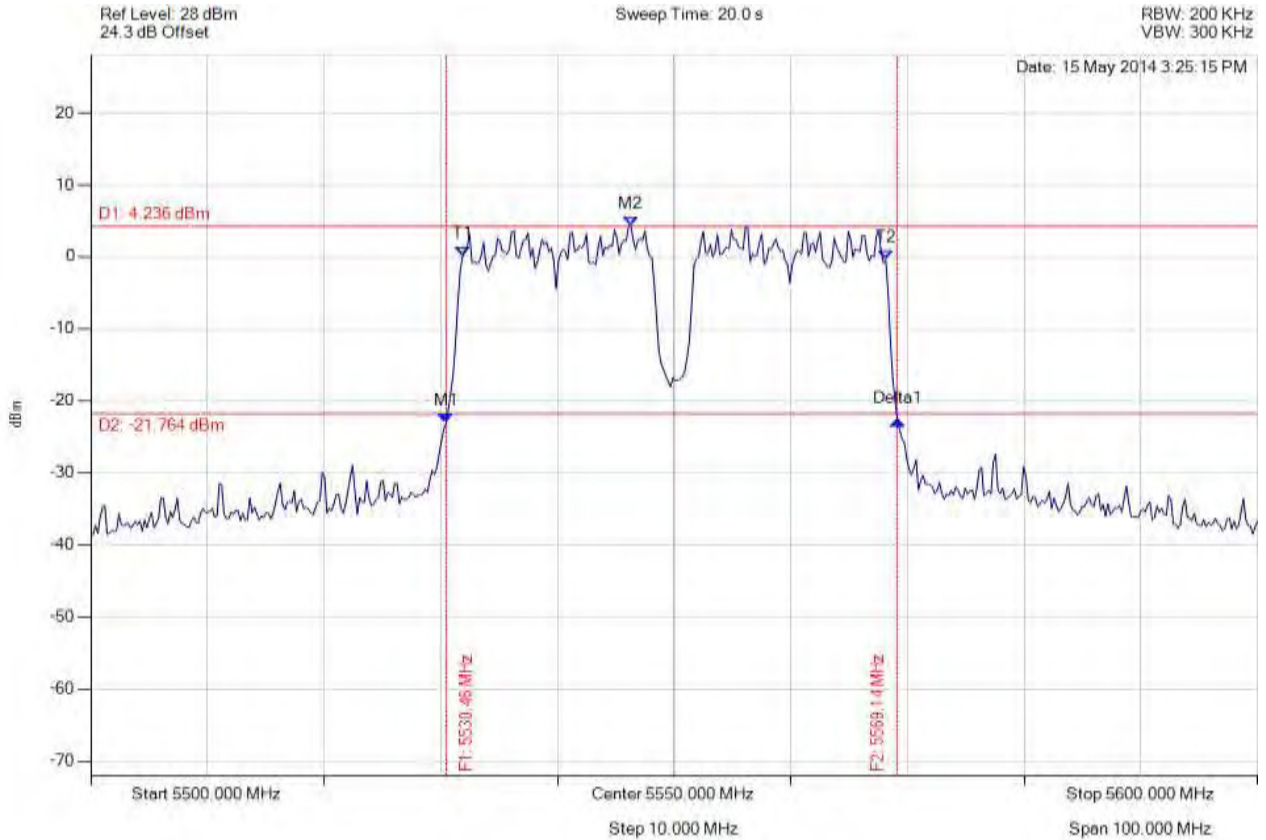

Analyser Setup	Marker : Frequency : Amplitude	Test Results
Detector = MAX PEAK Sweep Count = 0 RF Atten (dB) = 20 Trace Mode = VIEW	M1 : 5530.461 MHz : -23.100 dBm M2 : 5546.293 MHz : 4.236 dBm Delta1 : 38.677 MHz : 0.407 dB T1 : 5531.864 MHz : 0.075 dBm T2 : 5568.136 MHz : -0.391 dBm OBW : 36.273 MHz	Measured 26 dB Bandwidth: 38.677 MHz Measured 99% Bandwidth: 36.273 MHz

[Back to the Matrix](#)

This test report may be reproduced in full only. The document may only be updated by MiCOM Labs personnel. Any changes will be noted in the Document History section of the report.



Title: Aruba Networks APIN0214, APIN0215
To: FCC 47 CFR Part 15.407 & IC RSS-210
Serial #: ARUB179-U8 Rev B
Issue Date: 2nd September 2014
Page: 237 of 330



26 dB & 99% BANDWIDTH

Variant: 802.11n HT-40, Channel: 5550.00 MHz, Chain b, Temp: Ambient, Voltage: 12 Vdc

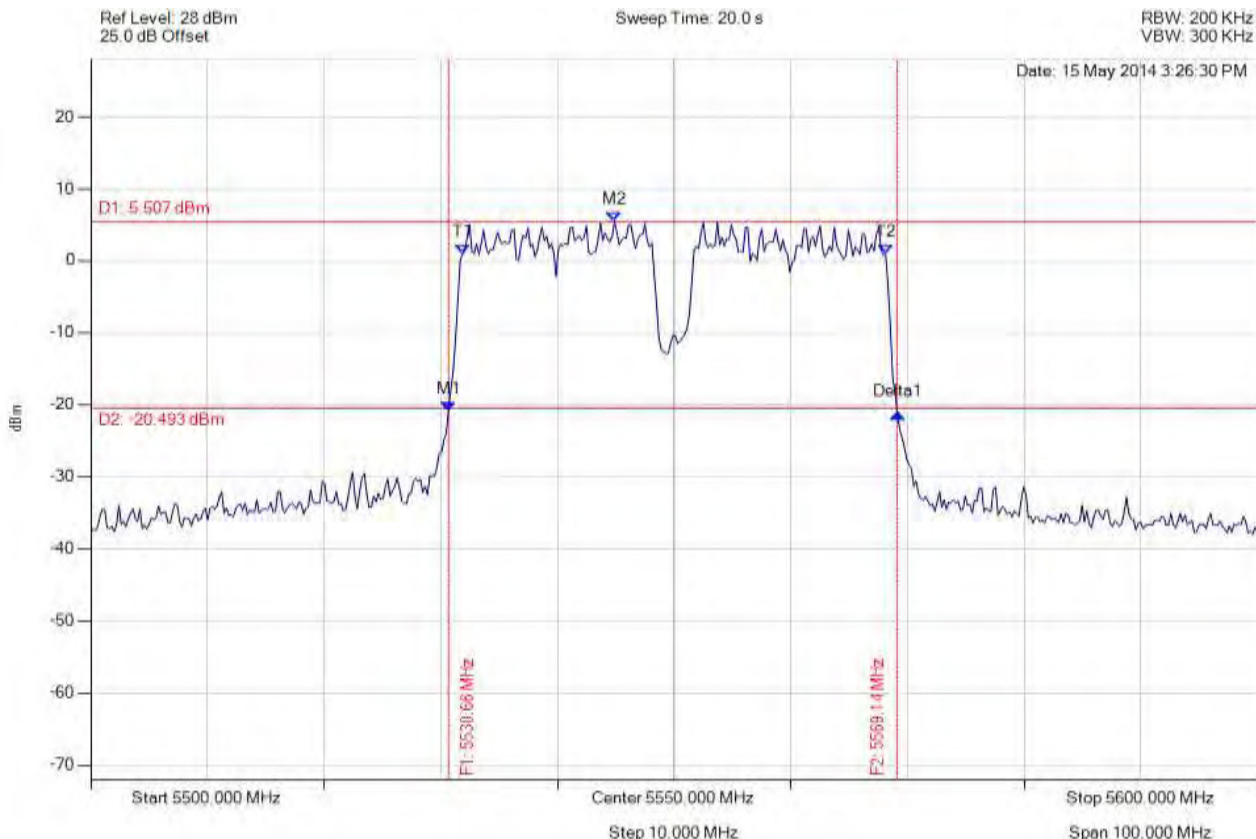

Analyser Setup	Marker : Frequency : Amplitude	Test Results
Detector = MAX PEAK Sweep Count = 0 RF Atten (dB) = 20 Trace Mode = VIEW	M1 : 5530.661 MHz : -20.826 dBm M2 : 5544.890 MHz : 5.507 dBm Delta1 : 38.477 MHz : -0.397 dB T1 : 5531.864 MHz : 0.963 dBm T2 : 5568.136 MHz : 0.913 dBm OBW : 36.273 MHz	Measured 26 dB Bandwidth: 38.477 MHz Measured 99% Bandwidth: 36.273 MHz

[Back to the Matrix](#)

This test report may be reproduced in full only. The document may only be updated by MiCOM Labs personnel. Any changes will be noted in the Document History section of the report.



Title: Aruba Networks APIN0214, APIN0215
To: FCC 47 CFR Part 15.407 & IC RSS-210
Serial #: ARUB179-U8 Rev B
Issue Date: 2nd September 2014
Page: 238 of 330



26 dB & 99% BANDWIDTH

Variant: 802.11n HT-40, Channel: 5550.00 MHz, Chain c, Temp: Ambient, Voltage: 12 Vdc

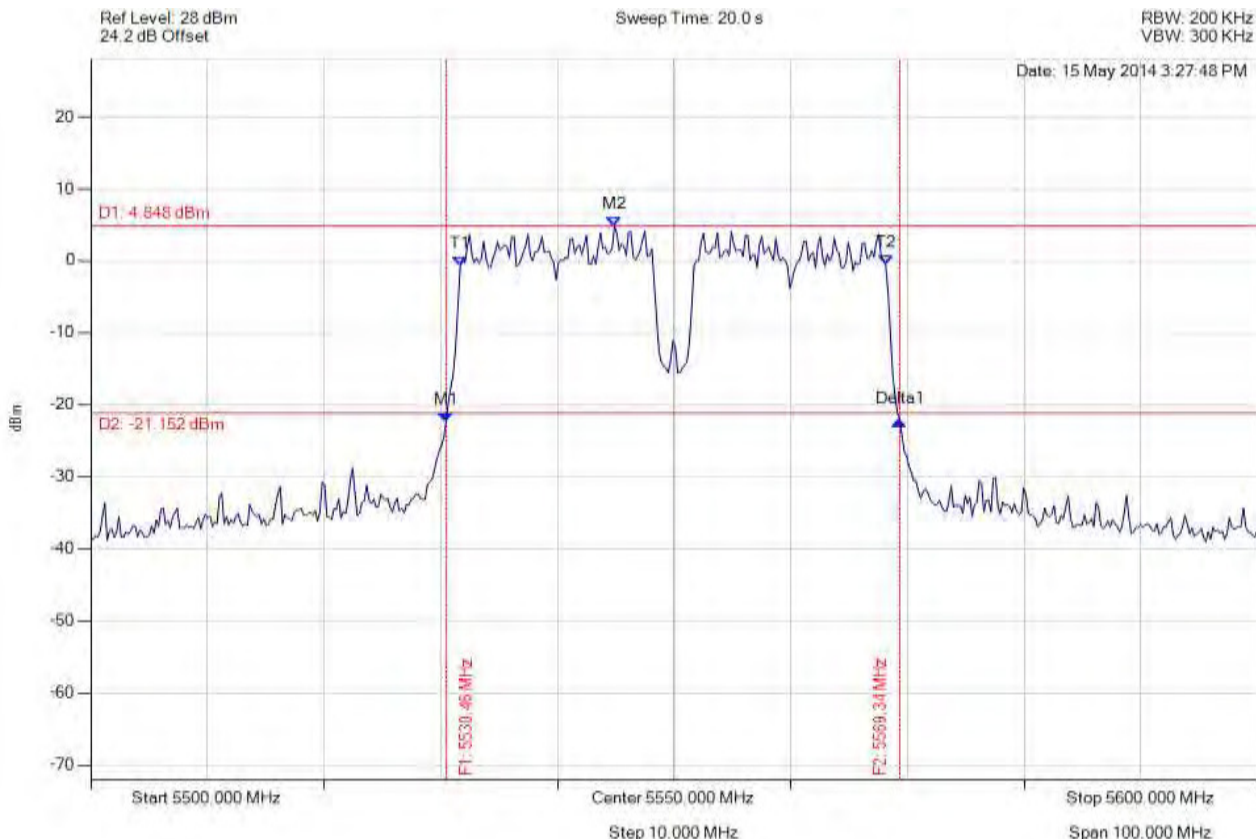

Analyser Setup	Marker : Frequency : Amplitude	Test Results
Detector = MAX PEAK Sweep Count = 0 RF Atten (dB) = 20 Trace Mode = VIEW	M1 : 5530.461 MHz : -22.329 dBm M2 : 5544.890 MHz : 4.848 dBm Delta1 : 38.878 MHz : 0.116 dB T1 : 5531.663 MHz : -0.765 dBm T2 : 5568.136 MHz : -0.564 dBm OBW : 36.473 MHz	Measured 26 dB Bandwidth: 38.878 MHz Measured 99% Bandwidth: 36.473 MHz

[Back to the Matrix](#)

This test report may be reproduced in full only. The document may only be updated by MiCOM Labs personnel. Any changes will be noted in the Document History section of the report.



Title: Aruba Networks APIN0214, APIN0215
To: FCC 47 CFR Part 15.407 & IC RSS-210
Serial #: ARUB179-U8 Rev B
Issue Date: 2nd September 2014
Page: 239 of 330



26 dB & 99% BANDWIDTH

Variant: 802.11n HT-40, Channel: 5710.00 MHz, Chain a, Temp: Ambient, Voltage: 12 Vdc

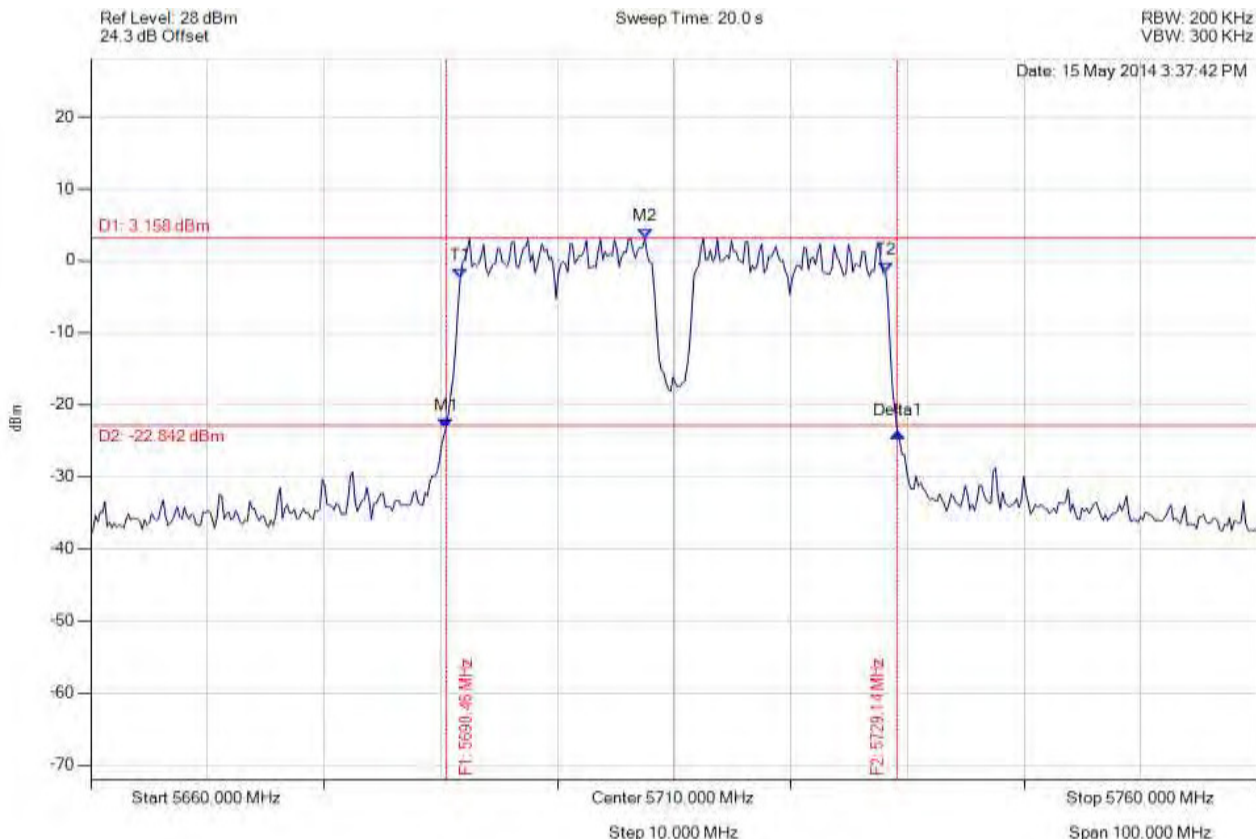

Analyser Setup	Marker : Frequency : Amplitude	Test Results
Detector = MAX PEAK Sweep Count = 0 RF Atten (dB) = 20 Trace Mode = VIEW	M1 : 5690.461 MHz : -23.198 dBm M2 : 5707.495 MHz : 3.158 dBm Delta1 : 38.677 MHz : -0.622 dB T1 : 5691.663 MHz : -2.402 dBm T2 : 5728.136 MHz : -1.504 dBm OBW : 36.473 MHz	Measured 26 dB Bandwidth: 38.677 MHz Measured 99% Bandwidth: 36.473 MHz

[Back to the Matrix](#)

This test report may be reproduced in full only. The document may only be updated by MiCOM Labs personnel. Any changes will be noted in the Document History section of the report.



Title: Aruba Networks APIN0214, APIN0215
To: FCC 47 CFR Part 15.407 & IC RSS-210
Serial #: ARUB179-U8 Rev B
Issue Date: 2nd September 2014
Page: 240 of 330



26 dB & 99% BANDWIDTH

Variant: 802.11n HT-40, Channel: 5710.00 MHz, Chain b, Temp: Ambient, Voltage: 12 Vdc

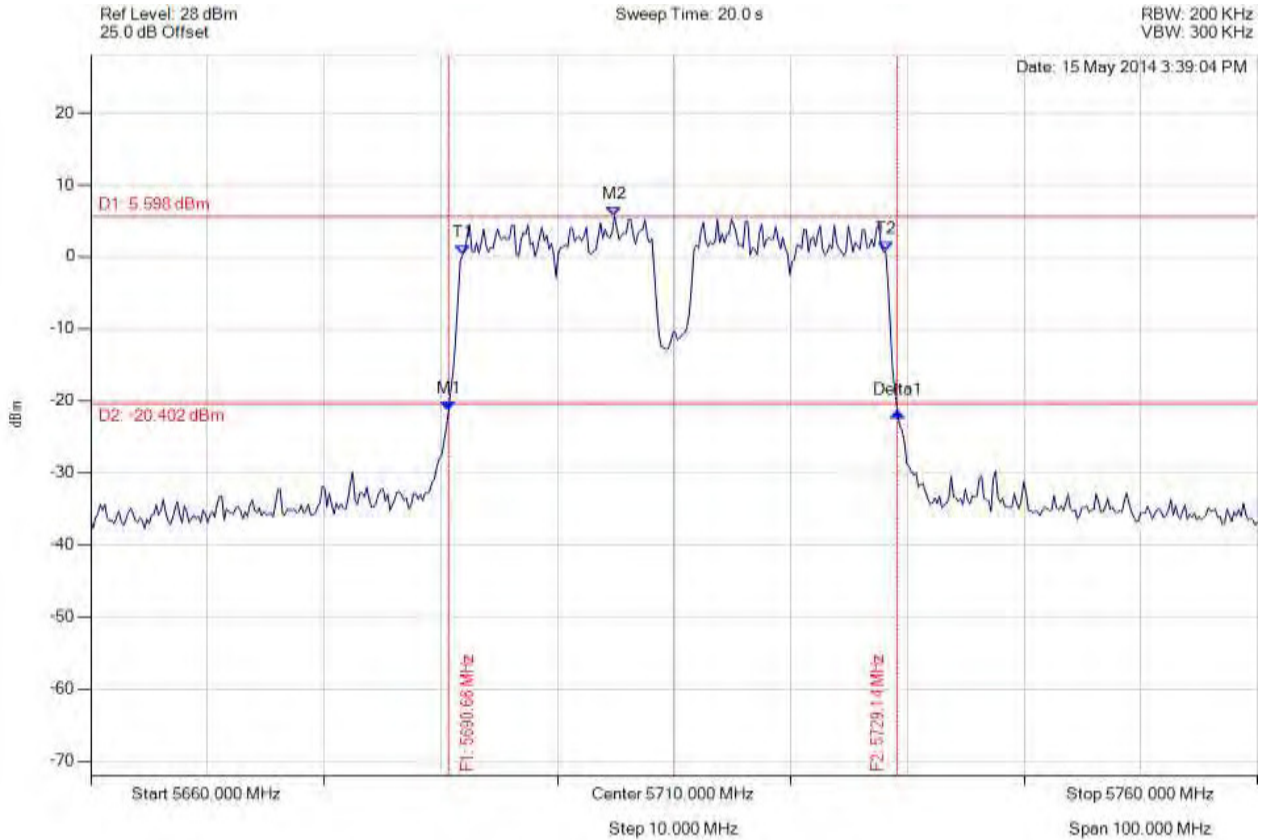

Analyser Setup	Marker : Frequency : Amplitude	Test Results
Detector = MAX PEAK Sweep Count = 0 RF Atten (dB) = 20 Trace Mode = VIEW	M1 : 5690.661 MHz : -21.459 dBm M2 : 5704.890 MHz : 5.598 dBm Delta1 : 38.477 MHz : -0.065 dB T1 : 5691.864 MHz : 0.304 dBm T2 : 5728.136 MHz : 0.797 dBm OBW : 36.273 MHz	Measured 26 dB Bandwidth: 38.477 MHz Measured 99% Bandwidth: 36.273 MHz

[Back to the Matrix](#)

This test report may be reproduced in full only. The document may only be updated by MiCOM Labs personnel. Any changes will be noted in the Document History section of the report.



Title: Aruba Networks APIN0214, APIN0215
To: FCC 47 CFR Part 15.407 & IC RSS-210
Serial #: ARUB179-U8 Rev B
Issue Date: 2nd September 2014
Page: 241 of 330



26 dB & 99% BANDWIDTH

Variant: 802.11n HT-40, Channel: 5710.00 MHz, Chain c, Temp: Ambient, Voltage: 12 Vdc

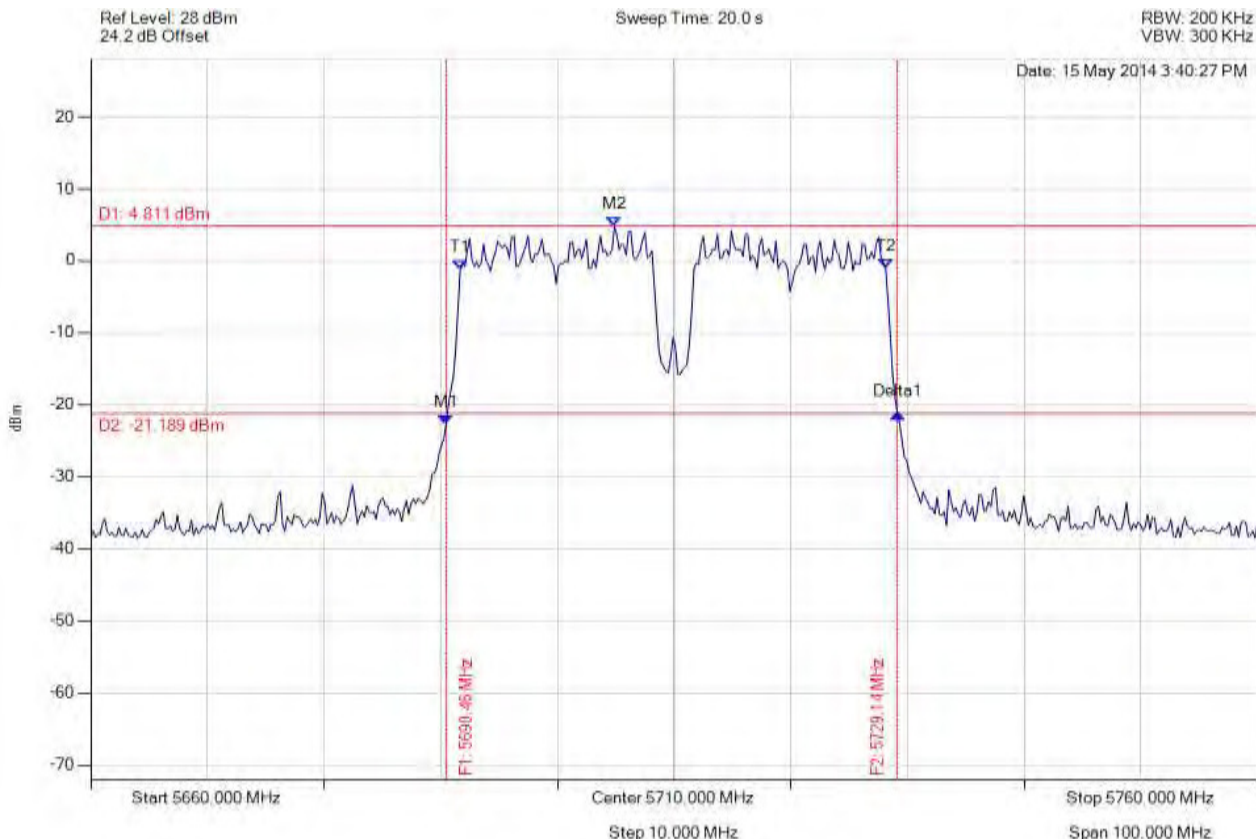

Analyser Setup	Marker : Frequency : Amplitude	Test Results
Detector = MAX PEAK Sweep Count = 0 RF Atten (dB) = 20 Trace Mode = VIEW	M1 : 5690.461 MHz : -22.705 dBm M2 : 5704.890 MHz : 4.811 dBm Delta1 : 38.677 MHz : 1.460 dB T1 : 5691.663 MHz : -1.205 dBm T2 : 5728.136 MHz : -1.009 dBm OBW : 36.473 MHz	Measured 26 dB Bandwidth: 38.677 MHz Measured 99% Bandwidth: 36.473 MHz

[Back to the Matrix](#)

This test report may be reproduced in full only. The document may only be updated by MiCOM Labs personnel. Any changes will be noted in the Document History section of the report.