

FCC Test Report

Report No.: RF130702E05C

FCC ID: Q87-E2500V3

Test Model: E2500

Received Date: Apr. 29, 2016

Test Date: Apr. 29 to May 09, 2016

Issued Date: July 28, 2016

Applicant: Linksys LLC

Address: 121 Theory Drive Irvine California 92617 United States

Issued By: Bureau Veritas Consumer Products Services (H.K.) Ltd., Taoyuan Branch
Hsin Chu Laboratory

Lab Address: E-2, No.1, Li Hsin 1st Road, Hsinchu Science Park, Hsinchu City 300,
Taiwan R.O.C.

Test Location: E-2, No.1, Li Hsin 1st Road, Hsinchu Science Park, Hsinchu City 300,
Taiwan R.O.C.



This report is for your exclusive use. Any copying or replication of this report to or for any other person or entity, or use of our name or trademark, is permitted only with our prior written permission. This report sets forth our findings solely with respect to the test samples identified herein. The results set forth in this report are not indicative or representative of the quality or characteristics of the lot from which a test sample was taken or any similar or identical product unless specifically and expressly noted. Our report includes all of the tests requested by you and the results thereof based upon the information that you provided to us. You have 60 days from date of issuance of this report to notify us of any material error or omission caused by our negligence, provided, however, that such notice shall be in writing and shall specifically address the issue you wish to raise. A failure to raise such issue within the prescribed time shall constitute your unqualified acceptance of the completeness of this report, the tests conducted and the correctness of the report contents. Unless specific mention, the uncertainty of measurement has been explicitly taken into account to declare the compliance or non-compliance to the specification. The report must not be used by the client to claim product certification, approval, or endorsement by TAF or any government agencies.

Table of Contents

Report Issue History Record	4
Release Control Record	4
1 Certificate of Conformity	5
2 Summary of Test Results	6
2.1 Measurement Uncertainty	6
2.2 Modification Record	6
3 General Information	7
3.1 General Description of EUT	7
3.2 Description of Test Modes	9
3.2.1 Test Mode Applicability and Tested Channel Detail	10
3.3 Duty Cycle of Test Signal	12
3.4 Description of Support Units	13
3.4.1 Configuration of System under Test	14
3.5 General Description of Applied Standard	15
4 Test Types and Results	16
4.1 Radiated Emission and Bandedge Measurement	16
4.1.1 Limits of Radiated Emission and Bandedge Measurement	16
4.1.2 Test Instruments	18
4.1.3 Test Procedure	19
4.1.4 Deviation from Test Standard	19
4.1.5 Test Setup	20
4.1.6 EUT Operating Condition	20
4.1.7 Test Results	21
4.2 Transmit Power Measurement	30
4.2.1 Limits of Transmit Power Measurement	30
4.2.2 Test Setup	30
4.2.3 Test Instruments	30
4.2.4 Test Procedure	30
4.2.5 Deviation from Test Standard	30
4.2.6 EUT Operating Condition	31
4.2.7 Test Result	32
4.3 Peak Power Spectral Density Measurement	33
4.3.1 Limits of Peak Power Spectral Density Measurement	33
4.3.2 Test Setup	33
4.3.3 Test Instruments	33
4.3.4 Test Procedure	33
4.3.5 Deviation from Test Standard	33
4.3.6 EUT Operating Condition	33
4.3.7 Test Results	34
4.4 Frequency Stability Measurement	36
4.4.1 Limits of Frequency Stability Measurement	36
4.4.2 Test Setup	36
4.4.3 Test Instruments	36
4.4.4 Test Procedure	36
4.4.5 Deviation from Test Standard	36
4.4.6 EUT Operating Condition	36
4.4.7 Test Results	37
4.5 6dB Bandwidth Measurement	38
4.5.1 Limits of 6dB Bandwidth Measurement	38
4.5.2 Test Setup	38
4.5.3 Test Instruments	38
4.5.4 Test Procedure	38



4.5.5 Deviation from Test Standard	38
4.5.6 EUT Operating Condition	38
4.5.7 Test Results	39
5 Pictures of Test Arrangements	41
Annex A- Radiated Out of Band Emisison (OOBE) Measurement (For U-NII-3 band)	42
Appendix – Information on the Testing Laboratories	45



Report Issue History Record

Issue No.	Reason for Change	Date Issued
RF130702E05 RF130702E05-1	Original	Aug. 09, 2013
RF130702E05B R1	Upgraded the standard to section 15.407 under new rule for U-NII-1 and U-NII-3 band.	Apr. 21, 2016
RF130702E05C	Upgraded the standard to section 15.407 under new rule (16-24) for U-NII-3 band.	July 28, 2016

Release Control Record

Issue No.	Description	Date Issued
RF130702E05C	Original release.	July 28, 2016



1 **Certificate of Conformity**

Product: Linksys E2500 Dual-Band Wireless-N Router
Brand: Linksys
Test Model: E2500
Sample Status: ENGINEERING SAMPLE
Applicant: Linksys LLC
Test Date: Apr. 29 to May 09, 2016
Standard: 47 CFR FCC Part 15, Subpart E (Section 15.407)
ANSI C63.10: 2013

The above equipment has been tested by **Bureau Veritas Consumer Products Services (H.K.) Ltd., Taoyuan Branch**, and found compliance with the requirement of the above standards. The test record, data evaluation & Equipment Under Test (EUT) configurations represented herein are true and accurate accounts of the measurements of the sample's EMC characteristics under the conditions specified in this report.

Prepared by : Wendy Wu , **Date:** July 28, 2016
Wendy Wu / Specialist

Approved by : May Chen , **Date:** July 28, 2016
May Chen / Manager

2 Summary of Test Results

47 CFR FCC Part 15, Subpart E (SECTION 15.407)			
FCC Clause	Test Item	Result	Remarks
15.407(b) (1/2/3/4(i/ii)/6)	Radiated Emissions & Band Edge Measurement*	Pass	Meet the requirement of limit. Minimum passing margin is -2.5dB at 17355.00MHz.
15.407(a)(1/2/3)	Max Average Transmit Power	Pass	Meet the requirement of limit.
15.407(a)(1/2/3)	Peak Power Spectral Density	Pass	Meet the requirement of limit.
15.407(e)	6dB bandwidth	Pass	Meet the requirement of limit. (U-NII-3 Band only)
15.407(g)	Frequency Stability	Pass	Meet the requirement of limit.
15.203	Antenna Requirement	Pass	No antenna connector is used.

*For U-NII-3 band compliance with rule part 15.407(b)(i), the OOB test plots were recorded in Annex A.

2.1 Measurement Uncertainty

Where relevant, the following measurement uncertainty levels have been estimated for tests performed on the EUT as specified in CISPR 16-4-2:

Measurement	Frequency	Expanded Uncertainty (k=2) (±)
Radiated Emissions up to 1 GHz	30MHz ~ 1GHz	5.19 dB
Radiated Emissions above 1 GHz	1GHz ~ 6GHz	3.40 dB
	6GHz ~ 18GHz	3.49 dB
	18GHz ~ 40GHz	4.11 dB

2.2 Modification Record

There were no modifications required for compliance.

3 General Information

3.1 General Description of EUT

Product	Linksys E2500 Dual-Band Wireless-N Router
Brand	Linksys
Test Model	E2500
Status of EUT	ENGINEERING SAMPLE
Driver version	3.0.01
Power Supply Rating	DC 12V from power adapter
Modulation Type	CCK, DQPSK, DBPSK for DSSS 64QAM, 16QAM, QPSK, BPSK for OFDM
Modulation Technology	DSSS, OFDM
Transfer Rate	802.11b: up to 11Mbps 802.11g/a: up to 54Mbps 802.11n: up to 270Mbps
Operating Frequency	2.4GHz: 2.412GHz ~ 2.462GHz 5GHz: 5.18GHz ~ 5.24GHz, 5.745GHz ~ 5.825GHz
Number of Channel	2.4GHz: 11 for 802.11b, 802.11g, 802.11n (HT20) 7 for 802.11n (HT40) 5GHz: 9 for 802.11a, 802.11n (HT20) 4 for 802.11n (HT40)
Output Power	2.4GHz: 570.997mW 5GHz (5.18 ~ 5.24GHz): 194.939mW 5GHz (5.745 ~ 5.825GHz): 155.934mW
Antenna Type	Refer to Note
Antenna Connector	NA
Accessory Device	Adapter x1
Data Cable Supplied	RJ-45 cable (unshielded, 1.8m)

Note:

- This report is prepared for FCC Class II change. The difference compared with the Report No.: RF130702E05B is as the following:
 - ◆ Upgrade the standard to section 15.407 under new rule (16-24) for U-NII-3 band.
- According to above conditions, all test items of U-NII-3 band need to be performed, except for AC power conducted emission test item. And all data was verified to meet the requirements.
- There are 2.4GHz and 5GHz WLAN technology used for the EUT.
- The EUT need to be supplied with power adapter as following table:

Brand	Model No.	Plug	Spec.
HK	HK-AO-120A100-US	US	Input: 100-240V, 0.5A, 50/60Hz Output: 12V, 1A DC power cable: 1.5m, unshielded

5. The antenna provided to the EUT, please refer to the following table:

2.4GHz			
Transmitter Circuit	Antenna Type	Antenna Gain (dBi)	Connector
Chain (0)	PIFA	2.5	NA
Chain (1)	PIFA	4	NA
5GHz			
Transmitter Circuit	Antenna Type	Antenna Gain (dBi)	Connector
Chain (0)	PIFA	4	NA
Chain (1)	PIFA	5	NA

6. The EUT incorporates a MIMO function.

MODULATION MODE	TX/RX FUNCTION
802.11a	1TX/2RX(diversity)
802.11b	1TX/2RX(diversity)
802.11g	1TX/2RX(diversity)
802.11n (HT20)	2TX/2RX
802.11n (HT40)	2TX/2RX

Note: For 802.11a mode will select Chain (1) for final test.

7. Spurious emission of the simultaneous operation (2.4GHz & 5GHz) has been evaluated and no non-compliance was found.
8. When the EUT operating in 802.11n, the software operation, which is defined by manufacturer, MCS (Modulation and Coding Schemes) from 0 to 15.
9. The above EUT information is declared by manufacturer and for more detailed features description, please refer to the manufacturer's specifications or user's manual.

3.2 Description of Test Modes

FOR 5745 ~ 5825MHz:

5 channels are provided for 802.11a, 802.11n (HT20):

Channel	Frequency	Channel	Frequency
149	5745MHz	161	5805MHz
153	5765MHz	165	5825MHz
157	5785MHz		

2 channels are provided for 802.11n (HT40):

Channel	Frequency	Channel	Frequency
151	5755MHz	159	5795MHz

3.2.1 Test Mode Applicability and Tested Channel Detail

EUT Configure Mode	Applicable To			Description
	RE \geq 1G	RE<1G	APCM	
-	√	√	√	-

Where **RE \geq 1G**: Radiated Emission above 1GHz **RE<1G**: Radiated Emission below 1GHz
APCM: Antenna Port Conducted Measurement

Radiated Emission Test (Above 1GHz):

- Pre-Scan has been conducted to determine the worst-case mode from all possible combinations between available modulations, data rates and antenna ports (if EUT with antenna diversity architecture).
- Following channel(s) was (were) selected for the final test as listed below.

MODE	FREQ. BAND (MHz)	AVAILABLE CHANNEL	TESTED CHANNEL	MODULATION TECHNOLOGY	MODULATION TYPE	DATA RATE (Mbps)
802.11a	5745-5825	149 to 165	149, 157, 165	OFDM	BPSK	6
802.11n (HT20)		149 to 165	149, 157, 165	OFDM	BPSK	6.5
802.11n (HT40)		151 to 159	151, 159	OFDM	BPSK	13.5

Radiated Emission Test (Below 1GHz):

- Pre-Scan has been conducted to determine the worst-case mode from all possible combinations between available modulations, data rates and antenna ports (if EUT with antenna diversity architecture).
- Following channel(s) was (were) selected for the final test as listed below.

MODE	FREQ. BAND (MHz)	AVAILABLE CHANNEL	TESTED CHANNEL	MODULATION TECHNOLOGY	MODULATION TYPE	DATA RATE (Mbps)
802.11n (HT20)	5745-5825	149 to 165	149	OFDM	BPSK	6.5

Antenna Port Conducted Measurement:

- This item includes all test value of each mode, but only includes spectrum plot of worst value of each mode.
- Pre-Scan has been conducted to determine the worst-case mode from all possible combinations between available modulations, data rates and antenna ports (if EUT with antenna diversity architecture).
- Following channel(s) was (were) selected for the final test as listed below.

MODE	FREQ. BAND (MHz)	AVAILABLE CHANNEL	TESTED CHANNEL	MODULATION TECHNOLOGY	MODULATION TYPE	DATA RATE (Mbps)
802.11a	5745-5825	149 to 165	149, 157, 165	OFDM	BPSK	6
802.11n (HT20)		149 to 165	149, 157, 165	OFDM	BPSK	6.5
802.11n (HT40)		151 to 159	151, 159	OFDM	BPSK	13.5

Test Condition:

Applicable To	Environmental Conditions	Input Power	Tested By
RE \geq 1G	25deg. C, 64%RH	120Vac, 60Hz	Andy Ho
RE<1G	20deg. C, 67%RH	120Vac, 60Hz	Tim Ho
APCM	25deg. C, 60%RH	120Vac, 60Hz	Robert Cheng

3.3 Duty Cycle of Test Signal

Duty cycle of test signal is $\geq 98\%$, duty factor is not required.

802.11a: Duty cycle = $2.063 \text{ ms} / 2.094 \text{ ms} = 0.985$

802.11n (HT20): Duty cycle = $1.905 \text{ ms} / 1.935 \text{ ms} = 0.984$

802.11n (HT40): Duty cycle = $1.231 \text{ ms} / 1.256 \text{ ms} = 0.98$

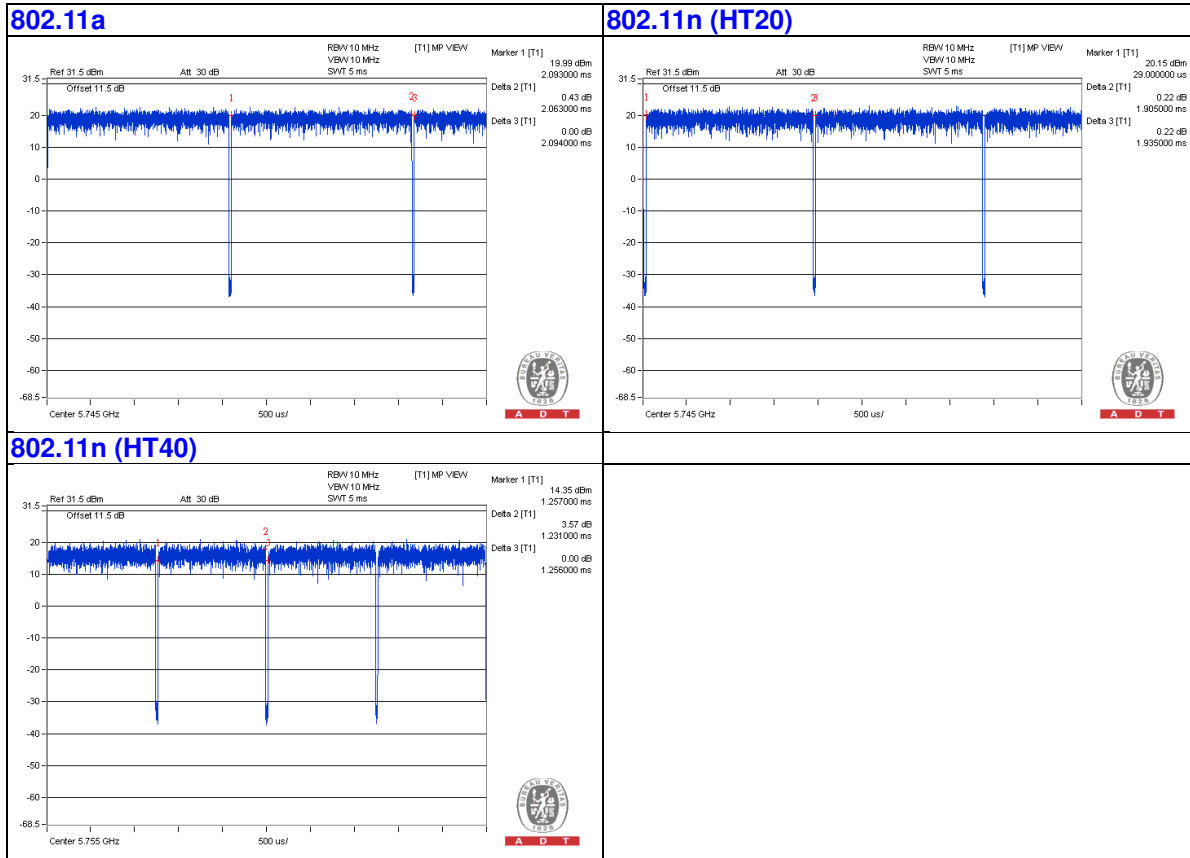

3.4 Description of Support Units

The EUT has been tested as an independent unit together with other necessary accessories or support units. The following support units or accessories were used to form a representative test configuration during the tests.

ID	Product	Brand	Model No.	Serial No.	FCC ID	Remarks
A.	iPod shuffle	Apple	MD778TA/A	CC4JG680F4T1	NA	Provided by Lab
B.	Notebook Computer	DELL	E5430	4YV4VY1	FCC DoC	Provided by Lab
C.	Notebook Computer	DELL	E5430	HYV4VY1	FCC DoC	Provided by Lab
D.	HUB	ZyXEL	ES-116P	S060H02000215	FCC DoC	Provided by Lab

Note:

1. All power cords of the above support units are non-shielded (1.8m).

ID	Descriptions	Qty.	Length (m)	Shielding (Yes/No)	Cores (Qty.)	Remarks
1.	DC	1	1.5	No	0	Supplied by Client
2.	USB	1	0.1	Yes	0	Provided by Lab
3.	RJ45	1	10	No	0	Provided by Lab
4.	RJ45	1	10	No	0	Provided by Lab
5.	RJ45	3	10	No	0	Provided by Lab

3.4.1 Configuration of System under Test

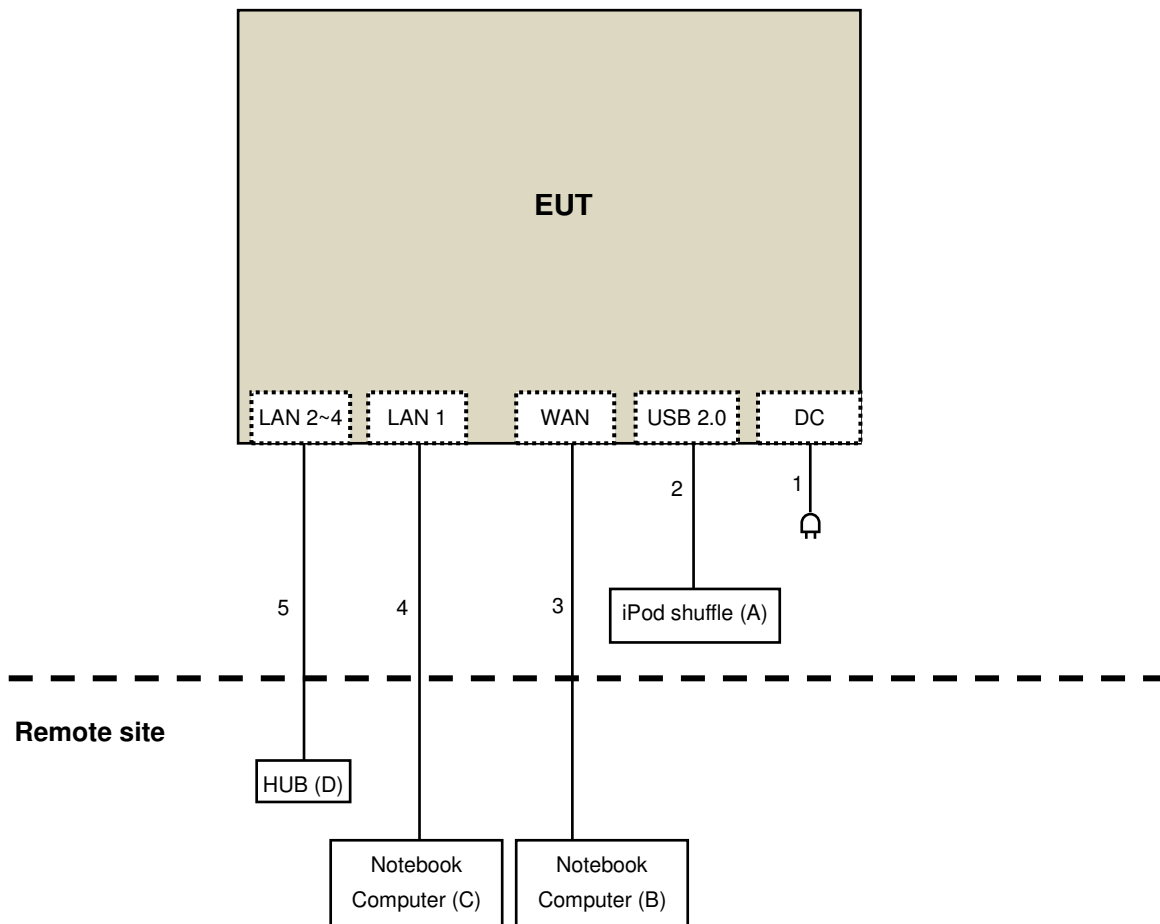

3.5 General Description of Applied Standard

The EUT is a RF Product. According to the specifications of the manufacturer, it must comply with the requirements of the following standards:

FCC Part 15, Subpart E (15.407)

KDB 789033 D02 General UNII Test Procedure New Rules v01r03

KDB 662911 D01 Multiple Transmitter Output v02r01

ANSI C63.10-2013

All test items have been performed and recorded as per the above standards.

NOTE: The EUT has been verified to comply with the requirements of FCC Part 15, Subpart B, Class B (DoC). The test report has been issued separately.

4 Test Types and Results

4.1 Radiated Emission and Bandedge Measurement

4.1.1 Limits of Radiated Emission and Bandedge Measurement

Radiated emissions which fall in the restricted bands must comply with the radiated emission limits specified as below table.

Frequencies (MHz)	Field Strength (microvolts/meter)	Measurement Distance (meters)
0.009 ~ 0.490	2400/F(kHz)	300
0.490 ~ 1.705	24000/F(kHz)	30
1.705 ~ 30.0	30	30
30 ~ 88	100	3
88 ~ 216	150	3
216 ~ 960	200	3
Above 960	500	3

NOTE:

1. The lower limit shall apply at the transition frequencies.
2. Emission level (dBuV/m) = 20 log Emission level (uV/m).
3. For frequencies above 1000MHz, the field strength limits are based on average detector, however, the peak field strength of any emission shall not exceed the maximum permitted average limits, specified above by more than 20dB under any condition of modulation.

Limits OF UNWANTED EMISSION OUT OF THE RESTRICTED Bands

Applicable To	Limit	
789033 D02 General UNII Test Procedure New Rules v01r03	FIELD STRENGTH at 3m	
	PK:74 (dBuV/m)	AV:54 (dBuV/m)
Applicable To	EIRP Limit	Equivalent Field Strength at 3m
15.407(b)(1)	PK:-27 (dBm/MHz)	PK:68.2(dBuV/m)
15.407(b)(2)		
15.407(b)(3)		
15.407(b)(4)(i)	PK:-27 (dBm/MHz) ^{*1} PK:10 (dBm/MHz) ^{*2} PK:15.6 (dBm/MHz) ^{*3} PK:27 (dBm/MHz) ^{*4}	PK: 68.2(dBuV/m) ^{*1} PK:105.2 (dBuV/m) ^{*2} PK: 110.8(dBuV/m) ^{*3} PK:122.2 (dBuV/m) ^{*4}
15.407(b)(4)(ii)	FIELD STRENGTH at 3m / § 15.247(d),	
	PK:74 (dBuV/m)	AV:54 (dBuV/m)
^{*1} beyond 75 MHz or more above of the band edge.		^{*2} below the band edge increasing linearly to 10 dBm/MHz at 25 MHz above.
^{*3} below the band edge increasing linearly to a level of 15.6 dBm/MHz at 5 MHz above.		^{*4} from 5 MHz above or below the band edge increasing linearly to a level of 27 dBm/MHz at the band edge.

NOTE:

The following formula is used to convert the equipment isotropic radiated power (eirp) to field strength:

$$E = \frac{1000000\sqrt{30P}}{3} \text{ } \mu\text{V/m, where P is the eirp (Watts).}$$



A D T

4.1.2 Test Instruments

DESCRIPTION & MANUFACTURER	MODEL NO.	SERIAL NO.	CALIBRATED DATE	CALIBRATED UNTIL
Test Receiver Agilent	N9038A	MY54450088	July 24, 2015	July 23, 2016
Pre-Amplifier ^(*) EMCI	EMC001340	980142	Jan. 20, 2016	Jan. 19, 2018
Loop Antenna ^(*) Electro-Metrics	EM-6879	264	Dec. 16, 2014	Dec. 15, 2016
RF Cable	NA	LOOPCAB-001 LOOPCAB-002	Jan. 18, 2016	Jan. 17, 2017
Pre-Amplifier Mini-Circuits	ZFL-1000VH2B	AMP-ZFL-01	Nov. 11, 2015	Nov. 10, 2016
Trilog Broadband Antenna SCHWARZBECK	VULB 9168	9168-406	Jan. 04, 2016	Jan. 03, 2017
RF Cable	8D	966-4-1 966-4-2 966-4-3	Apr. 02, 2016	Apr. 01, 2017
Horn_Antenna SCHWARZBECK	BBHA 9120D	9120D-783	Jan. 19, 2016	Jan. 18, 2017
Pre-Amplifier Agilent	8449B	3008A01922	Sep. 19, 2015	Sep. 18, 2016
RF Cable	EMC104-SM-SM-2000 EMC104-SM-SM-5000 EMC104-SM-SM-5000	150318 150323 150324	Mar. 30, 2016	Mar. 29, 2017
Pre-Amplifier EMCI	EMC184045	980143	Jan. 15, 2016	Jan. 14, 2017
Horn_Antenna SCHWARZBECK	BBHA 9170	BBHA9170608	Jan. 08, 2016	Jan. 07, 2017
RF Cable	SUCOFLEX 102	36432/2 36441/2	Jan. 16, 2016	Jan. 15, 2017
Software	ADT_Radiated_V8.7.07	NA	NA	NA
Antenna Tower & Turn Table Max-Full	MF-7802	MF780208410	NA	NA
Boresight Antenna Fixture	FBA-01	FBA-SIP02	NA	NA
Spectrum Analyzer R&S	FSP40	100036	Jan. 27, 2016	Jan. 26, 2017
Power meter Anritsu	ML2495A	0824006	May 25, 2015	May 24, 2016
Power sensor Anritsu	MA2411B	0738172	May 25, 2015	May 24, 2016
Temperature & Humidity Chamber GIANTFORCE	GTH-150-40-SP-AR	MAA0812-008	Jan. 15, 2016	Jan. 14, 2017

Note:

1. The calibration interval of the above test instruments is 12 months and the calibrations are traceable to NML/ROC and NIST/USA.
2. The horn antenna, preamplifier (model: 8449B) are used only for the measurement of emission frequency above 1GHz if tested.
3. The test was performed in 966 Chamber No. 4.
4. The FCC Site Registration No. is 292998
5. The CANADA Site Registration No. is 20331-2
6. Tested Date: Apr. 29 to May 09, 2016

4.1.3 Test Procedure

- a. The EUT was placed on the top of a rotating table 0.8 meters (for below 1GHz) / 1.5 meters (for above 1GHz) above the ground at 3 meter chamber room for test. The table was rotated 360 degrees to determine the position of the highest radiation.
- b. The EUT was set 3 meters away from the interference-receiving antenna, which was mounted on the top of a variable-height antenna tower.
- c. The height of antenna is varied from one meter to four meters above the ground to determine the maximum value of the field strength. Both horizontal and vertical polarizations of the antenna are set to make the measurement.
- d. For each suspected emission, the EUT was arranged to its worst case and then the antenna was tuned to heights from 1 meter to 4 meters and the rotatable table was turned from 0 degrees to 360 degrees to find the maximum reading.
- e. The test-receiver system was set to quasi-peak detect function and specified bandwidth with maximum hold mode when the test frequency is below 1 GHz.
- f. The test-receiver system was set to peak and average detect function and specified bandwidth with maximum hold mode when the test frequency is above 1 GHz. If the peak reading value also meets average limit, measurement with the average detector is unnecessary.

Note:

1. The resolution bandwidth and video bandwidth of test receiver/spectrum analyzer is 120kHz for Quasi-peak detection (QP) at frequency below 1GHz.
2. The resolution bandwidth of test receiver/spectrum analyzer is 1 MHz and the video bandwidth is 3 MHz for Peak detection (PK) at frequency above 1GHz.
3. The resolution bandwidth of test receiver/spectrum analyzer is 1MHz and the video bandwidth is 3MHz for RMS Average (Duty cycle < 98%) for Average detection (AV) at frequency above 1GHz, then the measurement results was added to a correction factor ($10 \log(1/\text{duty cycle})$).
4. The resolution bandwidth of test receiver/spectrum analyzer is 1MHz and the video bandwidth is 10Hz (Duty cycle $\geq 98\%$) for Average detection (AV) at frequency above 1GHz.
5. All modes of operation were investigated and the worst-case emissions are reported.

4.1.4 Deviation from Test Standard

No deviation.

4.1.5 Test Setup

<Frequency Range below 1GHz>

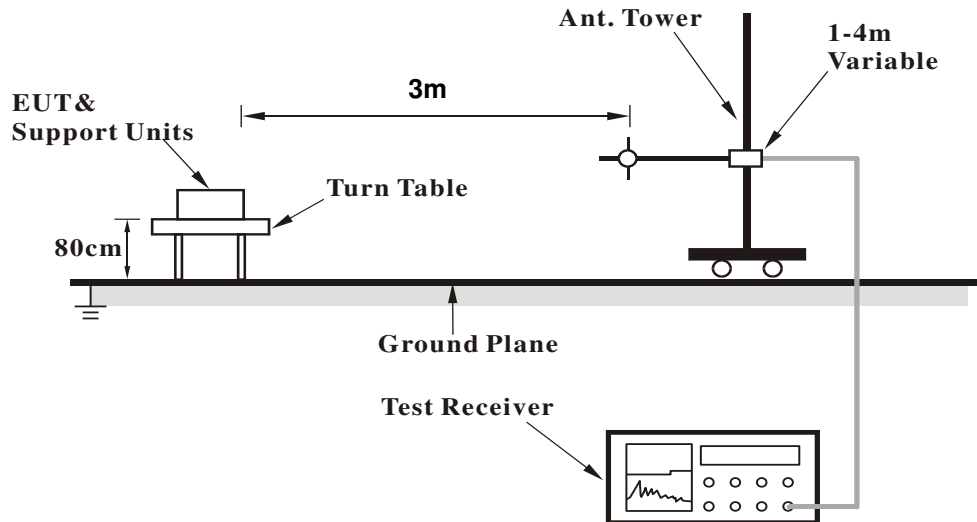

<Frequency Range above 1GHz>

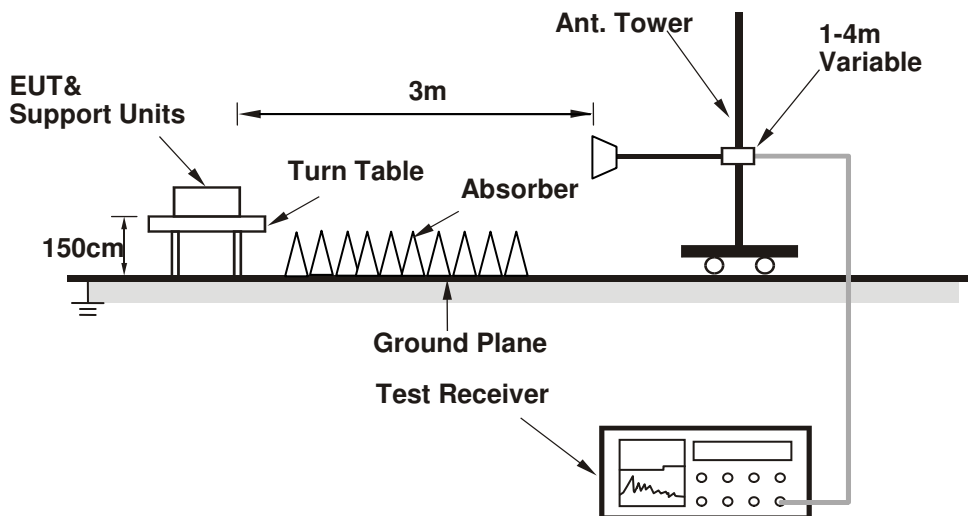

For the actual test configuration, please refer to the attached file (Test Setup Photo).

4.1.6 EUT Operating Condition

1. Connect the EUT with the support unit B & C (Notebook computer) which are placed in remote site.
2. The communication partner run test program "Mtool Ver.2.0.1.0" to enable EUT under transmission/receiving condition continuously at specific channel frequency.

4.1.7 Test Results

Above 1GHz Data:

802.11a

CHANNEL	TX Channel 149	DETECTOR FUNCTION	Peak (PK)
FREQUENCY RANGE	1GHz ~ 40GHz		Average (AV)

ANTENNA POLARITY & TEST DISTANCE: HORIZONTAL AT 3 M

NO.	FREQ. (MHz)	EMISSION LEVEL (dBuV/m)	LIMIT (dBuV/m)	MARGIN (dB)	ANTENNA HEIGHT (m)	TABLE ANGLE (Degree)	RAW VALUE (dBuV)	CORRECTION FACTOR (dB/m)
1	#5661.58	58.8 PK	76.8	-18.0	1.13 H	115	54.74	4.09
2	*5745.00	109.7 PK			1.13 H	115	106.88	2.82
3	*5745.00	100.0 AV			1.13 H	115	97.18	2.82
4	#5908.90	57.8 PK	80.1	-22.3	1.13 H	115	53.48	4.32
5	11490.00	54.4 PK	74.0	-19.6	1.17 H	321	40.94	13.46
6	11490.00	42.1 AV	54.0	-11.9	1.17 H	321	28.64	13.46
7	#17235.00	55.9 PK	74.0	-18.1	1.37 H	360	37.45	18.45
8	#17235.00	41.7 AV	54.0	-12.3	1.37 H	360	23.25	18.45

ANTENNA POLARITY & TEST DISTANCE: VERTICAL AT 3 M

NO.	FREQ. (MHz)	EMISSION LEVEL (dBuV/m)	LIMIT (dBuV/m)	MARGIN (dB)	ANTENNA HEIGHT (m)	TABLE ANGLE (Degree)	RAW VALUE (dBuV)	CORRECTION FACTOR (dB/m)
1	#5662.25	59.3 PK	77.3	-18.0	3.30 V	70	55.19	4.09
2	*5745.00	112.0 PK			3.30 V	70	109.18	2.82
3	*5745.00	102.4 AV			3.30 V	70	99.58	2.82
4	#5915.76	57.1 PK	75.0	-17.9	3.30 V	70	52.80	4.33
5	11490.00	60.2 PK	74.0	-13.8	1.00 V	360	46.74	13.46
6	11490.00	47.5 AV	54.0	-6.5	1.00 V	360	34.04	13.46
7	#17235.00	57.9 PK	74.0	-16.1	1.64 V	139	39.45	18.45
8	#17235.00	44.8 AV	54.0	-9.2	1.64 V	139	26.35	18.45

REMARKS:

1. Emission Level(dBuV/m) = Raw Value(dBuV) + Correction Factor(dB/m)
2. Correction Factor(dB/m) = Antenna Factor(dB/m) + Cable Factor(dB) – Pre-Amplifier Factor(dB)
3. The other emission levels were very low against the limit.
4. Margin value = Emission Level – Limit value
5. " * ": Fundamental frequency.
6. " # ": The radiated frequency is out of the restricted band.

CHANNEL	TX Channel 157	DETECTOR FUNCTION	Peak (PK)
FREQUENCY RANGE	1GHz ~ 40GHz		Average (AV)

ANTENNA POLARITY & TEST DISTANCE: HORIZONTAL AT 3 M

NO.	FREQ. (MHz)	EMISSION LEVEL (dBuV/m)	LIMIT (dBuV/m)	MARGIN (dB)	ANTENNA HEIGHT (m)	TABLE ANGLE (Degree)	RAW VALUE (dBuV)	CORRECTION FACTOR (dB/m)
1	#5661.59	58.5 PK	76.8	-18.4	1.22 H	119	54.36	4.09
2	*5785.00	109.1 PK			1.22 H	119	106.21	2.89
3	*5785.00	99.5 AV			1.22 H	119	96.61	2.89
4	#5912.90	57.3 PK	77.1	-19.8	1.22 H	119	52.96	4.33
5	11570.00	55.3 PK	74.0	-18.7	1.14 H	314	42.06	13.24
6	11570.00	42.5 AV	54.0	-11.5	1.14 H	314	29.26	13.24
7	#17355.00	57.0 PK	74.0	-17.0	1.37 H	360	37.90	19.10
8	#17355.00	42.7 AV	54.0	-11.3	1.37 H	360	23.60	19.10

ANTENNA POLARITY & TEST DISTANCE: VERTICAL AT 3 M

NO.	FREQ. (MHz)	EMISSION LEVEL (dBuV/m)	LIMIT (dBuV/m)	MARGIN (dB)	ANTENNA HEIGHT (m)	TABLE ANGLE (Degree)	RAW VALUE (dBuV)	CORRECTION FACTOR (dB/m)
1	#5674.44	58.4 PK	86.3	-27.9	3.44 V	72	54.31	4.12
2	*5785.00	111.4 PK			3.44 V	72	108.51	2.89
3	*5785.00	101.9 AV			3.44 V	72	99.01	2.89
4	#5905.26	57.9 PK	82.8	-24.9	3.44 V	72	53.58	4.31
5	11570.00	62.3 PK	74.0	-11.7	1.04 V	360	49.06	13.24
6	11570.00	49.6 AV	54.0	-4.4	1.04 V	360	36.36	13.24
7	#17355.00	57.5 PK	74.0	-16.5	1.62 V	142	38.40	19.10
8	#17355.00	44.4 AV	54.0	-9.6	1.62 V	142	25.30	19.10

REMARKS:

1. Emission Level(dBuV/m) = Raw Value(dBuV) + Correction Factor(dB/m)
2. Correction Factor(dB/m) = Antenna Factor(dB/m) + Cable Factor(dB) – Pre-Amplifier Factor(dB)
3. The other emission levels were very low against the limit.
4. Margin value = Emission Level – Limit value
5. " * ": Fundamental frequency.
6. " # ": The radiated frequency is out of the restricted band.



CHANNEL	TX Channel 165	DETECTOR FUNCTION	Peak (PK)
FREQUENCY RANGE	1GHz ~ 40GHz		Average (AV)

ANTENNA POLARITY & TEST DISTANCE: HORIZONTAL AT 3 M

NO.	FREQ. (MHz)	EMISSION LEVEL (dBuV/m)	LIMIT (dBuV/m)	MARGIN (dB)	ANTENNA HEIGHT (m)	TABLE ANGLE (Degree)	RAW VALUE (dBuV)	CORRECTION FACTOR (dB/m)
1	#5660.32	57.1 PK	75.9	-18.8	1.24 H	116	52.97	4.09
2	*5825.00	108.9 PK			1.24 H	116	105.96	2.94
3	*5825.00	99.0 AV			1.24 H	116	96.06	2.94
4	#5919.60	57.6 PK	72.2	-14.6	1.24 H	116	53.28	4.33
5	11650.00	55.0 PK	74.0	-19.0	1.14 H	323	41.79	13.21
6	11650.00	42.3 AV	54.0	-11.7	1.14 H	323	29.09	13.21
7	#17475.00	56.8 PK	74.0	-17.2	1.41 H	360	37.37	19.43
8	#17475.00	42.4 AV	54.0	-11.6	1.41 H	360	22.97	19.43

ANTENNA POLARITY & TEST DISTANCE: VERTICAL AT 3 M

NO.	FREQ. (MHz)	EMISSION LEVEL (dBuV/m)	LIMIT (dBuV/m)	MARGIN (dB)	ANTENNA HEIGHT (m)	TABLE ANGLE (Degree)	RAW VALUE (dBuV)	CORRECTION FACTOR (dB/m)
1	#5693.47	58.6 PK	100.4	-41.8	3.42 V	62	54.41	4.18
2	*5825.00	111.2 PK			3.42 V	62	108.26	2.94
3	*5825.00	101.4 AV			3.42 V	62	98.46	2.94
4	#5903.57	56.9 PK	84.0	-27.2	3.42 V	62	52.55	4.31
5	11650.00	61.7 PK	74.0	-12.3	1.06 V	360	48.49	13.21
6	11650.00	49.0 AV	54.0	-5.0	1.06 V	360	35.79	13.21
7	#17475.00	57.0 PK	74.0	-17.0	1.70 V	135	37.57	19.43
8	#17475.00	44.2 AV	54.0	-9.8	1.70 V	135	24.77	19.43

REMARKS:

1. Emission Level(dBuV/m) = Raw Value(dBuV) + Correction Factor(dB/m)
2. Correction Factor(dB/m) = Antenna Factor(dB/m) + Cable Factor(dB) – Pre-Amplifier Factor(dB)
3. The other emission levels were very low against the limit.
4. Margin value = Emission Level – Limit value
5. " * ": Fundamental frequency.
6. " # ": The radiated frequency is out of the restricted band.

802.11n (HT20)

CHANNEL	TX Channel 149	DETECTOR FUNCTION	Peak (PK)
FREQUENCY RANGE	1GHz ~ 40GHz		Average (AV)

ANTENNA POLARITY & TEST DISTANCE: HORIZONTAL AT 3 M								
NO.	FREQ. (MHz)	EMISSION LEVEL (dBuV/m)	LIMIT (dBuV/m)	MARGIN (dB)	ANTENNA HEIGHT (m)	TABLE ANGLE (Degree)	RAW VALUE (dBuV)	CORRECTION FACTOR (dB/m)
1	#5659.49	58.7 PK	75.3	-16.6	2.80 H	147	54.58	4.09
2	*5745.00	110.9 PK			2.80 H	147	108.08	2.82
3	*5745.00	100.8 AV			2.80 H	147	97.98	2.82
4	#5910.98	57.5 PK	78.5	-21.0	2.80 H	147	53.20	4.32
5	11490.00	54.4 PK	74.0	-19.6	1.19 H	332	40.94	13.46
6	11490.00	42.2 AV	54.0	-11.8	1.19 H	332	28.74	13.46
7	#17235.00	56.2 PK	74.0	-17.8	1.32 H	360	37.75	18.45
8	#17235.00	41.9 AV	54.0	-12.1	1.32 H	360	23.45	18.45

ANTENNA POLARITY & TEST DISTANCE: VERTICAL AT 3 M								
NO.	FREQ. (MHz)	EMISSION LEVEL (dBuV/m)	LIMIT (dBuV/m)	MARGIN (dB)	ANTENNA HEIGHT (m)	TABLE ANGLE (Degree)	RAW VALUE (dBuV)	CORRECTION FACTOR (dB/m)
1	#5685.24	65.7 PK	94.3	-28.6	2.78 V	77	61.53	4.16
2	*5745.00	113.1 PK			2.78 V	77	110.28	2.82
3	*5745.00	102.3 AV			2.78 V	77	99.48	2.82
4	#5904.39	56.6 PK	83.4	-26.9	2.78 V	77	52.24	4.31
5	11490.00	56.2 PK	74.0	-17.8	1.00 V	360	42.74	13.46
6	11490.00	45.7 AV	54.0	-8.3	1.00 V	360	32.24	13.46
7	#17235.00	59.8 PK	74.0	-14.2	1.63 V	166	41.35	18.45
8	#17235.00	47.2 AV	54.0	-6.8	1.63 V	166	28.75	18.45

REMARKS:

1. Emission Level(dBuV/m) = Raw Value(dBuV) + Correction Factor(dB/m)
2. Correction Factor(dB/m) = Antenna Factor(dB/m) + Cable Factor(dB) – Pre-Amplifier Factor(dB)
3. The other emission levels were very low against the limit.
4. Margin value = Emission Level – Limit value
5. " * ": Fundamental frequency.
6. " # ": The radiated frequency is out of the restricted band.



CHANNEL	TX Channel 157	DETECTOR FUNCTION	Peak (PK)
FREQUENCY RANGE	1GHz ~ 40GHz		Average (AV)

ANTENNA POLARITY & TEST DISTANCE: HORIZONTAL AT 3 M

NO.	FREQ. (MHz)	EMISSION LEVEL (dBuV/m)	LIMIT (dBuV/m)	MARGIN (dB)	ANTENNA HEIGHT (m)	TABLE ANGLE (Degree)	RAW VALUE (dBuV)	CORRECTION FACTOR (dB/m)
1	#5664.53	58.0 PK	79.0	-21.0	1.82 H	345	53.85	4.10
2	*5785.00	110.0 PK			1.83 H	345	107.11	2.89
3	*5785.00	99.8 AV			1.83 H	345	96.91	2.89
4	#5923.33	57.4 PK	69.4	-12.1	1.82 H	345	53.01	4.34
5	11570.00	57.9 PK	74.0	-16.1	1.24 H	136	44.66	13.24
6	11570.00	45.6 AV	54.0	-8.4	1.24 H	136	32.36	13.24
7	#17355.00	57.3 PK	74.0	-16.7	1.52 H	184	38.20	19.10
8	#17355.00	45.0 AV	54.0	-9.0	1.52 H	184	25.90	19.10

ANTENNA POLARITY & TEST DISTANCE: VERTICAL AT 3 M

NO.	FREQ. (MHz)	EMISSION LEVEL (dBuV/m)	LIMIT (dBuV/m)	MARGIN (dB)	ANTENNA HEIGHT (m)	TABLE ANGLE (Degree)	RAW VALUE (dBuV)	CORRECTION FACTOR (dB/m)
1	#5668.79	57.8 PK	82.1	-24.4	1.37 V	295	53.68	4.11
2	*5785.00	111.9 PK			1.37 V	295	109.01	2.89
3	*5785.00	101.6 AV			1.37 V	295	98.71	2.89
4	#5920.58	57.2 PK	71.5	-14.2	1.37 V	295	52.90	4.33
5	11570.00	60.1 PK	74.0	-13.9	2.49 V	322	46.86	13.24
6	11570.00	48.1 AV	54.0	-5.9	2.49 V	322	34.86	13.24
7	#17355.00	65.2 PK	74.0	-8.8	3.99 V	216	46.10	19.10
8	#17355.00	51.5 AV	54.0	-2.5	3.99 V	216	32.40	19.10

REMARKS:

1. Emission Level(dBuV/m) = Raw Value(dBuV) + Correction Factor(dB/m)
2. Correction Factor(dB/m) = Antenna Factor(dB/m) + Cable Factor(dB) – Pre-Amplifier Factor(dB)
3. The other emission levels were very low against the limit.
4. Margin value = Emission Level – Limit value
5. " * ": Fundamental frequency.
6. " # ": The radiated frequency is out of the restricted band.

CHANNEL	TX Channel 165	DETECTOR FUNCTION	Peak (PK)
FREQUENCY RANGE	1GHz ~ 40GHz		Average (AV)

ANTENNA POLARITY & TEST DISTANCE: HORIZONTAL AT 3 M

NO.	FREQ. (MHz)	EMISSION LEVEL (dBuV/m)	LIMIT (dBuV/m)	MARGIN (dB)	ANTENNA HEIGHT (m)	TABLE ANGLE (Degree)	RAW VALUE (dBuV)	CORRECTION FACTOR (dB/m)
1	#5655.81	57.8 PK	72.5	-14.8	2.71 H	145	53.69	4.08
2	*5825.00	111.0 PK			2.72 H	147	108.06	2.94
3	*5825.00	100.8 AV			2.72 H	147	97.86	2.94
4	#5916.15	57.1 PK	74.7	-17.7	2.71 H	145	52.72	4.33
5	11650.00	57.1 PK	74.0	-16.9	1.15 H	316	43.89	13.21
6	11650.00	44.8 AV	54.0	-9.2	1.15 H	316	31.59	13.21
7	#17475.00	56.4 PK	74.0	-17.6	1.42 H	360	36.97	19.43
8	#17475.00	44.1 AV	54.0	-9.9	1.42 H	360	24.67	19.43

ANTENNA POLARITY & TEST DISTANCE: VERTICAL AT 3 M

NO.	FREQ. (MHz)	EMISSION LEVEL (dBuV/m)	LIMIT (dBuV/m)	MARGIN (dB)	ANTENNA HEIGHT (m)	TABLE ANGLE (Degree)	RAW VALUE (dBuV)	CORRECTION FACTOR (dB/m)
1	#5663.73	56.8 PK	78.4	-21.6	1.30 V	294	52.66	4.09
2	*5825.00	113.3 PK			1.30 V	294	110.36	2.94
3	*5825.00	103.2 AV			1.30 V	294	100.26	2.94
4	#5911.25	57.5 PK	78.3	-20.8	1.30 V	294	53.19	4.32
5	11650.00	59.1 PK	74.0	-14.9	1.07 V	360	45.89	13.21
6	11650.00	47.1 AV	54.0	-6.9	1.07 V	360	33.89	13.21
7	#17475.00	63.8 PK	74.0	-10.2	1.64 V	161	44.37	19.43
8	#17475.00	50.2 AV	54.0	-3.8	1.64 V	161	30.77	19.43

REMARKS:

1. Emission Level(dBuV/m) = Raw Value(dBuV) + Correction Factor(dB/m)
2. Correction Factor(dB/m) = Antenna Factor(dB/m) + Cable Factor(dB) – Pre-Amplifier Factor(dB)
3. The other emission levels were very low against the limit.
4. Margin value = Emission Level – Limit value
5. " * ": Fundamental frequency.
6. " # ": The radiated frequency is out of the restricted band.

802.11n (HT40)

CHANNEL	TX Channel 151	DETECTOR FUNCTION	Peak (PK)
FREQUENCY RANGE	1GHz ~ 40GHz		Average (AV)

ANTENNA POLARITY & TEST DISTANCE: HORIZONTAL AT 3 M

NO.	FREQ. (MHz)	EMISSION LEVEL (dBuV/m)	LIMIT (dBuV/m)	MARGIN (dB)	ANTENNA HEIGHT (m)	TABLE ANGLE (Degree)	RAW VALUE (dBuV)	CORRECTION FACTOR (dB/m)
1	#5656.65	64.0 PK	73.1	-9.1	1.78 H	344	59.93	4.08
2	*5755.00	107.1 PK			1.78 H	344	104.26	2.84
3	*5755.00	97.1 AV			1.78 H	344	94.26	2.84
4	#5906.15	58.6 PK	82.1	-23.6	1.78 H	344	54.25	4.31
5	11510.00	54.2 PK	74.0	-19.8	1.19 H	325	40.77	13.43
6	11510.00	41.7 AV	54.0	-12.3	1.19 H	325	28.27	13.43
7	#17265.00	55.2 PK	74.0	-18.8	1.33 H	360	36.64	18.56
8	#17265.00	41.3 AV	54.0	-12.7	1.33 H	360	22.74	18.56

ANTENNA POLARITY & TEST DISTANCE: VERTICAL AT 3 M

NO.	FREQ. (MHz)	EMISSION LEVEL (dBuV/m)	LIMIT (dBuV/m)	MARGIN (dB)	ANTENNA HEIGHT (m)	TABLE ANGLE (Degree)	RAW VALUE (dBuV)	CORRECTION FACTOR (dB/m)
1	#5659.95	66.0 PK	75.6	-9.6	1.14 V	286	61.94	4.09
2	*5755.00	109.4 PK			1.14 V	286	106.56	2.84
3	*5755.00	99.5 AV			1.14 V	286	96.66	2.84
4	#5910.01	61.9 PK	79.3	-17.4	1.14 V	286	57.59	4.32
5	11510.00	54.7 PK	74.0	-19.3	2.48 V	320	41.27	13.43
6	11510.00	42.6 AV	54.0	-11.4	2.48 V	320	29.17	13.43
7	#17265.00	55.4 PK	74.0	-18.6	4.00 V	226	36.84	18.56
8	#17265.00	41.4 AV	54.0	-12.6	4.00 V	226	22.84	18.56

REMARKS:

- Emission Level(dBuV/m) = Raw Value(dBuV) + Correction Factor(dB/m)
- Correction Factor(dB/m) = Antenna Factor(dB/m) + Cable Factor(dB) – Pre-Amplifier Factor(dB)
- The other emission levels were very low against the limit.
- Margin value = Emission Level – Limit value
- " * ": Fundamental frequency.
- " # ": The radiated frequency is out of the restricted band.

CHANNEL	TX Channel 159	DETECTOR FUNCTION	Peak (PK)
FREQUENCY RANGE	1GHz ~ 40GHz		Average (AV)

ANTENNA POLARITY & TEST DISTANCE: HORIZONTAL AT 3 M

NO.	FREQ. (MHz)	EMISSION LEVEL (dBuV/m)	LIMIT (dBuV/m)	MARGIN (dB)	ANTENNA HEIGHT (m)	TABLE ANGLE (Degree)	RAW VALUE (dBuV)	CORRECTION FACTOR (dB/m)
1	#5677.57	67.4 PK	88.6	-21.3	2.50 H	119	63.25	4.12
2	*5795.00	109.7 PK			2.50 H	119	106.78	2.92
3	*5795.00	98.3 AV			2.50 H	119	95.38	2.92
4	#5924.10	63.8 PK	68.9	-5.0	2.50 H	119	59.49	4.34
5	11590.00	54.2 PK	74.0	-19.8	1.12 H	324	41.02	13.18
6	11590.00	42.1 AV	54.0	-11.9	1.12 H	324	28.92	13.18
7	#17385.00	56.2 PK	74.0	-17.8	1.36 H	360	36.88	19.32
8	#17385.00	42.0 AV	54.0	-12.0	1.36 H	360	22.68	19.32

ANTENNA POLARITY & TEST DISTANCE: VERTICAL AT 3 M

NO.	FREQ. (MHz)	EMISSION LEVEL (dBuV/m)	LIMIT (dBuV/m)	MARGIN (dB)	ANTENNA HEIGHT (m)	TABLE ANGLE (Degree)	RAW VALUE (dBuV)	CORRECTION FACTOR (dB/m)
1	#5699.24	72.9 PK	104.6	-31.7	1.14 V	297	68.72	4.19
2	*5795.00	108.8 PK			1.14 V	297	105.88	2.92
3	*5795.00	99.2 AV			1.14 V	297	96.28	2.92
4	#5917.01	66.6 PK	74.1	-7.5	1.14 V	297	62.30	4.33
5	11590.00	54.5 PK	74.0	-19.5	2.45 V	329	41.32	13.18
6	11590.00	42.3 AV	54.0	-11.7	2.45 V	329	29.12	13.18
7	#17385.00	55.5 PK	74.0	-18.5	4.00 V	218	36.18	19.32
8	#17385.00	41.3 AV	54.0	-12.7	4.00 V	218	21.98	19.32

REMARKS:

1. Emission Level(dBuV/m) = Raw Value(dBuV) + Correction Factor(dB/m)
2. Correction Factor(dB/m) = Antenna Factor(dB/m) + Cable Factor(dB) – Pre-Amplifier Factor(dB)
3. The other emission levels were very low against the limit.
4. Margin value = Emission Level – Limit value
5. " * ": Fundamental frequency.
6. " # ": The radiated frequency is out of the restricted band.

Below 1GHz Data:
802.11n (HT20)

CHANNEL	TX Channel 149	DETECTOR FUNCTION	Quasi-Peak (QP)
FREQUENCY RANGE	below 1GHz		

ANTENNA POLARITY & TEST DISTANCE: HORIZONTAL AT 3 M

NO.	FREQ. (MHz)	EMISSION LEVEL (dBuV/m)	LIMIT (dBuV/m)	MARGIN (dB)	ANTENNA HEIGHT (m)	TABLE ANGLE (Degree)	RAW VALUE (dBuV)	CORRECTION FACTOR (dB/m)
1	36.15	28.1 QP	40.0	-11.9	2.00 H	313	37.82	-9.71
2	73.16	30.7 QP	40.0	-9.3	2.00 H	106	42.46	-11.73
3	81.21	33.2 QP	40.0	-6.8	2.00 H	77	47.05	-13.87
4	148.16	29.2 QP	43.5	-14.3	2.00 H	254	37.72	-8.51
5	250.11	29.8 QP	46.0	-16.2	1.45 H	22	39.62	-9.84
6	599.86	38.9 QP	46.0	-7.1	1.37 H	318	39.45	-0.59

ANTENNA POLARITY & TEST DISTANCE: VERTICAL AT 3 M

NO.	FREQ. (MHz)	EMISSION LEVEL (dBuV/m)	LIMIT (dBuV/m)	MARGIN (dB)	ANTENNA HEIGHT (m)	TABLE ANGLE (Degree)	RAW VALUE (dBuV)	CORRECTION FACTOR (dB/m)
1	73.83	31.8 QP	40.0	-8.2	2.00 V	118	43.61	-11.80
2	110.77	32.7 QP	43.5	-10.8	1.50 V	112	44.12	-11.41
3	141.30	31.2 QP	43.5	-12.3	2.00 V	283	40.14	-8.90
4	250.12	29.5 QP	46.0	-16.5	1.00 V	28	39.37	-9.84
5	625.06	34.8 QP	46.0	-11.2	1.50 V	41	34.90	-0.08
6	750.14	37.4 QP	46.0	-8.6	1.00 V	36	35.51	1.88

REMARKS:

1. Emission Level(dBuV/m) = Raw Value(dBuV) + Correction Factor(dB/m)
2. Correction Factor(dB/m) = Antenna Factor(dB/m) + Cable Factor(dB) – Pre-Amplifier Factor(dB)
3. The other emission levels were very low against the limit.
4. Margin value = Emission Level – Limit value

4.2 Transmit Power Measurement

4.2.1 Limits of Transmit Power Measurement

Operation Band	EUT Category		Limit
U-NII-1		Outdoor Access Point	1 Watt (30 dBm) (Max. e.i.r.p \leq 125mW(21 dBm) at any elevation angle above 30 degrees as measured from the horizon)
		Fixed point-to-point Access Point	1 Watt (30 dBm)
		Indoor Access Point	1 Watt (30 dBm)
		Mobile and Portable client device	250mW (24 dBm)
U-NII-2A			250mW (24 dBm) or 11 dBm+10 log B*
U-NII-2C			250mW (24 dBm) or 11 dBm+10 log B*
U-NII-3	√		1 Watt (30 dBm)

*B is the 26 dB emission bandwidth in megahertz

Per KDB 662911 Method of conducted output power measurement on IEEE 802.11 devices,

Array Gain = 0 dB (i.e., no array gain) for $N_{ANT} \leq 4$;

Array Gain = 0 dB (i.e., no array gain) for channel widths ≥ 40 MHz for any N_{ANT} ;

Array Gain = $5 \log(N_{ANT}/N_{SS})$ dB or 3 dB, whichever is less for 20-MHz channel widths with $N_{ANT} \geq 5$.

For power measurements on all other devices: Array Gain = $10 \log(N_{ANT}/N_{SS})$ dB.

4.2.2 Test Setup

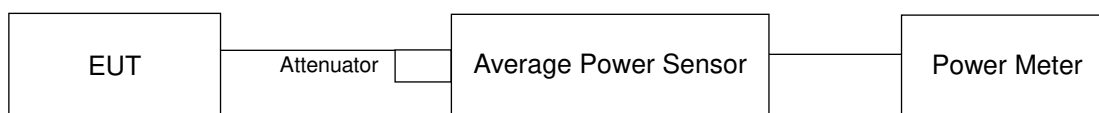

4.2.3 Test Instruments

Refer to section 4.1.2 to get information of above instrument.

4.2.4 Test Procedure

Method PM is used to perform output power measurement, trigger and gating function of wide band power meter is enabled to measure max output power of TX on burst. Duty factor is not added to measured value.

4.2.5 Deviation from Test Standard

No deviation.

4.2.6 EUT Operating Condition

The software provided by client to enable the EUT under transmission condition continuously at lowest, middle and highest channel frequencies individually.

4.2.7 Test Result
802.11a

Chan.	Chan. Freq. (MHz)	Average Power (mW)	Average Power (dBm)	Limit (dBm)	Pass / Fail
149	5745	87.498	19.42	30	Pass
157	5785	86.896	19.39	30	Pass
165	5825	85.114	19.30	30	Pass

802.11n (HT20)

Chan.	Chan. Freq. (MHz)	Average Power (dBm)		Total Power (mW)	Total Power (dBm)	Limit (dBm)	Pass / Fail
		Chain 0	Chain 1				
149	5745	18.34	19.43	155.934	21.93	30	Pass
157	5785	18.23	19.41	153.824	21.87	30	Pass
165	5825	18.30	19.38	154.304	21.88	30	Pass

802.11n (HT40)

Chan.	Chan. Freq. (MHz)	Average Power (dBm)		Total Power (mW)	Total Power (dBm)	Limit (dBm)	Pass / Fail
		Chain 0	Chain 1				
151	5755	18.36	19.06	149.087	21.73	30	Pass
159	5795	18.33	19.12	149.735	21.75	30	Pass

4.3 Peak Power Spectral Density Measurement

4.3.1 Limits of Peak Power Spectral Density Measurement

Operation Band	EUT Category		Limit
U-NII-1		Outdoor Access Point	17dBm/ MHz
		Fixed point-to-point Access Point	
		Indoor Access Point	
		Mobile and Portable client device	11dBm/ MHz
U-NII-2A			11dBm/ MHz
U-NII-2C			11dBm/ MHz
U-NII-3	√		30dBm/ 500kHz

4.3.2 Test Setup

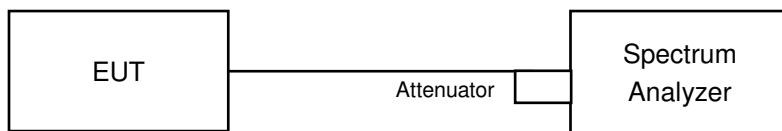

4.3.3 Test Instruments

Refer to section 4.1.2 to get information of above instrument.

4.3.4 Test Procedure

1. Set span to encompass the entire emission bandwidth (EBW) of the signal.
2. Set RBW = 300 kHz, Set VBW ≥ 1 MHz, Detector = RMS
3. Use the peak marker function to determine the maximum power level in any 300 kHz band segment within the fundamental EBW.
4. Scale the observed power level to an equivalent value in 500 kHz by adjusting (reducing) the measured power by a bandwidth correction factor (BWCF) where $BWCF = 10\log(500\text{ kHz}/300\text{kHz})$
5. Sweep time = auto, trigger set to “free run”.
6. Trace average at least 100 traces in power averaging mode.
7. Record the max value

4.3.5 Deviation from Test Standard

No deviation.

4.3.6 EUT Operating Condition

Same as Item 4.3.6.

4.3.7 Test Results

802.11a

Chan.	Chan. Freq. (MHz)	PSD (dBm/300kHz)	PSD (dBm/500kHz)	Limit (dBm/500kHz)	Pass /Fail
149	5745	-0.86	1.36	30	Pass
157	5785	-1.13	1.09	30	Pass
165	5825	-1.19	1.03	30	Pass

802.11n (HT20)

TX chain	Chan.	Chan. Freq. (MHz)	PSD		10 log (N=2) dB	Total PSD (dBm/500kHz)	Limit (dBm/500kHz)	Pass /Fail
			(dBm/300kHz)	(dBm/500kHz)				
0	149	5745	-1.26	0.96	3.01	3.97	28.48	Pass
	157	5785	-1.37	0.85	3.01	3.86	28.48	Pass
	165	5825	-1.45	0.77	3.01	3.78	28.48	Pass
1	149	5745	-1.32	0.90	3.01	3.91	28.48	Pass
	157	5785	-1.37	0.85	3.01	3.86	28.48	Pass
	165	5825	-1.46	0.76	3.01	3.77	28.48	Pass

Note: 1. Directional gain = $10 \log[(10^{G1/20} + 10^{G2/20})^2 / 2] = 7.52\text{dBi} > 6\text{dBi}$, therefore the limit needs to reduce, so the power density limit shall be reduced to $30 - (7.52 - 6) = 28.48\text{dBm}$.

802.11n (HT40)

TX chain	Chan.	Chan. Freq. (MHz)	PSD		10 log (N=2) dB	Total PSD (dBm/500kHz)	Limit (dBm/500kHz)	Pass /Fail
			(dBm/300kHz)	(dBm/500kHz)				
0	151	5755	-5.26	-3.04	3.01	-0.03	28.48	Pass
	159	5795	-5.15	-2.93	3.01	0.08	28.48	Pass
1	151	5755	-5.64	-3.42	3.01	-0.41	28.48	Pass
	159	5795	-5.53	-3.31	3.01	-0.30	28.48	Pass

Note: 1. Directional gain = $10 \log[(10^{G1/20} + 10^{G2/20})^2 / 2] = 7.52\text{dBi} > 6\text{dBi}$, therefore the limit needs to reduce, so the power density limit shall be reduced to $30 - (7.52 - 6) = 28.48\text{dBm}$.

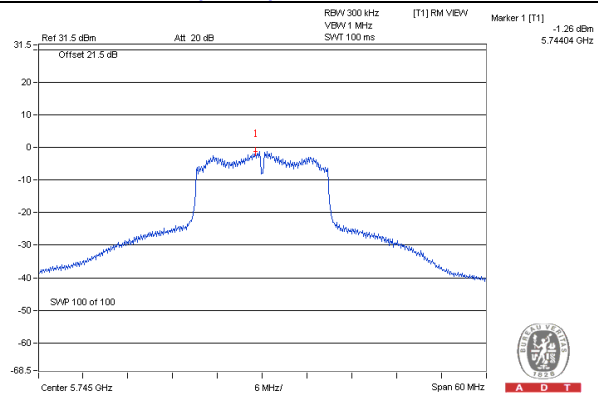
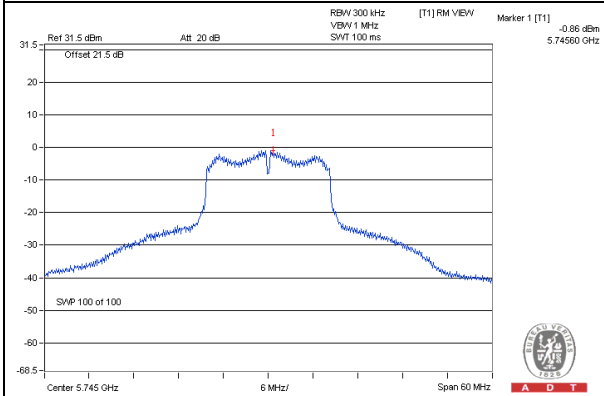
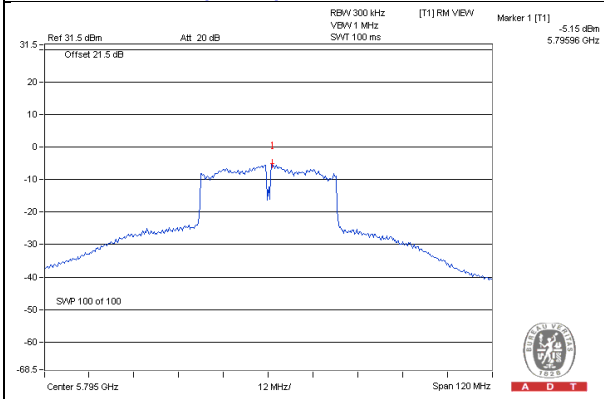
Spectrum Plot of Worst Value**802.11a – Chain 1: CH 149****802.11n (HT20) – Chain 0: CH 149****802.11n (HT40) – Chain 0: CH 159**

4.4 Frequency Stability Measurement

4.4.1 Limits of Frequency Stability Measurement

The frequency of the carrier signal shall be maintained within band of operation

4.4.2 Test Setup

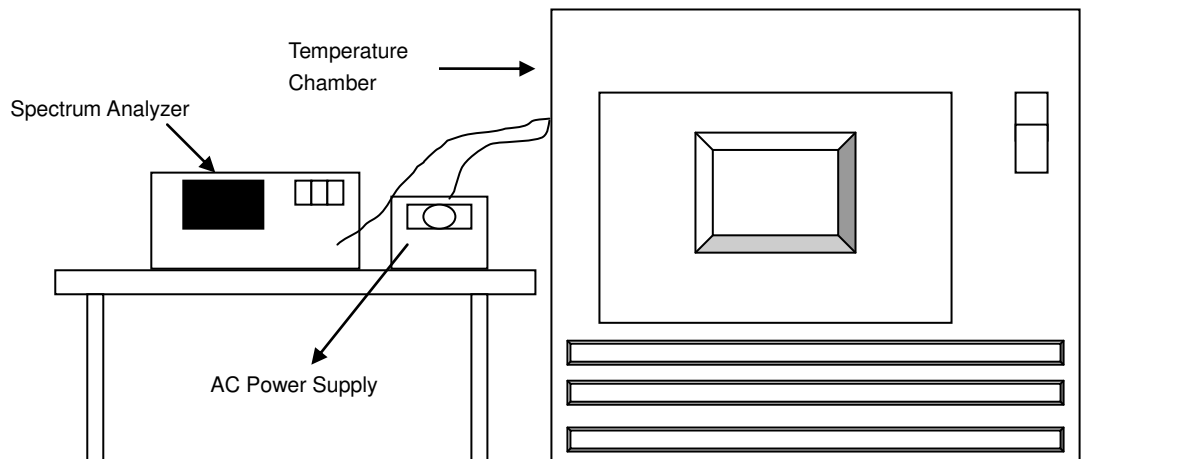

4.4.3 Test Instruments

Refer to section 4.1.2 to get information of above instrument.

4.4.4 Test Procedure

- The EUT was placed inside the environmental test chamber and powered by nominal AC voltage.
- Turn the EUT on and couple its output to a spectrum analyzer.
- Turn the EUT off and set the chamber to the highest temperature specified.
- Allow sufficient time (approximately 30 min) for the temperature of the chamber to stabilize, turn the EUT on and measure the operating frequency after 2, 5, and 10 Minutes.
- Repeat step 2 and 3 with the temperature chamber set to the lowest temperature.
- The test chamber was allowed to stabilize at +20 degree C for a minimum of 30 Minutes. The supply voltage was then adjusted on the EUT from 85% to 115% and the frequency record.

4.4.5 Deviation from Test Standard

No deviation.

4.4.6 EUT Operating Condition

Set the EUT transmit at un-modulation mode to test frequency stability.

4.4.7 Test Results

Frequency Stability Versus Temp.									
Operating Frequency: 5745 MHz									
TEMP. (°C)	Power Supply (Vac)	0 Minute		2 Minute		5 Minute		10 Minute	
		Measured Frequency (MHz)	Pass/Fail	Measured Frequency (MHz)	Pass/Fail	Measured Frequency (MHz)	Pass/Fail	Measured Frequency (MHz)	Pass/Fail
50	120	5745.0202	Pass	5745.015	Pass	5745.0172	Pass	5745.0202	Pass
40	120	5744.9828	Pass	5744.9852	Pass	5744.983	Pass	5744.9859	Pass
30	120	5744.9893	Pass	5744.9866	Pass	5744.9867	Pass	5744.9888	Pass
20	120	5745.0166	Pass	5745.0146	Pass	5745.0122	Pass	5745.0129	Pass
10	120	5745.0211	Pass	5745.0239	Pass	5745.0226	Pass	5745.0209	Pass
0	120	5745.0146	Pass	5745.0165	Pass	5745.0123	Pass	5745.0146	Pass
-10	120	5744.9698	Pass	5744.9694	Pass	5744.9706	Pass	5744.9737	Pass
-20	120	5744.9759	Pass	5744.9797	Pass	5744.975	Pass	5744.9771	Pass
-30	120	5744.9906	Pass	5744.9889	Pass	5744.9892	Pass	5744.9893	Pass

Frequency Stability Versus Voltage									
Operating Frequency: 5745 MHz									
TEMP. (°C)	Power Supply (Vac)	0 Minute		2 Minute		5 Minute		10 Minute	
		Measured Frequency (MHz)	Pass/Fail	Measured Frequency (MHz)	Pass/Fail	Measured Frequency (MHz)	Pass/Fail	Measured Frequency (MHz)	Pass/Fail
20	138	5745.0173	Pass	5745.0154	Pass	5745.0129	Pass	5745.0127	Pass
	120	5745.0166	Pass	5745.0146	Pass	5745.0122	Pass	5745.0129	Pass
	102	5745.0156	Pass	5745.0149	Pass	5745.0129	Pass	5745.0127	Pass

4.5 6dB Bandwidth Measurement

4.5.1 Limits of 6dB Bandwidth Measurement

The minimum of 6dB Bandwidth Measurement is 0.5MHz.

4.5.2 Test Setup

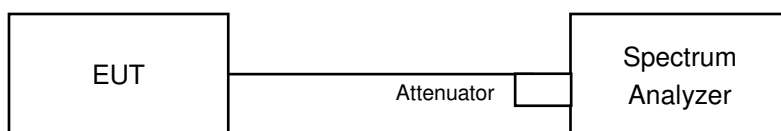

4.5.3 Test Instruments

Refer to section 4.1.2 to get information of above instrument.

4.5.4 Test Procedure

MEASUREMENT PROCEDURE REF

- Set resolution bandwidth (RBW) = 100kHz
- Set the video bandwidth (VBW) $\geq 3 \times$ RBW, Detector = Peak.
- Trace mode = max hold.
- Sweep = auto couple.
- Measure the maximum width of the emission that is constrained by the frequencies associated with the two amplitude points (upper and lower) that are attenuated by 6 dB relative to the maximum level measured in the fundamental emission

4.5.5 Deviation from Test Standard

No deviation.

4.5.6 EUT Operating Condition

The software provided by client to enable the EUT under transmission condition continuously at lowest, middle and highest channel frequencies individually.

4.5.7 Test Results

802.11a

Channel	Frequency (MHz)	6dB Bandwidth (MHz)	Minimum Limit (MHz)	Pass / Fail
149	5745	15.16	0.5	Pass
157	5785	15.20	0.5	Pass
165	5825	15.17	0.5	Pass

802.11n (HT20)

Channel	Frequency (MHz)	6dB Bandwidth (MHz)		Minimum Limit (MHz)	Pass / Fail
		Chain 0	Chain 1		
149	5745	15.16	15.22	0.5	Pass
157	5785	15.15	15.21	0.5	Pass
165	5825	15.20	15.18	0.5	Pass

802.11n (HT40)

Channel	Frequency (MHz)	6dB Bandwidth (MHz)		Minimum Limit (MHz)	Pass / Fail
		Chain 0	Chain 1		
151	5755	35.27	35.76	0.5	Pass
159	5795	35.20	35.46	0.5	Pass

Spectrum Plot of Worst Value

802.11a_Chain 1 / CH149

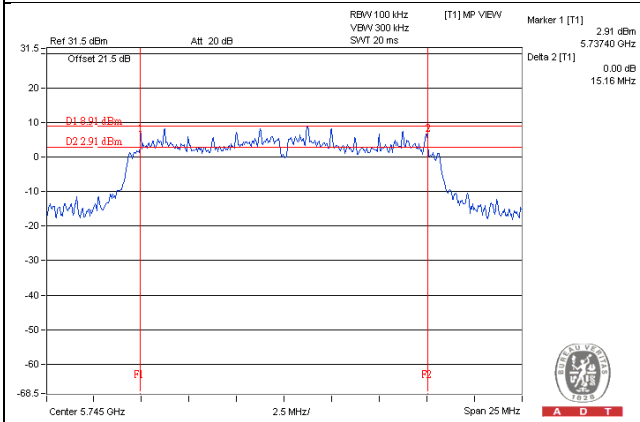

802.11n (HT20)_Chain 0 / CH157

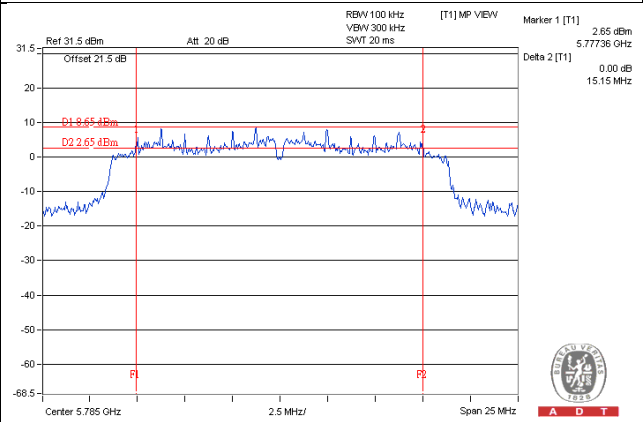

802.11n (HT40)_Chain 0 / CH159

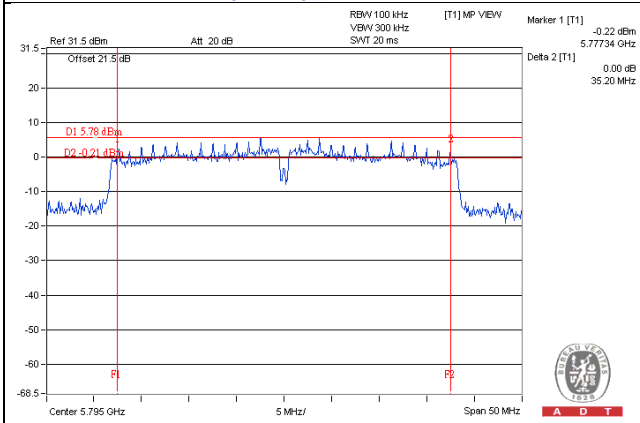

5 Pictures of Test Arrangements

Please refer to the attached file (Test Setup Photo).



Annex A- Radiated Out of Band Emisison (OOBE) Measurement (For U-NII-3 band)

802.11a

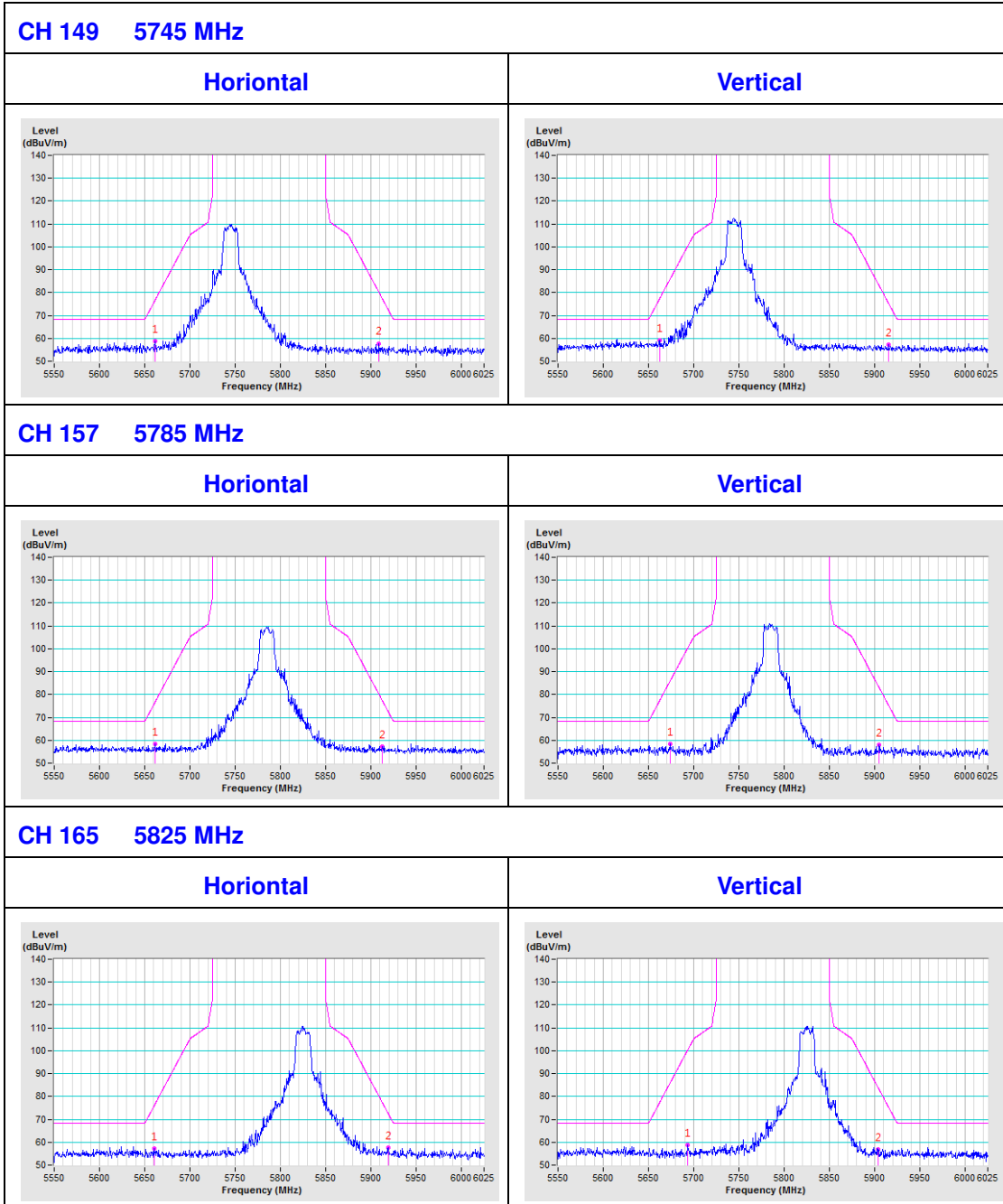

802.11n (HT20)

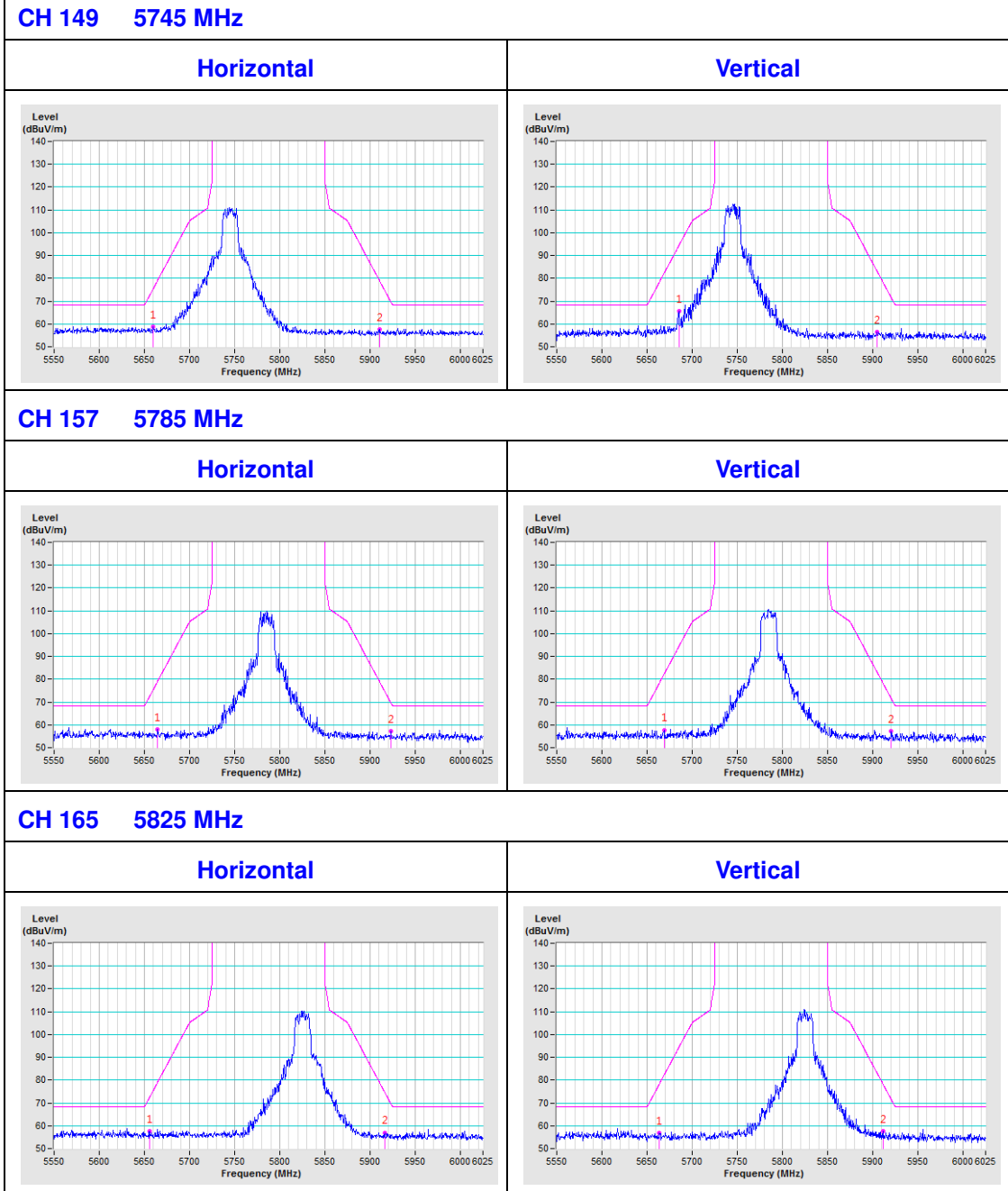

802.11n (HT40)

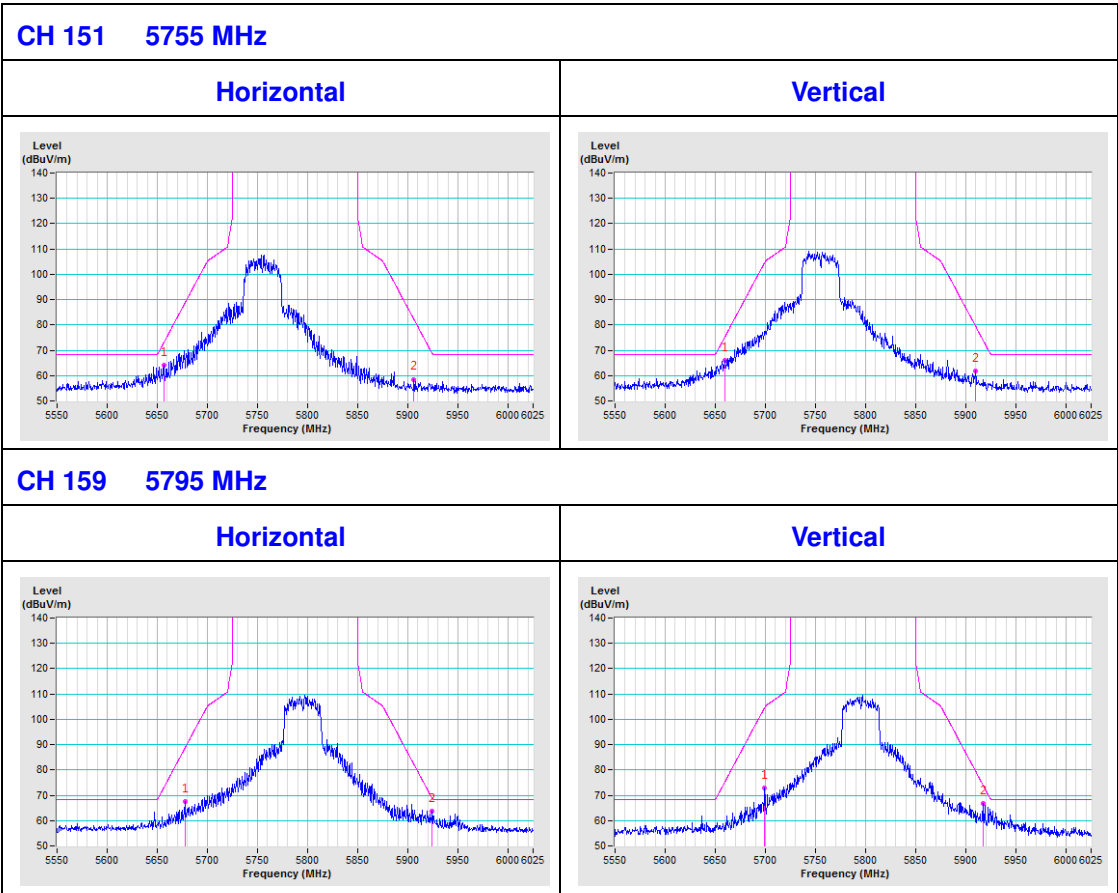



Appendix – Information on the Testing Laboratories

We, Bureau Veritas Consumer Products Services (H.K.) Ltd., Taoyuan Branch, were founded in 1988 to provide our best service in EMC, Radio, Telecom and Safety consultation. Our laboratories are accredited and approved according to ISO/IEC 17025.

If you have any comments, please feel free to contact us at the following:

Linko EMC/RF Lab

Tel: 886-2-26052180

Fax: 886-2-26051924

Hsin Chu EMC/RF/Telecom Lab

Tel: 886-3-6668565

Fax: 886-3-6668323

Hwa Ya EMC/RF/Safety Lab

Tel: 886-3-3183232

Fax: 886-3-3270892

Email: service.adt@tw.bureauveritas.com

Web Site: www.bureauveritas-adt.com

The address and road map of all our labs can be found in our web site also.

--- END ---