



## PDM245115H-CS2

### 4-Port Directional H/V MIMO Antenna 2400-2500 MHz / 5150-5900 MHz

The PDM245115H-CS2 antenna is a four-port directional antenna for use in 802.11 MIMO applications. Designed for low side lobe and front-to-back performance, the antenna is an excellent choice for high density Wi-Fi applications where adjacent antenna interference is of concern. Equipped with two vertically polarized ports and two horizontally polarized ports, the antenna takes advantage of both polarization and spatial separation to mitigate multipath issues.

Enclosed in a compact/low profile polycarbonate radome and equipped with an articulating arm that can be affixed to a mast or anchored directly to a vertical surface, the antenna can be oriented to take full advantage of the antenna's directionality. Uniform and symmetrical radiation patterns provide high-level signal density into defined coverage zones. This antenna greatly enhances the performance of 802.11 systems where physical obstructions are anticipated. The dual band frequency coverage means that a single type of antenna can be deployed with any MIMO radio in the 2.4-2.5 GHz and 5.15-5.9 GHz bands.

#### FEATURES AND BENEFITS

- 802.11n MIMO
- Wide band 2.4-2.5 GHz and 5.15-5.9 GHz performance
- Vertically and horizontally polarized radiating elements in a single solution
- Equitable for both indoor and outdoor solutions
- Low profile
- Multipath mitigation
- Lower adjacent antenna interference
- Frequency diplexed dual polarized radiators

#### APPLICATIONS

- High density Wi-Fi
- Stadiums, arenas, convention centers
- Transport terminals
- Campuses
- Outdoor networks

#### ELECTRICAL SPECIFICATIONS

Model Number	PDM245115H-CS2		
Cisco Part Number	AIR-ANT2513P4M-NS		
Cisco Manufacturing Number	07-100553-01		
Number of Ports	4		
Operating Frequency (MHz)	2400-2500	5150-5700	5700-5900
VSWR - Max	<1.6:1	<2.0:1	<1.5:1
Gain (dBi)	13	13	
Nominal Impedance (Ohms)	50		
Vertical Plane 3 dB Beamwidth	35°		
Horizontal Plane 3 dB Beamwidth	35°		
Sidelobes (dB)	< 8	< 12	
Front-to-Back Ratio (dB)	> 15	> 15	

## ELECTRICAL SPECIFICATIONS

Vertical Plane 3 dB Beamwidth	33°	27°
Horizontal Plane 3 dB Beamwidth	31°	31°
Sidelobes - Azimuth (dB)	-20	-20
Sidelobes - Elevation (dB)	-10	-15
Front-to-Back Ratio (dB)	35	-

## MECHANICAL SPECIFICATIONS

Dimensions - mm (inches)	507.0 x 368 x 21.1 (20.0 x 14.5 x 0.8)
Weight - kg (lbs.) (no brackets)	2.3 (5.1)
Radome Material	Polycarbonate, UL94-V0, medium gray

## ENVIRONMENTAL SPECIFICATIONS

Operating Environment (Indoor or Outdoor)	Indoor and Outdoor
Operating Temperature - °C (°F)	-40 to +70°C (-40 to +158°F)
Storage Temperature - °C (°F)	-40 to +85°C (-40 to +185°F)
Ingress Protection Rating	IP67
Flammability Rating	UL 94V0 Materials
Material Substance Compliance	RoHS

## CONFIGURATION

PART NUMBER	CONNECTOR
PDM245115H-CS2	Type N Female (x4)

# MECHANICAL DRAWING

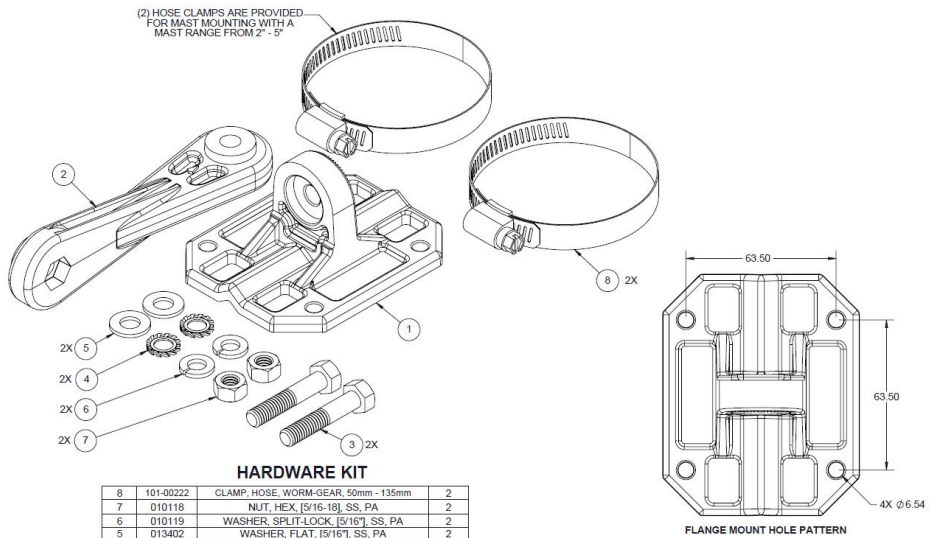
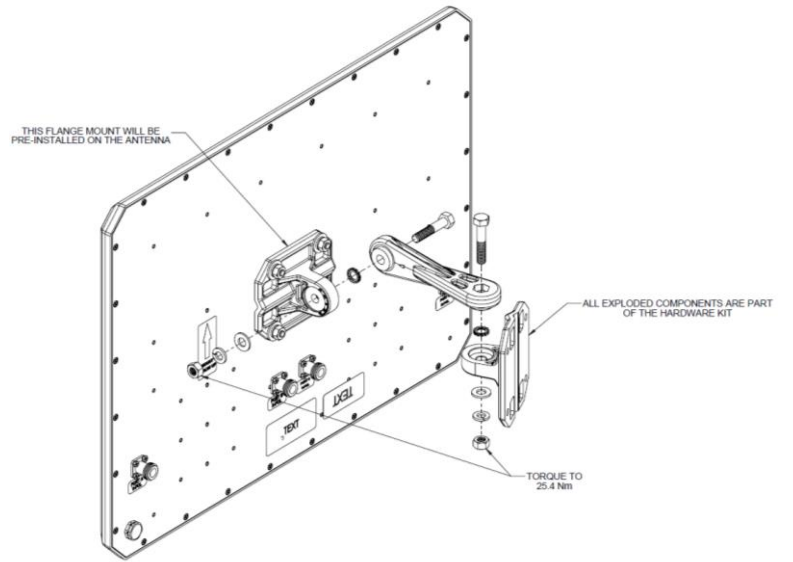
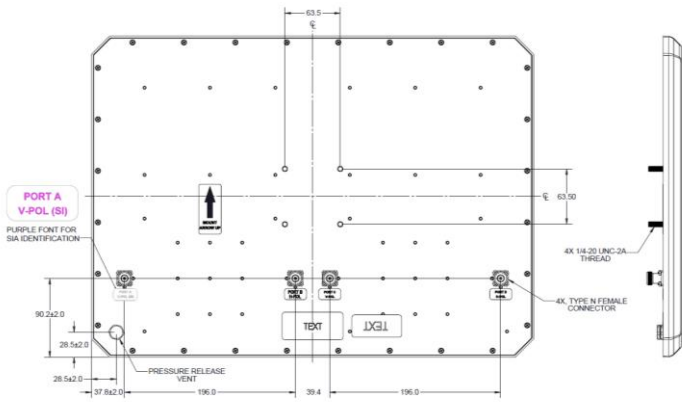
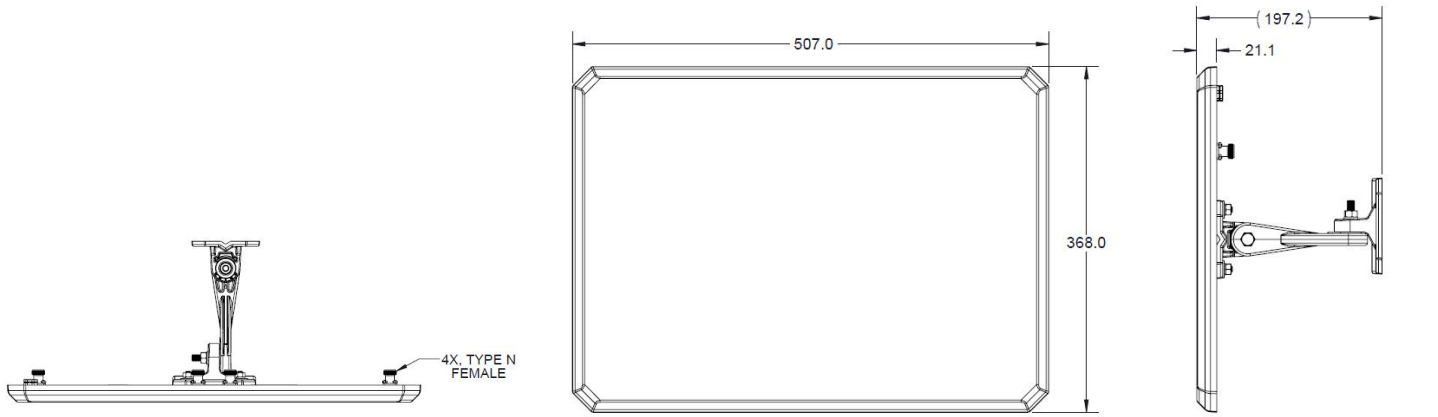

**HARDWARE KIT**

8	101-00222	CLAMP, HOSE, WORM-GEAR, 50mm - 135mm	2
7	010118	NUT, HEX, [5/16-18], SS, PA	2
6	010119	WASHER, SPLIT-LOCK, [5/16], SS, PA	2
5	013402	WASHER, FLAT, [5/16], SS, PA	2
4	017845	WASHER, EXT OL SERRATED, [M8], SS, PA	2
3	017844	SCREW, HHC, [5/16-18 X 1-5/8], SS, PA	2
2	112-00023	ARM, HDMNT	1
1	112-00022	FLANGE, HDMNT	1
ITEM NO.	PART NUMBER	DESCRIPTION	QTY

# MECHANICAL DRAWING

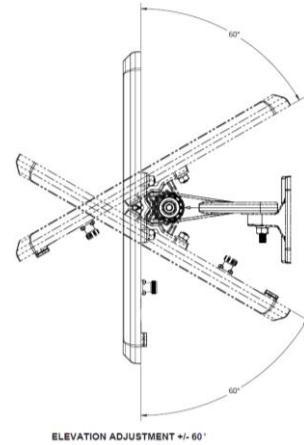
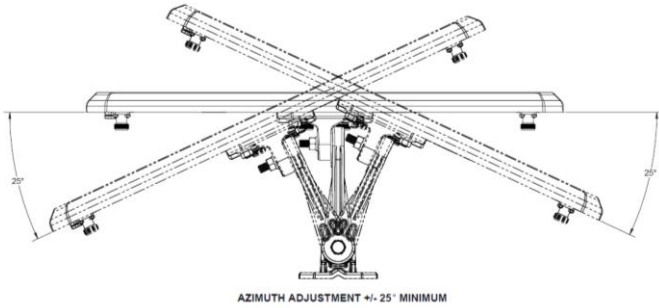

# RADIATION PATTERNS - PORT A

2400 MHz

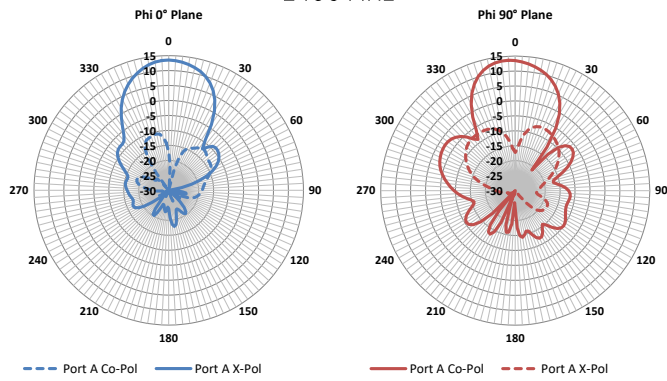

2500 MHz

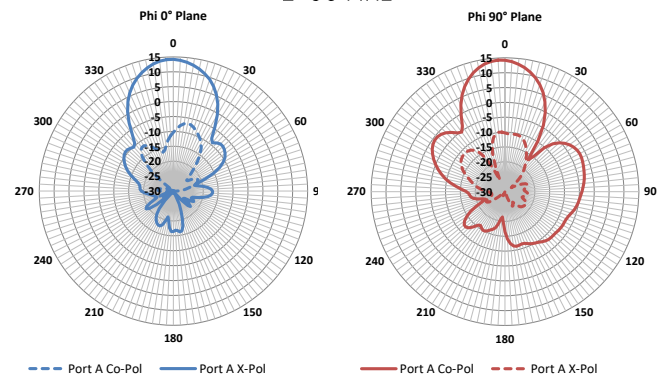

5150 MHz

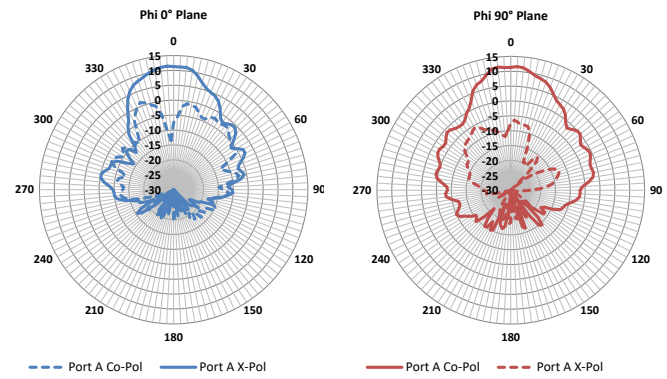

5470 MHz

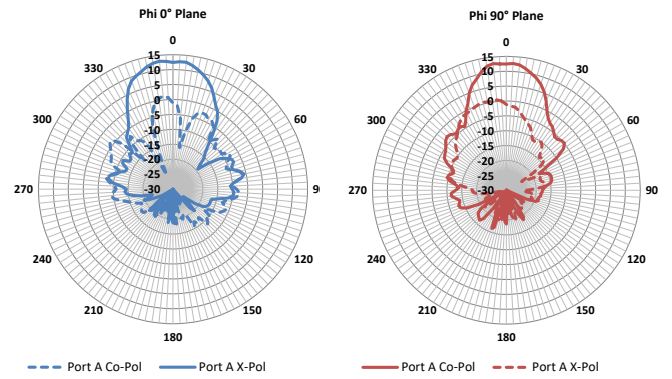

5900 MHz

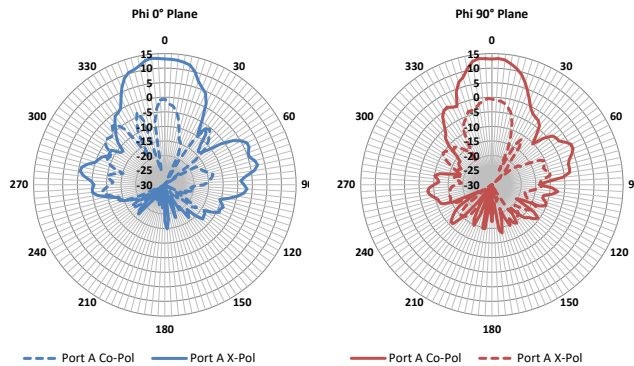

# RADIATION PATTERNS - PORT B

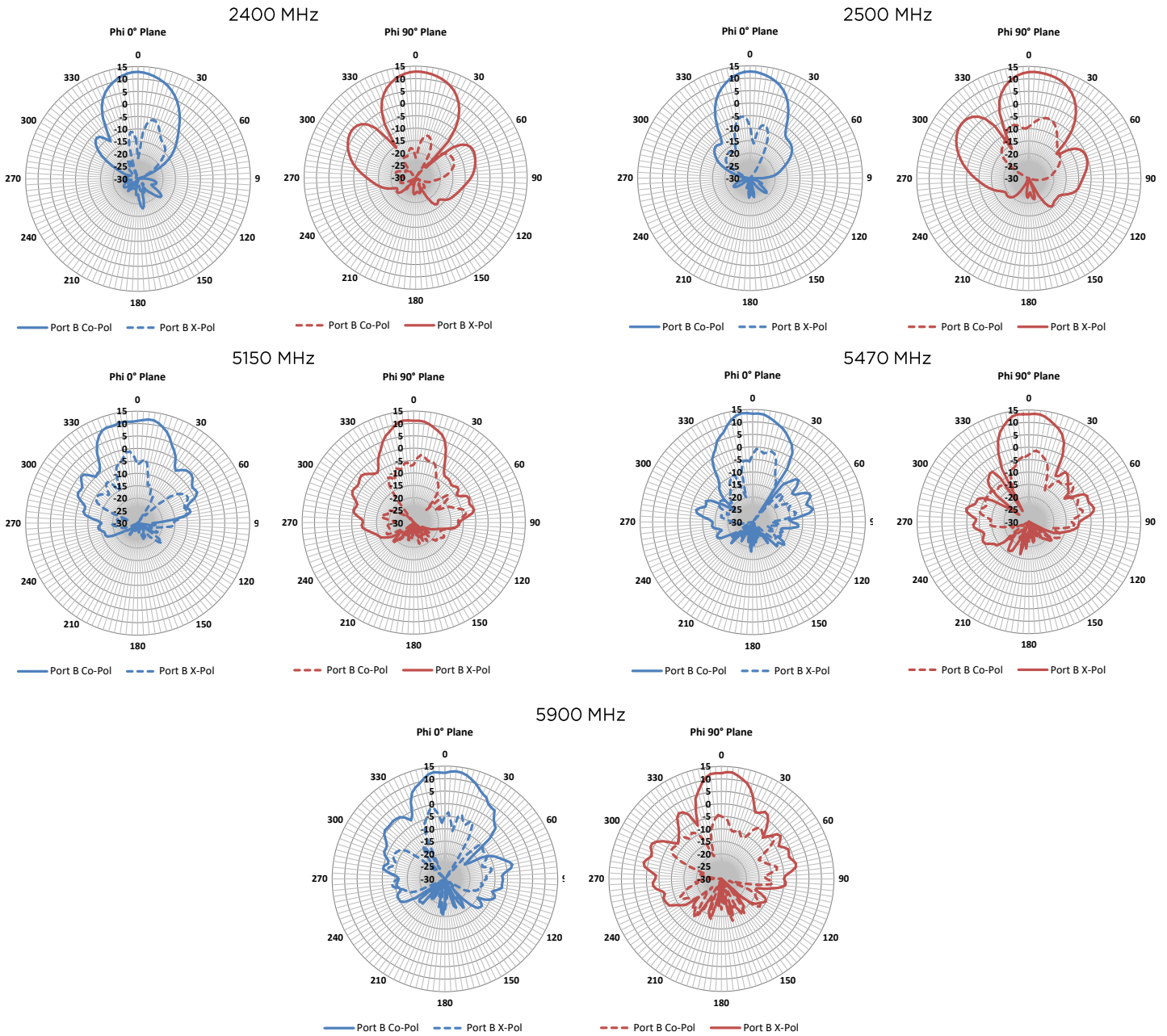



# RADIATION PATTERNS - PORT C

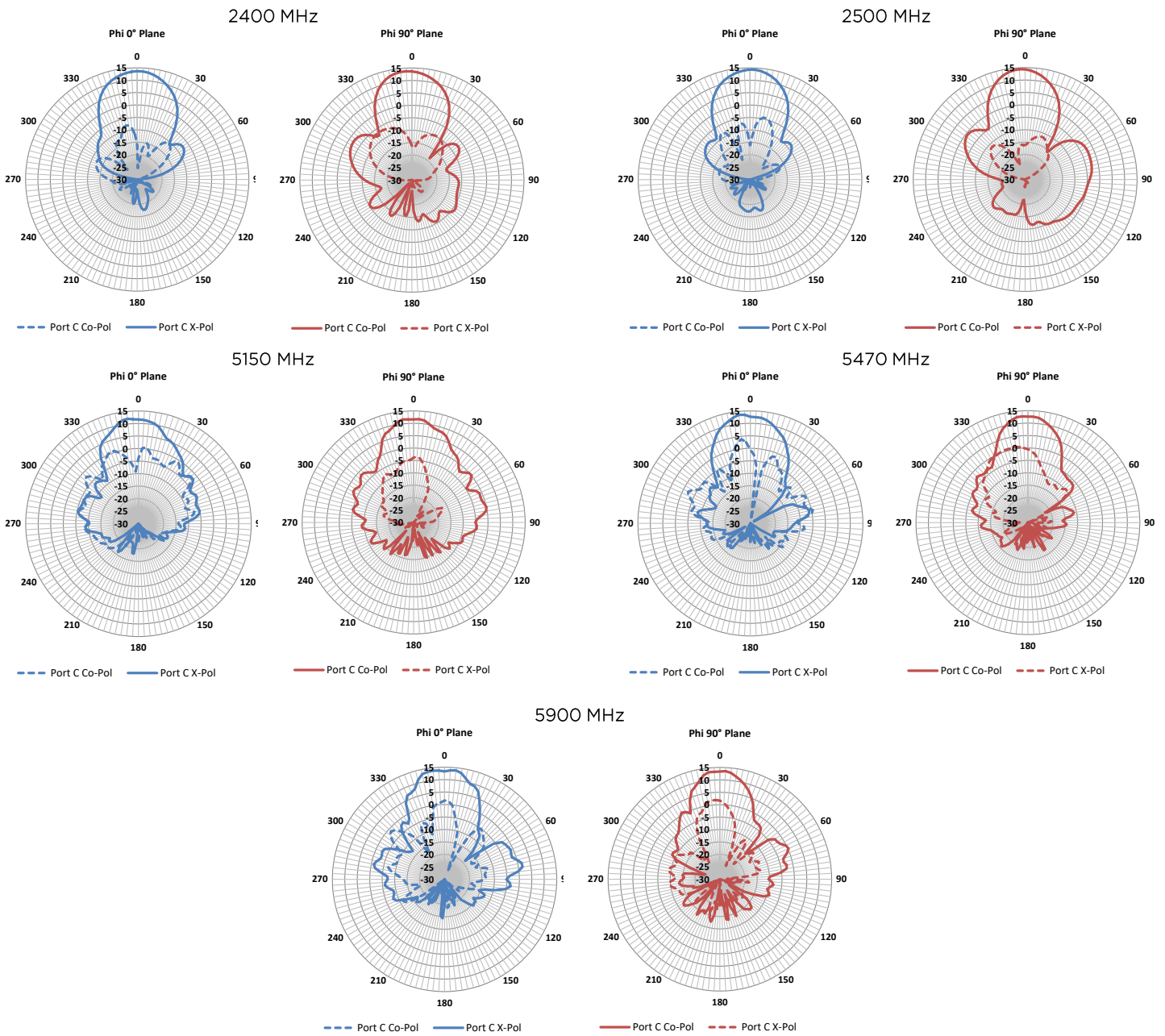

# RADIATION PATTERNS - PORT D

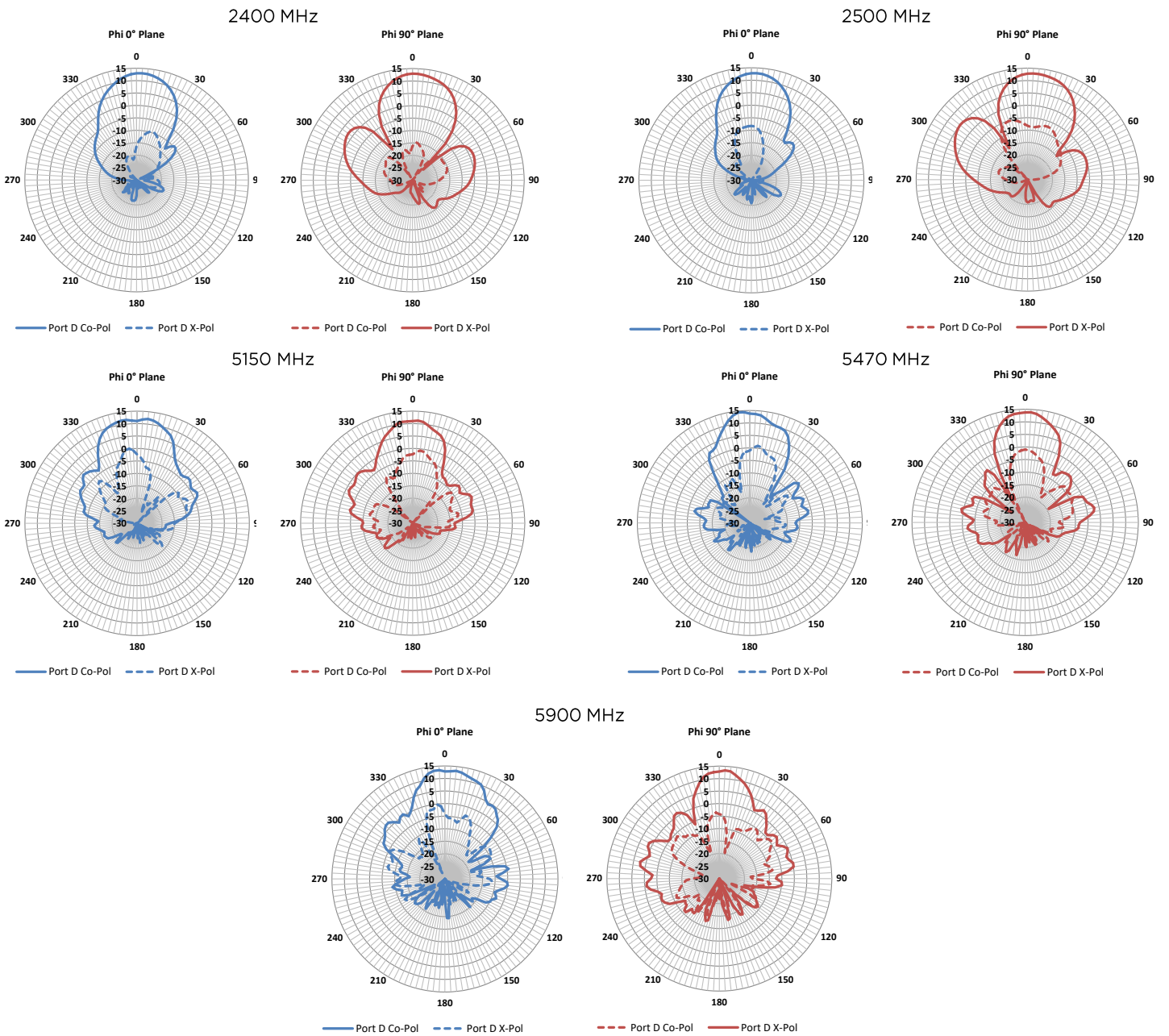

---

Company Address: TE Connectivity, 3101 Fulling Mill Road, Middletown, PA, 17057, USA

### TE TECHNICAL SUPPORT CENTER

USA:	+1 (800) 522-6752
Canada:	+1 (905) 475-6222
Mexico:	+52 (0) 55-1106-0800
Latin/S. America:	+54 (0) 11-4733-2200
Germany:	+49 (0) 6251-133-1999
UK:	+44 (0) 800-267666
France:	+33 (0) 1-3420-8686
Netherlands:	+31 (0) 73-6246-999
China:	+86 (0) 400-820-6015

### te.com

TE, and TE connectivity (logo) are trademarks owned or licensed by the TE Connectivity Ltd. family of companies. All other logos, products and/or company names referred to herein might be trademarks of their respective owners.

The information given herein, including drawings, illustrations and schematics which are intended for illustration purposes only, is believed to be reliable. However, TE Connectivity makes no warranties as to its accuracy or completeness and disclaims any liability in connection with its use. TE Connectivity's obligations shall only be as set forth in TE Connectivity's Standard Terms and Conditions of Sale for this product and in no case will TE Connectivity be liable for any incidental, indirect or consequential damages arising out of the sale, resale, use or misuse of the product. Users of TE Connectivity products should make their own evaluation to determine the suitability of each such product for the specific application.

TE Connectivity warrants to the original end user customer of its products that its products are free from defects in material and workmanship. Subject to conditions and limitations TE Connectivity will, at its option, either repair or replace any part of its products that prove defective because of improper workmanship or materials. This limited warranty is in force for the useful lifetime of the original end product into which the TE Connectivity product is installed. Useful lifetime of the original end product may vary but is not warranted to exceed one (1) year from the original date of the end product purchase.

©2022 TE Connectivity. All Rights Reserved.

01/23 Original