



# FCC RF Test Report

**APPLICANT** : Motorola Mobility LLC  
**EQUIPMENT** : Mobile Cellular Phone  
**BRAND NAME** : Motorola  
**MODEL NAME** : XT1926-6, XT1926-7  
**FCC ID** : IHDT56WL4  
**STANDARD** : FCC Part 15 Subpart C §15.225  
**CLASSIFICATION** : (DXX) Low Power Communication Device Transmitter

The product was received on Dec. 27, 2017 and testing was completed on Jul. 12, 2017. We, Sporton International (Kunshan) Inc., would like to declare that the tested sample has been evaluated in accordance with the test procedures and has been in compliance with the applicable technical standards.

The test results in this report apply exclusively to the tested model / sample. Without written approval of Sporton International (Kunshan) Inc., the test report shall not be reproduced except in full.



Approved by: James Huang / Manager

**Sporton International (Kunshan) Inc.**  
No.3-2 Ping-Xiang Rd, Kunshan Development Zone Kunshan City Jiangsu Province 215335  
China



TABLE OF CONTENTS

TABLE OF CONTENTS .....2
REVISION HISTORY .....3
SUMMARY OF THE TEST RESULT .....4
1. GENERAL INFORMATION .....5
1.1 Applicant .....5
1.2 Manufacturer .....5
1.3 Product Feature of Equipment Under Test .....5
1.4 Product Specification of Equipment Under Test .....6
1.5 Specification of Accessory .....7
1.6 Modification of EUT .....8
1.7 Testing Location .....8
1.8 Applicable Standards .....9
2. TEST CONFIGURATION OF EQUIPMENT UNDER TEST .....10
2.1 Descriptions of Test Mode .....10
2.2 Connection Diagram of Test System .....10
2.3 Table for Supporting Units .....11
2.4 EUT Operation Test Setup .....11
3. TEST RESULTS .....12
3.1 AC Power Line Conducted Emissions Measurement .....12
3.2 20dB and 99% OBW Spectrum Bandwidth Measurement .....14
3.3 Frequency Stability Measurement .....15
3.4 Field Strength of Fundamental Emissions and Mask Measurement .....16
3.5 Radiated Emissions Measurement .....18
3.6 Antenna Requirements .....21
4. LIST OF MEASURING EQUIPMENT .....22
APPENDIX A. TEST RESULTS OF CONDUCTED EMISSION TEST
APPENDIX B. TEST RESULTS OF CONDUCTED TEST ITEMS
B1. Test Result of 20dB Spectrum Bandwidth
B2. Test Result of Frequency Stability
APPENDIX C. TEST RESULTS OF RADIATED TEST ITEMS
C1. Test Result of Field Strength of Fundamental Emissions
C2. Results of Radiated Emissions (9 kHz~30MHz)
C3. Results of Radiated Emissions (30MHz~1GHz)
APPENDIX D. SETUP PHOTOGRAPHS





### SUMMARY OF THE TEST RESULT

Applied Standard: 47 CFR FCC Part 15 Subpart C				
Part	FCC Rule	Description of Test	Result	Remark
3.1	15.207	AC Power Line Conducted Emissions	Complies	Under limit 11.60 dB at 0.150MHz
3.2	15.215(c)	20dB Spectrum Bandwidth	Complies	-
	-	99% OBW Spectrum Bandwidth	Complies	-
3.3	15.225(e)	Frequency Stability	Complies	-
3.4	15.225(a)(b)(c)	Field Strength of Fundamental Emissions	Complies	53.98 dBuV/m at 13.560 MHz
3.5	15.225(d)	Radiated Emissions	Complies	Under limit
	15.209			3.06 dB at 40.670 MHz for Quasi-Peak
3.6	15.203	Antenna Requirements	Complies	-

Test Items	Uncertainty	Remark
AC Power Line Conducted Emissions	±2.3dB	Confidence levels of 95%
Radiated Emissions (30MHz~1000MHz)	±4.8dB	Confidence levels of 95%



# 1. GENERAL INFORMATION

## 1.1 Applicant

Motorola Mobility LLC  
222 W, Merchandise Mart Plaza, Chicago IL 60654 USA

## 1.2 Manufacturer

Motorola Mobility LLC  
222 W, Merchandise Mart Plaza, Chicago IL 60654 USA

## 1.3 Product Feature of Equipment Under Test

Product Feature	
Equipment	Mobile Cellular Phone
Brand Name	Motorola
Model Name	XT1926-6, XT1926-7
FCC ID	IHDT56WL4
EUT supports Radios application	GSM/GPRS/EGPRS/WCDMA/HSPA/DC-HSDPA/ HSPA+ /LTE/NFC WLAN 2.4GHz 802.11b/g/n HT20/ WLAN 5GHz 802.11a/n HT20/HT40/ WLAN 5GHz 802.11ac VHT20/VHT40/VHT80/ Bluetooth v3.0 + EDR/Bluetooth v4.0 LE/ Bluetooth v4.1 LE/Bluetooth v4.2 LE / Bluetooth v5.0 LE
SN/IMEI Code	Conducted: 351853090015717/351853090015725 Conduction: NTEL1B0009 Radiation: 351853090016053/351853090016061
HW Version	DVT1B
SW Version	evert_n-userdebug 8.0.0 OPW27.88 1825 intcfg,test-keys
EUT Stage	Identical Prototype

**Remark:**

1. The above EUT's information was declared by manufacturer. Please refer to the specifications or user's manual for more detailed description.
2. There are two types of EUT: sample 1 (XT1926-7) is dual SIM card, sample 2 (XT1926-6) is single SIM card. Except the SIM card slot, all the others are the same. The difference has no influence on RF test, we only choose sample 1 to perform full test.



### 1.4 Product Specification of Equipment Under Test

Standards-related Product Specification	
Tx/Rx Frequency Range	13.553 ~ 13.567MHz
Channel Number	1
20dBW	2.49 KHz
99%OBW	2.11 KHz
Antenna Type	Loop Antenna
Type of Modulation	ASK

**Remark:** The above EUT's information was declared by manufacturer. Please refer to the specifications or user's manual for more detailed description.



### 1.5 Specification of Accessory

Specification of Accessory				
AC Adapter 1(US)	Brand Name	Motorola (Salom)	Model Name	SC-22
	Power Rating	I/P: 100-240 Vac, 500mA, O/P: 5Vdc,3000mA or 9Vdc,1600mA or 12Vdc,1200mA		
AC Adapter 1(EU)	Brand Name	Motorola (Salom)	Model Name	SC-23
	Power Rating	I/P: 100-240 Vac, 500mA, O/P: 5Vdc,3000mA or 9Vdc,1600mA or 12Vdc,1200mA		
AC Adapter 1(UK)	Brand Name	Motorola (Salom)	Model Name	SC-24
	Power Rating	I/P: 100-240 Vac, 500mA, O/P: 5Vdc,3000mA or 9Vdc,1600mA or 12Vdc,1200mA		
AC Adapter 1(IN)	Brand Name	Motorola (Salom)	Model Name	SC-25
	Power Rating	I/P: 100-240 Vac, 500mA, O/P: 5Vdc,3000mA or 9Vdc,1600mA or 12Vdc,1200mA		
AC Adapter 1(AU)	Brand Name	Motorola (Salom)	Model Name	SC-26
	Power Rating	I/P: 100-240 Vac, 500mA, O/P: 5Vdc,3000mA or 9Vdc,1600mA or 12Vdc,1200mA		
AC Adapter 1(AR)	Brand Name	Motorola (Salom)	Model Name	SC-27
	Power Rating	I/P: 100-240 Vac, 500mA, O/P: 5Vdc,3000mA or 9Vdc,1600mA or 12Vdc,1200mA		
AC Adapter 2(US)	Brand Name	Motorola (Chenyang)	Model Name	SC-22
	Power Rating	I/P: 100-240 Vac, 500mA, O/P: 5Vdc,3000mA or 9Vdc,1600mA or 12Vdc,1200mA		
AC Adapter 2(EU)	Brand Name	Motorola (Chenyang)	Model Name	SC-23
	Power Rating	I/P: 100-240 Vac, 500mA, O/P: 5Vdc,3000mA or 9Vdc,1600mA or 12Vdc,1200mA		
AC Adapter 2(UK)	Brand Name	Motorola (Chenyang)	Model Name	SC-24
	Power Rating	I/P: 100-240 Vac, 500mA, O/P: 5Vdc,3000mA or 9Vdc,1600mA or 12Vdc,1200mA		
AC Adapter 2(IN)	Brand Name	Motorola (Chenyang)	Model Name	SC-25
	Power Rating	I/P: 100-240 Vac, 500mA, O/P: 5Vdc,3000mA or 9Vdc,1600mA or 12Vdc,1200mA		
AC Adapter 2(AU)	Brand Name	Motorola (Chenyang)	Model Name	SC-26
	Power Rating	I/P: 100-240 Vac, 500mA, O/P: 5Vdc,3000mA or 9Vdc,1600mA or 12Vdc,1200mA		
AC Adapter 2(AR)	Brand Name	Motorola (chenyang)	Model Name	SC-27
	Power Rating	I/P: 100-240 Vac, 500mA, O/P: 5Vdc,3000mA or 9Vdc,1600mA or 12Vdc,1200mA		
Battery	Brand Name	Motorola (ATL)	Model Name	JT40
	Power Rating	3.8Vdc,3200mAh	Type	Li-ion Polymer
Earphone 1	Brand Name	Motorola (Jiahe)	Model Name	LS-118M-12
	Signal Line Type	1.2 meter, non-shielded cable, without ferrite core		
Earphone 2	Brand Name	Motorola (Lianyun)	Model Name	TS910A-38AMS01WHR-M
	Signal Line Type	1.2 meter, non-shielded cable, without ferrite core		
USB Cable	Brand Name	Motorola (Liqi)	Model Name	L32B-053000100-ALL
	Signal Line Type	1.0 meter, shielded cable, without ferrite core		



### 1.6 Modification of EUT

No modifications are made to the EUT during all test items.

### 1.7 Testing Location

Sporton International (Kunshan) Inc. is accredited to ISO 17025 by National Voluntary Laboratory Accreditation Program (NVLAP code: 600155-0) and the FCC designation No is CN5013.

<b>Test Site</b>	Sporton International (Kunshan) Inc.		
<b>Test Site Location</b>	No.3-2 Ping-Xiang Rd, Kunshan Development Zone Kunshan City Jiangsu Province 215335 China TEL : +86-512-57900158 FAX : +86-512-57900958		
<b>Test Site No.</b>	<b>Sporton Site No.</b>		<b>FCC Registration No.</b>  CN5013
	TH01-KS	CO01-KS	
<b>Test Engineer</b>	Silent Hai	Eko Guan	
<b>Temperature</b>	21~25°C	22~24°C	
<b>Relative Humidity</b>	51~55%	40~42%	

Sporton International (Shenzhen) Inc. is accredited to ISO 17025 by National Voluntary Laboratory Accreditation Program (NVLAP code: 600156-0) and the FCC designation No is CN5019.

<b>Test Site</b>	Sporton International (Shenzhen) Inc.		
<b>Test Site Location</b>	No. 3 Bldg the third floor of south, Shahe River west, Fengzeyuan Warehouse, Nanshan District Shenzhen City Guangdong Province 518055 China TEL: +86-755-3320-2398		
<b>Test Site No.</b>	<b>Sporton Site No.</b>		<b>FCC Registration No.</b>  577730
	03CH01-SZ		
<b>Test Engineer</b>	Vikki Peng		
<b>Temperature</b>	24~25°C		
<b>Relative Humidity</b>	48~49%		

**Note:** The test site complies with ANSI C63.4 2014 requirement.



## 1.8 Applicable Standards

According to the specifications of the manufacturer, the EUT must comply with the requirements of the following standards:

- ♦ FCC Part 15 Subpart C §15.225
- ♦ ANSI C63.10-2013

## 2. TEST CONFIGURATION OF EQUIPMENT UNDER TEST

### 2.1 Descriptions of Test Mode

Investigation has been done on all the possible configurations for searching the worst cases.

The following table is a list of the test modes shown in this test report.

Test Items	
AC Power Line Conducted Emissions	Field Strength of Fundamental Emissions
20dB Spectrum Bandwidth	Frequency Stability
Radiated Emissions 9kHz~30MHz	Radiated Emissions 30MHz~1GHz

The EUT pre-scanned in four NFC type, A, B, F, V. The worst type (type F) was recorded in this report. Pre-scanned tests, X, Y, Z in three orthogonal panels to determine the final configuration (Y plane as worst plane) from all possible combinations.

### 2.2 Connection Diagram of Test System

#### <AC Conducted Emissions>

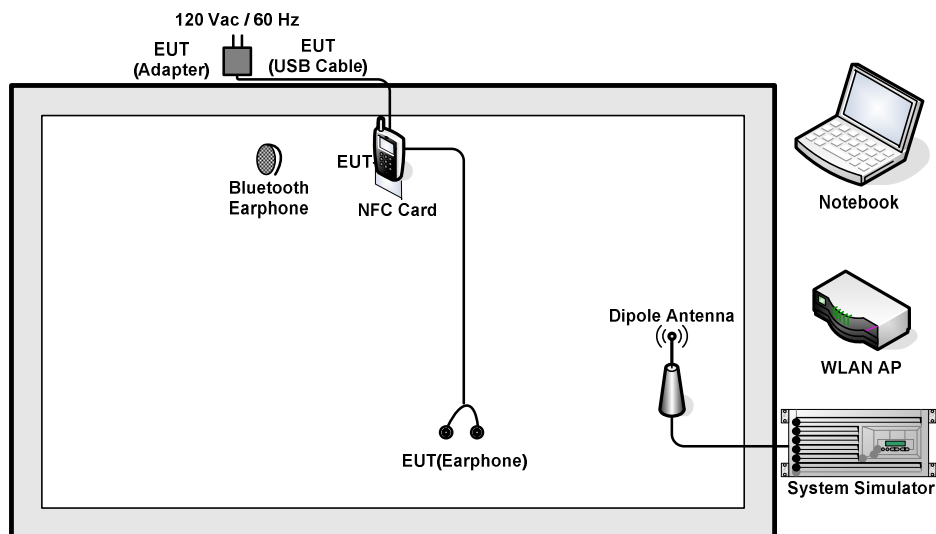

< For Fundamental Emissions and Mask and Radiated Emissions Measurement >

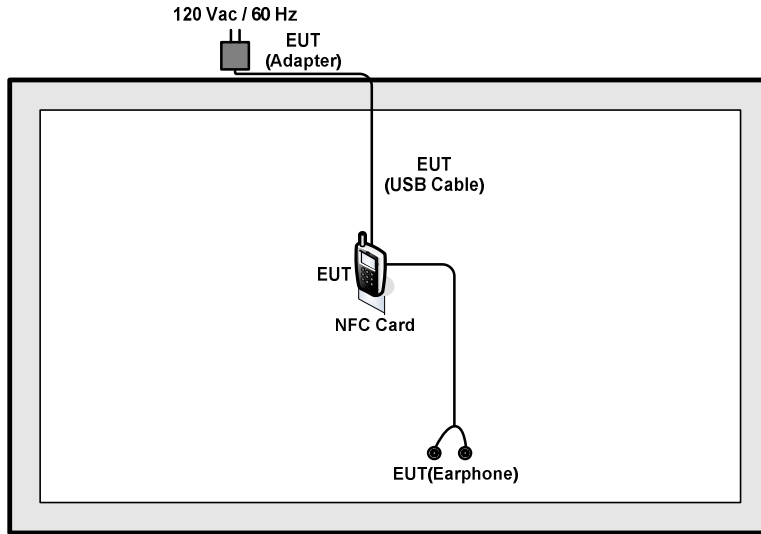

### 2.3 Table for Supporting Units

Support Unit	Manufacturer	Model	FCC ID
System Simulator	R&S	CMU 200	N/A
Router	D-link	DIR-855	KA2DIR855A2
Bluetooth Earphone	Lenovo	LBH308	N/A
Notebook	Lenovo	G480	N/A
NFC Card	N/A	N/A	N/A
SD Card	Kingston	8GB	N/A

### 2.4 EUT Operation Test Setup

The EUT was programmed to be in continuously transmitting mode.

The ancillary equipment, NFC card, is used to make the EUT (NFC) continuously transmit at 13.56MHz and is placed around 3 cm gap to the EUT.



### 3. TEST RESULTS

#### 3.1 AC Power Line Conducted Emissions Measurement

##### 3.1.1 Limit of AC Conducted Emission

For equipment that is designed to be connected to the public utility (AC) power line, the radio frequency voltage that is conducted back onto the AC power line on any frequency or frequencies within the band 150 kHz to 30 MHz shall not exceed the limits in the following table.

Frequency of Emission (MHz)	Conducted Limit (dBµV)	
	Quasi-Peak	Average
0.15-0.5	66 to 56*	56 to 46*
0.5-5	56	46
5-30	60	50

\*Decreases with the logarithm of the frequency.

For terminal test result, the testing follows FCC KDB 174176.

##### 3.1.2 Measuring Instruments

See list of measuring instruments of this test report.

##### 3.1.3 Test Procedures

1. The EUT was placed 0.4 meter from the conducting wall of the shielding room, and it was kept at least 80 centimeters from any other grounded conducting surface.
2. Connect EUT to the power mains through a line impedance stabilization network (LISN).
3. All the support units are connecting to the other LISN.
4. The LISN provides 50 ohm coupling impedance for the measuring instrument.
5. The FCC states that a 50 ohm, 50 microhenry LISN should be used.
6. Both sides of AC line were checked for maximum conducted interference.
7. The frequency range from 150 kHz to 30 MHz was searched.
8. Set the test-receiver system to Peak Detect Function and specified bandwidth (IF Bandwidth = 9kHz) with Maximum Hold Mode. Then measurement is also conducted by Average Detector and Quasi-Peak Detector Function respectively.

### 3.1.4 Test setup

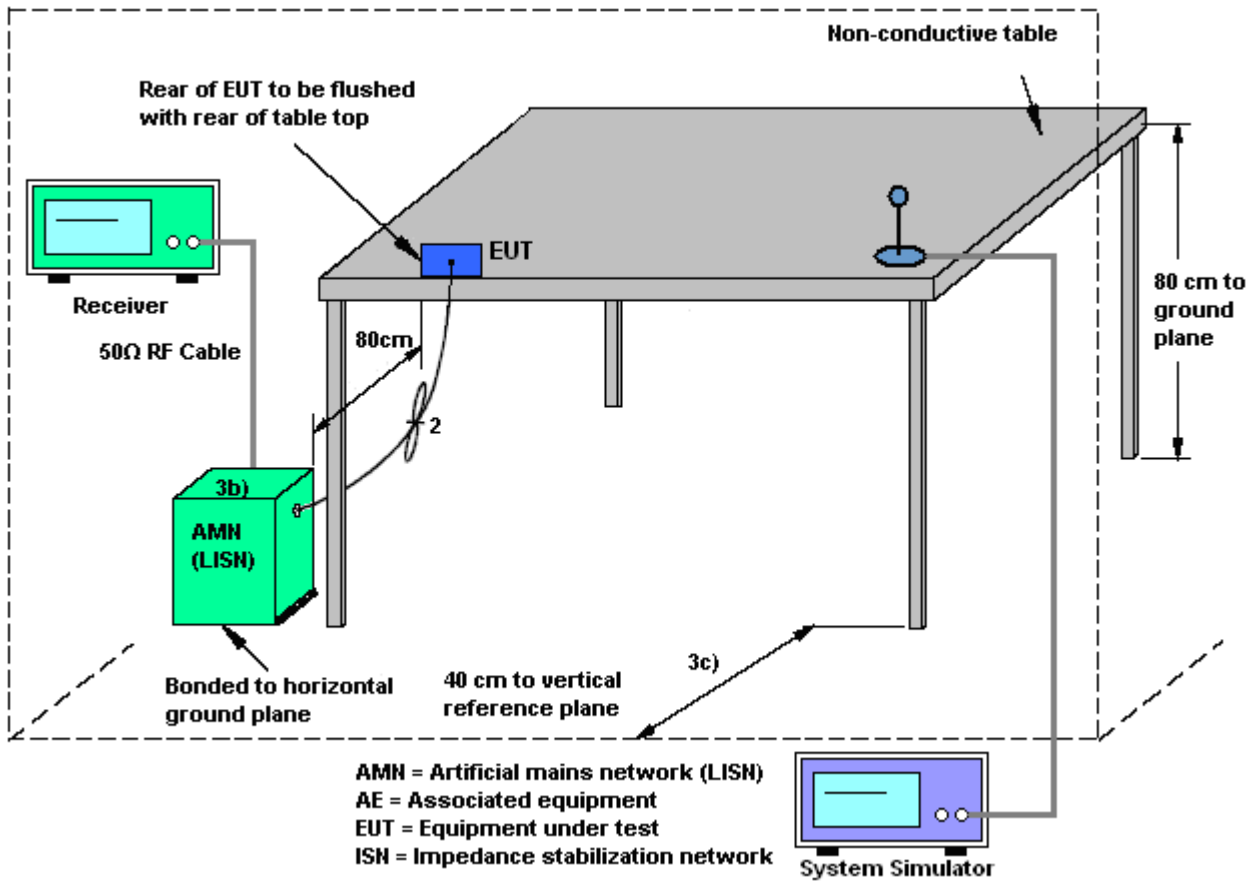

### 3.1.5 Test Result of AC Conducted Emission

Please refer to Appendix A.

## 3.2 20dB and 99% OBW Spectrum Bandwidth Measurement

### 3.2.1 Limit

Intentional radiators must be designed to ensure that the 20dB and 99% emission bandwidth in the specific band 13.553~13.567MHz.

### 3.2.2 Measuring Instruments

See list of measuring instruments of this test report.

### 3.2.3 Test Procedures

1. The spectrum analyzer connected via a receive antenna placed near the EUT in peak Max hold mode.
2. The resolution bandwidth of 1 kHz and the video bandwidth of 3 kHz were used.
3. Measured the spectrum width with power higher than 20dB below carrier.
4. Measured the 99% OBW.

### 3.2.4 Test Setup

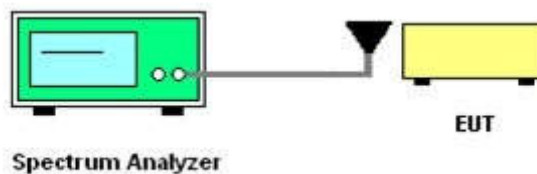

### 3.2.5 Test Result of Conducted Test Items

Please refer to Appendix B.

### 3.3 Frequency Stability Measurement

#### 3.3.1 Limit

The frequency tolerance of the carrier signal shall be maintained within +/- 0.01% (100ppm) of the operating frequency over a temperature variation of -20 degrees to +50 degrees C at normal supply voltage, and for a variation in the primary supply voltage from 85% to 115% of the rated supply voltage at a temperature of 20 degrees C. For battery operated equipment, the equipment tests shall be performed using a new battery.

#### 3.3.2 Measuring Instruments

See list of measuring instruments of this test report.

#### 3.3.3 Test Procedures

1. The spectrum analyzer connected via a receive antenna placed near the EUT.
2. EUT have transmitted signal and fixed channelize.
3. Set the spectrum analyzer span to view the entire emissions bandwidth.
4. Set RBW = 1 kHz, VBW = 3 kHz with peak detector and maxhold settings.
5. The  $f_c$  is declaring of channel frequency. Then the frequency error formula is  $(f_c - f) / f_c \times 10^6$  ppm and the limit is less than  $\pm 100$ ppm.
6. Extreme temperature rule is -20°C~50°C.

#### 3.3.4 Test Setup

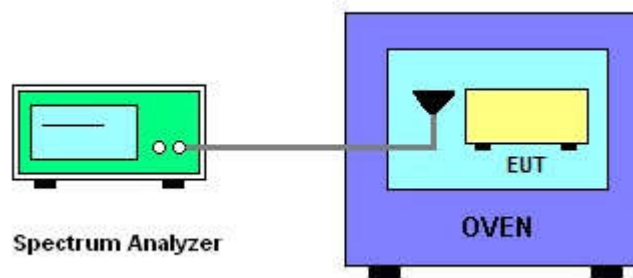

#### 3.3.5 Test Result of Conducted Test Items

Please refer to Appendix B.



### 3.4 Field Strength of Fundamental Emissions and Mask Measurement

#### 3.4.1 Limit

Rules and specifications	FCC CFR 47 Part 15 section 15.225			
Description	Compliance with the spectrum mask is tested with RBW set to 9kHz.			
Freq. of Emission (MHz)	Field Strength (μV/m) at 30m	Field Strength (dBμV/m) at 30m	Field Strength (dBμV/m) at 10m	Field Strength (dBμV/m) at 3m
1.705~13.110	30	29.5	48.58	69.5
13.110~13.410	106	40.5	59.58	80.5
13.410~13.553	334	50.5	69.58	90.5
13.553~13.567	15848	84.0	103.08	124.0
13.567~13.710	334	50.5	69.58	90.5
13.710~14.010	106	40.5	59.58	80.5
14.010~30.000	30	29.5	48.58	69.5

#### 3.4.2 Measuring Instruments

See list of measuring instruments of this test report.

#### 3.4.3 Test Procedures

1. Configure the EUT according to ANSI C63.10. The EUT was placed on the top of the turntable 0.8 meter above ground. The phase center of the loop receiving antenna mounted antenna tower was placed 3 meters far away from the turntable.
2. Power on the EUT and all the supporting units. The turntable was rotated by 360 degrees to determine the position of the highest radiation.
3. The height of the receiving antenna was fixed at one meter above ground to find the maximum emissions field strength.
4. For Fundamental emissions, use the receiver to measure QP reading.

5. When the radiated emissions limits are expressed in terms of the average value of the emissions, and pulsed operation is employed, the measurement field strength shall be determined by averaging over one complete pulse train, including blanking intervals, as long as the pulse train does not exceed 0.1 seconds. As an alternative (provided the transmitter operates for longer than 0.1 seconds) or in cases where the pulse train exceeds 0.1 seconds, the measured field strength shall be determined from the average absolute voltage during a 0.1 second interval during which the field strength is at its maximum value.
6. Compliance with the spectrum mask is tested with RBW set to 9kHz.  
Note: Emission level (dB $\mu$ V/m) = 20 log Emission level ( $\mu$ V/m).

### 3.4.4 Test Setup

For radiated emissions below 30MHz

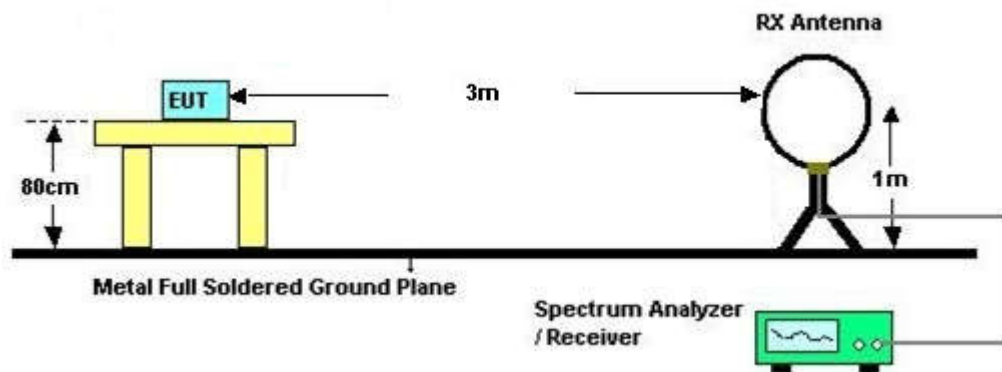

### 3.4.5 Test Result of Field Strength of Fundamental Emissions and Mask

Please refer to Appendix C.

### 3.5 Radiated Emissions Measurement

#### 3.5.1 Limit

The field strength of any emissions which appear outside of 13.110 ~14.010MHz band shall not exceed the general radiated emissions limits.

Frequencies (MHz)	Field Strength (µV/m)	Measurement Distance (meters)
0.009~0.490	2400/F(kHz)	300
0.490~1.705	24000/F(kHz)	30
1.705~30.0	30	30
30~88	100	3
88~216	150	3
216~960	200	3
Above 960	500	3

#### 3.5.2 Measuring Instruments

See list of measuring instruments of this test report.

#### 3.5.3 Measuring Instrument Setting

The following table is the setting of receiver.

Receiver Parameter	Setting
Attenuation	Auto
Frequency Range: 9kHz~150kHz	RBW 200Hz for QP
Frequency Range: 150kHz~30MHz	RBW 9kHz for QP
Frequency Range: 30MHz~1000MHz	RBW 120kHz for Peak

**Note:** The emission limits shown in the above table are based on measurements employing a CISPR quasi-peak detector except for the frequency bands 9-90 kHz, 110-490 kHz. Radiated emission limits in these two bands are based on measurements employing an average detector.



### **3.5.4 Test Procedures**

1. Configure the EUT according to ANSI C63.10. The EUT was placed on the top of the turntable 0.8 meter above ground. The phase center of the receiving antenna mounted on the top of a height-variable antenna tower was placed 3 meters far away from the turntable.
2. Power on the EUT and all the supporting units. The turntable was rotated by 360 degrees to determine the position of the highest radiation.
3. The height of the broadband receiving antenna was varied between one meter and four meters above ground to find the maximum emissions field strength of both horizontal and vertical polarization.
4. For each suspected emissions, the antenna tower was scan (from 1 M to 4 M) and then the turntable was rotated (from 0 degree to 360 degrees) to find the maximum reading.
5. Set the test-receiver system to Peak or CISPR quasi-peak Detect Function with specified bandwidth under Maximum Hold Mode.
6. When the radiated emissions limits are expressed in terms of the average value of the emissions, and pulsed operation is employed, the measurement field strength shall be determined by averaging over one complete pulse train, including blanking intervals, as long as the pulse train does not exceed 0.1 seconds. As an alternative (provided the transmitter operates for longer than 0.1 seconds) or in cases where the pulse train exceeds 0.1 seconds, the measured field strength shall be determined from the average absolute voltage during a 0.1 second interval during which the field strength is at its maximum value.
7. In case the emission is lower than 30MHz, loop antenna has to be used for measurement and the recorded data should be QP measured by receiver. Antenna Requirements

### 3.5.5 Test Setup

For radiated emissions above 30MHz

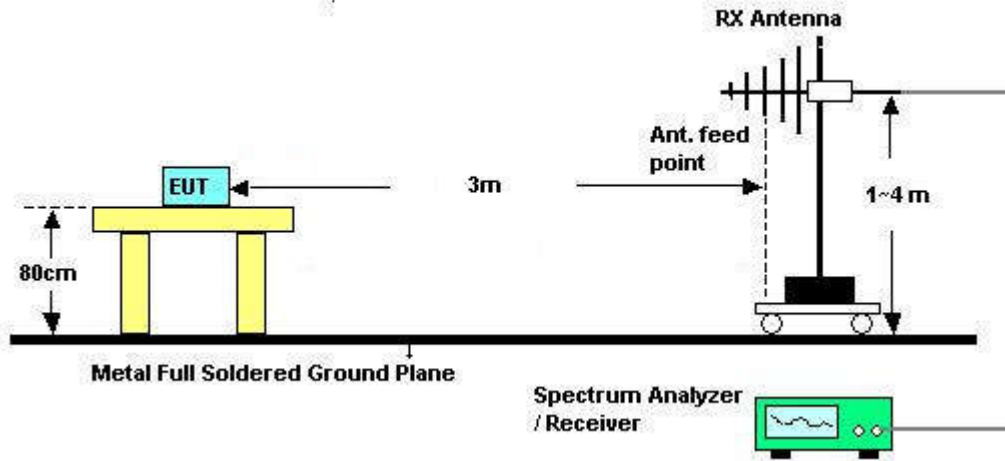

### 3.5.6 Test Result of Radiated Emissions Measurement

Please refer to Appendix C.



## **3.6 Antenna Requirements**

### **3.6.1 Standard Applicable**

Except for special regulations, the Low-power Radio-frequency Devices must not be equipped with any jacket for installing an antenna with extension cable. An intentional radiator shall be designed to ensure that no antenna other than that furnished by the responsible party shall be used with the device. The use of a permanently attached antenna or of an antenna that uses a unique coupling to the intentional radiator shall be considered sufficient to comply with the provisions of this Section. The manufacturer may design the unit so that the user can replace a broken antenna, but the use of a standard antenna jack or electrical connector is prohibited.

The use of a permanently attached antenna or of an antenna that uses a unique coupling to the intentional radiator shall be considered sufficient to comply with the FCC rule.

### **3.6.2 Antenna Anti-Replacement Construction**

An embedded-in antenna design is used.



### 4. LIST OF MEASURING EQUIPMENT

Instrument	Manufacturer	Model No.	Serial No.	Characteristics	Calibration Date	Test Date	Due Date	Remark
Spectrum Analyzer	R&S	FSV40	101040	10Hz~40GHz	Aug. 08, 2017	Jan. 05, 2018	Aug. 07, 2018	Conducted (TH01-KS)
Pulse Power Sensor	Anritsu	MA2411B	0917070	300MHz~40GHz	Jan. 19, 2017	Jan. 05, 2018	Jan. 19, 2018	Conducted (TH01-KS)
Power Meter	Anritsu	ML2495A	1005002	50MHz Bandwidth	Jan. 19, 2017	Jan. 05, 2018	Jan. 19, 2018	Conducted (TH01-KS)
EMI Test Receiver&SA	Agilent	N9038A	MY5226018 5	20Hz~26.5GHz	Apr. 20, 2017	Jan. 16, 2018	Apr.19, 2018	Radiation (03CH01-SZ)
Loop Antenna	R&S	HFH2-Z2	100354	9kHz~30MHz	May 14, 2017	Jan. 16, 2018	May 13, 2018	Radiation (03CH01- SZ)
Bilog Antenna	TeseQ	CBL6112D	23188	30MHz~2GHz	Apr. 25, 2017	Jan. 16, 2018	Apr. 24, 2018	Radiation (03CH01-SZ)
LF Amplifier	Burgeon	BPA-530	102209	0.01~3000Mhz	Apr. 20, 2017	Jan. 16, 2018	Apr. 19, 2018	Radiation (03CH01-SZ)
AC Power Source	Chroma	61601	6160100019 85	N/A	NCR	Jan. 16, 2018	NCR	Radiation (03CH01-SZ)
Turn Table	EM	EM1000	N/A	0~360 degree	NCR	Jan. 16, 2018	NCR	Radiation (03CH01-SZ)
Antenna Mast	EM	EM1000	N/A	1 m~4 m	NCR	Jan. 16, 2018	NCR	Radiation (03CH01-SZ)
EMI Receiver	R&S	ESC17	100768	9kHz~7GHz;	Apr. 20, 2017	Jan. 22, 2018	Apr. 19, 2018	Conduction (CO01-KS)
AC LISN	MessTec	AN3016	060103	9kHz~30MHz	Oct. 13, 2017	Jan. 22, 2018	Oct. 12, 2018	Conduction (CO01-KS)
AC LISN (for auxiliary equipment)	MessTec	AN3016	060105	9kHz~30MHz	Oct. 13, 2017	Jan. 22, 2018	Oct. 12, 2018	Conduction (CO01-KS)
AC Power Source	Chroma	61602	ABP000000 811	AC 0V~300V, 45Hz~1000Hz	Oct. 12, 2017	Jan. 22, 2018	Oct. 11, 2018	Conduction (CO01-KS)

NCR: No Calibration Required



## Appendix A. Test Results of Conducted Emission Test

Test Mode :	NFC Tx	Test Voltage :	120Vac / 60Hz
Function Type :	GSM850 Idle + Bluetooth Link + WLAN Link(2.4G) + USB Cable (Charging from Adapter 2) + Earphone + NFC Tx for Sample 1		

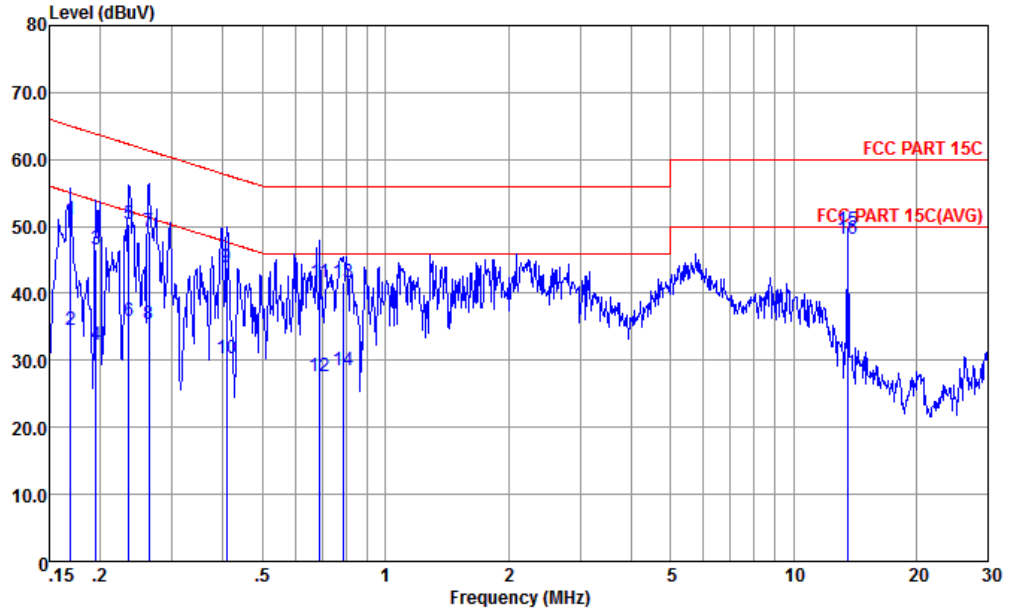

Site : CO01-KS  
 Condition : FCC PART 15C LISN-L-171013-060103 LINE

	Freq	Level	Over	Limit	Read	LISN	Cable	Remark
	MHz	dBuV	Limit	Line	Level	Factor	Loss	
			dB	dBuV	dBuV	dB	dB	
1	0.169	51.03	-13.96	64.99	40.30	0.18	10.55	QP
2	0.169	34.53	-20.46	54.99	23.80	0.18	10.55	Average
3	0.195	46.56	-17.24	63.80	35.89	0.20	10.47	QP
4	0.195	32.26	-21.54	53.80	21.59	0.20	10.47	Average
5	0.235	50.45	-11.81	62.26	39.80	0.21	10.44	QP
6	0.235	35.85	-16.41	52.26	25.20	0.21	10.44	Average
7	0.263	49.15	-12.19	61.34	38.49	0.22	10.44	QP
8	0.263	35.35	-15.99	51.34	24.69	0.22	10.44	Average
9	0.408	43.84	-13.84	57.68	33.19	0.25	10.40	QP
10	0.408	30.24	-17.44	47.68	19.59	0.25	10.40	Average
11	0.690	41.73	-14.27	56.00	31.30	0.26	10.17	QP
12	0.690	27.63	-18.37	46.00	17.20	0.26	10.17	Average
13	0.788	41.67	-14.33	56.00	31.30	0.26	10.11	QP
14	0.788	28.57	-17.43	46.00	18.20	0.26	10.11	Average
15	13.560	49.48	-10.52	60.00	38.81	0.28	10.39	QP
16 *	13.560	48.18	-1.82	50.00	37.51	0.28	10.39	Average

(1) with antenna

Remark: 13.560MHz is the NFC RF fundamental signal.



Test Mode :	NFC Tx	Test Voltage :	120Vac / 60Hz
Function Type :	GSM850 Idle + Bluetooth Link + WLAN Link(2.4G) + USB Cable (Charging from Adapter 2) + Earphone 1 + NFC Tx for Sample 1		

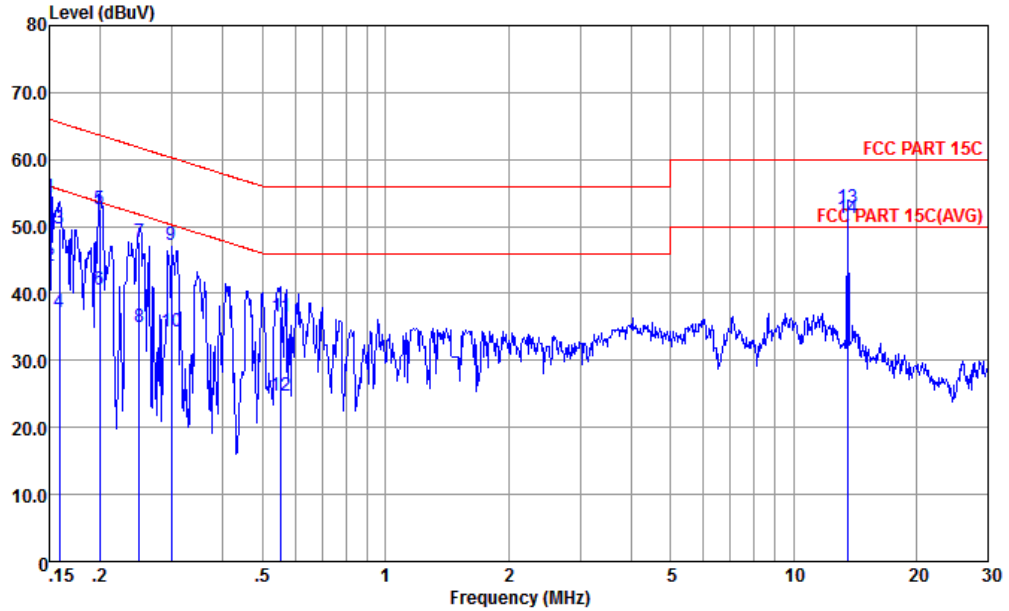

Site : CO01-KS  
 Condition : FCC PART 15C LISN-N-171013-060103 NEUTRAL

	Freq	Level	Over Limit	Limit Line	Read Level	LISN Factor	Cable Loss	Remark
	MHz	dBuV	dB	dBuV	dBuV	dB	dB	
1	0.150	54.40	-11.60	66.00	43.50	0.28	10.62	QP
2	0.150	44.10	-11.90	56.00	33.20	0.28	10.62	Average
3	0.159	49.77	-15.75	65.52	38.90	0.28	10.59	QP
4	0.159	37.17	-18.35	55.52	26.30	0.28	10.59	Average
5	0.200	52.64	-10.98	63.62	41.90	0.28	10.46	QP
6	0.200	40.54	-13.08	53.62	29.80	0.28	10.46	Average
7	0.249	47.62	-14.16	61.78	36.90	0.28	10.44	QP
8	0.249	34.92	-16.86	51.78	24.20	0.28	10.44	Average
9	0.299	47.21	-13.07	60.28	36.50	0.28	10.43	QP
10	0.299	34.41	-15.87	50.28	23.70	0.28	10.43	Average
11	0.555	36.45	-19.55	56.00	25.90	0.29	10.26	QP
12	0.555	24.75	-21.25	46.00	14.20	0.29	10.26	Average
13	13.560	52.72	-7.28	60.00	42.10	0.23	10.39	QP
14 *	13.560	51.22	1.22	50.00	40.60	0.23	10.39	Average

(1) with antenna

Remark: 13.560MHz is the NFC RF fundamental signal.



Test Mode :	NFC Tx	Test Voltage :	120Vac / 60Hz
Function Type :	GSM850 Idle + Bluetooth Link + WLAN Link(2.4G) + USB Cable (Charging from Adapter 2) + Earphone 1 + NFC Tx for Sample 1		

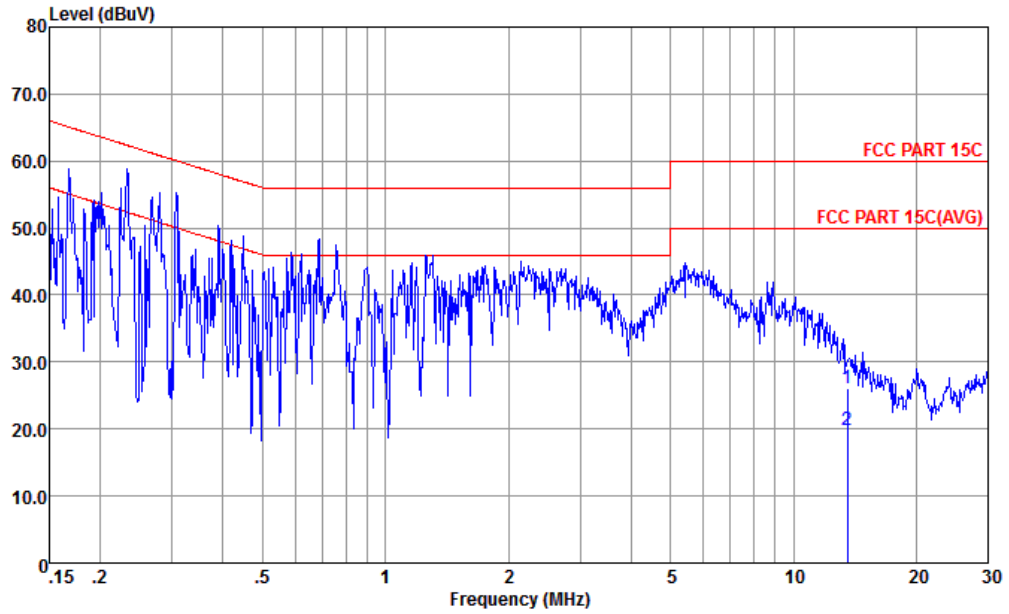

Site : CO01-KS  
 Condition : FCC PART 15C LISN-L-171013-060103 LINE

	Freq	Level	Over Limit	Limit Line	Read Level	LISN Factor	Cable Loss	Remark
	MHz	dBuV	dB	dBuV	dBuV	dB	dB	
1	13.560	26.18	-33.82	60.00	15.51	0.28	10.39	QP
2 *	13.560	19.88	-30.12	50.00	9.21	0.28	10.39	Average

(2) With dummy load

Remark: Only the fundamental NFC signal needs to be retested per C63.4.



Test Mode :	NFC Tx	Test Voltage :	120Vac / 60Hz
Function Type :	GSM850 Idle + Bluetooth Link + WLAN Link(2.4G) + USB Cable (Charging from Adapter 2) + Earphone 1 + NFC Tx for Sample 1		

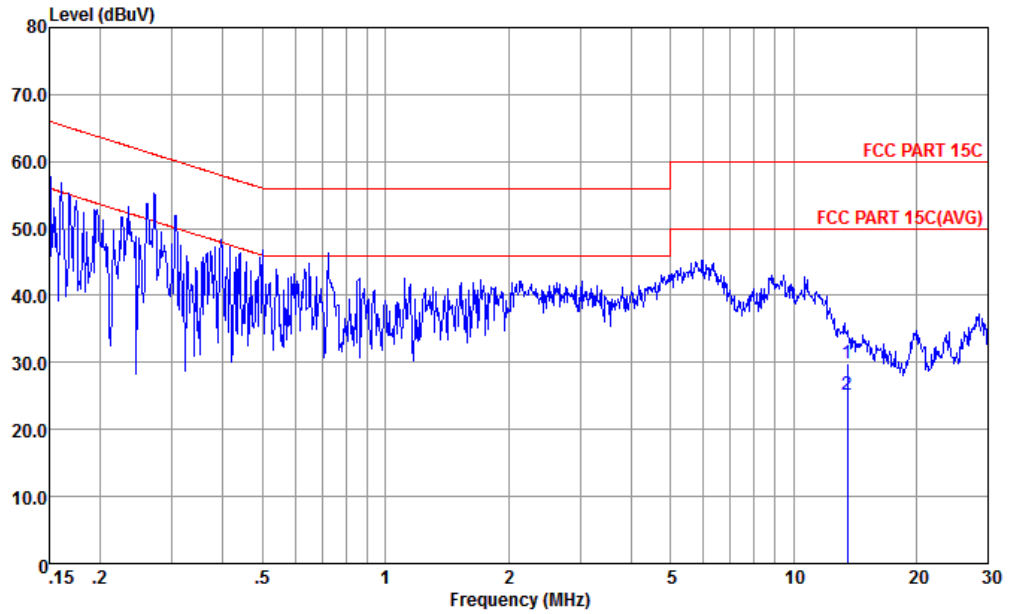

Site : CO01-KS  
 Condition : FCC PART 15C LISN-N-171013-060103 NEUTRAL

	Freq	Level	Over Limit	Limit Line	Read Level	LISN Factor	Cable Loss	Remark
	MHz	dBuV	dB	dBuV	dBuV	dB	dB	
1	13.560	29.83	-30.17	60.00	19.21	0.23	10.39	QP
2 *	13.560	25.23	-24.77	50.00	14.61	0.23	10.39	Average

(2) With dummy load

Remark: Only the fundamental NFC signal needs to be retested per C63.4.



## Appendix B. Test Results of Conducted Test Items

### B1. Test Result of 20dB Spectrum Bandwidth

Test mode	NFC Tx	Test Frequency (MHz)	13.56																																																								
<table border="1"> <thead> <tr> <th>Type</th> <th>Ref</th> <th>Trc</th> <th>X-value</th> <th>Y-value</th> <th>Function</th> <th>Function Result</th> </tr> </thead> <tbody> <tr> <td>M1</td> <td>1</td> <td></td> <td>13.560463 MHz</td> <td>-17.67 dBm</td> <td>ndB down</td> <td>2.489 kHz</td> </tr> <tr> <td>T1</td> <td>1</td> <td></td> <td>13.559219 MHz</td> <td>-37.93 dBm</td> <td>ndB</td> <td>20.00 dB</td> </tr> <tr> <td>T2</td> <td>1</td> <td></td> <td>13.561708 MHz</td> <td>-37.66 dBm</td> <td>Q factor</td> <td>5447.8</td> </tr> </tbody> </table>		Type	Ref	Trc	X-value	Y-value	Function	Function Result	M1	1		13.560463 MHz	-17.67 dBm	ndB down	2.489 kHz	T1	1		13.559219 MHz	-37.93 dBm	ndB	20.00 dB	T2	1		13.561708 MHz	-37.66 dBm	Q factor	5447.8	<table border="1"> <thead> <tr> <th>Type</th> <th>Ref</th> <th>Trc</th> <th>X-value</th> <th>Y-value</th> <th>Function</th> <th>Function Result</th> </tr> </thead> <tbody> <tr> <td>M1</td> <td>1</td> <td></td> <td>13.560521 MHz</td> <td>-17.09 dBm</td> <td></td> <td></td> </tr> <tr> <td>T1</td> <td>1</td> <td></td> <td>13.5594645 MHz</td> <td>-31.14 dBm</td> <td>Occ Bw</td> <td>2.112879884 kHz</td> </tr> <tr> <td>T2</td> <td>1</td> <td></td> <td>13.5615774 MHz</td> <td>-31.13 dBm</td> <td></td> <td></td> </tr> </tbody> </table>		Type	Ref	Trc	X-value	Y-value	Function	Function Result	M1	1		13.560521 MHz	-17.09 dBm			T1	1		13.5594645 MHz	-31.14 dBm	Occ Bw	2.112879884 kHz	T2	1		13.5615774 MHz	-31.13 dBm		
Type	Ref	Trc	X-value	Y-value	Function	Function Result																																																					
M1	1		13.560463 MHz	-17.67 dBm	ndB down	2.489 kHz																																																					
T1	1		13.559219 MHz	-37.93 dBm	ndB	20.00 dB																																																					
T2	1		13.561708 MHz	-37.66 dBm	Q factor	5447.8																																																					
Type	Ref	Trc	X-value	Y-value	Function	Function Result																																																					
M1	1		13.560521 MHz	-17.09 dBm																																																							
T1	1		13.5594645 MHz	-31.14 dBm	Occ Bw	2.112879884 kHz																																																					
T2	1		13.5615774 MHz	-31.13 dBm																																																							
<b>20dB Bandwidth (kHz)</b>	2.49	<b>99% OccupiedBW(kHz)</b>	2.11																																																								
<b>Frequency range (MHz)</b>	$f_L > 13.553$	13.559219	<b>Test Result</b>																																																								
	$f_H < 13.567$	13.561708	<b>Complies</b>																																																								

**Remark:** Because the measured signal is CW/CW-like adjusting the RBW per C63.10 would not be practical since measured bandwidth will always follow the RBW and the result will be approximately twice the RBW



B2. Test Result of Frequency Stability

Voltage vs. Frequency Stability		Temperature vs. Frequency Stability	
Voltage (Vac)	Measurement Frequency (MHz)	Temperature (°C)	Measurement Frequency (MHz)
120	13.560471	-20	13.560529
102	13.560471	-10	13.560529
138	13.560471	0	13.560529
		10	13.560464
		20	13.560464
		30	13.560464
		40	13.560464
		50	13.560464
<b>Max.Deviation (MHz)</b>	0.000471	<b>Max.Deviation (MHz)</b>	0.000528
<b>Max.Deviation (ppm)</b>	34.6976	<b>Max.Deviation (ppm)</b>	38.9749
<b>Limit</b>	<b>FS &lt; ±100 ppm</b>	<b>Limit</b>	<b>FS &lt; ±100 ppm</b>
<b>Test Result</b>	<b>PASS</b>	<b>Test Result</b>	<b>PASS</b>



# Appendix C. Test Results of Radiated Test Items

## C1. Test Result of Field Strength of Fundamental Emissions

Test Mode :	NFC Tx	Test Frequency (MHz)	13.56																																										
<p>Date: 2018-01-16</p> <p>Site : 03CH01-SZ Condition : 15.225 LIMIT 3m LOOP ANT 1706 HORIZONTAL</p> <table border="1"> <thead> <tr> <th>Over</th> <th>Limit</th> <th>ReadAntenna</th> <th>Cable</th> <th>A/Pos</th> <th>T/Pos</th> <th>Remark</th> </tr> <tr> <th>Level</th> <th>Line</th> <th>Level</th> <th>Loss</th> <th></th> <th></th> <th></th> </tr> <tr> <th>dB</th> <th>dBuV/m</th> <th>Factor</th> <th>dB</th> <th>cm</th> <th>deg</th> <th></th> </tr> <tr> <th>MHz</th> <th>dBuV/m</th> <th>dB</th> <th>dBuV/m</th> <th>dBuV</th> <th>dB/m</th> <th>dB</th> <th>cm</th> <th>deg</th> <th>Remark</th> </tr> </thead> <tbody> <tr> <td>1</td> <td>13.56</td> <td>53.98</td> <td>-70.02</td> <td>124.00</td> <td>34.06</td> <td>19.47</td> <td>0.45</td> <td>---</td> <td>---</td> <td>QP</td> </tr> </tbody> </table>				Over	Limit	ReadAntenna	Cable	A/Pos	T/Pos	Remark	Level	Line	Level	Loss				dB	dBuV/m	Factor	dB	cm	deg		MHz	dBuV/m	dB	dBuV/m	dBuV	dB/m	dB	cm	deg	Remark	1	13.56	53.98	-70.02	124.00	34.06	19.47	0.45	---	---	QP
Over	Limit	ReadAntenna	Cable	A/Pos	T/Pos	Remark																																							
Level	Line	Level	Loss																																										
dB	dBuV/m	Factor	dB	cm	deg																																								
MHz	dBuV/m	dB	dBuV/m	dBuV	dB/m	dB	cm	deg	Remark																																				
1	13.56	53.98	-70.02	124.00	34.06	19.47	0.45	---	---	QP																																			
<p>Date: 2018-01-16</p> <p>Site : 03CH01-SZ Condition : 15.225 LIMIT 3m LOOP ANT 1706 VERTICAL</p> <table border="1"> <thead> <tr> <th>Over</th> <th>Limit</th> <th>ReadAntenna</th> <th>Cable</th> <th>A/Pos</th> <th>T/Pos</th> <th>Remark</th> </tr> <tr> <th>Level</th> <th>Line</th> <th>Level</th> <th>Loss</th> <th></th> <th></th> <th></th> </tr> <tr> <th>dB</th> <th>dBuV/m</th> <th>Factor</th> <th>dB</th> <th>cm</th> <th>deg</th> <th></th> </tr> <tr> <th>MHz</th> <th>dBuV/m</th> <th>dB</th> <th>dBuV/m</th> <th>dBuV</th> <th>dB/m</th> <th>dB</th> <th>cm</th> <th>deg</th> <th>Remark</th> </tr> </thead> <tbody> <tr> <td>1</td> <td>13.56</td> <td>50.24</td> <td>-73.76</td> <td>124.00</td> <td>30.32</td> <td>19.47</td> <td>0.45</td> <td>---</td> <td>---</td> <td>QP</td> </tr> </tbody> </table>				Over	Limit	ReadAntenna	Cable	A/Pos	T/Pos	Remark	Level	Line	Level	Loss				dB	dBuV/m	Factor	dB	cm	deg		MHz	dBuV/m	dB	dBuV/m	dBuV	dB/m	dB	cm	deg	Remark	1	13.56	50.24	-73.76	124.00	30.32	19.47	0.45	---	---	QP
Over	Limit	ReadAntenna	Cable	A/Pos	T/Pos	Remark																																							
Level	Line	Level	Loss																																										
dB	dBuV/m	Factor	dB	cm	deg																																								
MHz	dBuV/m	dB	dBuV/m	dBuV	dB/m	dB	cm	deg	Remark																																				
1	13.56	50.24	-73.76	124.00	30.32	19.47	0.45	---	---	QP																																			



C2. Results of Radiated Spurious Emissions (9 kHz~30MHz)

Test Mode :	NFC Tx	Polarization :	Horizontal
-------------	--------	----------------	------------

Frequency ( MHz )	Level ( dBμV/m )	Over Limit ( dB )	Limit Line ( dBμV/m )	Read Level (dBμV)	Antenna Factor ( dB )	Cable Loss ( dB )	Ant Pos ( cm )	Table Pos ( deg )	Remark
0.01726	47.48	-75.38	122.86	26.43	21	0.05	-	-	Average
0.06939	49.67	-61.11	110.78	29.11	20.5	0.06	-	-	Average
0.09996	44.87	-62.74	107.61	24.1	20.7	0.07	-	-	QP
0.12627	61.78	-43.8	105.58	41.1	20.6	0.08	-	-	Average
1.647	37.42	-25.85	63.27	16.69	20.57	0.16	-	-	QP
2.084	36.01	-33.99	70	15.28	20.55	0.18	-	-	QP
13.824	33.08	-36.92	70	13.17	19.46	0.45	-	-	QP
24.937	32.49	-37.51	70	12.22	19.68	0.59	-	-	QP
29.865	36.46	-33.54	70	16.14	19.64	0.68	-	-	QP

Test Mode :	NFC Tx	Polarization :	Vertical
-------------	--------	----------------	----------

Frequency ( MHz )	Level ( dBμV/m )	Over Limit ( dB )	Limit Line ( dBμV/m )	Read Level (dBμV)	Antenna Factor ( dB )	Cable Loss ( dB )	Ant Pos ( cm )	Table Pos ( deg )	Remark
0.00925	51.11	-77.17	128.28	30.06	21	0.05	-	-	Average
0.06549	44.53	-66.75	111.28	23.97	20.5	0.06	-	-	Average
0.1023	40.43	-66.98	107.41	19.66	20.7	0.07	-	-	QP
0.13515	35.78	-69.21	104.99	15.1	20.6	0.08	-	-	Average
1.129	38.18	-28.37	66.55	17.46	20.59	0.13	-	-	QP
5.51	34.63	-35.37	70	14	20.35	0.28	-	-	QP
13.16	33.59	-36.41	70	13.66	19.49	0.44	-	-	QP
21.688	33.07	-36.93	70	13.25	19.27	0.55	-	-	QP
27.905	33.09	-36.91	70	13.04	19.41	0.64	-	-	QP

Note:

1. The amplitude of spurious emissions which are attenuated by more than 20dB below the permissible value has no need to be reported.
2. Distance extrapolation factor = 40 log (specific distance / test distance) (dB);
3. Limit line = specific limits (dBμV) + distance extrapolation factor.



C3. Results of Radiated Spurious Emissions (30MHz~1GHz)

Test Mode :	NFC Tx	Polarization :	Horizontal
-------------	--------	----------------	------------

Frequency ( MHz )	Level ( dBμV/m )	Over Limit ( dB )	Limit Line ( dBμV/m )	Read Level (dBμV)	Antenna Factor ( dB )	Cable Loss ( dB )	Preamp Factor ( dB )	Ant Pos ( cm )	Table Pos ( deg )	Remark
30.97	26.07	-13.93	40	30	27.42	0.25	31.6	-	-	Peak
230.79	32.59	-13.41	46	42.57	19.32	1.77	31.07	100	0	Peak
423.82	32.38	-13.62	46	35.44	25.56	2.48	31.1	-	-	Peak
649.83	29.59	-16.41	46	30.24	27.4	3.15	31.2	-	-	Peak
683.78	29.36	-16.64	46	29.73	27.6	3.23	31.2	-	-	Peak
952.47	31.49	-14.51	46	29.08	29.76	3.96	31.31	-	-	Peak

Test Mode :	NFC Tx	Polarization :	Vertical
-------------	--------	----------------	----------

Frequency ( MHz )	Level ( dBμV/m )	Over Limit ( dB )	Limit Line ( dBμV/m )	Read Level (dBμV)	Antenna Factor ( dB )	Cable Loss ( dB )	Preamp Factor ( dB )	Ant Pos ( cm )	Table Pos ( deg )	Remark
34.85	34.07	-5.93	40	39.05	26.3	0.32	31.6	-	-	Peak
40.67	36.94	-3.06	40	47.21	21.04	0.39	31.7	100	126	QP
230.79	29.89	-16.11	46	39.87	19.32	1.77	31.07	-	-	Peak
431.58	30.95	-15.05	46	33.65	25.9	2.5	31.1	-	-	Peak
651.77	31.31	-14.69	46	31.95	27.41	3.15	31.2	-	-	Peak
933.07	32.45	-13.55	46	30.58	29.27	3.9	31.3	-	-	Peak

Note:

1. The amplitude of spurious emissions which are attenuated by more than 20dB below the permissible value has no need to be reported.
2. Emission level (dBμV/m) = 20 log Emission level (μV/m).
3. Corrected Reading: Antenna Factor + Cable Loss + Read Level - Preamp Factor= Level.