



Test Report No.: W7L-P21110008RF17



VARIANT FCC TEST REPORT (PART 27)

Applicant:	Honeywell International Inc Honeywell Safety and Productivity Solutions
Address:	9680 Old Bailes Road, Fort Mill, SC 29707 United States

Manufacturer or Supplier:	Honeywell International Inc Honeywell Safety and Productivity Solutions
Address:	9680 Old Bailes Road, Fort Mill, SC 29707 United States
Product:	Mobile Computer
Brand Name:	Honeywell
Model Name:	CT45P-L1N-2
FCC ID:	HD5-CT45PL1N2
Date of tests:	Oct. 25, 2021 ~ Nov. 15, 2021

The tests have been carried out according to the requirements of the following standard:

- FCC Part 27, Subpart C, M ANSI/TIA/EIA-603-D
- FCC Part 2 ANSI/TIA/EIA-603-E ANSI C63.26-2015

CONCLUSION: The submitted sample was found to COMPLY with the test requirement

Prepared by Simon Wang Engineer / Mobile Department	Approved by Luke Lu Manager / Mobile Department
Date: Nov. 16, 2021	Date: Nov. 16, 2021
<small>This report is governed by, and incorporates by reference, CPS Conditions of Service as posted at the date of issuance of this report at http://www.bureauveritas.com/home/about-us/our-business/cps/about-us/terms-conditions and is intended for your exclusive use. Any copying or replication of this report to or for any other person or entity, or use of our name or trademark, is permitted only with our prior written permission. This report sets forth our findings solely with respect to the test samples identified herein. The results set forth in this report are not indicative or representative of the quality or characteristics of the lot from which a test sample was taken or any similar or identical product unless specifically and expressly noted. Our report includes all of the tests requested by you and the results thereof based upon the information that you provided to us. Measurement uncertainty is only provided upon request for accredited tests. You have 60 days from date of issuance of this report to notify us of any material error or omission caused by our negligence or if you require measurement uncertainty; provided, however, that such notice shall be in writing and shall specifically address the issue you wish to raise. A failure to raise such issue within the prescribed time shall constitute your unqualified acceptance of the completeness of this report, the tests conducted and the correctness of the report contents.</small>	



TABLE OF CONTENTS

RELEASE CONTROL RECORD	3
1 SUMMARY OF TEST RESULTS	4
1.1 MEASUREMENT UNCERTAINTY	5
1.2 TEST SITE AND INSTRUMENTS	6
2 GENERAL INFORMATION	7
2.1 GENERAL DESCRIPTION OF EUT	7
2.2 CONFIGURATION OF SYSTEM UNDER TEST	14
2.3 DESCRIPTION OF SUPPORT UNITS	15
2.4 TEST ITEM AND TEST CONFIGURATION	15
2.5 GENERAL DESCRIPTION OF APPLIED STANDARDS	24
3 TEST TYPES AND RESULTS	25
3.1 OUTPUT POWER MEASUREMENT	25
3.1.1 LIMITS OF OUTPUT POWER MEASUREMENT	25
3.1.2 TEST PROCEDURES	25
3.1.3 TEST SETUP	26
3.1.4 TEST RESULTS	27
3.2 FREQUENCY STABILITY MEASUREMENT	42
3.2.1 LIMITS OF FREQUENCY STABILITY MEASUREMENT	42
3.2.2 TEST PROCEDURE	42
3.2.3 TEST SETUP	42
3.2.4 TEST RESULTS	43
3.3 OCCUPIED BANDWIDTH MEASUREMENT	45
3.3.1 LIMITS OF OCCUPIED BANDWIDTH MEASUREMENT	45
3.3.2 TEST SETUP	45
3.3.3 TEST PROCEDURES	45
3.3.4 TEST RESULTS	46
3.4 BAND EDGE MEASUREMENT	56
3.4.1 LIMITS OF BAND EDGE MEASUREMENT	56
3.4.2 TEST SETUP	56
3.4.3 TEST PROCEDURES	57
3.4.4 TEST RESULTS	58
3.5 CONDUCTED SPURIOUS EMISSIONS	88
3.5.1 LIMITS OF CONDUCTED SPURIOUS EMISSIONS MEASUREMENT	88
3.5.2 TEST PROCEDURE	88
3.5.3 TEST SETUP	88
3.5.4 TEST RESULTS	89
3.6 RADIATED EMISSION MEASUREMENT	99
3.6.1 LIMITS OF RADIATED EMISSION MEASUREMENT	99
3.6.2 TEST PROCEDURES	99
3.6.3 DEVIATION FROM TEST STANDARD	99
3.6.4 TEST SETUP	100
3.6.5 TEST RESULTS	101
4 INFORMATION ON THE TESTING LABORATORIES	123
5 APPENDIX A – MODIFICATIONS RECORDERS FOR ENGINEERING CHANGES TO THE EUT BY THE LAB	124



Test Report No.: W7L-P21110008RF17

RELEASE CONTROL RECORD

ISSUE NO.	REASON FOR CHANGE	DATE ISSUED
W7L-P21080006RF17	Original release	Sep. 01, 2021
W7L-P21110008RF17	Based on the original report W7L-P21080006RF17 add the band 41C, changing components.	Nov. 16, 2021



Test Report No.: W7L-P21110008RF17

1 SUMMARY OF TEST RESULTS

The EUT has been tested according to the following specifications:

APPLIED STANDARD: FCC PART 27 & PART 2		
STANDARD SECTION	TEST TYPE AND LIMIT	RESULT
2.1046 27.50(h)(2)	Equivalent Isotropically Radiated Power	Compliance
2.1055 27.54	Frequency Stability	Compliance
2.1049 27.53(m)(6)	Occupied Bandwidth	Compliance
2.1051 27.53(m)(4)(6)	Band Edge Measurements	Compliance
2.1051 27.53(m)(4)(6)	Conducted Spurious Emissions	Compliance
2.1053 27.53(m)(4)(6)	Radiated Spurious Emissions	Compliance

Note:

1. Per the change notice provide by manufactory, the difference is changing components, SW and HW version, added band CA_41C by Software. Show CA 41C test data on this report. More test details please refer from the original report.

2. Pre-scan all band RSE, Part 27 worst case is band 13. Only band CA_41C is reflected in the report

1.1 MEASUREMENT UNCERTAINTY

Where relevant, the following measurement uncertainty levels have been estimated for tests performed on the EUT as specified in CISPR 16-4-2:

MEASUREMENT	UNCERTAINTY
Frequency Stability	$\pm 76.97\text{Hz}$
Radiated emissions & Radiated Power (30MHz~1GMHz)	$\pm 4.98\text{dB}$
Radiated emissions & Radiated Power (1GMHz ~6GMHz)	$\pm 4.70\text{dB}$
Radiated emissions (6GMHz ~18GMHz)	$\pm 4.60\text{dB}$
Radiated emissions (18GMHz ~40GMHz)	$\pm 4.12\text{dB}$
Conducted emissions	$\pm 4.01\text{dB}$
Occupied Channel Bandwidth	$\pm 43.58\text{KHz}$
Conducted Output power	$\pm 2.06\text{dB}$
Band Edge Measurements	$\pm 4.70\text{dB}$

This uncertainty represents an expanded uncertainty expressed at approximately the 95% confidence level using a coverage factor of $k=2$.

1.2 TEST SITE AND INSTRUMENTS

Equipment	Manufacturer	Model No.	Serial No.	Last Cal.	Next Cal.
MXE EMI Receiver	KEYSIGHT	N9038A-544	MY54450026	Apr. 22,21	Apr. 21,22
EXA Signal Analyzer	KEYSIGHT	N9010A-544	MY54510355	Jun. 03,21	Jun. 02,22
Bilog Antenna	ETS-LINDGREN	3143B	00161965	Mar. 05,21	Mar. 04,22
Horn Antenna	ETS-LINDGREN	3117	00168728	Apr. 02,21	Apr. 01,22
Horn Antenna (18GHz-40GHz)	N/A	QWH-SL-18-40-K-SG/QMS-00361	15433	Aug. 25, 21	Aug. 24, 22
Radio Communication Analyzer	ANRITSU	MT8820C	6201465426	Feb. 25,21	Feb. 24,22
Signal Pre-Amplifier	EMSI	EMC 9135	980249	Jun. 02,21	Jun. 01,22
Signal Pre-Amplifier	EMSI	EMC 012645B	980257	Jun. 03,21	Jun. 02,22
Signal Pre-Amplifier	EMSI	EMC 184045B	980259	Apr. 22,21	Apr. 21,22
3m Semi-anechoic Chamber	ETS-LINDGREN	9m*6m*6m	Euroshieldpn-CT0001143-1216	May. 19,20	May. 18,23
Test Software	E3	V 9.160323	N/A	N/A	N/A
Test Software	ADT	ADT_Radiated_V 7.6.15.9.2	N/A	N/A	N/A
10dB Attenuator	JFW/USA	50HF-010-SMA	1505	Jun. 03,21	Jun. 02,22
Power Meter	Anritsu	ML2495A	1506002	Apr. 07,21	Apr. 06,22
Power Sensor	Anritsu	MA2411B	1339352	May. 07,21	May. 06,22
Temperature Chamber	ESPEC	SH-242	93000855	Jun. 02,21	Jun. 01,22
MXG Analog Microwave Signal Generator	KEYSIGHT	N5183A	MY50143024	Mar. 05,21	Mar. 04,22
Power Divider	MCLI/USA	PS2-15	24880	N/A	N/A

- NOTE:**
1. The calibration interval of the above test instruments is 12 months or 36 months and the calibrations are traceable to CEPREI/CHINA, GRGT/CHINA and NIM/CHINA.
 2. The test was performed in 3m Semi-anechoic Chamber and RF Oven Room.
 3. The horn antenna is used only for the measurement of emission frequency above 1GHz if tested.
 4. The FCC Site Registration No. is 525120; The Designation No. is CN1171.

2 GENERAL INFORMATION

2.1 GENERAL DESCRIPTION OF EUT

PRODUCT	Mobile Computer	
BRAND NAME	Honeywell	
MODEL NAME	CT45P-L1N-2	
NOMINAL VOLTAGE	3.85Vdc (Lithium-ion cell, battery)	
MODULATION TECHNOLOGY	WCDMA IV	HSDPA, HSUPA, DC-HSDPA
	LTE	QPSK, 16QAM, 64QAM
FREQUENCY RANGE	WCDMA IV	1712.4MHz ~ 1752.6MHz
	LTE Band 7 Channel Bandwidth: 5MHz	2502.5MHz ~ 2567.5MHz
	LTE Band 7 Channel Bandwidth: 10MHz	2505MHz ~ 2565MHz
	LTE Band 7 Channel Bandwidth: 15MHz	2507.5MHz ~ 2562.5MHz
	LTE Band 7 Channel Bandwidth: 20MHz	2510MHz ~ 2560MHz
	LTE Band CA_7C Channel Bandwidth: 10MHz+20MHz	2505.5MHz ~ 2560MHz
	LTE Band CA_7C Channel Bandwidth: 15MHz+10MHz	2507.5MHz ~ 2564.7MHz
	LTE Band CA_7C Channel Bandwidth: 15MHz+15MHz	2507.5MHz ~ 2562.5MHz
	LTE Band CA_7C Channel Bandwidth: 15MHz+20MHz	2507.8MHz ~ 2560MHz
	LTE Band CA_7C Channel Bandwidth: 20MHz+10MHz	2510MHz ~ 2564.5MHz
	LTE Band CA_7C Channel Bandwidth: 20MHz+15MHz	2510MHz ~ 2562.5MHz
	LTE Band CA_7C Channel Bandwidth: 20MHz+20MHz	2510MHz ~ 2560MHz
	LTE Band 38 Channel Bandwidth: 5MHz	2572.5MHz ~ 2617.5MHz
	LTE Band 38 Channel Bandwidth: 10MHz	2575MHz ~ 2615MHz



**BUREAU
VERITAS**

Test Report No.: W7L-P21110008RF17

FREQUENCY RANGE	LTE Band 38 Channel Bandwidth: 15MHz	2577.5MHz ~ 2612.5MHz
	LTE Band 38 Channel Bandwidth: 20MHz	2580MHz ~ 2610MHz
	LTE Band 41 Channel Bandwidth: 5MHz	2498.5MHz ~ 2687.5MHz
	LTE Band 41 Channel Bandwidth: 10MHz	2501MHz ~ 2685MHz
	LTE Band 41 Channel Bandwidth: 15MHz	2503.5MHz ~ 2682.5MHz
	LTE Band 41 Channel Bandwidth: 20MHz	2506MHz ~ 2680MHz
	LTE Band CA_41C Channel Bandwidth: 5MHz+20MHz	2499.3MHz ~ 2668.3MHz
	LTE Band CA_41C Channel Bandwidth: 10MHz+15MHz	2501.3MHz ~ 2670.5MHz
	LTE Band CA_41C Channel Bandwidth: 10MHz+20MHz	2501.5MHz ~ 2665.6MHz
	LTE Band CA_41C Channel Bandwidth: 15MHz+10MHz	2503.5MHz ~ 2672.7MHz
	LTE Band CA_41C Channel Bandwidth: 15MHz+15MHz	2503.5MHz ~ 2667.5MHz
	LTE Band CA_41C Channel Bandwidth: 15MHz+20MHz	2503.8MHz ~ 2662.9MHz
	LTE Band CA_41C Channel Bandwidth: 20MHz+5MHz	2506.0MHz ~ 2675.0MHz
	LTE Band CA_41C Channel Bandwidth: 20MHz+10MHz	2506.0MHz ~ 2670.1MHz
	LTE Band CA_41C Channel Bandwidth: 20MHz+15MHz	2506.0MHz ~ 2665.1MHz
	LTE Band CA_41C Channel Bandwidth: 20MHz+20MHz	2506.0MHz ~ 2660.2MHz
	EMISSION DESIGNATOR	WCDMA IV
LTE Band 7 Channel Bandwidth: 5MHz		QPSK: 4M49G7D
		16QAM: 4M48W7D
		64QAM: 4M49W7D
LTE Band 7 Channel Bandwidth: 10MHz		QPSK:9M01G7D
		16QAM: 8M97W7D
	64QAM: 8M99W7D	

EMISSION DESIGNATOR	LTE Band 7 Channel Bandwidth: 15MHz	QPSK: 13M6G7D
		16QAM: 13M5W7D
		64QAM: 13M5W7D
	LTE Band 7 Channel Bandwidth: 20MHz	QPSK: 18M0G7D
		16QAM: 18M0W7D
		64QAM: 18M0W7D
	LTE Band CA_7C Channel Bandwidth: 10MHz+20MHz	QPSK: 28M2G7D
		16QAM: 28M1W7D
		64QAM: 28M0W7D
	LTE Band CA_7C Channel Bandwidth: 15MHz +10MHz	QPSK: 23M6G7D
		16QAM: 23M6W7D
		64QAM: 23M6W7D
	LTE Band CA_7C Channel Bandwidth: 15MHz +15MHz	QPSK: 28M7G7D
		16QAM: 28M7W7D
		64QAM: 28M7W7D
	LTE Band CA_7C Channel Bandwidth: 15MHz +20MHz	QPSK: 32M9G7D
		16QAM: 32M9W7D
		64QAM: 32M8W7D
	LTE Band CA_7C Channel Bandwidth: 20MHz +10MHz	QPSK: 28M1G7D
		16QAM: 28M0W7D
		64QAM: 28M0W7D
	LTE Band CA_7C Channel Bandwidth: 20MHz +15MHz	QPSK: 32M8G7D
		16QAM: 32M8W7D
		64QAM: 32M8W7D
	LTE Band CA_7C Channel Bandwidth: 20MHz +20MHz	QPSK: 37M6G7D
		16QAM: 37M6W7D
		64QAM: 37M6W7D
LTE Band 38 Channel Bandwidth: 5MHz	QPSK: 4M48G7D	
	16QAM: 4M47W7D	
	64QAM: 4M47W7D	
LTE Band 38 Channel Bandwidth: 10MHz	QPSK: 8M97G7D	
	16QAM: 8M96W7D	
	64QAM: 8M96W7D	
LTE Band 38 Channel Bandwidth: 15MHz	QPSK: 13M4G7D	
	16QAM: 13M5W7D	
	64QAM: 13M5W7D	
LTE Band 38 Channel Bandwidth: 20MHz	QPSK: 17M9G7D	
	64QAM: 17M9W7D	
	16QAM: 17M9W7D	
LTE Band 41 Channel Bandwidth: 5MHz	QPSK: 4M48G7D	
	16QAM: 4M48W7D	
	64QAM: 4M47W7D	

EMISSION DESIGNATOR	LTE Band 41 Channel Bandwidth: 10MHz	QPSK: 8M97G7D
		16QAM: 8M96W7D
		64QAM: 8M96W7D
	LTE Band 41 Channel Bandwidth: 15MHz	QPSK: 13M5G7D
		16QAM: 13M5W7D
		64QAM: 13M4W7D
	LTE Band 41 Channel Bandwidth: 20MHz	QPSK: 17M9G7D
		16QAM: 17M9W7D
		64QAM: 17M9W7D
	LTE Band CA_41C Channel Bandwidth: 5MHz+20MHz	QPSK: 23M4G7D
		16QAM: 23M3W7D
		64QAM: 23M2W7D
	LTE Band CA_41C Channel Bandwidth: 10MHz+15MHz	QPSK: 23M5G7D
		16QAM: 23M7W7D
		64QAM: 23M6W7D
	LTE Band CA_41C Channel Bandwidth: 10MHz+20MHz	QPSK: 28M2G7D
		16QAM: 28M1W7D
		64QAM: 28M2W7D
	LTE Band CA_41C Channel Bandwidth: 15MHz +10MHz	QPSK: 23M7G7D
		16QAM: 23M7W7D
		64QAM: 23M7W7D
	LTE Band CA_41C Channel Bandwidth: 15MHz +15MHz	QPSK: 28M8G7D
		16QAM: 28M7W7D
		64QAM: 28M7W7D
	LTE Band CA_41C Channel Bandwidth: 15MHz +20MHz	QPSK: 32M8G7D
		16QAM: 32M8W7D
		64QAM: 32M7W7D
	LTE Band CA_41C Channel Bandwidth: 20MHz +5MHz	QPSK: 23M4G7D
		16QAM: 23M3W7D
		64QAM: 23M4W7D
LTE Band CA_41C Channel Bandwidth: 20MHz +10MHz	QPSK: 28M1G7D	
	16QAM: 28M3W7D	
	64QAM: 28M2W7D	
LTE Band CA_41C Channel Bandwidth: 20MHz +15MHz	QPSK: 32M9G7D	
	16QAM: 32M9W7D	
	64QAM: 32M8W7D	
LTE Band CA_41C Channel Bandwidth: 20MHz +20MHz	QPSK: 37M7G7D	
	16QAM: 37M6W7D	
	64QAM: 37M6W7D	



**BUREAU
VERITAS**

Test Report No.: W7L-P21110008RF17

MAX. EIRP POWER	WCDMA IV	148.94mW
	LTE Band 7 Channel Bandwidth: 5MHz	229.09mW
	LTE Band 7 Channel Bandwidth: 10MHz	230.67mW
	LTE Band 7 Channel Bandwidth: 15MHz	230.67mW
	LTE Band 7 Channel Bandwidth: 20MHz	232.81mW
	LTE Band CA_7C Channel Bandwidth: 10MHz+20MHz	230.14mW
	LTE Band CA_7C Channel Bandwidth: 15MHz+10MHz	225.4mW
	LTE Band CA_7C Channel Bandwidth: 15MHz+15MHz	221.82mW
	LTE Band CA_7C Channel Bandwidth: 15MHz+20MHz	221.31mW
	LTE Band CA_7C Channel Bandwidth: 20MHz+10MHz	221.82mW
	LTE Band CA_7C Channel Bandwidth: 20MHz+15MHz	224.91mW
	LTE Band CA_7C Channel Bandwidth: 20MHz+20MHz	232.27mW
	LTE Band 38 Channel Bandwidth: 5MHz	219.79mW
	LTE Band 38 Channel Bandwidth: 10MHz	220.29mW
	LTE Band 38 Channel Bandwidth: 15MHz	221.82mW
	LTE Band 38 Channel Bandwidth: 20MHz	222.33mW
	LTE Band 41 Channel Bandwidth: 5MHz	261.82mW
	LTE Band 41 Channel Bandwidth: 10MHz	261.82mW
	LTE Band 41 Channel Bandwidth: 15MHz	263.03mW
	LTE Band 41 Channel Bandwidth: 20MHz	264.85mW



BUREAU
VERITAS

Test Report No.: W7L-P21110008RF17

MAX. EIRP POWER	LTE Band CA_41C Channel Bandwidth: 5MHz+20MHz	250.61mW
	LTE Band CA_41C Channel Bandwidth: 20MHz+5MHz	251.19mW
	LTE Band CA_41C Channel Bandwidth: 10MHz+15MHz	250.03mW
	LTE Band CA_41C Channel Bandwidth: 15MHz+10MHz	250.61mW
	LTE Band CA_41C Channel Bandwidth: 15MHz+15MHz	251.77mW
	LTE Band CA_41C Channel Bandwidth: 10MHz+20MHz	252.93mW
	LTE Band CA_41C Channel Bandwidth: 20MHz+10MHz	253.51mW
	LTE Band CA_41C Channel Bandwidth: 15MHz+20MHz	251.77mW
	LTE Band CA_41C Channel Bandwidth: 20MHz+15MHz	252.93mW
	LTE Band CA_41C Channel Bandwidth: 20MHz+20MHz	260.02mW
ANTENNA TYPE	PIFA Antenna with 2.55 dBi gain for WCDMA IV PIFA Antenna with 2.02 dBi gain for LTE7/ LTE7C PIFA Antenna with 1.73 dBi gain for LTE38 PIFA Antenna with 2.02 dBi gain for LTE41 PIFA Antenna with 2.02 dBi gain for LTE41C	
HW VERSION	V1.0	
SW VERSION	OS.11.002-HON.11.002	
I/O PORTS	Refer to user's manual	
CABLE SUPPLIED	USB cable: unshielded without ferrite, 1.25 meter Earphone cable: unshielded without ferrite, 1.27 meter	
EXTREME TEMPERATURE	-10-55 °C	
EXTREME VOLTAGE	3.4V- 4.4V	



**BUREAU
VERITAS**

Test Report No.: W7L-P21110008RF17

NOTE:

1. For a more detailed features description, please refer to the manufacturer’s specifications or the user's manual.
2. This product includes the following three SKU which hardware is exactly same, the difference is described as following, Sample 1 was full test, sample 2 verify the worst case,check worst case Radiated emission:

SAMPLE	EUT CONFIGURATION INFORMATION
1	SKU ID:CT45-L1N-37D120G ,Assembled Scanner Imager: 7-S0703
2	SKU ID:CT45-L1N-38D120G ,Assembled Scanner Imager: 8 - N6803/S0803
3	SKU ID: CT45-L1N-37D220G , Assembled with Scanner: 7-S0703 for China Only with Android non-GMS

3. For the test results, the EUT had been tested with all conditions. But only the worst case was shown in test report.

List of Accessory:

ACCESSORIES	BRAND	MODEL	SPECIFICATION
Battery	Honeywell	CT50-BTSC	Capacity : 3.85vdc 4020mAh
AC Adapter	HONOR	ADS-12B-06 05010E	I/P:100-240Vac, 0.3A O/P: 5Vdc, 2A
USB Cable	Honeywell	CT40-SN	Shielded, 1.25meter
Earphone	VIVO	N/A	Shielded, 1.27meter
LCD Panel	CASIL	CTM10801920T01	5.0" FHD(1928*1080)

2.2 CONFIGURATION OF SYSTEM UNDER TEST

FOR RADIATION EMISSION TEST

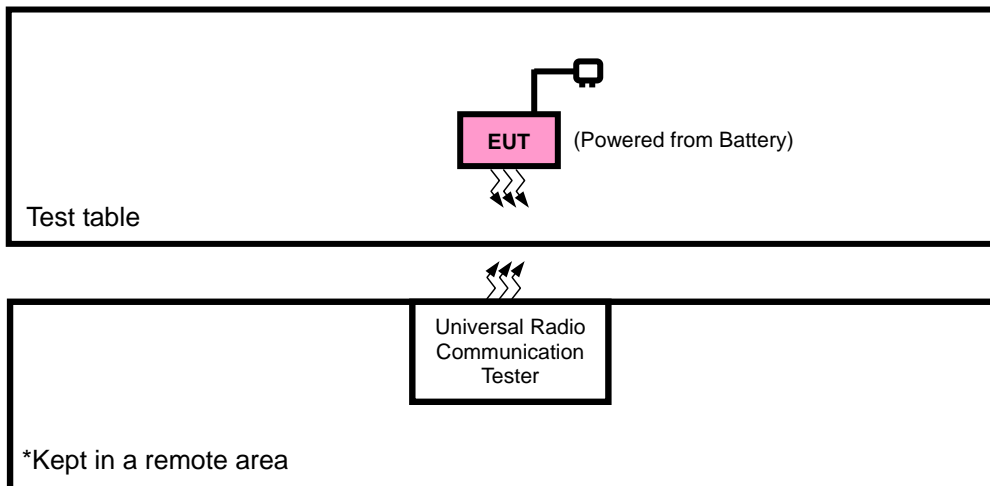



2.3 DESCRIPTION OF SUPPORT UNITS

The EUT has been tested as an independent unit together with other necessary accessories or support units. The following support units or accessories were used to form a representative test configuration during the tests.

NO.	PRODUCT	BRAND	MODEL NO.	SERIAL NO.	FCC ID
1	DC source	LONG WEI	PS-6403D	010934269	N/A

NO.	SIGNAL CABLE DESCRIPTION OF THE ABOVE SUPPORT UNITS
1	DC Line: Unshielded, Detachable 1.8m

2.4 TEST ITEM AND TEST CONFIGURATION

Pre-Scan has been conducted to determine the worst-case mode from all possible combinations between available modulations, data rates, XYZ axis and antenna ports. The worst case was found when positioned on Y-plane for EIRP and X-axis for radiated emission. Following channel(s) was (were) selected for the final test as listed below:

EUT CONFIGURE MODE	DESCRIPTION
B	EUT + Battery with LTE link



**BUREAU
VERITAS**

Test Report No.: W7L-P21110008RF17

LTE BAND CA_41C MODE

TEST ITEM	AVAILABLE CHANNEL	TESTED CHANNEL	CHANNEL BANDWIDTH	MODULATION	MODE
TRANSMITTER OUTPUT POWER	39750 to 41341 39921 to 41512	39750 (2506MHz)+ 39921 (2523.1MHz), 40546 (2585.6MHz)+ 40717 (2602.7MHz) 41341 (2665.1MHz)+ 41512 (2682.2MHz),	20+15MHz	QPSK, 16QAM, 64QAM	1 RB / 99 RB Offset + 1 RB / 0 RB Offset
	39728 to 41319 39899 to 41490	39728 (2503.8MHz)+ 39899 (2520.9MHz), 40523 (2583.3MHz)+ 40694 (2600.4MHz) 41319 (2662.9MHz)+ 41490 (2680MHz),	15+20MHz	QPSK, 16QAM, 64QAM	1 RB / 74 RB Offset + 1 RB / 0 RB Offset
	39750 to 41391 39894 to 41535	39750 (2506MHz)+ 39894 (2520.4MHz), 40571 (2588.1MHz)+ 40715 (2602.5MHz) 41391 (2670.1MHz)+ 41535 (2684.5MHz),	20+10MHz	QPSK, 16QAM, 64QAM	1 RB / 99 RB Offset + 1 RB / 0 RB Offset N
	39705 to 41346 39849 to 41490	39705 (2501.5MHz)+ 39849 (2515.9MHz), 40526 (2583.6MHz)+ 40670 (2598.0MHz) 41346 (2665.6MHz)+ 41490 (2680MHz),	10+20MHz	QPSK, 16QAM, 64QAM	1 RB / 49 RB Offset + 1 RB / 0 RB Offset
	39725 to 41365 39875 to 41515	39725 (2503.5MHz)+ 39875 (2518.5MHz), 40545 (2585.5MHz)+ 40695 (2600.5MHz) 41365 (2667.5MHz)+ 41515 (2682.5MHz),	15+15MHz	QPSK, 16QAM, 64QAM	1 RB / 74 RB Offset + 1 RB / 0 RB Offset
	39725 to 41417 39845 to 41537	39725 (2503.5MHz)+ 39845 (2515.5MHz), 40571 (2588.1MHz)+ 40691 (2600.1MHz) 41417 (2672.7MHz)+ 41537 (2684.7MHz),	15+10MHz	QPSK, 16QAM, 64QAM	1 RB / 74 RB Offset + 1 RB / 0 RB Offset



**BUREAU
VERITAS**

Test Report No.: W7L-P21110008RF17

TRANSMITTER OUTPUT POWER	39703 to 41395 39823 to 41515	39703 (2501.3MHz)+ 39823 (2513.3MHz), 40549 (2585.9MHz)+ 40669 (2597.9MHz) 41395 (2670.5MHz)+ 41515 (2682.5MHz),	10+15MHz	QPSK, 16QAM, 64QAM	1 RB / 49 RB Offset + 1 RB / 0 RB Offset
	39750 to 41440 39867 to 41557	39750 (2506MHz)+ 39867 (2517.7MHz), 40595 (2590.5MHz)+ 40712 (2602.2MHz) 41440 (2675MHz)+ 41557 (2686.7MHz),	20+5MHz	QPSK, 16QAM, 64QAM	1 RB / 99 RB Offset + 1 RB / 0 RB Offset
	39683 to 41373 39800 to 41490	39683 (2499.3MHz)+ 39800 (2511MHz), 40528 (2583.8MHz)+ 40645 (2595.5MHz) 41373 (2668.3MHz)+ 41490 (2680MHz),	5+20MHz	QPSK, 16QAM, 64QAM	1 RB / 24 RB Offset + 1 RB / 0 RB Offset
	39750 to 41292 39948 to 41490	39750 (2506MHz)+ 39948 (2525.8MHz), 40521 (2583.1MHz)+ 40719 (2602.9MHz) 41292 (2660.2MHz)+ 41490 (2680MHz),	20+20MHz	QPSK, 16QAM, 64QAM	1 RB / 99 RB Offset , 1 RB / 0 RB Offset + 0 RB / 0 RB Offset , 1 RB / 99 RB Offset + 1 RB / 0 RB Offset ,
OCCUPIED BANDWIDTH	39750 to 41341 39921 to 41512	39750 (2506MHz)+ 39921 (2523.1MHz), 40546 (2585.6MHz)+ 40717 (2602.7MHz) 41341 (2665.1MHz)+ 41512 (2682.2MHz),	20+15MHz	QPSK, 16QAM, 64QAM	100 RB / 0 RB Offset + 75 RB / 0 RB Offset
	39728 to 41319 39899 to 41490	39728 (2503.8MHz)+ 39899 (2520.9MHz), 40523 (2583.3MHz)+ 40694 (2600.4MHz) 41319 (2662.9MHz)+ 41490 (2680MHz),	15+20MHz	QPSK, 16QAM, 64QAM	75 RB / 0 RB Offset + 100 RB / 0 RB Offset



**BUREAU
VERITAS**

Test Report No.: W7L-P21110008RF17

OCCUPIED BANDWIDTH	39750 to 41391 39894 to 41535	39750 (2506MHz)+ 39894 (2520.4MHz), 40571 (2588.1MHz)+ 40715 (2602.5MHz) 41391 (2670.1MHz)+ 41535 (2684.5MHz),	20+10MHz	QPSK, 16QAM, 64QAM	100 RB / 0 RB Offset + 50 RB / 0 RB Offset
	39705 to 41346 39849 to 41490	39705 (2501.5MHz)+ 39849 (2515.9MHz), 40526 (2583.6MHz)+ 40670 (2598.0MHz) 41346 (2665.6MHz)+ 41490 (2680MHz),	10+20MHz	QPSK, 16QAM, 64QAM	50 RB / 0 RB Offset + 100 RB / 0 RB Offset
	39725 to 41365 39875 to 41515	39725 (2503.5MHz)+ 39875 (2518.5MHz), 40545 (2585.5MHz)+ 40695 (2600.5MHz) 41365 (2667.5MHz)+ 41515 (2682.5MHz),	15+15MHz	QPSK, 16QAM, 64QAM	75 RB / 0 RB Offset + 75 RB / 0 RB Offset
	39725 to 41417 39845 to 41537	39725 (2503.5MHz)+ 39845 (2515.5MHz), 40571 (2588.1MHz)+ 40691 (2600.1MHz) 41417 (2672.7MHz)+ 41537 (2684.7MHz),	15+10MHz	QPSK, 16QAM, 64QAM	75 RB / 0 RB Offset + 50 RB / 0 RB Offset
	39703 to 41395 39823 to 41515	39703 (2501.3MHz)+ 39823 (2513.3MHz), 40549 (2585.9MHz)+ 40669 (2597.9MHz) 41395 (2670.5MHz)+ 41515 (2682.5MHz),	10+15MHz	QPSK, 16QAM, 64QAM	50 RB / 0 RB Offset + 75 RB / 0 RB Offset
	39750 to 41440 39867 to 41557	39750 (2506MHz)+ 39867 (2517.7MHz), 40595 (2590.5MHz)+ 40712 (2602.2MHz) 41440 (2675MHz)+ 41557 (2686.7MHz),	20+5MHz	QPSK, 16QAM, 64QAM	100 RB / 0 RB Offset + 25 RB / 0 RB Offset



**BUREAU
VERITAS**

Test Report No.: W7L-P21110008RF17

OCCUPIED BANDWIDTH	39683 to 41373 39800 to 41490	39683 (2499.3MHz)+ 39800 (2511MHz), 40528 (2583.8MHz)+ 40645 (2595.5MHz) 41373 (2668.3MHz)+ 41490 (2680MHz),	5+20MHz	QPSK, 16QAM, 64QAM	25 RB / 0 RB Offset + 100 RB / 0 RB Offset
	39750 to 41292 39948 to 41490	39750 (2506MHz)+ 39948 (2525.8MHz), 40521 (2583.1MHz)+ 40719 (2602.9MHz) 41292 (2660.2MHz)+ 41490 (2680MHz),	20+20MHz	QPSK, 16QAM, 64QAM	100 RB / 0 RB Offset + 100 RB / 0 RB Offset
TRANSMITTER UNWANTED EMISSIONS	39750 to 41341 39921 to 41512	39750 (2506MHz)+ 39921 (2523.1MHz), 40546 (2585.6MHz)+ 40717 (2602.7MHz) 41341 (2665.1MHz)+ 41512 (2682.2MHz),	20+15MHz	QPSK, 16QAM, 64QAM	1 RB / 99 RB Offset + 1 RB / 0 RB Offset
	39728 to 41319 39899 to 41490	39728 (2503.8MHz)+ 39899 (2520.9MHz), 40523 (2583.3MHz)+ 40694 (2600.4MHz) 41319 (2662.9MHz)+ 41490 (2680MHz),	15+20MHz	QPSK, 16QAM, 64QAM	1 RB / 74 RB Offset + 1 RB / 0 RB Offset
	39750 to 41391 39894 to 41535	39750 (2506MHz)+ 39894 (2520.4MHz), 40571 (2588.1MHz)+ 40715 (2602.5MHz) 41391 (2670.1MHz)+ 41535 (2684.5MHz),	20+10MHz	QPSK, 16QAM, 64QAM	1 RB / 99 RB Offset + 1 RB / 0 RB Offset
	39705 to 41346 39849 to 41490	39705 (2501.5MHz)+ 39849 (2515.9MHz), 40526 (2583.6MHz)+ 40670 (2598.0MHz) 41346 (2665.6MHz)+ 41490 (2680MHz),	10+20MHz	QPSK, 16QAM, 64QAM	1 RB / 49 RB Offset + 1 RB / 0 RB Offset
	39725 to 41365 39875 to 41515	39725 (2503.5MHz)+ 39875 (2518.5MHz), 40545 (2585.5MHz)+ 40695 (2600.5MHz) 41365 (2667.5MHz)+ 41515 (2682.5MHz),	15+15MHz	QPSK, 16QAM, 64QAM	1 RB / 74 RB Offset + 1 RB / 0 RB Offset

TRANSMITTER UNWANTED EMISSIONS	39725 to 41417 39845 to 41537	39725 (2503.5MHz)+ 39845 (2515.5MHz), 40571 (2588.1MHz)+ 40691 (2600.1MHz) 41417 (2672.7MHz)+ 41537 (2684.7MHz),	15+10MHz	QPSK, 16QAM, 64QAM	1 RB / 74 RB Offset + 1 RB / 0 RB Offset
	39703 to 41395 39823 to 41515	39703 (2501.3MHz)+ 39823 (2513.3MHz), 40549 (2585.9MHz)+ 40669 (2597.9MHz) 41395 (2670.5MHz)+ 41515 (2682.5MHz),	10+15MHz	QPSK, 16QAM, 64QAM	1 RB / 49 RB Offset + 1 RB / 0 RB Offset
	39750 to 41440 39867 to 41557	39750 (2506MHz)+ 39867 (2517.7MHz), 40595 (2590.5MHz)+ 40712 (2602.2MHz) 41440 (2675MHz)+ 41557 (2686.7MHz),	20+5MHz	QPSK, 16QAM, 64QAM	1 RB / 99 RB Offset + 1 RB / 0 RB Offset
	39683 to 41373 39800 to 41490	39683 (2499.3MHz)+ 39800 (2511MHz), 40528 (2583.8MHz)+ 40645 (2595.5MHz) 41373 (2668.3MHz)+ 41490 (2680MHz),	5+20MHz	QPSK, 16QAM, 64QAM	1 RB / 24 RB Offset + 1 RB / 0 RB Offset
	39750 to 41292 39948 to 41490	39750 (2506MHz)+ 39948 (2525.8MHz), 40521 (2583.1MHz)+ 40719 (2602.9MHz) 41292 (2660.2MHz)+ 41490 (2680MHz),	20+20MHz	QPSK, 16QAM, 64QAM	1 RB / 99 RB Offset + 1 RB / 0 RB Offset
FREQUENCY PLAN	39750 to 41341 39921 to 41512	39750 (2506MHz)+ 39921 (2523.1MHz), 40546 (2585.6MHz)+ 40717 (2602.7MHz) 41341 (2665.1MHz)+ 41512 (2682.2MHz),	20+15MHz	QPSK, 16QAM, 64QAM	1 RB / 99 RB Offset + 1 RB / 0 RB Offset



**BUREAU
VERITAS**

Test Report No.: W7L-P21110008RF17

FREQUENCY PLAN	39728 to 41319 39899 to 41490	39728 (2503.8MHz)+ 39899 (2520.9MHz), 40523 (2583.3MHz)+ 40694 (2600.4MHz) 41319 (2662.9MHz)+ 41490 (2680MHz),	15+20MHz	QPSK, 16QAM, 64QAM	1 RB / 74 RB Offset + 1 RB / 0 RB Offset
	39750 to 41391 39894 to 41535	39750 (2506MHz)+ 39894 (2520.4MHz), 40571 (2588.1MHz)+ 40715 (2602.5MHz) 41391 (2670.1MHz)+ 41535 (2684.5MHz),	20+10MHz	QPSK, 16QAM, 64QAM	1 RB / 99 RB Offset + 1 RB / 0 RB Offset
	39705 to 41346 39849 to 41490	39705 (2501.5MHz)+ 39849 (2515.9MHz), 40526 (2583.6MHz)+ 40670 (2598.0MHz) 41346 (2665.6MHz)+ 41490 (2680MHz),	10+20MHz	QPSK, 16QAM, 64QAM	1 RB / 49 RB Offset + 1 RB / 0 RB Offset
	39725 to 41365 39875 to 41515	39725 (2503.5MHz)+ 39875 (2518.5MHz), 40545 (2585.5MHz)+ 40695 (2600.5MHz) 41365 (2667.5MHz)+ 41515 (2682.5MHz),	15+15MHz	QPSK, 16QAM, 64QAM	1 RB / 74 RB Offset + 1 RB / 0 RB Offset
	39725 to 41417 39845 to 41537	39725 (2503.5MHz)+ 39845 (2515.5MHz), 40571 (2588.1MHz)+ 40691 (2600.1MHz) 41417 (2672.7MHz)+ 41537 (2684.7MHz),	15+10MHz	QPSK, 16QAM, 64QAM	1 RB / 74 RB Offset + 1 RB / 0 RB Offset
	39703 to 41395 39823 to 41515	39703 (2501.3MHz)+ 39823 (2513.3MHz), 40549 (2585.9MHz)+ 40669 (2597.9MHz) 41395 (2670.5MHz)+ 41515 (2682.5MHz),	10+15MHz	QPSK, 16QAM, 64QAM	1 RB / 49 RB Offset + 1 RB / 0 RB Offset



**BUREAU
VERITAS**

Test Report No.: W7L-P21110008RF17

	39750 to 41440 39867 to 41557	39750 (2506MHz)+ 39867 (2517.7MHz), 40595 (2590.5MHz)+ 40712 (2602.2MHz) 41440 (2675MHz)+ 41557 (2686.7MHz),	20+5MHz	QPSK, 16QAM, 64QAM	1 RB / 99 RB Offset + 1 RB / 0 RB Offset
	39683 to 41373 39800 to 41490	39683 (2499.3MHz)+ 39800 (2511MHz), 40528 (2583.8MHz)+ 40645 (2595.5MHz) 41373 (2668.3MHz)+ 41490 (2680MHz),	5+20MHz	QPSK, 16QAM, 64QAM	1 RB / 24 RB Offset + 1 RB / 0 RB Offset
	39750 to 41292 39948 to 41490	39750 (2506MHz)+ 39948 (2525.8MHz), 40521 (2583.1MHz)+ 40719 (2602.9MHz) 41292 (2660.2MHz)+ 41490 (2680MHz),	20+20MHz	QPSK, 16QAM, 64QAM	1 RB / 99 RB Offset + 1 RB / 0 RB Offset
PEAK TO AVERAGE RATIO	/	/	/	QPSK, 16QAM, 64QAM	/
TYPE OF MODULATION	/	/	/	QPSK, 16QAM, 64QAM	/

Note: This device was tested under all bandwidths, RB configurations and modulations. The worst case was found in QPSK modulation.



Test Report No.: W7L-P21110008RF17

TEST CONDITION:

TEST ITEM	ENVIRONMENTAL CONDITIONS	INPUT POWER	TESTED BY
ERP	23deg. C, 70%RH	DC 3.85V By Battery	Jace Hu
FREQUENCY STABILITY	23deg. C, 70%RH	DC 3.85V By Battery	Chase Zhou
OCCUPIED BANDWIDTH	23deg. C, 70%RH	DC 3.85V By Battery	Chase Zhou
BAND EDGE	23deg. C, 70%RH	DC 3.85V By Battery	Chase Zhou
CONDCUDED EMISSION	23deg. C, 70%RH	DC 3.85V By Battery	Chase Zhou
RADIATED EMISSION	23deg. C, 70%RH	DC 3.85V By Battery	Jace Hu



Test Report No.: W7L-P21110008RF17

2.5 GENERAL DESCRIPTION OF APPLIED STANDARDS

The EUT is a RF product. According to the specifications of the manufacturer, it must comply with the requirements of the following standards:

FCC 47 CFR Part 2

FCC 47 CFR Part 27

KDB 971168 D01 Power Meas License Digital Systems v03r01

ANSI/TIA/EIA-603-D

ANSI/TIA/EIA-603-E

ANSI C63.26-2015

NOTE: All test items have been performed and recorded as per the above standards.



3 TEST TYPES AND RESULTS

3.1 OUTPUT POWER MEASUREMENT

3.1.1 LIMITS OF OUTPUT POWER MEASUREMENT

The radiated peak output power shall be according to the specific rule Part 27.50(h)(2) that “User stations are limited to 2 watts” and 27.50(i) specific that “Peak transmit power must be measure over any interval of continuous transmission using instrumentation calibration in terms of rms-equivalent voltage.”

Fixed, mobile, and portable (hand-held) stations operating in the 1710-1755 MHz band and mobile and portable stations operating in the 1695-1710 MHz and 1755-1780 MHz bands are limited to 1 watt EIRP

3.1.2 TEST PROCEDURES

EIRP MEASUREMENT:

Per KDB 971168 D01 Power Meas License Digital Systems v03r01 or subclause 5.2.5.5 of ANSI C63.26-2015, the relevant equation for determining the ERP or EIRP from the conducted RF output power measured using the guidance provided above is:

$$\text{ERP or EIRP} = P_{\text{Meas}} + G_{\text{T}} - L_{\text{C}}$$

Where:

ERP or EIRP = effective radiated power or equivalent isotropically radiated power, respectively

(expressed in the same units as P_{Meas} , typically dBW or dBm);

P_{Meas} = measured transmitter output power or PSD, in dBm or dBW;

G_{T} = gain of the transmitting antenna, in dBd (ERP) or dBi (EIRP);

L_{C} = signal attenuation in the connecting cable between the transmitter and antenna, in dB.

CONDUCTED POWER MEASUREMENT:

- a. The EUT was set up for the maximum power with LTE link data modulation and link up with simulator.
- b. Set the EUT to transmit under low, middle and high channel and record the power level shown on simulator.



Test Report No.: W7L-P21110008RF17

3.1.3 TEST SETUP

CONDUCTED POWER MEASUREMENT:

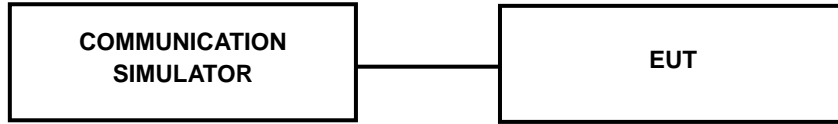

For the actual test configuration, please refer to the attached file (Test Setup Photo).

3.1.4 TEST RESULTS

LTE Band CA_41C

CA_41C								
Combination 5MHz+20MHz (25RB+100RB)								
PCC	SCC	Modulation	PCC		SCC		Total RB Size	Measured Power (dBm)
Channel	Channel		RB Size	RB offset	RB Size	RB offset		
39683	39800	QPSK	1	0	0	0	1	21.97
		16QAM	1	0	0	0	1	20.76
		64QAM	1	0	0	0	1	19.99
40528	40645	QPSK	1	0	0	0	1	21.19
		16QAM	1	0	0	0	1	20.35
		64QAM	1	0	0	0	1	19.50
41373	41490	QPSK	1	0	0	0	1	20.68
		16QAM	1	0	0	0	1	19.78
		64QAM	1	0	0	0	1	19.06
Combination 10MHz+15MHz (50RB+75RB)								
PCC	SCC	Modulation	PCC		SCC		Total RB Size	Measured Power (dBm)
Channel	Channel		RB Size	RB offset	RB Size	RB offset		
39703	39823	QPSK	1	0	0	0	1	21.96
		16QAM	1	0	0	0	1	20.83
		64QAM	1	0	0	0	1	20.06
40549	40669	QPSK	1	0	0	0	1	21.26
		16QAM	1	0	0	0	1	20.42
		64QAM	1	0	0	0	1	19.55
41395	41515	QPSK	1	0	0	0	1	20.73
		16QAM	1	0	0	0	1	19.81
		64QAM	1	0	0	0	1	19.12

CA_41C								
Combination 10MHz+20MHz (50RB+100RB)								
PCC	SCC	Modulation	PCC		SCC		Total RB Size	Measured Power (dBm)
Channel	Channel		RB Size	RB offset	RB Size	RB offset		
39705	39849	QPSK	1	0	0	0	1	22.01
		16QAM	1	0	0	0	1	20.93
		64QAM	1	0	0	0	1	20.14
40526	40670	QPSK	1	0	0	0	1	21.36
		16QAM	1	0	0	0	1	20.51
		64QAM	1	0	0	0	1	19.64
41346	41490	QPSK	1	0	0	0	1	20.83
		16QAM	1	0	0	0	1	19.87
		64QAM	1	0	0	0	1	19.20
Combination 15MHz+10MHz (75RB+50RB)								
PCC	SCC	Modulation	PCC		SCC		Total RB Size	Measured Power (dBm)
Channel	Channel		RB Size	RB offset	RB Size	RB offset		
39725	39845	QPSK	1	0	0	0	1	21.97
		16QAM	1	0	0	0	1	20.86
		64QAM	1	0	0	0	1	20.08
40571	40691	QPSK	1	0	0	0	1	21.30
		16QAM	1	0	0	0	1	20.47
		64QAM	1	0	0	0	1	19.58
41417	41537	QPSK	1	0	0	0	1	20.75
		16QAM	1	0	0	0	1	19.83
		64QAM	1	0	0	0	1	19.15

CA_41C								
Combination 15MHz+15MHz (75RB+75RB)								
PCC	SCC	Modulation	PCC		SCC		Total RB Size	Measured Power (dBm)
Channel	Channel		RB Size	RB offset	RB Size	RB offset		
39725	39875	QPSK	1	0	0	0	1	21.99
		16QAM	1	0	0	0	1	20.89
		64QAM	1	0	0	0	1	20.09
40545	40695	QPSK	1	0	0	0	1	21.33
		16QAM	1	0	0	0	1	20.49
		64QAM	1	0	0	0	1	19.62
41365	41515	QPSK	1	0	0	0	1	20.80
		16QAM	1	0	0	0	1	19.86
		64QAM	1	0	0	0	1	19.17
Combination 15MHz+20MHz (75RB+100RB)								
PCC	SCC	Modulation	PCC		SCC		Total RB Size	Measured Power (dBm)
Channel	Channel		RB Size	RB offset	RB Size	RB offset		
39728	39899	QPSK	1	0	0	0	1	21.99
		16QAM	1	0	0	0	1	20.95
		64QAM	1	0	0	0	1	20.13
40523	40694	QPSK	1	0	0	0	1	21.38
		16QAM	1	0	0	0	1	20.52
		64QAM	1	0	0	0	1	19.62
41319	41490	QPSK	1	0	0	0	1	20.82
		16QAM	1	0	0	0	1	19.87
		64QAM	1	0	0	0	1	19.21



BUREAU
VERITAS

Test Report No.: W7L-P21110008RF17

CA_41C								
Combination 20MHz+10MHz (100RB+50RB)								
PCC	SCC	Modulation	PCC		SCC		Total RB Size	Measured Power (dBm)
Channel	Channel		RB Size	RB offset	RB Size	RB offset		
39750	39894	QPSK	1	0	0	0	1	22.02
		16QAM	1	0	0	0	1	20.96
		64QAM	1	0	0	0	1	20.16
40571	40715	QPSK	1	0	0	0	1	21.40
		16QAM	1	0	0	0	1	20.56
		64QAM	1	0	0	0	1	19.67
41391	41535	QPSK	1	0	0	0	1	20.85
		16QAM	1	0	0	0	1	19.89
		64QAM	1	0	0	0	1	19.23
Combination 20MHz+15MHz (100RB+75RB)								
PCC	SCC	Modulation	PCC		SCC		Total RB Size	Measured Power (dBm)
Channel	Channel		RB Size	RB offset	RB Size	RB offset		
39750	39921	QPSK	1	0	0	0	1	22.01
		16QAM	1	0	0	0	1	20.98
		64QAM	1	0	0	0	1	20.14
40546	40717	QPSK	1	0	0	0	1	21.41
		16QAM	1	0	0	0	1	20.54
		64QAM	1	0	0	0	1	19.66
41341	41512	QPSK	1	0	0	0	1	20.87
		16QAM	1	0	0	0	1	19.90
		64QAM	1	0	0	0	1	19.23

CA_41C								
Combination 20MHz+20MHz (100RB+100RB)								
PCC Channel	SCC Channel	Modulation	PCC		SCC		Total RB Size	Measured Power (dBm)
			RB Size	RB offset	RB Size	RB offset		
39750	39948	QPSK	1	0	1	99	2	10.13
			1	0	0	0	1	22.13
			1	99	1	0	2	19.42
		16QAM	1	0	1	99	2	10.34
			1	0	0	0	1	21.23
			1	99	1	0	2	18.85
		64QAM	1	0	1	99	2	10.25
			1	0	0	0	1	20.08
			1	99	1	0	2	18.24
40521	40719	QPSK	1	0	1	99	2	10.56
			1	0	0	0	1	22.03
			1	99	1	0	2	18.91
		16QAM	1	0	1	99	2	10.26
			1	0	0	0	1	20.93
			1	99	1	0	2	17.82
		64QAM	1	0	1	99	2	10.02
			1	0	0	0	1	20.05
			1	99	1	0	2	16.95
41292	41490	QPSK	1	0	1	99	2	9.74
			1	0	0	0	1	21.38
			1	99	1	0	2	18.17
		16QAM	1	0	1	99	2	9.56
			1	0	0	0	1	20.61
			1	99	1	0	2	17.28
		64QAM	1	0	1	99	2	9.28
			1	0	0	0	1	19.83
			1	99	1	0	2	16.41



BUREAU
VERITAS

Test Report No.: W7L-P21110008RF17

EIRP
LTE BAND CA_41C

LTE BAND CA_41C 5M+20M QPSK								
Channel	Frequency (MHz)	Channel	Frequency (MHz)	Conducted Power (dBm)	Gain (dB)	EIRP (dBm)	EIRP (mW)	Lmit (W)
39683	2499.3	39800	2511	21.97	2.02	23.99	250.61	2
40528	2583.8	40645	2595.5	21.19	2.02	23.21	209.41	2
41373	2668.3	41490	2680	20.68	2.02	22.7	186.21	2
LTE BAND CA_41C 5M+20M 16QAM								
Channel	Frequency (MHz)	Channel	Frequency (MHz)	Conducted Power (dBm)	Gain (dB)	EIRP (dBm)	EIRP (mW)	Lmit (W)
39683	2499.3	39800	2511	20.76	2.02	22.78	189.67	2
40528	2583.8	40645	2595.5	20.35	2.02	22.37	172.58	2
41373	2668.3	41490	2680	19.78	2.02	21.8	151.36	2
LTE BAND CA_41C 5M+20M 64QAM								
Channel	Frequency (MHz)	Channel	Frequency (MHz)	Conducted Power (dBm)	Gain (dB)	EIRP (dBm)	EIRP (mW)	Lmit (W)
39683	2499.3	39800	2511	19.99	2.02	22.01	158.85	2
40528	2583.8	40645	2595.5	19.5	2.02	21.52	141.91	2
41373	2668.3	41490	2680	19.06	2.02	21.08	128.23	2



Test Report No.: W7L-P21110008RF17

LTE BAND CA_41C 20M+5M QPSK								
Channel	Frequency (MHz)	Channel	Frequency (MHz)	Conducted Power (dBm)	Gain (dB)	EIRP (dBm)	EIRP (mW)	Lmit (W)
39750	2506	39867	2517.7	21.98	2.02	24	251.19	2
40595	2590.5	40712	2602.2	21.23	2.02	23.25	211.35	2
41440	2675	41557	2686.7	20.7	2.02	22.72	187.07	2
LTE BAND CA_41C 20M+5M 16QAM								
Channel	Frequency (MHz)	Channel	Frequency (MHz)	Conducted Power (dBm)	Gain (dB)	EIRP (dBm)	EIRP (mW)	Lmit (W)
39750	2506	39867	2517.7	20.79	2.02	22.81	190.99	2
40595	2590.5	40712	2602.2	20.4	2.02	22.42	174.58	2
41440	2675	41557	2686.7	19.8	2.02	21.82	152.05	2
LTE BAND CA_41C 20M+5M 64QAM								
Channel	Frequency (MHz)	Channel	Frequency (MHz)	Conducted Power (dBm)	Gain (dB)	EIRP (dBm)	EIRP (mW)	Lmit (W)
39750	2506	39867	2517.7	20.01	2.02	22.03	159.59	2
40595	2590.5	40712	2602.2	19.53	2.02	21.55	142.89	2
41440	2675	41557	2686.7	19.09	2.02	21.11	129.12	2



Test Report No.: W7L-P21110008RF17

LTE BAND CA_41C 10M+15M QPSK								
Channel	Frequency (MHz)	Channel	Frequency (MHz)	Conducted Power (dBm)	Gain (dB)	EIRP (dBm)	EIRP (mW)	Lmit (W)
39703	2501.3	39823	2513.3	21.96	2.02	23.98	250.03	2
40549	2585.9	40669	2597.9	21.26	2.02	23.28	212.81	2
41395	2670.5	41515	2682.5	20.73	2.02	22.75	188.36	2
LTE BAND CA_41C 10M+15M 16QAM								
Channel	Frequency (MHz)	Channel	Frequency (MHz)	Conducted Power (dBm)	Gain (dB)	EIRP (dBm)	EIRP (mW)	Lmit (W)
39703	2501.3	39823	2513.3	20.83	2.02	22.85	192.75	2
40549	2585.9	40669	2597.9	20.42	2.02	22.44	175.39	2
41395	2670.5	41515	2682.5	19.81	2.02	21.83	152.41	2
LTE BAND CA_41C 10M+15M 64QAM								
Channel	Frequency (MHz)	Channel	Frequency (MHz)	Conducted Power (dBm)	Gain (dB)	EIRP (dBm)	EIRP (mW)	Lmit (W)
39703	2501.3	39823	2513.3	20.06	2.02	22.08	161.44	2
40549	2585.9	40669	2597.9	19.55	2.02	21.57	143.55	2
41395	2670.5	41515	2682.5	19.12	2.02	21.14	130.02	2



Test Report No.: W7L-P21110008RF17

LTE BAND CA_41C 15M+10M QPSK								
Channel	Frequency (MHz)	Channel	Frequency (MHz)	Conducted Power (dBm)	Gain (dB)	EIRP (dBm)	EIRP (mW)	Lmit (W)
39725	2503.5	39845	2515.5	21.97	2.02	23.99	250.61	2
40571	2588.1	40691	2600.1	21.3	2.02	23.32	214.78	2
41417	2672.7	41537	2684.7	20.75	2.02	22.77	189.23	2
LTE BAND CA_41C 15M+10M 16QAM								
Channel	Frequency (MHz)	Channel	Frequency (MHz)	Conducted Power (dBm)	Gain (dB)	EIRP (dBm)	EIRP (mW)	Lmit (W)
39725	2503.5	39845	2515.5	20.86	2.02	22.88	194.09	2
40571	2588.1	40691	2600.1	20.47	2.02	22.49	177.42	2
41417	2672.7	41537	2684.7	19.83	2.02	21.85	153.11	2
LTE BAND CA_41C 15M+10M 64QAM								
Channel	Frequency (MHz)	Channel	Frequency (MHz)	Conducted Power (dBm)	Gain (dB)	EIRP (dBm)	EIRP (mW)	Lmit (W)
39725	2503.5	39845	2515.5	20.08	2.02	22.1	162.18	2
40571	2588.1	40691	2600.1	19.58	2.02	21.6	144.54	2
41417	2672.7	41537	2684.7	19.15	2.02	21.17	130.92	2



Test Report No.: W7L-P21110008RF17

LTE BAND CA_41C 15M+15M QPSK								
Channel	Frequency (MHz)	Channel	Frequency (MHz)	Conducted Power (dBm)	Gain (dB)	EIRP (dBm)	EIRP (mW)	Lmit (W)
39725	2496	39875	2511	21.99	2.02	24.01	251.77	2
40545	2585.5	40695	2600.5	21.33	2.02	23.35	216.27	2
41365	2667.5	41515	2682.5	20.8	2.02	22.82	191.43	2
LTE BAND CA_41C 15M+15M 16QAM								
Channel	Frequency (MHz)	Channel	Frequency (MHz)	Conducted Power (dBm)	Gain (dB)	EIRP (dBm)	EIRP (mW)	Lmit (W)
39725	2496	39875	2511	20.89	2.02	22.91	195.43	2
40545	2585.5	40695	2600.5	20.49	2.02	22.51	178.24	2
41365	2667.5	41515	2682.5	19.86	2.02	21.88	154.17	2
LTE BAND CA_41C 15M+15M 64QAM								
Channel	Frequency (MHz)	Channel	Frequency (MHz)	Conducted Power (dBm)	Gain (dB)	EIRP (dBm)	EIRP (mW)	Lmit (W)
39725	2496	39875	2511	20.09	2.02	22.11	162.55	2
40545	2585.5	40695	2600.5	19.62	2.02	21.64	145.88	2
41365	2667.5	41515	2682.5	19.17	2.02	21.19	131.52	2



Test Report No.: W7L-P21110008RF17

LTE BAND CA_41C 10M+20M QPSK								
Channel	Frequency (MHz)	Channel	Frequency (MHz)	Conducted Power (dBm)	Gain (dB)	EIRP (dBm)	EIRP (mW)	Lmit (W)
39705	2501.5	39849	2515.9	22.01	2.02	24.03	252.93	2
40526	2583.6	40670	2598	21.36	2.02	23.38	217.77	2
41346	2665.6	41490	2680	20.83	2.02	22.85	192.75	2
LTE BAND CA_41C 10M+20M 16QAM								
Channel	Frequency (MHz)	Channel	Frequency (MHz)	Conducted Power (dBm)	Gain (dB)	EIRP (dBm)	EIRP (mW)	Lmit (W)
39705	2501.5	39849	2515.9	20.93	2.02	22.95	197.24	2
40526	2583.6	40670	2598	20.51	2.02	22.53	179.06	2
41346	2665.6	41490	2680	19.87	2.02	21.89	154.53	2
LTE BAND CA_41C 10M+20M 64QAM								
Channel	Frequency (MHz)	Channel	Frequency (MHz)	Conducted Power (dBm)	Gain (dB)	EIRP (dBm)	EIRP (mW)	Lmit (W)
39705	2501.5	39849	2515.9	20.14	2.02	22.16	164.44	2
40526	2583.6	40670	2598	19.64	2.02	21.66	146.55	2
41346	2665.6	41490	2680	19.2	2.02	21.22	132.43	2



Test Report No.: W7L-P21110008RF17

LTE BAND CA_41C 20M+10M QPSK								
Channel	Frequency (MHz)	Channel	Frequency (MHz)	Conducted Power (dBm)	Gain (dB)	EIRP (dBm)	EIRP (mW)	Lmit (W)
39750	2506	39894	2520.4	22.02	2.02	24.04	253.51	2
40571	2588.1	40715	2602.5	21.4	2.02	23.42	219.79	2
41391	2670.1	41535	2684.5	20.85	2.02	22.87	193.64	2
LTE BAND CA_41C 20M+10M 16QAM								
Channel	Frequency (MHz)	Channel	Frequency (MHz)	Conducted Power (dBm)	Gain (dB)	EIRP (dBm)	EIRP (mW)	Lmit (W)
39750	2506	39894	2520.4	20.96	2.02	22.98	198.61	2
40571	2588.1	40715	2602.5	20.56	2.02	22.58	181.13	2
41391	2670.1	41535	2684.5	19.89	2.02	21.91	155.24	2
LTE BAND CA_41C 20M+10M 64QAM								
Channel	Frequency (MHz)	Channel	Frequency (MHz)	Conducted Power (dBm)	Gain (dB)	EIRP (dBm)	EIRP (mW)	Lmit (W)
39750	2506	39894	2520.4	20.16	2.02	22.18	165.2	2
40571	2588.1	40715	2602.5	19.67	2.02	21.69	147.57	2
41391	2670.1	41535	2684.5	19.23	2.02	21.25	133.35	2



Test Report No.: W7L-P21110008RF17

LTE BAND CA_41C 15M+20M QPSK								
Channel	Frequency (MHz)	Channel	Frequency (MHz)	Conducted Power (dBm)	Gain (dB)	EIRP (dBm)	EIRP (mW)	Lmit (W)
39728	2503.8	39899	2520.9	21.99	2.02	24.01	251.77	2
40523	2583.3	40694	2600.4	21.38	2.02	23.4	218.78	2
41319	2662.9	41490	2680	20.82	2.02	22.84	192.31	2
LTE BAND CA_41C 15M+20M 16QAM								
Channel	Frequency (MHz)	Channel	Frequency (MHz)	Conducted Power (dBm)	Gain (dB)	EIRP (dBm)	EIRP (mW)	Lmit (W)
39728	2503.8	39899	2520.9	20.95	2.02	22.97	198.15	2
40523	2583.3	40694	2600.4	20.52	2.02	22.54	179.47	2
41319	2662.9	41490	2680	19.87	2.02	21.89	154.53	2
LTE BAND CA_41C 15M+20M 64QAM								
Channel	Frequency (MHz)	Channel	Frequency (MHz)	Conducted Power (dBm)	Gain (dB)	EIRP (dBm)	EIRP (mW)	Lmit (W)
39728	2503.8	39899	2520.9	20.13	2.02	22.15	164.06	2
40523	2583.3	40694	2600.4	19.62	2.02	21.64	145.88	2
41319	2662.9	41490	2680	19.21	2.02	21.23	132.74	2



Test Report No.: W7L-P21110008RF17

LTE BAND CA_41C 20M+15M QPSK								
Channel	Frequency (MHz)	Channel	Frequency (MHz)	Conducted Power (dBm)	Gain (dB)	EIRP (dBm)	EIRP (mW)	Lmit (W)
39750	2506	39921	2523.1	22.13	2.02	24.15	260.02	2
40546	2585.6	40717	2602.7	21.41	2.02	23.43	220.29	2
41341	2665.1	41512	2682.2	20.87	2.02	22.89	194.54	2
LTE BAND CA_41C 20M+15M 16QAM								
Channel	Frequency (MHz)	Channel	Frequency (MHz)	Conducted Power (dBm)	Gain (dB)	EIRP (dBm)	EIRP (mW)	Lmit (W)
39750	2506	39921	2523.1	20.98	2.02	23	199.53	2
40546	2585.6	40717	2602.7	20.54	2.02	22.56	180.3	2
41341	2665.1	41512	2682.2	19.9	2.02	21.92	155.6	2
LTE BAND CA_41C 20M+15M 64QAM								
Channel	Frequency (MHz)	Channel	Frequency (MHz)	Conducted Power (dBm)	Gain (dB)	EIRP (dBm)	EIRP (mW)	Lmit (W)
39750	2506	39921	2523.1	20.14	2.02	22.16	164.44	2
40546	2585.6	40717	2602.7	19.66	2.02	21.68	147.23	2
41341	2665.1	41512	2682.2	19.23	2.02	21.25	133.35	2



Test Report No.: W7L-P21110008RF17

LTE BAND CA_41C 20M+20M QPSK								
Channel	Frequency (MHz)	Channel	Frequency (MHz)	Conducted Power (dBm)	Gain (dB)	EIRP (dBm)	EIRP (mW)	Lmit (W)
39750	2506	39948	2525.8	22.13	2.02	24.15	260.02	2
40521	2583.1	40719	2602.9	22.03	2.02	24.05	254.1	2
41292	2660.2	41490	2680	21.38	2.02	23.4	218.78	2
LTE BAND CA_41C 20M+20M 16QAM								
Channel	Frequency (MHz)	Channel	Frequency (MHz)	Conducted Power (dBm)	Gain (dB)	EIRP (dBm)	EIRP (mW)	Lmit (W)
39750	2506	39948	2525.8	21.53	2.02	23.55	226.46	2
40521	2583.1	40719	2602.9	20.93	2.02	22.95	197.24	2
41292	2660.2	41490	2680	20.61	2.02	22.63	183.23	2
LTE BAND CA_41C 20M+20M 64QAM								
Channel	Frequency (MHz)	Channel	Frequency (MHz)	Conducted Power (dBm)	Gain (dB)	EIRP (dBm)	EIRP (mW)	Lmit (W)
39750	2506	39948	2525.8	20.88	2.02	22.9	194.98	2
40521	2583.1	40719	2602.9	20.05	2.02	22.07	161.06	2
41292	2660.2	41490	2680	19.83	2.02	21.85	153.11	2

3.2 FREQUENCY STABILITY MEASUREMENT

3.2.1 LIMITS OF FREQUENCY STABILITY MEASUREMENT

The frequency stability shall be sufficient to ensure that the fundamental emissions stay within the authorized bands of operation.

3.2.2 TEST PROCEDURE

- a. Device is placed at the oven room. The oven room could control the temperatures and humidity. Power warm up is at least 15 min and power applied should perform before recording frequency error.
- b. EUT is connected the external power supply to control the DC input power. The test voltage range is from minimum to maximum working voltage. Each step shall be record the frequency error rate.
- c. The temperature range step is 10 degrees in this test items. All temperature levels shall be hold the $\pm 0.5^{\circ}\text{C}$ during the measurement testing. The each temperature step shall be at least 0.5 hours, consider the EUT could be test under the stability condition.

NOTE: The frequency error was recorded frequency error from the communication simulator.

3.2.3 TEST SETUP

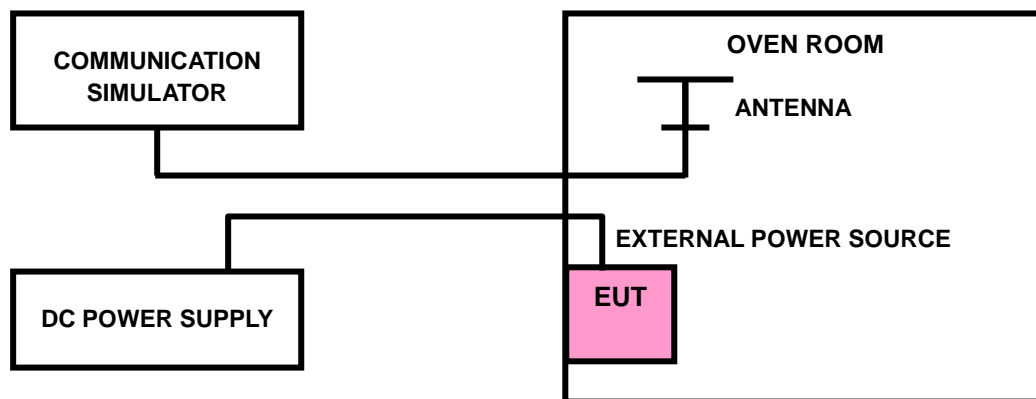

3.2.4 TEST RESULTS

LTE BAND CA_41C

LTE BAND CA_41C channel and Frequency List					
BW(MHz)	Channel/Frequncy(MHz)		Lowest	Middle	Highest
5+20	PCC	channel	39683	40528	41373
		Frequncy	2499.3	2583.8	2668.3
	SCC	channel	39800	40645	41490
		Frequncy	2511	2595.5	2680
10+15	PCC	channel	39703	40549	41395
		Frequncy	2501.3	2585.9	2670.5
	SCC	channel	39823	40669	41515
		Frequncy	2513.3	2597.9	2682.5
10+20	PCC	channel	39705	40526	41346
		Frequncy	2501.5	2583.6	2665.6
	SCC	channel	39849	40670	41490
		Frequncy	2515.9	2598.0	2680
15+10	PCC	channel	39725	40571	41417
		Frequncy	2503.5	2588.1	2672.7
	SCC	channel	39845	40691	41537
		Frequncy	2515.5	2600.1	2684.7
15+15	PCC	channel	39725	40545	41365
		Frequncy	2503.5	2585.5	2667.5
	SCC	channel	39875	40695	41515
		Frequncy	2518.5	2600.5	2682.5
15+20	PCC	channel	39728	40523	41319
		Frequncy	2503.8	2583.3	2662.9
	SCC	channel	39899	40694	41490
		Frequncy	2520.9	2600.4	2680
20+5	PCC	channel	39750	40595	41440
		Frequncy	2506	2590.5	2675
	SCC	channel	29867	40712	41557
		Frequncy	2517.7	2602.2	2686.7



BUREAU
VERITAS

Test Report No.: W7L-P21110008RF17

20+10	PCC	channel	39750	40571	41391
		Frequncy	2506	2588.1	2670.1
	SCC	channel	39894	40715	41535
		Frequncy	2520.4	2602.5	2684.5
20+15	PCC	channel	39750	40546	41341
		Frequncy	2506	2585.6	2665.1
	SCC	channel	39921	40717	41512
		Frequncy	2523.1	2602.7	2682.2
20+20	PCC	channel	39750	40521	41292
		Frequncy	2506	2583.1	2660.2
	SCC	channel	39948	40719	41490
		Frequncy	2525.8	2602.9	2680

3.3 OCCUPIED BANDWIDTH MEASUREMENT

3.3.1 LIMITS OF OCCUPIED BANDWIDTH MEASUREMENT

The width of a frequency band such that, below the lower and above the upper frequency limits, the mean powers emitted are each equal to a specified percentage 0.5 %of the total mean power of a given emission.

3.3.2 TEST SETUP

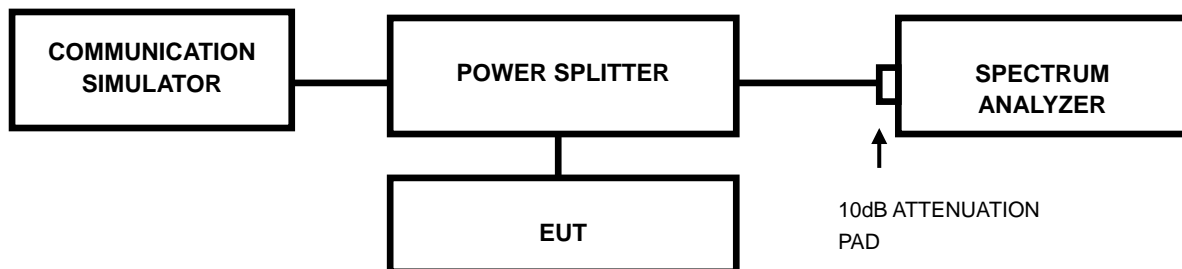

3.3.3 TEST PROCEDURES

- The conducted occupied bandwidth used the power splitter via EUT RF power connector between simulation base station and spectrum analyzer.
- Use OBW measurement function of Spectrum analyzer to measure 99 % occupied bandwidth.

3.3.4 TEST RESULTS

LTE BAND 41 CA				
CHANNEL BANDWIDTH: 5MHz+20MHz				
CHANNEL		99% OCCUPIED BANDWIDTH (MHz)		
PCC	SCC	QPSK	16QAM	64QAM
39683	39800	23.355	23.258	23.216
40528	40645	23.390	23.240	23.211
41373	41490	23.321	23.233	23.164
CHANNEL		26dB BANDWIDTH (MHz)		
PCC	SCC	QPSK	16QAM	64QAM
39683	39800	25.19	24.99	24.89
40528	40645	25.29	25.03	24.89
41373	41490	25.40	24.99	24.92





LTE BAND 41 CA				
CHANNEL BANDWIDTH: 10MHz+15MHz				
CHANNEL		99% OCCUPIED BANDWIDTH (MHz)		
PCC	SCC	QPSK	16QAM	64QAM
39703	39823	23.506	23.562	23.496
40549	40669	23.512	23.520	23.622
41395	41515	23.500	23.512	23.599
CHANNEL	CHANNEL	26dB BANDWIDTH (MHz)		
PCC	SCC	QPSK	16QAM	64QAM
39703	39823	25.88	25.54	25.50
40549	40669	25.56	25.44	25.46
41395	41515	25.63	25.41	25.60





Test Report No.: W7L-P21110008RF17

LTE BAND 41 CA				
CHANNEL BANDWIDTH: 10MHz+20MHz				
CHANNEL		99% OCCUPIED BANDWIDTH (MHz)		
PCC	SCC	QPSK	16QAM	64QAM
39705	39849	28.148	28.109	28.167
40526	40670	28.155	28.090	28.044
41346	41490	28.080	28.072	28.115
CHANNEL	CHANNEL	26dB BANDWIDTH (MHz)		
PCC	SCC	QPSK	16QAM	64QAM
39705	39849	30.08	30.30	29.91
40526	40670	29.93	30.01	30.42
41346	41490	30.13	29.97	29.93

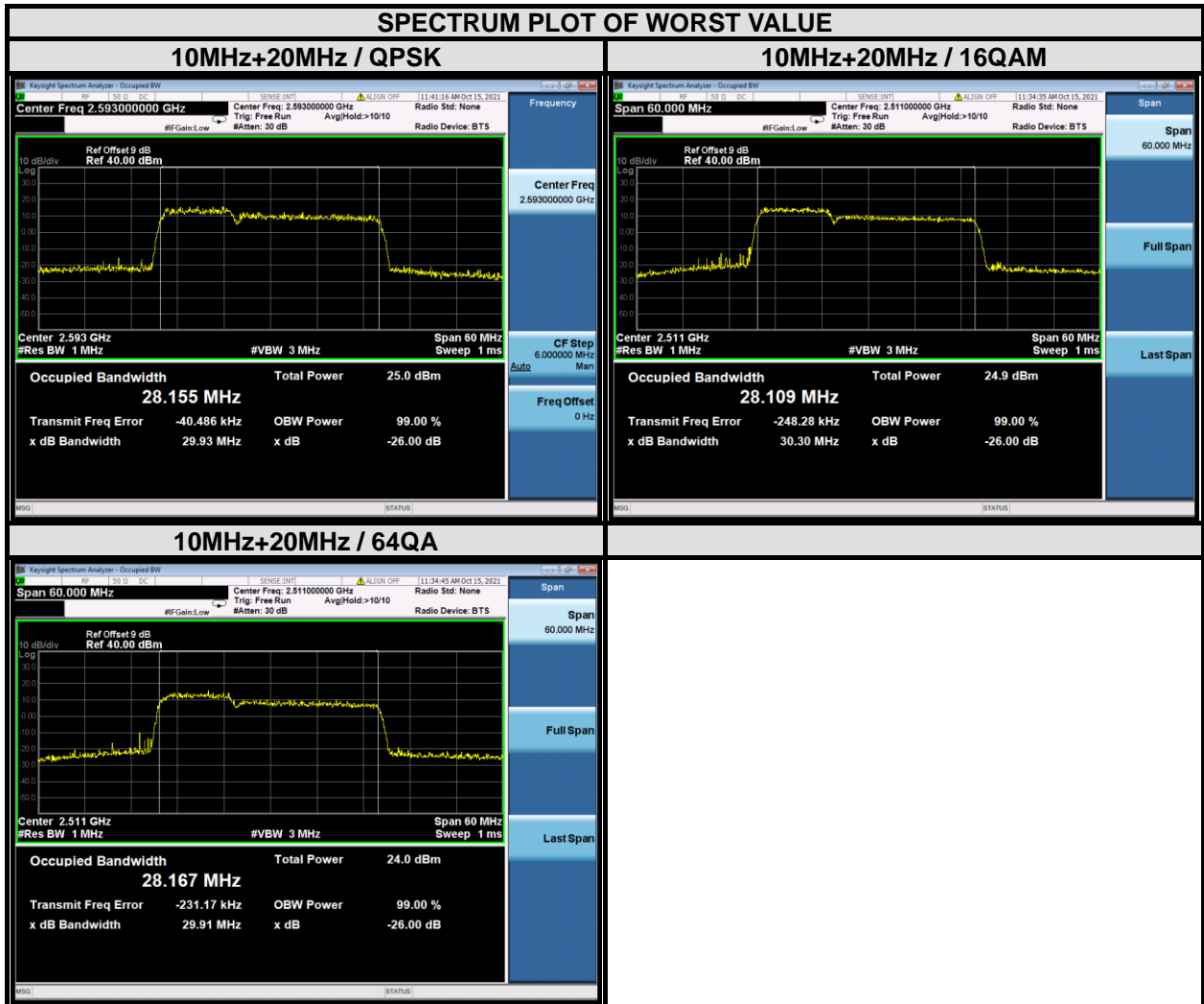



LTE BAND 41 CA				
CHANNEL BANDWIDTH: 15MHz +10MHz				
99% OCCUPIED BANDWIDTH (MHz)				
CHANNEL	CHANNEL	QPSK	16QAM	64QAM
39725	39845	23.700	23.686	23.690
40571	40691	23.694	23.682	23.599
41417	41537	23.707	23.636	23.672
26dB BANDWIDTH (MHz)				
CHANNEL	CHANNEL	QPSK	16QAM	64QAM
39725	39845	25.92	25.66	25.70
40571	40691	25.67	25.50	25.46
41417	41537	25.65	25.55	25.55

