

FCC 2.1093 SAR Test Report

for

LG Electronics Inc.

**222, LG-roJinwi-myeon, Pyeongtaek-Si, Gyeonggi-Do,
451-713, Korea**

Product Name : Notebook Computer
Model Name : 14Z995
Brand : LG
FCC ID : BEJNT-14Z995

**Prepared by: : AUDIX Technology Corporation,
EMC Department**



The test report is based on a single evaluation of one sample of the above-mentioned products. It does not imply an assessment of the whole production and does not permit the use of the test lab logo. The report must not be used by the client to claim product certification, approval, or endorsement by NVLAP, NIST, or any agency of the U.S. Government.

TABLE OF CONTENTS

| Description | Page |
|--|-----------|
| TEST REPORT CERTIFICATION..... | 3 |
| 1. REVISION RECORD OF TEST REPORT | 4 |
| 2. SUMMARY OF TEST RESULTS | 5 |
| 3. GENERAL INFORMATION | 6 |
| 3.1. Description of Application | 6 |
| 3.2. Description of EUT | 7 |
| 3.3. Antenna Information | 8 |
| 3.4. EUT Specifications Assessed in Current Report | 9 |
| 3.5. Description of Key Components | 11 |
| 3.6. Test Environment | 13 |
| 3.7. Description of Test Facility | 13 |
| 3.8. Measurement Uncertainty | 14 |
| 4. MEASUREMENT EQUIPMENT LIST | 16 |
| 5. SAR MEASUREMENT SYSTEM | 17 |
| 5.1. Definition of Specific Absorption Rate (SAR)..... | 17 |
| 5.2. SPEAG DASY System | 17 |
| 5.3. SAR System Verification | 25 |
| 5.4. SAR Measurement Procedure | 35 |
| 6. SAR MEASUREMENT EVALUATION | 38 |
| 6.1. EUT Configuration and Setting | 38 |
| 6.2. EUT Testing Position | 39 |
| 6.3. Tissue Calibration Result | 40 |
| 6.4. SAR Exposure Limits | 41 |
| 6.5. Conducted Power Measurement | 42 |
| 6.6. SAR Test Result | 50 |

APPENDIX A TEST DATA AND PLOTS

APPENDIX B TEST PHOTOGRAPHS

TEST REPORT CERTIFICATION

Applicant : LG Electronics Inc.
Manufacturer : LG Electronics Inc.
Factory #1 : LG Electronics Nanjing New Technology Co., Ltd.
Factory #2 : SEO HEUNG ELECTRONICS CO LTD
EUT Description
(1) Product : Notebook Computer
(2) Model : 14Z995
(3) Brand : LG
(4) Power Supply: DC 19V, 2.53A

Applicable Standards:

47CFR FCC Part 2 (§2.1093)
IEEE 1528-2013

KDB 447498 D01 General RF Exposure Guidance v06
KDB 865664 D01 SAR Measurement 100MHz to 6GHz v01r04

Audix Technology Corp. tested the equipment mentioned in accordance with the requirements set forth in the above standards. Test results indicate that the equipment tested is capable of demonstrating compliance with the requirements as documented within this report.

Audix Technology Corp. does not assume responsibility for any conclusions and generalizations drawn from the test results with regard to other specimens and samples.

Date of Report: 2020. 01. 17

Reviewed by:

Sabrina Wang

(Sabrina Wang/Administrator)

Approved by:

Johnny Hsueh

(Johnny Hsueh/Section Manager)

1. REVISION RECORD OF TEST REPORT

| Edition No | Issued Date | Revision Summary | Report Number |
|------------|--------------|------------------|---------------|
| 0 | 2020. 01. 17 | Original Report | EM-SR190018 |

2. SUMMARY OF TEST RESULTS

| Mode | | Highest measured Body SAR _{1g} | Highest Reported Body SAR _{1g} |
|-----------|-----------|--|--|
| WLAN 2.4G | ANT: Main | 0.258 (W/kg) | 0.29 (W/kg) |
| | ANT: AUX | 0.184 (W/kg) | 0.20 (W/kg) |
| WLAN 5G | ANT: Main | 1.110 (W/kg) | 1.12 (W/kg) |
| | ANT: AUX | 0.654 (W/kg) | 0.66 (W/kg) |
| BT | ANT: AUX | 0.015 (W/kg) | 0.02 (W/kg) |

Note: The SAR limit (SAR_{1g} 1.6 W/kg) for general population / uncontrolled exposure is specified in FCC 47 CFR part 2 (2.1093).

| Highest Simultaneous Transmission SAR | Reported Body SAR _{1g} |
|--|---------------------------------|
| WLAN 2.4G ANT Main+ WLAN 2.4G ANT AUX | 0.49 (W/kg) |
| WLAN 2.4G ANT AUX+ BT ANT AUX | 0.22 (W/kg) |
| WLAN 5G ANT AUX+ BT ANT AUX | 1.14 (W/kg) |
| WLAN 5G ANT Main (5745MHz)+ WLAN 5 ANT AUX (5745MHz) | 1.50 (W/kg) |
| WLAN 5G ANT Main (5745MHz)+ WLAN 5 ANT AUX (5745MHz)+ BT ANT AUX | 1.52 (W/kg) |

Note: 1. The SAR limit (SAR_{1g} 1.6 W/kg) for general population / uncontrolled exposure is specified in FCC 47 CFR part 2 (2.1093).
2. It is calculated from scale SAR.

3. GENERAL INFORMATION

3.1. Description of Application

| | |
|--------------|---|
| Applicant | LG Electronics Inc. 222, LG-roJinwi-myeon, Pyeongtaek-Si, Gyeonggi-Do, 451-713, Korea |
| Manufacturer | LG Electronics Inc. 222, LG-roJinwi-myeon, Pyeongtaek-Si, Gyeonggi-Do, 451-713, Korea |
| Factory #1 | LG Electronics Nanjing New Technology Co., Ltd. No.346,Yaoxin Road, Economic & Technical Development Zone, Nanjing, China. |
| Factory #2 | SEO HEUNG ELECTRONICS CO LTD 55 Asan valley Seo-ro, Dunpo-myeon,Asan-si, Chungcheongnam-do, 31409 Korea |
| Product | Notebook Computer The product has two colors (Dark Silver and White). |
| Model | 14Z995 |
| Brand | LG |

3.2. Description of EUT

| | | |
|------------------------|---|------|
| Test Model | 14Z995 | |
| Serial Number | N/A | |
| Power Rating | DC 19V, 2.53A | |
| Software Version | N/A | |
| RF Features | WLAN: 802.11 a/b/g/n/ac/ax Bluetooth: BT and BLE (BT 5.0) | |
| Transmit Type | 2.4 GHz | |
| | 802.11b | 1T1R |
| | 802.11g | 1T1R |
| | 802.11n-HT20 | 2T2R |
| | 802.11n-HT40 | 2T2R |
| | 802.11ax-HE20 | 2T2R |
| | 802.11ax-HE40 | 2T2R |
| | BT/BLE | 1T1R |
| | UNII Bands | |
| | 802.11a | 1T1R |
| | 802.11n-HT20/802.11ac-VHT20/802.11ax-HE20 | 2T2R |
| | 802.11n-HT40/802.11ac-VHT40/802.11ax-HE40 | 2T2R |
| | 802.11ac-VHT80/802.11ax-HE80 | 2T2R |
| | 802.11ac-VHT160/802.11ax-HE160 | 2T2R |
| Sample Status | Production | |
| Date of Receipt | 2019. 12. 16 | |
| Date of Test | 2019. 12. 18~ 2020. 01. 17 | |
| Interface Ports of EUT | <ul style="list-style-type: none"> • One Micro SD Card Slot • One Earphone Port • Two USB 3.0 Ports • One USB Type C Port • One HDMI Port • One DC Input Port | |
| Accessories Supplied | <ul style="list-style-type: none"> • AC Adapter • LAN Gender | |

3.3. Antenna Information

| No. | Antenna Part Number | Manufacture | Antenna Type | Frequency (MHz) | Max Gain (dBi) |
|-----|----------------------------|-------------|--------------|-----------------|----------------|
| 1 | WA-F-LBLB-04-058 (Main) | INPAQ | FPCB | 2400 | 1.94 |
| | | | | 2450 | 2.72 |
| | | | | 2500 | 1.20 |
| | | | | 5100 | 1.35 |
| | | | | 5400 | 3.06 |
| | | | | 5800 | 2.10 |
| 2 | WA-F-LBLB-04-058 (AUX) | INPAQ | FPCB | 2400 | 2.79 |
| | | | | 2450 | 2.29 |
| | | | | 2500 | 1.90 |
| | | | | 5100 | 2.82 |
| | | | | 5400 | 1.12 |
| | | | | 5800 | 0.58 |

3.4. EUT Specifications Assessed in Current Report

| 2.4GHz | | |
|--------------|-------------------------|----------------|
| Mode | Fundamental Range (MHz) | Channel Number |
| 802.11b | 2412-2472 | 13 |
| 802.11g | | 13 |
| 802.11n-HT20 | | 13 |
| 802.11n-HT40 | 2422-2462 | 9 |
| Bluetooth | 2402-2480 | 79 |
| BLE | 2402-2480 | 40 |

| 5GHz | | | |
|--|-----------|-------------------------|----------------|
| Mode | UNII Band | Fundamental Range (MHz) | Channel Number |
| 802.11a | I | 5180-5240 | 4 |
| | II-2A | 5260-5320 | 4 |
| | II-2C | 5500-5720 | 12 |
| | III | 5745-5825 | 5 |
| 802.11n-HT20/ 802.11ac-VHT20 802.11ax-HE20 | I | 5180-5240 | 4 |
| | II-2A | 5260-5320 | 4 |
| | II-2C | 5500-5720 | 12 |
| | III | 5745-5825 | 5 |
| 802.11n-HT40/ 802.11ac-VHT40 802.11ax-HE40 | I | 5190-5230 | 2 |
| | II-2A | 5270-5310 | 2 |
| | II-2C | 5510-5710 | 6 |
| | III | 5755-5795 | 2 |
| 802.11ac-VHT80 802.11ax-HE80 | I | 5210 | 1 |
| | II-2A | 5290 | 1 |
| | II-2C | 5530-5690 | 3 |
| | III | 5775 | 1 |
| 802.11ac-VHT160 /802.11ax-HE160 | I | 5250 | 1 |
| | II-2A | | |
| | II-2C | 5570 | 1 |

Remark: UNII Band II-2A and II-2C (DFS Function, Slave/no In service monitor, no Ad-Hoc mode)

| Mode | Modulation | Data Rate (Mbps) |
|-----------------|---|------------------|
| 802.11b | DSSS (DBPSK/DQPSK/CCK) | Up to 11 |
| 802.11g | OFDM (BPSK/QPSK/16QAM/64QAM) | Up to 54 |
| 802.11a | OFDM (BPSK/QPSK/16QAM/64QAM) | Up to 54 |
| 802.11n-HT20 | OFDM (BPSK/QPSK/16QAM/64QAM) | Up to 144.4 |
| 802.11n-HT40 | | Up to 300 |
| 802.11ac-VHT20 | OFDM (BPSK/QPSK/16QAM/64QAM/256QAM) | Up to 173.3 |
| 802.11ac-VHT40 | | Up to 400 |
| 802.11ac-VHT80 | | Up to 866.7 |
| 802.11ac-VHT160 | | Up to 1733.3 |
| 802.11ax-HE20 | OFDMA (BPSK/ QPSK/ 16QAM/ 64QAM/ 256QAM/1024QAM) | Up to 287 |
| 802.11ax-HE40 | | Up to 574 |
| 802.11ax-HE80 | | Up to 1201 |
| 802.11ax-HE160 | | Up to 2402 |
| Bluetooth | FHSS (GFSK, $\pi/4$ DQPSK, 8-DPSK) | Up to 3 |
| BLE | GFSK (1M, 2M, PHY Coded S8, PHY Coded S2) | Up to 2 |

3.5. Description of Key Components

3.5.1. For the All Component Lists

| Item | Supplier | Model / Type | Character | |
|--|--|--------------------------------------|---|--|
| System | Microsoft | Win10 Home | --- | |
| | | Win10 Pro | --- | |
| Main Board | LG | 14_15Z990/995 Main B/D | Manufacturer: #1 HannstarBoardTech(Jiang Yin)Corp.,Ltd. #2 Elec&Eltek Company (MCO) Limited | |
| SUB Board | LG | 14Z990 WLAN SUB B/D | Manufacturer: #1 HannstarBoardTech(Jiang Yin)Corp.,Ltd. #2 Elec&Eltek Company (MCO) Limited | |
| CPU (Socket:FCBGA1528) | Intel | i5-10210U | 1.6GHz, up to 4.2GHz | |
| | | i7-10510U | 1.8GHz, up to 4.9GHz | |
| 14" LCD Panel | LG Display | LP140WFA-SPY1 | Resolution: 1920X1080, 60HzFHD IPS | |
| Storage (SSD) | Samsung | MZ-VLB2560 | 256GB | |
| | | MZ-VLB512B | 512GB | |
| Memory (RAM) | Samsung | - | 8GB DDR4 (On Board) | |
| | SK hynix | - | 8GB DDR4 (On Board) | |
| | Samsung | - | 8GB DDR4 SODIMM (On Card) | |
| Battery Pack | LG | LBS1224E | DC 7.7V, 72Wh, Typ 9450mAh | |
| WLAN Combo Card | Intel | AX201D2W | WLAN and BT, 2x2 CNVi1216 FCC ID: PD9AX201NG IC: 1000M-AX201NG | |
| WLAN Combo Antenna | LG (INPAQ) | WA-F-LBLB-04-058 | FPCB Type, Main: Black, Aux: Gray | |
| Web Camera | Chicony | CKFIH2821005290LH | With two microphones | |
| | | CKFIH28-121005290LH | With one microphone | |
| | Luxvisions | 7BF109N2DC | With two microphones | |
| | | 7BF109N2DD | With one microphone | |
| Keyboard | LG | SN3871BL1 (White) | --- | |
| | | SN3871BL (Black) | --- | |
| LAN Gender (Type C to LAN) | SUZHOU MEC ELECTRONICS | 80-5946-111 | (White) 10/100 Megabit Ethernet | |
| | | 80-5946-101 | (Black) 10/100 Megabit Ethernet | |
| | ARIN TECH CO. LTD | GD-08MF-36-WH-LP10 | (White) 10/100Megabit Ethernet | |
| | | GD-08MF-36-BK-LP11 | (Black) 10/100 Megabit Ethernet | |
| | Type C to LAN: Shielded, Undetached, 0.12m | | | |
| | SUZHOU MEC ELECTRONICS | 80-5946-200 | (White) 10/100/1000 Megabit Ethernet | |
| 80-5946-210 | | (Black) 10/100/1000 Megabit Ethernet | | |
| Type C to LAN: Shielded, Undetached, 0.13m | | | | |
| AC Adapter (48W) | LG (HONOR) | ADS-48MS-19-2 19048E | I/P: AC 100-240V, 50-60Hz, 1.5A, O/P: DC 19V, 2.53A | |
| | DC Power Cord: Non-Shielded, Undetached, 1.5m AC Power Cord: Non-Shielded, Detached, 1.55m (2C) | | | |

Remark: For more detailed features description, please refer to the manufacturer's specifications or the user manual.

3.5.2. The EUT collocates with following worst components, which are used to establish a basic configuration of system during test:

| SKU | | 1 |
|---------------------------|----------------------------------|---|
| Main Board | 14_15Z990/995 Main B/D | V |
| SUB Board | 14Z990 WLAN SUB B/D | V |
| CPU | i7-10510U | V |
| 14" LCD Panel | LG Display, LP140WFA-SPY1 | V |
| Storage (SSD) | Samsung, 512GB | V |
| Memory (RAM) | SK Hynix, 8GB (On Board) | V |
| | Samsung, 8GB (On Card) | V |
| Battery Pack | LG, LBS1224E | V |
| WLAN Combo Card | Intel, AX201D2W | V |
| WLAN Combo Antenna | LG (INPAQ), WA-F-LBLB-04-058 | V |
| Keyboard | TIC, SN3871BL (Black) | V |
| Web Camera | Chicony, CKFIH2821005290LH | V |
| AC Adapter | LG (HONOR), ADS-48MS-19-2 19048E | V |
| Type C Link to LAN Gender | MEC, 80-5946-101 (Black) | V |

3.6. Test Environment

Ambient conditions in the laboratory:

| Item | Require | Actual |
|------------------|---------|--------|
| Temperature (°C) | 18-25 | 22 ±2 |
| Humidity (%RH) | 30-70 | 48 ± 2 |

3.7. Description of Test Facility

| | |
|-------------------|---|
| Name of Test Firm | Audix Technology Corporation / EMC Department No. 53-11, Dingfu, Linkou Dist., New Taipei City 244, Taiwan Tel: +886-2-26092133 Fax: +886-2-26099303 Website : www.audixtech.com Contact e-mail: attemc_report@audixtech.com |
| Accreditations | The laboratory is accredited by following organizations under ISO/IEC 17025:2017 (1) NVLAP(USA) NVLAP Lab Code 200077-0 (2) TAF(Taiwan) No. 1724 |
| Test Facilities | FCC OET Designation Number under APEC MRA by NCC is : TW1724 (1) SAR Room |

3.8. Measurement Uncertainty

| DASY5 Uncertainty | | | | | | | | |
|--|---------------|-------------|------------|---------|----------|----------------|-----------------|-----------------------|
| According to IEEE 1528-2013 and IEC 62209-1/2016 (0.3 - 6 GHz range) | | | | | | | | |
| Error Description | Uncert. value | Prob. Dist. | Div. | (ci) 1g | (ci) 10g | Std. Unc. (1g) | Std. Unc. (10g) | (vi) v _{eff} |
| Measurement System | | | | | | | | |
| Probe Calibration | ±6.0% | N | 1 | 1 | 1 | ±6.0% | ±6.0% | ∞ |
| Axial Isotropy | ±4.7% | R | $\sqrt{3}$ | 0.7 | 0.7 | ±1.9% | ±1.9% | ∞ |
| Hemispherical Isotropy | ±9.6% | R | $\sqrt{3}$ | 0.7 | 0.7 | ±3.9% | ±3.9% | ∞ |
| Boundary Effects | ±1.0% | R | $\sqrt{3}$ | 1 | 1 | ±0.6% | ±0.6% | ∞ |
| Linearity | ±4.7% | R | $\sqrt{3}$ | 1 | 1 | ±2.7% | ±2.7% | ∞ |
| System Detection Limits | ±1.0% | R | $\sqrt{3}$ | 1 | 1 | ±0.6% | ±0.6% | ∞ |
| Readout Electronics | ±0.3% | N | 1 | 1 | 1 | ±0.3% | ±0.3% | ∞ |
| Response Time | ±0.8% | R | $\sqrt{3}$ | 1 | 1 | ±0.5% | ±0.5% | ∞ |
| Integration Time | ±2.6% | R | $\sqrt{3}$ | 1 | 1 | ±1.5% | ±1.5% | ∞ |
| RF Ambient Noise | ±3.0% | R | $\sqrt{3}$ | 1 | 1 | ±1.7% | ±1.7% | ∞ |
| RF Ambient Reflections | ±3.0% | R | $\sqrt{3}$ | 1 | 1 | ±1.7% | ±1.7% | ∞ |
| Probe Positioner | ±0.4% | R | $\sqrt{3}$ | 1 | 1 | ±0.2% | ±0.2% | ∞ |
| Probe Positioning | ±2.9% | R | $\sqrt{3}$ | 1 | 1 | ±1.7% | ±1.7% | ∞ |
| Max. SAR Eval. | ±1.0% | R | $\sqrt{3}$ | 1 | 1 | ±0.6% | ±0.6% | ∞ |
| Test Sample Related | | | | | | | | |
| Device Positioning | ±2.9% | N | 1 | 1 | 1 | ±2.9% | ±2.9% | 145 |
| Device Holder | ±3.6% | N | 1 | 1 | 1 | ±3.6% | ±3.6% | 5 |
| Power Drift | ±5.0% | R | $\sqrt{3}$ | 1 | 1 | ±2.9% | ±2.9% | ∞ |
| Phantom and Setup | | | | | | | | |
| Phantom Uncertainty | ±4.0% | R | $\sqrt{3}$ | 1 | 1 | ±2.3% | ±2.3% | ∞ |
| Liquid Conductivity (target) | ±5.0% | R | $\sqrt{3}$ | 0.64 | 0.43 | ±1.8% | ±1.2% | ∞ |
| Liquid Conductivity (meas.) | ±2.5% | N | 1 | 0.64 | 0.43 | ±1.6% | ±1.1% | ∞ |
| Liquid Permittivity (target) | ±5.0% | R | $\sqrt{3}$ | 0.6 | 0.49 | ±1.7% | ±1.4% | ∞ |
| Liquid Permittivity (meas.) | ±2.5% | N | 1 | 0.6 | 0.49 | ±1.5% | ±1.2% | ∞ |
| Combined Std. Uncertainty | | | | | | ±11% | ±10.8% | 387 |
| Expanded STD Uncertainty | | | | | | ±22% | ±21.5% | |

| DASY5 Uncertainty According to IEC 62209-2/2010 (30 MHz - 6 GHz range) | | | | | | | | |
|--|---------------|-------------|------|---------|----------|----------------|-----------------|-----------------------|
| Error Description | Uncert. value | Prob. Dist. | Div. | (ci) 1g | (ci) 10g | Std. Unc. (1g) | Std. Unc. (10g) | (vi) v _{eff} |
| Measurement System | | | | | | | | |
| Probe Calibration | ±6.0% | N | 1 | 1 | 1 | ±6.0% | ±6.0% | ∞ |
| Axial Isotropy | ±4.7% | R | √3 | 0.7 | 0.7 | ±1.9% | ±1.9% | ∞ |
| Hemispherical Isotropy | ±9.6% | R | √3 | 0.7 | 0.7 | ±3.9% | ±3.9% | ∞ |
| Boundary Effects | ±1.0% | R | √3 | 1 | 1 | ±0.6% | ±0.6% | ∞ |
| Linearity | ±4.7% | R | √3 | 1 | 1 | ±2.7% | ±2.7% | ∞ |
| System Detection Limits | ±1.0% | R | √3 | 1 | 1 | ±0.6% | ±0.6% | ∞ |
| Readout Electronic | ±0.3% | N | 1 | 1 | 1 | ±0.3% | ±0.3% | ∞ |
| Response Time | ±0.8% | R | √3 | 1 | 1 | ±0.5% | ±0.5% | ∞ |
| Integration Time | ±2.6% | R | √3 | 1 | 1 | ±1.5% | ±1.5% | ∞ |
| RF Ambient Noise | ±3.0% | R | √3 | 1 | 1 | ±1.7% | ±1.7% | ∞ |
| RF Ambient Reflections | ±3.0% | R | √3 | 1 | 1 | ±1.7% | ±1.7% | ∞ |
| Probe Positioner | ±0.4% | R | √3 | 1 | 1 | ±0.2% | ±0.2% | ∞ |
| Probe Positioning | ±2.9% | R | √3 | 1 | 1 | ±1.7% | ±1.7% | ∞ |
| Modulation Response | ±2.5% | R | √3 | 1 | 1 | ±1.45 % | ±1.45 % | ∞ |
| Post-processing | ±3.8% | R | √3 | 1 | 1 | ±2.2% | ±2.2% | ∞ |
| Test Sample Related | | | | | | | | |
| Test Sample Positioning | ±2.9% | N | 1 | 1 | 1 | ±2.9% | ±2.9% | 145 |
| Device Holder | ±3.6% | N | 1 | 1 | 1 | ±3.6% | ±3.6% | 5 |
| Power Drift | ±5.0% | R | √3 | 1 | 1 | ±2.9% | ±2.9% | ∞ |
| Power Scaling | ±0.0% | R | √3 | 1 | 1 | ±0.0% | ±0.0% | ∞ |
| Phantom and Setup | | | | | | | | |
| Phantom Uncertainty | ±4.5% | R | √3 | 1 | 1 | ±2.4% | ±2.4% | ∞ |
| SAR correction | ±1.9% | R | √3 | 1 | 0.84 | ±1.9% | ±1.9% | ∞ |
| Liquid Conductivity (target) | ±5.0% | R | √3 | 0.64 | 0.43 | ±1.8% | ±1.2% | ∞ |
| Liquid Conductivity (mea.)DAK | ±2.5% | R | √3 | 0.64 | 0.43 | ±0.9% | ±0.6% | ∞ |
| Liquid Permittivity (target) | ±5.0% | R | √3 | 0.6 | 0.49 | ±1.7% | ±1.4% | ∞ |
| Liquid Permittivity(meas.)DAK | ±2.5% | R | √3 | 0.6 | 0.49 | ±0.9% | ±0.7% | ∞ |
| Combined Std. Uncertainty | | | | | | ±11.0% | ±10.9% | 387 |
| Expanded STD Uncertainty | | | | | | ±22.1% | ±21.8% | |

4. MEASUREMENT EQUIPMENT LIST

| Item | Type | Manufacturer | Model No. | Serial No. | Cal. Date | Cal. Interval |
|------|-----------------------------|--------------|------------|-----------------|--------------|---------------|
| 1. | Stäubli Robot TX90 XL | Stäubli | TX90 | F12/5K9SA1/A101 | N/A | N/A |
| 2. | Controller | SPEAG | CS8c | N/A | N/A | N/A |
| 3. | SAM Twin Phantom | SPEAG | N/A | 1706 | N/A | N/A |
| 4. | ELI5 Phantom | SPEAG | N/A | 1170 | N/A | N/A |
| 5. | Device Holder | SPEAG | N/A | N/A | N/A | N/A |
| 6. | Data Acquisition Electronic | SPEAG | DAE4 | 714 | 2019. 06. 20 | 1 Year |
| 7. | E-Field Probe | SPEAG | EX3DV4 | 3855 | 2019. 09. 26 | 1 Year |
| 8. | SAR Software | SPEAG | DASY52 | V.52.8.8.1222 | N/A | N/A |
| 9. | ENA Network Analyzer | Agilent | E5071C-285 | MY46215502 | 2019. 04. 15 | 1 Year |
| 10. | Signal Generator | Aglient | N5181A | MY50143917 | 2019. 09. 11 | 1 Year |
| 11. | Power Meter | Aglient | ML2487A | MY52180007 | 2019. 09. 11 | 1 Year |
| 12. | Power Sensor | Aglient | N8481 | MY52080006 | 2019. 09. 11 | 1 Year |
| 13. | Dipole Antenna | SPEAG | D2450V2 | 888 | 2019. 09. 27 | 3 Years |
| 14. | Dipole Antenna | SPEAG | D5GHzV2 | 1124 | 2019. 09. 27 | 3 Years |

5. SAR MEASUREMENT SYSTEM

5.1. Definition of Specific Absorption Rate (SAR)

SAR is related to the rate at which energy is absorbed per unit mass in an object exposed to a radio field. The SAR distribution in a biological body is complicated and is usually carried out by experimental techniques or numerical modeling. The standard recommends limits for two tiers of groups, occupational/controlled and general population/uncontrolled, based on a person's awareness and ability to exercise control over his or her exposure. In general, occupational/controlled exposure limits are higher than the limits for general population/uncontrolled.

The SAR definition is the time derivative (rate) of the incremental energy (dW) absorbed by (dissipated in) an incremental mass (dm) contained in a volume element (dv) of a given density (ρ). The equation description is as below:

$$\text{SAR} = \frac{d}{dt} \left(\frac{dW}{dm} \right) = \frac{d}{dt} \left(\frac{dW}{\rho dv} \right)$$

SAR is expressed in units of Watts per kilogram (W/kg)

SAR measurement can be related to the electrical field in the tissue by

$$\text{SAR} = \frac{\sigma |E|^2}{\rho}$$

Where: σ is the conductivity of the tissue, ρ is the mass density of the tissue and E is the RMS electrical field strength.

5.2. SPEAG DASY System

DASY system consists of high precision robot, probe alignment sensor, phantom, robot controller, controlled measurement server and near-field probe. The robot includes six axes that can move to the precision position of the DASY5 software defined. The DASY software can define the area that is detected by the probe. The robot is connected to controlled box. Controlled measurement server is connected to the controlled robot box. The DAE includes amplifier, signal multiplexing, AD converter, offset measurement and surface detection. It is connected to the Electro-optical coupler (ECO). The ECO performs the conversion from the optical into digital electric signal of the DAE and transfers data to the PC.

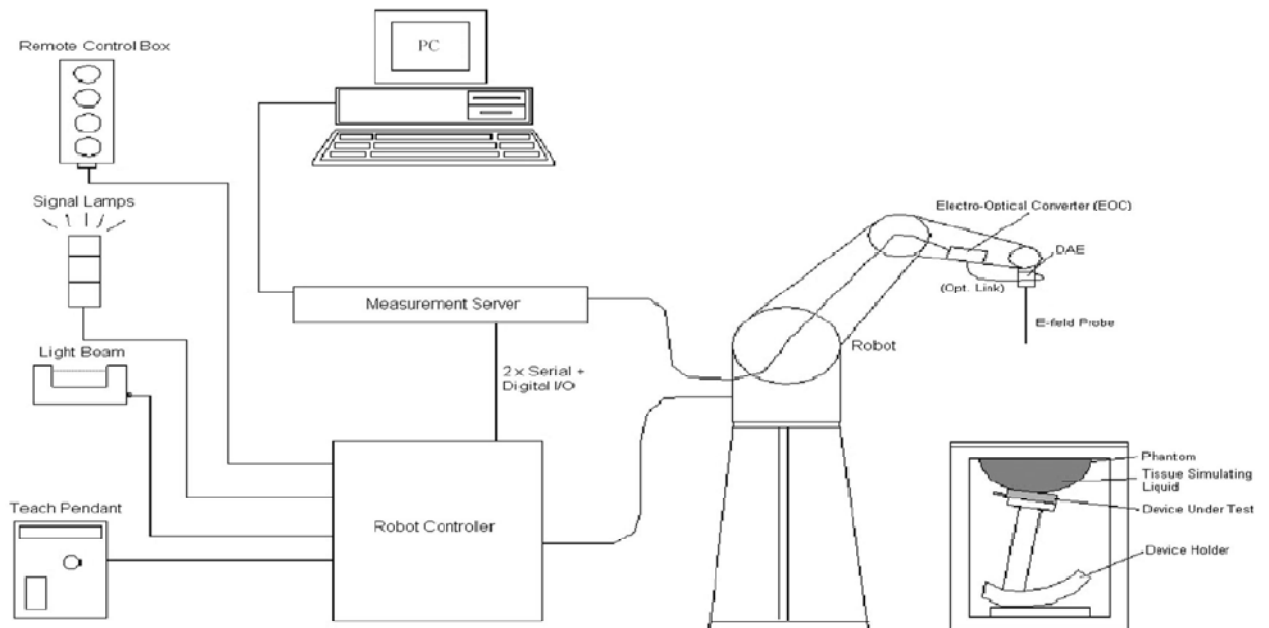
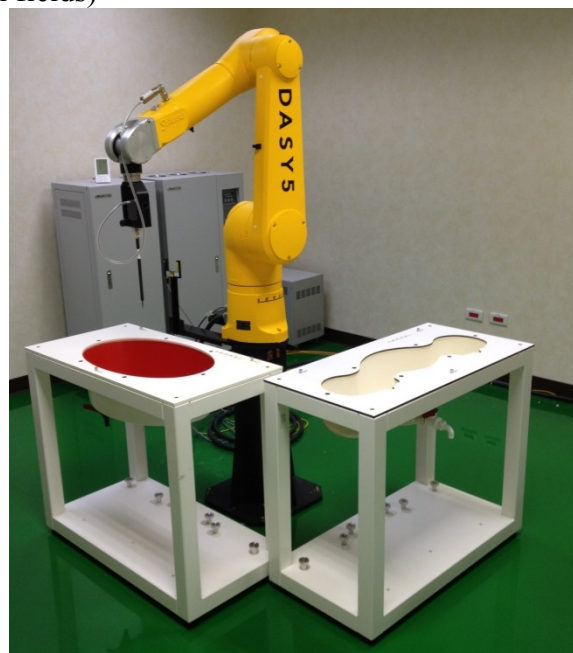

Fig-3.1 DASY System Setup

5.2.1. Robot

The DASY system uses the high precision robots from Stäubli SA (France). For the 6-axis controller system, the robot controller version (DASY5: CS8c) from Stäubli is used. The Stäubli robot series have many features that are important for our application:

- High precision (repeatability ± 0.035 mm)
- High reliability (industrial design)
- Jerk-free straight movements
- Low ELF interference (the closed metallic construction shields against motor control fields)



5.2.2. Probes

| | | |
|--------------|---|---|
| Model | Ex3DV4 |  |
| Construction | Symmetrical design with triangular core Built-in shielding against static charges PEEK enclosure material (resistant to organic solvents, e.g., DGBE) | |
| Frequency | 10 MHz to 6 GHz Linearity: ± 0.2 dB | |
| Directivity | ± 0.3 dB in HSL (rotation around probe axis) ± 0.5 dB in tissue material (rotation normal to probe axis) | |
| DynamicRange | 10 μ W/g to 100 mW/g Linearity: ± 0.2 dB (noise: typically < 1 μ W/g) | |
| Dimensions | Overall length: 337 mm (Tip: 20 mm) Tip diameter: 2.5 mm (Body: 12 mm) Typical distance from probe tip to dipole centers: 1 mm | |

5.2.3. Data Acquisition Electronics (DAE)

| | | |
|----------------------|--|---|
| Model | DAE4 |  |
| Construction | Signal amplifier, multiplexer, A/D converter and control logic. Serial optical link for communication with DASY4/5 embedded system (fully remote controlled). Two step probe touch detector for mechanical surface detection and emergency robot stop. | |
| MeasurementRange | -100 to +300 mV (16 bit resolution and two range settings: 4mV, 400mV) | |
| Input Offset Voltage | $< 5\mu$ V (with auto zero) | |
| Input Bias Current | < 50 fA | |
| Dimensions | 60 x 60 x 68 mm | |

5.2.4. Phantom

| | | |
|-----------------|---|---|
| Model | Twin SAM |  |
| Construction | The shell corresponds to the specifications of the Specific Anthropomorphic Mannequin (SAM) phantom defined in IEEE 1528 and IEC 62209-1. It enables the dosimetric evaluation of left and right hand phone usage as well as body mounted usage at the flat phantom region. A cover prevents evaporation of the liquid. Reference markings on the phantom allow the complete setup of all predefined phantom positions and measurement grids by teaching three points with the robot. | |
| Material | Vinylester, glass fiber reinforced (VE-GF) | |
| Shell Thickness | 2 ± 0.2 mm (6 ± 0.2 mm at ear point) | |
| Dimensions | Length: 1000 mm Width: 500 mm Height: adjustable feet | |
| Filling Volume | approx. 25 liters | |

| | | |
|-----------------|---|---|
| Model | ELI |  |
| Construction | Phantom for compliance testing of handheld and body-mounted wireless devices in the frequency range of 30 MHz to 6 GHz. ELI is fully compatible with the IEC 62209-2 standard and all known tissue simulating liquids. ELI has been optimized regarding its performance and can be integrated into our standard phantom tables. A cover prevents evaporation of the liquid. Reference markings on the phantom allow installation of the complete setup, including all predefined phantom positions and measurement grids, by teaching three points. The phantom is compatible with all SPEAG dosimetric probes and dipoles. | |
| Material | Vinylester, glass fiber reinforced (VE-GF) | |
| Shell Thickness | 2.0 ± 0.2 mm (bottom plate) | |
| Dimensions | Major axis: 600 mm Minor axis: 400 mm | |
| Filling Volume | approx. 30 liters | |

5.2.5. Device Holder

| | | |
|--------------|---|---|
| Model | Mounting Device |  |
| Construction | In combination with the Twin SAM Phantom or ELI4, the Mounting Device enables the rotation of the mounted transmitter device in spherical coordinates. Rotation point is the ear opening point. Transmitter devices can be easily and accurately positioned according to IEC, IEEE, FCC or other specifications. The device holder can be locked for positioning at different phantom sections (left head, right head, flat). | |
| Material | POM | |

| | | |
|--------------|---|--|
| Model | Laptop Extensions Kit |  |
| Construction | Simple but effective and easy-to-use extension for Mounting Device that facilitates the testing of larger devices according to IEC 62209-2 (e.g., laptops, cameras, etc.). It is lightweight and fits easily on the upper part of the Mounting Device in place of the phone positioner. | |
| Material | POM, Acrylic glass, Foam | |

5.2.6. Reference Dipole

| | | |
|------------------|--|---|
| Model | System Validation Dipoles |  |
| Construction | Symmetrical dipole with 1/4 balun. Enables measurement of feed point impedance with NWA. Matched for use near flat phantoms filled with tissue simulating solutions. | |
| Frequency | 750 MHz to 5800 MHz | |
| Return Loss | > 20 dB | |
| Power Capability | > 100 W (f < 1GHz), > 40 W (f > 1GHz) | |

5.2.7. Tissue Simulating Liquids

For SAR measurement of the field distribution inside the phantom, the phantom must be filled with homogeneous tissue simulating liquid to a depth of at least 15 cm. For head SAR testing, the liquid height from the ear reference point (ERP) of the phantom to the liquid top surface is larger than 15 cm. For body SAR testing, the liquid height from the center of the flat phantom to the liquid top surface is larger than 15 cm. The nominal dielectric values of the tissue simulating liquids in the phantom and the tolerance of 5% are listed in Table-5.1.

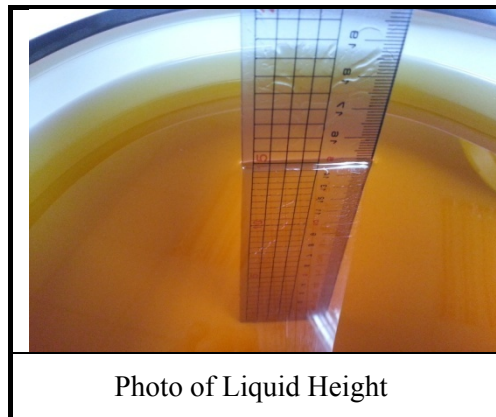

The dielectric properties of the head tissue simulating liquids are defined in IEEE 1528 and FCC OET 65 Supplement C Appendix C. For the body tissue simulating liquids, the dielectric properties are defined in FCC OET 65 Supplement C Appendix C. The dielectric properties of the tissue simulating liquids were verified prior to the SAR evaluation using an Agilent 85070D Dielectric Probe Kit and an Agilent Network Analyzer.

Table-5.1 Targets of Tissue Simulating Liquid

| Target Frequency [MHz] | Target Permittivity (ϵ_r) | Range of $\pm 5\%$ | Target Conductivity σ [s/m] | Range of $\pm 5\%$ |
|------------------------|--------------------------------------|--------------------|------------------------------------|--------------------|
| For Head | | | | |
| 750 | 41.9 | 39.8 ~ 44.0 | 0.89 | 0.85 ~ 0.93 |
| 835 | 41.5 | 39.4 ~ 43.6 | 0.90 | 0.86 ~ 0.95 |
| 900 | 41.5 | 39.4 ~ 43.6 | 0.97 | 0.92 ~ 1.02 |
| 1450 | 40.5 | 38.5 ~ 42.5 | 1.20 | 1.14 ~ 1.26 |
| 1640 | 40.3 | 38.3 ~ 42.3 | 1.29 | 1.23 ~ 1.35 |
| 1750 | 40.1 | 38.1 ~ 42.1 | 1.37 | 1.30 ~ 1.44 |
| 1800 | 40.0 | 38.0 ~ 42.0 | 1.40 | 1.33 ~ 1.47 |
| 1900 | 40.0 | 38.0 ~ 42.0 | 1.40 | 1.33 ~ 1.47 |
| 2000 | 40.0 | 38.0 ~ 42.0 | 1.40 | 1.33 ~ 1.47 |
| 2300 | 39.5 | 37.5 ~ 41.5 | 1.67 | 1.59 ~ 1.75 |
| 2450 | 39.2 | 37.2 ~ 41.2 | 1.80 | 1.71 ~ 1.89 |
| 2600 | 39.0 | 37.1 ~ 41.0 | 1.96 | 1.86 ~ 2.06 |
| 3500 | 37.9 | 36.0 ~ 39.8 | 2.91 | 2.76 ~ 3.06 |
| 5200 | 36.0 | 34.2 ~ 37.8 | 4.66 | 4.43 ~ 4.89 |
| 5300 | 35.9 | 34.1 ~ 37.7 | 4.76 | 4.52 ~ 5.00 |
| 5500 | 35.6 | 33.8 ~ 37.4 | 4.96 | 4.71 ~ 5.21 |
| 5600 | 35.5 | 33.7 ~ 37.3 | 5.07 | 4.82 ~ 5.32 |
| 5800 | 35.3 | 33.5 ~ 37.1 | 5.27 | 5.01 ~ 5.53 |
| For Body | | | | |
| 750 | 55.5 | 52.7 ~ 58.3 | 0.96 | 0.91 ~ 1.01 |
| 835 | 55.2 | 52.4 ~ 58.0 | 0.97 | 0.92 ~ 1.02 |
| 900 | 55.0 | 52.3 ~ 57.8 | 1.05 | 1.00 ~ 1.10 |
| 1450 | 54.0 | 51.3 ~ 56.7 | 1.30 | 1.24 ~ 1.37 |
| 1640 | 53.8 | 51.1 ~ 56.5 | 1.40 | 1.33 ~ 1.47 |
| 1750 | 53.4 | 50.7 ~ 56.1 | 1.49 | 1.42 ~ 1.56 |
| 1800 | 53.3 | 50.6 ~ 56.0 | 1.52 | 1.44 ~ 1.60 |
| 1900 | 53.3 | 50.6 ~ 56.0 | 1.52 | 1.44 ~ 1.60 |
| 2000 | 53.3 | 50.6 ~ 56.0 | 1.52 | 1.44 ~ 1.60 |
| 2300 | 52.9 | 50.3 ~ 55.5 | 1.81 | 1.72 ~ 1.90 |
| 2450 | 52.7 | 50.1 ~ 55.3 | 1.95 | 1.85 ~ 2.05 |
| 2600 | 52.5 | 49.9 ~ 55.1 | 2.16 | 2.05 ~ 2.27 |
| 3500 | 51.3 | 48.7 ~ 53.9 | 3.31 | 3.14 ~ 3.48 |
| 5200 | 49.0 | 46.6 ~ 51.5 | 5.30 | 5.04 ~ 5.57 |
| 5300 | 48.9 | 46.5 ~ 51.3 | 5.42 | 5.15 ~ 5.69 |
| 5500 | 48.6 | 46.2 ~ 51.0 | 5.65 | 5.37 ~ 5.93 |
| 5600 | 48.5 | 46.1 ~ 50.9 | 5.77 | 5.48 ~ 6.06 |
| 5800 | 48.2 | 45.8 ~ 50.6 | 6.00 | 5.70 ~ 6.30 |

Table-5.2 Recipes of Tissue Simulating Liquid

| Tissue Type | Bactericide | DGBE | HEC | NaCl | Sucrose | Triton X-100 | Water | Diethylene Glycol Mono-hexylether |
|-------------|-------------|------|-----|------|---------|--------------|-------|-----------------------------------|
| For Head | | | | | | | | |
| H750 | 0.2 | - | 0.2 | 1.5 | 56.0 | - | 42.1 | - |
| H835 | 0.2 | - | 0.2 | 1.5 | 57.0 | - | 41.1 | - |
| H900 | 0.2 | - | 0.2 | 1.4 | 58.0 | - | 40.2 | - |
| H1450 | - | 43.3 | - | 0.6 | - | - | 56.1 | - |
| H1640 | - | 45.8 | - | 0.5 | - | - | 53.7 | - |
| H1750 | - | 47.0 | - | 0.4 | - | - | 52.6 | - |
| H1800 | - | 44.5 | - | 0.3 | - | - | 55.2 | - |
| H1900 | - | 44.5 | - | 0.2 | - | - | 55.3 | - |
| H2000 | - | 44.5 | - | 0.1 | - | - | 55.4 | - |
| H2300 | - | 44.9 | - | 0.1 | - | - | 55.0 | - |
| H2450 | - | 45.0 | - | 0.1 | - | - | 54.9 | - |
| H2600 | - | 45.1 | - | 0.1 | - | - | 54.8 | - |
| H3500 | - | 8.0 | - | 0.2 | - | 20.0 | 71.8 | - |
| H5G | - | - | - | - | - | 17.2 | 65.5 | 17.3 |
| For Body | | | | | | | | |
| B750 | 0.2 | - | 0.2 | 0.8 | 48.8 | - | 50.0 | - |
| B835 | 0.2 | - | 0.2 | 0.9 | 48.5 | - | 50.2 | - |
| B900 | 0.2 | - | 0.2 | 0.9 | 48.2 | - | 50.5 | - |
| B1450 | - | 34.0 | - | 0.3 | - | - | 65.7 | - |
| B1640 | - | 32.5 | - | 0.3 | - | - | 67.2 | - |
| B1750 | - | 31.0 | - | 0.2 | - | - | 68.8 | - |
| B1800 | - | 29.5 | - | 0.4 | - | - | 70.1 | - |
| B1900 | - | 29.5 | - | 0.3 | - | - | 70.2 | - |
| B2000 | - | 30.0 | - | 0.2 | - | - | 69.8 | - |
| B2300 | - | 31.0 | - | 0.1 | - | - | 68.9 | - |
| B2450 | - | 31.4 | - | 0.1 | - | - | 68.5 | - |
| B2600 | - | 31.8 | - | 0.1 | - | - | 68.1 | - |
| B3500 | - | 28.8 | - | 0.1 | - | - | 71.1 | - |
| B5G | - | - | - | - | - | 10.7 | 78.6 | 10.7 |

5.3. SAR System Verification

The system check verifies that the system operates within its specifications. It is performed daily or before every SAR measurement. The system check uses normal SAR measurements in the flat section of the phantom with a matched dipole at a specified distance. The system verification setup is shown as below.

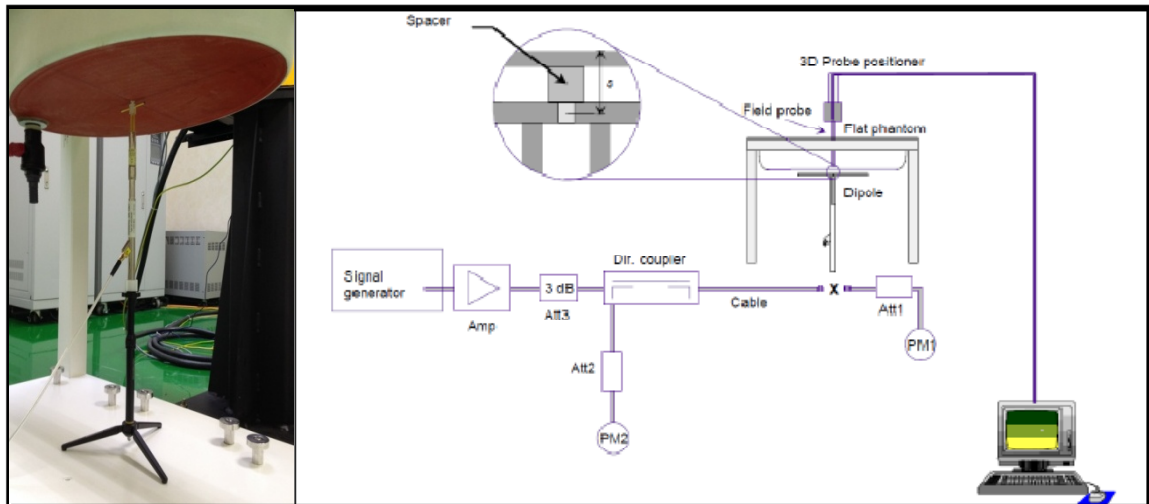

The validation dipole is placed beneath the flat phantom with the specific spacer in place. The distance spacer is touch the phantom surface with a light pressure at the reference marking and be oriented parallel to the long side of the phantom. The power meter PM1 measures the forward power at the location of the system check dipole connector. The signal generator is adjusted for the desired forward power (250 mW is used for 700 MHz to 3 GHz, 100 mW is used for 3.5 GHz to 6 GHz) at the dipole connector and the power meter PM2 is read at that level. After connecting the cable to the dipole, the signal generator is readjusted for the same reading at power meter PM2.

After system check testing, the SAR result will be normalized to 1W forward input power and compared with the reference SAR value derived from validation dipole certificate report. The deviation of system check should be within 10 %.

5.3.1. SAR System Verification Result

| System Performance Check at WLAN | | | | |
|--|------------------|------------------|------------------|-------------------|
| Dipole Kit: D2450V2(Body) | | | | |
| Frequency [MHz] | Description | SAR [w/kg] 1g | SAR [w/kg] 10g | Liquid Temp. [°C] |
| 2450MHz | Reference result | 51.2 | 24.0 | N/A |
| | ± 10% window | 46.080 to 56.320 | 21.600 to 26.400 | |
| | 2019. 12. 23 | 55.6 | 25.36 | 23.2 |
| Note: All SAR values are normalized to 1W forward power. | | | | |

| System Performance Check at WLAN | | | | |
|--|------------------|------------------|------------------|-------------------|
| Dipole Kit: D5GHzV2 (Body) | | | | |
| Frequency [MHz] | Description | SAR [w/kg] 1g | SAR [w/kg] 10g | Liquid Temp. [°C] |
| 5300MHz | Reference result | 76.9 | 21.15 | N/A |
| | ± 10% window | 69.210 to 84.590 | 19.035 to 23.265 | |
| | 2019. 12. 18 | 82.6 | 22.9 | 23.5 |
| | 2020. 01. 17 | 82.1 | 23.4 | 23.2 |
| Note: All SAR values are normalized to 1W forward power. | | | | |

| System Performance Check at WLAN | | | | |
|--|------------------|------------------|------------------|-------------------|
| Dipole Kit: D5GHzV2 (Body) | | | | |
| Frequency [MHz] | Description | SAR [w/kg] 1g | SAR [w/kg] 10g | Liquid Temp. [°C] |
| 5600MHz | Reference result | 80.6 | 22.4 | N/A |
| | ± 10% window | 72.540 to 88.660 | 20.160 to 24.640 | |
| | 2019. 12. 19 | 87.6 | 24.0 | 23.5 |
| | 2020. 01. 17 | 87.7 | 24.6 | 23.2 |
| Note: All SAR values are normalized to 1W forward power. | | | | |

| System Performance Check at WLAN | | | | |
|----------------------------------|----------------------------------|--------------------------|--------------------------|-------------------|
| Dipole Kit: D5GHzV2 (Body) | | | | |
| Frequency [MHz] | Description | SAR [w/kg] 1g | SAR [w/kg] 10g | Liquid Temp. [°C] |
| 5800MHz | Reference result ± 10% window | 77.1 69.390 to 84.810 | 21.2 19.080 to 23.320 | N/A |
| | 2019. 12. 20 | 84.0 | 22.9 | 23.5 |
| | 2020. 01. 17 | 83.6 | 18.9 | 23.2 |

Note: All SAR values are normalized to 1W forward power.

5.3.2. SAR System Check Data

Date: 12/23/2019

Test Laboratory: Audix_SAR Lab

System Check_B2450

DUT: D2450V2 - SN888; Type: D2450V2; Serial: SN888

Communication System: UID 0, CW (0); Frequency: 2450 MHz; Duty Cycle: 1:1

Medium parameters used: $f = 2450$ MHz; $\sigma = 1.985$ S/m; $\epsilon_r = 51.431$; $\rho = 1000$ kg/m³

Phantom section: Flat Section

DASY Configuration:

- Probe: EX3DV4 - SN3855; ConvF(7.63, 7.63, 7.63); Calibrated: 9/26/2019;
- Sensor-Surface: 2mm (Mechanical Surface Detection), $z = 1.0, 31.0$
- Electronics: DAE4 Sn1337; Calibrated: 9/18/2019
- Phantom: ELI v5.0; Type: QDOVA002AA; Serial: TP:1170
- DASY52 52.8.8(1258); SEMCAD X 14.6.10(7373)

P=100mW/Area Scan (8x8x1): Measurement grid: $dx=10$ mm, $dy=10$ mm

Maximum value of SAR (measured) = 20.2 W/kg

P=100mW/Zoom Scan (5x5x7)/Cube 0: Measurement grid: $dx=8$ mm, $dy=8$ mm, $dz=5$ mm

Reference Value = 76.28 V/m; Power Drift = 0.04 dB

Peak SAR (extrapolated) = 31.2 W/kg

SAR(1 g) = 13.9 W/kg; SAR(10 g) = 6.34 W/kg

Maximum value of SAR (measured) = 16.3 W/kg

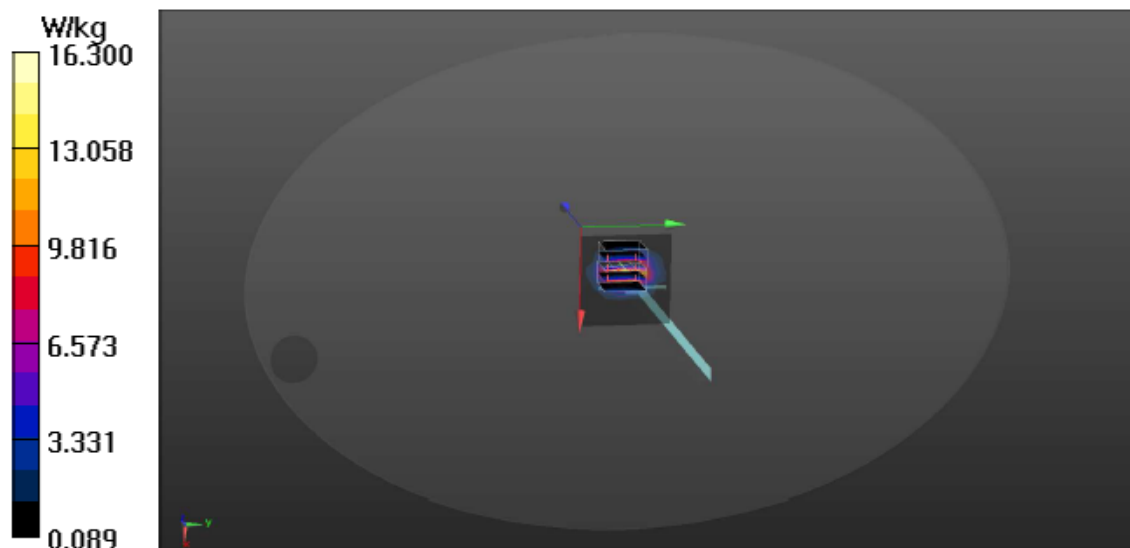

Date: 12/18/2019

Test Laboratory: Audix_SAR Lab

System Check_B5300**DUT: D5GHzV2 - SN1124; Type: D5GHzV2; Serial: SN1124**

Communication System: UID 0, CW (0); Frequency: 5300 MHz; Duty Cycle: 1:1
Medium parameters used: $f = 5300$ MHz; $\sigma = 5.564$ S/m; $\epsilon_r = 47.528$; $\rho = 1000$ kg/m³

Phantom section: Flat Section

DASY Configuration:

- Probe: EX3DV4 - SN3855; ConvF(4.44, 4.44, 4.44); Calibrated: 9/26/2019;
- Sensor-Surface: 2mm (Mechanical Surface Detection), $z = 1.0, 31.0$
- Electronics: DAE4 Sn1337; Calibrated: 9/18/2019
- Phantom: ELI v5.0; Type: QDOVA002AA; Serial: TP:1170
- DASY52 52.8.8(1258); SEMCAD X 14.6.10(7373)

P=100mW/Area Scan (7x7x1): Measurement grid: dx=10mm, dy=10mm
Maximum value of SAR (measured) = 14.3 W/kg

P=100mW/Zoom Scan (7x7x9)/Cube 0: Measurement grid: dx=4mm, dy=4mm, dz=2.5mm
Reference Value = 33.82 V/m; Power Drift = 0.20 dB
Peak SAR (extrapolated) = 32.5 W/kg
SAR(1 g) = 8.26 W/kg; SAR(10 g) = 2.29 W/kg
Maximum value of SAR (measured) = 15.3 W/kg

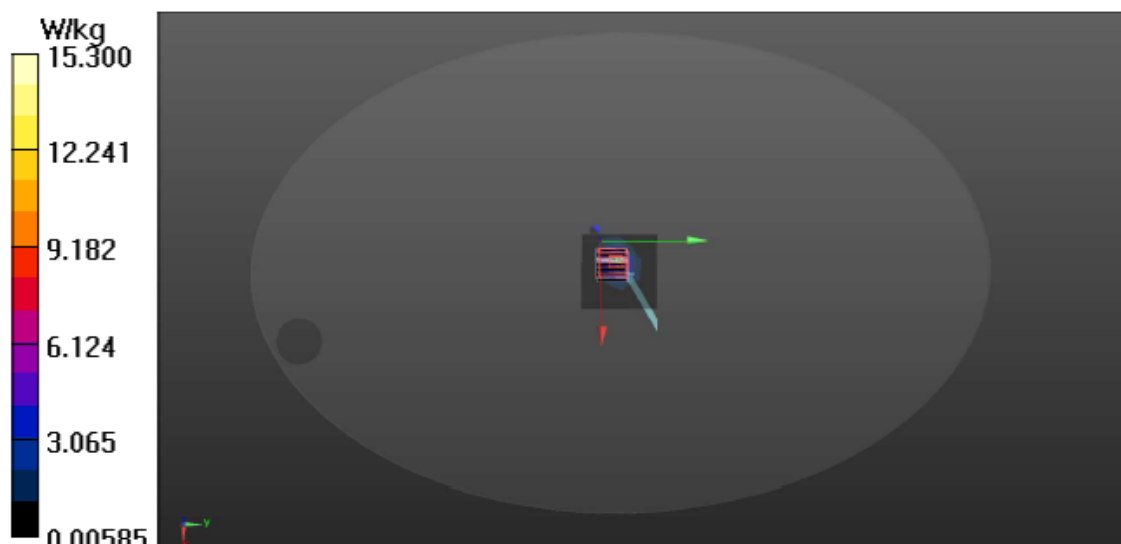

Date: 1/17/2020

Test Laboratory: Audix_SAR Lab

System Check_B5300**DUT: D5GHzV2 - SN1124; Type: D5GHzV2; Serial: SN1124**

Communication System: UID 0, CW (0); Frequency: 5300 MHz; Duty Cycle: 1:1

Medium parameters used: $f = 5300$ MHz; $\sigma = 5.575$ S/m; $\epsilon_r = 47.545$; $\rho = 1000$ kg/m³

Phantom section: Flat Section

DASY Configuration:

- Probe: EX3DV4 - SN3855; ConvF(4.44, 4.44, 4.44); Calibrated: 9/26/2019;
- Sensor-Surface: 2mm (Mechanical Surface Detection), $z = 1.0, 31.0$
- Electronics: DAE4 Sn1337; Calibrated: 9/18/2019
- Phantom: ELI v5.0; Type: QDOVA002AA; Serial: TP:1170
- DASY52 52.8.8(1258); SEMCAD X 14.6.10(7373)

P=100mW/Area Scan (7x7x1): Measurement grid: $dx=10$ mm, $dy=10$ mm

Maximum value of SAR (measured) = 17.2 W/kg

P=100mW/Zoom Scan (7x7x9)/Cube 0: Measurement grid: $dx=4$ mm, $dy=4$ mm, $dz=2.5$ mm

Reference Value = 35.27 V/m; Power Drift = 0.22 dB

Peak SAR (extrapolated) = 37.3 W/kg

SAR(1 g) = 8.21 W/kg; SAR(10 g) = 2.34 W/kg

Maximum value of SAR (measured) = 16.7 W/kg

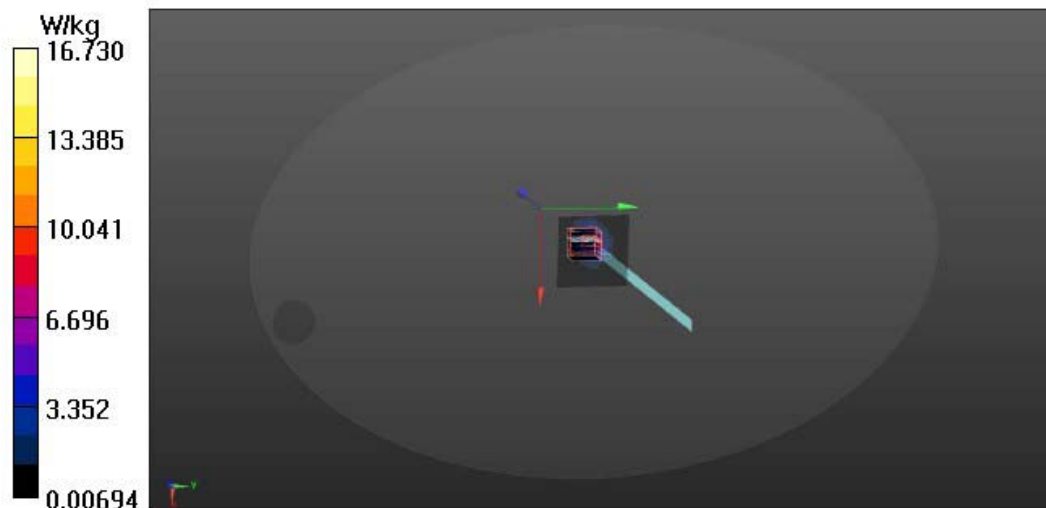

Date: 12/19/2019

Test Laboratory: Audix_SAR Lab

System Check_B5600**DUT: D5GHzV2 - SN1124; Type: D5GHzV2; Serial: SN1124**

Communication System: UID 0, CW (0); Frequency: 5600 MHz; Duty Cycle: 1:1

Medium parameters used: $f = 5600$ MHz; $\sigma = 5.982$ S/m; $\epsilon_r = 46.911$; $\rho = 1000$ kg/m³

Phantom section: Flat Section

DASY Configuration:

- Probe: EX3DV4 - SN3855; ConvF(4.12, 4.12, 4.12); Calibrated: 9/26/2019;
- Sensor-Surface: 2mm (Mechanical Surface Detection), $z = 1.0, 31.0$
- Electronics: DAE4 Sn1337; Calibrated: 9/18/2019
- Phantom: ELI v5.0; Type: QDOVA002AA; Serial: TP:1170
- DASY52 52.8.8(1258); SEMCAD X 14.6.10(7373)

P=100mW/Area Scan (7x7x1): Measurement grid: dx=10mm, dy=10mm

Maximum value of SAR (measured) = 13.1 W/kg

P=100mW/Zoom Scan (7x7x9)/Cube 0: Measurement grid: dx=4mm, dy=4mm, dz=2.5mm

Reference Value = 33.24 V/m; Power Drift = 0.73 dB

Peak SAR (extrapolated) = 35.4 W/kg

SAR(1 g) = 8.76 W/kg; SAR(10 g) = 2.4 W/kg

Maximum value of SAR (measured) = 18.3 W/kg

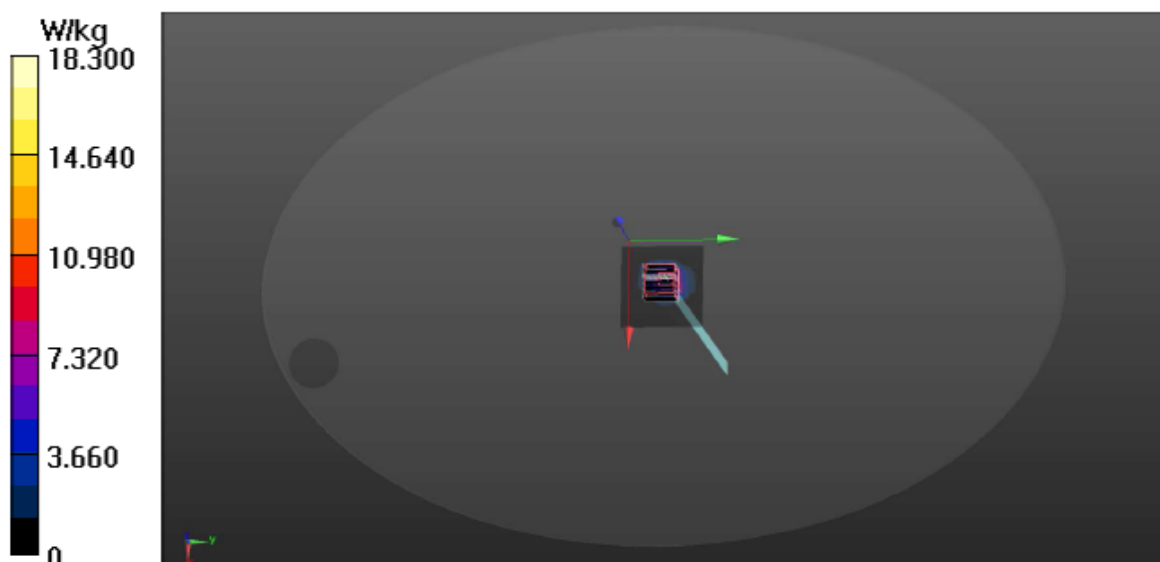

Date: 1/17/2020

Test Laboratory: Audix_SAR Lab

System Check_B5600**DUT: D5GHzV2 - SN1124; Type: D5GHzV2; Serial: SN1124**

Communication System: UID 0, CW (0); Frequency: 5600 MHz; Duty Cycle: 1:1
Medium parameters used: $f = 5600$ MHz, $\sigma = 5.992$ S/m, $\epsilon_r = 46.927$; $\rho = 1000$ kg/m³
Phantom section: Flat Section

DASY Configuration:

- Probe: EX3DV4 - SN3855; ConvF(4.12, 4.12, 4.12); Calibrated: 9/26/2019;
- Sensor-Surface: 2mm (Mechanical Surface Detection), $z = 1.0, 31.0$
- Electronics: DAE4 Sn1337; Calibrated: 9/18/2019
- Phantom: ELI v5.0; Type: QDOVA002AA; Serial: TP:1170
- DASY52 52.8.8(1258); SEMCAD X 14.6.10(7373)

P=100mW/Area Scan (7x7x1): Measurement grid: $dx=10$ mm, $dy=10$ mm
Maximum value of SAR (measured) = 13.1 W/kg

P=100mW/Zoom Scan (7x7x9)/Cube 0: Measurement grid: $dx=4$ mm, $dy=4$ mm, $dz=2.5$ mm
Reference Value = 34.17 V/m; Power Drift = 0.27 dB
Peak SAR (extrapolated) = 33.4 W/kg
SAR(1 g) = 8.77 W/kg; SAR(10 g) = 2.46 W/kg
Maximum value of SAR (measured) = 18.3 W/kg

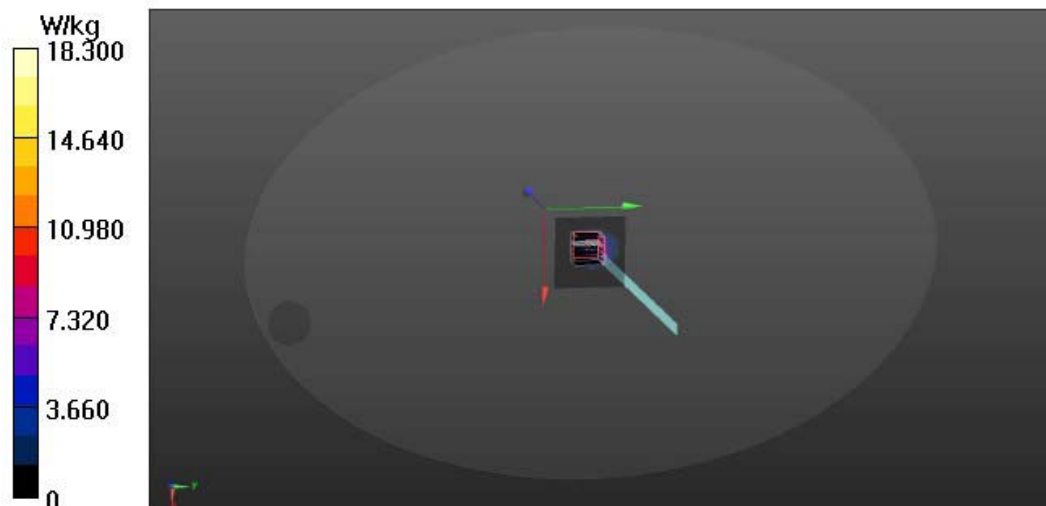

Date: 12/20/2019

Test Laboratory: Audix_SAR Lab

System Check_B5800**DUT: D5GHzV2 - SN1124; Type: D5GHzV2; Serial: SN1124**

Communication System: UID 0, CW (0); Frequency: 5800 MHz; Duty Cycle: 1:1
Medium parameters used: $f = 5800$ MHz; $\sigma = 6.258$ S/m; $\epsilon_r = 46.53$; $\rho = 1000$ kg/m³
Phantom section: Flat Section

DASY Configuration:

- Probe: EX3DV4 - SN3855; ConvF(4.18, 4.18, 4.18); Calibrated: 9/26/2019;
- Sensor-Surface: 2mm (Mechanical Surface Detection), $z = 1.0, 31.0$
- Electronics: DAE4 Sn1337; Calibrated: 9/18/2019
- Phantom: ELI v5.0; Type: QDOVA002AA; Serial: TP:1170
- DASY52 52.8.8(1258); SEMCAD X 14.6.10(7373)

P=100mW/Area Scan (7x7x1): Measurement grid: dx=10mm, dy=10mm
Maximum value of SAR (measured) = 13.8 W/kg

P=100mW/Zoom Scan (7x7x9)/Cube 0: Measurement grid: dx=4mm, dy=4mm, dz=2.5mm
Reference Value = 33.94 V/m; Power Drift = 0.64 dB
Peak SAR (extrapolated) = 37.1 W/kg
SAR(1 g) = 8.40 W/kg; SAR(10 g) = 2.29 W/kg
Maximum value of SAR (measured) = 18.8 W/kg

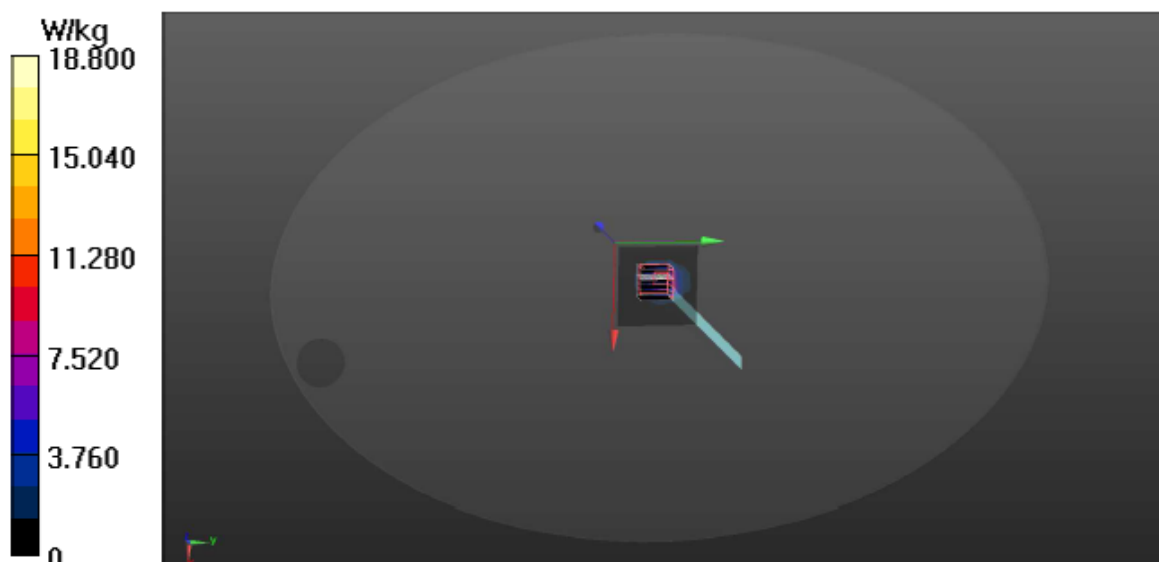

Date: 10/17/2020

Test Laboratory: Audix_SAR Lab

System Check_B5800**DUT: D5GHzV2 - SN1124; Type: D5GHzV2; Serial: SN1124**

Communication System: UID 0, CW (0); Frequency: 5800 MHz; Duty Cycle: 1:1

Medium parameters used: $f = 5800$ MHz, $\sigma = 6.269$ S/m, $\epsilon_r = 46.543$; $\rho = 1000$ kg/m³

Phantom section: Flat Section

DASY Configuration:

- Probe: EX3DV4 - SN3855; ConvF(4.18, 4.18, 4.18); Calibrated: 9/26/2019;
- Sensor-Surface: 2mm (Mechanical Surface Detection), $z = 1.0, 31.0$
- Electronics: DAE4 Sn1337; Calibrated: 9/18/2019
- Phantom: ELI v5.0; Type: QDOVA002AA; Serial: TP:1170
- DASY52 52.8.8(1258); SEMCAD X 14.6.10(7373)

P=100mW/Area Scan (7x7x1): Measurement grid: $dx=10$ mm, $dy=10$ mm

Maximum value of SAR (measured) = 13.6 W/kg

P=100mW/Zoom Scan (7x7x9)/Cube 0: Measurement grid: $dx=4$ mm, $dy=4$ mm, $dz=2.5$ mm

Reference Value = 35.27 V/m; Power Drift = 0.74 dB

Peak SAR (extrapolated) = 36.7 W/kg

SAR(1 g) = 8.36 W/kg; SAR(10 g) = 2.27 W/kg

Maximum value of SAR (measured) = 18.9 W/kg

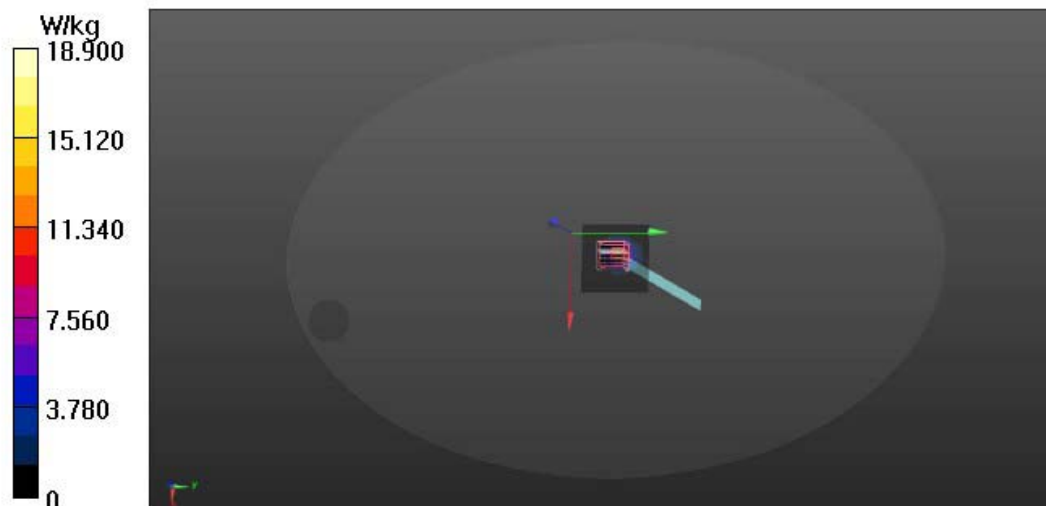

5.4. SAR Measurement Procedure

According to the SAR test standard, the recommended procedure for assessing the peak spatial-average SAR value consists of the following steps:

- (a) Power reference measurement
- (b) Area scan
- (c) Zoom scan
- (d) Power drift measurement

The SAR measurement procedures for each of test conditions are as follows:

- (a) Make EUT to transmit maximum output power
- (b) Measure conducted output power through RF cable
- (c) Place the EUT in the specific position of phantom
- (d) Perform SAR testing steps on the DASY system
- (e) Record the SAR value

5.4.1. Area & Zoom Scan Procedure

First Area Scan is used to locate the approximate location(s) of the local peak SAR value(s). The measurement grid within an Area Scan is defined by the grid extent, grid step size and grid offset. Next, in order to determine the EM field distribution in a three-dimensional spatial extension, Zoom Scan is required. The Zoom Scan is performed around the highest E-field value to determine the averaged SAR-distribution over 10 g. According to KDB 865664D01v01r03, the resolution for Area and Zoom scan is specified in the table below.

| Items | <= 2 GHz | 2-3 GHz | 3-4 GHz | 4-5 GHz | 5-6 GHz |
|---------------------------------------|----------|---------|---------|---------|---------|
| Area Scan ($\Delta x, \Delta y$) | <= 15mm | <= 12mm | <= 12mm | <= 10mm | <= 10mm |
| Zoom Scan ($\Delta x, \Delta y$) | <= 8mm | <= 5mm | <= 5mm | <= 4mm | <= 4mm |
| Zoom Scan (Δz) | <= 5mm | <= 5mm | <= 4mm | <= 3mm | <= 2mm |
| Zoom Scan Volume | >= 30mm | >= 30mm | >= 28mm | >= 25mm | >= 22mm |

Note:

When zoom scan is required and report SAR is <= 1.4 W/kg, the zoom scan resolution of $\Delta x / \Delta y$ (2-3GHz: <= 8 mm, 3-4GHz: <= 7 mm, 4-6GHz: <= 5 mm) may be applied.

5.4.2. Volume Scan Procedure

The volume scan is used for assess overlapping SAR distributions for antennas transmitting in different frequency bands. It is equivalent to an oversized zoom scan used in standalone measurements. The measurement volume will be used to enclose all the simultaneous transmitting antennas. For antennas transmitting simultaneously in different frequency bands, the volume scan is measured separately in each frequency band. In order to sum correctly to compute the 1g aggregate SAR, the EUT remain in the same test position for all measurements and all volume scan use the same spatial resolution and grid spacing. When all volume scan were completed, the software, SEMCAD postprocessor can combine and subsequently superpose these measurement data to calculating the multiband SAR.

5.4.3. Power Drift Monitoring

All SAR testing is under the EUT install full charged battery and transmit maximum output power. In DASY measurement software, the power reference measurement and power drift measurement procedures are used for monitoring the power drift of EUT during SAR test. Both these procedures measure the field at a specified reference position before and after the SAR testing. The software will calculate the field difference in dB. If the power drift more than 5%, the SAR will be retested.

5.4.4. Spatial Peak SAR Evaluation

The procedure for spatial peak SAR evaluation has been implemented according to the test standard. It can be conducted for 1g and 10g, as well as for user-specific masses. The DASY software includes all numerical procedures necessary to evaluate the spatial peak SAR value.

The base for the evaluation is a "cube" measurement. The measured volume must include the 1g and 10g cubes with the highest averaged SAR values. For that purpose, the center of the measured volume is aligned to the interpolated peak SAR value of a previously performed area scan.

The entire evaluation of the spatial peak values is performed within the post-processing engine (SEMCAD). The system always gives the maximum values for the 1g and 10g cubes. The algorithm to find the cube with highest averaged SAR is divided into the following stages:

- (a) Extraction of the measured data (grid and values) from the Zoom Scan
- (b) Calculation of the SAR value at every measurement point based on all stored data (A/D values and measurement parameters)
- (c) Generation of a high-resolution mesh within the measured volume
- (d) Interpolation of all measured values form the measurement grid to the high-resolution grid
- (e) Extrapolation of the entire 3-D field distribution to the phantom surface over the distance from sensor to surface
- (f) Calculation of the averaged SAR within masses of 1g and 10g

5.4.5. SAR Averaged Methods

In DASY, the interpolation and extrapolation are both based on the modified Quadratic Shepard's method. The interpolation scheme combines a least-square fitted function method and a weighted average method which are the two basic types of computational interpolation and approximation.

Extrapolation routines are used to obtain SAR values between the lowest measurement points and the inner phantom surface. The extrapolation distance is determined by the surface detection distance and the probe sensor offset. The uncertainty increases with the extrapolation distance. To keep the uncertainty within 1% for the 1 g and 10 g cubes, the extrapolation distance should not be larger than 5 mm.

6. SAR MEASUREMENT EVALUATION

6.1. EUT Configuration and Setting

Body-worn accessory exposure is typically related to voice mode operations when handsets are carried in body-worn accessories. The body-worn accessory procedures in KDB 447498 D01 are used to test for body-worn accessory SAR compliance, without a headset connected to it. This enables the test results for such configuration to be compatible with that required for hotspot mode when the body-worn accessory test separation distance is greater than or equal to that required for hotspot mode. When the reported SAR for a body-worn accessory, measured without a headset connected to the handset, is > 1.2 W/kg, the highest reported SAR configuration for that wireless mode and frequency band should be repeated for that body-worn accessory with a headset attached to the handset.

Body-worn accessories that do not contain metallic or conductive components may be tested according to worst-case exposure configurations, typically according to the smallest test separation distance required for the group of body-worn accessories with similar operating and exposure characteristics. All body-worn accessories containing metallic components are tested in conjunction with the host device.

Body-worn accessory SAR compliance is based on a single minimum test separation distance for all wireless and operating modes applicable to each body-worn accessory used by the host, and according to the relevant voice and/or data mode transmissions and operations. If a body-worn accessory supports voice only operations in its normal and expected use conditions, testing of data mode for body-worn compliance is not required.

A conservative minimum test separation distance for supporting off-the-shelf body-worn accessories that may be acquired by users of consumer handsets is used to test for body-worn accessory SAR compliance. This distance is determined by the handset manufacturer, according to the requirements of Supplement C 01-01. Devices that are designed to operate on the body of users using lanyards and straps, or without requiring additional body-worn accessories, will be tested using a conservative minimum test separation distance ≤ 5 mm to support compliance.

6.2. EUT Testing Position

The SAR testing required mode is listed as below.

| Antenna | Front Face | Rear Face | Top Side | Bottom Side | Left Side | Right Side |
|---------|------------|-----------|----------|-------------|-----------|------------|
| WLAN | | √ | | | | |

Note: Per KDB 447498 D01

- a) For 100 MHz to 6 GHz and test separation distances ≤ 50 mm, the 1-g and 10-g SAR test exclusion thresholds are determined by the following:
 $[(\text{max. power of channel, including tune-up tolerance, mW}) / (\text{min. test separation distance, mm})] \cdot [\sqrt{f(\text{GHz})}] \leq 3.0$ for 1-g SAR, and ≤ 7.5 for 10-g extremity SAR, where
 - $f(\text{GHz})$ is the RF channel transmit frequency in GHz
- b) For 100 MHz to 6 GHz and test separation distances > 50 mm, the 1-g and 10-g SAR test exclusion thresholds are determined by the following (also illustrated in Appendix B):³²
 - 1) $\{[\text{Power allowed at numeric threshold for 50 mm in step a)}] + [(\text{test separation distance} - 50 \text{ mm}) \cdot (f(\text{MHz})/150)]\}$ mW, for 100 MHz to 1500 MHz
 - 2) $\{[\text{Power allowed at numeric threshold for 50 mm in step a)}] + [(\text{test separation distance} - 50 \text{ mm}) \cdot 10]\}$ mW, for > 1500 MHz and ≤ 6 GHz

SAR test exclusion table distance is > 50 mm @ Left Side (AUX to edge)

| Frequency (GHz) | In Step 1 threshold Power (mW) | Distance between antenna and user (mm) | SAR Exclusion Threshold Power @ > 50 mm (mW) | EUT tune-up maximum power (mW) | SAR test |
|-----------------|--------------------------------|--|--|--------------------------------|----------|
| 2.442 | 95.9883 | 190 | 1495.9883 | 112.202 | No |
| 5.260 | 65.4031 | 190 | 1465.4031 | 100.000 | No |
| 5.580 | 63.5001 | 190 | 1463.5001 | 100.000 | No |
| 5.745 | 62.5815 | 190 | 1462.5815 | 100.000 | No |

SAR test exclusion table distance is > 50 mm @ Right Side (Main to edge)

| Frequency (GHz) | In Step 1 threshold Power (mW) | Distance between antenna and user (mm) | SAR Exclusion Threshold Power @ > 50 mm (mW) | EUT tune-up maximum power (mW) | SAR test |
|-----------------|--------------------------------|--|--|--------------------------------|----------|
| 2.442 | 95.9883 | 106 | 655.9883 | 112.202 | No |
| 5.260 | 65.4031 | 106 | 625.4031 | 100.000 | No |
| 5.580 | 63.5001 | 106 | 623.5001 | 100.000 | No |
| 5.745 | 62.5815 | 106 | 622.5815 | 102.329 | No |

6.3. Tissue Calibration Result

The dielectric parameters of the liquids were verified prior to the SAR evaluation using Agilent Dielectric Probe Kit and Agilent E5071C Vector Network Analyzer.

| Body Tissue Simulate Measurement | | | | |
|----------------------------------|-----------------------------------|-----------------------|----------------|-------------------|
| Frequency [MHz] | Description | Dielectric Parameters | | Liquid Temp. [°C] |
| | | ϵ_r | σ [s/m] | |
| 2450MHz | Reference result $\pm 5\%$ window | 52.70 | 1.95 | N/A |
| | | 50.065 to 55.335 | 1.853 to 2.048 | |
| | 2019. 12. 23 | 51.431 | 1.985 | 23.2 |

| Body Tissue Simulate Measurement | | | | |
|----------------------------------|-----------------------------------|-----------------------|----------------|-------------------|
| Frequency [MHz] | Description | Dielectric Parameters | | Liquid Temp. [°C] |
| | | ϵ_r | σ [s/m] | |
| 5300MHz | Reference result $\pm 5\%$ window | 48.88 | 5.416 | N/A |
| | | 46.436 to 51.324 | 5.145 to 5.687 | |
| | 2019. 12. 18 | 47.528 | 5.564 | 23.5 |
| | 2020. 01. 17 | 47.545 | 5.575 | 23.2 |

| Body Tissue Simulate Measurement | | | | |
|----------------------------------|-----------------------------------|-----------------------|----------------|-------------------|
| Frequency [MHz] | Description | Dielectric Parameters | | Liquid Temp. [°C] |
| | | ϵ_r | σ [s/m] | |
| 5600MHz | Reference result $\pm 5\%$ window | 48.47 | 5.766 | N/A |
| | | 46.047 to 50.894 | 5.478 to 6.054 | |
| | 2019. 12. 19 | 46.911 | 5.982 | 23.5 |
| | 2020. 01. 17 | 46.927 | 5.992 | 23.2 |

| Body Tissue Simulate Measurement | | | | |
|----------------------------------|-----------------------------------|-----------------------|----------------|-------------------|
| Frequency [MHz] | Description | Dielectric Parameters | | Liquid Temp. [°C] |
| | | ϵ_r | σ [s/m] | |
| 5800MHz | Reference result $\pm 5\%$ window | 48.20 | 6.00 | N/A |
| | | 45.790 to 50.610 | 5.700 to 6.300 | |
| | 2019. 12. 20 | 46.530 | 6.258 | 23.5 |
| | 2020. 01. 17 | 46.543 | 6.269 | 23.2 |

6.4. SAR Exposure Limits

SAR assessments have been made in line with the requirements of IEEE-1528, FCC Supplement C, and comply with ANSI/IEEE C95.1-1992 “Uncontrolled Environments” limits. These limits apply to a location which is deemed as “Uncontrolled Environment” which can be described as a situation where the general public may be exposed to an RF source with no prior knowledge or control over their exposure.

Limits for General Population/Uncontrolled Exposure (W/kg)

| Type Exposure | Uncontrolled Environment Limit |
|---|--------------------------------|
| Spatial Peak SAR (1g cube tissue for brain or body) | 1.60 W/kg |
| Spatial Average SAR (whole body) | 0.08 W/kg |
| Spatial Peak SAR (10g for hands, feet, ankles and wrist) | 4.00 W/kg |

6.5. Conducted Power Measurement

Note:

1. Per KDB 447498 D01, the reported SAR is the measured SAR value adjusted for maximum tune-up tolerance.
Scale Factor = tune-up limit power (mW)/EUT Conducted power (mW), where tune-up limit is the maximum rated power among all production units.
Scale SAR(W/kg)= Measured SAR(W/kg)* Scaling Factor
2. Per KDB 447498 D01, for each exposure position, if the highest output channel reported SAR ≤ 0.8 W/kg, other channels SAR testing is not necessary.
3. Per KDB 248227 D01, for OFDM transmission configuration in the 2.4G and 5G bands. An initial test configuration is determined by the highest maximum output power including tune-up tolerance. When multiple transmission modes(802.11 a/g/n/ac/ax) have same maximum power, largest channel bandwidth, lowest order modulation and lowest data rate, lowest order 802.11 mode is selected.(i.e. a, g, n, ac then ax)
4. Per KDB 248227 D01, when the highest reported SAR for the initial test configuration (when applicable, include subsequent highest output channels), according to the initial test position or fixed exposure position requirements, is adjusted by the ratio of the subsequent test configuration to initial test configuration specified maximum output power and the adjusted SAR is ≤ 1.2 W/kg, SAR is not required for that subsequent test configuration.
5. Per KDB 248227 D01, U-NII-1 and U-NII-2A bands have the same specified maximum output and tolerance; SAR is measured for U-NII-2A band first. Adjusted SAR of U-NII-2A band is ≤ 1.2 W/kg, SAR is not required for U-NII-1 band.
6. Per KDB 248227 D01, when the highest reported SAR for DSSS is adjusted by the ratio of OFDM to DSSS specified maximum output power and the adjusted SAR is ≤ 1.2 W/kg.
7. Pursuant section 2.8.1(2) KDB 865664 D01, when the original highest measured SAR is ≥ 0.80 W/kg, repeat that measurement once.
8. Pursuant section 2.8.1(3) KDB 865664 D01, perform a second repeated measurement only if the ratio of largest to smallest SAR for the original and first repeated measurements is > 1.20 or when the original or repeated measurement is ≥ 1.45 W/kg (~ 10% from the 1-g SAR limit)

6.5.1. For WLAN Function

| Type of Network | Channel | Frequency (MHz) | Output Power (dBm) | | | | | | SAR Test |
|-----------------|---------|-----------------|--------------------|---------------|--------------|---------------|---------------|--------------|---------------------|
| | | | Chain 0 (AUX) | | | Chain1 (Main) | | | |
| | | | Average Power | Tune-Up Limit | Scale Factor | Average Power | Tune-Up Limit | Scale Factor | |
| 802.11b | CH 1 | 2412 | 19.16 | 19.50 | --- | 19.35 | 19.50 | --- | No ^{NOTE2} |
| | CH 2 | 2417 | 19.91 | 20.00 | --- | 19.96 | 20.00 | --- | |
| | CH 7 | 2442 | 20.04 | 20.50 | 1.11 | 20.02 | 20.50 | 1.12 | Yes |
| | CH 10 | 2457 | 20.02 | 20.50 | --- | 19.95 | 20.00 | --- | No ^{NOTE2} |
| | CH 11 | 2462 | 19.08 | 19.50 | --- | 18.91 | 19.00 | --- | |
| | CH 12 | 2467 | 18.18 | 18.50 | --- | 18.08 | 18.50 | --- | |
| | CH 13 | 2472 | 13.08 | 13.50 | --- | 13.05 | 13.50 | --- | |
| 802.11g | CH 1 | 2412 | 16.72 | 17.00 | --- | 16.91 | 17.00 | --- | No ^{NOTE6} |
| | CH 2 | 2417 | 17.94 | 18.00 | --- | 17.9 | 18.00 | --- | |
| | CH 7 | 2442 | 19.63 | 20.00 | --- | 19.74 | 20.00 | --- | |
| | CH 10 | 2457 | 18.21 | 18.50 | --- | 18.05 | 18.50 | --- | |
| | CH 11 | 2462 | 17.47 | 17.50 | --- | 17.37 | 17.50 | --- | |
| | CH 12 | 2467 | 14.79 | 15.00 | --- | 14.78 | 15.00 | --- | |
| | CH 13 | 2472 | 1.52 | 2.00 | --- | 1.28 | 1.50 | --- | |

| Type of Network | Channel | Frequency (MHz) | Output Power (dBm) | | | | | | SAR Test |
|------------------|---------|-----------------|--------------------|---------------|--------------|---------------|---------------|--------------|-----------------------|
| | | | Chain 0 (AUX) | | | Chain1 (Main) | | | |
| | | | Average Power | Tune-Up Limit | Scale Factor | Average Power | Tune-Up Limit | Scale Factor | |
| 802.11n- HT20 | CH 1 | 2412 | 14.01 | 14.50 | --- | 14.23 | 14.50 | --- | No ^{NOTE4-3} |
| | CH 2 | 2417 | 15.45 | 15.50 | --- | 15.38 | 16.00 | --- | |
| | CH 7 | 2442 | 17.15 | 17.50 | --- | 17.13 | 17.50 | --- | |
| | CH 10 | 2457 | 15.63 | 16.00 | --- | 15.55 | 16.00 | --- | |
| | CH 11 | 2462 | 14.83 | 15.00 | --- | 14.63 | 15.0 | --- | |
| | CH 12 | 2467 | 11.95 | 12.00 | --- | 11.84 | 12.00 | --- | |
| | CH 13 | 2472 | -0.04 | 0 | --- | -0.86 | -0.5 | --- | |
| 802.11n- HT40 | CH 3 | 2422 | 13.83 | 14.00 | --- | 13.81 | 14.00 | --- | |
| | CH 4 | 2427 | 12.8 | 13.00 | --- | 12.73 | 13.00 | --- | |
| | CH 7 | 2442 | 14.65 | 15.00 | --- | 14.59 | 15.00 | --- | |
| | CH 8 | 2447 | 14.78 | 15.00 | --- | 14.73 | 15.00 | --- | |
| | CH 9 | 2452 | 13.14 | 13.50 | --- | 13.22 | 13.50 | --- | |
| | CH 10 | 2457 | 9.53 | 10.00 | --- | 9.42 | 9.50 | --- | |
| | CH 11 | 2462 | 1.41 | 1.50 | --- | 0.54 | 1.00 | --- | |

| Type of Network | Channel | Frequency (MHz) | Output Power (dBm) | | | | | | SAR Test |
|-----------------|---------|-----------------|--------------------|---------------|--------------|----------------|---------------|--------------|------------------------|
| | | | Chain 0 (AUX) | | | Chain 1 (Main) | | | |
| | | | Average Power | Tune-Up Limit | Scale Factor | Average Power | Tune-Up Limit | Scale Factor | |
| 802.11ax-HE20 | CH 1 | 2412 | 13.92 | 14.00 | --- | 14.12 | 14.50 | --- | No ^{NOTE4, 3} |
| | CH 2 | 2417 | 15.28 | 15.50 | --- | 15.22 | 15.50 | --- | |
| | CH 7 | 2442 | 17.03 | 17.50 | --- | 17.05 | 17.50 | --- | |
| | CH 10 | 2457 | 15.56 | 16.00 | --- | 15.39 | 16.00 | --- | |
| | CH 11 | 2462 | 14.68 | 15.00 | --- | 14.58 | 15.00 | --- | |
| | CH 12 | 2467 | 11.78 | 12.00 | --- | 11.79 | 12.00 | --- | |
| | CH 13 | 2472 | -0.11 | 0 | --- | -0.95 | -0.5 | --- | |
| 802.11ax-HE40 | CH 3 | 2422 | 13.66 | 14.00 | --- | 13.7 | 14.00 | --- | |
| | CH 4 | 2427 | 12.61 | 13.00 | --- | 12.49 | 12.50 | --- | |
| | CH 7 | 2442 | 14.47 | 14.50 | --- | 14.42 | 14.50 | --- | |
| | CH 8 | 2447 | 14.58 | 15.00 | --- | 14.55 | 15.00 | --- | |
| | CH 9 | 2452 | 12.96 | 13.00 | --- | 13.00 | 13.50 | --- | |
| | CH 10 | 2457 | 9.28 | 9.50 | --- | 9.24 | 9.50 | --- | |
| | CH 11 | 2462 | 1.06 | 1.50 | --- | 0.14 | 0.5 | --- | |

| Type of Network | RU Config | Frequency (MHz) | Output Power (dBm) | | | | | | SAR Test |
|-----------------|-----------|-----------------|--------------------|---------------|--------------|----------------|---------------|--------------|------------------------|
| | | | Chain 0 (AUX) | | | Chain 1 (Main) | | | |
| | | | Average Power | Tune-Up Limit | Scale Factor | Average Power | Tune-Up Limit | Scale Factor | |
| 802.11ax-HE20 | 26/0 | 2412 | 14.13 | 14.50 | --- | 14.45 | 14.50 | --- | No ^{NOTE4, 3} |
| | 52/37 | | 14.26 | 14.50 | --- | 14.43 | 14.50 | --- | |
| | 106/53 | | 14.28 | 14.50 | --- | 14.48 | 14.50 | --- | |
| | 26/8 | 2472 | -1.36 | -1.0 | --- | -2.57 | -2.5 | --- | |
| | 52/40 | | -1.13 | -1.0 | --- | -2.29 | -2.0 | --- | |
| | 106/54 | | -1.02 | -1.0 | --- | -2.05 | -2.0 | --- | |
| 802.11ax-HE40 | 242/61 | 2422 | 13.85 | 14.00 | --- | 14.08 | 14.50 | --- | |
| | 242/62 | 2467 | 1.27 | 1.50 | --- | 1.17 | 1.50 | --- | |

| Type of Network | Channel | Frequency (MHz) | Output Power (dBm) | | | | | | SAR Test | |
|-----------------|---------|-----------------|--------------------|---------------|--------------|----------------|---------------|--------------|----------|-------------------------|
| | | | Chain 0 (AUX) | | | Chain 1 (Main) | | | | |
| | | | Average Power | Tune-Up Limit | Scale Factor | Average Power | Tune-Up Limit | Scale Factor | | |
| 802.11a | I | CH 36 | 5180 | 16.22 | 16.50 | --- | 16.10 | 16.50 | --- | No ^{NOTE5 · 3} |
| | | CH 40 | 5200 | 16.19 | 16.50 | --- | 16.13 | 16.50 | --- | |
| | | CH 48 | 5240 | 11.61 | 12.00 | --- | 11.35 | 11.50 | --- | |
| | II-2A | CH 52 | 5260 | 19.96 | 20.00 | 1.01 | 19.94 | 20.00 | 1.01 | Yes |
| | | CH 60 | 5300 | 18.98 | 19.00 | --- | 18.77 | 19.00 | --- | No ^{NOTE2} |
| | | CH 64 | 5320 | 18.26 | 18.50 | --- | 17.90 | 18.00 | --- | |
| | II-2C | CH 100 | 5500 | 18.49 | 18.50 | --- | 18.29 | 18.50 | --- | No ^{NOTE2 · 3} |
| | | CH 116 | 5580 | 19.92 | 20.00 | 1.02 | 19.61 | 20.00 | 1.09 | Yes |
| | | CH 140 | 5700 | 17.75 | 18.00 | --- | 18.26 | 18.50 | --- | No ^{NOTE2 · 3} |
| | | CH 144 | 5720 | 20.01 | 20.10 | --- | 19.71 | 20.00 | --- | |
| | III | CH 149 | 5745 | 19.85 | 20.00 | 1.04 | 20.08 | 20.10 | 1.00 | Yes |
| | | CH 157 | 5785 | 19.72 | 20.00 | --- | 20.01 | 20.10 | --- | No ^{NOTE2 · 3} |
| | | CH 165 | 5825 | 19.67 | 20.00 | --- | 19.79 | 20.00 | --- | |

| Type of Network | Channel | Frequency (MHz) | Output Power (dBm) | | | | | | SAR Test | |
|------------------|---------|-----------------|--------------------|---------------|--------------|---------------|---------------|--------------|----------|-------------------------|
| | | | Chain 0 | | | Chain 1 | | | | |
| | | | Average Power | Tune-Up Limit | Scale Factor | Average Power | Tune-Up Limit | Scale Factor | | |
| 802.11n- HT20 | I | CH 36 | 5180 | 13.65 | 14.00 | --- | 13.58 | 14.00 | --- | No ^{NOTE4 · 3} |
| | | CH 40 | 5200 | 13.68 | 14.00 | --- | 13.61 | 14.00 | --- | |
| | | CH 48 | 5240 | 8.26 | 8.50 | --- | 8.45 | 8.50 | --- | |
| | II-2A | CH 52 | 5260 | 17.61 | 18.00 | --- | 17.49 | 17.50 | --- | |
| | | CH 60 | 5300 | 16.35 | 16.50 | --- | 16.07 | 16.50 | --- | |
| | | CH 64 | 5320 | 15.41 | 15.50 | --- | 15.19 | 15.50 | --- | |
| | II-2C | CH 100 | 5500 | 15.82 | 16.00 | --- | 15.55 | 16.00 | --- | |
| | | CH 116 | 5580 | 17.52 | 18.00 | --- | 17.29 | 17.50 | --- | |
| | | CH 140 | 5700 | 15.11 | 15.50 | --- | 14.57 | 15.00 | --- | |
| | | CH 144 | 5720 | 17.49 | 17.50 | --- | 17.21 | 17.50 | --- | |
| | III | CH 149 | 5745 | 17.26 | 17.50 | --- | 17.24 | 17.50 | --- | |
| | | CH 157 | 5785 | 17.35 | 17.50 | --- | 17.25 | 17.50 | --- | |
| | | CH 165 | 5825 | 17.28 | 17.50 | --- | 17.26 | 17.50 | --- | |

| Type of Network | Channel | Frequency (MHz) | Output Power (dBm) | | | | | | SAR Test | |
|-----------------|---------|-----------------|--------------------|---------------|--------------|---------------|---------------|--------------|----------|------------------------|
| | | | Chain 0 | | | Chain 1 | | | | |
| | | | Average Power | Tune-Up Limit | Scale Factor | Average Power | Tune-Up Limit | Scale Factor | | |
| 802.11n-HT40 | I | CH 38 | 5190 | 14.32 | 14.50 | --- | 14.27 | 14.50 | --- | No ^{NOTE4, 3} |
| | | CH 46 | 5230 | 11.68 | 12.00 | --- | 11.43 | 11.50 | --- | |
| | II-2A | CH 54 | 5270 | 16.69 | 17.00 | --- | 16.61 | 17.00 | --- | |
| | | CH 62 | 5310 | 14.78 | 15.00 | --- | 14.52 | 15.00 | --- | |
| | II-2C | CH 102 | 5510 | 15.10 | 15.50 | --- | 14.69 | 15.00 | --- | |
| | | CH 110 | 5550 | 15.89 | 16.00 | --- | 15.65 | 16.00 | --- | |
| | | CH 134 | 5670 | 17.35 | 17.50 | --- | 16.88 | 17.00 | --- | |
| | III | CH 142 | 5710 | 17.98 | 18.00 | --- | 17.55 | 18.00 | --- | |
| CH 151 | | 5755 | 17.68 | 18.00 | --- | 17.65 | 18.00 | --- | | |
| 802.11ac-VHT80 | I | CH 52 | 5210 | 13.95 | 14.00 | --- | 13.91 | 14.00 | --- | No ^{NOTE4, 3} |
| | | CH 58 | 5290 | 14.79 | 15.00 | --- | 14.58 | 15.00 | --- | |
| | II-2C | CH 106 | 5530 | 15.64 | 16.00 | --- | 15.24 | 15.50 | --- | |
| | | CH 133 | 5610 | 17.83 | 18.00 | --- | 17.64 | 18.0 | --- | |
| | | CH 138 | 5690 | 18.19 | 18.50 | --- | 17.84 | 18.00 | --- | |
| III | CH 155 | 5775 | 16.50 | 17.00 | --- | 16.53 | 17.00 | --- | | |
| 802.11ac-VHT160 | I/II-2A | CH 50 | 5250 | 14.26 | 14.50 | --- | 14.13 | 14.50 | --- | No ^{NOTE4, 3} |
| | II-2C | CH 114 | 5570 | 11.51 | 12.00 | --- | 11.39 | 12.00 | --- | |

| Type of Network | Channel | Frequency (MHz) | Output Power (dBm) | | | | | | SAR Test | |
|-----------------|---------|-----------------|--------------------|---------------|--------------|---------------|---------------|--------------|----------|-------------------------|
| | | | Chain 0 | | | Chain 1 | | | | |
| | | | Average Power | Tune-Up Limit | Scale Factor | Average Power | Tune-Up Limit | Scale Factor | | |
| 802.11ax-HE20 | I | CH 36 | 5180 | 14.02 | 14.50 | --- | 13.93 | 14.00 | --- | No ^{NOTE4 · 3} |
| | | CH 40 | 5200 | 14.03 | 14.50 | --- | 13.94 | 14.00 | --- | |
| | | CH 48 | 5240 | 8.06 | 8.50 | --- | 8.27 | 8.50 | --- | |
| | II-2A | CH 52 | 5260 | 17.47 | 17.50 | --- | 17.44 | 17.50 | --- | |
| | | CH 60 | 5300 | 16.22 | 16.50 | --- | 16.01 | 16.50 | --- | |
| | | CH 64 | 5320 | 15.31 | 15.50 | --- | 15.06 | 15.50 | --- | |
| | II-2C | CH 100 | 5500 | 15.76 | 16.00 | --- | 15.46 | 16.00 | --- | |
| | | CH 116 | 5580 | 17.38 | 17.50 | --- | 17.27 | 17.50 | --- | |
| | | CH 140 | 5700 | 15.01 | 15.50 | --- | 14.45 | 14.50 | --- | |
| | III | CH 144 | 5720 | 17.36 | 17.50 | --- | 17.12 | 17.50 | --- | |
| | | CH 149 | 5745 | 17.10 | 17.50 | --- | 17.07 | 17.50 | --- | |
| | | CH 157 | 5785 | 17.22 | 17.50 | --- | 17.16 | 17.50 | --- | |
| 802.11ax-HE40 | I | CH 38 | 5190 | 14.05 | 14.50 | --- | 13.99 | 14.00 | --- | No ^{NOTE4 · 3} |
| | | CH 46 | 5230 | 11.38 | 11.50 | --- | 11.17 | 11.50 | --- | |
| | II-2A | CH 54 | 5270 | 16.45 | 16.50 | --- | 16.32 | 17.00 | --- | |
| | | CH 62 | 5310 | 14.47 | 14.50 | --- | 14.26 | 14.50 | --- | |
| | II-2C | CH 102 | 5510 | 14.87 | 15.00 | --- | 14.47 | 14.50 | --- | |
| | | CH 110 | 5550 | 15.67 | 16.00 | --- | 15.44 | 15.50 | --- | |
| | | CH 134 | 5670 | 17.03 | 17.50 | --- | 16.61 | 17.00 | --- | |
| | III | CH 142 | 5710 | 17.73 | 18.00 | --- | 17.30 | 17.50 | --- | |
| CH 151 | | 5755 | 17.41 | 17.50 | --- | 17.34 | 17.50 | --- | | |
| 802.11ax-HE80 | I | CH 52 | 5210 | 13.32 | 13.50 | --- | 13.56 | 14.00 | --- | No ^{NOTE4 · 3} |
| | | CH 58 | 5290 | 14.33 | 14.50 | --- | 14.34 | 14.50 | --- | |
| | II-2C | CH 106 | 5530 | 15.28 | 15.50 | --- | 15.01 | 15.50 | --- | |
| | | CH 133 | 5610 | 17.71 | 18.00 | --- | 17.47 | 17.50 | --- | |
| | III | CH 138 | 5690 | 17.98 | 18.00 | --- | 17.62 | 18.00 | --- | |
| 802.11ax-HE160 | I/II-2A | CH 50 | 5250 | 13.26 | 13.50 | --- | 13.18 | 13.50 | --- | No ^{NOTE4 · 3} |
| | II-2C | CH 114 | 5570 | 11.23 | 12.50 | --- | 11.15 | 11.50 | --- | |

| Type of Network | Channel | Frequency (MHz) | RU Config | Output Power (dBm) | | | | | | SAR Test | |
|-----------------|---------|-----------------|-----------|--------------------|---------------|--------------|---------------|---------------|--------------|----------|---------------------------|
| | | | | Chain 0 | | | Chain 1 | | | | |
| | | | | Average Power | Tune-Up Limit | Scale Factor | Average Power | Tune-Up Limit | Scale Factor | | |
| 802.11ax-HE20 | I | CH 36 | 5180 | 26/0 | 4.69 | 5.00 | --- | 4.10 | 4.50 | --- | No ^{NOTE} 4.3 |
| | | | | 52/37 | 7.86 | 8.00 | --- | 7.37 | 7.50 | --- | |
| | | | | 106/53 | 10.89 | 11.00 | --- | 10.37 | 10.50 | --- | |
| | II-2A | CH 64 | 5320 | 26/8 | 11.82 | 12.00 | --- | 11.63 | 12.00 | --- | |
| | | | | 52/40 | 12.06 | 12.50 | --- | 11.92 | 12.00 | --- | |
| | | | | 106/54 | 15.55 | 16.00 | --- | 15.35 | 15.50 | --- | |
| | II-2C | CH 100 | 5500 | 26/0 | 11.74 | 12.00 | --- | 11.43 | 12.00 | --- | |
| | | | | 52/37 | 14.76 | 15.00 | --- | 14.48 | 14.50 | --- | |
| | | | | 106/53 | 15.78 | 16.00 | --- | 15.64 | 16.00 | --- | |
| | | CH 140 | 5700 | 26/8 | 11.89 | 12.00 | --- | 11.42 | 11.50 | --- | |
| | | | | 52/40 | 13.06 | 13.50 | --- | 12.59 | 13.00 | --- | |
| | | | | 106/54 | 14.72 | 15.00 | --- | 14.17 | 14.50 | --- | |
| | III | CH 149 | 5745 | 26/0 | 11.58 | 12.00 | --- | 11.45 | 11.50 | --- | |
| | | | | 52/37 | 14.60 | 15.00 | --- | 14.54 | 15.00 | --- | |
| | | | | 106/53 | 17.17 | 17.50 | --- | 17.15 | 17.50 | --- | |
| CH 165 | | 5825 | 26/8 | 16.65 | 17.00 | --- | 16.42 | 16.50 | --- | | |
| | | | 52/40 | 16.86 | 17.00 | --- | 16.68 | 17.00 | --- | | |
| 106/54 | 16.96 | 17.00 | --- | 16.64 | 17.00 | --- | | | | | |
| 802.11ax-HE40 | I | CH 38 | 5190 | 242/61 | 13.62 | 14.00 | --- | 13.29 | 14.50 | --- | No ^{NOTE} 4.3 |
| | II-2A | CH 62 | 5310 | 242/62 | 14.59 | 15.00 | --- | 14.36 | 14.50 | --- | |
| | II-2C | CH 102 | 5510 | 242/61 | 15.05 | 15.50 | --- | 14.75 | 15.00 | --- | |
| | | CH 142 | 5710 | 242/62 | 16.98 | 17.00 | --- | 16.64 | 17.00 | --- | |
| | III | CH 151 | 5755 | 242/61 | 17.03 | 17.50 | --- | 17.02 | 17.50 | --- | |
| | | CH 159 | 5795 | 242/62 | 16.98 | 17.00 | --- | 16.96 | 17.00 | --- | |
| 802.11ax-HE80 | I | CH 52 | 5210 | 484/65 | 16.37 | 16.50 | --- | 15.93 | 16.00 | --- | No ^{NOTE} 4.3 |
| | II-2A | CH 58 | 5290 | 484/66 | 12.33 | 12.50 | --- | 11.76 | 12.00 | --- | |
| | II-2C | CH 106 | 5530 | 484/65 | 13.85 | 14.00 | --- | 13.53 | 14.00 | --- | |
| | | CH 133 | 5610 | 484/66 | 15.78 | 16.00 | --- | 15.62 | 16.00 | --- | |
| | III | CH 155 | 5775 | 484/65 | 15.39 | 15.50 | --- | 16.22 | 16.50 | --- | |
| | | | | 484/66 | 15.71 | 16.00 | --- | 15.45 | 15.50 | --- | |
| 802.11ax-HE160 | II-2A | CH 50 | 5250 | 996/67 | 16.34 | 16.50 | --- | 16.00 | 16.50 | --- | No ^{NOTE} 4.3 |
| | | | | 996/S67 | 10.47 | 10.50 | --- | 10.34 | 10.50 | --- | |
| | II-2C | CH 114 | 5570 | 996/67 | 10.14 | 10.50 | --- | 9.53 | 10.00 | --- | |
| | | | | 996/S67 | 9.90 | 10.00 | --- | 9.71 | 10.00 | --- | |

6.5.2. For BT Function

| Type of Network | Channel | Frequency (MHz) | Max Output Power (dBm) | Tune-Up Limit | Scale Factor | SAR Test |
|--------------------|---------|-----------------|------------------------|---------------|--------------|----------|
| Bluetooth-GFSK | CH 0 | 2402 | 9.14 | 9.50 | --- | No |
| | CH 39 | 2441 | 9.59 | 10.0 | 1.00 | Yes |
| | CH 78 | 2480 | 9.48 | 9.50 | --- | No |
| Bluetooth-8-DPSK | CH 0 | 2402 | 6.89 | 7.0 | --- | No |
| | CH 39 | 2441 | 7.55 | 8.0 | --- | No |
| | CH 78 | 2480 | 7.00 | 7.5 | --- | No |
| BLE (1M) | CH 37 | 2402 | 4.85 | 5.0 | --- | No |
| | CH 17 | 2440 | 5.37 | 5.5 | --- | No |
| | CH 39 | 2480 | 4.66 | 5.0 | --- | No |
| BLE (2M) | CH 37 | 2402 | 4.84 | 5.0 | --- | No |
| | CH 17 | 2440 | 5.37 | 5.5 | --- | No |
| | CH 39 | 2480 | 4.66 | 5.0 | --- | No |
| BLE (PHY Coded S2) | CH 37 | 2402 | 4.82 | 5.0 | --- | No |
| | CH 17 | 2440 | 5.36 | 5.5 | --- | No |
| | CH 39 | 2480 | 4.65 | 5.0 | --- | No |
| BLE (PHY Coded S8) | CH 37 | 2402 | 4.82 | 5.0 | --- | No |
| | CH 17 | 2440 | 5.36 | 5.5 | --- | No |
| | CH 39 | 2480 | 4.65 | 5.0 | --- | No |

6.6. SAR Test Result

| | | | |
|--------------|---------------------------------|------------|-------------|
| Test Date | 2019. 12. 23 | Temp./Hum. | 24°C/48% |
| Test Voltage | AC 120V, 60Hz (with AC Adapter) | Tested by | Brain Hsieh |

| Liquid Temperature : 23.2°C | | | | | | | Depth of Liquid: > 15cm | | | |
|-----------------------------|---------------------|------------------|--------------------------|-----------|-----------------------|-----------------------|-------------------------|--------------|-----------|--------------|
| Test Mode: 2.4GHz | | | | | | | | | | |
| Plot No. | Test Position: Body | Antenna Position | Separation Distance (cm) | Frequency | Conducted Power (dBm) | Maximum Tune-up (dBm) | SAR 1g (W/kg) | Scale Factor | Scale SAR | Limit (W/kg) |
| 802.11b | | | | | | | | | | |
| Antenna B: Chain 1 (Main) | | | | | | | | | | |
| 8 | Rear | Fixed | 0 | 2442 | 20.02 | 20.5 | 0.258 | 1.12 | 0.29 | 1.60 |
| Antenna A: Chain 0 (AUX) | | | | | | | | | | |
| 7 | Rear | Fixed | 0 | 2442 | 20.04 | 20.5 | 0.184 | 1.11 | 0.20 | 1.60 |

| | | | |
|--------------|---------------------------------|------------|-----------------|
| Test Date | 2019. 12. 18~ 2020. 01. 17 | Temp./Hum. | 22~ 24°C/44~60% |
| Test Voltage | AC 120V, 60Hz (with AC Adapter) | Tested by | Brain Hsieh |

| Liquid Temperature : 23.5°C | | | | Depth of Liquid: > 15cm | | | | | | |
|-----------------------------|---------------------|------------------|--------------------------|-------------------------|-----------------------|-----------------------|---------------|--------------|-----------|--------------|
| Test Mode: 5GHz | | | | | | | | | | |
| Plot No. | Test Position: Body | Antenna Position | Separation Distance (cm) | Frequency | Conducted Power (dBm) | Maximum Tune-up (dBm) | SAR 1g (W/kg) | Scale Factor | Scale SAR | Limit (W/kg) |
| 802.11a (NII-2A) | | | | | | | | | | |
| Antenna B: Chain 1 (Main) | | | | | | | | | | |
| 15 | Rear | Fixed | 0 | 5240 | 11.35 | 11.5 | 0.894 | 1.04 | 0.93 | 1.60 |
| 21* | Rear | Fixed | 0 | 5240 | 11.35 | 11.5 | 0.903 | 1.04 | 0.93 | 1.60 |
| 2 | Rear | Fixed | 0 | 5260 | 19.94 | 20.0 | 0.905 | 1.01 | 0.92 | 1.60 |
| 11* | Rear | Fixed | 0 | 5260 | 11.94 | 20.0 | 0.879 | 6.40 | 5.62 | 1.60 |
| Antenna A: Chain 0 (AUX) | | | | | | | | | | |
| 14 | Rear | Fixed | 0 | 5240 | 11.61 | 12.0 | 0.637 | 1.09 | 0.70 | 1.60 |
| 1 | Rear | Fixed | 0 | 5260 | 19.96 | 20.0 | 0.654 | 1.01 | 0.66 | 1.60 |
| 802.11a (NII-2C) | | | | | | | | | | |
| Antenna B: Chain 1 (Main) | | | | | | | | | | |
| 17 | Rear | Fixed | 0 | 5500 | 18.29 | 18.5 | 0.945 | 1.05 | 0.99 | 1.60 |
| 22* | Rear | Fixed | 0 | 5500 | 18.29 | 18.5 | 0.963 | 1.05 | 1.01 | 1.60 |
| 4 | Rear | Fixed | 0 | 5580 | 19.61 | 20.0 | 1.070 | 1.09 | 1.17 | 1.60 |
| 12* | Rear | Fixed | 0 | 5580 | 19.61 | 20.0 | 1.090 | 1.09 | 1.19 | 1.60 |
| Antenna A: Chain 0 (AUX) | | | | | | | | | | |
| 16 | Rear | Fixed | 0 | 5500 | 18.49 | 18.5 | 0.462 | 1.00 | 0.46 | 1.60 |
| 3 | Rear | Fixed | 0 | 5580 | 19.92 | 20.0 | 0.475 | 1.02 | 0.48 | 1.60 |
| 802.11a (NII-III) | | | | | | | | | | |
| Antenna B: Chain 1 (Main) | | | | | | | | | | |
| 6 | Rear | Fixed | 0 | 5745 | 20.08 | 20.1 | 1.110 | 1.00 | 1.12 | 1.60 |
| 13* | Rear | Fixed | 0 | 5745 | 20.08 | 20.1 | 1.030 | 1.00 | 1.03 | 1.60 |
| 19 | Rear | Fixed | 0 | 5785 | 20.01 | 20.1 | 0.994 | 1.02 | 1.01 | 1.60 |
| 23* | Rear | Fixed | 0 | 5785 | 20.01 | 20.1 | 1.030 | 1.02 | 1.05 | 1.60 |
| Antenna A: Chain 0 (AUX) | | | | | | | | | | |
| 5 | Rear | Fixed | 0 | 5745 | 19.85 | 20.0 | 0.364 | 1.04 | 0.38 | 1.60 |
| 18 | Rear | Fixed | 0 | 5785 | 19.72 | 20.0 | 0.345 | 1.07 | 0.37 | 1.60 |

*: is Repeated SAR Measurement

| | | | |
|--------------|---------------------------------|------------|-------------|
| Test Date | 2019. 12. 23 | Temp./Hum. | 24°C/48% |
| Test Voltage | AC 120V, 60Hz (with AC Adapter) | Tested by | Brain Hsieh |

| Liquid Temperature : 23.2°C | | | | | | Depth of Liquid: > 15cm | | | | |
|-----------------------------|---------------------|------------------|--------------------------|-----------|-----------------------|-------------------------|---------------|--------------|-----------|--------------|
| Test Mode: BT-GFSK | | | | | | | | | | |
| Plot No. | Test Position: Body | Antenna Position | Separation Distance (cm) | Frequency | Conducted Power (dBm) | Maximum Tune-up (dBm) | SAR 1g (W/kg) | Scale Factor | Scale SAR | Limit (W/kg) |
| Antenna A: Chain 0 (AUX) | | | | | | | | | | |
| 9 | Rear | Fixed | 0 | 2441 | 9.59 | 10.0 | 0.015 | 1.10 | 0.02 | 1.60 |



*Audix Technology Corp.
No. 53-11, Dingfu, Linkou, Dist.,
New Taipei City 244, Taiwan*

APPENDIX A

*Tel: +886 2 26099301
Fax: +886 2 26099303*

APPENDIX A

GRAPH RESULT

(Model: 14Z995)

Date: 12/23/2019

Test Laboratory: Audix_SAR Lab

P8 802.11b CH7 2442MHz Ant B

DUT: 14Z995

Communication System: UID 0, WIFI 2.4G 802.11B (0); Frequency: 2442 MHz; Duty Cycle: 1:1

Medium parameters used: $f = 2442$ MHz; $\sigma = 1.974$ S/m; $\epsilon_r = 51.459$; $\rho = 1000$ kg/m³

Phantom section: Flat Section

DASY Configuration:

- Probe: EX3DV4 - SN3855; ConvF(7.63, 7.63, 7.63); Calibrated: 9/26/2019;
- Sensor-Surface: 2mm (Mechanical Surface Detection), $z = 1.0, 31.0$
- Electronics: DAE4 Sn1337; Calibrated: 9/18/2019
- Phantom: ELI v5.0; Type: QDOVA002AA; Serial: TP:1170
- DASY52 52.8.8(1258); SEMCAD X 14.6.10(7373)

Area Scan (4x7x1): Measurement grid: $dx=20$ mm, $dy=20$ mm

Maximum value of SAR (measured) = 0.339 W/kg

Zoom Scan (5x5x7)/Cube 0: Measurement grid: $dx=8$ mm, $dy=8$ mm, $dz=5$ mm

Reference Value = 1.965 V/m; Power Drift = 0.45 dB

Peak SAR (extrapolated) = 0.510 W/kg

SAR(1 g) = 0.258 W/kg; SAR(10 g) = 0.145 W/kg

Maximum value of SAR (measured) = 0.364 W/kg

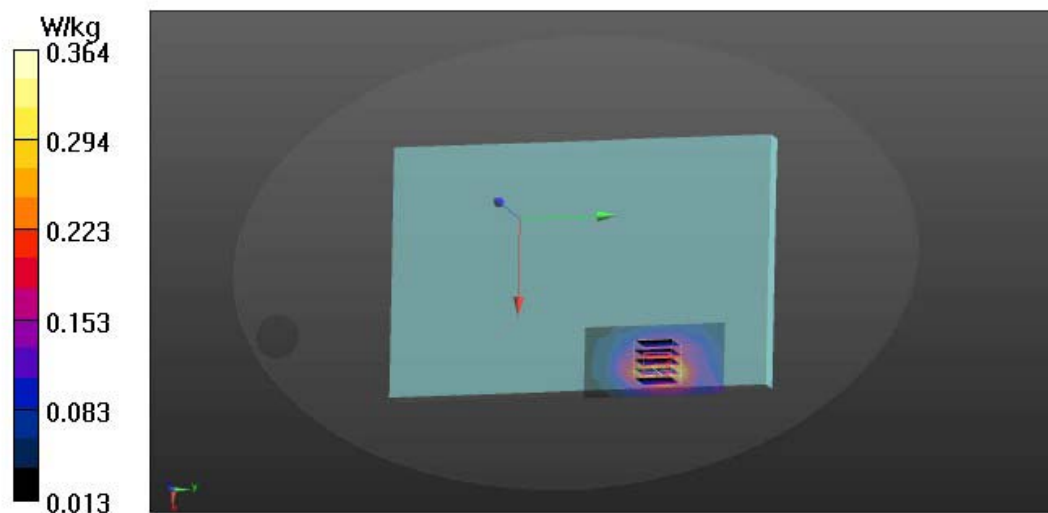

Date: 12/23/2019

Test Laboratory: Audix_SAR Lab

P7 802.11b CH7 2442MHz Ant A

DUT: 14Z995

Communication System: UID 0, WIFI 2.4G 802.11B (0); Frequency: 2442 MHz; Duty Cycle: 1:1

Medium parameters used: $f = 2442$ MHz; $\sigma = 1.974$ S/m; $\epsilon_r = 51.459$; $\rho = 1000$ kg/m³

Phantom section: Flat Section

DASY Configuration:

- Probe: EX3DV4 - SN3855; ConvF(7.63, 7.63, 7.63); Calibrated: 9/26/2019;
- Sensor-Surface: 2mm (Mechanical Surface Detection), $z = 1.0, 31.0$
- Electronics: DAE4 Sn1337; Calibrated: 9/18/2019
- Phantom: ELI v5.0; Type: QDOVA002AA; Serial: TP:1170
- DASY52 52.8.8(1258); SEMCAD X 14.6.10(7373)

Area Scan (4x7x1): Measurement grid: $dx=20$ mm, $dy=20$ mm

Maximum value of SAR (measured) = 0.246 W/kg

Zoom Scan (5x5x7)/Cube 0: Measurement grid: $dx=8$ mm, $dy=8$ mm, $dz=5$ mm

Reference Value = 1.852 V/m; Power Drift = 1.27 dB

Peak SAR (extrapolated) = 0.347 W/kg

SAR(1 g) = 0.184 W/kg; SAR(10 g) = 0.109 W/kg

Maximum value of SAR (measured) = 0.255 W/kg

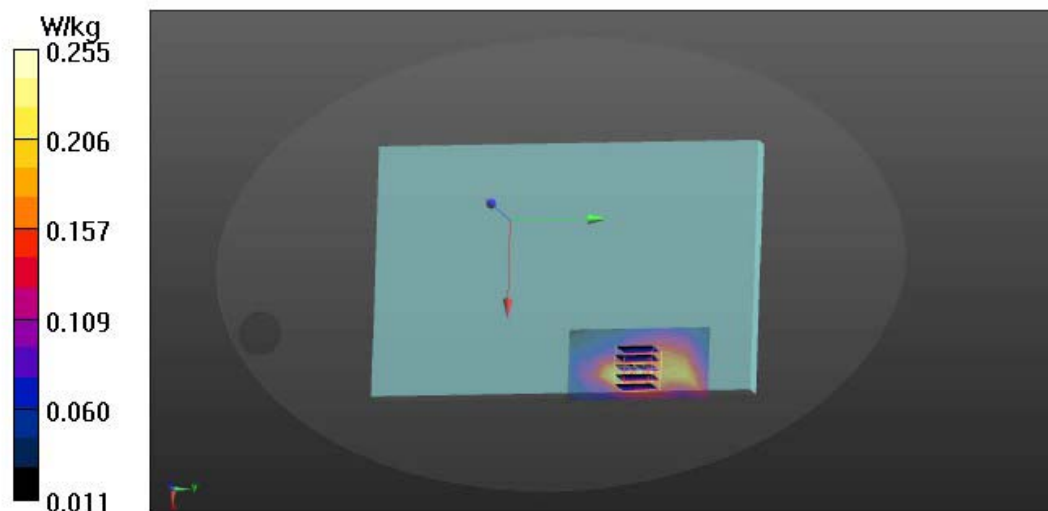

Date: 12/18/2019

Test Laboratory: Audix_SAR Lab

P15 802.11a CH48 5240MHz ant B**DUT: 14Z995**

Communication System: UID 0, WIFI 5G 802.11a (0); Frequency: 5240 MHz; Duty Cycle: 1:1

Medium parameters used: $f = 5240$ MHz; $\sigma = 5.477$ S/m; $\epsilon_r = 47.658$; $\rho = 1000$ kg/m³

Phantom section: Flat Section

DASY Configuration:

- Probe: EX3DV4 - SN3855; ConvF(4.56, 4.56, 4.56); Calibrated: 9/26/2019;
- Sensor-Surface: 2mm (Mechanical Surface Detection), $z = 1.0, 31.0$
- Electronics: DAE4 Sn1337; Calibrated: 9/18/2019
- Phantom: ELI v5.0; Type: QDOVA002AA; Serial: TP:1170
- DASY52 52.8.8(1258); SEMCAD X 14.6.10(7373)

Area Scan (9x13x1): Measurement grid: $dx=10$ mm, $dy=10$ mm

Maximum value of SAR (measured) = 0.829 W/kg

Zoom Scan (7x7x9)/Cube 0: Measurement grid: $dx=4$ mm, $dy=4$ mm, $dz=2.5$ mm

Reference Value = 0.8390 V/m; Power Drift = -0.23 dB

Peak SAR (extrapolated) = 3.32 W/kg

SAR(1 g) = 0.894 W/kg; SAR(10 g) = 0.312 W/kg

Maximum value of SAR (measured) = 1.48 W/kg

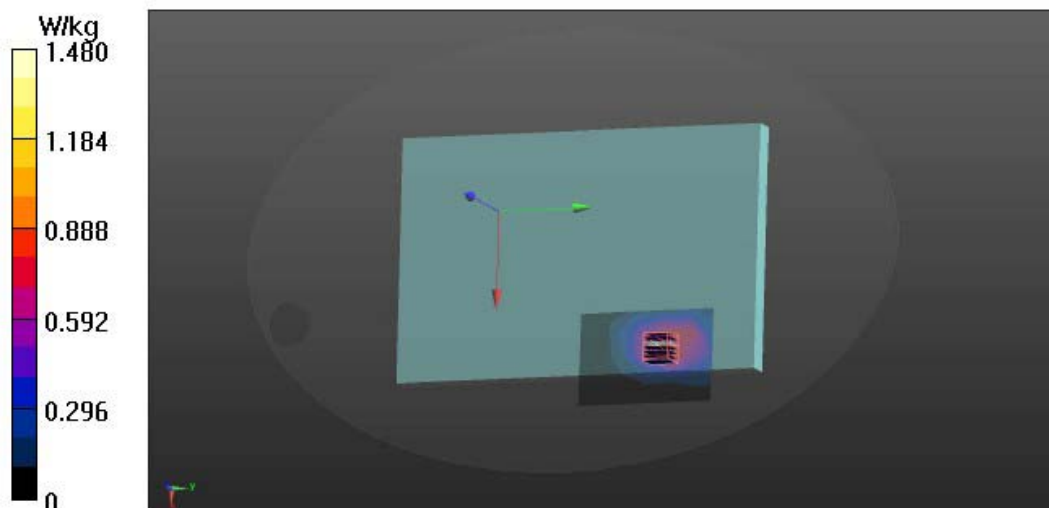

Date: 1/17/2020

Test Laboratory: Audix_SAR Lab

P21 802.11a CH48 5240MHz Ant B

DUT: 14Z995

Communication System: UID 0, WIFI 5G 802.11a (0); Frequency: 5240 MHz; Duty Cycle: 1:1

Medium parameters used: $f = 5240$ MHz, $\sigma = 5.487$ S/m, $\epsilon_r = 47.677$; $\rho = 1000$ kg/m³

Phantom section: Flat Section

DASY Configuration:

- Probe: EX3DV4 - SN3855; ConvF(4.56, 4.56, 4.56); Calibrated: 9/26/2019;
- Sensor-Surface: 2mm (Mechanical Surface Detection), $z = 1.0, 31.0$
- Electronics: DAE4 Sn1337; Calibrated: 9/18/2019
- Phantom: ELI v5.0; Type: QDOVA002AA; Serial: TP:1170
- DASY52 52.8.8(1258); SEMCAD X 14.6.10(7373)

Area Scan (5x7x1): Measurement grid: $dx=10$ mm, $dy=10$ mm

Maximum value of SAR (measured) = 0.988 W/kg

Zoom Scan (7x7x9)/Cube 0: Measurement grid: $dx=4$ mm, $dy=4$ mm, $dz=2.5$ mm

Reference Value = 0.8840 V/m; Power Drift = 1.74 dB

Peak SAR (extrapolated) = 3.12 W/kg

SAR(1 g) = 0.903 W/kg; SAR(10 g) = 0.318 W/kg

Maximum value of SAR (measured) = 1.72 W/kg

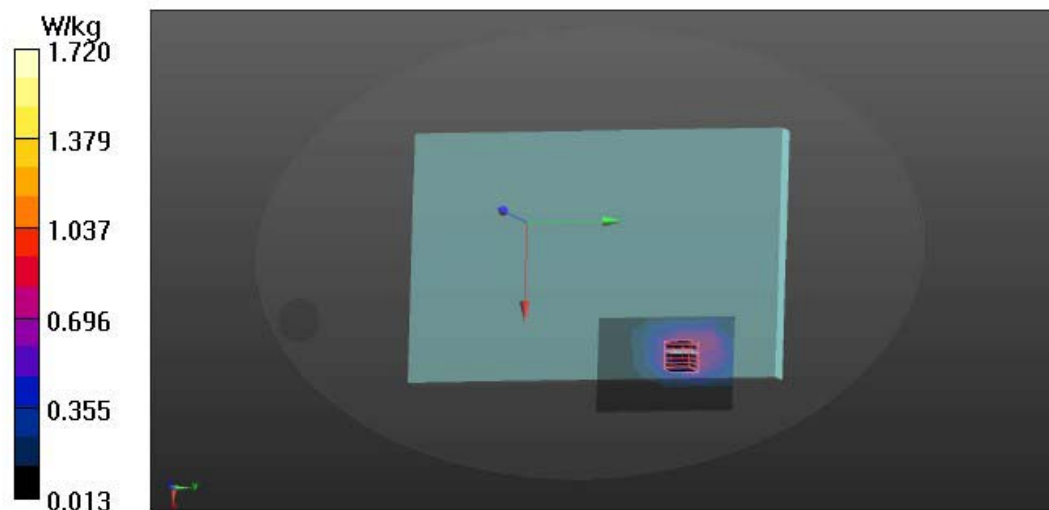

Date: 12/18/2019

Test Laboratory: Audix_SAR Lab

P2 802.11a CH52 5260MHz Ant B

DUT: 14Z995

Communication System: UID 0, WIFI 5G 802.11a (0); Frequency: 5260 MHz; Duty Cycle: 1:1

Medium parameters used: $f = 5260$ MHz; $\sigma = 5.502$ S/m; $\epsilon_r = 47.617$; $\rho = 1000$ kg/m³

Phantom section: Flat Section

DASY Configuration:

- Probe: EX3DV4 - SN3855; ConvF(4.44, 4.44, 4.44); Calibrated: 9/26/2019;
- Sensor-Surface: 2mm (Mechanical Surface Detection), $z = 1.0, 31.0$
- Electronics: DAE4 Sn1337; Calibrated: 9/18/2019
- Phantom: ELI v5.0; Type: QDOVA002AA; Serial: TP:1170
- DASY52 52.8.8(1258); SEMCAD X 14.6.10(7373)

Area Scan (9x13x1): Measurement grid: $dx=10$ mm, $dy=10$ mm

Maximum value of SAR (measured) = 0.990 W/kg

Zoom Scan (7x7x9)/Cube 0: Measurement grid: $dx=4$ mm, $dy=4$ mm, $dz=2.5$ mm

Reference Value = 0.8650 V/m; Power Drift = 0.84 dB

Peak SAR (extrapolated) = 3.51 W/kg

SAR(1 g) = 0.905 W/kg; SAR(10 g) = 0.319 W/kg

Maximum value of SAR (measured) = 1.70 W/kg

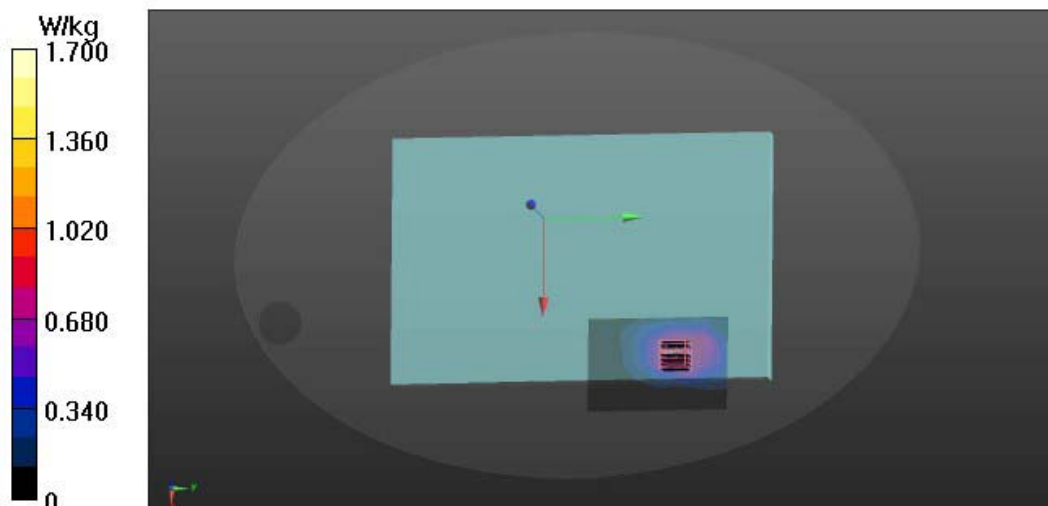

Date: 12/18/2019

Test Laboratory: Audix_SAR Lab

P11 802.11a CH54 5260MHz Ant B

DUT: 14Z995

Communication System: UID 0, WIFI 5G 802.11a (0); Frequency: 5260 MHz; Duty Cycle: 1:1

Medium parameters used: $f = 5260$ MHz, $\sigma = 5.502$ S/m, $\epsilon_r = 47.617$; $\rho = 1000$ kg/m³

Phantom section: Flat Section

DASY Configuration:

- Probe: EX3DV4 - SN3855; ConvF(4.44, 4.44, 4.44); Calibrated: 9/26/2019;
- Sensor-Surface: 2mm (Mechanical Surface Detection), $z = 1.0, 31.0$
- Electronics: DAE4 Sn1337; Calibrated: 9/18/2019
- Phantom: ELI v5.0; Type: QDOVA002AA; Serial: TP:1170
- DASY52 52.8.8(1258); SEMCAD X 14.6.10(7373)

Area Scan (9x13x1): Measurement grid: $dx=10$ mm, $dy=10$ mm

Maximum value of SAR (measured) = 0.971 W/kg

Zoom Scan (7x7x9)/Cube 0: Measurement grid: $dx=4$ mm, $dy=4$ mm, $dz=2.5$ mm

Reference Value = 0.6940 V/m; Power Drift = 1.20 dB

Peak SAR (extrapolated) = 3.49 W/kg

SAR(1 g) = 0.879 W/kg; SAR(10 g) = 0.304 W/kg

Maximum value of SAR (measured) = 1.59 W/kg

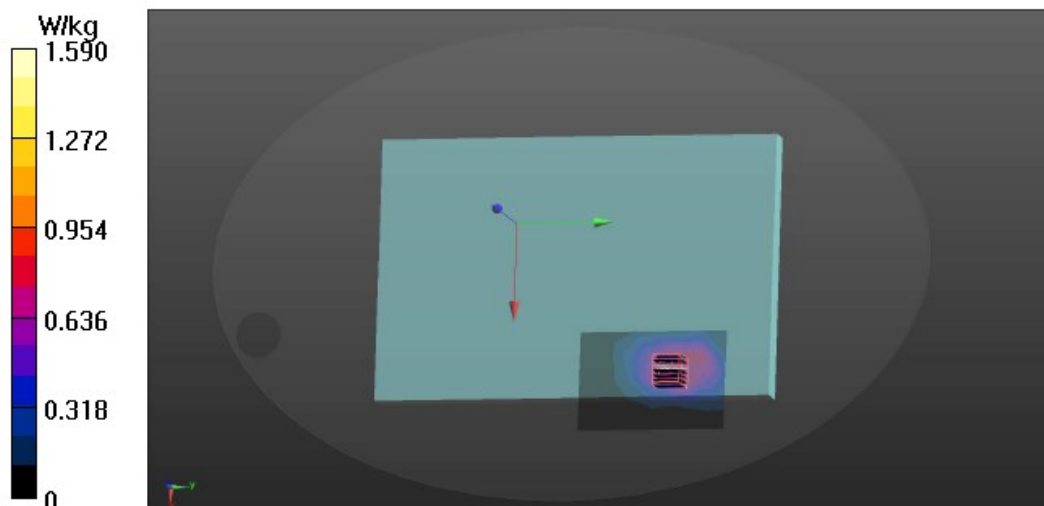

Date: 12/18/2019

Test Laboratory: Audix_SAR Lab

P14 802.11a CH48 5240MHz Ant A**DUT: 14Z995**

Communication System: UID 0, WIFI 5G 802.11a (0); Frequency: 5240 MHz; Duty Cycle: 1:1

Medium parameters used: $f = 5240$ MHz; $\sigma = 5.477$ S/m; $\epsilon_r = 47.658$; $\rho = 1000$ kg/m³

Phantom section: Flat Section

DASY Configuration:

- Probe: EX3DV4 - SN3855; ConvF(4.56, 4.56, 4.56); Calibrated: 9/26/2019;
- Sensor-Surface: 2mm (Mechanical Surface Detection), $z = 1.0, 31.0$
- Electronics: DAE4 Sn1337; Calibrated: 9/18/2019
- Phantom: ELI v5.0; Type: QDOVA002AA; Serial: TP:1170
- DASY52 52.8.8(1258); SEMCAD X 14.6.10(7373)

Area Scan (7x13x1): Measurement grid: $dx=10$ mm, $dy=10$ mm

Maximum value of SAR (measured) = 0.941 W/kg

Zoom Scan (7x7x9)/Cube 0: Measurement grid: $dx=4$ mm, $dy=4$ mm, $dz=2.5$ mm

Reference Value = 0.5750 V/m; Power Drift = -0.31 dB

Peak SAR (extrapolated) = 2.12 W/kg

SAR(1 g) = 0.637 W/kg; SAR(10 g) = 0.162 W/kg

Maximum value of SAR (measured) = 1.28 W/kg

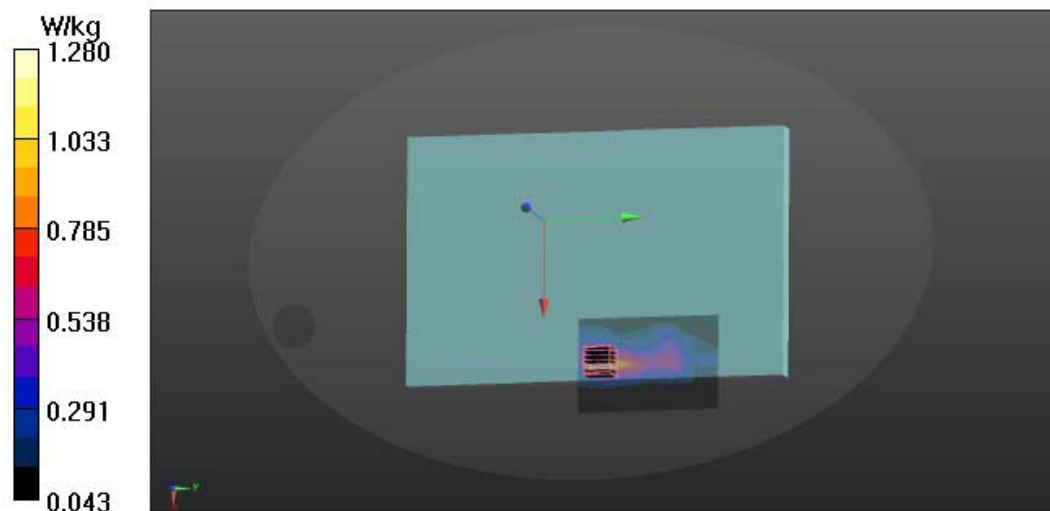

Date: 12/18/2019

Test Laboratory: Audix_SAR Lab

P1 802.11a CH52 5260MHz Ant A

DUT: 14Z995

Communication System: UID 0, WIFI 5G 802.11a (0); Frequency: 5260 MHz; Duty Cycle: 1:1

Medium parameters used: $f = 5260$ MHz; $\sigma = 5.502$ S/m; $\epsilon_r = 47.617$; $\rho = 1000$ kg/m³

Phantom section: Flat Section

DASY Configuration:

- Probe: EX3DV4 - SN3855; ConvF(4.44, 4.44, 4.44); Calibrated: 9/26/2019;
- Sensor-Surface: 2mm (Mechanical Surface Detection), $z = 1.0, 31.0$
- Electronics: DAE4 Sn1337; Calibrated: 9/18/2019
- Phantom: ELI v5.0; Type: QDOVA002AA; Serial: TP:1170
- DASY52 52.8.8(1258); SEMCAD X 14.6.10(7373)

Area Scan (9x13x1): Measurement grid: $dx=10$ mm, $dy=10$ mm

Maximum value of SAR (measured) = 0.946 W/kg

Zoom Scan (7x7x9)/Cube 0: Measurement grid: $dx=4$ mm, $dy=4$ mm, $dz=2.5$ mm

Reference Value = 0.6840 V/m; Power Drift = -0.05 dB

Peak SAR (extrapolated) = 2.37 W/kg

SAR(1 g) = 0.654 W/kg; SAR(10 g) = 0.186 W/kg

Maximum value of SAR (measured) = 1.33 W/kg

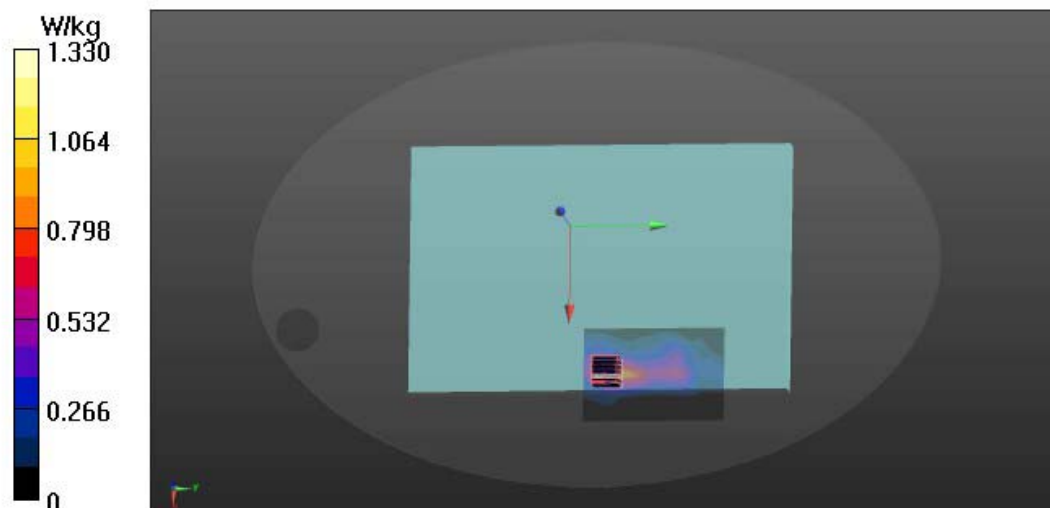

Date: 12/19/2019

Test Laboratory: Audix_SAR Lab

P17 802.11a CH100 5500MHz Ant B**DUT: 14Z995**

Communication System: UID 0, WIFI 5G 802.11a (0); Frequency: 5500 MHz; Duty Cycle: 1:1

Medium parameters used: $f = 5500$ MHz; $\sigma = 5.843$ S/m; $\epsilon_r = 47.111$; $\rho = 1000$ kg/m³

Phantom section: Flat Section

DASY Configuration:

- Probe: EX3DV4 - SN3855; ConvF(4.19, 4.19, 4.19); Calibrated: 9/26/2019;
- Sensor-Surface: 2mm (Mechanical Surface Detection), $z = 1.0, 31.0$
- Electronics: DAE4 Sn1337; Calibrated: 9/18/2019
- Phantom: ELI v5.0; Type: QDOVA002AA; Serial: TP:1170
- DASY52 52.8.8(1258); SEMCAD X 14.6.10(7373)

Area Scan (7x13x1): Measurement grid: $dx=10$ mm, $dy=10$ mm

Maximum value of SAR (measured) = 1.82 W/kg

Zoom Scan (7x7x9)/Cube 0: Measurement grid: $dx=4$ mm, $dy=4$ mm, $dz=2.5$ mm

Reference Value = 1.394 V/m; Power Drift = 1.03 dB

Peak SAR (extrapolated) = 3.56 W/kg

SAR(1 g) = 0.945 W/kg; SAR(10 g) = 0.361 W/kg

Maximum value of SAR (measured) = 1.88 W/kg

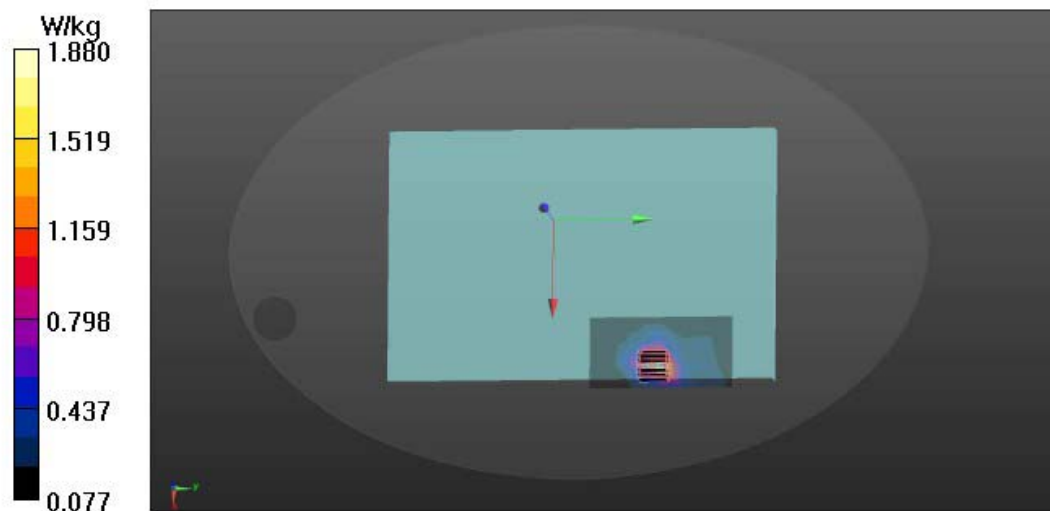

Date: 1/17/2020

Test Laboratory: Audix_SAR Lab

P22 802.11a CH100 5500MHz Ant B

DUT: 14Z995

Communication System: UID 0, WIFI 5G 802.11a (0); Frequency: 5500 MHz; Duty Cycle: 1:1

Medium parameters used: $f = 5500$ MHz, $\sigma = 5.853$ S/m, $\epsilon_r = 47.124$; $\rho = 1000$ kg/m³

Phantom section: Flat Section

DASY Configuration:

- Probe: EX3DV4 - SN3855; ConvF(4.19, 4.19, 4.19); Calibrated: 9/26/2019;
- Sensor-Surface: 2mm (Mechanical Surface Detection), $z = 1.0, 31.0$
- Electronics: DAE4 Sn1337; Calibrated: 9/18/2019
- Phantom: ELI v5.0; Type: QDOVA002AA; Serial: TP:1170
- DASY52 52.8.8(1258); SEMCAD X 14.6.10(7373)

Area Scan (7x13x1): Measurement grid: $dx=10$ mm, $dy=10$ mm

Maximum value of SAR (measured) = 1.82 W/kg

Zoom Scan (7x7x9)/Cube 0: Measurement grid: $dx=4$ mm, $dy=4$ mm, $dz=2.5$ mm

Reference Value = 0.8290 V/m; Power Drift = 0.58 dB

Peak SAR (extrapolated) = 3.56 W/kg

SAR(1 g) = 0.963 W/kg; SAR(10 g) = 0.342 W/kg

Maximum value of SAR (measured) = 1.93 W/kg

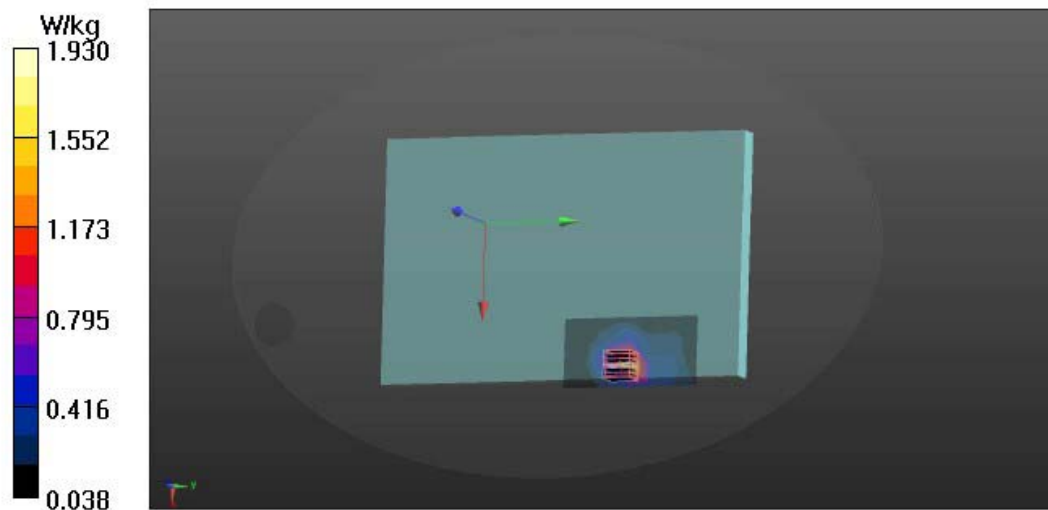

Date: 12/19/2019

Test Laboratory: Audix_SAR Lab

P4 802.11a CH116 5580MHz Ant B**DUT: 14Z995**

Communication System: UID 0, WIFI 5G 802.11a (0); Frequency: 5580 MHz; Duty Cycle: 1:1

Medium parameters used: $f = 5580$ MHz; $\sigma = 5.949$ S/m; $\epsilon_r = 46.958$; $\rho = 1000$ kg/m³

Phantom section: Flat Section

DASY Configuration:

- Probe: EX3DV4 - SN3855; ConvF(4.12, 4.12, 4.12); Calibrated: 9/26/2019;
- Sensor-Surface: 2mm (Mechanical Surface Detection), $z = 1.0, 31.0$
- Electronics: DAE4 Sn1337; Calibrated: 9/18/2019
- Phantom: ELI v5.0; Type: QDOVA002AA; Serial: TP:1170
- DASY52 52.10.0(1446); SEMCAD X 14.6.10(7417)

Area Scan (7x13x1): Measurement grid: $dx=10$ mm, $dy=10$ mm

Maximum value of SAR (measured) = 1.93 W/kg

Zoom Scan (7x7x9)/Cube 0: Measurement grid: $dx=4$ mm, $dy=4$ mm, $dz=2.5$ mm

Reference Value = 1.641 V/m; Power Drift = 1.05 dB

Peak SAR (extrapolated) = 3.66 W/kg

SAR(1 g) = 1.07 W/kg; SAR(10 g) = 0.405 W/kg

Maximum value of SAR (measured) = 1.98 W/kg

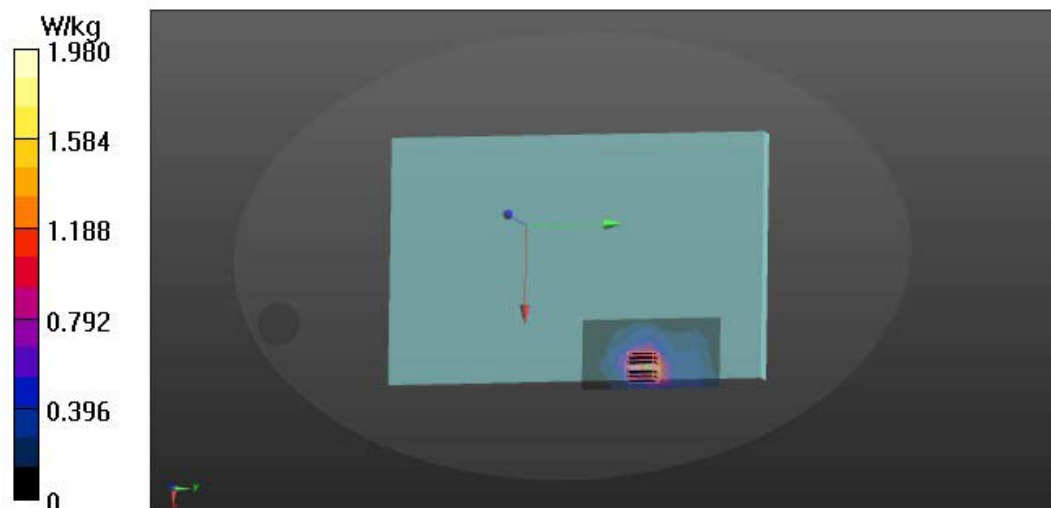

Date: 12/19/2019

Test Laboratory: Audix_SAR Lab

P12 802.11a CH116 5580MHz Ant B

DUT: 14Z995

Communication System: UID 0, WIFI 5G 802.11a (0); Frequency: 5580 MHz; Duty Cycle: 1:1

Medium parameters used: $f = 5580$ MHz; $\sigma = 5.949$ S/m; $\epsilon_r = 46.958$; $\rho = 1000$ kg/m³

Phantom section: Flat Section

DASY Configuration:

- Probe: EX3DV4 - SN3855; ConvF(4.12, 4.12, 4.12); Calibrated: 9/26/2019;
- Sensor-Surface: 2mm (Mechanical Surface Detection), $z = 1.0, 31.0$
- Electronics: DAE4 Sn1337; Calibrated: 9/18/2019
- Phantom: ELI v5.0; Type: QDOVA002AA; Serial: TP:1170
- DASY52 52.10.0(1446); SEMCAD X 14.6.10(7373)

Area Scan (7x13x1): Measurement grid: $dx=10$ mm, $dy=10$ mm

Maximum value of SAR (measured) = 1.85 W/kg

Zoom Scan (7x7x9)/Cube 0: Measurement grid: $dx=4$ mm, $dy=4$ mm, $dz=2.5$ mm

Reference Value = 1.652 V/m; Power Drift = 0.24 dB

Peak SAR (extrapolated) = 3.78 W/kg

SAR(1 g) = 1.09 W/kg; SAR(10 g) = 0.410 W/kg

Maximum value of SAR (measured) = 2.23 W/kg

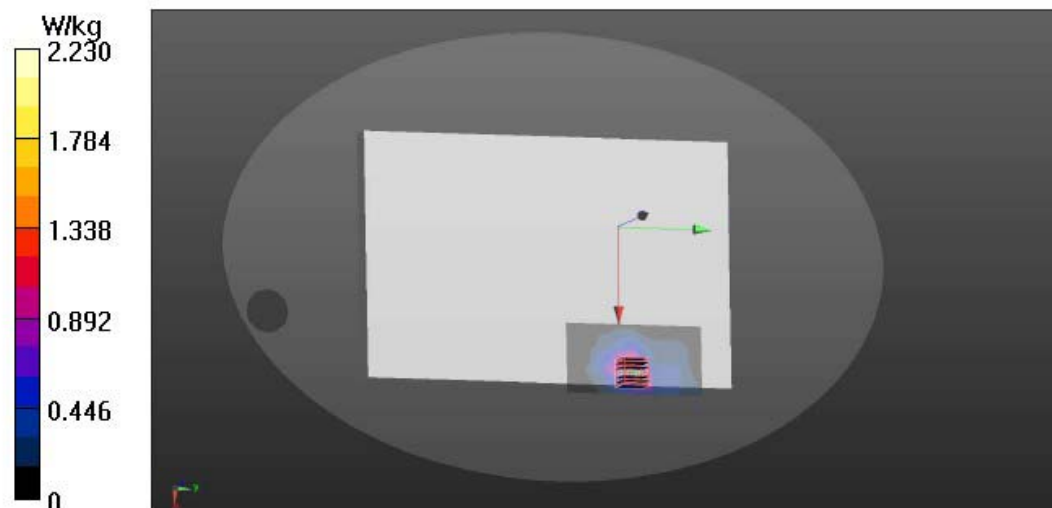

Date: 12/19/2019

Test Laboratory: Audix_SAR Lab

P16 802.11a CH100 5500MHz Ant A**DUT: 14Z995**

Communication System: UID 0, WIFI 5G 802.11a (0); Frequency: 5500 MHz; Duty Cycle: 1:1

Medium parameters used: $f = 5500$ MHz; $\sigma = 5.843$ S/m; $\epsilon_r = 47.111$; $\rho = 1000$ kg/m³

Phantom section: Flat Section

DASY Configuration:

- Probe: EX3DV4 - SN3855; ConvF(4.19, 4.19, 4.19); Calibrated: 9/26/2019;
- Sensor-Surface: 2mm (Mechanical Surface Detection), $z = 1.0, 31.0$
- Electronics: DAE4 Sn1337; Calibrated: 9/18/2019
- Phantom: ELI v5.0; Type: QDOVA002AA; Serial: TP:1170
- DASY52 52.8.8(1258); SEMCAD X 14.6.10(7373)

Area Scan (7x13x1): Measurement grid: $dx=10$ mm, $dy=10$ mm

Maximum value of SAR (measured) = 0.468 W/kg

Zoom Scan (7x7x9)/Cube 0: Measurement grid: $dx=4$ mm, $dy=4$ mm, $dz=2.5$ mm

Reference Value = 1.177 V/m; Power Drift = 0.91 dB

Peak SAR (extrapolated) = 2.57 W/kg

SAR(1 g) = 0.462 W/kg; SAR(10 g) = 0.208 W/kg

Maximum value of SAR (measured) = 1.01 W/kg

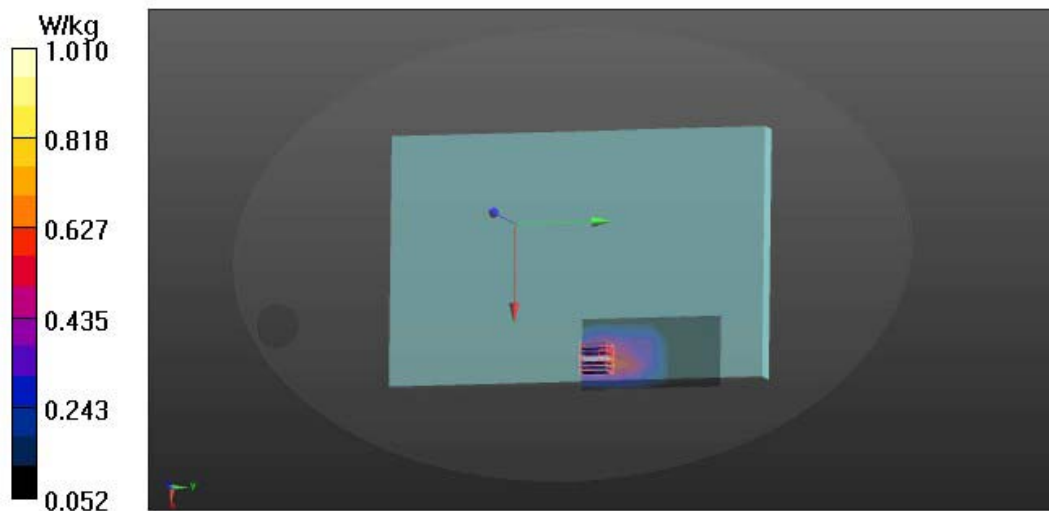

Date: 12/19/2019

Test Laboratory: Audix_SAR Lab

P3 802.11a CH116 5580MHz Ant A

DUT: 14Z995

Communication System: UID 0, WIFI 5G 802.11a (0); Frequency: 5580 MHz; Duty Cycle: 1:1

Medium parameters used: $f = 5580$ MHz; $\sigma = 5.949$ S/m; $\epsilon_r = 46.958$; $\rho = 1000$ kg/m³

Phantom section: Flat Section

DASY Configuration:

- Probe: EX3DV4 - SN3855; ConvF(4.12, 4.12, 4.12); Calibrated: 9/26/2019;
- Sensor-Surface: 2mm (Mechanical Surface Detection), $z = 1.0, 31.0$
- Electronics: DAE4 Sn1337; Calibrated: 9/18/2019
- Phantom: ELI v5.0; Type: QDOVA002AA; Serial: TP:1170
- DASY52 52.8.8(1258); SEMCAD X 14.6.10(7417)

Area Scan (7x13x1): Measurement grid: $dx=10$ mm, $dy=10$ mm

Maximum value of SAR (measured) = 0.486 W/kg

Zoom Scan (7x7x9)/Cube 0: Measurement grid: $dx=4$ mm, $dy=4$ mm, $dz=2.5$ mm

Reference Value = 1.354 V/m; Power Drift = 0.72 dB

Peak SAR (extrapolated) = 2.04 W/kg

SAR(1 g) = 0.475 W/kg; SAR(10 g) = 0.216 W/kg

Maximum value of SAR (measured) = 1.07 W/kg

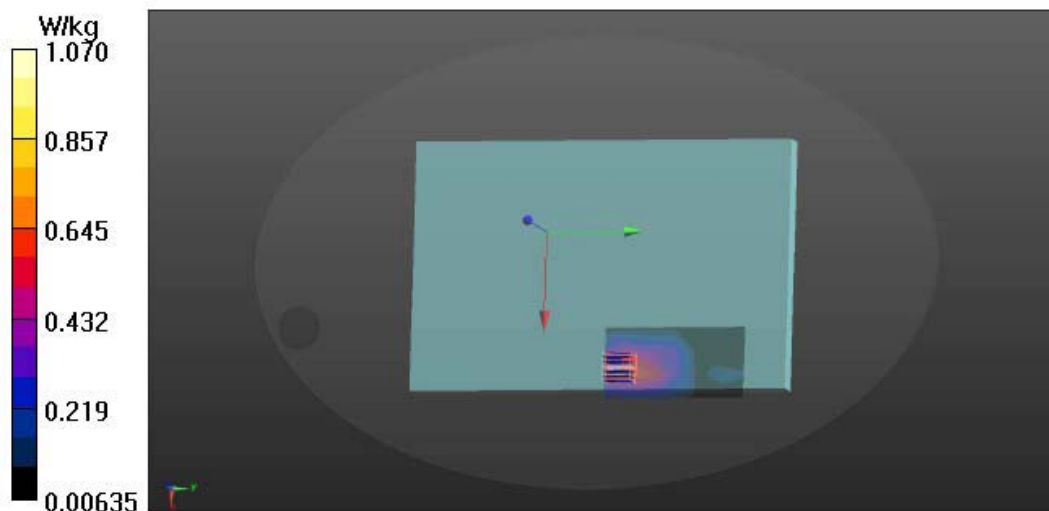

Date: 12/20/2019

Test Laboratory: Audix_SAR Lab

P6 802.11a CH149 5745MHz Ant B

DUT: 14Z995

Communication System: UID 0, WIFI 5G 802.11a (0); Frequency: 5745 MHz; Duty Cycle: 1:1

Medium parameters used: $f = 5745$ MHz, $\sigma = 6.195$ S/m, $\epsilon_r = 46.656$, $\rho = 1000$ kg/m³

Phantom section: Flat Section

DASY Configuration:

- Probe: EX3DV4 - SN3855; ConvF(4.18, 4.18, 4.18); Calibrated: 9/26/2019;
- Sensor-Surface: 2mm (Mechanical Surface Detection), $z = 1.0, 31.0$
- Electronics: DAE4 Sn1337; Calibrated: 9/18/2019
- Phantom: ELI v5.0; Type: QDOVA002AA; Serial: TP:1170
- DASY52 52.8.8(1258); SEMCAD X 14.6.10(7417)

Area Scan (7x13x1): Measurement grid: $dx=10$ mm, $dy=10$ mm

Maximum value of SAR (measured) = 1.32 W/kg

Zoom Scan (7x7x9)/Cube 0: Measurement grid: $dx=4$ mm, $dy=4$ mm, $dz=2.5$ mm

Reference Value = 1.992 V/m; Power Drift = 1.85 dB

Peak SAR (extrapolated) = 4.33 W/kg

SAR(1 g) = 1.11 W/kg; SAR(10 g) = 0.457 W/kg

Maximum value of SAR (measured) = 2.09 W/kg

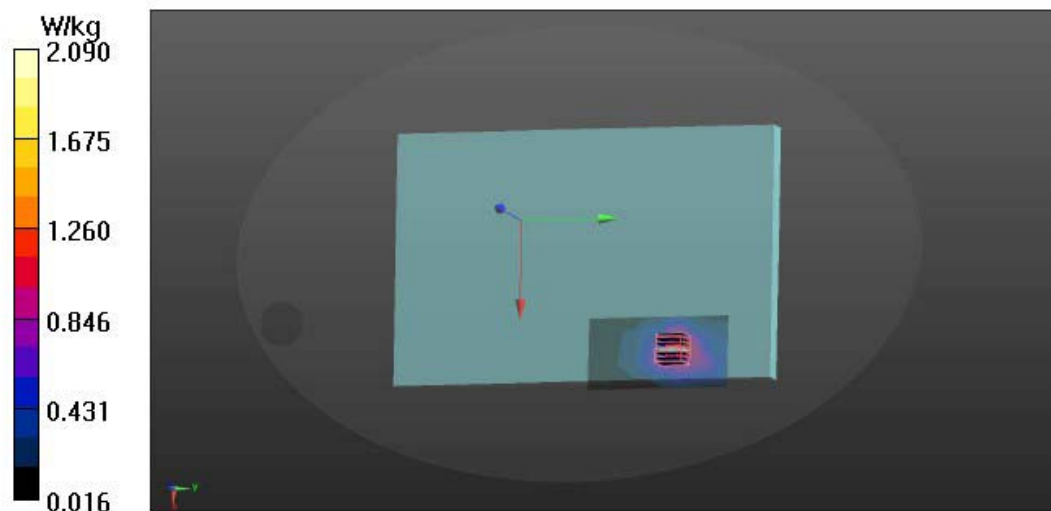

Date: 12/20/2019

Test Laboratory: Audix_SAR Lab

P13 802.11a CH149 5745MHz Ant B

DUT: 14Z995

Communication System: UID 0, WIFI 5G 802.11a (0); Frequency: 5745 MHz; Duty Cycle: 1:1

Medium parameters used: $f = 5745$ MHz; $\sigma = 6.195$ S/m; $\epsilon_r = 46.656$; $\rho = 1000$ kg/m³

Phantom section: Flat Section

DASY Configuration:

- Probe: EX3DV4 - SN3855; ConvF(4.18, 4.18, 4.18); Calibrated: 9/26/2019;
- Sensor-Surface: 2mm (Mechanical Surface Detection), $z = 1.0, 31.0$
- Electronics: DAE4 Sn1337; Calibrated: 9/18/2019
- Phantom: ELI v5.0; Type: QDOVA002AA; Serial: TP:1170
- DASY52 52.8.8(1258); SEMCAD X 14.6.10(7373)

Area Scan (7x13x1): Measurement grid: $dx=10$ mm, $dy=10$ mm

Maximum value of SAR (measured) = 1.25 W/kg

Zoom Scan (7x7x9)/Cube 0: Measurement grid: $dx=4$ mm, $dy=4$ mm, $dz=2.5$ mm

Reference Value = 1.165 V/m; Power Drift = 1.82 dB

Peak SAR (extrapolated) = 4.07 W/kg

SAR(1 g) = 1.03 W/kg; SAR(10 g) = 0.448 W/kg

Maximum value of SAR (measured) = 1.84 W/kg

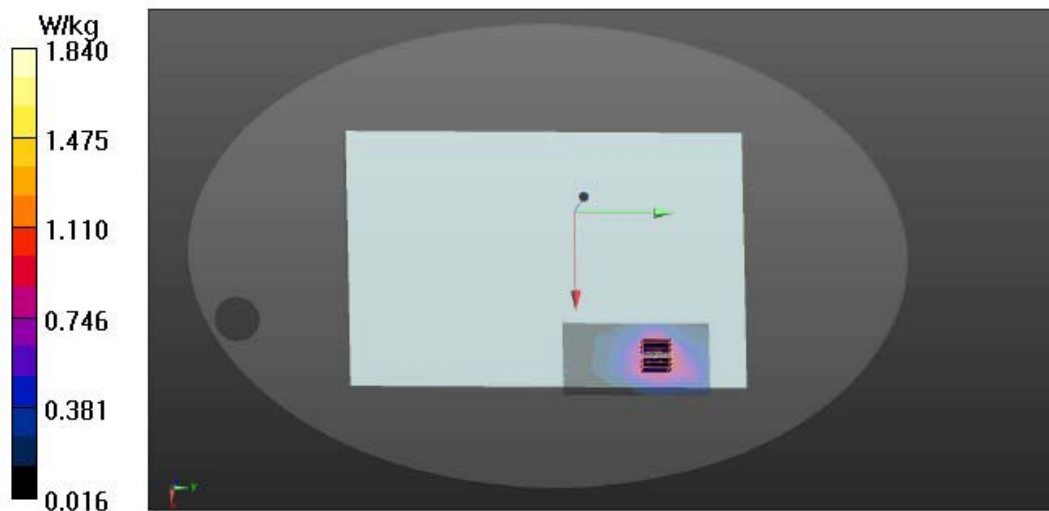

Date: 12/20/2019

Test Laboratory: Audix_SAR Lab

P19 802.11a CH157 5785MHz Ant B

DUT: 14Z995

Communication System: UID 0, WIFI 5G 802.11a (0); Frequency: 5785 MHz; Duty Cycle: 1:1

Medium parameters used: $f = 5785$ MHz; $\sigma = 6.24$ S/m; $\epsilon_r = 46.578$; $\rho = 1000$ kg/m³

Phantom section: Flat Section

DASY Configuration:

- Probe: EX3DV4 - SN3855; ConvF(4.18, 4.18, 4.18); Calibrated: 9/26/2019;
- Sensor-Surface: 2mm (Mechanical Surface Detection), $z = 1.0, 31.0$
- Electronics: DAE4 Sn1337; Calibrated: 9/18/2019
- Phantom: ELI v5.0; Type: QDOVA002AA; Serial: TP:1170
- DASY52 52.8.8(1258); SEMCAD X 14.6.10(7373)

Area Scan (7x13x1): Measurement grid: $dx=10$ mm, $dy=10$ mm

Maximum value of SAR (measured) = 1.26 W/kg

Zoom Scan (7x7x9)/Cube 0: Measurement grid: $dx=4$ mm, $dy=4$ mm, $dz=2.5$ mm

Reference Value = 1.655 V/m; Power Drift = 1.74 dB

Peak SAR (extrapolated) = 4.30 W/kg

SAR(1 g) = 0.994 W/kg; SAR(10 g) = 0.422 W/kg

Maximum value of SAR (measured) = 1.92 W/kg

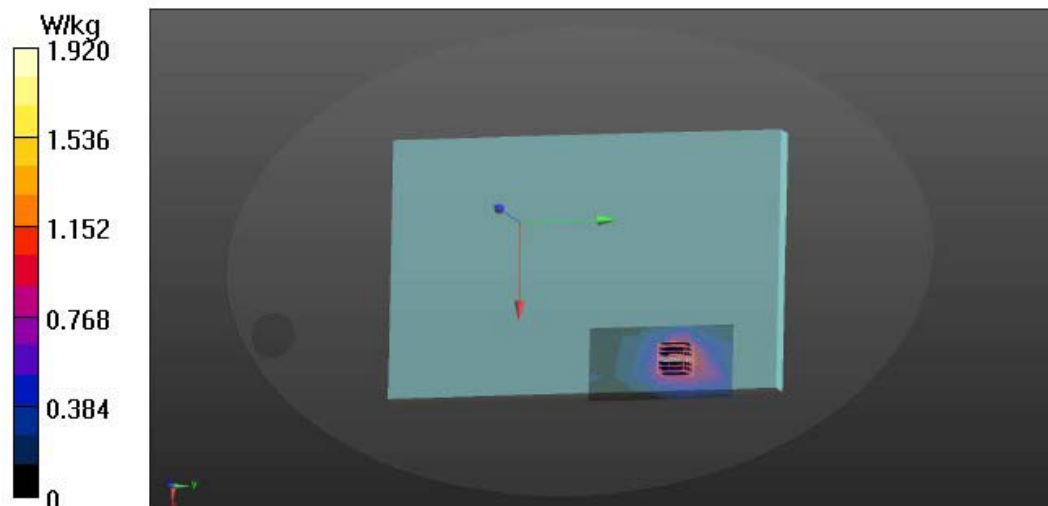

Date: 1/17/2020

Test Laboratory: Audix_SAR Lab

P23 802.11a CH157 5785MHz Ant B

DUT: 14Z995

Communication System: UID 0, WIFI 5G 802.11a (0); Frequency: 5785 MHz; Duty Cycle: 1:1

Medium parameters used: $f = 5785$ MHz, $\sigma = 6.25$ S/m; $\epsilon_r = 46.59$; $\rho = 1000$ kg/m³

Phantom section: Flat Section

DASY Configuration:

- Probe: EX3DV4 - SN3855; ConvF(4.18, 4.18, 4.18); Calibrated: 9/26/2019;
- Sensor-Surface: 2mm (Mechanical Surface Detection), $z = 1.0, 31.0$
- Electronics: DAE4 Sn1337; Calibrated: 9/18/2019
- Phantom: ELI v5.0; Type: QDOVA002AA; Serial: TP:1170
- DASY52 52.8.8(1258); SEMCAD X 14.6.10(7373)

Area Scan (7x13x1): Measurement grid: $dx=10$ mm, $dy=10$ mm

Maximum value of SAR (measured) = 1.35 W/kg

Zoom Scan (7x7x9)/Cube 0: Measurement grid: $dx=4$ mm, $dy=4$ mm, $dz=2.5$ mm

Reference Value = 1.692 V/m; Power Drift = 1.92 dB

Peak SAR (extrapolated) = 4.43 W/kg

SAR(1 g) = 1.03 W/kg; SAR(10 g) = 0.467 W/kg

Maximum value of SAR (measured) = 2.14 W/kg

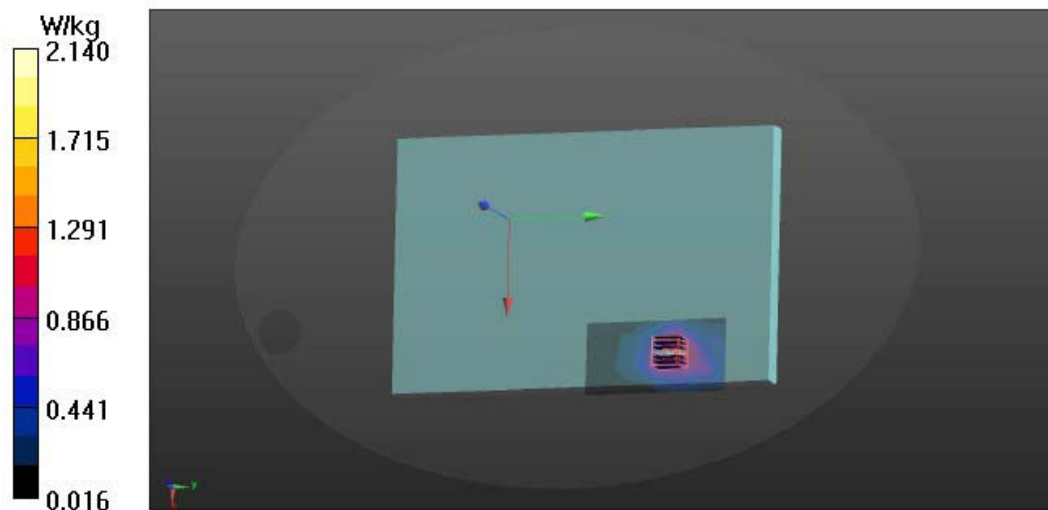

Date: 12/20/2019

Test Laboratory: Audix_SAR Lab

P5 802.11a CH149 5745MHz Ant A

DUT: 14Z995

Communication System: UID 0, WIFI 5G 802.11a (0); Frequency: 5745 MHz; Duty Cycle: 1:1

Medium parameters used: $f = 5745$ MHz, $\sigma = 6.195$ S/m, $\epsilon_r = 46.656$; $\rho = 1000$ kg/m³

Phantom section: Flat Section

DASY Configuration:

- Probe: EX3DV4 - SN3855; ConvF(4.18, 4.18, 4.18); Calibrated: 9/26/2019;
- Sensor-Surface: 2mm (Mechanical Surface Detection), $z = 1.0, 31.0$
- Electronics: DAE4 Sn1337; Calibrated: 9/18/2019
- Phantom: ELI v5.0; Type: QDOVA002AA; Serial: TP:1170
- DASY52 52.8.8(1258); SEMCAD X 14.6.10(7417)

Area Scan (7x17x1): Measurement grid: $dx=10$ mm, $dy=10$ mm

Maximum value of SAR (measured) = 0.697 W/kg

Zoom Scan (7x7x9)/Cube 0: Measurement grid: $dx=4$ mm, $dy=4$ mm, $dz=2.5$ mm

Reference Value = 0.6820 V/m; Power Drift = 1.20 dB

Peak SAR (extrapolated) = 1.49 W/kg

SAR(1 g) = 0.364 W/kg; SAR(10 g) = 0.141 W/kg

Maximum value of SAR (measured) = 0.765 W/kg

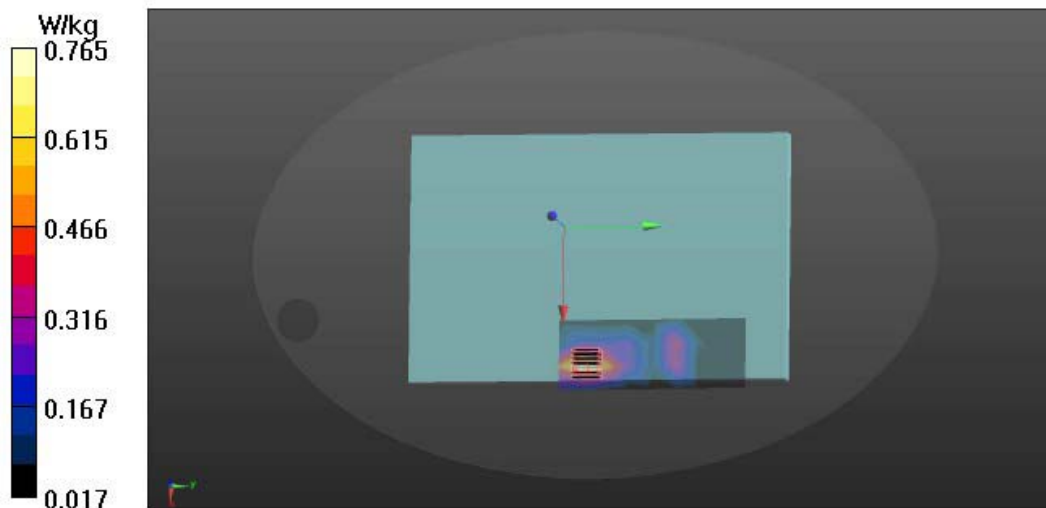

Date: 12/20/2019

Test Laboratory: Audix_SAR Lab

P18 802.11a CH157 5785MHz Ant A

DUT: 14Z995

Communication System: UID 0, WIFI 5G 802.11a (0); Frequency: 5785 MHz; Duty Cycle: 1:1

Medium parameters used: $f = 5785$ MHz, $\sigma = 6.24$ S/m; $\epsilon_r = 46.578$; $\rho = 1000$ kg/m³

Phantom section: Flat Section

DASY Configuration:

- Probe: EX3DV4 - SN3855; ConvF(4.18, 4.18, 4.18); Calibrated: 9/26/2019;
- Sensor-Surface: 2mm (Mechanical Surface Detection), $z = 1.0, 31.0$
- Electronics: DAE4 Sn1337; Calibrated: 9/18/2019
- Phantom: ELI v5.0; Type: QDOVA002AA; Serial: TP:1170
- DASY52 52.8.8(1258); SEMCAD X 14.6.10(7373)

Area Scan (7x17x1): Measurement grid: $dx=10$ mm, $dy=10$ mm

Maximum value of SAR (measured) = 0.701 W/kg

Zoom Scan (7x7x9)/Cube 0: Measurement grid: $dx=4$ mm, $dy=4$ mm, $dz=2.5$ mm

Reference Value = 0.5910 V/m; Power Drift = 1.46 dB

Peak SAR (extrapolated) = 1.38 W/kg

SAR(1 g) = 0.345 W/kg; SAR(10 g) = 0.133 W/kg

Maximum value of SAR (measured) = 0.749 W/kg

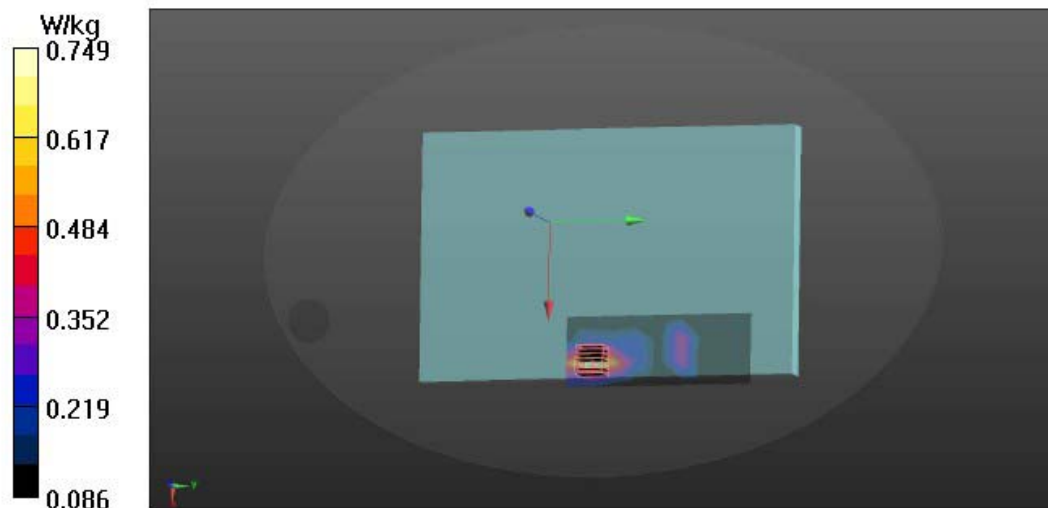

Date: 12/23/2019

Test Laboratory: Audix_SAR Lab

P9 GFSK CH39 2441MHz

DUT: 14Z995

Communication System: UID 0, BT (0); Frequency: 2441 MHz; Duty Cycle: 1:1.3
Medium parameters used: $f = 2441$ MHz, $\sigma = 1.972$ S/m, $\epsilon_r = 51.463$, $\rho = 1000$ kg/m³
Phantom section: Flat Section

DASY Configuration:

- Probe: EX3DV4 - SN3855; ConvF(7.63, 7.63, 7.63); Calibrated: 9/26/2019;
- Sensor-Surface: 2mm (Mechanical Surface Detection), $z = 1.0, 31.0$
- Electronics: DAE4 Sn1337; Calibrated: 9/18/2019
- Phantom: ELI v5.0; Type: QDOVA002AA; Serial: TP:1170
- DASY52 52.8.8(1258); SEMCAD X 14.6.10(7373)

Area Scan (4x7x1): Measurement grid: $dx=20$ mm, $dy=20$ mm
Maximum value of SAR (measured) = 0.0187 W/kg

Zoom Scan (5x5x7)/Cube 0: Measurement grid: $dx=8$ mm, $dy=8$ mm, $dz=5$ mm
Reference Value = 1.181 V/m; Power Drift = 1.55 dB
Peak SAR (extrapolated) = 0.0290 W/kg
SAR(1 g) = 0.015 W/kg; SAR(10 g) = 0.012 W/kg
Maximum value of SAR (measured) = 0.0191 W/kg

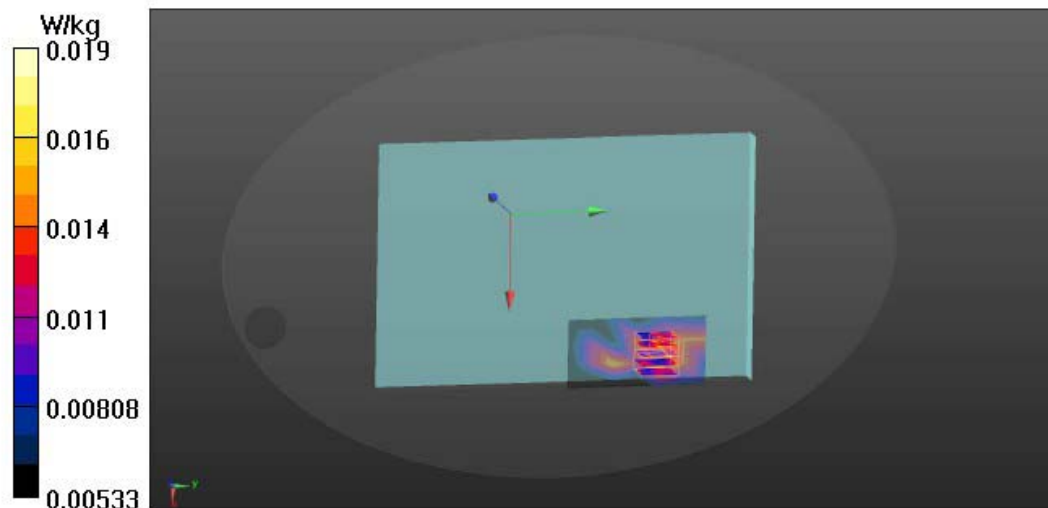



Audix Technology Corp.
No. 53-11, Dingfu, Linkou, Dist.,
New Taipei City 244, Taiwan

APPENDIX B

Tel: +886 2 26099301
Fax: +886 2 26099303

APPENDIX B

TEST PHOTOGRAPHS

(Model: 14Z995)



*Audix Technology Corp.
No. 53-11, Dingfu, Linkou, Dist.,
New Taipei City 244, Taiwan*

*Tel: +886 2 26099301
Fax: +886 2 26099303*

APPENDIX C

Test Equipment Calibration Data