



# WA-F-LBLB-04-057 Specification

## 1. Explanation of part number :

WA - F - LBLB - 04 - 057  
(1) (2) (3) (4) (5)

(1) Product Type: Wireless Antenna

(2) PCB: FPCB

(3) Frequency : 2.4GHz&5GHz

(4) Coaxial Cable Type : With  $\phi$  0.81 Black ,  $\phi$  0.81 Gray

(5) Suffix : 057

## 2. Storage Condition:

Temperature -40 to +70°C  
Humidity 20 to 65 %RH

## 3. Operating Condition:

Temperature -40 to +70°C  
Humidity 10 to 85 %RH

## 4. Electrical Specification :

*Those specifications were specially defined for LG 13Z980 WIFI model, and all characteristics were measured under the model's handset testing jig .*

### 4-1. Frequency Band:

Frequency Band	MHz
WIFI\BT	2400-2500 5100-5800

UNLESS OTHER SPECIFIED TOLERANCES ON:

X=± X.X=± X.XX=±

ANGLES=± HOLEDIA=±

SCALE: UNIT: mm

DRAWN BY: 林娟 CHECKED BY:李志强

DESIGNED BY: 胡志清 APPROVED BY: 唐龙

TITLE: WA-F-LBLB-04-057 Specification



佳邦科技股份有限公司  
INPAQ TECHNOLOGY CO., LTD.

THIS DRAWINGS AND SPECIFICATIONS ARE THE PROPERTY OF INPAQ TECHNOLOGY CO.,LTD.AND SHALL NOT BE REPRODUCED OR USED AS THE BASIS FOR THE MANUFACTURE OR SALE OF APPARATUS OR DEVICES WITHOUT PERMISSION

DOCUMENT NO.

ENS000104670

PAGE REV.  
A0

## 4-2. Impedance

50 ohm nominal

## 4-3. Matching circuit

None

## 4-4. VSWR

### 4-4.1 Measuring Method

1.A 50  $\Omega$  coaxial cable is connected to the antenna. Then this cable is connected to a network analyzer to measure the VSWR

2.Keeping this jig away from metal at least 20cm

### 4-4.2 Measurement frequency points and VSWR value

Frequency (Unit MHz)	2400	2500	5100	5800
VSWR	$\leq 3.5$		$\leq 5.5$	

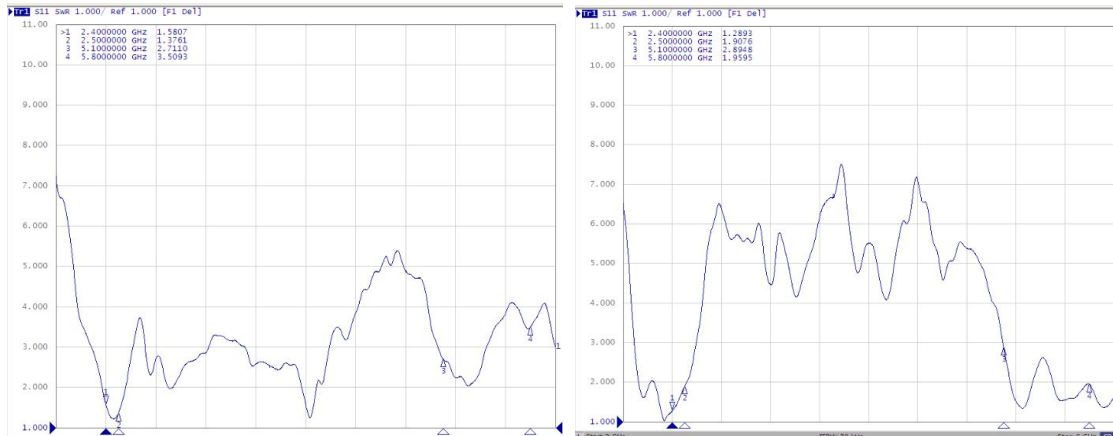

MAIN

AUX

## 4-5. Efficiency and Gain

### 4-5.1 Measure method

- Using a low loss coaxial cable to link a standard handset jig
- Fixed this handset jig on chamber's rotator plane
- Linking jig into network analyzer port and using a probing horn antenna to collect data.
- Using another standard gain horn antenna to calibrated those data

UNLESS OTHER SPECIFIED TOLERANCES ON:

X=±      X.X=±      X.XX=±

ANGLES=±      HOLEDIA=±

SCALE:      UNIT: mm

DRAWN BY: 林娟      CHECKED BY: 李志强

DESIGNED BY: 胡志清      APPROVED BY: 唐龙

TITLE: WA-F-LBLB-04-057 Specification



佳邦科技股份有限公司  
INPAQ TECHNOLOGY CO., LTD.

THIS DRAWINGS AND SPECIFICATIONS ARE THE PROPERTY OF INPAQ TECHNOLOGY CO.,LTD.AND SHALL NOT BE REPRODUCED OR USED AS THE BASIS FOR THE MANUFACTURE OR SALE OF APPARATUS OR DEVICES WITHOUT PERMISSION

DOCUMENT NO.

ENS000104670

PAGE REV.  
A0

## 4-5.2 Chamber definition

An anechoic chamber (8mx4mx3.5m) which satisfied far-field condition was applied to avoid multi-path effect

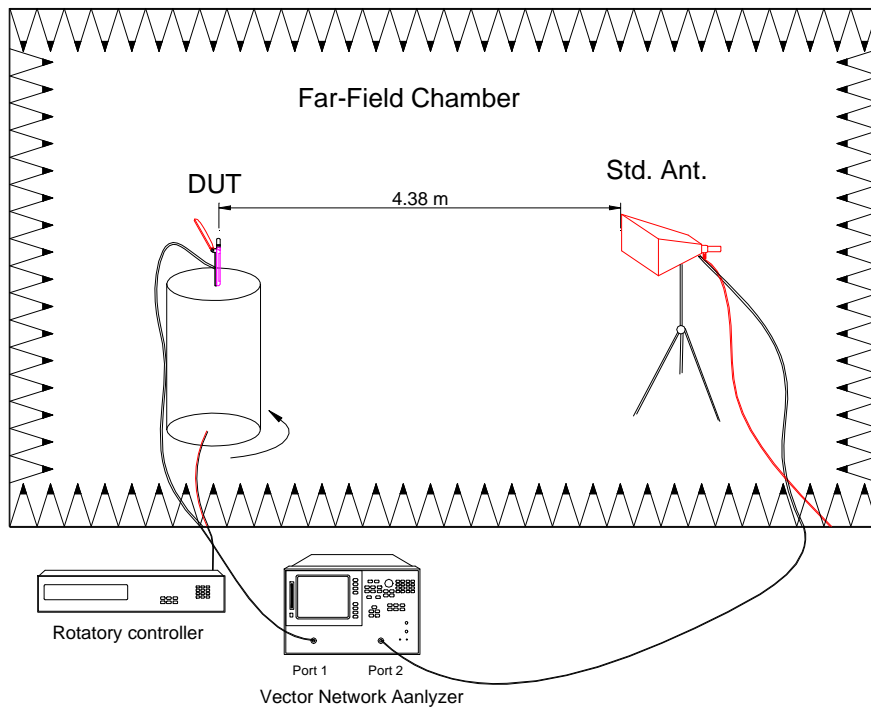

1. The quiet room region is 40cmx40cmx40cm at the center of rotator
2. The distance between DUT and standard antenna is 4.38 m
3. Probing antenna (9120D horn antenna) and standard gain horn antenna (BBHA9120 LPF 700MHz ~6GHz)

## 4-5.3 Efficiency and Gain

Antenna gain is marked (dBi) and is based on STANDARD HORN antenna. The data shows Peak Gain and Average Gain.

### 4-5-3-1 Electrical specification

Frequency (MHz)	Efficiency (%)
2400	>30
2450	>30
2500	>30
5100	>20
5400	>20
5800	>20

UNLESS OTHER SPECIFIED TOLERANCES ON:

X=±      X.X=±      X.XX=±

ANGLES=±      HOLEDIA=±

SCALE:      UNIT: mm

DRAWN BY: 林娟      CHECKED BY: 李志强

DESIGNED BY: 胡志清      APPROVED BY: 唐龙

TITLE: WA-F-LBLB-04-057 Specification



佳邦科技股份有限公司  
INPAQ TECHNOLOGY CO., LTD.

THIS DRAWINGS AND SPECIFICATIONS ARE THE PROPERTY OF INPAQ TECHNOLOGY CO.,LTD.AND SHALL NOT BE REPRODUCED OR USED AS THE BASIS FOR THE MANUFACTURE OR SALE OF APPARATUS OR DEVICES WITHOUT PERMISSION

DOCUMENT NO.

ENS000104670

PAGE REV.  
A0

### 4-5-3-2 Electrical specification

Frequency (MHz)	Main Antenna			AUX Antenna		
	AVG Gain(dB)	Efficiency (%)	Peak Gain (dBi)	AVG Gain(dB)	Efficiency (%)	Peak Gain (dBi)
2400	-4.30	37.19	2.58	-4.55	35.04	2.00
2450	-4.09	39.02	2.41	-4.02	39.63	2.91
2500	-4.49	35.54	2.11	-4.50	35.47	2.55
5100	-5.85	25.99	1.97	-5.77	26.46	1.03
5400	-5.42	28.71	1.70	-5.58	27.66	2.03
5800	-6.03	24.95	1.18	-6.25	23.71	1.34

## 5. Mechanical Specification:

Connector: I-PEX MHF 4: 20448; Cable: RF Cable0.81 Lowloss Black + Gray

### Mechanical Configuration:

ASSY Drawing (\* dimension is important dimension, the dimension without tolerance follow the tolerance list)

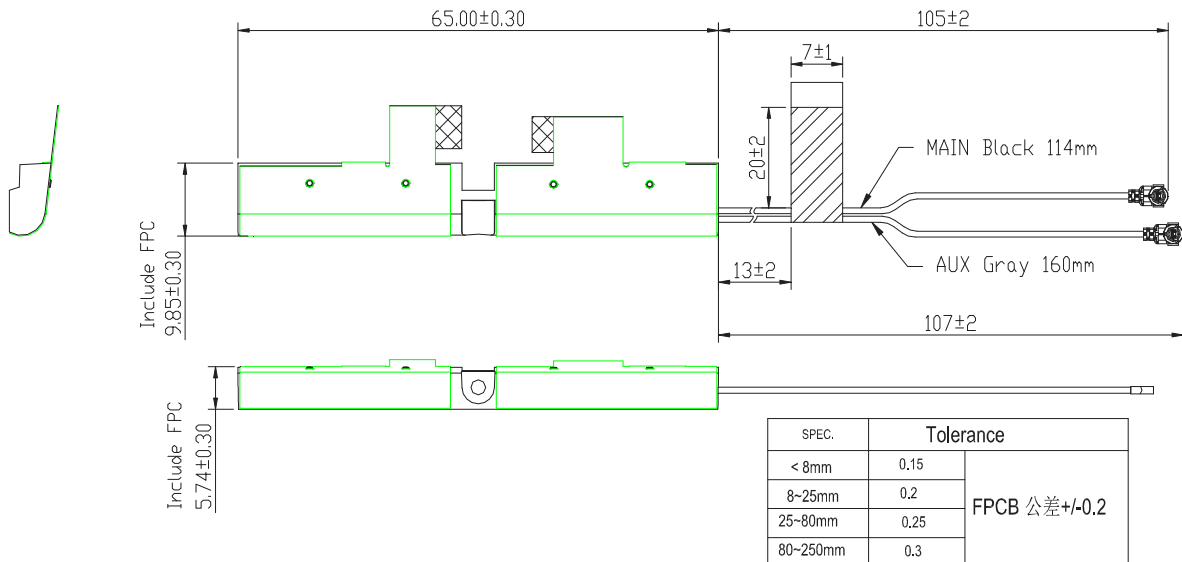

## 6. UL File No:

ITEM	DESCRIPTION	SUPPLIER	UL File No
1	FPCB	M00316	E358911
2	CABLE	M00018	E318898
		M00186	E464731

UNLESS OTHER SPECIFIED TOLERANCES ON:

X=±      X.X=±      X.XX=±

ANGLES=±      HOLEDIA=±

SCALE:      UNIT: mm

DRAWN BY: 林娟      CHECKED BY: 李志强

DESIGNED BY: 胡志清      APPROVED BY: 唐龙

TITLE: WA-F-LBLB-04-057 Specification



佳邦科技股份有限公司  
INPAQ TECHNOLOGY CO., LTD.

THIS DRAWINGS AND SPECIFICATIONS ARE THE PROPERTY OF INPAQ TECHNOLOGY CO.,LTD.AND SHALL NOT BE REPRODUCED OR USED AS THE BASIS FOR THE MANUFACTURE OR SALE OF APPARATUS OR DEVICES WITHOUT PERMISSION

DOCUMENT NO.

ENS000104670

PAGE REV.  
A0