

HCT CO., LTD.

CERTIFICATE OF COMPLIANCE FCC Certification

Applicant Name: LG Electronics Inc.	Date of Issue: November 14, 2012
Address: 19-1, Cheongho-ri, Jinwi-myeon, Pyeongtaek-si, Gyeonggi-do 451-713, Korea	Test Site/Location: HCT CO., LTD., 105-1, Jangam-ri, Majang-Myeon, Icheon-si, Kyunggi-Do, Korea
	Report No.: HCTR1210FR05-3
	HCT FRN: 0005866421

FCC ID: BEJLTTTC10N

APPLICANT: LG Electronics Inc.

FCC Model(s):	TC10AF3NU
EUT Type:	CDMA/GSM/WCDMA/LTE Telematics
FCC Classification:	PCS Licensed Transmitter (PCB)
FCC Rule Part(s):	§22, §24, §27, §2
Tx Frequency:	824.20 - 848.80 MHz (GSM850) 826.40 - 846.60 MHz (WCDMA850) 1 850.20 - 1 909.80 MHz (GSM1900) 1 852.4 - 1 907.6 MHz (WCDMA1900) 1 712.4 - 1 752.6 MHz (WCDMA1700)
Rx Frequency:	869.20 - 893.80 MHz (GSM850) 871.40 - 891.60 MHz (WCDMA850) 1 930.20 - 1 989.80 MHz (GSM1900) 1 932.4 - 1 987.6 MHz (WCDMA1900) 2 112.4 - 2 152.6 MHz (WCDMA1700)
Max. Conducted Power:	2.344 W GSM850 (33.70 dBm) / 1.062 W GSM1900 (30.26 dBm) 0.593 W EDGE850 (27.73 dBm) / 0.457 W EDGE1900 (26.60 dBm) 0.255 W WCDMA850 (24.06 dBm) / 0.243 W WCDMA1900 (23.86 dBm) 0.230 W WCDMA1700 (23.61 dBm)
Emission Designator(s):	245 KGXW (GSM850) 244 KGXW (GSM1900) 243 KG7W (GSM850 EDGE) 243 KG7W (GSM1900 EDGE) 4M17F9W (WCDMA850) 4M17F9W (WCDMA1900) 4M18F9W (WCDMA1700)

The measurements shown in this report were made in accordance with the procedures specified in §2.947. I assume full responsibility for the accuracy and completeness of these measurements, and for the qualifications of all persons taking them.

HCT CO., LTD. Certifies that no party to this application has subject to a denial of Federal benefits that includes FCC benefits pursuant to section 5301 of the Anti-Drug Abuse Act of 1998, 21 U.S. C.853(a)

Report prepared by
: Jae Chul Shin
Test engineer of RF Team

Approved by
: Sang Jun Lee
Manager of RF Team

This report only responds to the tested sample and may not be reproduced, except in full, without written approval of the HCT Co., Ltd.

FCC CERTIFICATION REPORT			www.hct.co.kr
Test Report No. HCTR1210FR05-3	Date of Issue: November 14, 2012	EUT Type: CDMA/GSM/WCDMA/LTE Telematics	FCC ID: BEJLTTTC10N

Version

TEST REPORT NO.	DATE	DESCRIPTION
HCTR1210FR05	October 05, 2012	First Approval Report
HCTR1210FR05-1	October 26, 2012	Corrected the ERP Sample calculation on page 14. Corrected the unit of the antenna gain and EIRP in section 7.7
HCTR1210FR05-2	November 01, 2012	Corrected the EUT type.
HCTR1210FR05-3	November 14, 2012	<ul style="list-style-type: none"> - Corrected the Max. RF Output Power on page 1 and 4. - Corrected the data values for the spurious emissions of GSM850 and WCDMA850 band on page 22, 24. - Added information about the plot offsets on page 9. - Added test data and plots for WCDMA 1700 (Band 4)

Table of Contents

1. GENERAL INFORMATION		4
2. INTRODUCTION		5
2.1. EUT DESCRIPTION.....		5
2.2. MEASURING INSTRUMENT CALIBRATION.....		5
2.3. TEST FACILITY		5
3. DESCRIPTION OF TESTS		6
3.1 EFFECTIVE RADIATED POWER/EQUIVALENT ISOTROPIC RADIATED POWER.....		6
3.2 PEAK- TO- AVERAGE RATIO		7
3.3 OCCUPIED BANDWIDTH.		8
3.4 SPURIOUS AND HARMONIC EMISSIONS AT ANTENNA TERMINAL.....		9
3.5 RADIATED SPURIOUS AND HARMONIC EMISSIONS		10
3.6 FREQUENCY STABILITY / VARIATION OF AMBIENT TEMPERATURE		11
4. LIST OF TEST EQUIPMENT		12
5. SUMMARY OF TEST RESULTS		13
6. SAMPLE CALCULATION		14
7. TEST DATA		15
7.1 CONDUCTED OUTPUT POWER.....		15
7.2 PEAK-TO-AVERAGE RATIO		18
7.3 OCCUPIED BANDWIDTH		18
7.4 CONDUCTED SPURIOUS EMISSIONS		19
7.4.1 BAND EDGE.....		19
7.5 EFFECTIVE RADIATED POWER OUTPUT (GSM / WCDMA)		20
7.6 EQUIVALENT ISOTROPIC RADIATED POWER (GSM / WCDMA).....		21
7.7 RADIATED SPURIOUS EMISSIONS		23
7.7.1 RADIATED SPURIOUS EMISSIONS (GSM850).....		23
7.7.2 RADIATED SPURIOUS EMISSIONS (GSM1900).....		24
7.7.3 RADIATED SPURIOUS EMISSIONS (WCDMA850).....		25
7.7.4 RADIATED SPURIOUS EMISSIONS (WCDMA1900).....		26
7.7.5 RADIATED SPURIOUS EMISSIONS (WCDMA1700).....		27
7.8 FREQUENCY STABILITY / VARIATION OF AMBIENT TEMPERATURE		28
7.8.1 FREQUENCY STABILITY (GSM850)		28
7.8.2 FREQUENCY STABILITY (GSM1900)		29
7.8.3 FREQUENCY STABILITY (WCDMA850)		30
7.8.4 FREQUENCY STABILITY (WCDMA1900)		31
7.8.5 FREQUENCY STABILITY (WCDMA1700)		32
8. TEST PLOTS.....		33

FCC CERTIFICATION REPORT			www.hct.co.kr
Test Report No. HCTR1210FR05-3	Date of Issue: November 14, 2012	EUT Type: CDMA/GSM/WCDMA/LTE Telematics	FCC ID: BEJLTC10N



MEASUREMENT REPORT

1. GENERAL INFORMATION

Applicant Name: LG Electronics Inc.

Address: 19-1, Cheongho-ri, Jinwi-myeon, Pyeongtaek-si, Gyeonggi-do 451-713, Korea

FCC ID: BEJLTC10N

Application Type: Certification

FCC Classification: PCS Licensed Transmitter (PCB)

FCC Rule Part(s): §22, §24, §27, §2

EUT Type: CDMA/GSM/WCDMA/LTE Telematics

FCC Model(s): TC10AF3NU

Tx Frequency: 824.20 - 848.80 MHz (GSM850)
826.40 - 846.60 MHz (WCDMA850)
1 850.20 - 1 909.80 MHz (GSM1900)
1 852.4 - 1 907.6 MHz (WCDMA1900)
1 712.4 - 1 752.6 MHz (WCDMA1700)

Rx Frequency: 869.20 - 893.80 MHz (GSM850)
871.40 - 891.60 MHz (WCDMA850)
1 930.20 - 1 989.80 MHz (GSM1900)
1 932.4 - 1 987.6 MHz (WCDMA1900)
2 112.4 - 2 152.6 MHz (WCDMA1700)

Max. Conducted Power: 2.344 W GSM850 (33.70 dBm) / 1.062 W GSM1900 (30.26 dBm)
0.593 W EDGE850 (27.73 dBm) / 0.457 W EDGE1900 (26.60 dBm)
0.255 W WCDMA850 (24.06 dBm) / 0.243 W WCDMA1900 (23.86 dBm)
0.230 W WCDMA1700 (23.61 dBm)

Emission Designator(s): 245 KGXW (GSM850) 244 KGXW (GSM1900)
243 KG7W (GSM850 EDGE) 243 KG7W (GSM1900 EDGE)
4M17F9W (WCDMA850) 4M17F9W (WCDMA1900)
4M19F9W (WCDMA1700)

Date(s) of Tests: September 10, 2012 ~ November 07, 2012

Antenna Specification Manufacturer: Laird Technologies
Antenna type: MIMO capable vehicle dome antenna
Peak Gain: GSM850/WCDMA850 : 1.52 dBi
GSM1900/WCDMA1900 : 4.55 dBi
WCDMA1700 : 0.61 dBi

FCC CERTIFICATION REPORT			www.hct.co.kr
Test Report No. HCTR1210FR05-3	Date of Issue: November 14, 2012	EUT Type: CDMA/GSM/WCDMA/LTE Telematics	FCC ID: BEJLTC10N



2. INTRODUCTION

2.1. EUT DESCRIPTION

The LG Electronics Inc. TC10AF3NU CDMA/GSM/WCDMA/LTE Telematics consists of GSM850, GSM1900, WCDMA850, WCDMA1900, AWS WCDMA1700, GPRS Class12, EDGE Class12, HSDPA and HSUPA.

2.2. MEASURING INSTRUMENT CALIBRATION

The measuring equipment, which was utilized in performing the tests documented herein, has been calibrated in accordance with the manufacturer's recommendations for utilizing calibration equipment, which is traceable to recognized national standards.

2.3. TEST FACILITY

The Fully-anechoic chamber and conducted measurement facility used to collect the radiated data are located at the 105-1, Jangam-ri , Majang-Myeon, Icheon-si, 467-811, KOREA.

The site is constructed in conformance with the requirements of ANSI C63.4 and CISPR Publication 22. Detailed description of test facility was submitted to the Commission and accepted dated March 02, 2011 (Registration Number: 90661)

FCC CERTIFICATION REPORT			www.hct.co.kr
Test Report No. HCTR1210FR05-3	Date of Issue: November 14, 2012	EUT Type: CDMA/GSM/WCDMA/LTE Telematics	FCC ID: BEJLTTTC10N

3. DESCRIPTION OF TESTS

3.1 EFFECTIVE RADIATED POWER/EQUIVALENT ISOTROPIC RADIATED POWER

Test Set-up

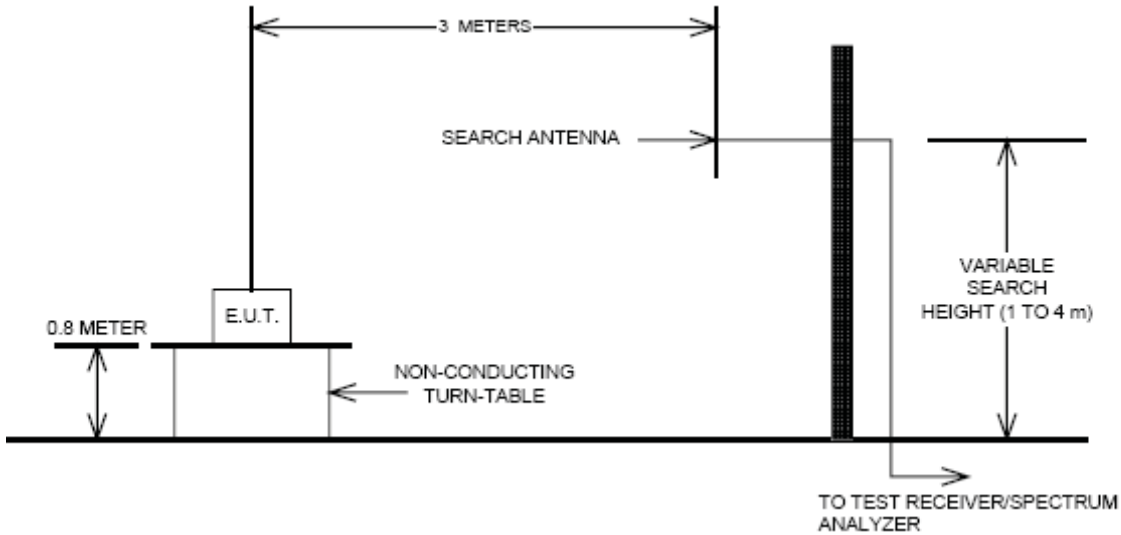

Radiated emission measurements were performed at an Fully-anechoic chamber.

The equipment under test is placed on a non-conductive table 3-meters from the receive antenna. A turntable was rotated 360° and the receiving antenna scanned from 1-4m in order to capture the maximum emission. A half wave dipole was substituted in place of the EUT. This dipole antenna was driven by a signal generator and the previously recorded signal was duplicated.

The maximum EIRP was calculated by adding the forward power to the calibrated source plus its appropriate gain value. These steps were carried out with the receiving antenna in both vertical and horizontal polarization. For readings above 1GHz, the above procedure is repeated using horn antennas and the difference between the gain of the horn and an isotropic antenna are taken into consideration



3.2 PEAK- TO- AVERAGE RATIO

A peak to average ratio measurement is performed at the conducted port of the EUT. For CDMA and WCDMA signals, the spectrum analyzers Complementary Cumulative Distribution Function (CCDF) measurement profile is used to determine the largest deviation between the average and the peak power of the EUT in a given bandwidth. The CCDF curve shows how much time the peak waveform spends at or above a given average power level. The percent of time the signal spends at or above the level defines the probability for that particular power level. For GSM signals, an average and a peak trace are used on a spectrum analyzer to determine the largest deviation between the average and the peak power of the EUT in a bandwidth greater than the emission bandwidth. Plots of the EUT's Peak- to- Average Ratio are shown herein.

FCC CERTIFICATION REPORT			www.hct.co.kr
Test Report No. HCTR1210FR05-3	Date of Issue: November 14, 2012	EUT Type: CDMA/GSM/WCDMA/LTE Telematics	FCC ID: BEJLTTTC10N

3.3 OCCUPIED BANDWIDTH.

Test set-up

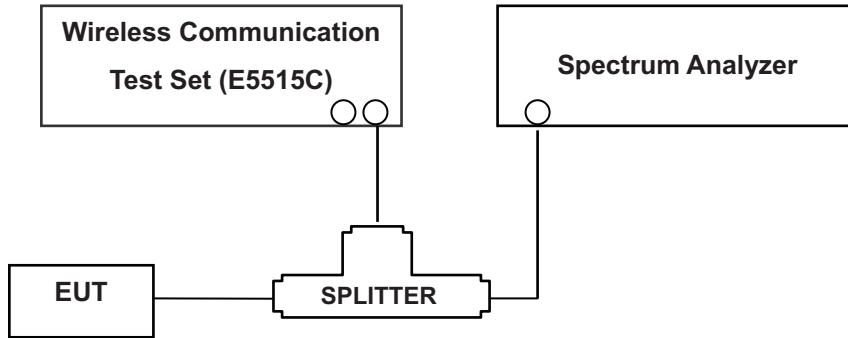

(Configuration of conducted Emission measurement)

The width of a frequency band such that, below the lower and above the upper frequency limits, the mean powers emitted are each equal to a specified percentage 0.5 % of the total mean power of a given emission.

Test Procedure

The EUT makes a call to the communication simulator. The power was measured with R&S Spectrum Analyzer. All measurements were done at 3 channels(low, middle and high operational range.)

The conducted occupied bandwidth used the power splitter via EUT RF power connector between simulation base station and spectrum analyzer.

The communication simulator station system controlled a EUT to export maximum output power under transmission mode and specific channel frequency. Use OBW measurement function of Spectrum analyzer to measure 99 % occupied bandwidth

3.4 SPURIOUS AND HARMONIC EMISSIONS AT ANTENNA TERMINAL.

Test Procedure

The level of the carrier and the various conducted spurious and harmonic frequencies is measured by means of a calibrated spectrum analyzer.

On any frequency outside a licensee's frequency block, the power of any emission shall be attenuated below the transmitter power (P) by at least $43 + 10 \log(P)$ dB. The RBW settings used in the testing are greater than 1 % of the occupied bw. The 1 MHz RBW was used to scan from 10 MHz to 10 GHz. (GSM1900 Mode: 10 MHz to 20 GHz). A display line was placed at - 13 dBm to show compliance. The high, lowest and a middle channel were tested for out of band measurements.

- Band Edge Requirement : According to FCC 22.917 , 24.238(a) specified that power of any emission outside of The authorized operating frequency ranges must be attenuated below the transmitting power (P) by a factor of at least $43 + 10 \log(P)$ dB. In the 1 MHz bands immediately outside and adjacent to the frequency block a resolution bandwidth of at least one percent of the emission bandwidth of the fundamental emission of the transmitter may be employed.

The EUT makes a call to the communication simulator. The power was measured with R&S Spectrum Analyzer. All measurements were done at 2 channels(low and high operational frequency range.)

The band edge measurement used the power splitter via EUT RF power connector between simulation base station and spectrum analyzer.

The center frequency of spectrum is the band edge frequency and span is 1MHz RB of the spectrum is 3KHz and VB of the spectrum is 3KHz (GSM)

The center frequency of spectrum is the band edge frequency and span is 5MHz RB of the spectrum is 100KHz and VB of the spectrum is 100KHz(WCDMA)

NOTES: The analyzer plot offsets were determined by below conditions.

- For GSM850, total offset 27.5 dBm = 20 dBm attenuator + 6 dBm Splitter + 1.5 dBm RF Cables.
- For GSM1900, total offset 28.3 dBm = 20 dBm attenuator + 6 dBm Splitter + 2.3 dBm RF Cables.
- For WCDMA850, total offset 27.6 dBm = 20 dBm attenuator + 6 dBm Splitter + 1.6 dBm RF Cables.
- For WCDMA1700, total offset 28.5 dBm = 20 dBm attenuator + 6 dBm Splitter + 2.5 dBm RF Cables.
- For WCDMA1900, total offset 28.6 dBm = 20 dBm attenuator + 6 dBm Splitter + 2.6 dBm RF Cables.

FCC CERTIFICATION REPORT			www.hct.co.kr
Test Report No. HCTR1210FR05-3	Date of Issue: November 14, 2012	EUT Type: CDMA/GSM/WCDMA/LTE Telematics	FCC ID: BEJLTTTC10N

3.5 RADIATED SPURIOUS AND HARMONIC EMISSIONS

Test Set-up

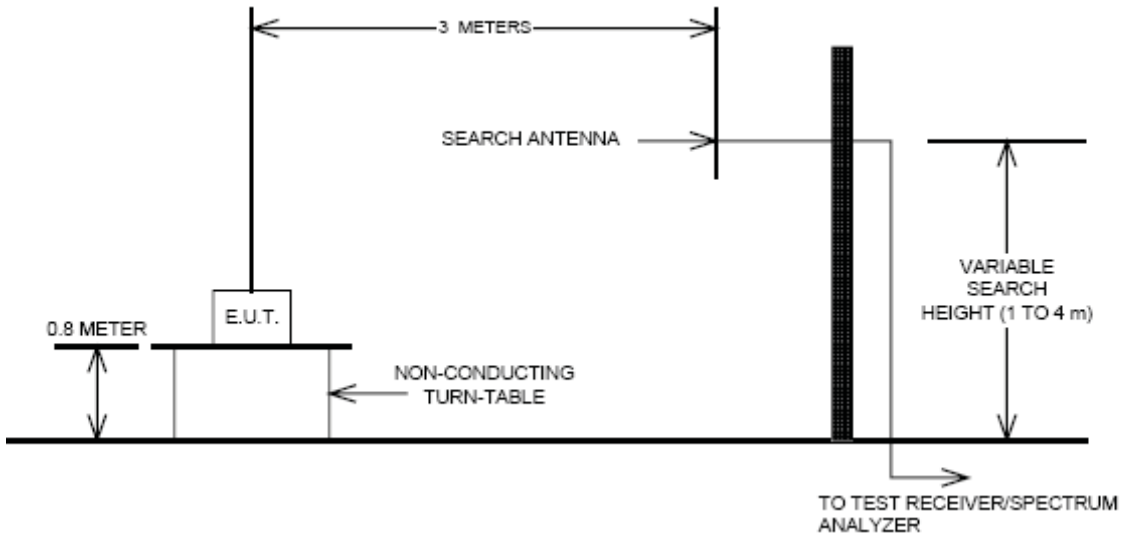

The measurement facilities used for this test have been documented in previous filings with the commission pursuant to section § 2.948. The Fully-anechoic chamber meets requirements in ANSI C63.4 –2003. A mast capable of lifting the receiving antenna from a height of one to four meters is used together with a rotatable platform mounted at three from the antenna mast.

- 1) The unit mounted on a turntable 1.5 m × 1.0 m × 0.80 m is 0.8 meter above test site ground level.
- 2) During the emission test, the turntable is rotated and the EUT is manipulated to find the configuration resulting in maximum emission under normal condition of installation and operation.
- 3) The antenna height and polarization are also varied from 1 to 4 meters until the maximum signal is found.
- 4) The spectrum shall be scanned up to the 10th harmonic of the fundamental frequency.

Test Procedure

The equipment under test is placed on a non-conductive table 3-meters from the receive antenna. A turntable was rotated 360° and the receiving antenna scanned from 1-4m in order to capture the maximum emission. A half wave dipole was substituted in place of the EUT. This dipole antenna was driven by a signal generator and the previously recorded signal was duplicated.

The maximum EIRP was calculated by adding the forward power to the calibrated source plus its appropriate gain value. These steps were carried out with the receiving antenna in both vertical and horizontal polarization. For readings above 1GHz, the above procedure is repeated using horn antennas and the difference between the gain of the horn and an isotropic antenna are taken into consideration.

FCC CERTIFICATION REPORT			www.hct.co.kr
Test Report No. HCTR1210FR05-3	Date of Issue: November 14, 2012	EUT Type: CDMA/GSM/WCDMA/LTE Telematics	FCC ID: BEJLTC10N

3.6 FREQUENCY STABILITY / VARIATION OF AMBIENT TEMPERATURE

Test Set-up

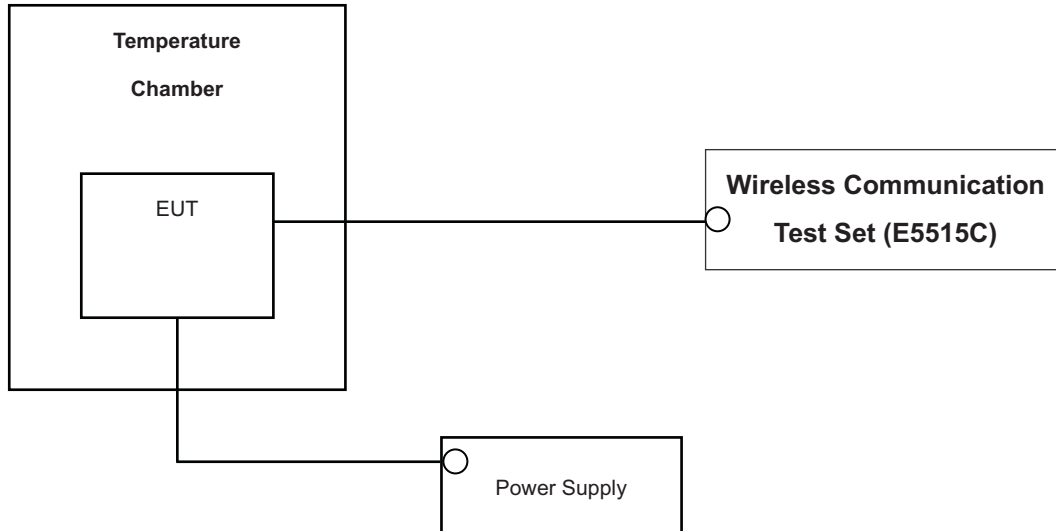

* Nominal Operating Voltage

Test Procedure

The frequency stability of the transmitter is measured by:

- a.) **Temperature:** The temperature is varied from - 30 °C to + 50 °C using an environmental chamber.
- b.) **Primary Supply Voltage:** The primary supply voltage is varied from battery end point to 115 % of the voltage normally at the input to the device or at the power supply terminals if cables are not normally supplied.

Specification — the frequency stability shall be sufficient to ensure that the fundamental emission stays within the authorized frequency block. The frequency stability of the transmitter shall be maintained within $\pm 0.00025\%$ (± 2.5 ppm) of the center frequency.

Time Period and Procedure:

The carrier frequency of the transmitter is measured at room temperature (20°C to provide a reference).

1. The equipment is turned on in a “standby” condition for one minute before applying power to the transmitter. Measurement of the carrier frequency of the transmitter is made within one minute after applying power to the transmitter.
2. Frequency measurements are made at 10°C intervals ranging from -30°C to +50°C. A period of at least one half-hour is provided to allow stabilization of the equipment at each temperature level.

FCC CERTIFICATION REPORT			www.hct.co.kr
Test Report No. HCTR1210FR05-3	Date of Issue: November 14, 2012	EUT Type: CDMA/GSM/WCDMA/LTE Telematics	FCC ID: BEJLTC10N

4. LIST OF TEST EQUIPMENT

Manufacture	Model/ Equipment	Serial Number	Calibration Interval	Calibration Due
Agilent	E9327A/ Power Sensor	MY4442009	Annual	05/02/2013
R&S	CMW500/ Base Station	1201.0002K50_116858	Annual	01/17/2013
MITEQ	AMF-6D-001180-35-20P/AMP	1081666	Annual	09/11/2013
Wainwright	WHK1.2/15G-10EF/H.P.F	2	Annual	05/02/2013
Wainwright	WHK3.3/18G-10EF/H.P.F	1	Annual	05/02/2013
Hewlett Packard	11667B / Power Splitter	10126	Annual	11/04/2012
Digital	EP-3010/ Power Supply	3110117	Annual	11/07/2012
Schwarzbeck	UHAP/ Dipole Antenna	557	Biennial	03/11/2013
Schwarzbeck	UHAP/ Dipole Antenna	558	Biennial	03/11/2013
Korea Engineering	KR-1005L / Chamber	KRAB05063-3CH	Annual	11/07/2012
Schwarzbeck	BBHA 9120D/ Horn Antenna	296	Biennial	02/20/2014
Agilent	E4440A/Spectrum Analyzer	US45303008	Annual	05/02/2013
WEINSCHTEL	ATTENUATOR	BR0592	Annual	11/07/2012
REOHDE&SCHWARZ	FSV40/Spectrum Analyzer	1307.9002K40-100931-NK	Annual	06/11/2013
Agilent	8960 (E5515C)/ Base Station	GB44400269	Annual	02/10/2013

5. SUMMARY OF TEST RESULTS

FCC Part Section(s)	Test Description	Test Limit	Test Condition	Test Result
2.1049, 22.917(a), 24.238(a), 27.53(h)	Occupied Bandwidth	N/A	CONDUCTED	PASS
2.1051, 22.917(a), 24.238(a), 27.53(h)	Band Edge / Spurious and Harmonic Emissions at Antenna Terminal.	< 43 + 10log10 (P[Watts]) at Band Edge and for all out-of-band emissions		PASS
2.1046	Conducted Output Power	-		PASS
24.232(d), 27.50(d)(5)	Peak- to- Average Ratio	< 13 dB		PASS
2.1055, 22.355, 24.235, 27.54	Frequency stability / variation of ambient temperature	< 2.5 ppm		PASS
22.913(a)(2) 24.232(c), 27.50(d)(4)	Effective Radiated Power	< 7 Watts max. ERP	RADIATED	PASS
	Equivalent Isotropic Radiated Power	< 2 Watts max. EIRP < 1 Watts max. EIRP(AWS)		PASS
2.1053, 22.917(a), 24.238(a), 27.53(h)	Radiated Spurious and Harmonic Emissions	< 43 + 10log10 (P[Watts]) for all out-of band emissions		PASS

6. SAMPLE CALCULATION

A. ERP Sample Calculation

Mode	Ch./ Freq.		Measured Level(dBm)	Substitute LEVEL(dBm)	Ant. Gain (dBd)	C.L	Pol.	ERP	
	channel	Freq.(MHz)						W	dBm
GSM850	128	824.20	-15.19	33.71	-10.54	1.61	V	0.143	21.56

ERP = SubstituteLEVEL(dBm) + Ant. Gain – CL(Cable Loss)

- 1) The EUT mounted on a non-conductive turntable is 0.8 meter above test site ground level.
- 2) During the test , the turn table is rotated and the antenna height is also varied from 1 to 4 meters until the maximum signal is found.
- 3) Record the field strength meter's level.
- 4) Replace the EUT with dipole/Horn antenna that is connected to a calibrated signal generator.
- 5) Increase the signal generator output till the field strength meter's level is equal to the item (3).
- 6) The signal generator output level with Ant. Gain and cable loss are the rating of effective radiated power (ERP).

B. Emission Designator

GSM Emission Designator

Emission Designator = 249KGXW

GSM BW = 249 kHz

G = Phase Modulation

X = Cases not otherwise covered

W = Combination (Audio/Data)

WCDMA Emission Designator

Emission Designator = 4M17F9W

WCDMA BW = 4.17 MHz

F = Frequency Modulation

9 = Composite Digital Info

W = Combination (Audio/Data)

FCC CERTIFICATION REPORT			www.hct.co.kr
Test Report No. HCTR1210FR05-3	Date of Issue: November 14, 2012	EUT Type: CDMA/GSM/WCDMA/LTE Telematics	FCC ID: BEJLTTTC10N

7. TEST DATA

7.1 CONDUCTED OUTPUT POWER

A base station simulator was used to establish communication with the EUT. The base station simulator parameters were set to produce the maximum power from the EUT. This device was tested under all configurations and the highest power is reported. Conducted Output Powers of EUT are reported below.

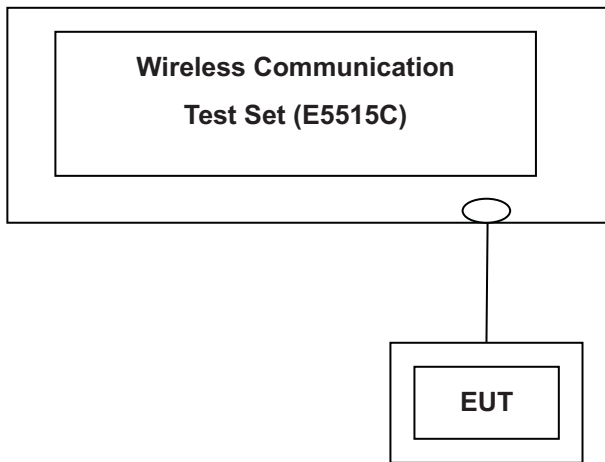

Test Result

Band	Channel	Voice	GPRS Data			
		GSM (dBm)	GPRS 1 TX Slot (dBm)	GPRS 2 TX Slot (dBm)	GPRS 3 TX Slot (dBm)	GPRS 4 TX Slot (dBm)
GSM 850	128	33.28	33.27	30.92	29.57	28.18
	190	33.48	33.46	31.12	29.78	28.56
	251	33.70	33.69	31.33	29.97	28.80
GSM 1900	512	30.26	30.24	27.85	26.34	25.47
	661	29.92	29.90	27.73	26.30	25.37
	810	30.20	30.19	27.92	26.48	25.43

(GSM Conducted Maximum Output Powers)

Band	Channel	EDGE Data			
		EDGE 1 TX Slot (dBm)	EDGE 2 TX Slot (dBm)	EDGE 3 TX Slot (dBm)	EDGE 4 TX Slot (dBm)
GSM 850	128	27.47	25.46	23.81	22.93
	190	27.59	25.59	24.02	23.03
	251	27.73	25.72	24.15	23.29
GSM 1900	512	26.43	24.48	23.07	21.52
	661	26.34	24.38	22.96	21.27
	810	26.60	24.64	23.18	21.52

(GSM EDGE Conducted Output Powers)

3GPP Release Version	Mode	3GPP 34.121	Cellular Band [dBm]			MPR
		Subtest	UL 4132 (826.4)	UL 4183 (836.6)	UL 4233 (846.6)	
			DL 4357	DL 4408	DL 4458	
99	WCDMA	12.2 kbps RMC	23.92	24.06	23.82	-
99	WCDMA	12.2 kbps AMR	23.90	23.99	23.82	-
5	HSDPA	Subtest 1	23.92	24.06	23.95	0
5		Subtest 2	23.94	24.05	23.96	0
5		Subtest 3	23.54	23.45	23.46	-0.5
5		Subtest 4	23.54	23.49	23.47	-0.5
6	HSUPA	Subtest 1	23.57	23.52	23.54	0
6		Subtest 2	22.13	22.13	21.75	-2
6		Subtest 3	22.73	22.63	22.47	-1
6		Subtest 4	22.40	22.40	22.54	-2
6		Subtest 5	23.01	23.12	23.35	0

3GPP Release Version	Mode	3GPP 34.121	PCS Band [dBm]			MPR
		Subtest	UL 9262 (1852.4)	UL 9400 (1880.0)	UL 9538 (1907.6)	
			DL 9662	DL 9800	DL 9938	
99	WCDMA	12.2 kbps RMC	23.33	23.36	23.80	-
99	WCDMA	12.2 kbps AMR	23.32	23.36	23.85	-
5	HSDPA	Subtest 1	23.25	23.29	23.85	0
5		Subtest 2	23.23	23.31	23.86	0
5		Subtest 3	22.78	22.76	23.38	-0.5
5		Subtest 4	22.77	22.76	23.38	-0.5
6	HSUPA	Subtest 1	23.10	23.09	23.22	0
6		Subtest 2	21.35	21.72	22.22	-2
6		Subtest 3	21.85	22.15	22.74	-1
6		Subtest 4	22.08	21.79	22.19	-2
6		Subtest 5	22.75	23.09	22.99	0

3GPP Release Version	Mode	3GPP 34.121	AWS Band [dBm]			MPR
		Subtest	UL 1312 (1712.4)	UL 1412 (1732.4)	UL 1513 (1752.6)	
			DL 1537	DL 1637	DL 1738	
99	WCDMA	12.2 kbps RMC	23.61	23.53	23.58	-
99	WCDMA	12.2 kbps AMR	23.61	23.55	23.57	-
5	HSDPA	Subtest 1	22.56	22.53	22.53	0
5		Subtest 2	22.60	22.54	22.52	0
5		Subtest 3	22.04	22.05	22.01	-0.5
5		Subtest 4	22.00	22.04	22.00	-0.5
6	HSUPA	Subtest 1	21.86	21.78	21.81	0
6		Subtest 2	18.87	18.87	18.92	-2
6		Subtest 3	20.50	20.85	20.88	-1
6		Subtest 4	18.91	18.87	18.94	-2
6		Subtest 5	21.44	21.48	21.52	0

(WCDMA Conducted Output Powers)

Note : Detecting mode is average.

7.2 PEAK-TO-AVERAGE RATIO

- Plots of the EUT's Peak- to- Average Ratio are shown Page 38, 43, 44.

7.3 OCCUPIED BANDWIDTH

Band	Channel	Frequency(MHz)	Data (GSM: kHz / WCDMA : MHz)
GSM850	128	824.20	242.1348
	190	836.60	242.6127
	251	848.80	244.7839
GSM850 EDGE	251	848.80	243.0986
GSM1900	512	1850.20	244.3512
	661	1880.00	242.0049
	810	1909.80	239.9686
GSM1900 EDGE	512	1850.20	242.6979
WCDMA850	4132	826.40	4.1722
	4183	836.60	4.1677
	4233	846.60	4.1747
WCDMA1900	9262	1852.40	4.1684
	9400	1880.00	4.1510
	9538	1907.60	4.1612
WCDMA1700	1312	1712.40	4.1712
	1412	1732.40	4.1846
	1513	1752.60	4.1437

- Plots of the EUT's Occupied Bandwidth are shown Page 34 ~ 37, 39 ~ 43.

7.4 CONDUCTED SPURIOUS EMISSIONS

Band	Channel	Frequency of Maximum Harmonic (GHz)	Maximum Data (dBm)
GSM850	128	7.0125	-29.19
	190	2.5125	-28.90
	251	6.9750	-30.25
GSM1900	512	13.3070	-26.45
	661	14.4800	-27.12
	810	13.3600	-26.29
WCDMA850	4132	7.0625	-37.50
	4183	1.6730	-34.54
	4233	1.6930	-35.40
WCDMA1900	9262	3.7020	-25.77
	9400	3.7550	-23.84
	9538	3.8150	-26.40
WCDMA1700	1312	3.4250	-34.24
	1412	3.4625	-35.81
	1513	3.5125	-35.76

- Plots of the EUT's Conducted Spurious Emissions are shown Page 58 ~ 73.

7.4.1 BAND EDGE

- Plots of the EUT's Band Edge are shown Page 44 ~ 58.

7.5 EFFECTIVE RADIATED POWER OUTPUT (GSM / WCDMA)

(GSM850 Mode)

Ch./ Freq.		Measured Level(dBm)	Substitute LEVEL (dBm)	Ant. Gain (dBd)	C.L	Pol.	ERP	
channel	Freq.(MHz)						W	dBm
128	824.20	-6.30	42.63	-10.54	1.61	V	1.117	30.48
190	836.60	-6.42	42.50	-10.50	1.67	V	1.079	30.33
251	848.80	-6.27	42.79	-10.47	1.64	V	1.169	30.68
EDGE 251	848.80	-9.38	39.68	-10.47	1.64	V	0.571	27.57

(WCDMA850 Mode)

Ch./ Freq.		Measured Level(dBm)	Substitute LEVEL (dBm)	Ant. Gain (dBd)	C.L	Pol.	ERP	
channel	Freq.(MHz)						W	dBm
4132	826.40	-12.51	36.42	-10.54	1.61	V	0.267	24.27
4183	836.60	-12.89	36.03	-10.50	1.67	V	0.243	23.86
4233	846.60	-13.22	35.66	-10.47	1.65	V	0.226	23.54

Note: Standard batteries are the only options for this phone. And a peak detector is used.

NOTES:

Effective Radiated Power Output Measurements by Substitution Method

according to ANSI/TIA/EIA-603-C-2004, Aug. 17, 2004:

The EUT was placed on a non-conductive styrofoam resin table table 3-meters from the receive antenna. The receive antenna height and turntable rotation was adjusted for the highest reading on the receive spectrum analyzer. For CDMA signals, a peak detector is used, with RBW = VBW = 3 MHz. For WCDMA signals, a peak detector is used, with RBW = VBW = 5MHz. For AMPS, GSM, and NADC TDMA signals, a peak detector is used, with RBW = VBW = 1 MHz. A half-wave dipole was substituted in place of the EUT. This dipole antenna was driven by a signal generator and the level of the signal generator was adjusted to obtain the same receive spectrum analyzer reading. The conducted power at the terminals of the dipole is measured. The ERP is recorded.

This device was tested under all configurations and the highest power is reported in WCDMA mode with HSDPA Inactive at 12.2 kbps RMC and TPC bits all set to "1" and in GSM mode and using a Power Control Level of "0" in the PCS Band and "5" in the Cellular Band. This unit was tested with its standard battery. Also, we have done x, y, z planes in EUT and horizontal and vertical polarization in detecting antenna. The worst case of the EUT is y plane in GSM850 and WCDMA850 mode. Also worst case of detecting Antenna is vertical polarization in GSM850 and WCDMA850 mode.

The EDGE mode testing were performed using 1Tx because 1Tx is highest power in EDGE mode.

FCC CERTIFICATION REPORT			www.hct.co.kr
Test Report No. HCTR1210FR05-3	Date of Issue: November 14, 2012	EUT Type: CDMA/GSM/WCDMA/LTE Telematics	FCC ID: BEJLTC10N

7.6 EQUIVALENT ISOTROPIC RADIATED POWER (GSM / WCDMA)

(GSM1900 Mode)

Ch./ Freq.		Measured Level(dBm)	Substitute LEVEL (dBm)	Ant. Gain (dBi)	C.L	Pol.	EIRP	
channel	Freq.(MHz)						W	dBm
512	1,850.20	-10.77	21.17	10.23	1.78	H	0.916	29.62
661	1,880.00	-11.53	20.60	10.25	1.77	H	0.809	29.08
810	1,909.80	-10.34	21.86	10.29	1.75	H	1.096	30.40
EDGE 810	1,909.80	-11.06	21.14	10.29	1.75	H	0.929	29.68

(WCDMA1900 Mode)

Ch./ Freq.		Measured Level(dBm)	Substitute LEVEL (dBm)	Ant. Gain (dBi)	C.L	Pol.	EIRP	
channel	Freq.(MHz)						W	dBm
9262	1,852.40	-14.56	17.38	10.23	1.78	H	0.383	25.83
9400	1,880.00	-16.27	15.86	10.25	1.77	H	0.272	24.34
9538	1,907.60	-15.12	17.08	10.29	1.75	H	0.365	25.62

(WCDMA1700 Mode)

Ch./ Freq.		Measured Level(dBm)	Substitute LEVEL (dBm)	Ant. Gain (dBi)	C.L	Pol.	EIRP	
channel	Freq.(MHz)						W	dBm
1312	1712.40	-14.51	17.09	10.03	1.71	H	0.348	25.41
1412	1732.40	-14.47	17.34	10.06	1.73	H	0.369	25.67
1513	1752.60	-14.32	17.59	10.10	1.73	H	0.394	25.96

Note: Standard batteries are the only options for this phone. And a peak detector is used.

NOTES:

Equivalent Isotropic Radiated Power Measurements by Substitution Method according to ANSI/TIA/EIA-603-C-2004, Aug. 17, 2004:

The EUT was placed on a non-conductive styrofoam resin table 3-meters from the receive antenna. The receive antenna height and turntable rotation was adjusted for the highest reading on the receive spectrum analyzer. For CDMA signals, a peak detector is used, with RBW = VBW = 3 MHz. For WCDMA signals, a peak detector is used, with RBW = VBW = 5MHz. For AMPS, GSM, and NADC TDMA signals, a peak detector is used, with RBW = VBW = 1 MHz. A Horn antenna was substituted in place of the EUT. This Horn antenna was driven by a signal generator and the level of the signal generator was adjusted to obtain the same receive spectrum analyzer reading. The conducted power at the terminals of the Horn antenna is measured. The

FCC CERTIFICATION REPORT			www.hct.co.kr
Test Report No. HCTR1210FR05-3	Date of Issue: November 14, 2012	EUT Type: CDMA/GSM/WCDMA/LTE Telematics	FCC ID: BEJLTTTC10N



difference between the gain of the horn and an isotropic antenna is taken into consideration and the EIRP is recorded.

This device was tested under all configurations and the highest power is reported in WCDMA mode with HSDPA Inactive at 12.2 kbps RMC and TPC bits all set to "1" and in GSM mode and using a Power Control Level of "0" in the PCS Band and "5" in the Cellular Band. This unit was tested with its standard battery. Also, we have done x, y, z planes in EUT and horizontal and vertical polarization in detecting antenna. The worst case of the EUT is z plane in GSM1900, WCDMA1900 and WCDMA1700 mode. Also worst case of detecting Antenna is in horizontal polarization in GSM1900, WCDMA1900 and WCDMA1700 mode.

The EDGE mode testing were performed using 1Tx because 1Tx is highest power in EDGE mode.

FCC CERTIFICATION REPORT			www.hct.co.kr
Test Report No. HCTR1210FR05-3	Date of Issue: November 14, 2012	EUT Type: CDMA/GSM/WCDMA/LTE Telematics	FCC ID: BEJLTC10N

7.7 RADIATED SPURIOUS EMISSIONS

7.7.1 RADIATED SPURIOUS EMISSIONS (GSM850)

- MEASURED OUTPUT POWER: 30.68 dBm = 1.169 W
- MODULATION SIGNAL: GSM850
- DISTANCE: 3 meters
- LIMIT: $-(43 + 10 \log_{10}(W)) =$ - 43.68 dBc

Ch.	Freq.(MHz)	Measured Level [dBm]	Ant. Gain (dBd)	Substitute Level [dBm]	C.L	Pol.	ERP (dBm)	dBc
128 (824.2)	1,648.40	-35.23	7.54	-44.52	1.71	H	-38.69	-69.37
	2,472.60	-34.45	8.41	-40.29	2.08	H	-33.96	-64.64
	3,296.80	-44.92	9.69	-51.06	2.45	V	-43.82	-74.50
190 (836.6)	1,673.20	-34.21	7.67	-43.82	1.74	H	-37.89	-68.57
	2,509.80	-37.89	8.42	-43.86	2.11	V	-37.55	-68.23
	3,346.40	-48.67	9.81	-55.33	2.48	V	-48.00	-78.68
251 (848.8)	1,697.60	-34.19	7.86	-43.61	1.70	H	-37.45	-68.13
	2,546.40	-39.00	8.45	-44.78	2.13	V	-38.46	-69.14
	3,395.20	-48.47	9.94	-55.09	2.53	V	-47.68	-78.36

NOTES: 1. Radiated Spurious Emission Measurements at 3 meters by Substitution Method

according to ANSI/TIA/EIA-603-C-2004, Aug. 17, 2004:

2. The magnitude of spurious emissions attenuated more than 20dB below the limit above 5th Harmonic for all channel.

3. we have done x, y, z planes in EUT and horizontal and vertical polarization in detecting antenna.

7.7.2 RADIATED SPURIOUS EMISSIONS (GSM1900)

- MEASURED OUTPUT POWER: 30.40 dBm = 1.096 W
- MODULATION SIGNAL: GSM1900
- DISTANCE: 3 meters
- LIMIT: - (43 + 10 log₁₀ (W)) = - 43.40 dBc

Ch.	Freq.(MHz)	Measured Level [dBm]	Ant. Gain (dBi)	Substitute Level [dBm]	C.L	Pol.	EIRP (dBm)	dBc
512 (1850.2)	3,700.40	-24.93	12.50	-29.90	2.55	H	-19.95	-50.35
	5,550.60	-35.29	13.04	-34.36	3.17	H	-24.49	-54.89
	7,400.80	-44.86	11.10	-33.76	3.54	V	-26.20	-56.60
661 (1880.0)	3,760.00	-25.48	12.54	-30.16	2.60	V	-20.22	-50.62
	5,640.00	-45.97	13.05	-44.43	3.21	V	-34.59	-64.99
	7,520.00	-49.03	10.99	-38.52	3.72	H	-31.25	-61.65
810 (1909.8)	3,819.60	-22.90	12.59	-27.34	2.59	H	-17.34	-47.74
	5,729.40	-41.57	13.07	-39.54	3.35	V	-29.82	-60.22
	7,639.20	-47.32	11.06	-37.34	3.23	H	-29.51	-59.91

- NOTES:**
1. Radiated Spurious Emission Measurements at 3 meters by Substitution Method according to ANSI/TIA/EIA-603-C-2004, Aug. 17, 2004:
 2. The magnitude of spurious emissions attenuated more than 20dB below the limit above 5th Harmonic for all channel.
 3. we have done x, y, z planes in EUT and horizontal and vertical polarization in detecting antenna.

7.7.3 RADIATED SPURIOUS EMISSIONS (WCDMA850)

- MEASURED OUTPUT POWER: 24.27 dBm = 0.267 W
- MODULATION SIGNAL: WCDMA850
- DISTANCE: 3 meters
- LIMIT: - (43 + 10 log₁₀ (W)) = - 37.27 dBc

Ch.	Freq.(MHz)	Measured Level [dBm]	Ant. Gain (dBd)	Substitute Level [dBm]	C.L	Pol.	ERP (dBm)	dBc
4,132 (826.4)	1,652.80	-35.31	7.54	-44.60	1.71	V	-38.77	-63.04
	2,479.20							
	3,305.60	-55.96	9.69	-62.10	2.45	V	-54.86	-79.13
4,183 (836.6)	1,673.20	-35.04	7.67	-44.65	1.74	H	-38.72	-62.99
	2,509.80							
	3,346.40	-56.69	9.81	-63.35	2.48	V	-56.02	-80.29
4,233 (846.6)	1,693.20	-31.60	7.86	-41.02	1.70	H	-34.86	-59.13
	2,539.80							
	3,386.40	-55.11	9.94	-61.73	2.53	V	-54.32	-78.59

- NOTES:**
1. Radiated Spurious Emission Measurements at 3 meters by Substitution Method according to ANSI/TIA/EIA-603-C-2004, Aug. 17, 2004:
 2. The magnitude of spurious emissions attenuated more than 20dB below the limit above 5th Harmonic for all channel.
 3. we have done x, y, z planes in EUT and horizontal and vertical polarization in detecting antenna.

7.7.4 RADIATED SPURIOUS EMISSIONS (WCDMA1900)

- MEASURED OUTPUT POWER: 25.83 dBm = 0.383 W
- MODULATION SIGNAL: WCDMA1900
- DISTANCE: 3 meters
- LIMIT: - (43 + 10 log₁₀(W)) = - 38.83 dBc

Ch.	Freq.(MHz)	Measured Level [dBm]	Ant. Gain (dBi)	Substitute Level [dBm]	C.L	Pol.	EIRP (dBm)	dBc
9262	3,704.80	-38.46	12.50	-43.43	2.55	V	-33.48	-59.31
	5,557.20	-54.36	13.00	-53.41	3.19	V	-43.60	-69.43
	7,409.60	-	-	-	-	-	-	-
9400	3,760.00	-31.93	12.54	-36.61	2.60	V	-26.67	-52.50
	5,640.00	-	-	-	-	-	-	-
	7,520.00	-	-	-	-	-	-	-
9538	3,815.20	-32.80	12.59	-37.24	2.59	V	-27.24	-53.07
	5,722.80	-56.18	13.07	-53.96	3.35	H	-44.24	-70.07
	7,630.40	-	-	-	-	-	-	-

- NOTES:**
1. Radiated Spurious Emission Measurements at 3 meters by Substitution Method according to ANSI/TIA/EIA-603-C-2004, Aug. 17, 2004:
 2. The magnitude of spurious emissions attenuated more than 20dB below the limit above 5th Harmonic for all channel.
 3. we have done x, y, z planes in EUT and horizontal and vertical polarization in detecting antenna.

7.7.5 RADIATED SPURIOUS EMISSIONS (WCDMA1700)

- MEASURED OUTPUT POWER: 25.96 dBm = 0.394 W
- MODULATION SIGNAL: WCDMA1700
- DISTANCE: 3 meters
- LIMIT: - (43 + 10 log₁₀ (W)) = - 38.96 dBc

Ch.	Freq.(MHz)	Measured Level [dBm]	Ant. Gain (dBi)	Substitute Level [dBm]	C.L	Pol.	EIRP (dBm)	dBc
1312 (1712.4)	3,424.80	-21.21	12.05	-27.90	2.53	H	-18.38	-44.34
	5,137.20	-32.62	12.61	-31.59	3.07	H	-22.05	-48.01
	6,849.60	-57.04	11.62	-46.44	3.61	H	-38.43	-64.39
1412 (1732.4)	3,464.80	-33.94	12.24	-40.41	2.49	H	-30.66	-56.62
	5,197.20	-42.17	12.68	-41.28	3.16	H	-31.76	-57.72
	6,929.60	-53.77	11.52	-42.77	3.68	H	-34.93	-60.89
1513 (1752.6)	3,505.20	-40.92	12.35	-46.94	2.57	V	-37.16	-63.12
	5,257.80	-44.57	12.75	-44.24	3.17	V	-34.66	-60.62
	7,010.40	-	-	-	-	-	-	-

- NOTES:**
1. Radiated Spurious Emission Measurements at 3 meters by Substitution Method according to ANSI/TIA/EIA-603-C-2004, Aug. 17, 2004:
 2. The magnitude of spurious emissions attenuated more than 20dB below the limit above 5th Harmonic for all channel.
 3. we have done x, y, z planes in EUT and horizontal and vertical polarization in detecting antenna.

7.8 FREQUENCY STABILITY / VARIATION OF AMBIENT TEMPERATURE

7.8.1 FREQUENCY STABILITY (GSM850)

- ▣ OPERATING FREQUENCY: 836,600,000 Hz
- ▣ CHANNEL: 190
- ▣ REFERENCE VOLTAGE: 12.0 VDC
- ▣ DEVIATION LIMIT: ± 0.000 25 % or 2.5 ppm

Voltage (%)	Power (VDC)	Temp. (°C)	Frequency (Hz)	Frequency Error (Hz)	Deviation (%)	ppm
100%	12.0	+20(Ref)	836 599 991	0	0.000 000	0.000
100%		-30	836 600 002	10.76	0.000 001	0.013
100%		-20	836 600 002	10.32	0.000 001	0.012
100%		-10	836 600 004	12.82	0.000 002	0.015
100%		0	836 600 004	12.66	0.000 002	0.015
100%		+10	836 600 003	11.36	0.000 001	0.014
100%		+30	836 600 004	13.07	0.000 002	0.016
100%		+40	836 600 003	11.53	0.000 001	0.014
100%		+50	836 600 002	10.67	0.000 001	0.013
115%		13.8	+20	836 600 000	8.94	0.000 001
85%	10.2	+20	836 599 999	7.73	0.000 001	0.009

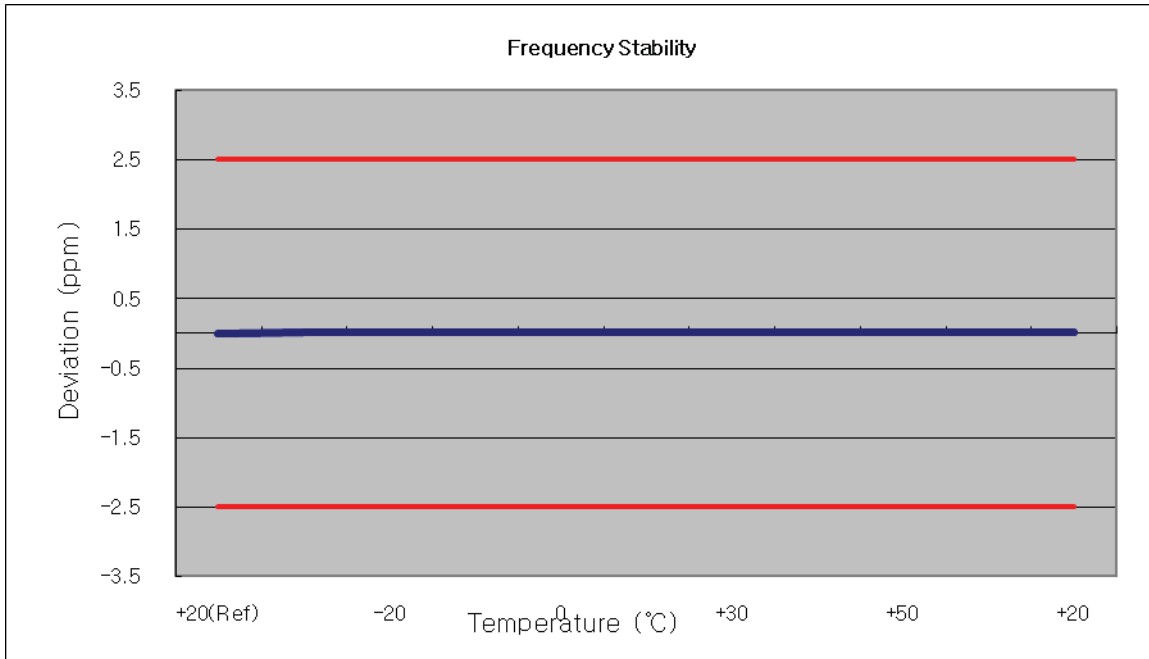

7.8.2 FREQUENCY STABILITY (GSM1900)

- ▣ OPERATING FREQUENCY: 1880,000,000 Hz
- ▣ CHANNEL: 661
- ▣ REFERENCE VOLTAGE: 12.0 VDC
- ▣ DEVIATION LIMIT: ± 0.000 25 % or 2.5 ppm

Voltage (%)	Power (VDC)	Temp. (°C)	Frequency (Hz)	Frequency Error (Hz)	Deviation (%)	ppm
100%	12.0	+20(Ref)	1879 999 977	0	0.000 000	0.000
100%		-30	1880 000 003	26.01	0.000 001	0.014
100%		-20	1879 999 992	15.37	0.000 001	0.008
100%		-10	1879 999 997	20.48	0.000 001	0.011
100%		0	1879 999 999	21.90	0.000 001	0.012
100%		+10	1879 999 999	22.12	0.000 001	0.012
100%		+30	1879 999 994	17.72	0.000 001	0.009
100%		+40	1879 999 999	22.13	0.000 001	0.012
100%		+50	1879 999 993	16.79	0.000 001	0.009
115%	13.8	+20	1879 999 999	22.68	0.000 001	0.012
85%	10.2	+20	1879 999 997	19.92	0.000 001	0.011

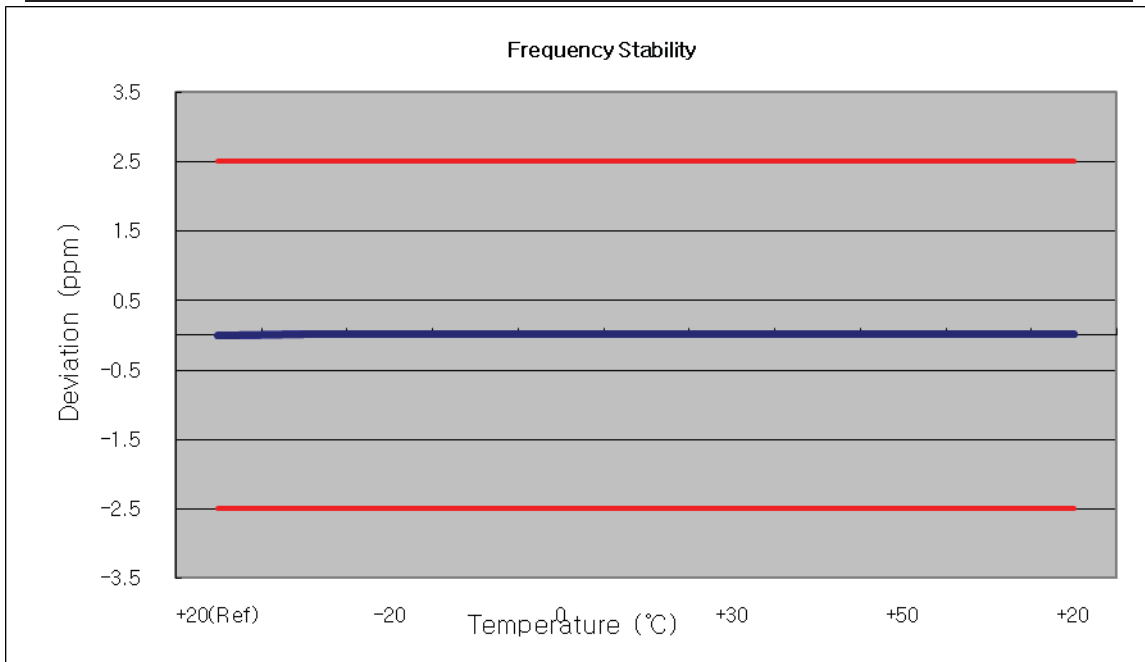

7.8.3 FREQUENCY STABILITY (WCDMA850)

- OPERATING FREQUENCY: 836,600,000 Hz
- CHANNEL: 4183
- REFERENCE VOLTAGE: 12.0 VDC
- DEVIATION LIMIT: ± 0.000 25 % or 2.5 ppm

Voltage (%)	Power (VDC)	Temp. (°C)	Frequency (Hz)	Frequency Error (Hz)	Deviation (%)	ppm
100%	12.0	+20(Ref)	836 599 998	0	0.000 000	0.000
100%		-30	836 599 999	-1.13	0.000 000	-0.001
100%		-20	836 599 998	-1.76	0.000 000	-0.002
100%		-10	836 600 002	2.01	0.000 000	0.002
100%		0	836 600 003	2.80	0.000 000	0.003
100%		+10	836 599 998	-1.93	0.000 000	-0.002
100%		+30	836 599 998	-1.71	0.000 000	-0.002
100%		+40	836 600 002	1.92	0.000 000	0.002
100%		+50	836 599 999	-1.49	0.000 000	-0.002
115%	13.8	+20	836 599 998	-2.41	0.000 000	-0.003
85%	10.2	+20	836 600 001	1.02	0.000 000	0.001

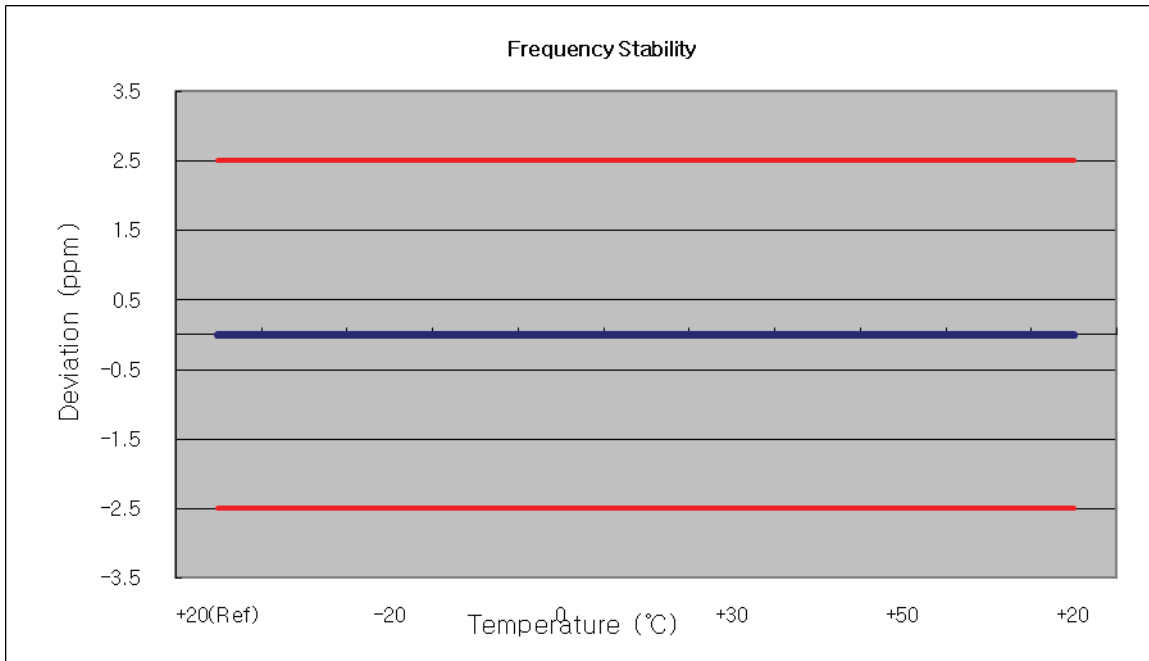

7.8.4 FREQUENCY STABILITY (WCDMA1900)

- OPERATING FREQUENCY: 1,880,000,000 Hz
- CHANNEL: 9400
- REFERENCE VOLTAGE: 12.0 VDC
- DEVIATION LIMIT: ± 0.000 25 % or 2.5 ppm

Voltage (%)	Power (VDC)	Temp. (°C)	Frequency (Hz)	Frequency Error (Hz)	Deviation (%)	ppm
100%	12.0	+20(Ref)	1880 000 009	0	0.000 000	0.000
100%		-30	1879 999 992	-8.17	0.000 000	-0.004
100%		-20	1879 999 993	-7.35	0.000 000	-0.004
100%		-10	1879 999 992	-8.42	0.000 000	-0.004
100%		0	1879 999 993	-7.05	0.000 000	-0.004
100%		+10	1879 999 992	-7.59	0.000 000	-0.004
100%		+30	1879 999 992	-8.39	0.000 000	-0.004
100%		+40	1879 999 991	-8.67	0.000 000	-0.005
100%		+50	1879 999 991	-9.10	0.000 000	-0.005
115%	13.8	+20	1879 999 992	-8.23	0.000 000	-0.004
85%	10.2	+20	1879 999 992	-8.49	0.000 000	-0.005

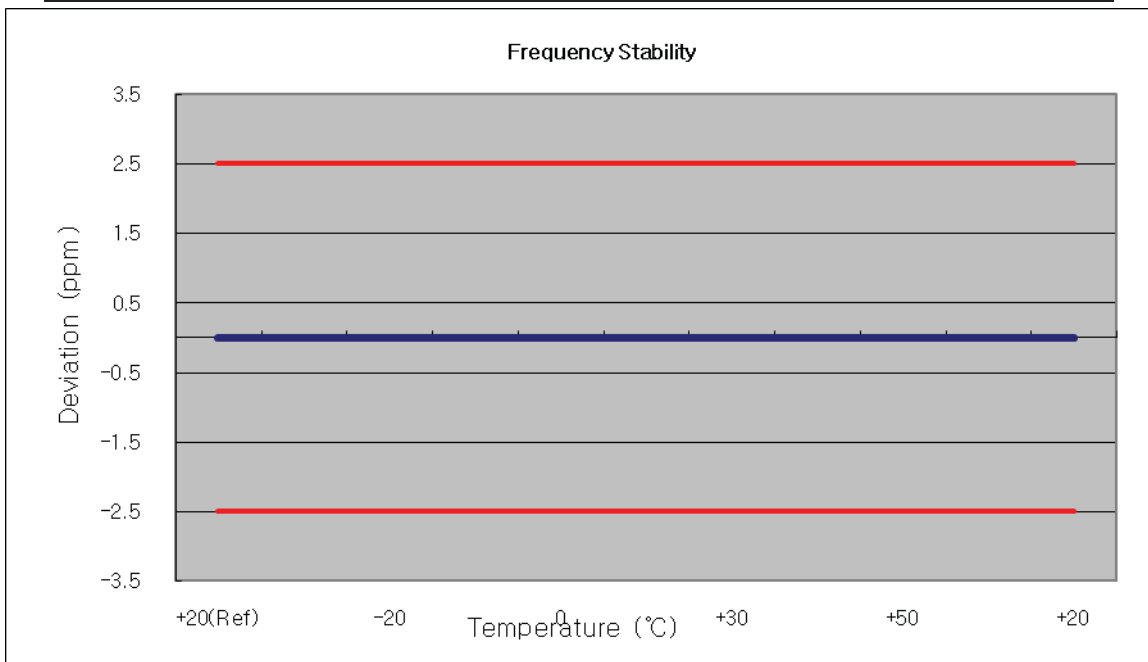

7.8.5 FREQUENCY STABILITY (WCDMA1700)

OPERATING FREQUENCY: 1,732.400,000 Hz
 CHANNEL: 1412
 REFERENCE VOLTAGE: 12.0 VDC
 DEVIATION LIMIT: ± 0.000 25 % or 2.5 ppm

Voltage (%)	Power (VDC)	Temp. (°C)	Frequency (Hz)	Frequency Error (Hz)	Deviation (%)	ppm
100%	12.0	+20(Ref)	1732 399 997	0	0.000 000	0.000
100%		-30	1732 400 005	4.54	0.000 000	0.003
100%		-20	1732 399 997	-3.24	0.000 000	-0.002
100%		-10	1732 399 996	-3.71	0.000 000	-0.002
100%		0	1732 400 004	3.93	0.000 000	0.002
100%		+10	1732 400 004	4.44	0.000 000	0.003
100%		+30	1732 400 003	2.96	0.000 000	0.002
100%		+40	1732 400 004	3.56	0.000 000	0.002
100%		+50	1732 399 995	-4.60	0.000 000	-0.003
115%	13.8	+20	1732 400 002	2.40	0.000 000	0.001
85%	10.2	+20	1732 400 004	4.07	0.000 000	0.002

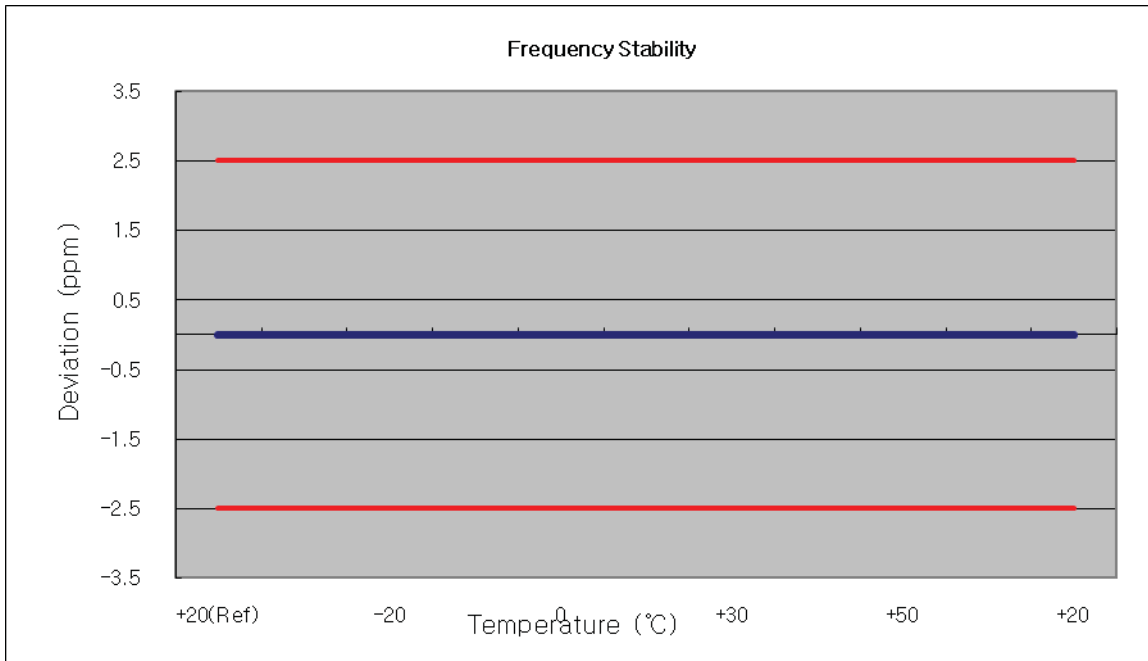



8. TEST PLOTS

FCC CERTIFICATION REPORT			www.hct.co.kr
Test Report No. HCTR1210FR05-3	Date of Issue: November 14, 2012	EUT Type: CDMA/GSM/WCDMA/LTE Telematics	FCC ID: BEJLTC10N

■ GSM850 MODE (128 CH.) Occupied Bandwidth

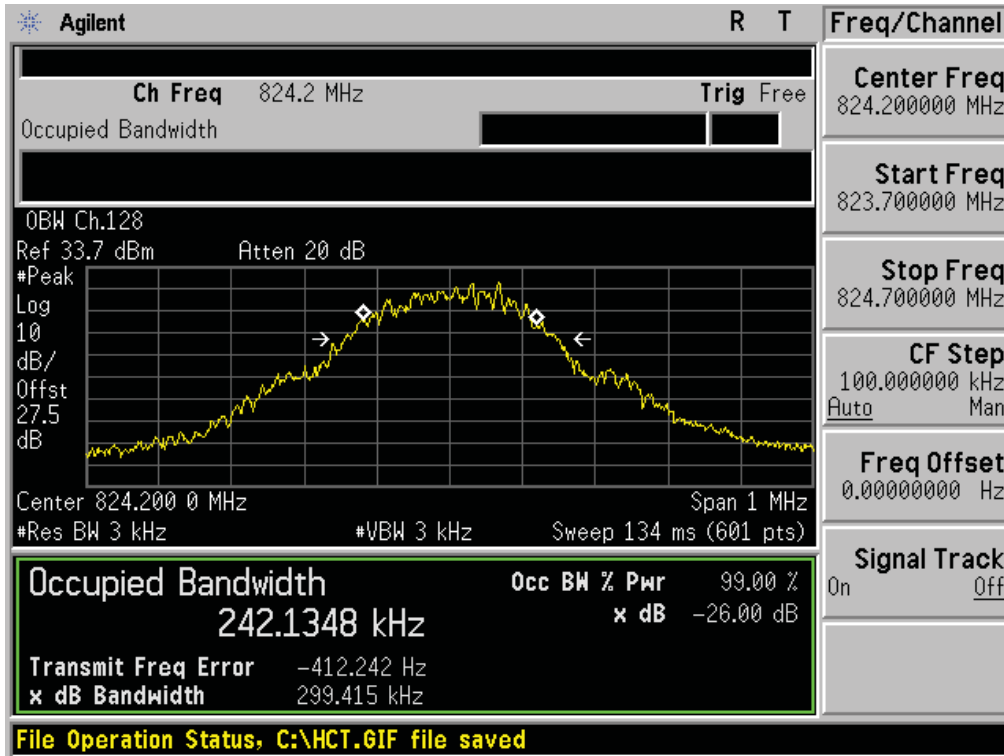

■ GSM850 MODE (190 CH.) Occupied Bandwidth

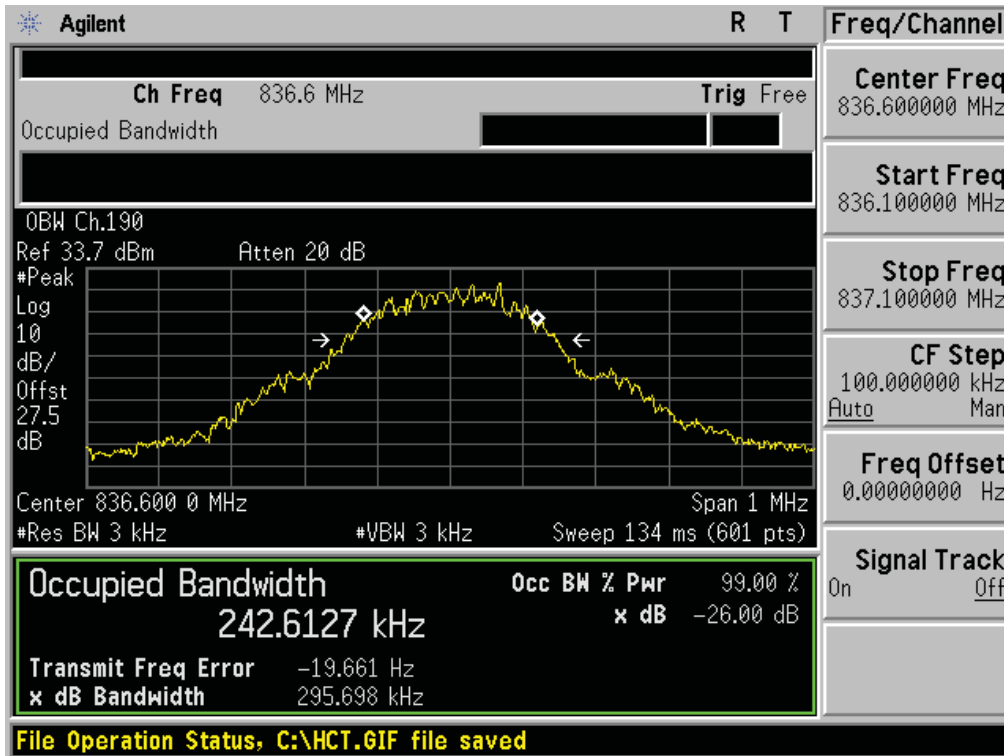

■ GSM850 MODE (251 CH.) Occupied Bandwidth

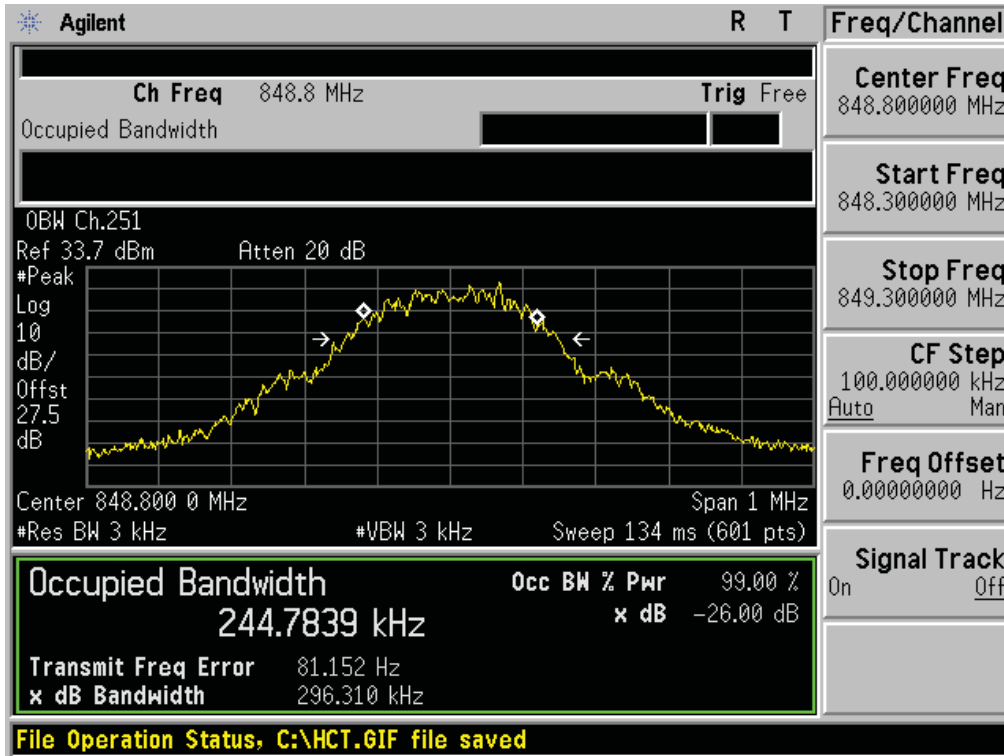

■ GSM850 EDGE (251 CH.) Occupied Bandwidth

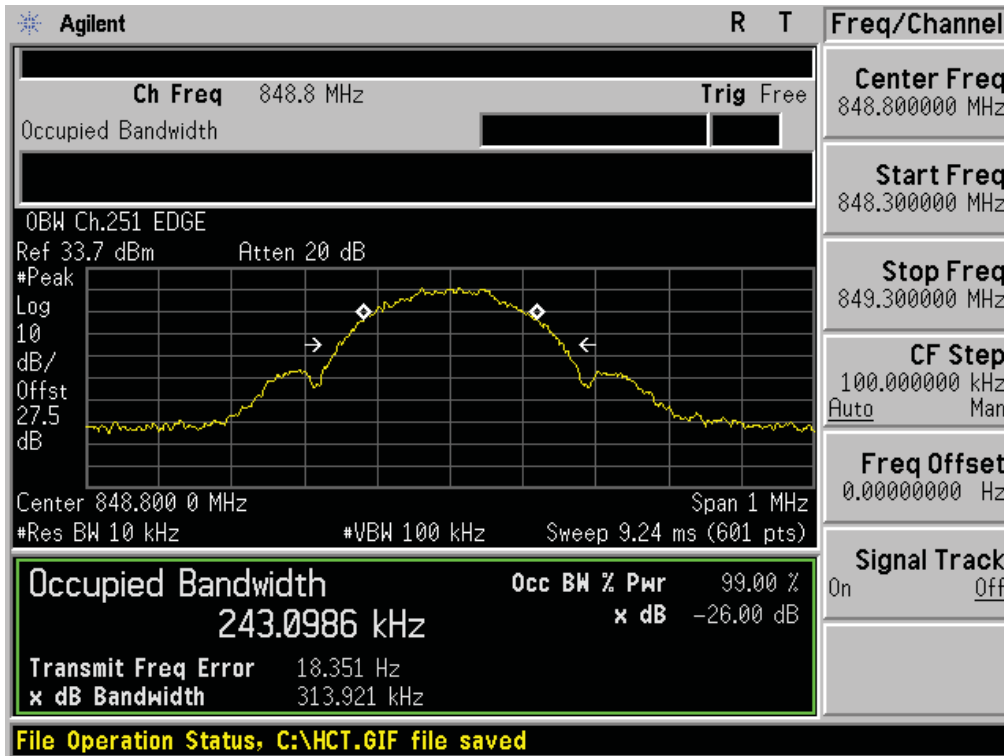

FCC CERTIFICATION REPORT

Test Report No. HCTR1210FR05-3	Date of Issue: November 14, 2012	EUT Type: CDMA/GSM/WCDMA/LTE Telematics	www.hct.co.kr FCC ID: BEJLTC10N
-----------------------------------	-------------------------------------	--	--

■ GSM1900 MODE (512 CH.) Occupied Bandwidth

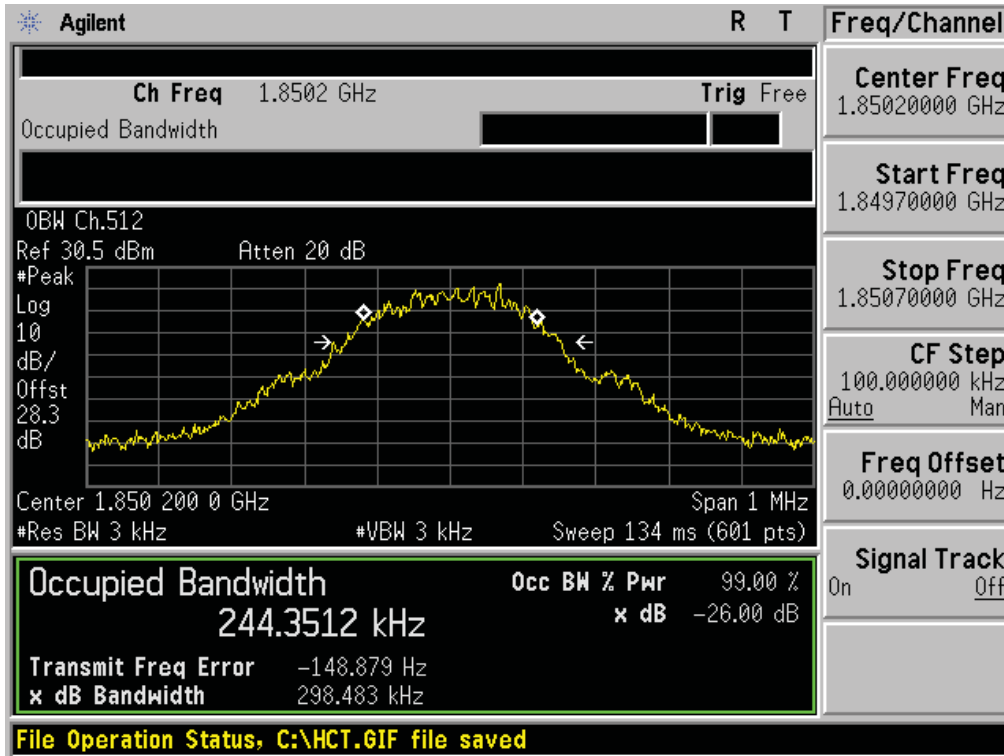

■ GSM1900 MODE (661 CH.) Occupied Bandwidth

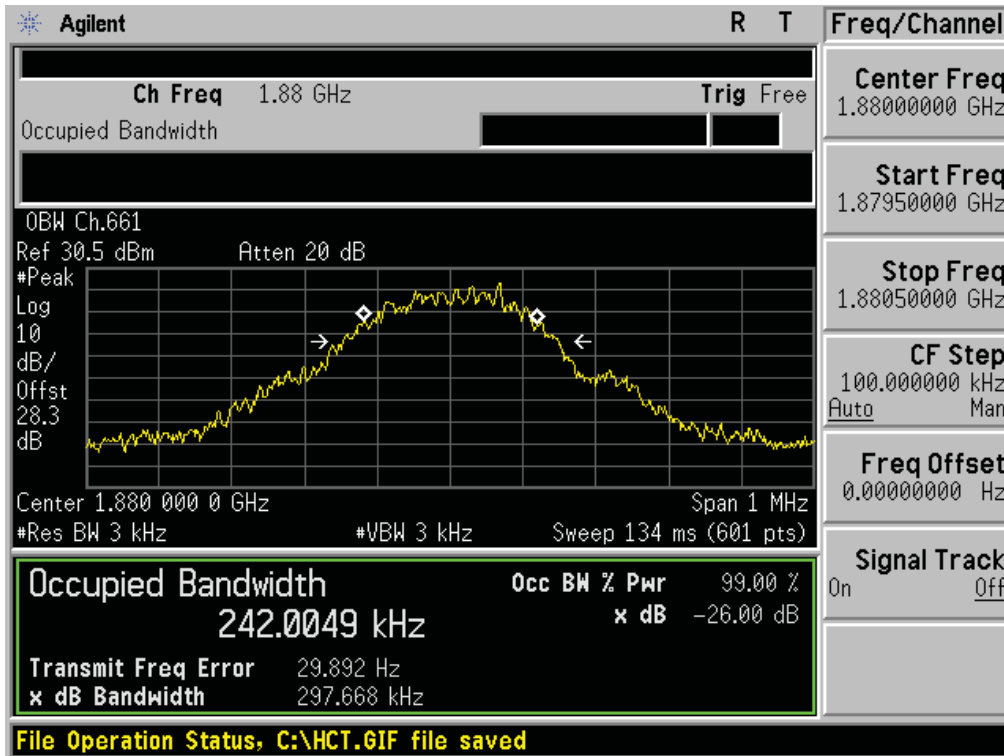

FCC CERTIFICATION REPORT

Test Report No. HCTR1210FR05-3	Date of Issue: November 14, 2012	EUT Type: CDMA/GSM/WCDMA/LTE Telematics	www.hct.co.kr FCC ID: BEJLTC10N
-----------------------------------	-------------------------------------	--	--

■ GSM1900 MODE (810 CH.) Occupied Bandwidth

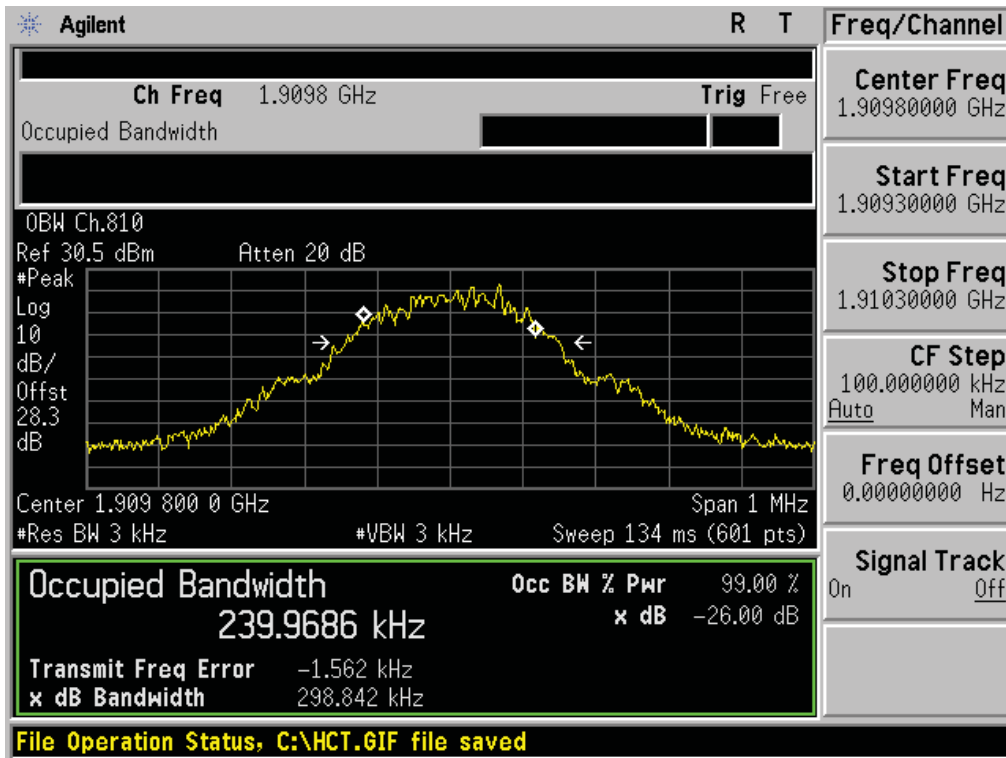

■ GSM1900 EDGE (512 CH.) Occupied Bandwidth

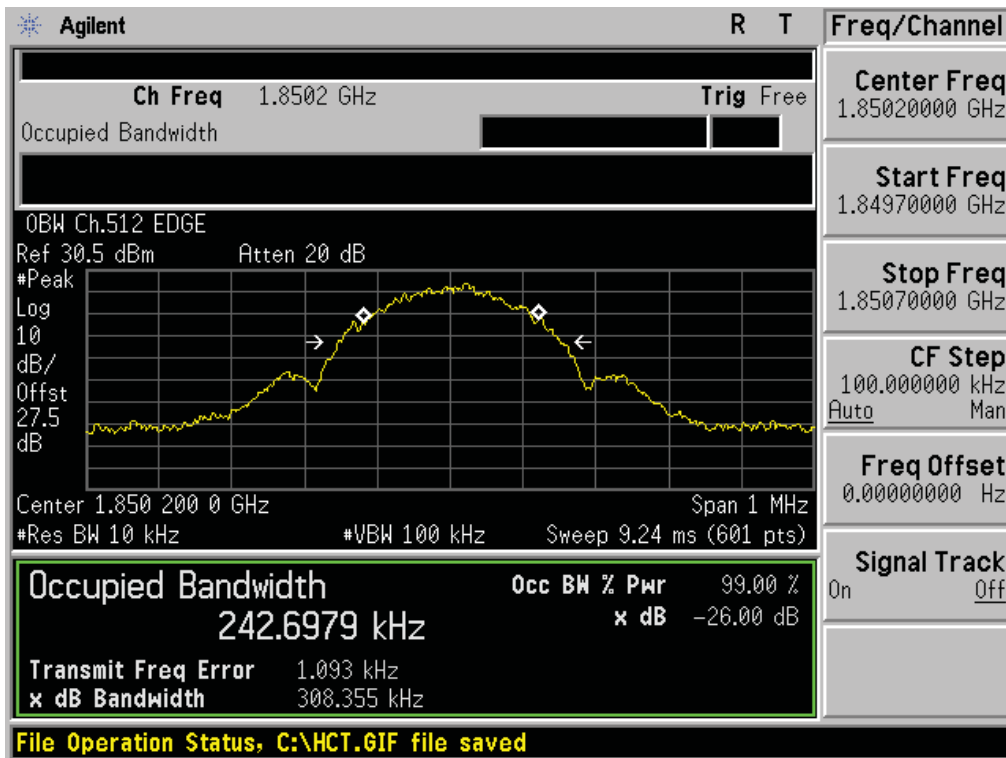

■ GSM1900 MODE (661 CH.) Peak-to-Average Ratio

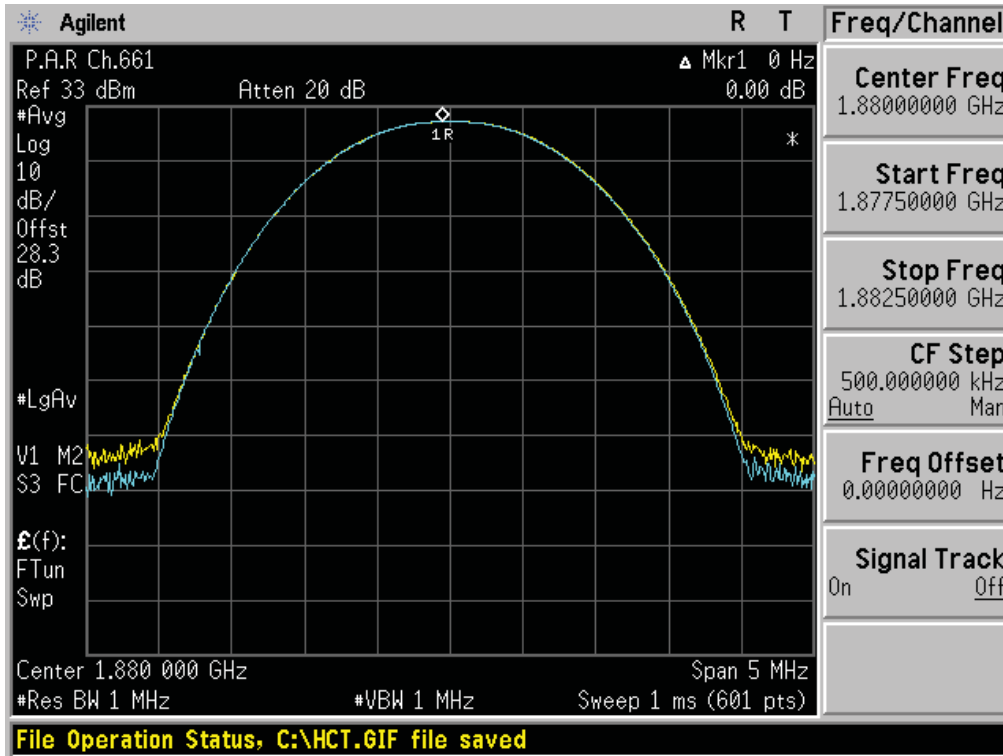

■ GSM1900 EDGE (661 CH.) Peak-to-Average Ratio

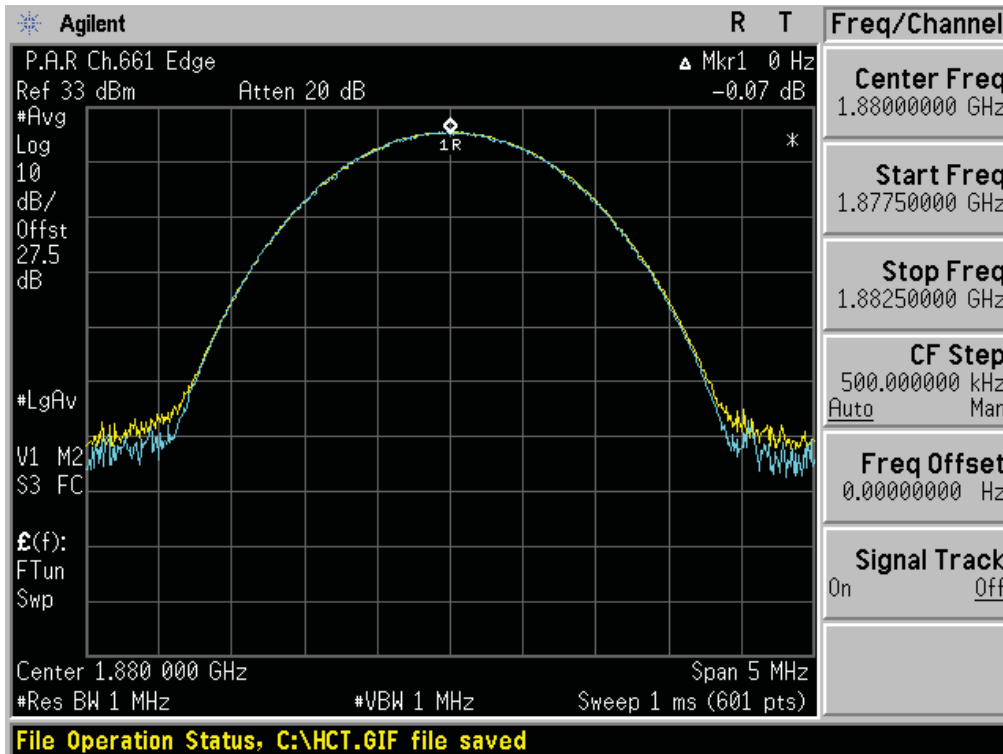

FCC CERTIFICATION REPORT

FCC CERTIFICATION REPORT			www.hct.co.kr
Test Report No. HCTR1210FR05-3	Date of Issue: November 14, 2012	EUT Type: CDMA/GSM/WCDMA/LTE Telematics	FCC ID: BEJLTC10N

■ WCDMA850 MODE (4132 CH.) Occupied Bandwidth

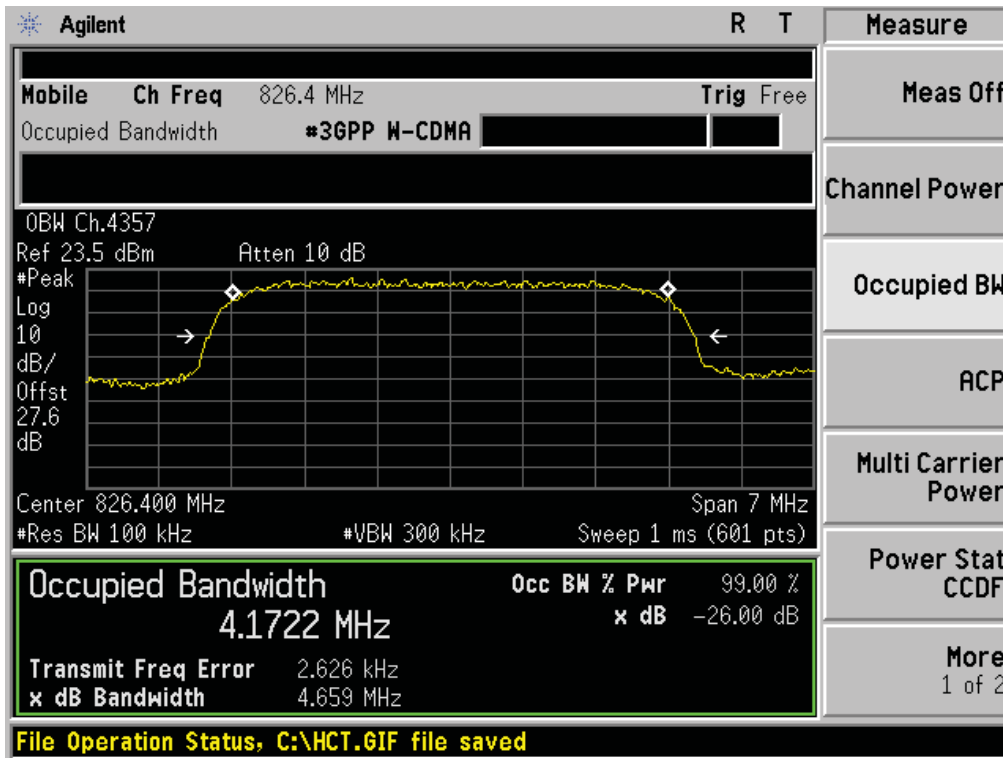

■ WCDMA850 MODE (4183 CH.) Occupied Bandwidth

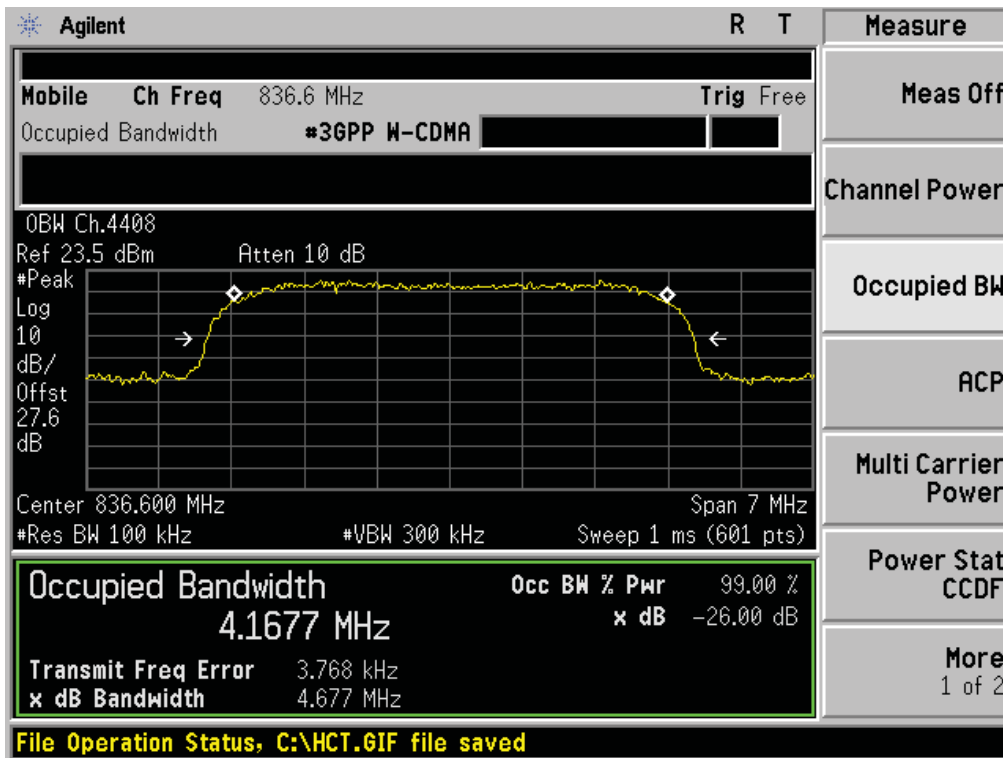

FCC CERTIFICATION REPORT

Test Report No. HCTR1210FR05-3	Date of Issue: November 14, 2012	EUT Type: CDMA/GSM/WCDMA/LTE Telematics	www.hct.co.kr FCC ID: BEJLTC10N
-----------------------------------	-------------------------------------	--	--

■ WCDMA850MODE (4233 CH.) Occupied Bandwidth

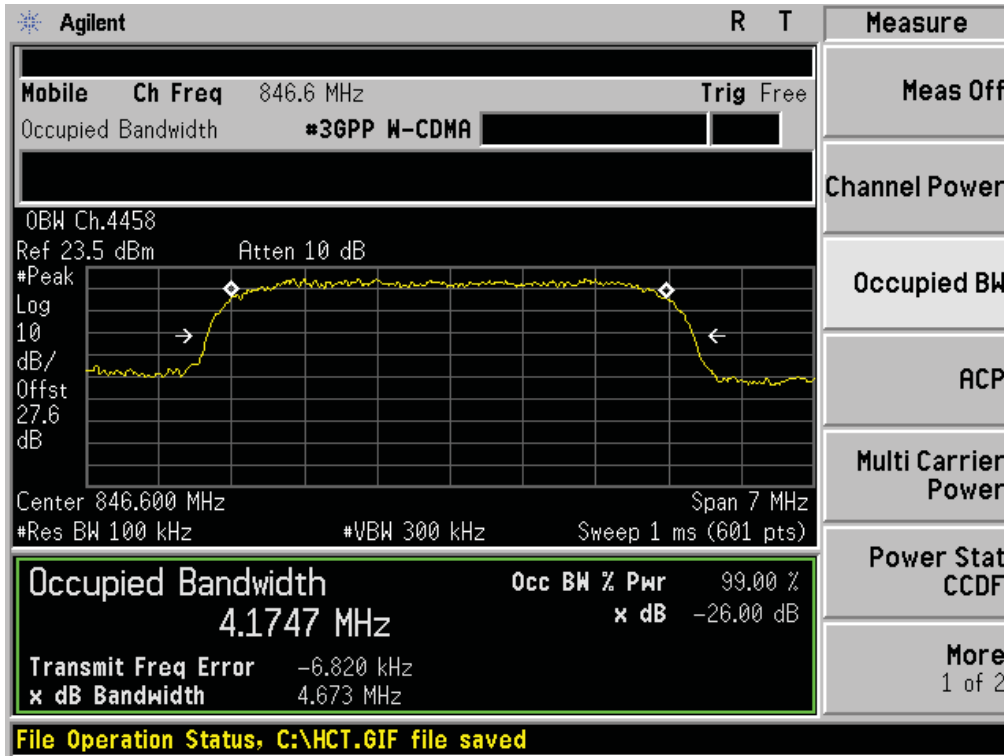

■ WCDMA1900 MODE (9262 CH.) Occupied Bandwidth

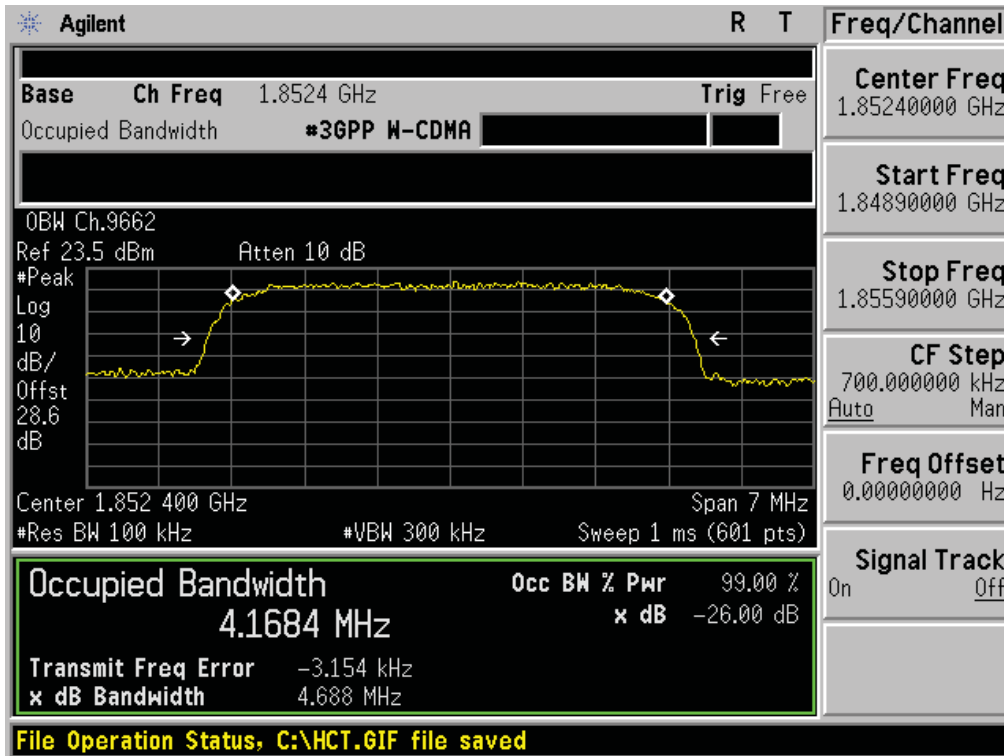

FCC CERTIFICATION REPORT

FCC CERTIFICATION REPORT			www.hct.co.kr
Test Report No. HCTR1210FR05-3	Date of Issue: November 14, 2012	EUT Type: CDMA/GSM/WCDMA/LTE Telematics	FCC ID: BEJLTC10N

■ WCDMA1900 MODE (9400 CH.) Occupied Bandwidth

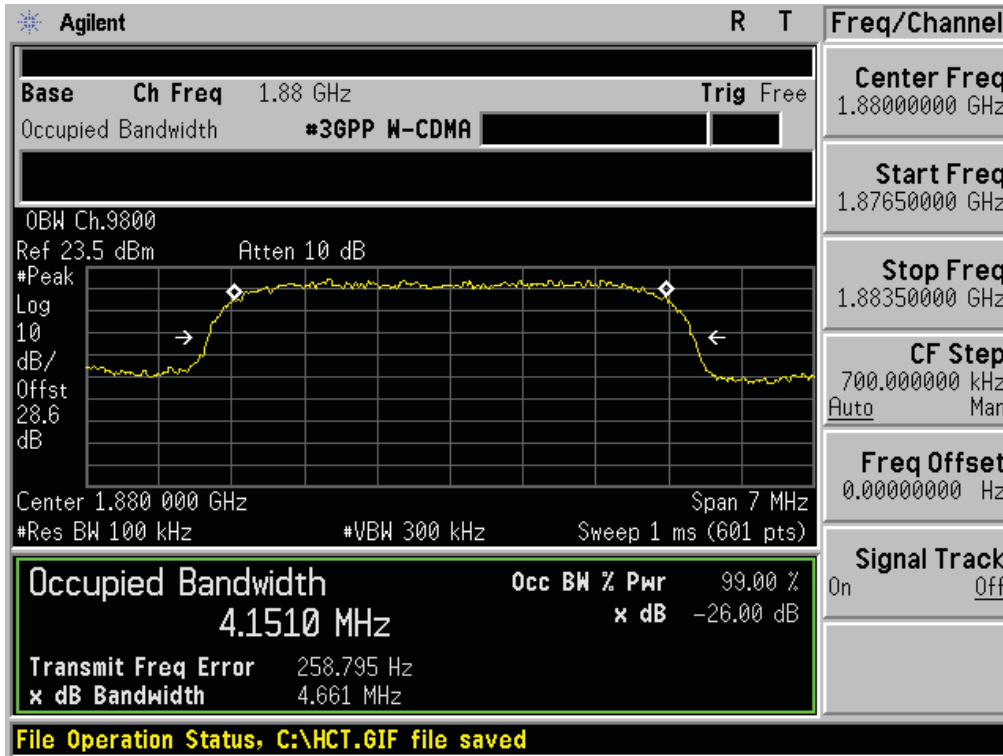

■ WCDMA1900 MODE (9538 CH.) Occupied Bandwidth

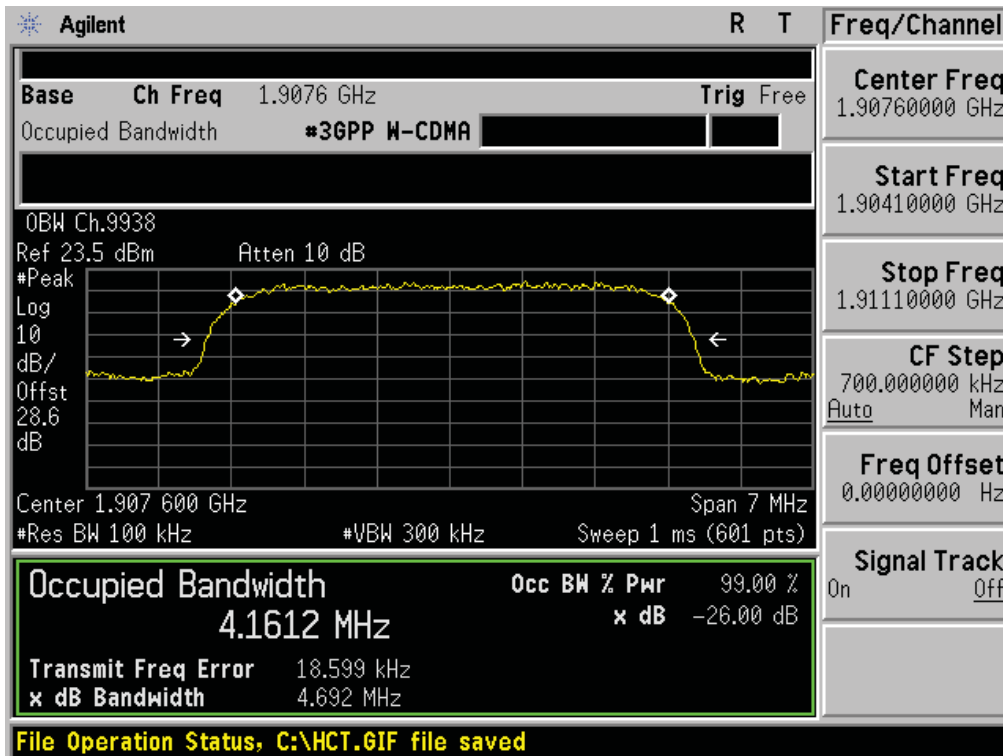

FCC CERTIFICATION REPORT

Test Report No. HCTR1210FR05-3	Date of Issue: November 14, 2012	EUT Type: CDMA/GSM/WCDMA/LTE Telematics	www.hct.co.kr
			FCC ID: BEJLTC10N

■ WCDMA1700 MODE (1312 CH.) Occupied Bandwidth

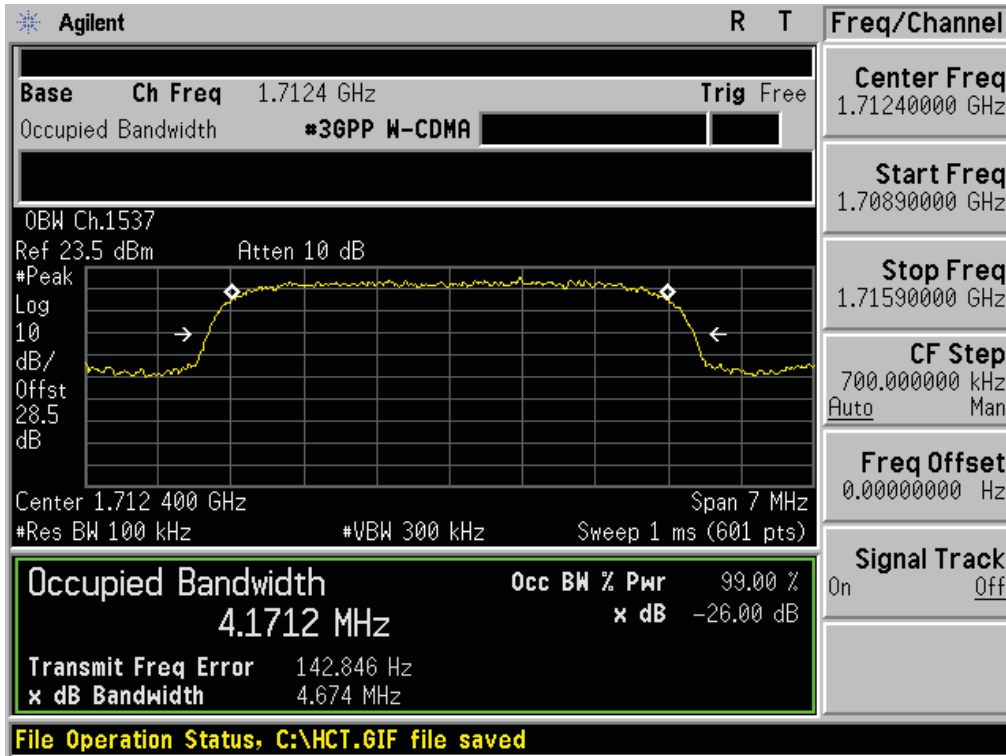

■ WCDMA1700 MODE (1412 CH.) Occupied Bandwidth

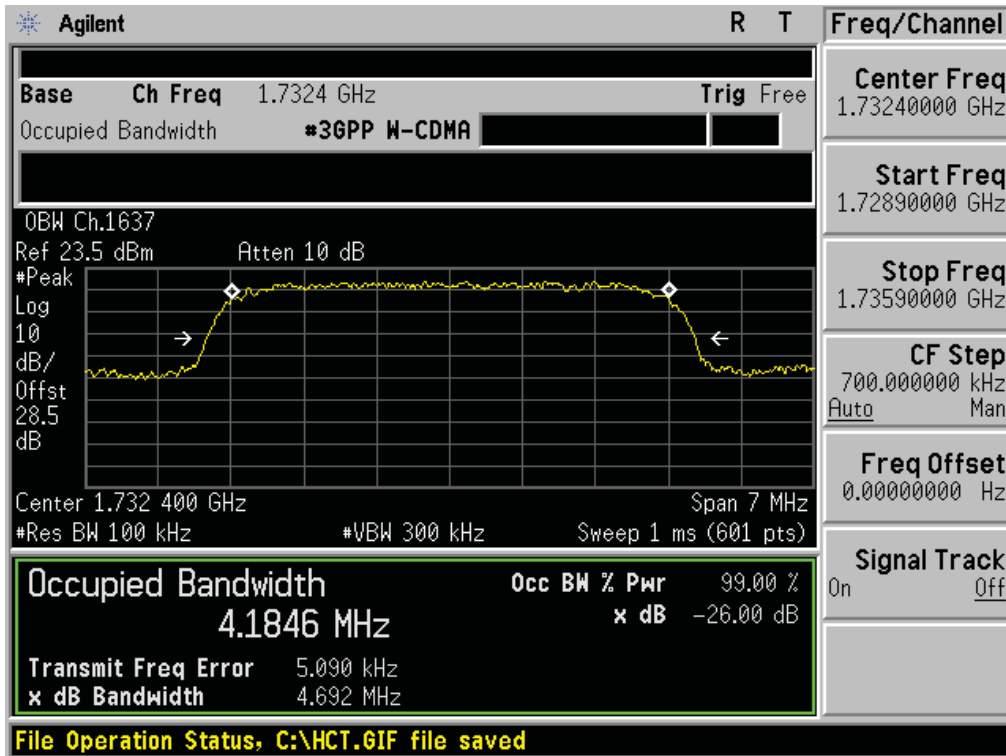

FCC CERTIFICATION REPORT

Test Report No. HCTR1210FR05-3	Date of Issue: November 14, 2012	EUT Type: CDMA/GSM/WCDMA/LTE Telematics	www.hct.co.kr FCC ID: BEJLTC10N
-----------------------------------	-------------------------------------	--	--

■ WCDMA1700 MODE (1513 CH.) Occupied Bandwidth

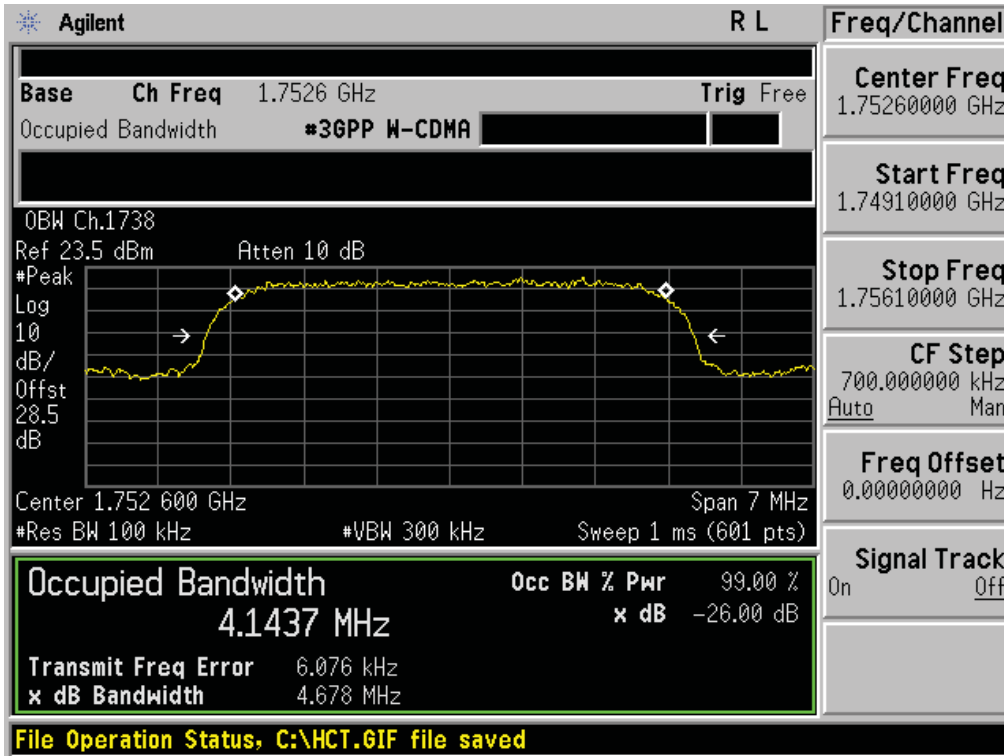

■ WCDMA1700 MODE (1412 CH.) Peak-to-Average Ratio

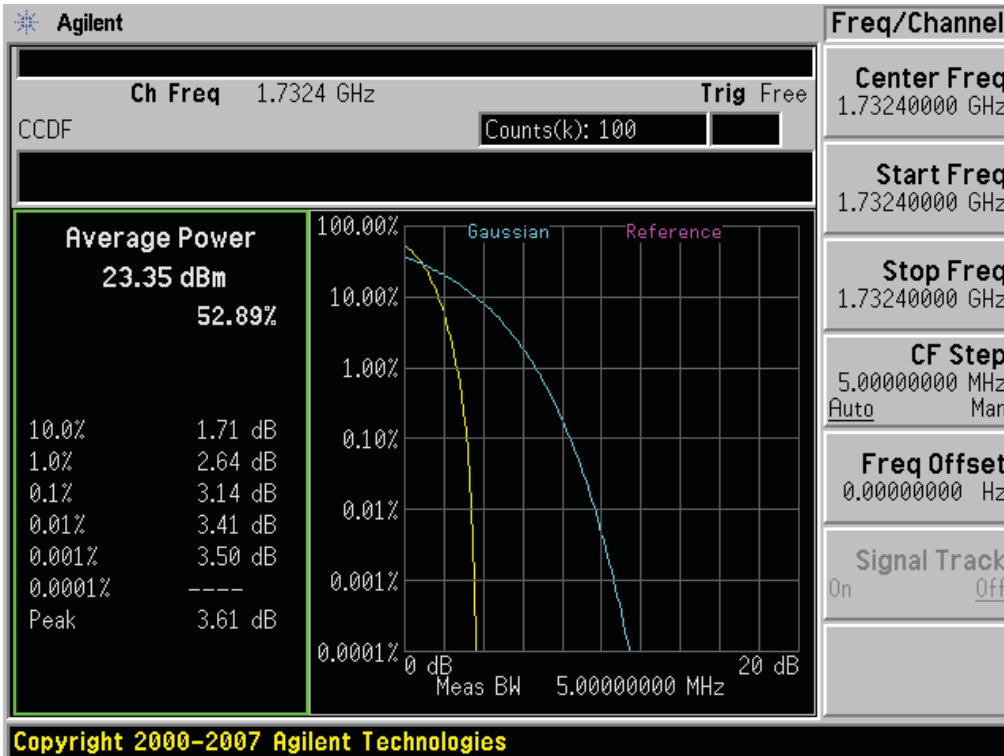

■ WCDMA1900 MODE (9400 CH.) Peak-to-Average Ratio

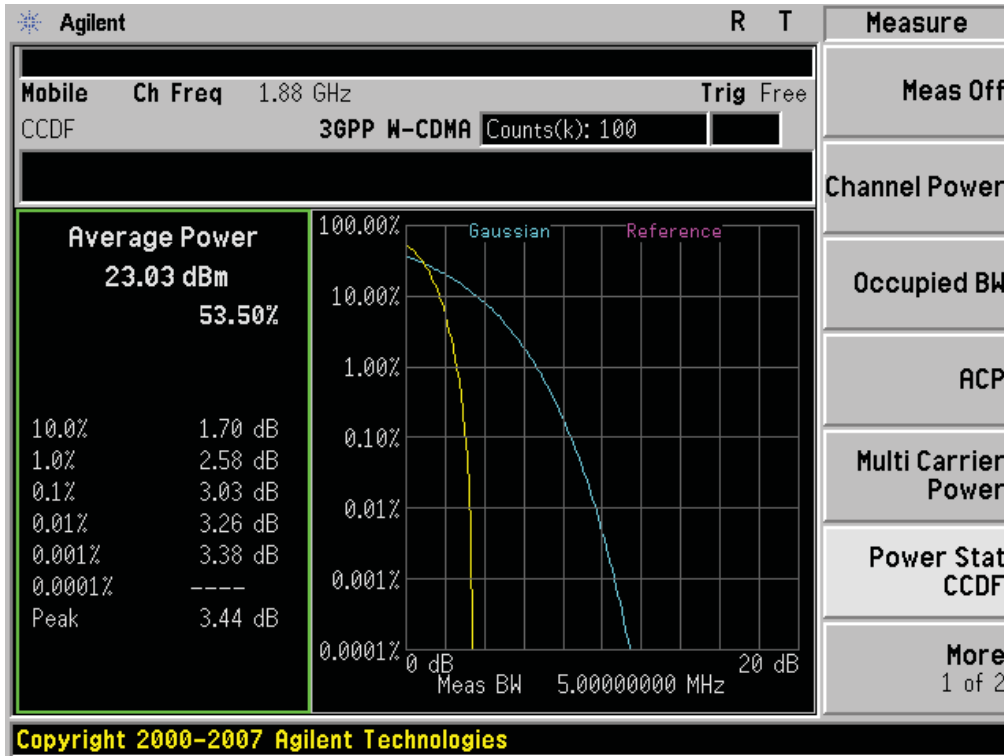

■ GSM850 MODE (128 CH.) Block Edge 1

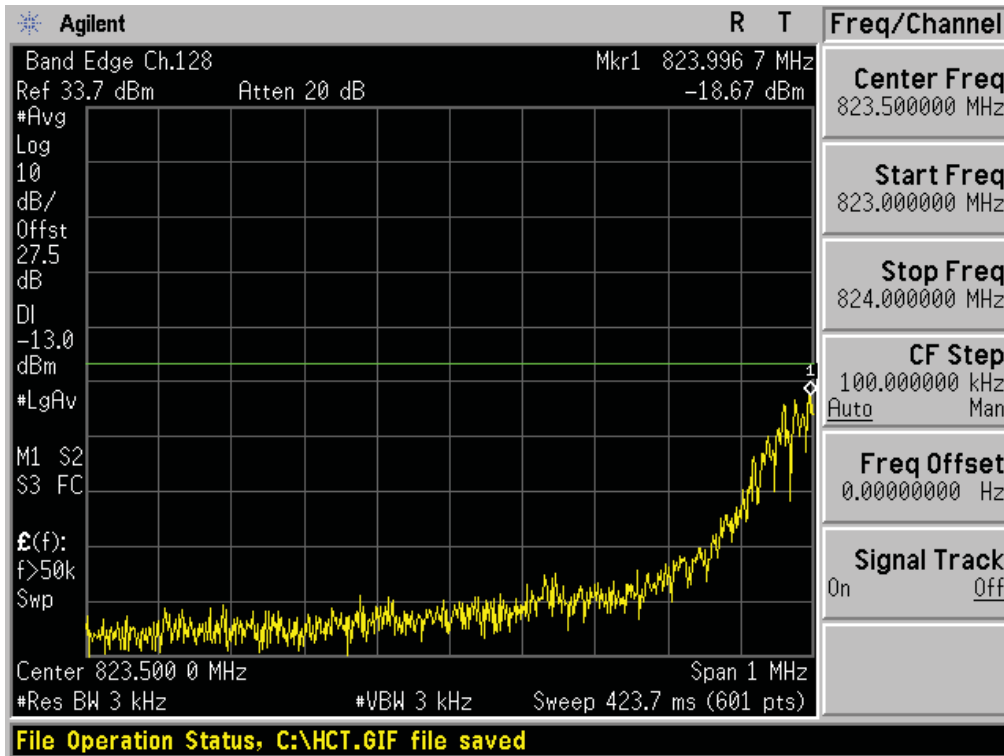

■ GSM850 MODE (128 CH.) Block Edge 2

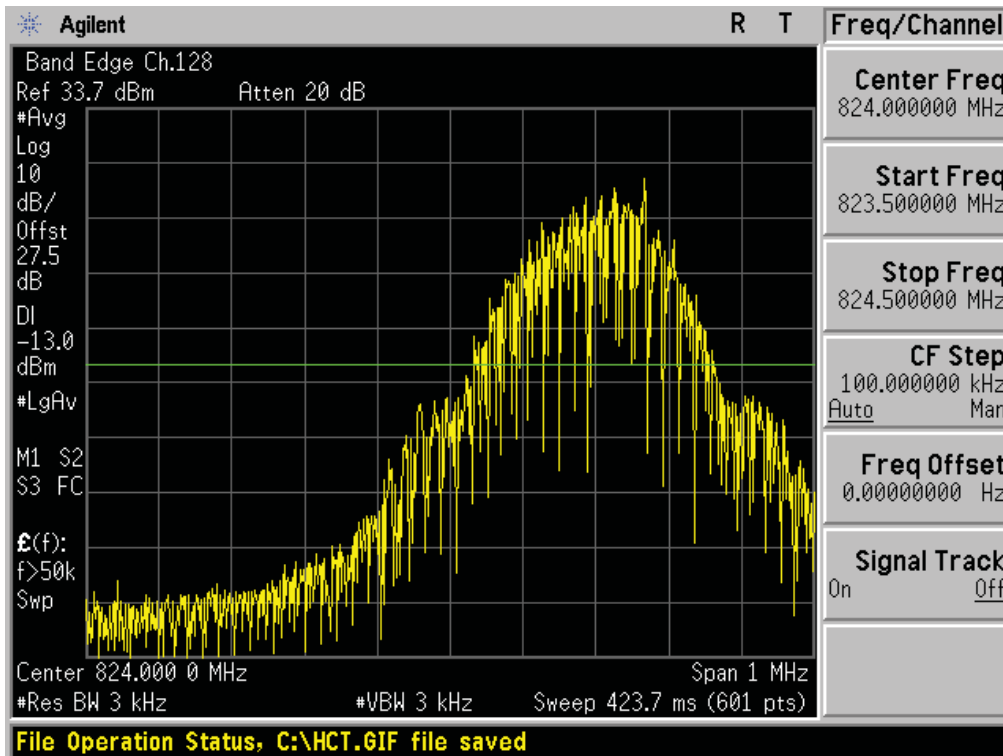

■ GSM850 MODE (251 CH.) Block Edge 1

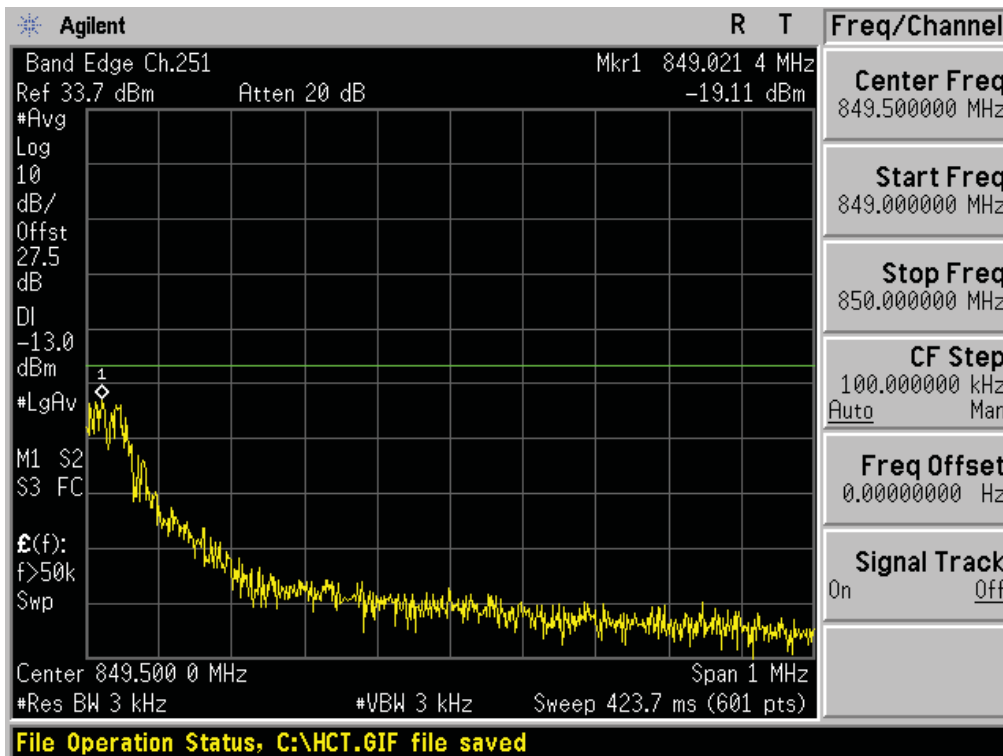

FCC CERTIFICATION REPORT

Test Report No. HCTR1210FR05-3	Date of Issue: November 14, 2012	EUT Type: CDMA/GSM/WCDMA/LTE Telematics	www.hct.co.kr FCC ID: BEJLTC10N
-----------------------------------	-------------------------------------	--	--

■ GSM850 MODE (251 CH.) Block Edge 2

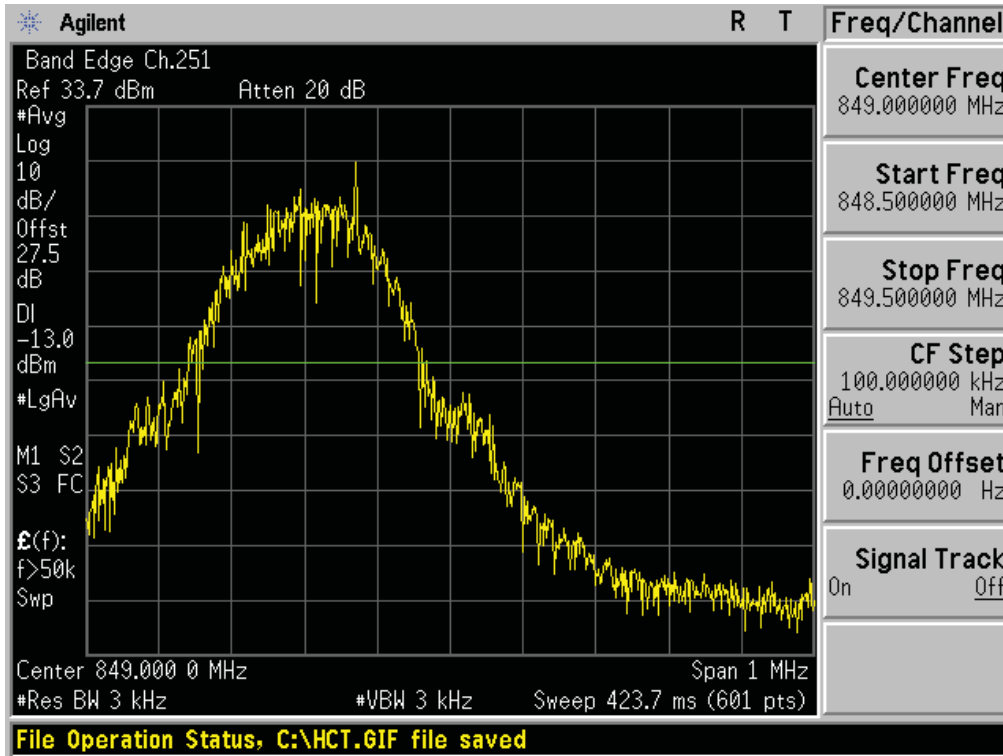

■ EDGE MODE (128 CH.) Block Edge 1

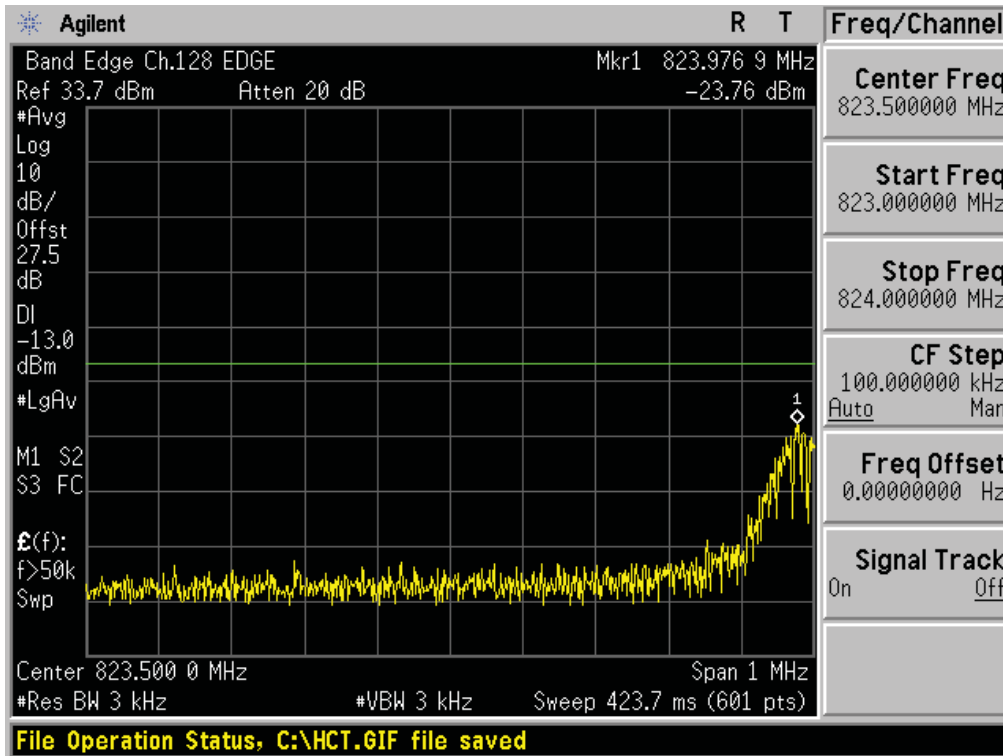

FCC CERTIFICATION REPORT			www.hct.co.kr
Test Report No. HCTR1210FR05-3	Date of Issue: November 14, 2012	EUT Type: CDMA/GSM/WCDMA/LTE Telematics	FCC ID: BEJLTC10N

■ EDGE MODE (128 CH.) Block Edge 2



■ EDGE MODE (251 CH.) Block Edge 1

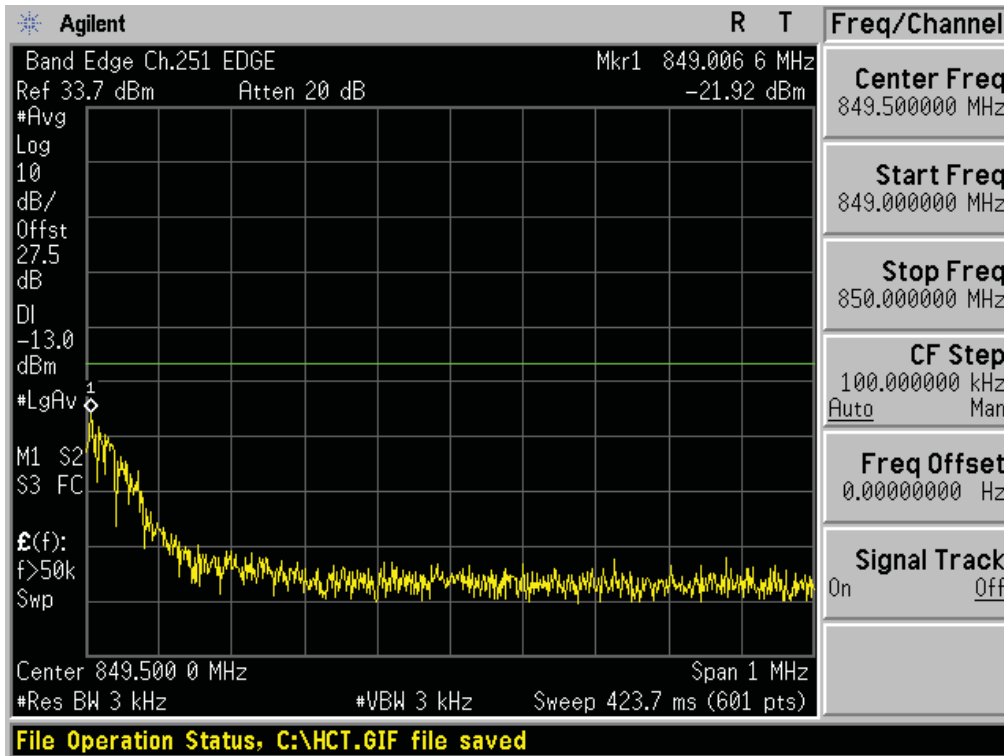

■ EDGE MODE (251 CH.) Block Edge 2

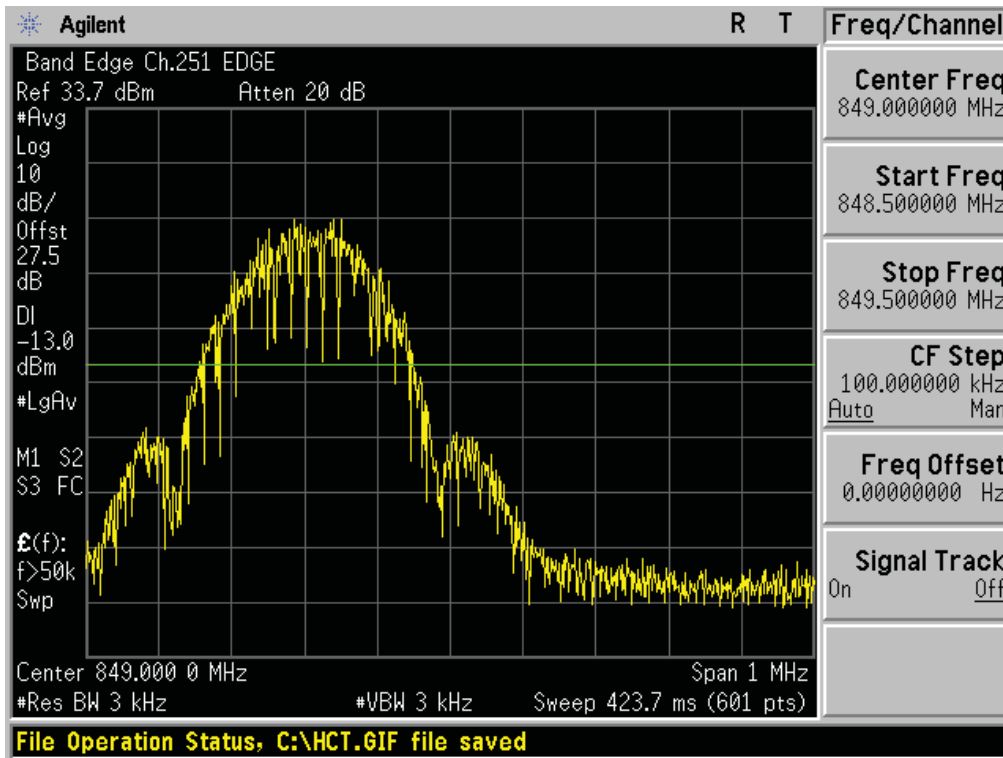

■ GSM1900 MODE (512 CH.) Block Edge 1

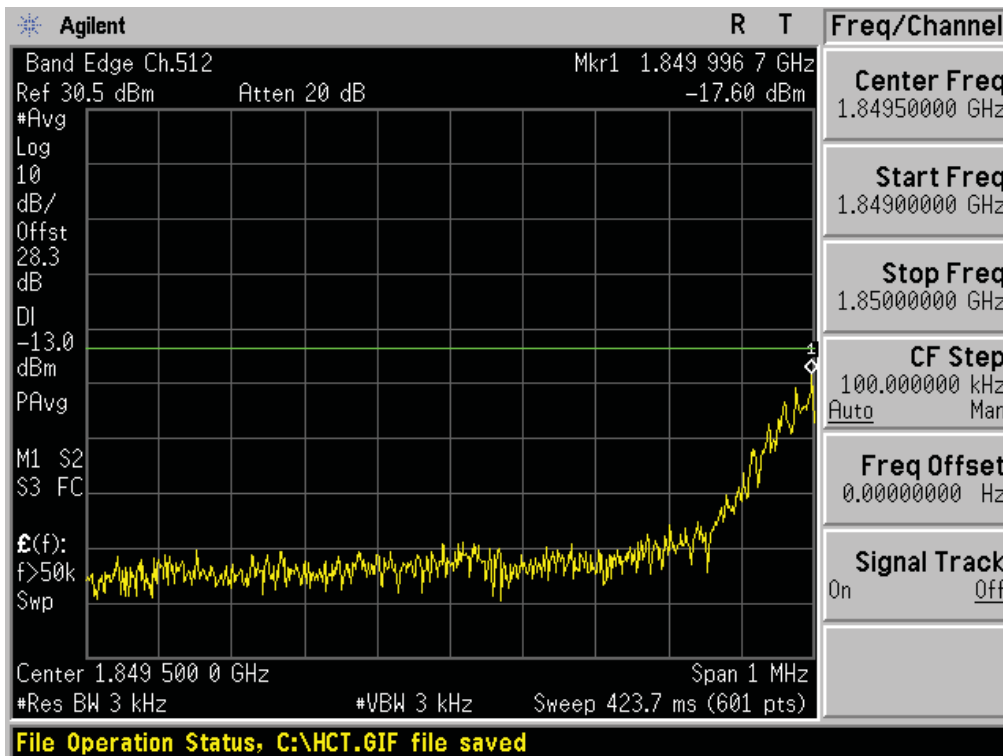

■ GSM1900 MODE (512 CH.) Block Edge 2

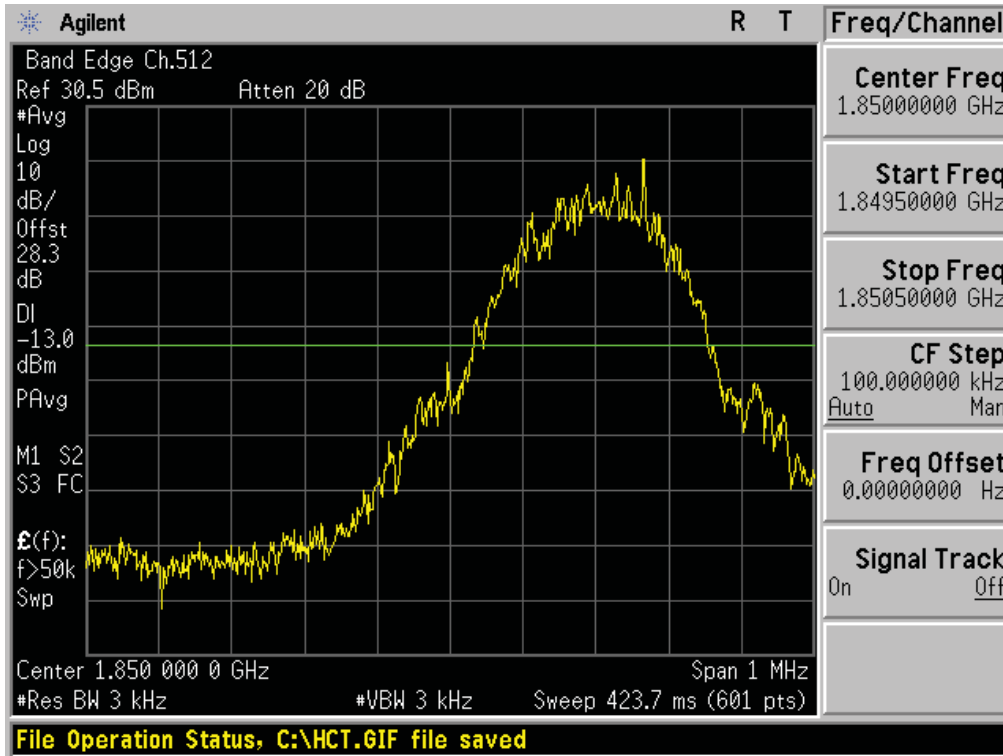

■ GSM1900 MODE (810 CH.) Block Edge 1

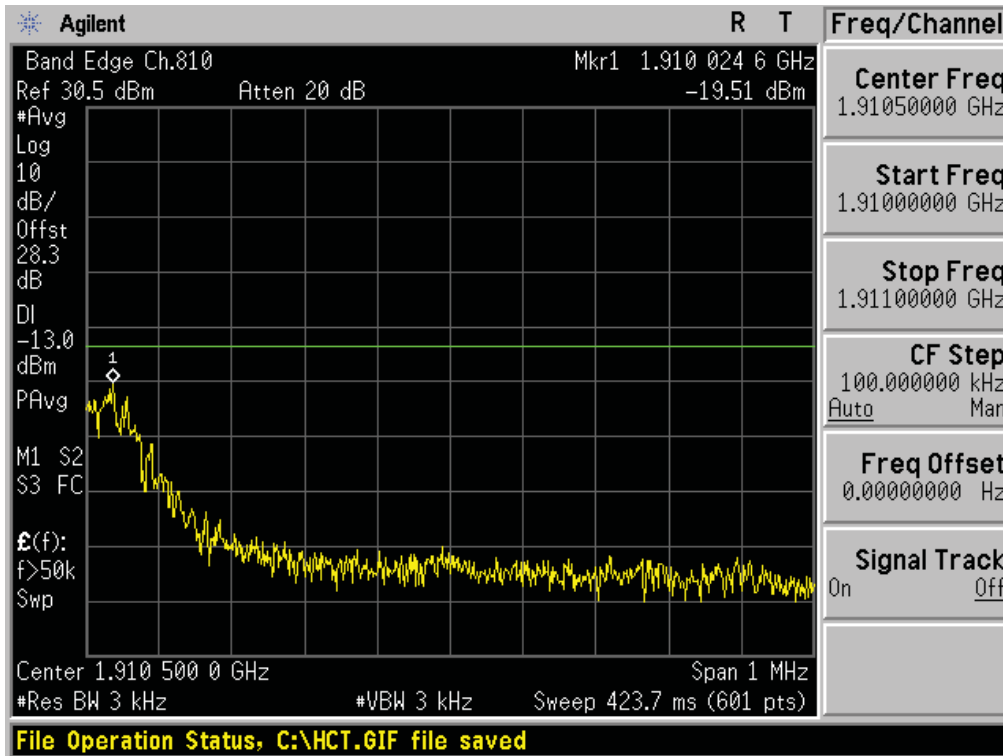

■ GSM1900 MODE (810 CH.) Block Edge 2

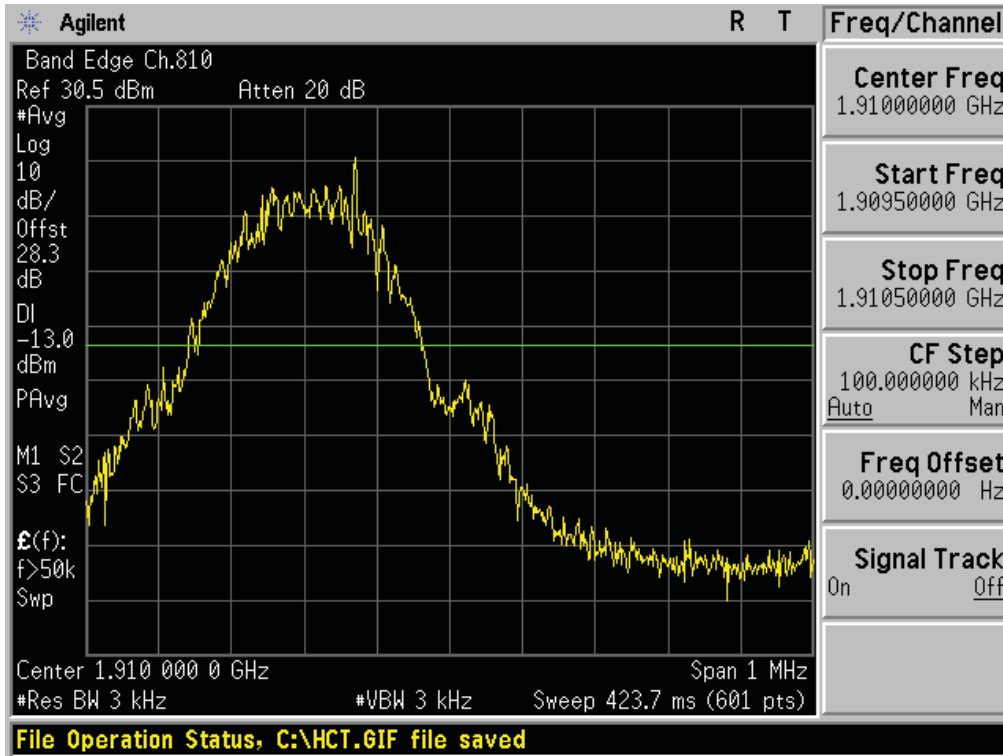

■ EDGE MODE (512 CH.) Block Edge 1

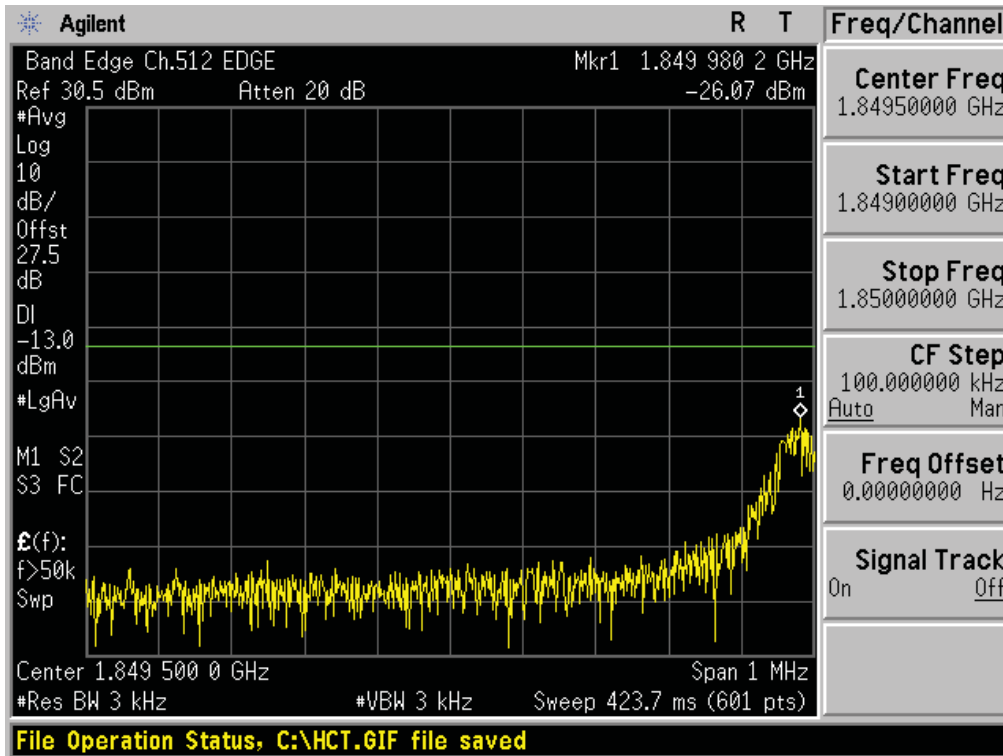

■ EDGE MODE (512 CH.) Block Edge 2

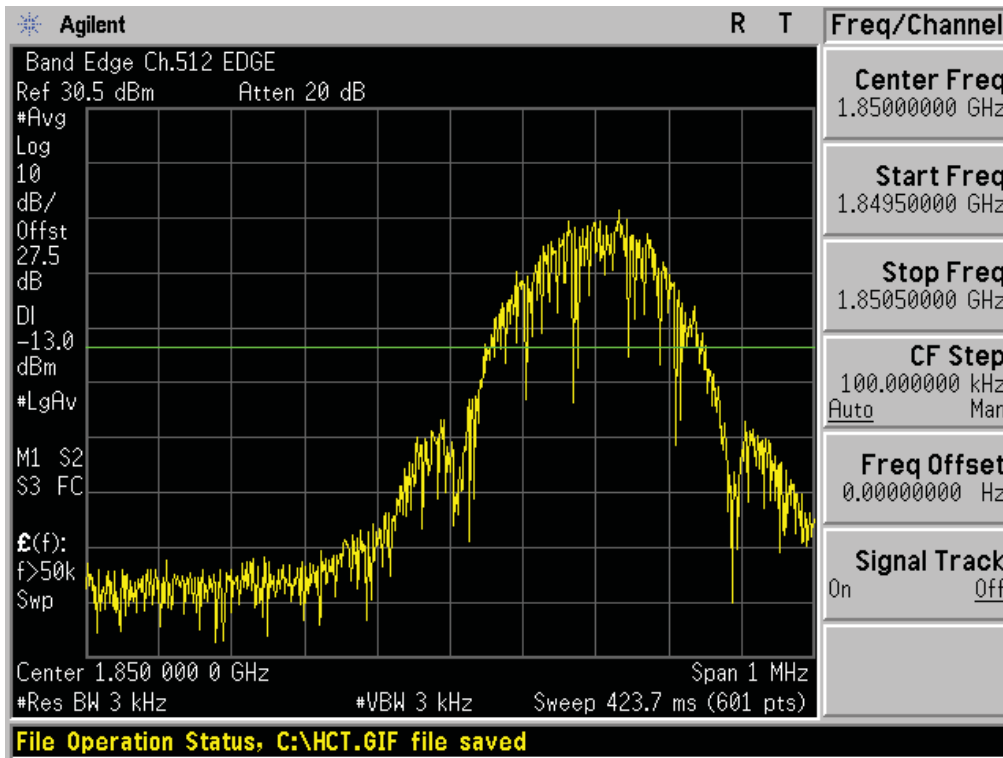

■ EDGE MODE (810 CH.) Block Edge 1

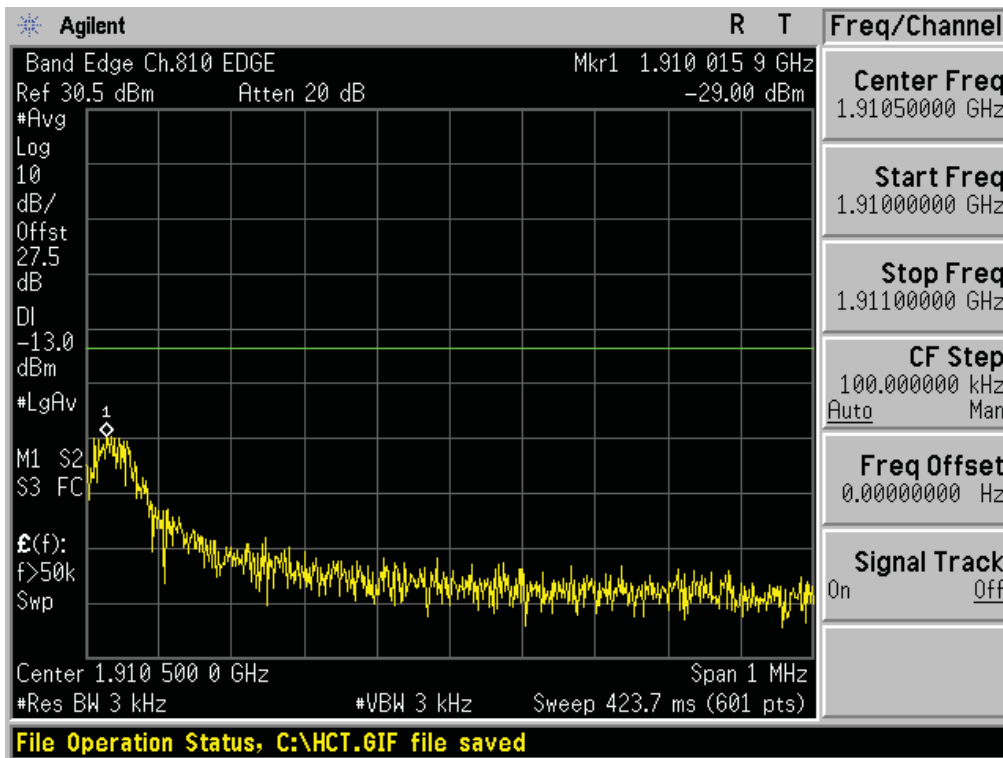

■ EDGE MODE (810 CH.) Block Edge 2

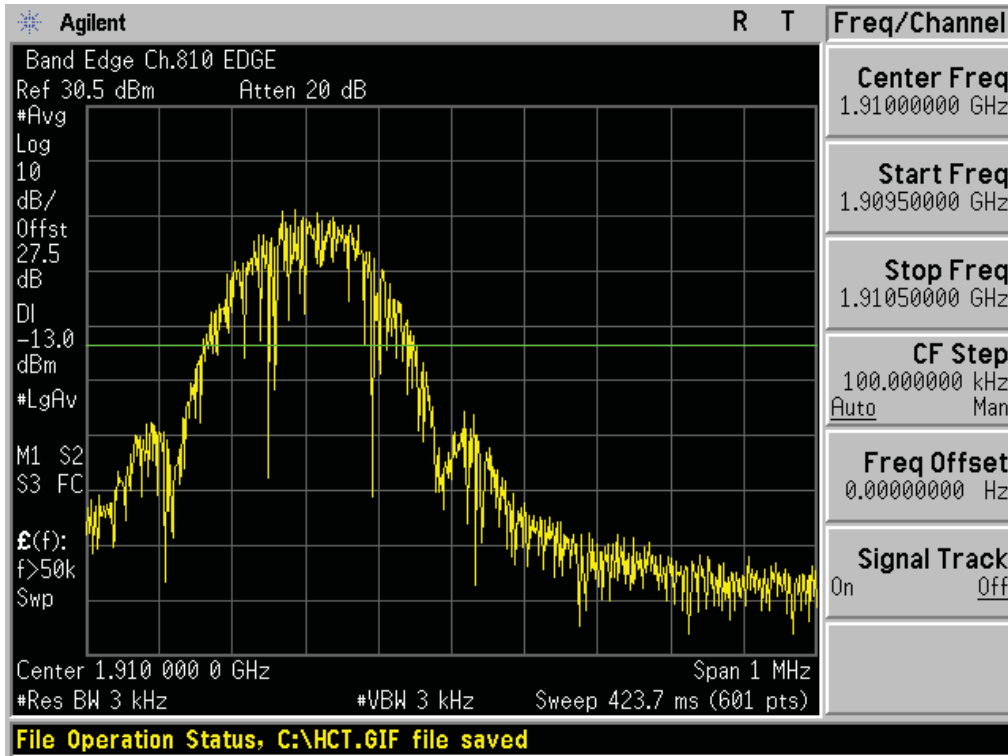

■ WCDMA850 MODE (4132 CH.) Block Edge

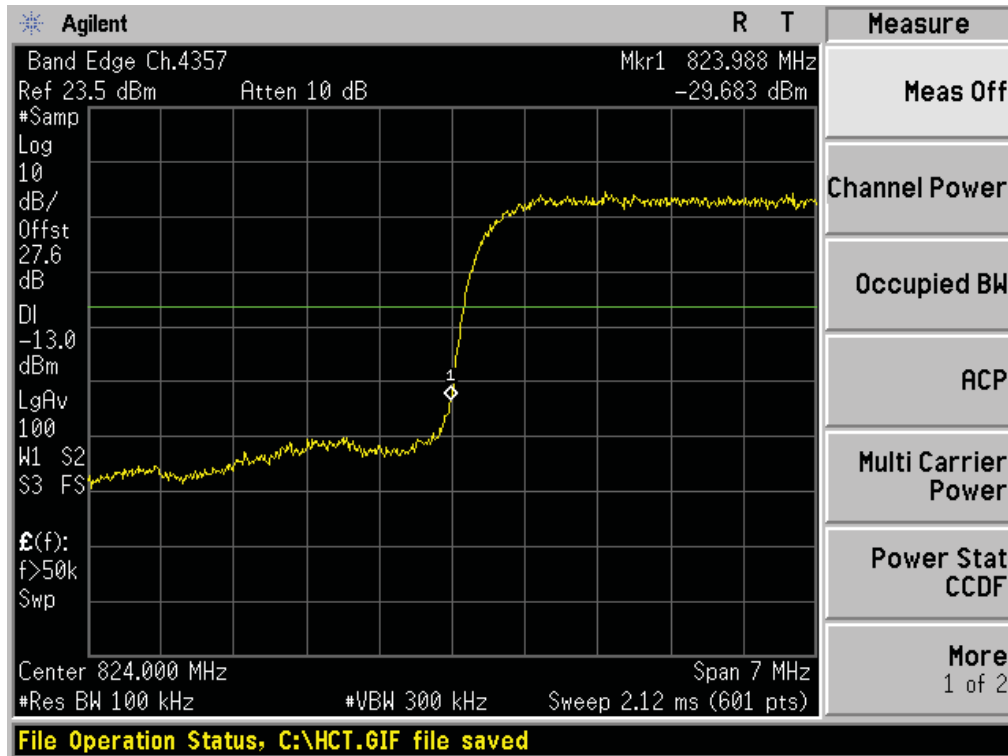

■ WCDMA850MODE (4233 CH.) Block Edge

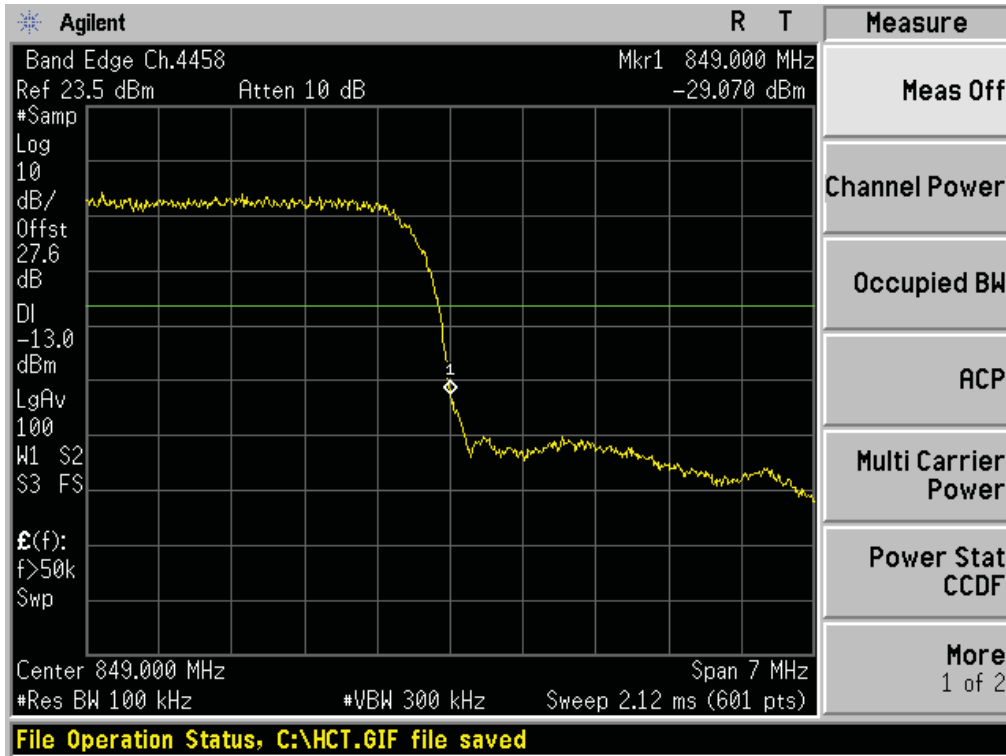

■ WCDMA850 MODE (4132 CH.) – 4 MHz Span

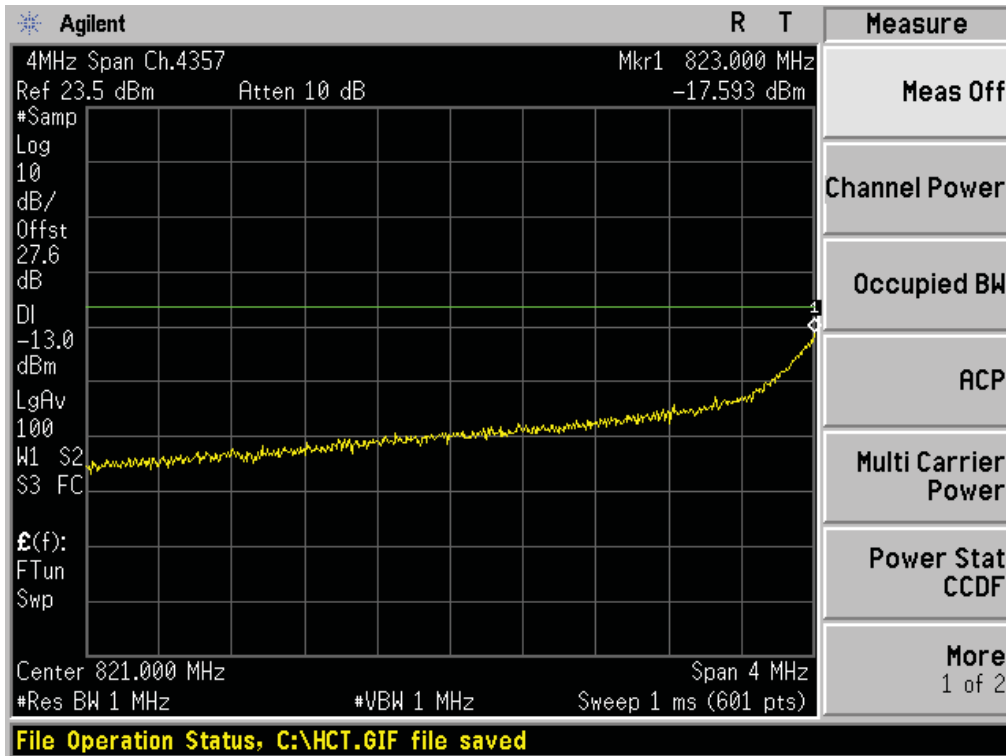

■ WCDMA850MODE (4233 CH.) – 4 MHz Span

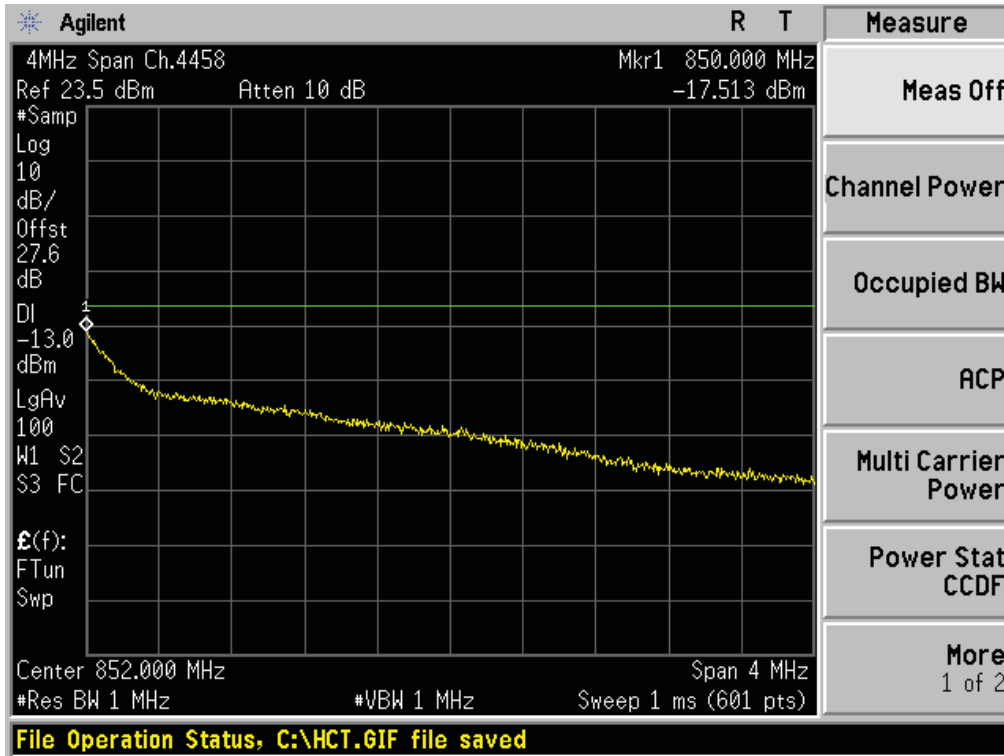

■ WCDMA1900 MODE (9262 CH.) Block Edge

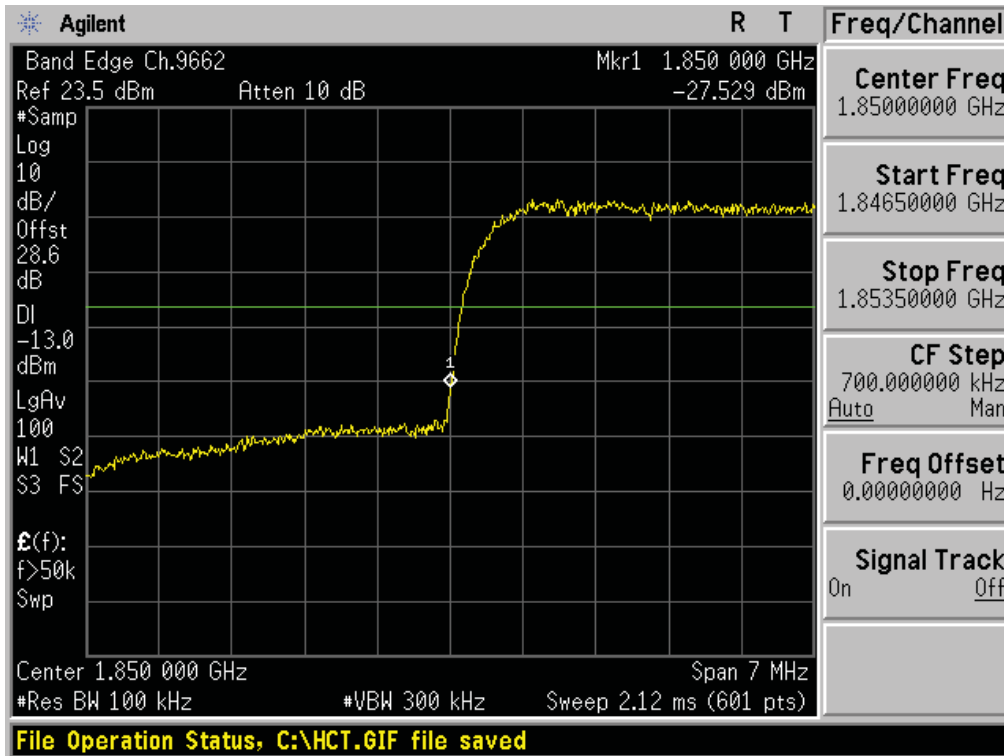

■ WCDMA1900 MODE (9538 CH.) Block Edge

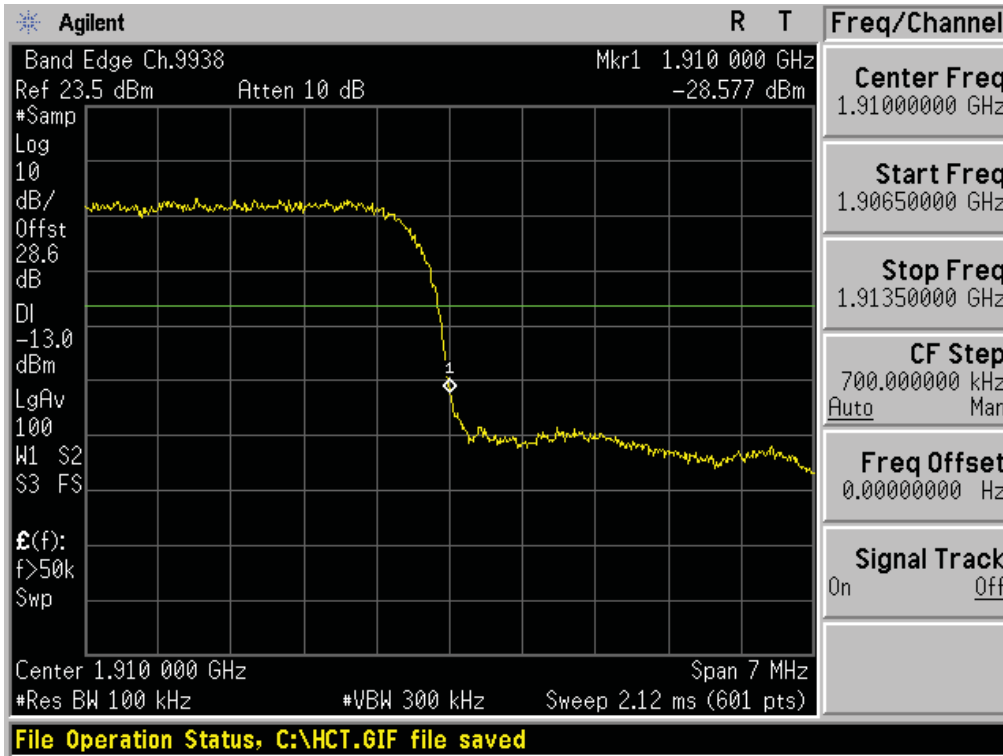

■ WCDMA1900 MODE (9262 CH.) – 4 MHz Span

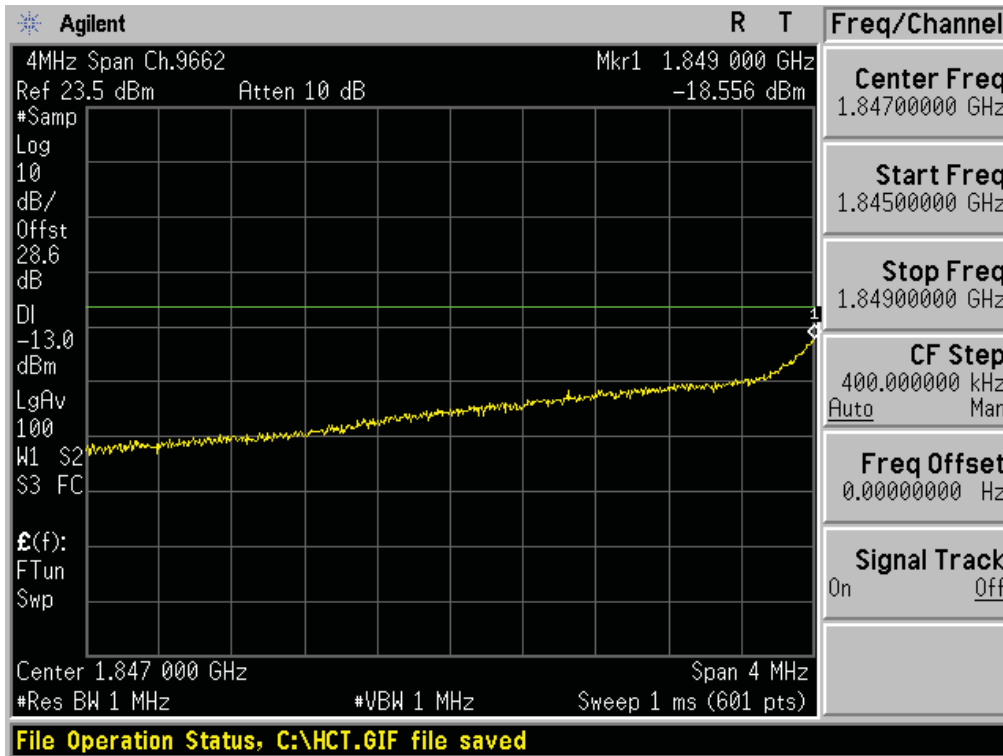

■ WCDMA1900 MODE (9538 CH.) – 4 MHz Span

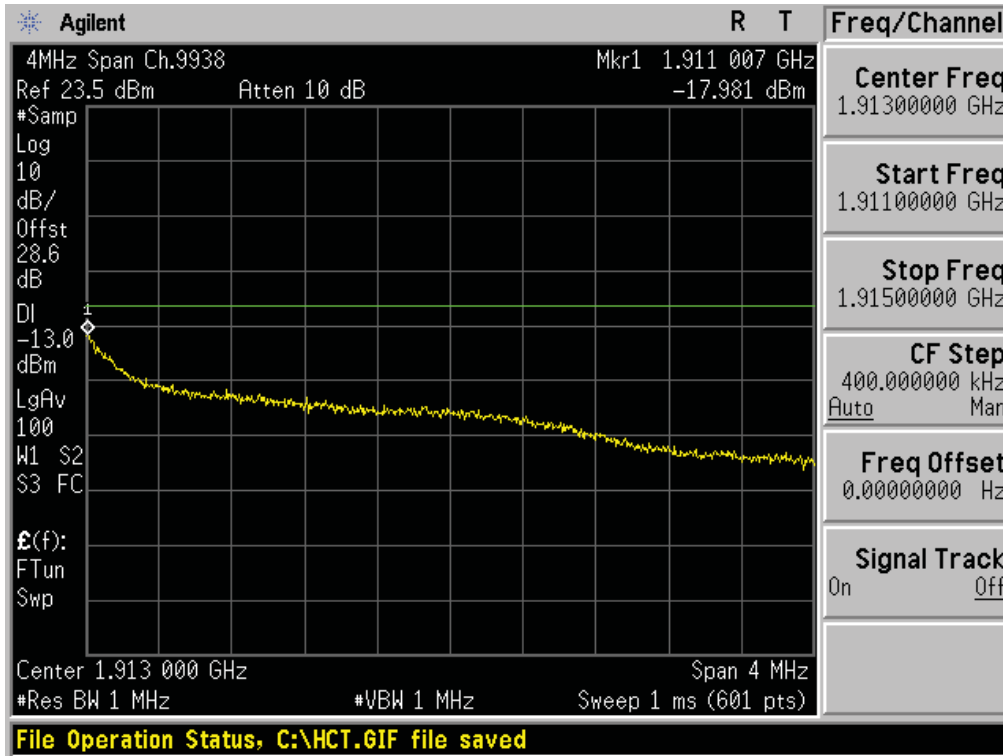

■ WCDMA1700 MODE (1312 CH.) Block Edge

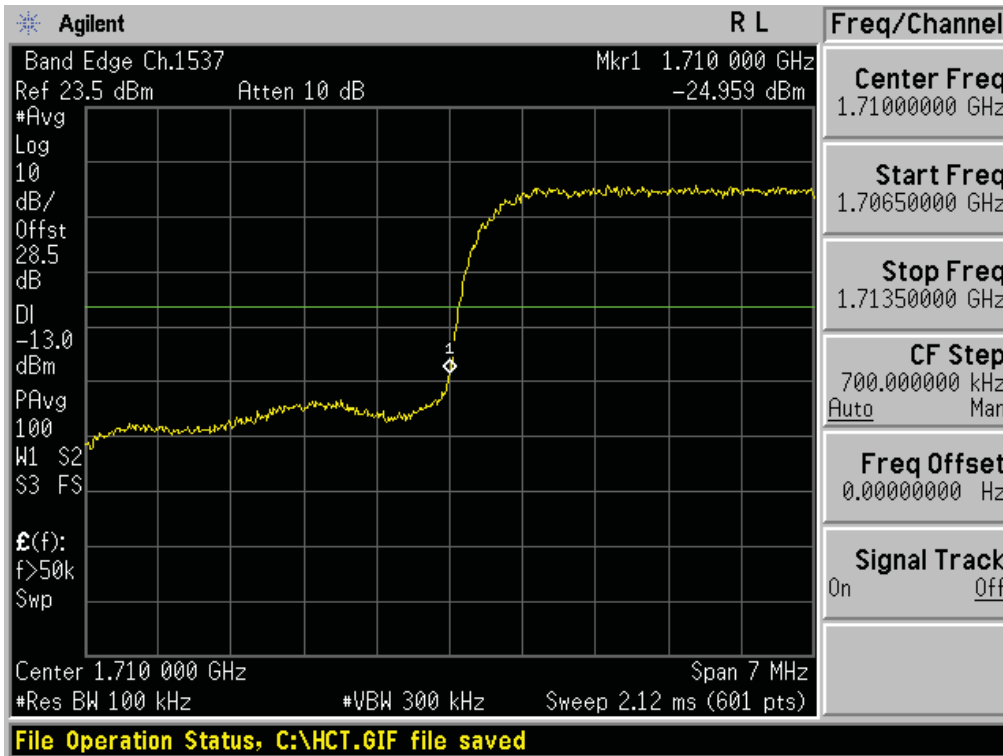

FCC CERTIFICATION REPORT

Test Report No. HCTR1210FR05-3	Date of Issue: November 14, 2012	EUT Type: CDMA/GSM/WCDMA/LTE Telematics	www.hct.co.kr FCC ID: BEJLTC10N
-----------------------------------	-------------------------------------	--	--

■ WCDMA1700 MODE (1513 CH.) Block Edge

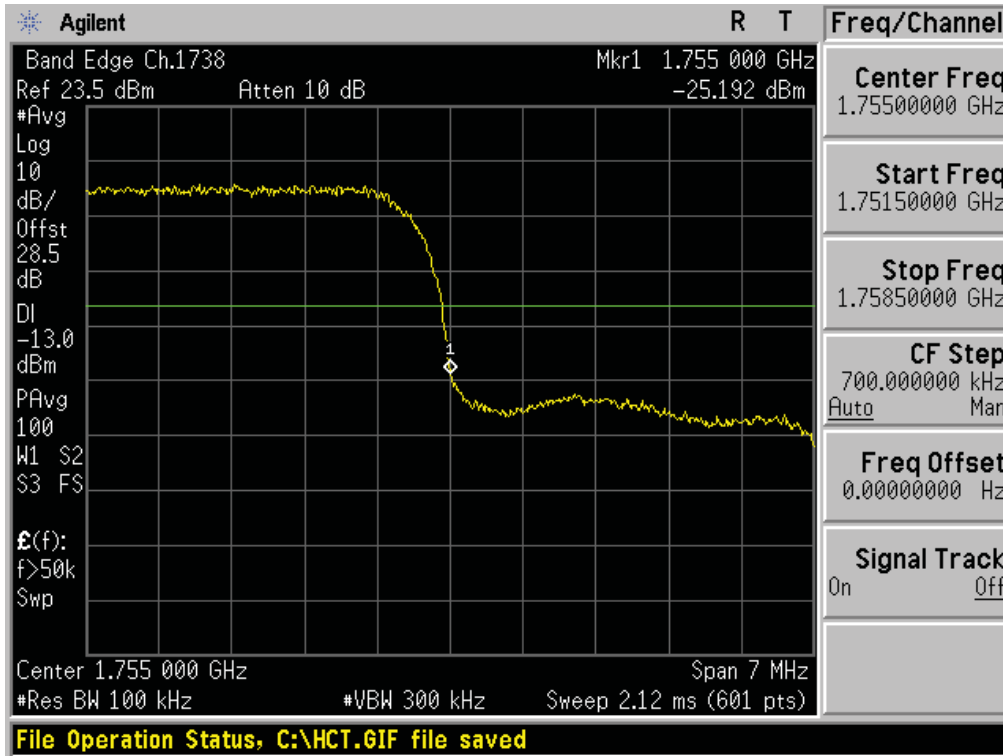

■ WCDMA1700 MODE (1312 CH.) – 4 MHz Span

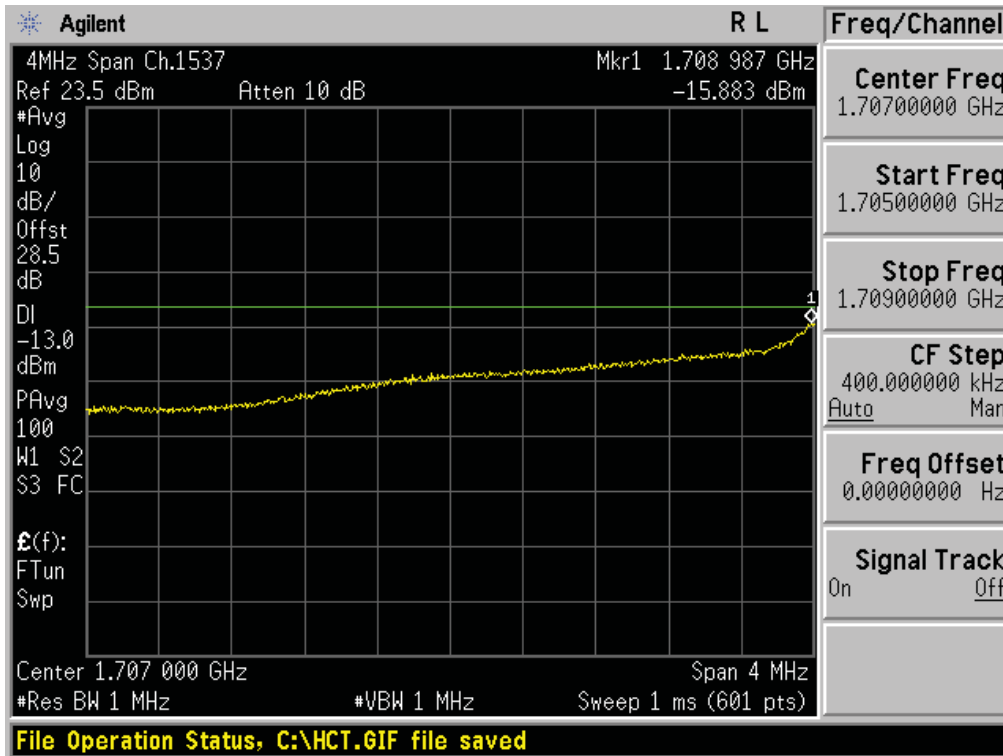

■ WCDMA1700 MODE (1513 CH.) – 4 MHz Span

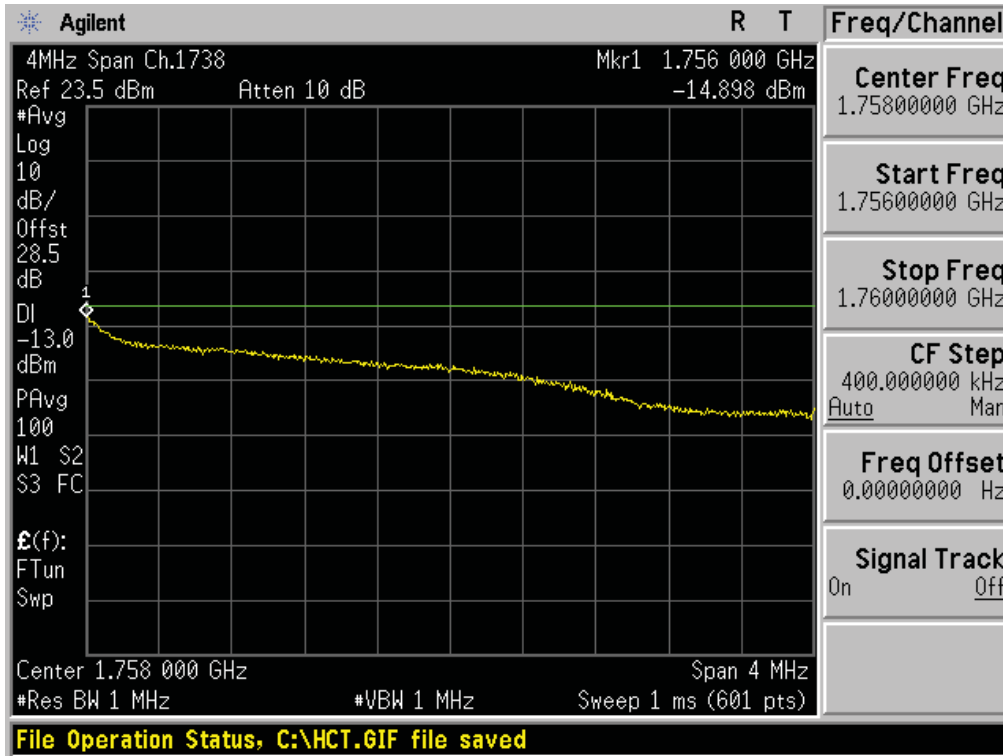

■ GSM850 MODE (128 CH.) Conducted Spurious Emissions1

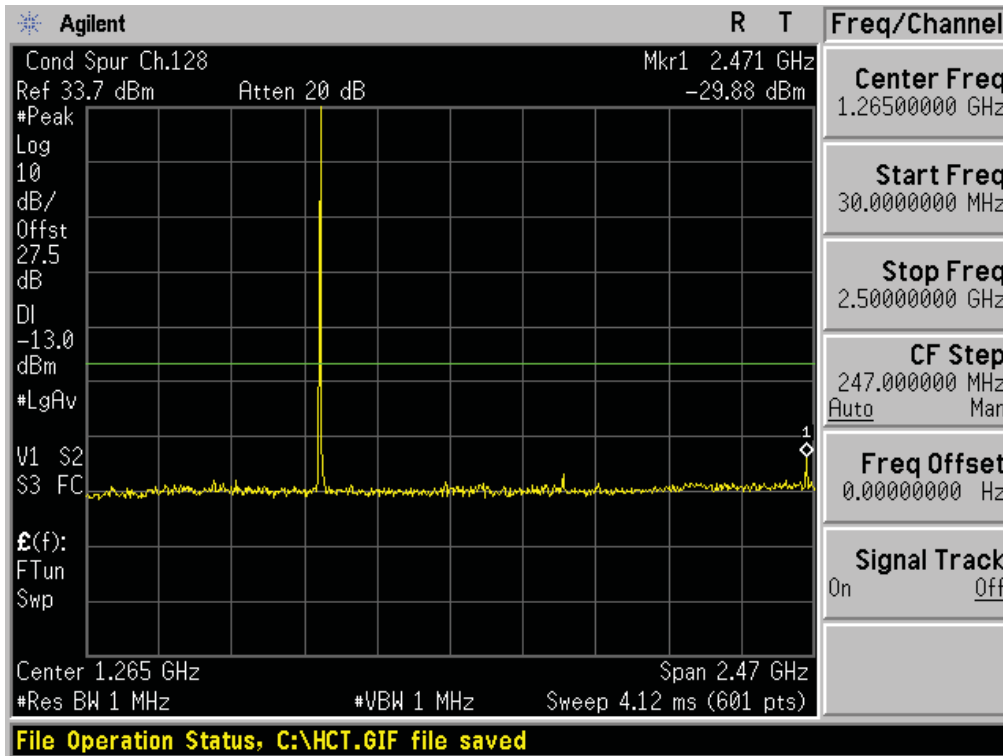

FCC CERTIFICATION REPORT			www.hct.co.kr
Test Report No. HCTR1210FR05-3	Date of Issue: November 14, 2012	EUT Type: CDMA/GSM/WCDMA/LTE Telematics	FCC ID: BEJLTC10N

■ GSM850 MODE (128 CH.) Conducted Spurious Emissions2

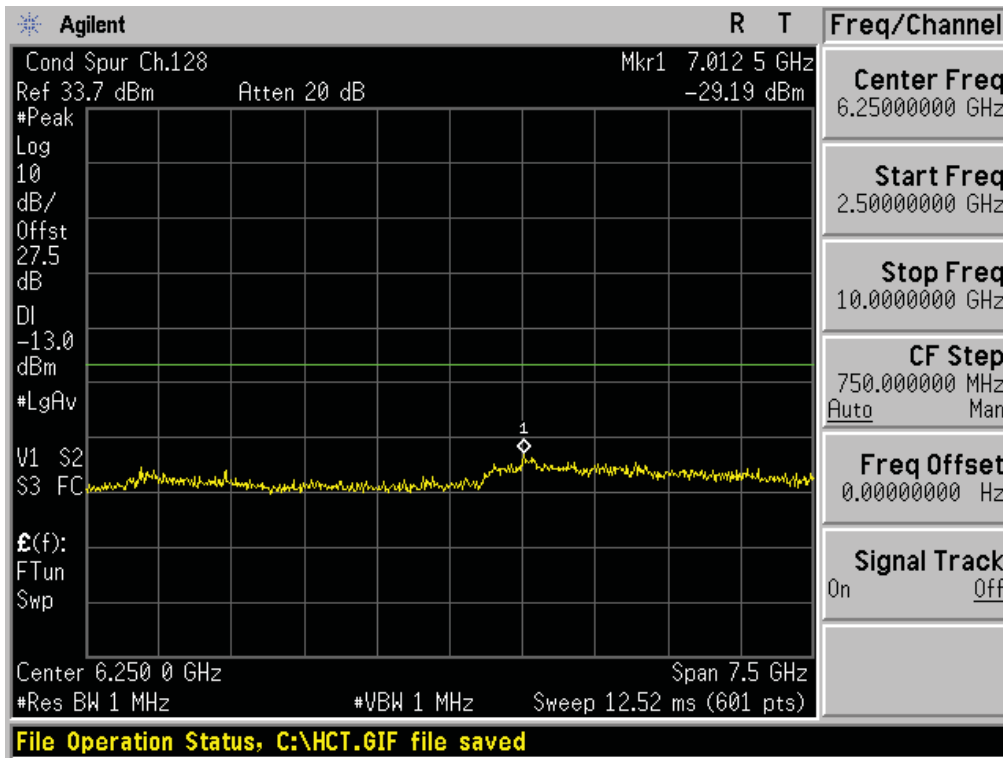

■ GSM850 MODE (190 CH.) Conducted Spurious Emissions1

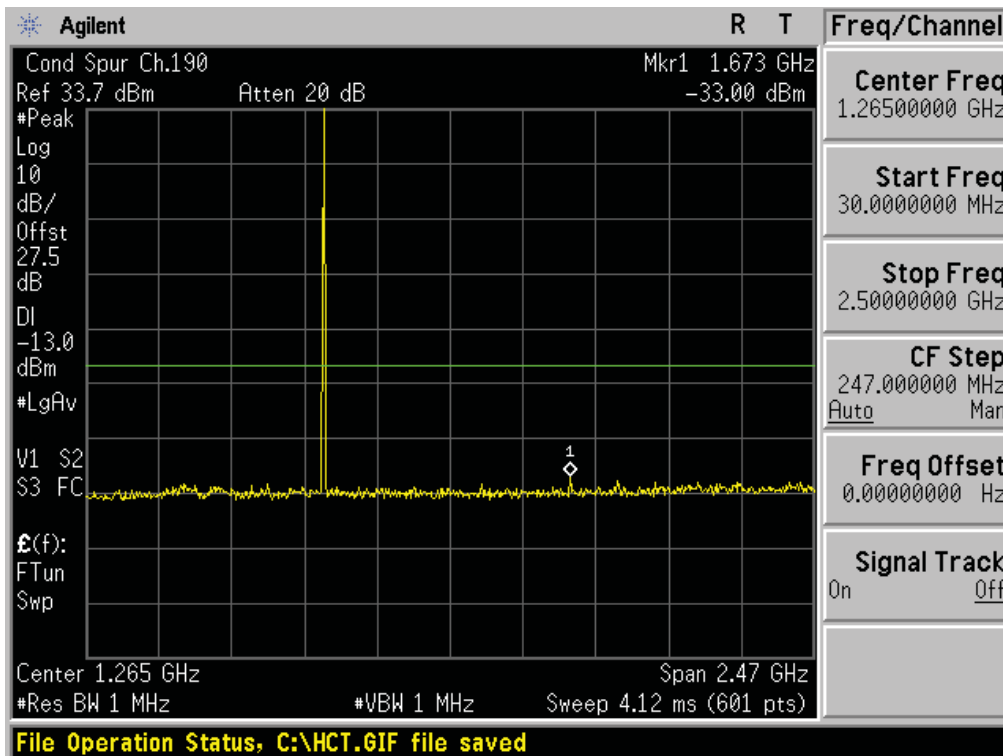

■ GSM850 MODE (190 CH.) Conducted Spurious Emissions2

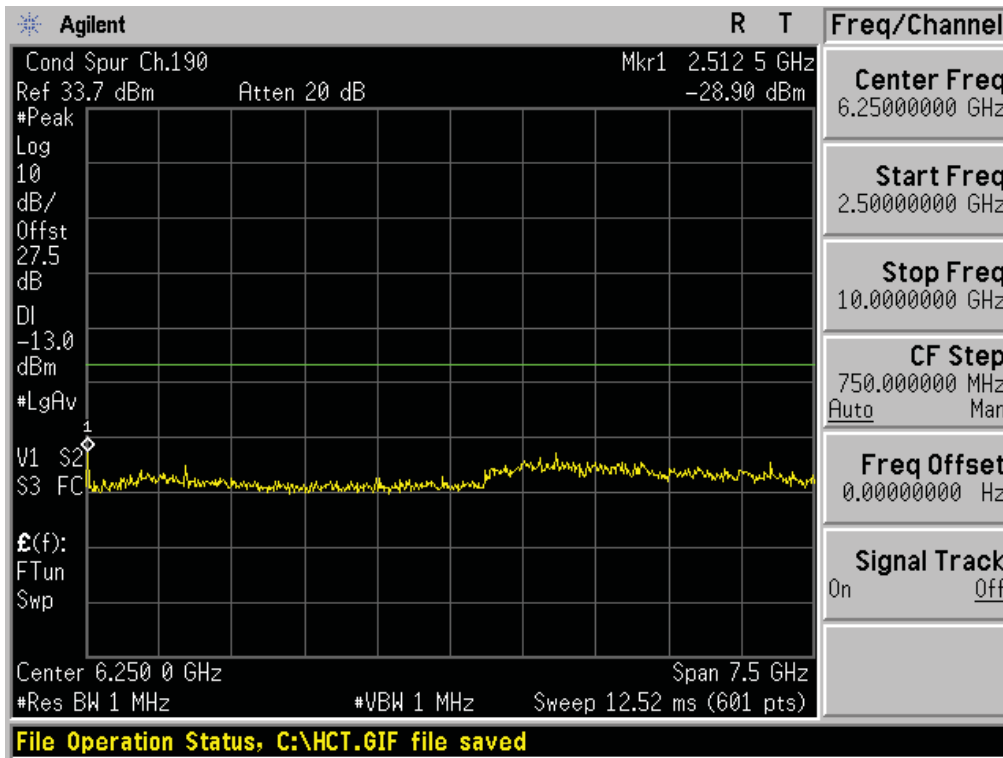

■ GSM850 MODE (251 CH.) Conducted Spurious Emissions1

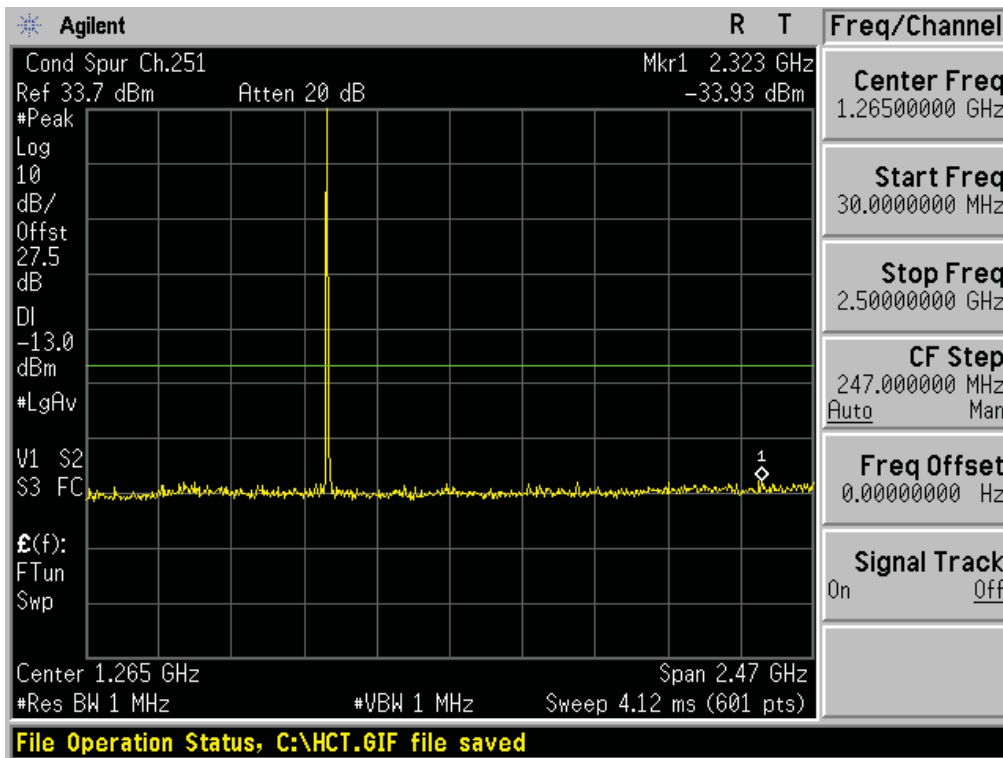

■ GSM850 MODE (251 CH.) Conducted Spurious Emissions2

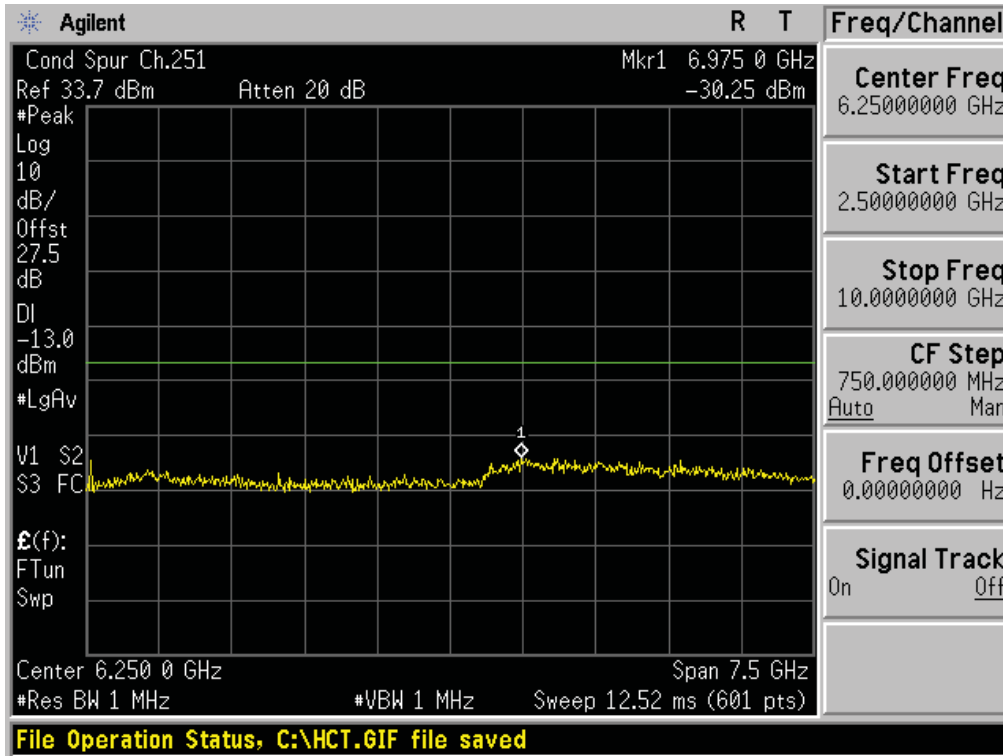

■ GSM1900 MODE (512 CH.) Conducted Spurious Emissions1

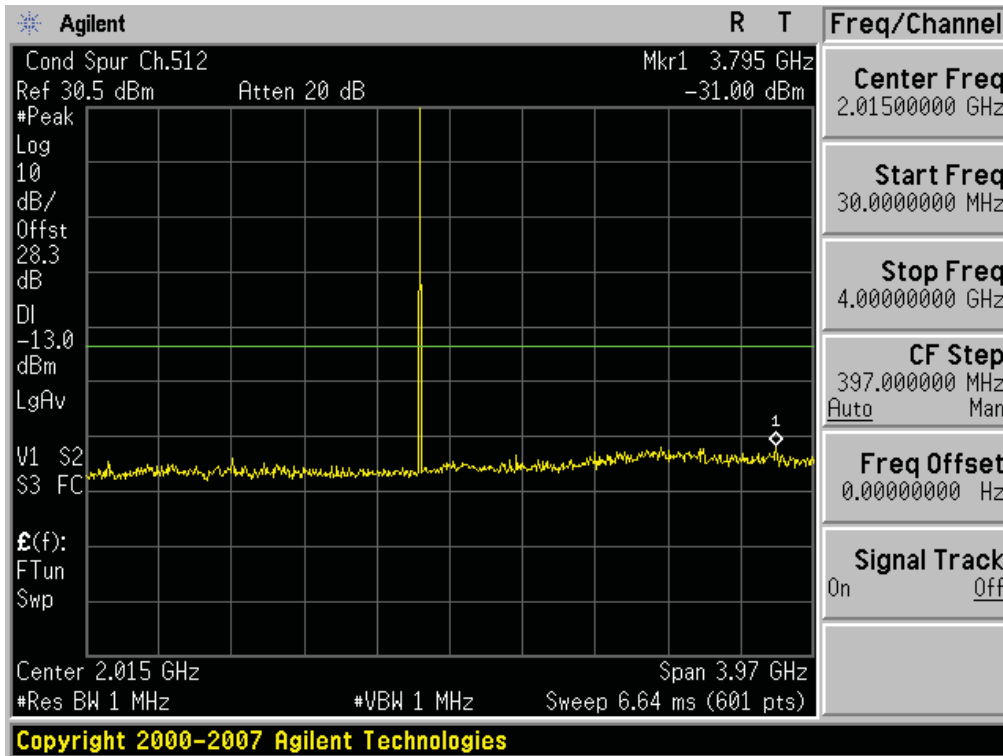

■ GSM1900 MODE (512 CH.) Conducted Spurious Emissions2

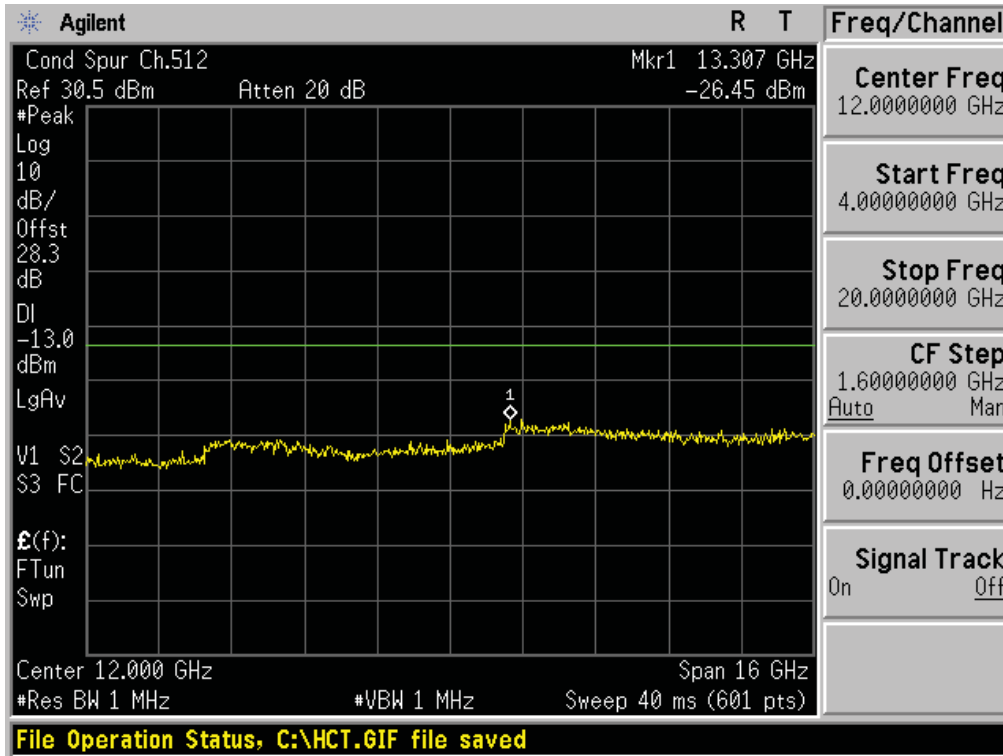

■ GSM1900 MODE (661 CH) Conducted Spurious Emissions1

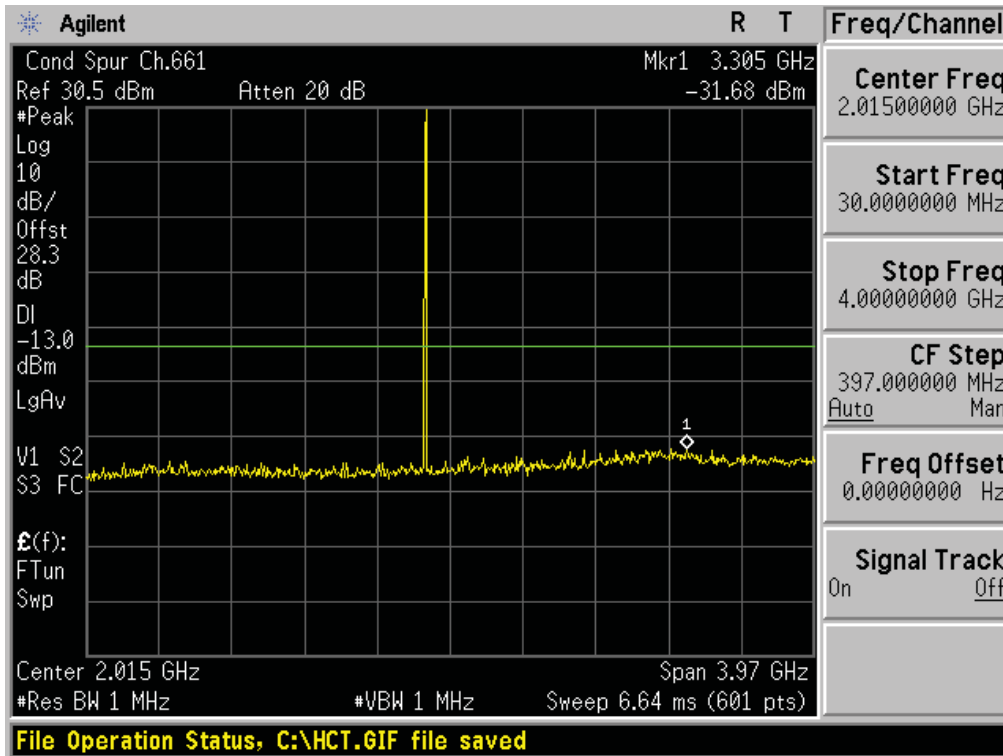

■ GSM1900 MODE (661 CH.) Conducted Spurious Emissions2

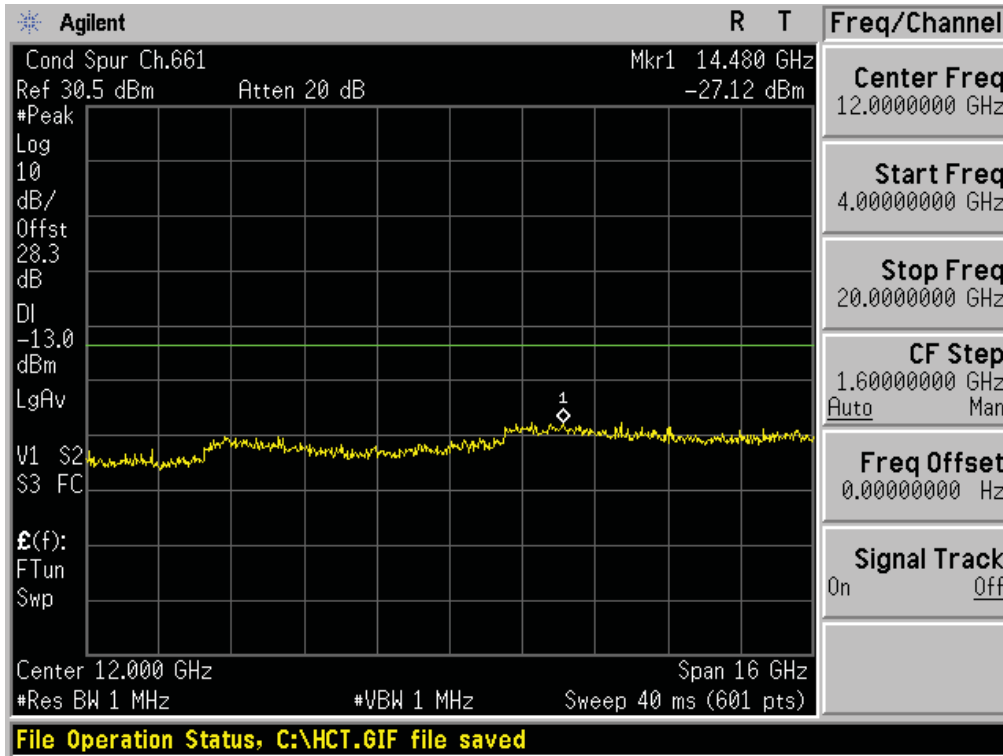

■ GSM1900 MODE (810 CH.) Conducted Spurious Emissions1

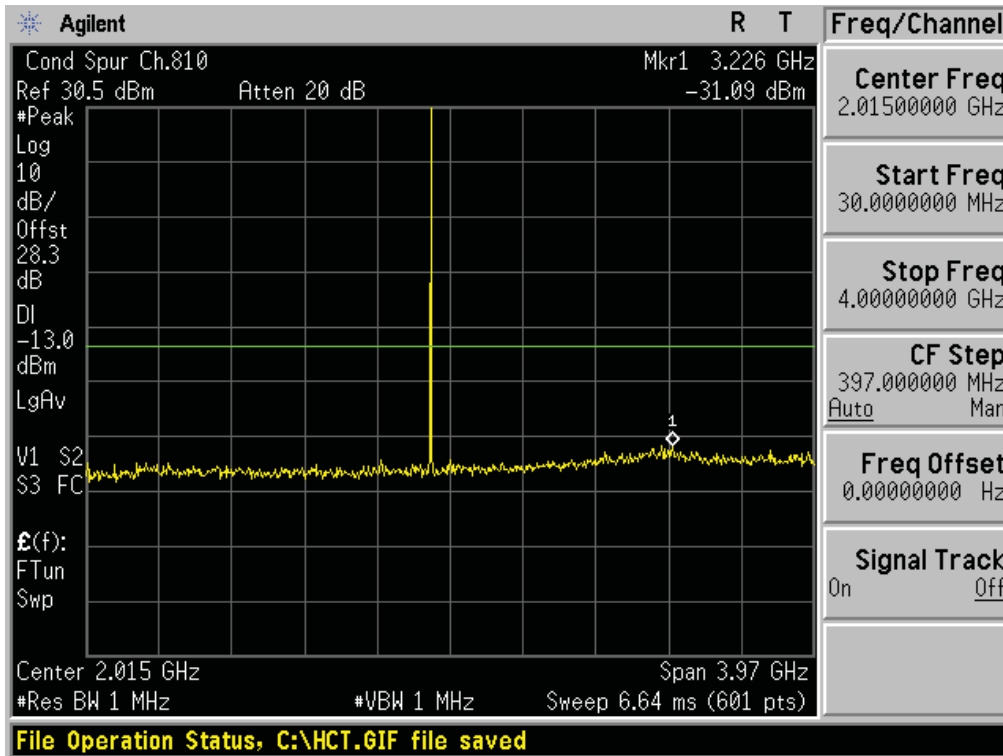

■ GSM1900 MODE (810 CH.) Conducted Spurious Emissions2

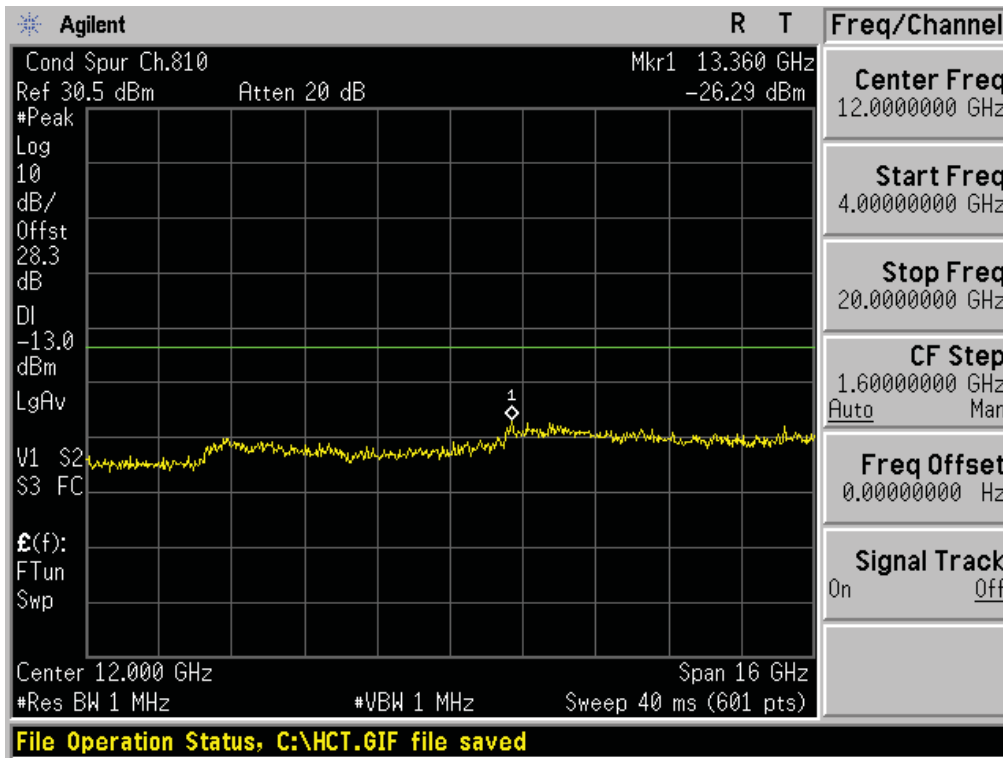

■ WCDMA850 MODE (4132 CH.) Conducted Spurious Emissions1

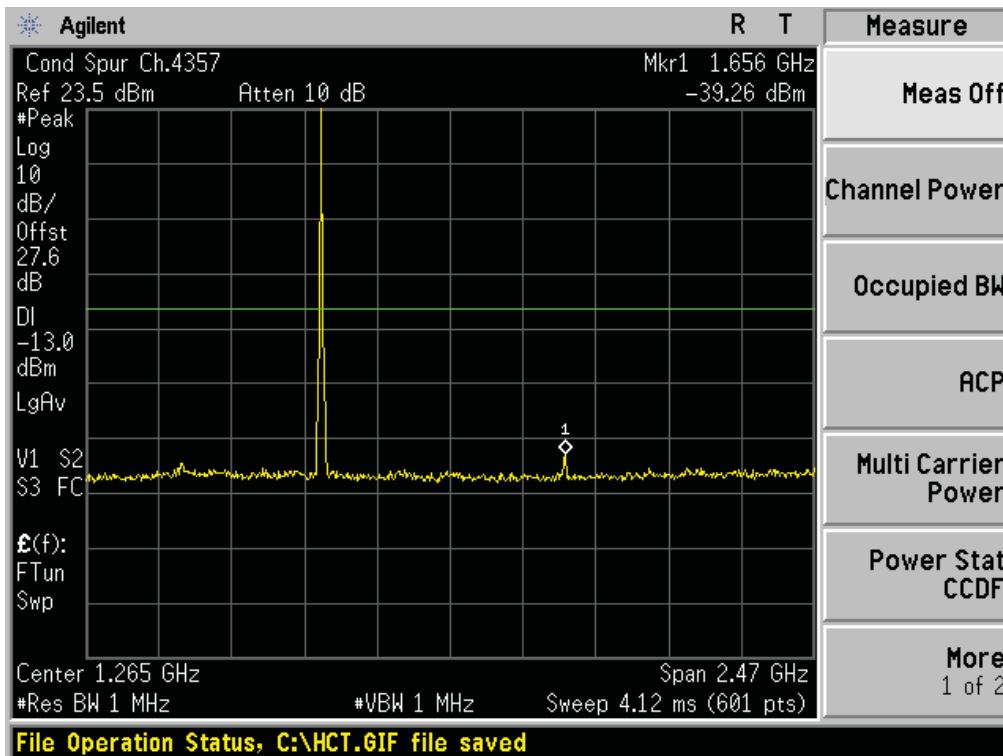

■ WCDMA850 MODE (4132 CH.) Conducted Spurious Emissions2

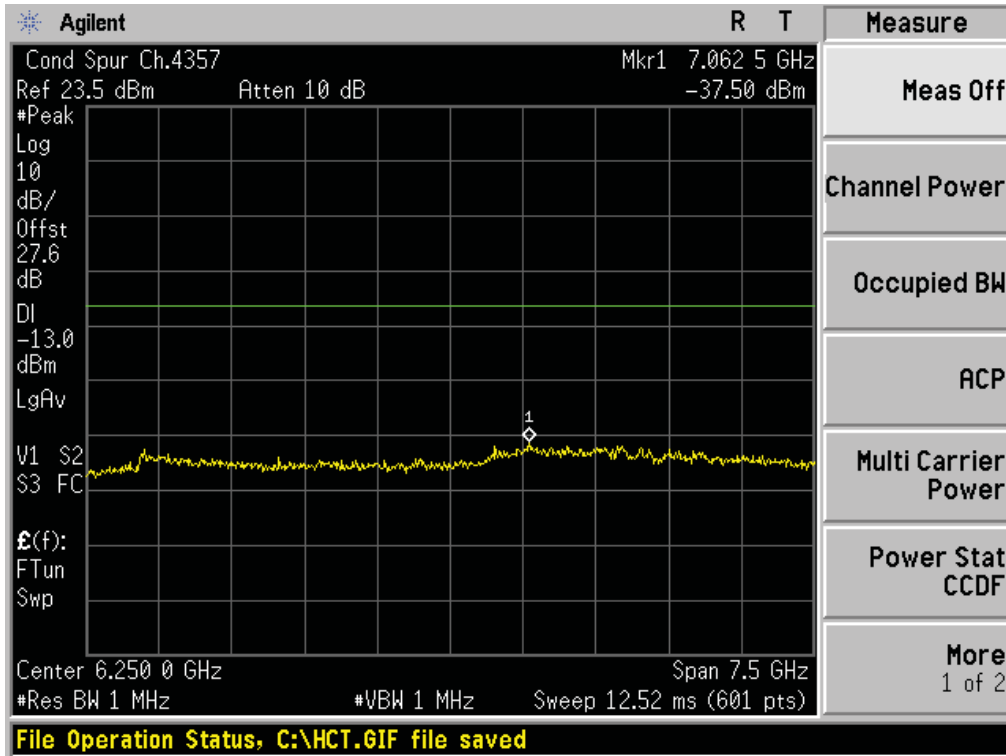

■ WCDMA850 MODE (4183 CH.) Conducted Spurious Emissions1

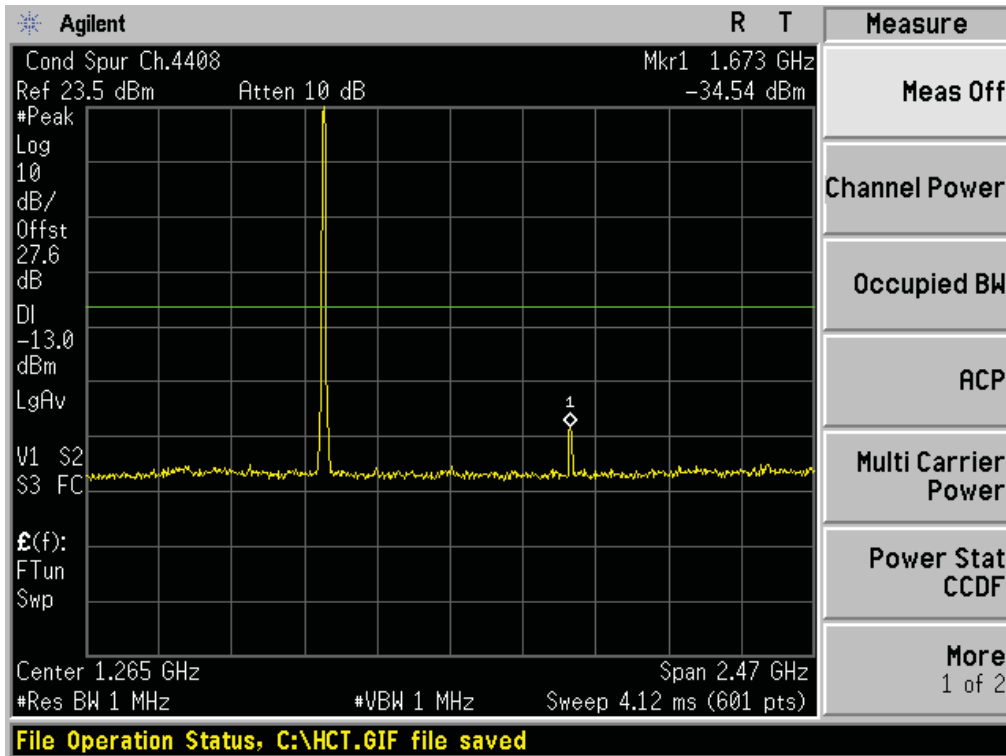

■ WCDMA850 MODE (4183 CH.) Conducted Spurious Emissions2

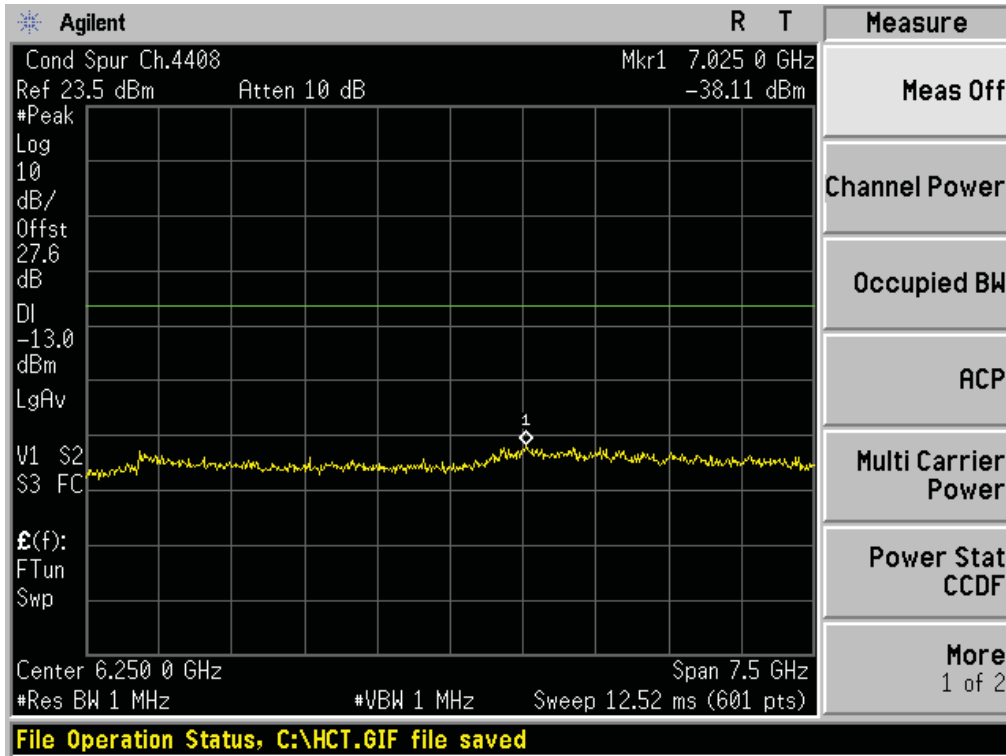

■ WCDMA850MODE (4233 CH.) Conducted Spurious Emissions1

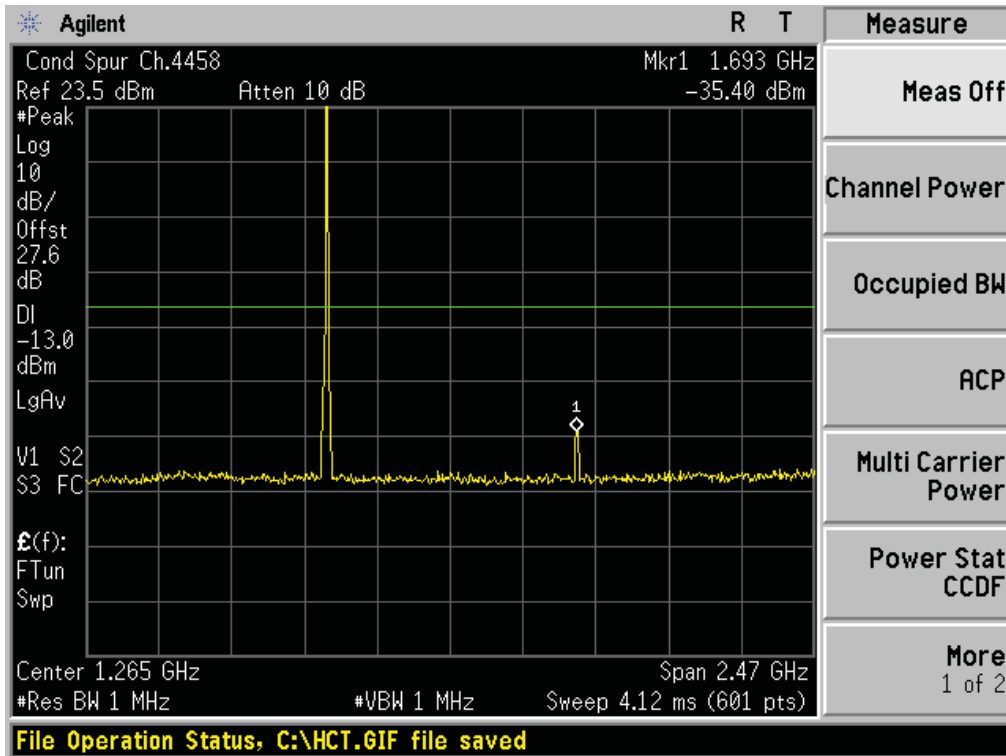

■ WCDMA850MODE (4233 CH.) Conducted Spurious Emissions2

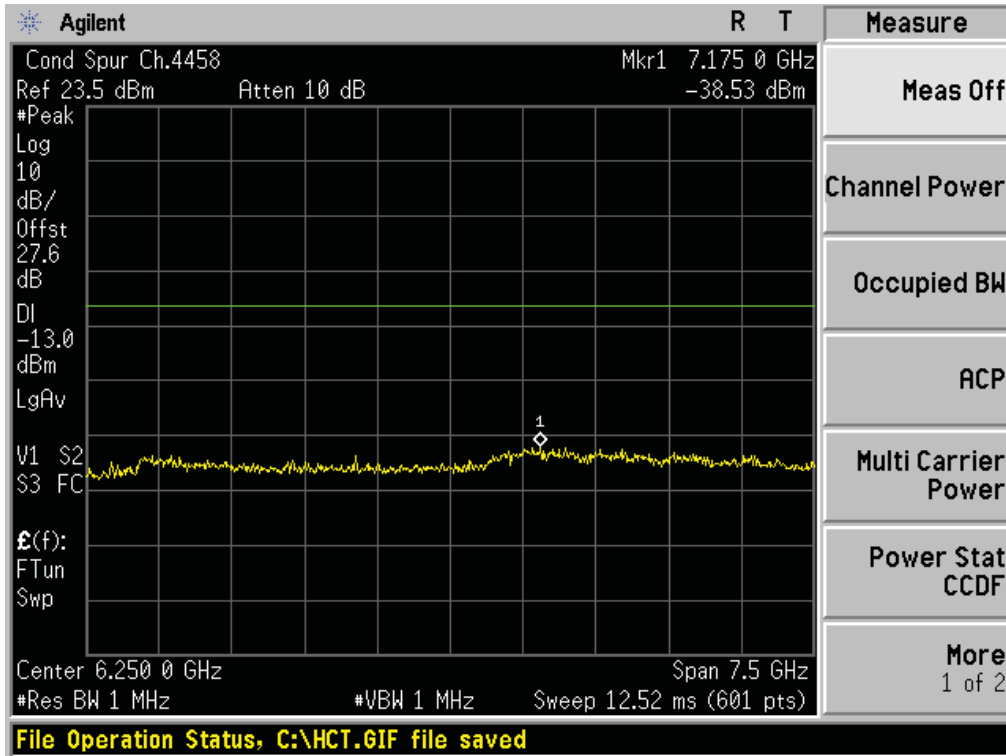

■ WCDMA1900 MODE (9262 CH.) Conducted Spurious Emissions1

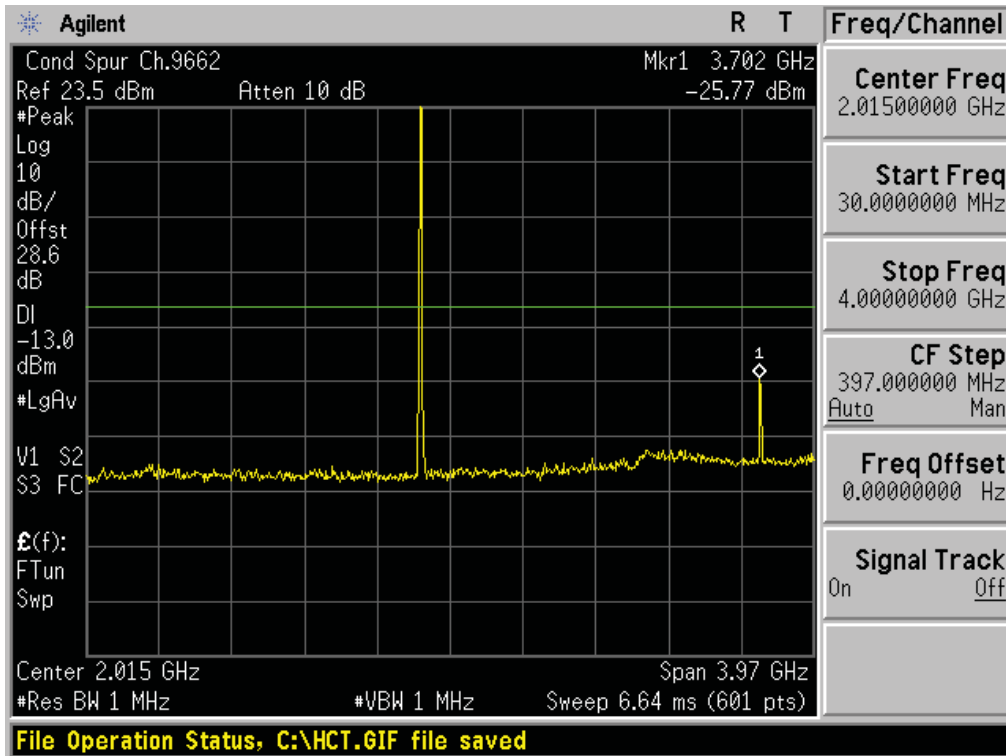

■ WCDMA1900 MODE (9262 CH.) Conducted Spurious Emissions2

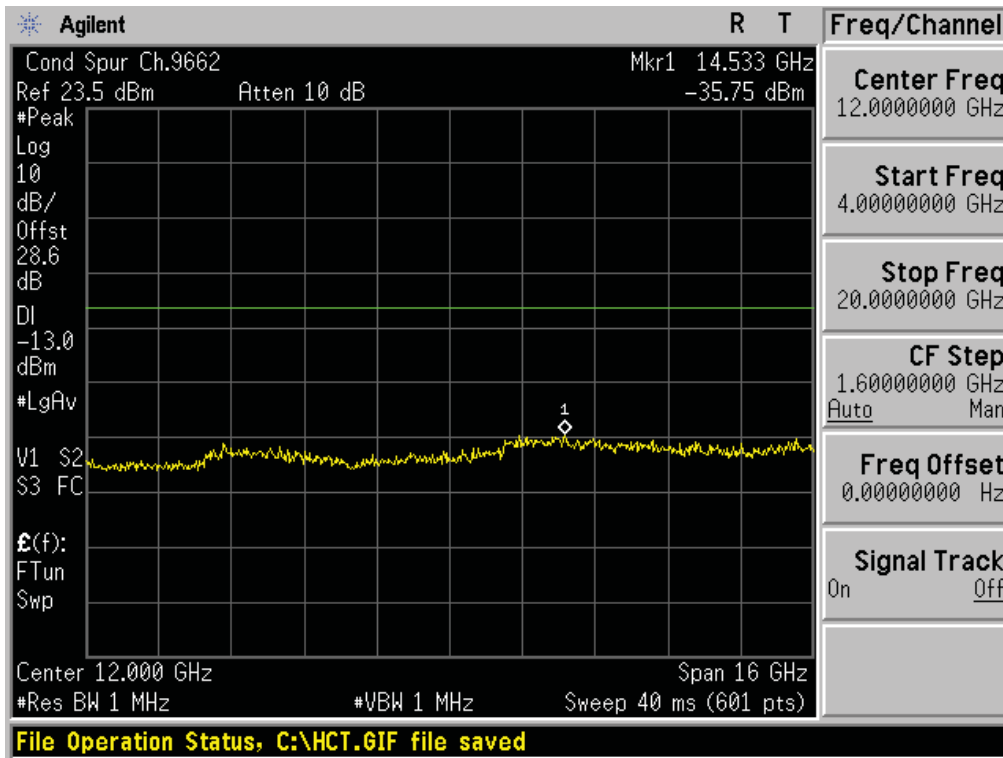

■ WCDMA1900 MODE (9400 CH.) Conducted Spurious Emissions1

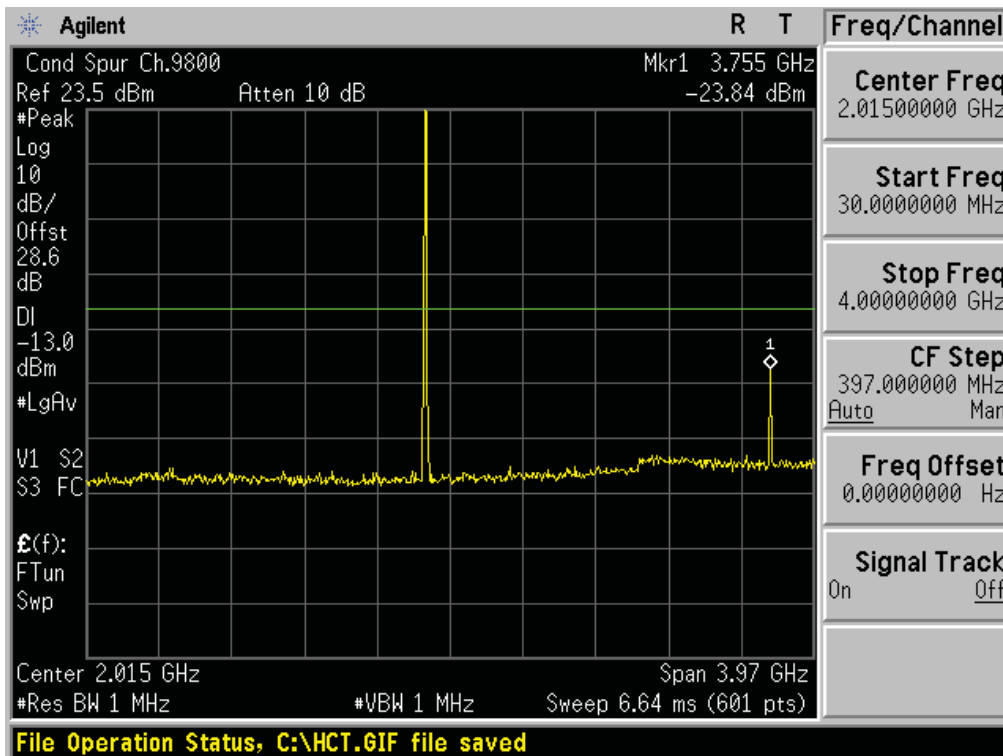

FCC CERTIFICATION REPORT

FCC CERTIFICATION REPORT			www.hct.co.kr
Test Report No. HCTR1210FR05-3	Date of Issue: November 14, 2012	EUT Type: CDMA/GSM/WCDMA/LTE Telematics	FCC ID: BEJLTC10N

■ WCDMA1900 MODE (9400 CH.) Conducted Spurious Emissions2

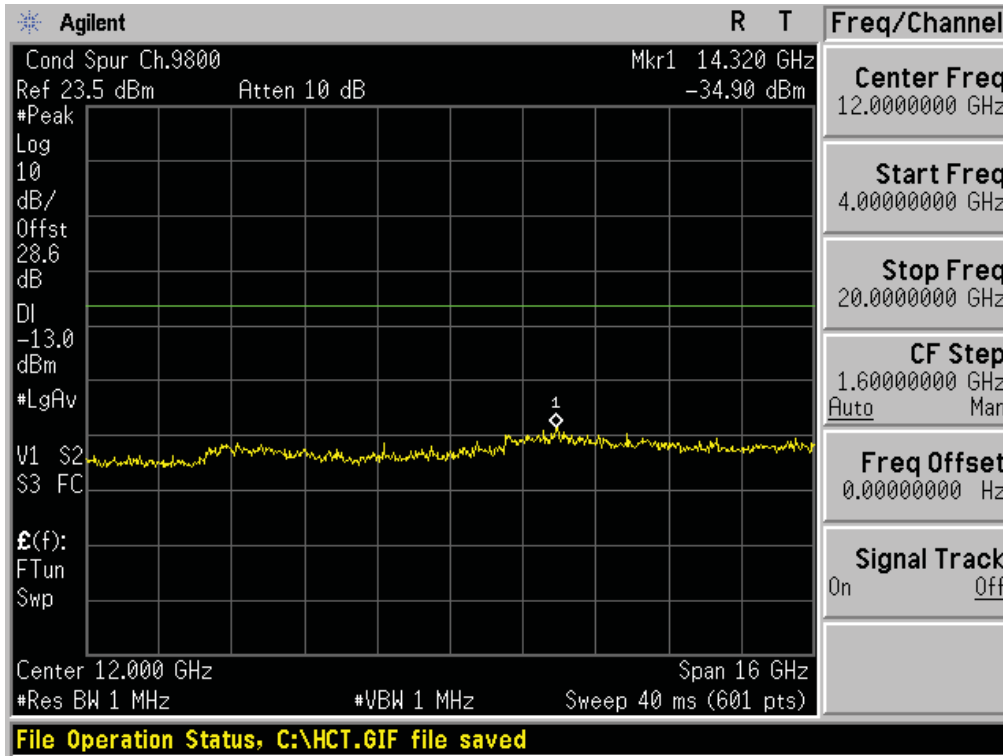

■ WCDMA1900 MODE (9538 CH.) Conducted Spurious Emissions1

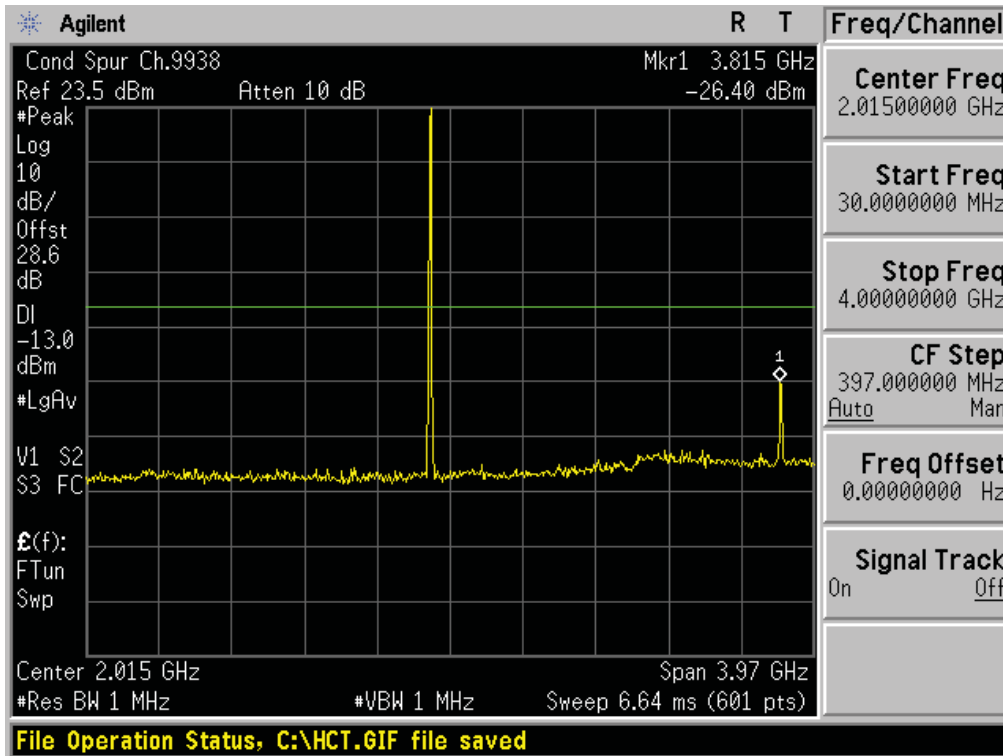

FCC CERTIFICATION REPORT

FCC CERTIFICATION REPORT			www.hct.co.kr
Test Report No. HCTR1210FR05-3	Date of Issue: November 14, 2012	EUT Type: CDMA/GSM/WCDMA/LTE Telematics	FCC ID: BEJLTC10N

■ WCDMA1900 MODE (9538 CH.) Conducted Spurious Emissions2

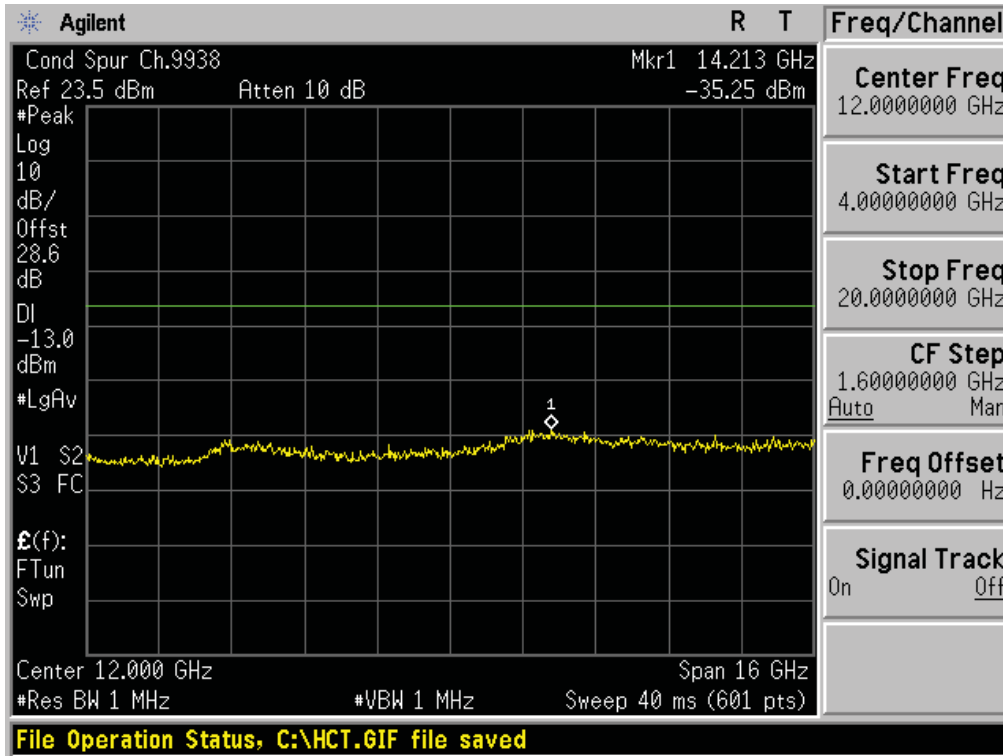

■ WCDMA1700 MODE (1312 CH.) Conducted Spurious Emissions1

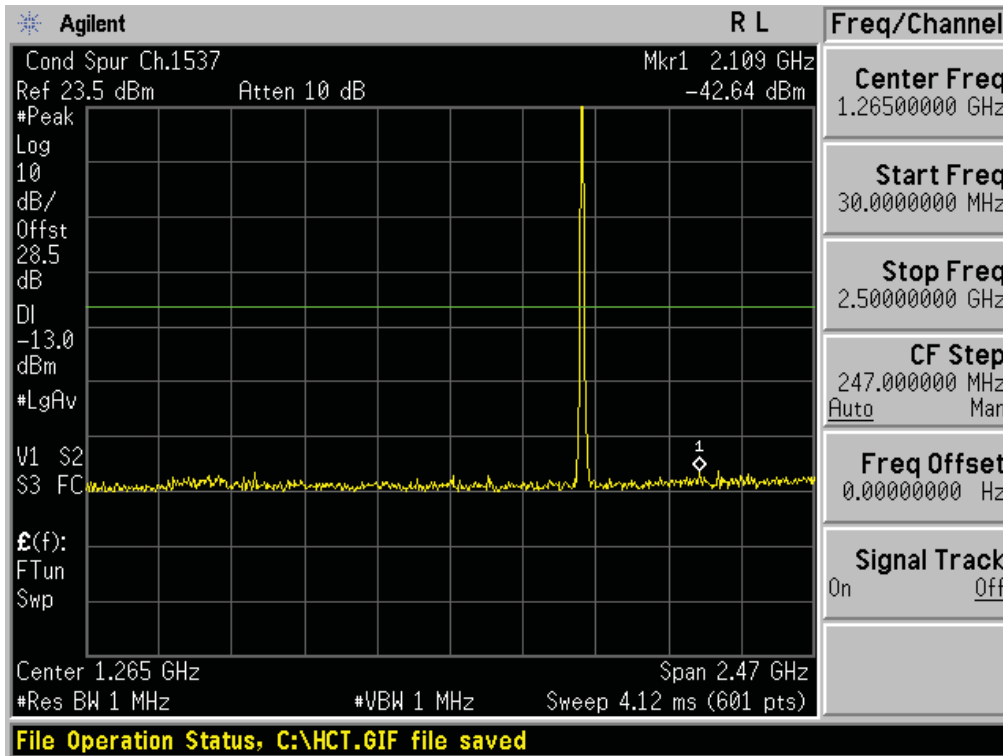

FCC CERTIFICATION REPORT

FCC CERTIFICATION REPORT			www.hct.co.kr
Test Report No. HCTR1210FR05-3	Date of Issue: November 14, 2012	EUT Type: CDMA/GSM/WCDMA/LTE Telematics	FCC ID: BEJLTC10N

■ WCDMA1700 MODE (1312 CH.) Conducted Spurious Emissions2

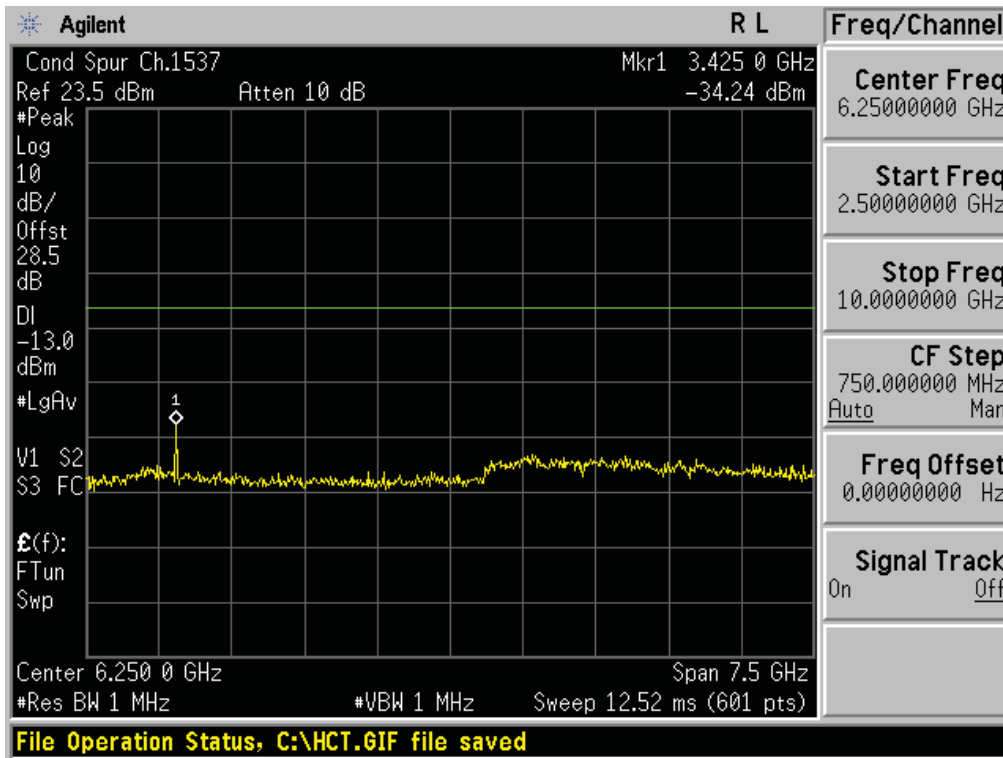

■ WCDMA1700 MODE (1412 CH.) Conducted Spurious Emissions1

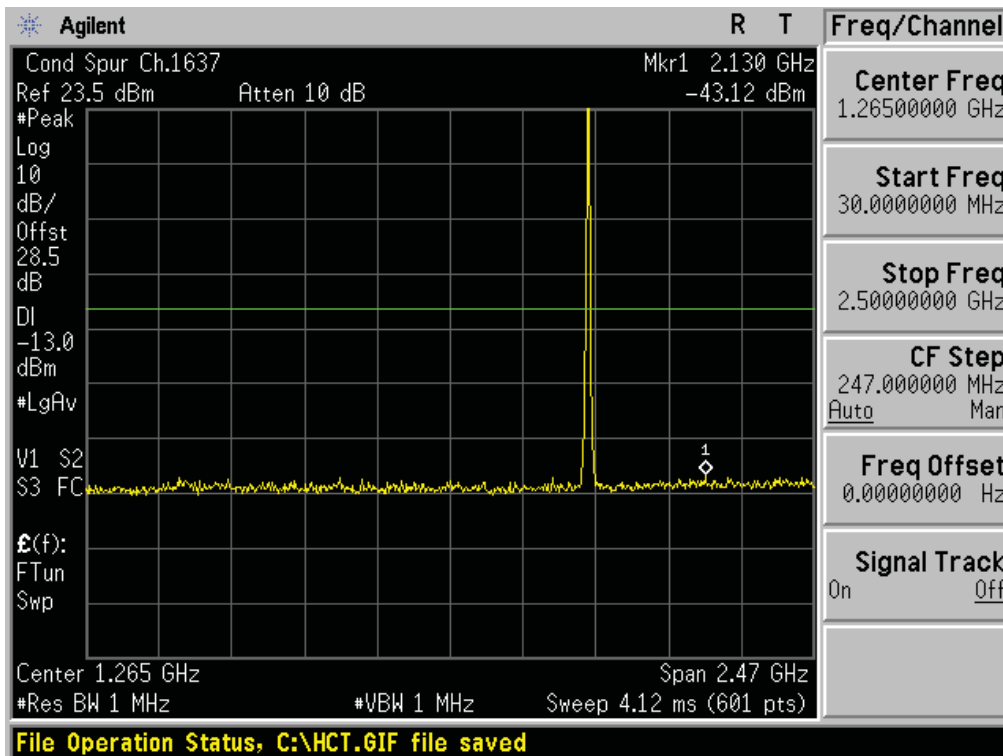

■ WCDMA1700 MODE (1412 CH.) Conducted Spurious Emissions2

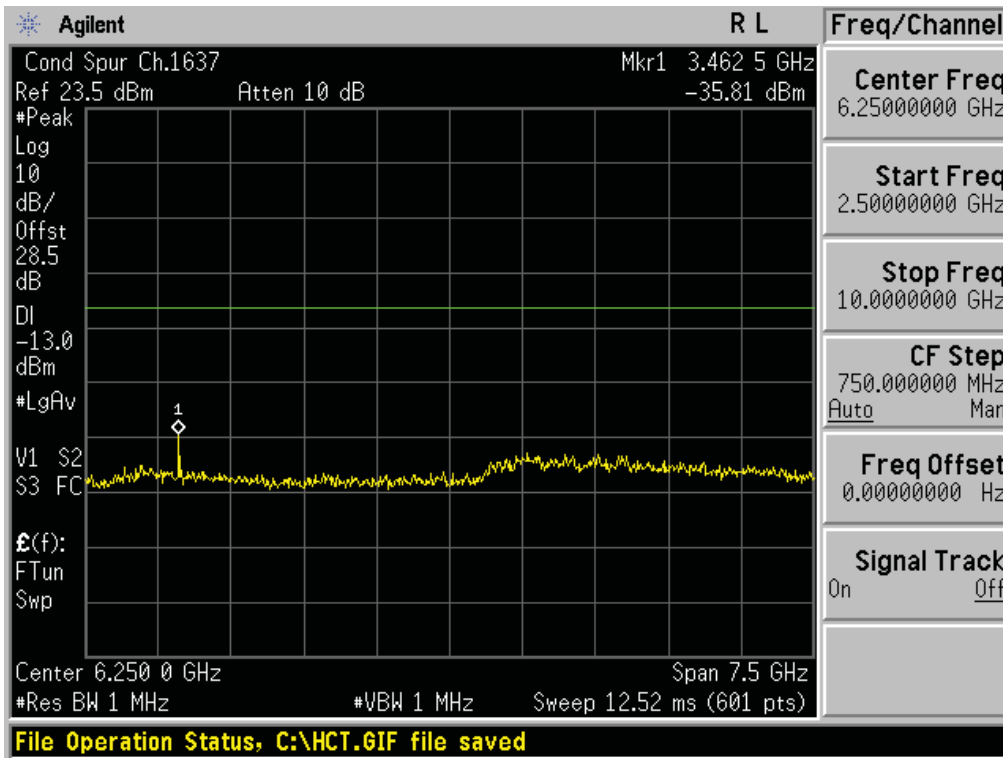

■ WCDMA1700 MODE (1513 CH.) Conducted Spurious Emissions1

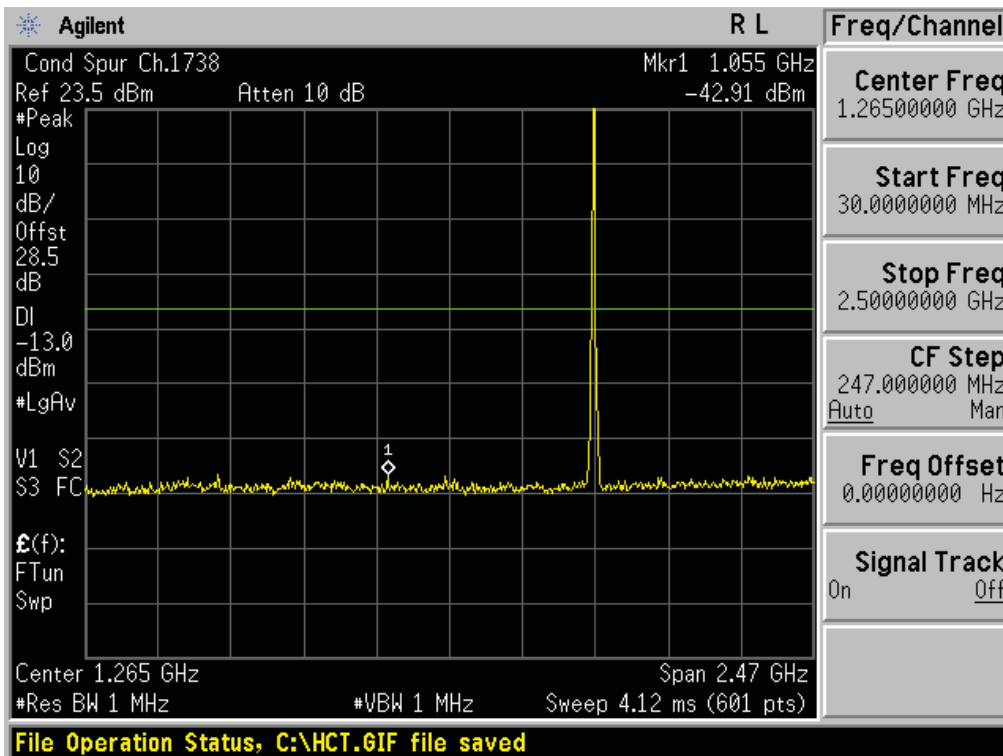

FCC CERTIFICATION REPORT

Test Report No. HCTR1210FR05-3	Date of Issue: November 14, 2012	EUT Type: CDMA/GSM/WCDMA/LTE Telematics	www.hct.co.kr FCC ID: BEJLTC10N
-----------------------------------	-------------------------------------	--	--

■ WCDMA1700 MODE (1513 CH.) Conducted Spurious Emissions2

