



Underwriters Laboratories Inc.

[www.ul.com/emc](http://www.ul.com/emc)  
[www.ulk.co.kr](http://www.ulk.co.kr)

Order No.: 10468098  
Report No.: 14-10468098-5-FCC  
Date: August 21, 2014  
Model No.: LND1420IWLM  
FCC ID.: BEJ- LND1420IWLM

## **FCC Maximum Permissible Exposure Report**

**in accordance with  
FCC Part 1 Subpart I §1.1307(b) & §1.1310**

**for**

### **Car AVN with Bluetooth**

**LG Electronics Inc.**

**222, LG-ro Jinwi-myeon, Pyeongtaek-si, Gyeonggi-do, 451-713, Republic of Korea  
Copyright © 2005 Underwriters Laboratories Inc.**

Underwriters Laboratories Inc. authorizes the above-named company to reproduce this Report provided it is reproduced in its entirety.

Only those products bearing the UL Mark should be considered as being covered by UL.

**Summary of Test Results:**

The following tests were performed on a sample submitted for evaluation of compliance with FCC Part 1 Subpart I Section 1.1307(b) & 1.1310

No	Reference Clause No.	Conformance Requirements	Result	Verdict	Remark
1	1.1307(b)(1) 1.1310	Maximum Permissible Exposure (Exposure of Humans to RF Fields)	Complied		

**Conclusion:**

The tests listed in the Summary of Testing section of this report have been performed and the results recorded by UL Korea Ltd. in accordance with the procedures stated in each test requirement and specification. The test list was determined by the Applicant as being applicable to the Equipment Under Test. As a result, the subject product has been verified to comply or not comply as noted in the Summary of Testing with each test specification. The test results relate only to the items tested.



Witness tested by  
Changmin, Kim WiSE Engineer  
UL Verification Services- 3014ASEO  
UL Korea Ltd.  
Aug. 21, 2014

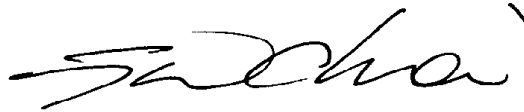

Reviewed by  
Jeawoon, Choi, WiSE Operations Manager  
UL Verification Services- 3014ASEO  
UL Korea Ltd.  
Aug. 21, 2014

**Test Report Details**

Tests Performed By: UL Korea Ltd.  
26<sup>th</sup> FL. GFC Center, 737 Yeoksam-dong, Gangnam-gu, Seoul, 135-984, Korea

Test Site: EMC compliance Ltd.  
65, Sinwon-ro, Yeongtong-gu, Suwon- si, Gyeonggi-do, 443-390, Korea

Applicant: LG Electronics Inc.  
222, LG-ro Jinwi-myeon, Pyeongtaek-si, Gyeonggi-do, 451-713, Republic of Korea

Applicant Contact: Yongduck Kwon  
Title: Research Engineer  
Phone: +82-31-610-9612  
E-mail: [yongduk.kwon@lge.com](mailto:yongduk.kwon@lge.com)

Product Type: CAR AVN with Bluetooth

Model Number: LND1420IWLM

Trademark 

Sample Serial Number: N/A

Test standards: FCC Part 15 C Section 15.247  
Operation within the bands 902–928 MHz, 2400–2483.5 MHz,  
and 5725–5850 MHz

Sample Serial Number: N/A

Sample Receive Date: July 21, 2014

Testing Start Date: July 21, 2014

Testing Complete Date: July 31, 2014

**Overall Results: Pass**

UL Korea Ltd. reports apply only to the specific test samples and test results submitted for UL's review. All samples tested were in good operating condition throughout the entire test program. It is the manufacturer's responsibility to assure that additional production units of this model are manufactured with identical electrical and mechanical components. UL Korea Ltd. shall have no liability for any deductions, inferences or generalizations drawn by the client or others from UL Korea Ltd. issued reports. This report shall not be used to claim, constitute or imply product certification, approval, or any agency of the National Authorities. This report may contain test results that are not covered by the NVLAP or KOLAS accreditation.

## Report Directory

<b>1. GENERAL PRODUCT INFORMATION .....</b>	<b>5</b>
1.1. EQUIPMENT DESCRIPTION: .....	5
1.2. DETAILS OF TEST EQUIPMENT (EUT):..... 오류! 책갈피가 정의되어 있지 않습니다.	
1.3. EQUIPMENT CONFIGURATION:..... 오류! 책갈피가 정의되어 있지 않습니다.	
1.4. TECHNICAL DATA: .....	6
1.5. ANTENNA INFORMATION: .....	7
1.6. EQUIPMENT TYPE: .....	7
1.7. TECHNICAL DESCRIPTION AND DOCUMENTS: .....	7
1.8. DESCRIPTION OF ADDITIONAL MODEL NAME.....	8
<b>2. TEST SPECIFICATION .....</b>	<b>9</b>
<b>3. TEST CONDITIONS .....</b>	<b>10</b>
3.1. EQUIPMENT USED DURING TEST .....	오류! 책갈피가 정의되어 있지 않습니다.
3.2. INPUT/OUTPUT PORTS .....	오류! 책갈피가 정의되어 있지 않습니다.
3.3. POWER INTERFACE .....	오류! 책갈피가 정의되어 있지 않습니다.
3.4. OPERATING FREQUENCIES .....	11
3.5. OPERATION MODES .....	12
3.6. ENVIRONMENT CONDITIONS.....	12
3.7. TEST CONFIGURATIONS .....	12
3.8. LIST OF TEST EQUIPMENT.....	12
<b>4. TEST RESULTS OF RF EXPOSURE EVALUATION .....</b>	<b>13</b>
4.1. OUTPUT POWER INTO ANTENNA & RF EXPOSURE EVALUATION DISTANCE FOR FCC .....	15

## 1. General Product Information

### 1.1. Equipment Description:

15.247(g): In accordance with the Bluetooth Industry Standard, the system is designed to comply with all of the regulations in Section 15.247 when the transmitter is presented with a continuous data (or information) system.

15.247(h): In accordance with the Bluetooth Industry Standard, the system does not coordinate its channels selection/hopping sequence with other frequency hopping systems for the express purpose of avoiding the simultaneous occupancy of individual hopping frequencies by multiple transmitters.

### 1.2. Details of Test Equipment (EUT)

- Equipment Type : CAR AVN with Bluetooth
- Model No. : LND1420IWLM
- Trade name : LG
- Type of test Equipment : Portable type
- Operating characteristic : Short range wireless device operating in the 2400 – 2483.5 ISM frequency band
- Manufacturer : LG Electronics Inc.  
222, LG-ro Jinwi-myeon, Pyeongtaek-si, Gyeonggi-do, 451-713, Republic of Korea

### 1.3. Equipment Configuration

The EUT is consisted of the following component provided by the manufacturer.

Use*	Product Type	Manufacturer	Model	Comments
EUT	CAR AVN with Bluetooth		LND1420IWLM	-
<b>Note:</b> Use = EUT - Equipment Under Test, AE - Auxiliary/Associated Equipment. SIM - Simulator (Not Subjected to Test)				

#### 1.4. Technical Data:

Transmitter frequency range(s)	2,402~2,480 MHz
Number of Channel	79 channels
Receiver frequency range(s)	2,402~2,480 MHz
Transmitter power	-3.16 dBm (Max 2.5 dBm)
Modulation	FHSS (GFSK, $\pi/4$ DQPSK, 8DPSK)
Power supply	Typ. 12Vdc

Note ;

1. All the technical data described above were provided by the manufacturer.

### 1.5. Antenna Information:

Antenna Model Name : ALA621C4  
Antenna Type : Chip Antenna  
Manufacturer : AMOTECH  
Transmit Gain : Max. 0.7 dBi  
Azimuth Beam Pattern : Linear

### 1.6. Equipment Type:

- Radio and ancillary equipment for fixed or semi-fixed use  
 Radio and ancillary equipment for vehicular mounted use  
 Radio and ancillary equipment for portable or handheld use
- Stand alone     Host connected     Host connected
- Self contained single unit     Module with associated connection or interface

### 1.7. Technical description and documents:

No.	Document Title and Description
1	User Manual

Note: The following documents were provided by the manufacturer.

**1.8. Description of additional model name**

-	Model	Description	Comment
1	LND1420IWLM	Basic model	-
<b>*Note:</b> The manufacturer has declared to all the multiple model names into the basic model without any further evaluation by UL.			

## 2. Test Specification

The following test specifications and standards have been applied and used for testing.

KDB 447498 D01 : Mobile and Portable Device RF Exposure Procedures and Equipment Authorization Policies

### 3. Test Conditions

#### 3.1. Equipment Used During Test

Use*	Product Type	Manufacturer	Model	Comments
EUT	CAR AVN with Bluetooth		LND1420IWLM	-
SIM	Bluetooth Tester	Tescom	TC-3000A	-

**Note:** Use = EUT - Equipment Under Test, AE - Auxiliary/Associated Equipment. SIM - Simulator (Not Subjected to Test)

#### 3.2. Input/Output Ports

Port #	Name	Type*	Cable Max. >3m	Cable Shielded	Comments
1	DC input port	DC	1.0	Unshielded	Car AVN with Bluetooth
2	ANT IN	I/O	20.0	Shielded	
3	GPS	I/O	1.5	Shielded	
4	Jack Accessory	I/O	1.0	Unshielded	
5	C Connector	I/O	0.4	Unshielded	
6	A Connector	I/O	0.4	Unshielded	
7	AUX IN	I/O	0.8	Unshielded	Jack Accessory
8	USB	I/O	-	-	

**Note:**  
 \* AC = AC Power Port      DC = DC Power Port      N/E = Non-Electrical  
 I/O = Signal Input or Output Port (Not Involved in Process Control)  
 TP = Telecommunication Ports

#### 3.3. Power Interface

Mode #	Voltage (V)	Current (A)	Power (W)	Frequency (DC/AC-Hz)	Phases (#)	Comments
1	12 V DC	-	-	DC	-	Normal operating voltage

### 3.4. Operating Frequencies

Mode #	Frequency tested
1	- Low : 2402 MHz / CH = 1 - Mid : 2441 MHz / CH = 39 - Top : 2480 MHz / CH= 78

### 3.5. Operation Modes

Mode #	Description
1	Carrier on mode: Signal from the RF module was generated continuously for the representative channels (Low, Mid, High) by the test program incorporated

### 3.6. Environment Conditions

Parameters	Normal condition
Temperature	+ 15°C ~ +35°C
Humidity	20% ~ 75%
Supply voltage	AC 120 V (Rated nominal voltage)

Note ;  
 - The operating condition for humidity requirement has not been declared in the manufacturer's specification.  
 - Test has been carried out for three frequencies specified above under the normal condition.

### 3.7. Test Configurations

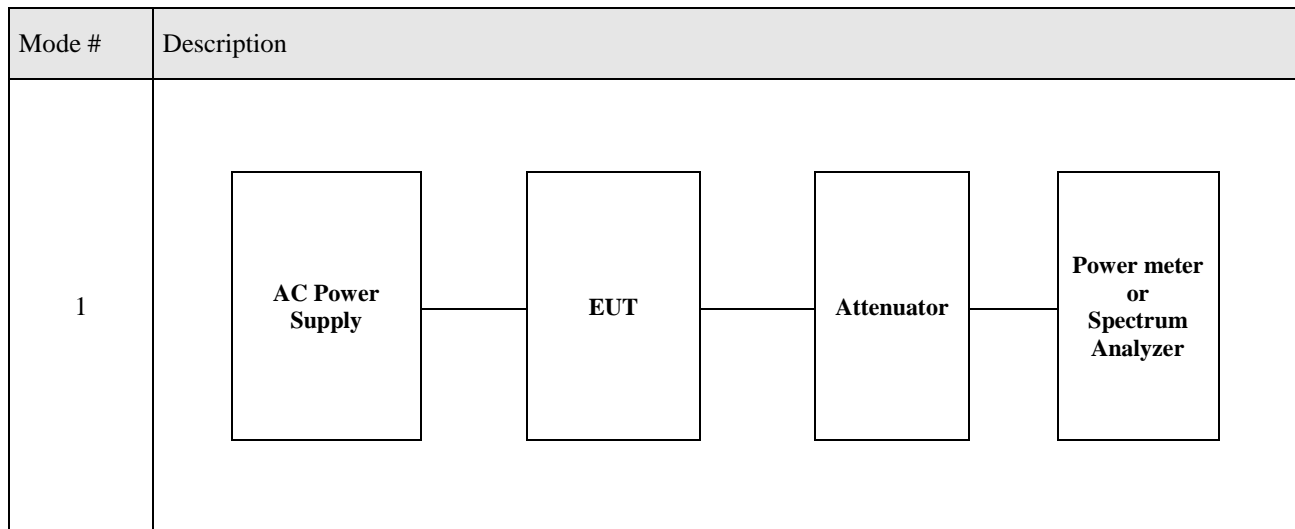

### 3.8. List of Test Equipment

No	Description	Manufacturer	Model	Identifier	Cal. Due
1	Spectrum Analyzer	R&S	FSV30	100914	15.08.05

#### 4. Test Results of RF Exposure Evaluation

TEST: RF Exposure Evaluation		
Method	<p>RF Exposure Evaluation of the EUT were measured according to the dictates in KDB 447498</p> <p>Pd the limit of MPE, 1 mW/cm<sup>2</sup>. If we know the maximum gain of the antenna and the total power input to the antenna, through the calculation, we will know the distance where the MPE limit is reached.</p> <p><b>Friis transmission formula: <math>P_d = (P_{out} * G) / (4 * \pi * R^2)</math></b></p> <p>Where Pd = power density in mW/cm<sup>2</sup>            Pout = output power to antenna in mW            G = gain of antenna in linear scale            Pi = 3.1416            R = distance between observation point and center of the radiator in cm</p> <p><b>General SAR test exclusion guidance</b></p> <p>The 1-g and 10-g SAR test exclusion thresholds for 100 MHz to 6 GHz at <i>test separation distances</i> ≤ 50 mm are determined by:  <math>[(max. power of channel, including tune-up tolerance, mW) / (min. test separation distance, mm)] * [\sqrt{f_{(GHz)}}] \leq 3.0</math> for 1-g SAR and <math>\leq 7.5</math> for 10-g extremity SAR, where  <math>f_{(GHz)}</math> is the RF channel transmit frequency in GHz</p> <p>Power and distance are rounded to the nearest mW and mm before calculation<sup>17</sup></p> <p>The result is rounded to one decimal place for comparison</p> <p>When the minimum <i>test separation distance</i> is &lt; 5 mm, a distance of 5 mm is applied to determine SAR test exclusion.</p>	
Reference Clause	Part1 I Section 1.1307(b) & 1.1310	
Parameters recorded during the test	Laboratory Ambient Temperature	27 °C
	Relative Humidity	53 %
	Frequency range	Measurement Point
Fully configured sample scanned over the following frequency range	2405 MHz - 2475 MHz	Antenna port

#### Configuration Settings

Power Interface Mode # (See Section 3.3)	EUT Operation Mode # (See Section 3.5)	Test Configurations Mode # (See Section 3.7)
1	1	1
Supplementary information: None		

**Limits**

**Environmental evaluation and exposure limit according to FCC Part 1, Subpart I, Section 1.1307(b) & 1.1310**

According to Section 1.1310, The criteria listed in the following table shall be used to evaluate the environment impact of human exposure to radio frequency (RF) radiation as specified in §1.1307(b)

Frequency Range (MHz)	Electric Field Strength(V/m)	Magnetic Field Strength (A/m)	Power Density (mW/cm <sup>2</sup> )	Average Time
(A) Limits for Occupational /Control Exposures				
300 – 1 500	--	--	F/300	6
1 500 – 100 000	--	--	5	6
(B) Limits for General Population/Uncontrol Exposures				
300 – 1 500	--	--	F/1500	6
<b><u>1 500 – 100 000</u></b>	<b><u>--</u></b>	<b><u>--</u></b>	<b><u>1</u></b>	<b><u>30</u></b>

**Environmental evaluation and exposure limit according to RSS-102**

RF Field Strength Limits for Devices Used by the General Public (Uncontrolled Environment)

Frequency Range (MHz)	Electric Field (V/m rms)	Magnetic Field (A/m rms)	Power Density (W/m <sup>2</sup> )	Averaging Time (minutes)
0.003-1	280	2.19	-	6
1-10	280/ <i>f</i>	2.19/ <i>f</i>	-	6
10-30	28	2.19/ <i>f</i>	-	6
30-300	28	0.073	2*	6
300-1500	1.585 <i>f</i> <sup>0.5</sup>	0.0042 <i>f</i> <sup>0.5</sup>	<i>f</i> /150	6
1500-15000	61.4	0.163	10	6
15000-150000	61.4	0.163	10	616000/ <i>f</i> <sup>1.2</sup>
150000-300000	0.158 <i>f</i> <sup>0.5</sup>	4.21 x 10 <sup>-4</sup> <i>f</i> <sup>0.5</sup>	6.67 x 10 <sup>-5</sup> <i>f</i>	616000/ <i>f</i> <sup>1.2</sup>

**Note:** *f* is frequency in MHz.

\* Power density limit is applicable at frequencies greater than 100 MHz.

RF Field Strength Limits for Controlled Use Devices (Controlled Environment)

Frequency Range (MHz)	Electric Field (V/m rms)	Magnetic Field (A/m rms)	Power Density (W/m <sup>2</sup> )	Averaging Time (minutes)
0.003-1	600	4.9	-	6
1-10	600/ <i>f</i>	4.9/ <i>f</i>	-	6
10-30	60	4.9/ <i>f</i>	-	6
30-300	60	0.163	10*	6
300-1500	3.54 <i>f</i> <sup>0.5</sup>	0.0094 <i>f</i> <sup>0.5</sup>	<i>f</i> /30	6
1500-15000	137	0.364	50	6
15000-150000	137	0.364	50	616000/ <i>f</i> <sup>1.2</sup>
150000-300000	0.354 <i>f</i> <sup>0.5</sup>	9.4 x 10 <sup>-4</sup> <i>f</i> <sup>0.5</sup>	3.33 x 10 <sup>-4</sup> <i>f</i>	616000/ <i>f</i> <sup>1.2</sup>

**Note:** *f* is frequency in MHz.

\*Power density limit is applicable at frequencies greater than 100 MHz.

#### 4.1. Output Power into Antenna & RF Exposure Evaluation Distance for FCC

##### 4.1.1. Evaluation at 20 cm distance

Operation Frequency (MHz)	Channel No.	Channel	Output Peak Power (dBm)	Antenna Gain (dBi)	Power Density at 20 cm (mW/cm <sup>2</sup> )	LIMITS (mW/cm <sup>2</sup> )
<b>Max. output power with the tolerance</b>			2.5	0.7	0.00042	1

Note :

1. The power density at a distance of 20 cm calculated from the friis transmission formula is far below each limits.