

Application for FCC Certificate  
On Behalf of  
LG Electronics U.S.A., Inc.

LCD Monitor

Model No.: E2241SX

Serial No.: E2010101805

FCC ID : BEJE2241SX

Prepared For : LG Electronics U.S.A., Inc.  
1000 Sylvan Avenue, Englewood Cliffs,  
NJ 07632, United States

Prepared By : Audix Technology (Shanghai) Co., Ltd.  
3F 34Bldg 680 Guiping Rd,  
Caohejing Hi-Tech Park,  
Shanghai 200233, China

Tel: +86-21-64955500  
Fax: +86-21-64955491

Report No. : ACI-F10148  
Date of Test : Oct 20-Nov 01, 2010  
Date of Report : Nov 05, 2010

## TABLE OF CONTENTS

	Page
<b>1 SUMMARY OF STANDARDS AND RESULTS.....</b>	<b>4</b>
1.1 Description of Standards and Results.....	4
<b>2 GENERAL INFORMATION.....</b>	<b>5</b>
2.1 Description of Equipment Under Test.....	5
2.2 Peripherals.....	6
2.3 Description of Test Facility.....	7
2.4 Measurement Uncertainty.....	7
<b>3 CONDUCTED EMISSION TEST.....</b>	<b>8</b>
3.1 Test Equipment.....	8
3.2 Block Diagram of Test Setup.....	8
3.3 Conducted Emission Limit [FCC Part 15 Subpart B 15.107(a)].....	9
3.4 Test Configuration.....	9
3.5 Operating Condition of EUT.....	10
3.6 Test Procedures.....	10
3.7 Test Results.....	11
<b>4 RADIATED EMISSION TEST.....</b>	<b>16</b>
4.1 Test Equipment.....	16
4.2 Block Diagram of Test Setup.....	16
4.3 Radiated Emission Limit [FCC Part 15 Subpart B 15.109(a)].....	17
4.4 Test Configuration.....	17
4.5 Operating Condition of EUT.....	18
4.6 Test Procedures.....	18
4.7 Test Results.....	19
<b>5 DEVIATION TO TEST SPECIFICATIONS.....</b>	<b>27</b>
<b>6 DEBUG DESCRIPTION.....</b>	<b>28</b>



# 1 SUMMARY OF STANDARDS AND RESULTS

## 1.1 Description of Standards and Results

The EUT have been tested according to the applicable standards as referenced below:

<b>Description of Test Item</b>	<b>Standard</b>	<b>Limits</b>	<b>Results</b>
<b>EMISSION</b>			
Conducted Disturbance at the Mains Terminal	FCC RULES AND REGULATIONS PART 15 SUBPART B OCTOBER 2009 AND ANSI C63.4-2003	15.107(a) Class B	Pass
Radiated Disturbance	FCC RULES AND REGULATIONS PART 15 SUBPART B OCTOBER 2009 AND ANSI C63.4-2003	15.109(a) Class B	Pass

## 2 GENERAL INFORMATION

### 2.1 Description of Equipment Under Test

Description : LCD Monitor

Type of EUT :  Production  Pre-product  Pro-type

Model No. : E2241SX

Serial No. : E2010101805

Real Power : 24.2W

Applicant : LG Electronics U.S.A., Inc.  
1000 Sylvan Avenue, Englewood Cliffs,  
NJ 07632, United States

Manufacturer : LG Electronics Nanjing Display Co., Ltd.  
No.346, Yao Xin Road, Economic & Technical  
Development Zone, Nanjing, China

LCD Panel : Manufacturer: LG Display  
M/N : LM215WF4 (TL) (E1)

Max Resolution : 1920\*1080@60Hz

D-Sub Cable #1 : Shielded, Detachable, 1.85m,  
with two cores on cable

D-Sub Cable #2 : Shielded, Detachable, 1.50m,  
with two cores in connector

Power Cord : Unshielded, Detachable, 1.80m

Note : After evaluation, the D-Sub cable#1 was used in the test  
for they will cause the maximum emission.

**Remark:**

The EUT is a LCD Monitor which input/output ports as follows:

- (1) One D-Sub Port : Connected with PC
- (2) One AC In Port : Connected with Power

## 2.2 Peripherals

### 2.2.1 PC #1

Manufacturer : HP  
Model Number : dx7400MT  
Serial Number : CNG8130K89  
Power Cord : Unshielded, Detachable, 1.8m  
Certificate : FCC DoC; CE/EMC; VCCI; C-Tick; UL  
BSMI (R33001) 3C (A000111)  
MIC (E-A011-04-2659(B))

### 2.2.2 PC #2

Manufacturer : HP  
Model Number : dx7200MT  
Serial Number : CNG8130K89  
Power Cord : Unshielded, Detachable, 1.8m  
Certificate : FCC DoC; CE/EMC; VCCI; C-Tick; UL  
BSMI (R33001) 3C (A000111)  
MIC (E-A011-04-2659(B))

### 2.2.3 Printer

Manufacturer : HP  
Model Number : C3990A  
Serial Number : JPZX020487  
Data Cable : Shielded, Detachable, 1.5m  
Certificate : GS, CE/EMC, C-Tick, FCC DoC

### 2.2.4 Keyboard

Manufacturer : Microsoft  
Model Number : RT2300  
Serial Number : 7668200662248  
Data Cable : Shielded, Undetachable, 1.8m  
Certificate : CE/EMC, FCC DoC, VCCI, MIC, C-Tick,  
BSMI

### 2.2.5 Mouse

Manufacturer : Microsoft  
Model Number : RT2300  
Serial Number : 6965712071551  
Data Cable : Shielded, Undetachable, 1.8m.  
Certificate : CE/EMC, FCC DoC, VCCI, MIC, C-Tick,  
BSMI

### 2.2.6 Modem

Manufacturer : TP-LINK  
Model Number : TM-EC5658V  
Serial Number : 07123301053  
Data Cable : Shielded, Detachable, 1.8m  
Certificate : FCC DoC, CE/EMC, CCC

**Note: PC#1 was used in Conducted Emission test. PC#2 was used in Radiated Emission test.**

## 2.3 Description of Test Facility

Site Description (No.3 3m Chamber) : Sept. 17, 1998 file on  
Apr 29, 2009 Renewed  
Federal Communications Commission  
FCC Engineering Laboratory  
7435 Oakland Mills Road  
Columbia, MD 21046, USA

Name of Firm : Audix Technology (Shanghai) Co., Ltd.

Site Location : 3F 34Bldg 680 Guiping Rd,  
Caohejing Hi-Tech Park,  
Shanghai 200233, China

NVLAP Lab Code : 200371-0

## 2.4 Measurement Uncertainty

Conducted Emission Expanded Uncertainty: U = 1.26 dB  
Radiated Emission Expanded Uncertainty : U = 3.02 dB

### 3 CONDUCTED EMISSION TEST

#### 3.1 Test Equipment

The following test equipments are used during the conducted emission test in a shielded room:

Item	Type	Manufacturer	Model No.	Serial No.	Last Cal.	Next Cal.
1.	Test Receiver	R&S	ESCI	100841	Oct 15, 2010	Oct 15, 2011
2.	Artificial Mains Network (AMN)	R&S	ESH2-Z5	843890/011	Apr 02, 2010	Apr 02, 2011
3.	Line Impedance Stabilization Network (LISN)	Kyoritsu	KNW-407	8-1280-4	Apr 02, 2010	Apr 02, 2011
4.	50 Ω Coaxial Switch	Anritsu	MP59B	6200426389	Sep 19, 2010	Mar 19, 2011
5.	50Ω Terminator	Anritsu	BNC	001	Apr 02, 2010	Apr 02, 2011
6.	Software	Audix	E3	SET00200 9804M592	--	--

#### 3.2 Block Diagram of Test Setup

##### 3.2.1 EUT & Peripherals

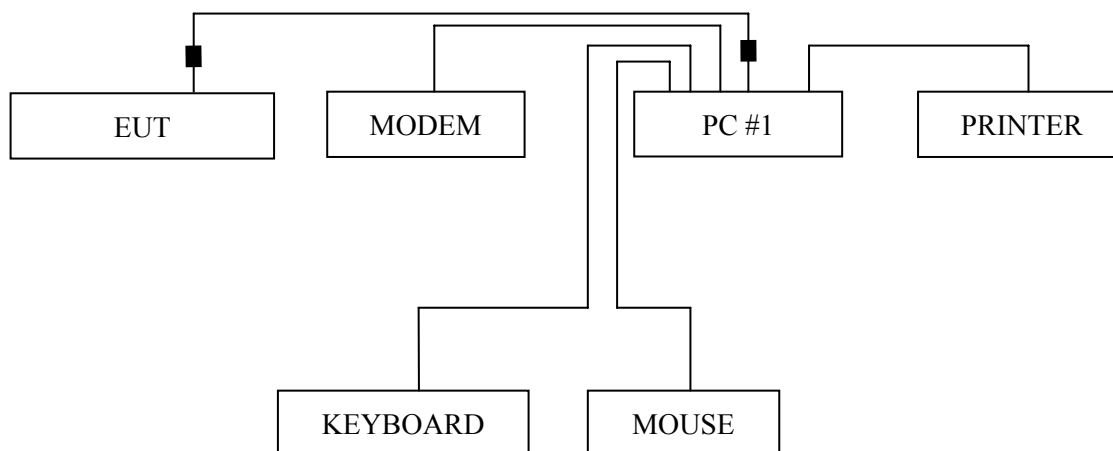

■ : Ferrite core

### 3.2.2 Conducted Disturbance Test Setup

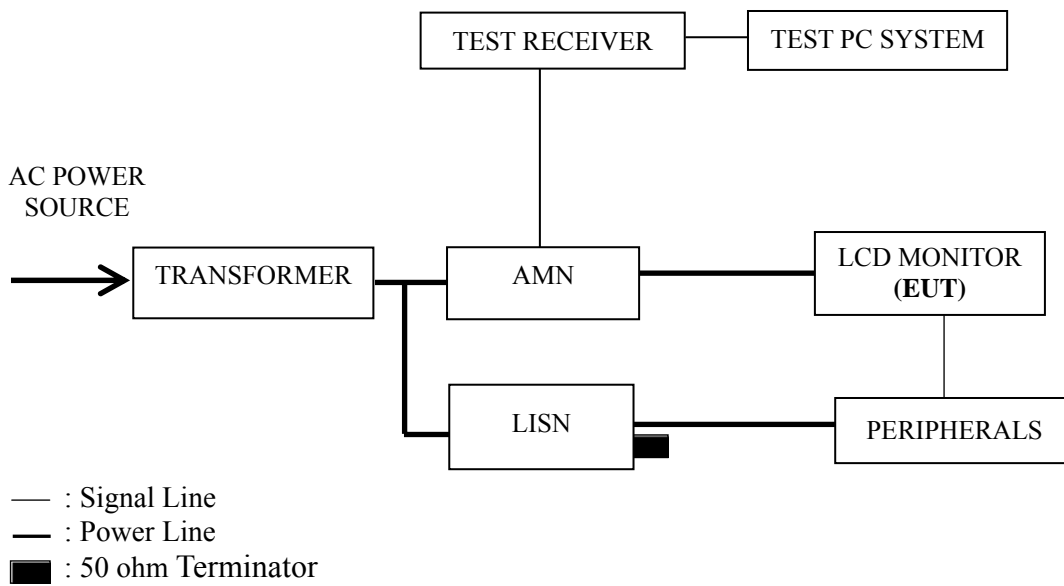

### 3.3 Conducted Emission Limit [FCC Part 15 Subpart B 15.107(a)]

Frequency Range (MHz)	Limits dB (μV)	
	Quasi-peak	Average
0.15 ~ 0.5	66~56	56~46
0.5 ~ 5	56	46
5 ~ 30	60	50

NOTE 1 – The lower limit shall apply at the transition frequencies.  
 NOTE 2 – The limit decreases linearly with the logarithm of the frequency in the range 0.15 MHz~0.50 MHz

### 3.4 Test Configuration

The EUT (listed in Sec.2.1) and the peripherals (listed in Sec 2.2) were installed as shown on Sec.3.2 to meet FCC requirement and operating in a manner that tends to maximize its emission level in a normal application.

### 3.5 Operating Condition of EUT

3.5.1 Setup the EUT and peripherals as shown in Sec. 3.2.

3.5.2 Turn on the power of all equipments and the EUT.

3.5.3 Set the contrast & brightness of EUT to maximum.

3.5.4 PC system ran the self-test program “EMC Test” by windows XP and sent “H” characters to EUT through graphic card, the EUT’s screen displayed and filled with “H” pattern by its resolution (Via D-Sub Input).

3.5.5 Repeat above procedure from 3.5.3 to 3.5.4 for difference test mode.

3.5.6 The other peripherals devices were driven and operated during the test.

3.5.7 The test modes are as follows:

Test Mode
D-Sub 640*480@60Hz
D-Sub 1280*1024@75Hz
D-Sub 1680*1050@60Hz
D-Sub 1920*1080@60Hz

### 3.6 Test Procedures

The EUT and peripherals were connected to the power mains through an Artificial Mains Network (AMN). This provided a 50 ohm coupling impedance for the measuring equipment.

Both sides of AC line (Line & Neutral) were checked for maximum conducted interference. In order to find the maximum emission, the relative positions of equipment and all of the interface cables were changed or manipulated according to ANSI C63.4:2003 during conducted emission test.

The bandwidth of R&S Test Receiver ESCI was set at 9 kHz.

The frequency range from 150 kHz to 30 MHz was checked.

The test modes were done on conducted disturbance test and all the test results are listed in Sec. 3.7.

### 3.7 Test Results

< **PASS** >

The frequency and amplitude of the highest conducted emission relative to the limit is reported. All emissions not reported below are too low against the prescribed limits.

Test Mode	Page
D-Sub 640*480@60Hz	P12
D-Sub 1280*1024@75Hz	P13
D-Sub1680*1050@60Hz	P14
<b>D-Sub 1920*1080@60Hz</b>	<b>P15</b>

NOTE 1 – The **bold test mode** listed above means the worst test mode.

NOTE 2 – Factor = Cable Loss + AMN Factor.

NOTE 3 – Emission Level = Meter Reading + Factor.

NOTE 4 – “QP” means “Quasi-Peak” values, “AV” means “Average” values.

NOTE 5 – The worst case is for D-Sub 1920\*1080@60Hz test mode. The worst emission is detected at 26.139 MHz (Quasi-Peak Value) with corrected signal level of 44.02 dB ( $\mu$ V) (limit is 60.00 dB ( $\mu$ V)), when the Line of the EUT is connected to AMN.

EUT : LCD Monitor Temperature : 22°C  
 Model No. : E2241SX Humidity : 48%RH  
 Serial No. : E2010101805 Date of Test : Nov 01, 2010  
 Test Mode : D-Sub 640\*480@60Hz

Test Line	Frequency (MHz)	Meter Reading dB(μV)	Factor (dB)	Emission Level dB(μV)	Limits dB(μV)	Margin (dB)	Remark
Line	0.200	40.34	0.38	40.72	63.62	22.90	QP
	0.406	33.42	0.48	33.90	57.73	23.83	
	3.025	36.10	0.70	36.80	56.00	19.20	
	7.446	34.75	0.92	35.67	60.00	24.33	
	10.342	35.55	1.07	36.62	60.00	23.38	
	26.139	40.23	1.83	42.06	60.00	17.94	
	0.200	31.25	0.38	31.63	53.62	21.99	AV
	0.406	23.15	0.48	23.63	47.73	24.10	
	3.025	26.35	0.70	27.05	46.00	18.95	
	7.446	24.57	0.92	25.49	50.00	24.51	
	10.342	25.65	1.07	26.72	50.00	23.28	
	26.139	23.63	1.83	25.46	50.00	24.54	
Neutral	0.202	41.53	0.30	41.83	63.54	21.71	QP
	0.406	33.75	0.44	34.19	57.73	23.54	
	2.962	31.40	0.65	32.05	56.00	23.95	
	8.822	29.39	0.97	30.36	60.00	29.64	
	16.398	30.64	1.56	32.20	60.00	27.80	
	26.139	40.41	1.89	42.30	60.00	17.70	
	0.202	31.26	0.30	31.56	53.54	21.98	AV
	0.406	23.14	0.44	23.58	47.73	24.15	
	2.962	21.35	0.65	22.00	46.00	24.00	
	8.822	16.54	0.97	17.51	50.00	32.49	
	16.398	20.33	1.56	21.89	50.00	28.11	
	<b>26.139</b>	<b>31.24</b>	<b>1.89</b>	<b>33.13</b>	<b>50.00</b>	<b>16.87</b>	

TEST ENGINEER: WENCY YANG

EUT :           LCD Monitor           Temperature :           22°C          

Model No. :           E2241SX           Humidity :           48%RH          

Serial No. :           E2010101805           Date of Test :           Nov 01, 2010          

Test Mode :           D-Sub 1280\*1024@75Hz          

Test Line	Frequency (MHz)	Meter Reading dB(μV)	Factor (dB)	Emission Level dB(μV)	Limits dB(μV)	Margin (dB)	Remark
Line	0.202	37.94	0.38	38.32	63.54	25.22	QP
	2.594	33.74	0.67	34.41	56.00	21.59	
	2.900	36.74	0.69	37.43	56.00	18.57	
	7.100	35.56	0.89	36.45	60.00	23.55	
	10.342	35.82	1.07	36.89	60.00	23.11	
	<b>26.139</b>	<b>40.92</b>	<b>1.83</b>	<b>42.75</b>	<b>60.00</b>	<b>17.25</b>	
	0.202	21.54	0.38	21.92	53.54	31.62	AV
	2.594	22.64	0.67	23.31	46.00	22.69	
	2.900	23.65	0.69	24.34	46.00	21.66	
	7.100	25.18	0.89	26.07	50.00	23.93	
10.342	25.31	1.07	26.38	50.00	23.62		
26.139	30.20	1.83	32.03	50.00	17.97		
Neutral	0.152	41.51	0.32	41.83	65.91	24.08	QP
	0.204	38.71	0.31	39.02	63.45	24.43	
	2.962	31.40	0.65	32.05	56.00	23.95	
	8.235	28.70	0.93	29.63	60.00	30.37	
	15.388	30.18	1.48	31.66	60.00	28.34	
	26.139	39.71	1.89	41.60	60.00	18.40	
	0.152	31.24	0.32	31.56	55.91	24.35	AV
	0.204	28.15	0.31	28.46	53.45	24.99	
	2.962	21.14	0.65	21.79	46.00	24.21	
	8.235	14.57	0.93	15.50	50.00	34.50	
	15.388	20.36	1.48	21.84	50.00	28.16	
	26.139	28.56	1.89	30.45	50.00	19.55	

TEST ENGINEER: WENCY YANG

EUT :           LCD Monitor                Temperature :           22°C          

Model No. :           E2241SX                Humidity :           48%RH          

Serial No. :           E2010101805                Date of Test :           Nov 01, 2010          

Test Mode :           D-Sub 1680\*1050@60Hz          

Test Line	Frequency (MHz)	Meter Reading dB(μV)	Factor (dB)	Emission Level dB(μV)	Limits dB(μV)	Margin (dB)	Remark
Line	0.202	39.25	0.38	39.63	63.54	23.91	QP
	0.611	32.37	0.52	32.89	56.00	23.11	
	2.962	34.96	0.70	35.66	56.00	20.34	
	7.446	34.30	0.92	35.22	60.00	24.78	
	10.072	35.66	1.06	36.72	60.00	23.28	
	<b>26.139</b>	<b>40.75</b>	<b>1.83</b>	<b>42.58</b>	<b>60.00</b>	<b>17.42</b>	
	0.202	21.47	0.38	21.85	53.54	31.69	AV
	0.611	21.54	0.52	22.06	46.00	23.94	
	2.962	24.57	0.70	25.27	46.00	20.73	
	7.446	24.15	0.92	25.07	50.00	24.93	
	10.072	25.63	1.06	26.69	50.00	23.31	
	26.139	23.33	1.83	25.16	50.00	24.84	
Neutral	0.204	39.68	0.31	39.99	63.45	23.46	QP
	0.406	32.28	0.44	32.72	57.73	25.01	
	2.993	31.68	0.65	32.33	56.00	23.67	
	8.592	28.73	0.95	29.68	60.00	30.32	
	15.552	30.83	1.50	32.33	60.00	27.67	
	24.529	39.21	1.87	41.08	60.00	18.92	
	0.204	29.57	0.31	29.88	53.45	23.57	AV
	0.406	21.35	0.44	21.79	47.73	25.94	
	2.993	21.35	0.65	22.00	46.00	24.00	
	8.592	15.58	0.95	16.53	50.00	33.47	
	15.552	20.35	1.50	21.85	50.00	28.15	
	24.529	21.56	1.87	23.43	50.00	26.57	

TEST ENGINEER: WENCY YANG

EUT :           LCD Monitor                Temperature :           22°C          

Model No. :           E2241SX                Humidity :           48%RH          

Serial No. :           E2010101805                Date of Test :           Nov 01, 2010          

Test Mode :           D-Sub 1920\*1080@60Hz          

Test Line	Frequency (MHz)	Meter Reading dB(μV)	Factor (dB)	Emission Level dB(μV)	Limits dB(μV)	Margin (dB)	Remark
Line	0.202	41.45	0.38	41.83	63.54	21.71	QP
	0.611	31.40	0.52	31.92	56.00	24.08	
	2.931	35.87	0.69	36.56	56.00	19.44	
	7.852	34.35	0.95	35.30	60.00	24.70	
	10.125	37.29	1.06	38.35	60.00	21.65	
	<b>26.139</b>	<b>42.19</b>	<b>1.83</b>	<b>44.02</b>	<b>60.00</b>	<b>15.98</b>	
	0.202	31.25	0.38	31.63	53.54	21.91	AV
	0.611	21.54	0.52	22.06	46.00	23.94	
	2.931	25.47	0.69	26.16	46.00	19.84	
	7.852	24.57	0.95	25.52	50.00	24.48	
	10.125	27.41	1.06	28.47	50.00	21.53	
	26.139	31.25	1.83	33.08	50.00	16.92	
Neutral	0.204	40.67	0.31	40.98	63.45	22.47	QP
	0.406	32.94	0.44	33.38	57.73	24.35	
	0.611	29.67	0.49	30.16	56.00	25.84	
	3.074	31.71	0.66	32.37	56.00	23.63	
	15.885	31.30	1.52	32.82	60.00	27.18	
	26.139	40.39	1.89	42.28	60.00	17.72	
	0.204	31.48	0.31	31.79	53.45	21.66	AV
	0.406	24.57	0.44	25.01	47.73	22.72	
	0.611	18.57	0.49	19.06	46.00	26.94	
	3.074	21.58	0.66	22.24	46.00	23.76	
	15.885	21.65	1.52	23.17	50.00	26.83	
	26.139	30.25	1.89	32.14	50.00	17.86	

TEST ENGINEER: WENCY YANG

## 4 RADIATED EMISSION TEST

### 4.1 Test Equipment

The following test equipments are used during the radiated emission test in a semi-anechoic chamber:

Item	Type	Manufacturer	Model No.	Serial No.	Last Cal.	Next Cal.
1.	Test Receiver	R&S	ESVS10	844594/001	Mar 07, 2010	Mar 07, 2011
2.	Preamplifier	Agilent	8447D	2944A10548	Sep 19, 2010	Mar 19, 2011
3.	Preamplifier	HP	8449B	3008A00864	Apr 29, 2010	Apr 29, 2011
4.	Bi-log Antenna	TESEQ	CBL6112D	23192	Dec 01, 2009	Dec 01, 2010
5.	Spectrum	Agilent	E7405A	MY45106600	May 19, 2010	May 19, 2011
6.	Software	Audix	E3	SET00200 9912M295-2	--	--

### 4.2 Block Diagram of Test Setup

#### 4.2.1 EUT and Peripherals

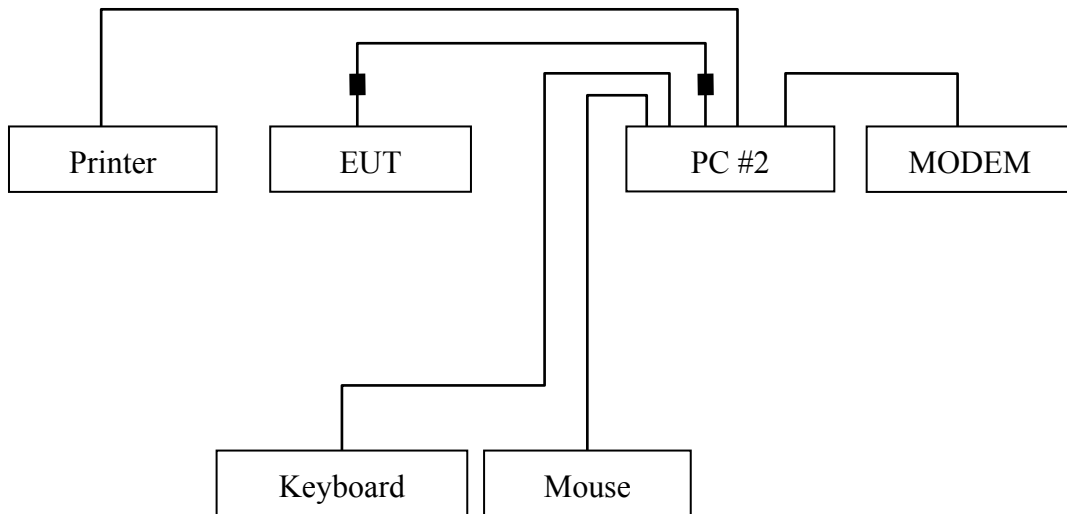

■: Ferrite core

### 4.2.2 Radiated emission test setup

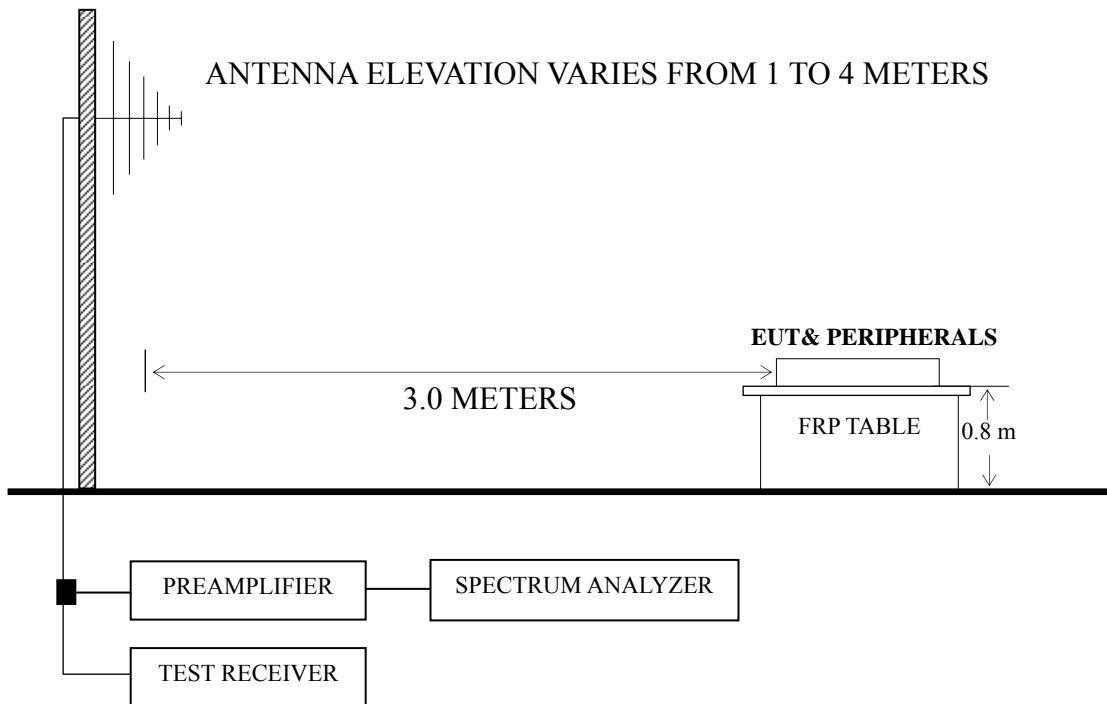

■ : 50 ohm Coaxial Switch

### 4.3 Radiated Emission Limit [FCC Part 15 Subpart B 15.109(a)]

Frequency (MHz)	Distance (m)	Field strength limits	
		( $\mu\text{V/m}$ )	dB ( $\mu\text{V/m}$ )
30 ~ 88	3	100	40.0
88 ~ 216	3	150	43.5
216 ~ 960	3	200	46.0
Above 960	3	500	54.0

NOTE 1 - Emission Level dB ( $\mu\text{V/m}$ ) = 20 log Emission Level ( $\mu\text{V/m}$ )  
 NOTE 2 - The tighter limit applies at the band edges.  
 NOTE 3 - Distance refers to the distance in meters between the measuring instrument antenna and the closed point of any part of the device or system.  
 NOTE 4 - The limits shown are based on Quasi-peak value detector below or equal to 1GHz and Average value detector above 1GHz.  
 NOTE 5 - Above 1 GHz, the limit on peak emission is 20 dB above the maximum permitted average emission limit applicable to the EUT.

### 4.4 Test Configuration

The configuration of the EUT and peripherals are same as those used in conducted emission test.

Please refer to Sec.3.4.

#### 4.5 Operating Condition of EUT

Same as conducted emission test which is listed in Sec.3.5, except for the test setup replaced by Sec.4.2.

#### 4.6 Test Procedures

The EUT and peripherals were placed on a FRP turntable that is 0.8 meter above ground. The FRP turntable rotated 360 degrees to determine the position of the maximum emission level. The EUT was set 3 meters away from the receiving antenna, which was mounted on an antenna tower. Broadband antenna (Calibrated Bilog Antenna) was used as receiving antenna. The antenna moved up and down between 1 meter and 4 meters to find out the maximum emission level. Both horizontal and vertical polarizations of the antenna were set on measurement. In order to find the maximum emission, all of the interference cables were manipulated according to ANSI C63.4:2003 requirements during radiated emission test.

The I.F. bandwidth of Test Receiver R&S ESVS10 was set at 120 kHz below 1GHz and The Spectrum Agilent E7405A was set at 1MHz above 1GHz.

The frequency range from 30 MHz to 1000MHz was checked for all test modes.

The frequency range from 1 GHz to 2 GHz was checked for D-Sub 1280\*1024@75Hz, D-Sub 1680\*1050@60Hz and D-Sub 1920\*1080@60Hz modes.

The test modes were done on radiated disturbance test and all the test results are listed in Sec.4.7.

## 4.7 Test Results

<PASS>

The frequency and amplitude of the highest radiated emission relative the limit is reported. All the emissions not reported below are too low against the FCC limit.

Test Mode	Page
D-Sub 640*480@60Hz	P20
D-Sub 1280*1024@75Hz	P21 – P22
<b>D-Sub1680*1050@60Hz</b>	<b>P23 – P24</b>
D-Sub 1920*1080@60Hz	P25 – P26

NOTE 1 – **The bold test mode** listed above means the worst test mode.

NOTE 2 – Emission Level = Antenna Factor + Cable Loss + Meter Reading. (< 1GHz)

NOTE 3 – Emission Level = Antenna Factor + Cable Loss – Preamp Factor + Meter Reading. (> 1GHz)

NOTE 4 – The emission levels that are 20dB below the official limit are not reported.

NOTE 5 – 0° was the table front facing the antenna. Degree is calculated from 0° clockwise facing the antenna.

NOTE 6 – The worst case is for D-Sub1680\*1050@60Hz test mode. The worst emission at horizontal polarization was detected at 33.880 MHz with corrected signal level of 36.51 dB (μV/m) (limit is 40.00dB (μV/m)), when the antenna was 1.00 m height and the turntable was at 220°. The worst emission at vertical polarization was detected at 84.630 MHz with corrected signal level of 37.81 dB (μV/m) (limit is 40.00 dB (μV/m)), when the antenna was 1.00 m height and the turntable was at 340°.

EUT :           LCD Monitor                Temperature :           22°C          

Model No. :           E2241SX                Humidity :           60%RH          

Serial No. :           E2010101805                Date of Test :           Oct 20, 2010          

Test Mode :           D-Sub 640\*480@60Hz          

Polarization	Frequency (MHz)	Meter Reading dB (μV)	Antenna Factor (dB/m)	Cable Loss (dB)	Emission Level dB (μV/m)	Limits dB (μV/m)	Margin (dB)
Horizontal	<b>33.880</b>	<b>19.35</b>	<b>17.44</b>	<b>0.67</b>	<b>37.46</b>	<b>40.00</b>	<b>2.54</b>
	109.540	16.77	12.25	1.08	30.10	43.50	13.40
	174.530	17.68	10.07	1.35	29.10	43.50	14.40
	232.730	19.14	12.24	1.55	32.93	46.00	13.07
	364.650	16.81	15.73	1.96	34.50	46.00	11.50
	803.090	10.09	20.73	2.90	33.72	46.00	12.28
Vertical	86.560	26.00	8.84	0.98	35.82	40.00	4.18
	153.190	20.57	11.04	1.25	32.86	43.50	10.64
	218.180	22.16	11.52	1.51	35.19	46.00	10.81
	<b>324.880</b>	<b>25.69</b>	<b>14.58</b>	<b>1.84</b>	<b>42.11</b>	<b>46.00</b>	<b>3.89</b>
	368.530	23.18	15.81	1.98	40.97	46.00	5.03
	904.940	15.10	21.73	3.04	39.87	46.00	6.13

TEST ENGINEER: RAVEN JIN

EUT :           LCD Monitor                Temperature :           22°C          

Model No. :           E2241SX                Humidity :           60%RH          

Serial No. :           E2010101805                Date of Test :           Oct 20, 2010          

Test Mode :           D-Sub 1280\*1024@75Hz          

Polarization	Frequency (MHz)	Meter Reading dB (µV)	Antenna Factor (dB/m)	Cable Loss (dB)	Preamp Factor (dB)	Emission Level dB (µV/m)	Limits dB (µV/m)	Margin (dB)	Remark
Horizontal	<b>84.700</b>	<b>26.70</b>	<b>8.54</b>	<b>0.97</b>	--	<b>36.21</b>	<b>40.00</b>	<b>3.79</b>	QP
	145.430	26.27	11.66	1.23	--	39.16	43.50	4.34	
	182.290	25.11	9.99	1.38	--	36.48	43.50	7.02	
	368.530	20.27	15.81	1.98	--	38.06	46.00	7.94	
	589.690	10.18	19.09	2.43	--	31.70	46.00	14.30	
	807.940	12.63	20.77	2.90	--	36.30	46.00	9.70	
	1074.000	51.56	25.21	4.50	37.26	44.01	74.00	29.99	PK
	1205.000	48.99	25.85	4.51	37.00	42.35	74.00	31.65	
	1379.000	47.39	26.63	4.54	36.58	41.98	74.00	32.02	
	1501.000	48.17	27.00	4.55	36.28	43.44	74.00	30.56	
	1593.000	49.54	27.07	4.56	36.11	45.06	74.00	28.94	
	1673.000	47.04	27.14	4.57	35.98	42.77	74.00	31.23	
	1074.000	44.56	25.21	4.50	37.26	37.01	54.00	16.99	AV
	1205.000	35.99	25.85	4.51	37.00	29.35	54.00	24.65	
	1379.000	36.39	26.63	4.54	36.58	30.98	54.00	23.02	
	1501.000	38.17	27.00	4.55	36.28	33.44	54.00	20.56	
1593.000	41.54	27.07	4.56	36.11	37.06	54.00	16.94		
1673.000	41.04	27.14	4.57	35.98	36.77	54.00	17.23		

TEST ENGINEER: RAVEN JIN

EUT :           LCD Monitor                Temperature :           22°C          

Model No. :           E2241SX                Humidity :           60%RH          

Serial No. :           E2010101805                Date of Test :           Oct 20, 2010          

Test Mode :           D-Sub 1280\*1024@75Hz          

Polarization	Frequency (MHz)	Meter Reading dB (µV)	Antenna Factor (dB/m)	Cable Loss (dB)	Preamp Factor (dB)	Emission Level dB (µV/m)	Limits dB (µV/m)	Margin (dB)	Remark
Vertical	<b>33.880</b>	<b>19.20</b>	<b>17.44</b>	<b>0.67</b>	--	<b>37.31</b>	<b>40.00</b>	<b>2.69</b>	QP
	72.680	21.78	6.85	0.91	--	29.54	40.00	10.46	
	85.290	21.71	8.66	0.97	--	31.34	40.00	8.66	
	232.730	21.90	12.24	1.55	--	35.69	46.00	10.31	
	363.680	20.25	15.69	1.96	--	37.90	46.00	8.10	
	683.780	20.64	19.62	2.65	--	42.91	46.00	3.09	
	1148.000	54.35	25.56	4.51	37.12	47.30	74.00	26.70	PK
	1223.000	45.28	25.95	4.52	36.95	38.80	74.00	35.20	
	1453.000	43.25	26.87	4.55	36.39	38.28	74.00	35.72	
	1602.000	44.62	27.08	4.56	36.09	40.17	74.00	33.83	
	1639.000	45.41	27.11	4.57	36.03	41.06	74.00	32.94	
	1706.000	43.13	27.18	4.57	35.93	38.95	74.00	35.05	
	1148.000	47.35	25.56	4.51	37.12	40.30	54.00	13.70	AV
	1223.000	32.28	25.95	4.52	36.95	25.80	54.00	28.20	
	1453.000	29.25	26.87	4.55	36.39	24.28	54.00	29.72	
	1602.000	33.62	27.08	4.56	36.09	29.17	54.00	24.83	
	1639.000	37.41	27.11	4.57	36.03	33.06	54.00	20.94	
	1706.000	34.13	27.18	4.57	35.93	29.95	54.00	24.05	

TEST ENGINEER: RAVEN JIN

EUT :           LCD Monitor                Temperature :           22°C          

Model No. :           E2241SX                Humidity :           60%RH          

Serial No. :           E2010101805                Date of Test :           Oct 20, 2010          

Test Mode :           D-Sub 1680\*1050@60Hz          

Polarization	Frequency (MHz)	Meter Reading dB (µV)	Antenna Factor (dB/m)	Cable Loss (dB)	Preamp Factor (dB)	Emission Level dB (µV/m)	Limits dB (µV/m)	Margin (dB)	Remark
Horizontal	<b>33.880</b>	<b>18.40</b>	<b>17.44</b>	<b>0.67</b>	--	<b>36.51</b>	<b>40.00</b>	<b>3.49</b>	QP
	87.230	19.11	8.96	0.98	--	29.05	40.00	10.95	
	117.300	13.75	12.84	1.12	--	27.71	43.50	15.79	
	232.730	22.24	12.24	1.55	--	36.03	46.00	9.97	
	366.590	19.11	15.77	1.98	--	36.86	46.00	9.14	
	681.840	13.51	19.62	2.63	--	35.76	46.00	10.24	
	1091.000	45.30	25.28	4.50	37.23	37.85	74.00	36.15	PK
	1205.000	41.99	25.85	4.51	37.00	35.35	74.00	38.65	
	1441.000	41.31	26.83	4.55	36.43	36.26	74.00	37.74	
	1501.000	42.17	27.00	4.55	36.28	37.44	74.00	36.56	
	1593.000	43.54	27.07	4.56	36.11	39.06	74.00	34.94	
	1664.000	41.34	27.14	4.57	36.00	37.05	74.00	36.95	
	1091.000	39.30	25.28	4.50	37.23	31.85	54.00	22.15	AV
	1205.000	28.99	25.85	4.51	37.00	22.35	54.00	31.65	
	1441.000	28.31	26.83	4.55	36.43	23.26	54.00	30.74	
	1501.000	30.17	27.00	4.55	36.28	25.44	54.00	28.56	
	1593.000	34.54	27.07	4.56	36.11	30.06	54.00	23.94	
	1664.000	34.34	27.14	4.57	36.00	30.05	54.00	23.95	

TEST ENGINEER: RAVEN JIN

EUT :           LCD Monitor                Temperature :           22°C          

Model No. :           E2241SX                Humidity :           60%RH          

Serial No. :           E2010101805                Date of Test :           Oct 20, 2010          

Test Mode :           D-Sub 1680\*1050@60Hz          

Polarization	Frequency (MHz)	Meter Reading dB (µV)	Antenna Factor (dB/m)	Cable Loss (dB)	Preamp Factor (dB)	Emission Level dB (µV/m)	Limits dB (µV/m)	Margin (dB)	Remark
Vertical	<b>84.630</b>	<b>28.30</b>	<b>8.54</b>	<b>0.97</b>	--	<b>37.81</b>	<b>40.00</b>	<b>2.19</b>	QP
	135.730	17.14	12.28	1.19	--	30.61	43.50	12.89	
	225.940	19.71	11.94	1.53	--	33.18	46.00	12.82	
	366.590	21.05	15.77	1.98	--	38.80	46.00	7.20	
	589.690	11.37	19.09	2.43	--	32.89	46.00	13.11	
	999.030	9.48	22.40	4.49	--	36.37	54.00	17.63	
	1076.000	50.20	25.21	4.50	37.26	42.65	74.00	31.35	PK
	1275.000	43.56	26.21	4.53	36.84	37.46	74.00	36.54	
	1453.000	43.25	26.87	4.55	36.39	38.28	74.00	35.72	
	1602.000	43.62	27.08	4.56	36.09	39.17	74.00	34.83	
	1639.000	43.41	27.11	4.57	36.03	39.06	74.00	34.94	
	1729.000	40.19	27.20	4.57	35.90	36.06	74.00	37.94	
	1076.000	46.20	25.21	4.50	37.26	38.65	54.00	15.35	AV
	1275.000	31.56	26.21	4.53	36.84	25.46	54.00	28.54	
	1453.000	29.25	26.87	4.55	36.39	24.28	54.00	29.72	
	1602.000	28.62	27.08	4.56	36.09	24.17	54.00	29.83	
	1639.000	36.41	27.11	4.57	36.03	32.06	54.00	21.94	
	1729.000	29.19	27.20	4.57	35.90	25.06	54.00	28.94	

TEST ENGINEER: RAVEN JIN

EUT :           LCD Monitor                Temperature :           22°C          

Model No. :           E2241SX                Humidity :           60%RH          

Serial No. :           E2010101805                Date of Test :           Oct 20, 2010          

Test Mode :           D-Sub 1920\*1080@60Hz          

Polarization	Frequency (MHz)	Meter Reading dB (µV)	Antenna Factor (dB/m)	Cable Loss (dB)	Preamp Factor (dB)	Emission Level dB (µV/m)	Limits dB (µV/m)	Margin (dB)	Remark
Horizontal	72.680	27.39	6.85	0.91	--	35.15	40.00	4.85	QP
	87.230	26.69	8.96	0.98	--	36.63	40.00	3.37	
	145.430	26.27	11.66	1.23	--	39.16	43.50	4.34	
	324.880	25.41	14.58	1.84	--	41.83	46.00	4.17	
	<b>368.530</b>	<b>25.27</b>	<b>15.81</b>	<b>1.98</b>	--	<b>43.06</b>	<b>46.00</b>	<b>2.94</b>	
	807.940	14.63	20.77	2.90	--	38.30	46.00	7.70	PK
	1074.000	55.56	25.21	4.50	37.26	48.01	74.00	25.99	
	1205.000	48.99	25.85	4.51	37.00	42.35	74.00	31.65	
	1407.000	50.06	26.73	4.54	36.51	44.82	74.00	29.18	
	1501.000	49.17	27.00	4.55	36.28	44.44	74.00	29.56	
	1612.000	48.40	27.09	4.56	36.07	43.98	74.00	30.02	AV
	1732.000	44.98	27.20	4.57	35.90	40.85	74.00	33.15	
	1074.000	45.56	25.21	4.50	37.26	38.01	54.00	15.99	
	1205.000	36.99	25.85	4.51	37.00	30.35	54.00	23.65	
	1407.000	37.06	26.73	4.54	36.51	31.82	54.00	22.18	
1501.000	36.17	27.00	4.55	36.28	31.44	54.00	22.56		
1612.000	39.40	27.09	4.56	36.07	34.98	54.00	19.02		
	1732.000	34.98	27.20	4.57	35.90	30.85	54.00	23.15	

TEST ENGINEER: RAVEN JIN

EUT :           LCD Monitor                Temperature :           22°C          

Model No. :           E2241SX                Humidity :           60%RH          

Serial No. :           E2010101805                Date of Test :           Oct 20, 2010          

Test Mode :           D-Sub 1920\*1080@60Hz          

Polarization	Frequency (MHz)	Meter Reading dB (µV)	Antenna Factor (dB/m)	Cable Loss (dB)	Preamplifier Factor (dB)	Emission Level dB (µV/m)	Limits dB (µV/m)	Margin (dB)	Remark
Vertical	33.880	15.81	17.44	0.67	--	33.92	40.00	6.08	QP
	85.290	24.71	8.66	0.97	--	34.34	40.00	5.66	
	182.290	26.85	9.99	1.38	--	38.22	43.50	5.28	
	232.730	24.90	12.24	1.55	--	38.69	46.00	7.31	
	363.680	21.25	15.69	1.96	--	38.90	46.00	7.10	
	<b>683.780</b>	<b>18.64</b>	<b>19.62</b>	<b>2.65</b>	<b>--</b>	<b>40.91</b>	<b>46.00</b>	<b>5.09</b>	
	1076.000	55.20	25.21	4.50	37.26	47.65	74.00	26.35	PK
	1148.000	52.35	25.56	4.51	37.12	45.30	74.00	28.70	
	1280.000	52.18	26.23	4.53	36.83	46.11	74.00	27.89	
	1568.000	45.17	27.06	4.56	36.16	40.63	74.00	33.37	
	1639.000	46.41	27.11	4.57	36.03	42.06	74.00	31.94	
	1692.000	45.38	27.16	4.57	35.96	41.15	74.00	32.85	
	1076.000	45.20	25.21	4.50	37.26	37.65	54.00	16.35	AV
	1148.000	37.35	25.56	4.51	37.12	30.30	54.00	23.70	
	1280.000	38.18	26.23	4.53	36.83	32.11	54.00	21.89	
	1568.000	30.17	27.06	4.56	36.16	25.63	54.00	28.37	
	1639.000	38.41	27.11	4.57	36.03	34.06	54.00	19.94	
	1692.000	34.38	27.16	4.57	35.96	30.15	54.00	23.85	

TEST ENGINEER: RAVEN JIN

## **5 DEVIATION TO TEST SPECIFICATIONS**

None.

## 6 DEBUG DESCRIPTION

The following components are used during the countermeasure procedures:

Name	M/N	Specifications (mm)	Manufacturer	Location
Conductive Sponge	LG END 3940TKK 43C	90*10*2	EXPAN Electronics SUZHOU Co., Ltd.	See Internal photos Figure 12
Aluminum foil	T-308	50*30	DAEHUNG SUBSIDIARY MATERIALS.	See Internal photos Figure 13

Note: We had required the applicant and manufacturer that all electrical and mechanical devices employed for spurious radiation suppression, including any modifications made during certification testing, must be incorporated in each unit marked

TEST ENGINEER:

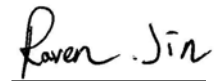

**(RAVEN JIN)**