

Application for FCC Certificate
On Behalf of
LG Electronics U.S.A., Inc.

LCD Monitor

Model No.: E1948SX

Serial No.: E1103050-01/01

FCC ID : BEJE1948SX

Prepared For : LG Electronics U.S.A., Inc.
1000 Sylvan Avenue, Englewood Cliffs,
NJ 07632, United States

Prepared By : Audix Technology (Shanghai) Co., Ltd.
3F 34Bldg 680 Guiping Rd,
Caohejing Hi-Tech Park,
Shanghai 200233, China

Tel: +86-21-64955500
Fax: +86-21-64955491

Report No. : ACI-F11035
Date of Test : Mar 15 – 16, 2011
Date of Report : Mar 28, 2011

TABLE OF CONTENTS

	Page
1 SUMMARY OF STANDARDS AND RESULTS.....	4
1.1 Description of Standards and Results.....	4
2 GENERAL INFORMATION.....	5
2.1 Description of Equipment Under Test.....	5
2.2 Peripherals.....	6
2.3 Description of Test Facility.....	7
2.4 Measurement Uncertainty.....	7
3 CONDUCTED EMISSION TEST.....	8
3.1 Test Equipment.....	8
3.2 Block Diagram of Test Setup.....	8
3.3 Conducted Emission Limit [FCC Part 15 Subpart B 15.107(a)].....	9
3.4 Test Configuration.....	9
3.5 Operating Condition of EUT.....	10
3.6 Test Procedures.....	10
3.7 Test Results.....	11
4 RADIATED EMISSION TEST.....	15
4.1 Test Equipment.....	15
4.2 Block Diagram of Test Setup.....	15
4.3 Radiated Emission Limit [FCC Part 15 Subpart B 15.109(a)].....	16
4.4 Test Configuration.....	16
4.5 Operating Condition of EUT.....	17
4.6 Test Procedures.....	17
4.7 Test Results.....	18
5 DEVIATION TO TEST SPECIFICATIONS.....	24

1 SUMMARY OF STANDARDS AND RESULTS

1.1 Description of Standards and Results

The EUT have been tested according to the applicable standards as referenced below:

Description of Test Item	Standard	Limits	Results
EMISSION			
Conducted Disturbance at the Mains Terminal	FCC RULES AND REGULATIONS PART 15 SUBPART B OCTOBER 2009 AND ANSI C63.4-2003	15.107(a) Class B	Pass
Radiated Disturbance	FCC RULES AND REGULATIONS PART 15 SUBPART B OCTOBER 2009 AND ANSI C63.4-2003	15.109(a) Class B	Pass

2 GENERAL INFORMATION

2.1 Description of Equipment Under Test

Description : LCD Monitor

Type of EUT : Production Pre-product Pro-type

Model No. : E1948SX

Serial No. : E1103050-01/01

Real Power : 18.80W

Applicant : LG Electronics U.S.A., Inc.
1000 Sylvan Avenue, Englewood Cliffs,
NJ 07632, United States

Manufacturer : LG Electronics Nanjing Display Co., Ltd.
No.346, Yao Xin Road, Economic & Technical
Development Zone, Nanjing, China

Adaptor : Manufacturer: HONOR
M/N : ADS-24S-12 1224GPCN
Input : 100-240V~, 50/60Hz 0.7A
Output : 12V  2.0A
Output Cable : Unshielded, Undetachable, 1.5m,
with one core

LCD Panel : Manufacturer: LG Display
M/N : LGM190MWW3

Max Resolution : 1440*900@60Hz

D-Sub Cable #1 : Shielded, Detachable, 1.50m,
with two cores on cable

D-Sub Cable #2 : Shielded, Detachable, 1.50m,
with two cores in connector

Note : The D-Sub cable#2 was selected to be used in the test.

Remark:

The EUT is a LCD Monitor which input/output ports as follows:

- (1) One D-Sub Port : Connected with PC
- (2) One DC In Port : Connected with Adaptor

2.2 Peripherals

2.2.1 PC #1

Manufacturer : HP
Model Number : dx7400MT
Serial Number : CNG8130K89
Power Cord : Unshielded, Detachable, 1.8m
Certificate : FCC DoC; CE/EMC; VCCI; C-Tick; UL
BSMI (R33001) 3C (A000111)
MIC (E-A011-04-2659(B))

2.2.2 PC #2

Manufacturer : HP
Model Number : dx7200MT
Serial Number : CNG622017W
Power Cord : Unshielded, Detachable, 1.8m
Certificate : FCC DoC; CE/EMC; VCCI; C-Tick; UL
BSMI (R33001) 3C (A000111)
MIC (E-A011-04-2659(B))

2.2.3 Printer

Manufacturer : HP
Model Number : C3990A
Serial Number : JPZX020487
Data Cable : Shielded, Detachable, 1.5m
Certificate : GS, CE/EMC, C-Tick, FCC DoC

2.2.4 Keyboard

Manufacturer : Microsoft
Model Number : KU-0459
Serial Number : 7691402450604
Data Cable : Shielded, Undetachable, 1.8m
Certificate : CE/EMC, FCC DoC, VCCI, MIC,
C-Tick, BSMI

2.2.5 Mouse

Manufacturer : DELL
Model Number : MO56UO
Serial Number : 443048231
Data Cable : Shielded, Undetachable, 1.8m.
Certificate : CE/EMC, FCC DoC, VCCI, MIC,
C-Tick, BSMI

2.2.6 Modem

Manufacturer : TP-LINK
Model Number : TM-EC5658V
Serial Number : 07123301053
Data Cable : Shielded, Detachable, 1.8m
Certificate : FCC DoC, CE/EMC, CCC

Note: PC #1 was used in Conducted Emission Test while PC #2 was used in Radiated Emission Test.

2.3 Description of Test Facility

Site Description (Semi-Anechoic Chamber)	:	Sept. 17, 1998 file on Apr 29, 2009 Renewed Federal Communications Commission FCC Engineering Laboratory 7435 Oakland Mills Road Columbia, MD 21046, USA
Name of Firm	:	Audix Technology (Shanghai) Co., Ltd.
Site Location	:	3F 34Bldg 680 Guiping Rd, Caohejing Hi-Tech Park, Shanghai 200233, China
NVLAP Lab Code	:	200371-0

2.4 Measurement Uncertainty

Conducted Emission Expanded Uncertainty : $U = 3.38\text{dB}$

Radiated Emission Expanded Uncertainty (30MHz - 200MHz):

$U = 4.58\text{dB}$ (Horizontal)

$U = 4.70\text{dB}$ (Vertical)

Radiated Emission Expanded Uncertainty (200MHz - 1GHz):

$U = 4.84\text{dB}$ (Horizontal)

$U = 4.70\text{dB}$ (Vertical)

3 CONDUCTED EMISSION TEST

3.1 Test Equipment

The following test equipments are used during the conducted emission test in a shielded room:

Item	Type	Manufacturer	Model No.	Serial No.	Last Cal.	Next Cal.
1.	Test Receiver	R&S	ESCI	100841	Oct 15, 2010	Oct 15, 2011
2.	Artificial Mains Network (AMN)	R&S	ESH2-Z5	843890/011	Apr 02, 2010	Apr 02, 2011
3.	Line Impedance Stabilization Network (LISN)	Kyoritsu	KNW-407	8-1280-4	Apr 02, 2010	Apr 02, 2011
4.	50 Ω Coaxial Switch	Anritsu	MP59B	6200426389	Sep 19, 2010	Mar 19, 2011
5.	50Ω Terminator	Anritsu	BNC	001	Apr 02, 2010	Apr 02, 2011
6.	Software	Audix	E3	SET00200 9804M592	--	--

3.2 Block Diagram of Test Setup

3.2.1 EUT & Peripherals

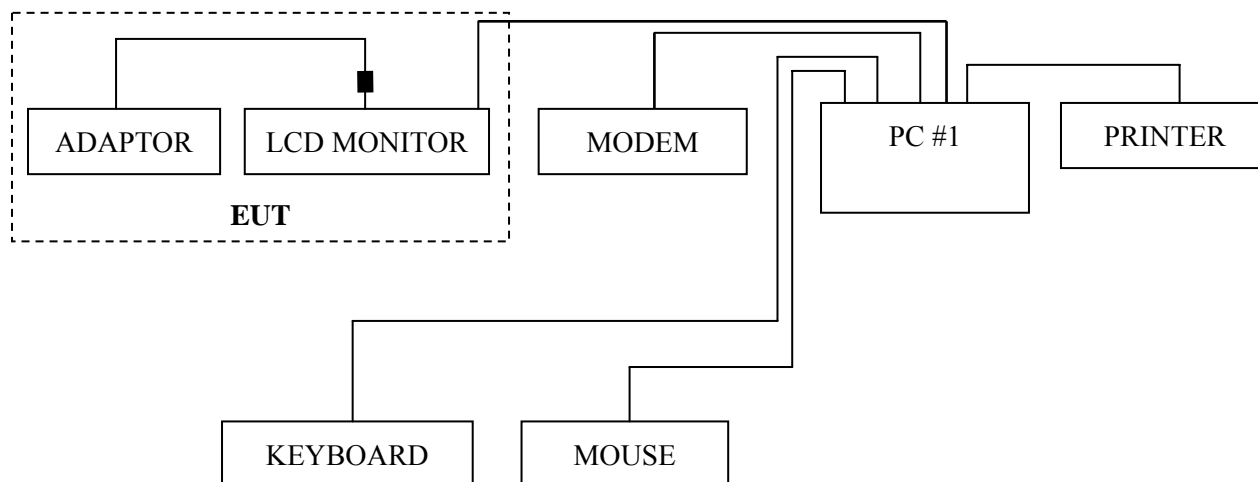

■ : Ferrite core

3.2.2 Conducted Disturbance Test Setup

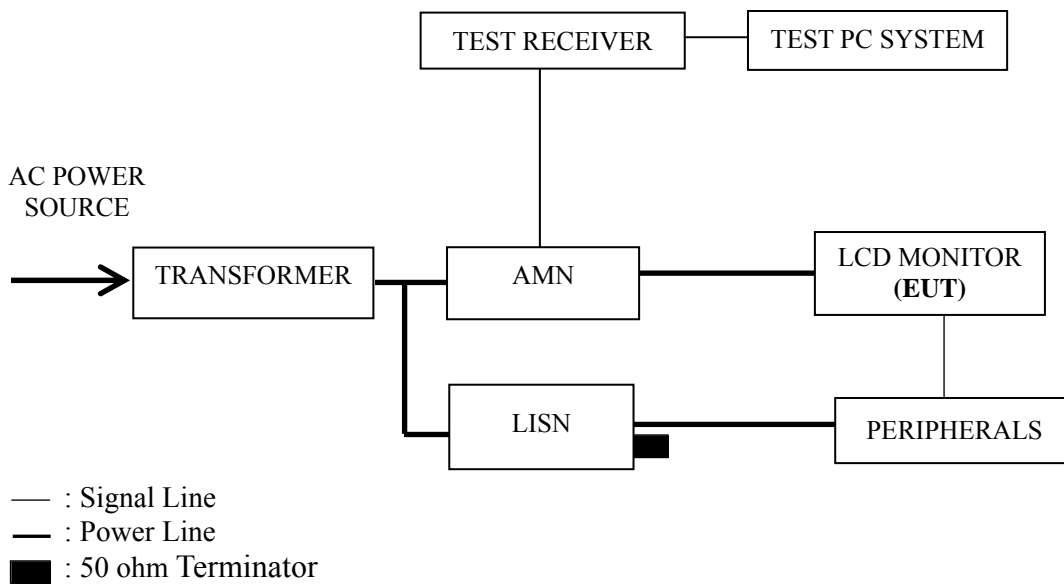

3.3 Conducted Emission Limit [FCC Part 15 Subpart B 15.107(a)]

Frequency Range (MHz)	Limits dB (μV)	
	Quasi-peak	Average
0.15 ~ 0.5	66~56	56~46
0.5 ~ 5	56	46
5 ~ 30	60	50

NOTE 1 – The lower limit shall apply at the transition frequencies.
 NOTE 2 – The limit decreases linearly with the logarithm of the frequency in the range 0.15 MHz~0.50 MHz

3.4 Test Configuration

The EUT (listed in Sec.2.1) and the peripherals (listed in Sec 2.2) were installed as shown on Sec.3.2 to meet FCC requirement and operating in a manner that tends to maximize its emission level in a normal application.

3.5 Operating Condition of EUT

3.5.1 Setup the EUT and peripherals as shown in Sec. 3.2.

3.5.2 Turn on the power of all equipments and the EUT.

3.5.3 Set the contrast & brightness of EUT to maximum.

3.5.4 PC system ran the self-test program “EMC Test” by windows XP and sent “H” characters to EUT through graphic card, the EUT’s screen displayed and filled with “H” pattern by its resolution (Via D-Sub Input).

3.5.5 Repeat above procedure from 3.5.3 to 3.5.4 for difference test mode.

3.5.6 The other peripherals devices were driven and operated during the test.

3.5.7 The test modes are as follows:

Test Mode
D-Sub 640*480@60Hz
D-Sub 1280*1024@75Hz
D-Sub 1440*900@60Hz

3.6 Test Procedures

The EUT and peripherals were connected to the power mains through an Artificial Mains Network (AMN). This provided a 50 ohm coupling impedance for the measuring equipment.

Both sides of AC line (Line & Neutral) were checked for maximum conducted interference. In order to find the maximum emission, the relative positions of equipment and all of the interface cables were changed or manipulated according to ANSI C63.4:2003 during conducted emission test.

The bandwidth of R&S Test Receiver ESCI was set at 9 kHz.

The frequency range from 150 kHz to 30 MHz was checked.

The test modes were done on conducted disturbance test and all the test results are listed in Sec. 3.7.

3.7 Test Results

< **PASS** >

The frequency and amplitude of the highest conducted emission relative to the limit is reported. All emissions not reported below are too low against the prescribed limits.

Test Mode	Page
D-Sub 640*480@60Hz	P12
D-Sub 1280*1024@75Hz	P13
D-Sub 1440*900@60Hz	P14

NOTE 1 – The **bold test mode** listed above means the worst test mode.

NOTE 2 – Factor = Cable Loss + AMN Factor.

NOTE 3 – Emission Level = Meter Reading + Factor.

NOTE 4 – “QP” means “Quasi-Peak” values, “AV” means “Average” values.

NOTE 5 – The worst case is for D-Sub 1280*1024@75Hz test mode. The worst emission is detected at 0.162 MHz (Average Value) with corrected signal level of 47.20 dB (μ V) (limit is 55.34 dB (μ V)), when the Neutral of the EUT is connected to AMN.

EUT : LCD Monitor Temperature : 22°C

Model No. : E1948SX Humidity : 48%RH

Serial No. : E1103050-01/01 Date of Test : Mar 15, 2011

Test Mode : D-Sub 640*480@60Hz

Test Line	Frequency (MHz)	Meter Reading dB(μV)	Factor (dB)	Emission Level dB(μV)	Limits dB(μV)	Margin (dB)	Remark
Line	0.161	55.23	0.38	55.61	65.43	9.82	QP
	0.242	46.51	0.41	46.92	62.04	15.12	
	0.516	31.36	0.52	31.88	56.00	24.12	
	3.759	42.45	0.74	43.19	56.00	12.81	
	5.277	36.71	0.82	37.53	60.00	22.47	
	26.418	28.18	1.83	30.01	60.00	29.99	
	0.161	46.46	0.38	46.84	55.43	8.59	AV
	0.242	37.80	0.41	38.21	52.04	13.83	
	0.516	20.10	0.52	20.62	46.00	25.38	
	3.759	34.17	0.74	34.91	46.00	11.09	
	5.277	28.20	0.82	29.02	50.00	20.98	
	26.418	25.50	1.83	27.33	50.00	22.67	
Neutral	0.162	55.48	0.32	55.80	65.34	9.54	QP
	0.242	46.31	0.34	46.65	62.04	15.39	
	0.521	31.92	0.49	32.41	56.00	23.59	
	3.681	41.08	0.69	41.77	56.00	14.23	
	7.526	34.88	0.89	35.77	60.00	24.23	
	28.302	27.48	1.91	29.39	60.00	30.61	
	0.162	46.71	0.32	47.03	55.34	8.31	AV
	0.242	37.50	0.34	37.84	52.04	14.20	
	0.521	20.76	0.49	21.25	46.00	24.75	
	3.681	33.40	0.69	34.09	46.00	11.91	
	7.526	25.64	0.89	26.53	50.00	23.47	
	28.302	23.36	1.91	25.27	50.00	24.73	

TEST ENGINEER: WENCY YANG

EUT : LCD Monitor Temperature : 22°C

Model No. : E1948SX Humidity : 48%RH

Serial No. : E1103050-01/01 Date of Test : Mar 15, 2011

Test Mode : D-Sub 1280*1024@75Hz

Test Line	Frequency (MHz)	Meter Reading dB(μV)	Factor (dB)	Emission Level dB(μV)	Limits dB(μV)	Margin (dB)	Remark
Line	0.162	55.86	0.38	56.24	65.34	9.10	QP
	0.247	46.91	0.41	47.32	61.86	14.54	
	0.505	30.92	0.52	31.44	56.00	24.56	
	3.642	41.36	0.74	42.10	56.00	13.90	
	5.058	33.86	0.80	34.66	60.00	25.34	
	29.371	32.25	1.89	34.14	60.00	25.86	
	AV	0.162	46.39	0.38	46.77	55.34	8.57
		0.247	37.78	0.41	38.19	51.86	13.67
		0.505	20.70	0.52	21.22	46.00	24.78
		3.642	33.89	0.74	34.63	46.00	11.37
5.058		24.30	0.80	25.10	50.00	24.90	
29.371		30.00	1.89	31.89	50.00	18.11	
Neutral	0.162	56.05	0.32	56.37	65.34	8.97	QP
	0.242	47.04	0.34	47.38	62.04	14.66	
	0.564	30.90	0.49	31.39	56.00	24.61	
	3.720	39.91	0.69	40.60	56.00	15.40	
	7.769	33.85	0.91	34.76	60.00	25.24	
	28.302	32.50	1.91	34.41	60.00	25.59	
	AV	0.162	47.20	0.32	47.52	55.34	7.82
		0.242	38.60	0.34	38.94	52.04	13.10
		0.564	19.76	0.49	20.25	46.00	25.75
		3.720	31.40	0.69	32.09	46.00	13.91
		7.769	25.70	0.91	26.61	50.00	23.39
		28.302	29.41	1.91	31.32	50.00	18.68

TEST ENGINEER: WENCY YANG

EUT : LCD Monitor Temperature : 22°C
 Model No. : E1948SX Humidity : 48%RH
 Serial No. : E1103050-01/01 Date of Test : Mar 15, 2011
 Test Mode : D-Sub 1440*900@60Hz

Test Line	Frequency (MHz)	Meter Reading dB(μV)	Factor (dB)	Emission Level dB(μV)	Limits dB(μV)	Margin (dB)	Remark
Line	0.164	54.97	0.38	55.35	65.25	9.90	QP
	0.242	45.97	0.41	46.38	62.04	15.66	
	0.505	31.32	0.52	31.84	56.00	24.16	
	3.759	41.50	0.74	42.24	56.00	13.76	
	5.112	35.60	0.80	36.40	60.00	23.60	
	28.302	31.35	1.87	33.22	60.00	26.78	
	0.164	45.76	0.38	46.14	55.25	9.11	AV
	0.242	37.60	0.41	38.01	52.04	14.03	
	0.505	20.40	0.52	20.92	46.00	25.08	
	3.759	33.41	0.74	34.15	46.00	11.85	
	5.112	27.27	0.80	28.07	50.00	21.93	
	28.302	28.42	1.87	30.29	50.00	19.71	
Neutral	0.164	55.36	0.32	55.68	65.25	9.57	QP
	0.244	46.60	0.34	46.94	61.95	15.01	
	0.499	31.52	0.49	32.01	56.01	24.00	
	3.681	40.90	0.69	41.59	56.00	14.41	
	8.323	34.15	0.94	35.09	60.00	24.91	
	28.302	31.00	1.91	32.91	60.00	27.09	
	0.164	46.64	0.32	46.96	55.25	8.29	AV
	0.244	38.42	0.34	38.76	51.95	13.19	
	0.499	20.40	0.49	20.89	46.01	25.12	
	3.681	32.76	0.69	33.45	46.00	12.55	
	8.323	25.60	0.94	26.54	50.00	23.46	
	28.302	27.60	1.91	29.51	50.00	20.49	

TEST ENGINEER: WENCY YANG

4 RADIATED EMISSION TEST

4.1 Test Equipment

The following test equipments are used during the radiated emission test in a semi-anechoic chamber:

Item	Type	Manufacturer	Model No.	Serial No.	Last Cal.	Next Cal.
1.	Test Receiver	R&S	ESVS10	844594/001	Mar 07, 2011	Mar 07, 2012
2.	Preamplifier	Agilent	8447D	2944A10548	Sep 19, 2010	Mar 19, 2011
3.	Preamplifier	HP	8449B	3008A00864	Apr 29, 2010	Apr 29, 2011
4.	Bi-log Antenna	TESEQ	CBL6112D	23192	Dec 01, 2011	Dec 01, 2012
5.	Spectrum	Agilent	E7405A	MY45106600	May 19, 2010	May 19, 2011
6.	50Ω Coaxial Switch	Anritsu	MP59B	6200426389	Sep 19, 2010	Mar 19, 2011
7.	Software	Audix	E3	SET00200 9912M295-2	--	--

4.2 Block Diagram of Test Setup

4.2.1 EUT and Peripherals

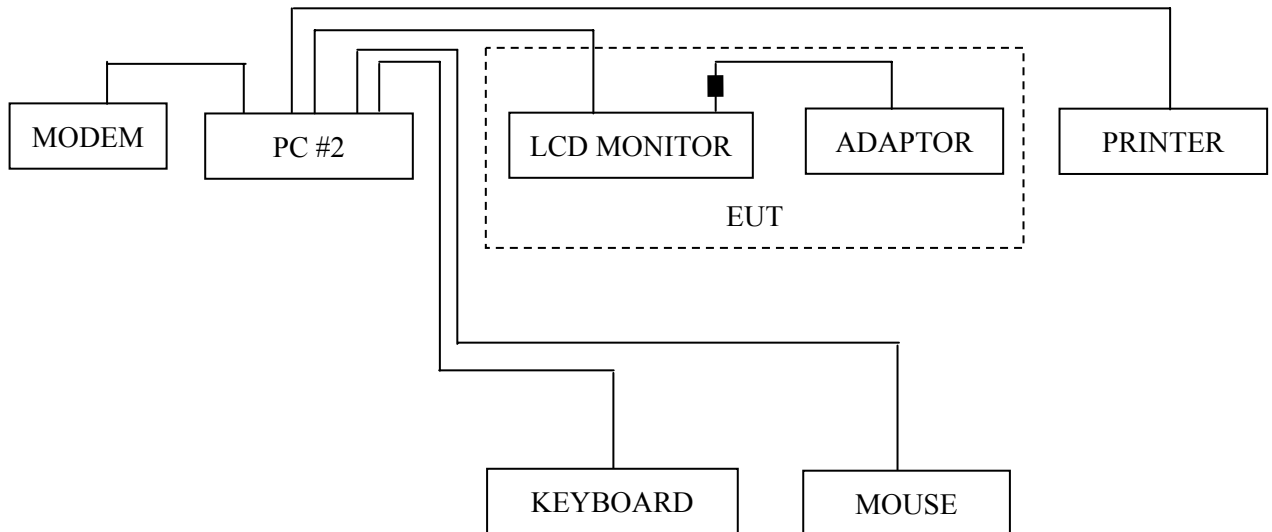

■: Ferrite core

4.2.2 Radiated emission test setup

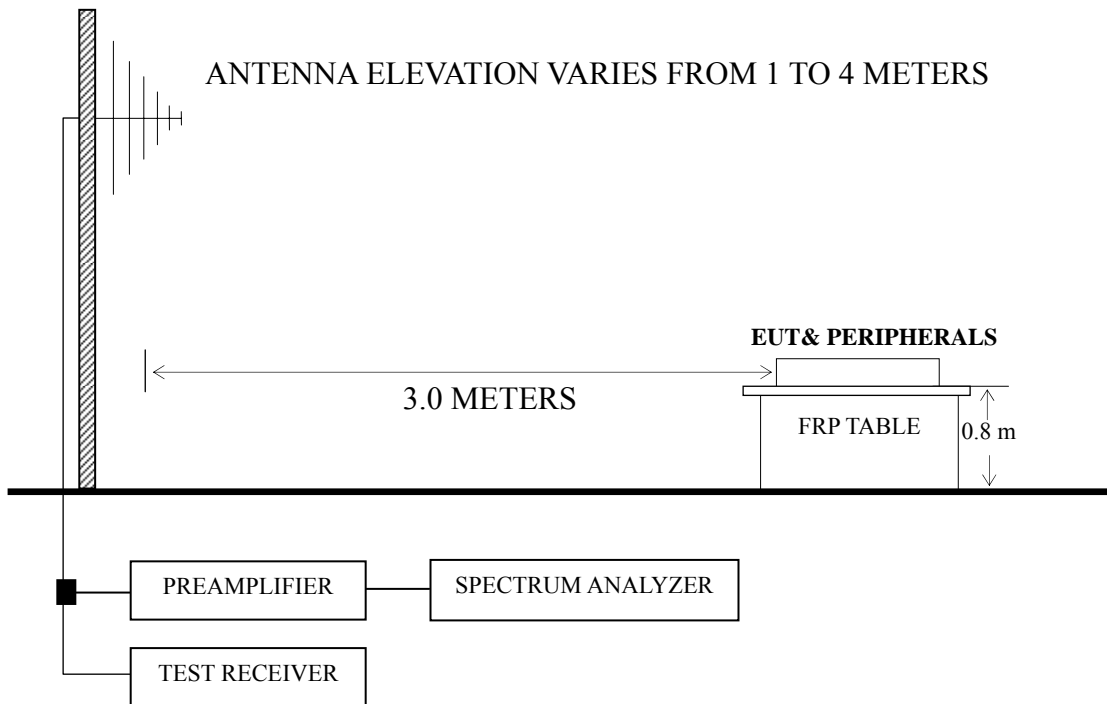

■ : 50 ohm Coaxial Switch

4.3 Radiated Emission Limit [FCC Part 15 Subpart B 15.109(a)]

Frequency (MHz)	Distance (m)	Field strength limits	
		($\mu\text{V/m}$)	dB ($\mu\text{V/m}$)
30 ~ 88	3	100	40.0
88 ~ 216	3	150	43.5
216 ~ 960	3	200	46.0
Above 960	3	500	54.0

NOTE 1 - Emission Level dB ($\mu\text{V/m}$) = 20 log Emission Level ($\mu\text{V/m}$)

NOTE 2 - The tighter limit applies at the band edges.

NOTE 3 - Distance refers to the distance in meters between the measuring instrument antenna and the closed point of any part of the device or system.

NOTE 4 - The limits shown are based on Quasi-peak value detector below or equal to 1GHz and Average value detector above 1GHz.

NOTE 5 - Above 1 GHz, the limit on peak emission is 20 dB above the maximum permitted average emission limit applicable to the EUT.

4.4 Test Configuration

The configuration of the EUT and peripherals are same as those used in conducted emission test.

Please refer to Sec.3.4.

4.5 Operating Condition of EUT

Same as conducted emission test which is listed in Sec.3.5, except for the test setup replaced by Sec.4.2.

4.6 Test Procedures

The EUT and peripherals were placed on a FRP turntable that is 0.8 meter above ground. The FRP turntable rotated 360 degrees to determine the position of the maximum emission level. The EUT was set 3 meters away from the receiving antenna, which was mounted on an antenna tower. Broadband antenna (Calibrated Bilog Antenna) was used as receiving antenna. The antenna moved up and down between 1 meter and 4 meters to find out the maximum emission level. Both horizontal and vertical polarizations of the antenna were set on measurement. In order to find the maximum emission, all of the interference cables were manipulated according to ANSI C63.4:2003 requirements during radiated emission test.

The I.F. bandwidth of Test Receiver R&S ESVS10 was set at 120 kHz below 1GHz and The Spectrum Agilent E7405A was set at 1MHz above 1GHz.

The frequency range from 30 MHz to 1000MHz was checked for all test modes.

The frequency range from 1 GHz to 2 GHz was checked for D-Sub 1280*1024@75Hz and 1440*900@60Hz modes.

The test modes were done on radiated disturbance test and all the test results are listed in Sec.4.7.

4.7 Test Results

<PASS>

The frequency and amplitude of the highest radiated emission relative the limit is reported. All the emissions not reported below are too low against the FCC limit.

Test Mode	Page
D-Sub 640*480@60Hz	P19
D-Sub 1280*1024@75Hz	P20-P21
D-Sub 1440*900@60Hz	P22-P23

NOTE 1 – **The bold test mode** listed above means the worst test mode.

NOTE 2 – Emission Level = Antenna Factor + Cable Loss + Meter Reading. (< 1GHz)

NOTE 3 – Emission Level = Antenna Factor + Cable Loss – Preamp Factor + Meter Reading. (> 1GHz)

NOTE 4 – All readings are Quasi-Peak values below or equal to 1GHz, Peak and Average values above 1GHz.

NOTE 5 – The emission levels that are 20dB below the official limit are not reported.

NOTE 6 – 0° was the table front facing the antenna. Degree is calculated from 0° clockwise facing the antenna.

NOTE 7 - The worst case is for D-Sub 1280*1024@75Hz test mode. The worst emission at horizontal polarization was detected at 30.200 MHz with corrected signal level of 15.50 dB ($\mu\text{V}/\text{m}$) (limit is 40.00dB ($\mu\text{V}/\text{m}$)), when the antenna was 1.00 m height and the turntable was at 330°. The worst emission at vertical polarization was detected at 360.000 MHz with corrected signal level of 25.70 dB ($\mu\text{V}/\text{m}$) (limit is 47.00 dB ($\mu\text{V}/\text{m}$)), when the antenna was 1.00 m height and the turntable was at 70°.

EUT : LCD Monitor Temperature : 22°C

Model No. : E1948SX Humidity : 60%RH

Serial No. : E1103050-01/01 Date of Test : Mar 16, 2011

Test Mode : D-Sub 640*480@60Hz

Polarization	Frequency (MHz)	Meter Reading dB (μV)	Antenna Factor (dB/m)	Cable Loss (dB)	Emission Level dB (μV/m)	Limits dB (μV/m)	Margin (dB)
Horizontal	95.960	11.92	10.70	1.02	23.64	40.00	16.36
	191.020	19.65	10.34	1.42	31.41	40.00	8.59
	218.180	20.87	11.52	1.51	33.90	40.00	6.10
	278.320	24.07	13.50	1.70	39.27	47.00	7.73
	364.650	23.34	15.73	1.96	41.03	47.00	5.97
	609.090	16.90	19.25	2.48	38.63	47.00	8.37
Vertical	30.100	16.09	19.53	0.63	36.25	40.00	3.75
	44.550	21.81	11.38	0.75	33.94	40.00	6.06
	85.290	19.85	8.66	0.97	29.48	40.00	10.52
	333.200	20.50	14.82	1.87	37.19	47.00	9.81
	481.050	15.92	17.68	2.22	35.82	47.00	11.18
	668.260	14.52	19.55	2.61	36.68	47.00	10.32

TEST ENGINEER: RAVEN JIN

EUT : LCD Monitor Temperature : 22°C

Model No. : E1948SX Humidity : 60%RH

Serial No. : E1103050-01/01 Date of Test : Mar 16, 2011

Test Mode : D-Sub 1280*1024@75Hz

Polarization	Frequency (MHz)	Meter Reading dB (µV)	Antenna Factor (dB/m)	Cable Loss (dB)	Preamp Factor (dB)	Emission Level dB (µV/m)	Limits dB (µV/m)	Margin (dB)	Remark
Horizontal	30.200	15.50	19.46	0.63	--	35.59	40.00	4.41	QP
	87.230	21.55	8.96	0.98	--	31.49	40.00	8.51	
	212.360	21.10	11.26	1.49	--	33.85	40.00	6.15	
	359.800	24.94	15.61	1.95	--	42.50	47.00	4.50	
	575.300	17.30	18.91	2.41	--	38.62	47.00	8.38	
	732.280	18.48	20.04	2.75	--	41.27	47.00	5.73	
	1074.000	45.61	22.16	4.50	37.26	35.01	74.00	38.99	PK
	1205.000	42.11	23.73	4.51	37.00	33.35	74.00	40.65	
	1379.000	40.15	24.87	4.54	36.58	32.98	74.00	41.02	
	1566.000	40.23	26.46	4.56	36.16	35.09	74.00	38.91	
	1647.000	39.69	26.55	4.57	36.02	34.79	74.00	39.21	
	1926.000	39.90	25.46	4.72	35.67	34.41	74.00	39.59	
	1074.000	31.61	22.16	4.50	37.26	21.01	54.00	32.99	AV
	1205.000	25.11	23.73	4.51	37.00	16.35	54.00	37.65	
	1379.000	26.15	24.87	4.54	36.58	18.98	54.00	35.02	
	1566.000	30.23	26.46	4.56	36.16	25.09	54.00	28.91	
	1647.000	29.69	26.55	4.57	36.02	24.79	54.00	29.21	
	1926.000	25.90	25.46	4.72	35.67	20.41	54.00	33.59	

TEST ENGINEER: RAVEN JIN

EUT : LCD Monitor Temperature : 22°C

Model No. : E1948SX Humidity : 60%RH

Serial No. : E1103050-01/01 Date of Test : Mar 16, 2011

Test Mode : D-Sub 1280*1024@75Hz

Polarization	Frequency (MHz)	Meter Reading dB (µV)	Antenna Factor (dB/m)	Cable Loss (dB)	Preamp Factor (dB)	Emission Level dB (µV/m)	Limits dB (µV/m)	Margin (dB)	Remark
Vertical	89.170	15.32	9.24	0.99	--	25.55	40.00	14.45	QP
	144.460	16.93	11.76	1.22	--	29.91	40.00	10.09	
	222.060	22.11	11.75	1.52	--	35.38	40.00	4.62	
	360.000	25.70	15.61	1.95	--	43.26	47.00	3.74	
	576.110	16.81	18.94	2.41	--	38.16	47.00	8.84	
	796.300	17.60	20.67	2.89	--	41.16	47.00	5.84	
	1076.000	47.25	22.16	4.50	37.26	36.65	74.00	37.35	PK
	1275.000	37.52	24.25	4.53	36.84	29.46	74.00	44.54	
	1429.000	38.39	25.49	4.54	36.45	31.97	74.00	42.03	
	1527.000	38.14	26.54	4.55	36.23	33.00	74.00	41.00	
	1692.000	37.86	26.68	4.57	35.96	33.15	74.00	40.85	
	1964.000	40.53	24.92	4.75	35.64	34.56	74.00	39.44	
	1076.000	36.25	22.16	4.50	37.26	25.65	54.00	28.35	AV
	1275.000	26.52	24.25	4.53	36.84	18.46	54.00	35.54	
	1429.000	20.39	25.49	4.54	36.45	13.97	54.00	40.03	
	1527.000	26.14	26.54	4.55	36.23	21.00	54.00	33.00	
	1692.000	29.86	26.68	4.57	35.96	25.15	54.00	28.85	
	1964.000	26.53	24.92	4.75	35.64	20.56	54.00	33.44	

TEST ENGINEER: RAVEN JIN

EUT : LCD Monitor Temperature : 22°C
 Model No. : E1948SX Humidity : 60%RH
 Serial No. : E1103050-01/01 Date of Test : Mar 16, 2011
 Test Mode : D-Sub 1440*900@60Hz

Polarization	Frequency (MHz)	Meter Reading dB (µV)	Antenna Factor (dB/m)	Cable Loss (dB)	Preamp Factor (dB)	Emission Level dB (µV/m)	Limits dB (µV/m)	Margin (dB)	Remark
Horizontal	30.100	15.10	19.53	0.63	--	35.26	40.00	4.74	QP
	85.290	22.13	8.66	0.97	--	31.76	40.00	8.24	
	132.820	15.13	12.40	1.18	--	28.71	40.00	11.29	
	216.240	19.92	11.43	1.50	--	32.85	40.00	7.15	
	360.000	23.10	15.61	1.95	--	40.66	47.00	6.34	
	576.000	21.60	18.94	2.41	--	42.95	47.00	4.05	
	1074.000	55.61	22.16	4.50	37.26	45.01	74.00	28.99	PK
	1205.000	50.11	23.73	4.51	37.00	41.35	74.00	32.65	
	1328.000	51.82	24.56	4.53	36.72	44.19	74.00	29.81	
	1467.000	49.70	26.11	4.55	36.36	44.00	74.00	30.00	
	1593.000	51.20	26.41	4.56	36.11	46.06	74.00	27.94	
	1701.000	47.71	26.70	4.57	35.94	43.04	74.00	30.96	
	1074.000	45.61	22.16	4.50	37.26	35.01	54.00	18.99	AV
	1205.000	41.11	23.73	4.51	37.00	32.35	54.00	21.65	
	1328.000	36.82	24.56	4.53	36.72	29.19	54.00	24.81	
	1467.000	38.70	26.11	4.55	36.36	33.00	54.00	21.00	
	1593.000	43.20	26.41	4.56	36.11	38.06	54.00	15.94	
	1701.000	31.71	26.70	4.57	35.94	27.04	54.00	26.96	

TEST ENGINEER: RAVEN JIN

EUT : LCD Monitor Temperature : 22°C
 Model No. : E1948SX Humidity : 60%RH
 Serial No. : E1103050-01/01 Date of Test : Mar 16, 2011
 Test Mode : D-Sub 1440*900@60Hz

Polarization	Frequency (MHz)	Meter Reading dB (µV)	Antenna Factor (dB/m)	Cable Loss (dB)	Preamp Factor (dB)	Emission Level dB (µV/m)	Limits dB (µV/m)	Margin (dB)	Remark
Vertical	144.460	17.15	11.76	1.22	--	30.13	40.00	9.87	QP
	180.350	22.93	9.90	1.38	--	34.21	40.00	5.79	
	288.020	26.28	13.71	1.73	--	41.72	47.00	5.28	
	360.000	25.10	15.61	1.95	--	42.66	47.00	4.34	
	576.110	16.25	18.94	2.41	--	37.60	47.00	9.40	
	796.300	17.19	20.67	2.89	--	40.75	47.00	6.25	
	1003.000	54.28	20.88	4.49	37.39	42.26	74.00	31.74	PK
	1148.000	51.76	23.15	4.51	37.12	42.30	74.00	31.70	
	1258.000	44.21	24.13	4.52	36.88	35.98	74.00	38.02	
	1366.000	47.87	24.80	4.54	36.62	40.59	74.00	33.41	
	1453.000	48.22	25.90	4.55	36.39	42.28	74.00	31.72	
	1593.000	48.07	26.41	4.56	36.11	42.93	74.00	31.07	
	1003.000	46.28	20.88	4.49	37.39	34.26	54.00	19.74	AV
	1148.000	35.76	23.15	4.51	37.12	26.30	54.00	27.70	
	1258.000	29.21	24.13	4.52	36.88	20.98	54.00	33.02	
	1366.000	38.87	24.80	4.54	36.62	31.59	54.00	22.41	
	1453.000	40.22	25.90	4.55	36.39	34.28	54.00	19.72	
	1593.000	34.07	26.41	4.56	36.11	28.93	54.00	25.07	

TEST ENGINEER: RAVEN JIN

5 DEVIATION TO TEST SPECIFICATIONS

None.