

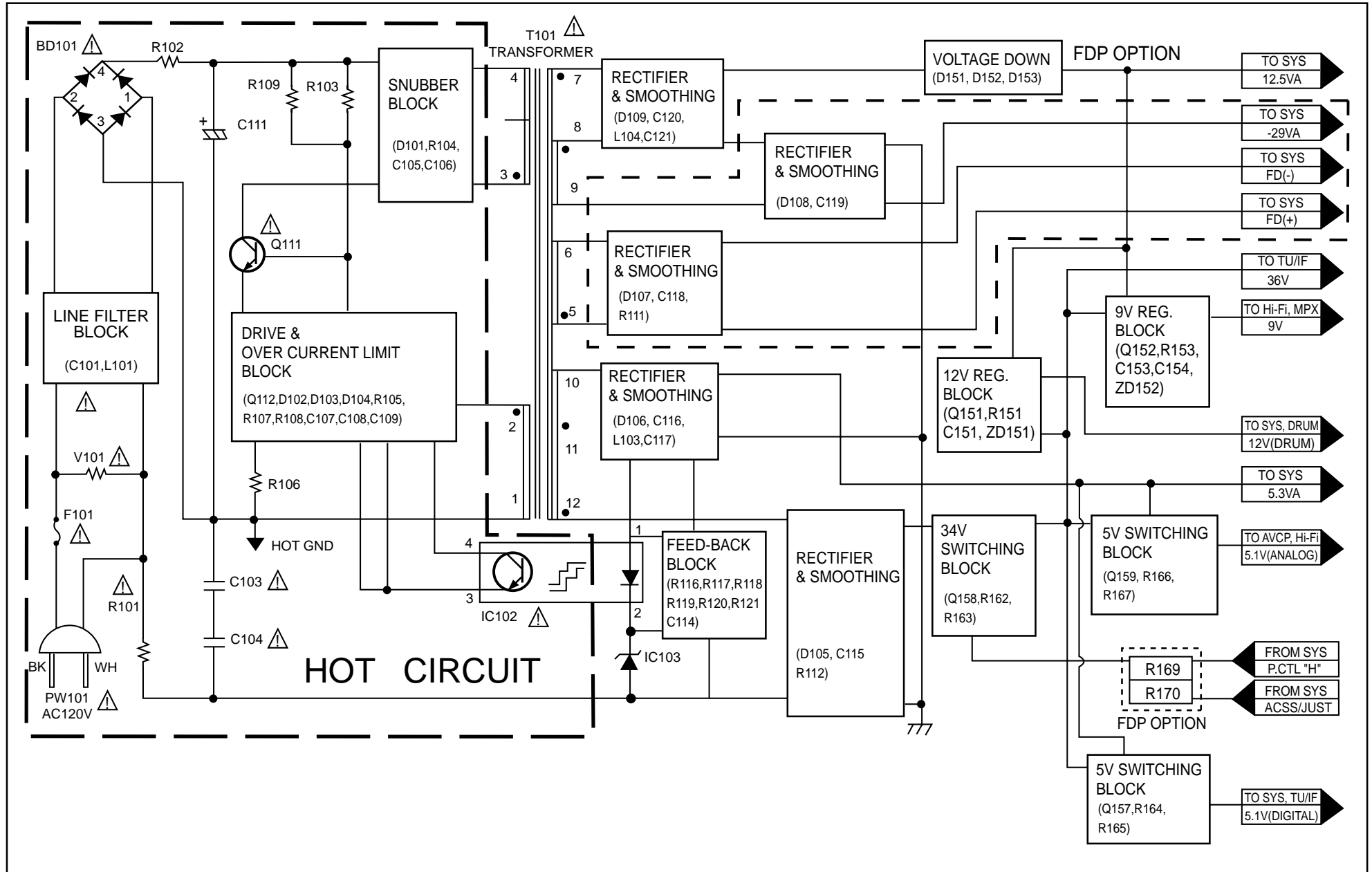

2. Power(SMPS) Block Diagram (ALGB420)



NOTES :  Symbol denotes AC ground.
 Symbol denotes DC chassis ground.

'98.10.20 R10378BA
ALGB420's

3. Tuner/IF Block Diagram (ALGB420)

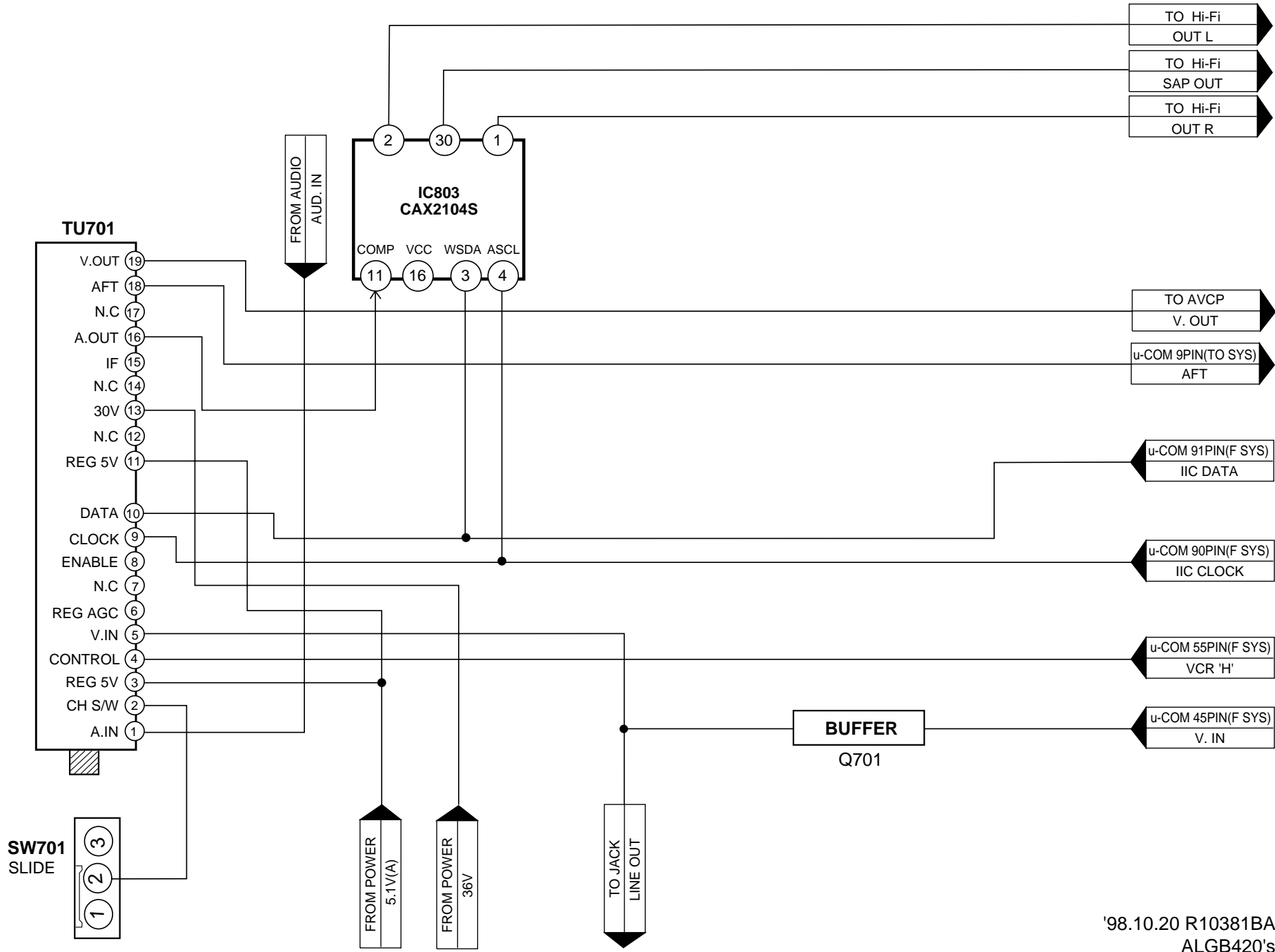

'98.10.20 R10381BA
ALGB420's

5. Normal Audio Block Diagram(ALGB420)

1) EE Mode

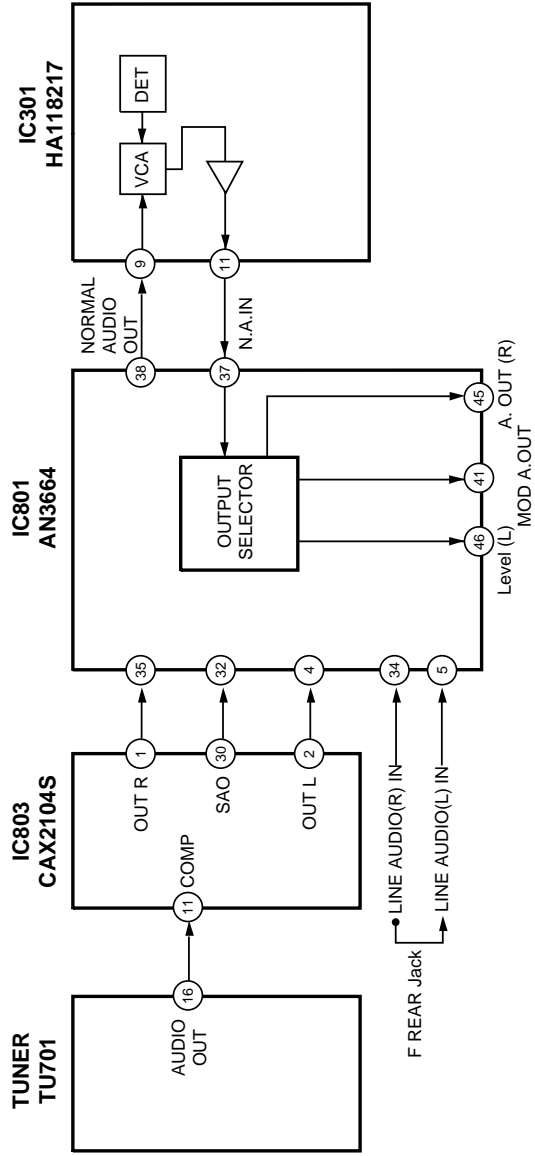

2) PB Mode

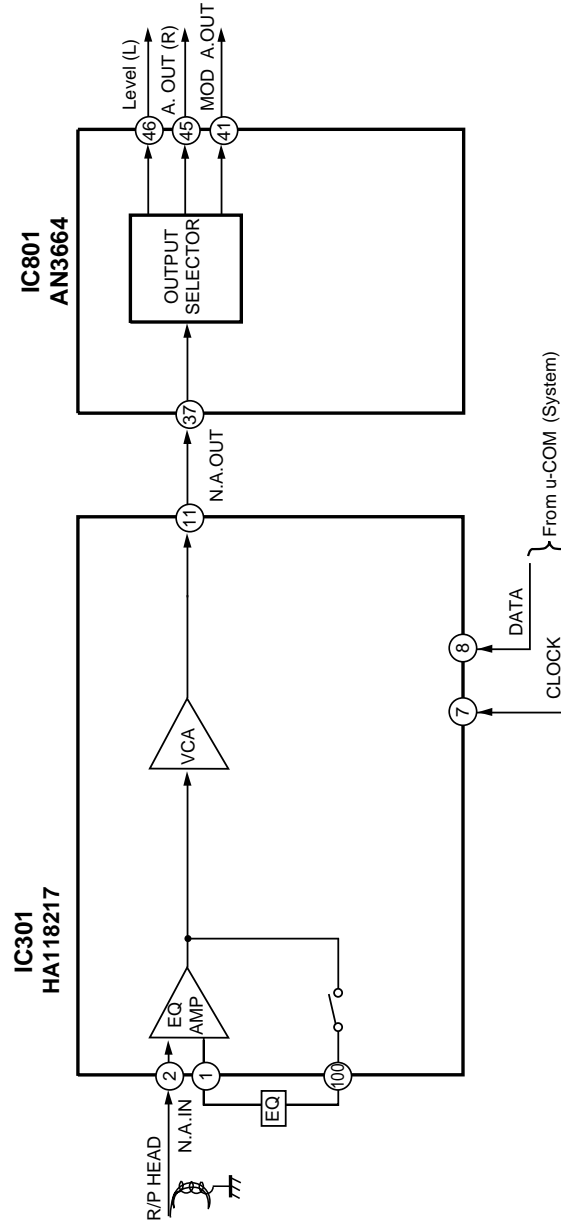

2) REC Mode

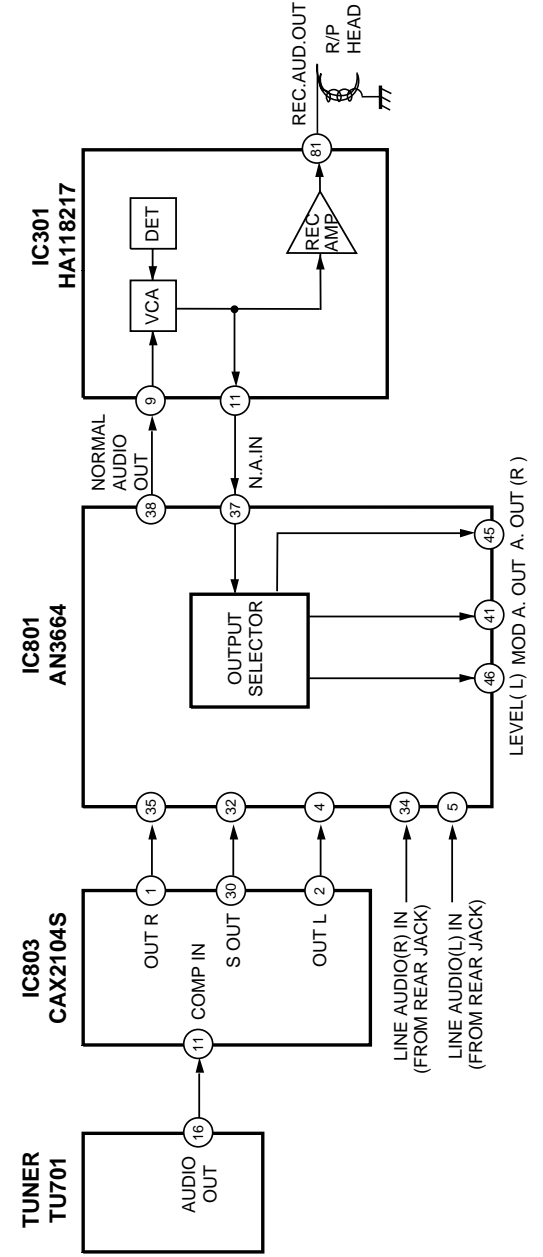

6. Hi-Fi Block Diagram (ALGB420)

1) PB MODE

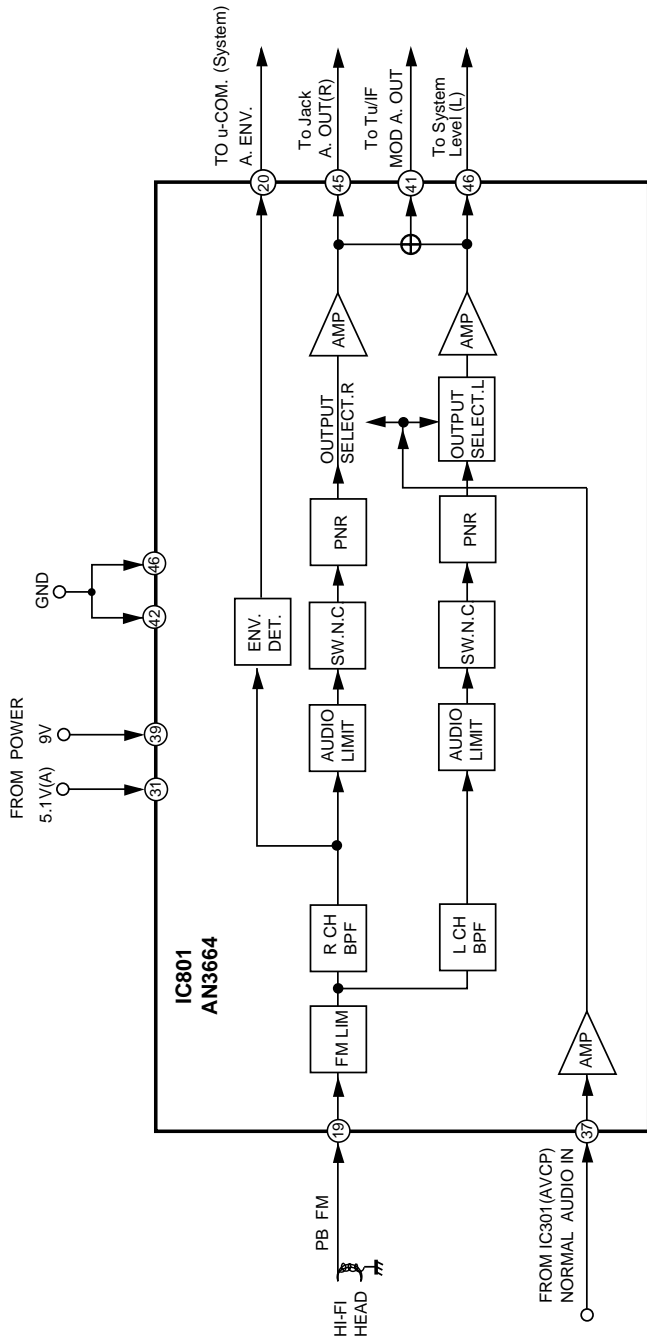

2) REC MODE

