

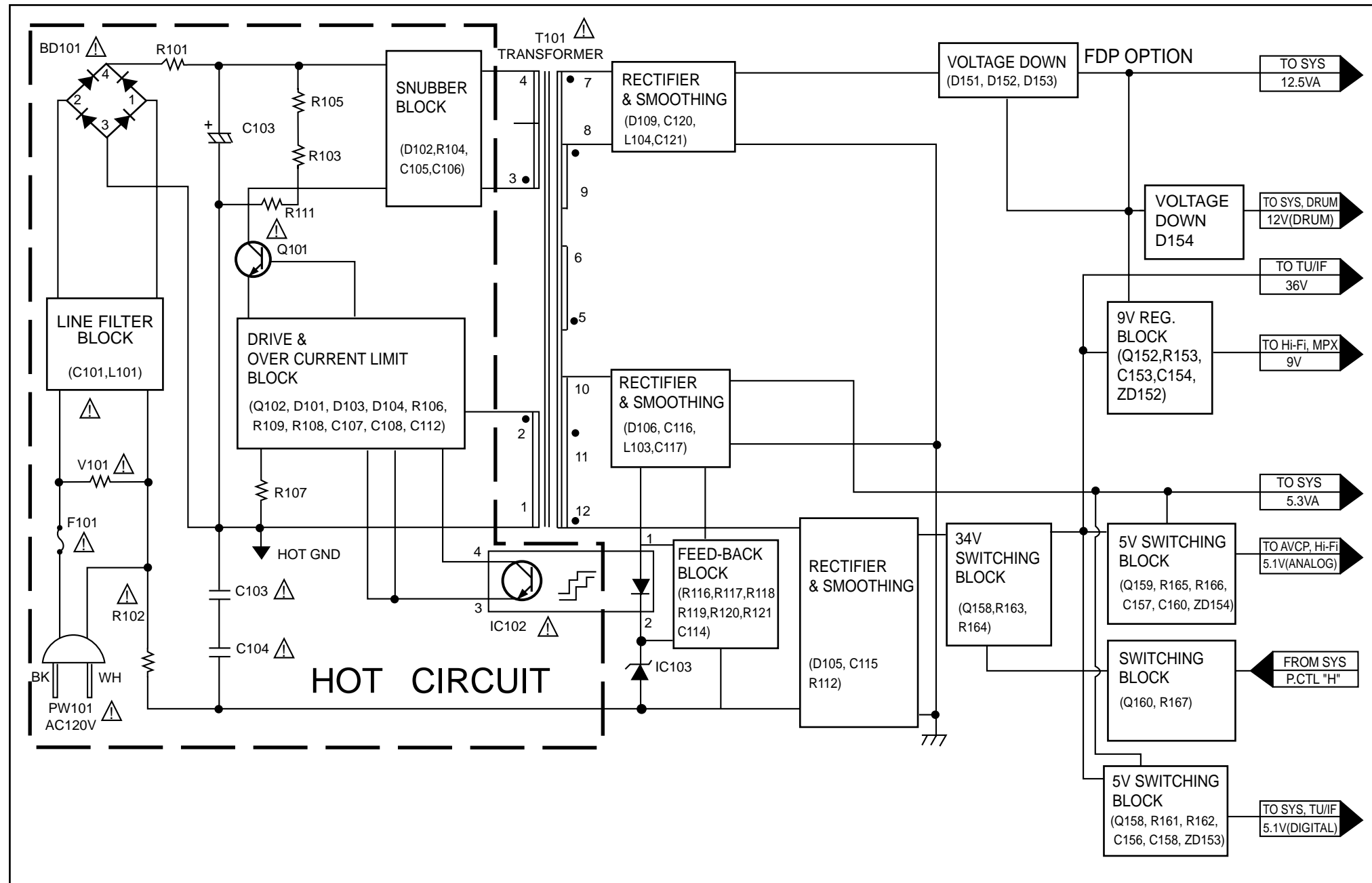

2. Power(SMPS) Block Diagram



'99.09.13 R10378BA

NOTES :  Symbol denotes AC ground.
 Symbol denotes DC chassis ground.

3. Tuner/IF Block Diagram (MONO ONLY)

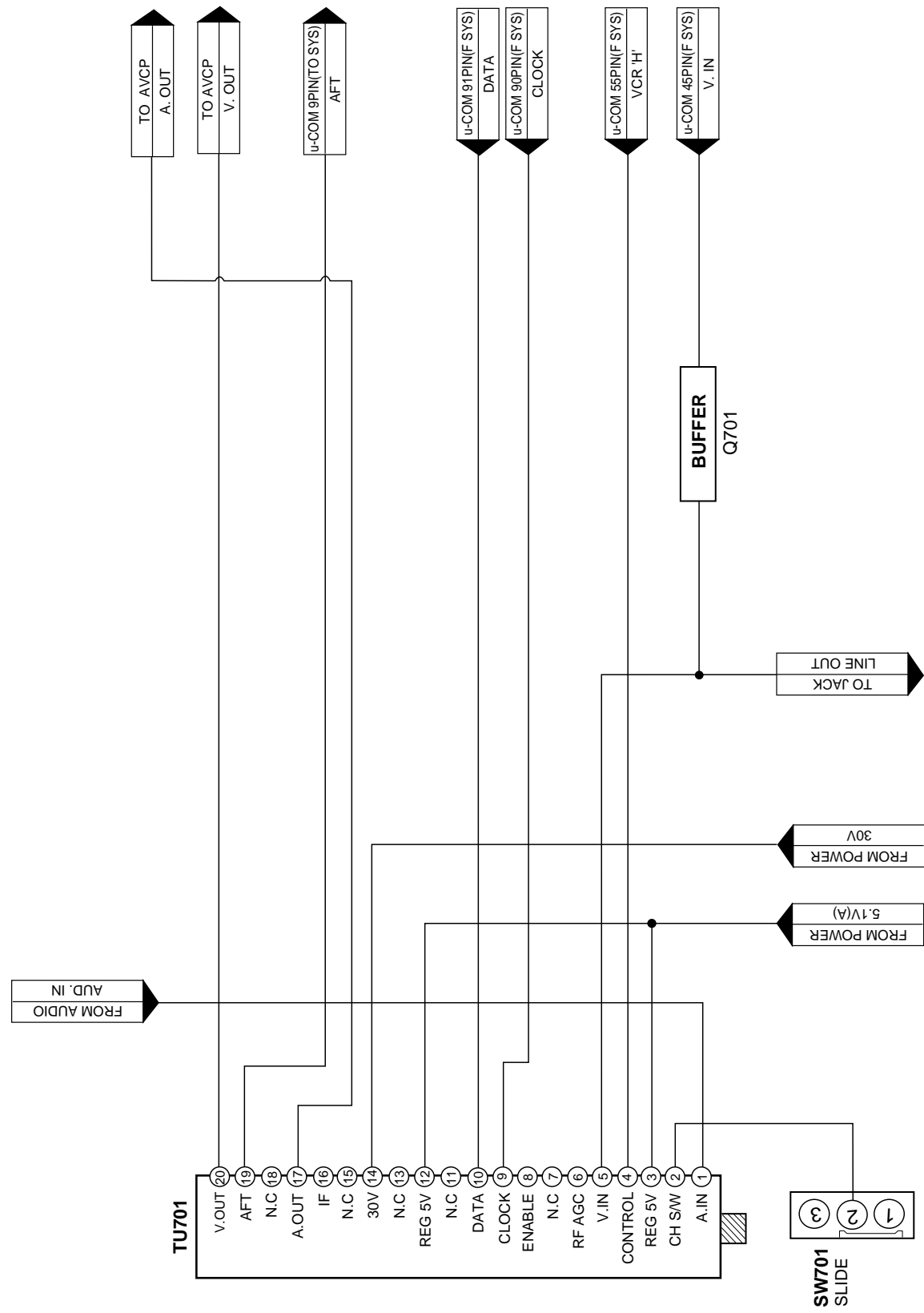

'99.09.13 R10381BA

(Hi-Fi ONLY)

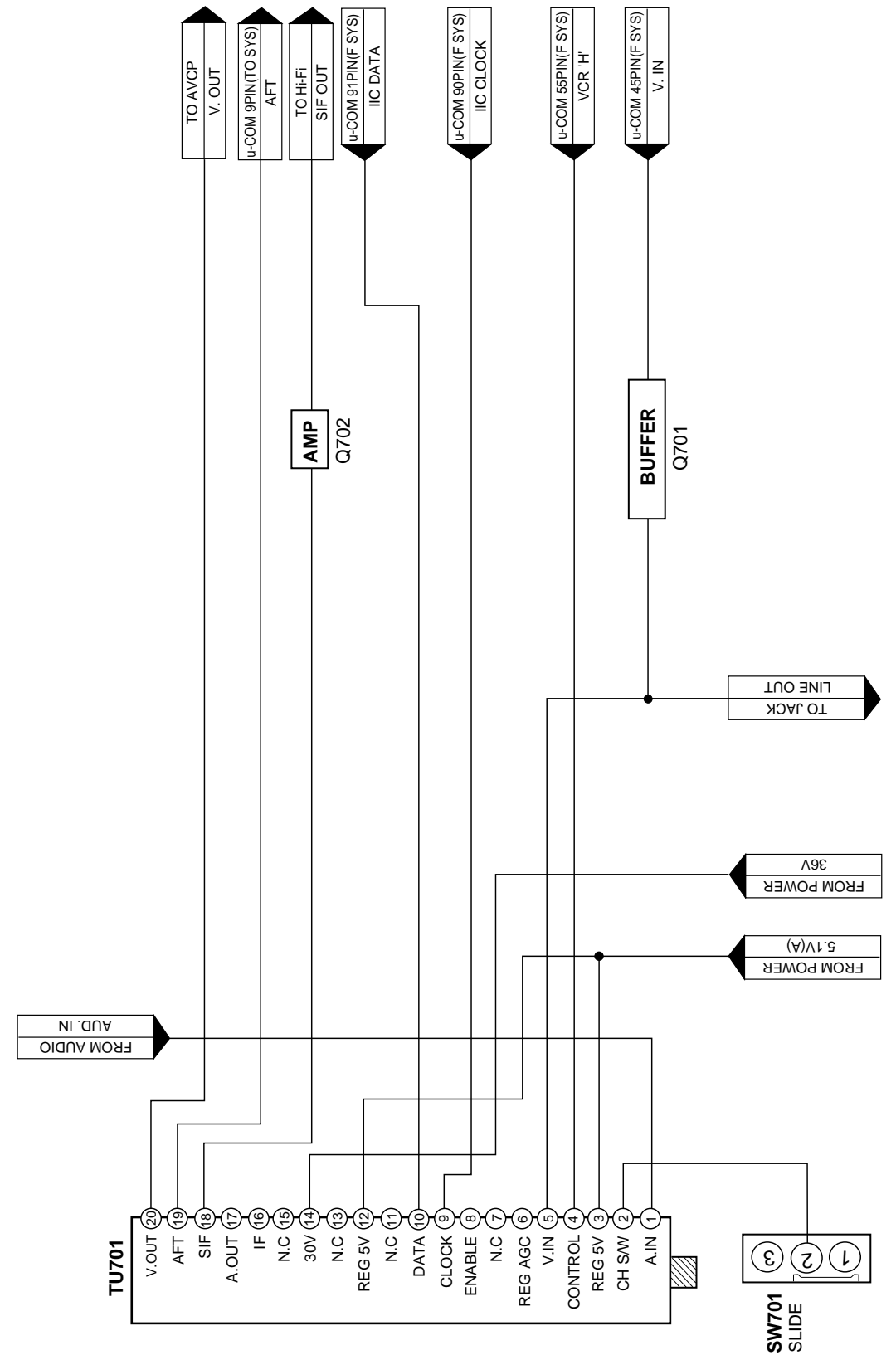

'99.09.13 R10381BA

4. AVCP Block Diagram

1) PB Mode

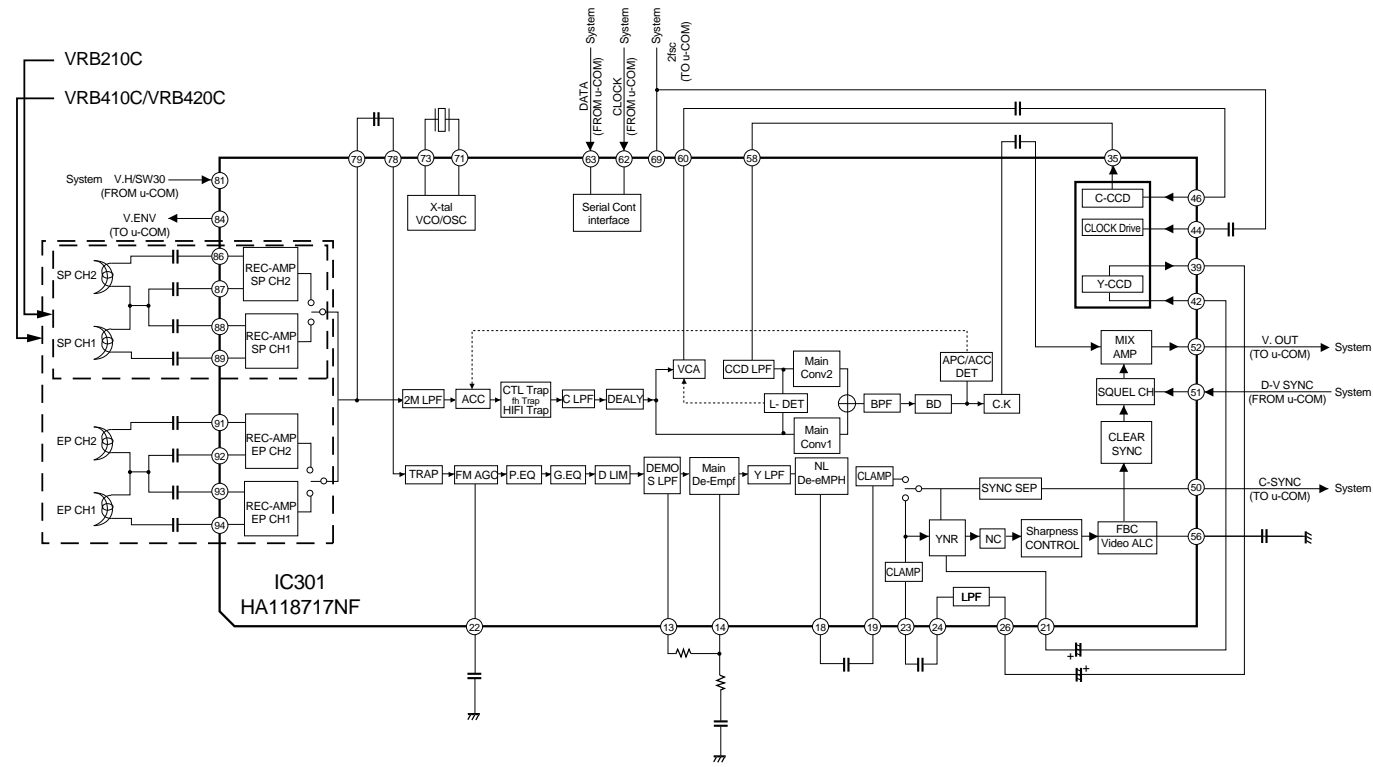

2) REC Mode

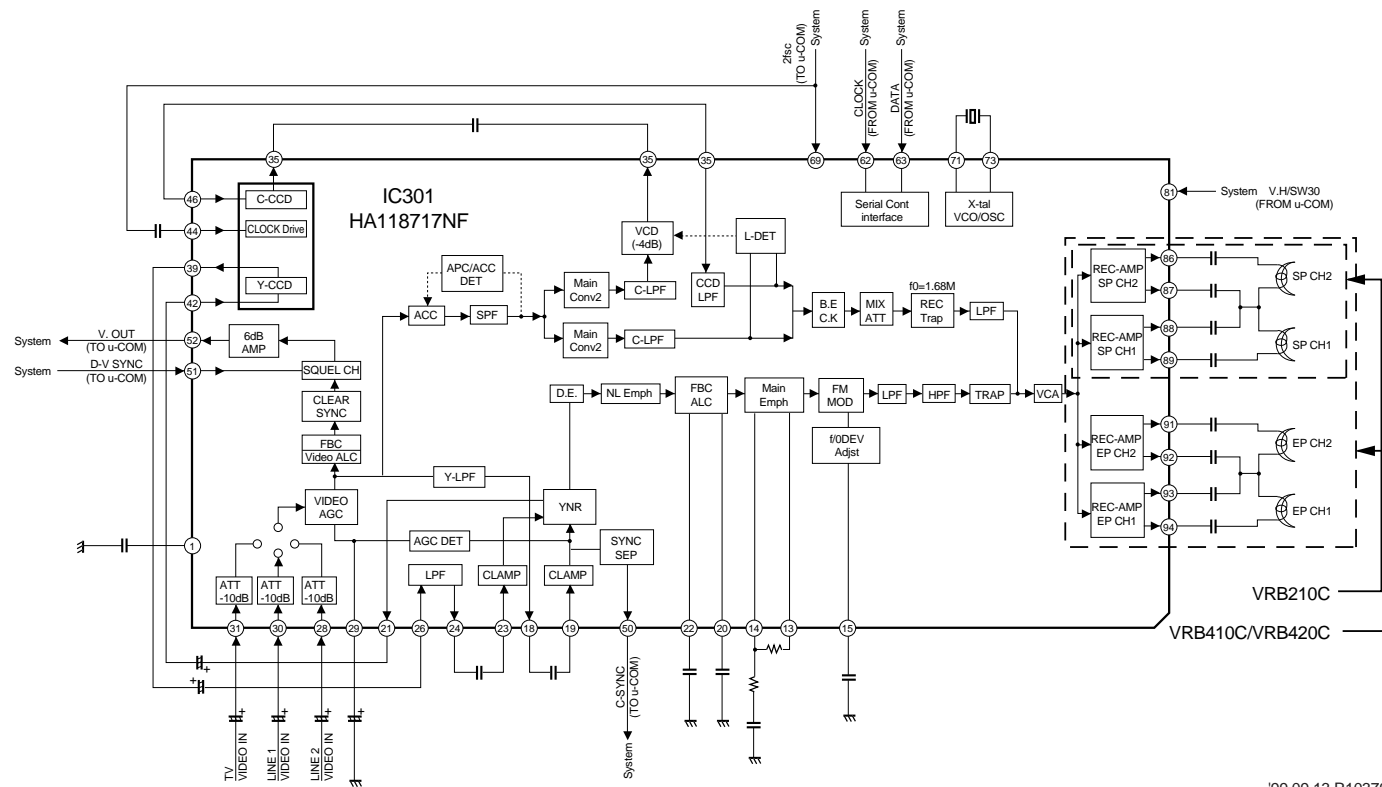

'99.09.13 R10379B/

* IC301 Waveform

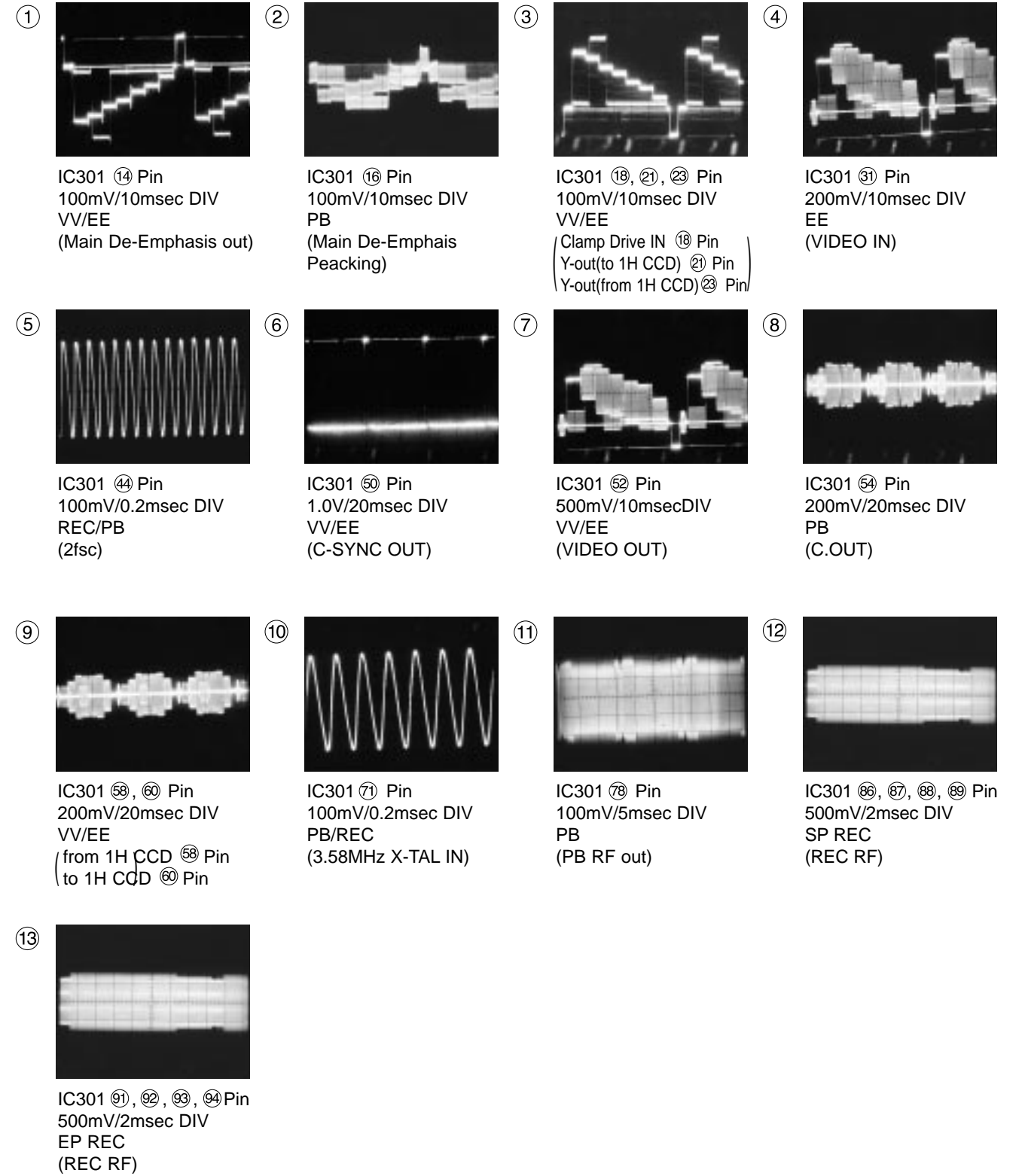

5. Audio Block Diagram (MONO ONLY)

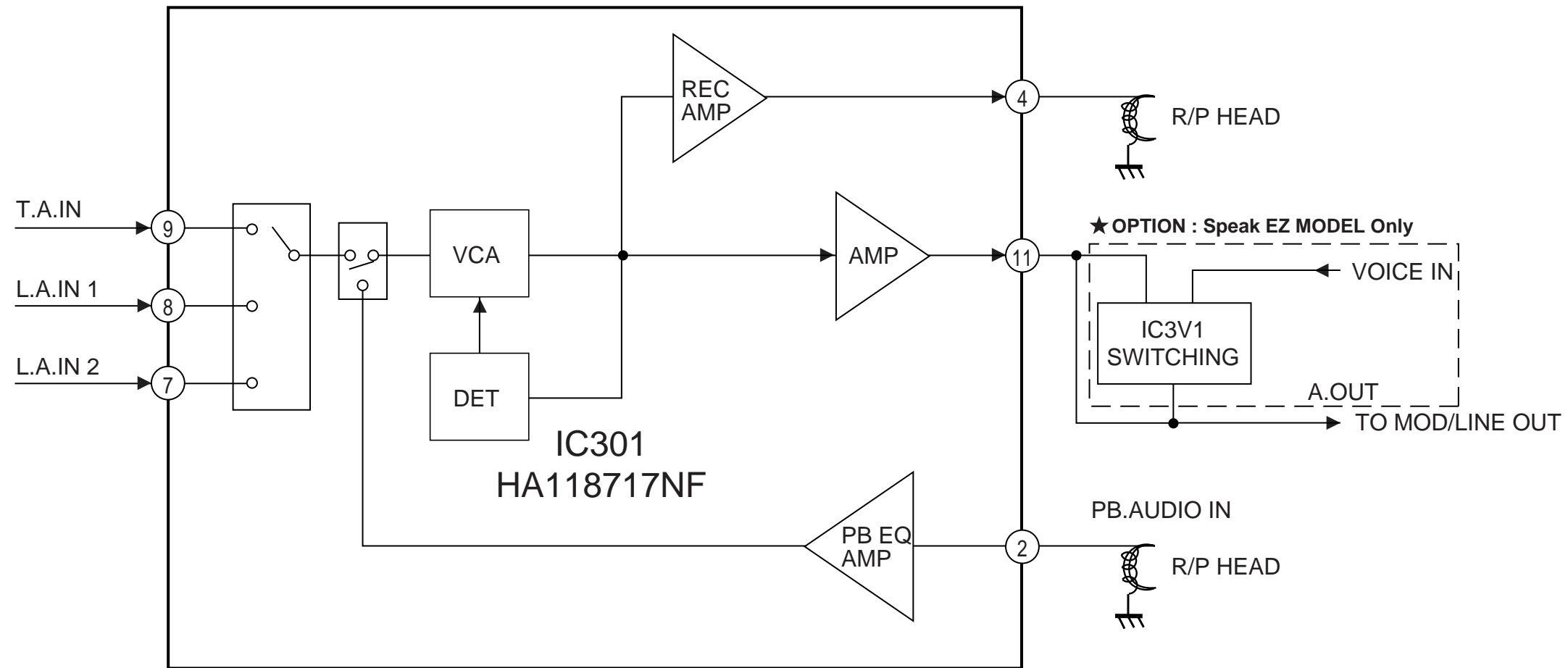

'99.09.13

5. Normal Audio Block Diagram (Hi-Fi ONLY)

1) EE Mode

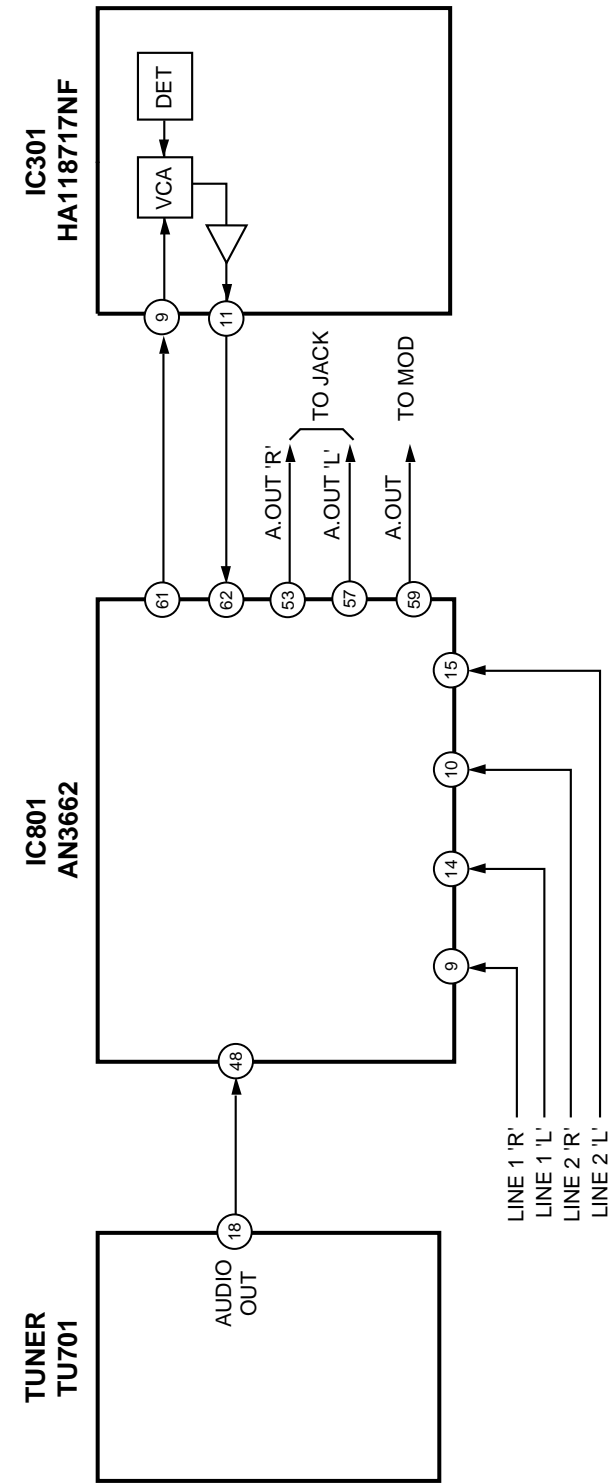

2) PB Mode

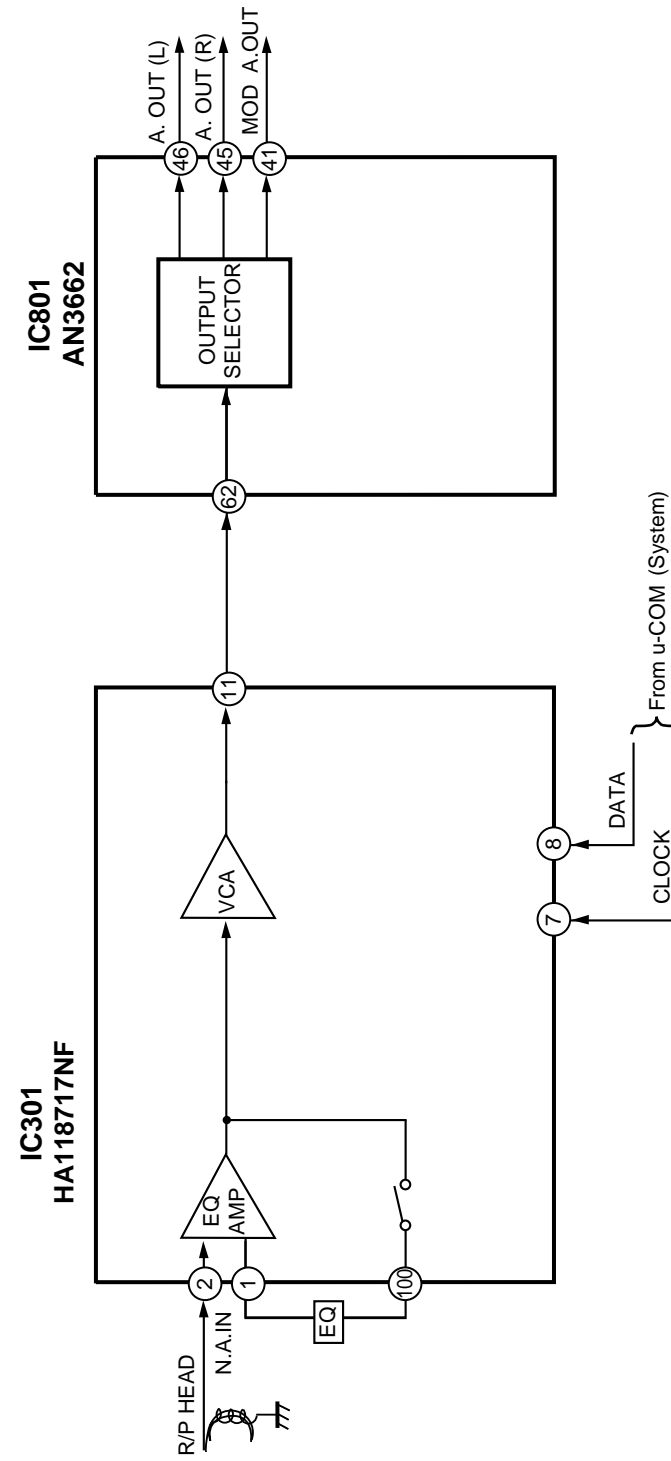

3) REC Mode

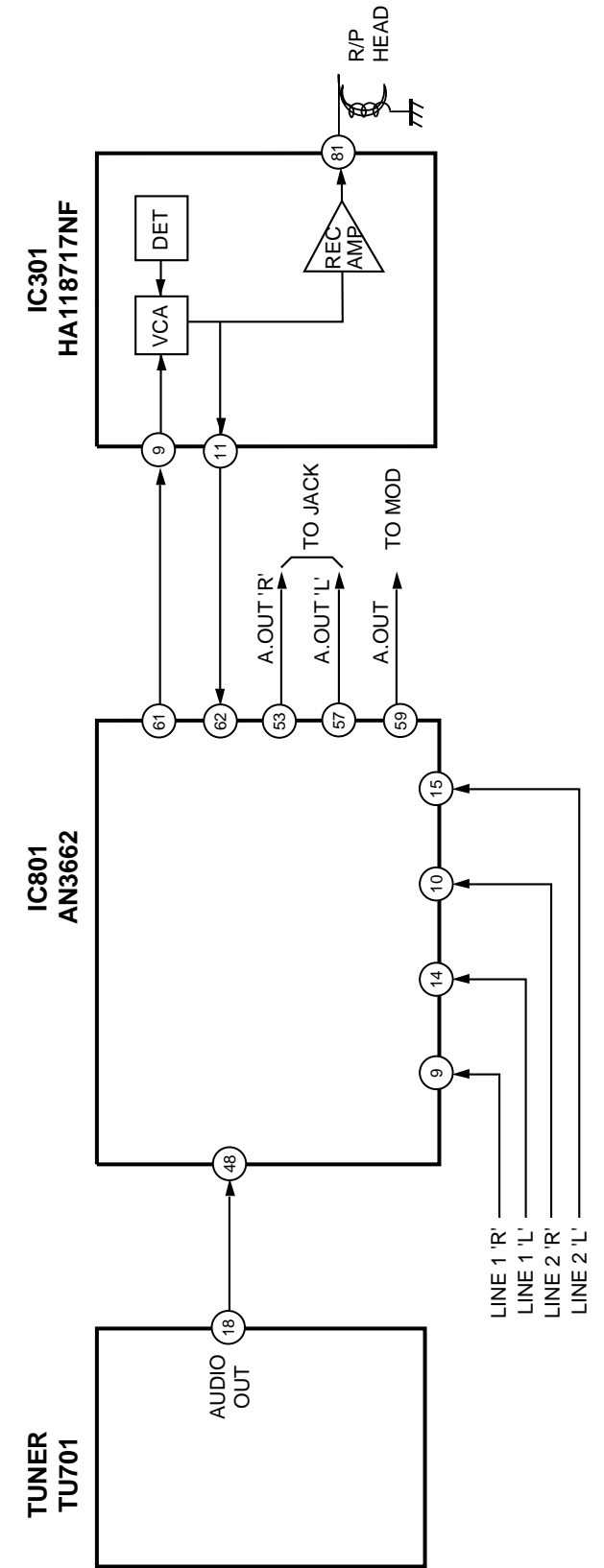

6. Hi-Fi Block Diagram (Hi-Fi ONLY)

1) PB Mode

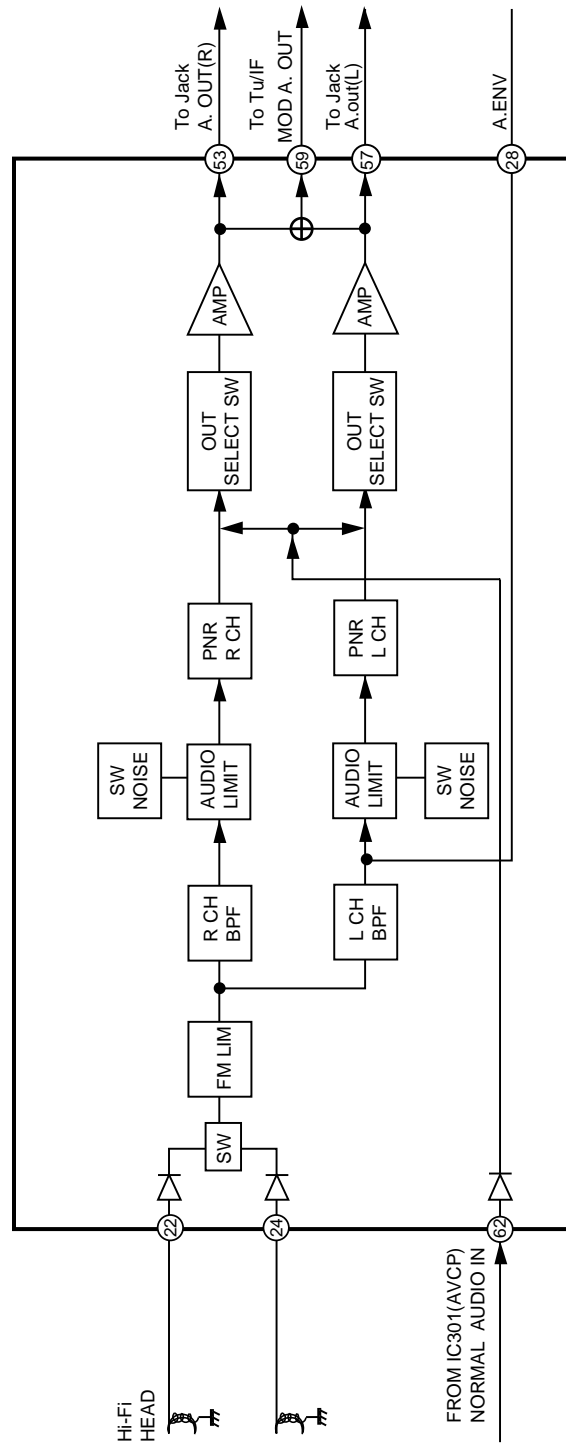

3-46

2) REC Mode

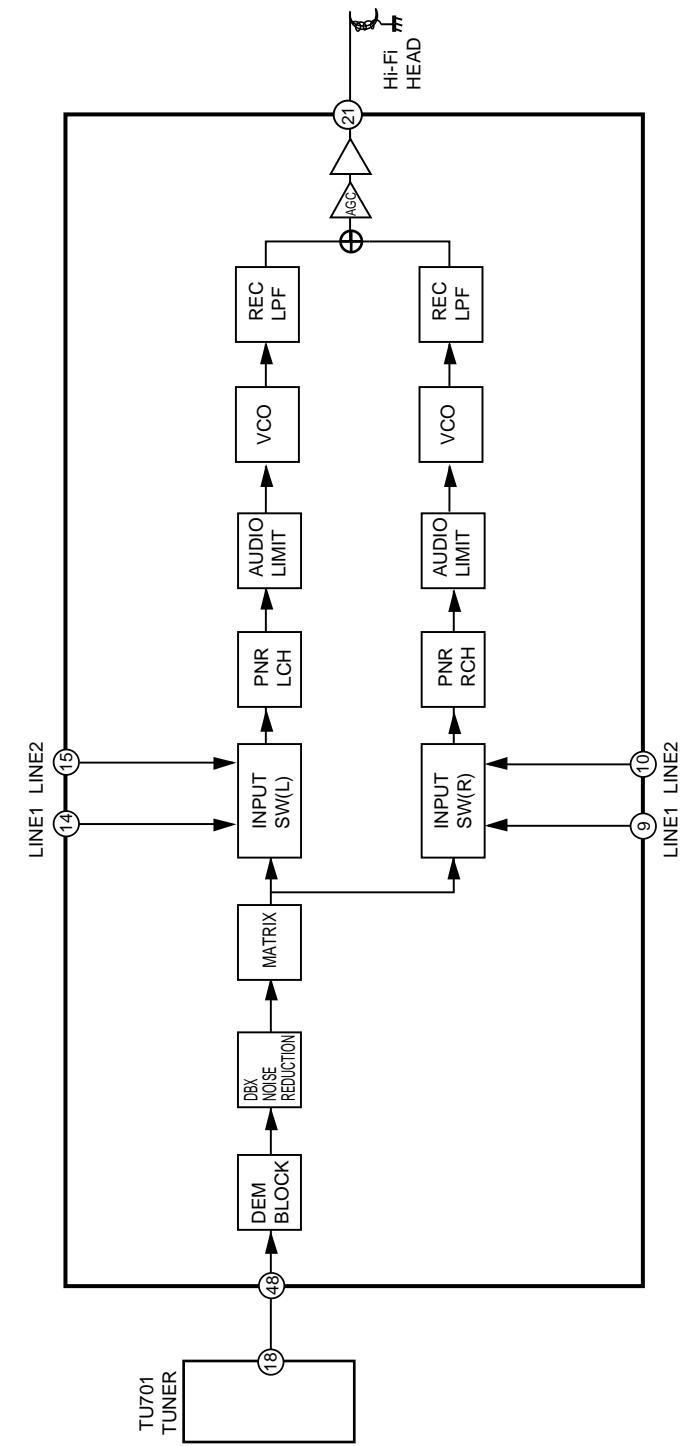

'99.09.13R10382BA

3-47

7. System Block Diagram

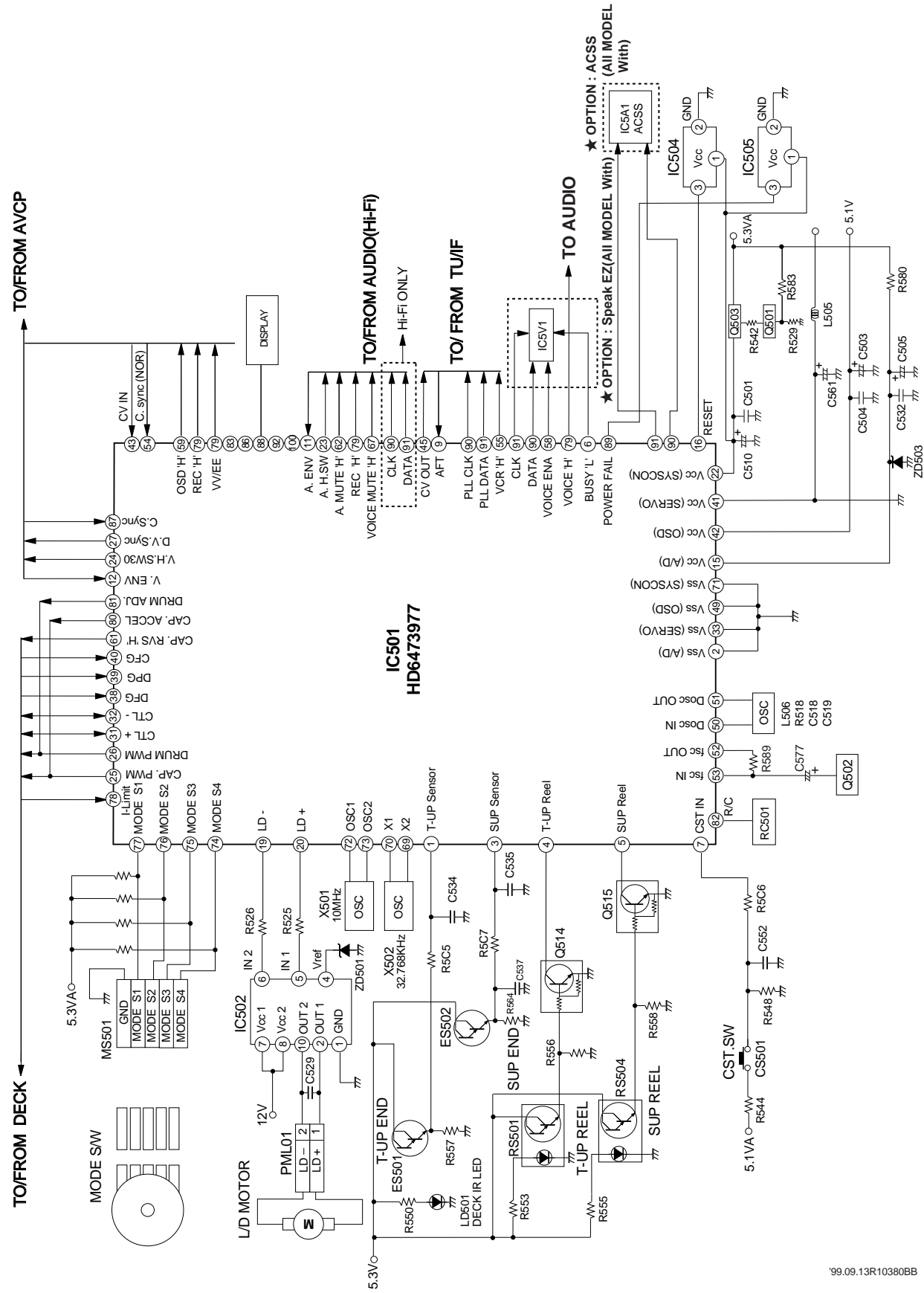

'99.09.13R10380BB

* IC501 Waveform photographs

