

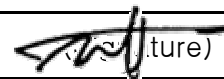

	ESTECH Co., Ltd. Rm 1015, World Venture Center II, 426-5 Gasan-dong, Guncheon-gu, Seoul, 158-803, Korea	    	Electromagnetic Interference Test Report
---	---	--	---

Test Report for FCC

Report Number		ESTF150605-001			
Applicant	Company name	LG Electronics USA			
	Address	1000 Sylvan Avenue Englewood Cliffs, NJ 07632			
	Telephone	847-941-8373			
Product	Product name	PLASMA MONITOR			
	Model No.	42PX7DCV-UA	Manufacturer	LG Electronics Inc.	
	Serial No.	NONE	Country of origin	KOREA	
Test date	2006-04-27 ~ 2006-05-04		Date of issue	4-May-06	
Testing location	ESTECH. Co., Ltd. 97-1 Hoiuk-Ri Majang-Myon, Icheon-city, KyungKi-Do, Korea				
Standard	FCC PART 15 2005 , ANSI C 63.4 2003 , ICES-003				
Test item	<input checked="" type="checkbox"/> Conducted Emission	<input type="checkbox"/> Class A	<input checked="" type="checkbox"/> Class B	Test result	OK
	<input checked="" type="checkbox"/> Radiated Emission	<input type="checkbox"/> Class A	<input checked="" type="checkbox"/> Class B	Test result	OK
Measurement facility registration number	94696				
Tested by	Engineer J.H.Kim  (Signature)				
Reviewed by	Manager Engineer J.M.Yang  (Signature)				
Abbreviation	OK, Pass = Passed, Fail = Failed, N/A = not applicable				
* Note - This test report is not permitted to copy partly without our permission - This test result is dependent on only equipment to be used - This test result based on a single evaluation of one sample of the above mentioned					

Contents

1. Laboratory Information	3
2. Description of EUT	4
3. Test Standards	5
4. Measurement condition	6
5. Measurement of radiated emission	8
5.1 Measurement equipment	8
5.2 Environmental conditions	8
5.3 Test data	9
5.4 Test data	10
6. Measurement of conducted emission	11
6.1 Measurement equipment	11
6.2 Environmental conditions	11
6.3 Test data	12
7. Photographs of test setup	13
8. Photographs of EUT	15

Appendix 1. Spectral diagram



1. Laboratory Information

1.1 General

This EUT (Equipment Under Test) has been shown to be capable of compliance with the applicable technical standards and is tested in accordance with the measurement procedures as indicated in this report. ESTECH Lab attests to accuracy of test data. All measurement reported herein were performed by ESTECH Co., Ltd.

ESTECH Lab assume full responsibility for the completeness of these measurements and vouch for the qualifications of all persons taking them.

1.2 Test Lab.

Corporation Name : ESTECH Co. Ltd

Head Office : Rm 1015, World Venture Center II, 426-5, Gasan-dong, Geumcheon-gu, Seoul, Korea
(Safety & Telecom. Test Lab)

EMC Test Lab : 58-1 Osan-Ri, GaNam-Myon, YeoJoo-Gun, KyungKi-Do, Korea
97-1 Hoiuk-Ri Majang-Myon, Icheon-city, KyungKi-Do, Korea

1.3 Official Qualification(s)

MIC : Granted Accreditation from Ministry of Information & Communication for EMC, Safety and Telecommunication

KOLAS : Accredited Lab By Korea Laboratory Accreditation Schema base on CENELEC requirements

FCC : Filed Laboratory at Federal Communications Commission

VCCI : Granted Accreditation from Voluntary Control Council for Interference from ITE

2. Description of EUT

2.1 Summary of Equipment Under Test

NONE : PLASMA MONITOR
 Model Number : 42PX7DCV-UA
 Serial Number : NONE
 Manufacturer : LG Electronics Inc.
 Country of origin : KOREA
 Rating : INPUT:AC120V / 60Hz
 Receipt Date : 2006-04-27

2.2 General descriptions of EUT

MODELS	42PX7DC (42PX7DC-UA)	42PX7DCV (42PX7DCV-UA)
Width (inches / mm)	46.7 / 1186	
Height (inches / mm)	27.6 / 654.7	
Depth (inches / mm)	25.8 / 119.5	
Weight (pounds / kg)	58.9 / 26.7	
Resolution	1024x768 (Dot)	852x480(Dot)
Power requirement	AC100-240V ~ 50/60Hz	
Television System	NTSC-M, ATSC, 64 & 256 QAM	
Program Coverage	VHF 2 ~ 13, UHF 14 ~ 69, CATV 1 ~ 135, DTV 2 ~ 69, CADTV 1 ~ 135	
External Antenna Impedance	75 Ω	
Operating Temperature Range	32 ~ 104°F (0 ~ 40°C)	
Operating Humidity Range	Less than 80%	

Resolution	Horizontal Frequency(KHz)	Vertical Frequency(Hz)	Resolution	Horizontal Frequency(KHz)	Vertical Frequency(Hz)
640x350	31.469	70.08	800x600	35.156	56.25
	31.469	59.94		37.879	60.31
640x480	37.861	72.80		48.077	72.18
	37.500	75.00		46.875	75.00
1024x768			48.363	60.00	
			56.476	70.06	
				60.023	75.02

Using Freq. : 25MHz, 4MHz, 18.43MHz,24.576MHz, 27MHz, 10MHz, 50MHz,7.3728MHz,8MHz

3. Test Standards

Test Standard : FCC PART 15 (2005) & ICES-003

This Standard sets out the regulations under which an intentional, unintentional, or incidental radiator may be operated without an individual license. It also contains the technical specifications, administrative requirements and other conditions relating to the marketing of Part 15 devices.

Test Method : ANSI C 63.4 (2003)

This standard sets forth uniform methods of measurement of radio-frequency (RF) signals and noise emitted from both unintentional and intentional emitters of RF energy in the frequency range 9 kHz to 40 GHz. Methods for the measurement of radiated and AC power-line conducted radio noise are covered and may be applied to any such equipment unless otherwise specified by individual equipment requirements. These methods cover measurement of certain devices that deliberately radiate energy, such as intentional emitters, but does not cover licensed transmitters. This standard is not intended for certification/approval of avionic equipment or for industrial, scientific, and medical (ISM) equipment. These methods apply to the measurement of individual units or systems comprised of multiple units.



ESTECH Co., Ltd.

Rm 1015, World Venture Center II,
426-5 Gasan-dong, Guncheon-gu,
Seoul, 158-803, Korea



**Electromagnetic
Interference
Test Report**

4. Measurement Condition

4.1 EUT Operation.

- * The EUT was in the following operation mode during all testing
- * The operational conditions of the EUT was determined by the manufacturer according to the typical use of the EUT with respect to the expected highest level of emission
- * After setting as test arrangement diagram, we tested the EUT under continuous displaying "H" character and playing Audio out /Video

4.2 Configuration and Peripherals

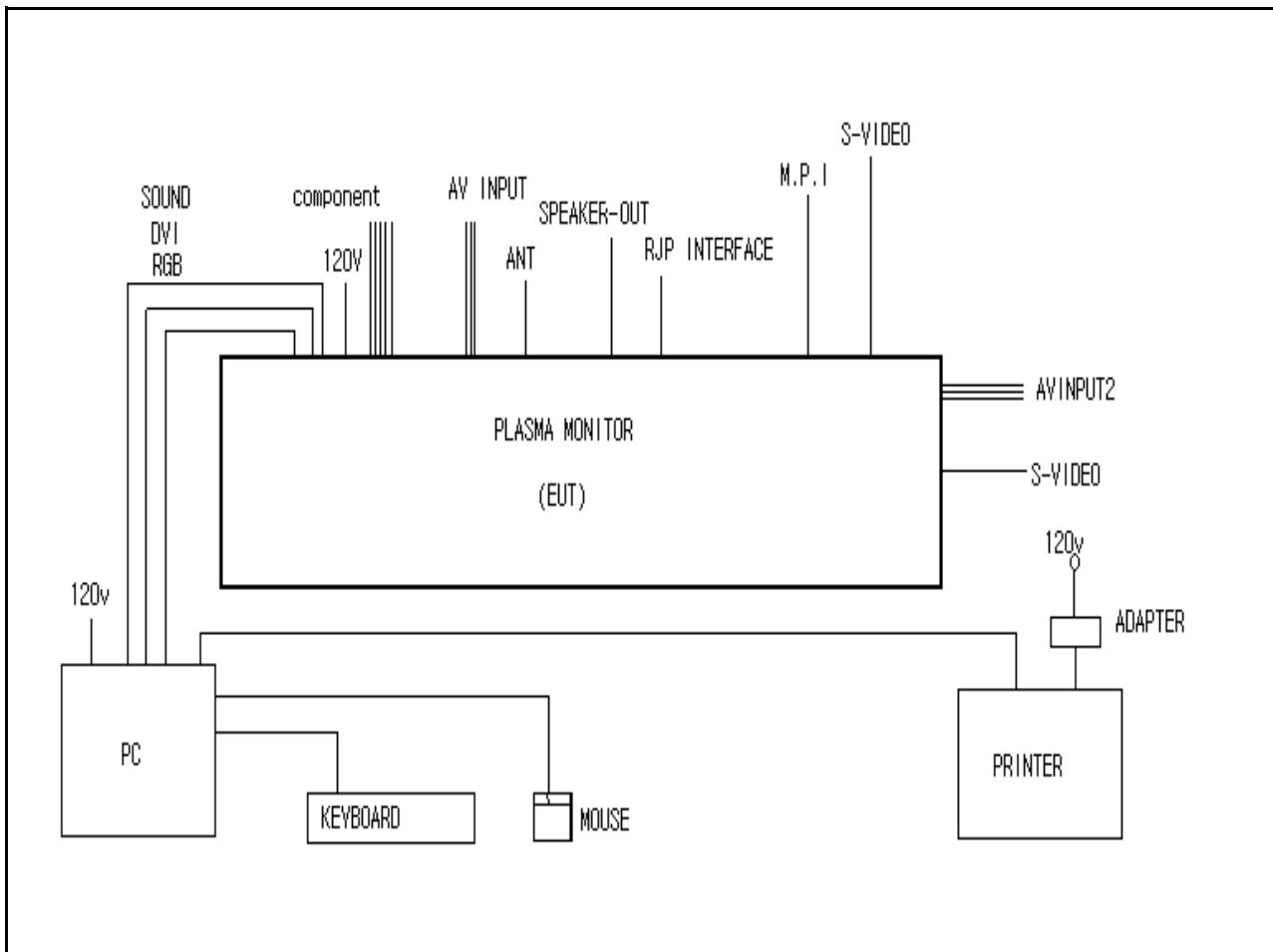

4.3 EUT and Support equipment

Equipment Name	Model Name	S/N	Manufacturer	Remark (FCC ID)
PLASMA MONITOR	42PX7DCV-UA	NONE	LG Electronics Inc.	EUT
PC	DCSM	6RDJJIS	Dell Asia Pacific sdn	-
MOUSE	M-BJ48	LZE01550574	Logitech	-
KEYBOARD	SKG-220C	TAKL217007P	monterey interantional corp	-
PRINTER	C6414J	TH18M149P2	H.P	-
ADAPTER	C6409-60152	C1H14B	Yokogawa	-

4.4 Cable Connecting

Start Equipment		End Equipment		Cable Standard		Remark
Name	I/O port	Name	I/O port	Length	Shielded	
PLASMA Monitor	RGB	PC	RGB	2	Y	-
PLASMA Monitor	DVI	PC	DVI	2	Y	-
PLASMA Monitor	SOUND-IN	PC	SOUND-OUT	2	N	-
PLASMA Monitor	COMPONENT-INPUT	-	-	2	N	-
PLASMA Monitor	AV-IN1PUT	-	-	2	N	-
PLASMA Monitor	AV-IN2PUT	-	-	2	N	-
PLASMA Monitor	S-VIDEO	-	-	2	N	-
PLASMA Monitor	S-VIDEO	-	-	2	N	-
PLASMA Monitor	RJP INTERFACE	-	-	2	N	-
PLASMA Monitor	M.P.I	-	-	2	N	-
PLASMA Monitor	ANT	-	-	2	N	-
PLASMA Monitor	SPEAKER OUT	-	-	2	N	-
PC	USB	KEYBOARD	USB	2	Y	-
PC	USB	MOUSE	USB	2	Y	-
PC	USB	PRINTER	USB	2	Y	-
PRINTER	POWER	ADAPTER	USB	2	N	-

5. Measurement of radiated disturbance

Above 30 MHz Electric Field strength was measured in accordance with FCC Part 15 (2005) & ICES-003. The test setup was made according to ANSI C 63.4 (2003) on an open test site, which allows a 3m distance measurement. The EUT was placed in the center of wooden turntable. The height of this table was 0.8m. The measurement was conducted with both horizontal and vertical antenna polarization. The turntable has fully rotated. For further description of the configuration refer to the picture of the test set-up.

5.1 Measurement equipments

Equipment Name	Type	Manufacturer	Serial No.	Next Calibration date
TEST Receiver	ESVS10	Rohde & Schwarz	838562/002	2007. 1. 23
Spectrum Analyzer	R3261C	ADVANTEST	61720116	2007. 4. 19
LogBicon Antenna	VULB 9160	S/B	3142	2006. 7. 04
Horn Antenna	BBHA 9120 D	SCHWARZBECK	352	2007. 3. 17
Turn Table	2087	EMCO	2129	-
Antenna Mast	2070-01	EMCO	9702-203	-
ANT Mast Controller	2090	EMCO	1535	-
Turn Table Controller	2090	EMCO	1535	-

5.2 Environmental Condition

Test Place : Open site(3m)
 Temperature (°C) : 20 °C
 Humidity (%) : 41 %



ESTECH Co., Ltd.

Rm 1015, World Venture Center II,
426-5 Gasan-dong, Guncheon-gu,
Seoul, 158-803, Korea



**Electromagnetic
Interference
Test Report**

5.3 Test data

Test Date : 2-May-06

Measurement Distance : 3 m

Frequency (MHz)	Reading (dB μ V)	Position (V/H)	Height (m)	Correction Factor		Result Value		
				Ant Factor (dB)	Cable (dB)	Limit (dB μ V/m)	Result (dB μ V/m)	Margin (dB)
52.50	21.90	H	2.7	12.59	1.0	40.0	35.54	-4.46
76.16	15.70	H	2.6	9.89	1.3	40.0	26.88	-13.12
111.55	17.90	H	1.9	11.09	1.6	43.5	30.60	-12.90
131.26	18.30	H	1.8	12.64	1.7	43.5	32.65	-10.85
153.08	7.90	H	1.7	13.92	1.9	43.5	23.72	-19.78
190.81	16.70	H	1.5	11.12	2.2	43.5	30.00	-13.50
205.89	22.10	V	1.0	10.52	2.2	43.5	34.83	-8.67
236.25	18.10	H	1.2	11.38	2.4	46.0	31.86	-14.14
266.68	26.10	H	1.2	12.28	2.5	46.0	40.86	-5.14
304.83	10.60	H	1.2	13.29	2.7	46.0	26.61	-19.39
315.01	15.70	H	1.1	13.51	2.8	46.0	31.97	-14.03
341.24	10.10	H	1.0	14.12	2.8	46.0	27.05	-18.95
349.92	11.30	H	1.0	14.30	2.9	46.0	28.47	-17.53
405.00	19.30	V	1.0	15.43	3.2	46.0	37.90	-8.10
551.26	9.90	H	1.0	17.96	3.7	46.0	31.56	-14.44
600.01	12.90	V	1.0	19.16	4.0	46.0	36.01	-9.99
755.98	12.70	H	1.0	21.32	4.4	46.0	38.45	-7.55
809.98	11.20	H	1.0	21.83	4.7	46.0	37.74	-8.26
Remark	H : Horizontal, V : Vertical TEST MODE ; Resolution 1024 * 768 (75Hz) at RGB mode (Worse Case)							

5.4 Test data

Test Date : 2-May-06

Measurement Distance : 3 m

Frequency (MHz)	Reading (dB μ V)	Position (V/H)	Height (m)	Correction Factor		Result Value		
				Ant Factor (dB)	Cable (dB)	Limit (dB μ V/m)	Result (dB μ V/m)	Margin (dB)
52.51	21.00	H	2.6	12.59	1.0	40.0	34.64	-5.36
78.75	20.50	H	2.4	9.94	1.3	40.0	31.74	-8.26
131.24	12.60	H	1.9	12.64	1.7	43.5	26.95	-16.55
149.82	13.90	H	1.6	13.45	1.9	43.5	29.25	-14.25
198.13	18.10	H	1.4	11.27	2.2	43.5	31.58	-11.92
205.02	22.00	V	1.0	10.50	2.2	43.5	34.70	-8.80
236.88	18.10	H	1.2	11.40	2.4	46.0	31.88	-14.12
266.67	26.20	H	1.2	12.28	2.5	46.0	40.96	-5.04
300.01	14.70	H	1.2	13.19	2.7	46.0	30.59	-15.41
315.00	17.80	H	1.2	13.51	2.8	46.0	34.07	-11.93
350.01	12.20	H	1.1	14.30	2.9	46.0	29.38	-16.62
400.00	14.90	H	1.0	15.32	3.2	46.0	33.37	-12.63
405.03	20.10	H	1.0	15.43	3.2	46.0	38.70	-7.30
479.96	15.20	V	1.0	16.89	3.5	46.0	35.57	-10.43
600.01	12.30	V	1.0	19.16	4.0	46.0	35.41	-10.59
756.03	11.20	H	1.0	21.32	4.4	46.0	36.95	-9.05
809.98	11.70	H	1.0	21.83	4.7	46.0	38.24	-7.76
Remark	H : Horizontal, V : Vertical TEST MODE ; Resolution 1024 * 768 (75Hz) at DVI mode (Worse Case)							

6. Measurement of conducted disturbance

The continuous disturbance voltage of AC Mains in the frequency from 0.15 to 30 MHz was measured in accordance to FCC Part 15 (2005) & ICES-003. The test setup was made according to ANSI C 63.4 (2003) in a shielded. The EUT was placed on a non-conductive table at least 80 above the ground plan. A grounded vertical reference plane was positioned in a distance of 40cm from the EUT. The distance from the EUT to other metal surfaces was at least 0.8m. The EUT was only earthen by its power cord through the line impedance stabilizing network. The power cord has been bundled to a length of 1.0m.. The test receiver with Quasi Peak detector complies with CISPR 16.

6.1 Measurement equipments

Equipment Name	Type	Manufacturer	Serial No.	Next Calibration date
LISN	ESH3-Z5	Rohde & Schwarz	838979/010	2007. 2. 27
LISN	NNLA8120A	Schwarzbeck	NONE	2007. 2. 27
TEST Receiver	ESPI7	Rohde & Schwarz	100185	2006. 8. 22
Pulse Limiter	ESH3Z2	Rohde & Schwarz	NONE	2006. 6. 15

6.2 Environmental Condition

Test Place : Shield Room
 Temperature (°C) : 19 °C
 Humidity (%) : 44 %



ESTECH Co., Ltd.

Rm 1015, World Venture Center 11,
426-5 Gasan-dong, Guncheon-gu,
Seoul, 158-803, Korea



**Electromagnetic
Interference
Test Report**

7. Photographs of test setup

7.1 Setup for Radiated Test : 30 ~ 1000 MHz

[Front]



[Rear]





ESTECH Co., Ltd.

Rm 1015, World Venture Center II,
426-5 Gasan-dong, Guncheon-gu,
Seoul, 158-803, Korea



**Electromagnetic
Interference
Test Report**

7.2 Setup for Conducted Test : 0.15 ~ 30 MHz

[Front]



[Rear]

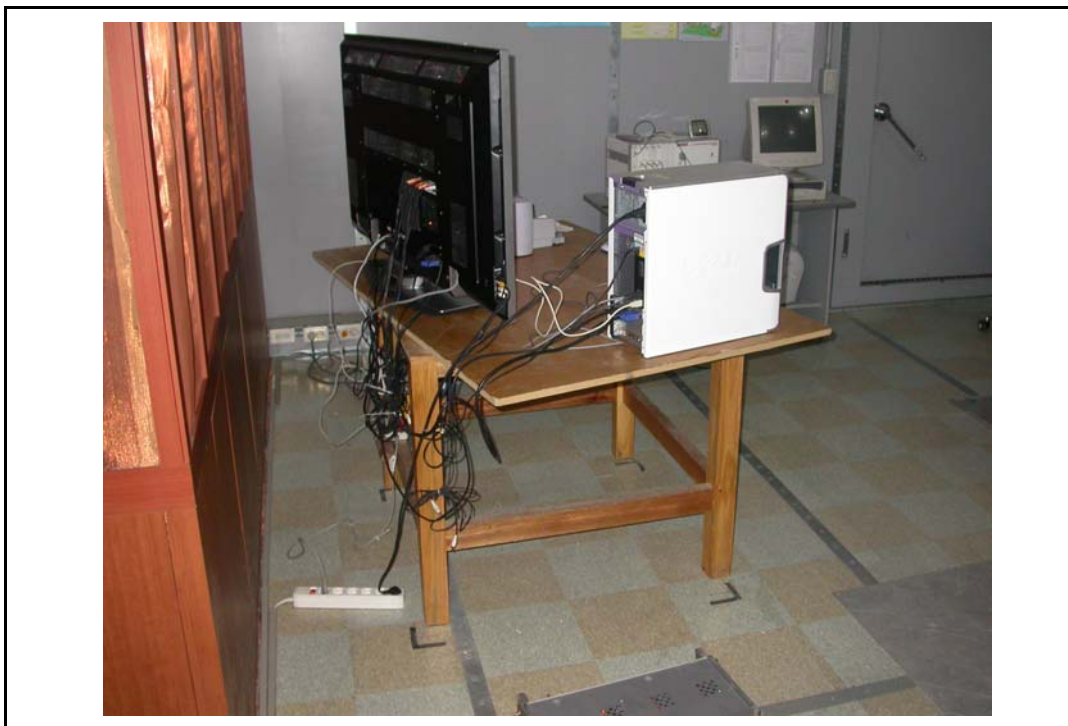



ESTECH Co., Ltd.

Rm 1015, World Venture Center II,
426-5 Gasan-dong, Guncheon-gu,
Seoul, 158-803, Korea



**Electromagnetic
Interference
Test Report**

8. Photographs of EUT

[Front]

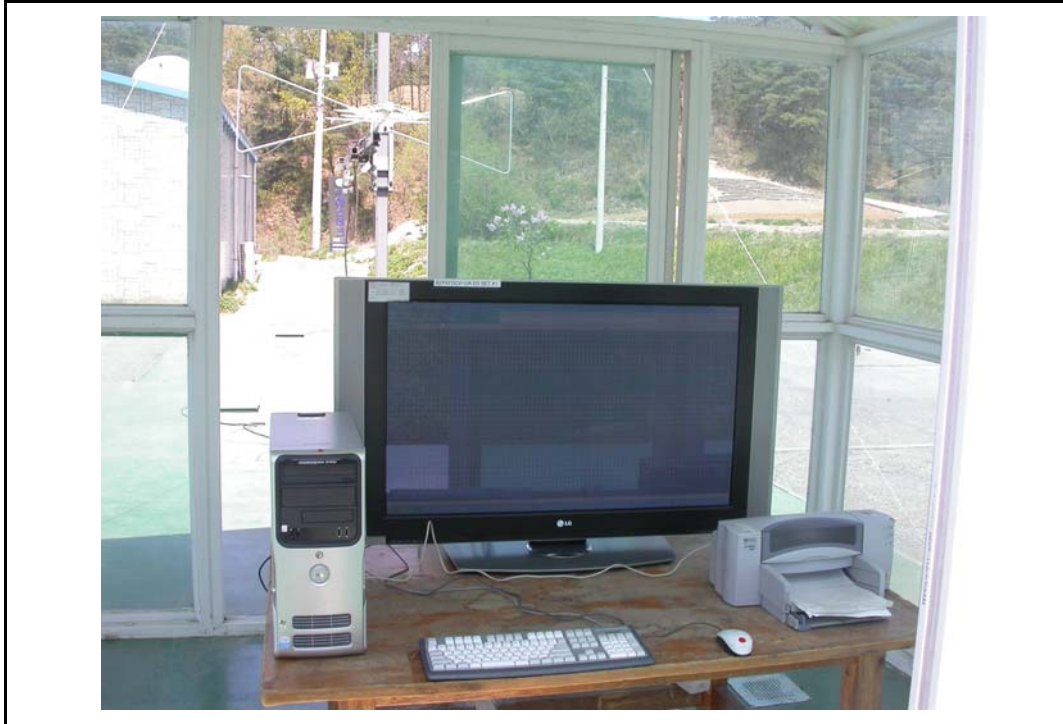

[Rear]



Appendix 1. Spectral diagram

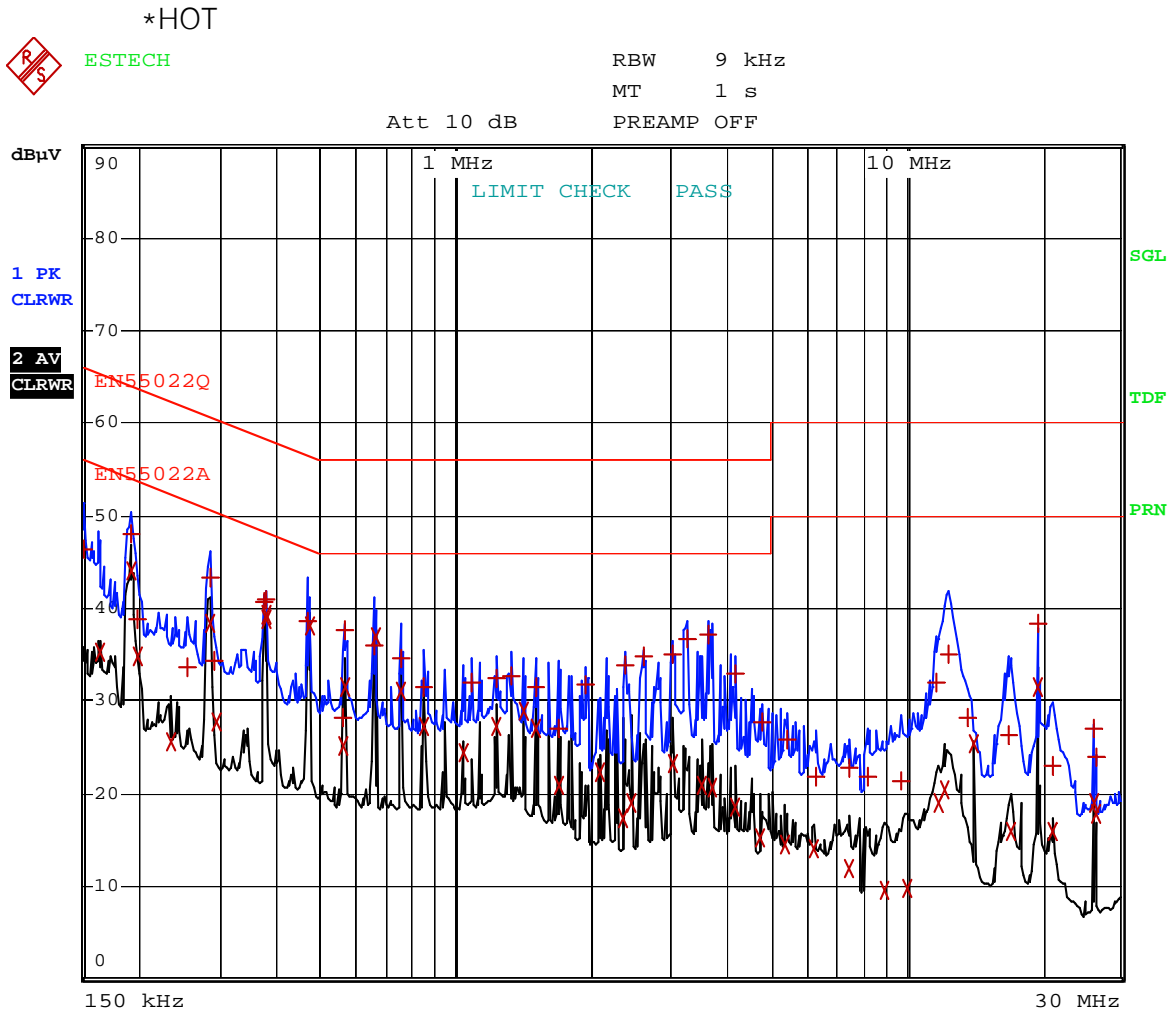

Comment: 42PX7DCV-UA RGB HOT
Date: 27.APR.2006 18:14:23

*NEUTRAL



ESTECH

RBW 9 kHz

MT 1 s

Att 10 dB

PREAMP OFF

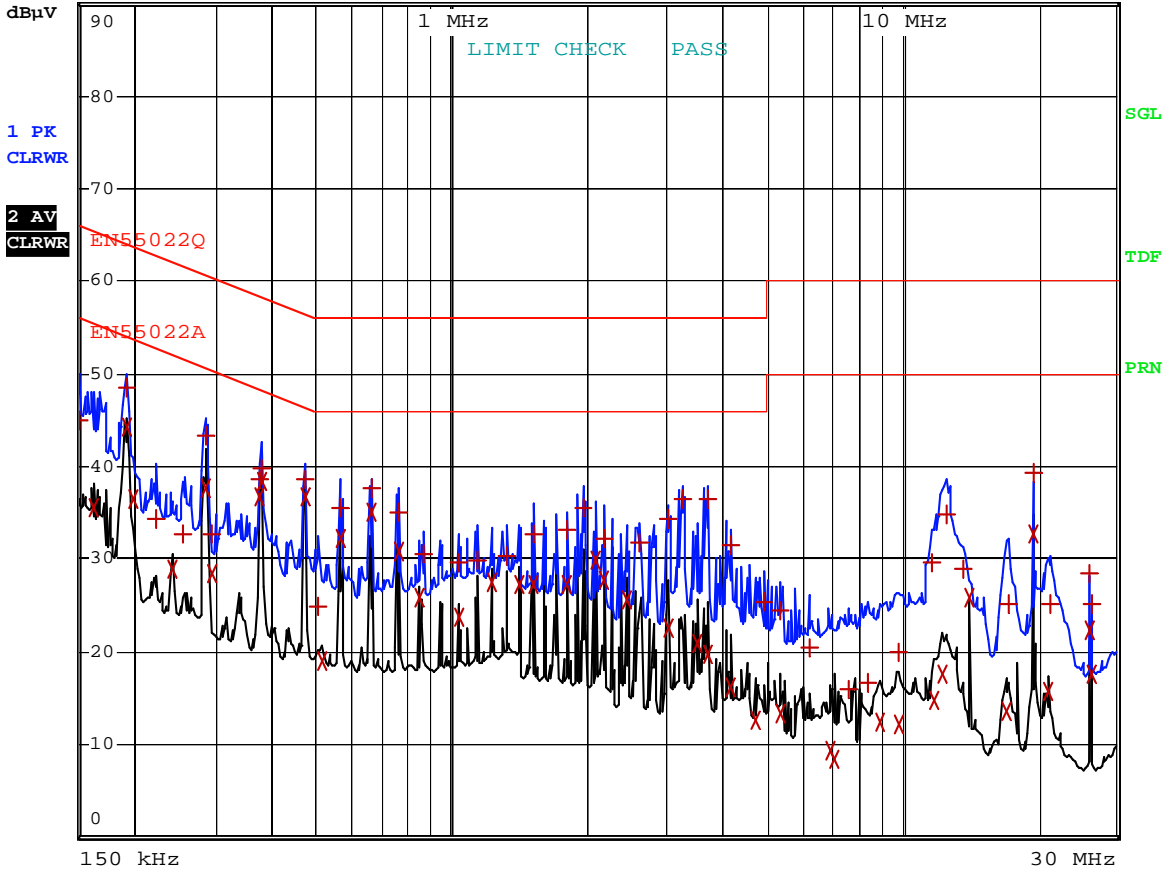

Comment: 42PX7DCV-UA RGB NEUTRAL

Date: 27.APR.2006 18:22:38