



**FCC 47 CFR PART 15 SUBPART C
INDUSTRY CANADA RSS-247 ISSUE 1**

CERTIFICATION TEST REPORT

FOR

CELLULAR PHONE WITH BLUETOOTH AND WLAN RADIOS

MODEL NUMBER: A1779

**FCC ID: BCG-E3086A
IC: 579C-E3086A**

REPORT NUMBER: 16U23310-E7V1

ISSUE DATE: AUGUST 26, 2016

Prepared for
**APPLE, INC.
1 INFINITE LOOP
CUPERTINO, CA 95014, U.S.A.**

Prepared by
**UL VERIFICATION SERVICES INC.
47173 BENICIA STREET
FREMONT, CA 94538, U.S.A.
TEL: (510) 771-1000
FAX: (510) 661-0888**



NVLAP LAB CODE 200065-0

Revision History

Rev.	Issue Date	Revisions	Revised By
V1	08/26/16	Initial Review	Chin Pang

TABLE OF CONTENTS

1. ATTESTATION OF TEST RESULTS	5
2. TEST METHODOLOGY	6
3. FACILITIES AND ACCREDITATION	6
4. CALIBRATION AND UNCERTAINTY	7
4.1. <i>MEASURING INSTRUMENT CALIBRATION</i>	<i>7</i>
4.2. <i>SAMPLE CALCULATION</i>	<i>7</i>
4.3. <i>MEASUREMENT UNCERTAINTY.....</i>	<i>7</i>
5. EQUIPMENT UNDER TEST	8
5.1. <i>DESCRIPTION OF EUT</i>	<i>8</i>
5.2. <i>MAXIMUM OUTPUT POWER.....</i>	<i>8</i>
5.3. <i>DESCRIPTION OF AVAILABLE ANTENNAS</i>	<i>8</i>
5.4. <i>SOFTWARE AND FIRMWARE.....</i>	<i>8</i>
5.5. <i>WORST-CASE CONFIGURATION AND MODE.....</i>	<i>9</i>
5.6. <i>DESCRIPTION OF TEST SETUP.....</i>	<i>10</i>
6. TEST AND MEASUREMENT EQUIPMENT	16
7. ANTENNA PORT TEST RESULTS	17
7.1. <i>ON TIME AND DUTY CYCLE.....</i>	<i>17</i>
7.2. <i>HIGH POWER BASIC DATA RATE GFSK MODULATION.....</i>	<i>19</i>
7.2.1. <i>99% AND 20 dB BANDWIDTH</i>	<i>19</i>
7.2.2. <i>HOPPING FREQUENCY SEPARATION</i>	<i>22</i>
7.2.3. <i>NUMBER OF HOPPING CHANNELS.....</i>	<i>23</i>
7.2.4. <i>AVERAGE TIME OF OCCUPANCY</i>	<i>26</i>
7.2.5. <i>OUTPUT POWER</i>	<i>30</i>
7.2.6. <i>AVERAGE POWER.....</i>	<i>31</i>
7.2.7. <i>CONDUCTED SPURIOUS EMISSIONS.....</i>	<i>32</i>
7.3. <i>HIGH POWER ENHANCED DATA RATE DQPSK MODULATION.....</i>	<i>37</i>
7.3.1. <i>OUTPUT POWER</i>	<i>37</i>
7.3.2. <i>AVERAGE POWER.....</i>	<i>38</i>
7.4. <i>HIGH POWER ENHANCED DATA RATE 8PSK MODULATION</i>	<i>39</i>
7.4.1. <i>20 dB AND 99% BANDWIDTH</i>	<i>39</i>
7.4.2. <i>HOPPING FREQUENCY SEPARATION</i>	<i>42</i>
7.4.3. <i>NUMBER OF HOPPING CHANNELS.....</i>	<i>43</i>
7.4.4. <i>AVERAGE TIME OF OCCUPANCY</i>	<i>46</i>
7.4.5. <i>OUTPUT POWER</i>	<i>50</i>
7.4.6. <i>AVERAGE POWER.....</i>	<i>51</i>
7.4.7. <i>CONDUCTED SPURIOUS EMISSIONS.....</i>	<i>52</i>
8. RADIATED TEST RESULTS.....	57
8.1. <i>LIMITS AND PROCEDURE.....</i>	<i>57</i>

8.2.	TRANSMITTER ABOVE 1 GHz	58
8.2.1.	HIGH POWER BASIC DATA RATE GFSK MODULATION.....	58
8.2.2.	HIGH POWER ENHANCED DATA RATE 8PSK MODULATION	68
8.3.	WORST-CASE BELOW 1 GHz.....	78
8.4.	WORST-CASE ABOVE 18 GHz	80
9.	AC POWER LINE CONDUCTED EMISSIONS.....	82
9.1.	EUT POWERED BY AC/DC ADAPTER VIA USB CABLE	83
9.2.	EUT POWERED BY HOST PC VIA USB CABLE	85
10.	SETUP PHOTOS	87

1. ATTESTATION OF TEST RESULTS

COMPANY NAME: APPLE, INC.
1 INFINITE LOOP
CUPERTINO, CA 95014, U.S.A.

EUT DESCRIPTION: CELLULAR PHONE WITH BLUETOOTH AND WLAN RADIOS

MODEL: A1779

SERIAL NUMBER: C39S602ZHLMT (CONDUCTED), C7CS100ZHGJC(RADIATED)

DATE TESTED: AUGUST 24-26, 2016

APPLICABLE STANDARDS	
STANDARD	TEST RESULTS
CFR 47 Part 15 Subpart C	Pass
INDUSTRY CANADA RSS-247 Issue 1	Pass
INDUSTRY CANADA RSS-GEN Issue 4	Pass

UL Verification Services Inc. tested the above equipment in accordance with the requirements set forth in the above standards. All indications of Pass/Fail in this report are opinions expressed by UL Verification Services Inc. based on interpretations and/or observations of test results. Measurement Uncertainties were not taken into account and are published for informational purposes only. The test results show that the equipment tested is capable of demonstrating compliance with the requirements as documented in this report.

Note: The results documented in this report apply only to the tested sample, under the conditions and modes of operation as described herein. This document may not be altered or revised in any way unless done so by UL Verification Services Inc. and all revisions are duly noted in the revisions section. Any alteration of this document not carried out by UL Verification Services Inc. will constitute fraud and shall nullify the document. This report must not be used by the client to claim product certification, approval, or endorsement by NVLAP, NIST, any agency of the Federal Government, or any agency of any government.

Approved & Released For
UL Verification Services Inc. By:

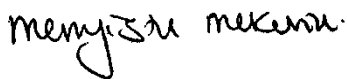

MENGISTU MEKURIA
SENIOR ENGINEER
UL VERIFICATION SERVICES INC.

Prepared By:



ERIC YU
EMC ENGINEER
UL VERIFICATION SERVICES INC.

2. TEST METHODOLOGY

The tests documented in this report were performed in accordance with FCC CFR 47 Part 2, FCC CFR 47 Part 15, ANSI C63.10-2013, RSS-GEN Issue 4, and RSS-247 Issue 1.

3. FACILITIES AND ACCREDITATION

The test sites and measurement facilities used to collect data are located at 47173 and 47266 Benicia Street, Fremont, California, USA. Line conducted emissions are measured only at the 47173 address. The following table identifies which facilities were utilized for radiated emission measurements documented in this report. Specific facilities are also identified in the test results sections.

47173 Benicia Street	47266 Benicia Street
<input type="checkbox"/> Chamber A	<input type="checkbox"/> Chamber D
<input type="checkbox"/> Chamber B	<input checked="" type="checkbox"/> Chamber E
<input type="checkbox"/> Chamber C	<input type="checkbox"/> Chamber F
	<input type="checkbox"/> Chamber G
	<input checked="" type="checkbox"/> Chamber H

The above test sites and facilities are covered under FCC Test Firm Registration # 208313. Chambers A through H are covered under Industry Canada company address code 2324B with site numbers 2324B -1 through 2324B-8, respectively.

UL Verification Services Inc. is accredited by NVLAP, Laboratory Code 200065-0. The full scope of accreditation can be viewed at <http://ts.nist.gov/standards/scopes/2000650.htm>.

4. CALIBRATION AND UNCERTAINTY

4.1. MEASURING INSTRUMENT CALIBRATION

The measuring equipment utilized to perform the tests documented in this report has been calibrated in accordance with the manufacturer's recommendations, and is traceable to recognized national standards.

4.2. SAMPLE CALCULATION

Where relevant, the following sample calculation is provided:

$$\begin{aligned} \text{Field Strength (dBuV/m)} &= \text{Measured Voltage (dBuV)} + \text{Antenna Factor (dB/m)} + \\ &\text{Cable Loss (dB)} - \text{Preamp Gain (dB)} \\ 36.5 \text{ dBuV} + 18.7 \text{ dB/m} + 0.6 \text{ dB} - 26.9 \text{ dB} &= 28.9 \text{ dBuV/m} \end{aligned}$$

4.3. MEASUREMENT UNCERTAINTY

Where relevant, the following measurement uncertainty levels have been estimated for tests performed on the apparatus:

PARAMETER	UNCERTAINTY
Conducted Disturbance, 9KHz to 0.15 MHz	3.84 dB
Conducted Disturbance, 0.15 to 30 MHz	3.65 dB
Radiated Disturbance, 9KHz to 30 MHz	3.15 dB
Radiated Disturbance, 30 to 1000 MHz	5.36 dB
Radiated Disturbance, 1000 to 18000 MHz	4.32 dB
Radiated Disturbance, 18000 to 26000 MHz	4.45 dB
Radiated Disturbance, 26000 to 40000 MHz	5.24 dB

Uncertainty figures are valid to a confidence level of 95%.

5. EQUIPMENT UNDER TEST

5.1. DESCRIPTION OF EUT

The EUT Model A1779 is a mobile phone with multimedia functions (music, application support, and video), cellular GSM/GPRS/EGPRS/CDMA/WCDMA/HSPA+/DC-HSDPA/LTE-radio, IEEE 802.11a/b/g/n/ac, NFC and Bluetooth radio. The rechargeable battery is not user accessible.

5.2. MAXIMUM OUTPUT POWER

The transmitter has a maximum peak conducted output power as follows:

Frequency Range (MHz)	Mode	Output Power (dBm)	Output Power (mW)
2402 - 2480	Basic GFSK	16.79	47.75
2402 - 2480	DQPSK	19.39	86.90
2402 - 2480	Enhanced 8PSK	19.48	88.72

5.3. DESCRIPTION OF AVAILABLE ANTENNAS

Frequency Band (GHz)	Antenna Gain (dBi)
2.4	-1.85

5.4. SOFTWARE AND FIRMWARE

The firmware installed in the EUT during testing was 14.1.39.180.
The test utility software used during testing was BlueTool.

5.5. WORST-CASE CONFIGURATION AND MODE

Radiated emission and power line conducted emission were performed with the EUT set to transmit at the channel with highest output power as worst-case scenario.

The fundamental of the EUT was investigated in three orthogonal orientations X/Y/Z, it was determined that X orientation was worst-case orientation. Therefore, all final radiated testing was performed with the EUT in X orientation.

Worst-case data rates were:

GFSK mode: DH5
8PSK mode: 3-DH5

Preliminary data showed DQPSK mode with lower power. Therefore, testing was performed on GFSK and 8PSK modes only

For simultaneous transmission of multiple channels from the same antenna in the 2.4GHz and 5GHz bands, tests were conducted for various configurations having the highest power. No noticeable new emission was found.

There are two vendors of the WiFi/Bluetooth radio modules: variant 1 and variant 2. The Wi-Fi/Bluetooth radio modules have the same mechanical outline (e.g., the same package dimension and pin-out layout), use the same on-board antenna matching circuit, have an identical antenna structure, and are built and tested to conform to the same specifications and to operate within the same tolerances.

Baseline testing was performed on the two variants to determine the worst case on all conducted power and radiated emissions.

5.6. DESCRIPTION OF TEST SETUP

SUPPORT EQUIPMENT

Support Equipment List				
Description	Manufacturer	Model	Serial Number	FCC ID
Laptop	Dell	Latitude 3540	9J6WQZ1	NA
Laptop Power Supply	Dell	LA65NM130	OJNKWD	NA

I/O CABLES (CONDUCTED TEST)

I/O Cable List						
Cable No	Port	# of identical ports	Connector Type	Cable Type	Cable Length (m)	Remarks
1	Antenna	1	SMA	Un-Shielded	0.2	To spectrum Analyzer
2	USB	2	USB	Shielded	1	N/A

I/O CABLES (RADIATED ABOVE 1 GHZ)

I/O Cable List						
Cable No	Port	# of identical ports	Connector Type	Cable Type	Cable Length (m)	Remarks
None Used						

I/O CABLES (BELOW 1 GHZ)

I/O Cable List						
Cable No	Port	# of identical ports	Connector Type	Cable Type	Cable Length (m)	Remarks
1	AC	1	AC	Un-shielded	3	N/A

I/O CABLES (AC LINE CONDUCTED: AC/DC ADAPTER & LAPTOP CONFIGURATION)

I/O Cable List						
Cable No	Port	# of identical	Connector Type	Cable Type	Cable Length (m)	Remarks
1	AC	1	AC	Un-shielded	3	N/A
2	Power Adapter	1	AC	Un-shielded	3	N/A

TEST SETUP- CONDUCTED PORT

The EUT was tested connected to a host Laptop via USB cable adapter and spectrum analyzer to antenna port. Test software exercised the EUT.

SETUP DIAGRAM

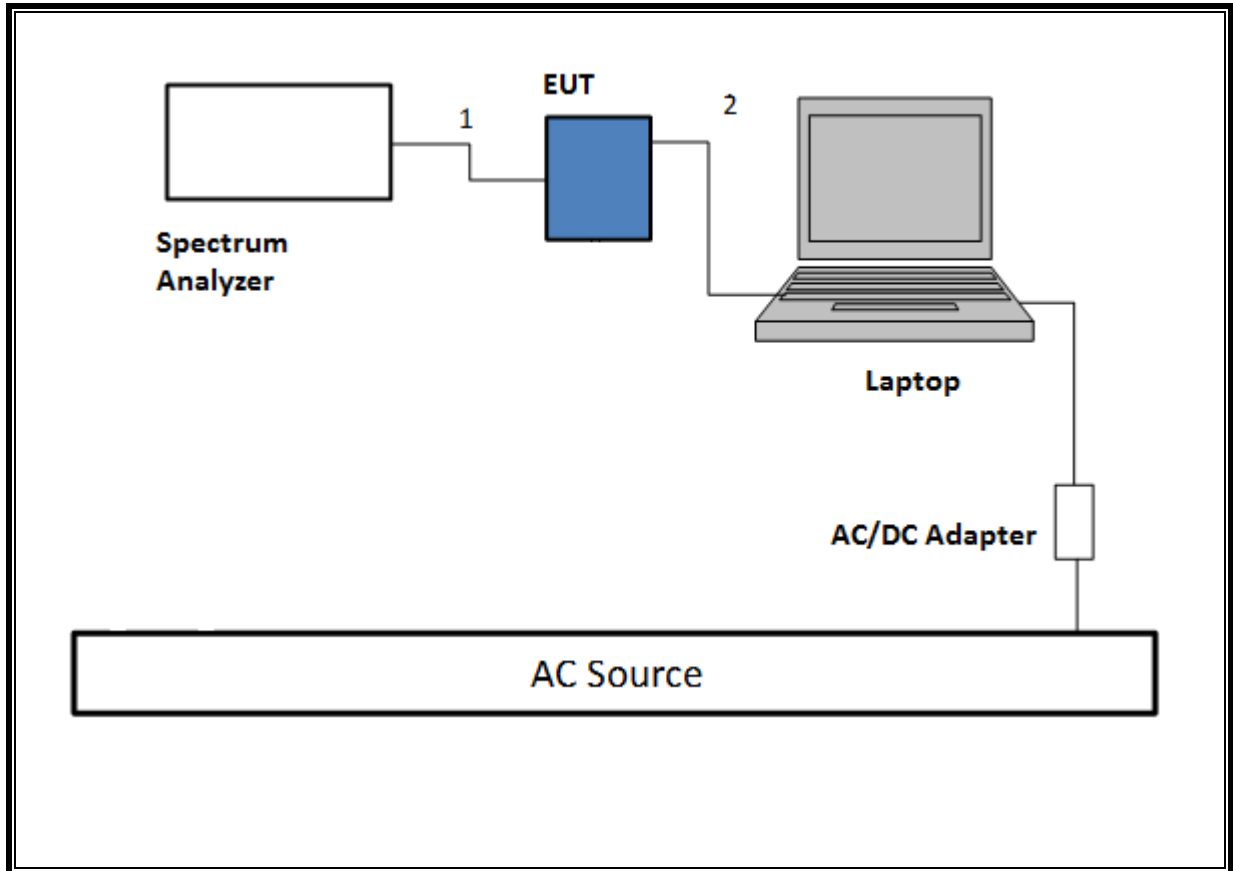

TEST SETUP- RADIATED-ABOVE 1 GHZ

The EUT was powered by battery. Test software exercised the EUT.

SETUP DIAGRAM

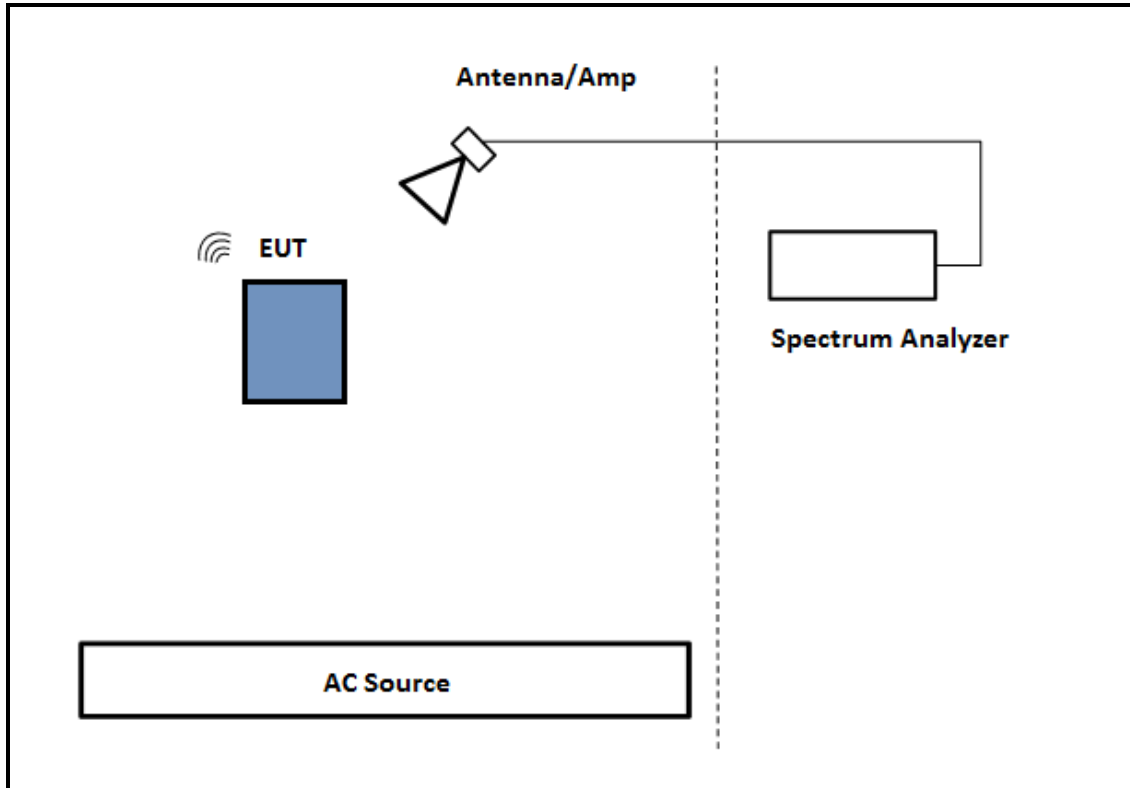

TEST SETUP- BELOW 1GHZ

The EUT was powered by AC cord. Test software exercised the EUT.

SETUP DIAGRAM

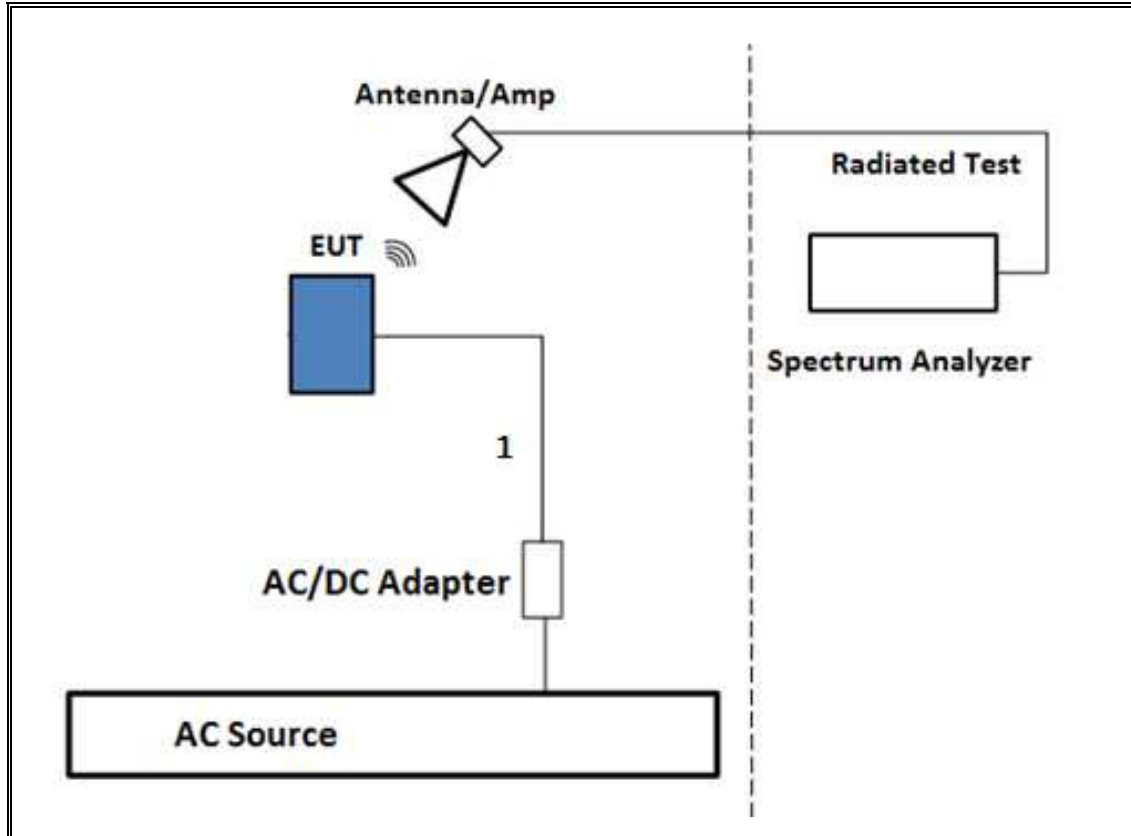

TEST SETUP- AC LINE CONDUCTED: AC/DC ADAPTER

The EUT was tested with powered by AC/DC adapter via USB cable. Test software exercised the EUT.

SETUP DIAGRAM

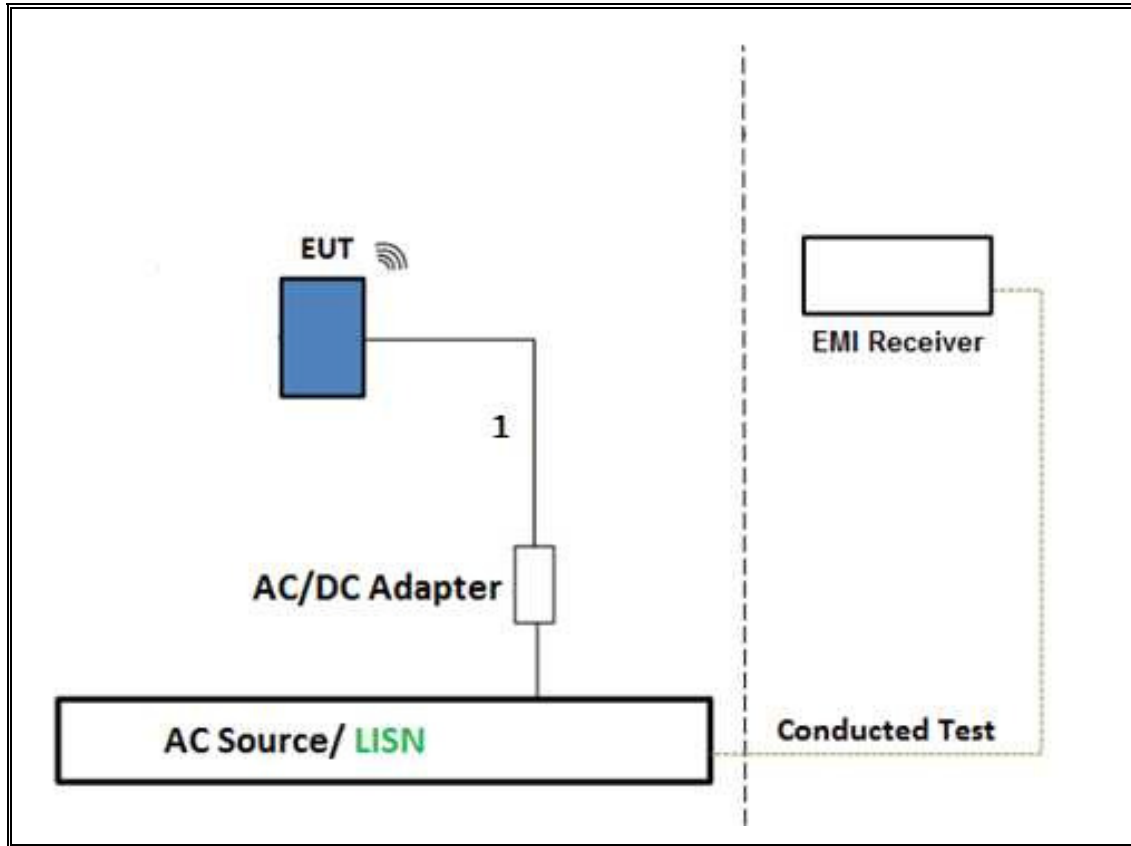

TEST SETUP- AC LINE CONDUCTED: LAPTOP CONFIGURATION

The EUT was tested with powered by host PC via USB cable. Test software exercised the EUT.

SETUP DIAGRAM

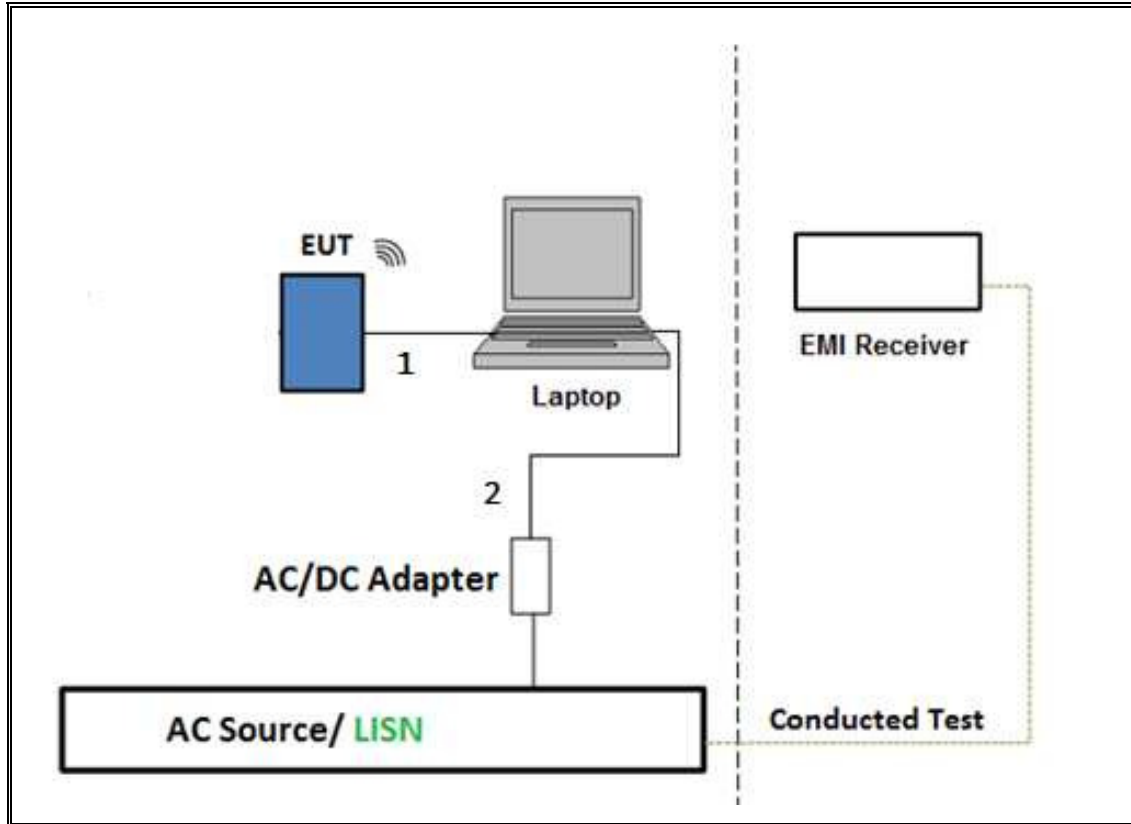

6. TEST AND MEASUREMENT EQUIPMENT

The following test and measurement equipment was utilized for the tests documented in this report:

Test Equipment List				
Description	Manufacturer	Model	T Number	Cal Due
Antenna, Horn 1-18GHz	ETS Lindgren	3117	T120	4/5/2017
Antenna, Broadband Hybrid, 30MHz to 2000MHz	Sunol Sciences	JB3	T122	1/29/2017
Amplifier, 10KHz to 1GHz, 32dB	Sonoma	310N	T173	6/17/2017
Spectrum Analyzer, PXA, 3Hz to 44GHz	Agilent	N9030A	T341	10/14/2016
Antenna, Horn 1-18GHz	ETS Lindgren	3117	T862	4/18/2017
Antenna, Broadband Hybrid, 30MHz to 2000MHz	Sunol Sciences	JB3	T899	5/26/2017
Amplifier, 1 - 18GHz	Miteq	AFS42-00101800-25-S-42	T491	5/31/2017
Amplifier, 10KHz to 1GHz, 32dB	Sonoma	310N	T834	6/17/2017
Power Meter, P-series single channel	Agilent	N1911A	T1271	7/8/2017
Power Sensor, P - series, 50MHz to 18GHz, Wideband	Agilent	N1921A	T1228	6/20/2017
Antenna, Horn 18 to 26.5GHz	ARA	MWH-1826	T447	6/16/2017
Spectrum Analyzer, 40 GHz	Agilent	8564E	T106	8/13/2016
Amplifier, 1 to 26.5GHz, 23.5dB Gain minimum	Keysight	8449B	T402	7/5/2017
AC Line Conducted				
EMI Test Receiver 9KHz-7GHz	Rohde & Schwarz	ESCI7	100935	9/16/2016
LISN for Conducted Emissions CISPR-16	Fischer	50/250-25-2	161124	9/16/2016
Power Cable, Line Conducted Emissions	UL	PG1	N/A	7/28/2016
UL SOFTWARE				
* Radiated Software	UL	UL EMC	Ver 9.5, June 24, 2015	
* Conducted Software	UL	UL EMC	Ver 4.0, January 11, 2016	

Note: * indicates automation software version used in the compliance certification testing

**Testing is completed before equipment expiration date.

7. ANTENNA PORT TEST RESULTS

7.1. ON TIME AND DUTY CYCLE

LIMITS

None; for reporting purposes only.

PROCEDURE

KDB 558074 Zero-Span Spectrum Analyzer Method.

ON TIME AND DUTY CYCLE RESULTS

Mode	ON Time B (msec)	Period (msec)	Duty Cycle x (linear)	Duty Cycle (%)	Duty Cycle Correction Factor (dB)	1/B Minimum VBW (kHz)
Bluetooth GFSK High Power	1.000	1.000	1.000	100.00%	0.00	0.010
Bluetooth 8PSK High Power	1.000	1.000	1.000	100.00%	0.00	0.010
Bluetooth GFSK Low Power	1.000	1.000	1.000	100.00%	0.00	0.010
Bluetooth 8PSK Low Power	1.000	1.000	1.000	100.00%	0.00	0.010

DUTY CYCLE PLOTS

HOPPING OFF

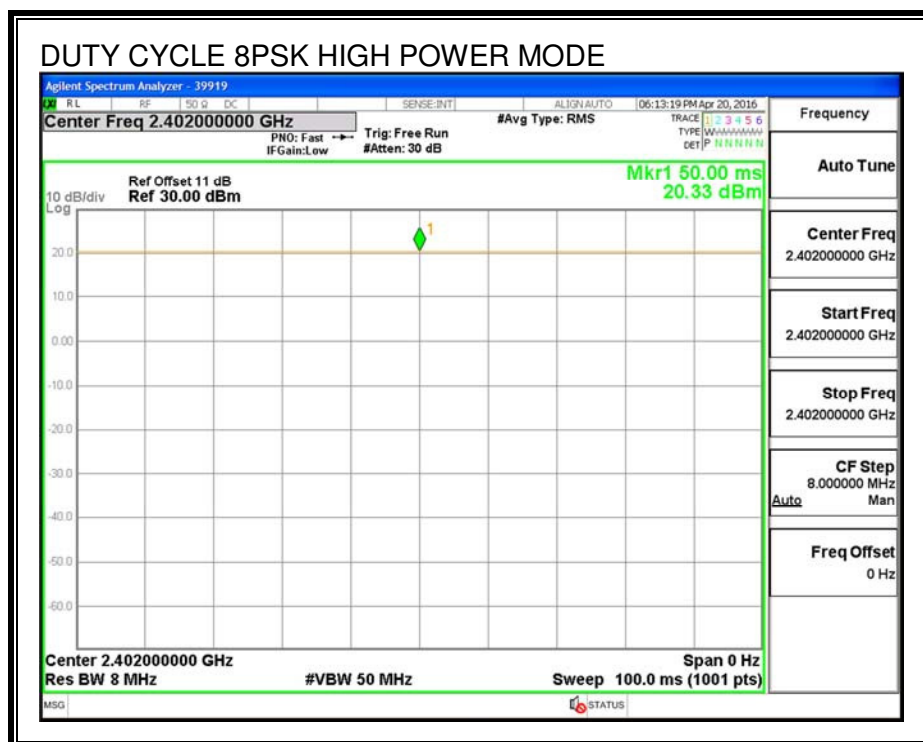
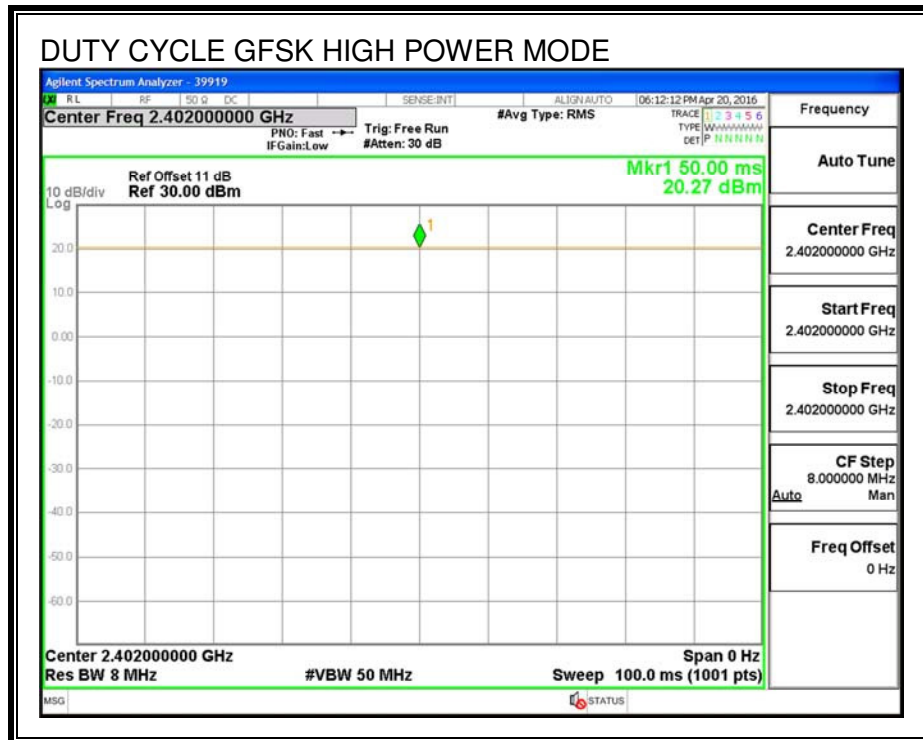

7.2. HIGH POWER BASIC DATA RATE GFSK MODULATION

7.2.1. 99% AND 20 dB BANDWIDTH

LIMIT

None; for reporting purposes only.

TEST PROCEDURE

The transmitter output is connected to a spectrum analyzer. The RBW is set to $\geq 1\%$ of the 20 dB bandwidth. The VBW is set to \geq RBW. The sweep time is coupled.

RESULTS

Channel	Frequency (MHz)	99% Bandwidth (KHz)	20 dB Bandwidth (KHz)
Low	2402	901.48	914.00
Middle	2441	905.22	913.60
High	2480	1062.5	1192.00

99% AND 20 dB BANDWIDTH

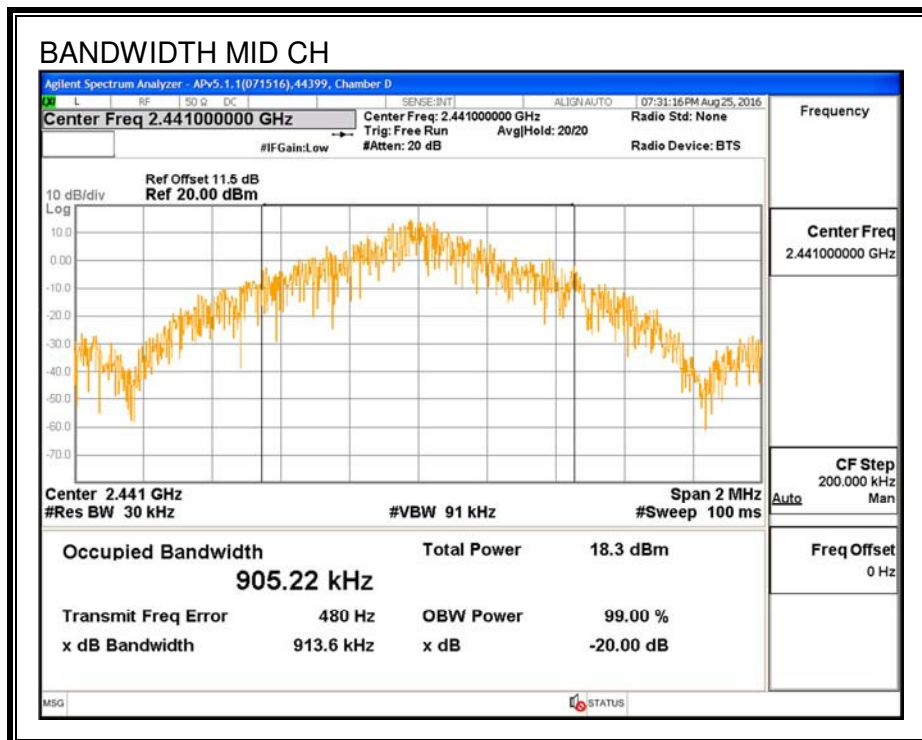
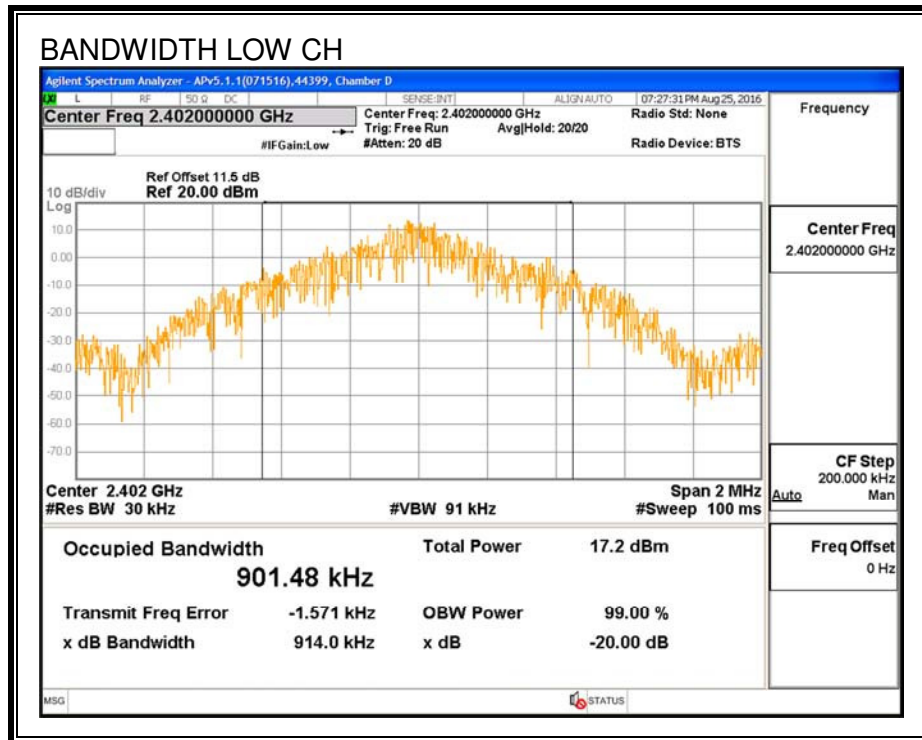

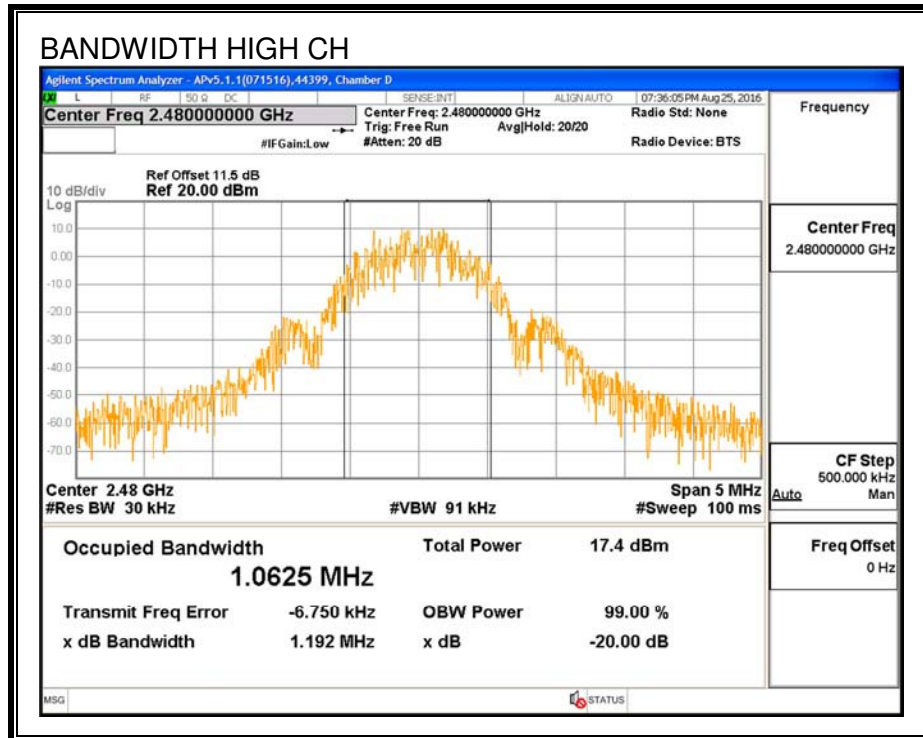

7.2.2. HOPPING FREQUENCY SEPARATION

LIMIT

FCC §15.247 (a) (1)

IC RSS-247 (5.1) (2)

Frequency hopping systems shall have hopping channel carrier frequencies separated by a minimum of 25 kHz or the 20 dB bandwidth of the hopping channel, whichever is greater.

Alternatively, frequency hopping systems operating in the 2400-2483.5 MHz band may have hopping channel carrier frequencies that are separated by 25 kHz or two-thirds of the 20 dB bandwidth of the hopping channel, whichever is greater, provided the systems operate with an output power no greater than 125 mW.

TEST PROCEDURE

The transmitter output is connected to a spectrum analyzer. The RBW is set to 300 kHz and the VBW is set to 910 kHz. The sweep time is coupled.

RESULTS

HOPPING FREQUENCY SEPARATION

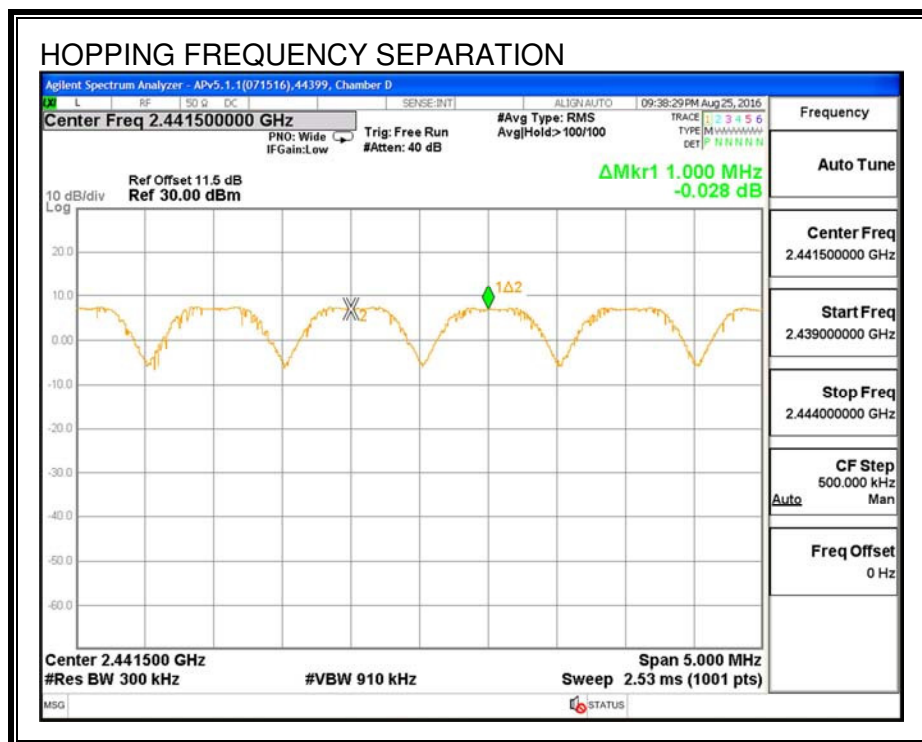

7.2.3. NUMBER OF HOPPING CHANNELS

LIMIT

FCC §15.247 (a) (1) (iii)

IC RSS-247 (5.1) (4)

Frequency hopping systems in the 2400 – 2483.5 MHz band shall use at least 15 non-overlapping channels.

TEST PROCEDURE

The transmitter output is connected to a spectrum analyzer. The span is set to cover the entire authorized band, in either a single sweep or in multiple contiguous sweeps. The RBW is set to a maximum of 1 % of the span. The analyzer is set to Max Hold.

RESULTS

Normal Mode: 79 Channels observed.

NUMBER OF HOPPING CHANNELS

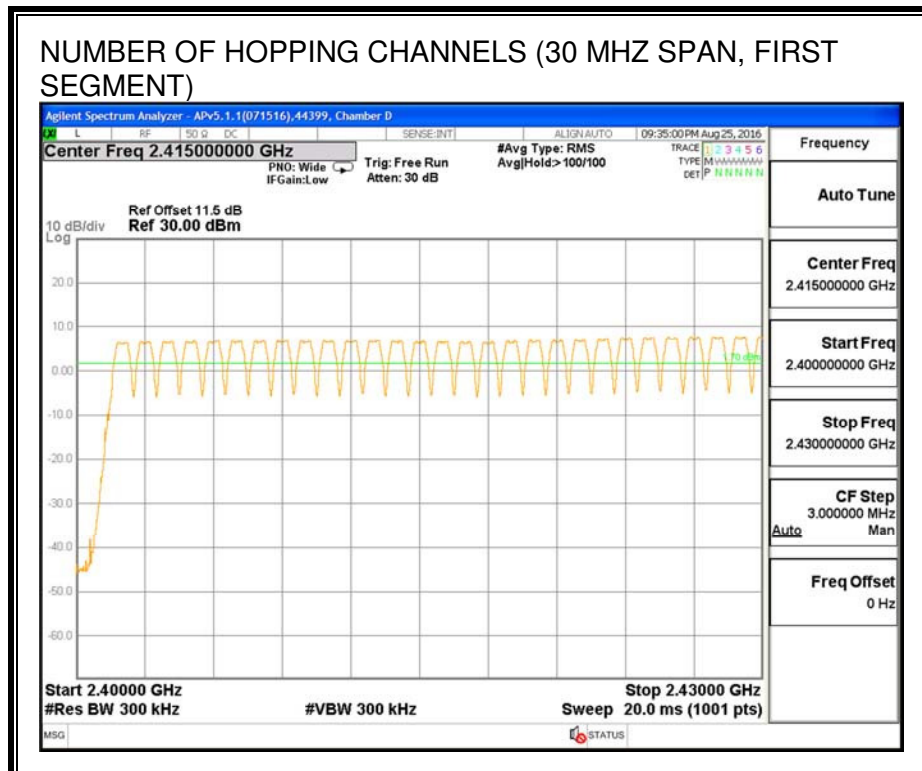
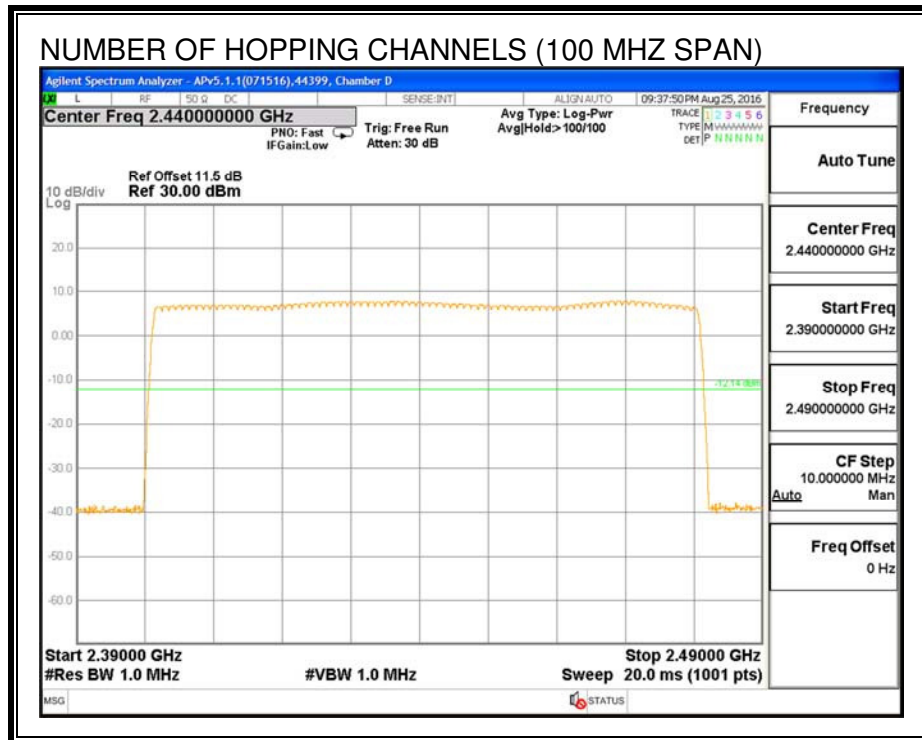

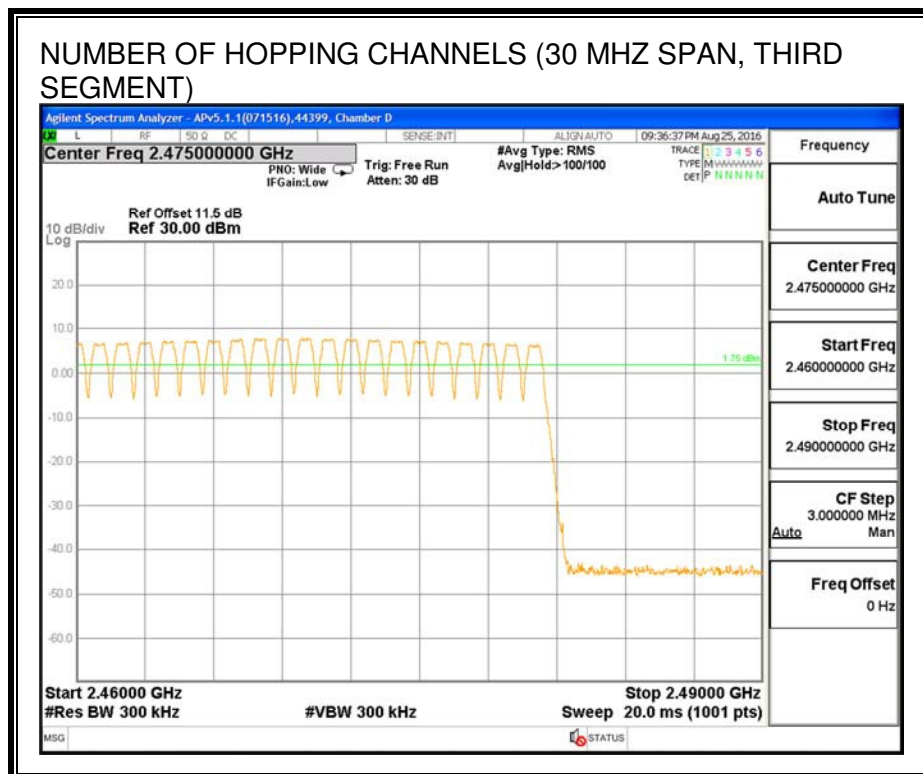
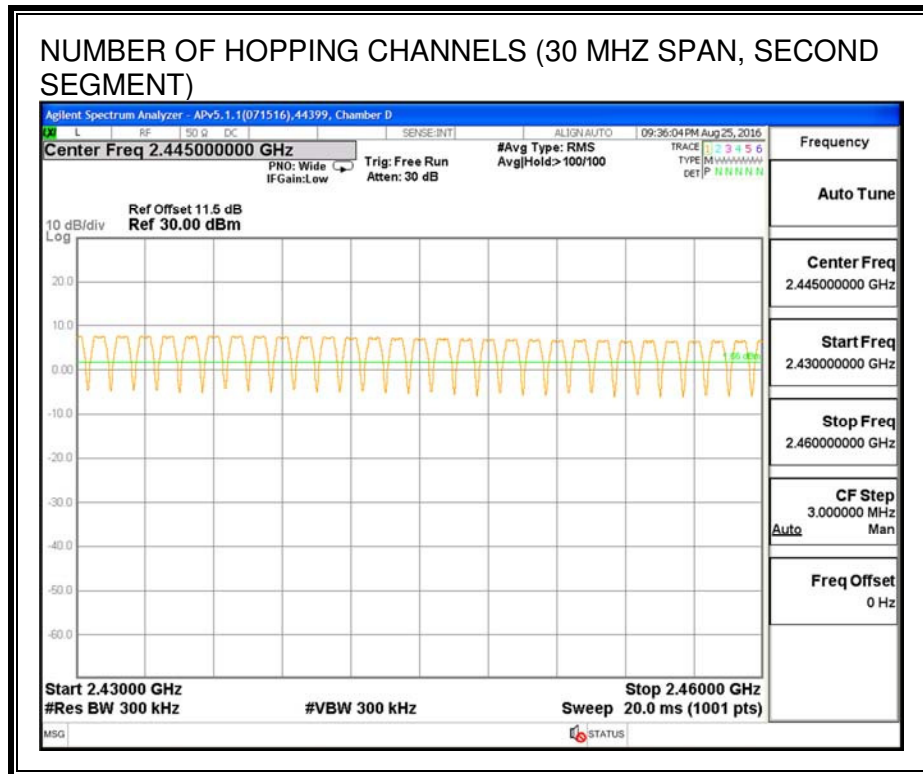

7.2.4. AVERAGE TIME OF OCCUPANCY

LIMIT

FCC §15.247 (a) (1) (iii)

IC RSS-247 (5.1) (4)

The average time of occupancy on any channel shall not be greater than 0.4 seconds within a period of 0.4 seconds multiplied by the number of hopping channels employed.

TEST PROCEDURE

The transmitter output is connected to a spectrum analyzer. The span is set to 0 Hz, centered on a single, selected hopping channel. The width of a single pulse is measured in a fast scan. The number of pulses is measured in a 3.16 second scan, to enable resolution of each occurrence.

The average time of occupancy in the specified 31.6 second period (79 channels * 0.4 s) is equal to $10 * (\# \text{ of pulses in } 3.16 \text{ s}) * \text{ pulse width}$.

For AFH mode, the average time of occupancy in the specified 8 second period (20 channels * 0.4 seconds) is equal to $10 * (\# \text{ of pulses in } 0.8 \text{ s}) * \text{ pulse width}$.

RESULTS

DH Packet	Pulse Width (msec)	Number of Pulses in 3.16 seconds	Average Time of Occupancy (sec)	Limit (sec)	Margin (sec)
GFSK Normal Mode					
DH1	0.395	32	0.126	0.4	-0.274
DH3	1.65	18	0.297	0.4	-0.103
DH5	2.892	12	0.347	0.4	-0.053
DH Packet	Pulse Width (msec)	Number of Pulses in 0.8 seconds	Average Time of Occupancy (sec)	Limit (sec)	Margin (sec)
GFSK AFH Mode					
DH1	0.395	8	0.032	0.4	-0.368
DH3	1.65	4.5	0.074	0.4	-0.326
DH5	2.892	3	0.087	0.4	-0.313

PULSE WIDTH - DH1



NUMBER OF PULSES IN 3.16 SECOND OBSERVATION PERIOD – DH1

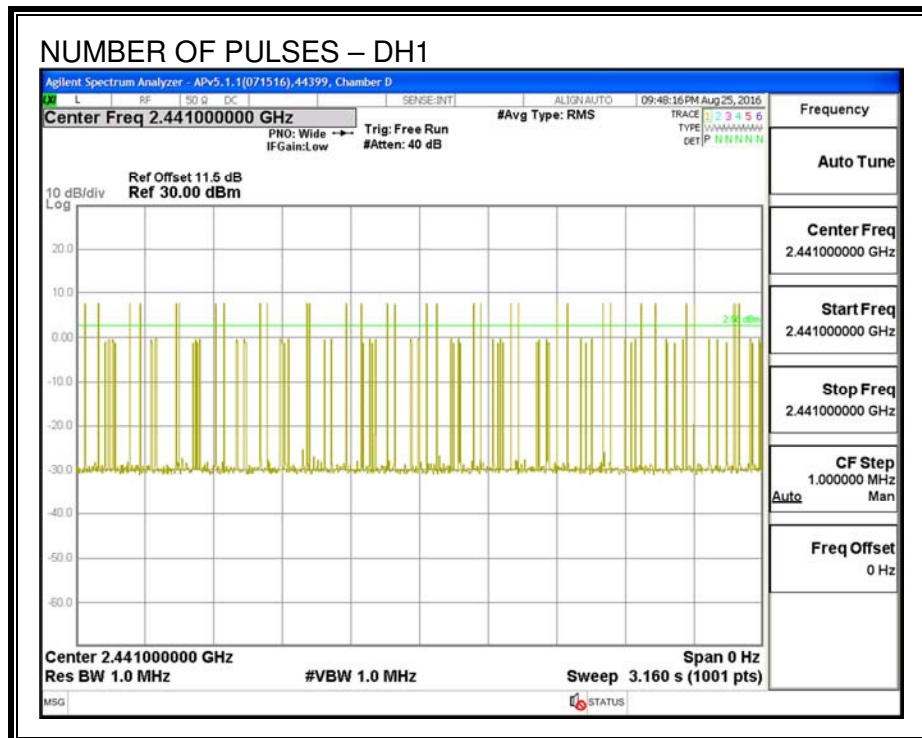

PULSE WIDTH – DH3

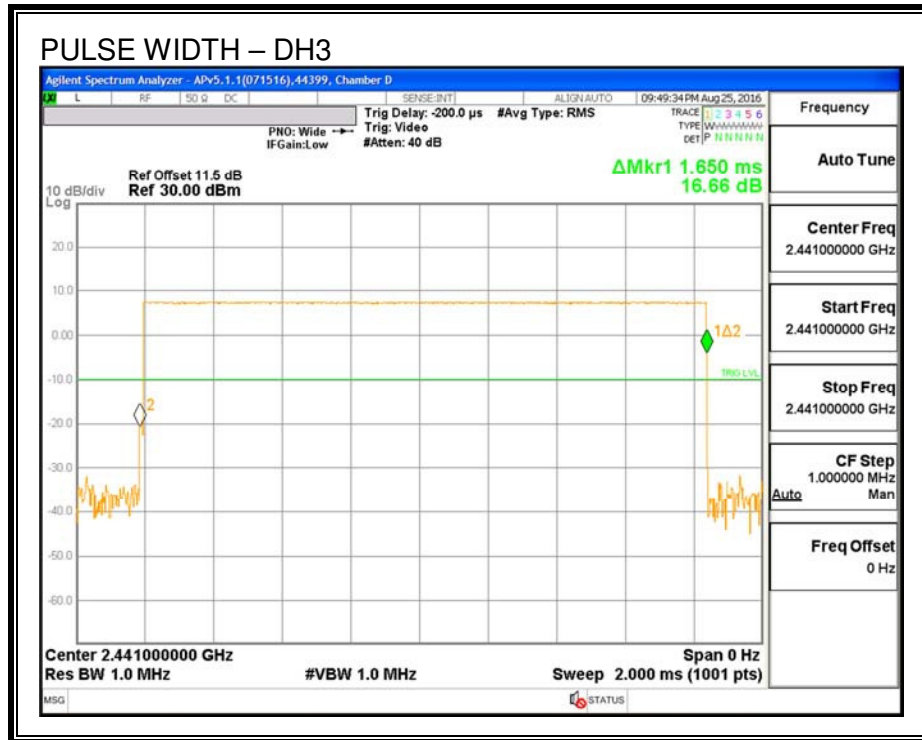

NUMBER OF PULSES IN 3.16 SECOND OBSERVATION PERIOD – DH3

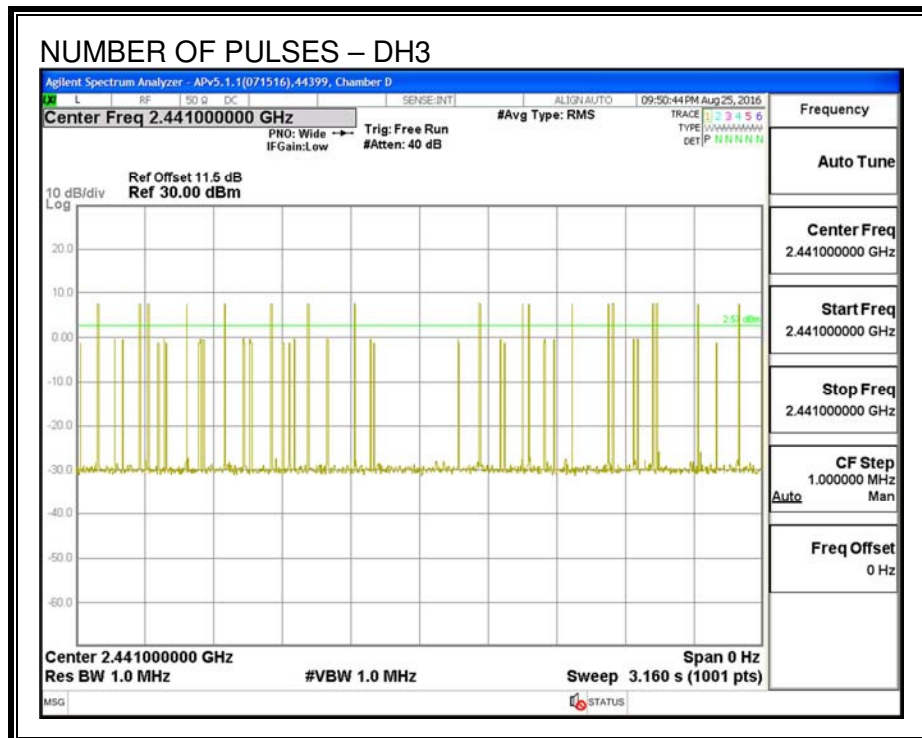

PULSE WIDTH – DH5

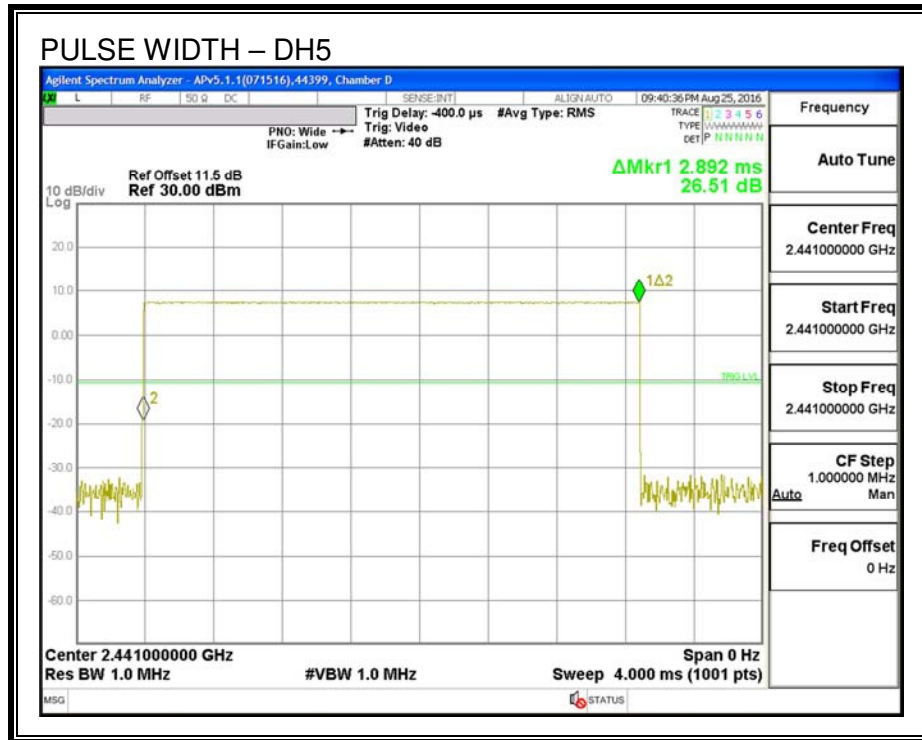

NUMBER OF PULSES IN 3.16 SECOND OBSERVATION PERIOD – DH5

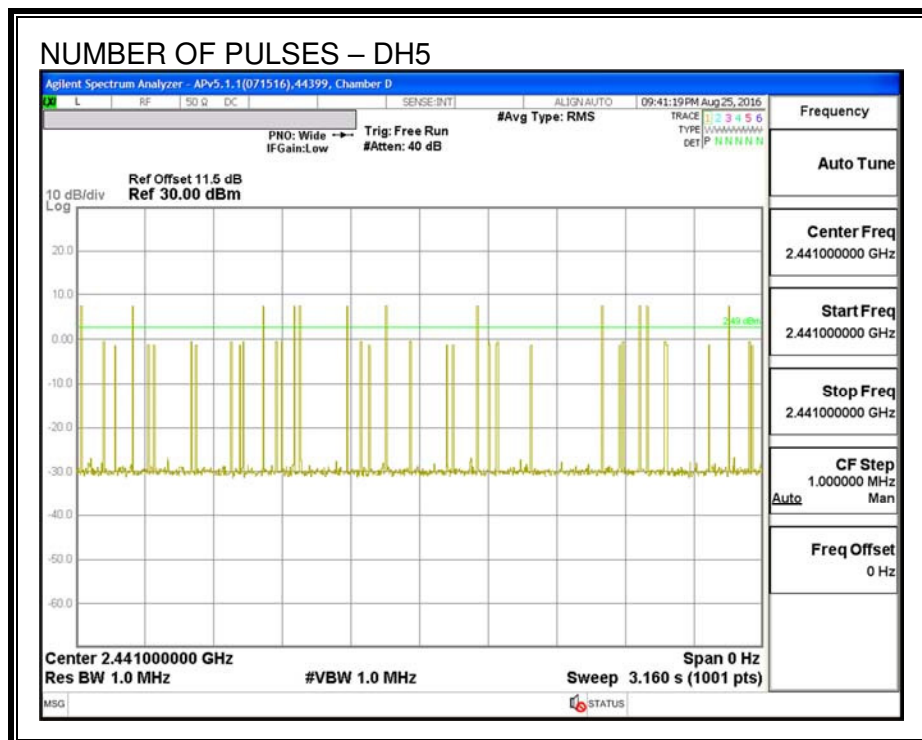

7.2.5. OUTPUT POWER

LIMIT

§15.247 (b) (1)

RSS-247 (5.4) (2)

The maximum antenna gain is less than 6 dBi, therefore the limit is 30 dBm.

Alternatively, frequency hopping systems operating in the 2400-2483.5 MHz band may have hopping channel carrier frequencies that are separated by 25 kHz or two-thirds of the 20 dB bandwidth of the hopping channel, whichever is greater, provided the systems operate with an output power no greater than 125 mW.

TEST PROCEDURE

The transmitter output is connected to a wideband peak power meter.

RESULTS

ID:	44399	Date:	8/25/16
------------	-------	--------------	---------

Channel	Frequency (MHz)	Output Power (dBm)	Limit (dBm)	Margin (dB)
Low	2402	16.77	21	-4.20
Middle	2441	16.79	21	-4.18
High	2480	16.67	21	-4.30

7.2.6. AVERAGE POWER

LIMIT

None; for reporting purposes only.

TEST PROCEDURE

The transmitter output is connected to a power meter.

RESULTS

The cable assembly insertion loss of 11 dB (including 10 dB pad and 1 dB cable) was entered as an offset in the power meter to allow for direct reading of power.

ID:	44399	Date:	8/25/16
------------	-------	--------------	---------

Channel	Frequency (MHz)	Average Power (dBm)
Low	2402	16.43
Middle	2441	16.45
High	2480	16.41

7.2.7. CONDUCTED SPURIOUS EMISSIONS

LIMITS

FCC §15.247 (d)

IC RSS-247 (5.5)

Limit = -20 dBc

TEST PROCEDURE

The transmitter output is connected to a spectrum analyzer. The resolution bandwidth is set to 100 kHz. The video bandwidth is set to 300 kHz.

The spectrum from 30 MHz to 26 GHz is investigated with the transmitter set to the lowest, middle, and highest channels.

The band edges at 2.4 and 2.4835 GHz are investigated with the transmitter set to the normal hopping mode.

RESULTS

SPURIOUS EMISSIONS, LOW CHANNEL

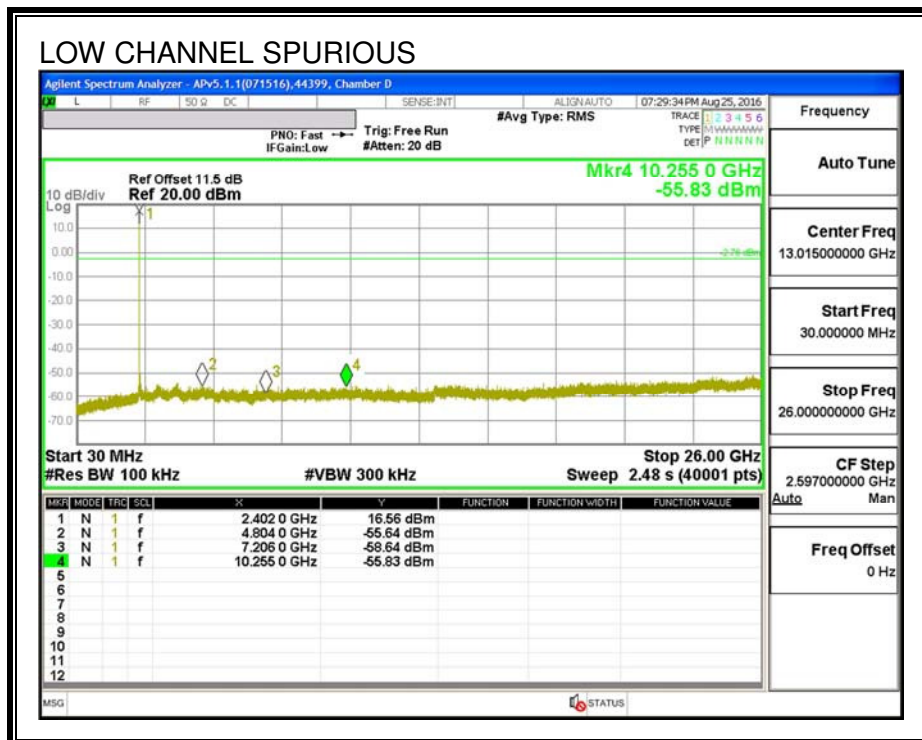
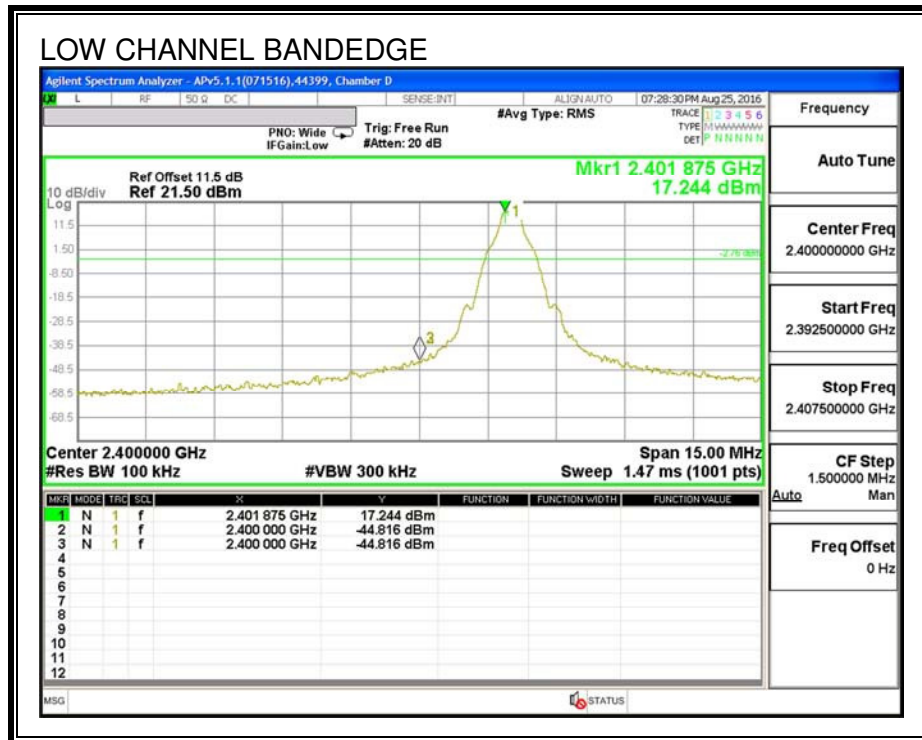

SPURIOUS EMISSIONS, MID CHANNEL

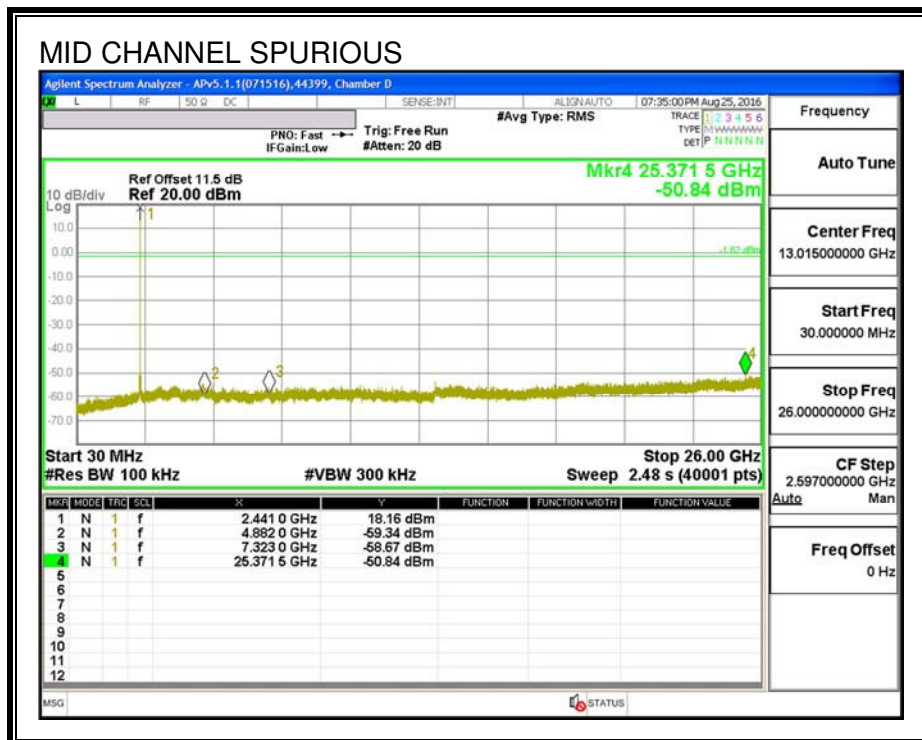
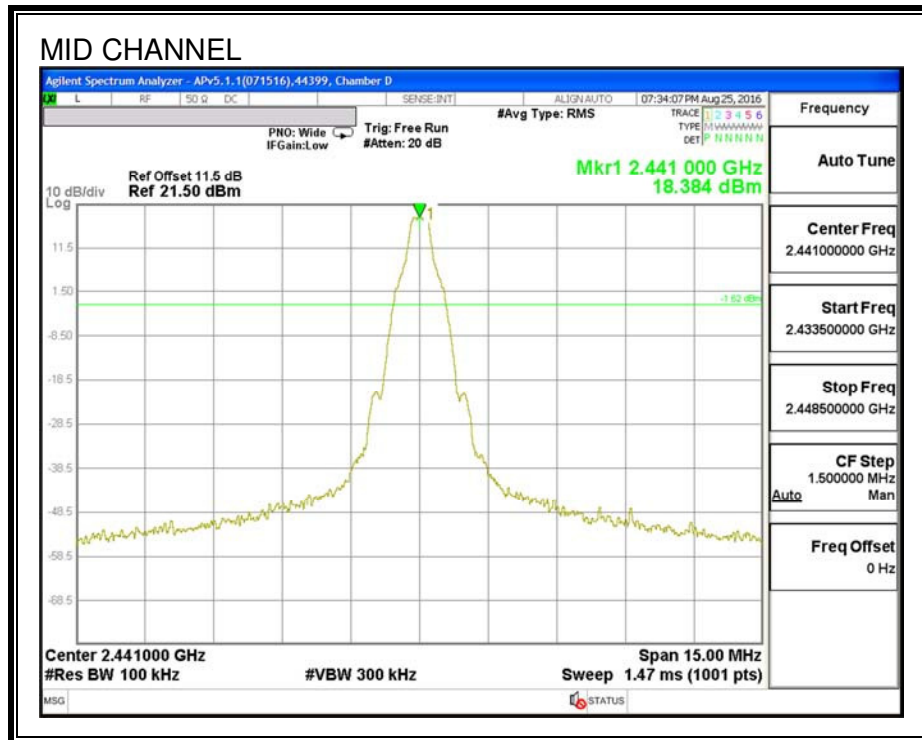

SPURIOUS EMISSIONS, HIGH CHANNEL

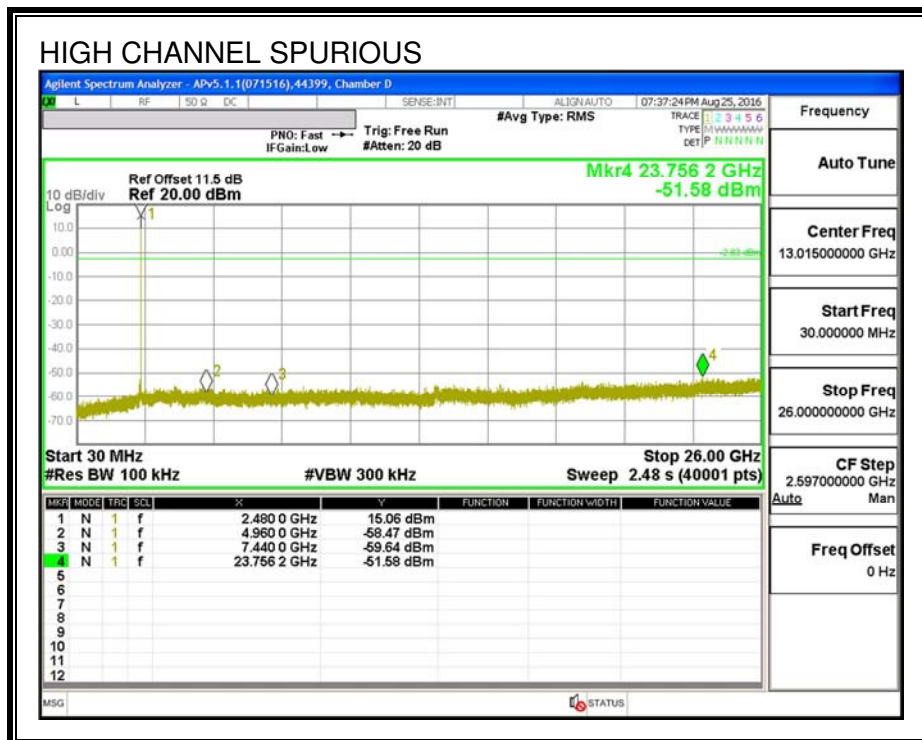
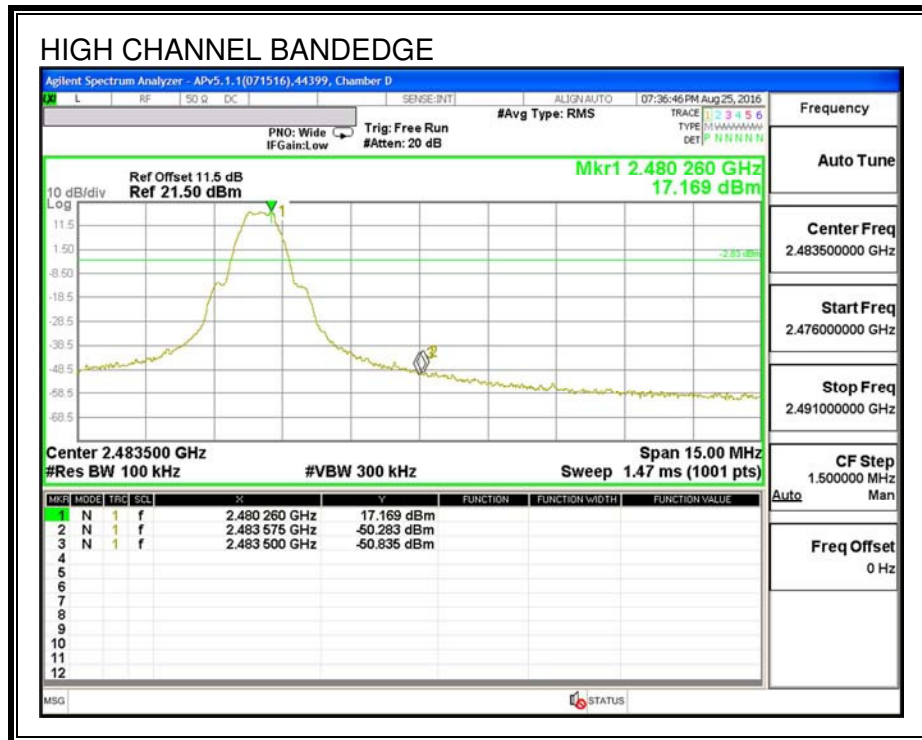

SPURIOUS BANDEGE EMISSIONS WITH HOPPING ON

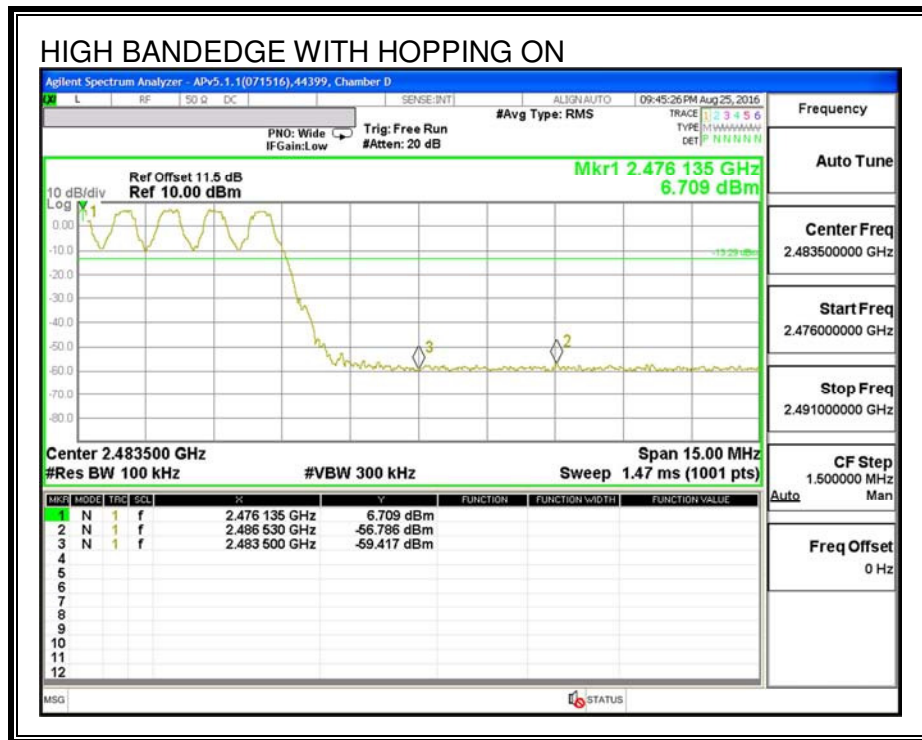
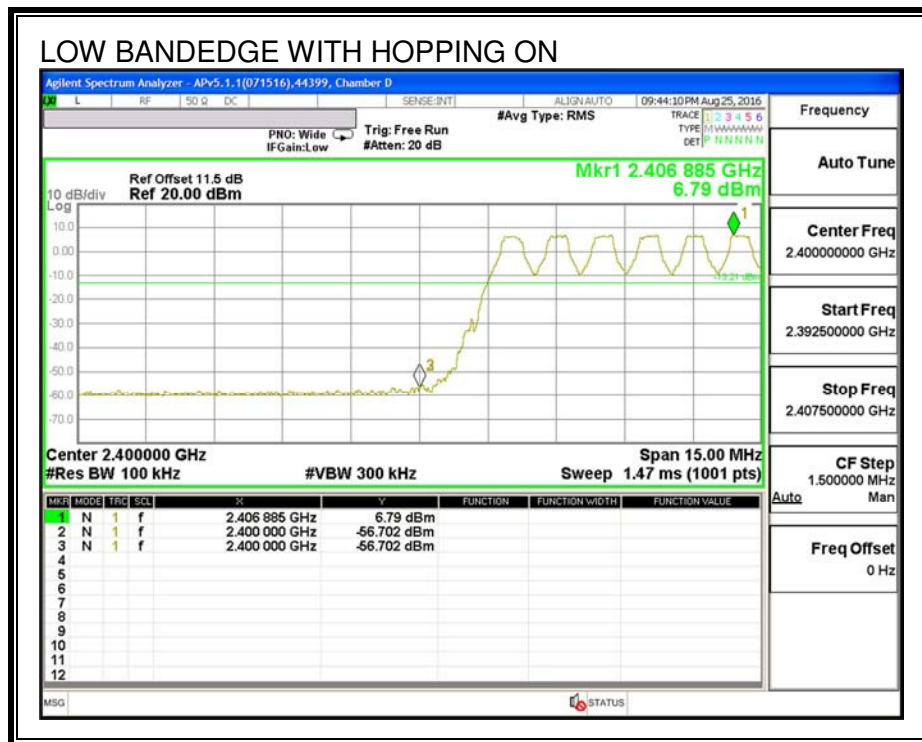

7.3. HIGH POWER ENHANCED DATA RATE DQPSK MODULATION

7.3.1. OUTPUT POWER

LIMIT

§15.247 (b) (1)

RSS-247 (5.4) (2)

The maximum antenna gain is less than 6 dBi, therefore the limit is 30 dBm.

Alternatively, frequency hopping systems operating in the 2400-2483.5 MHz band may have hopping channel carrier frequencies that are separated by 25 kHz or two-thirds of the 20 dB bandwidth of the hopping channel, whichever is greater, provided the systems operate with an output power no greater than 125 mW.

TEST PROCEDURE

The transmitter output is connected to a wideband peak power meter.

RESULTS

ID:	44399	Date:	8/25/16
------------	-------	--------------	---------

Channel	Frequency (MHz)	Output Power (dBm)	Limit (dBm)	Margin (dB)
Low	2402	19.32	21	-1.65
Middle	2441	19.39	21	-1.58
High	2480	19.22	21	-1.75

7.3.2. AVERAGE POWER

LIMIT

None; for reporting purposes only.

TEST PROCEDURE

The transmitter output is connected to a power meter.

RESULTS

The cable assembly insertion loss of 11 dB (including 10 dB pad and 1 dB cable) was entered as an offset in the power meter to allow for direct reading of power.

ID:	44399	Date:	8/25/16
------------	-------	--------------	---------

Channel	Frequency (MHz)	Average Power (dBm)
Low	2402	15.89
Middle	2441	16.12
High	2480	15.94

7.4. HIGH POWER ENHANCED DATA RATE 8PSK MODULATION

7.4.1. 20 dB AND 99% BANDWIDTH

LIMIT

None; for reporting purposes only.

TEST PROCEDURE

The transmitter output is connected to a spectrum analyzer. The RBW is set to $\geq 1\%$ of the 20 dB bandwidth. The VBW is set to \geq RBW. The sweep time is coupled.

RESULTS

Channel	Frequency (MHz)	99% Bandwidth (MHz)	20 dB Bandwidth (MHz)
Low	2402	1.2213	1.3250
Middle	2441	1.2168	1.3360
High	2480	1.2274	1.3430

99% AND 20 dB BANDWIDTH

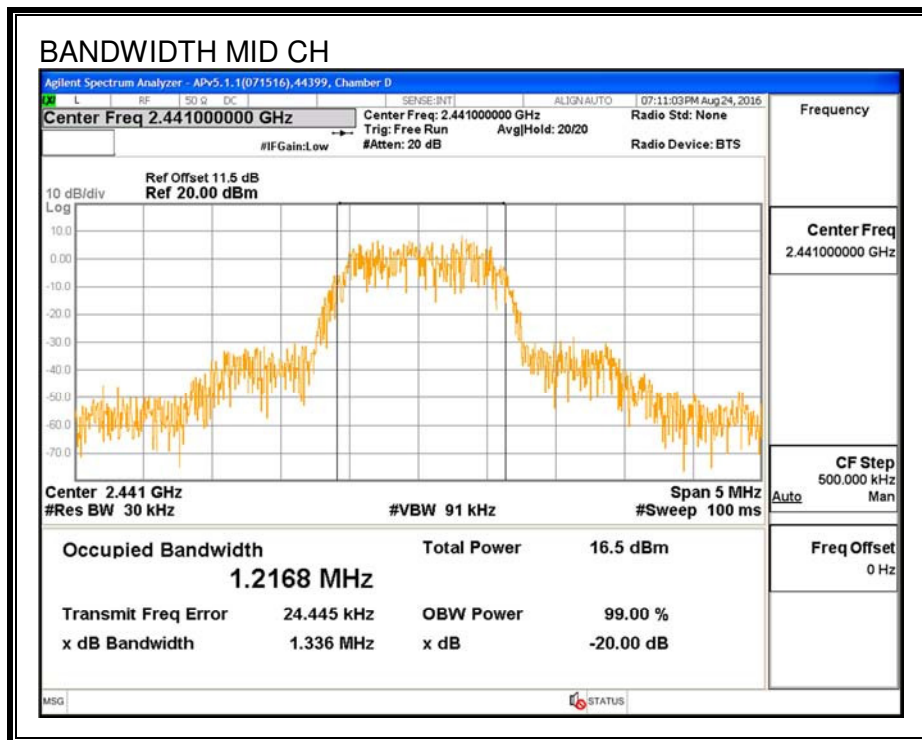
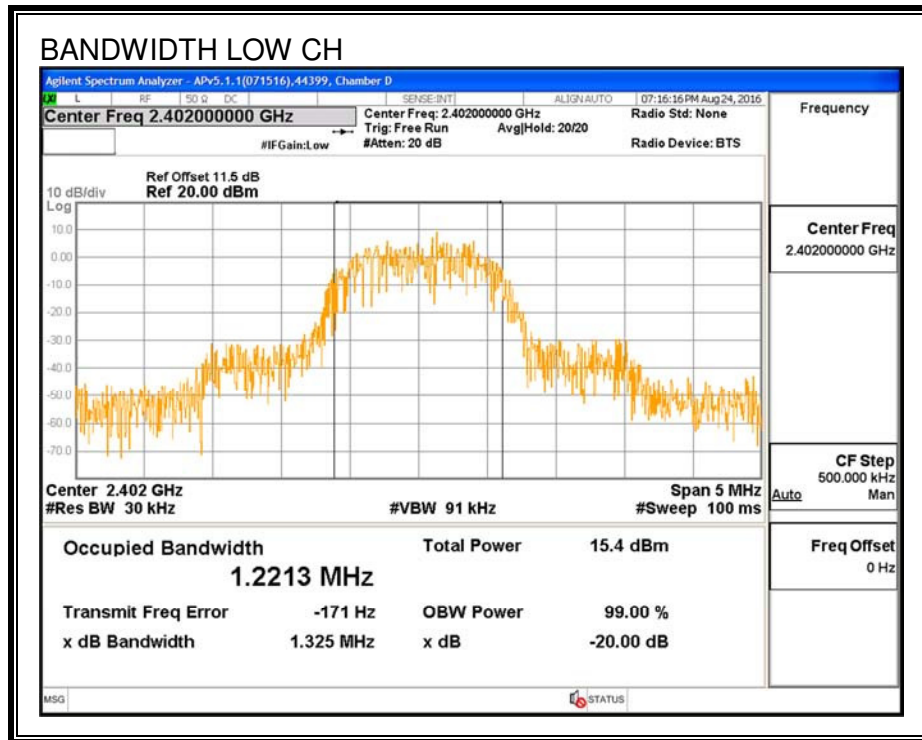

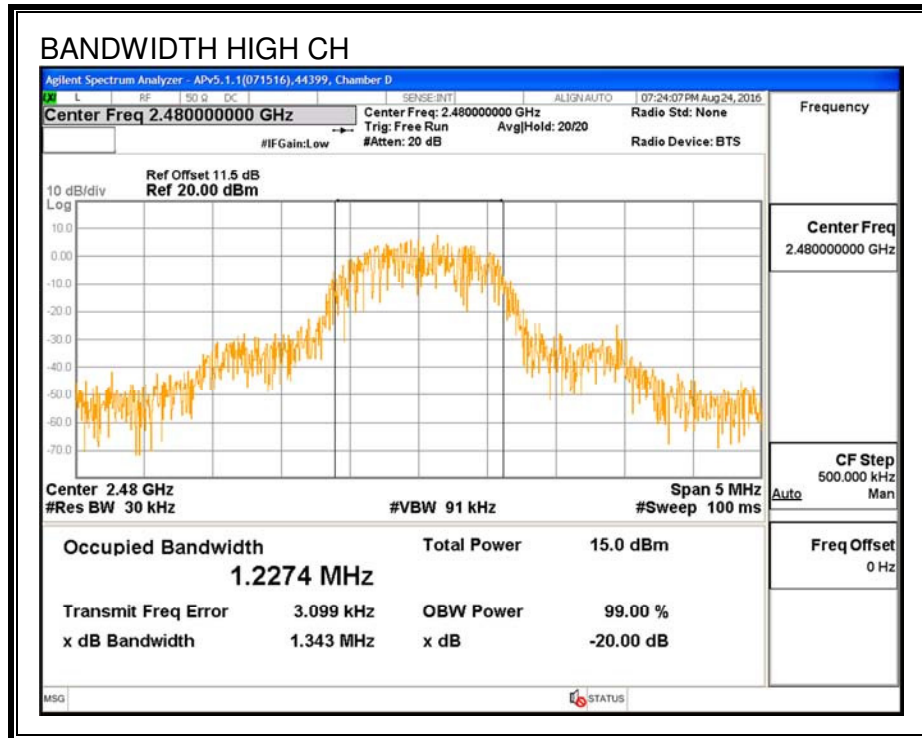

7.4.2. HOPPING FREQUENCY SEPARATION

LIMIT

FCC §15.247 (a) (1)

IC RSS-247 (5.1) (2)

Frequency hopping systems shall have hopping channel carrier frequencies separated by a minimum of 25 kHz or the 20 dB bandwidth of the hopping channel, whichever is greater.

Alternatively, frequency hopping systems operating in the 2400-2483.5 MHz band may have hopping channel carrier frequencies that are separated by 25 kHz or two-thirds of the 20 dB bandwidth of the hopping channel, whichever is greater, provided the systems operate with an output power no greater than 125 mW.

TEST PROCEDURE

The transmitter output is connected to a spectrum analyzer. The RBW is set to 300 kHz and the VBW is set to 910 kHz. The sweep time is coupled.

RESULTS

HOPPING FREQUENCY SEPARATION

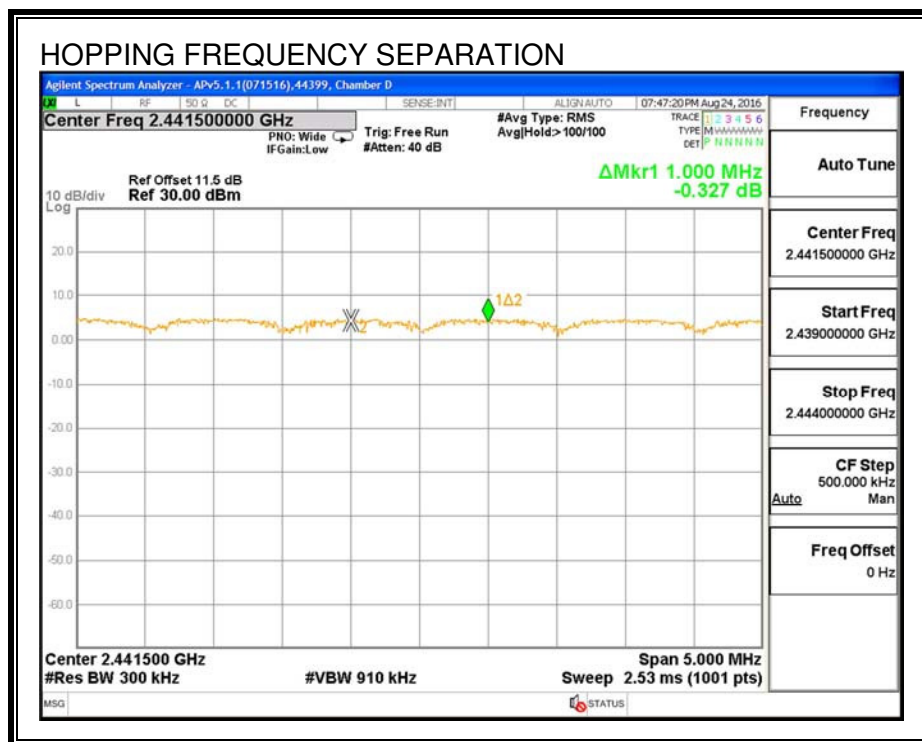

7.4.3. NUMBER OF HOPPING CHANNELS

LIMIT

FCC §15.247 (a) (1) (iii)

IC RSS-247 (5.1) (4)

Frequency hopping systems in the 2400 – 2483.5 MHz band shall use at least 15 non-overlapping channels.

TEST PROCEDURE

The transmitter output is connected to a spectrum analyzer. The span is set to cover the entire authorized band, in either a single sweep or in multiple contiguous sweeps. The RBW is set to a maximum of 1 % of the span. The analyzer is set to Max Hold.

RESULTS

Normal Mode: 79 Channels observed.

NUMBER OF HOPPING CHANNELS

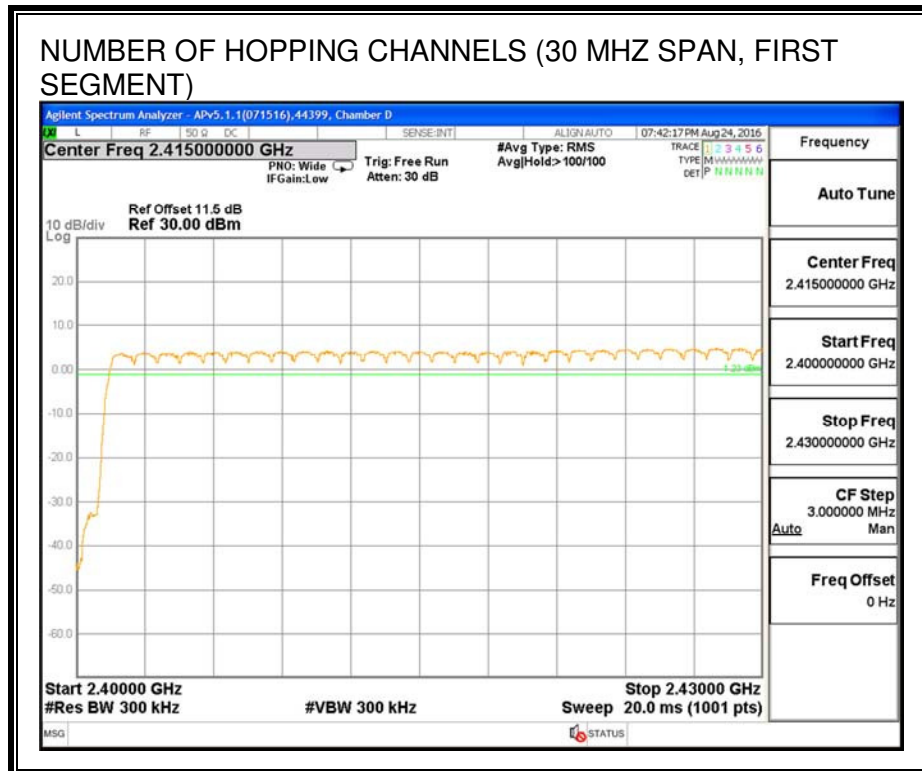
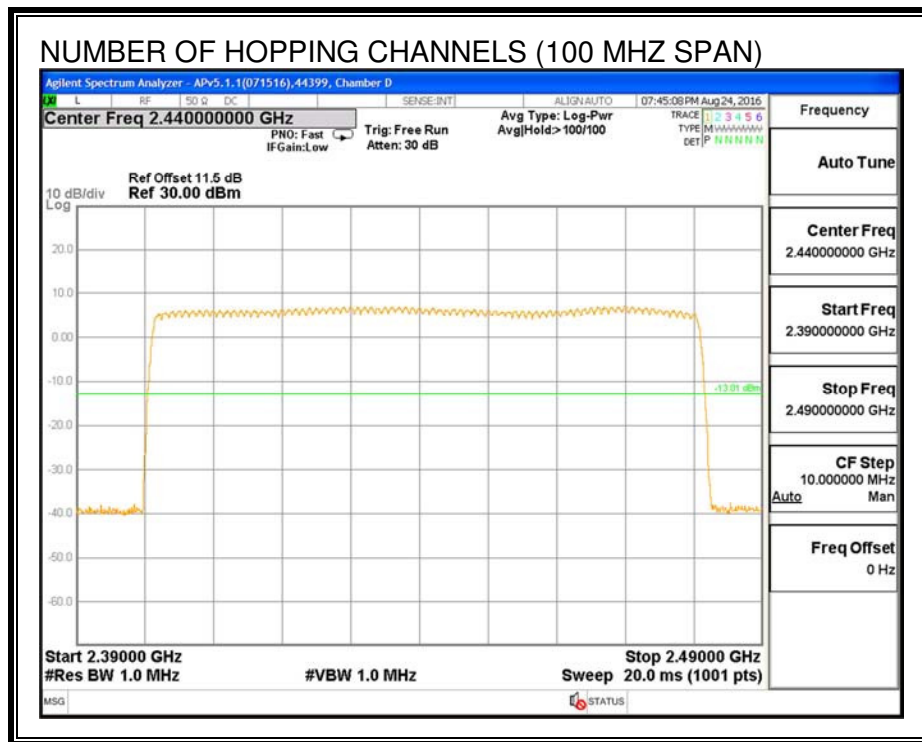

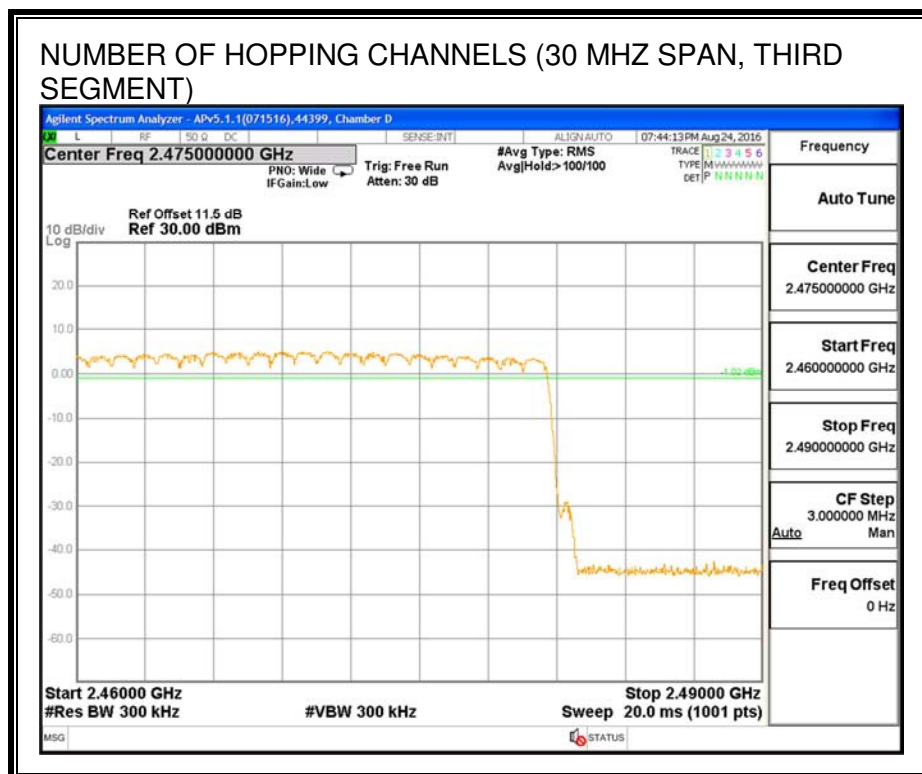
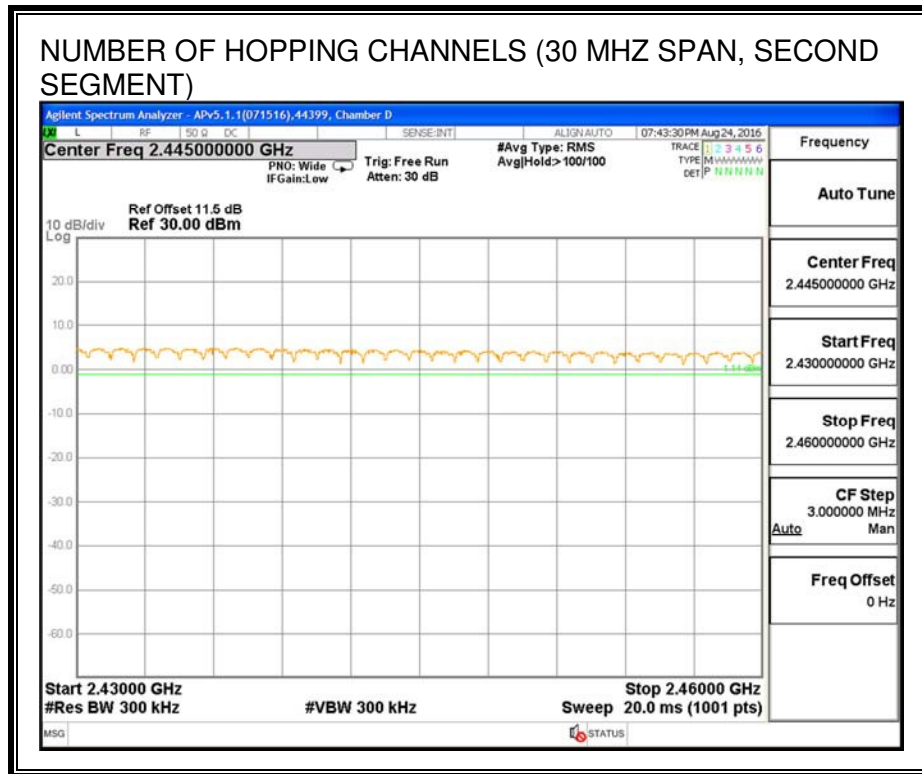

7.4.4. AVERAGE TIME OF OCCUPANCY

LIMIT

FCC §15.247 (a) (1) (iii)

IC RSS-247 (5.1) (4)

The average time of occupancy on any channel shall not be greater than 0.4 seconds within a period of 0.4 seconds multiplied by the number of hopping channels employed.

TEST PROCEDURE

The transmitter output is connected to a spectrum analyzer. The span is set to 0 Hz, centered on a single, selected hopping channel. The width of a single pulse is measured in a fast scan. The number of pulses is measured in a 3.16 second scan, to enable resolution of each occurrence.

The average time of occupancy in the specified 31.6 second period (79 channels * 0.4 s) is equal to $10 * (\# \text{ of pulses in } 3.16 \text{ s}) * \text{ pulse width}$.

RESULTS

8PSK (EDR) Mode

DH Packet	Pulse Width (msec)	Number of Pulses in 3.16 seconds	Average Time of (sec)	Limit (sec)	Margin (sec)
3DH1	0.393	32	0.126	0.4	-0.274
3DH3	1.652	17	0.281	0.4	-0.119
3DH5	2.904	13	0.378	0.4	-0.022

PULSE WIDTH - 3DH1

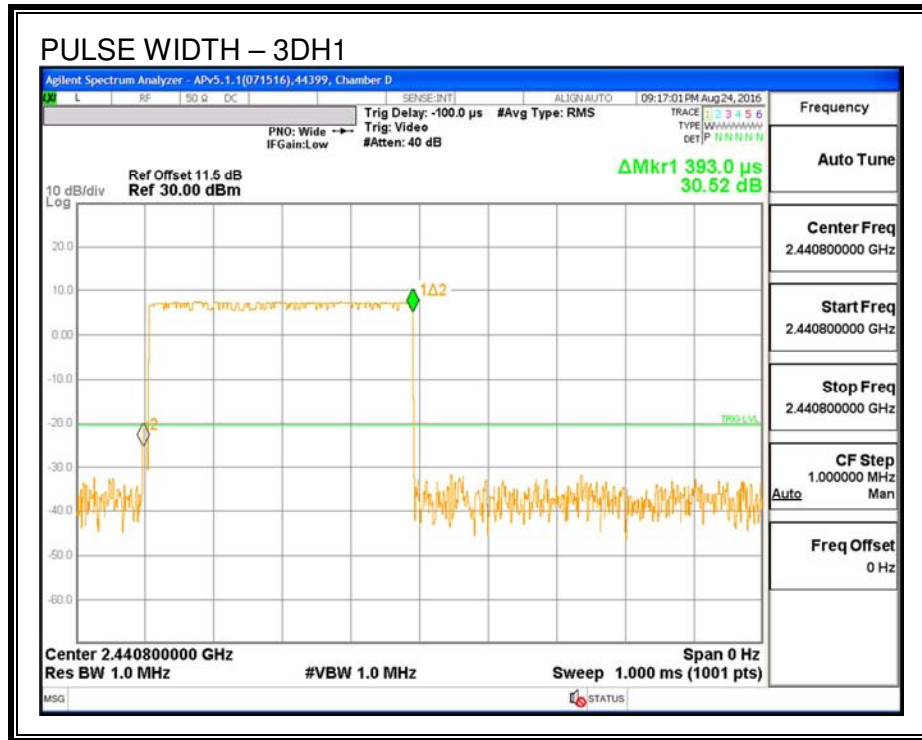

NUMBER OF PULSES IN 3.16 SECOND OBSERVATION PERIOD – 3DH1

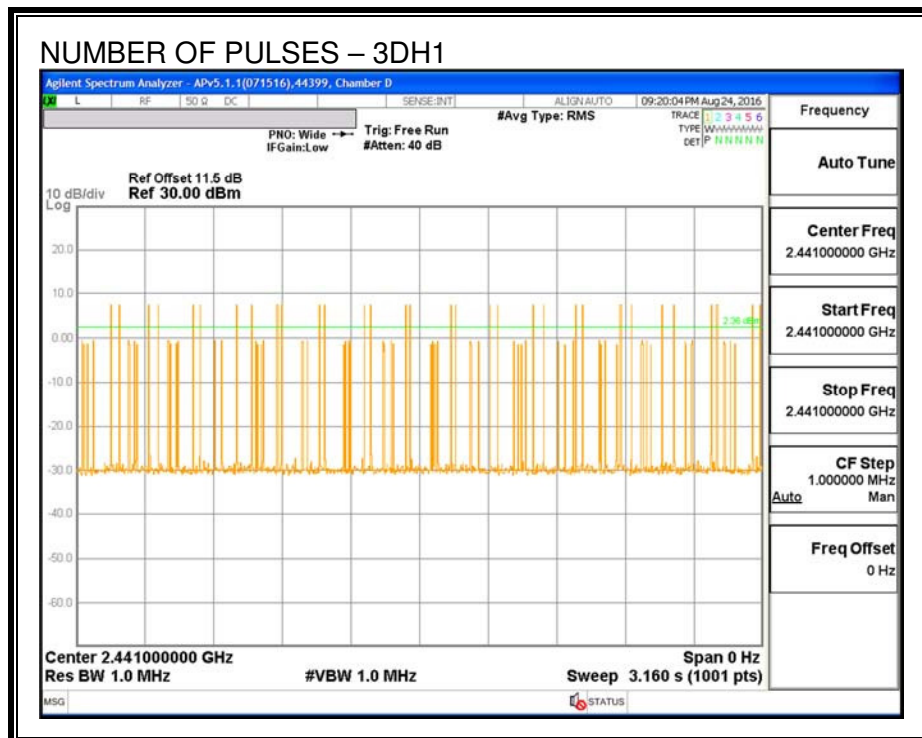

PULSE WIDTH – 3DH3

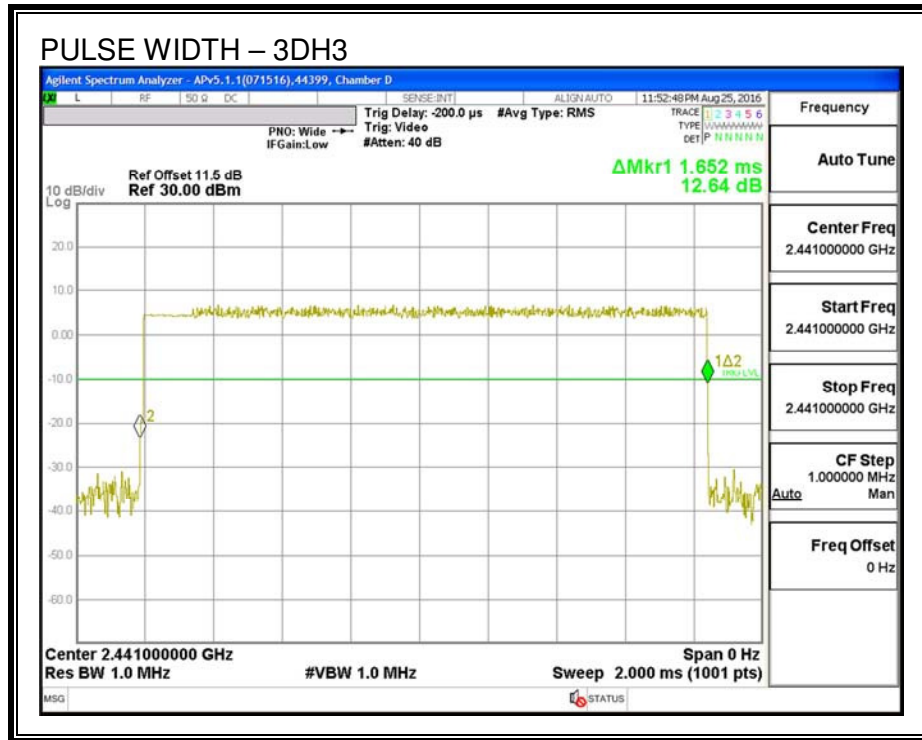

NUMBER OF PULSES IN 3.16 SECOND OBSERVATION PERIOD – 3DH3

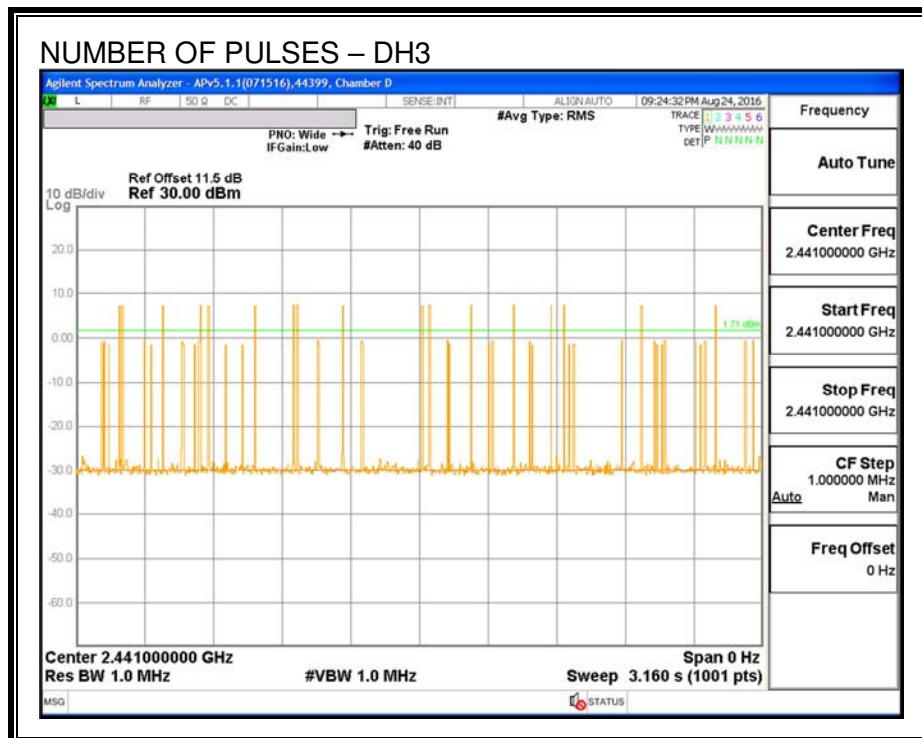

PULSE WIDTH – 3DH5

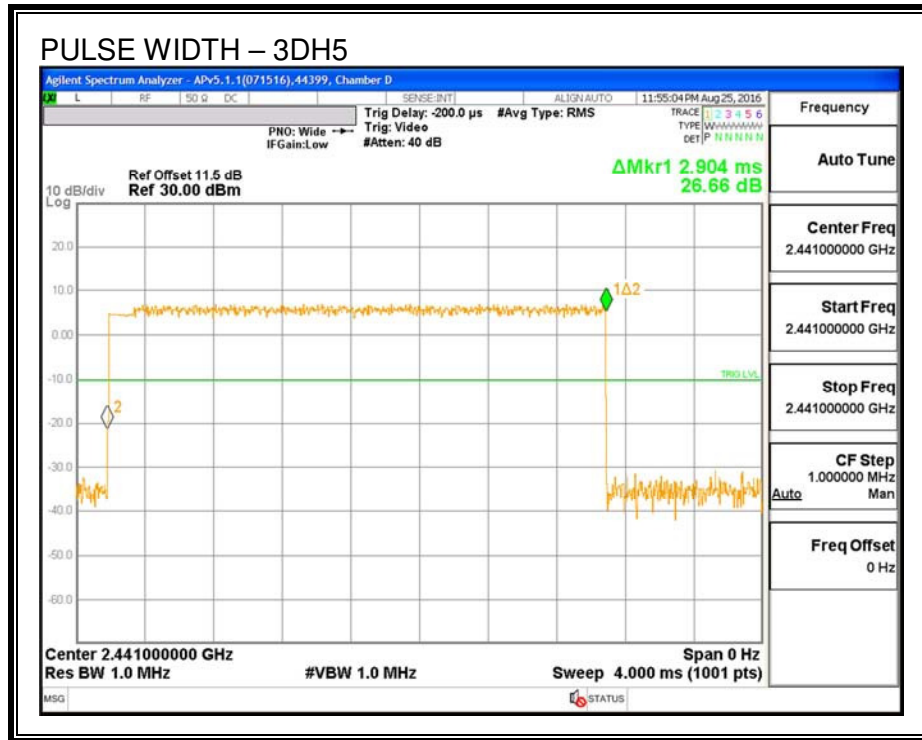

NUMBER OF PULSES IN 3.16 SECOND OBSERVATION PERIOD – 3DH5

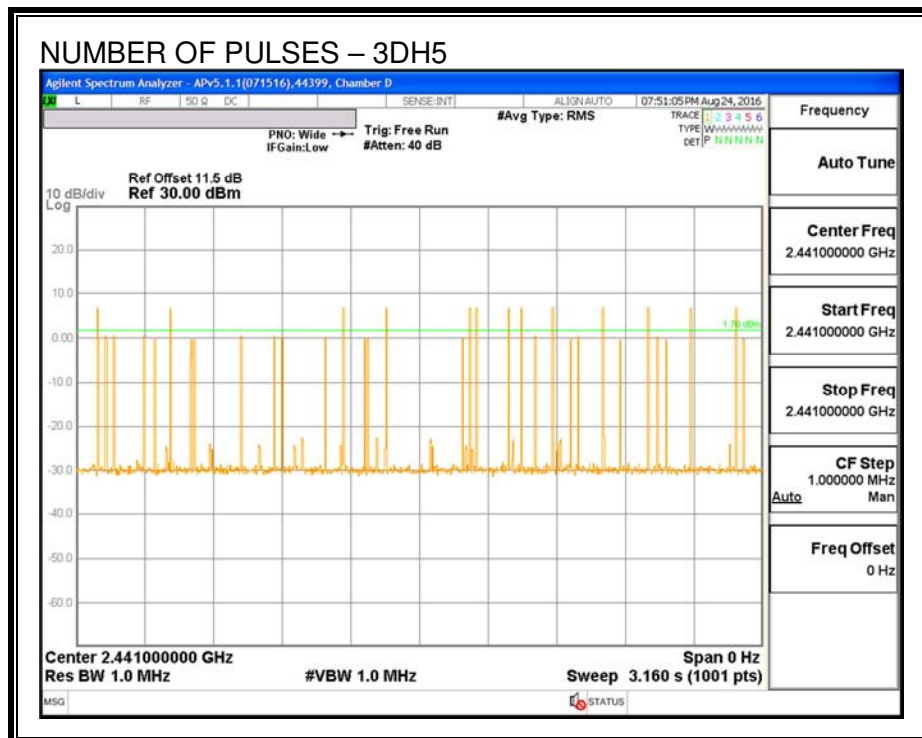

7.4.5. OUTPUT POWER

LIMIT

§15.247 (b) (1)

RSS-247 (5.4) (2)

The maximum antenna gain is less than 6 dBi, therefore the limit is 30 dBm.

Alternatively, frequency hopping systems operating in the 2400-2483.5 MHz band may have hopping channel carrier frequencies that are separated by 25 kHz or two-thirds of the 20 dB bandwidth of the hopping channel, whichever is greater, provided the systems operate with an output power no greater than 125 mW.

TEST PROCEDURE

The transmitter output is connected to a wideband peak power meter.

RESULTS

ID:	44399	Date:	8/25/16
------------	-------	--------------	---------

Channel	Frequency (MHz)	Output Power (dBm)	Limit (dBm)	Margin (dB)
Low	2402	19.44	21	-1.53
Middle	2441	19.48	21	-1.49
High	2480	19.32	21	-1.65

7.4.6. AVERAGE POWER

LIMIT

None; for reporting purposes only.

TEST PROCEDURE

The transmitter output is connected to a power meter.

RESULTS

The cable assembly insertion loss of 11 dB (including 10 dB pad and 1 dB cable) was entered as an offset in the power meter to allow for direct reading of power.

ID:	44399	Date:	8/25/16
------------	-------	--------------	---------

Channel	Frequency (MHz)	Average Power (dBm)
Low	2402	16.20
Middle	2441	16.32
High	2480	16.08

7.4.7. CONDUCTED SPURIOUS EMISSIONS

LIMITS

FCC §15.247 (d)

IC RSS-247 (5.5)

Limit = -20 dBc

TEST PROCEDURE

The transmitter output is connected to a spectrum analyzer. The resolution bandwidth is set to 100 kHz. The video bandwidth is set to 300 kHz.

The spectrum from 30 MHz to 26 GHz is investigated with the transmitter set to the lowest, middle, and highest channels.

The bandedges at 2.4 and 2.4835 GHz are investigated with the transmitter set to the normal hopping mode.

RESULTS

SPURIOUS EMISSIONS, LOW CHANNEL

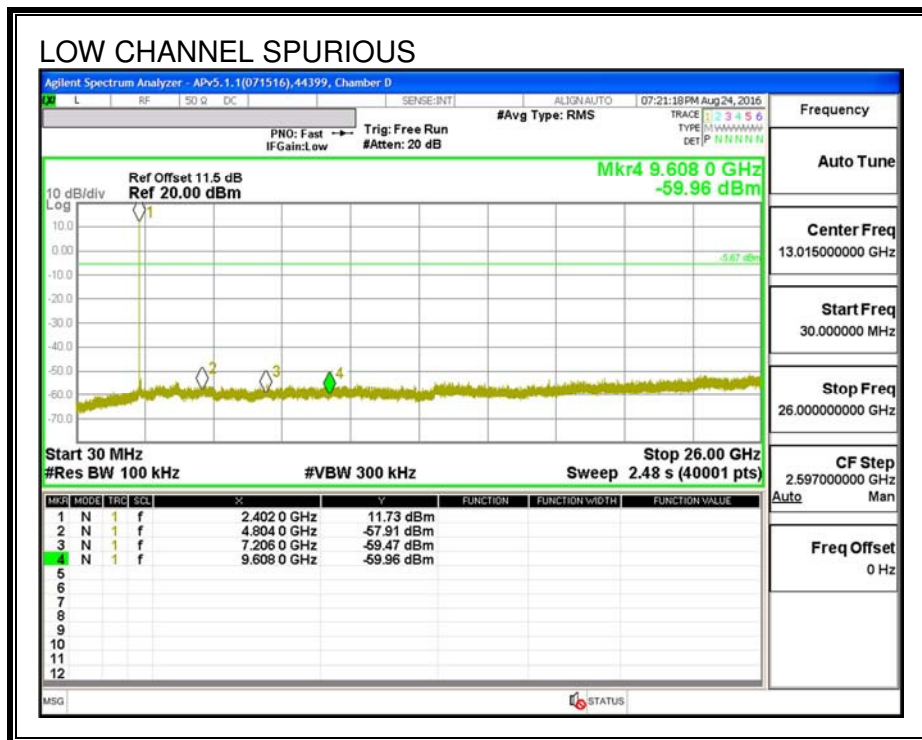
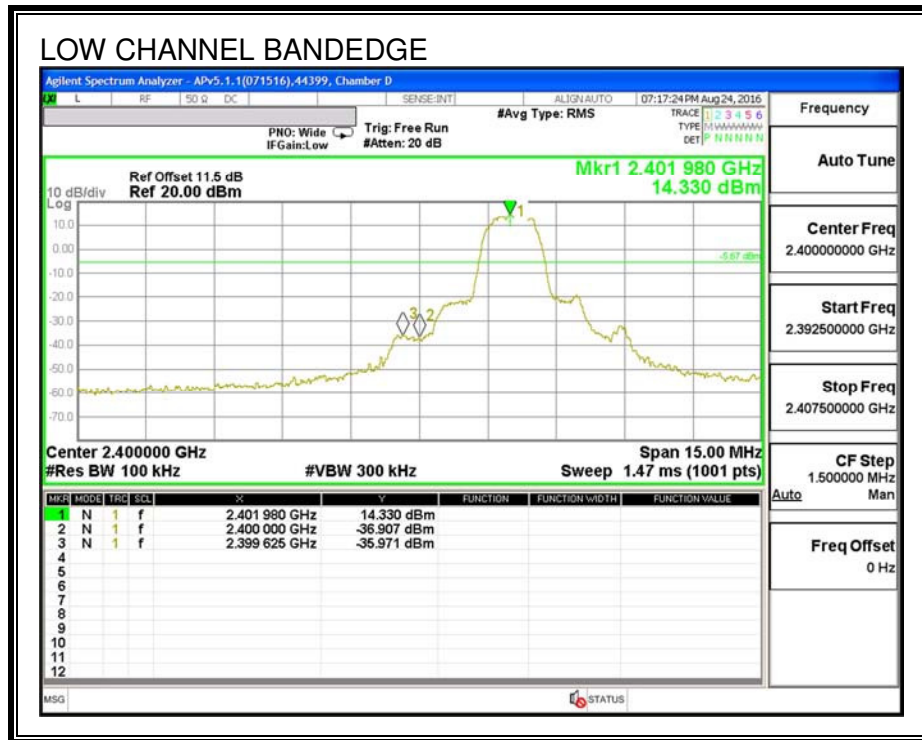

SPURIOUS EMISSIONS, MID CHANNEL

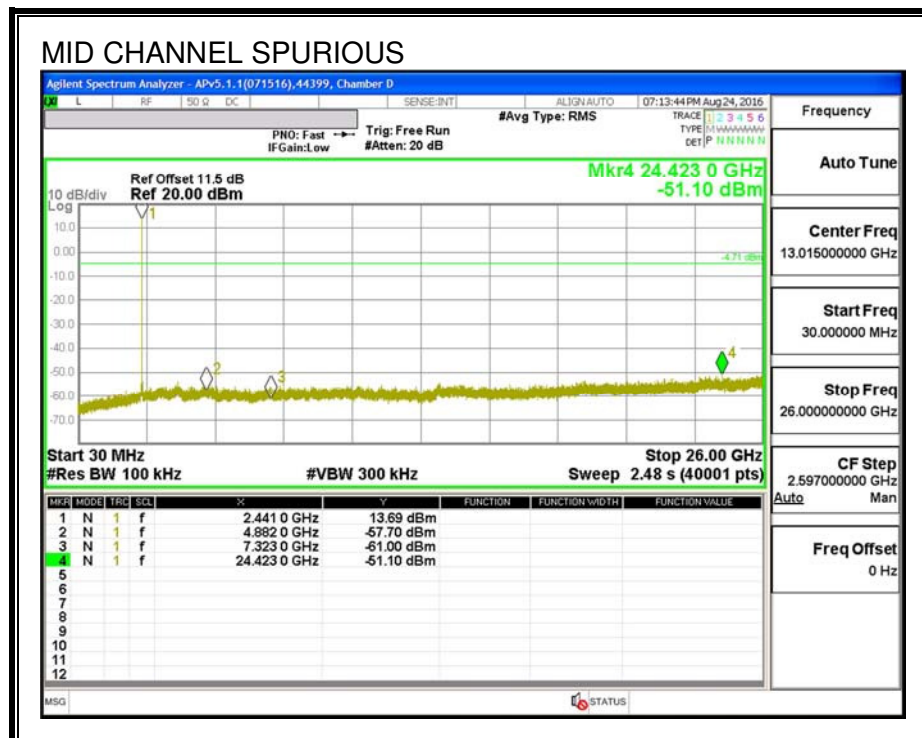
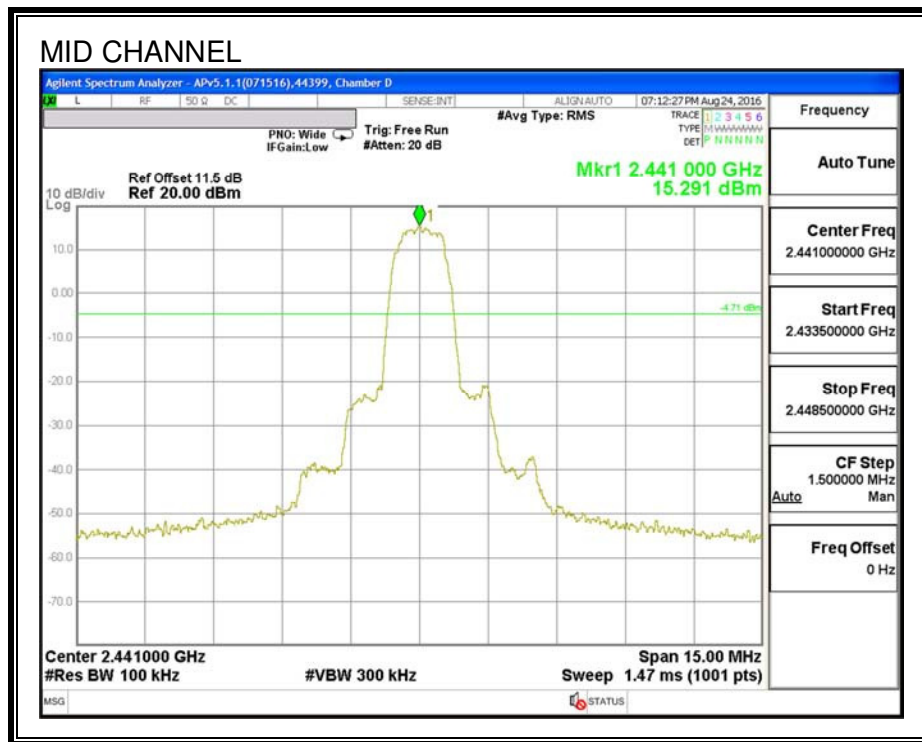

SPURIOUS EMISSIONS, HIGH CHANNEL

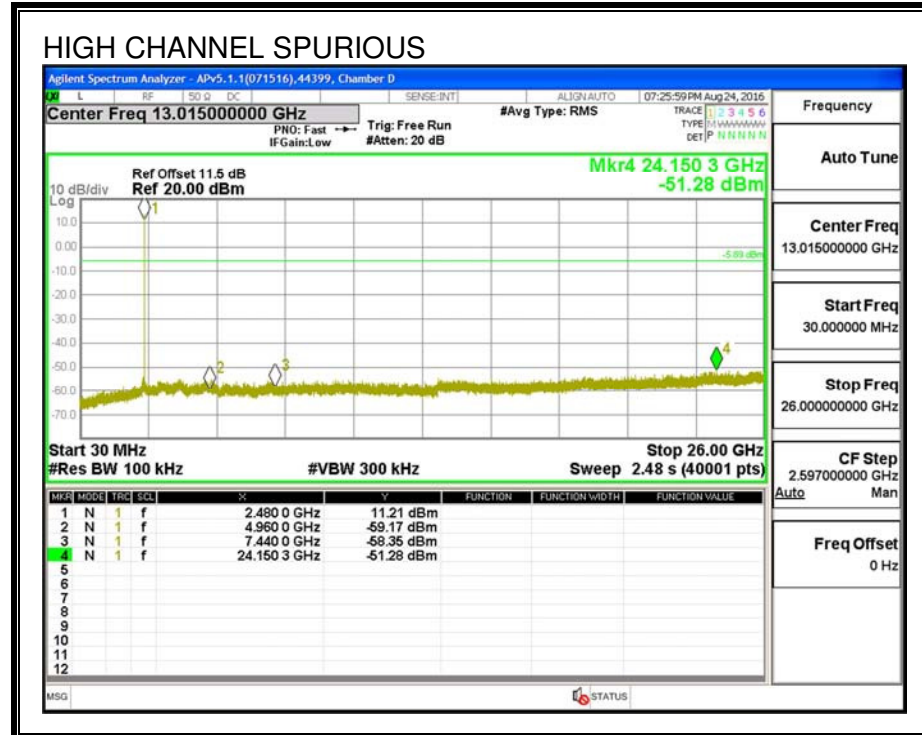
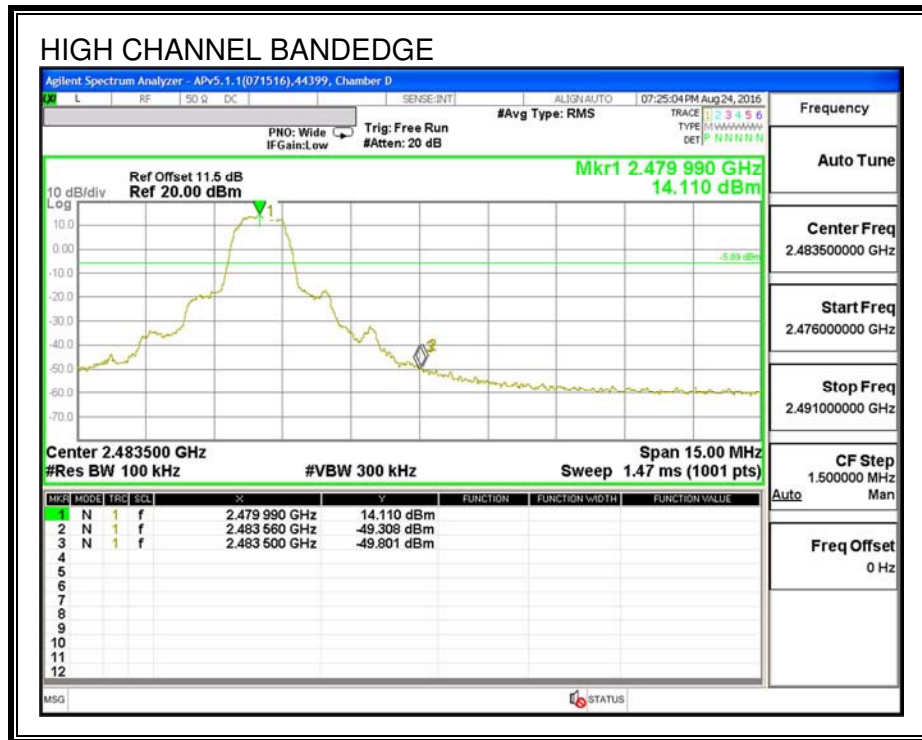

SPURIOUS BANDEGE EMISSIONS WITH HOPPING ON

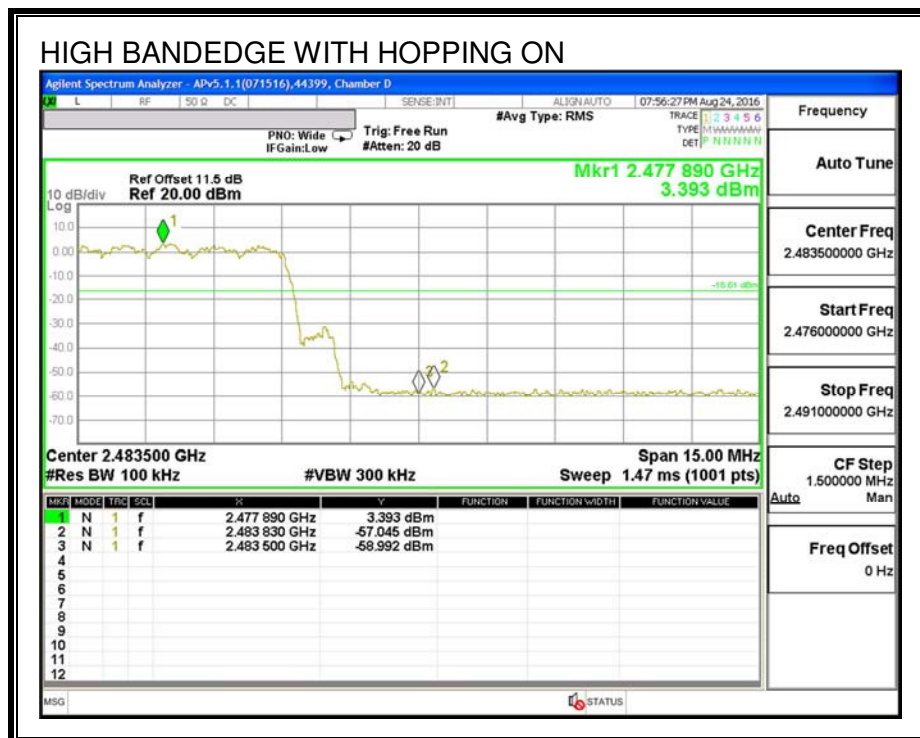
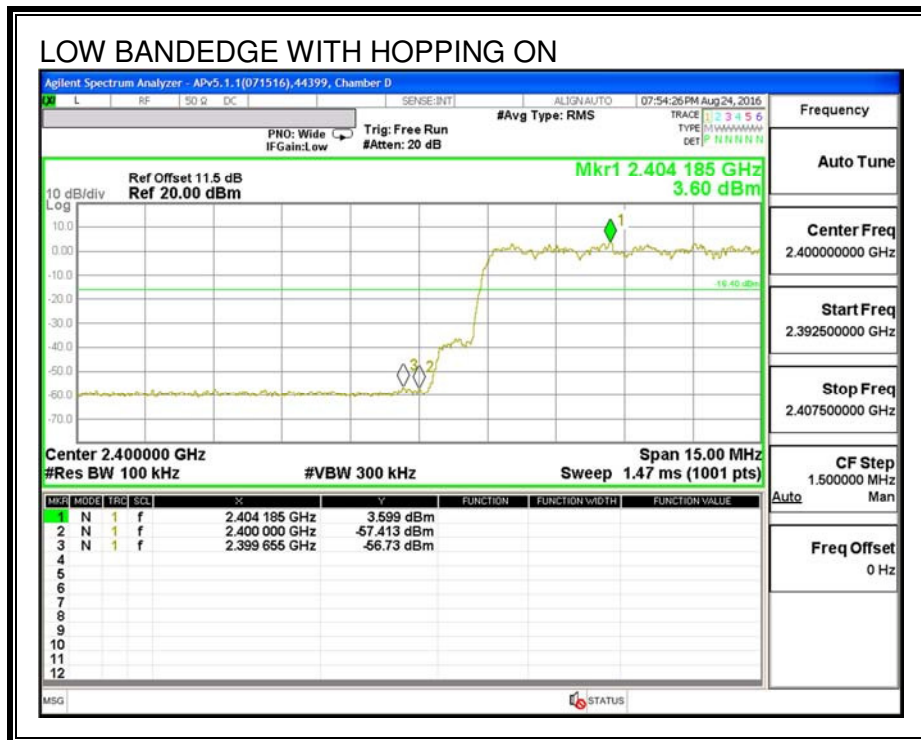

8. RADIATED TEST RESULTS

8.1. LIMITS AND PROCEDURE

LIMITS

FCC §15.205 and §15.209

IC RSS-GEN, Section 8.9 and 8.10.

Frequency Range (MHz)	Field Strength Limit (uV/m) at 3 m	Field Strength Limit (dBuV/m) at 3 m
30 - 88	100	40
88 - 216	150	43.5
216 - 960	200	46
Above 960	500	54

TEST PROCEDURE

The EUT is placed on a non-conducting table 80 cm above the ground plane for measurement below 1GHz; 1.5 m above the ground plane for measurement above 1GHz. The antenna to EUT distance is 3 meters. The EUT is configured in accordance with ANSI C63.10. The EUT is set to transmit in a continuous mode.

For measurements below 1 GHz the resolution bandwidth is set to 100 kHz for peak detection measurements or 120 kHz for quasi-peak detection measurements. Peak detection is used unless otherwise noted as quasi-peak.

For measurements above 1 GHz the resolution bandwidth is set to 1 MHz, then the video bandwidth is set to 3 MHz for peak measurements and 1 MHz resolution bandwidth with 1/T (10 Hz) video bandwidth with peak detector for average measurements.

For harmonics and Spurious Emission", the setting is RBW/VBW = 1 MHz/30kHz for pre-test before the final testing

The spectrum from 30 MHz to 26 GHz is investigated with the transmitter set to the lowest, middle, and highest channels in the 2.4 GHz band.

The frequency range of interest is monitored at a fixed antenna height and EUT azimuth. The EUT is rotated through 360 degrees to maximize emissions received. The antenna is scanned from 1 to 4 meters above the ground plane to further maximize the emission. Measurements are made with the antenna polarized in both the vertical and the horizontal positions.

RESULTS

8.2. TRANSMITTER ABOVE 1 GHz

8.2.1. HIGH POWER BASIC DATA RATE GFSK MODULATION

RESTRICTED BANDEDGE (LOW CHANNEL, HORIZONTAL)

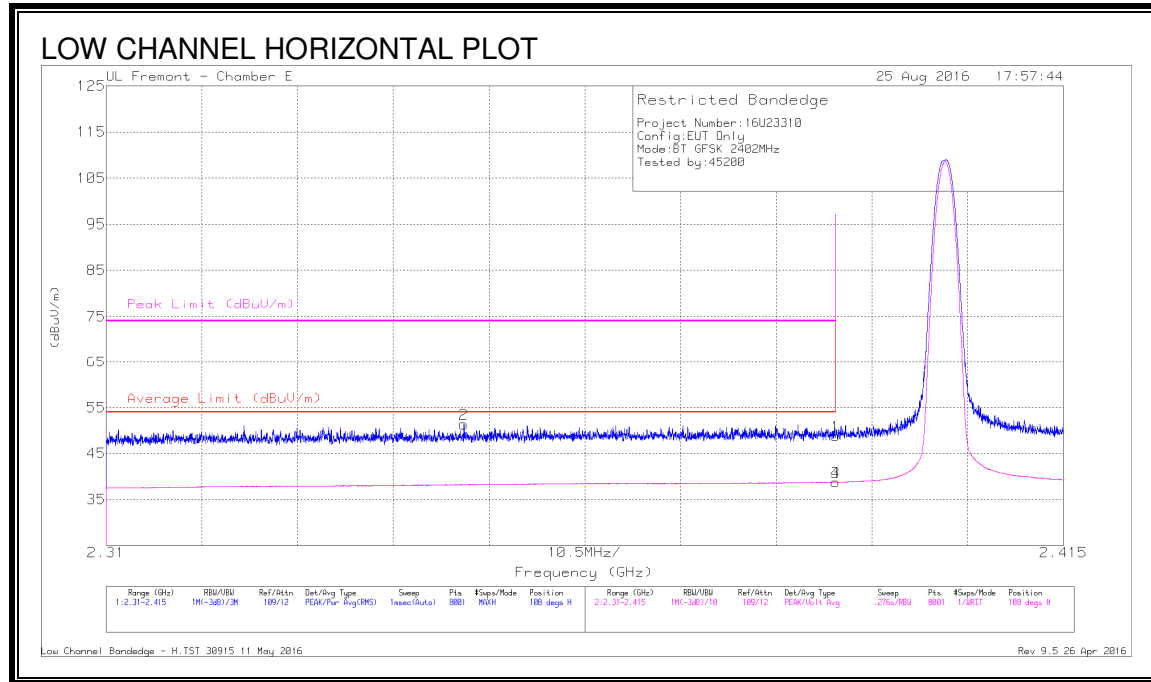

DATA

Marker	Frequency (GHz)	Meter Reading (dBuV)	Det	AF T711 (dB/m)	Amp/Cbl/Fit r/Pad (dB)	Corrected Reading (dBuV/m)	Average Limit (dBuV/m)	Margin (dB)	Peak Limit (dBuV/m)	PK Margin (dB)	Azimuth (Degs)	Height (cm)	Polarity
2	* 2.349	39.65	Pk	31.8	-20.1	51.35	-	-	74	-22.65	108	131	H
1	* 2.39	36.61	Pk	32.1	-19.9	48.81	-	-	74	-25.19	108	131	H
3	* 2.39	26.54	VA1T	32.1	-19.9	38.74	54	-15.26	-	-	108	131	H
4	* 2.39	26.55	VA1T	32.1	-19.9	38.75	54	-15.25	-	-	108	131	H

* - indicates frequency in CFR47 Pt 15 / IC RSS-Restricted Band

Pk - Peak detector

VA1T - FHSS: Linear Voltage Average VB=1/Ton where: Ton is transmit duration

RESTRICTED BANDEDGE (LOW CHANNEL, VERTICAL)

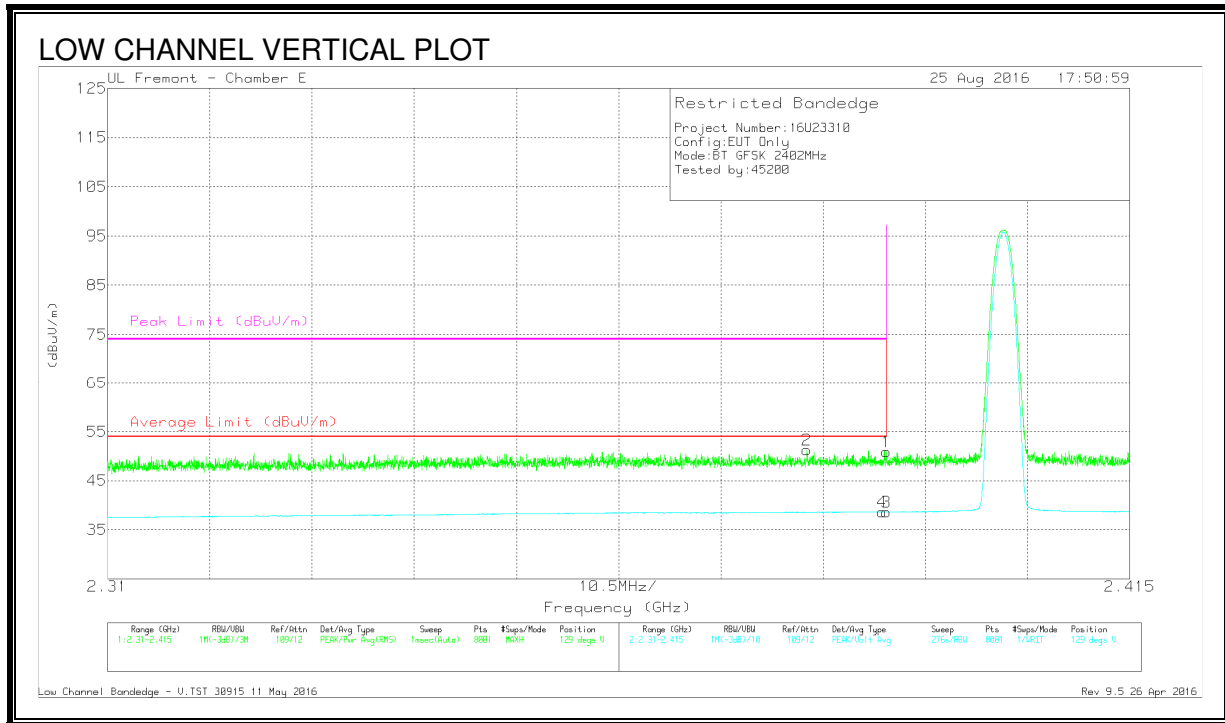

DATA

Marker	Frequency (GHz)	Meter Reading (dBuV)	Det	AF T711 (dB/m)	Amp/Cbl/Fit r/Pad (dB)	Corrected Reading (dBuV/m)	Average Limit (dBuV/m)	Margin (dB)	Peak Limit (dBuV/m)	PK Margin (dB)	Azimuth (Degs)	Height (cm)	Polarity
1	* 2.39	38.66	Pk	32.1	-19.9	50.86	-	-	74	-23.14	129	260	V
2	* 2.382	39.18	Pk	32	-19.9	51.28	-	-	74	-22.72	129	260	V
3	* 2.39	26.41	VA1T	32.1	-19.9	38.61	54	-15.39	-	-	129	260	V
4	* 2.39	26.46	VA1T	32.1	-19.9	38.66	54	-15.34	-	-	129	260	V

* - indicates frequency in CFR47 Pt 15 / IC RSS-Restricted Band

Pk - Peak detector

VA1T - FHSS: Linear Voltage Average VB=1/Ton where: Ton is transmit duration

RESTRICTED BANDEDGE (HIGH CHANNEL, HORIZONTAL)

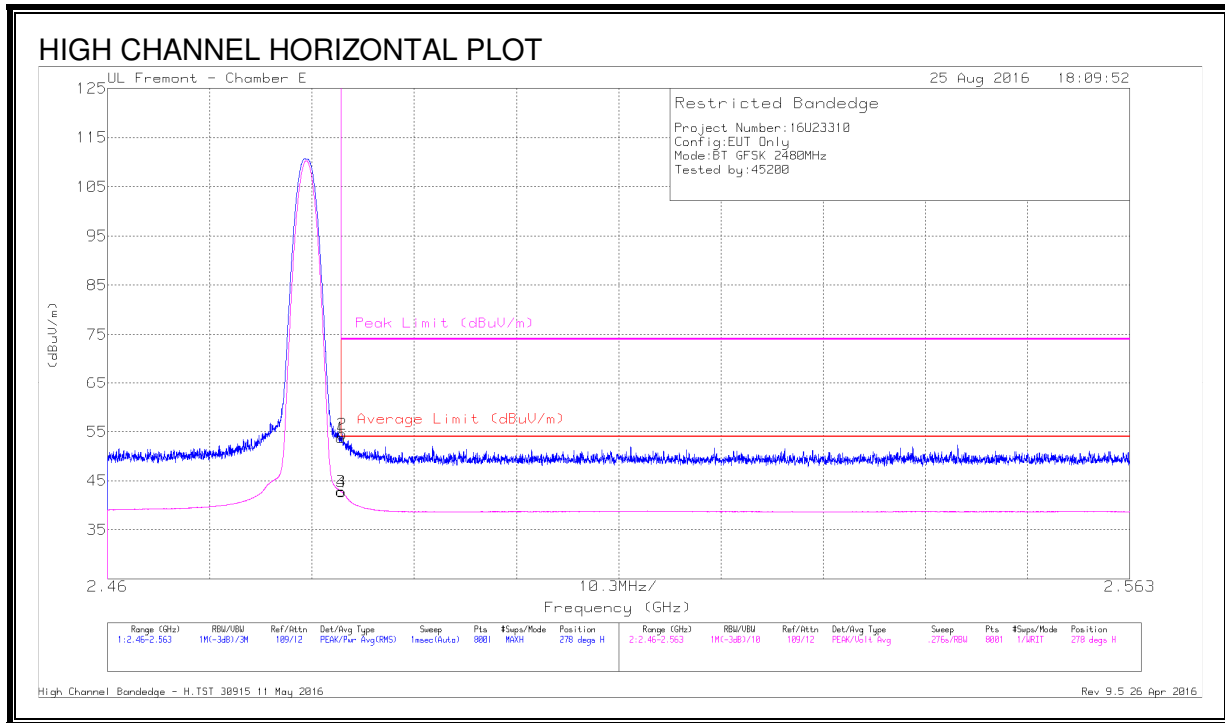

DATA

Marker	Frequency (GHz)	Meter Reading (dBuV)	Det	AF T711 (dB/m)	Amp/Cbl/Fitr/Pad (dB)	Corrected Reading (dBuV/m)	Average Limit (dBuV/m)	Margin (dB)	Peak Limit (dBuV/m)	PK Margin (dB)	Azimuth (Degs)	Height (cm)	Polarity
1	* 2.484	41.5	Pk	32.3	-20	53.8	-	-	74	-20.2	278	108	H
2	* 2.484	42.22	Pk	32.3	-20	54.52	-	-	74	-19.48	278	108	H
3	* 2.484	30.53	VA1T	32.3	-20	42.83	54	-11.17	-	-	278	108	H
4	* 2.484	30.42	VA1T	32.3	-20	42.72	54	-11.28	-	-	278	108	H

* - indicates frequency in CFR47 Pt 15 / IC RSS-Restricted Band

Pk - Peak detector

VA1T - FHSS: Linear Voltage Average VB=1/Ton where: Ton is transmit duration

RESTRICTED BANDEGE (HIGH CHANNEL, VERTICAL)

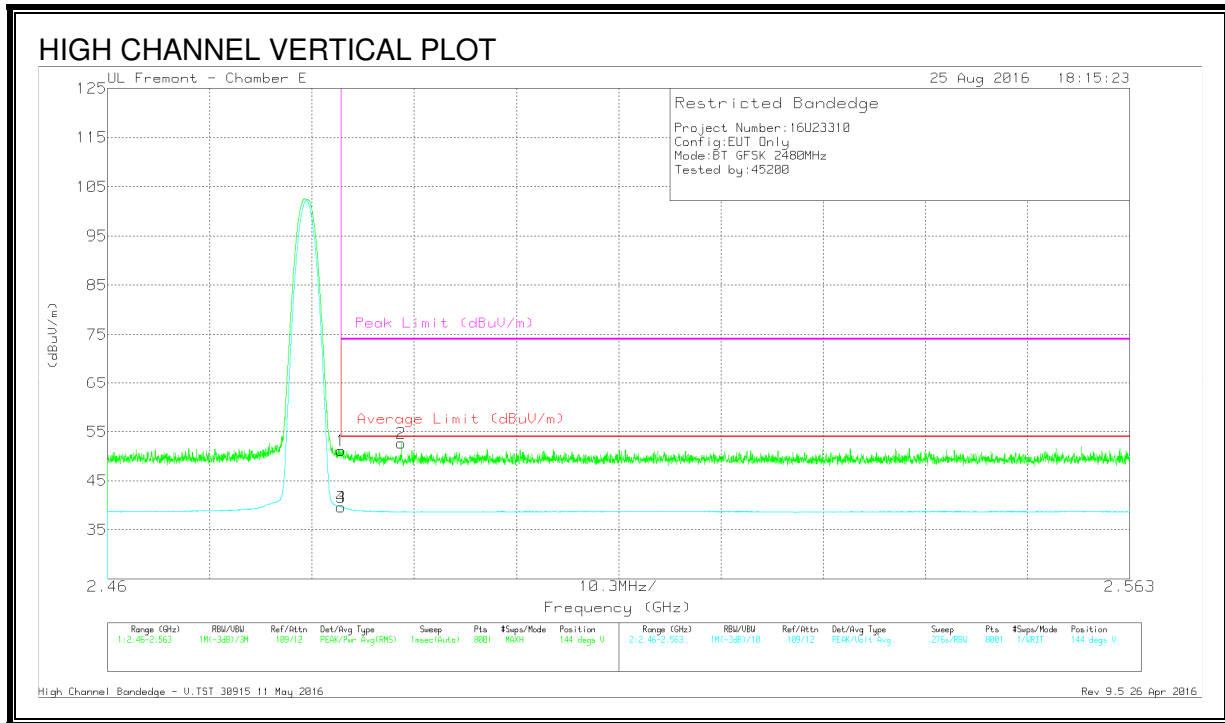

DATA

Marker	Frequency (GHz)	Meter Reading (dBuV)	Det	AF T711 (dB/m)	Amp/Cbl/Fit r/Pad (dB)	Corrected Reading (dBuV/m)	Average Limit (dBuV/m)	Margin (dB)	Peak Limit (dBuV/m)	PK Margin (dB)	Azimuth (Degs)	Height (cm)	Polarity
1	* 2.484	38.85	Pk	32.3	-20	51.15	-	-	74	-22.85	144	356	V
3	* 2.484	27.33	VA1T	32.3	-20	39.63	54	-14.37	-	-	144	356	V
4	* 2.484	27.34	VA1T	32.3	-20	39.64	54	-14.36	-	-	144	356	V
2	* 2.49	40.41	Pk	32.3	-20.1	52.61	-	-	74	-21.39	144	356	V

* - indicates frequency in CFR47 Pt 15 / IC RSS-Restricted Band

Pk - Peak detector

VA1T - FHSS: Linear Voltage Average VB=1/Ton where: Ton is transmit duration

HARMONICS AND SPURIOUS EMISSIONS

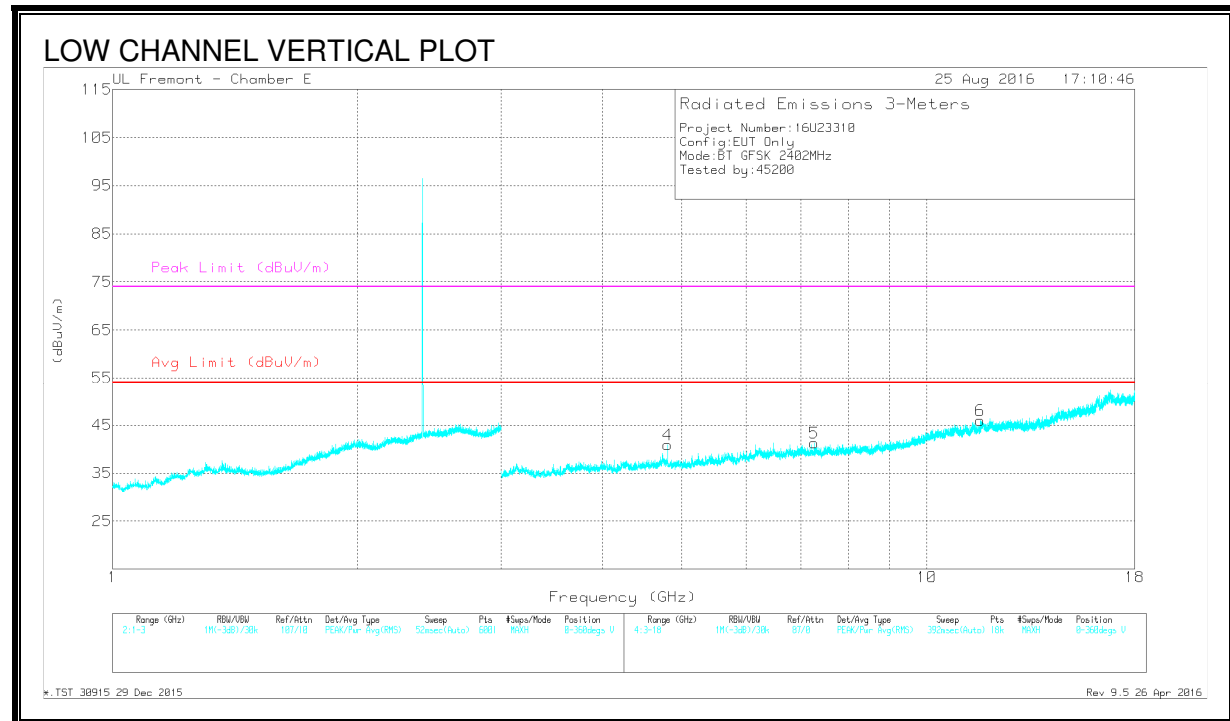
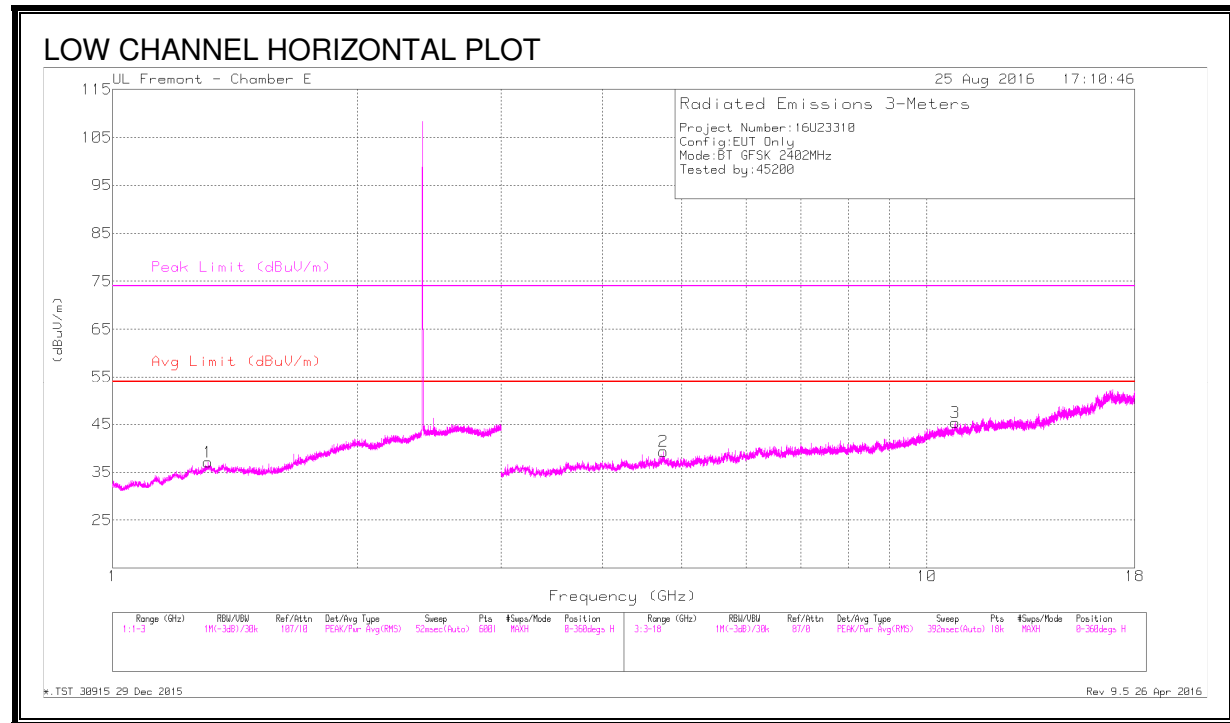

DATA

Marker	Frequenc y (GHz)	Meter Readin g (dBuV)	Det	AF T711 (dB/m)	Amp/Cbl/Filtr/ Pad (dB)	Correcte d Reading (dBuV/m)	Avg Limit (dBuV/m)	Margin (dB)	Peak Limit (dBuV/m)	PK Margin (dB)	Azimet h (Degs)	Height (cm)	Polarit y
1	* 1.31	34.96	PKFH	29.3	-22.4	41.86	-	-	74	-32.14	125	144	H
	* 1.308	24.11	VA1T	29.3	-22.4	31.01	54	-22.99	-	-	125	144	H
2	* 4.742	39.04	PKFH	34	-29.1	43.94	-	-	74	-30.06	114	240	H
	* 4.742	27.91	VA1T	34	-29.1	32.81	54	-21.19	-	-	114	240	H
3	* 10.833	36.28	PKFH	37.9	-22.7	51.48	-	-	74	-22.52	325	378	H
	* 10.833	24.18	VA1T	37.9	-22.7	39.38	54	-14.62	-	-	325	378	H
4	* 4.804	42.37	PKFH	34	-29.8	46.57	-	-	74	-27.43	40	307	V
	* 4.804	34.68	VA1T	34	-29.8	38.88	54	-15.12	-	-	40	307	V
5	* 7.277	36.9	PKFH	35.6	-26.7	45.8	-	-	74	-28.2	44	160	V
	* 7.277	25.44	VA1T	35.6	-26.7	34.34	54	-19.66	-	-	44	160	V
6	* 11.629	37.2	PKFH	38.5	-23.7	52	-	-	74	-22	270	110	V
	* 11.626	24.56	VA1T	38.5	-23.7	39.36	54	-14.64	-	-	270	110	V

* - indicates frequency in CFR47 Pt 15 / IC RSS-Restricted Band

PKFH - FHSS: RB=100k/1MHz VB=3 x RB, Peak

VA1T - FHSS: Linear Voltage Average VB=1/Ton where: Ton is transmit duration

HARMONICS AND SPURIOUS EMISSIONS

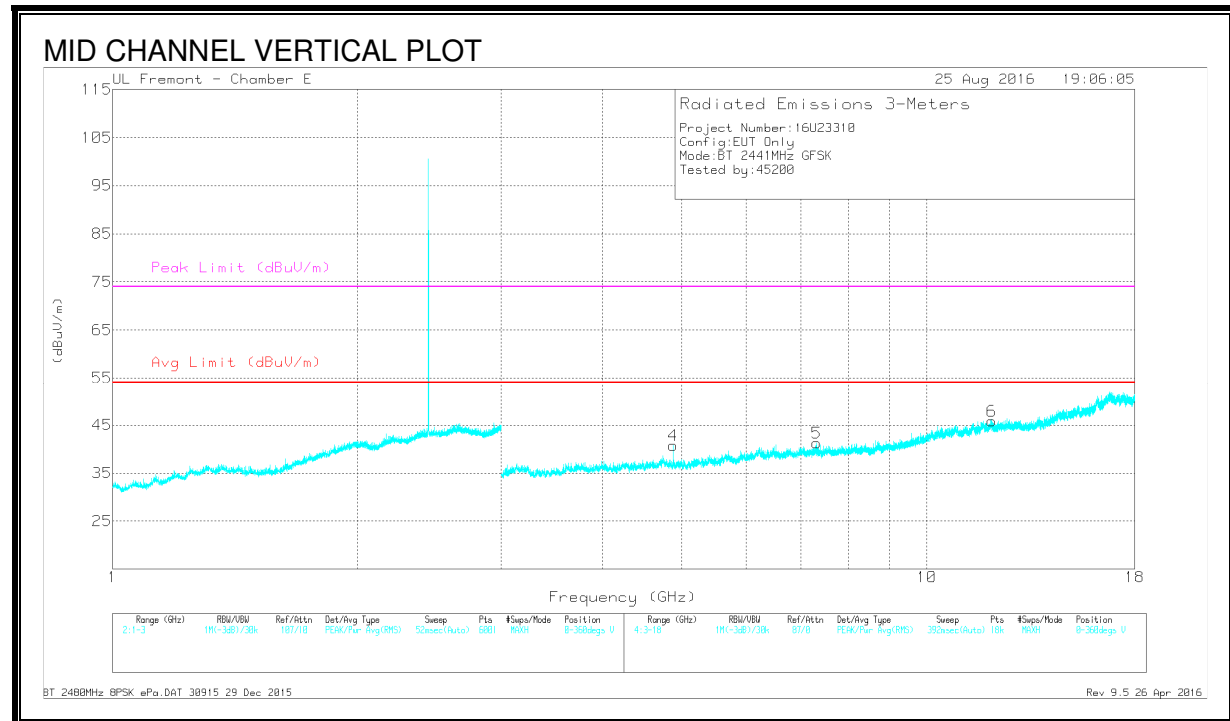
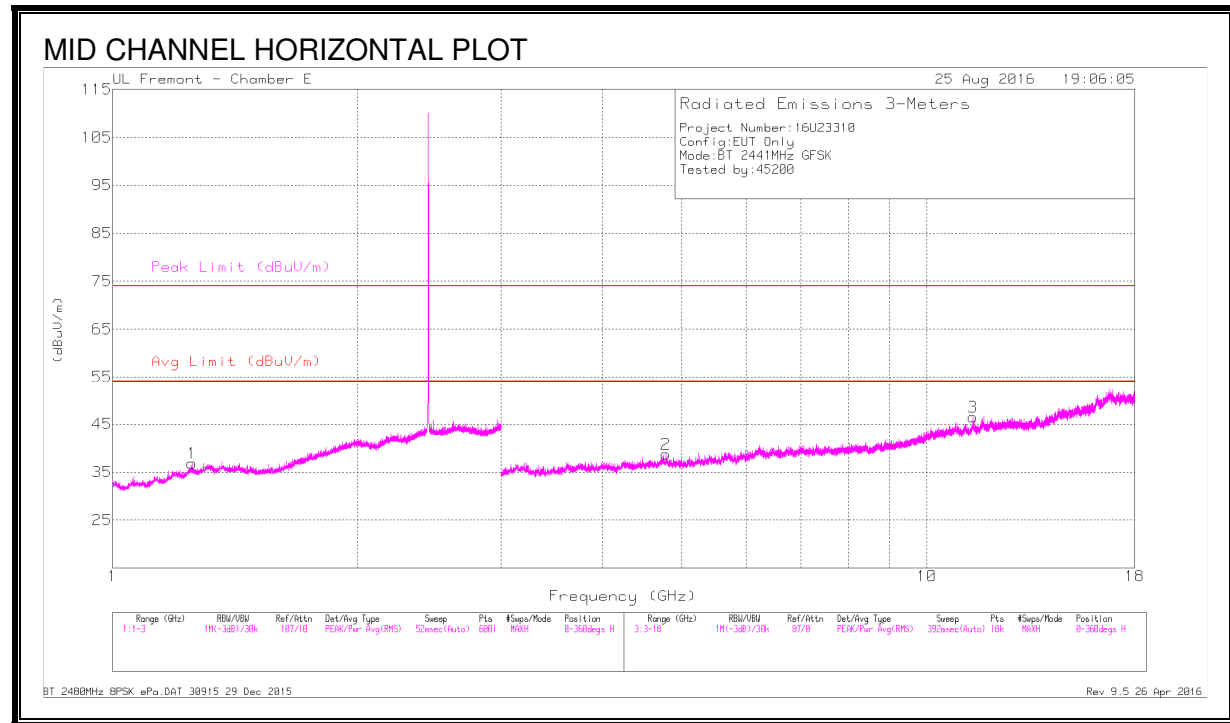

DATA

Markers	Frequenc y (GHz)	Meter Readin g (dBuV)	Det	AF T711 (dB/m)	Amp/Cbl/Filtr/ Pad (dB)	Correcte d Reading (dBuV/m)	Avg Limit (dBuV/m)	Margin (dB)	Peak Limit (dBuV/m)	PK Margin (dB)	Azimet h (Degs)	Height (cm)	Polarit y
1	* 1.25	35.35	PKFH	28.9	-22.6	41.65	-	-	74	-32.35	236	363	H
	* 1.25	24.1	VA1T	28.9	-22.6	30.4	54	-23.6	-	-	236	363	H
2	* 4.783	38.83	PKFH	34	-29.4	43.43	-	-	74	-30.57	301	201	H
	* 4.783	27.62	VA1T	34	-29.4	32.22	54	-21.78	-	-	301	201	H
3	* 11.398	35.62	PKFH	38.2	-22	51.82	-	-	74	-22.18	175	351	H
	* 11.396	24	VA1T	38.2	-22.1	40.1	54	-13.9	-	-	175	351	H
4	* 4.882	42.33	PKFH	34	-30.4	45.93	-	-	74	-28.07	47	317	V
	* 4.882	34.64	VA1T	34	-30.4	38.24	54	-15.76	-	-	47	317	V
5	* 7.324	38.07	PKFH	35.6	-26.3	47.37	-	-	74	-26.63	238	313	V
	* 7.323	28.23	VA1T	35.6	-26.2	37.63	54	-16.37	-	-	238	313	V
6	* 12.018	36.14	PKFH	38.9	-23.6	51.44	-	-	74	-22.56	62	218	V
	* 12.018	24.84	VA1T	38.9	-23.6	40.14	54	-13.86	-	-	62	218	V

* - indicates frequency in CFR47 Pt 15 / IC RSS-Restricted Band

PKFH - FHSS: RB=100k/1MHz VB=3 x RB, Peak

VA1T - FHSS: Linear Voltage Average VB=1/Ton where: Ton is transmit duration

HARMONICS AND SPURIOUS EMISSIONS

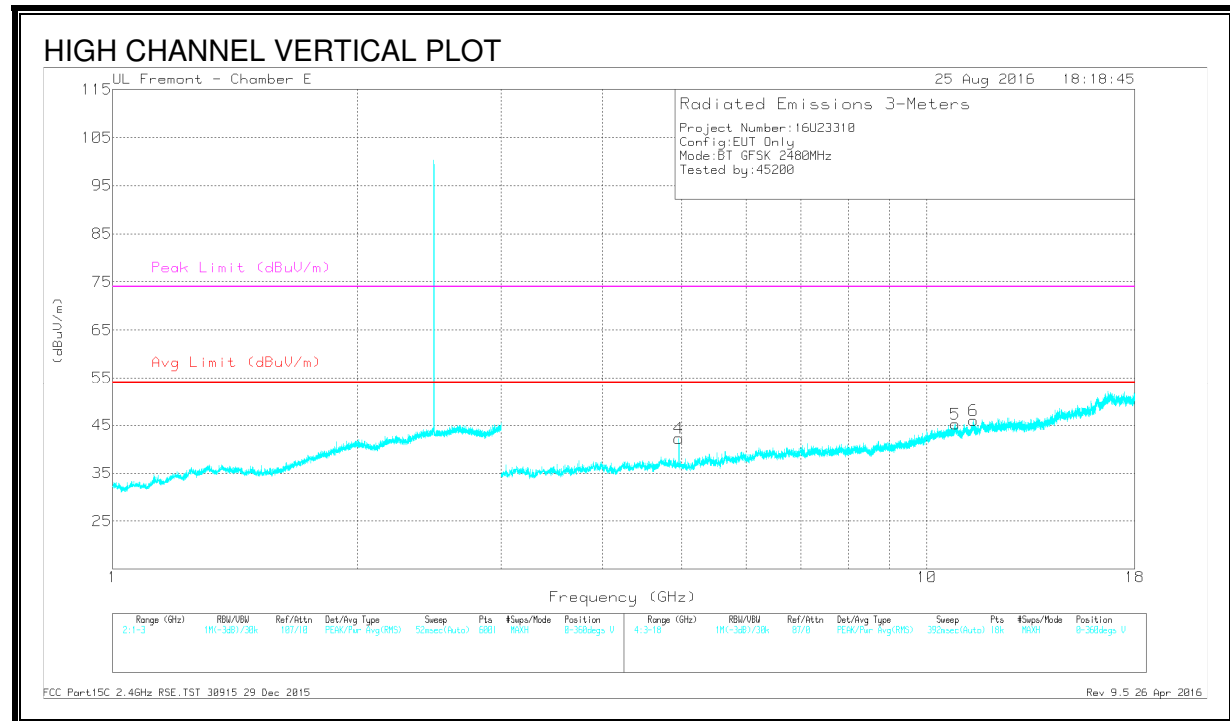
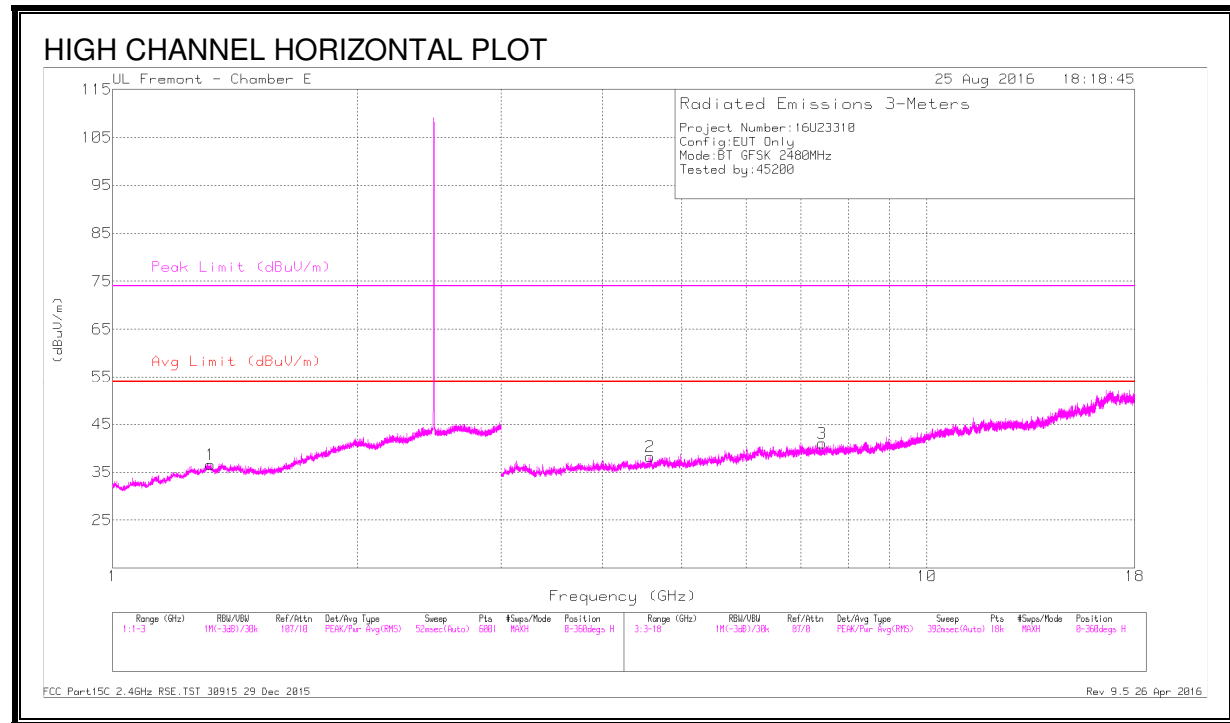

DATA

Marker	Frequenc y (GHz)	Meter Readin g (dBuV)	Det	AF T711 (dB/m)	Amp/Cbl/Filtr/ Pad (dB)	Correcte d Reading (dBuV/m)	Avg Limit (dBuV/m)	Margin (dB)	Peak Limit (dBuV/m)	PK Margin (dB)	Azimet h (Degs)	Height (cm)	Polarit y
1	* 1.321	35.31	PKFH	29.3	-22.2	42.41	-	-	74	-31.59	148	130	H
	* 1.318	23.81	VA1T	29.3	-22.3	30.81	54	-23.19	-	-	148	130	H
5	* 4.571	38.87	PKFH	33.8	-29.9	42.77	-	-	74	-31.23	236	104	H
	* 4.571	27.93	VA1T	33.8	-29.9	31.83	54	-22.17	-	-	236	104	H
6	* 7.44	39.29	PKFH	35.5	-27.5	47.29	-	-	74	-26.71	66	255	H
	* 7.44	30.15	VA1T	35.5	-27.5	38.15	54	-15.85	-	-	66	255	H
2	* 4.96	45.28	PKFH	34	-30.5	48.78	-	-	74	-25.22	318	293	V
	* 4.96	39.89	VA1T	34	-30.5	43.39	54	-10.61	-	-	318	293	V
3	* 10.836	35.45	PKFH	38	-22.7	50.75	-	-	74	-23.25	342	230	V
	* 10.835	24.17	VA1T	38	-22.7	39.47	54	-14.53	-	-	342	230	V
4	* 11.409	36.44	PKFH	38.2	-22	52.64	-	-	74	-21.36	120	298	V
	* 11.411	23.74	VA1T	38.2	-22.1	39.84	54	-14.16	-	-	120	298	V

* - indicates frequency in CFR47 Pt 15 / IC RSS-Restricted Band

PKFH - FHSS: RB=100k/1MHz VB=3 x RB, Peak

VA1T - FHSS: Linear Voltage Average VB=1/Ton where: Ton is transmit duration

8.2.2. HIGH POWER ENHANCED DATA RATE 8PSK MODULATION

RESTRICTED BANDEDGE (LOW CHANNEL, HORIZONTAL)

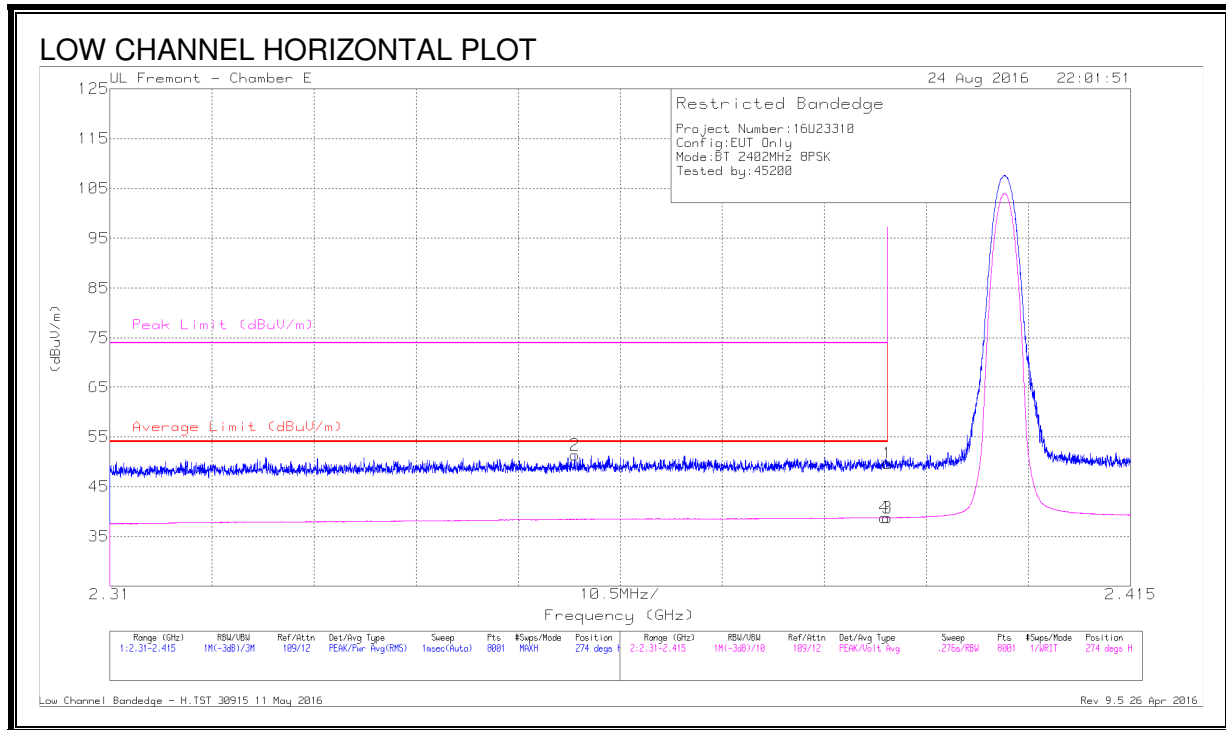

DATA

Marker	Frequency (GHz)	Meter Reading (dBuV)	Det	AF T711 (dB/m)	Amp/Cbl/F ltr/Pad (dB)	Corrected Reading (dBuV/m)	Average Limit (dBuV/m)	Margin (dB)	Peak Limit (dBuV/m)	PK Margin (dB)	Azimuth (Degs)	Height (cm)	Polarity
1	* 2.39	37.47	Pk	32.1	-19.9	49.67	-	-	74	-24.33	274	156	H
2	* 2.358	39.44	Pk	31.9	-20	51.34	-	-	74	-22.66	274	156	H
3	* 2.39	26.57	VA1T	32.1	-19.9	38.77	54	-15.23	-	-	274	156	H
4	* 2.39	26.58	VA1T	32.1	-19.9	38.78	54	-15.22	-	-	274	156	H

* - indicates frequency in CFR47 Pt 15 / IC RSS-Restricted Band

Pk - Peak detector

VA1T - FHSS: Linear Voltage Average VB=1/Ton where: Ton is transmit duration

RESTRICTED BANDEGE (LOW CHANNEL, VERTICAL)

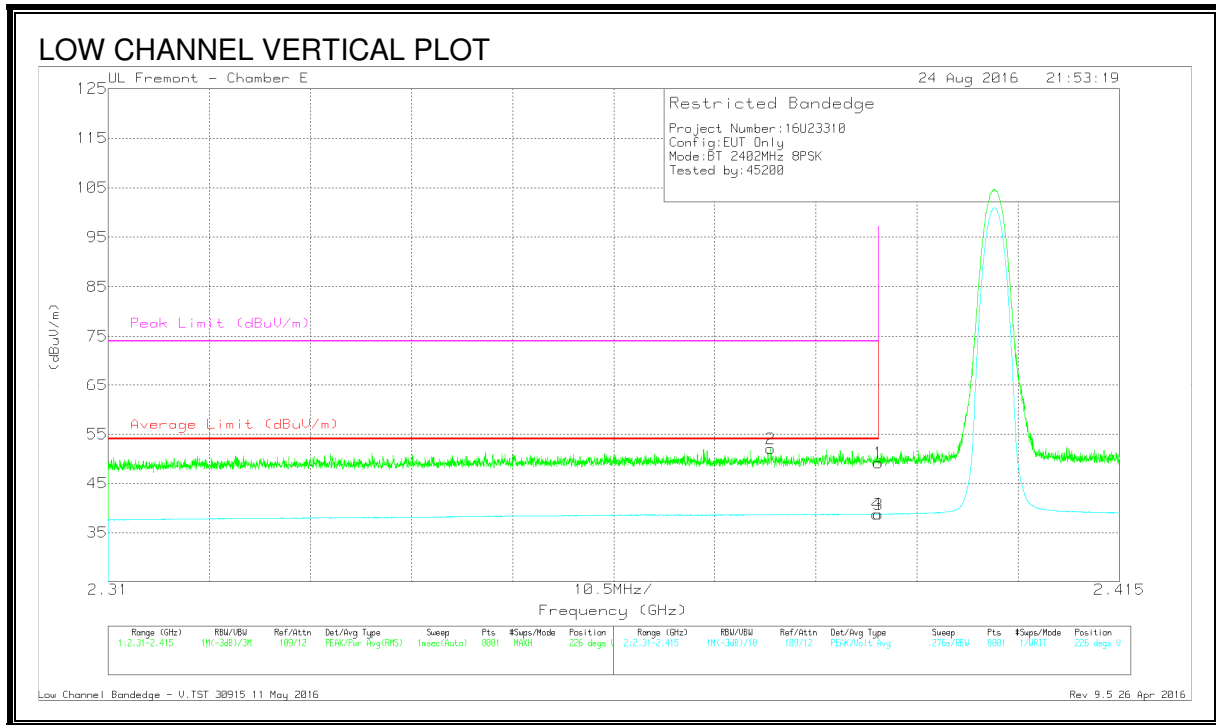

DATA

Marker	Frequency (GHz)	Meter Reading (dBuV)	Det	AF T711 (dB/m)	Amp/Cbl/F ltr/Pad (dB)	Corrected Reading (dBuV/m)	Average Limit (dBuV/m)	Margin (dB)	Peak Limit (dBuV/m)	PK Margin (dB)	Azimuth (Degs)	Height (cm)	Polarity
1	* 2.39	36.93	Pk	32.1	-19.9	49.13	-	-	74	-24.87	226	389	V
2	* 2.379	40.04	Pk	32	-20	52.04	-	-	74	-21.96	226	389	V
3	* 2.39	26.53	VA1T	32.1	-19.9	38.73	54	-15.27	-	-	226	389	V
4	* 2.39	26.57	VA1T	32.1	-19.9	38.77	54	-15.23	-	-	226	389	V

* - indicates frequency in CFR47 Pt 15 / IC RSS-Restricted Band

Pk - Peak detector

VA1T - FHSS: Linear Voltage Average VB=1/Ton where: Ton is transmit duration

RESTRICTED BANDEDGE (HIGH CHANNEL, HORIZONTAL)

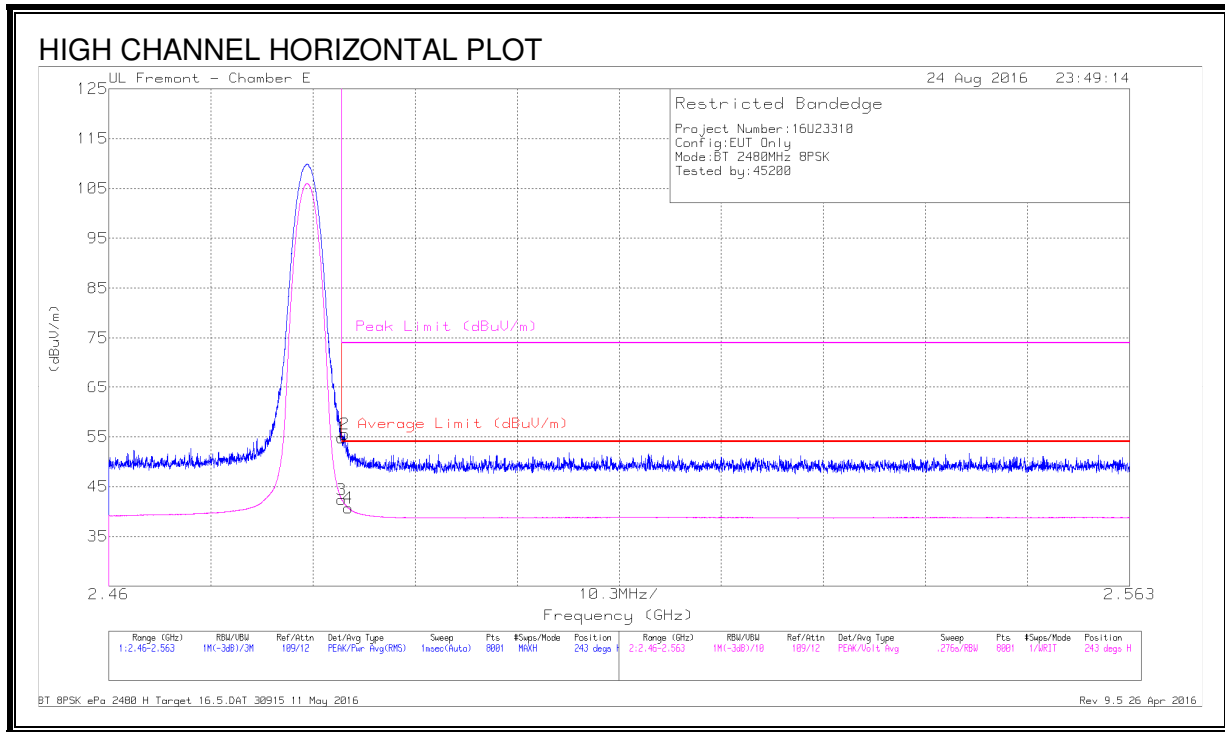

DATA

Marker	Frequency (GHz)	Meter Reading (dBuV)	Det	AF T711 (dB/m)	Amp/Cbl/Ftr/Pad (dB)	Corrected Reading (dBuV/m)	Average Limit (dBuV/m)	Margin (dB)	Peak Limit (dBuV/m)	PK Margin (dB)	Azimuth (Degs)	Height (cm)	Polarity
1	* 2.484	42.51	Pk	32.3	-20	54.81	-	-	74	-19.19	243	101	H
2	* 2.484	43.23	Pk	32.3	-20	55.53	-	-	74	-18.47	243	101	H
3	* 2.484	30.07	VA1T	32.3	-20	42.37	54	-11.63	-	-	243	100	H
4	* 2.484	28.42	VA1T	32.3	-20	40.72	54	-13.28	-	-	243	100	H

* - indicates frequency in CFR47 Pt 15 / IC RSS-Restricted Band

Pk - Peak detector

VA1T - FHSS: Linear Voltage Average VB=1/Ton where: Ton is transmit duration

RESTRICTED BANDEGE (HIGH CHANNEL, VERTICAL)

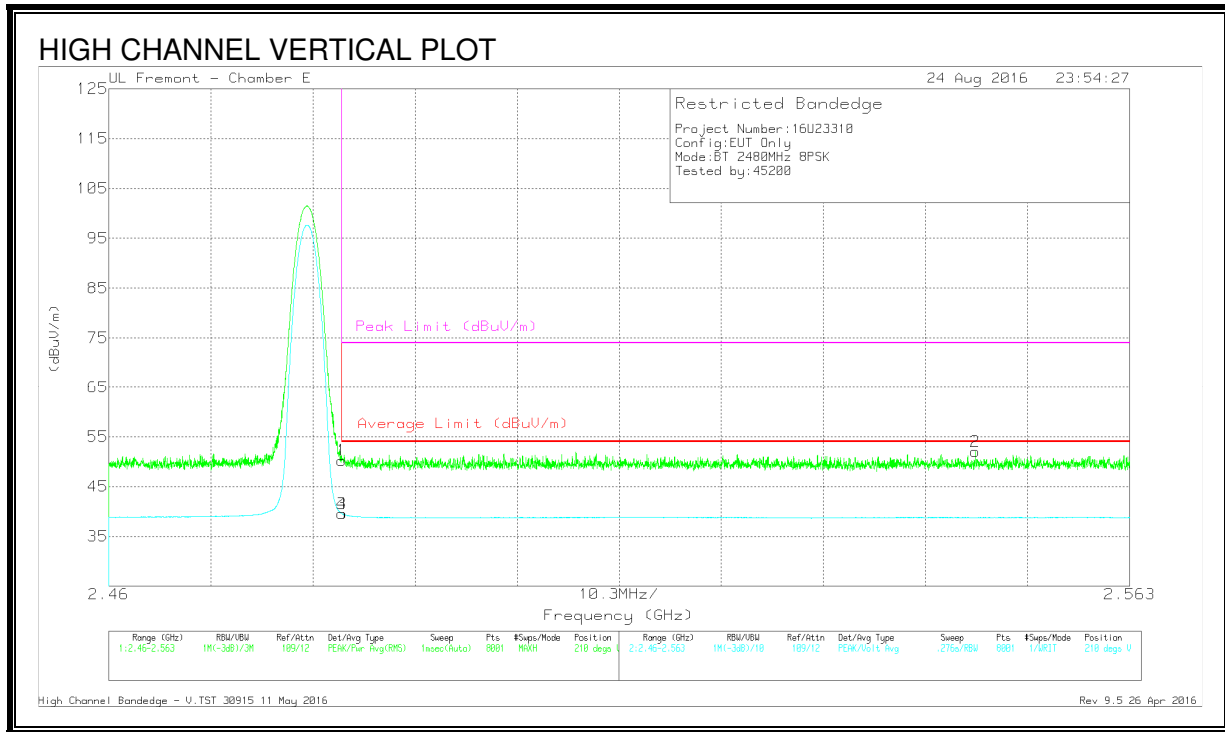

DATA

Marker	Frequency (GHz)	Meter Reading (dBuV)	Det	AF T711 (dB/m)	Amp/Cbl/F ltr/Pad (dB)	Corrected Reading (dBuV/m)	Average Limit (dBuV/m)	Margin (dB)	Peak Limit (dBuV/m)	PK Margin (dB)	Azimuth (Degs)	Height (cm)	Polarity
1	* 2.484	37.96	Pk	32.3	-20	50.26	-	-	74	-23.74	210	357	V
3	* 2.484	27.27	VA1T	32.3	-20	39.57	54	-14.43	-	-	210	356	V
4	* 2.484	27.25	VA1T	32.3	-20	39.55	54	-14.45	-	-	210	356	V
2	2.547	39.81	Pk	32.4	-20.2	52.01	-	-	74	-21.99	210	357	V

* - indicates frequency in CFR47 Pt 15 / IC RSS-Restricted Band

Pk - Peak detector

VA1T - FHSS: Linear Voltage Average VB=1/Ton where: Ton is transmit duration

HARMONICS AND SPURIOUS EMISSIONS

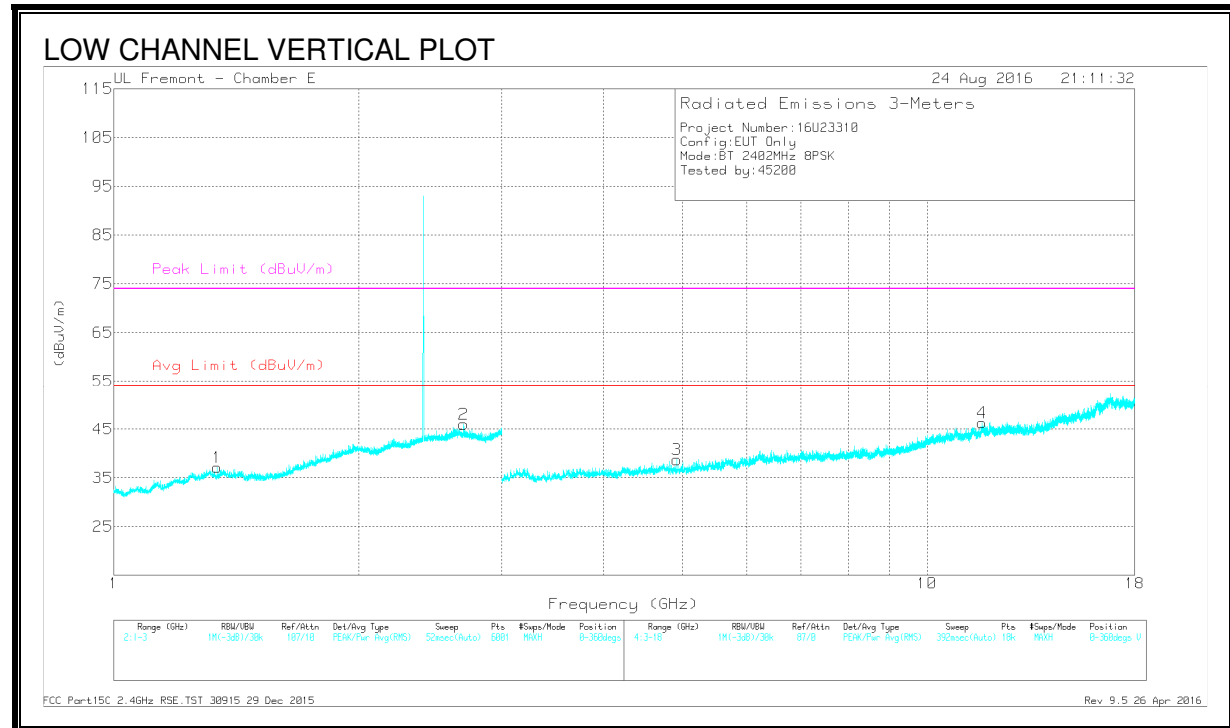
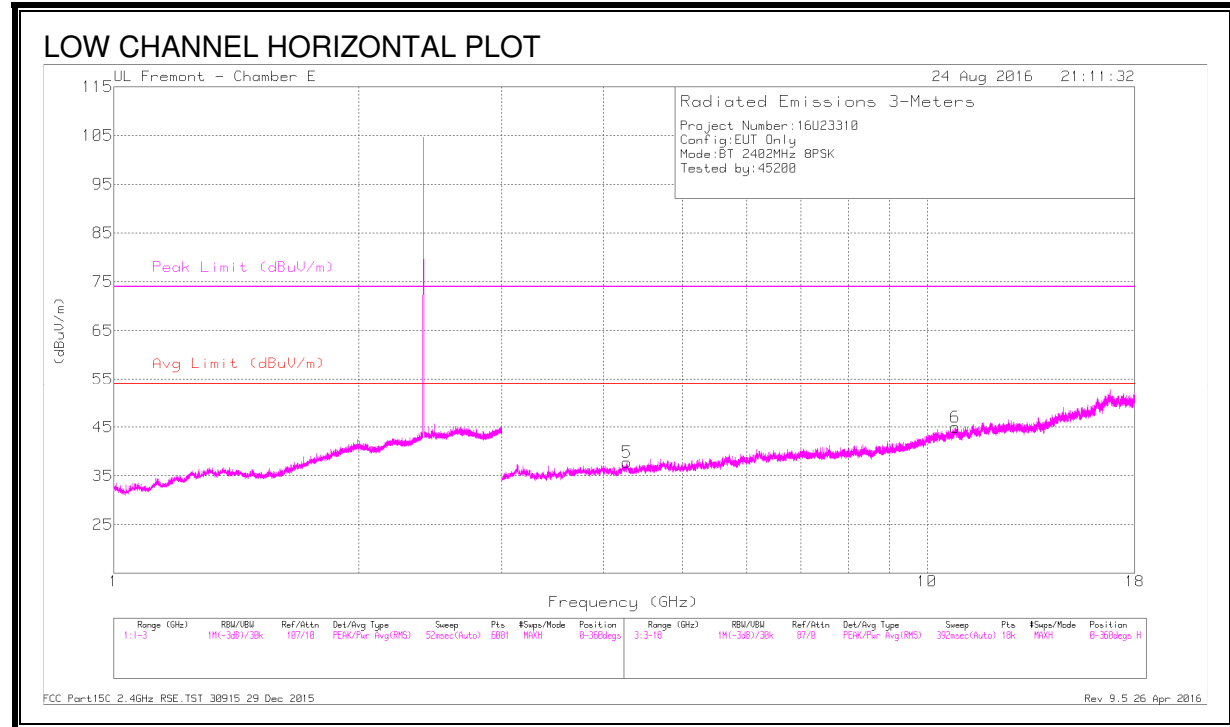

DATA

Marker	Frequency (GHz)	Meter Reading (dBuV)	Det	AF T711 (dB/m)	Amp/Cbl/Filtr/P ad (dB)	Corrected Reading (dBuV/m)	Avg Limit (dBuV/m)	Margin (dB)	Peak Limit (dBuV/m)	PK Margin (dB)	Azimuth (Degs)	Height (cm)	Polarity
1	* 1.341	34.81	PKFH	29.2	-22.4	41.61	-	-	74	-32.39	27	400	V
	* 1.341	23.39	VA1T	29.2	-22.4	30.19	54	-23.81	-	-	27	400	V
2	* 2.691	37.11	PKFH	32.6	-19.7	50.01	-	-	74	-23.99	177	248	V
	* 2.694	25.18	VA1T	32.6	-19.7	38.08	54	-15.92	-	-	177	248	V
5	* 4.278	39.36	PKFH	33.3	-29.3	43.36	-	-	74	-30.64	325	264	H
	* 4.279	27.72	VA1T	33.3	-29.3	31.72	54	-22.28	-	-	325	264	H
6	* 10.824	35.95	PKFH	37.9	-22.8	51.05	-	-	74	-22.95	87	123	H
	* 10.824	24.26	VA1T	37.9	-22.8	39.36	54	-14.64	-	-	87	123	H
3	* 4.925	40.5	PKFH	34	-30.6	43.9	-	-	74	-30.1	57	148	V
	* 4.924	28.46	VA1T	34	-30.6	31.86	54	-22.14	-	-	57	148	V
4	* 11.688	35.15	PKFH	38.6	-22.4	51.35	-	-	74	-22.65	322	339	V
	* 11.691	23.94	VA1T	38.6	-22.4	40.14	54	-13.86	-	-	322	339	V

* - indicates frequency in CFR47 Pt 15 / IC RSS-Restricted Band

PKFH - FHSS: RB=100k/1MHz VB=3 x RB, Peak

VA1T - FHSS: Linear Voltage Average VB=1/Ton where: Ton is transmit duration

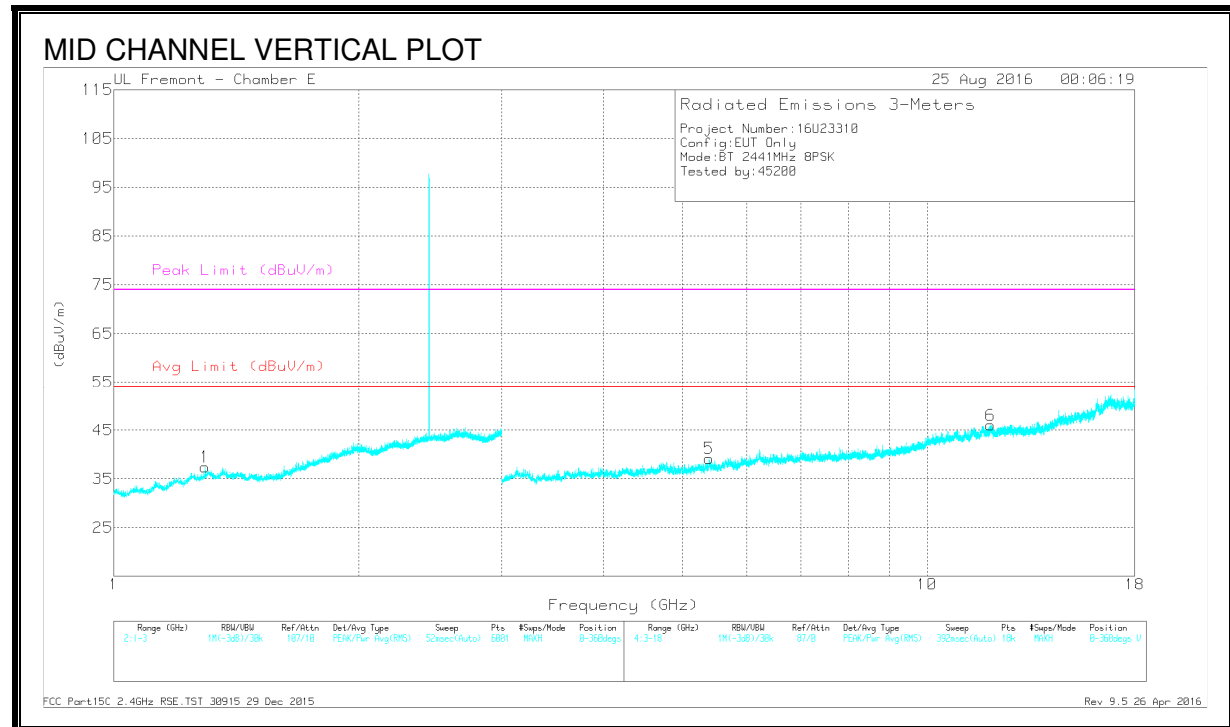
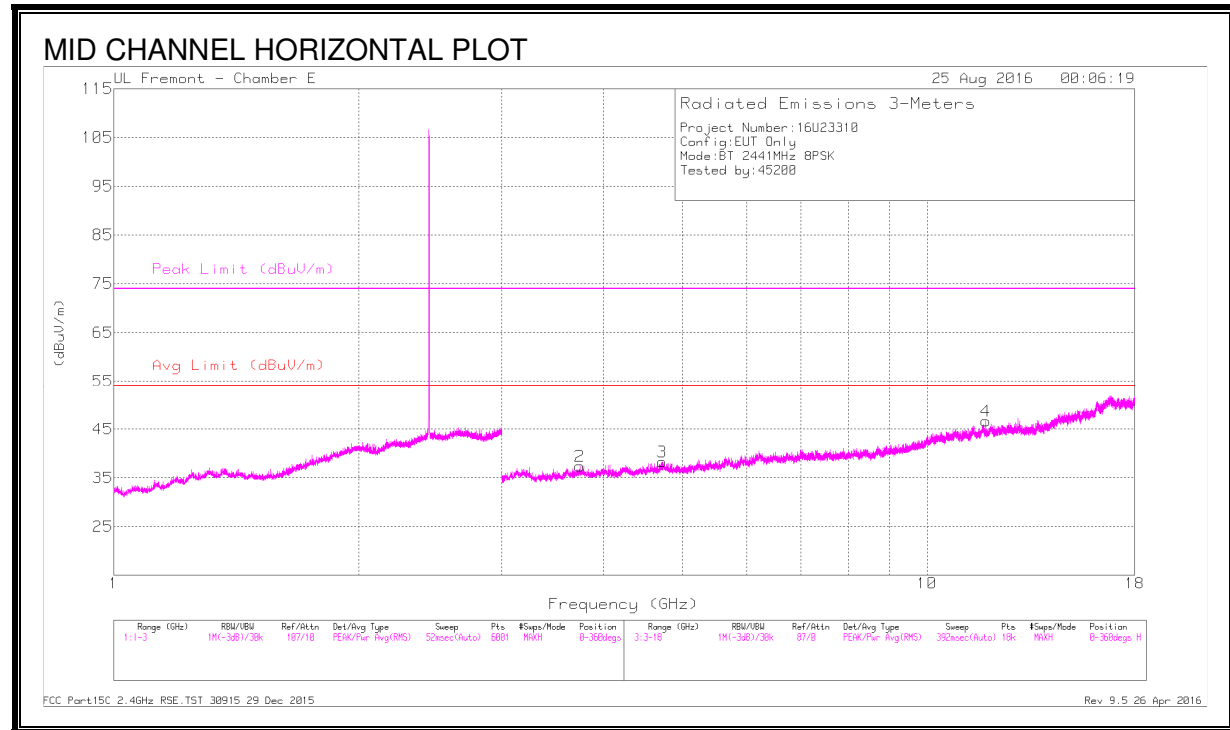

DATA

Marker	Frequency (GHz)	Meter Reading (dBuV)	Det	AF T711 (dB/m)	Amp/Cbl/Filtr/Pad (dB)	Corrected Reading (dBuV/m)	Avg Limit (dBuV/m)	Margin (dB)	Peak Limit (dBuV/m)	PK Margin (dB)	Azimuth (Degs)	Height (cm)	Polarity
1	* 1.296	34.83	PKFH	29.3	-22.5	41.63	-	-	74	-32.37	267	323	V
	* 1.298	23.73	VA1T	29.3	-22.6	30.43	54	-23.57	-	-	267	323	V
2	* 3.743	39.42	PKFH	33.1	-30	42.52	-	-	74	-31.48	312	249	H
	* 3.74	27.9	VA1T	33.1	-30	31	54	-23	-	-	312	249	H
3	* 4.729	38.9	PKFH	34	-29	43.9	-	-	74	-30.1	16	136	H
	* 4.729	27.99	VA1T	34	-29	32.99	54	-21.01	-	-	16	136	H
4	* 11.813	36.4	PKFH	38.7	-23.8	51.3	-	-	74	-22.7	307	227	H
	* 11.815	24.79	VA1T	38.7	-23.8	39.69	54	-14.31	-	-	307	227	H
5	* 5.398	38.3	PKFH	34.4	-29.1	43.6	-	-	74	-30.4	32	241	V
	* 5.399	27.89	VA1T	34.4	-29.1	33.19	54	-20.81	-	-	32	241	V
6	* 11.972	35.59	PKFH	38.9	-22.6	51.89	-	-	74	-22.11	127	277	V
	* 11.973	24.14	VA1T	38.9	-22.6	40.44	54	-13.56	-	-	127	277	V

* - indicates frequency in CFR47 Pt 15 / IC RSS-Restricted Band

PKFH - FHSS: RB=100k/1MHz VB=3 x RB, Peak

VA1T - FHSS: Linear Voltage Average VB=1/Ton where: Ton is transmit duration

HARMONICS AND SPURIOUS EMISSIONS

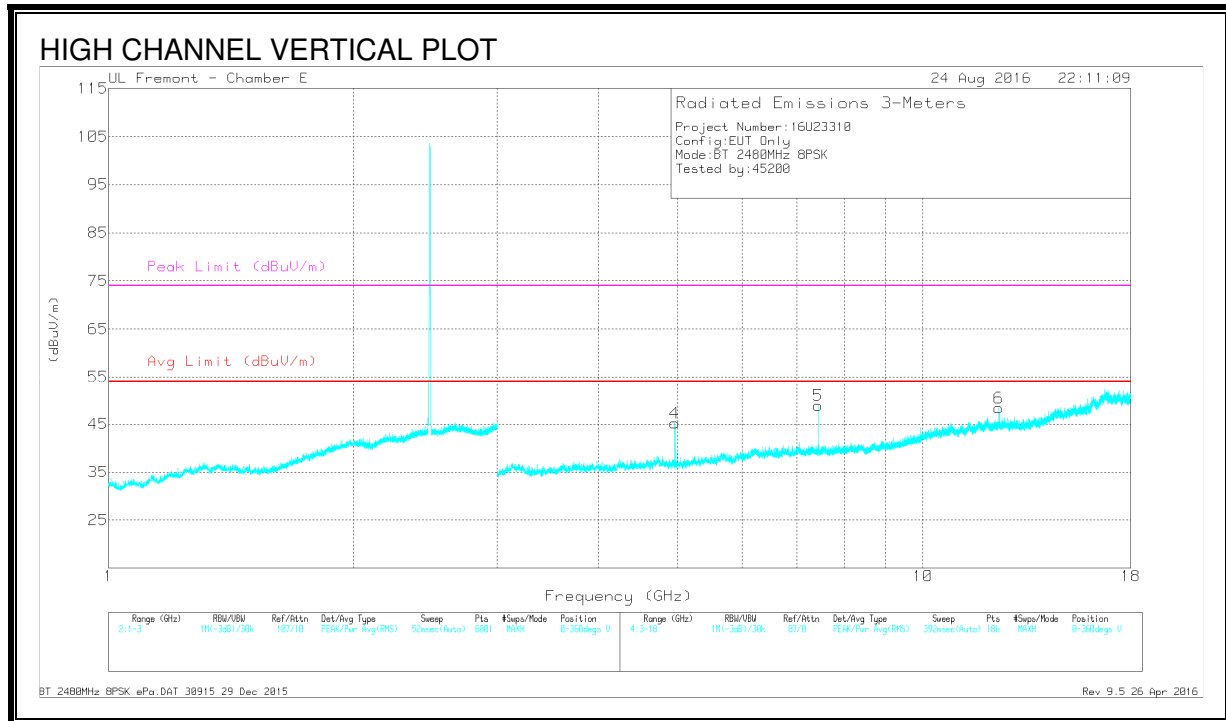
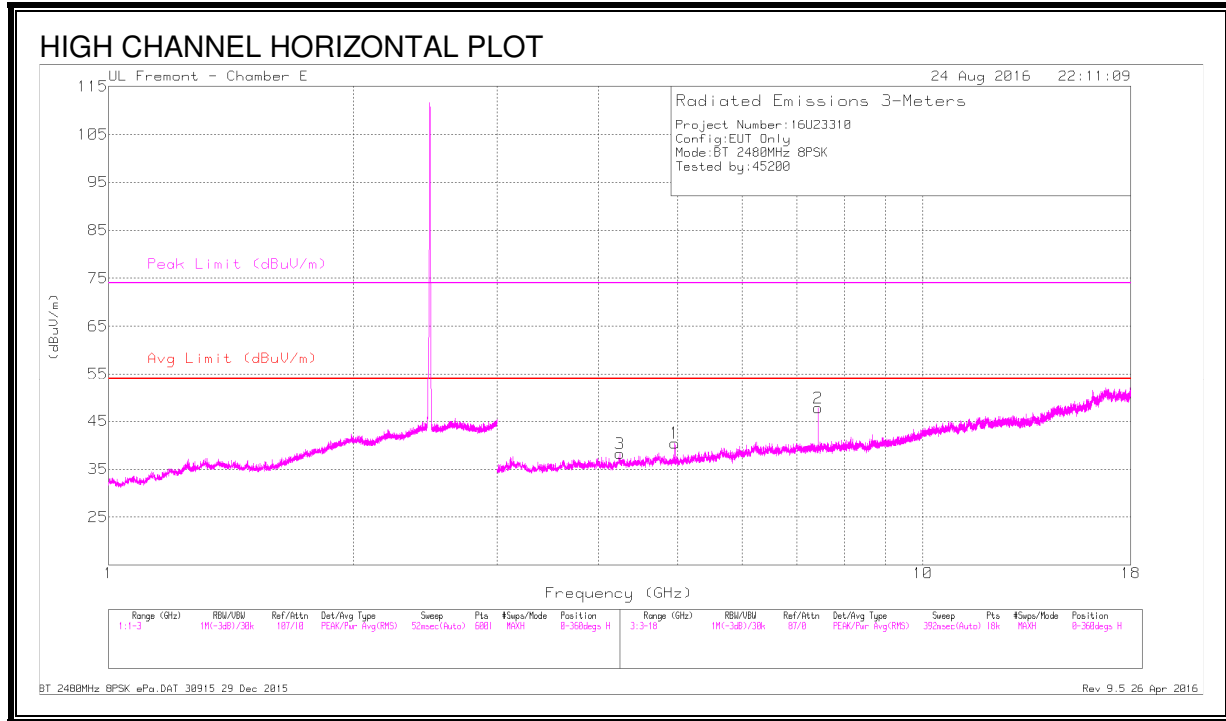

DATA

Marker	Frequency (GHz)	Meter Reading (dBuV)	Det	AF T711 (dB/m)	Amp/Cbl/Filtr/Pad (dB)	Corrected Reading (dBuV/m)	Avg Limit (dBuV/m)	Margin (dB)	Peak Limit (dBuV/m)	PK Margin (dB)	Azimuth (Degs)	Height (cm)	Polarity
1	* 4.96	44.28	PKFH	34	-30.5	47.78	-	-	74	-26.22	226	381	H
	* 4.96	36.76	VA1T	34	-30.5	40.26	54	-13.74	-	-	226	381	H
2	* 7.439	46.16	PKFH	35.5	-27.5	54.16	-	-	74	-19.84	64	312	H
	* 7.44	40.22	VA1T	35.5	-27.5	48.22	54	-5.78	-	-	64	312	H
3	* 4.246	38.81	PKFH	33.3	-29	43.11	-	-	74	-30.89	114	292	H
	* 4.248	27.34	VA1T	33.3	-29	31.64	54	-22.36	-	-	114	292	H
4	* 7.44	45.12	PKFH	35.5	-27.5	53.12	-	-	74	-20.88	44	256	V
	* 7.44	38.42	VA1T	35.5	-27.5	46.42	54	-7.58	-	-	44	256	V
5	* 12.4	39.56	PKFH	39	-23.5	55.06	-	-	74	-18.94	175	236	V
	* 12.4	29.71	VA1T	39	-23.5	45.21	54	-8.79	-	-	175	236	V
6	* 4.96	43.51	PKFH	34	-30.5	47.01	-	-	74	-26.99	135	348	V
	* 4.96	34.42	VA1T	34	-30.5	37.92	54	-16.08	-	-	135	348	V

* - indicates frequency in CFR47 Pt 15 / IC RSS-Restricted Band

PKFH - FHSS: RB=100k/1MHz VB=3 x RB, Peak

VA1T - FHSS: Linear Voltage Average VB=1/Ton where: Ton is transmit duration

8.3. WORST-CASE BELOW 1 GHz

SPURIOUS EMISSIONS 30 TO 1000 MHz (WORST-CASE CONFIGURATION, HORIZONTAL)

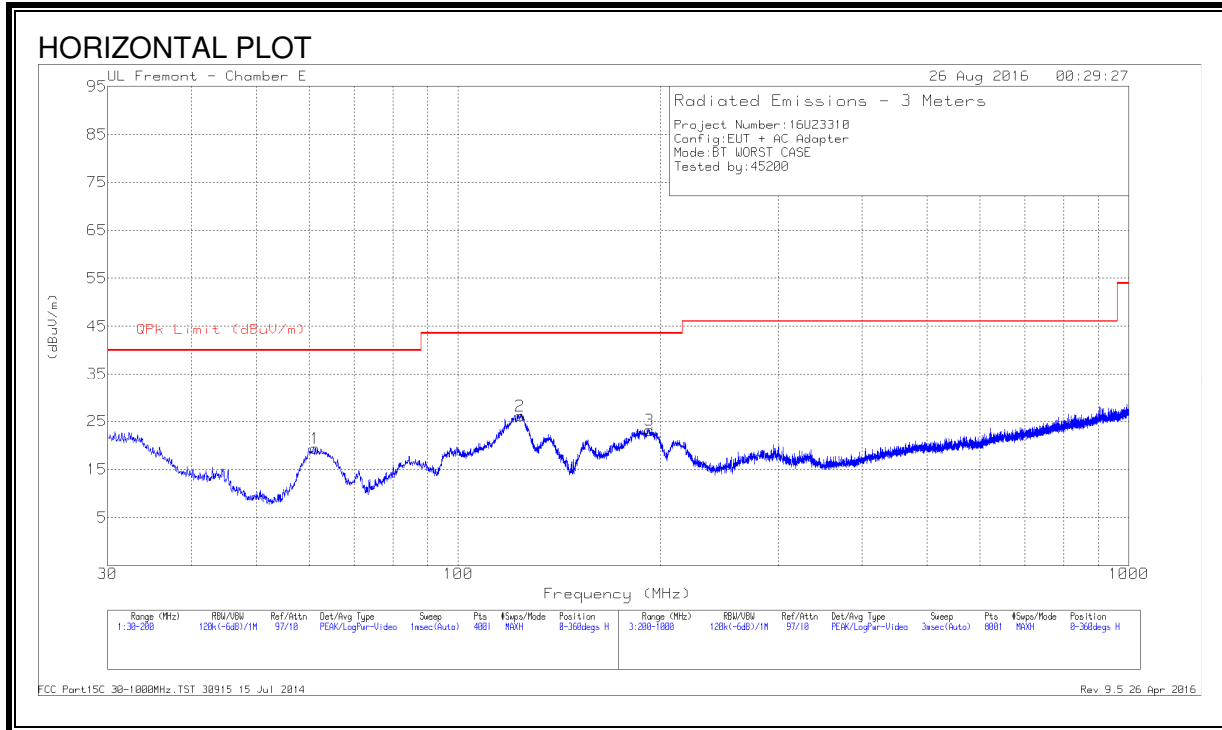

SPURIOUS EMISSIONS 30 TO 1000 MHz (WORST-CASE CONFIGURATION, VERTICAL)

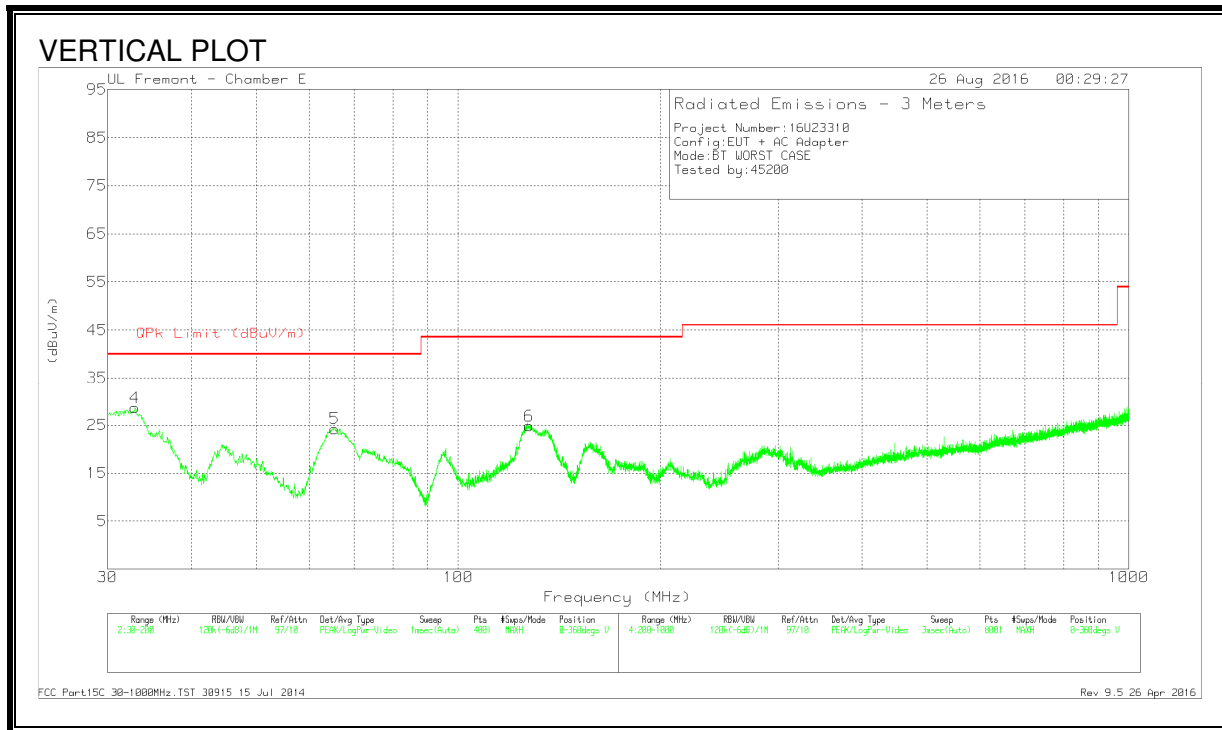

DATA

Marker	Frequency (MHz)	Meter Reading (dBuV)	Det	AF T243 (dB/m)	Amp/Cbl (dB)	Corrected Reading (dBuV/m)	QPk Limit (dBuV/m)	Margin (dB)	Azimuth (Degs)	Height (cm)	Polarity
2	* 123.7125	39.32	Pk	18.1	-31.3	26.12	43.52	-17.4	0-360	200	H
6	* 127.665	37.91	Pk	18	-31.1	24.81	43.52	-18.71	0-360	100	V
4	32.975	37.51	Pk	22.9	-31.8	28.61	40	-11.39	0-360	100	V
1	61.2375	39.57	Pk	11.5	-31.7	19.37	40	-20.63	0-360	300	H
5	65.4875	44.07	Pk	11.8	-31.6	24.27	40	-15.73	0-360	100	V
3	192.605	38.33	Pk	15.6	-30.8	23.13	43.52	-20.39	0-360	100	H

* - indicates frequency in CFR47 Pt 15 / IC RSS-Restricted Band
 Pk - Peak detector

8.4. WORST-CASE ABOVE 18 GHz

SPURIOUS EMISSIONS 18 TO 26 GHz

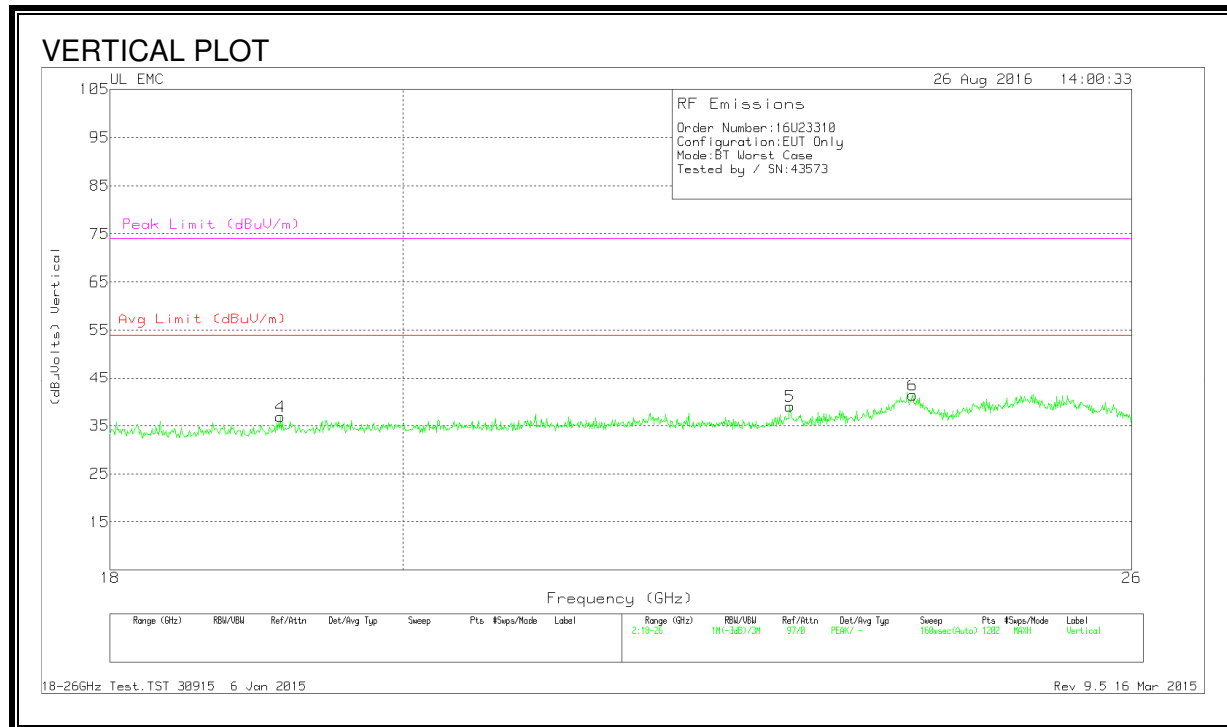
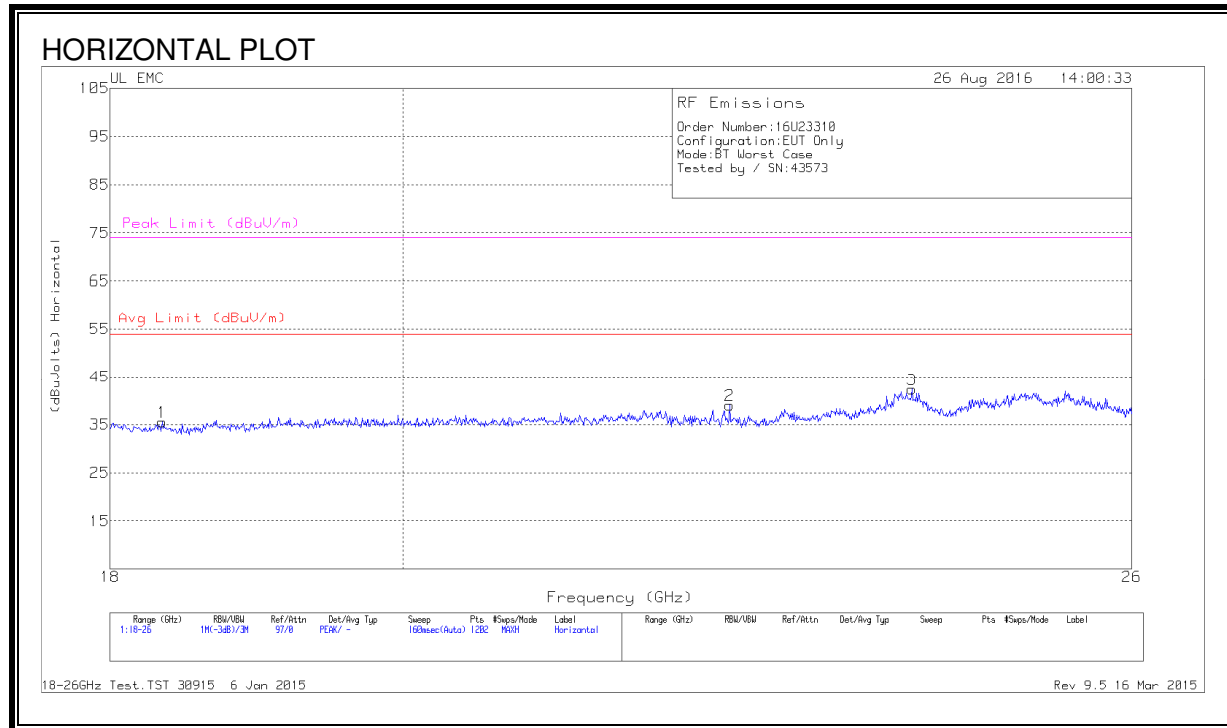

Data

Marker	Frequency (GHz)	Meter Reading (dBuV)	Det	AF T449 (dB/m)	Amp/Cbl (dB)	Dist Corr (dB)	Corrected Reading (dBuVolts)	Avg Limit (dBuV/m)	Margin (dB)	Peak Limit (dBuV/m)	PK Margin (dB)
1	18.34	37.8	Pk	32.4	-25.2	-9.5	35.5	54	-18.5	74	-38.5
2	22.496	39.8	Pk	33.5	-24.8	-9.5	39	54	-15	74	-35
3	24.022	42.03	Pk	34	-24.2	-9.5	42.33	54	-11.67	74	-31.67
4	19.139	38.33	Pk	32.7	-24.7	-9.5	36.83	54	-17.17	74	-37.167
5	22.989	40	Pk	33.4	-24.9	-9.5	39	54	-15	74	-35
6	24.028	40.93	Pk	34	-24.1	-9.5	41.33	54	-12.67	74	-32.67

Pk - Peak detector

9. AC POWER LINE CONDUCTED EMISSIONS

LIMITS

FCC §15.207 (a)

RSS-Gen 8.8

Frequency of Emission (MHz)	Conducted Limit (dB μ V)	
	Quasi-peak	Average
0.15-0.5	66 to 56 *	56 to 46 *
0.5-5	56	46
5-30	60	50

*Decreases with the logarithm of the frequency.

TEST PROCEDURE

The EUT is placed on a non-conducting table 40 cm from the vertical ground plane and 80 cm above the horizontal ground plane. The EUT is configured in accordance with ANSI C63.10.

The receiver is set to a resolution bandwidth of 9 kHz. Peak detection is used unless otherwise noted as quasi-peak or average.

Line conducted data is recorded for both NEUTRAL and HOT lines.

RESULTS

9.1. EUT POWERED BY AC/DC ADAPTER VIA USB CABLE

LINE 1 RESULTS

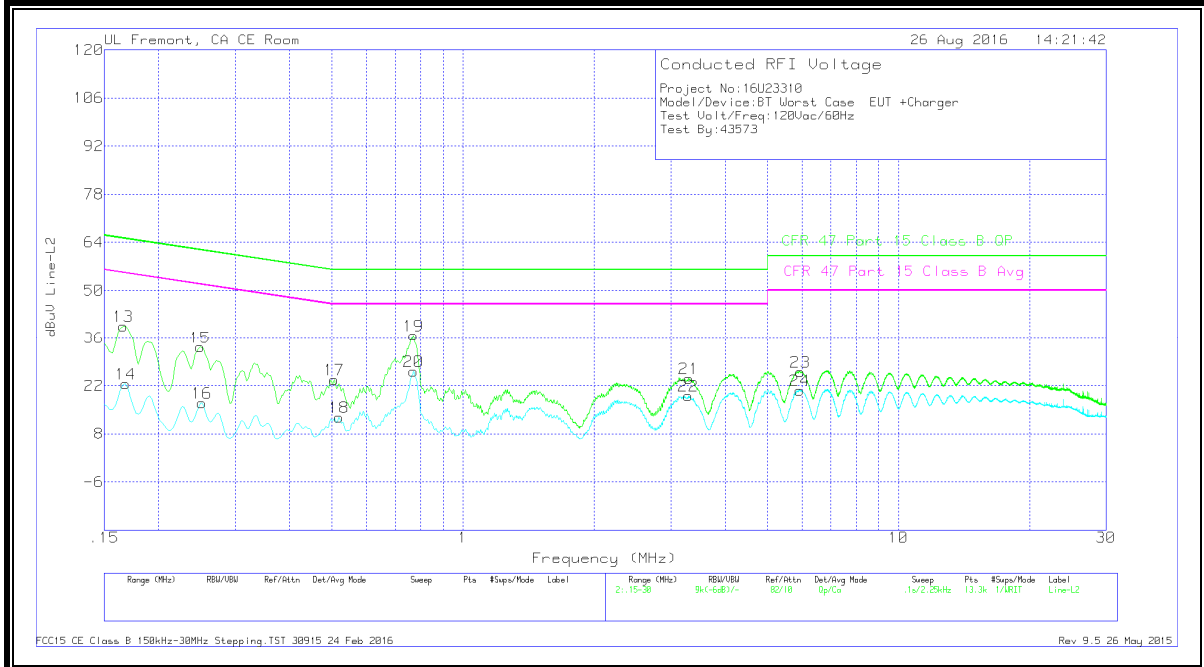
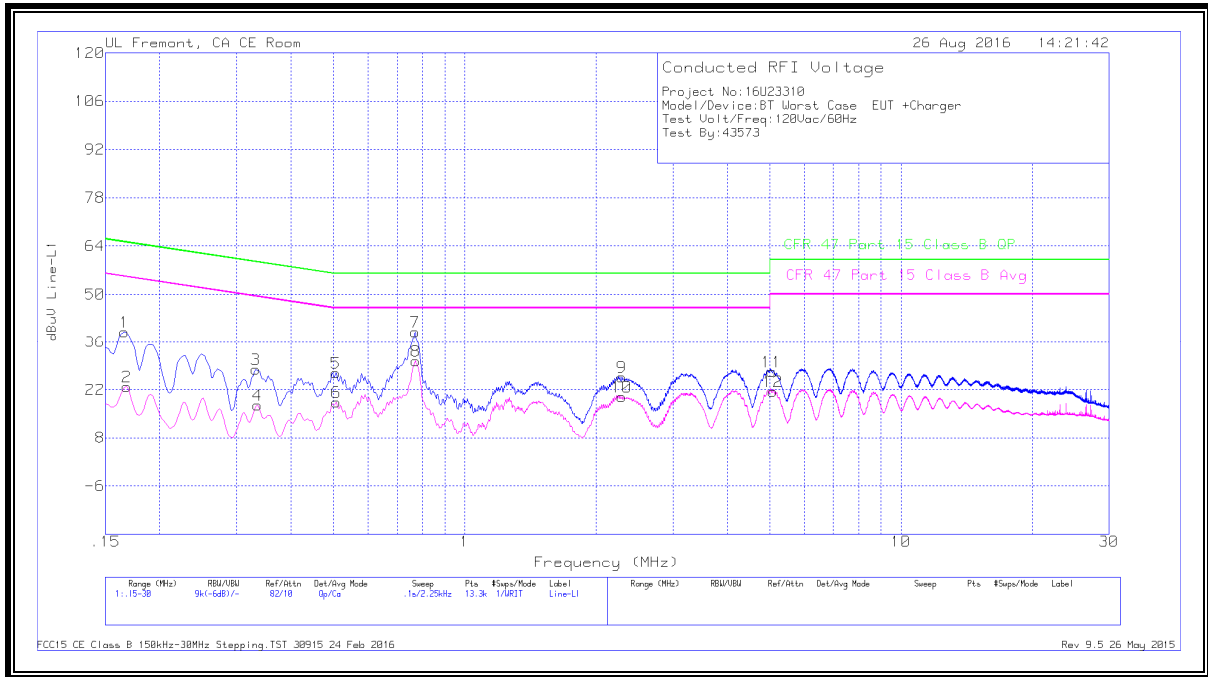

WORST EMISSIONS

Range 1: Line-L1 .15 - 30MHz

Marker	Frequency (MHz)	Meter Reading (dBuV)	Det	LISN L1	LC Cables 1&3	Limiter (dB)	Corrected Reading dBuV	CFR 47 Part 15 Class B QP	QP Margin (dB)	CFR 47 Part 15 Class B Avg	Av(CISPR) Margin (dB)
1	.16575	28.87	Qp	0	0	10.1	38.97	65.17	-26.2	-	-
2	.168	12.85	Ca	0	0	10.1	22.95	-	-	55.06	-32.11
3	.33225	17.82	Qp	0	0	10.1	27.92	59.39	-31.47	-	-
4	.3345	7.34	Ca	0	0	10.1	17.44	-	-	49.34	-31.9
5	.5055	16.76	Qp	0	0	10.1	26.86	56	-29.14	-	-
6	.50775	8.19	Ca	0	0	10.1	18.29	-	-	46	-27.71
7	.76875	28.94	Qp	0	0	10.1	39.04	56	-16.96	-	-
8	.771	20.32	Ca	0	0	10.1	30.42	-	-	46	-15.58
9	2.292	15.41	Qp	0	.1	10.1	25.61	56	-30.39	-	-
10	2.292	9.78	Ca	0	.1	10.1	19.98	-	-	46	-26.02
11	5.05613	17.04	Qp	0	.1	10.1	27.24	60	-32.76	-	-
12	5.07975	11.26	Ca	0	.1	10.1	21.46	-	-	50	-28.54

Qp - Quasi-Peak detector

Ca - CISPR average detection

Range 2: Line-L2 .15 - 30MHz

Marker	Frequency (MHz)	Meter Reading (dBuV)	Det	LISN L2	LC Cables 2&3	Limiter (dB)	Corrected Reading dBuV	CFR 47 Part 15 Class B QP	QP Margin (dB)	CFR 47 Part 15 Class B Avg	Av(CISPR) Margin (dB)
13	.16575	29.47	Qp	0	0	10.1	39.57	65.17	-25.6	-	-
14	.168	12.5	Ca	0	0	10.1	22.6	-	-	55.06	-32.46
15	.249	23.24	Qp	0	0	10.1	33.34	61.79	-28.45	-	-
16	.25125	6.83	Ca	0	0	10.1	16.93	-	-	51.72	-34.79
17	.5055	13.59	Qp	0	0	10.1	23.69	56	-32.31	-	-
18	.519	2.76	Ca	0	0	10.1	12.86	-	-	46	-33.14
19	.76875	26.63	Qp	0	0	10.1	36.73	56	-19.27	-	-
20	.76875	16.01	Ca	0	0	10.1	26.11	-	-	46	-19.89
21	3.30225	13.91	Qp	0	.1	10.1	24.11	56	-31.89	-	-
22	3.29325	8.91	Ca	0	.1	10.1	19.11	-	-	46	-26.89
23	5.9505	15.76	Qp	0	.1	10.2	26.06	60	-33.94	-	-
24	5.9415	10.38	Ca	0	.1	10.2	20.68	-	-	50	-29.32

Qp - Quasi-Peak detector

Ca - CISPR average detection

9.2. EUT POWERED BY HOST PC VIA USB CABLE

LINE 1 RESULTS

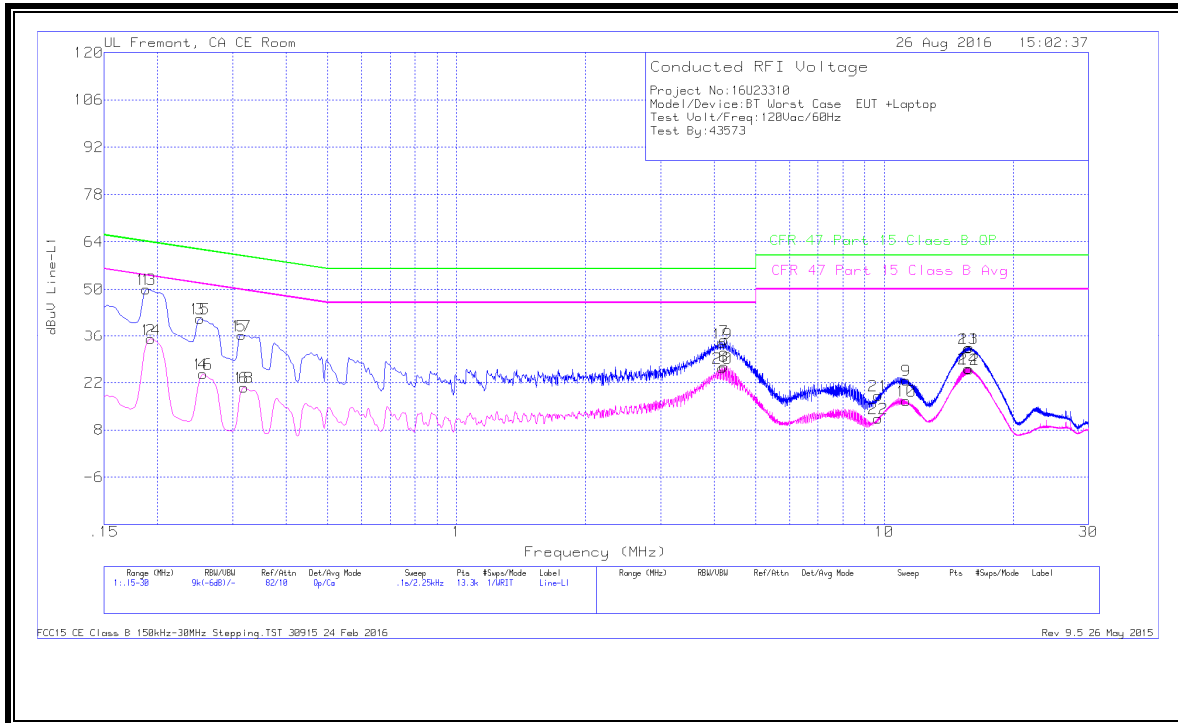

LINE 2 RESULTS

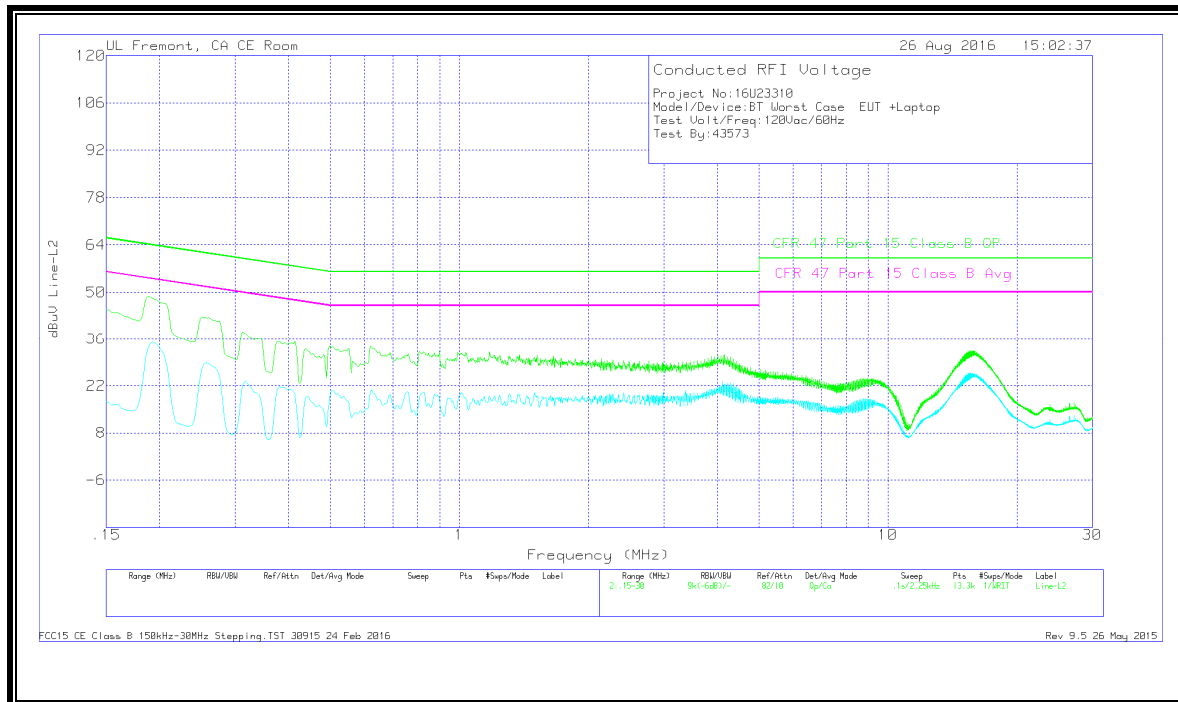

WORST EMISSIONS

Range 1: Line-L1 .15 - 30MHz

Marker	Frequency (MHz)	Meter Reading (dBuV)	Det	LISN L1	LC Cables 1&3	Limiter (dB)	Corrected Reading dBuV	CFR 47 Part 15 Class B QP	QP Margin (dB)	CFR 47 Part 15 Class B Avg	Av(CISPR) Margin (dB)
1	.18825	39.96	Qp	0	0	10.1	50.06	64.11	-14.05	-	-
2	.19275	24.91	Ca	0	0	10.1	35.01	-	-	53.92	-18.91
3	.25125	31.28	Qp	0	0	10.1	41.38	61.72	-20.34	-	-
4	.25575	14.46	Ca	0	0	10.1	24.56	-	-	51.57	-27.01
5	.31425	26.16	Qp	0	0	10.1	36.26	59.86	-23.6	-	-
6	.31875	10.46	Ca	0	0	10.1	20.56	-	-	49.74	-29.18
7	4.28775	24.03	Qp	0	.1	10.1	34.23	56	-21.77	-	-
8	4.28775	16.63	Ca	0	.1	10.1	26.83	-	-	46	-19.17
9	10.63388	11.85	Qp	0	.2	10.2	22.25	60	-37.75	-	-
10	10.64175	5.53	Ca	0	.2	10.2	15.93	-	-	50	-34.07
11	15.819	22.02	Qp	0	.2	10.2	32.42	60	-27.58	-	-
12	15.82575	15.66	Ca	0	.2	10.2	26.06	-	-	50	-23.94

Qp - Quasi-Peak detector

Ca - CISPR average detection

Range 2: Line-L2 .15 - 30MHz

Marker	Frequency (MHz)	Meter Reading (dBuV)	Det	LISN L2	LC Cables 2&3	Limiter (dB)	Corrected Reading dBuV	CFR 47 Part 15 Class B QP	QP Margin (dB)	CFR 47 Part 15 Class B Avg	Av(CISPR) Margin (dB)
13	.18825	38.72	Qp	0	0	10.1	48.82	64.11	-15.29	-	-
14	.19275	24.88	Ca	0	0	10.1	34.98	-	-	53.92	-18.94
15	.25125	32.53	Qp	0	0	10.1	42.63	61.72	-19.09	-	-
16	.25575	18.71	Ca	0	0	10.1	28.81	-	-	51.57	-22.76
17	.37725	25.18	Qp	0	0	10.1	35.28	58.34	-23.06	-	-
18	.38062	11.59	Ca	0	0	10.1	21.69	-	-	48.27	-26.58
19	3.90975	19.56	Qp	0	.1	10.1	29.76	56	-26.24	-	-
20	3.9075	10.58	Ca	0	.1	10.1	20.78	-	-	46	-25.22
21	11.35725	.24	Qp	0	.2	10.2	10.64	60	-49.36	-	-
22	11.35275	-3	Ca	0	.2	10.2	7.4	-	-	50	-42.6
23	15.62775	21.54	Qp	0	.2	10.2	31.94	60	-28.06	-	-
24	15.62775	15.32	Ca	0	.2	10.2	25.72	-	-	50	-24.28

Qp - Quasi-Peak detector

Ca - CISPR average detection