



# TEST REPORT

**Test Report No. :** UL-RPT-RP11241886JD07S V4.0

**Manufacturer** : Apple Inc.  
**Model No.** : A1779  
**FCC ID** : BCG-E3086A  
**Technology** : LTE – Band 7  
**Test Standard(s)** : FCC Part 27 Subpart C

1. This test report shall not be reproduced in full or partial, without the written approval of UL VS LTD.
2. The results in this report apply only to the sample(s) tested.
3. The sample tested is in compliance with the above standard(s).
4. The test results in this report are traceable to the national or international standards.
5. Version 4.0 supersedes all previous versions.

**Date of Issue:** 03 August 2016

**Checked by:**

Sarah Williams  
Engineer, Radio Laboratory

**Company Signatory:**

Steven White  
Service Lead, Radio Laboratory  
UL VS LTD



This laboratory is accredited by UKAS.  
The tests reported herein have been  
performed in accordance with its terms  
of accreditation.

---

## UL VS LTD

Pavilion A, Ashwood Park, Ashwood Way, Basingstoke, Hampshire, RG23 8BG, UK  
Telephone: +44 (0)1256 312000  
Facsimile: +44 (0)1256 312001

This page has been left intentionally blank.

## **Table of Contents**

<b>1. Customer Information.....</b>	<b>4</b>
<b>2. Summary of Testing.....</b>	<b>5</b>
2.1. General Information	5
2.2. Summary of Test Results	5
2.3. Methods and Procedures	5
2.4. Deviations from the Test Specification	5
<b>3. Equipment Under Test (EUT) .....</b>	<b>6</b>
3.1. Identification of Equipment Under Test (EUT)	6
3.2. Description of EUT	7
3.3. Modifications Incorporated in the EUT	7
3.4. Additional Information Related to Testing	8
3.5. Support Equipment	9
<b>4. Operation and Monitoring of the EUT during Testing .....</b>	<b>10</b>
4.1. Operating Modes	10
4.2. Configuration and Peripherals	10
4.3. Resource Block Allocation	11
<b>5. Measurements, Examinations and Derived Results.....</b>	<b>12</b>
5.1. General Comments	12
5.2. Test Results	13
5.2.1. Transmitter Output Power (EIRP) - LAT	13
5.2.2. Transmitter Output Power (EIRP) - UAT	23
5.2.3. Transmitter Peak-To-Average Ratio (PAR)	33
5.2.4. Transmitter Occupied Bandwidth	43
5.2.5. Transmitter Radiated Spurious Emissions - LAT	53
5.2.6. Transmitter Radiated Spurious Emissions - UAT	57
5.2.7. Transmitter Radiated Emissions at Band Edges - LAT	60
5.2.8. Transmitter Radiated Emissions at Band Edges - UAT	79
5.2.9. Transmitter Radiated Emissions at Band Edges $\pm$ X MHz – LAT	99
5.2.10. Transmitter Radiated Emissions at Band Edges $\pm$ X MHz – UAT	125
5.2.11. Transmitter Frequency Stability (Temperature Variation)	151
5.2.12. Transmitter Frequency Stability (Voltage Variation)	153
<b>6. Measurement Uncertainty .....</b>	<b>155</b>
<b>7. Report Revision History .....</b>	<b>156</b>

**1. Customer Information**

<b>Company Name:</b>	Apple Inc.
<b>Address:</b>	1 Infinite Loop Cupertino, CA 95014 U.S.A.

## **2. Summary of Testing**

### **2.1. General Information**

<b>Specification Reference:</b>	47CFR27
<b>Specification Title:</b>	Code of Federal Regulations Volume 47 (Telecommunications): Part 27 Subpart C (Miscellaneous Wireless Communication Services)
<b>Site Registration:</b>	209735
<b>Location of Testing:</b>	UL VS LTD, Unit 3 Horizon, Wade Road, Kingsland Business Park, Basingstoke, Hampshire, RG24 8AH, United Kingdom
<b>Test Dates:</b>	12 May 2016 to 08 July 2016

### **2.2. Summary of Test Results**

<b>FCC Reference (47CFR)</b>	<b>Measurement</b>	<b>Result</b>
2.1046 / 27.50(h)(2)	Transmitter Output Power (EIRP)	Complied
27.50(d)(5)	Transmitter Peak-to-Average Ratio (PAR)	Complied
2.1049	Transmitter Occupied Bandwidth	Complied
2.1053 / 27.53(m)(4)	Transmitter Radiated Spurious Emissions	Complied
2.1053 / 27.53(m)(4)	Transmitter Radiated Emissions at Band Edges	Complied
2.1053 / 27.53(m)(4)	Transmitter Radiated Emissions at Band Edges +/- X MHz	Complied
2.1055 / 27.54	Transmitter Frequency Stability (Temperature and Voltage Variation)	Complied

### **2.3. Methods and Procedures**

<b>Reference:</b>	ANSI/TIA-603-D-2010
<b>Title:</b>	Land Mobile Communications Equipment, Measurements and performance Standards
<b>Reference:</b>	FCC KDB 971168 D01 v02r02, 17 October 2014
<b>Title:</b>	Measurement Guidance for Certification of Licensed Digital Transmitters

### **2.4. Deviations from the Test Specification**

For the measurements contained within this test report, there were no deviations from, additions to, or exclusions from the test specification identified above.

### **3. Equipment Under Test (EUT)**

#### **3.1. Identification of Equipment Under Test (EUT)**

<b>Brand Name:</b>	Apple
<b>Model Name or Number:</b>	A1779
<b>Test Sample Serial Number:</b>	C7CRG011H6DH
<b>Test Sample IMEI:</b>	358640070087480 ( <i>Radiated LAT Sample</i> )
<b>Hardware Version:</b>	REV1.0
<b>Software Version:</b>	iOS: 14A241z BB FW: 0.16.04
<b>FCC ID:</b>	BCG-E3086A

<b>Brand Name:</b>	Apple
<b>Model Name or Number:</b>	A1779
<b>Test Sample Serial Number:</b>	C7CRF01JH7X9
<b>Test Sample IMEI:</b>	358640070022890 ( <i>Radiated UAT Sample</i> )
<b>Hardware Version:</b>	REV1.0
<b>Software Version:</b>	iOS: 14A241z BB FW: 0.16.04
<b>FCC ID:</b>	BCG-E3086A

<b>Brand Name:</b>	Apple
<b>Model Name or Number:</b>	A1779
<b>Test Sample Serial Number:</b>	C7CRR02THCPX
<b>Test Sample IMEI:</b>	358640070064218 ( <i>Conducted Sample #1</i> )
<b>Hardware Version Number:</b>	REV1.0
<b>Software Version Number:</b>	iOS: 14A241z BB FW: 0.16.04
<b>FCC ID:</b>	BCG-E3086A

<b>Brand Name:</b>	Apple
<b>Model Name or Number:</b>	A1779
<b>Test Sample Serial Number:</b>	C7CRR024HCPX
<b>Test Sample IMEI:</b>	358640070066221 ( <i>Conducted Sample #2</i> )
<b>Hardware Version Number:</b>	REV1.0
<b>Software Version Number:</b>	iOS: 14A241z BB FW: 0.16.04
<b>FCC ID:</b>	BCG-E3086A

**Identification of Equipment Under Test (continued)**

<b>Brand Name:</b>	Apple
<b>Model Name or Number:</b>	A1779
<b>Test Sample Serial Number:</b>	C7CRG02QH6DH ( <i>Conducted Sample #3</i> )
<b>Hardware Version Number:</b>	REV1.0
<b>Software Version Number:</b>	iOS: 14A241z BB FW: 0.16.04
<b>FCC ID:</b>	BCG-E3086A

**3.2. Description of EUT**

The Equipment Under Test was a mobile phone with GSM/GPRS/EGPRS/UMTS/LTE/TD-SCDMA and CDMA technologies. It also supports IEEE 802.11a/b/g/n/ac, Bluetooth®, GPS and NFC. The rechargeable battery is not user accessible.

**3.3. Modifications Incorporated in the EUT**

No modifications were applied to the EUT during testing.

**3.4. Additional Information Related to Testing**

<b>Tested Technology:</b>	LTE Band 7		
<b>Type of Equipment</b>	Transceiver		
<b>Channel Bandwidth:</b>	5 MHz, 10 MHz, 15 MHz & 20 MHz		
<b>Modulation Type:</b>	QPSK & 16QAM		
<b>Duty Cycle:</b>	100%		
<b>Antenna Type:</b>	Integral		
<b>Antenna Gain (LAT):</b>	1.56 dBi		
<b>Antenna Gain (UAT):</b>	0.48 dBi		
<b>Power Supply Requirement:</b>	Nominal	3.8 VDC	
	Minimum	3.5 VDC	
	Maximum	4.4 VDC	
<b>Transmit Frequency Range:</b>	2500 MHz to 2570 MHz		
<b>Channels Tested:</b>	<b>Channel Bandwidth (MHz)</b>	<b>N<sub>ul</sub></b>	<b>Frequency of Uplink (MHz)</b>
<b>Bottom Channel</b>	5	20775	2502.5
	10	20800	2505.0
	15	20825	2507.5
	20	20850	2510.0
<b>Middle Channel</b>	All	21100	2535.0
<b>Top Channel</b>	5	21425	2567.5
	10	21400	2565.0
	15	21375	2562.5
	20	21350	2560.0

### **3.5. Support Equipment**

The following support equipment was used to exercise the EUT during testing:

<b>Description:</b>	Laptop PC
<b>Brand Name:</b>	Dell
<b>Model Name or Number:</b>	Latitude E5410
<b>Serial Number:</b>	UL Asset No. 00763

<b>Description:</b>	USB diagnostic cable
<b>Brand Name:</b>	Not stated
<b>Model Name or Number:</b>	Kong
<b>Serial Number:</b>	202D5E

<b>Description:</b>	Personal Hands Free (PHF)
<b>Brand Name:</b>	Apple
<b>Model Name or Number:</b>	Apple Ear Plugs
<b>Serial Number:</b>	Not stated

## **4. Operation and Monitoring of the EUT during Testing**

### **4.1. Operating Modes**

The EUT was tested in the following operating mode(s):

- Transmit Mode - The EUT was set to transmit with maximum output power using the required channel bandwidth. QPSK and 16QAM modulations were both tested, with Resource Block allocation as detailed in section 4.3.

### **4.2. Configuration and Peripherals**

The EUT was tested in the following configuration(s):

- The EUT was placed into a non-ui mode by using the teraterm application on a UL laptop PC. Instructions were provided by the customer to enable the baseband and radio (*Cellular\_RSE\_setup\_V3.0.doc*). This enabled the EUT to connect via a radiated link with the Rohde & Schwarz CMW 500 system simulator operating in transceiver mode. The CMW 500 was used to configure the EUT operating mode.
- The device contains two cellular antennas which do not transmit simultaneously.
  - LAT – Lower Antenna (Primary)
  - UAT – Upper Antenna (Secondary)

Both antennas have been tested to demonstrate compliance.

- For the LAT conducted measurements, the RF conducted port was connected with an external RF cable, supplied by the customer.
- For the UAT conducted cellular measurements, the RF conducted port was exposed and extended with a short RF cable supplied by the customer.
- Conducted measurements at temperature and voltage extremes were performed using a conducted sample supplied by the customer. Short DC flying leads were connected internally to the device in place of the battery, and exited through a hole in the casing. These leads were then extended to a DC power supply for testing purposes.
- The EUT was placed in three orthogonal orientations X, Y and Z to determine the worst case orientation for radiated spurious emissions. The worst case orientation for the LAT was Z and for the UAT was X.
- Transmitter radiated spurious emissions tests were performed with the EUT set to transmit with a 10 MHz channel bandwidth with QPSK modulation applied and 1 resource block with 0 offset. This was found to be the worst case modulation scheme with regards to emissions after preliminary investigations and therefore it was deemed to be the worst case.
- The worst-case radiated emission among all accessories, is determined by the manufacturer to be with the headset connected. The compliance lab performed final testing only with the headset attached.
- Transmitter radiated spurious emissions tests were performed with the PHF connected to the EUT.

### **4.3. Resource Block Allocation**

Channel Bandwidth (MHz)	Maximum No. of Resource Blocks	Resource Block / Offset Number					
		Sub Test 1		Sub Test 2		Sub Test 3	
		RB	Offset	RB	Offset	RB	Offset
5	25	1	0	1	24	25	0
10	50	1	0	1	49	50	0
15	75	1	0	1	74	75	0
20	100	1	0	1	99	100	0

Transmitter Occupied Bandwidth was carried out using sub test 3, for both QPSK and 16QAM modulation schemes.

Transmitter radiated spurious emissions tests were performed with the EUT set to transmit with a 10 MHz channel bandwidth with QPSK modulation applied and 1 resource block with 0 offset. This was found to be the worst case modulation scheme with regards to emissions after preliminary investigations and therefore it was deemed to be the worst case.

Transmitter Radiated Band Edge Emissions was tested with sub tests 1, 2 and 3 on all supported channel bandwidths using QPSK and 16-QAM modulations.

Transmitter Frequency Stability test was carried out with sub test 3, with a channel bandwidth of 5 MHz only.

## **5. Measurements, Examinations and Derived Results**

### **5.1. General Comments**

Measurement uncertainties are evaluated in accordance with current best practice. Our reported expanded uncertainties are based on standard uncertainties, which are multiplied by an appropriate coverage factor to provide a statistical confidence level of approximately 95%. Please refer to *Section 6* for Measurement Uncertainty details.

In accordance with UKAS requirements all the measurement equipment is on a calibration schedule. All equipment was within the calibration period on the date of testing.

**5.2. Test Results**

**5.2.1. Transmitter Output Power (EIRP) - LAT**

**Test Summary:**

<b>Test Engineer:</b>	Keith Tucker	<b>Test Date:</b>	18 July 2016
<b>Test Sample IMEI:</b>	358640070066221		

<b>FCC Reference:</b>	Parts 2.1046 & 27.50(h)(2)
<b>Test Method Used:</b>	KDB 971168 Section 2.2 footnote 1, Section 5.6 & Notes below

**Environmental Conditions:**

<b>Temperature (°C):</b>	23
<b>Relative Humidity (%):</b>	53

**Note(s):**

1. The customer stated that the antenna gain is 1.56 dBi. The antenna gain was added to the conducted output power to obtain the EIRP.
2. Measurements were performed with the EUT transmitting with QPSK and 16QAM modulation schemes, with resource blocks settings as detailed.
3. Conducted average power was measured using a calibrated Rohde and Schwarz CMW 500 Wideband Radio Communication Tester.
4. The RF port of the EUT was connected to the Communication Tester via an RF cable and suitable attenuation. An RF level offset was entered on the Communication Tester to compensate for the loss of the attenuator and RF cable.

**Test setup:**

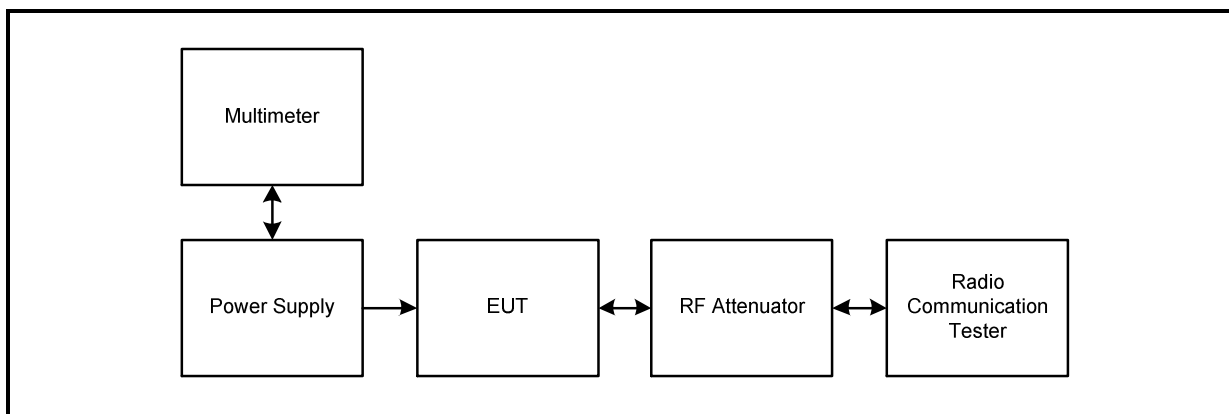

**Transmitter Output Power (EIRP) (continued)****Results: 5 MHz Channel Bandwidth / Bottom Channel / QPSK**

Frequency (MHz)	Resource Block(s)	Resource Block Offset	Conducted RF Power (dBm)	Antenna Gain (dBi)	EIRP (dBm)	EIRP Limit (dBm)	Margin (dB)	Result
2502.5	25	0	23.1	1.56	24.66	33.01	8.35	Complied
2502.5	12	13	23.1	1.56	24.66	33.01	8.35	Complied
2502.5	12	0	23.1	1.56	24.66	33.01	8.35	Complied
2502.5	12	7	23.1	1.56	24.66	33.01	8.35	Complied
2502.5	1	24	23.5	1.56	25.06	33.01	7.95	Complied
2502.5	1	0	23.5	1.56	25.06	33.01	7.95	Complied
2502.5	1	12	23.5	1.56	25.06	33.01	7.95	Complied

**Results: 5 MHz Channel Bandwidth / Bottom Channel / 16QAM**

Frequency (MHz)	Resource Block(s)	Resource Block Offset	Conducted RF Power (dBm)	Antenna Gain (dBi)	EIRP (dBm)	EIRP Limit (dBm)	Margin (dB)	Result
2502.5	25	0	22.0	1.56	23.56	33.01	9.45	Complied
2502.5	12	13	22.1	1.56	23.66	33.01	9.35	Complied
2502.5	12	0	22.1	1.56	23.66	33.01	9.35	Complied
2502.5	12	7	22.1	1.56	23.66	33.01	9.35	Complied
2502.5	1	24	23.5	1.56	25.06	33.01	7.95	Complied
2502.5	1	0	23.4	1.56	24.96	33.01	8.05	Complied
2502.5	1	12	23.4	1.56	24.96	33.01	8.05	Complied

**Results: 5 MHz Channel Bandwidth / Middle Channel / QPSK**

Frequency (MHz)	Resource Block(s)	Resource Block Offset	Conducted RF Power (dBm)	Antenna Gain (dBi)	EIRP (dBm)	EIRP Limit (dBm)	Margin (dB)	Result
2535.0	25	0	23.1	1.56	24.66	33.01	8.35	Complied
2535.0	12	13	23.0	1.56	24.56	33.01	8.45	Complied
2535.0	12	0	23.1	1.56	24.66	33.01	8.35	Complied
2535.0	12	7	23.0	1.56	24.56	33.01	8.45	Complied
2535.0	1	24	23.5	1.56	25.06	33.01	7.95	Complied
2535.0	1	0	23.6	1.56	25.16	33.01	7.85	Complied
2535.0	1	12	23.4	1.56	24.96	33.01	8.05	Complied

**Transmitter Output Power (EIRP) (continued)****Results: 5 MHz Channel Bandwidth / Middle Channel / 16QAM**

Frequency (MHz)	Resource Block(s)	Resource Block Offset	Conducted RF Power (dBm)	Antenna Gain (dBi)	EIRP (dBm)	EIRP Limit (dBm)	Margin (dB)	Result
2535.0	25	0	22.1	1.56	23.66	33.01	9.35	Complied
2535.0	12	13	22.0	1.56	23.56	33.01	9.45	Complied
2535.0	12	0	22.0	1.56	23.56	33.01	9.45	Complied
2535.0	12	7	22.0	1.56	23.56	33.01	9.45	Complied
2535.0	1	24	23.1	1.56	24.66	33.01	8.35	Complied
2535.0	1	0	23.2	1.56	24.76	33.01	8.25	Complied
2535.0	1	12	23.0	1.56	24.56	33.01	8.45	Complied

**Results: 5 MHz Channel Bandwidth / Top Channel / QPSK**

Frequency (MHz)	Resource Block(s)	Resource Block Offset	Conducted RF Power (dBm)	Antenna Gain (dBi)	EIRP (dBm)	EIRP Limit (dBm)	Margin (dB)	Result
2567.5	25	0	22.9	1.56	24.46	33.01	8.55	Complied
2567.5	12	13	22.8	1.56	24.36	33.01	8.65	Complied
2567.5	12	0	22.8	1.56	24.36	33.01	8.65	Complied
2567.5	12	7	22.8	1.56	24.36	33.01	8.65	Complied
2567.5	1	24	23.3	1.56	24.86	33.01	8.15	Complied
2567.5	1	0	23.3	1.56	24.86	33.01	8.15	Complied
2567.5	1	12	23.4	1.56	24.96	33.01	8.05	Complied

**Results: 5 MHz Channel Bandwidth / Top Channel / 16QAM**

Frequency (MHz)	Resource Block(s)	Resource Block Offset	Conducted RF Power (dBm)	Antenna Gain (dBi)	EIRP (dBm)	EIRP Limit (dBm)	Margin (dB)	Result
2567.5	25	0	21.7	1.56	23.26	33.01	9.75	Complied
2567.5	12	13	21.8	1.56	23.36	33.01	9.65	Complied
2567.5	12	0	21.8	1.56	23.36	33.01	9.65	Complied
2567.5	12	7	21.8	1.56	23.36	33.01	9.65	Complied
2567.5	1	24	22.7	1.56	24.26	33.01	8.75	Complied
2567.5	1	0	22.7	1.56	24.26	33.01	8.75	Complied
2567.5	1	12	22.7	1.56	24.26	33.01	8.75	Complied

**Transmitter Output Power (EIRP) (continued)****Results: 10 MHz Channel Bandwidth / Bottom Channel / QPSK**

Frequency (MHz)	Resource Block(s)	Resource Block Offset	Conducted RF Power (dBm)	Antenna Gain (dBi)	EIRP (dBm)	EIRP Limit (dBm)	Margin (dB)	Result
2505.0	50	0	23.2	1.56	24.76	33.01	8.25	Complied
2505.0	25	24	23.2	1.56	24.76	33.01	8.25	Complied
2505.0	25	0	23.3	1.56	24.86	33.01	8.15	Complied
2505.0	25	12	23.2	1.56	24.76	33.01	8.25	Complied
2505.0	1	49	23.5	1.56	25.06	33.01	7.95	Complied
2505.0	1	0	23.7	1.56	25.26	33.01	7.75	Complied
2505.0	1	24	23.5	1.56	25.06	33.01	7.95	Complied

**Results: 10 MHz Channel Bandwidth / Bottom Channel / 16QAM**

Frequency (MHz)	Resource Block(s)	Resource Block Offset	Conducted RF Power (dBm)	Antenna Gain (dBi)	EIRP (dBm)	EIRP Limit (dBm)	Margin (dB)	Result
2505.0	50	0	22.1	1.56	23.66	33.01	9.35	Complied
2505.0	25	24	22.2	1.56	23.76	33.01	9.25	Complied
2505.0	25	0	22.2	1.56	23.76	33.01	9.25	Complied
2505.0	25	12	22.2	1.56	23.76	33.01	9.25	Complied
2505.0	1	49	23.3	1.56	24.86	33.01	8.15	Complied
2505.0	1	0	23.4	1.56	24.96	33.01	8.05	Complied
2505.0	1	24	23.3	1.56	24.86	33.01	8.15	Complied

**Results: 10 MHz Channel Bandwidth / Middle Channel / QPSK**

Frequency (MHz)	Resource Block(s)	Resource Block Offset	Conducted RF Power (dBm)	Antenna Gain (dBi)	EIRP (dBm)	EIRP Limit (dBm)	Margin (dB)	Result
2535.0	50	0	23.1	1.56	24.66	33.01	8.35	Complied
2535.0	25	24	23.1	1.56	24.66	33.01	8.35	Complied
2535.0	25	0	23.2	1.56	24.76	33.01	8.25	Complied
2535.0	25	12	23.1	1.56	24.66	33.01	8.35	Complied
2535.0	1	49	23.4	1.56	24.96	33.01	8.05	Complied
2535.0	1	0	23.6	1.56	25.16	33.01	7.85	Complied
2535.0	1	24	23.4	1.56	24.96	33.01	8.05	Complied

**Transmitter Output Power (EIRP) (continued)****Results: 10 MHz Channel Bandwidth / Middle Channel / 16QAM**

Frequency (MHz)	Resource Block(s)	Resource Block Offset	Conducted RF Power (dBm)	Antenna Gain (dBi)	EIRP (dBm)	EIRP Limit (dBm)	Margin (dB)	Result
2535.0	50	0	22.1	1.56	23.66	33.01	9.35	Complied
2535.0	25	24	22.1	1.56	23.66	33.01	9.35	Complied
2535.0	25	0	22.2	1.56	23.76	33.01	9.25	Complied
2535.0	25	12	22.1	1.56	23.66	33.01	9.35	Complied
2535.0	1	49	23.0	1.56	24.56	33.01	8.45	Complied
2535.0	1	0	23.2	1.56	24.76	33.01	8.25	Complied
2535.0	1	24	23.0	1.56	24.56	33.01	8.45	Complied

**Results: 10 MHz Channel Bandwidth / Top Channel / QPSK**

Frequency (MHz)	Resource Block(s)	Resource Block Offset	Conducted RF Power (dBm)	Antenna Gain (dBi)	EIRP (dBm)	EIRP Limit (dBm)	Margin (dB)	Result
2565.0	50	0	23.0	1.56	24.56	33.01	8.45	Complied
2565.0	25	24	23.0	1.56	24.56	33.01	8.45	Complied
2565.0	25	0	23.1	1.56	24.66	33.01	8.35	Complied
2565.0	25	12	23.0	1.56	24.56	33.01	8.45	Complied
2565.0	1	49	23.4	1.56	24.96	33.01	8.05	Complied
2565.0	1	0	23.6	1.56	25.16	33.01	7.85	Complied
2565.0	1	24	23.4	1.56	24.96	33.01	8.05	Complied

**Results: 10 MHz Channel Bandwidth / Top Channel / 16QAM**

Frequency (MHz)	Resource Block(s)	Resource Block Offset	Conducted RF Power (dBm)	Antenna Gain (dBi)	EIRP (dBm)	EIRP Limit (dBm)	Margin (dB)	Result
2565.0	50	0	22.0	1.56	23.56	33.01	9.45	Complied
2565.0	25	24	22.0	1.56	23.56	33.01	9.45	Complied
2565.0	25	0	22.0	1.56	23.56	33.01	9.45	Complied
2565.0	25	12	22.0	1.56	23.56	33.01	9.45	Complied
2565.0	1	49	23.4	1.56	24.96	33.01	8.05	Complied
2565.0	1	0	23.6	1.56	25.16	33.01	7.85	Complied
2565.0	1	24	23.3	1.56	24.86	33.01	8.15	Complied

**Transmitter Output Power (EIRP) (continued)****Results: 15 MHz Channel Bandwidth / Bottom Channel / QPSK**

Frequency (MHz)	Resource Block(s)	Resource Block Offset	Conducted RF Power (dBm)	Antenna Gain (dBi)	EIRP (dBm)	EIRP Limit (dBm)	Margin (dB)	Result
2507.5	75	0	23.2	1.56	24.76	33.01	8.25	Complied
2507.5	36	37	23.1	1.56	24.66	33.01	8.35	Complied
2507.5	36	0	23.2	1.56	24.76	33.01	8.25	Complied
2507.5	36	18	23.2	1.56	24.76	33.01	8.25	Complied
2507.5	1	74	23.5	1.56	25.06	33.01	7.95	Complied
2507.5	1	0	23.8	1.56	25.36	33.01	7.65	Complied
2507.5	1	36	23.6	1.56	25.16	33.01	7.85	Complied

**Results: 15 MHz Channel Bandwidth / Bottom Channel / 16QAM**

Frequency (MHz)	Resource Block(s)	Resource Block Offset	Conducted RF Power (dBm)	Antenna Gain (dBi)	EIRP (dBm)	EIRP Limit (dBm)	Margin (dB)	Result
2507.5	75	0	22.1	1.56	23.66	33.01	9.35	Complied
2507.5	36	37	22.1	1.56	23.66	33.01	9.35	Complied
2507.5	36	0	22.3	1.56	23.86	33.01	9.15	Complied
2507.5	36	18	22.2	1.56	23.76	33.01	9.25	Complied
2507.5	1	74	23.1	1.56	24.66	33.01	8.35	Complied
2507.5	1	0	23.4	1.56	24.96	33.01	8.05	Complied
2507.5	1	36	23.3	1.56	24.86	33.01	8.15	Complied

**Results: 15 MHz Channel Bandwidth / Middle Channel / QPSK**

Frequency (MHz)	Resource Block(s)	Resource Block Offset	Conducted RF Power (dBm)	Antenna Gain (dBi)	EIRP (dBm)	EIRP Limit (dBm)	Margin (dB)	Result
2535.0	75	0	23.2	1.56	24.76	33.01	8.25	Complied
2535.0	36	37	23.0	1.56	24.56	33.01	8.45	Complied
2535.0	36	0	23.3	1.56	24.86	33.01	8.15	Complied
2535.0	36	18	23.2	1.56	24.76	33.01	8.25	Complied
2535.0	1	74	23.6	1.56	25.16	33.01	7.85	Complied
2535.0	1	0	23.8	1.56	25.36	33.01	7.65	Complied
2535.0	1	36	23.6	1.56	25.16	33.01	7.85	Complied

**Transmitter Output Power (EIRP) (continued)****Results: 15 MHz Channel Bandwidth / Middle Channel / 16QAM**

Frequency (MHz)	Resource Block(s)	Resource Block Offset	Conducted RF Power (dBm)	Antenna Gain (dBi)	EIRP (dBm)	EIRP Limit (dBm)	Margin (dB)	Result
2535.0	75	0	22.2	1.56	23.76	33.01	9.25	Complied
2535.0	36	37	22.1	1.56	23.66	33.01	9.35	Complied
2535.0	36	0	22.3	1.56	23.86	33.01	9.15	Complied
2535.0	36	18	22.2	1.56	23.76	33.01	9.25	Complied
2535.0	1	74	23.5	1.56	25.06	33.01	7.95	Complied
2535.0	1	0	23.8	1.56	25.36	33.01	7.65	Complied
2535.0	1	36	23.5	1.56	25.06	33.01	7.95	Complied

**Results: 15 MHz Channel Bandwidth / Top Channel / QPSK**

Frequency (MHz)	Resource Block(s)	Resource Block Offset	Conducted RF Power (dBm)	Antenna Gain (dBi)	EIRP (dBm)	EIRP Limit (dBm)	Margin (dB)	Result
2562.5	75	0	23.1	1.56	24.66	33.01	8.35	Complied
2562.5	36	37	22.9	1.56	24.46	33.01	8.55	Complied
2562.5	36	0	23.1	1.56	24.66	33.01	8.35	Complied
2562.5	36	18	23.1	1.56	24.66	33.01	8.35	Complied
2562.5	1	74	23.4	1.56	24.96	33.01	8.05	Complied
2562.5	1	0	23.7	1.56	25.26	33.01	7.75	Complied
2562.5	1	36	23.5	1.56	25.06	33.01	7.95	Complied

**Results: 15 MHz Channel Bandwidth / Top Channel / 16QAM**

Frequency (MHz)	Resource Block(s)	Resource Block Offset	Conducted RF Power (dBm)	Antenna Gain (dBi)	EIRP (dBm)	EIRP Limit (dBm)	Margin (dB)	Result
2562.5	75	0	22.1	1.56	23.66	33.01	9.35	Complied
2562.5	36	37	21.9	1.56	23.46	33.01	9.55	Complied
2562.5	36	0	22.1	1.56	23.66	33.01	9.35	Complied
2562.5	36	18	22.1	1.56	23.66	33.01	9.35	Complied
2562.5	1	74	23.2	1.56	24.76	33.01	8.25	Complied
2562.5	1	0	23.8	1.56	25.36	33.01	7.65	Complied
2562.5	1	36	23.5	1.56	25.06	33.01	7.95	Complied

**Transmitter Output Power (EIRP) (continued)****Results: 20 MHz Channel Bandwidth / Bottom Channel / QPSK**

Frequency (MHz)	Resource Block(s)	Resource Block Offset	Conducted RF Power (dBm)	Antenna Gain (dBi)	EIRP (dBm)	EIRP Limit (dBm)	Margin (dB)	Result
2510.0	100	0	23.3	1.56	24.86	33.01	8.15	Complied
2510.0	50	49	23.1	1.56	24.66	33.01	8.35	Complied
2510.0	50	0	23.3	1.56	24.86	33.01	8.15	Complied
2510.0	50	24	23.3	1.56	24.86	33.01	8.15	Complied
2510.0	1	99	23.6	1.56	25.16	33.01	7.85	Complied
2510.0	1	0	24.0	1.56	25.56	33.01	7.45	Complied
2510.0	1	49	23.6	1.56	25.16	33.01	7.85	Complied

**Results: 20 MHz Channel Bandwidth / Bottom Channel / 16QAM**

Frequency (MHz)	Resource Block(s)	Resource Block Offset	Conducted RF Power (dBm)	Antenna Gain (dBi)	EIRP (dBm)	EIRP Limit (dBm)	Margin (dB)	Result
2510.0	100	0	22.2	1.56	23.76	33.01	9.25	Complied
2510.0	50	49	22.1	1.56	23.66	33.01	9.35	Complied
2510.0	50	0	22.6	1.56	24.16	33.01	8.85	Complied
2510.0	50	24	22.1	1.56	23.66	33.01	9.35	Complied
2510.0	1	99	23.2	1.56	24.76	33.01	8.25	Complied
2510.0	1	0	23.6	1.56	25.16	33.01	7.85	Complied
2510.0	1	49	23.4	1.56	24.96	33.01	8.05	Complied

**Results: 20 MHz Channel Bandwidth / Middle Channel / QPSK**

Frequency (MHz)	Resource Block(s)	Resource Block Offset	Conducted RF Power (dBm)	Antenna Gain (dBi)	EIRP (dBm)	EIRP Limit (dBm)	Margin (dB)	Result
2535.0	100	0	23.3	1.56	24.86	33.01	8.15	Complied
2535.0	50	49	23.5	1.56	25.06	33.01	7.95	Complied
2535.0	50	0	23.5	1.56	25.06	33.01	7.95	Complied
2535.0	50	24	23.3	1.56	24.86	33.01	8.15	Complied
2535.0	1	99	23.7	1.56	25.26	33.01	7.75	Complied
2535.0	1	0	24.0	1.56	25.56	33.01	7.45	Complied
2535.0	1	49	23.7	1.56	25.26	33.01	7.75	Complied

**Transmitter Output Power (EIRP) (continued)****Results: 20 MHz Channel Bandwidth / Middle Channel / 16QAM**

Frequency (MHz)	Resource Block(s)	Resource Block Offset	Conducted RF Power (dBm)	Antenna Gain (dBi)	EIRP (dBm)	EIRP Limit (dBm)	Margin (dB)	Result
2535.0	100	0	22.7	1.56	24.26	33.01	8.75	Complied
2535.0	50	49	22.7	1.56	24.26	33.01	8.75	Complied
2535.0	50	0	22.8	1.56	24.36	33.01	8.65	Complied
2535.0	50	24	22.6	1.56	24.16	33.01	8.85	Complied
2535.0	1	99	23.5	1.56	25.06	33.01	7.95	Complied
2535.0	1	0	24.0	1.56	25.56	33.01	7.45	Complied
2535.0	1	49	23.7	1.56	25.26	33.01	7.75	Complied

**Results: 20 MHz Channel Bandwidth / Top Channel / QPSK**

Frequency (MHz)	Resource Block(s)	Resource Block Offset	Conducted RF Power (dBm)	Antenna Gain (dBi)	EIRP (dBm)	EIRP Limit (dBm)	Margin (dB)	Result
2560.0	100	0	23.1	1.56	24.66	33.01	8.35	Complied
2560.0	50	49	22.9	1.56	24.46	33.01	8.55	Complied
2560.0	50	0	23.2	1.56	24.76	33.01	8.25	Complied
2560.0	50	24	23.1	1.56	24.66	33.01	8.35	Complied
2560.0	1	99	23.3	1.56	24.86	33.01	8.15	Complied
2560.0	1	0	23.8	1.56	25.36	33.01	7.65	Complied
2560.0	1	49	23.5	1.56	25.06	33.01	7.95	Complied

**Results: 20 MHz Channel Bandwidth / Top Channel / 16QAM**

Frequency (MHz)	Resource Block(s)	Resource Block Offset	Conducted RF Power (dBm)	Antenna Gain (dBi)	EIRP (dBm)	EIRP Limit (dBm)	Margin (dB)	Result
2560.0	100	0	22.1	1.56	23.66	33.01	9.35	Complied
2560.0	50	49	21.9	1.56	23.46	33.01	9.55	Complied
2560.0	50	0	22.2	1.56	23.76	33.01	9.25	Complied
2560.0	50	24	22.1	1.56	23.66	33.01	9.35	Complied
2560.0	1	99	23.3	1.56	24.86	33.01	8.15	Complied
2560.0	1	0	23.7	1.56	25.26	33.01	7.75	Complied
2560.0	1	49	23.3	1.56	24.86	33.01	8.15	Complied

**Transmitter Output Power (EIRP) (continued)****Test Equipment Used:**

Asset No.	Instrument	Manufacturer	Type No.	Serial No.	Date Calibration Due	Cal. Interval (Months)
M2002	Thermohygrometer	Testo	608-H1	45041825	02 Apr 2017	12
M1869	Wideband Radio Comms Tester	Rohde & Schwarz	CMW500	145923	05 Apr 2017	12
A2845	Attenuator	Radiall	R411.806.121	24325927	Calibrated before use	-
A2844	Attenuator	Radiall	R411.803.121	23404066	Calibrated before use	-
S0562	Power Supply	Thurlby Thandar	PL330QMD	054895	Calibrated before use	-
M1269	Multimeter	Fluke	179	90250210	13 May 2017	12
G0628	Signal Generator	Rohde & Schwarz	SMBV100A	261847	25 Jan 2017	12
M1835	Signal Analyser	Rohde & Schwarz	FSV30	103050	26 Feb 2017	12

**5.2.2. Transmitter Output Power (EIRP) - UAT****Test Summary:**

<b>Test Engineer:</b>	Keith Tucker	<b>Test Date:</b>	19 July 2016
<b>Test Sample IMEI:</b>	358640070066221		

<b>FCC Reference:</b>	Parts 2.1046 & 27.50(h)(2)
<b>Test Method Used:</b>	KDB 971168 Section 2.2 footnote 1, Section 5.6 & Notes below

**Environmental Conditions:**

<b>Temperature (°C):</b>	24
<b>Relative Humidity (%):</b>	46

**Note(s):**

1. The customer stated that the antenna gain is 0.48 dBi. The antenna gain was added to the conducted output power to obtain the EIRP.
2. Measurements were performed with the EUT transmitting with QPSK and 16QAM modulation schemes, with resource blocks settings as detailed.
3. Conducted average power was measured using a calibrated Rohde and Schwarz CMW 500 Wideband Radio Communication Tester.
4. The RF port of the EUT was connected to the Communication Tester via an RF cable and suitable attenuation. An RF level offset was entered on the Communication Tester to compensate for the loss of the attenuator and RF cable.

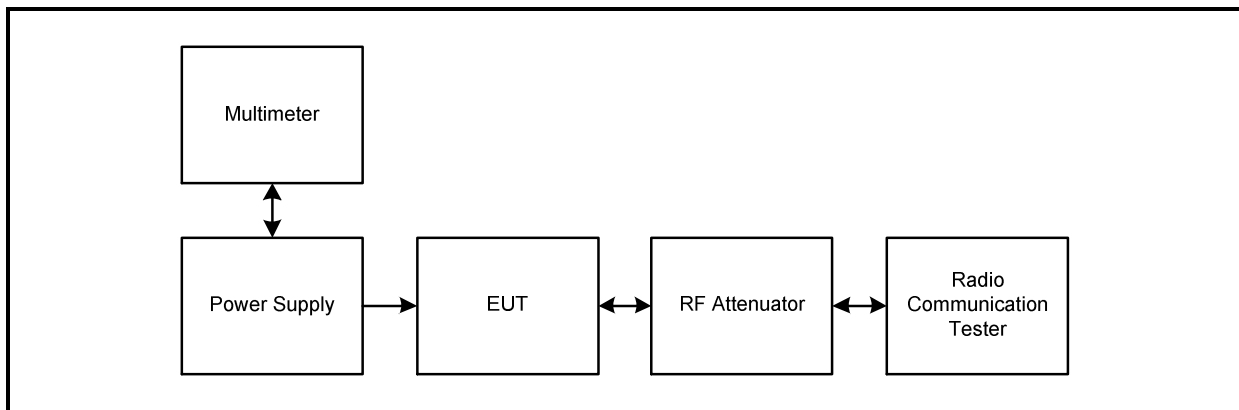
**Test setup:**

**Transmitter Output Power (EIRP) (continued)****Results: 5 MHz Channel Bandwidth / Bottom Channel / QPSK**

Frequency (MHz)	Resource Block(s)	Resource Block Offset	Conducted RF Power (dBm)	Antenna Gain (dBi)	EIRP (dBm)	EIRP Limit (dBm)	Margin (dB)	Result
2502.5	25	0	15.1	0.48	15.58	33.01	17.43	Complied
2502.5	12	13	15.2	0.48	15.68	33.01	17.33	Complied
2502.5	12	0	15.0	0.48	15.48	33.01	17.53	Complied
2502.5	12	7	15.2	0.48	15.68	33.01	17.33	Complied
2502.5	1	24	16.4	0.48	16.88	33.01	16.13	Complied
2502.5	1	0	15.9	0.48	16.38	33.01	16.63	Complied
2502.5	1	12	16.3	0.48	16.78	33.01	16.23	Complied

**Results: 5 MHz Channel Bandwidth / Bottom Channel / 16QAM**

Frequency (MHz)	Resource Block(s)	Resource Block Offset	Conducted RF Power (dBm)	Antenna Gain (dBi)	EIRP (dBm)	EIRP Limit (dBm)	Margin (dB)	Result
2502.5	25	0	14.1	0.48	14.58	33.01	18.43	Complied
2502.5	12	13	14.3	0.48	14.78	33.01	18.23	Complied
2502.5	12	0	14.0	0.48	14.48	33.01	18.53	Complied
2502.5	12	7	14.2	0.48	14.68	33.01	18.33	Complied
2502.5	1	24	15.3	0.48	15.78	33.01	17.23	Complied
2502.5	1	0	14.7	0.48	15.18	33.01	17.83	Complied
2502.5	1	12	15.1	0.48	15.58	33.01	17.43	Complied

**Results: 5 MHz Channel Bandwidth / Middle Channel / QPSK**

Frequency (MHz)	Resource Block(s)	Resource Block Offset	Conducted RF Power (dBm)	Antenna Gain (dBi)	EIRP (dBm)	EIRP Limit (dBm)	Margin (dB)	Result
2535.0	25	0	15.4	0.48	15.88	33.01	17.13	Complied
2535.0	12	13	15.3	0.48	15.78	33.01	17.23	Complied
2535.0	12	0	15.4	0.48	15.88	33.01	17.13	Complied
2535.0	12	7	15.4	0.48	15.88	33.01	17.13	Complied
2535.0	1	24	16.4	0.48	16.88	33.01	16.13	Complied
2535.0	1	0	16.5	0.48	16.98	33.01	16.03	Complied
2535.0	1	12	16.4	0.48	16.88	33.01	16.13	Complied

**Transmitter Output Power (EIRP) (continued)****Results: 5 MHz Channel Bandwidth / Middle Channel / 16QAM**

Frequency (MHz)	Resource Block(s)	Resource Block Offset	Conducted RF Power (dBm)	Antenna Gain (dBi)	EIRP (dBm)	EIRP Limit (dBm)	Margin (dB)	Result
2535.0	25	0	14.4	0.48	14.88	33.01	18.13	Complied
2535.0	12	13	14.4	0.48	14.88	33.01	18.13	Complied
2535.0	12	0	14.4	0.48	14.88	33.01	18.13	Complied
2535.0	12	7	14.4	0.48	14.88	33.01	18.13	Complied
2535.0	1	24	15.6	0.48	16.08	33.01	16.93	Complied
2535.0	1	0	15.7	0.48	16.18	33.01	16.83	Complied
2535.0	1	12	15.6	0.48	16.08	33.01	16.93	Complied

**Results: 5 MHz Channel Bandwidth / Top Channel / QPSK**

Frequency (MHz)	Resource Block(s)	Resource Block Offset	Conducted RF Power (dBm)	Antenna Gain (dBi)	EIRP (dBm)	EIRP Limit (dBm)	Margin (dB)	Result
2567.5	25	0	15.2	0.48	15.68	33.01	17.33	Complied
2567.5	12	13	15.1	0.48	15.58	33.01	17.43	Complied
2567.5	12	0	15.2	0.48	15.68	33.01	17.33	Complied
2567.5	12	7	15.2	0.48	15.68	33.01	17.33	Complied
2567.5	1	24	16.2	0.48	16.68	33.01	16.33	Complied
2567.5	1	0	16.3	0.48	16.78	33.01	16.23	Complied
2567.5	1	12	16.2	0.48	16.68	33.01	16.33	Complied

**Results: 5 MHz Channel Bandwidth / Top Channel / 16QAM**

Frequency (MHz)	Resource Block(s)	Resource Block Offset	Conducted RF Power (dBm)	Antenna Gain (dBi)	EIRP (dBm)	EIRP Limit (dBm)	Margin (dB)	Result
2567.5	25	0	14.2	0.48	14.68	33.01	18.33	Complied
2567.5	12	13	14.1	0.48	14.58	33.01	18.43	Complied
2567.5	12	0	14.1	0.48	14.58	33.01	18.43	Complied
2567.5	12	7	14.1	0.48	14.58	33.01	18.43	Complied
2567.5	1	24	15.2	0.48	15.68	33.01	17.33	Complied
2567.5	1	0	15.3	0.48	15.78	33.01	17.23	Complied
2567.5	1	12	15.2	0.48	15.68	33.01	17.33	Complied

**Transmitter Output Power (EIRP) (continued)****Results: 10 MHz Channel Bandwidth / Bottom Channel / QPSK**

Frequency (MHz)	Resource Block(s)	Resource Block Offset	Conducted RF Power (dBm)	Antenna Gain (dBi)	EIRP (dBm)	EIRP Limit (dBm)	Margin (dB)	Result
2505.0	50	0	15.4	0.48	15.88	33.01	17.13	Complied
2505.0	25	24	15.5	0.48	15.98	33.01	17.03	Complied
2505.0	25	0	15.3	0.48	15.78	33.01	17.23	Complied
2505.0	25	12	15.4	0.48	15.88	33.01	17.13	Complied
2505.0	1	49	16.7	0.48	17.18	33.01	15.83	Complied
2505.0	1	0	16.0	0.48	16.48	33.01	16.53	Complied
2505.0	1	24	16.3	0.48	16.78	33.01	16.23	Complied

**Results: 10 MHz Channel Bandwidth / Bottom Channel / 16QAM**

Frequency (MHz)	Resource Block(s)	Resource Block Offset	Conducted RF Power (dBm)	Antenna Gain (dBi)	EIRP (dBm)	EIRP Limit (dBm)	Margin (dB)	Result
2505.0	50	0	14.4	0.48	14.88	33.01	18.13	Complied
2505.0	25	24	14.6	0.48	15.08	33.01	17.93	Complied
2505.0	25	0	14.3	0.48	14.78	33.01	18.23	Complied
2505.0	25	12	14.4	0.48	14.88	33.01	18.13	Complied
2505.0	1	49	15.8	0.48	16.28	33.01	16.73	Complied
2505.0	1	0	15.1	0.48	15.58	33.01	17.43	Complied
2505.0	1	24	15.5	0.48	15.98	33.01	17.03	Complied

**Results: 10 MHz Channel Bandwidth / Middle Channel / QPSK**

Frequency (MHz)	Resource Block(s)	Resource Block Offset	Conducted RF Power (dBm)	Antenna Gain (dBi)	EIRP (dBm)	EIRP Limit (dBm)	Margin (dB)	Result
2535.0	50	0	15.5	0.48	15.98	33.01	17.03	Complied
2535.0	25	24	15.4	0.48	15.88	33.01	17.13	Complied
2535.0	25	0	15.6	0.48	16.08	33.01	16.93	Complied
2535.0	25	12	15.4	0.48	15.88	33.01	17.13	Complied
2535.0	1	49	16.4	0.48	16.88	33.01	16.13	Complied
2535.0	1	0	16.7	0.48	17.18	33.01	15.83	Complied
2535.0	1	24	16.3	0.48	16.78	33.01	16.23	Complied

**Transmitter Output Power (EIRP) (continued)****Results: 10 MHz Channel Bandwidth / Middle Channel / 16QAM**

Frequency (MHz)	Resource Block(s)	Resource Block Offset	Conducted RF Power (dBm)	Antenna Gain (dBi)	EIRP (dBm)	EIRP Limit (dBm)	Margin (dB)	Result
2535.0	50	0	14.4	0.48	14.88	33.01	18.13	Complied
2535.0	25	24	14.4	0.48	14.88	33.01	18.13	Complied
2535.0	25	0	14.6	0.48	15.08	33.01	17.93	Complied
2535.0	25	12	14.5	0.48	14.98	33.01	18.03	Complied
2535.0	1	49	15.4	0.48	15.88	33.01	17.13	Complied
2535.0	1	0	15.7	0.48	16.18	33.01	16.83	Complied
2535.0	1	24	15.4	0.48	15.88	33.01	17.13	Complied

**Results: 10 MHz Channel Bandwidth / Top Channel / QPSK**

Frequency (MHz)	Resource Block(s)	Resource Block Offset	Conducted RF Power (dBm)	Antenna Gain (dBi)	EIRP (dBm)	EIRP Limit (dBm)	Margin (dB)	Result
2565.0	50	0	15.3	0.48	15.78	33.01	17.23	Complied
2565.0	25	24	15.2	0.48	15.68	33.01	17.33	Complied
2565.0	25	0	15.3	0.48	15.78	33.01	17.23	Complied
2565.0	25	12	15.2	0.48	15.68	33.01	17.33	Complied
2565.0	1	49	16.1	0.48	16.58	33.01	16.43	Complied
2565.0	1	0	16.3	0.48	16.78	33.01	16.23	Complied
2565.0	1	24	16.1	0.48	16.58	33.01	16.43	Complied

**Results: 10 MHz Channel Bandwidth / Top Channel / 16QAM**

Frequency (MHz)	Resource Block(s)	Resource Block Offset	Conducted RF Power (dBm)	Antenna Gain (dBi)	EIRP (dBm)	EIRP Limit (dBm)	Margin (dB)	Result
2565.0	50	0	14.2	0.48	14.68	33.01	18.33	Complied
2565.0	25	24	14.2	0.48	14.68	33.01	18.33	Complied
2565.0	25	0	14.3	0.48	14.78	33.01	18.23	Complied
2565.0	25	12	14.3	0.48	14.78	33.01	18.23	Complied
2565.0	1	49	15.7	0.48	16.18	33.01	16.83	Complied
2565.0	1	0	15.9	0.48	16.38	33.01	16.63	Complied
2565.0	1	24	15.7	0.48	16.18	33.01	16.83	Complied

**Transmitter Output Power (EIRP) (continued)****Results: 15 MHz Channel Bandwidth / Bottom Channel / QPSK**

Frequency (MHz)	Resource Block(s)	Resource Block Offset	Conducted RF Power (dBm)	Antenna Gain (dBi)	EIRP (dBm)	EIRP Limit (dBm)	Margin (dB)	Result
2507.5	75	0	15.7	0.48	16.18	33.01	16.83	Complied
2507.5	36	37	15.7	0.48	16.18	33.01	16.83	Complied
2507.5	36	0	15.5	0.48	15.98	33.01	17.03	Complied
2507.5	36	18	15.7	0.48	16.18	33.01	16.83	Complied
2507.5	1	74	16.7	0.48	17.18	33.01	15.83	Complied
2507.5	1	0	16.2	0.48	16.68	33.01	16.33	Complied
2507.5	1	36	16.7	0.48	17.18	33.01	15.83	Complied

**Results: 15 MHz Channel Bandwidth / Bottom Channel / 16QAM**

Frequency (MHz)	Resource Block(s)	Resource Block Offset	Conducted RF Power (dBm)	Antenna Gain (dBi)	EIRP (dBm)	EIRP Limit (dBm)	Margin (dB)	Result
2507.5	75	0	14.7	0.48	15.18	33.01	17.83	Complied
2507.5	36	37	14.7	0.48	15.18	33.01	17.83	Complied
2507.5	36	0	14.5	0.48	14.98	33.01	18.03	Complied
2507.5	36	18	14.7	0.48	15.18	33.01	17.83	Complied
2507.5	1	74	15.8	0.48	16.28	33.01	16.73	Complied
2507.5	1	0	15.3	0.48	15.78	33.01	17.23	Complied
2507.5	1	36	15.8	0.48	16.28	33.01	16.73	Complied

**Results: 15 MHz Channel Bandwidth / Middle Channel / QPSK**

Frequency (MHz)	Resource Block(s)	Resource Block Offset	Conducted RF Power (dBm)	Antenna Gain (dBi)	EIRP (dBm)	EIRP Limit (dBm)	Margin (dB)	Result
2535.0	75	0	15.5	0.48	15.98	33.01	17.03	Complied
2535.0	36	37	15.4	0.48	15.88	33.01	17.13	Complied
2535.0	36	0	15.8	0.48	16.28	33.01	16.73	Complied
2535.0	36	18	15.5	0.48	15.98	33.01	17.03	Complied
2535.0	1	74	16.5	0.48	16.98	33.01	16.03	Complied
2535.0	1	0	16.9	0.48	17.38	33.01	15.63	Complied
2535.0	1	36	16.5	0.48	16.98	33.01	16.03	Complied

**Transmitter Output Power (EIRP) (continued)****Results: 15 MHz Channel Bandwidth / Middle Channel / 16QAM**

Frequency (MHz)	Resource Block(s)	Resource Block Offset	Conducted RF Power (dBm)	Antenna Gain (dBi)	EIRP (dBm)	EIRP Limit (dBm)	Margin (dB)	Result
2535.0	75	0	14.5	0.48	14.98	33.01	18.03	Complied
2535.0	36	37	14.4	0.48	14.88	33.01	18.13	Complied
2535.0	36	0	14.7	0.48	15.18	33.01	17.83	Complied
2535.0	36	18	14.5	0.48	14.98	33.01	18.03	Complied
2535.0	1	74	15.8	0.48	16.28	33.01	16.73	Complied
2535.0	1	0	16.2	0.48	16.68	33.01	16.33	Complied
2535.0	1	36	15.8	0.48	16.28	33.01	16.73	Complied

**Results: 15 MHz Channel Bandwidth / Top Channel / QPSK**

Frequency (MHz)	Resource Block(s)	Resource Block Offset	Conducted RF Power (dBm)	Antenna Gain (dBi)	EIRP (dBm)	EIRP Limit (dBm)	Margin (dB)	Result
2562.5	75	0	15.4	0.48	15.88	33.01	17.13	Complied
2562.5	36	37	15.2	0.48	15.68	33.01	17.33	Complied
2562.5	36	0	15.4	0.48	15.88	33.01	17.13	Complied
2562.5	36	18	15.3	0.48	15.78	33.01	17.23	Complied
2562.5	1	74	16.1	0.48	16.58	33.01	16.43	Complied
2562.5	1	0	16.6	0.48	17.08	33.01	15.93	Complied
2562.5	1	36	16.3	0.48	16.78	33.01	16.23	Complied

**Results: 15 MHz Channel Bandwidth / Top Channel / 16QAM**

Frequency (MHz)	Resource Block(s)	Resource Block Offset	Conducted RF Power (dBm)	Antenna Gain (dBi)	EIRP (dBm)	EIRP Limit (dBm)	Margin (dB)	Result
2562.5	75	0	14.4	0.48	14.88	33.01	18.13	Complied
2562.5	36	37	14.2	0.48	14.68	33.01	18.33	Complied
2562.5	36	0	14.4	0.48	14.88	33.01	18.13	Complied
2562.5	36	18	14.4	0.48	14.88	33.01	18.13	Complied
2562.5	1	74	15.6	0.48	16.08	33.01	16.93	Complied
2562.5	1	0	16.1	0.48	16.58	33.01	16.43	Complied
2562.5	1	36	15.8	0.48	16.28	33.01	16.73	Complied

**Transmitter Output Power (EIRP) (continued)****Results: 20 MHz Channel Bandwidth / Bottom Channel / QPSK**

Frequency (MHz)	Resource Block(s)	Resource Block Offset	Conducted RF Power (dBm)	Antenna Gain (dBi)	EIRP (dBm)	EIRP Limit (dBm)	Margin (dB)	Result
2510.0	100	0	15.8	0.48	16.28	33.01	16.73	Complied
2510.0	50	49	16.3	0.48	16.78	33.01	16.23	Complied
2510.0	50	0	15.3	0.48	15.78	33.01	17.23	Complied
2510.0	50	24	15.6	0.48	16.08	33.01	16.93	Complied
2510.0	1	99	16.9	0.48	17.38	33.01	15.63	Complied
2510.0	1	0	16.6	0.48	17.08	33.01	15.93	Complied
2510.0	1	49	16.9	0.48	17.38	33.01	15.63	Complied

**Results: 20 MHz Channel Bandwidth / Bottom Channel / 16QAM**

Frequency (MHz)	Resource Block(s)	Resource Block Offset	Conducted RF Power (dBm)	Antenna Gain (dBi)	EIRP (dBm)	EIRP Limit (dBm)	Margin (dB)	Result
2510.0	100	0	15.0	0.48	15.48	33.01	17.53	Complied
2510.0	50	49	15.6	0.48	16.08	33.01	16.93	Complied
2510.0	50	0	14.6	0.48	15.08	33.01	17.93	Complied
2510.0	50	24	14.9	0.48	15.38	33.01	17.63	Complied
2510.0	1	99	15.9	0.48	16.38	33.01	16.63	Complied
2510.0	1	0	15.5	0.48	15.98	33.01	17.03	Complied
2510.0	1	49	16.0	0.48	16.48	33.01	16.53	Complied

**Results: 20 MHz Channel Bandwidth / Middle Channel / QPSK**

Frequency (MHz)	Resource Block(s)	Resource Block Offset	Conducted RF Power (dBm)	Antenna Gain (dBi)	EIRP (dBm)	EIRP Limit (dBm)	Margin (dB)	Result
2535.0	100	0	15.5	0.48	15.98	33.01	17.03	Complied
2535.0	50	49	15.8	0.48	16.28	33.01	16.73	Complied
2535.0	50	0	15.5	0.48	15.98	33.01	17.03	Complied
2535.0	50	24	15.4	0.48	15.88	33.01	17.13	Complied
2535.0	1	99	16.6	0.48	17.08	33.01	15.93	Complied
2535.0	1	0	17.2	0.48	17.68	33.01	15.33	Complied
2535.0	1	49	16.6	0.48	17.08	33.01	15.93	Complied

**Transmitter Output Power (EIRP) (continued)****Results: 20 MHz Channel Bandwidth / Middle Channel / 16QAM**

Frequency (MHz)	Resource Block(s)	Resource Block Offset	Conducted RF Power (dBm)	Antenna Gain (dBi)	EIRP (dBm)	EIRP Limit (dBm)	Margin (dB)	Result
2535.0	100	0	15.1	0.48	15.58	33.01	17.43	Complied
2535.0	50	49	15.4	0.48	15.88	33.01	17.13	Complied
2535.0	50	0	14.9	0.48	15.38	33.01	17.63	Complied
2535.0	50	24	14.9	0.48	15.38	33.01	17.63	Complied
2535.0	1	99	15.9	0.48	16.38	33.01	16.63	Complied
2535.0	1	0	16.5	0.48	16.98	33.01	16.03	Complied
2535.0	1	49	16.0	0.48	16.48	33.01	16.53	Complied

**Results: 20 MHz Channel Bandwidth / Top Channel / QPSK**

Frequency (MHz)	Resource Block(s)	Resource Block Offset	Conducted RF Power (dBm)	Antenna Gain (dBi)	EIRP (dBm)	EIRP Limit (dBm)	Margin (dB)	Result
2560.0	100	0	15.3	0.48	15.78	33.01	17.23	Complied
2560.0	50	49	15.3	0.48	15.78	33.01	17.23	Complied
2560.0	50	0	15.4	0.48	15.88	33.01	17.13	Complied
2560.0	50	24	15.3	0.48	15.78	33.01	17.23	Complied
2560.0	1	99	16.5	0.48	16.98	33.01	16.03	Complied
2560.0	1	0	17.0	0.48	17.48	33.01	15.53	Complied
2560.0	1	49	16.5	0.48	16.98	33.01	16.03	Complied

**Results: 20 MHz Channel Bandwidth / Top Channel / 16QAM**

Frequency (MHz)	Resource Block(s)	Resource Block Offset	Conducted RF Power (dBm)	Antenna Gain (dBi)	EIRP (dBm)	EIRP Limit (dBm)	Margin (dB)	Result
2560.0	100	0	14.5	0.48	14.98	33.01	18.03	Complied
2560.0	50	49	14.5	0.48	14.98	33.01	18.03	Complied
2560.0	50	0	14.6	0.48	15.08	33.01	17.93	Complied
2560.0	50	24	14.5	0.48	14.98	33.01	18.03	Complied
2560.0	1	99	15.3	0.48	15.78	33.01	17.23	Complied
2560.0	1	0	15.9	0.48	16.38	33.01	16.63	Complied
2560.0	1	49	15.5	0.48	15.98	33.01	17.03	Complied

**Transmitter Output Power (EIRP) (continued)****Test Equipment Used:**

Asset No.	Instrument	Manufacturer	Type No.	Serial No.	Date Calibration Due	Cal. Interval (Months)
M2002	Thermohygrometer	Testo	608-H1	45041825	02 Apr 2017	12
M1869	Wideband Radio Comms Tester	Rohde & Schwarz	CMW500	145923	05 Apr 2017	12
A2845	Attenuator	Radiall	R411.806.121	24325927	Calibrated before use	-
A2844	Attenuator	Radiall	R411.803.121	23404066	Calibrated before use	-
S0562	Power Supply	Thurlby Thandar	PL330QMD	054895	Calibrated before use	-
M1269	Multimeter	Fluke	179	90250210	13 May 2017	12
G0628	Signal Generator	Rohde & Schwarz	SMBV100A	261847	25 Jan 2017	12
M1835	Signal Analyser	Rohde & Schwarz	FSV30	103050	26 Feb 2017	12

**5.2.3. Transmitter Peak-To-Average Ratio (PAR)**

**Test Summary:**

<b>Test Engineer:</b>	Keith Tucker	<b>Test Date:</b>	18 July 2016
<b>Test Sample IMEI:</b>	358640070066221		

<b>FCC Reference:</b>	Part 27.50(d)(5)
<b>Test Method Used:</b>	KDB 971168 Section 5.7.1

**Environmental Conditions:**

<b>Temperature (°C):</b>	23
<b>Relative Humidity (%):</b>	53

**Note(s):**

1. The CCDF analyser function of a communications test set was used to measure PAPR when the EUT was transmitting with both QPSK and 16QAM modulations, all supported channel bandwidths on bottom, middle and top channels for 1 resource block. Maximum PAPR levels associated with a probability of 0.1% were recorded.

**Test setup:**

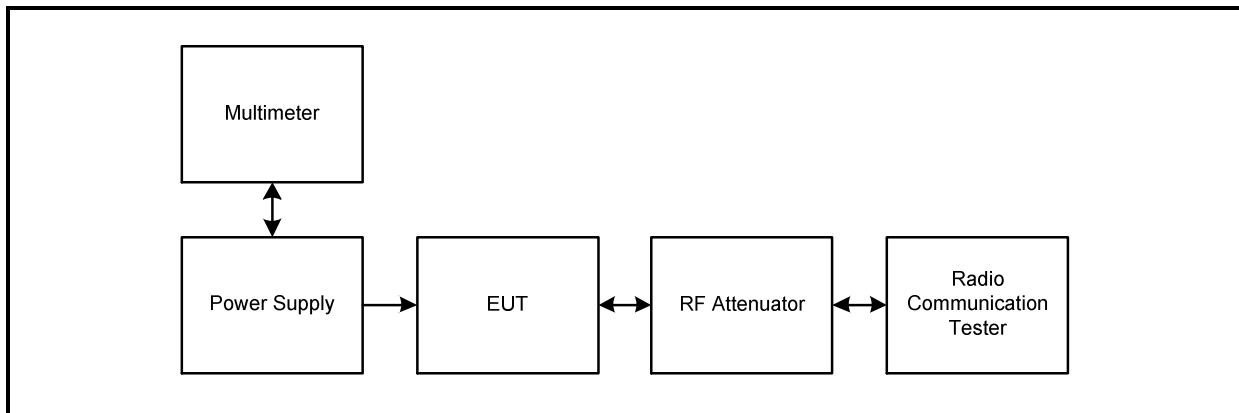

**Transmitter Peak-To-Average Ratio (PAR) (continued)**

**Results: 5 MHz Channel Bandwidth / QPSK**

Channel	Resource Block(s)	Resource Block Offset	PAR (dB)	Ratio Limit (dB)	Margin (dB)	Result
Bottom	1	0	3.7	13.0	9.3	Complied
Middle	1	0	4.5	13.0	8.5	Complied
Top	1	0	3.6	13.0	9.4	Complied

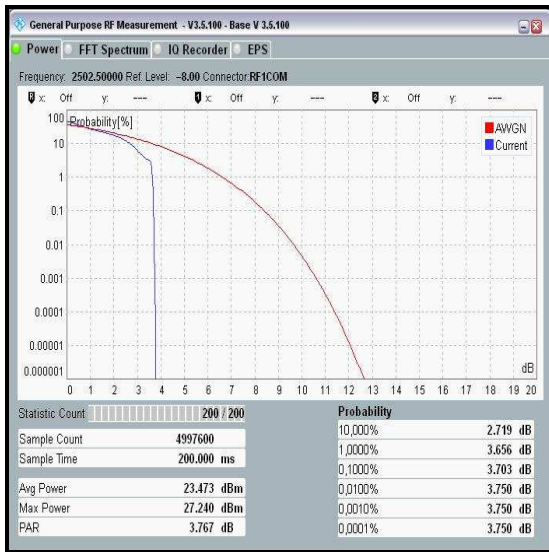

**Bottom Channel / QPSK**

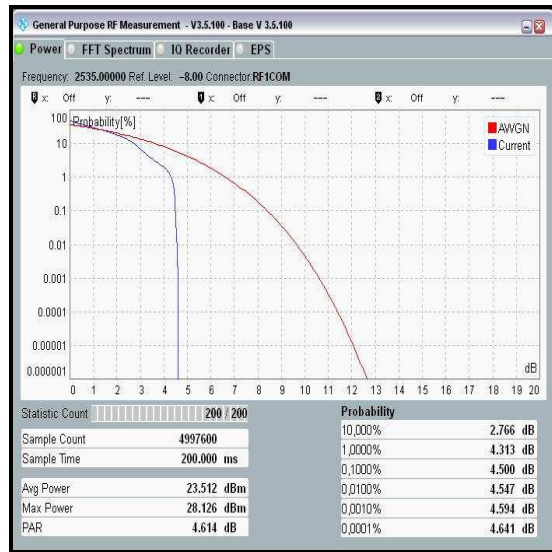

**Middle Channel / QPSK**

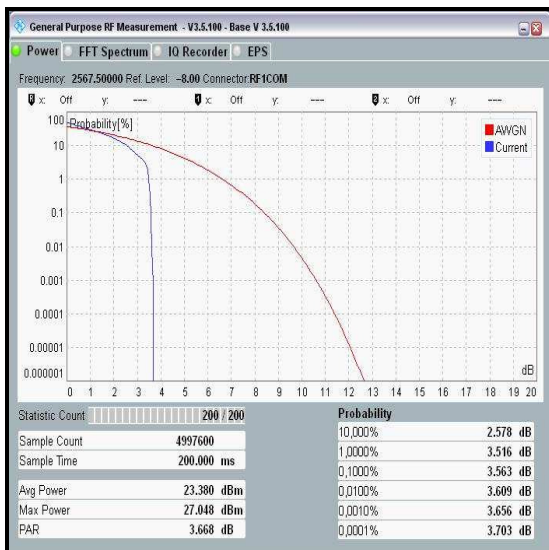

**Top Channel / QPSK**

**Transmitter Peak-To-Average Ratio (PAR) (continued)**

**Results: 5 MHz Channel Bandwidth / 16QAM**

Channel	Resource Block(s)	Resource Block Offset	PAR (dB)	Ratio Limit (dB)	Margin (dB)	Result
Bottom	1	0	5.3	13.0	7.7	Complied
Middle	1	0	4.8	13.0	8.2	Complied
Top	1	0	5.8	13.0	7.2	Complied

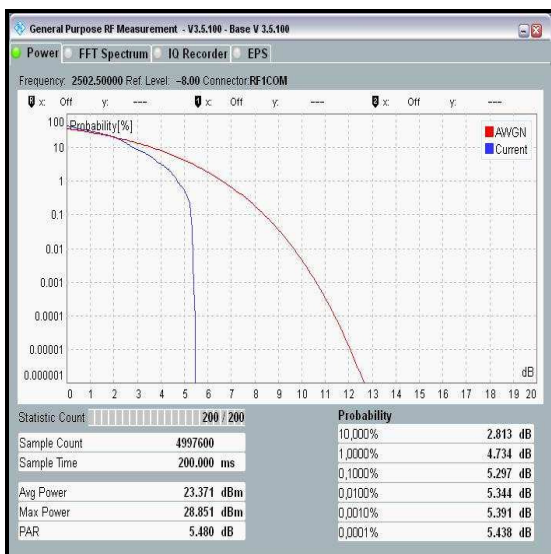

**Bottom Channel / 16QAM**

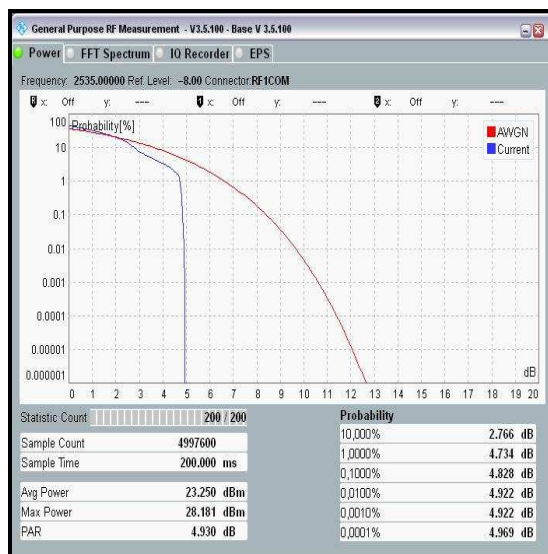

**Middle Channel / 16QAM**

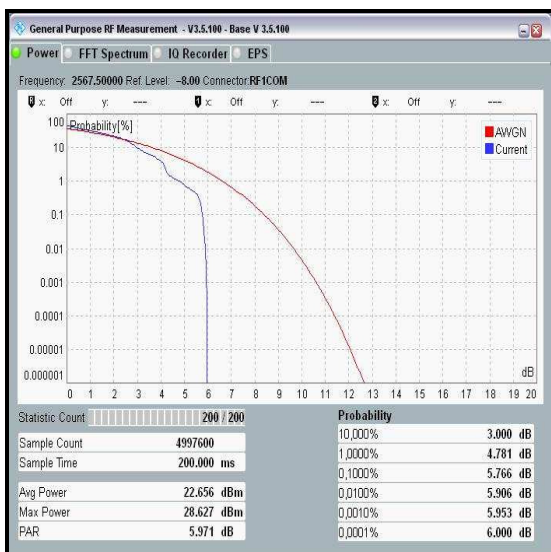

**Top Channel / 16QAM**

**Transmitter Peak-To-Average Ratio (PAR) (continued)**

**Results: 10 MHz Channel Bandwidth / QPSK**

Channel	Resource Block(s)	Resource Block Offset	PAR (dB)	Ratio Limit (dB)	Margin (dB)	Result
Bottom	1	0	3.7	13.0	9.3	Complied
Middle	1	0	4.6	13.0	8.4	Complied
Top	1	0	4.2	13.0	8.8	Complied

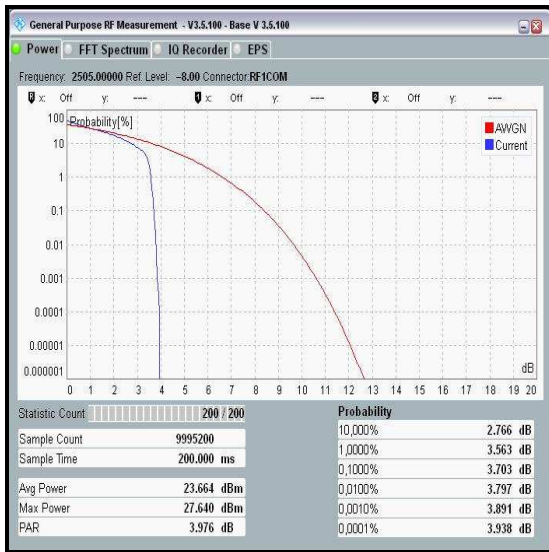

**Bottom Channel / QPSK**

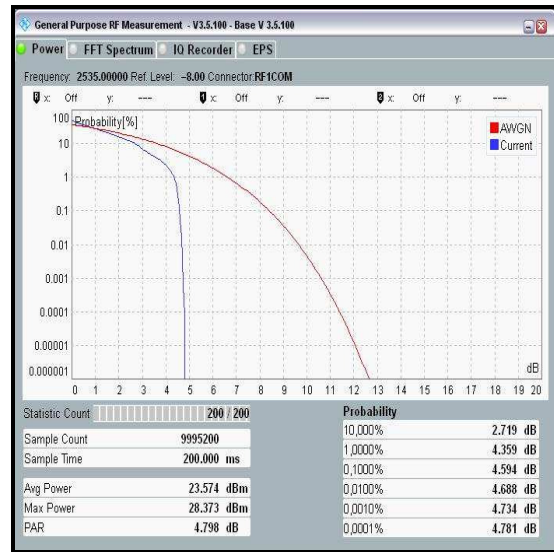

**Middle Channel / QPSK**

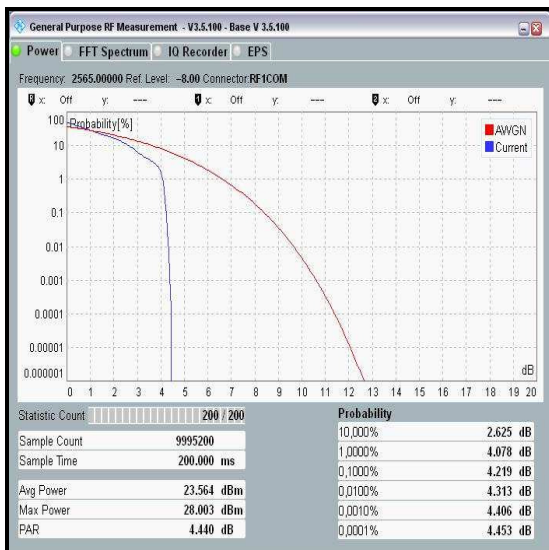

**Top Channel / QPSK**

**Transmitter Peak-To-Average Ratio (PAR) (continued)**

**Results: 10 MHz Channel Bandwidth / 16QAM**

Channel	Resource Block(s)	Resource Block Offset	PAR (dB)	Ratio Limit (dB)	Margin (dB)	Result
Bottom	1	0	5.1	13.0	7.9	Complied
Middle	1	0	5.2	13.0	7.8	Complied
Top	1	0	4.2	13.0	8.8	Complied

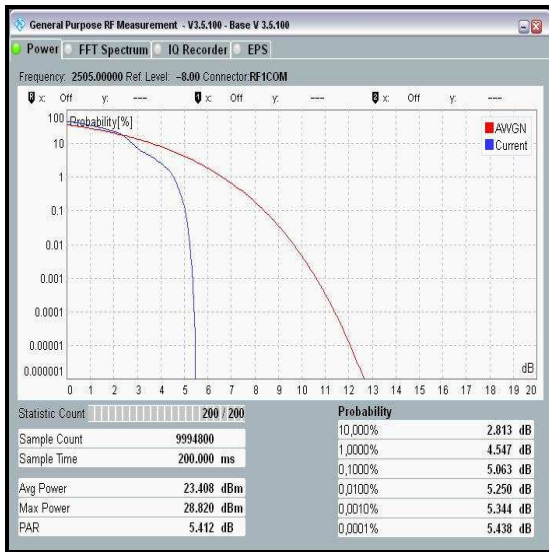

**Bottom Channel / 16QAM**

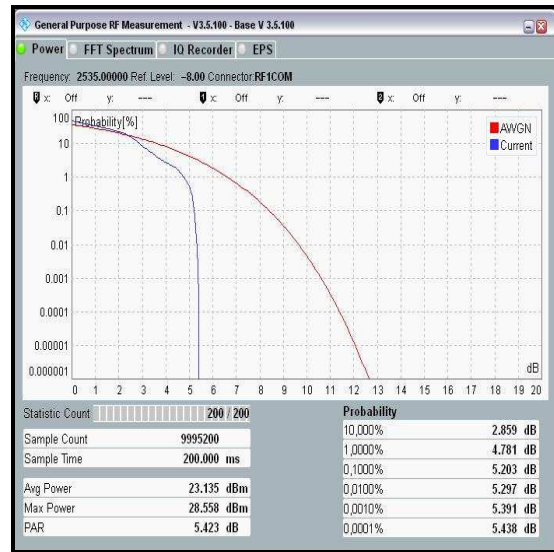

**Middle Channel / 16QAM**

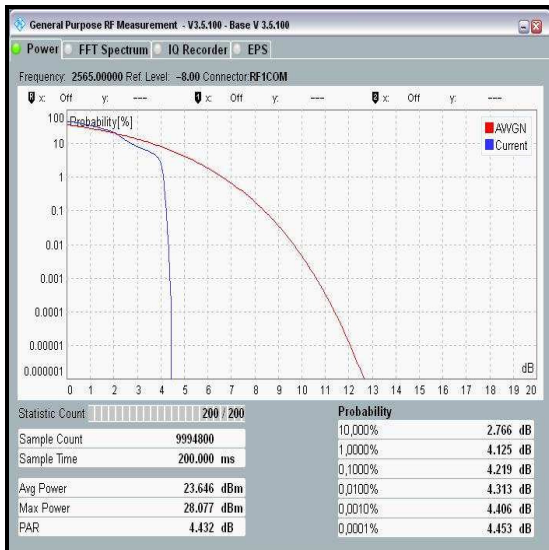

**Top Channel / 16QAM**

**Transmitter Peak-To-Average Ratio (PAR) (continued)**

**Results: 15 MHz Channel Bandwidth / QPSK**

Channel	Resource Block(s)	Resource Block Offset	PAR (dB)	Ratio Limit (dB)	Margin (dB)	Result
Bottom	1	0	3.9	13.0	9.1	Complied
Middle	1	0	4.6	13.0	8.4	Complied
Top	1	0	4.7	13.0	8.3	Complied

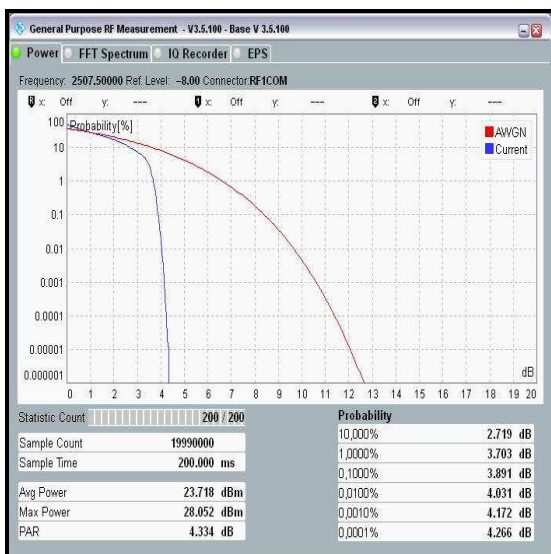

**Bottom Channel / QPSK**

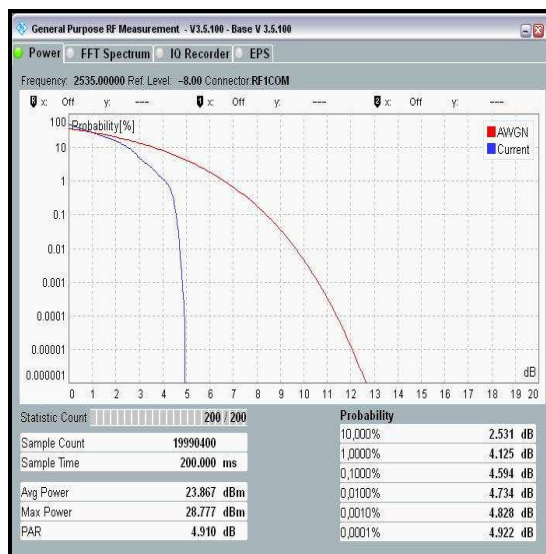

**Middle Channel / QPSK**

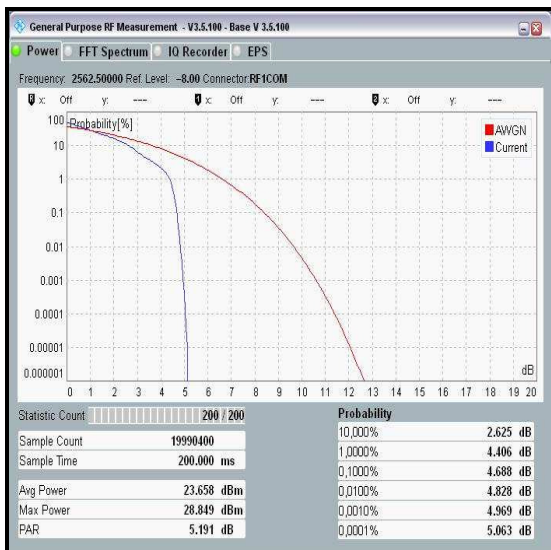

**Top Channel / QPSK**

**Transmitter Peak-To-Average Ratio (PAR) (continued)**

**Results: 15 MHz Channel Bandwidth / 16QAM**

Channel	Resource Block(s)	Resource Block Offset	PAR (dB)	Ratio Limit (dB)	Margin (dB)	Result
Bottom	1	0	5.1	13.0	7.9	Complied
Middle	1	0	5.0	13.0	8.0	Complied
Top	1	0	4.7	13.0	8.3	Complied

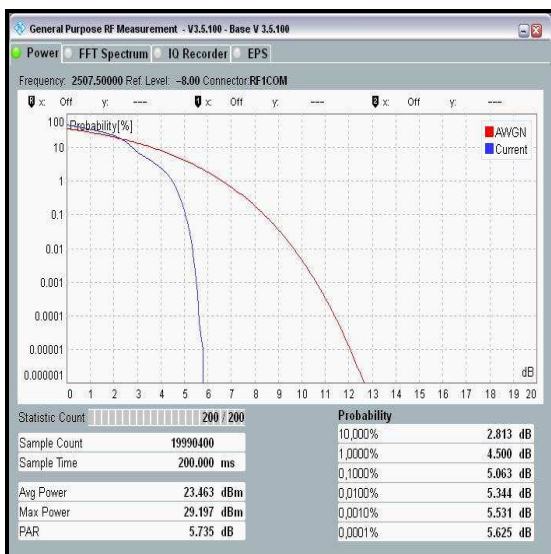

**Bottom Channel / 16QAM**

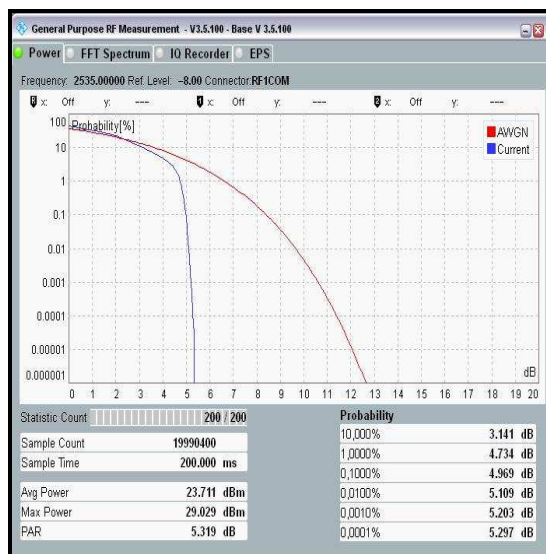

**Middle Channel / 16QAM**

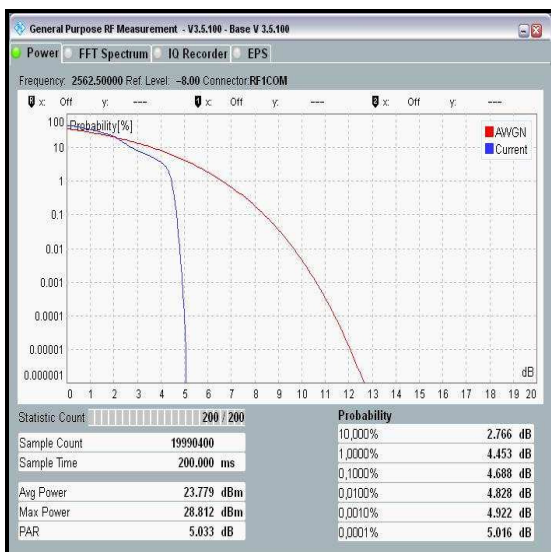

**Top Channel / 16QAM**

**Transmitter Peak-To-Average Ratio (PAR) (continued)**

**Results: 20 MHz Channel Bandwidth / QPSK**

Channel	Resource Block(s)	Resource Block Offset	PAR (dB)	Ratio Limit (dB)	Margin (dB)	Result
Bottom	1	0	4.7	13.0	8.3	Complied
Middle	1	0	4.6	13.0	8.4	Complied
Top	1	0	4.2	13.0	8.8	Complied

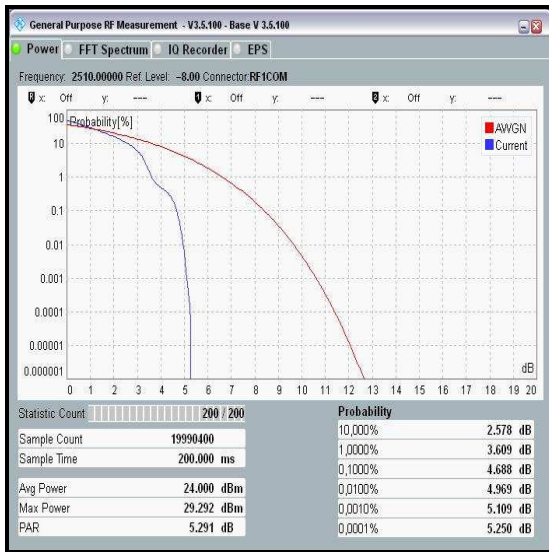

**Bottom Channel / QPSK**

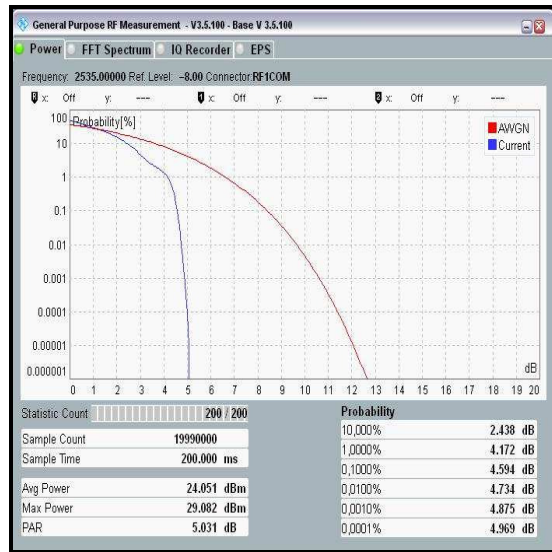

**Middle Channel / QPSK**

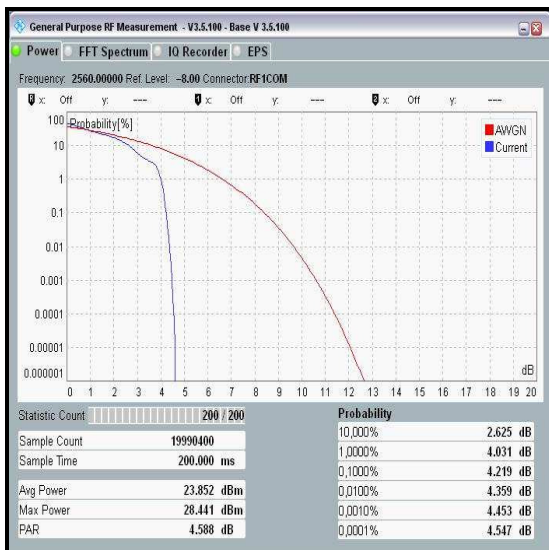

**Top Channel / QPSK**

**Transmitter Peak-To-Average Ratio (PAR) (continued)**

**Results: 20 MHz Channel Bandwidth / 16QAM**

Channel	Resource Block(s)	Resource Block Offset	PAR (dB)	Ratio Limit (dB)	Margin (dB)	Result
Bottom	1	0	5.4	13.0	7.6	Complied
Middle	1	0	4.7	13.0	8.3	Complied
Top	1	0	4.4	13.0	8.6	Complied

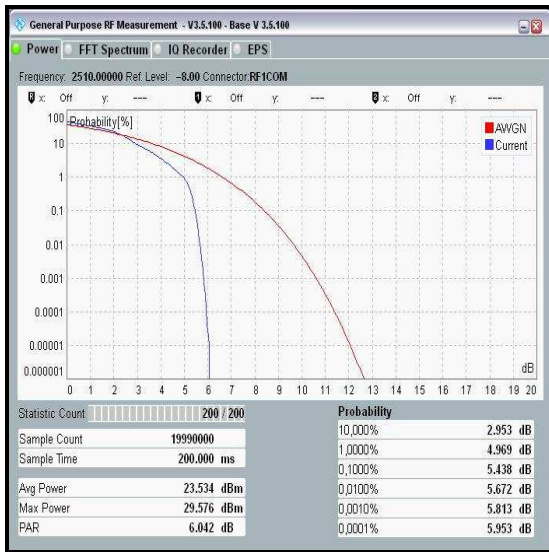

**Bottom Channel / 16QAM**

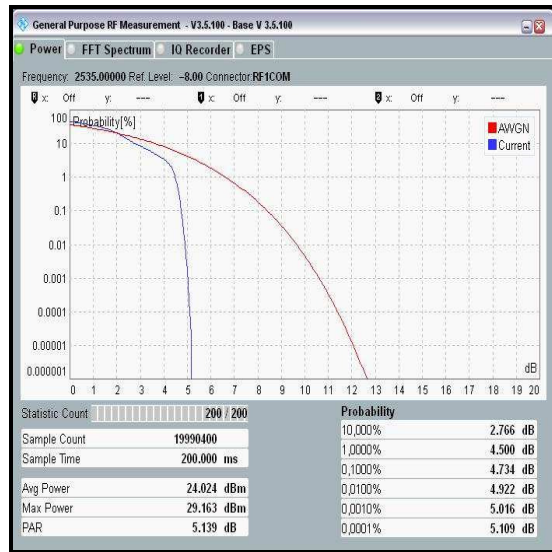

**Middle Channel / 16QAM**

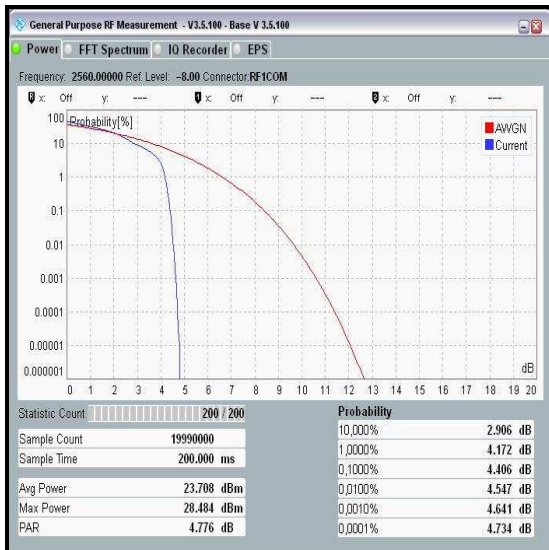

**Top Channel / 16QAM**

**Transmitter Peak-To-Average Ratio (PAR) (continued)****Test Equipment Used:**

<b>Asset No.</b>	<b>Instrument</b>	<b>Manufacturer</b>	<b>Type No.</b>	<b>Serial No.</b>	<b>Date Calibration Due</b>	<b>Cal. Interval (Months)</b>
M2002	Thermohygrometer	Testo	608-H1	45041825	02 Apr 2017	12
M1869	Wideband Radio Comms Tester	Rohde & Schwarz	CMW500	145923	05 Apr 2017	12
A2845	Attenuator	Radiall	R411.806.121	24325927	Calibrated before use	-
A2844	Attenuator	Radiall	R411.803.121	23404066	Calibrated before use	-
S0562	Power Supply	Thurlby Thandar	PL330QMD	054895	Calibrated before use	-
M1269	Multimeter	Fluke	179	90250210	13 May 2017	12
G0628	Signal Generator	Rohde & Schwarz	SMBV100A	261847	25 Jan 2017	12
M1835	Signal Analyser	Rohde & Schwarz	FSV30	103050	26 Feb 2017	12

**5.2.4. Transmitter Occupied Bandwidth**

**Test Summary:**

<b>Test Engineer:</b>	Keith Tucker	<b>Test Date:</b>	22 June 2016
<b>Test Sample IMEI:</b>	358640070064218		

<b>FCC Reference:</b>	Part 2.1049
<b>Test Method Used:</b>	KDB 971168 Section 4.2

**Environmental Conditions:**

<b>Temperature (°C):</b>	24
<b>Relative Humidity (%):</b>	56

**Note(s):**

1. Occupied bandwidth (99% bandwidth) was measured using a signal analyser occupied bandwidth function.
2. Measurements were performed with the EUT transmitting with QPSK and 16QAM modulation schemes, with resource blocks settings as detailed in section 4.3 of this report.
3. The RF port of the EUT was connected to the signal analyser via RF cables, directional coupler and suitable attenuation.

**Test setup:**

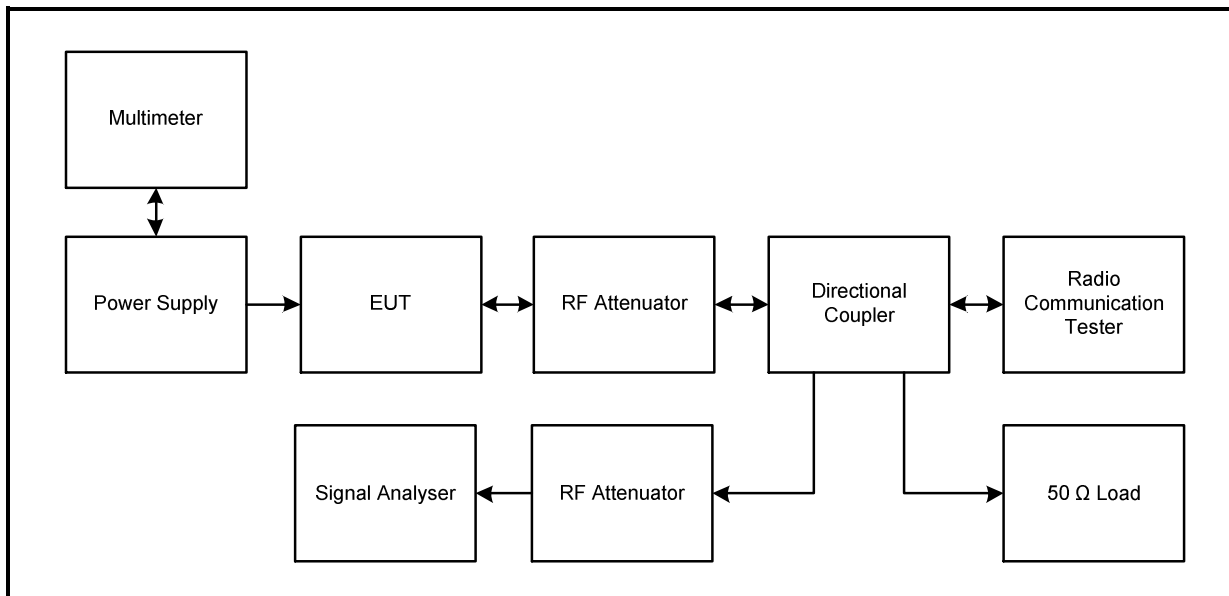

**Transmitter Occupied Bandwidth (continued)**

**Results: 5 MHz Channel Bandwidth / QPSK**

Channel	Resource Block(s)	Resource Block Offset	Resolution Bandwidth (kHz)	Video Bandwidth (kHz)	Occupied Bandwidth (MHz)
Bottom	25	0	100	300	4.510
Middle	25	0	100	300	4.526
Top	25	0	100	300	4.510

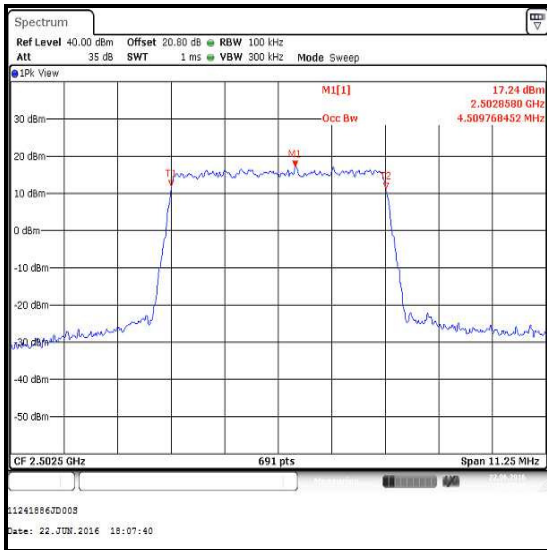

**Bottom Channel / QPSK**

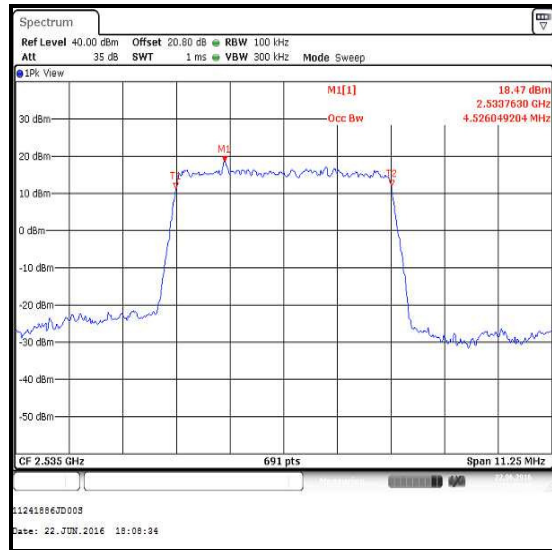

**Middle Channel / QPSK**

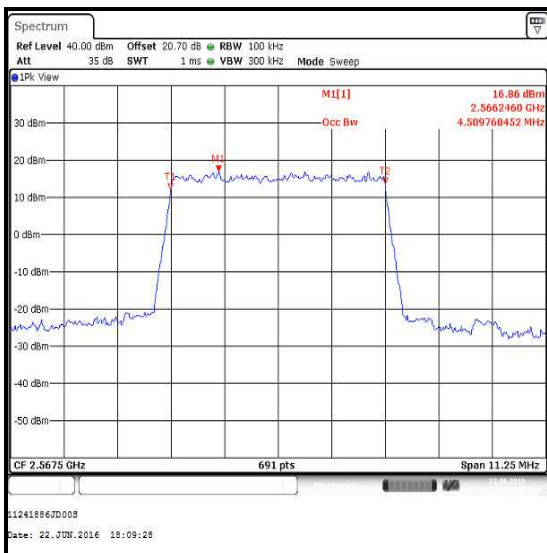

**Top Channel / QPSK**

**Transmitter Occupied Bandwidth (continued)**

**Results: 5 MHz Channel Bandwidth / 16QAM**

Channel	Resource Block(s)	Resource Block Offset	Resolution Bandwidth (kHz)	Video Bandwidth (kHz)	Occupied Bandwidth (MHz)
Bottom	25	0	100	300	4.510
Middle	25	0	100	300	4.526
Top	25	0	100	300	4.493

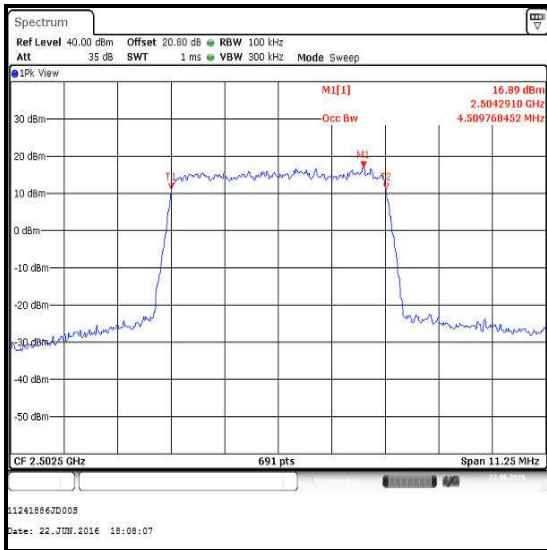

**Bottom Channel / 16QAM**



**Middle Channel / 16QAM**

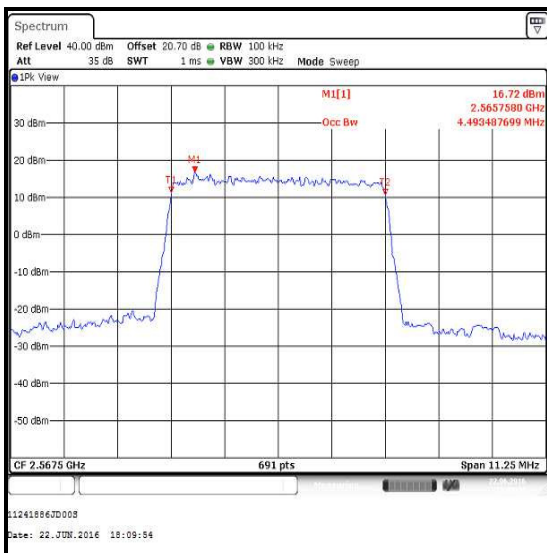

**Top Channel / 16QAM**

**Transmitter Occupied Bandwidth (continued)**

**Results: 10 MHz Channel Bandwidth / QPSK**

Channel	Resource Block(s)	Resource Block Offset	Resolution Bandwidth (kHz)	Video Bandwidth (kHz)	Occupied Bandwidth (MHz)
Bottom	50	0	200	1000	8.987
Middle	50	0	200	1000	9.020
Top	50	0	200	1000	8.987

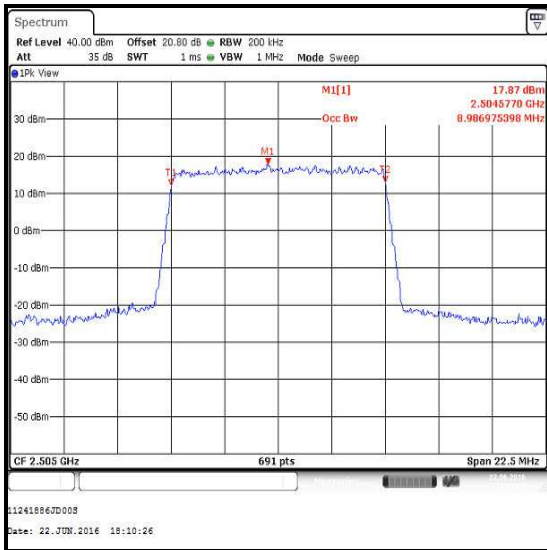

**Bottom Channel / QPSK**



**Middle Channel / QPSK**

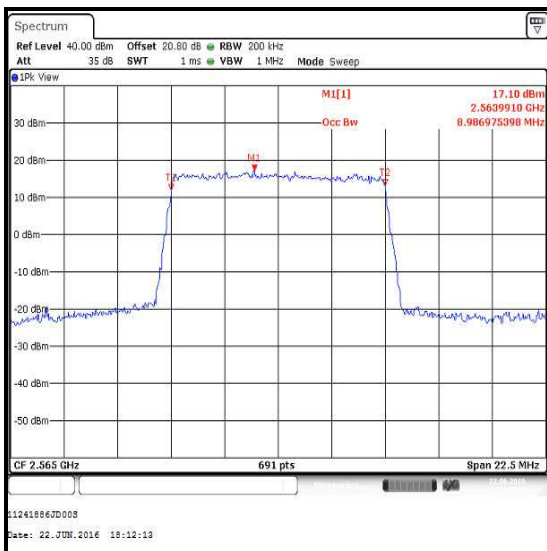

**Top Channel / QPSK**

**Transmitter Occupied Bandwidth (continued)**

**Results: 10 MHz Channel Bandwidth / 16QAM**

Channel	Resource Block(s)	Resource Block Offset	Resolution Bandwidth (kHz)	Video Bandwidth (kHz)	Occupied Bandwidth (MHz)
Bottom	50	0	200	1000	8.987
Middle	50	0	200	1000	8.987
Top	50	0	200	1000	9.020

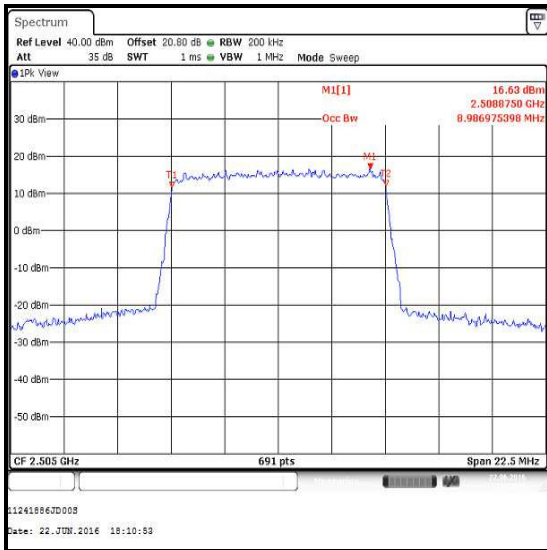

**Bottom Channel / 16QAM**



**Middle Channel / 16QAM**

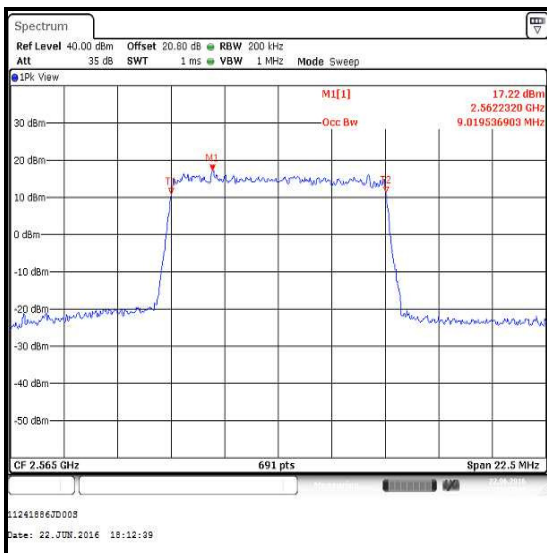

**Top Channel / 16QAM**

**Transmitter Occupied Bandwidth (continued)**

**Results: 15 MHz Channel Bandwidth / QPSK**

Channel	Resource Block(s)	Resource Block Offset	Resolution Bandwidth (kHz)	Video Bandwidth (kHz)	Occupied Bandwidth (MHz)
Bottom	75	0	300	1000	13.480
Middle	75	0	300	1000	13.480
Top	75	0	300	1000	13.480

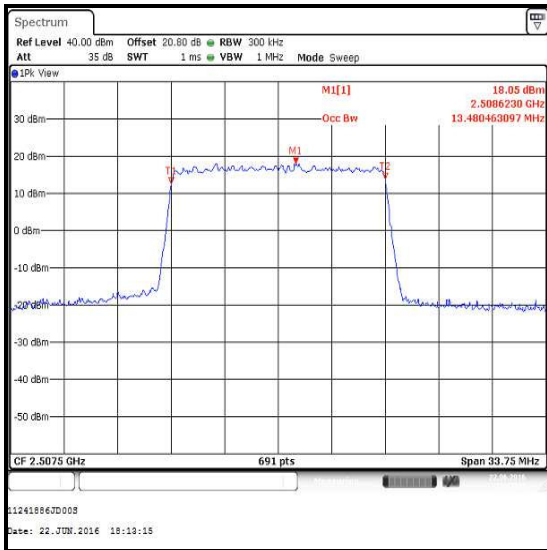

**Bottom Channel / QPSK**

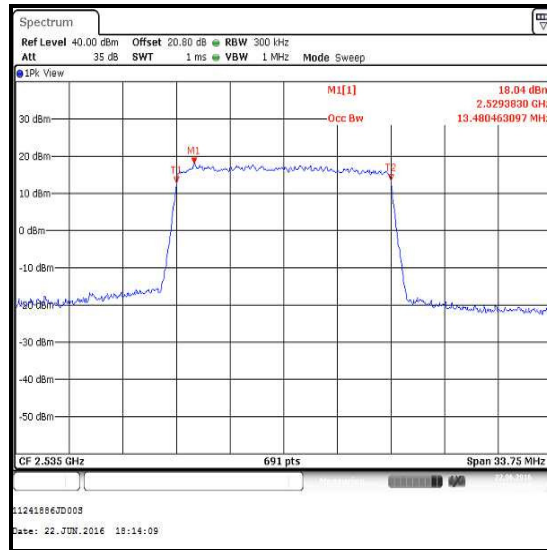

**Middle Channel / QPSK**

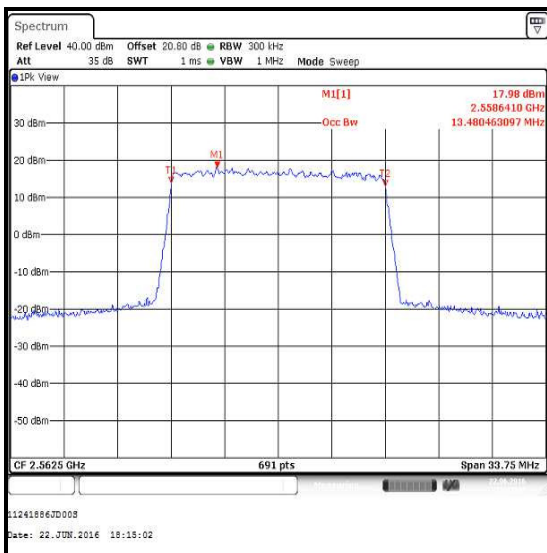

**Top Channel / QPSK**

**Transmitter Occupied Bandwidth (continued)**

**Results: 15 MHz Channel Bandwidth / 16QAM**

Channel	Resource Block(s)	Resource Block Offset	Resolution Bandwidth (kHz)	Video Bandwidth (kHz)	Occupied Bandwidth (MHz)
Bottom	75	0	300	1000	13.432
Middle	75	0	300	1000	13.480
Top	75	0	300	1000	13.529

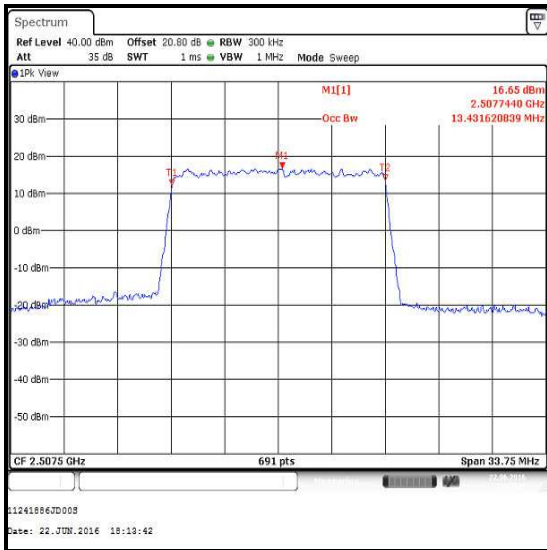

**Bottom Channel / 16QAM**



**Middle Channel / 16QAM**



**Top Channel / 16QAM**

**Transmitter Occupied Bandwidth (continued)**

**Results: 20 MHz Channel Bandwidth / QPSK**

Channel	Resource Block(s)	Resource Block Offset	Resolution Bandwidth (kHz)	Video Bandwidth (kHz)	Occupied Bandwidth (MHz)
Bottom	100	0	500	2000	18.104
Middle	100	0	500	2000	17.974
Top	100	0	500	2000	18.039

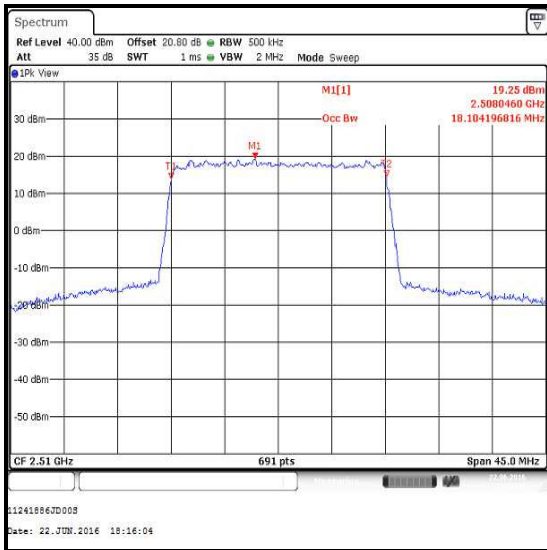

**Bottom Channel / QPSK**

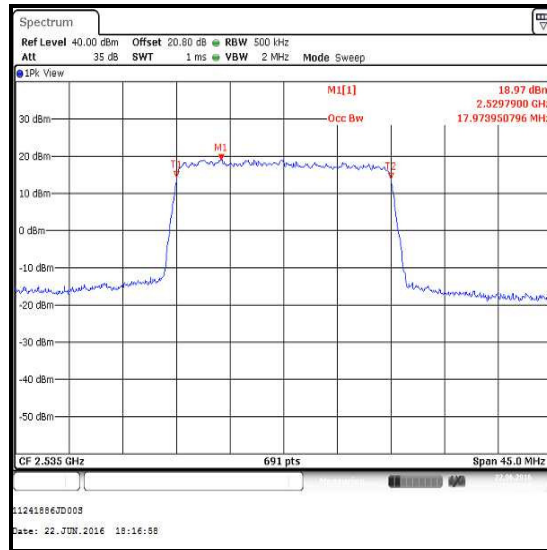

**Middle Channel / QPSK**



**Top Channel / QPSK**

**Transmitter Occupied Bandwidth (continued)**

**Results: 20 MHz Channel Bandwidth / 16QAM**

Channel	Resource Block(s)	Resource Block Offset	Resolution Bandwidth (kHz)	Video Bandwidth (kHz)	Occupied Bandwidth (MHz)
Bottom	100	0	500	2000	17.974
Middle	100	0	500	2000	17.974
Top	100	0	500	2000	17.974

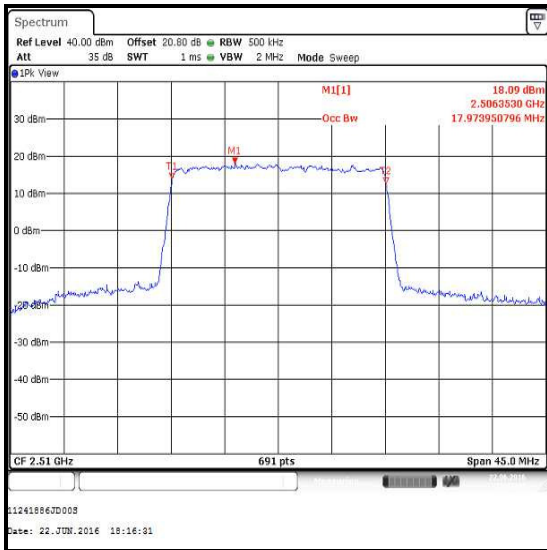

**Bottom Channel / 16QAM**



**Middle Channel / 16QAM**

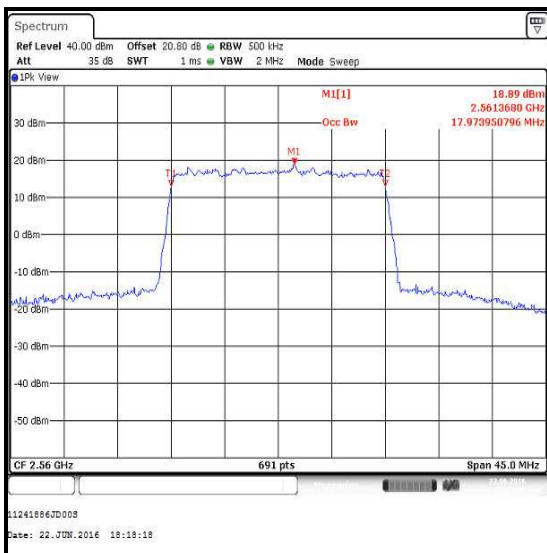

**Top Channel / 16QAM**

**Transmitter Occupied Bandwidth (continued)****Test Equipment Used:**

<b>Asset No.</b>	<b>Instrument</b>	<b>Manufacturer</b>	<b>Type No.</b>	<b>Serial No.</b>	<b>Date Calibration Due</b>	<b>Cal. Interval (Months)</b>
M2002	Thermohygrometer	Testo	608-H1	45041825	02 Apr 2017	12
M1869	Wideband Radio Comms Tester	Rohde & Schwarz	CMW500	145923	05 Apr 2017	12
M1996	Signal Analyser	Rohde & Schwarz	FSV13	100975	02 Mar 2017	12
A2845	Attenuator	Radiall	R411.806.121	24325927	Calibrated before use	-
A2844	Attenuator	Radiall	R411.803.121	23404066	Calibrated before use	-
A2504	Directional Coupler	AtlanTecRF	CDC-003060-10	13122501839	Calibrated before use	-
S0562	Power Supply	Thurby Thandar	PL330QMD	054895	Calibrated before use	-
M1269	Multimeter	Fluke	179	90250210	13 May 2017	12
G0628	Signal Generator	Rohde & Schwarz	SMBV100A	261847	25 Jan 2017	12
M1835	Signal Analyser	Rohde & Schwarz	FSV30	103050	26 Feb 2017	12

**5.2.5. Transmitter Radiated Spurious Emissions - LAT****Test Summary:**

<b>Test Engineers:</b>	David Doyle & Andrew Edwards	<b>Test Dates:</b>	25 May 2016 to 06 June 2016
<b>Test Sample IMEI:</b>	358640070087480		

<b>FCC Reference:</b>	Parts 2.1053 & 27.53(m)(4)
<b>Test Method Used:</b>	KDB 971168 Section 6.1 referencing FCC Part 2.1053
<b>Frequency Range:</b>	30 MHz to 26 GHz
<b>Configuration:</b>	10 MHz, QPSK, 1RB, 0 Offset

**Environmental Conditions:**

<b>Temperature (°C):</b>	23 to 24
<b>Relative Humidity (%):</b>	38 to 48

**Note(s):**

1. The EUT was set to transmit with a 10 MHz channel bandwidth with QPSK modulation applied and 1 resource block with 0 offset, as this was found to be the worst case modulation scheme with regards to emissions after preliminary investigations and was therefore deemed to be the worst case.
2. The emission seen on the 1 GHz to 3 GHz plot at approximately 2535 MHz is the EUT carrier.
3. No spurious emissions were detected above the measurement system noise floor therefore the highest peak noise floor reading of the measuring receiver was recorded in the table below.
4. Middle channel results are recorded in this report and are representative of bottom and top channel results which are held on the UL IT server and available for inspection on request.
5. Pre-scan measurements below 1 GHz are performed on separate plots with different transducer factors for vertical and horizontal polarisation. The pre-scan plot for 30 MHz to 1 GHz in this test report is for vertical only. All other plots are stored on the company server and are available if required.
6. Measurements below 1 GHz were performed in a semi-anechoic chamber (Asset Number K0017) at a distance of 3 metres. The EUT was placed at a height of 80 cm above the reference ground plane in the centre of the chamber turntable. Maximum emission levels were determined by height searching the measurement antenna over the range 1 metre to 4 metres.
7. Pre-scans above 1 GHz were performed in a semi-anechoic chamber (Asset Number K0017) at a distance of 3 metres. The EUT was placed at a height of 1.5 metres above the test chamber floor in the centre of the chamber turntable. Maximum emission levels were determined by height searching the measurement antenna over the range 1 metre to 4 metres.
8. Radiated spurious emission testing between 150 kHz and 30 MHz was performed for support of the NFC test report. No spurious emissions were observed above the noise floor of the measurement system.
9. Pre-scans have been taken with a limit line set at -13 dBm. In accordance with 27.53(m)(4), the results table has a limit of -25 dBm.

**Transmitter Radiated Spurious Emissions – LAT (continued)**

**Test setup for radiated measurements:**

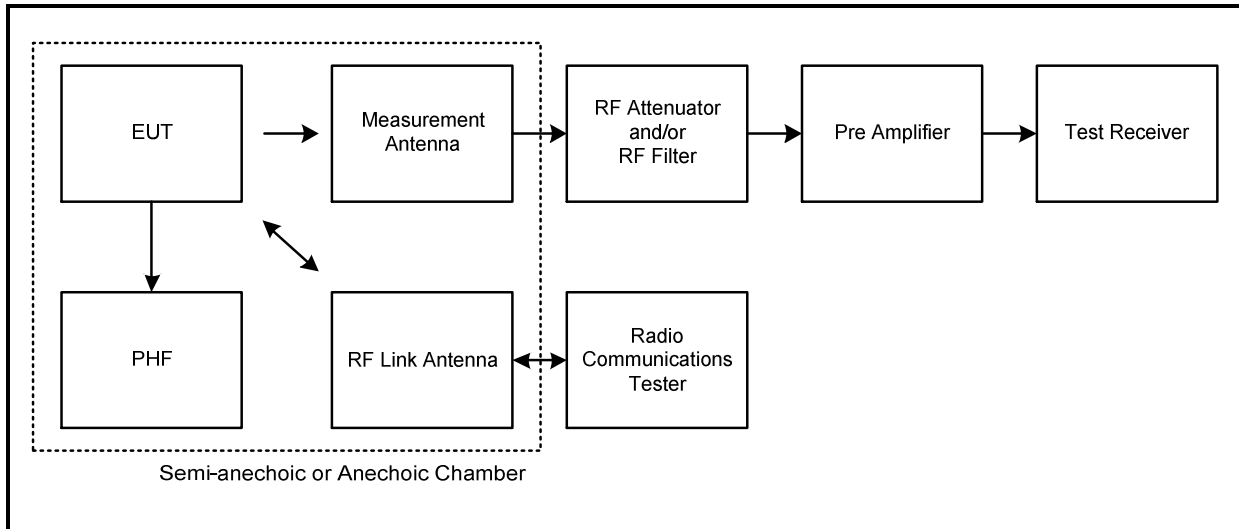

**Results: Middle Channel**

Frequency (MHz)	Peak Level (dBm)	Limit (dBm)	Margin (dB)	Result
1237.179	-31.0	-25.0	6.0	Complied

### Transmitter Radiated Spurious Emissions – LAT (continued)

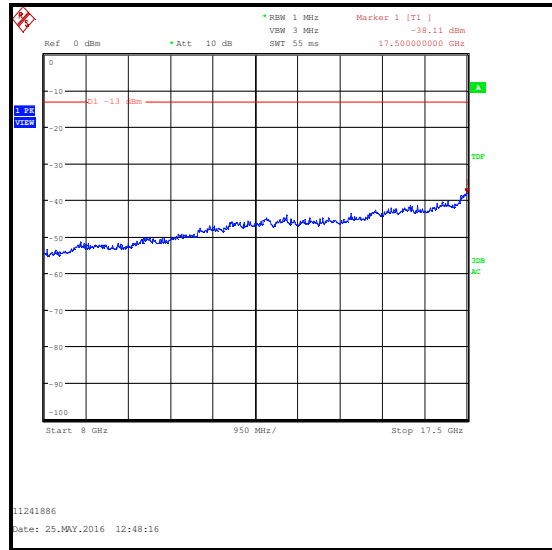
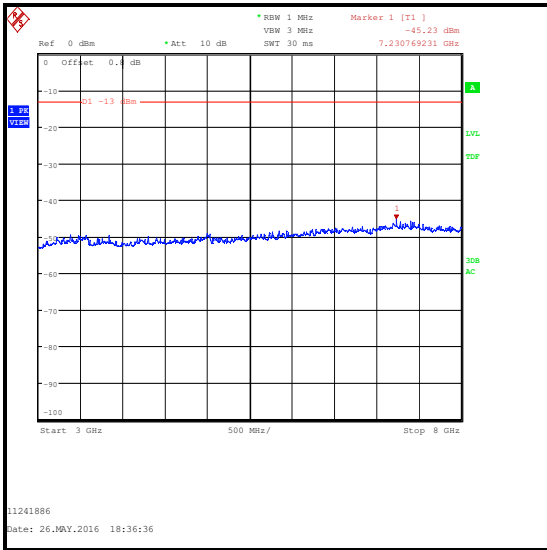
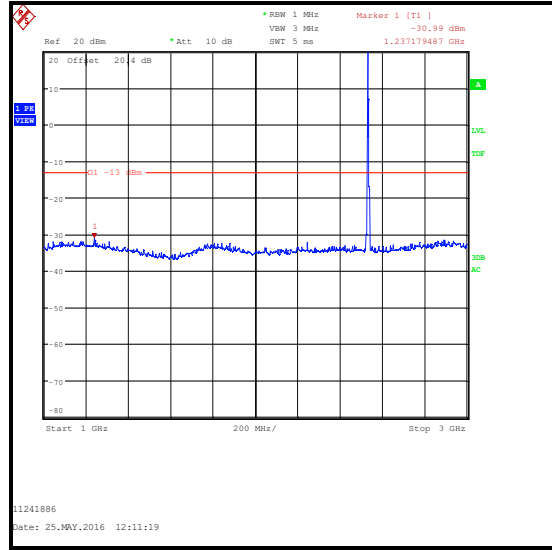
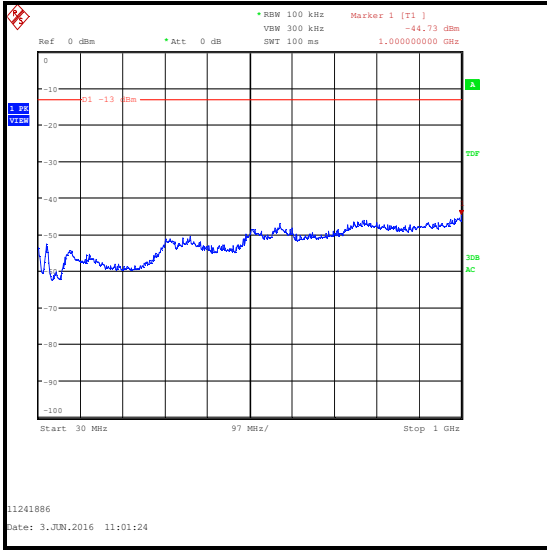

**Transmitter Radiated Spurious Emissions – LAT (continued)**

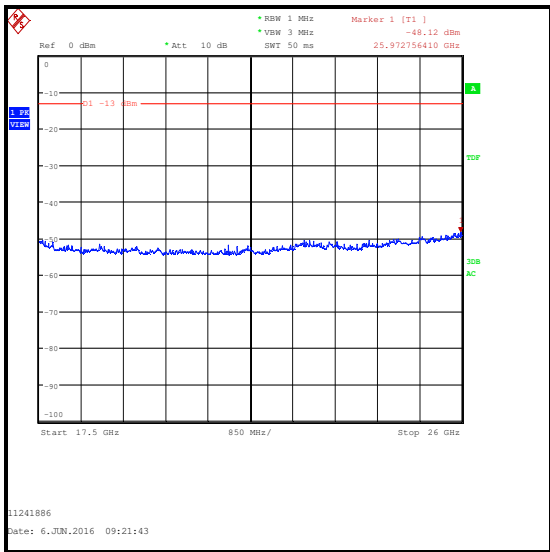

**Test Equipment Used:**

Asset No.	Instrument	Manufacturer	Type No.	Serial No.	Date Calibration Due	Cal. Interval (Months)
M2003	Thermohygrometer	Testo	608-H1	45046641	22 Apr 2017	12
K0017	3m RSE Chamber	Rainford EMC	N/A	N/A	17 May 2017	12
M1995	Test Receiver	Rohde & Schwarz	ESU40	100428	21 Mar 2017	12
A2888	Antenna	Schwarzbeck	VULB 9163	9163-941	07 Apr 2017	12
A2889	Antenna	Schwarzbeck	BBHA 9120 B	BBHA 9120 B	07 Apr 2017	12
A2890	Antenna	Schwarzbeck	HWRD 750	014	06 May 2017	12
A2892	Antenna	Schwarzbeck	BBHA 9170	9170-727	07 Apr 2017	12
A2863	Pre-Amplifier	Agilent	8449B	3008A02100	07 Jan 2017	12
A2891	Pre-Amplifier	Schwarzbeck	BBV 9718	9718-306	07 Apr 2017	12
A2893	Pre-Amplifier	Schwarzbeck	BBV 9721	9721-021	07 Apr 2017	12
S0582	Power Supply	Schwarzbeck	PS9721	00005	Calibrated before use	-
M1818	Multimeter	Fluke	79 Series II	71811580	27 Apr 2017	12
A2914	High Pass Filter	AtlanTecRF	AFH-03000	2155	19 May 2017	12
A2918	Attenuator	AtlanTecRF	AN18W5-20	832828#1	19 May 2017	12

**5.2.6. Transmitter Radiated Spurious Emissions - UAT****Test Summary:**

<b>Test Engineers:</b>	David Doyle & Andrew Edwards	<b>Test Dates:</b>	25 May 2016 to 06 June 2016
<b>Test Sample IMEI:</b>	358640070022890		

<b>FCC Reference:</b>	Parts 2.1053 & 27.53(m)(4)
<b>Test Method Used:</b>	KDB 971168 Section 6.1 referencing FCC Part 2.1053
<b>Frequency Range:</b>	30 MHz to 26 GHz
<b>Configuration:</b>	10 MHz, QPSK, 1RB, 0 Offset

**Environmental Conditions:**

<b>Temperature (°C):</b>	23 to 24
<b>Relative Humidity (%):</b>	38 to 48

**Note(s):**

1. The EUT was set to transmit with a 10 MHz channel bandwidth with QPSK modulation applied and 1 resource block with 0 offset, as this was found to be the worst case modulation scheme with regards to emissions after preliminary investigations and was therefore deemed to be the worst case.
2. The emission seen on the 1 GHz to 3 GHz plot at approximately 2535 MHz is the EUT carrier.
3. No spurious emissions were detected above the measurement system noise floor therefore the highest peak noise floor reading of the measuring receiver was recorded in the table below.
4. Middle channel results are recorded in this report and are representative of bottom and top channel results which are held on the UL IT server and available for inspection on request.
5. Pre-scan measurements below 1 GHz are performed on separate plots with different transducer factors for vertical and horizontal polarisation. The pre-scan plot for 30 MHz to 1 GHz in this test report is for vertical only. All other plots are stored on the company server and are available if required.
6. Measurements below 1 GHz were performed in a semi-anechoic chamber (Asset Number K0017) at a distance of 3 metres. The EUT was placed at a height of 80 cm above the reference ground plane in the centre of the chamber turntable. Maximum emission levels were determined by height searching the measurement antenna over the range 1 metre to 4 metres.
7. Pre-scans above 1 GHz were performed in a semi-anechoic chamber (Asset Number K0017) at a distance of 3 metres. The EUT was placed at a height of 1.5 metres above the test chamber floor in the centre of the chamber turntable. Maximum emission levels were determined by height searching the measurement antenna over the range 1 metre to 4 metres.
8. Radiated spurious emission testing between 150 kHz and 30 MHz was performed for support of the NFC test report. No spurious emissions were observed above the noise floor of the measurement system.
9. Pre-scans have been taken with a limit line set at -13 dBm. In accordance with 27.53(m)(4), the results table has a limit of -25 dBm.

**Results: Middle Channel**

<b>Frequency (MHz)</b>	<b>Peak Level (dBm)</b>	<b>Limit (dBm)</b>	<b>Margin (dB)</b>	<b>Result</b>
2913.462	-31.1	-25.0	6.1	Complied

**Transmitter Radiated Spurious Emissions – UAT (continued)**

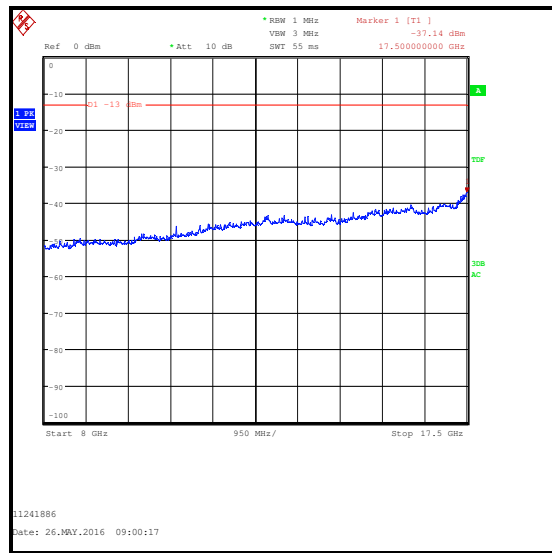
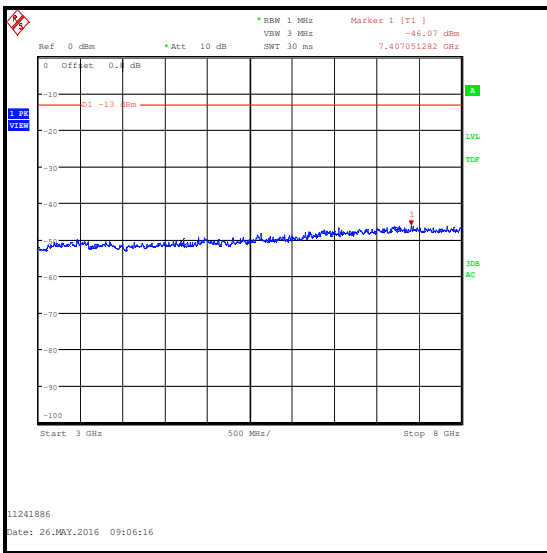
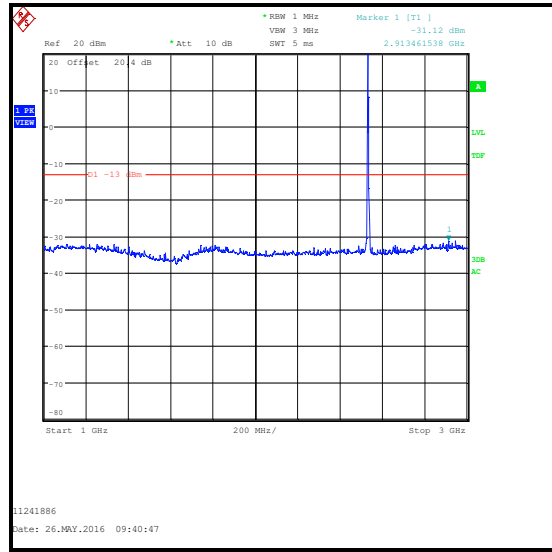
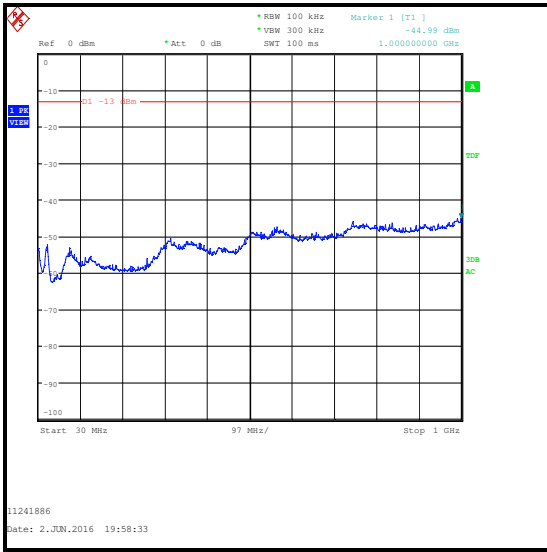

**Transmitter Radiated Spurious Emissions – UAT (continued)**

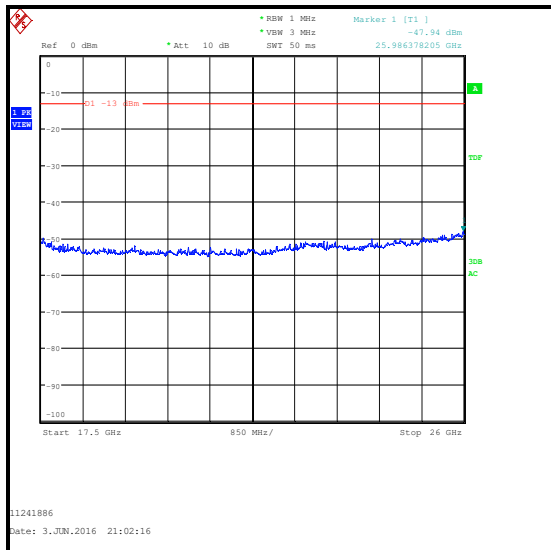

**Test Equipment Used:**

Asset No.	Instrument	Manufacturer	Type No.	Serial No.	Date Calibration Due	Cal. Interval (Months)
M2003	Thermohygrometer	Testo	608-H1	45046641	22 Apr 2017	12
K0017	3m RSE Chamber	Rainford EMC	N/A	N/A	17 May 2017	12
M1995	Test Receiver	Rohde & Schwarz	ESU40	100428	21 Mar 2017	12
A2889	Antenna	Schwarzbeck	BBHA 9120 B	BBHA 9120 B	07 Apr 2017	12
A2890	Antenna	Schwarzbeck	HWRD 750	014	06 May 2017	12
A2892	Antenna	Schwarzbeck	BBHA 9170	9170-727	07 Apr 2017	12
A2863	Pre-Amplifier	Agilent	8449B	3008A02100	07 Jan 2017	12
A2891	Pre-Amplifier	Schwarzbeck	BBV 9718	9718-306	07 Apr 2017	12
A2893	Pre-Amplifier	Schwarzbeck	BBV 9721	9721-021	07 Apr 2017	12
S0582	Power Supply	Schwarzbeck	PS9721	00005	Calibrated before use	-
A2914	High Pass Filter	AtlanTecRF	AFH-03000	2155	19 May 2017	12
A2918	Attenuator	AtlanTecRF	AN185W-20	832828#1	19 May 2017	12

**5.2.7. Transmitter Radiated Emissions at Band Edges - LAT****Test Summary:**

<b>Test Engineers:</b>	David Doyle & Andrew Edwards	<b>Test Date:</b>	29 June 2016
<b>Test Sample IMEI:</b>	358640070087480		

<b>FCC Reference:</b>	Parts 2.1053 & 27.53(m)(4)
<b>Test Method Used:</b>	KDB 971168 Section 6.1 referencing FCC Part 27.53(m)(6)

**Environmental Conditions:**

<b>Temperature (°C):</b>	25
<b>Relative Humidity (%):</b>	40

**Note(s):**

1. Measurements were performed with the EUT transmitting with QPSK and 16QAM modulation schemes, with resource blocks settings as detailed in section 4.3 of this report.
2. 5 MHz Channel bandwidth: In the first 1.0 MHz immediately outside and adjacent to the operating band, the test receiver resolution bandwidth was set to 100 kHz (>2% of the emission bandwidth) and video bandwidth of 300 kHz (three times the resolution bandwidth).
3. 10 MHz Channel bandwidth: In the first 1.0 MHz immediately outside and adjacent to the operating band, the test receiver resolution bandwidth was set to 200 kHz (>2% of the emission bandwidth) and video bandwidth of 1 MHz (as close to > three times the resolution bandwidth as the test receiver allowed).
4. 15 MHz Channel bandwidth: In the first 1.0 MHz immediately outside and adjacent to the operating band, the test receiver resolution bandwidth was set to 300 kHz (>2% of the emission bandwidth) and video bandwidth of 1 MHz (as close to > three times the resolution bandwidth as the test receiver allowed).
5. 20 MHz Channel bandwidth: In the first 1.0 MHz immediately outside and adjacent to the operating band, the test receiver resolution bandwidth was set to 500 kHz (>2% of the emission bandwidth) and video bandwidth of 2 MHz (as close to > three times the resolution bandwidth as the test receiver allowed).

**Transmitter Radiated Emissions at Band Edges (continued)**

**Results: 5 MHz Channel Bandwidth / QPSK**

Frequency (MHz)	Resource Block(s)	Resource Block Offset	Emission Level (dBm)	Limit (dBm)	Margin (dB)	Result
2499.974	25	0	-38.4	-10.0	28.4	Complied
2500	25	0	-39.0	-10.0	29.0	Complied
2570	25	0	-31.7	-10.0	21.7	Complied
2570.024	25	0	-31.6	-10.0	21.6	Complied

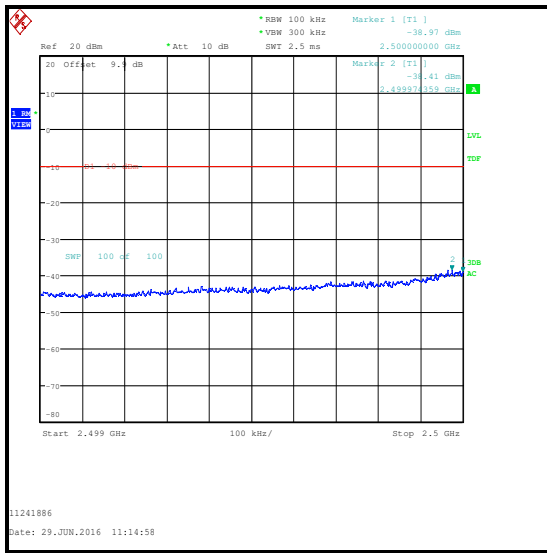

**QPSK / Lower Band Edge**

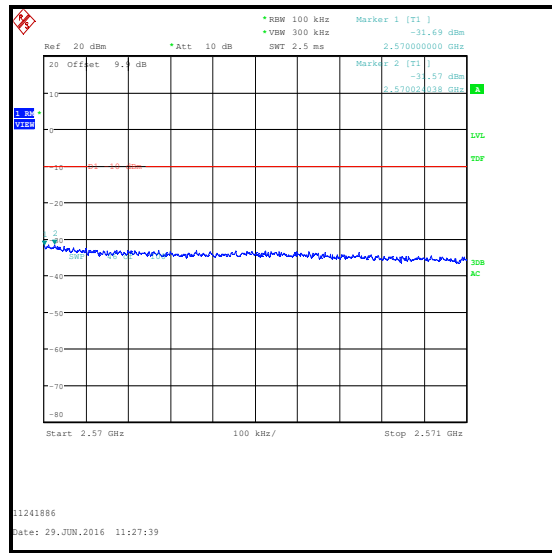

**QPSK / Upper Band Edge**

**Transmitter Radiated Emissions at Band Edges (continued)**

**Results: 5 MHz Channel Bandwidth / QPSK**

Frequency (MHz)	Resource Block(s)	Resource Block Offset	Emission Level (dBm)	Limit (dBm)	Margin (dB)	Result
2500	1	0	-36.4	-10.0	26.4	Complied
2570	1	24	-36.5	-10.0	26.5	Complied
2570.003	1	24	-36.0	-10.0	26.0	Complied
2500	1	24	-62.0	-10.0	52.0	Complied
2570	1	0	-61.9	-10.0	51.9	Complied

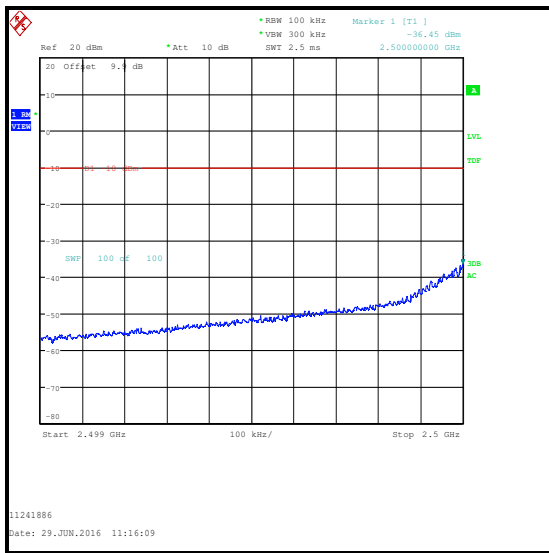

**QPSK / 1 RB 0 Offset / Lower Band Edge**

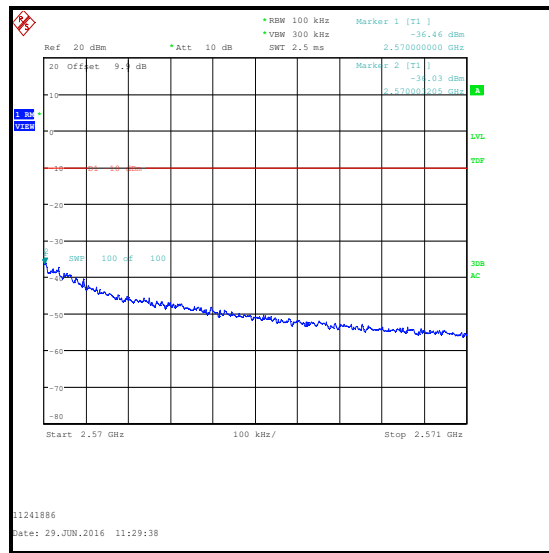

**QPSK / 1 RB 24 Offset / Upper Band Edge**

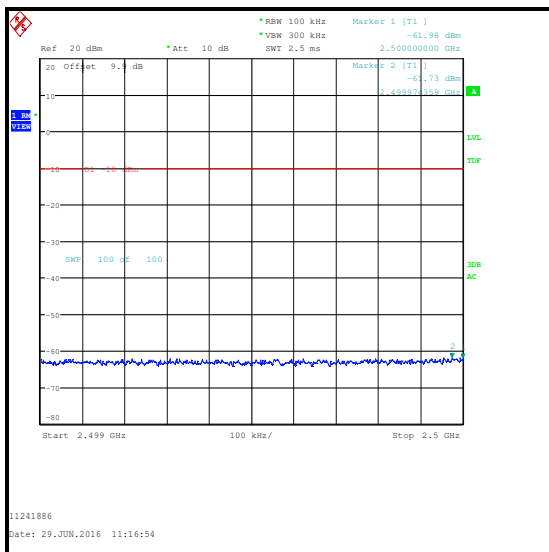

**QPSK / 1 RB 24 Offset / Lower Band Edge**

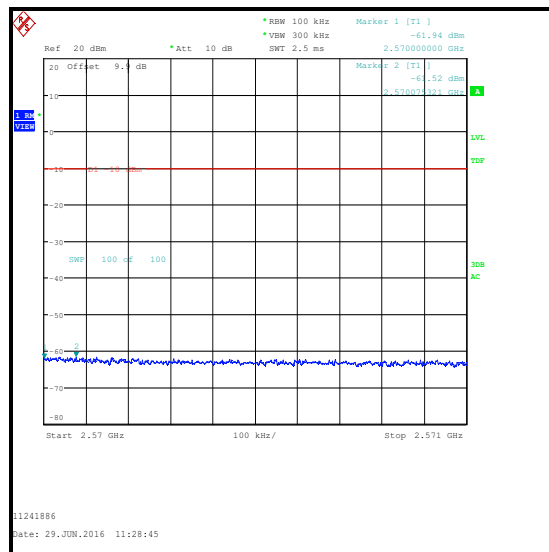

**QPSK / 1 RB 0 Offset / Upper Band Edge**

**Transmitter Radiated Emissions at Band Edges (continued)**

**Results: 5 MHz Channel Bandwidth / 16QAM**

Frequency (MHz)	Resource Block(s)	Resource Block Offset	Emission Level (dBm)	Limit (dBm)	Margin (dB)	Result
2500	25	0	-40.3	-10.0	30.3	Complied
2570	25	0	-34.2	-10.0	24.2	Complied
2570.003	25	0	-32.7	-10.0	22.7	Complied

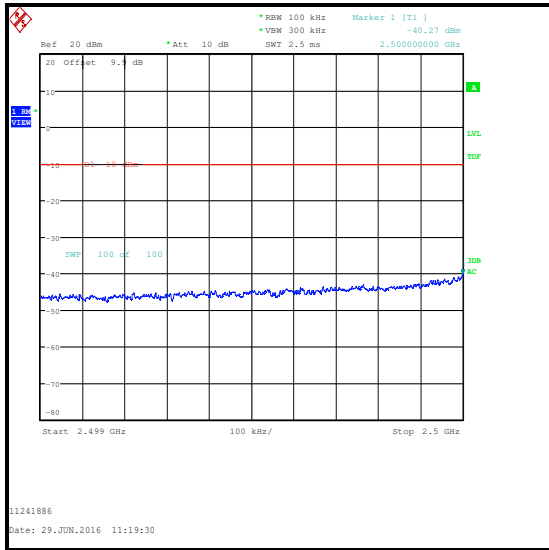

**16QAM / Lower Band Edge**

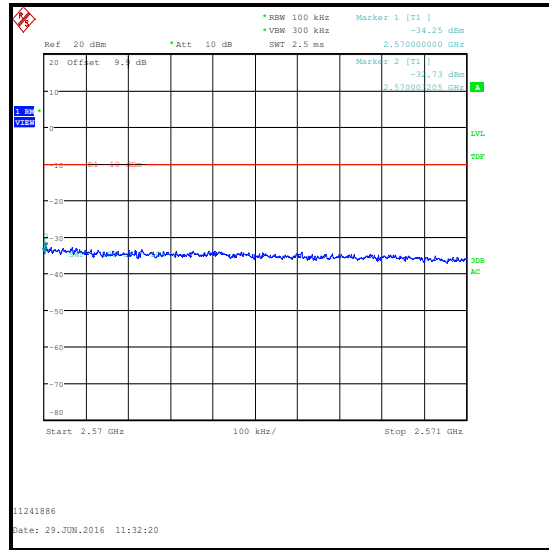

**16QAM / Upper Band Edge**

**Transmitter Radiated Emissions at Band Edges (continued)**

**Results: 5 MHz Channel Bandwidth / 16QAM**

Frequency (MHz)	Resource Block(s)	Resource Block Offset	Emission Level (dBm)	Limit (dBm)	Margin (dB)	Result
2500	1	0	-36.8	-10.0	26.8	Complied
2570	1	24	-37.9	-10.0	27.9	Complied
2570.006	1	24	-36.6	-10.0	26.6	Complied
2500	1	24	-62.3	-10.0	52.3	Complied
2570	1	0	-62.0	-10.0	52.0	Complied

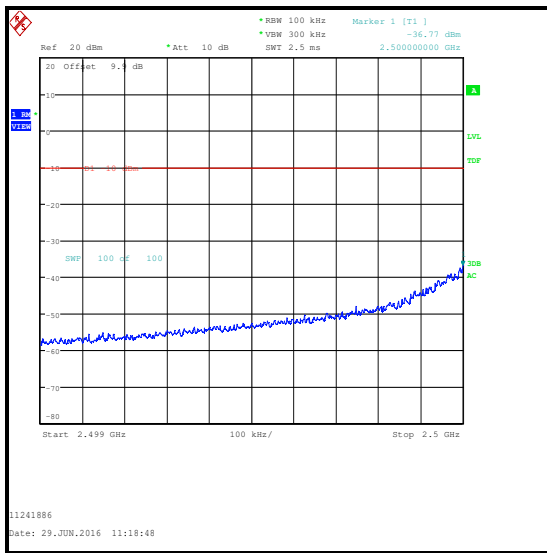

**16QAM / 1 RB 0 Offset / Lower Band Edge**

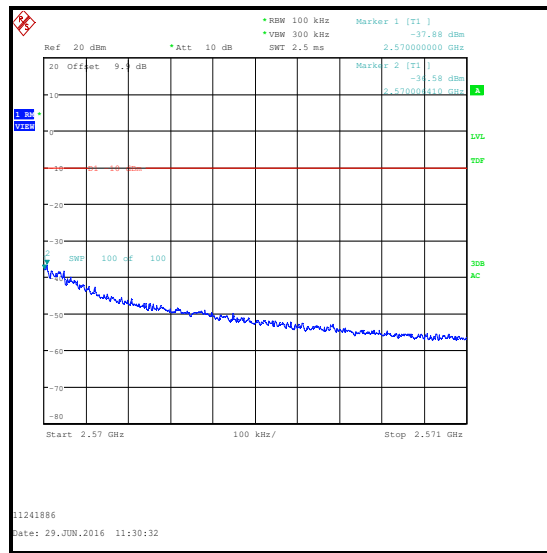

**16QAM / 1 RB 24 Offset / Upper Band Edge**

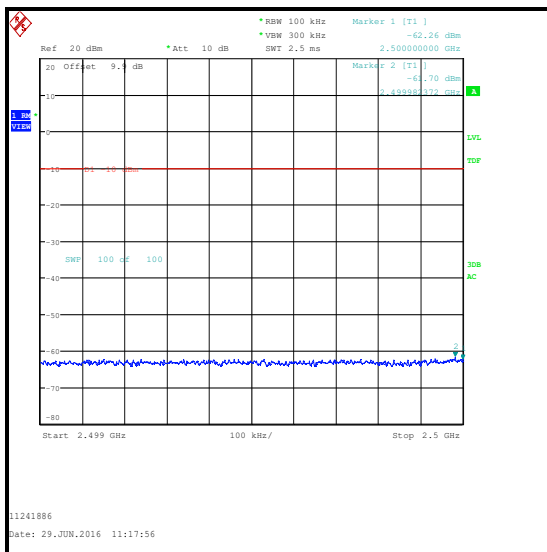

**16QAM / 1 RB 24 Offset / Lower Band Edge**

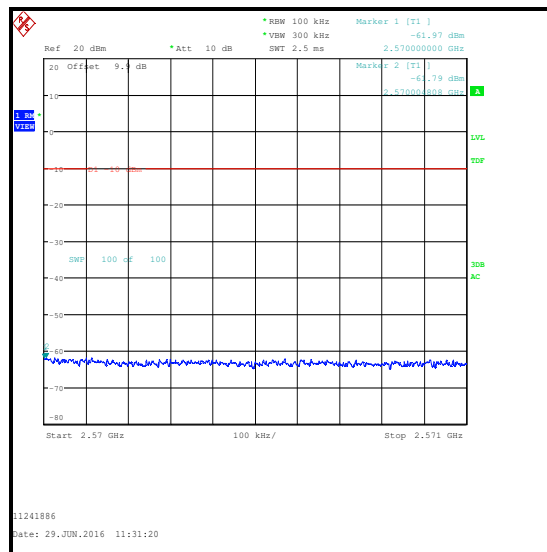

**16QAM / 1 RB 0 Offset / Upper Band Edge**

**Transmitter Radiated Emissions at Band Edges (continued)**

**Results: 10 MHz Channel Bandwidth / QPSK**

Frequency (MHz)	Resource Block(s)	Resource Block Offset	Emission Level (dBm)	Limit (dBm)	Margin (dB)	Result
2500	50	0	-29.8	-10.0	19.8	Complied
2570	50	0	-29.5	-10.0	19.5	Complied
2570.008	50	0	-29.4	-10.0	19.4	Complied

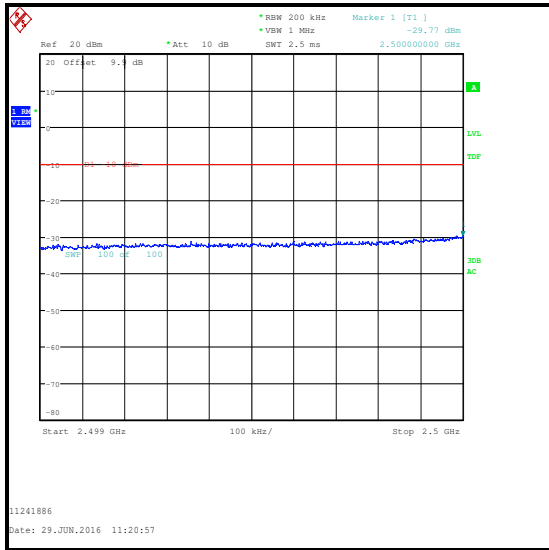

**QPSK / Lower Band Edge**

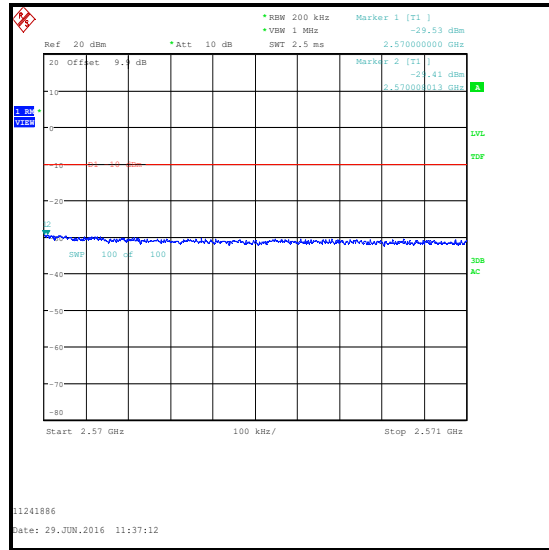

**QPSK / Upper Band Edge**

**Transmitter Radiated Emissions at Band Edges (continued)**

**Results: 10 MHz Channel Bandwidth / QPSK**

Frequency (MHz)	Resource Block(s)	Resource Block Offset	Emission Level (dBm)	Limit (dBm)	Margin (dB)	Result
2500	1	0	-20.7	-10.0	10.7	Complied
2570	1	49	-19.8	-10.0	9.8	Complied
2500	1	49	-57.7	-10.0	47.7	Complied
2570	1	0	-58.4	-10.0	48.4	Complied
2571	1	0	-57.4	-10.0	47.4	Complied

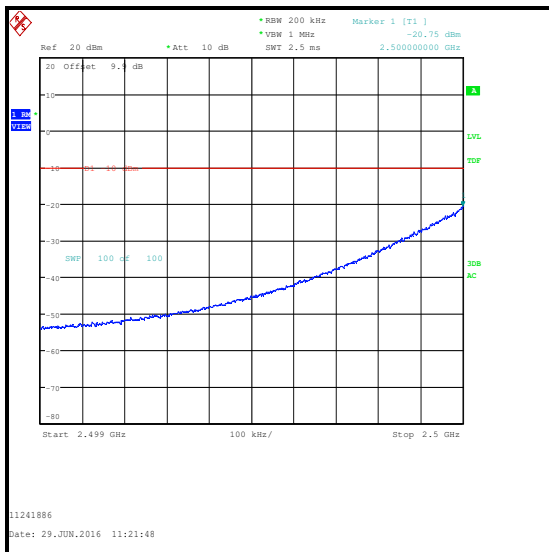

**QPSK / 1 RB 0 Offset / Lower Band Edge**



**QPSK / 1 RB 49 Offset / Upper Band Edge**

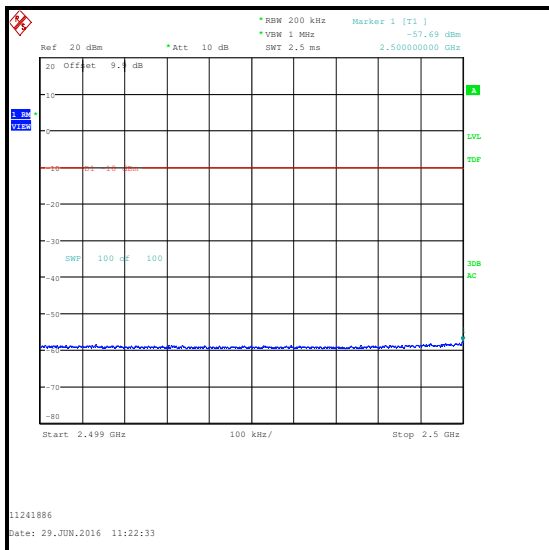

**QPSK / 1 RB 49 Offset / Lower Band Edge**

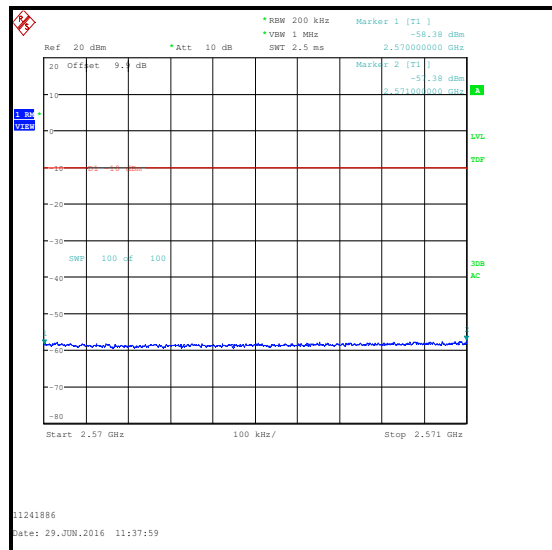

**QPSK / 1 RB 0 Offset / Upper Band Edge**

**Transmitter Radiated Emissions at Band Edges (continued)**

**Results: 10 MHz Channel Bandwidth / 16QAM**

Frequency (MHz)	Resource Block(s)	Resource Block Offset	Emission Level (dBm)	Limit (dBm)	Margin (dB)	Result
2500	50	0	-32.3	-10.0	22.3	Complied
2570	50	0	-31.0	-10.0	21.0	Complied
2570.013	50	0	-30.7	-10.0	20.7	Complied

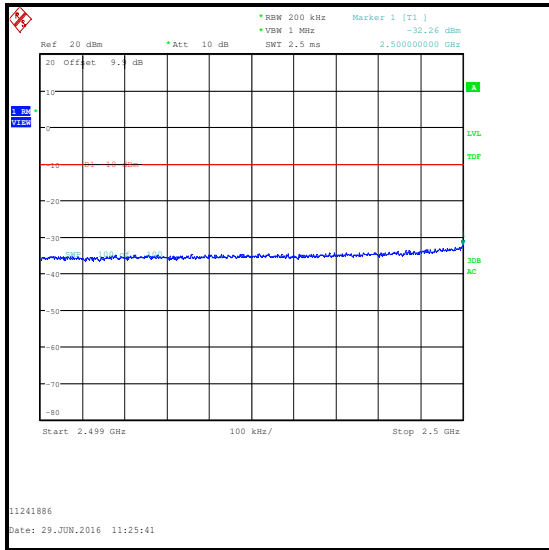

**16QAM / Lower Band Edge**

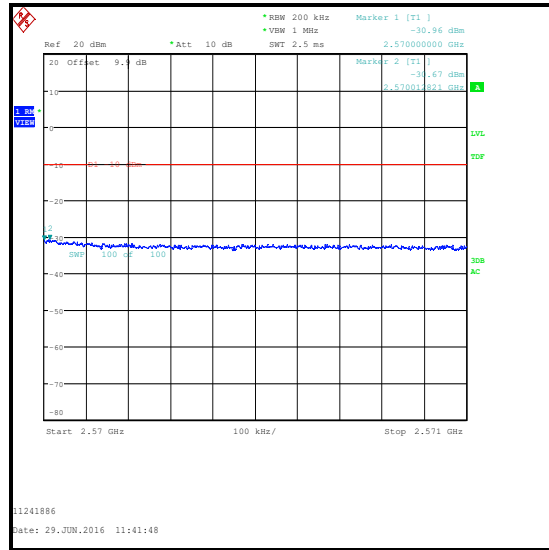

**16QAM / Upper Band Edge**

**Transmitter Radiated Emissions at Band Edges (continued)**

**Results: 10 MHz Channel Bandwidth / 16QAM**

Frequency (MHz)	Resource Block(s)	Resource Block Offset	Emission Level (dBm)	Limit (dBm)	Margin (dB)	Result
2500	1	0	-21.9	-10.0	11.9	Complied
2570	1	49	-21.3	-10.0	11.3	Complied
2500	1	49	-58.6	-10.0	48.6	Complied
2570	1	0	-58.9	-10.0	48.9	Complied

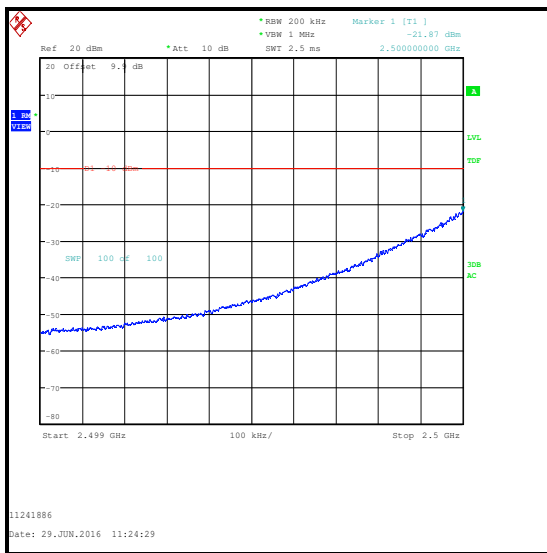

**16QAM / 1 RB 0 Offset / Lower Band Edge**

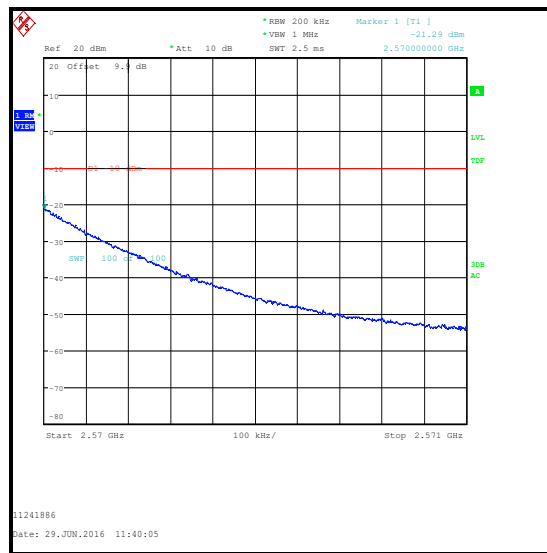

**16QAM / 1 RB 49 Offset / Upper Band Edge**

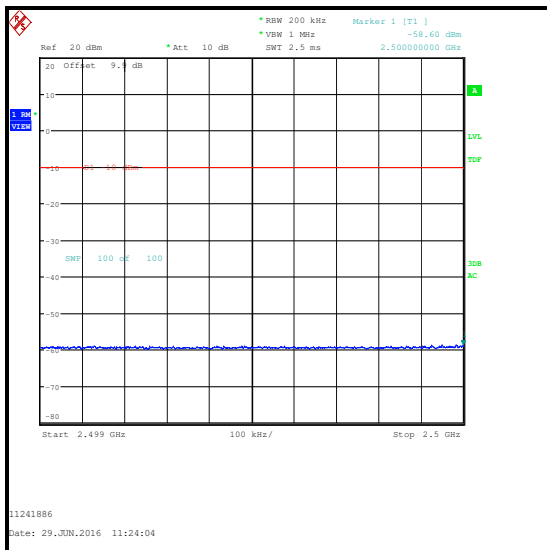

**16QAM / 1 RB 49 Offset / Lower Band Edge**

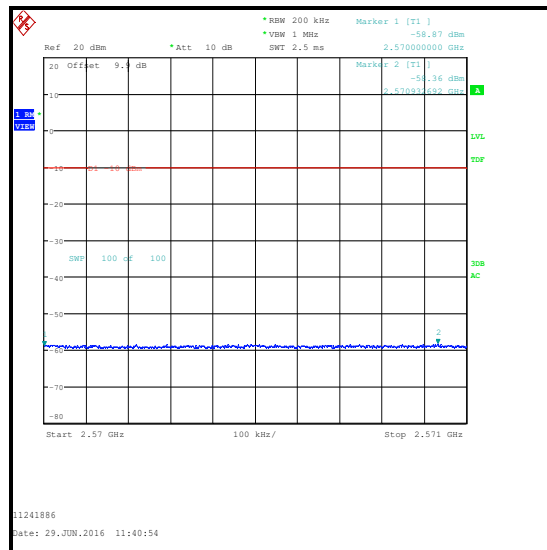

**16QAM / 1 RB 0 Offset / Upper Band Edge**

**Transmitter Radiated Emissions at Band Edges (continued)**

**Results: 15 MHz Channel Bandwidth / QPSK**

Frequency (MHz)	Resource Block(s)	Resource Block Offset	Emission Level (dBm)	Limit (dBm)	Margin (dB)	Result
2500	75	0	-29.9	-10.0	19.9	Complied
2570	75	0	-29.4	-10.0	19.4	Complied
2570.003	75	0	-29.2	-10.0	19.2	Complied

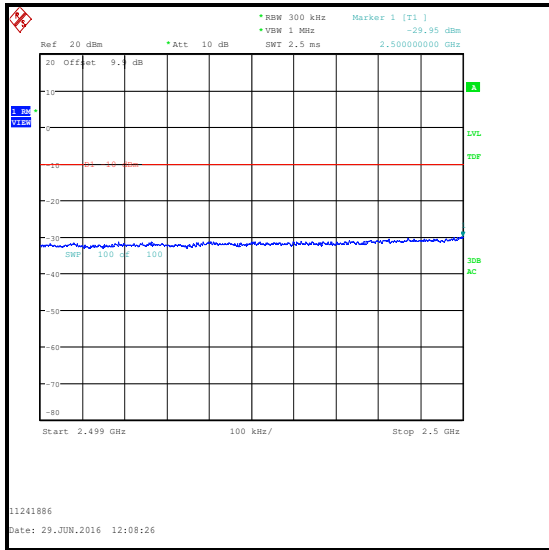

**QPSK / Lower Band Edge**

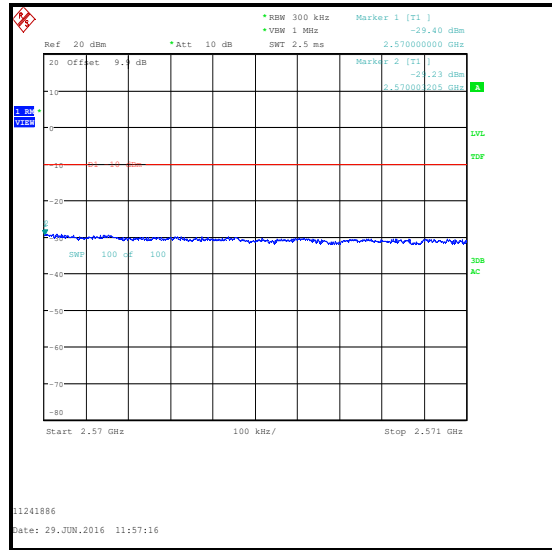

**QPSK / Upper Band Edge**

**Transmitter Radiated Emissions at Band Edges (continued)**

**Results: 15 MHz Channel Bandwidth / QPSK**

Frequency (MHz)	Resource Block(s)	Resource Block Offset	Emission Level (dBm)	Limit (dBm)	Margin (dB)	Result
2499.998	1	0	-20.4	-10.0	10.4	Complied
2500	1	0	-20.8	-10.0	10.8	Complied
2570	1	74	-19.7	-10.0	9.7	Complied
2500	1	74	-58.4	-10.0	48.4	Complied
2570	1	0	-58.4	-10.0	48.4	Complied

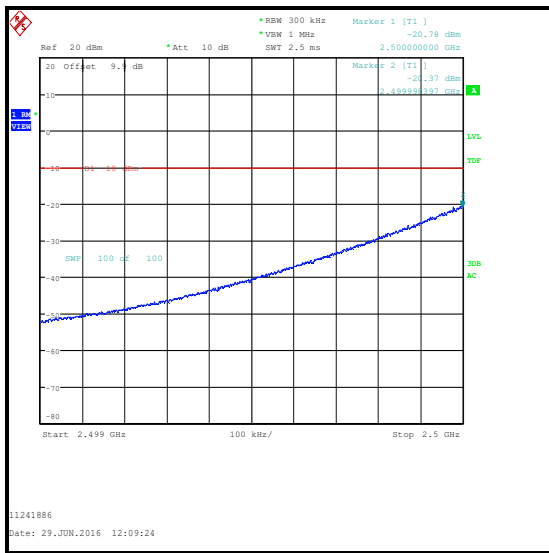

**QPSK / 1 RB 0 Offset / Lower Band Edge**

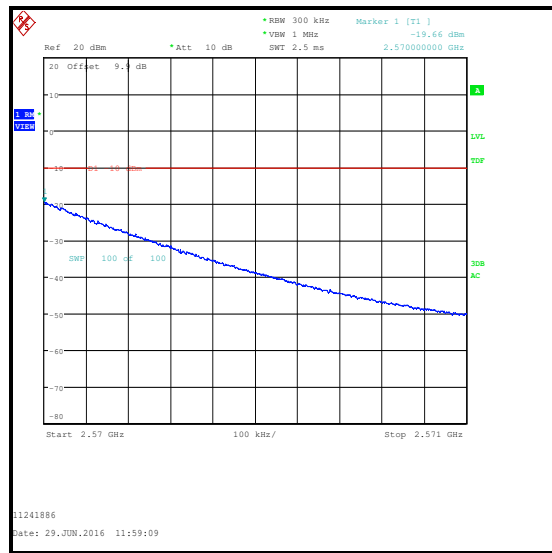

**QPSK / 1 RB 74 Offset / Upper Band Edge**

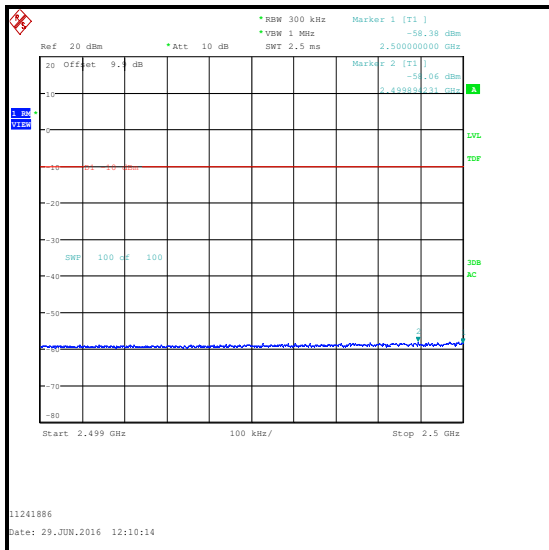

**QPSK / 1 RB 74 Offset / Lower Band Edge**

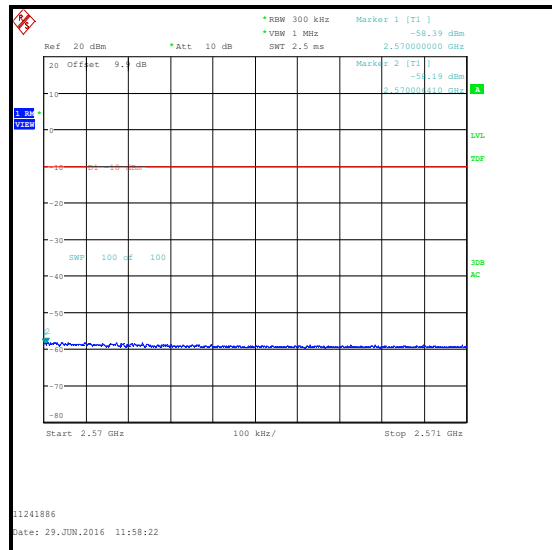

**QPSK / 1 RB 0 Offset / Upper Band Edge**

**Transmitter Radiated Emissions at Band Edges (continued)**

**Results: 15 MHz Channel Bandwidth / 16QAM**

Frequency (MHz)	Resource Block(s)	Resource Block Offset	Emission Level (dBm)	Limit (dBm)	Margin (dB)	Result
2499.973	75	0	-31.7	-10.0	21.7	Complied
2500	75	0	-32.6	-10.0	22.6	Complied
2570	75	0	-31.1	-10.0	21.1	Complied
2570.006	75	0	-30.6	-10.0	20.6	Complied

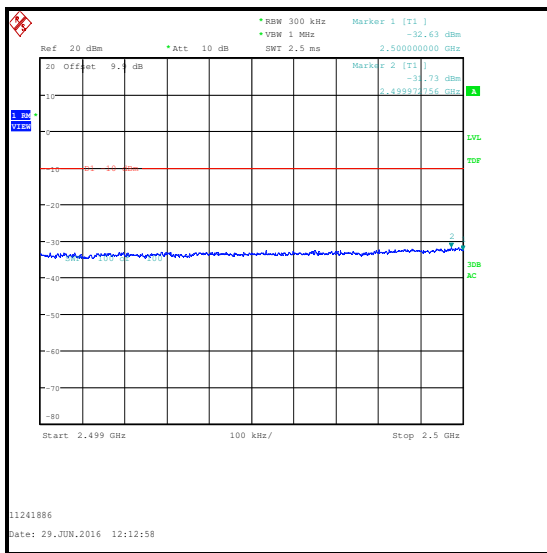

**16QAM / Lower Band Edge**

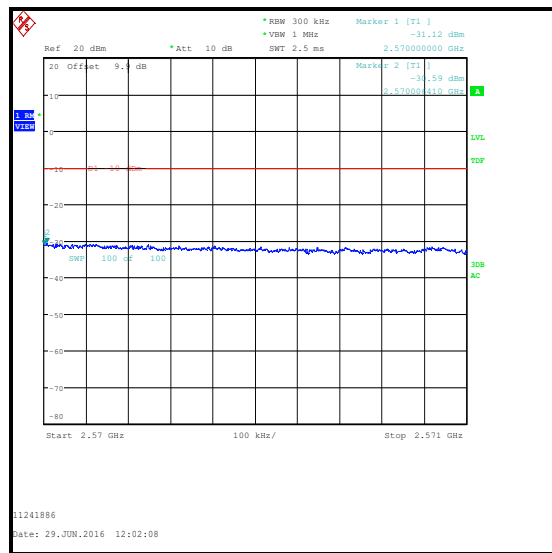

**16QAM / Upper Band Edge**

**Transmitter Radiated Emissions at Band Edges (continued)****Results: 15 MHz Channel Bandwidth / 16QAM**

Frequency (MHz)	Resource Block(s)	Resource Block Offset	Emission Level (dBm)	Limit (dBm)	Margin (dB)	Result
2499.997	1	0	-21.4	-10.0	11.4	Complied
2500	1	0	-21.6	-10.0	11.6	Complied
2570	1	74	-21.2	-10.0	11.2	Complied
2570.005	1	74	-20.5	-10.0	10.5	Complied
2500	1	74	-59.0	-10.0	49.0	Complied
2570	1	0	-58.6	-10.0	48.6	Complied

### Transmitter Radiated Emissions at Band Edges (continued)

#### Results: 15 MHz Channel Bandwidth / 16QAM



16QAM / 1 RB 0 Offset / Lower Band Edge

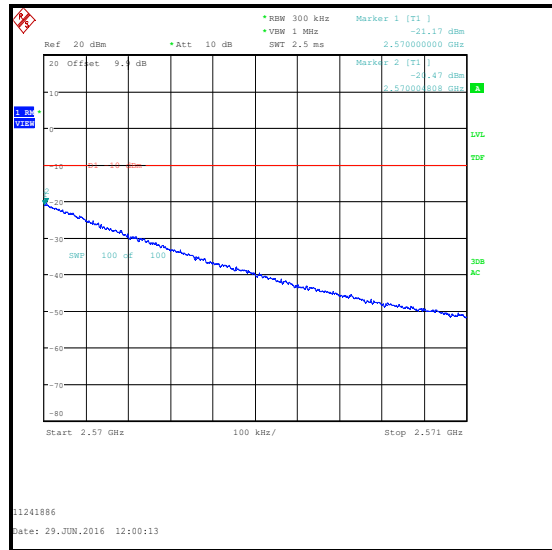

16QAM / 1 RB 74 Offset / Upper Band Edge

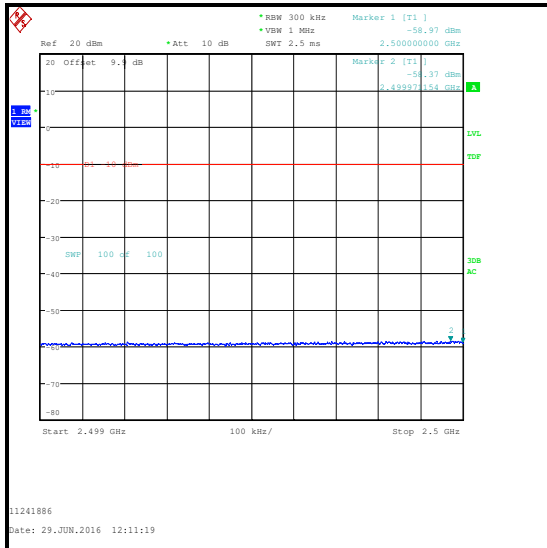

16QAM / 1 RB 74 Offset / Lower Band Edge

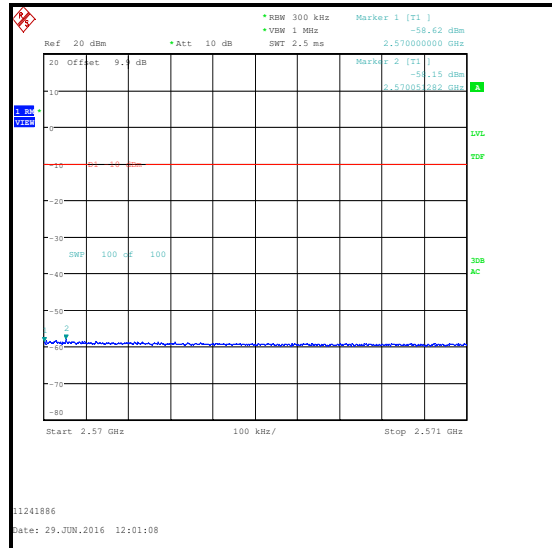

16QAM / 1 RB 0 Offset / Upper Band Edge

**Transmitter Radiated Emissions at Band Edges (continued)**

**Results: 20 MHz Channel Bandwidth / QPSK**

Frequency (MHz)	Resource Block(s)	Resource Block Offset	Emission Level (dBm)	Limit (dBm)	Margin (dB)	Result
2499.995	100	0	-27.3	-10.0	17.3	Complied
2500	100	0	-27.4	-10.0	17.4	Complied
2570	100	0	-26.5	-10.0	16.5	Complied

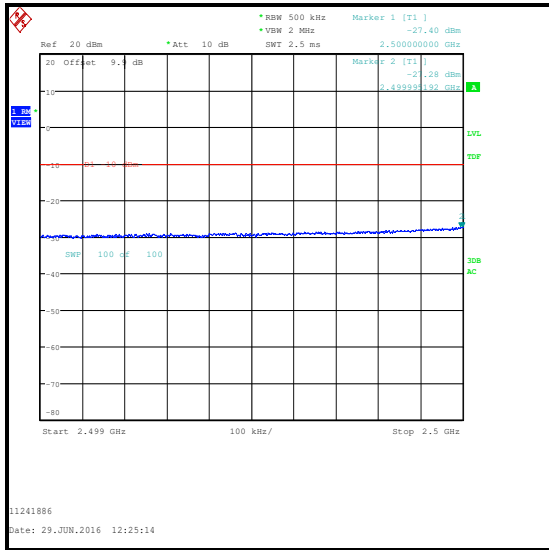

**QPSK / Lower Band Edge**

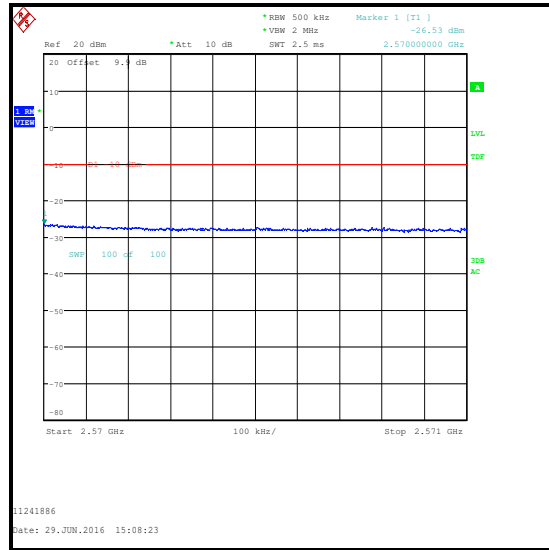

**QPSK / Upper Band Edge**

**Transmitter Radiated Emissions at Band Edges (continued)**

**Results: 20 MHz Channel Bandwidth / QPSK**

Frequency (MHz)	Resource Block(s)	Resource Block Offset	Emission Level (dBm)	Limit (dBm)	Margin (dB)	Result
2500	1	0	-13.8	-10.0	3.8	Complied
2570	1	99	-13.0	-10.0	3.0	Complied
2570.003	1	99	-12.7	-10.0	2.7	Complied
2500	1	99	-56.1	-10.0	46.1	Complied
2570	1	0	-55.7	-10.0	45.7	Complied

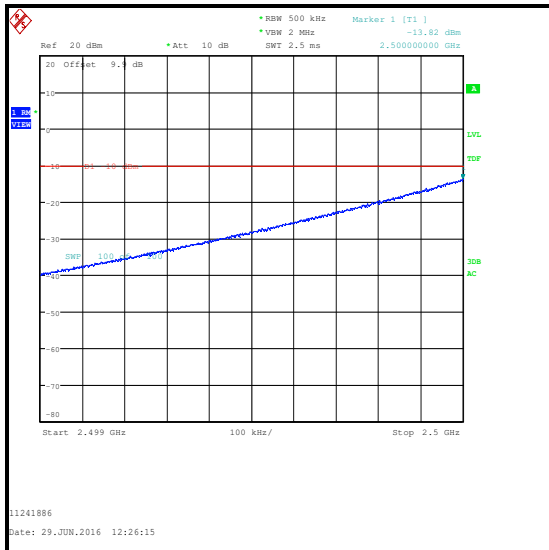

**QPSK / 1 RB 0 Offset / Lower Band Edge**

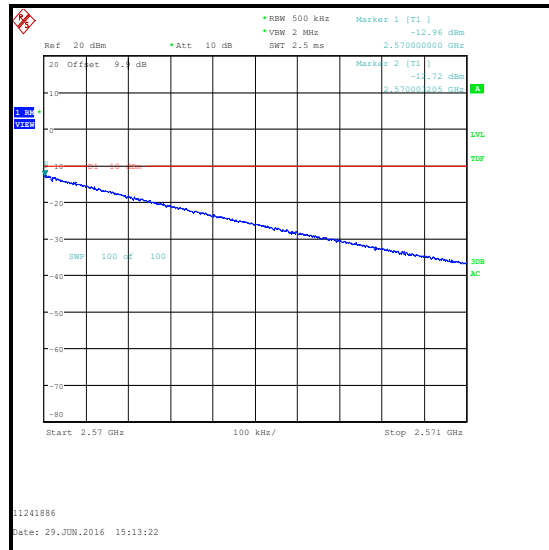

**QPSK / 1 RB 99 Offset / Lower Band Edge**

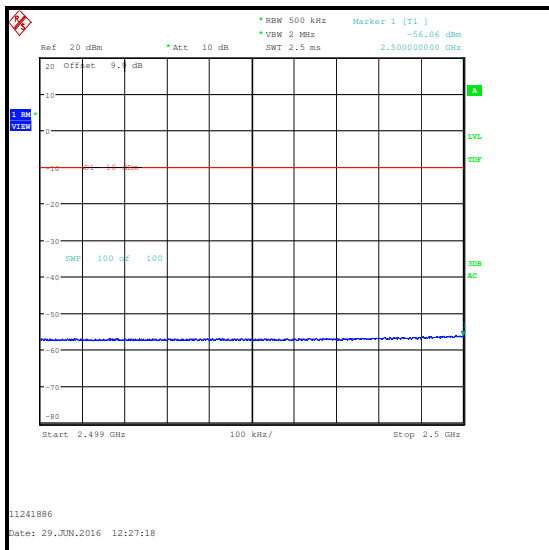

**QPSK / 1 RB 99 Offset / Upper Band Edge**

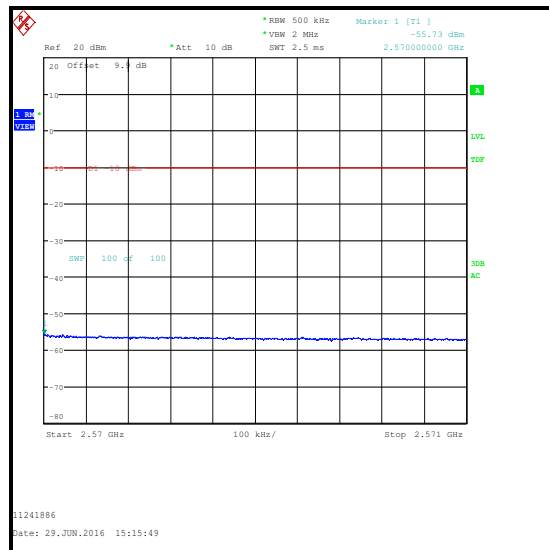

**QPSK / 1 RB 0 Offset / Upper Band Edge**

**Transmitter Radiated Emissions at Band Edges (continued)**

**Results: 20 MHz Channel Bandwidth / 16QAM**

Frequency (MHz)	Resource Block(s)	Resource Block Offset	Emission Level (dBm)	Limit (dBm)	Margin (dB)	Result
2499.981	100	0	-25.8	-10.0	15.8	Complied
2500	100	0	-25.9	-10.0	15.9	Complied
2570	100	0	-27.7	-10.0	17.7	Complied

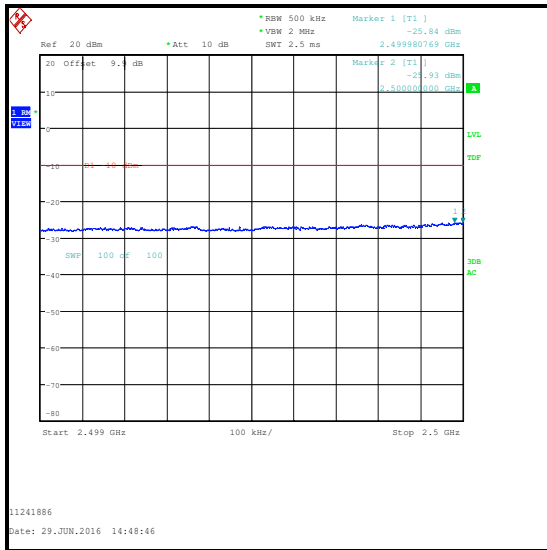

**16QAM / Lower Band Edge**

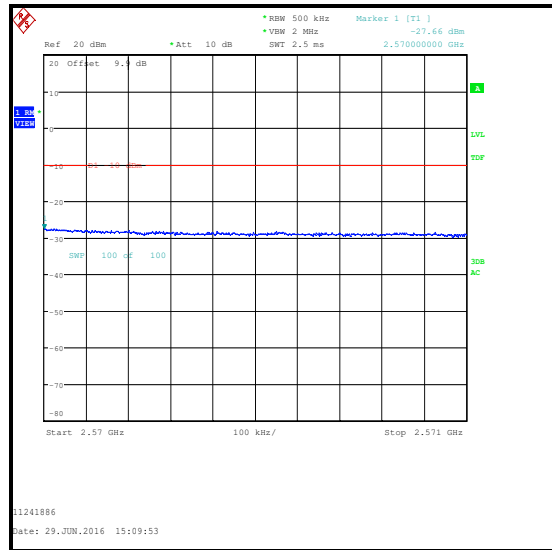

**16QAM / Upper Band Edge**

**Transmitter Radiated Emissions at Band Edges (continued)****Results: 20 MHz Channel Bandwidth / 16QAM**

Frequency (MHz)	Resource Block(s)	Resource Block Offset	Emission Level (dBm)	Limit (dBm)	Margin (dB)	Result
2499.989	1	0	-12.1	-10.0	2.1	Complied
2500	1	0	-12.5	-10.0	2.5	Complied
2570	1	99	-13.9	-10.0	3.9	Complied
2570.006	1	99	-13.8	-10.0	3.8	Complied
2500	1	99	-56.0	-10.0	46.0	Complied
2570	1	0	-56.0	-10.0	46.0	Complied

**Transmitter Radiated Emissions at Band Edges (continued)**

**Results: 20 MHz Channel Bandwidth / 16QAM**

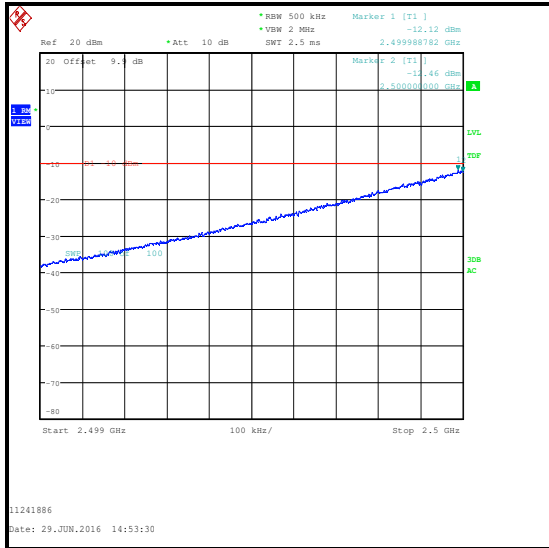

**16QAM / 1 RB 0 Offset / Lower Band Edge**

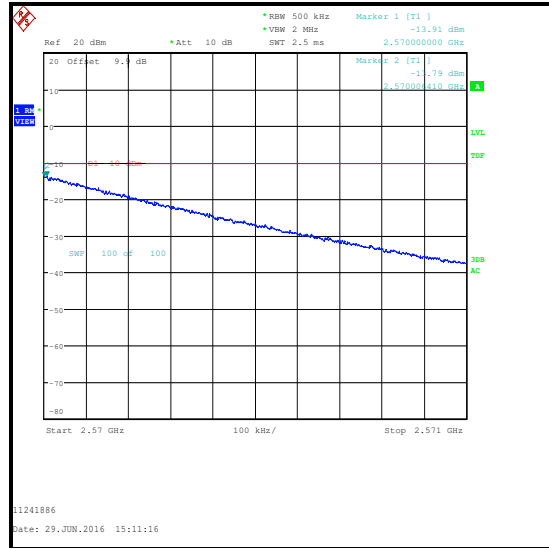

**16QAM / 1 RB 99 Offset / Upper Band Edge**

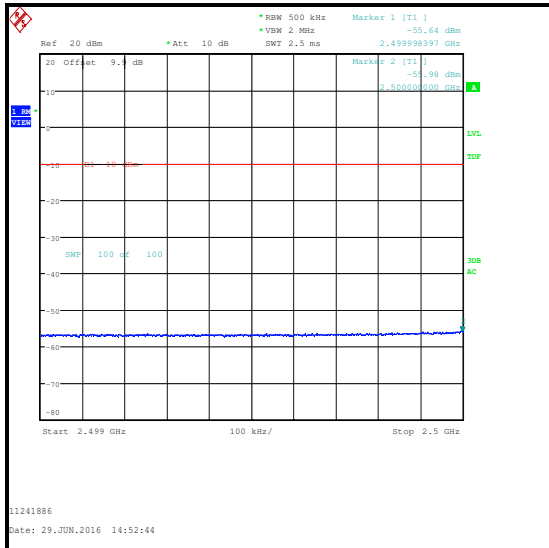

**16QAM / 1 RB 99 Offset / Lower Band Edge**

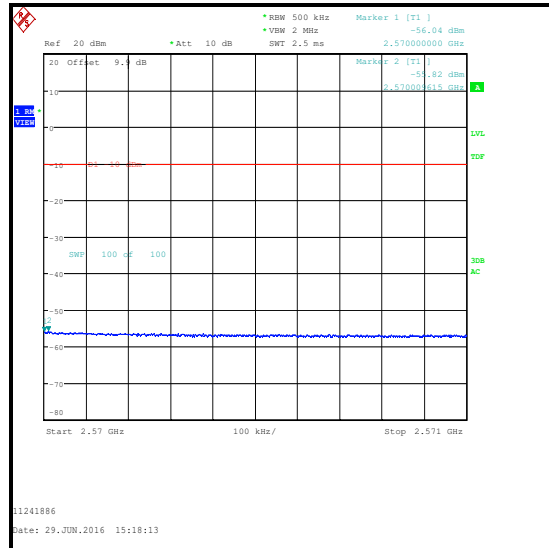

**16QAM / 1 RB 0 Offset / Upper Band Edge**

**Test Equipment Used:**

Asset No.	Instrument	Manufacturer	Type No.	Serial No.	Date Calibration Due	Cal. Interval (Months)
M2003	Thermohyrometer	Testo	608-H1	45046641	22 Apr 2017	12
K0017	3m RSE Chamber	Rainford EMC	N/A	N/A	17 May 2017	12
M1995	Test Receiver	Rohde & Schwarz	ESU40	100428	21 Mar 2017	12
A2893	Pre-Amplifier	Schwarzbeck	BBV 9721	9721-021	07 Apr 2017	12
A2889	Antenna	Schwarzbeck	BBHA 9120 B	BBHA 9120 B 653	07 Apr 2017	12
A2916	Attenuator	AtlanTecRF	AN18W5-10	832827#1	19 May 2017	12

**5.2.8. Transmitter Radiated Emissions at Band Edges - UAT****Test Summary:**

<b>Test Engineer:</b>	Andrew Edwards	<b>Test Date:</b>	29 June 2016
<b>Test Sample IMEI:</b>	358640070022890		

<b>FCC Reference:</b>	Parts 2.1053 & 27.53(m)(4)
<b>Test Method Used:</b>	KDB 971168 Section 6.1 referencing FCC Part 27.53(m)(6)

**Environmental Conditions:**

<b>Temperature (°C):</b>	25
<b>Relative Humidity (%):</b>	40

**Note(s):**

1. Measurements were performed with the EUT transmitting with QPSK and 16QAM modulation schemes, with resource blocks settings as detailed in section 4.3 of this report.
2. 5 MHz Channel bandwidth: In the first 1.0 MHz immediately outside and adjacent to the operating band, the test receiver resolution bandwidth was set to 100 kHz (>2% of the emission bandwidth) and video bandwidth of 300 kHz (three times the resolution bandwidth).
3. 10 MHz Channel bandwidth: In the first 1.0 MHz immediately outside and adjacent to the operating band, the test receiver resolution bandwidth was set to 200 kHz (>2% of the emission bandwidth) and video bandwidth of 1 MHz (as close to > three times the resolution bandwidth as the test receiver allowed).
4. 15 MHz Channel bandwidth: In the first 1.0 MHz immediately outside and adjacent to the operating band, the test receiver resolution bandwidth was set to 300 kHz (>2% of the emission bandwidth) and video bandwidth of 1 MHz (as close to > three times the resolution bandwidth as the test receiver allowed).
5. 20 MHz Channel bandwidth: In the first 1.0 MHz immediately outside and adjacent to the operating band, the test receiver resolution bandwidth was set to 500 kHz (>2% of the emission bandwidth) and video bandwidth of 2 MHz (as close to > three times the resolution bandwidth as the test receiver allowed).

**Transmitter Radiated Emissions at Band Edges (continued)**

**Results: 5 MHz Channel Bandwidth / QPSK**

Frequency (MHz)	Resource Block(s)	Resource Block Offset	Emission Level (dBm)	Limit (dBm)	Margin (dB)	Result
2499.998	25	0	-32.6	-10.0	22.6	Complied
2500	25	0	-32.4	-10.0	22.4	Complied
2570	25	0	-30.5	-10.0	20.5	Complied
2570.005	25	0	-30.0	-10.0	20.0	Complied

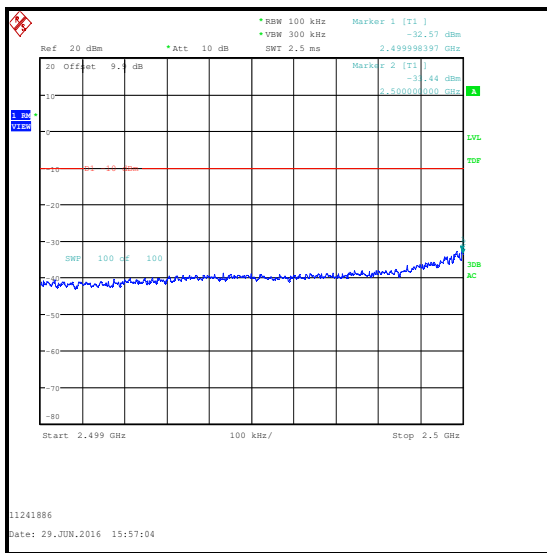

**QPSK / Lower Band Edge**

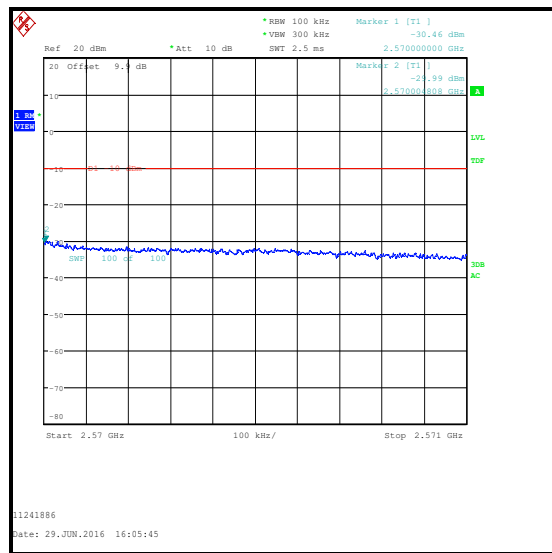

**QPSK / Upper Band Edge**

**Transmitter Radiated Emissions at Band Edges (continued)****Results: 5 MHz Channel Bandwidth / QPSK**

Frequency (MHz)	Resource Block(s)	Resource Block Offset	Emission Level (dBm)	Limit (dBm)	Margin (dB)	Result
2499.995	1	0	-24.9	-10.0	14.9	Complied
2500	1	0	-25.1	-10.0	15.1	Complied
2570	1	24	-27.0	-10.0	17.0	Complied
2570.005	1	24	-26.1	-10.0	16.1	Complied
2500	1	24	-60.8	-10.0	50.8	Complied
2570	1	0	-60.6	-10.0	50.6	Complied

### Transmitter Radiated Emissions at Band Edges (continued)

#### Results: 5 MHz Channel Bandwidth / QPSK

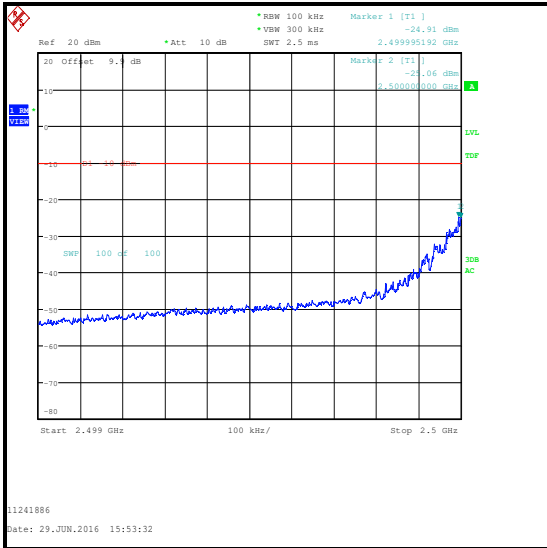

QPSK / 1 RB 0 Offset / Lower Band Edge

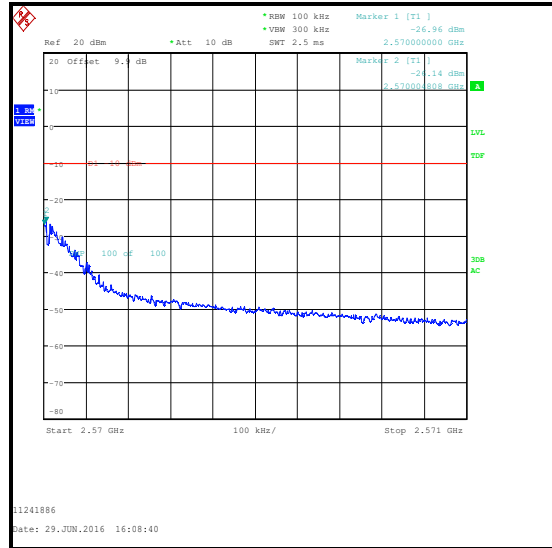

QPSK / 1 RB 24 Offset / Upper Band Edge

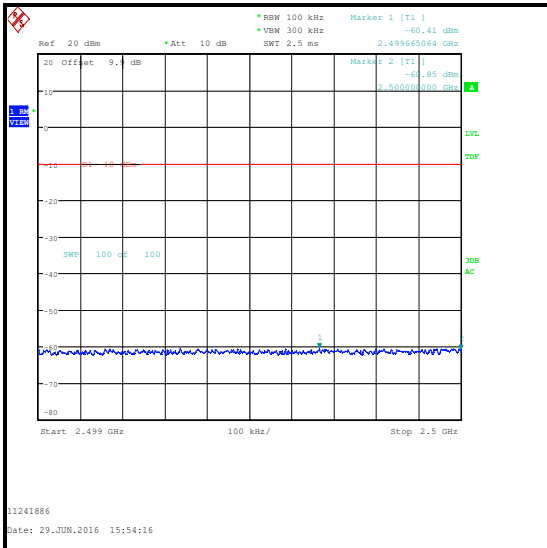

QPSK / 1 RB 24 Offset / Lower Band Edge

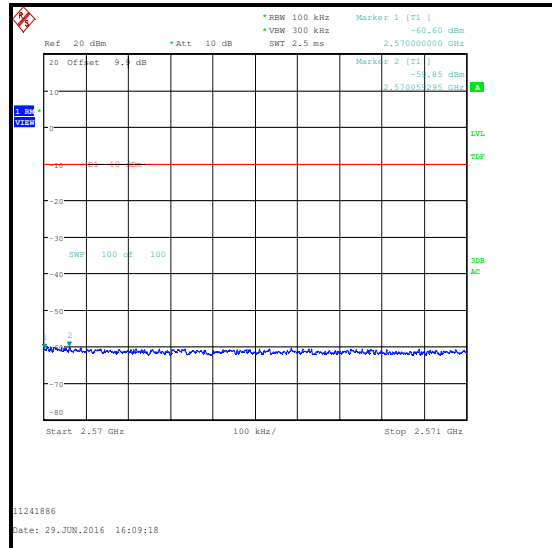

QPSK / 1 RB 0 Offset / Upper Band Edge

**Transmitter Radiated Emissions at Band Edges (continued)**

**Results: 5 MHz Channel Bandwidth / 16QAM**

Frequency (MHz)	Resource Block(s)	Resource Block Offset	Emission Level (dBm)	Limit (dBm)	Margin (dB)	Result
2499.994	25	0	-34.6	-10.0	24.6	Complied
2500	25	0	-35.9	-10.0	25.9	Complied
2570	25	0	-32.6	-10.0	22.6	Complied
2570.002	25	0	-31.1	-10.0	21.1	Complied

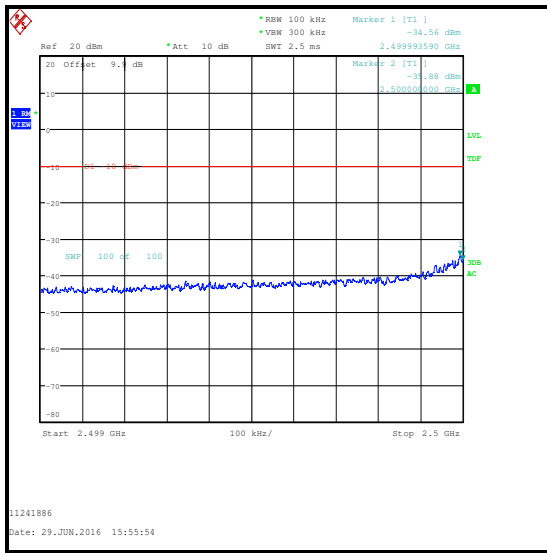

**16QAM / Lower Band Edge**

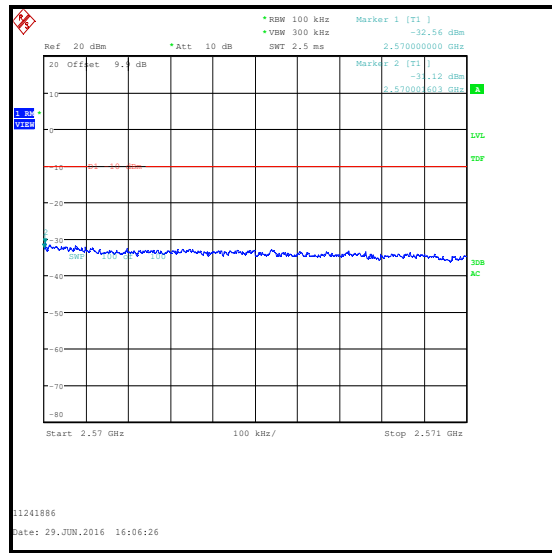

**16QAM / Upper Band Edge**

**Transmitter Radiated Emissions at Band Edges (continued)**

**Results: 5 MHz Channel Bandwidth / 16QAM**

Frequency (MHz)	Resource Block(s)	Resource Block Offset	Emission Level (dBm)	Limit (dBm)	Margin (dB)	Result
2499.990	1	0	-25.6	-10.0	15.6	Complied
2500	1	0	-25.7	-10.0	15.7	Complied
2570	1	24	-27.0	-10.0	17.0	Complied
2500	1	24	-61.2	-10.0	51.2	Complied
2570	1	0	-60.9	-10.0	50.9	Complied

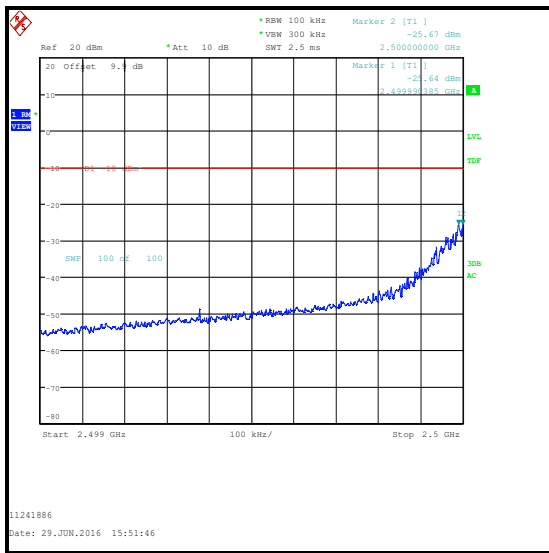

**16QAM / 1 RB 0 Offset / Lower Band Edge**

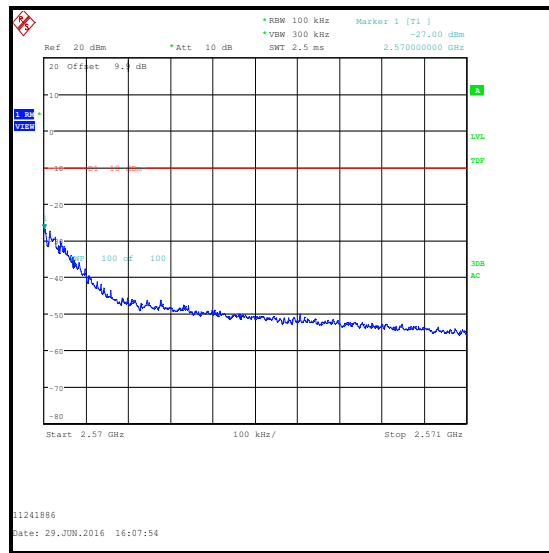

**16QAM / 1 RB 24 Offset / Upper Band Edge**

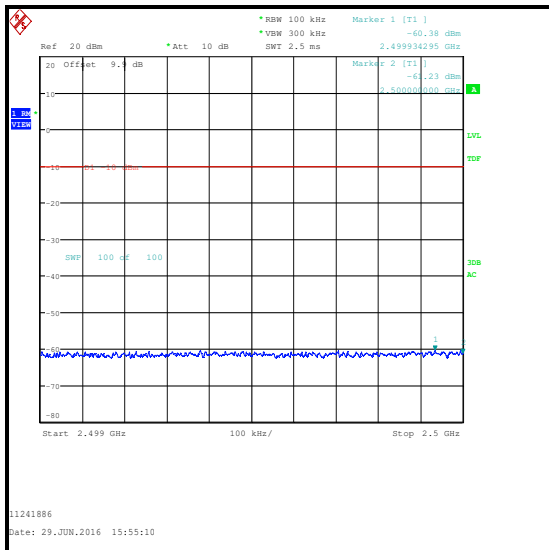

**16QAM / 1 RB 24 Offset / Lower Band Edge**

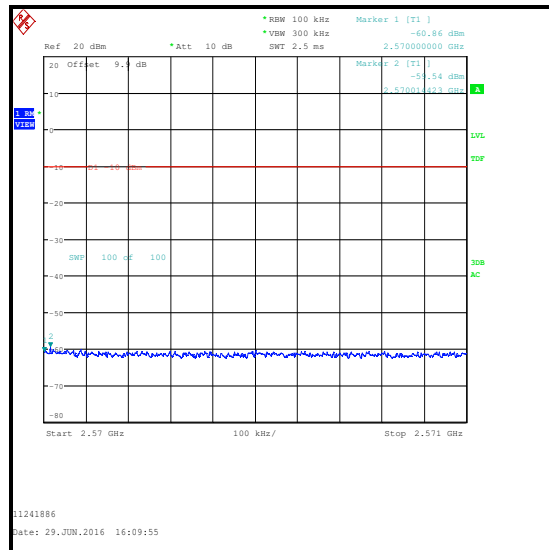

**16QAM / 1 RB 0 Offset / Upper Band Edge**

**Transmitter Radiated Emissions at Band Edges (continued)**

**Results: 10 MHz Channel Bandwidth / QPSK**

Frequency (MHz)	Resource Block(s)	Resource Block Offset	Emission Level (dBm)	Limit (dBm)	Margin (dB)	Result
2499.987	50	0	-30.3	-10.0	20.3	Complied
2500	50	0	-30.6	-10.0	20.6	Complied
2570	50	0	-27.9	-10.0	17.9	Complied
2570.011	50	0	-27.3	-10.0	17.3	Complied

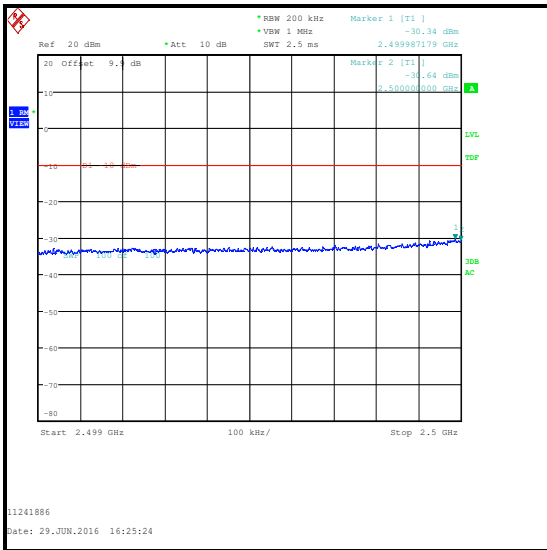

**QPSK / Lower Band Edge**

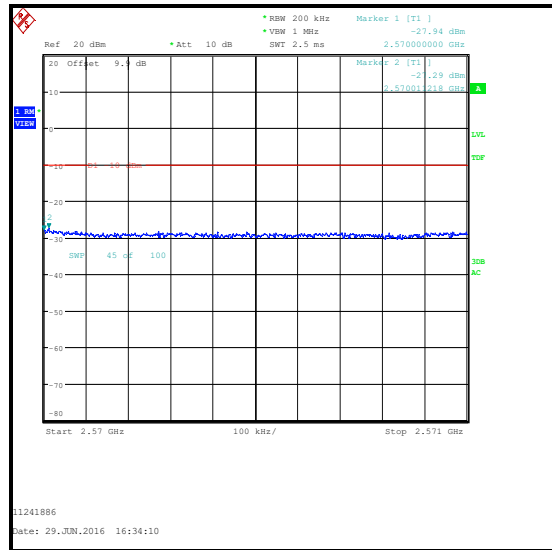

**QPSK / Upper Band Edge**

**Transmitter Radiated Emissions at Band Edges (continued)****Results: 10 MHz Channel Bandwidth / QPSK**

Frequency (MHz)	Resource Block(s)	Resource Block Offset	Emission Level (dBm)	Limit (dBm)	Margin (dB)	Result
2499.998	1	0	-21.0	-10.0	11.0	Complied
2500	1	0	-21.3	-10.0	11.3	Complied
2570	1	49	-20.7	-10.0	10.7	Complied
2570.011	1	49	-20.2	-10.0	10.2	Complied
2500	1	49	-57.1	-10.0	47.1	Complied
2570	1	0	-57.0	-10.0	47.0	Complied

### Transmitter Radiated Emissions at Band Edges (continued)

#### Results: 10 MHz Channel Bandwidth / QPSK

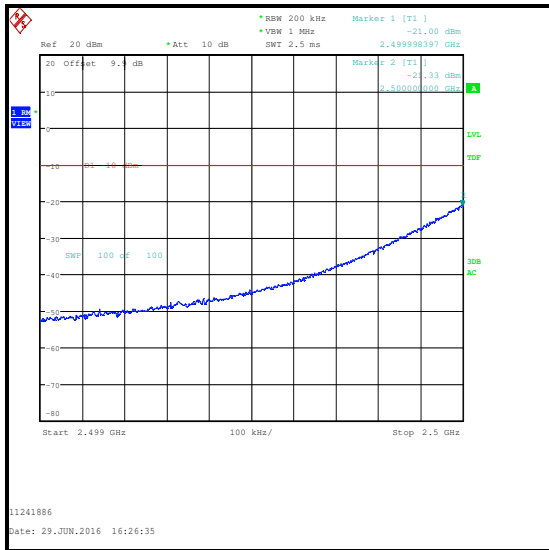

QPSK / 1 RB 0 Offset / Lower Band Edge

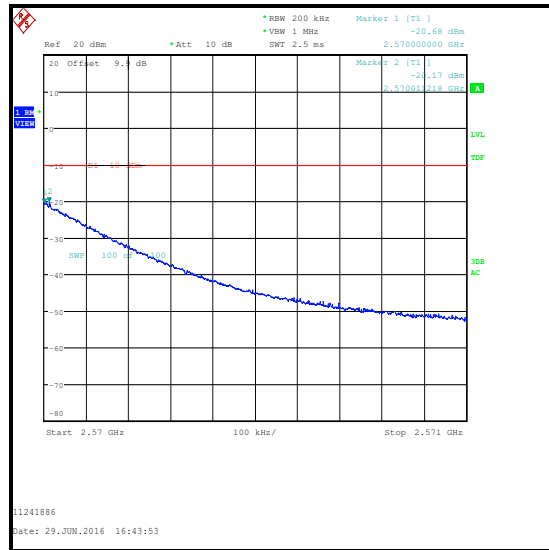

QPSK / 1 RB 49 Offset / Upper Band Edge

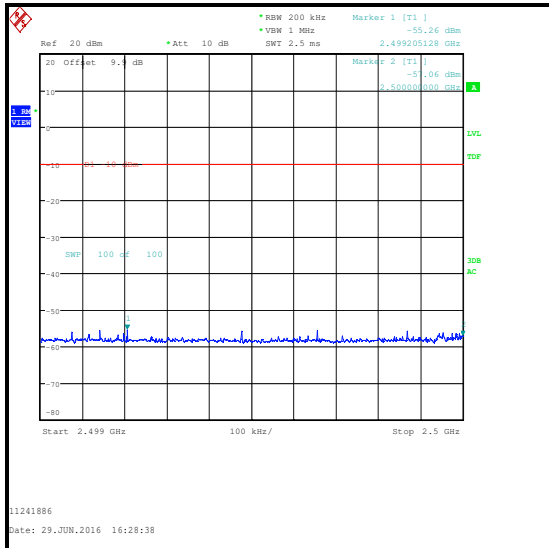

QPSK / 1 RB 49 Offset / Lower Band Edge

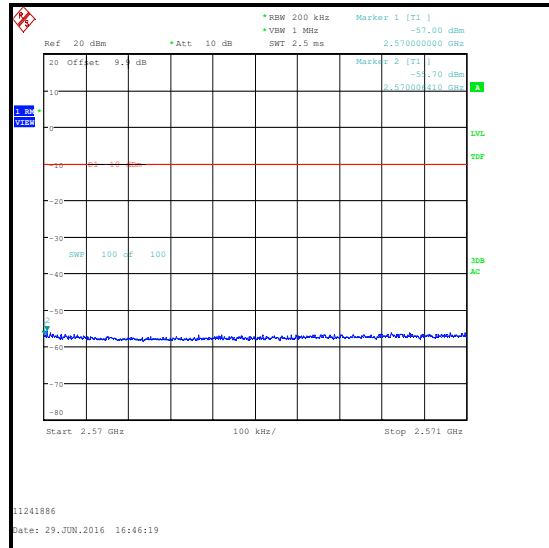

QPSK / 1 RB 0 Offset / Upper Band Edge

**Transmitter Radiated Emissions at Band Edges (continued)**

**Results: 10 MHz Channel Bandwidth / 16QAM**

Frequency (MHz)	Resource Block(s)	Resource Block Offset	Emission Level (dBm)	Limit (dBm)	Margin (dB)	Result
2499.997	50	0	-32.5	-10.0	22.5	Complied
2500	50	0	-33.4	-10.0	23.4	Complied
2570	50	0	-29.7	-10.0	19.7	Complied
2570.011	50	0	-29.5	-10.0	19.5	Complied

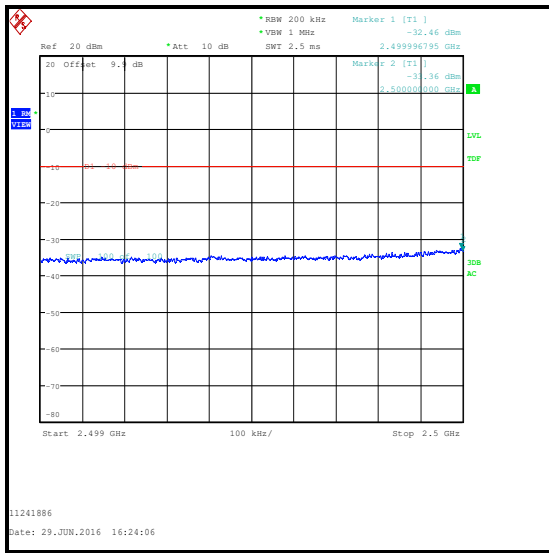

**16QAM / Lower Band Edge**

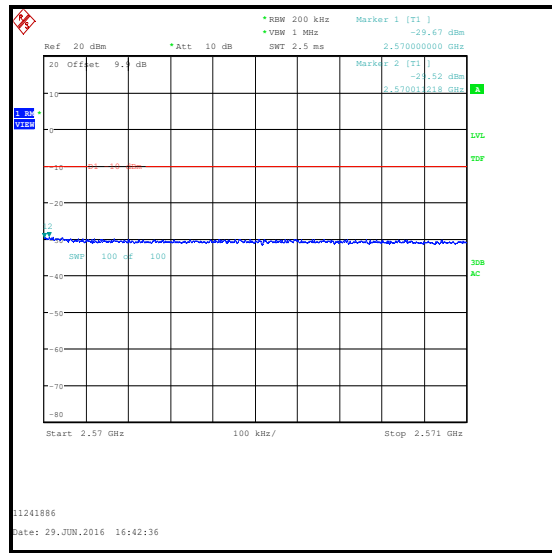

**16QAM / Upper Band Edge**

**Transmitter Radiated Emissions at Band Edges (continued)**

**Results: 10 MHz Channel Bandwidth / 16QAM**

Frequency (MHz)	Resource Block(s)	Resource Block Offset	Emission Level (dBm)	Limit (dBm)	Margin (dB)	Result
2499.998	1	0	-21.1	-10.0	11.1	Complied
2500	1	0	-21.5	-10.0	11.5	Complied
2570	1	49	-21.4	-10.0	11.4	Complied
2500	1	49	-58.3	-10.0	48.3	Complied
2570	1	0	-57.9	-10.0	47.9	Complied

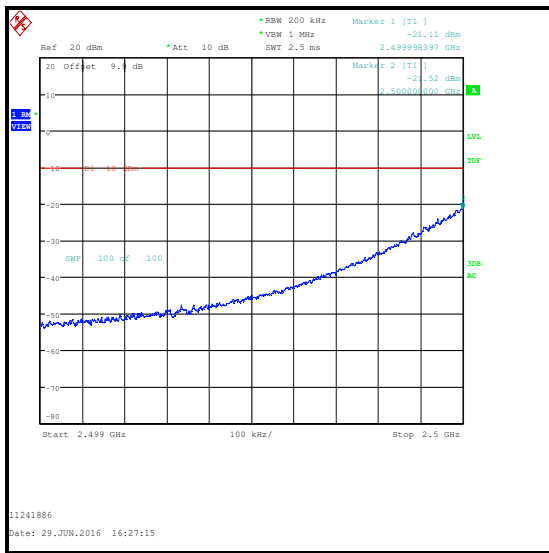

**16QAM / 1 RB 0 Offset / Lower Band Edge**

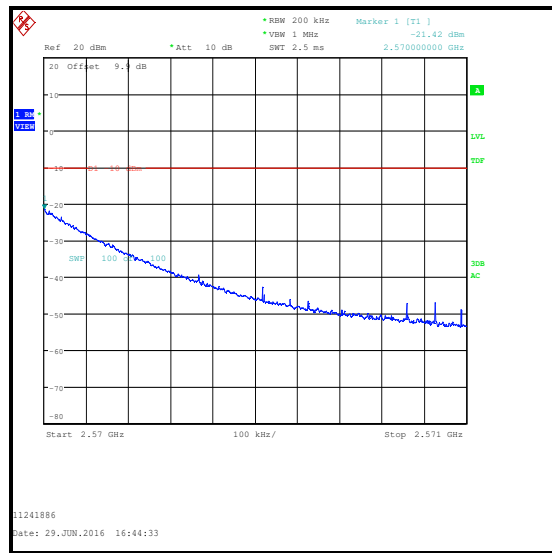

**16QAM / 1 RB 49 Offset / Upper Band Edge**

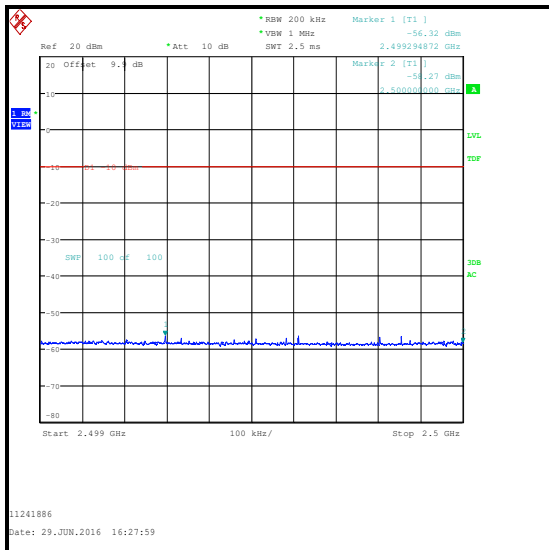

**16QAM / 1 RB 49 Offset / Lower Band Edge**

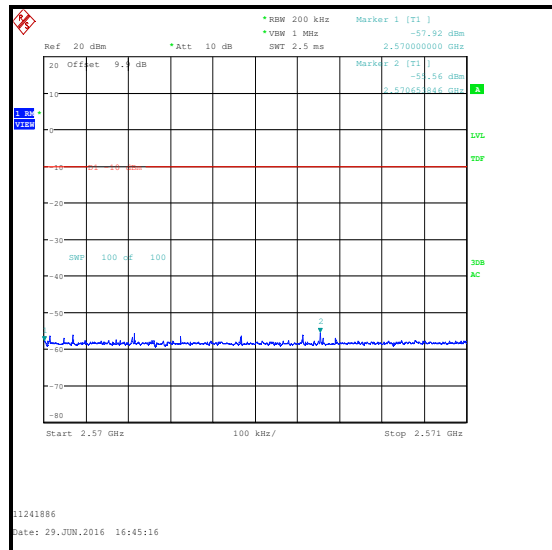

**16QAM / 1 RB 0 Offset / Upper Band Edge**

**Transmitter Radiated Emissions at Band Edges (continued)**

**Results: 15 MHz Channel Bandwidth / QPSK**

Frequency (MHz)	Resource Block(s)	Resource Block Offset	Emission Level (dBm)	Limit (dBm)	Margin (dB)	Result
2499.995	75	0	-29.5	-10.0	19.5	Complied
2500	75	0	-29.9	-10.0	19.9	Complied
2570	75	0	-29.1	-10.0	19.1	Complied
2570.002	75	0	-29.9	-10.0	19.9	Complied

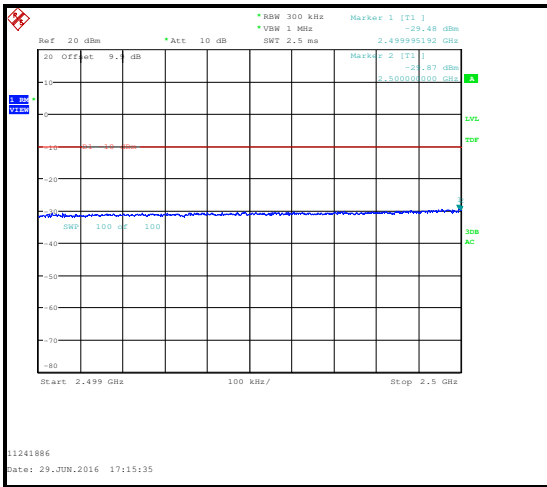

**QPSK / Lower Band Edge**

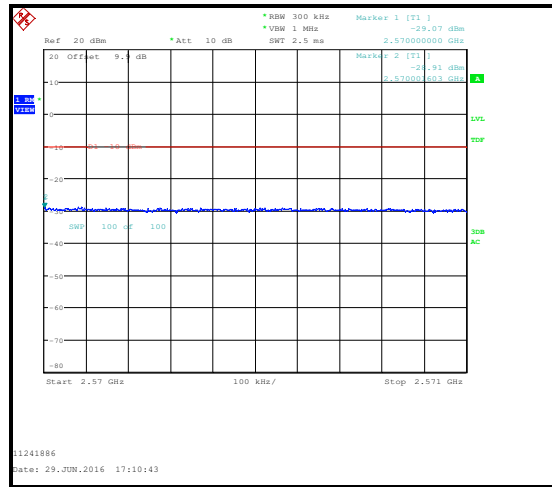

**QPSK / Upper Band Edge**

**Transmitter Radiated Emissions at Band Edges (continued)**

**Results: 15 MHz Channel Bandwidth / QPSK**

Frequency (MHz)	Resource Block(s)	Resource Block Offset	Emission Level (dBm)	Limit (dBm)	Margin (dB)	Result
2500	1	0	-20.0	-10.0	10.0	Complied
2570	1	74	-20.2	-10.0	10.2	Complied
2500	1	74	-56.7	-10.0	46.7	Complied
2570	1	0	-56.6	-10.0	46.6	Complied



**QPSK / 1 RB 0 Offset / Lower Band Edge**

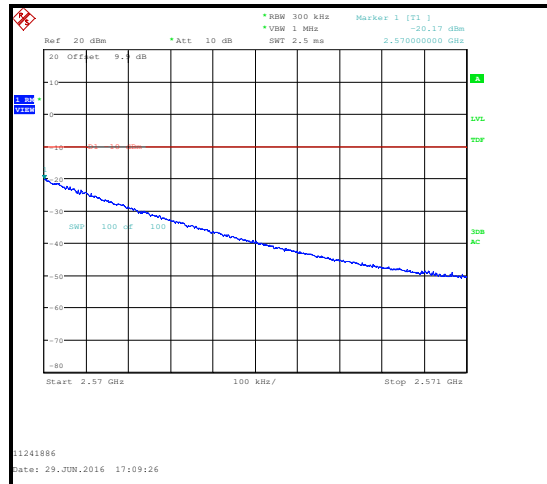

**QPSK / 1 RB 74 Offset / Upper Band Edge**

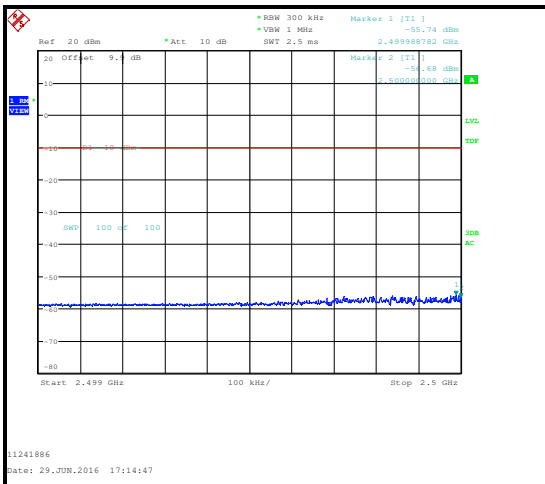

**QPSK / 1 RB 74 Offset / Lower Band Edge**

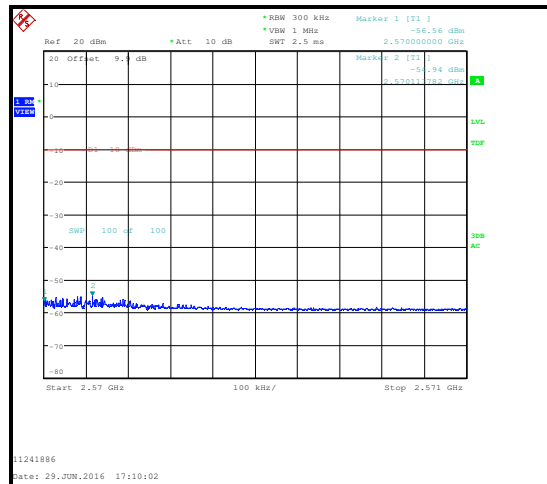

**QPSK / 1 RB 0 Offset / Upper Band Edge**

**Transmitter Radiated Emissions at Band Edges (continued)**

**Results: 15 MHz Channel Bandwidth / 16QAM**

Frequency (MHz)	Resource Block(s)	Resource Block Offset	Emission Level (dBm)	Limit (dBm)	Margin (dB)	Result
2499.973	75	0	-30.2	-10.0	20.2	Complied
2500	75	0	-30.6	-10.0	20.6	Complied
2570	75	0	-31.0	-10.0	21.0	Complied
2570.024	75	0	-30.4	-10.0	20.4	Complied

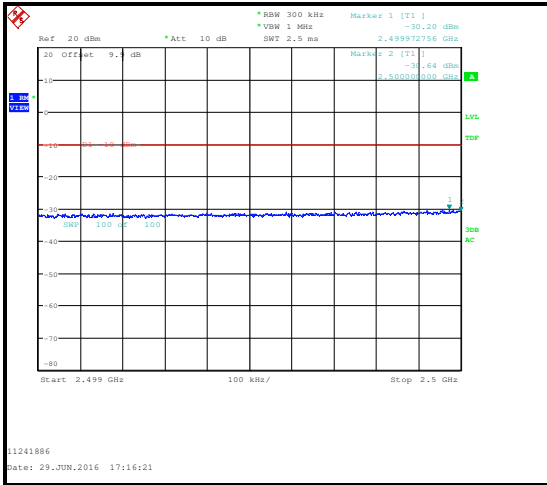

**16QAM / Lower Band Edge**

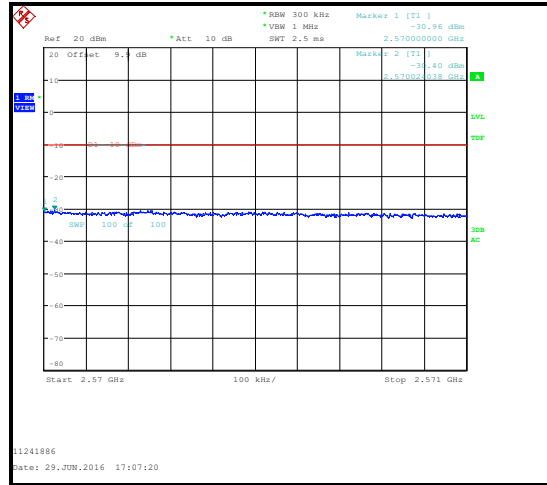

**16QAM / Upper Band Edge**

**Transmitter Radiated Emissions at Band Edges (continued)**

**Results: 15 MHz Channel Bandwidth / 16QAM**

Frequency (MHz)	Resource Block(s)	Resource Block Offset	Emission Level (dBm)	Limit (dBm)	Margin (dB)	Result
2499.997	1	0	-20.9	-10.0	10.9	Complied
2500	1	0	-21.0	-10.0	11.0	Complied
2570	1	74	-21.1	-10.0	11.1	Complied
2500	1	74	-57.5	-10.0	47.5	Complied
2570	1	0	-57.3	-10.0	47.3	Complied

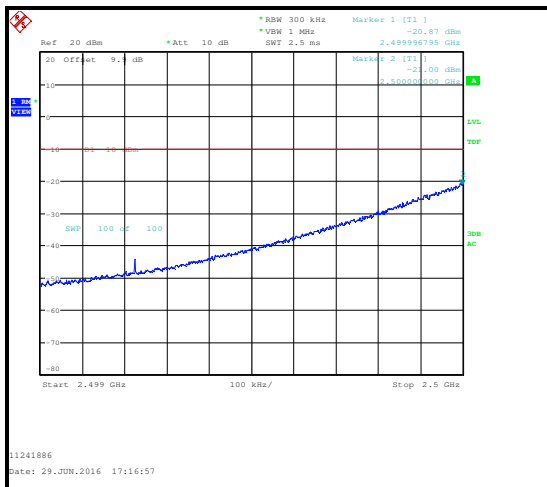

**16QAM / 1 RB 0 Offset / Lower Band Edge**

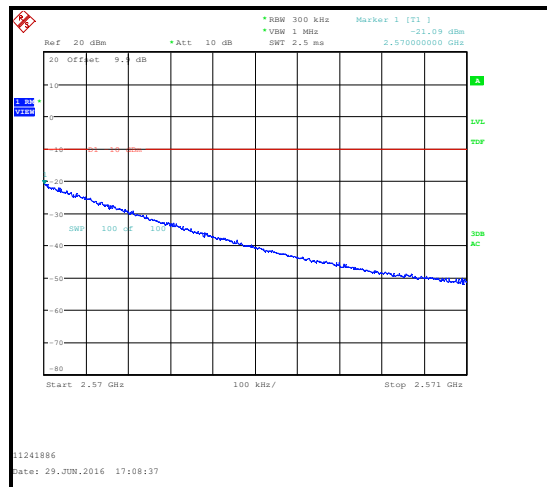

**16QAM / 1 RB 74 Offset / Upper Band Edge**

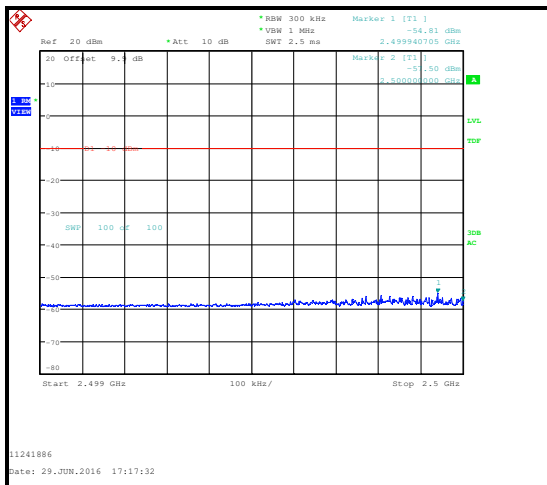

**16QAM / 1 RB 74 Offset / Lower Band Edge**

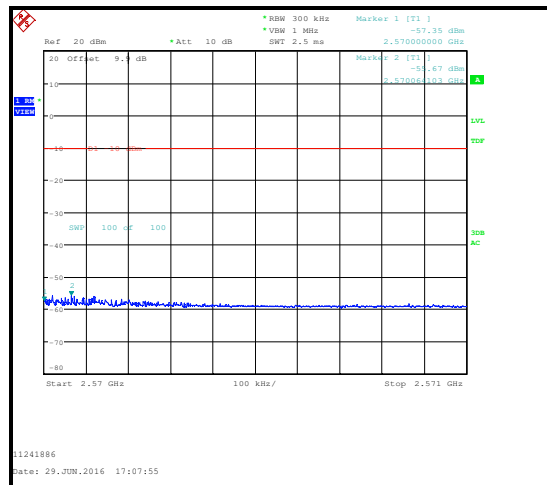

**16QAM / 1 RB 0 Offset / Upper Band Edge**

**Transmitter Radiated Emissions at Band Edges (continued)**

**Results: 20 MHz Channel Bandwidth / QPSK**

Frequency (MHz)	Resource Block(s)	Resource Block Offset	Emission Level (dBm)	Limit (dBm)	Margin (dB)	Result
2499.984	100	0	-26.7	-10.0	16.7	Complied
2500	100	0	-26.8	-10.0	16.8	Complied
2570	100	0	-26.5	-10.0	16.5	Complied
2570.008	100	0	-26.1	-10.0	16.1	Complied

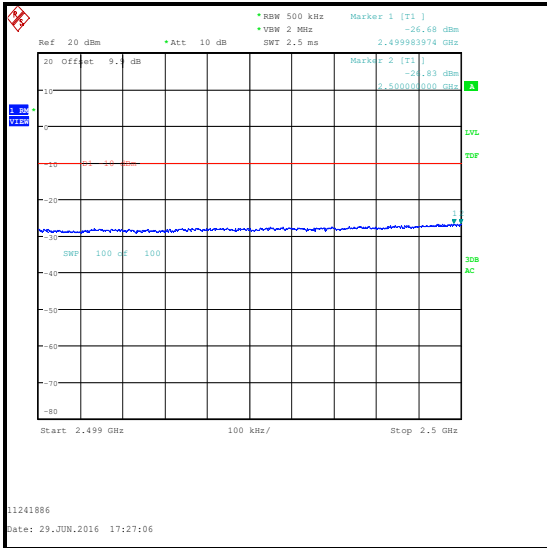

**QPSK / Lower Band Edge**

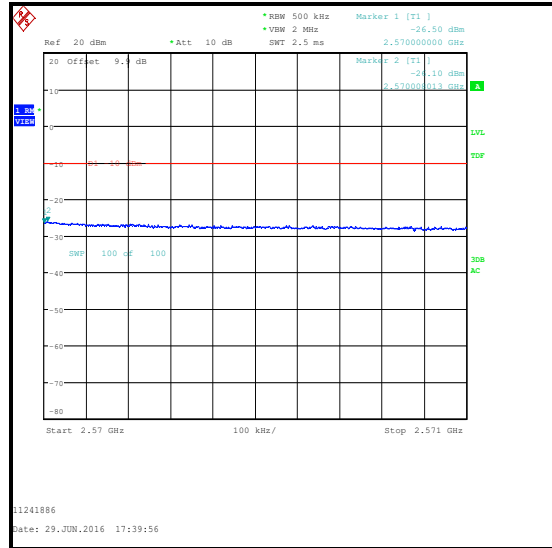

**QPSK / Upper Band Edge**

**Transmitter Radiated Emissions at Band Edges (continued)**

**Results: 20 MHz Channel Bandwidth / QPSK**

Frequency (MHz)	Resource Block(s)	Resource Block Offset	Emission Level (dBm)	Limit (dBm)	Margin (dB)	Result
2499.997	1	0	-13.9	-10.0	3.9	Complied
2500	1	0	-14.1	-10.0	4.1	Complied
2570	1	99	-13.3	-10.0	3.3	Complied
2500	1	99	-56.1	-10.0	46.1	Complied
2570	1	0	-56.0	-10.0	46.0	Complied

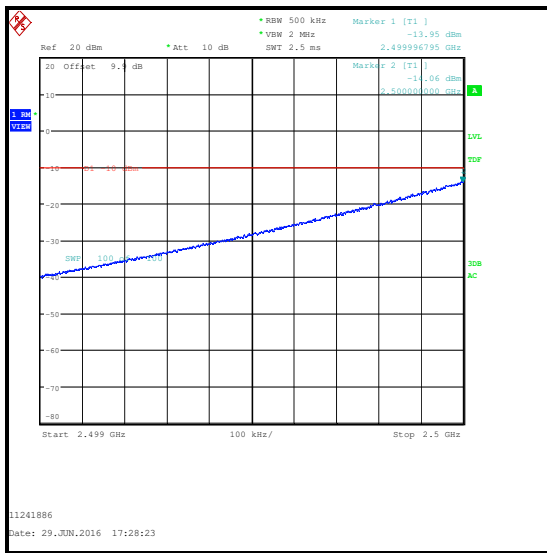

**QPSK / 1 RB 0 Offset / Lower Band Edge**

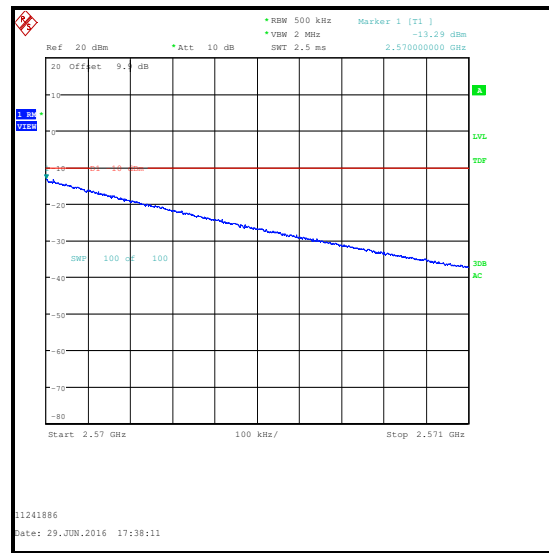

**QPSK / 1 RB 99 Offset / Upper Band Edge**

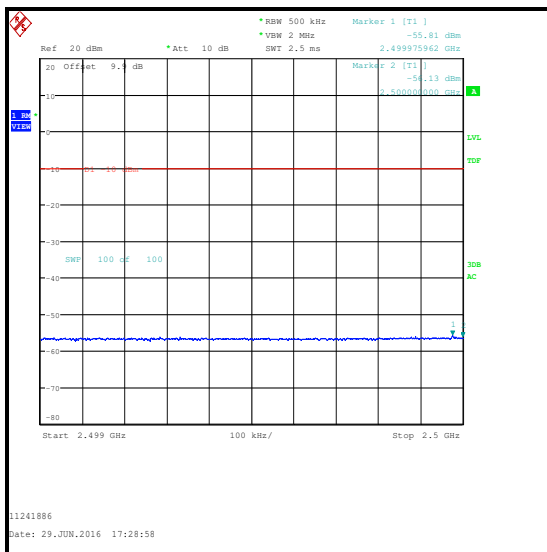

**QPSK / 1 RB 99 Offset / Lower Band Edge**

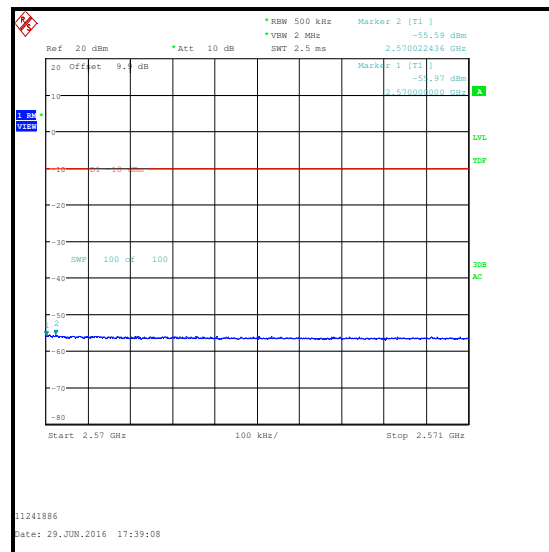

**QPSK / 1 RB 99 Offset / Upper Band Edge**

**Transmitter Radiated Emissions at Band Edges (continued)**

**Results: 20 MHz Channel Bandwidth / 16QAM**

Frequency (MHz)	Resource Block(s)	Resource Block Offset	Emission Level (dBm)	Limit (dBm)	Margin (dB)	Result
2499.992	100	0	-27.7	-10.0	17.7	Complied
2500	100	0	-27.9	-10.0	17.9	Complied
2570	100	0	-27.2	-10.0	17.2	Complied
2570.010	100	0	-27.2	-10.0	17.2	Complied

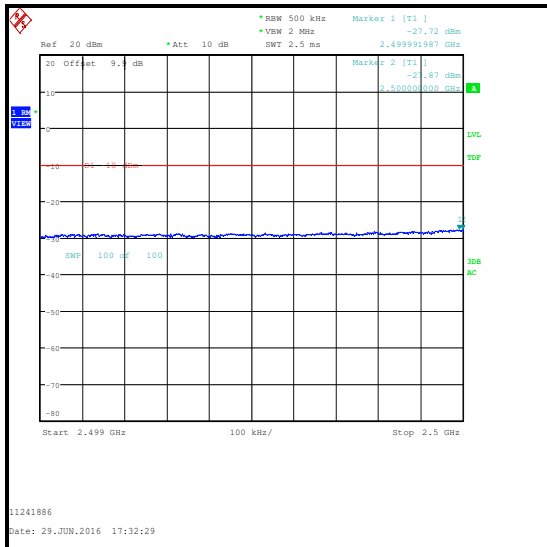

**16QAM / Lower Band Edge**

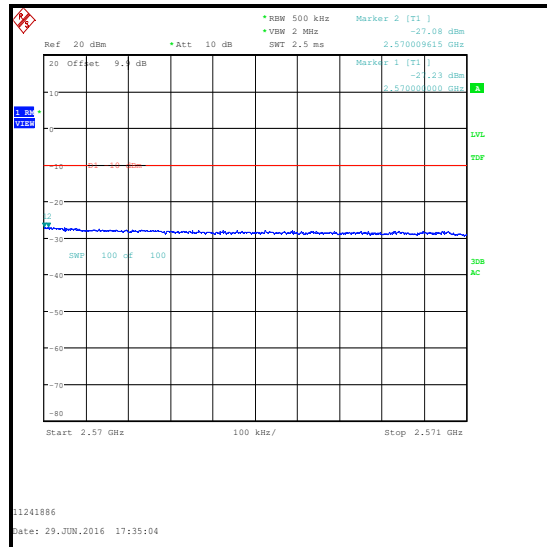

**16QAM / Upper Band Edge**

**Transmitter Radiated Emissions at Band Edges (continued)**

**Results: 20 MHz Channel Bandwidth / 16QAM**

Frequency (MHz)	Resource Block(s)	Resource Block Offset	Emission Level (dBm)	Limit (dBm)	Margin (dB)	Result
2499.990	1	0	-14.5	-10.0	4.5	Complied
2500	1	0	-14.6	-10.0	4.6	Complied
2570	1	99	-14.2	-10.0	4.2	Complied
2500	1	99	56.5	-10.0	46.5	Complied
2570	1	0	-56.1	-10.0	46.1	Complied

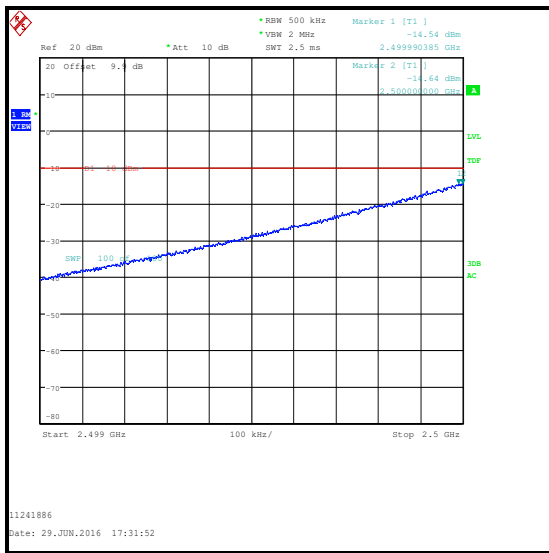

**16QAM / 1 RB 0 Offset / Lower Band Edge**



**16QAM / 1 RB 99 Offset / Upper Band Edge**

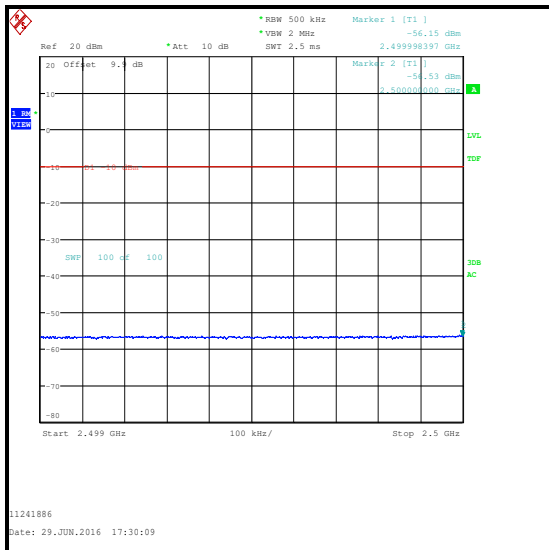

**16QAM / 1 RB 99 Offset / Lower Band Edge**

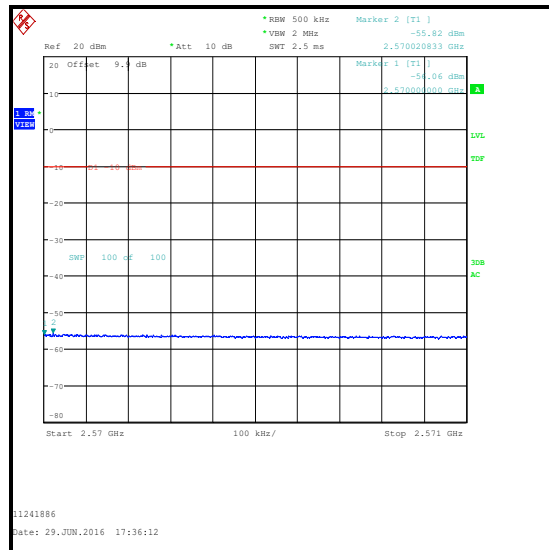

**16QAM / 1 RB 0 Offset / Upper Band Edge**

**Transmitter Radiated Emissions at Band Edges (continued)****Test Equipment Used:**

<b>Asset No.</b>	<b>Instrument</b>	<b>Manufacturer</b>	<b>Type No.</b>	<b>Serial No.</b>	<b>Date Calibration Due</b>	<b>Cal. Interval (Months)</b>
M2003	Thermohygrometer	Testo	608-H1	45046641	22 Apr 2017	12
K0017	3m RSE Chamber	Rainford EMC	N/A	N/A	17 May 2017	12
M1995	Test Receiver	Rohde & Schwarz	ESU40	100428	21 Mar 2017	12
A2893	Pre-Amplifier	Schwarzbeck	BBV 9721	9721-021	07 Apr 2017	12
A2889	Antenna	Schwarzbeck	BBHA 9120 B	BBHA 9120 B 653	07 Apr 2017	12
A2916	Attenuator	AtlanTecRF	AN18W5-10	832827#1	19 May 2017	12

**5.2.9. Transmitter Radiated Emissions at Band Edges  $\pm$  X MHz – LAT****Test Summary:**

<b>Test Engineer:</b>	Andrew Edwards	<b>Test Dates:</b>	01 July 2016 to 06 July 2016
<b>Test Sample IMEI:</b>	358640070087480		

<b>FCC Reference:</b>	Parts 2.1053 & 27.53(m)(4)
<b>Test Method Used:</b>	KDB 971168 Section 6 referencing FCC Part 27.53 & note 2 below

**Environmental Conditions:**

<b>Temperature (°C):</b>	24 to 25
<b>Relative Humidity (%):</b>	42 to 43

**Transmitter Radiated Emissions at Band Edges  $\pm$  X MHz (continued)****Note(s):**

1. Measurements were performed with the EUT transmitting with QPSK and 16QAM modulation schemes, with resource blocks settings as detailed in section 4.3 of this report.
2. Sweep time was set to auto and an RMS detector with trace averaging of 300 sweeps was used.
3. In accordance with 27.53(m)(4), the following limits were calculated:

5 MHz Channel Bandwidth		10 MHz Channel Bandwidth	
Frequency Range (MHz)	Limit (dBm)	Frequency Range (MHz)	Limit (dBm)
30 – 2494	-25	30 – 2491.103	-25
2494 – 2496	-13	2491.103 – 2496	-13
2496 – 2500	-10	2496 – 2500	-10
2570 – 2575	-10	2570 – 2575	-10
2575 – 2576	-13	2575 – 2578.897	-13
2576 – 26000	-25	2578.897 – 26000	-25

15 MHz Channel Bandwidth		20 MHz Channel Bandwidth	
Frequency Range (MHz)	Limit (dBm)	Frequency Range (MHz)	Limit (dBm)
30 – 2490.5	-25	30 – 2490.5	-25
2490.5 – 2496	-13	2490.5 – 2496	-13
2496 – 2500	-10	2496 – 2500	-10
2570 – 2575	-10	2570 – 2575	-10
2575 – 2583.432	-13	2575 – 2587.974	-13
2583.432 – 26000	-25	2587.974 – 26000	-25

4. For given channel bandwidth, the minimum value of the 99% occupied bandwidth was used to calculate the above limits. The choice of the minimum occupied bandwidth, regardless of modulation schemes, gives a worst case scenario for the applicable limit lines.
5. The plots of this section illustrate the radiated emissions at band edges, at frequencies below 2499 MHz and above 2571 MHz. Compliance in the frequency ranges 2499 – 2500 MHz and 2570 – 2571 MHz are shown in section 5.2.7 of this report.
6. In accordance with 27.53(m)(6), a narrower resolution bandwidth is allowed to be used, provided that the measured power is integrated over the full required measurement bandwidth of 1 MHz. The channel power function of the spectrum analyser was used where necessary.
7. \* Integrated level (dBm)