



TEST REPORT

Test Report No. : UL-RPT-RP11241886JD07G V5.0

Manufacturer : Apple Inc.
Model No. : A1779
FCC ID : BCG-E3086A
ISED Canada No. : IC: 579C-E3086A
Technology : WLAN
Test Standard(s) : FCC Part 15.407(h)(2)
ISED Canada RSS-247 6.3(iii) & 6.3(iv)

1. This test report shall not be reproduced in full or partial, without the written approval of UL VS LTD.
2. The results in this report apply only to the sample(s) tested.
3. The sample tested is in compliance with the above standard(s).
4. The test results in this report are traceable to the national or international standards.
5. Version 5.0 supersedes all previous versions.

Date of Issue: 03 August 2016

Checked by:

Steven White
Service Lead, Radio Laboratory

Company Signatory:

Sarah Williams
Senior Engineer, Radio Laboratory
UL VS LTD



This laboratory is accredited by UKAS.
The tests reported herein have been
performed in accordance with its terms
of accreditation.

UL VS LTD

Pavilion A, Ashwood Park, Ashwood Way, Basingstoke, Hampshire, RG23 8BG, UK
Telephone: +44 (0)1256 312000
Facsimile: +44 (0)1256 312001

This page has been left intentionally blank.

Table of Contents

1. Customer Information.....	4
2. Summary of Testing.....	5
2.1. General Information	5
2.2. Summary of Test Results	5
2.3. Methods and Procedures	6
2.4. Deviations from the Test Specification	6
3. Equipment Under Test (EUT)	7
3.1. Identification of Equipment Under Test (EUT)	7
3.2. Description of EUT	7
3.3. Modifications Incorporated in the EUT	7
3.4. Additional Information Related to Testing	8
3.5. Support Equipment	9
4. Operation and Monitoring of the EUT during Testing	10
4.1. Operating Modes	10
4.2. Configuration and Peripherals	10
5. Measurements, Examinations and Derived Results	15
5.1. General Comments	15
5.2. Test Results	16
5.2.1. Channel Closing Transmission Time and Channel Move Time	16
5.2.2. Non-Occupancy Period	20
6. Measurement Uncertainty	24
7. Report Revision History	25
Appendix 1. Radar Calibration	26
Appendix 2. Aeroflex Test Platform Approval email.....	28
Appendix 3. System Noise Floor Reference Plots.....	29
Appendix 4. Channel Loading.....	30
Appendix 5. Channel/Frequency plan	32
Appendix 6. Technical Description.....	Error! Bookmark not defined.

1. Customer Information





Company Name:	Apple Inc.
Address:	1 Infinite Loop Cupertino, CA 95014 U.S.A

2. Summary of Testing

2.1. General Information

FCC Specification Reference:	47CFR15.407
FCC Specification Title:	Code of Federal Regulations Volume 47 (Telecommunications): Part 15 Subpart E (Unlicensed National Information Infrastructure Devices) - Section 15.407
FCC Site Registration:	209735
ISED Canada Specification Reference:	RSS-247 Issue 1, May 28 2015
ISED Canada Specification Title:	Digital Transmission Systems (DTSs), Frequency Hopping Systems (FHSs) and Licence-Exempt Local Area Network (LE-LAN) Devices
ISED Canada Site Registration:	3245B-2
Location of Testing:	UL VS LTD, Unit 3 Horizon, Wade Road, Kingsland Business Park, Basingstoke, Hampshire, RG24 8AH, United Kingdom
Test Dates:	21 June 2016 to 01 August 2016

2.2. Summary of Test Results

FCC Reference (47CFR)	ISED Canada Reference	Measurement	Result
Part 15.407(h)(2)(iii)	RSS-247 6.3(iii) & 6.3(iv)	Channel Closing Transmission Time and Channel Move Time	
Part 15.407(h)(2)(iv)	RSS-247 6.3(v)	Non-Occupancy Period	
Key to Results			
 = Complied  = Did not comply			

Note(s):

- The manufacturer confirms that the information regarding the parameters of the radar waveforms is not available to the end user.
- This test is not required for a client without radar detection according to Tables 1 and 2 of KDB 905462 D02, however it was performed to show compliance with KDB 905462 D02 5.1.2 e) and KDB 905462 D03, section (b)(5) and (b)(6).

2.3. Methods and Procedures

Reference:	FCC KDB 905462 D02 U-NII DFS Compliance Procedures New Rules v02 (April 8, 2016)
Title:	Compliance Measurement Procedures for Unlicensed-National Information Infrastructure Devices Operating in the 5250-5350 MHz and 5470-5725 MHz Bands Incorporating Dynamic Frequency Selection

2.4. Deviations from the Test Specification

For the measurements contained within this test report, there were no deviations from, additions to, or exclusions from the test specification identified above.

3. Equipment Under Test (EUT)

3.1. Identification of Equipment Under Test (EUT)

Brand Name:	Apple
Model Name or Number:	A1779
Test Sample Serial Number:	C7CRQ01THCWH (<i>Conducted sample #1</i>)
Hardware Version:	REV1.0
Software Version:	iOS: 14A241z BB FW: 0.16.04
FCC ID:	BCG-E3086A
ISED Canada Certification No.:	IC: 579C-E3086A

Brand Name:	Apple
Model Name or Number:	A1779
Test Sample Serial Number:	C7CRR02FHCPX (<i>Conducted sample #2</i>)
Hardware Version:	REV1.0
Software Version:	iOS: 14A241z BB FW: 0.16.04
FCC ID:	BCG-E3086A
ISED Canada Certification No.:	IC: 579C-E3086A

3.2. Description of EUT

The Equipment Under Test was a mobile phone with GSM/GPRS/EGPRS/UMTS/LTE/TD-SCDMA and CDMA technologies. It also supports IEEE 802.11a/b/g/n/ac, Bluetooth®, GPS and NFC. The rechargeable battery is not user accessible.

3.3. Modifications Incorporated in the EUT

No modifications were applied to the EUT during testing.

3.4. Additional Information Related to Testing

Technology Tested:	WLAN (IEEE 802.11b,g,n), Digital Transmission System	
Type of Unit:	Transceiver	
Modulation Type:	DBPSK, DQPSK, BPSK, QPSK, 16QAM & 64QAM	
Data Rate/Mode:	802.11ac VHT80	MCS0
Transmit / Receive Frequency Range:	5250 to 5350 MHz 5470 to 5850 MHz	
Transmit / Receive Channels Tested at 80 MHz Bandwidth setting:	Channel ID	Channel Centre Frequency (MHz)
	58	5320
Transmit / Receive Channels Tested at 20 MHz Bandwidth setting:	Channel ID	Channel Centre Frequency (MHz)
	100	5500

3.5. Support Equipment

The following support equipment was used to exercise the EUT during testing:

Description:	Wireless Dual Band Router (DFS Master)
Brand Name:	Cisco
Model Name or Number:	AIR-CAP3702E-A-K9 V04
FCC ID:	LDK102087
ISED Canada Certification No:	IC: 2461B-102087
Serial Number:	FJC1938F3G6

Description:	Laptop PC
Brand Name:	Dell
Model Name or Number:	Latitude E5410
Serial Number:	DQC78L1

Brand Name:	Apple
Description:	Video Streaming Box
Model Name or Number:	A1625 / Apple TV
Serial Number:	C07PL023GN7T

Brand Name:	Logik
Description:	Television
Model Name or Number:	L22FE12A
Serial Number:	1309020661

4. Operation and Monitoring of the EUT during Testing

4.1. Operating Modes

The EUT was tested in the following operating modes, unless otherwise stated:

- Operating on the channel selected by the Master device in either U-NII Band 2a or U-NII Band 2c.
- The Master device controls the channel bandwidth and modulation of the EUT in set-up 1 shown on the following page . The Master device was set to 802.11ac / MCS0 with 80 MHz channel bandwidth.
- KDB 905462 D02 *U-NII DFS Compliance Procedures* states in Table 2 the EUT should be tested at maximum channel bandwidth (80 MHz for 802.11ac mode). This was performed on an 80 MHz channel bandwidth for set-up 1. Set-up 2 used the AirPlay protocol which automatically selects the channel bandwidth for the movie being streamed direct to the Apple TV. Therefore testing was performed during the auto-selection of a 20 MHz channel, the only bandwidth which yielded the required channel loading using an HD movie.
- For the required channel loading of >17% in KDB 905642 D02 7.7(c), a data transfer was performed between a test PC and the EUT. See Appendix 4 *Channel Loading* for further details.

4.2. Configuration and Peripherals

The EUT was tested in the following configuration(s):

- The EUT is a DFS Client without Radar Detection capability. It was tested in combination with an FCC/ISED Canada certified Cisco DFS enabled router being used as the Master (see *Section 3.5: Support Equipment* for further details). A Radar Type 0 was injected to the Master to test the Client's Channel Move Time and Channel Closing Transmission Time after receiving the channel shutdown command from the Master.
- All measurements were made using a conducted link. The EUT has two external antenna ports fitted for test purposes. 'Port 1' was tested. System losses for the interconnecting hardware were measured and taken into consideration.
- The Radar test platform used was the Aeroflex DFS Radar 110105 Simulator and Analyser which has been verified and accepted by Andrew Leimer of the FCC/NTIA on the 23rd of September 2011. Refer to Appendix 2 of this Test Report for the original confirmation email.
- The DFS detection threshold of -61.0 dBm (-62 dBm + 1 dB + 0 dBi) was used at the Master device antenna port. Note this is not dependent on the EUT EIRP, Spectral Density or EUT antenna gain, only the antenna gain of the Master device, as the EUT does not have radar detection.
- The Master device used for test was set to 17 dBm / 50 mW with TPC enabled.
- Plots and data were captured using a Rohde and Schwarz ESU Test Receiver or FSV Signal Analyser. The number of data points was increased to maximum and the trace data exported so it could be analysed in far greater detail than available on the built-in display.
- The Channel Move Time was the time taken from the end of the radar waveform to the time the Client (EUT) ceased transmissions. The Channel Closing Transmission Time was calculated to the nearest sample from any additional pulses occurring >200 ms after the end of the radar.
- The EUT was also tested in a second setup where it was directly exchanging data with another Client associated with the same network using Apple's AirPlay protocol. Both setups are explained with diagrams in the following section.

Setup diagram for test of DFS Client without Radar Detection: Setup 1

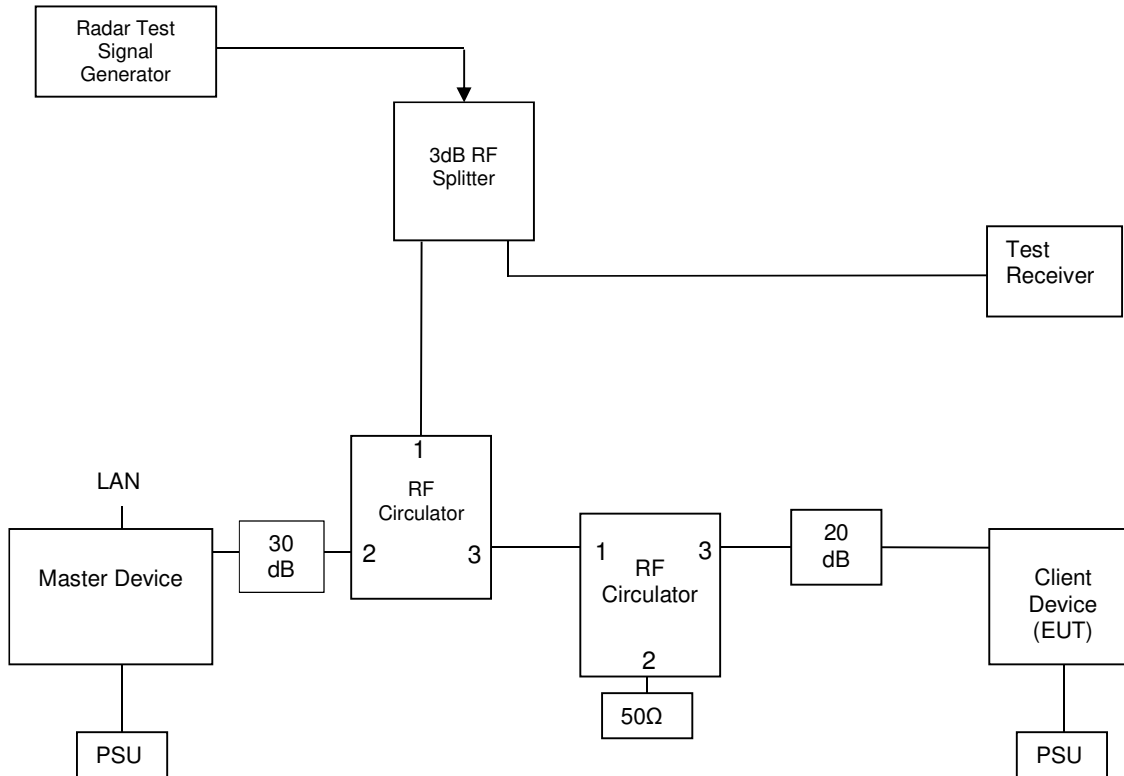

Rationale

The setup shown above ensures the waveforms indicated on the spectrum analyser are in order of magnitude. The circulators have typically 18 dB attenuation in the reverse direction. The left-hand circulator directs the radar towards the Master, ensuring there is not an overly large radar pulse into the Client (EUT) even though there is the same attenuation between the Client and the radar generator. The radar signal should be approximately 26 dB smaller at the Client antenna port than at the Master. The right-hand circulator is to give the same path loss between Master and Client in both directions of the 802.11 communications link.

The radar signal is most predominant on the spectrum analyser, coming straight through a 3 dB splitter. The Client is 2nd largest, being attenuated by the 20 dB, and the (typically 18 dB) isolation from the directional splitter. The smallest signal is the Master, being attenuated by 30 dB from the attenuator and approximately 18 dB from the left-hand circulator and 18 dB across the splitter.

The RF path from the radar generator to the DFS Master crosses no isolated ports of any splitters or circulators and any change of impedance in load between calibration and test is isolated from any circulators by 50 Ω attenuators which further minimises mismatch. This setup therefore meets the requirements of KDB 905462 D02 clause 7.2 points (1) and (2) whilst providing greater radar generator amplitude headroom and lower radar signal at the Client.

Setup diagram for test of DFS Client without Radar Detection: Setup 2

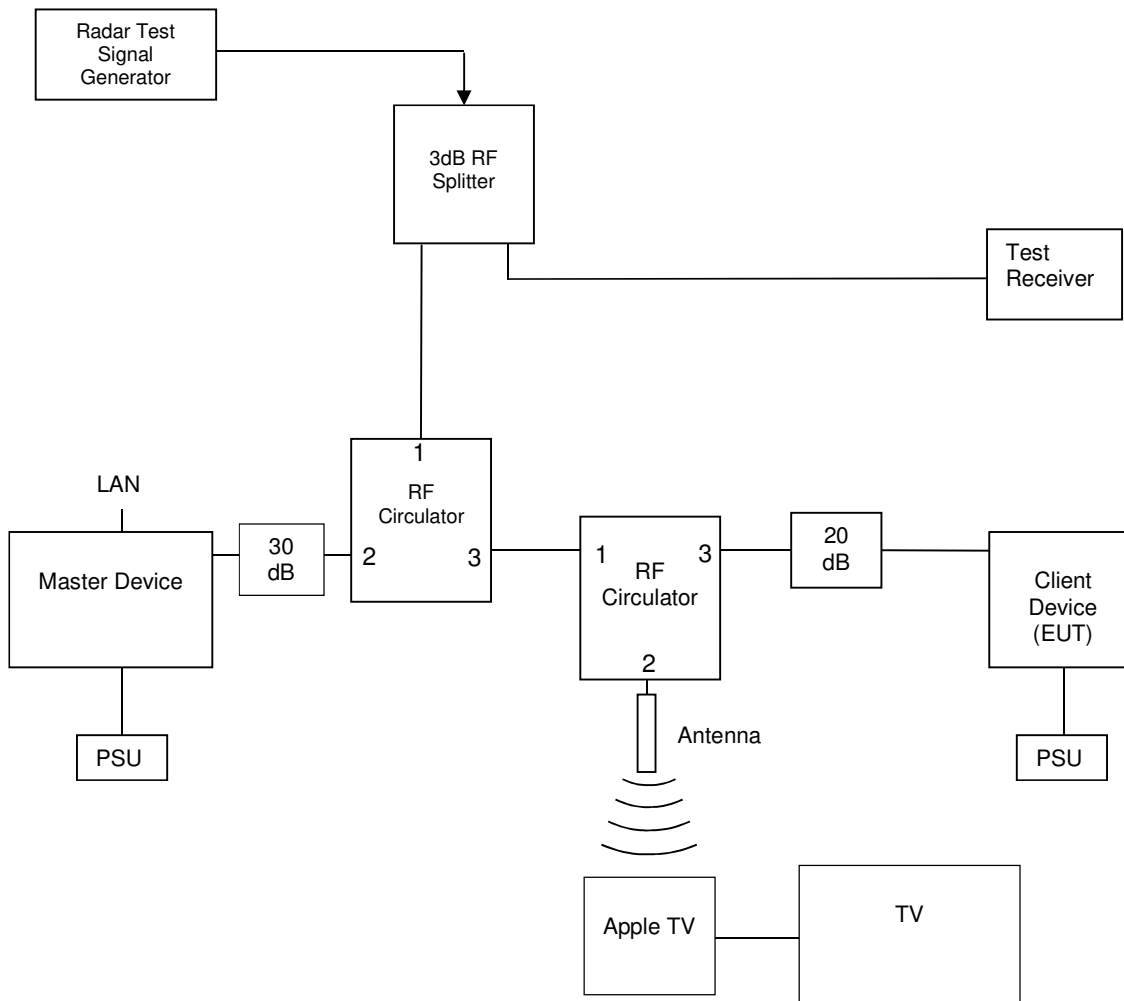

Rationale

This setup is exactly the same as the previous one, except the EUT is also communicating with the Apple TV on the same network. A movie was streamed directly to the Apple TV from the Client, using Apple’s AirPlay technology. The Apple TV was placed close enough to the antenna to make sure that the link between EUT and the Apple TV is stronger than the link between the EUT and the Master device. This was also achieved by controlling the attenuation in the network. The transmit duty cycle of the EUT could not be directly controlled, but a high-quality 1080p movie was used to maximize the transmission duty cycle and create the worst-case scenario.

Applicability of DFS requirements prior to use of a channel

Requirement	Operational Mode		
	Master	Client Without Radar Detection	Client With Radar Detection
<i>Non-Occupancy Period</i>	Yes	Not required	Yes
<i>DFS Detection Threshold</i>	Yes	Not required	Yes
<i>Channel Availability Check Time</i>	Yes	Not required	Not required
<i>Uniform Spreading</i>	Yes	Not required	Yes

Applicability of DFS requirements during normal operation

Requirement	Operational Mode	
	Master Device or Client with Radar Detection	Client Without Radar Detection
<i>DFS Detection Threshold</i>	Yes	Not required
<i>Channel Closing Transmission Time</i>	Yes	Yes
<i>Channel Move Time</i>	Yes	Yes
<i>U-NII Detection Bandwidth</i>	Yes	Not required

Additional requirements for devices with multiple bandwidth modes	Master Device or Client with Radar Detection	Client Without Radar Detection
<i>U-NII Detection Bandwidth and Statistical Performance Check</i>	All BW modes must be tested	Not required
<i>Channel Move Time and Channel Closing Transmission Time</i>	Test using widest BW mode available	Test using the widest BW mode available for the link
<i>All other tests</i>	Any single BW mode	Not required

Note: Frequencies selected for statistical performance check (Section 7.8.4) should include several frequencies within the radar detection bandwidth and frequencies near the edge of the radar detection bandwidth. For 802.11 devices it is suggested to select frequencies in each of the bonded 20 MHz channels and the channel center frequency.

Interference Threshold values, Master or Client incorporating In-Service Monitoring

Maximum Transmit Power	Value (see notes)
EIRP \geq 200 milliwatt	-64 dBm
EIRP < 200 milliwatt and power spectral density < 10 dBm/MHz	-62 dBm
EIRP < 200 milliwatt that do not meet the power spectral density requirement	-64 dBm

Note 1: This is the level at the input of the receiver assuming a 0 dBi receive antenna

Note 2: Throughout these test procedures an additional 1dB has been added to the amplitude of the test transmission waveforms to account for variations in measurement equipment. This will ensure that the test signal is at or above the detection threshold level to trigger a DFS response.

Note 3: EIRP is based on the highest antenna gain. For MIMO devices refer to KDB Publication 662911 D01.

DFS Response requirement values

Parameter	Value
<i>Non-occupancy period</i>	Minimum 30 minutes
<i>Channel Availability Check Time</i>	60 seconds
<i>Channel Move Time</i>	10 seconds See Note 1.
<i>Channel Closing Transmission Time</i>	200 milliseconds + an aggregate of 60 milliseconds over remaining 10 second period. See Notes 1 and 2.
<i>U-NII Detection Bandwidth</i>	Minimum 100% of the U-NII 99% transmission power bandwidth. See Note 3.

Note 1: *Channel Move Time* and the *Channel Closing Transmission Time* should be performed with Radar Type 0. The measurement timing begins at the end of the Radar Type 0 burst.

Note 2: The *Channel Closing Transmission Time* is comprised of 200 milliseconds starting at the beginning of the *Channel Move Time* plus any additional intermittent control signals required to facilitate a *Channel* move (an aggregate of 60 milliseconds) during the remainder of the 10 second period. The aggregate duration of control signals will not count quiet periods in between transmissions.

Note 3: During the *U-NII Detection Bandwidth* detection test, radar type 0 should be used. For each frequency step the minimum percentage of detection is 90 percent. Measurements are performed with no data traffic.

Short Pulse Radar Test Waveforms

Radar Type	Pulse Width (Microseconds)	PRI (Microseconds)	Pulses	Minimum Percentage of Successful Detection	Minimum Trials
0	1	1428	18	See Note 1	See Note 1

Note 1: Short Pulse Radar Type 0 should be used for the detection bandwidth test, channel move time, and channel closing time tests.

5. Measurements, Examinations and Derived Results

5.1. General Comments

Measurement uncertainties are evaluated in accordance with current best practice. Our reported expanded uncertainties are based on standard uncertainties, which are multiplied by an appropriate coverage factor to provide a statistical confidence level of approximately 95%. Please refer to *Section 6 Measurement Uncertainty* for details.

In accordance with UKAS requirements all the measurement equipment is on a calibration schedule. All equipment was within the calibration period on the date of testing.

5.2. Test Results

5.2.1. Channel Closing Transmission Time and Channel Move Time

Test Summary:

Test Engineer:	Philip Harrison	Test Dates:	21 June 2016 to 29 June 2016
Test Sample Serial Numbers:	C7CRQ01THCWH & C7CRR02FHCPX		

FCC Reference:	Part 15.407(h)(2)(iii)
ISED Canada Reference:	RSS-247 6.3(iii) & 6.3(iv)
Test Method Used:	KDB 905462 D02 Section 7.8.3

Environmental Conditions:

Temperature (°C):	22 to 25
Relative Humidity (%):	39 to 41

Note(s):

1. The channel move time is the time taken from the end of the radar burst to the ceasing of transmissions of the EUT and compared to the 10000 ms limit.
2. The Total Aggregate Channel Closing Transmission Time shown in the table below was measured from 200 ms after the end of the radar burst and compared to the 60 ms limit.
3. The smaller transmissions seen in the plot that are not included in the move time come from the Master device and not from the Client, these transmissions can be ignored for the below results.
4. The path losses from the EUT to the spectrum analyser were incorporated in the measurements.
5. All transmissions after the reported channel move time were from the router or Apple TV.

Results: Setup 1

Channel Frequency (MHz)	Channel Move Time (ms)	Total Aggregate Channel Closing Time after first 200 ms (ms)	Limit (ms)	Margin (ms)	Result
5320	42.4	-	10000	9958.6	Complied
5320	-	0	60	60	Complied

Results: Setup 2

Channel Frequency (MHz)	Channel Move Time (ms)	Total Aggregate Channel Closing Time after first 200 ms (ms)	Limit (ms)	Margin (ms)	Result
5500	200.6	-	10000	9799.4	Complied
5500	-	0.9	60	59.1	Complied

Radar burst type 0 was detected and channel move occurred.

Channel Closing Transmission Time and Channel Move Time (continued)

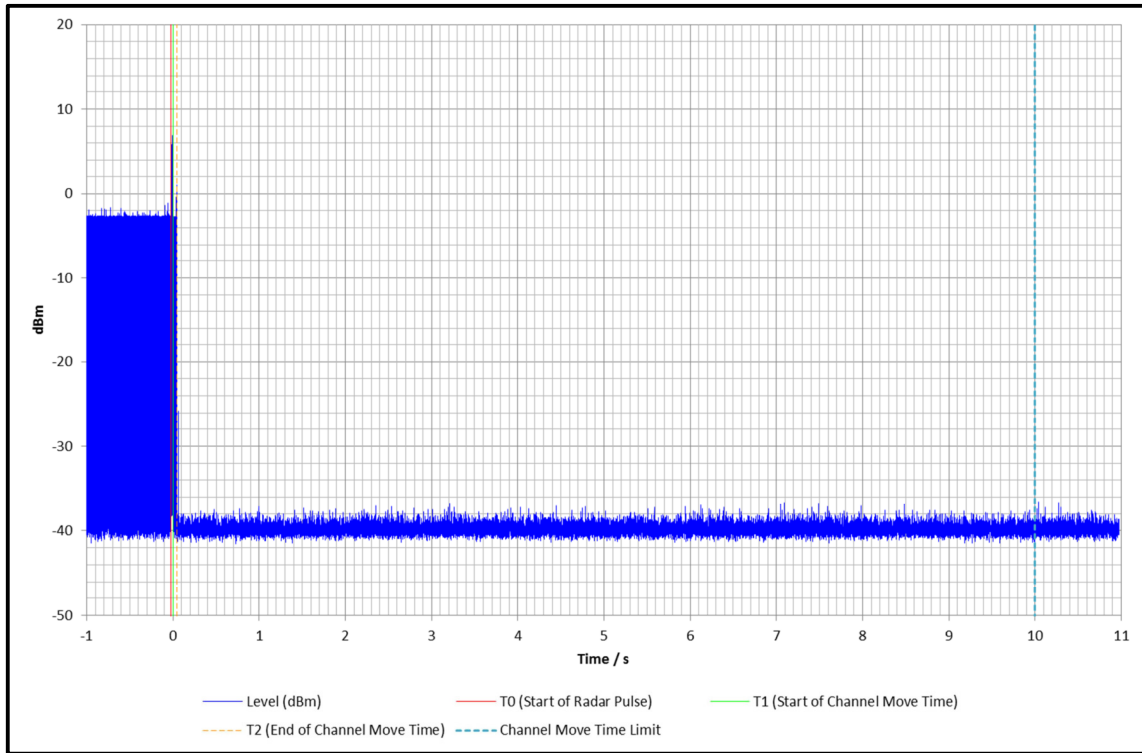

Setup 1 Channel Move Time 5320 MHz – Short Radar (Type 0) – Full 10 seconds

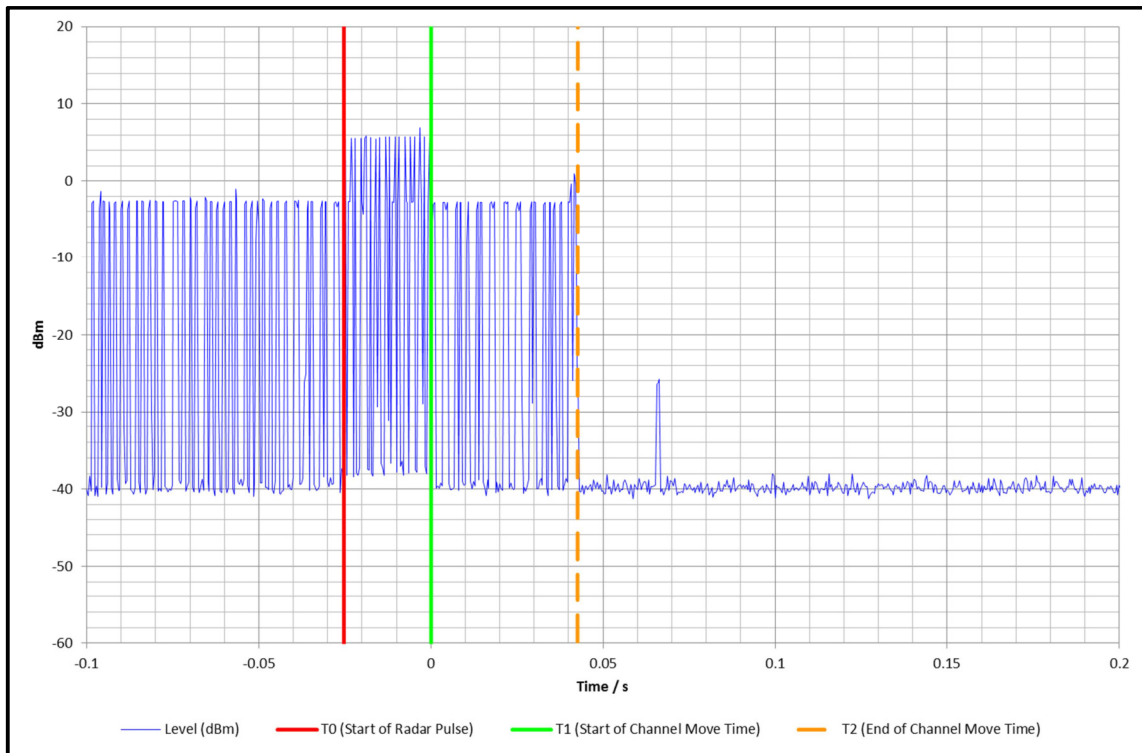

Setup 1 Channel Move Time 5320 MHz – Short Radar (Type 0) – Zoomed Plot

Channel Closing Transmission Time and Channel Move Time (continued)

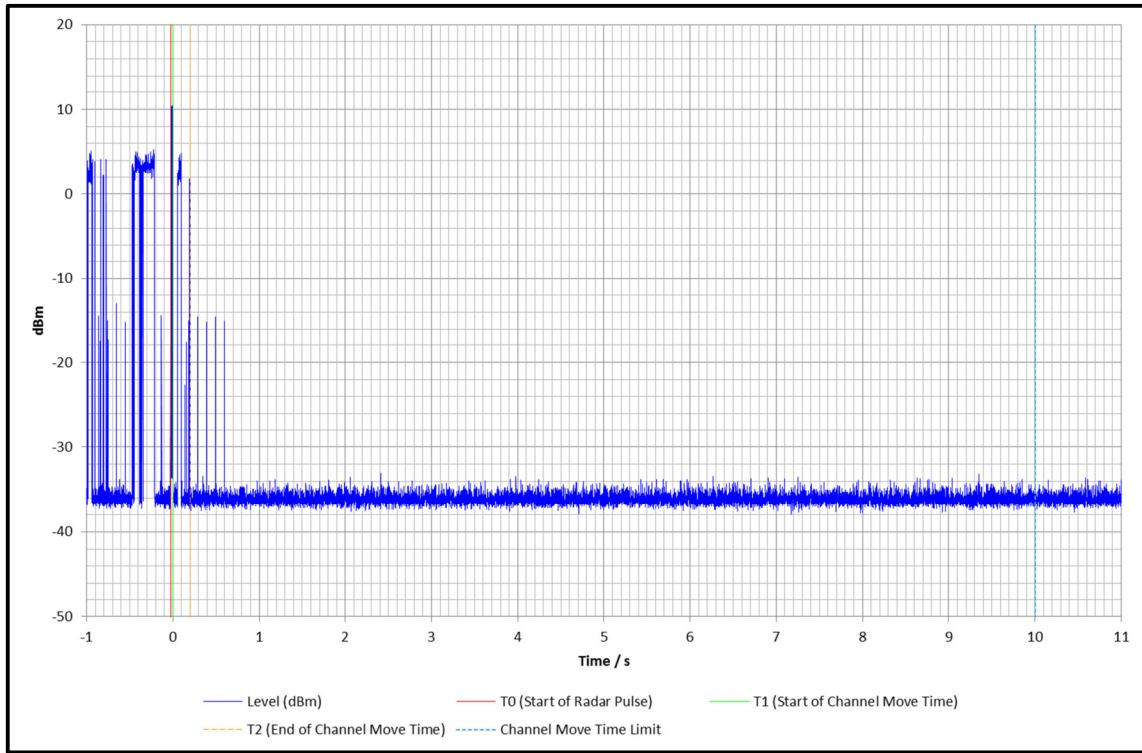

Setup 2 Channel Move Time 5500 MHz – Short Radar (Type 0) – Full 10 seconds

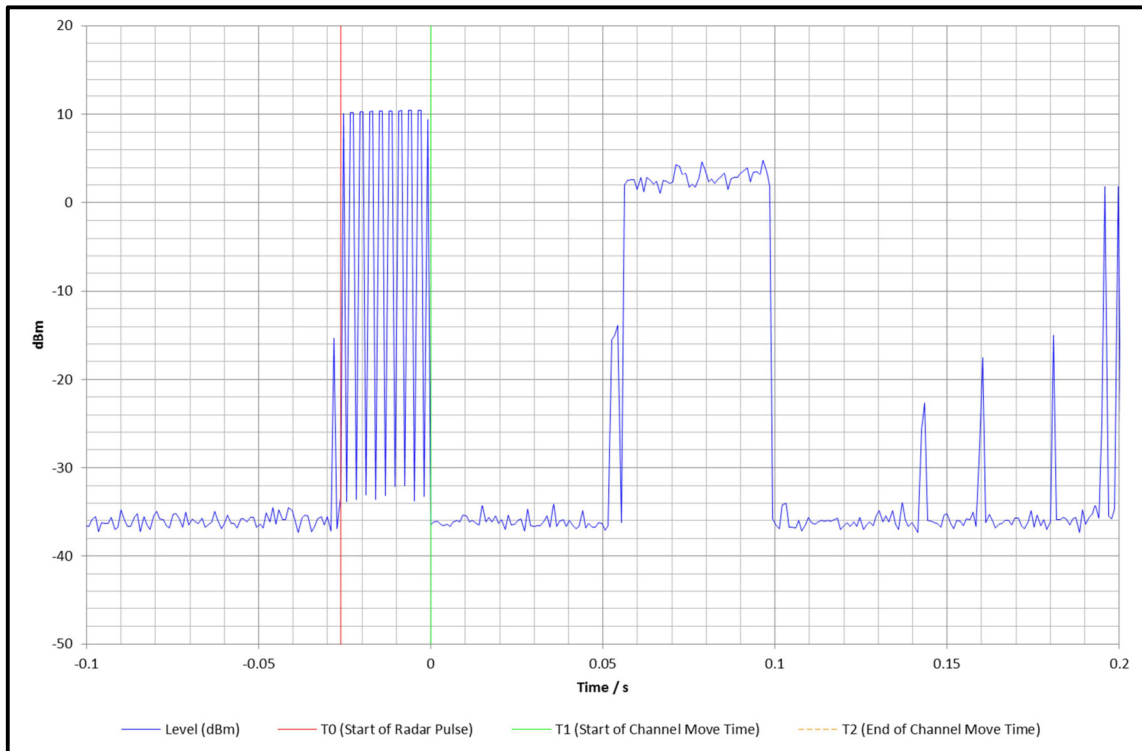

Setup 2 Channel Move Time 5500 MHz – Short Radar (Type 0) – Zoomed Plot

Channel Closing Transmission Time and Channel Move Time (continued)**Test Equipment Used:**

Asset No.	Instrument	Manufacturer	Type No.	Serial No.	Date Calibration Due	Cal. Interval (Months)
M1631	DFS Test System	Aeroflex	PXI 3000	300110/291	09 Jul 2017	24
M1630	Test Receiver	Rohde & Schwarz	ESU40	100233	17 Feb 2017	12
M1883	Signal Analyser	Rohde & Schwarz	FSV-30	103084	09 May 2017	12
A1535	Step Attenuator	Hewlett Packard	8495B/8494B	00007	Calibrated before use	-
A1536	Step Attenuator	Hewlett Packard	8495B/8494B	3308A30801 / 3308A19649	Calibrated Before Use	-
A2181	Coaxial Circulator 4 – 18 GHz	Atlantec	ACC-20130-SF-SF-SF	120409229	Calibrated Before Use	-
A2183	Coaxial Circulator 4 – 18 GHz	Atlantec	ACC-20130-SF-SF-SF	120409232	Calibrated Before Use	-
A2119	Power Splitter	Mini-Circuits	ZN2PD-63-S+	SUU12701203	Calibrated Before Use	-
A162	50Ω Termination	Narda	3768NM	5204	Calibrated Before Use	-
A2491	50Ω Termination	Narda	TA06W5-M	121813#2	Calibrated Before Use	-
A2494	50Ω Termination	Narda	TA06W5-F	082013#2	Calibrated Before Use	-
M2001	Thermohygrometer	Testo	608-H1	45041824	02 Apr 2017	12

5.2.2. Non-Occupancy Period**Test Summary:**

Test Engineer:	Philip Harrison	Test Date:	01 August 2016
Test Sample Serial Number:	C7CRR02FHCPX		

FCC Reference:	Part 15.407(h)(iv)
ISED Canada Reference:	RSS-247 6.3(iii) & 6.3(iv)
Test Method Used:	KDB 905462 D02 Section 7.8.3

Environmental Conditions:

Temperature (°C):	22
Relative Humidity (%):	63

Notes:

1. This test is not required for a client without radar detection according to Tables 1 and 2 of KDB 905462 D02, however it was performed to show compliance with KDB 905462 D02 5.1.2 e) and KDB 905462 D03, section (b)(5) and (b)(6). Therefore no specified bandwidth requirement is given and so was performed using an 80 MHz channel bandwidth; as used for *Channel Closing Transmission Time and Channel Move Time*.
2. Radar burst type 0 was detected and the channel was vacated for >1800 seconds. Since the client has no radar detection and is therefore not performing an 'intelligent' blacklisting of the channel, the device was shown not to transmit for greater than 30 minutes after its own shutdown time, not the shutdown of the DFS master or the second client in the peer-to-peer set-up.
3. The noise floor remains below the -27 dBm/MHz spurious limit for the 30 minute (1800 second) non-occupancy period, except where the other devices are still transmitting and are yet to have shutdown. Therefore the EUT is deemed to comply.