

Transmitter Maximum Conducted Output Power (5.725-5.85 GHz band) (continued)

Results: 802.11ac / 80 MHz / BPSK / MCS0x1 / MIMO

Channel	Frequency (MHz)	Port 1			Port 2		
		Conducted Peak Power (dBm)	Duty Cycle Correction (dB)	Corrected Conducted Peak Power (dBm)	Conducted Peak Power (dBm)	Duty Cycle Correction (dB)	Corrected Conducted Peak Power (dBm)
Single	5775	17.9	0.2	18.1	16.5	0.2	16.7

Channel	Frequency (MHz)	Corrected Conducted Peak Power Port 1 (dBm)	Corrected Conducted Peak Power Port 2 (dBm)	Combined Conducted Power (dBm)	Limit (dBm)	Margin (dB)	Result
Single	5775	18.1	16.7	20.5	30.0	9.5	Complied

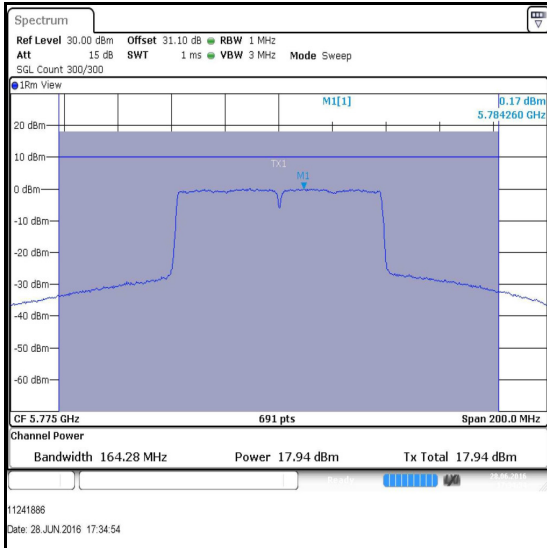

Single Channel / Port 1

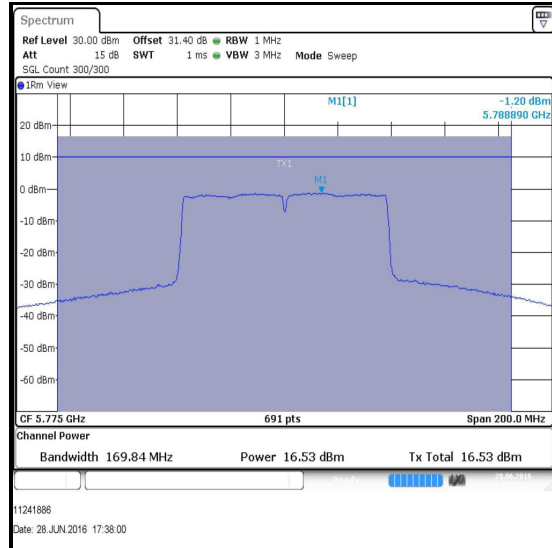

Single Channel / Port 2

Transmitter Maximum Conducted Output Power (continued)**Test Equipment Used:**

Asset No.	Instrument	Manufacturer	Type No.	Serial No.	Date Calibration Due	Cal. Interval (Months)
M1659	Thermohygrometer	JM Handlungspunkt	30.5015.13	None stated	02 Apr 2017	12
M1835	Signal Analyser	Rohde & Schwarz	FSV30	103050	27 Feb 2017	12
M1867	Attenuator	Huber + Suhner AG	6820.17.B	07101	Calibrated before use	-
A2847	Attenuator	Radiall	R411.820.121	24671450	Calibrated before use	-
A2345	Attenuator	Macom	2082-6043-20	None stated	Calibrated before use	-
A2952	RF Switch	Pickering Interfaces	64-102-002 & 40-881-001	XZ361012 & X361507	Calibrated before use	-
S0538	DC Power Supply	TTi	PL154	250135	Calibrated before use	-
M1818	Multimeter	Fluke	79III	71811580	27 Apr 2017	12
M1252	Signal Generator	Hewlett Packard	83640A	3119A00489	26 Oct 2017	24

5.2.5. Transmitter Maximum Power Spectral Density**Test Summary:**

Test Engineer:	Georgios Vrezas	Test Dates:	28 June 2016 & 21 July 2016
Test Sample IMEI:	358640070098109		

FCC Reference:	Part 15.407(a)(1)(iv)
Test Method Used:	KDB 789033 D02 Section II.F. referencing II.E.2.b) and II.E.2.d)

Environmental Conditions:

Temperature (°C):	24 to 25
Relative Humidity (%):	45 to 46

Note(s):

- Transmitter Maximum Power Spectral Density tests in all bands were performed using a signal analyser in accordance with KDB 789033 II. F referencing II.E.2.b) Method SA-1 and II.E.2.d) Method SA-2.
- The customer declared the following data rates to be used for all measurements as:
 - 802.11a – BPSK / 6 Mbps / Port 1
 - 802.11n HT20 SISO – BPSK / 6.5 Mbps / MCS0 / Port 1
 - 802.11n HT40 SISO – BPSK / 13.5 Mbps / MCS0 / Port 1
 - 802.11ac VHT80 SISO – BPSK / 29.3 Mbps / MCS0 / Port 1
 - 802.11n HT20 MIMO – BPSK / 6.5 Mbps / MCS0
 - 802.11n HT40 MIMO – BPSK / 13.5 Mbps / MCS0
 - 802.11ac VHT80 MIMO – BPSK / 29.3 Mbps / MCS0x1

Measurements were then performed in these modes on all relevant channels in all operating bands.

- For data rates where the EUT was transmitting at <98% duty cycle, the calculated duty cycle in section 5.2.3 was added to the measured maximum power spectral density in order to compute the average maximum power spectral density during the actual transmission time.
- PSD was measured on both ports and then combined using the measure and sum spectral maxima across the outputs technique, stated in FCC KDB 662911 D01 Section E)2)b).
- For all operating modes in each supported operating band, the EUT has a directional antenna gain of <6 dBi. Refer to section 5.2.4 of this test report for directional antenna gain calculations.
- The signal analyser was connected to the RF port on the EUT using an RF switch, suitable attenuation and RF cables. An RF level offset was entered on the signal analyser to compensate for the loss of the switch, attenuators and RF cables.
- As the power spectral density test uses the same test method as the output power test, before the power is integrated across the 26 dB bandwidth, the conducted power spectral density plots are located in the conducted output power section 5.2.4 of this test report. The peak spectral density was measured by placing a marker on the peak of the signal and the results entered in the tables below.

Transmitter Maximum Power Spectral Density (continued)

Test setup:

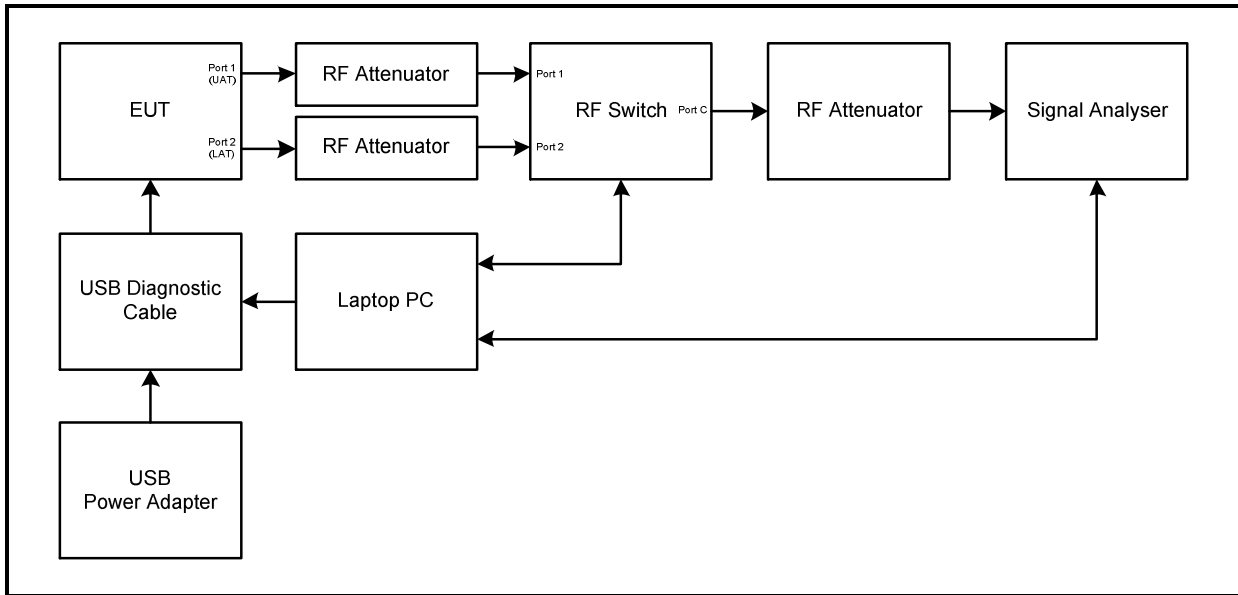

Transmitter Maximum Power Spectral Density (5.15-5.25 GHz band) (continued)**Results: 802.11a / 20 MHz / BPSK / 6 Mbps**

Channel	Frequency (MHz)	PPSD (dBm /MHz)	Limit (dBm /MHz)	Margin (dB)	Result
Bottom	5180	5.5	11.0	5.5	Complied
Middle	5200	7.8	11.0	3.2	Complied
Top	5240	7.6	11.0	3.4	Complied

Results: 802.11n / 20 MHz / BPSK / MCS0 / SISO

Channel	Frequency (MHz)	PPSD (dBm /MHz)	Limit (dBm /MHz)	Margin (dB)	Result
Bottom	5180	5.3	11.0	5.7	Complied
Middle	5200	7.4	11.0	3.6	Complied
Top	5240	7.2	11.0	3.8	Complied

Results: 802.11n / 40 MHz / BPSK / MCS0 / SISO

Channel	Frequency (MHz)	PPSD (dBm /MHz)	Duty cycle correction factor (dB)	Corrected PPSS (dBm /MHz)	Limit (dBm /MHz)	Margin (dB)	Result
Bottom	5190	1.5	0.1	1.6	11.0	9.4	Complied
Top	5230	3.7	0.1	3.8	11.0	7.2	Complied

Results: 802.11ac / 80 MHz / BPSK / MCS0 / SISO

Channel	Frequency (MHz)	PPSD (dBm /MHz)	Duty cycle correction factor (dB)	Corrected PPSS (dBm /MHz)	Limit (dBm /MHz)	Margin (dB)	Result
Single	5210	-2.9	0.2	-2.7	11.0	13.7	Complied

Results: 802.11n / 20 MHz / BPSK / MCS0 / MIMO

Channel	Frequency (MHz)	PPSD Port 1 (dBm /MHz)	PPSD Port 2 (dBm /MHz)	Combined PPSS (dBm /MHz)	Limit (dBm /MHz)	Margin (dB)	Result
Bottom	5180	5.6	4.2	8.0	11.0	3.0	Complied
Middle	5200	5.0	3.4	7.3	11.0	3.7	Complied
Top	5240	4.9	3.7	7.4	11.0	3.6	Complied

Transmitter Maximum Power Spectral Density (5.15-5.25 GHz band) (continued)**Results: 802.11n / 40 MHz / BPSK / MCS0 / MIMO / 5.25-5.35 GHz band**

Channel	Frequency (MHz)	Port 1			Port 2		
		PPSD (dBm /MHz)	Duty Cycle Correction (dB)	Corrected PPSD (dBm /MHz)	PPSD (dBm /MHz)	Duty Cycle Correction (dB)	Corrected PPSD (dBm /MHz)
Bottom	5190	-0.8	0.1	-0.7	-2.5	0.1	-2.4
Top	5230	4.2	0.1	4.3	2.6	0.1	2.7

Channel	Frequency (MHz)	Corrected PPSD Port 1 (dBm /MHz)	Corrected PPSD Port 2 (dBm /MHz)	Combined PPSD (dBm /MHz)	Limit (dBm /MHz)	Margin (dB)	Result
Bottom	5190	-0.7	-2.4	1.5	11.0	9.5	Complied
Top	5230	4.3	2.7	6.6	11.0	4.4	Complied

Results: 802.11ac / 80 MHz / BPSK / MCS0x1 / MIMO

Channel	Frequency (MHz)	Port 1			Port 2		
		PPSD (dBm /MHz)	Duty Cycle Correction (dB)	Corrected PPSD (dBm /MHz)	PPSD (dBm /MHz)	Duty Cycle Correction (dB)	Corrected PPSD (dBm /MHz)
Single	5210	-3.2	0.2	-3.0	-4.9	0.2	-4.7

Channel	Frequency (MHz)	Corrected PPSD Port 1 (dBm /MHz)	Corrected PPSD Port 2 (dBm /MHz)	Combined PPSD (dBm /MHz)	Limit (dBm /MHz)	Margin (dB)	Result
Single	5210	-3.0	-4.7	-0.8	11.0	11.8	Complied

Transmitter Maximum Power Spectral Density (5.25-5.35 GHz & 5.47-5.725 GHz bands)**Test Summary:**

Test Engineer:	Georgios Vrezas	Test Dates:	28 June 2016 & 21 July 2016
Test Sample IMEI:	358640070098109		

FCC Reference:	Part 15.407(a)(2)
Test Method Used:	KDB 789033 D02 Section II.F. referencing II.E.2.b) and II.E.2.d)

Environmental Conditions:

Temperature (°C):	24 to 25
Relative Humidity (%):	45 to 46

Note(s):

1. FCC Part 15.407(a)(2) limit for PPSD in the 5.25-5.35 GHz and 5.47-5.725 GHz operating bands is <11 dBm/MHz.
2. As the power spectral density test uses the same test method as the output power test, before the power is integrated across the 26 dB bandwidth, the conducted power spectral density plots are located in the conducted output power section 5.2.4 of this test report. The peak spectral density was measured by placing a marker on the peak of the signal and the results entered in the tables below.

**Transmitter Peak Power Spectral Density (5.25-5.35 GHz & 5.47-5.725 GHz bands)
(continued)**

Results: 802.11a / 20 MHz / BPSK / 6 Mbps / 5.25-5.35 GHz band

Channel	Frequency (MHz)	PPSD (dBm /MHz)	Limit (dBm /MHz)	Margin (dB)	Result
Bottom	5260	7.6	11.0	3.4	Complied
Middle	5300	7.5	11.0	3.5	Complied
Top	5320	4.4	11.0	6.6	Complied

Results: 802.11n / 20 MHz / BPSK / MCS0 / SISO / 5.25-5.35 GHz band

Channel	Frequency (MHz)	PPSD (dBm /MHz)	Limit (dBm /MHz)	Margin (dB)	Result
Bottom	5260	7.3	11.0	3.7	Complied
Middle	5280	7.1	11.0	3.9	Complied
Top	5320	4.2	11.0	6.8	Complied

Results: 802.11n / 40 MHz / BPSK / MCS0 / SISO / 5.25-5.35 GHz band

Channel	Frequency (MHz)	PPSD (dBm /MHz)	Duty Cycle Correction (dB)	Corrected PPSD (dBm /MHz)	Limit (dBm /MHz)	Margin (dB)	Result
Bottom	5270	3.7	0.1	3.8	11.0	7.2	Complied
Top	5310	-0.1	0.1	0.0	11.0	11.0	Complied

Results: 802.11ac / 80 MHz / BPSK / MCS0 / SISO / 5.25-5.35 GHz band

Channel	Frequency (MHz)	PPSD (dBm /MHz)	Duty Cycle Correction (dB)	Corrected PPSD (dBm /MHz)	Limit (dBm /MHz)	Margin (dB)	Result
Single	5290	-4.3	0.2	-4.1	11.0	15.1	Complied

Results: 802.11n / 20 MHz / BPSK / MCS0 / MIMO / 5.25-5.35 GHz band

Channel	Frequency (MHz)	PPSD Port 1 (dBm /MHz)	PPSD Port 2 (dBm /MHz)	Combined PPSD (dBm /MHz)	Limit (dBm /MHz)	Margin (dB)	Result
Bottom	5260	5.0	3.7	7.4	11.0	3.6	Complied
Middle	5280	5.1	3.4	7.3	11.0	3.7	Complied
Top	5320	3.9	2.5	6.3	11.0	4.7	Complied

Transmitter Peak Power Spectral Density (5.25-5.35 GHz & 5.47-5.725 GHz bands)
(continued)

Results: 802.11n / 40 MHz / BPSK / MCS0 / MIMO / 5.25-5.35 GHz band

Channel	Frequency (MHz)	Port 1			Port 2		
		PPSD (dBm /MHz)	Duty Cycle Correction (dB)	Corrected PPSD (dBm /MHz)	PPSD (dBm /MHz)	Duty Cycle Correction (dB)	Corrected PPSD (dBm /MHz)
Bottom	5270	4.1	0.1	4.2	2.4	0.1	2.5
Top	5310	-0.8	0.1	-0.7	-2.0	0.1	-1.9

Channel	Frequency (MHz)	Corrected PPSD Port 1 (dBm /MHz)	Corrected PPSD Port 2 (dBm /MHz)	Combined PPSD (dBm /MHz)	Limit (dBm /MHz)	Margin (dB)	Result
Bottom	5270	4.2	2.5	6.4	11.0	4.6	Complied
Top	5310	-0.7	-1.9	1.8	11.0	9.2	Complied

Results: 802.11ac / 80 MHz / BPSK / MCS0x1 / MIMO / 5.25-5.35 GHz band

Channel	Frequency (MHz)	Port 1			Port 2		
		PPSD (dBm /MHz)	Duty Cycle Correction (dB)	Corrected PPSD (dBm /MHz)	PPSD (dBm /MHz)	Duty Cycle Correction (dB)	Corrected PPSD (dBm /MHz)
Single	5290	-5.3	0.2	-5.1	-6.9	0.2	-6.7

Channel	Frequency (MHz)	Corrected PPSD Port 1 (dBm /MHz)	Corrected PPSD Port 2 (dBm /MHz)	Combined PPSD (dBm /MHz)	Limit (dBm /MHz)	Margin (dB)	Result
Single	5290	-5.1	-6.7	-2.8	11.0	13.8	Complied

Results: 802.11a / 20 MHz / BPSK / 6 Mbps / 5.47-5.725 GHz band

Channel	Frequency (MHz)	PPSD (dBm /MHz)	Limit (dBm /MHz)	Margin (dB)	Result
Bottom	5500	4.2	11.0	6.8	Complied
Middle	5580	7.5	11.0	3.5	Complied
Top	5700	4.6	11.0	6.4	Complied

Results: 802.11n / 20 MHz / BPSK / MCS0 / SISO / 5.47-5.725 GHz band

Channel	Frequency (MHz)	PPSD (dBm /MHz)	Limit (dBm /MHz)	Margin (dB)	Result
Bottom	5500	3.7	11.0	7.3	Complied
Middle	5580	7.2	11.0	3.8	Complied
Top	5700	4.2	11.0	6.8	Complied

Transmitter Peak Power Spectral Density (5.25-5.35 GHz & 5.47-5.725 GHz bands)
(continued)

Results: 802.11n / 40 MHz / BPSK / MCS0 / SISO / 5.47-5.725 GHz band

Channel	Frequency (MHz)	Conducted Power (dBm)	Duty Cycle Correction (dB)	Corrected Conducted Power (dBm)	Limit (dBm)	Margin (dB)	Result
Bottom	5510	0.0	0.1	0.1	11.0	10.9	Complied
Middle	5550	4.1	0.1	4.2	11.0	6.8	Complied
Top	5670	2.3	0.1	2.4	11.0	8.6	Complied

Results: 802.11ac / 80 MHz / BPSK / MCS0 / SISO / 5.47-5.725 GHz band

Channel	Frequency (MHz)	PPSD (dBm /MHz)	Duty Cycle Correction (dB)	Corrected PPSD (dBm /MHz)	Limit (dBm /MHz)	Margin (dB)	Result
Bottom	5530	-3.5	0.2	-3.3	11.0	14.3	Complied
Top	5610	1.1	0.2	1.3	11.0	9.7	Complied

Results: 802.11n / 20 MHz / BPSK / MCS0 / MIMO / 5.47-5.725 GHz band

Channel	Frequency (MHz)	PPSD Port 1 (dBm /MHz)	PPSD Port 2 (dBm /MHz)	Combined PPSD (dBm /MHz)	Limit (dBm /MHz)	Margin (dB)	Result
Bottom	5500	3.9	2.7	6.4	11.0	4.6	Complied
Middle	5580	5.0	3.5	7.3	11.0	3.7	Complied
Top	5700	4.5	2.8	6.7	11.0	4.3	Complied

Results: 802.11n / 40 MHz / BPSK / MCS0 / MIMO / 5.47-5.725 GHz band

Channel	Frequency (MHz)	Port 1			Port 2		
		PPSD (dBm /MHz)	Duty Cycle Correction (dB)	Corrected PPSD (dBm /MHz)	PPSD (dBm /MHz)	Duty Cycle Correction (dB)	Corrected PPSD (dBm /MHz)
Bottom	5510	0.3	0.1	0.4	-0.9	0.1	-0.8
Middle	5550	4.1	0.1	4.2	2.5	0.1	2.6
Top	5670	2.5	0.1	2.6	1.2	0.1	1.3

Channel	Frequency (MHz)	Corrected PPSD Port 1 (dBm /MHz)	Corrected PPSD Port 2 (dBm /MHz)	Combined PPSD (dBm /MHz)	Limit (dBm /MHz)	Margin (dB)	Result
Bottom	5510	0.4	-0.8	2.9	11.0	8.1	Complied
Middle	5550	4.2	2.6	6.5	11.0	4.5	Complied
Top	5670	2.6	1.3	5.0	11.0	6.0	Complied

Transmitter Peak Power Spectral Density (5.25-5.35 GHz & 5.47-5.725 GHz bands)
(continued)

Results: 802.11ac / 80 MHz / BPSK / MCS0x1 / MIMO / 5.47-5.725 GHz band

Channel	Frequency (MHz)	Port 1			Port 2		
		PPSD (dBm /MHz)	Duty Cycle Correction (dB)	Corrected PPSD (dBm /MHz)	PPSD (dBm /MHz)	Duty Cycle Correction (dB)	Corrected PPSD (dBm /MHz)
Bottom	5530	-4.1	0.2	-3.9	-5.0	0.2	-4.8
Top	5610	0.8	0.2	1.0	-0.5	0.2	-0.3

Channel	Frequency (MHz)	Corrected PPSD Port 1 (dBm /MHz)	Corrected PPSD Port 2 (dBm /MHz)	Combined PPSD (dBm /MHz)	Limit (dBm /MHz)	Margin (dB)	Result
Bottom	5530	-3.9	-4.8	-1.3	11.0	12.3	Complied
Top	5610	1.0	-0.3	3.4	11.0	7.6	Complied

Transmitter Maximum Power Spectral Density (Channels that straddle the U-NII-2C and U-NII-3 bands at 5725 MHz)

Test Summary:

Test Engineer:	Georgios Vrezas	Test Date:	28 June 2016
Test Sample IMEI:	358640070098109		

FCC Reference:	Part 15.407(a)(2)
Test Method Used:	KDB 789033 D02 Section II.F. referencing II.E.2.b) and II.E.2.d)

Environmental Conditions:

Temperature (°C):	24
Relative Humidity (%):	45

Note(s):

1. Channels that straddle the U-NII-2C and U-NII-3 bands at 5725 MHz, need to meet requirements of both U-NII bands. Due to maximum power spectral density limit being more stringent on U-NII-2C, compliance is shown against the limits of U-NII-2C. By default the EUT also complies on U-NII-3.
2. FCC Part 15.407(a)(2) limit for PPSD in the 5.47-5.725 GHz operating band is <11 dBm/MHz.
3. As the power spectral density test uses the same test method as the output power test, before the power is integrated across the 26 dB bandwidth, the conducted power spectral density plots are located in the conducted output power section 5.2.4 of this test report. The peak spectral density was measured by placing a marker on the peak of the signal and the results entered in the tables below.

Transmitter Peak Power Spectral Density (Channels that straddle the U-NII-2C and U-NII-3 bands at 5725 MHz) (continued)

Results: 802.11a / 20 MHz / BPSK / 6 Mbps

Channel	Frequency (MHz)	PPSD (dBm /MHz)	Limit (dBm /MHz)	Margin (dB)	Result
Single	5720	7.4	11.0	3.6	Complied

Results: 802.11n / 20 MHz / BPSK / MCS0 / SISO

Channel	Frequency (MHz)	PPSD (dBm /MHz)	Limit (dBm /MHz)	Margin (dB)	Result
Single	5720	7.2	11.0	3.8	Complied

Results: 802.11n / 40 MHz / BPSK / MCS0 / SISO

Channel	Frequency (MHz)	Conducted Power (dBm)	Duty Cycle Correction (dB)	Corrected Conducted Power (dBm)	Limit (dBm)	Margin (dB)	Result
Single	5710	3.6	0.1	3.7	11.0	7.3	Complied

Results: 802.11ac / 80 MHz / BPSK / MCS0 / SISO

Channel	Frequency (MHz)	PPSD (dBm /MHz)	Duty Cycle Correction (dB)	Corrected PPSS (dBm /MHz)	Limit (dBm /MHz)	Margin (dB)	Result
Single	5690	0.8	0.2	1.0	11.0	10.0	Complied

Results: 802.11n / 20 MHz / BPSK / MCS0 / MIMO

Channel	Frequency (MHz)	PPSD Port 1 (dBm /MHz)	PPSD Port 2 (dBm /MHz)	Combined PPSS (dBm /MHz)	Limit (dBm /MHz)	Margin (dB)	Result
Single	5720	5.0	3.8	7.5	11.0	3.5	Complied

Results: 802.11n / 40 MHz / BPSK / MCS0 / MIMO / 5.47-5.725 GHz band

Channel	Frequency (MHz)	Port 1			Port 2		
		PPSD (dBm /MHz)	Duty Cycle Correction (dB)	Corrected PPSS (dBm /MHz)	PPSD (dBm /MHz)	Duty Cycle Correction (dB)	Corrected PPSS (dBm /MHz)
Single	5710	4.1	0.1	4.2	2.6	0.1	2.7

Channel	Frequency (MHz)	Corrected PPSS Port 1 (dBm /MHz)	Corrected PPSS Port 2 (dBm /MHz)	Combined PPSS (dBm /MHz)	Limit (dBm /MHz)	Margin (dB)	Result
Single	5710	4.2	2.7	6.5	11.0	4.5	Complied

Transmitter Peak Power Spectral Density (Channels that straddle the U-NII-2C and U-NII-3 bands at 5725 MHz) (continued)

Results: 802.11ac / 80 MHz / BPSK / MCS0x1 / MIMO / 5.47-5.725 GHz band

Channel	Frequency (MHz)	Port 1			Port 2		
		PPSD (dBm /MHz)	Duty Cycle Correction (dB)	Corrected PPSD (dBm /MHz)	PPSD (dBm /MHz)	Duty Cycle Correction (dB)	Corrected PPSD (dBm /MHz)
Single	5690	1.1	0.2	1.3	-0.6	0.2	-0.4

Channel	Frequency (MHz)	Corrected PPSD Port 1 (dBm /MHz)	Corrected PPSD Port 2 (dBm /MHz)	Combined PPSD (dBm /MHz)	Limit (dBm /MHz)	Margin (dB)	Result
Single	5690	1.3	-0.4	3.5	11.0	7.5	Complied

Transmitter Maximum Power Spectral Density (5.725-5.85 GHz band)**Test Summary:**

Test Engineer:	Georgios Vrezas	Test Dates:	28 June 2016 & 21 July 2016
Test Sample IMEI:	358640070098109		

FCC Reference:	Part 15.407(a)(3)
Test Method Used:	KDB 789033 D02 Section II.F. referencing II.E.2.b) and II.E.2.d)

Environmental Conditions:

Temperature (°C):	24 to 25
Relative Humidity (%):	45 to 46

Note(s):

1. FCC Part 15.407(a)(3) limit for PPSD in the 5.725-5.85 GHz operating band is <30 dBm/500 kHz.
2. In accordance with ANSI C63.10 Section 4.1.4.1, use of bandwidths greater than those specified can produce higher readings. Compliance against the applicable limits is shown using a 1 MHz resolution bandwidth. This was deemed worst case.
3. As the power spectral density test uses the same test method as the output power test, before the power is integrated across the 26 dB bandwidth, the conducted power spectral density plots are located in the conducted output power section 5.2.4 of this test report. The peak spectral density was measured by placing a marker on the peak of the signal and the results entered in the tables below.

Transmitter Maximum Power Spectral Density (5.725-5.85 GHz band) (continued)**Results: 802.11a / 20 MHz / BPSK / 6 Mbps**

Channel	Frequency (MHz)	PPSD (dBm / 1 MHz)	Limit (dBm / 500 kHz)	Margin (dB)	Result
Bottom	5745	8.2	30.0	21.8	Complied
Middle	5785	7.6	30.0	22.4	Complied
Top	5825	8.2	30.0	21.8	Complied

Results: 802.11n / 20 MHz / BPSK / MCS0 / SISO

Channel	Frequency (MHz)	PPSD (dBm / 1 MHz)	Limit (dBm / 500 kHz)	Margin (dB)	Result
Bottom	5745	8.0	30.0	22.0	Complied
Middle	5785	8.0	30.0	22.0	Complied
Top	5825	7.2	30.0	22.8	Complied

Results: 802.11n / 40 MHz / BPSK / MCS0 / SISO

Channel	Frequency (MHz)	PPSD (dBm / 1 MHz)	Duty cycle correction factor (dB)	Corrected PPSS (dBm / 1 MHz)	Limit (dBm / 500 kHz)	Margin (dB)	Result
Bottom	5755	3.9	0.1	4.0	30.0	26.0	Complied
Top	5795	5.0	0.1	5.1	30.0	24.9	Complied

Results: 802.11ac / 80 MHz / BPSK / MCS0 / SISO

Channel	Frequency (MHz)	PPSD (dBm / 1 MHz)	Duty cycle correction factor (dB)	Corrected PPSS (dBm / 1 MHz)	Limit (dBm / 500 kHz)	Margin (dB)	Result
Single	5775	0.7	0.2	0.9	30.0	29.1	Complied

Results: 802.11n / 20 MHz / BPSK / MCS0 / MIMO

Channel	Frequency (MHz)	PPSD Port 1 (dBm / 1 MHz)	PPSD Port 2 (dBm / 1 MHz)	Combined PPSS (dBm / 1 MHz)	Limit (dBm / 500 kHz)	Margin (dB)	Result
Bottom	5745	7.2	6.4	9.8	30.0	20.2	Complied
Middle	5785	8.1	7.0	10.6	30.0	19.4	Complied
Top	5825	8.1	6.6	10.4	30.0	19.6	Complied

Transmitter Maximum Power Spectral Density (5.725-5.85 GHz band) (continued)**Results: 802.11n / 40 MHz / BPSK / MCS0 / MIMO**

Channel	Frequency (MHz)	Port 1			Port 2		
		PPSD (dBm / 1 MHz)	Duty Cycle Correction (dB)	Corrected PPSD (dBm / 1 MHz)	Conducted PPSD (dBm / 1 MHz)	Duty Cycle PPSD (dBm / 1 MHz)	Corrected PPSD (dBm / 1 MHz)
Bottom	5755	3.9	0.1	4.0	2.5	0.1	2.6
Top	5795	4.8	0.1	4.9	3.8	0.1	3.9

Channel	Frequency (MHz)	Corrected PPSD Port 1 (dBm / 1 MHz)	Corrected PPSD Port 2 (dBm / 1 MHz)	Combined PPSD (dBm / 1 MHz)	Limit (dBm / 500 kHz)	Margin (dB)	Result
Bottom	5755	4.0	2.6	6.4	30.0	23.6	Complied
Top	5795	4.9	3.9	7.4	30.0	22.6	Complied

Results: 802.11ac / 80 MHz / BPSK / MCS0x1 / MIMO

Channel	Frequency (MHz)	Port 1			Port 2		
		PPSD (dBm / 1 MHz)	Duty Cycle Correction (dB)	Corrected PPSD (dBm / 1 MHz)	Conducted PPSD (dBm / 1 MHz)	Duty Cycle PPSD (dBm / 1 MHz)	Corrected PPSD (dBm / 1 MHz)
Single	5775	0.2	0.2	0.4	-1.2	0.2	-1.0

Channel	Frequency (MHz)	Corrected PPSD Port 1 (dBm / 1 MHz)	Corrected PPSD Port 2 (dBm / 1 MHz)	Combined PPSD (dBm / 1 MHz)	Limit (dBm / 500 kHz)	Margin (dB)	Result
Single	5775	0.4	-1.0	2.8	30.0	27.2	Complied

Transmitter Maximum Power Spectral Density (continued)**Test Equipment Used:**

Asset No.	Instrument	Manufacturer	Type No.	Serial No.	Date Calibration Due	Cal. Interval (Months)
M1659	Thermohygrometer	JM Handelspunkt	30.5015.13	None stated	02 Apr 2017	12
M1835	Signal Analyser	Rohde & Schwarz	FSV30	103050	27 Feb 2017	12
M1867	Attenuator	Huber + Suhner AG	6820.17.B	07101	Calibrated before use	-
A2847	Attenuator	Radiall	R411.820.121	24671450	Calibrated before use	-
A2345	Attenuator	Macom	2082-6043-20	None stated	Calibrated before use	-
A2952	RF Switch	Pickering Interfaces	64-102-002 & 40-881-001	XZ361012 & X361507	Calibrated before use	-
S0538	DC Power Supply	TTi	PL154	250135	Calibrated before use	-
M1818	Multimeter	Fluke	79III	71811580	27 Apr 2017	12
M1252	Signal Generator	Hewlett Packard	83640A	3119A00489	26 Oct 2017	24

5.2.6. Transmitter Out of Band Radiated Emissions**Test Summary:**

Test Engineer:	Nick Steele	Test Date:	17 June 2016
Test Sample Serial Number:	C7CRR00BHCPX		

FCC Reference:	Parts 15.407(b)(4),(6),(7) & 15.209(a)
Test Method Used:	KDB 789033 II.G. & ANSI C63.10 Sections 6.3 and 6.5
Frequency Range:	30 MHz to 1000 MHz

Environmental Conditions:

Temperature (°C):	24
Relative Humidity (%):	47

Note(s):

- Measurements below 1 GHz were limited to the 5.725-5.85 GHz band, the EUT was transmitting with a data rate of MCS0 (802.11n HT20 / MIMO) as it produced the highest conducted output power and was therefore deemed worst case.
- Pre-scans with the EUT transmitting on the middle channel were measured according to FCC Part 15.407(b)(4)(i) states for transmitters operating in the band 5.725 to 5.85 GHz: all emissions shall be limited to a level of -27 dBm/MHz at 75 MHz or more above or below the band edge increasing linearly to 10 dBm/MHz at 25 MHz above or below the band edge, and from 25 MHz above or below the band edge increasing linearly to a level of 15.6 dBm/MHz at 5 MHz above or below the band edge, and from 5 MHz above or below the band edge increasing linearly to a level of 27 dBm/MHz at the band edge. Part(b)(7) states the provisions of 15.205 apply e.g. restricted bands of operation.
- The final measured value, for the given emission in the field strength result tables, incorporates the calibrated antenna factor and cable loss.
- The preliminary scans showed similar emission levels below 1 GHz, for each channel of operation. Therefore final radiated emissions measurements were performed with the EUT set to the middle channel only.
- No emissions were shown on the pre-scan plot; therefore the highest peak noise floor reading of the measuring receiver was recorded in the table below.
- Measurements below 1 GHz were performed in a semi-anechoic chamber (Asset Number K0017) at a distance of 3 metres. The EUT was placed at a height of 80 cm above the reference ground plane in the centre of the chamber turntable. Maximum emission levels were determined by height searching the measurement antenna over the range 1 metre to 4 metres.
- Pre-scans were performed and markers placed on the highest measured levels. The test receiver resolution bandwidth was set to 100 kHz and video bandwidth 300 kHz. The sweep time was set to auto. A peak detector was used, sweep time was set to auto and trace mode was Max Hold.

Transmitter Out of Band Radiated Emissions (continued)

Test setup for radiated measurements:

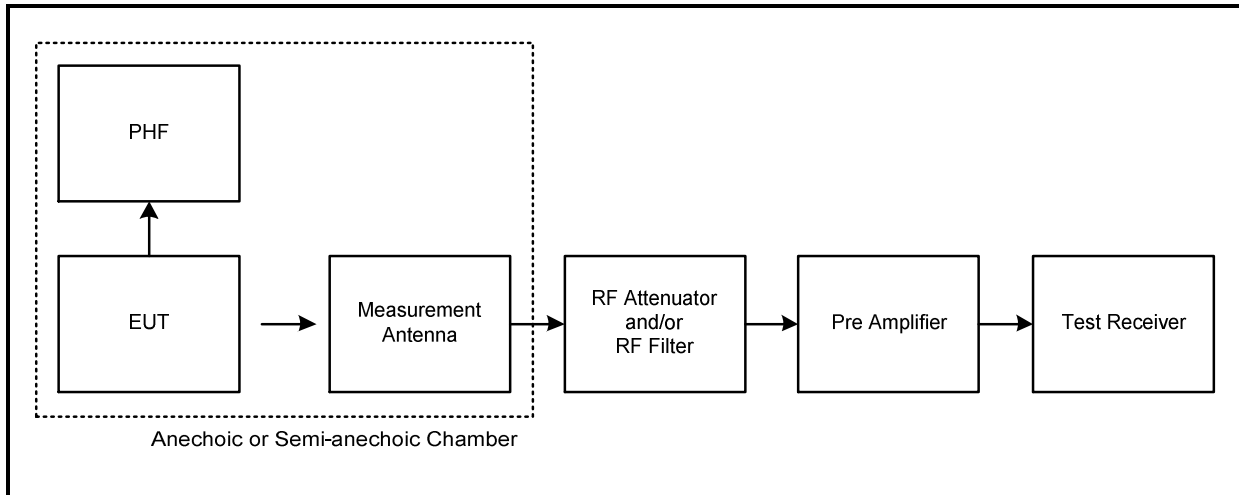

Results: Middle Channel / Field Strength

Frequency (MHz)	Antenna Polarity	Level (dBµV/m)	Limit (dBµV/m)	Margin (dB)	Result
994.396	Vertical	26.9	54.0	27.1	Complied

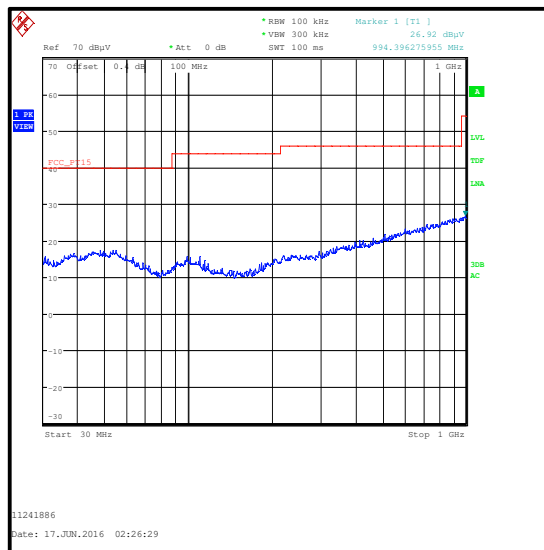

Test Equipment Used:

Asset No.	Instrument	Manufacturer	Type No.	Serial No.	Date Calibration Due	Cal. Interval (Months)
M2003	Thermohygrometer	Testo	608-H1	45046641	22 Apr 2017	12
K0017	3m RSE Chamber	Rainford EMC	N/A	N/A	17 May 2017	12
M1995	Test Receiver	Rohde & Schwarz	ESU40	100428	21 Mar 2017	12
A2888	Antenna	Schwarzbeck	VULB 9163	9163-941	07 Apr 2017	12
A2131	Low Pass Filter	AtlanTecRF	AFL-02000	JFB1004-002	30 Apr 2017	12

Transmitter Out of Band Radiated Emissions (5.725-5.85 GHz band operation) (continued)**Test Summary:**

Test Engineers:	Nick Steele & David Doyle	Test Date:	16 June 2016
Test Sample Serial Number:	C7CRR00BHCPX		

FCC Reference:	Part 15.407(b)(4)(i),(7) & 15.209(a)
Test Method Used:	KDB 789033 II.G. & ANSI C63.10 Sections 6.3 and 6.6
Frequency Range:	1 GHz to 40 GHz

Environmental Conditions:

Temperature (°C):	27
Relative Humidity (%):	40

Note(s):

1. FCC Part 15.407(b)(4)(i) states for transmitters operating in the band 5.725 to 5.85 GHz: all emissions shall be limited to a level of -27 dBm/MHz at 75 MHz or more above or below the band edge increasing linearly to 10 dBm/MHz at 25 MHz above or below the band edge, and from 25 MHz above or below the band edge increasing linearly to a level of 15.6 dBm/MHz at 5 MHz above or below the band edge, and from 5 MHz above or below the band edge increasing linearly to a level of 27 dBm/MHz at the band edge. Part(b)(7) states the provisions of 15.205 apply e.g. restricted bands of operation.
2. Pre-scans were performed with the EUT transmitting with a data rate of 802.11n / HT20 / MCS0 / MIMO on middle channel in this band as it produced the highest EIRP and was therefore deemed worst case. An inquiry was made to the FCC and the response was pre-scans could be performed in the band with the highest conducted output power and all final measurements should be performed on any emissions seen in each band.
3. No emissions were shown on the pre-scan plots; therefore the highest peak noise floor reading of the measuring receiver was recorded in the table below.
4. Middle channel results are recorded in this report and are representative of bottom and top channel results which are held on the UL IT server and available for inspection on request.
5. Appropriate RF filters and attenuators were used during pre-scans and final measurements. Insertion losses were entered on the spectrum analyser as RF levels offsets.
6. Tests were performed as field strength measurements. As the highest noise floor reading occurred in a restricted band, the maximum peak field strength was compared to the peak limit (74 dBµV/m) and the average field strength was compared to the average limit (54 dBµV/m).
7. The final measured value, for the given emission in the field strength result tables, incorporates the calibrated antenna factor and cable loss.
8. The emission shown on the 1 GHz to 8 GHz plot is the EUT fundamental.
9. Measurements were performed across the two restricted bands closest to the bands of operation with the EUT transmitting on the top channel in the 5.25 to 5.35 GHz band. Plots are included in this section of the test report. Peak and average measurements were made.
10. Pre-scans above 1 GHz were performed in a semi-anechoic chamber (Asset Number K0017) at a distance of 3 metres. The EUT was placed at a height of 1.5 metres above the reference ground plane in the centre of the chamber turntable. All measurement antennas were placed at a fixed height of 1.5 metres above the test chamber floor, in line with the EUT.

Transmitter Out of Band Radiated Emissions (5.725-5.85 GHz band operation) (continued)

Results: Middle Channel / Field Strength / Peak

Frequency (MHz)	Antenna Polarity	Peak Level (dBμV/m)	Peak Limit (dBμV/m)	Margin (dB)	Result
7326.923	Vertical	58.5	74.0	15.5	Complied

Results: Middle Channel / Field Strength / Average

Frequency (MHz)	Antenna Polarity	Average Level (dBμV/m)	Average Limit (dBμV/m)	Margin (dB)	Result
7977.564	Vertical	48.5	54.0	5.5	Complied

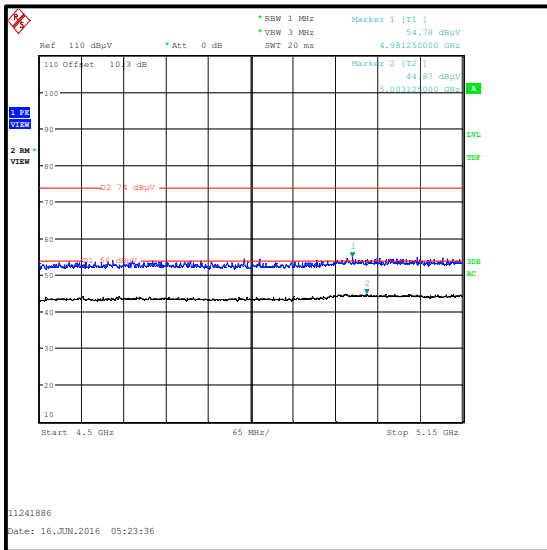
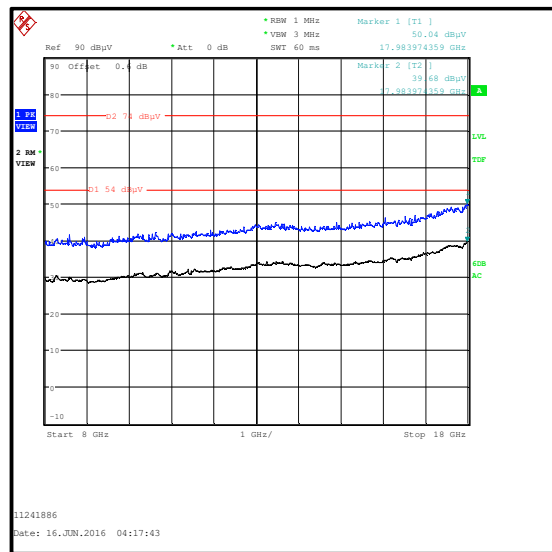
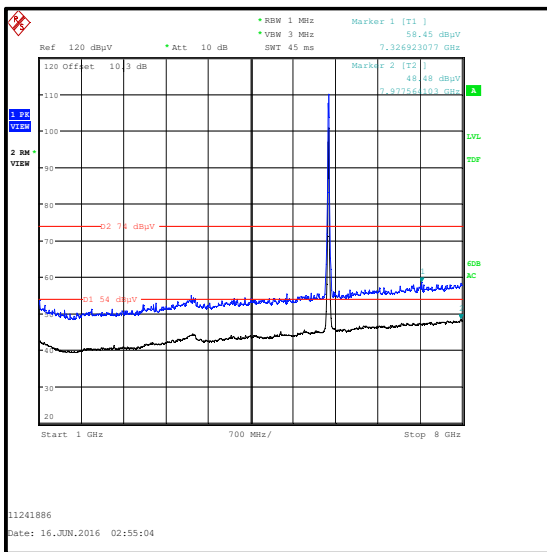

Restricted Band 4.5 GHz to 5.15 GHz

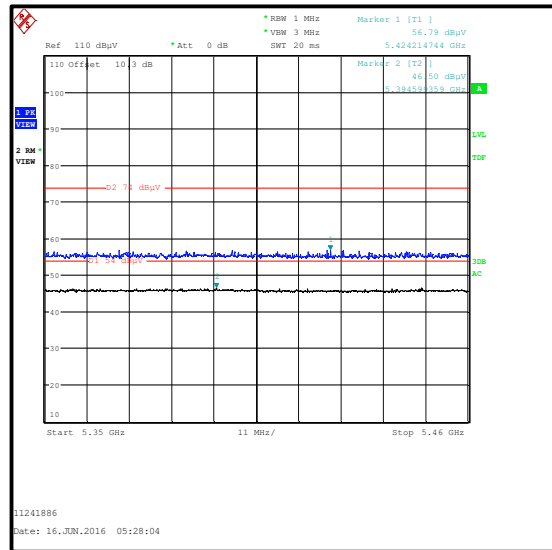

Restricted Band 5.35 GHz to 5.46 GHz

Transmitter Out of Band Radiated Emissions (5.725-5.85 GHz band operation) (continued)

Test Equipment Used:

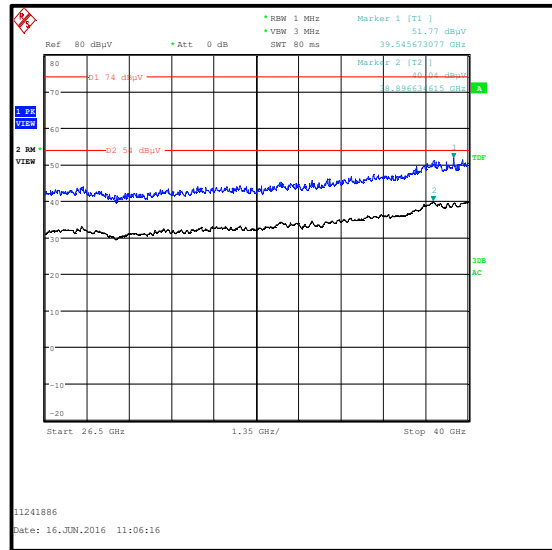
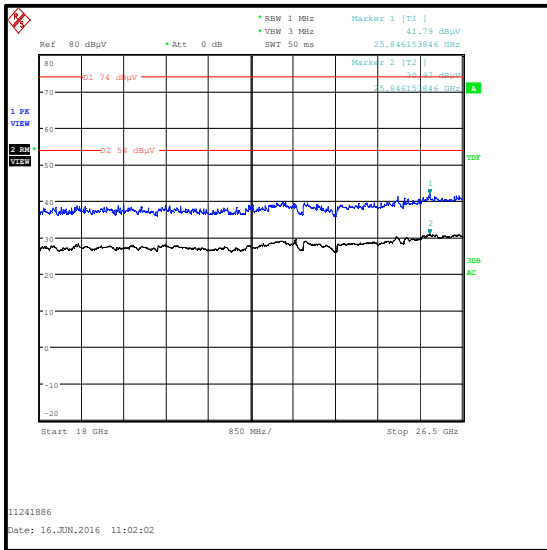

Test Equipment Used:

Asset No.	Instrument	Manufacturer	Type No.	Serial No.	Date Calibration Due	Cal. Interval (Months)
M2003	Thermohygrometer	Testo	608-H1	45046641	22 Apr 2017	12
K0017	3m RSE Chamber	Rainford EMC	N/A	N/A	17 May 2017	12
M1995	Test Receiver	Rohde & Schwarz	ESU40	100428	21 Mar 2017	12
A2889	Antenna	Schwarzbeck	BBHA 9120 B	BBHA 9120 B 653	07 Apr 2017	12
A2890	Antenna	Schwarzbeck	HWRD 750	014	06 May 2017	12
A2892	Antenna	Schwarzbeck	BBHA 9170	9170-727	07 Apr 2017	12
A2863	Pre Amplifier	Agilent	8449B	3008A02100	07 Jan 2017	12
A2891	Pre Amplifier	Schwarzbeck	BBV 9718	9718-306	07 Apr 2017	12
A2893	Pre-Amplifier	Schwarzbeck	BBV 9721	9721-021	07 Apr 2017	12
A2916	Attenuator	AtlanTecRF	AN18W5-10	832827#1	19 May 2017	12
A2947	High Pass Filter	AtlanTecRF	AFH-07000	1601900001	01 Jun 2017	12

5.2.7. Transmitter Band Edge Radiated Emissions**Test Summary:**

Test Engineers:	Nick Steele David Doyle & Andrew Edwards	Test Dates:	14 June 2016 to 29 June 2016
Test Sample Serial Number:	C7CRR00BHCPX		

FCC Reference:	Parts 15.407(b)(1),(7), 15.205 & 15.209(a)
Test Method Used:	ANSI C63.10 Section 6.10 & KDB 789033 II.G.

Environmental Conditions:

Temperature (°C):	24 to 27
Relative Humidity (%):	41 to 45

Note(s):

1. The customer declared the following data rates to be used for all measurements as:
 - 802.11a – BPSK / 6 Mbps / Port 1
 - 802.11n HT20 SISO – BPSK / 6.5 Mbps / MCS0 / Port 1
 - 802.11n HT40 SISO - BPSK / 13.5 Mbps / MCS0 / Port 1
 - 802.11ac VHT80 SISO – BPSK / 29.3 Mbps / MCS0 / Port 1
 - 802.11n HT20 MIMO – BPSK / 6.5 Mbps / MCS0
 - 802.11n HT40 MIMO – BPSK / 29.3 Mbps / MCS0
 - 802.11ac VHT80 MIMO – BPSK / 29.3 Mbps / MCS0x1
2. Lower band edge measurements were performed with the EUT transmitting on the bottom channel. Upper band edge measurements were performed with the EUT transmitting on the top channel.
3. For transmitters operating in the 5.15-5.25 GHz band: all emissions outside of the 5.15-5.35 GHz band shall not exceed an EIRP of -27 dBm/MHz. However, there are restricted bands of operation below the lower band edge at 4.5-5.15 GHz and also above the upper band edge at 5.35-5.46 GHz therefore the provisions of FCC Part 15.205 apply.
4. Field strength measurements using peak and average detectors were performed in the restricted bands below 5.15 GHz and above 5.35 GHz. Field strength and EIRP results were found to be compliant with the restricted band limits and Part 15.407 out-of-band limits.
5. In accordance with KDB 789033 Section II.G.1.c) if the peak measurement is below the average limit, it is not necessary to perform a separate average measurement.
6. For all average measurements of this section, 300 sweeps were used. This satisfies the requirement for the minimum number of sweep points, as stated in ANSI C63.10 Section 12.7.7.2 Method AD f). Power averaging was used.
7. In accordance with KDB 789033 Section II.G.6.c) Method AD (vii), for average measurements, data rates where the EUT was transmitting <98% duty cycle, the duty cycle correction factor calculated in section 5.2.3 was added to the measured result.

Transmitter Band Edge Radiated Emissions (5.15-5.25 GHz band operation) (continued)**Results: 802.11a / 20 MHz / BPSK / 6 Mbps / Port 1 / Peak**

Frequency (MHz)	Level (dB μ V/m)	Limit (dB μ V/m)	Margin (dB)	Result
5149.199	59.3	74.0	14.7	Complied
5150	58.0	74.0	16.0	Complied
5350	54.9	74.0	19.1	Complied
5356.635	56.7	74.0	17.3	Complied

Results: 802.11a / 20 MHz / BPSK / 6 Mbps / Port 1 / Average

Frequency (MHz)	Level (dB μ V/m)	Limit (dB μ V/m)	Margin (dB)	Result
5150	46.1	54.0	7.9	Complied
5350	44.2	54.0	9.8	Complied
5397.548	44.4	54.0	9.6	Complied

Transmitter Band Edge Radiated Emissions (5.15-5.25 GHz band operation) (continued)

Results: 802.11a / 20 MHz / BPSK / 6 Mbps / Port 1

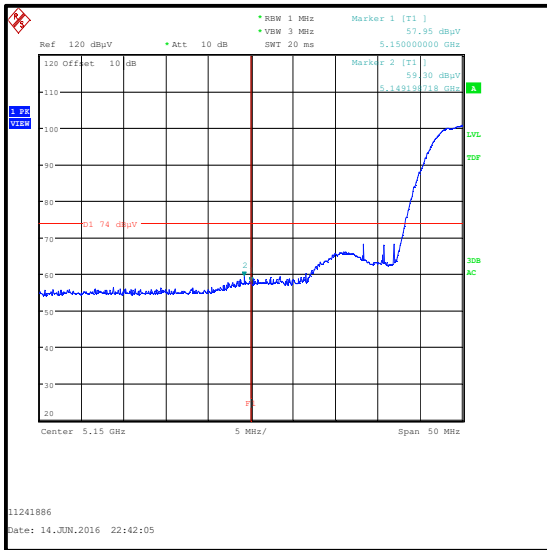

Lower Band Edge Peak Measurement

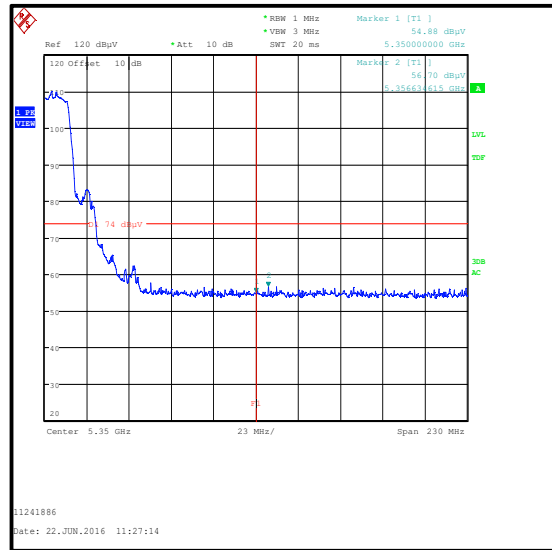

Upper Band Edge Peak Measurement

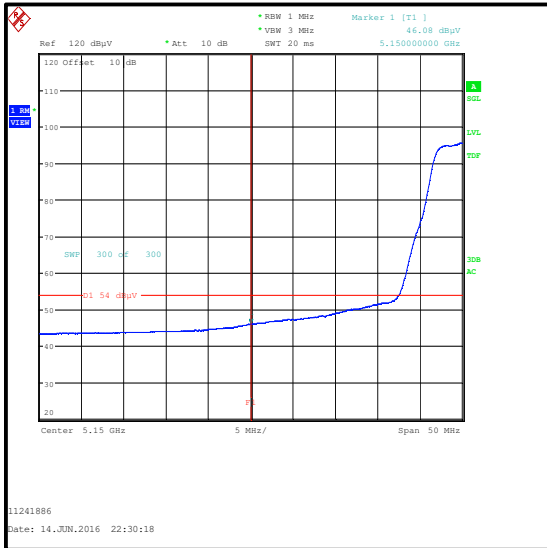

Lower Band Edge Average Measurement

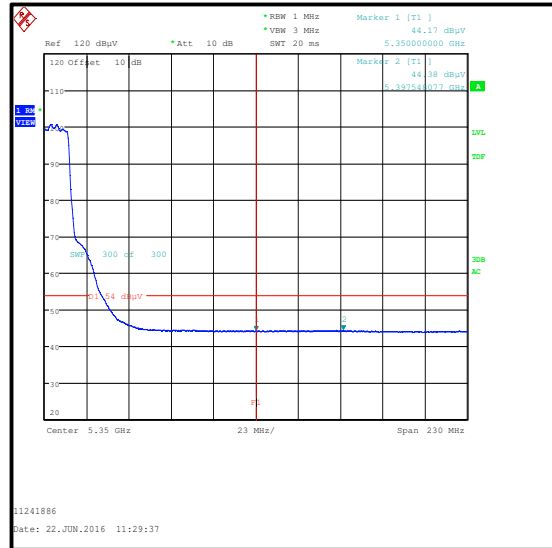

Upper Band Edge Average Measurement

Transmitter Band Edge Radiated Emissions (5.15-5.25 GHz band operation) (continued)**Results: 802.11n / 20 MHz / BPSK / MCS0 / Port 1 / SISO / Peak**

Frequency (MHz)	Level (dB μ V/m)	Limit (dB μ V/m)	Margin (dB)	Result
5148.798	64.8	74.0	9.2	Complied
5150	64.4	74.0	9.6	Complied
5350	56.2	74.0	17.8	Complied
5379.487	58.1	74.0	15.9	Complied

Results: 802.11n / 20 MHz / BPSK / MCS0 / Port 1 / SISO / Average

Frequency (MHz)	Level (dB μ V/m)	Limit (dB μ V/m)	Margin (dB)	Result
5150	46.4	54.0	7.6	Complied
5350	44.3	54.0	9.7	Complied

Transmitter Band Edge Radiated Emissions (5.15-5.25 GHz band operation) (continued)

Results: 802.11n / 20 MHz / BPSK / MCS0 / Port 1 / SISO

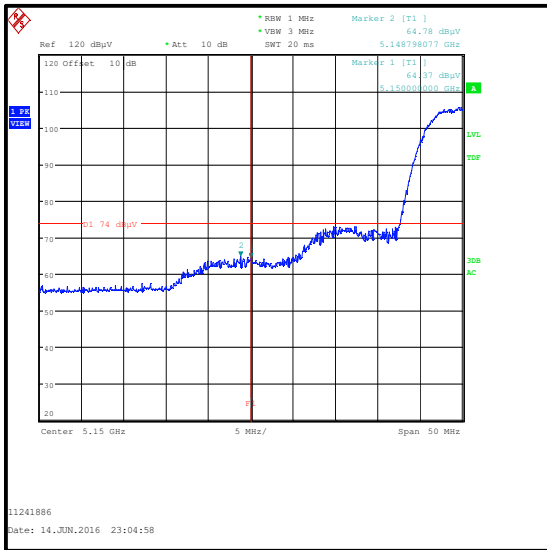

Lower Band Edge Peak Measurement

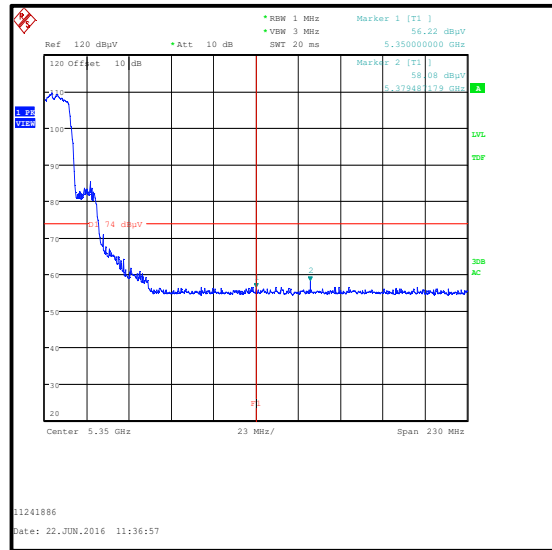

Upper Band Edge Peak Measurement

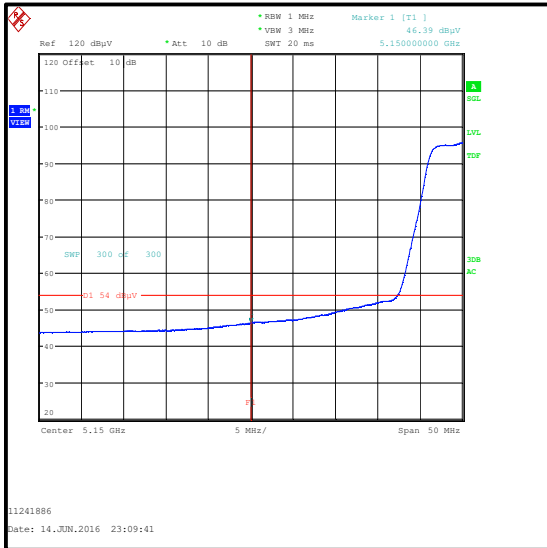

Lower Band Edge Average Measurement

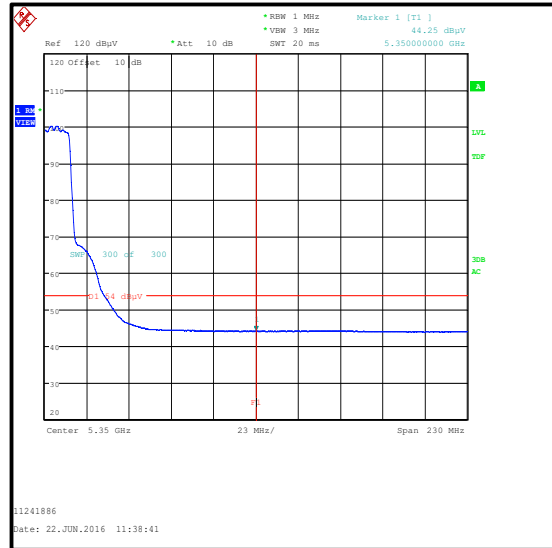

Upper Band Edge Average Measurement

Transmitter Band Edge Radiated Emissions (5.15-5.25 GHz band operation) (continued)**Results: 802.11n / 40 MHz / BPSK / MCS0 / Port 1 / SISO / Peak**

Frequency (MHz)	Level (dB μ V/m)	Limit (dB μ V/m)	Margin (dB)	Result
5146.875	63.7	74.0	10.3	Complied
5150	63.4	74.0	10.6	Complied
5350	55.4	74.0	18.6	Complied
5357.740	57.4	74.0	16.6	Complied

Results: 802.11n / 40 MHz / BPSK / MCS0 / Port 1 / SISO / Average

Frequency (MHz)	Level (dB μ V/m)	Duty Cycle correction (dB)	Corrected Level (dB μ V/m)	Limit (dB μ V/m)	Margin (dB)	Result
5150	46.8	0.1	46.9	54.0	7.1	Complied
5350	44.5	0.1	44.6	54.0	9.4	Complied

Transmitter Band Edge Radiated Emissions (5.15-5.25 GHz band operation) (continued)

Results: 802.11n / 40 MHz / BPSK / MCS0 / Port 1 / SISO

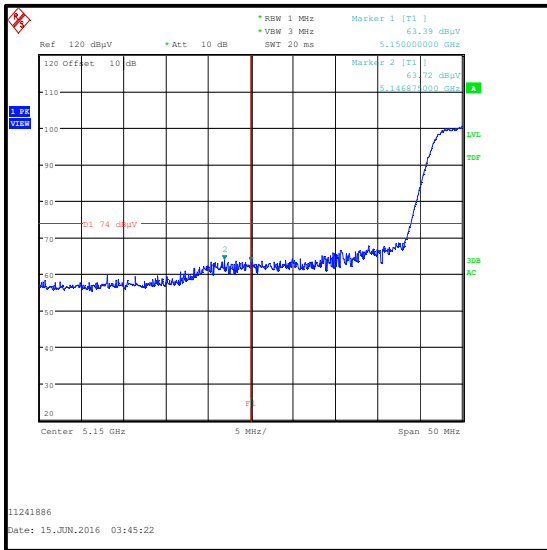

Lower Band Edge Peak Measurement

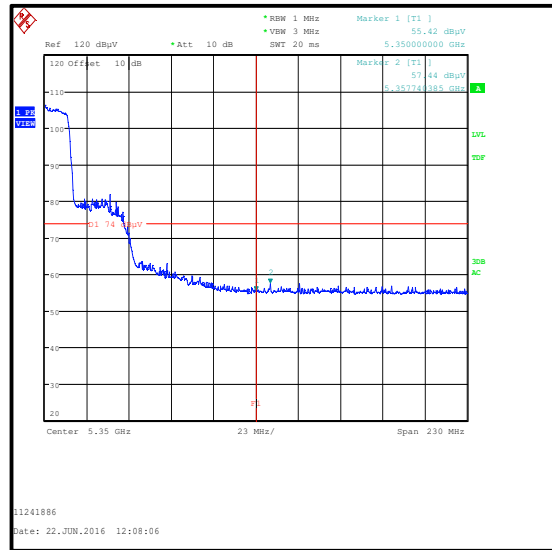

Upper Band Edge Peak Measurement

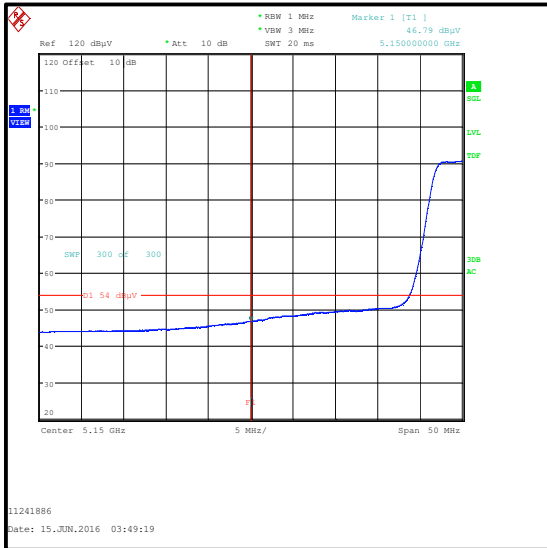

Lower Band Edge Average Measurement

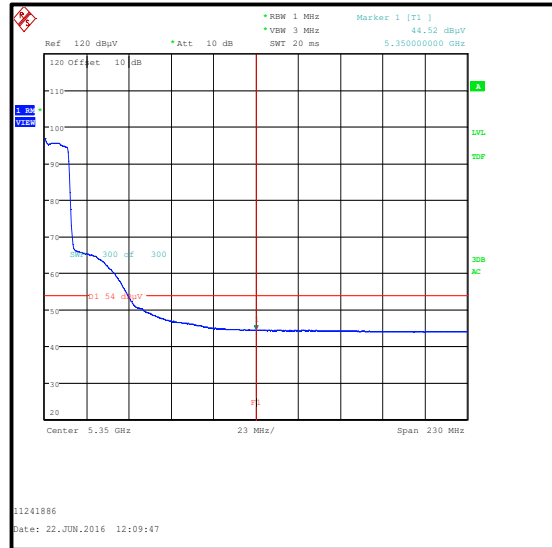

Upper Band Edge Average Measurement

Transmitter Band Edge Radiated Emissions (5.15-5.25 GHz band operation) (continued)**Results: 802.11ac / 80 MHz / BPSK / MCS0 / Port 1 / SISO / Peak**

Frequency (MHz)	Level (dB μ V/m)	Limit (dB μ V/m)	Margin (dB)	Result
5146.955	60.2	74.0	13.8	Complied
5150	58.7	74.0	15.3	Complied
5350	56.0	74.0	18.0	Complied
5375.433	57.4	74.0	16.6	Complied

Results: 802.11ac / 80 MHz / BPSK / MCS0 / Port 1 / SISO / Average

Frequency (MHz)	Level (dB μ V/m)	Duty Cycle correction (dB)	Corrected Level (dB μ V/m)	Limit (dB μ V/m)	Margin (dB)	Result
5150	46.8	0.2	47.0	54.0	7.0	Complied
5350	45.2	0.2	45.4	54.0	8.6	Complied

Transmitter Band Edge Radiated Emissions (5.15-5.25 GHz band operation) (continued)

Results: 802.11ac / 80 MHz / BPSK / MCS0 / Port 1 / SISO

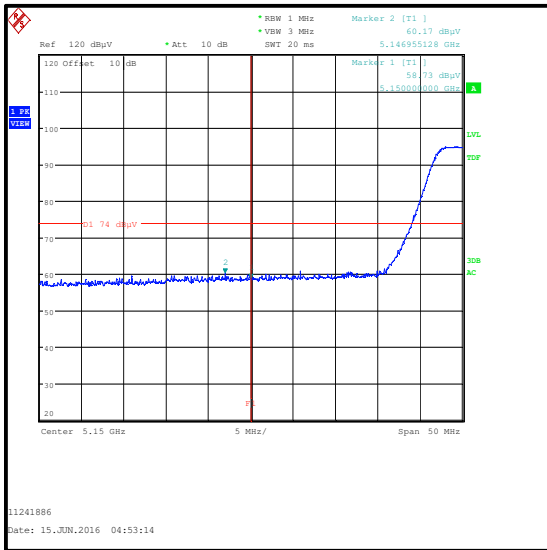

Lower Band Edge Peak Measurement

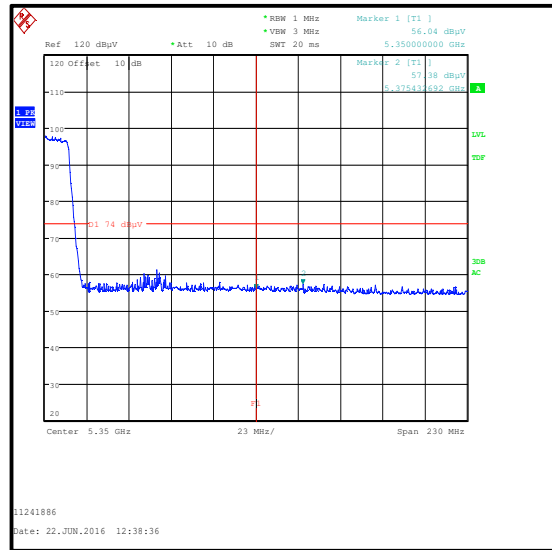

Upper Band Edge Peak Measurement

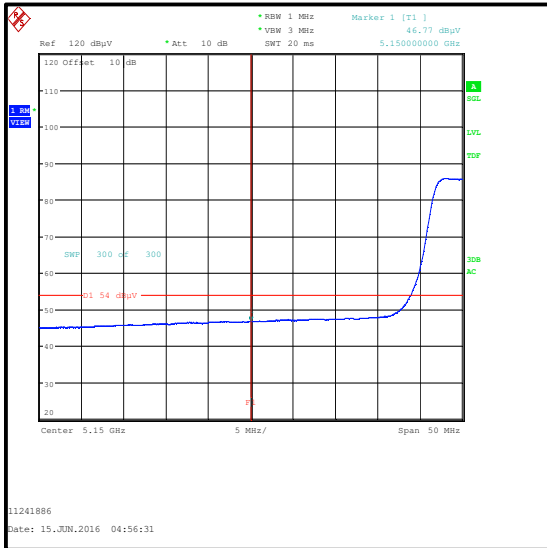

Lower Band Edge Average Measurement

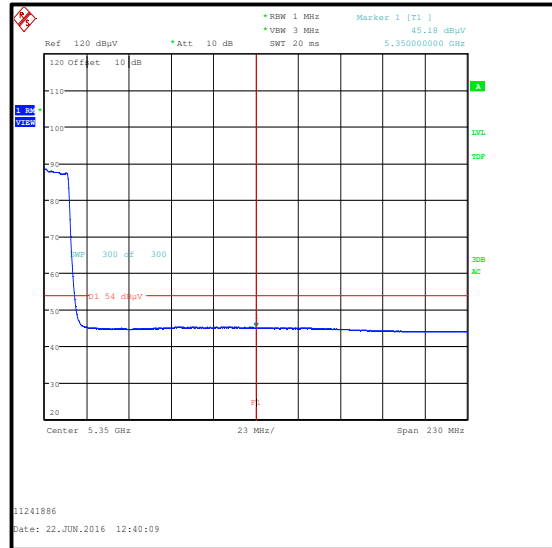

Upper Band Edge Average Measurement

Transmitter Band Edge Radiated Emissions (5.15-5.25 GHz band operation) (continued)**Results: 802.11n / 20 MHz / BPSK / MCS0 / MIMO / Peak**

Frequency (MHz)	Level (dB μ V/m)	Limit (dB μ V/m)	Margin (dB)	Result
5145.833	65.8	74.0	18.2	Complied
5150	61.1	74.0	12.9	Complied
5350	55.3	74.0	18.7	Complied
5362.163	56.9	74.0	17.1	Complied

Results: 802.11n / 20 MHz / BPSK / MCS0 / MIMO / Average

Frequency (MHz)	Level (dB μ V/m)	Limit (dB μ V/m)	Margin (dB)	Result
5150	47.1	54.0	6.9	Complied
5350	44.5	54.0	9.5	Complied

Transmitter Band Edge Radiated Emissions (5.15-5.25 GHz band operation) (continued)

Results: 802.11n / 20 MHz / BPSK / MCS0 / MIMO

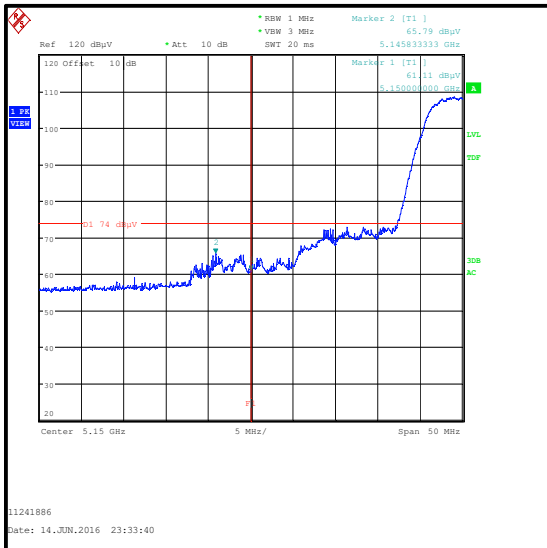

Lower Band Edge Peak Measurement

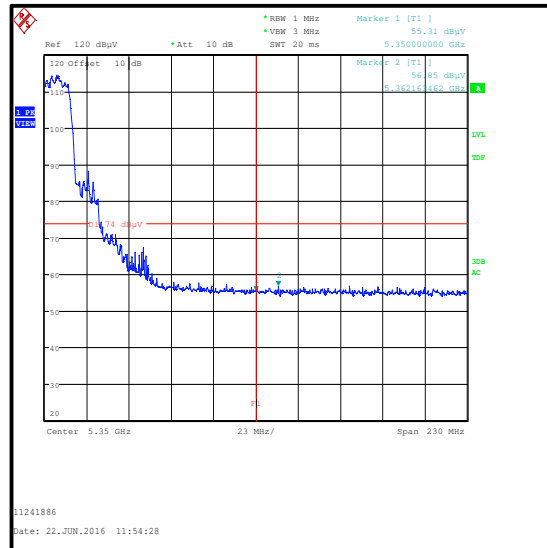

Upper Band Edge Peak Measurement

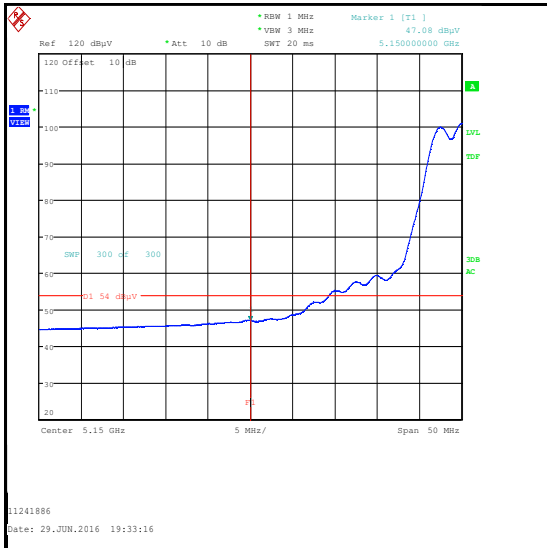

Lower Band Edge Average Measurement



Upper Band Edge Average Measurement

Transmitter Band Edge Radiated Emissions (5.15-5.25 GHz band operation) (continued)**Results: 802.11n / 40 MHz / BPSK / MCS0 / MIMO / Peak**

Frequency (MHz)	Level (dB μ V/m)	Limit (dB μ V/m)	Margin (dB)	Result
5150	63.6	74.0	10.4	Complied
5350	56.3	74.0	17.7	Complied
5375.433	57.4	74.0	16.6	Complied

Results: 802.11n / 40 MHz / BPSK / MCS0 / MIMO / Average

Frequency (MHz)	Level (dB μ V/m)	Duty Cycle correction (dB)	Corrected Level (dB μ V/m)	Limit (dB μ V/m)	Margin (dB)	Result
5150	48.7	0.1	48.8	54.0	5.2	Complied
5350	45.4	0.1	45.5	54.0	8.5	Complied

Transmitter Band Edge Radiated Emissions (5.15-5.25 GHz band operation) (continued)

Results: 802.11n / 40 MHz / BPSK / MCS0 / MIMO / MCS0

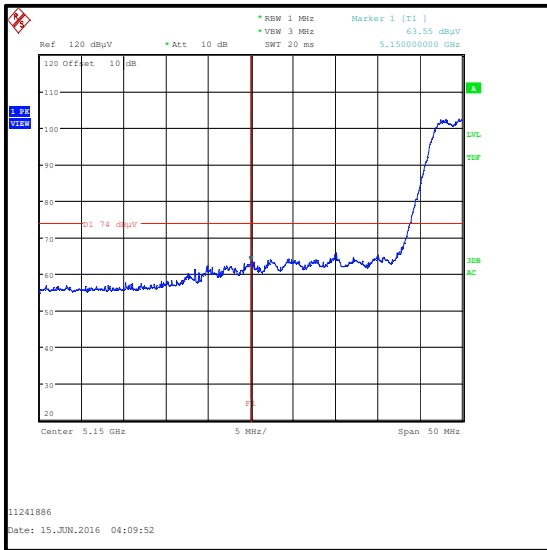

Lower Band Edge Peak Measurement

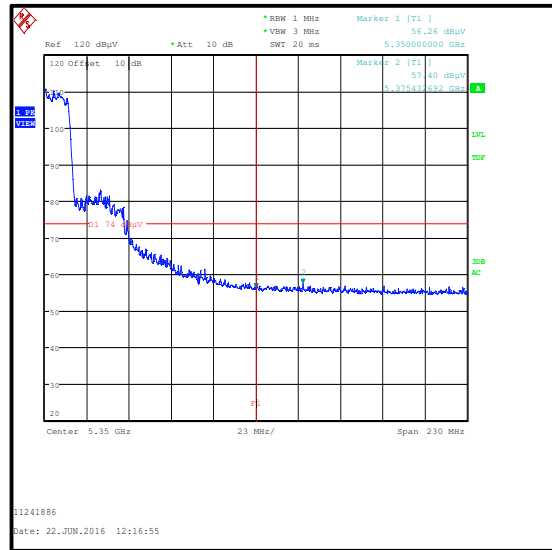

Upper Band Edge Peak Measurement



Lower Band Edge Average Measurement

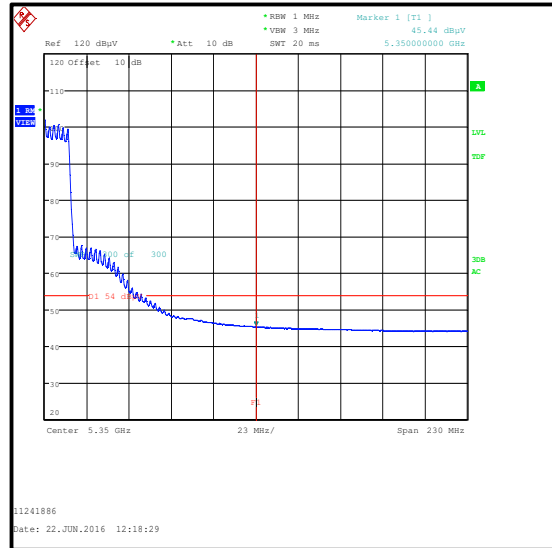

Upper Band Edge Average Measurement

Transmitter Band Edge Radiated Emissions (5.15-5.25 GHz band operation) (continued)**Results: 802.11ac / 80 MHz / BPSK / MCS0x1 / MIMO / Peak**

Frequency (MHz)	Level (dB μ V/m)	Limit (dB μ V/m)	Margin (dB)	Result
5146.715	63.7	74.0	10.3	Complied
5150	60.2	74.0	13.8	Complied
5350	57.1	74.0	16.9	Complied
5352.949	58.5	74.0	15.5	Complied

Results: 802.11ac / 80 MHz / BPSK / MCS0x1 / MIMO / Average

Frequency (MHz)	Level (dB μ V/m)	Duty Cycle correction (dB)	Corrected Level (dB μ V/m)	Limit (dB μ V/m)	Margin (dB)	Result
5148.878	50.5	0.2	50.7	54.0	3.3	Complied
5150	48.4	0.2	45.6	54.0	5.4	Complied
5350	46.8	0.2	47.0	54.0	7.0	Complied

Transmitter Band Edge Radiated Emissions (5.15-5.25 GHz band operation) (continued)

Results: 802.11ac / 80 MHz / BPSK / MCS0x1 / MIMO

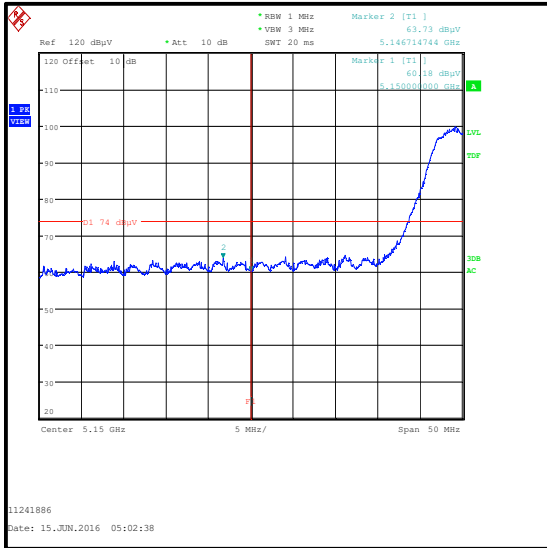

Lower Band Edge Peak Measurement

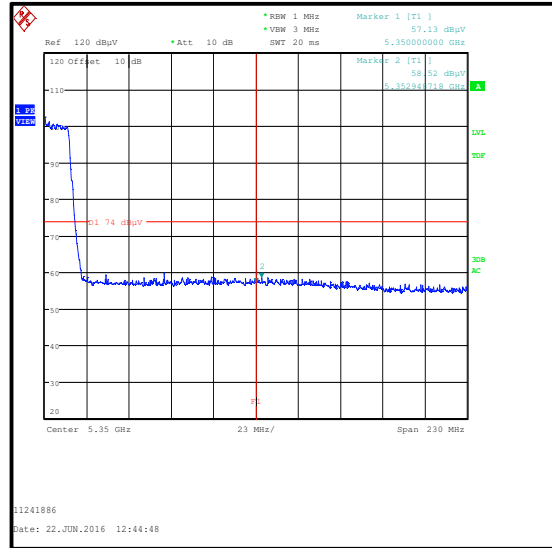

Upper Band Edge Peak Measurement

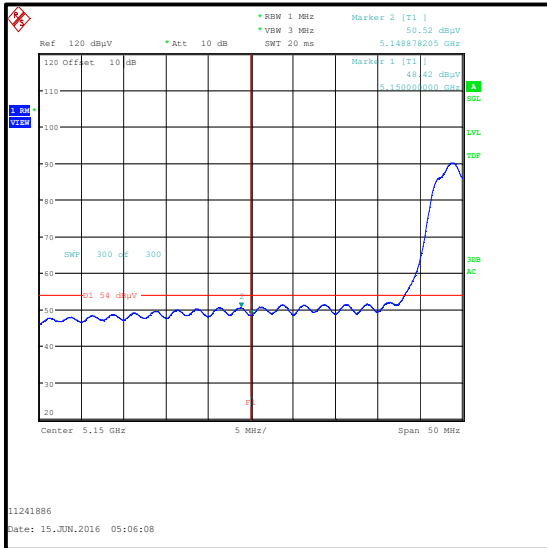

Lower Band Edge Average Measurement



Upper Band Edge Average Measurement

Transmitter Band Edge Radiated Emissions (5.25-5.35 GHz band)**Test Summary:**

Test Engineers:	Nick Steele & David Doyle	Test Dates:	15 June 2016 & 22 June 2016
Test Sample Serial Number:	C7CRR00BHCPX		

FCC Reference:	Parts 15.407(b)(2),(7), 15.205 & 15.209(a)
Test Method Used:	ANSI C63.10 Section 6.10 & KDB 789033 II.G.

Environmental Conditions:

Temperature (°C):	24 to 27
Relative Humidity (%):	41 to 44

Note(s):

- The customer declared the following data rates to be used for all measurements as:
 - 802.11a – BPSK / 6 Mbps / Port 1
 - 802.11n HT20 SISO – BPSK / 6.5 Mbps / MCS0 / Port 1
 - 802.11n HT40 SISO - BPSK / 13.5 Mbps / MCS0 / Port 1
 - 802.11ac VHT80 SISO – BPSK / 29.3 Mbps / MCS0 / Port 1
 - 802.11n HT20 MIMO – BPSK / 6.5 Mbps / MCS0
 - 802.11n HT40 MIMO – BPSK / 29.3 Mbps / MCS0
 - 802.11ac VHT80 MIMO – BPSK / 29.3 Mbps / MCS0x1
- Lower band edge measurements were performed with the EUT transmitting on the bottom channel. Upper band edge measurements were performed with the EUT transmitting on the top channel.
- For transmitters operating in the 5.25-5.35 GHz band: all emissions outside of the 5.15-5.35 GHz band shall not exceed an EIRP of -27 dBm/MHz. However, there are restricted bands of operation below the lower band edge at 4.5-5.15 GHz and also above the upper band edge at 5.35-5.46 GHz therefore the provisions of FCC Part 15.205 apply. Tests were performed in these restricted bands of operation with the EUT transmitting on the bottom and top channels within 5.25-5.35 GHz band, the results are included in the transmitter 5.25-5.35 GHz band radiated spurious emissions section of this test report.
- Field strength measurements using peak and average detectors were performed in the restricted bands below 5.15 GHz and above 5.35 GHz. Field strength and EIRP results were found to be compliant with the restricted band limits and Part 15.407 out-of-band limits.
- For all average measurements of this section, 300 sweeps were used. This satisfies the requirement for the minimum number of sweep points, as stated in ANSI C63.10 Section 12.7.7.2 Method AD f). Power averaging was used.
- In accordance with KDB 789033 Section II.G.6.c) Method AD (vii), for average measurements, data rates where the EUT was transmitting <98% duty cycle, the duty cycle correction factor calculated in section 5.2.3 was added to the measured result.

Transmitter Band Edge Radiated Emissions (5.25-5.35 GHz band operation) (continued)**Results: 802.11a / 20 MHz / BPSK / 6 Mbps / Port 1 / Peak**

Frequency (MHz)	Level (dB μ V/m)	Limit (dB μ V/m)	Margin (dB)	Result
5107.981	56.1	74.0	17.9	Complied
5150	54.9	74.0	19.1	Complied
5350	57.7	74.0	16.3	Complied
5352.163	59.3	74.0	14.7	Complied

Results: 802.11a / 20 MHz / BPSK / 6 Mbps / Port 1 / Average

Frequency (MHz)	Level (dB μ V/m)	Limit (dB μ V/m)	Margin (dB)	Result
5150	43.5	54.0	10.5	Complied
5350	45.9	54.0	8.1	Complied

Transmitter Band Edge Radiated Emissions (5.25-5.35 GHz band operation) (continued)

Results: 802.11a / 20 MHz / BPSK / 6 Mbps / Port 1

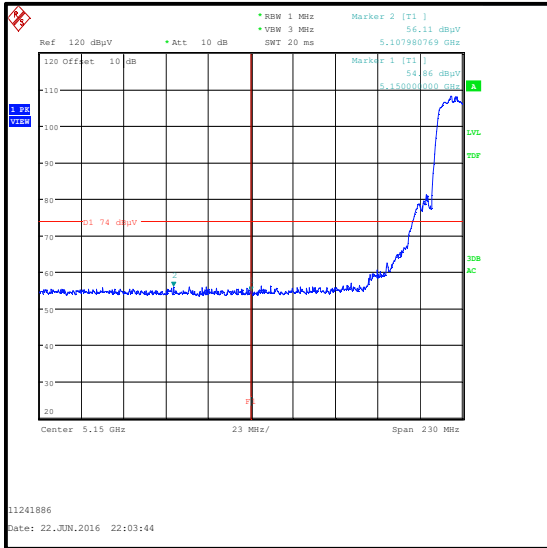

Lower Band Edge Peak Measurement

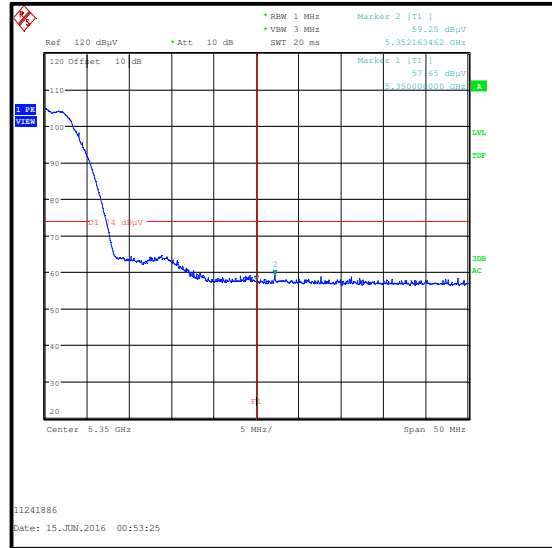

Upper Band Edge Peak Measurement



Lower Band Edge Measurement



Upper Band Edge Average Measurement

Transmitter Band Edge Radiated Emissions (5.25-5.35 GHz band operation) (continued)**Results: 802.11n / 20 MHz / BPSK / MCS0 / Port 1 / SISO / Peak**

Frequency (MHz)	Level (dB μ V/m)	Limit (dB μ V/m)	Margin (dB)	Result
5129.359	56.0	74.0	18.0	Complied
5150	54.5	74.0	19.5	Complied
5350	56.9	74.0	17.1	Complied
5354.487	61.4	74.0	12.6	Complied

Results: 802.11n / 20 MHz / BPSK / MCS0 / Port 1 / SISO / Average

Frequency (MHz)	Level (dB μ V/m)	Limit (dB μ V/m)	Margin (dB)	Result
5150	43.4	54.0	10.6	Complied
5350	45.8	54.0	8.2	Complied

Transmitter Band Edge Radiated Emissions (5.25-5.35 GHz band operation) (continued)

Results: 802.11n / 20 MHz / BPSK / MCS0 / Port 1 / SISO

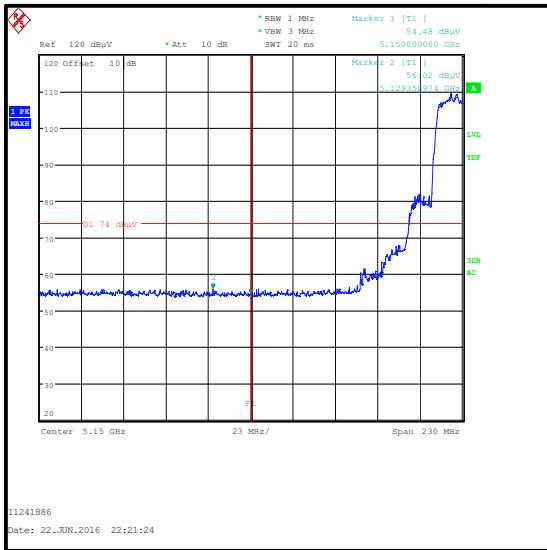

Lower Band Edge Peak Measurement

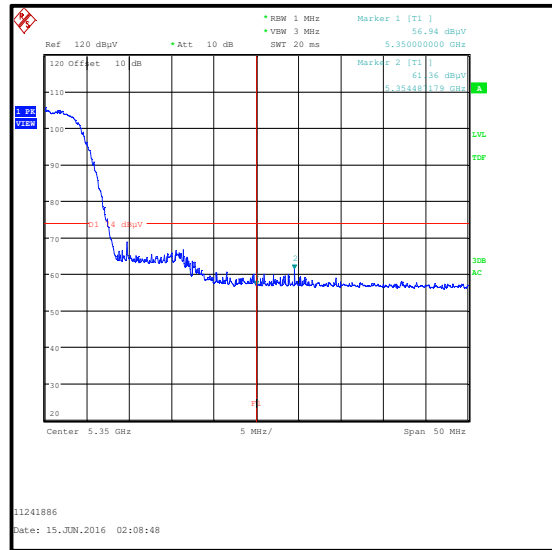

Upper Band Edge Peak Measurement

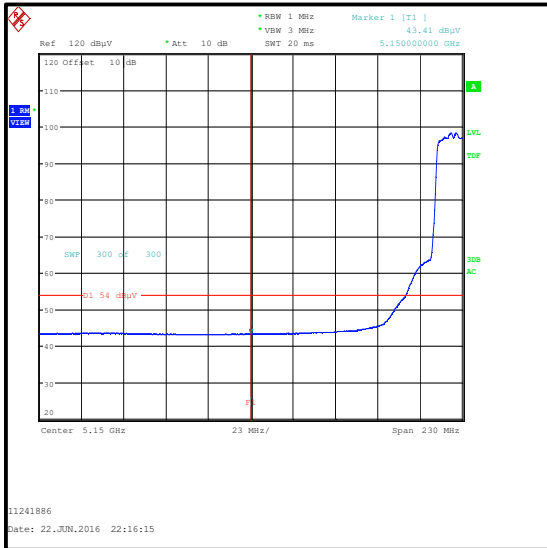

Lower Band Edge Average Measurement

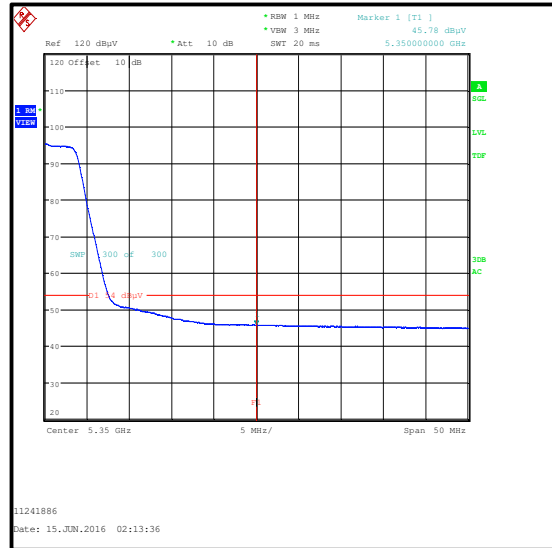

Upper Band Edge Average Measurement

Transmitter Band Edge Radiated Emissions (5.25-5.35 GHz band operation) (continued)**Results: 802.11n / 40 MHz / BPSK / MCS0 / Port 1 / SISO / Peak**

Frequency (MHz)	Level (dB μ V/m)	Limit (dB μ V/m)	Margin (dB)	Result
5074.071	56.1	74.0	17.9	Complied
5150	54.9	74.0	19.1	Complied
5350	57.1	74.0	16.9	Complied
5352.724	59.0	74.0	15.0	Complied

Results: 802.11n / 40 MHz / BPSK / MCS0 / Port 1 / SISO / Average

Frequency (MHz)	Level (dB μ V/m)	Duty Cycle correction (dB)	Corrected Level (dB μ V/m)	Limit (dB μ V/m)	Margin (dB)	Result
5150	43.8	0.1	43.9	54.0	10.1	Complied
5350	45.7	0.1	45.8	54.0	8.2	Complied

Transmitter Band Edge Radiated Emissions (5.25-5.35 GHz band operation) (continued)

Results: 802.11n / 40 MHz / BPSK / MCS0 / Port 1 / SISO 0

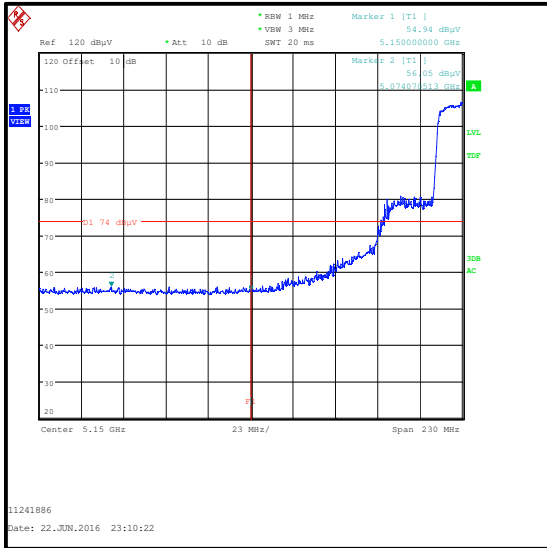

Lower Band Edge Peak Measurement

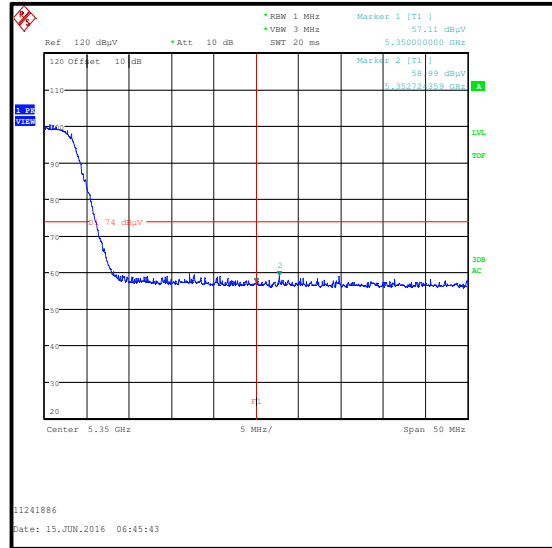

Upper Band Edge Peak Measurement

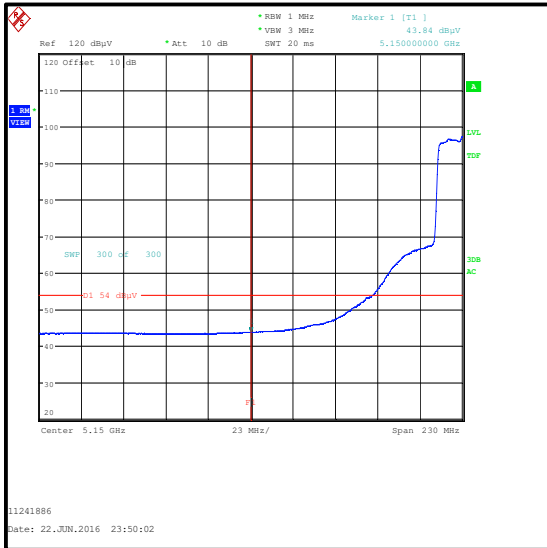

Lower Band Edge Average Measurement



Upper Band Edge Average Measurement

Transmitter Band Edge Radiated Emissions (5.25-5.35 GHz band operation) (continued)**Results: 802.11ac / 80 MHz / BPSK / MCS0 / Port 1 / SISO / Peak**

Frequency (MHz)	Level (dB μ V/m)	Limit (dB μ V/m)	Margin (dB)	Result
5096.554	57.3	74.0	16.7	Complied
5150	54.8	74.0	19.2	Complied
5350	56.8	74.0	17.2	Complied
5354.087	59.2	74.0	14.8	Complied

Results: 802.11ac / 80 MHz / BPSK / MCS0 / Port 1 / SISO / Average

Frequency (MHz)	Level (dB μ V/m)	Duty Cycle correction (dB)	Corrected Level (dB μ V/m)	Limit (dB μ V/m)	Margin (dB)	Result
5150	44.1	0.2	44.3	54.0	9.7	Complied
5350	45.6	0.2	45.8	54.0	8.2	Complied

Transmitter Band Edge Radiated Emissions (5.25-5.35 GHz band operation) (continued)

Results: 802.11ac / 80 MHz / BPSK / MCS0 / Port 1 / SISO

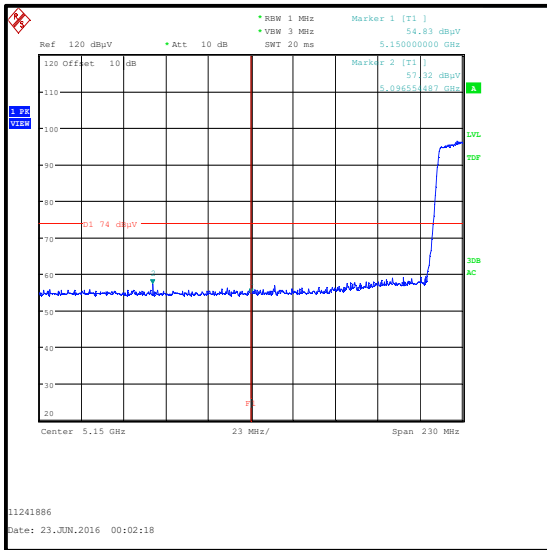

Lower Band Edge Peak Measurement

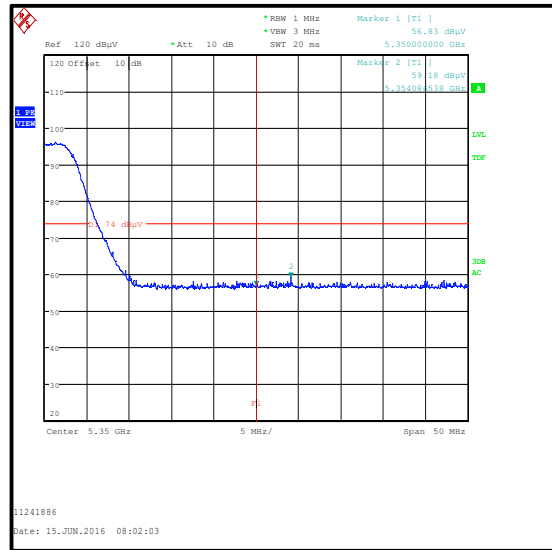

Upper Band Edge Peak Measurement

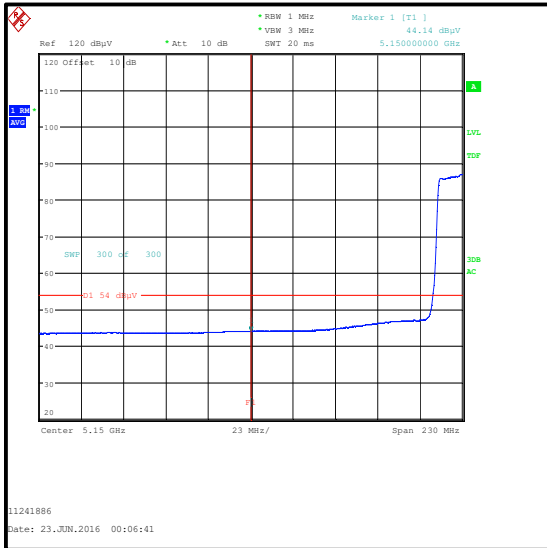

Lower Band Edge Average Measurement



Upper Band Edge Average Measurement

Transmitter Band Edge Radiated Emissions (5.25-5.35 GHz band operation) (continued)**Results: 802.11n / 20 MHz / BPSK / MCS0 / MIMO / Peak**

Frequency (MHz)	Level (dB μ V/m)	Limit (dB μ V/m)	Margin (dB)	Result
5056.010	56.8	74.0	17.2	Complied
5150	54.7	74.0	19.3	Complied
5350	60.2	74.0	13.8	Complied
5355.128	62.9	74.0	11.1	Complied

Results: 802.11n / 20 MHz / BPSK / MCS0 / MIMO / Average

Frequency (MHz)	Level (dB μ V/m)	Limit (dB μ V/m)	Margin (dB)	Result
5150	43.8	54.0	10.2	Complied
5350	47.3	54.0	6.7	Complied

Transmitter Band Edge Radiated Emissions (5.25-5.35 GHz band operation) (continued)

Results: 802.11n / 20 MHz / BPSK / MCS0 / MIMO

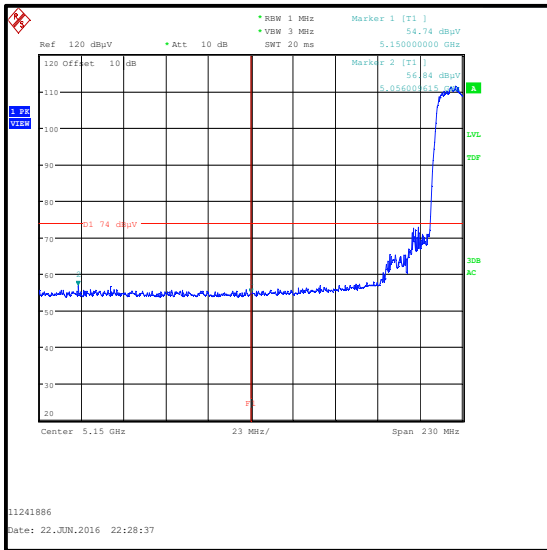

Lower Band Edge Peak Measurement

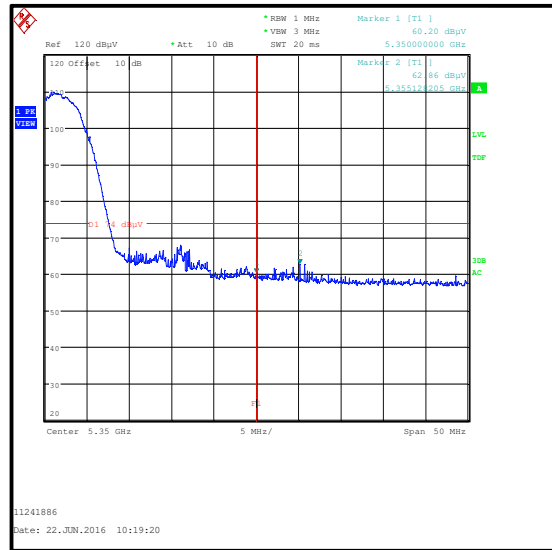

Upper Band Edge Peak Measurement

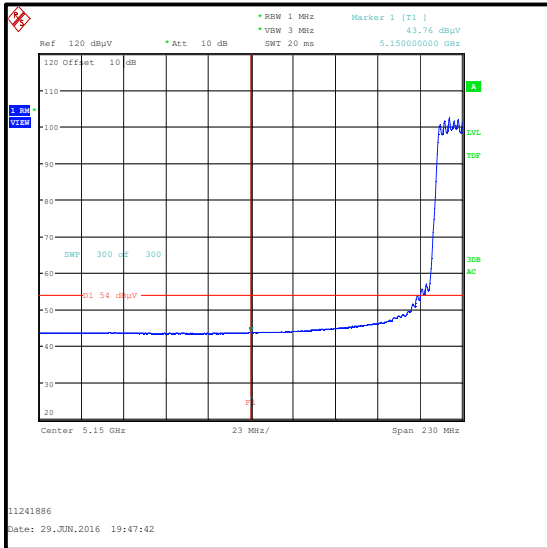

Lower Band Edge Average Measurement

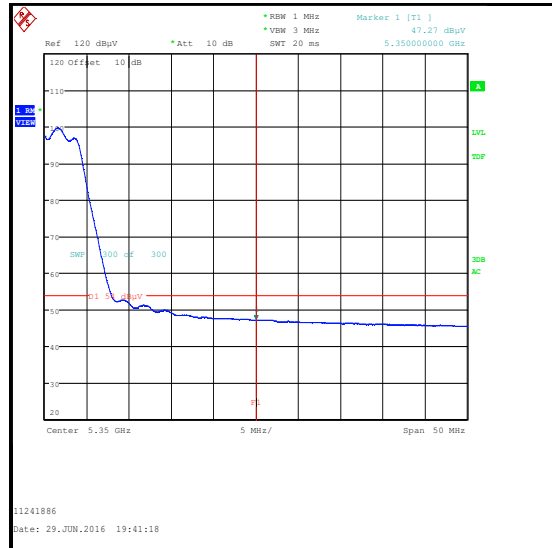

Upper Band Edge Average Measurement

Transmitter Band Edge Radiated Emissions (5.25-5.35 GHz band operation) (continued)**Results: 802.11n / 40 MHz / BPSK / MCS0 / MIMO / Peak**

Frequency (MHz)	Level (dB μ V/m)	Limit (dB μ V/m)	Margin (dB)	Result
5041.635	56.7	74.0	17.3	Complied
5150	54.8	74.0	19.2	Complied
5350	57.8	74.0	16.5	Complied
5353.766	61.7	74.0	12.3	Complied

Results: 802.11n / 40 MHz / BPSK / MCS0 / MIMO / Average

Frequency (MHz)	Level (dB μ V/m)	Duty Cycle correction (dB)	Corrected Level (dB μ V/m)	Limit (dB μ V/m)	Margin (dB)	Result
5150	44.2	0.1	44.3	54.0	9.7	Complied
5350	46.8	0.1	46.9	54.0	7.1	Complied

Transmitter Band Edge Radiated Emissions (5.25-5.35 GHz band operation) (continued)

Results: 802.11n / 40 MHz / BPSK / MCS0 / MIMO

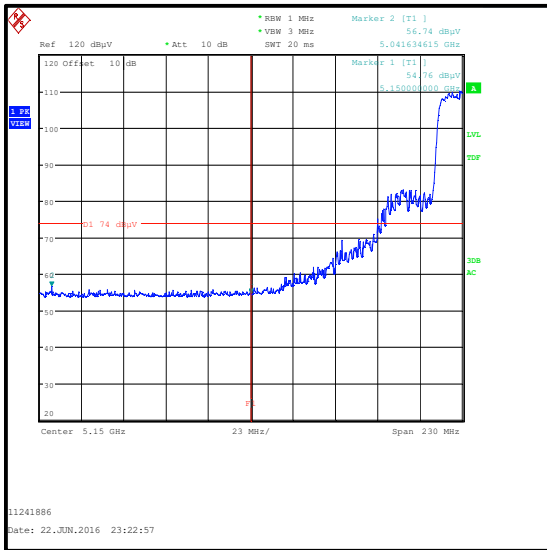

Lower Band Edge Peak Measurement

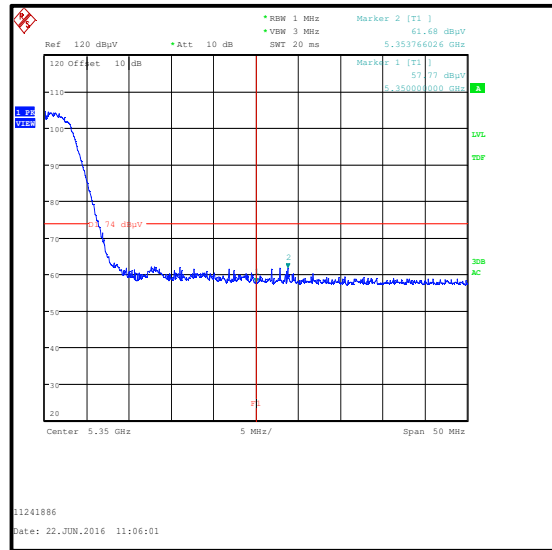

Upper Band Edge Peak Measurement

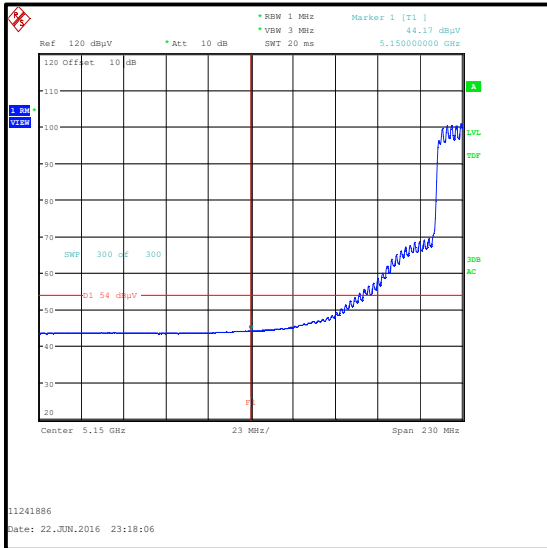

Lower Band Edge Average Measurement



Upper Band Edge Average Measurement

Transmitter Band Edge Radiated Emissions (5.25-5.35 GHz band operation) (continued)**Results: 802.11ac / 80 MHz / BPSK / MCS0x1 / MIMO / Peak**

Frequency (MHz)	Level (dB μ V/m)	Limit (dB μ V/m)	Margin (dB)	Result
5146.683	56.8	74.0	17.2	Complied
5150	55.5	74.0	18.5	Complied
5350	57.7	74.0	16.3	Complied
5351.442	58.9	74.0	15.1	Complied

Results: 802.11ac / 80 MHz / BPSK / MCS0x1 / MIMO / Average

Frequency (MHz)	Level (dB μ V/m)	Duty Cycle correction (dB)	Corrected Level (dB μ V/m)	Limit (dB μ V/m)	Margin (dB)	Result
5150	44.7	0.2	44.9	54.0	9.1	Complied
5350	46.3	0.2	46.5	54.0	7.5	Complied

Transmitter Band Edge Radiated Emissions (5.25-5.35 GHz band operation) (continued)

Results: 802.11ac / 80 MHz / BPSK / MCS0x1 / MIMO

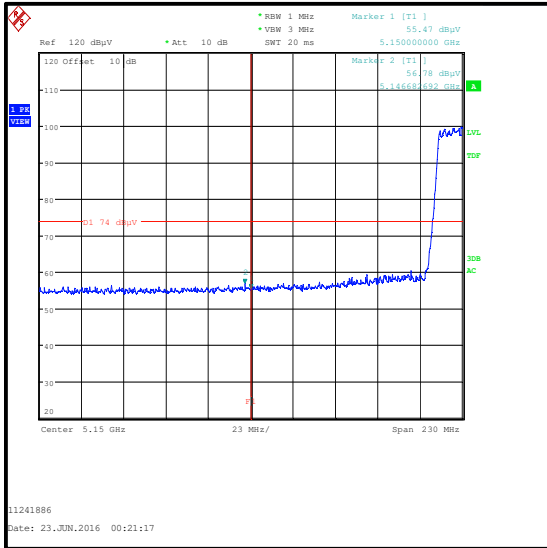

Lower Band Edge Peak Measurement

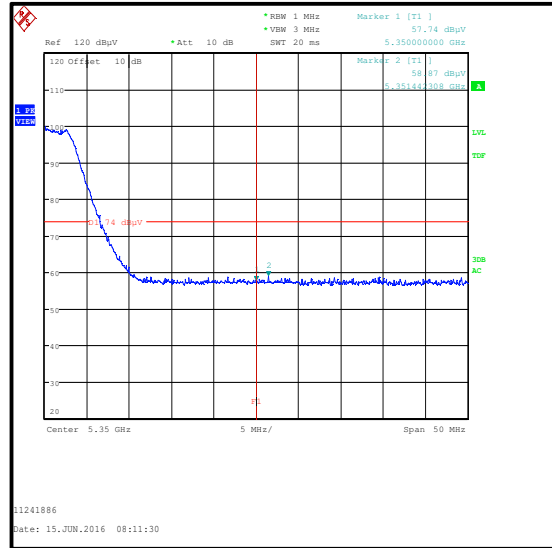

Upper Band Edge Peak Measurement



Lower Band Edge Average Measurement

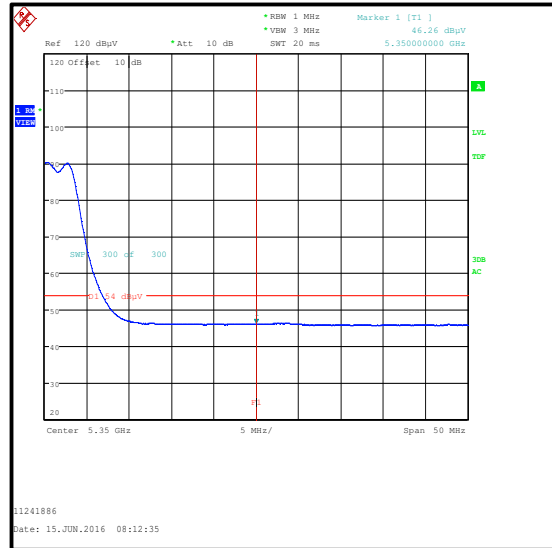

Upper Band Edge Average Measurement

Transmitter Band Edge Radiated Emissions (5.47-5.725 GHz band)**Test Summary:**

Test Engineers:	David Doyle, Andrew Edwards & Sandeep Bharat	Test Dates:	15 June 2016 to 07 July 2016
Test Sample Serial Number:	C7CRR00BHCPX		

FCC Reference:	Parts 15.407(b)(3),(7), 15.205 & 15.209(a)
Test Method Used:	ANSI C63.10 Section 6.10 & KDB 789033 II.G.

Environmental Conditions:

Temperature (°C):	24 to 28
Relative Humidity (%):	39 to 43

Note(s):

1. The customer declared the following data rates to be used for all measurements as:
 - 802.11a – BPSK / 6 Mbps / Port 1
 - 802.11n HT20 SISO – BPSK / 6.5 Mbps / MCS0 / Port 1
 - 802.11n HT40 SISO - BPSK / 13.5 Mbps / MCS0 / Port 1
 - 802.11ac VHT80 SISO – BPSK / 29.3 Mbps / MCS0 / Port 1
 - 802.11n HT20 MIMO – BPSK / 6.5 Mbps / MCS0
 - 802.11n HT40 MIMO – BPSK / 29.3 Mbps / MCS0
 - 802.11ac VHT80 MIMO – BPSK / 29.3 Mbps / MCS0x1
2. Lower band edge measurements were performed with the EUT transmitting on the bottom channel. Upper band edge measurements were performed with the EUT transmitting on the top channel.
3. For transmitters operating in the 5.47-5.725 GHz band: all emissions outside of the 5.47-5.725 GHz band shall not exceed an EIRP of -27 dBm/MHz. However, there are restricted bands of operation below the lower band edge at 4.5-5.15 GHz and also at 5.35-5.46 GHz therefore the provisions of FCC Part 15.205 apply. Tests were performed in these restricted bands of operation with the EUT transmitting on the bottom and top channels within 5.47-5.725 GHz band, the results are included in the transmitter 5.725-5.85 GHz band radiated spurious emissions section of this test report.
4. For completeness, results are also shown as EIRP in dBm and also as field strength in dB μ V/m. Measured field strength was converted to EIRP in accordance with KDB 789033 II.G.2.d.(iii) using a conversion factor of 95.2.

Transmitter Band Edge Radiated Emissions (5.47-5.725 GHz band operation) (continued)

Results: 802.11a / 20 MHz / BPSK / 6 Mbps / Peak

Frequency (MHz)	Level (dBm)	Limit (dBm)	Margin (dB)	Result
5469.359	-37.1	-27.0	10.1	Complied
5470	-38.9	-27.0	11.9	Complied
5725	-37.8	-27.0	10.8	Complied
5725.240	-33.3	-27.0	6.3	Complied

Frequency (MHz)	Level (dBμV/m)	Limit (dBμV/m)	Margin (dB)	Result
5469.359	58.1	68.2	10.1	Complied
5470	56.3	68.2	11.9	Complied
5725	57.4	68.2	10.8	Complied
5725.240	61.9	68.2	6.3	Complied



Lower Band Edge Measurement

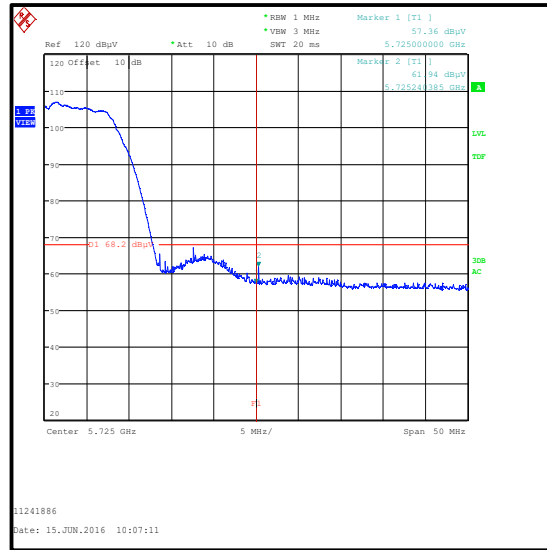

Upper Band Edge Measurement

Transmitter Band Edge Radiated Emissions (5.47-5.725 GHz band operation) (continued)

Results: 802.11n / 20 MHz / BPSK / MCS0 / Port 1 / SISO / Peak

Frequency (MHz)	Level (dBm)	Limit (dBm)	Margin (dB)	Result
5467.756	-36.7	-27.0	9.7	Complied
5470	-38.4	-27.0	11.4	Complied
5725	-33.6	-27.0	6.6	Complied
5725.321	-31.5	-27.0	4.5	Complied

Frequency (MHz)	Level (dBμV/m)	Limit (dBμV/m)	Margin (dB)	Result
5467.756	58.5	68.2	9.7	Complied
5470	56.8	68.2	11.4	Complied
5725	61.6	68.2	6.6	Complied
5725.321	63.7	68.2	4.5	Complied

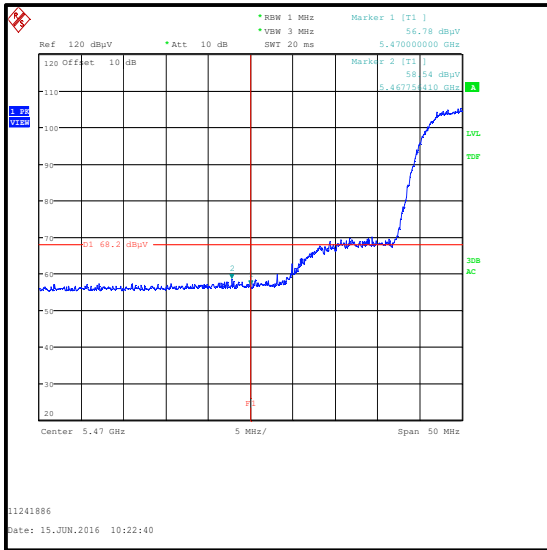

Lower Band Edge Measurement

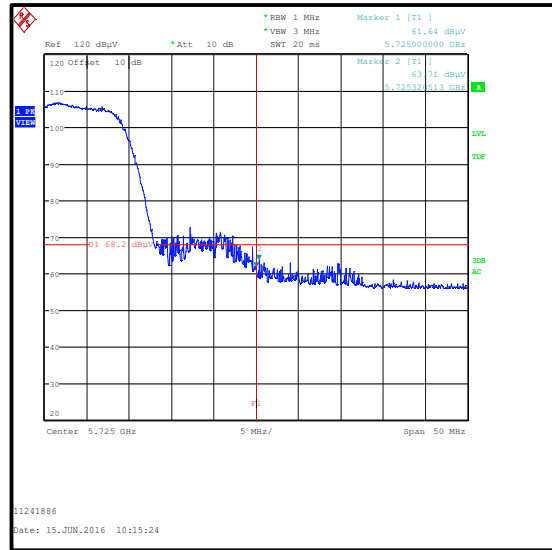

Upper Band Edge Measurement

Transmitter Band Edge Radiated Emissions (5.47-5.725 GHz band operation) (continued)

Results: 802.11n / 40 MHz / BPSK / MCS0 / Port 1 / SISO / Peak

Frequency (MHz)	Level (dBm)	Limit (dBm)	Margin (dB)	Result
5470	-31.8	-27.0	4.8	Complied
5725	-34.5	-27.0	7.5	Complied
5731.090	-32.8	-27.0	5.8	Complied

Frequency (MHz)	Level (dBμV/m)	Limit (dBμV/m)	Margin (dB)	Result
5470	63.4	68.2	4.8	Complied
5725	60.7	68.2	7.5	Complied
5731.090	62.4	68.2	5.8	Complied

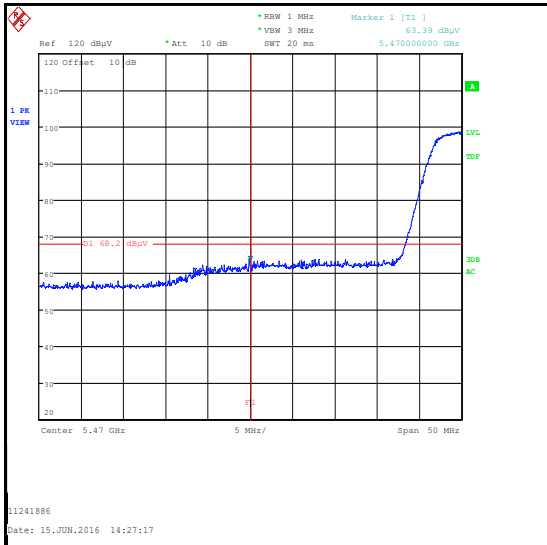

Lower Band Edge Measurement

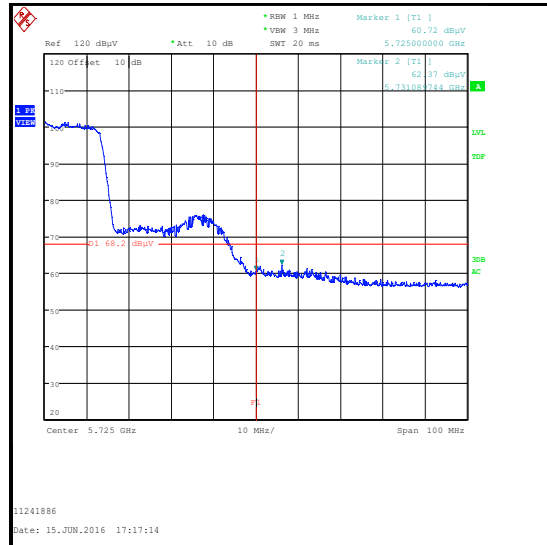

Upper Band Edge Measurement

Transmitter Band Edge Radiated Emissions (5.47-5.725 GHz band operation) (continued)

Results: 802.11ac / 80 MHz / BPSK / MCS0 / Port 1 / SISO / Peak

Frequency (MHz)	Level (dBm)	Limit (dBm)	Margin (dB)	Result
5470	-34.7	-27.0	7.7	Complied
5725	-36.4	-27.0	9.4	Complied
5729.487	-35.9	-27.0	8.9	Complied

Frequency (MHz)	Level (dBμV/m)	Limit (dBμV/m)	Margin (dB)	Result
5470	60.5	68.2	7.7	Complied
5725	58.8	68.2	9.4	Complied
5729.487	59.3	68.2	8.9	Complied

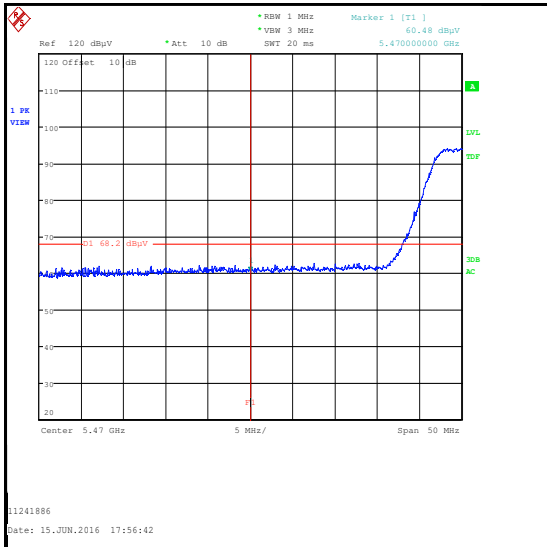

Lower Band Edge Measurement

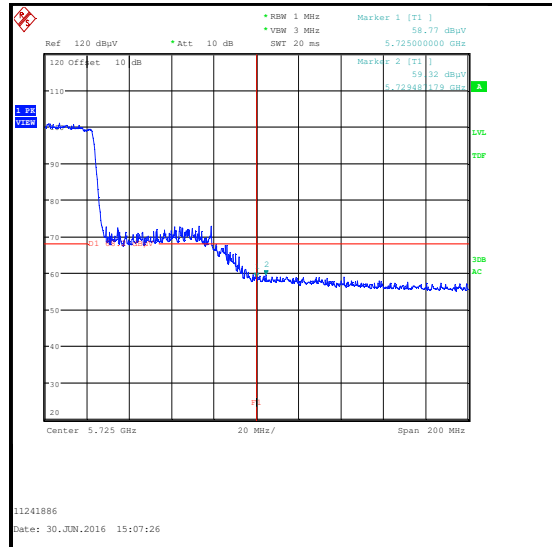

Upper Band Edge Measurement

Transmitter Band Edge Radiated Emissions (5.47-5.725 GHz band operation) (continued)

Results: 802.11n / 20 MHz / BPSK / MCS0 / MIMO / Peak

Frequency (MHz)	Level (dBm)	Limit (dBm)	Margin (dB)	Result
5466.714	-35.6	-27.0	8.6	Complied
5470	-36.7	-27.0	9.7	Complied
5725	-36.2	-27.0	9.2	Complied
5725.240	-31.1	-27.0	4.1	Complied

Frequency (MHz)	Level (dBμV/m)	Limit (dBμV/m)	Margin (dB)	Result
5466.714	59.6	68.2	8.6	Complied
5470	58.5	68.2	9.7	Complied
5725	59.0	68.2	9.2	Complied
5725.240	64.1	68.2	4.1	Complied

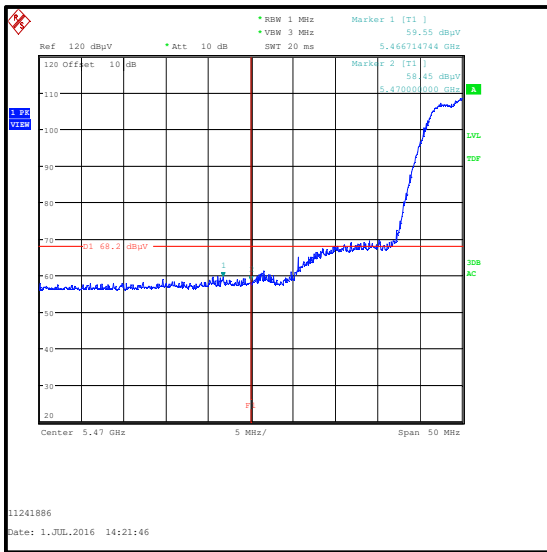

Lower Band Edge Measurement

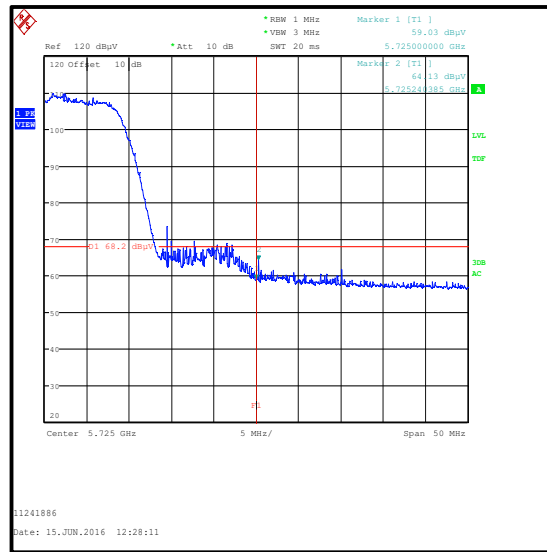

Upper Band Edge Measurement

Transmitter Band Edge Radiated Emissions (5.47-5.725 GHz band operation) (continued)

Results: 802.11n / 40 MHz / BPSK / MCS0 / MIMO / Peak

Frequency (MHz)	Level (dBm)	Limit (dBm)	Margin (dB)	Result
5468.558	-33.3	-27.0	6.3	Complied
5470	-35.3	-27.0	8.3	Complied
5725	-34.5	-27.0	7.5	Complied
5726.442	-31.9	-27.0	4.9	Complied

Frequency (MHz)	Level (dBμV/m)	Limit (dBμV/m)	Margin (dB)	Result
5468.558	61.9	68.2	6.3	Complied
5470	59.9	68.2	8.3	Complied
5725	60.7	68.2	7.5	Complied
5726.442	63.3	68.2	4.9	Complied

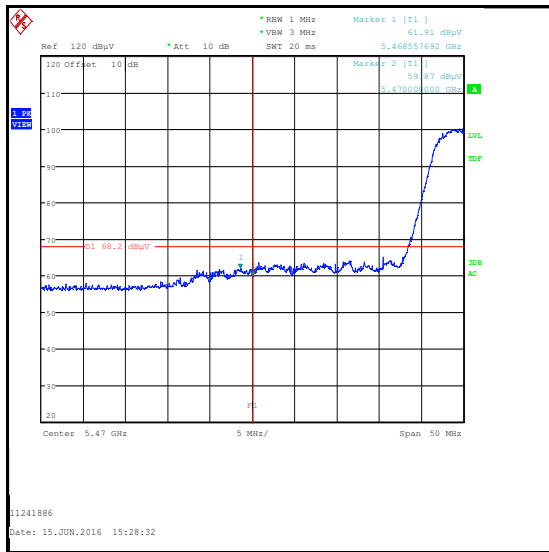

Lower Band Edge Measurement

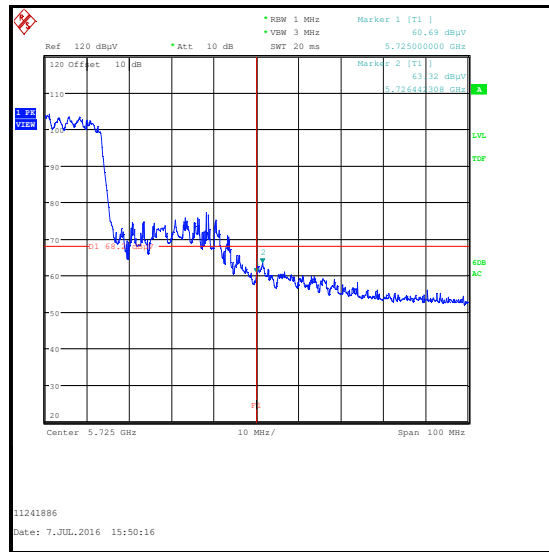

Upper Band Edge Measurement

Transmitter Band Edge Radiated Emissions (5.47-5.725 GHz band operation) (continued)

Results: 802.11ac / 80 MHz / BPSK / MCS0x1 / MIMO / Peak

Frequency (MHz)	Level (dBm)	Limit (dBm)	Margin (dB)	Result
5470	-37.0	-27.0	10.0	Complied
5725	-35.5	-27.0	8.5	Complied
5727.244	-33.2	-27.0	6.2	Complied

Frequency (MHz)	Level (dB μ V/m)	Limit (dB μ V/m)	Margin (dB)	Result
5470	58.2	68.2	10.0	Complied
5725	59.7	68.2	8.5	Complied
5727.244	62.0	68.2	6.2	Complied

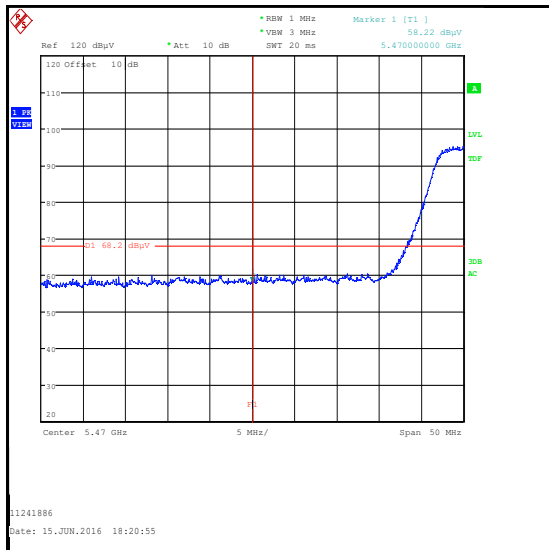

Lower Band Edge Measurement

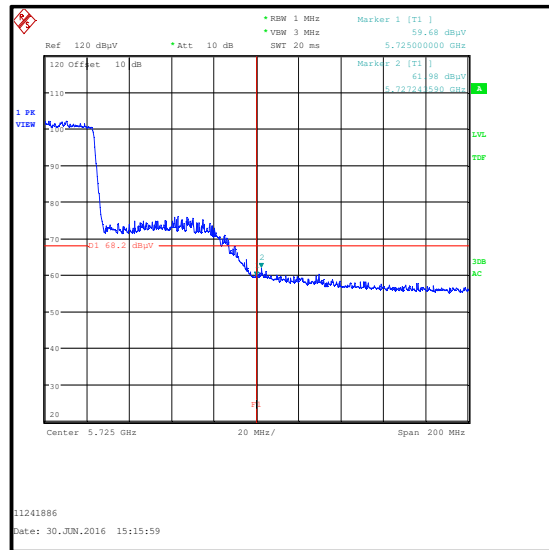

Upper Band Edge Measurement

Transmitter Band Edge Radiated Emissions (5.725-5.85 GHz band)**Test Summary:**

Test Engineer:	Andrew Edwards	Test Dates:	15 June 2016 & 16 June 2016
Test Sample Serial Number:	C7CRR00BHCPX		

FCC Reference:	Parts 15.407(b)(4)(i),(7), 15.205 & 15.209(a)
Test Method Used:	ANSI C63.10 Section 6.10 & KDB 789033 II.G.

Environmental Conditions:

Temperature (°C):	27 to 28
Relative Humidity (%):	38 to 43

Note(s):

1. The customer declared the following data rates to be used for all measurements as:
 - 802.11a – BPSK / 6 Mbps / Port 1
 - 802.11n HT20 SISO – BPSK / 6.5 Mbps / MCS0 / Port 1
 - 802.11n HT40 SISO - BPSK / 13.5 Mbps / MCS0 / Port 1
 - 802.11ac VHT80 SISO – BPSK / 29.3 Mbps / MCS0 / Port 1
 - 802.11n HT20 MIMO – BPSK / 6.5 Mbps / MCS0
 - 802.11n HT40 MIMO – BPSK / 29.3 Mbps / MCS0
 - 802.11ac VHT80 MIMO – BPSK / 29.3 Mbps / MCS0x1
2. Lower band edge measurements were performed with the EUT transmitting on the bottom channel. Upper band edge measurements were performed with the EUT transmitting on the top channel.
3. For completeness, results are also shown as EIRP in dBm and also as field strength in dB μ V/m. Measured field strength was converted to EIRP in accordance with KDB 789033 G.2.d)(iii) using a conversion factor of 95.2.

Transmitter Band Edge Radiated Emissions (5.725-5.85 GHz band operation) (continued)

Results: 802.11a / 20 MHz / BPSK / 6 Mbps / Port 1 / Peak

Frequency (MHz)	Level (dBm)	Limit (dBm/MHz)	Margin (dB)	Result
5640.705	-39.4	-27.0	12.4	Complied
5725	-17.6	27.0	44.6	Complied
5850	-25.8	27.0	52.8	Complied
5948.397	-37.8	-27.0	10.8	Complied

Frequency (MHz)	Level (dBμV/m)	Limit (dBμV/m)	Margin (dB)	Result
5640.705	55.8	68.2	12.4	Complied
5725	77.6	122.2	44.6	Complied
5850	69.4	122.2	52.8	Complied
5948.397	57.4	68.2	10.8	Complied

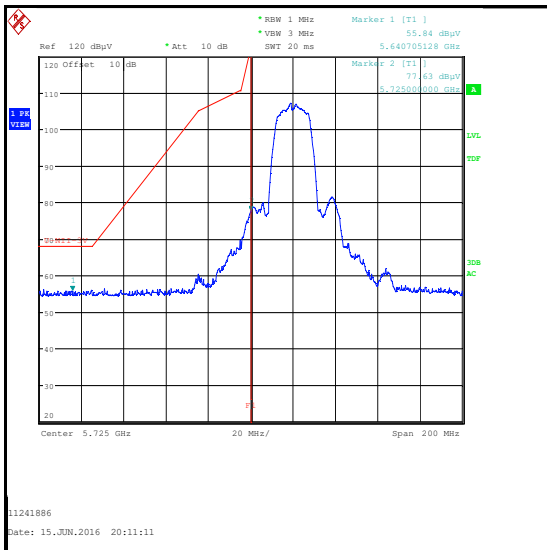

Lower Band Edge Measurement

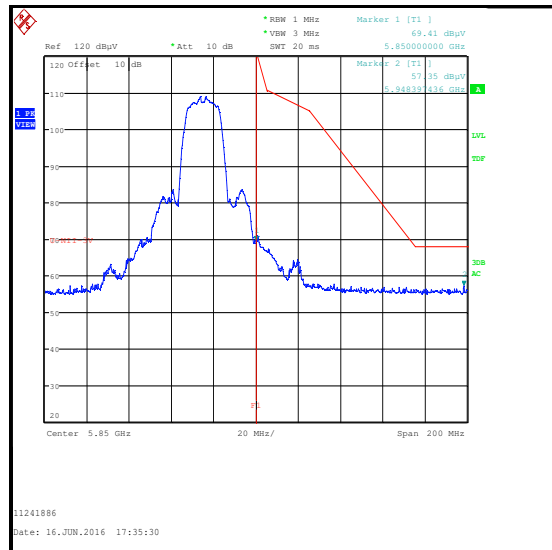

Upper Band Edge Measurement

Transmitter Band Edge Radiated Emissions (5.725-5.85 GHz band operation) (continued)

Results: 802.11n / 20 MHz / BPSK / MCS0 / Port 1 / SISO / Peak

Frequency (MHz)	Level (dBm)	Limit (dBm/MHz)	Margin (dB)	Result
5635.256	-38.8	-27.0	11.8	Complied
5725	-13.9	27.0	40.9	Complied
5850	-21.7	27.0	48.7	Complied
5927.244	-37.4	-27.0	10.4	Complied

Frequency (MHz)	Level (dBμV/m)	Limit (dBμV/m)	Margin (dB)	Result
5635.256	56.4	68.2	11.8	Complied
5725	81.3	122.2	40.9	Complied
5850	73.5	122.2	48.7	Complied
5927.244	57.8	68.2	10.4	Complied

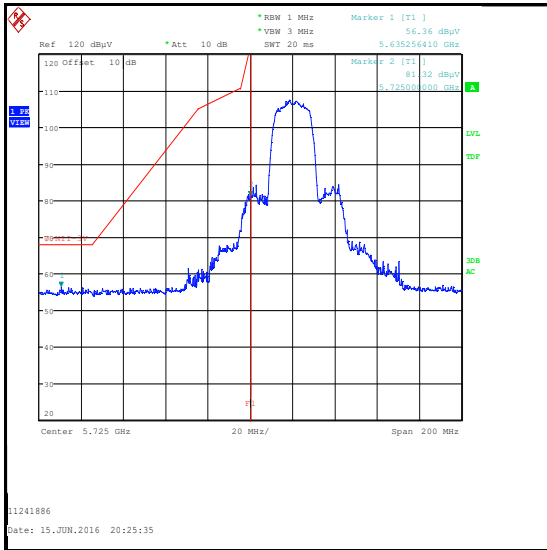

Lower Band Edge Measurement

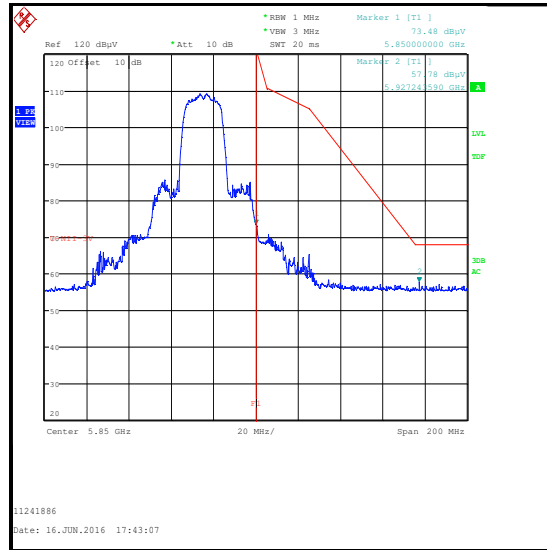

Upper Band Edge Measurement

Transmitter Band Edge Radiated Emissions (5.725-5.85 GHz band operation) (continued)

Results: 802.11n / 40 MHz / BPSK / MCS0 / Port 1 / SISO / Peak

Frequency (MHz)	Level (dBm)	Limit (dBm/MHz)	Margin (dB)	Result
5644.231	-38.7	-27.0	11.7	Complied
5725	-20.2	27.0	47.2	Complied
5850	-31.2	27.0	58.2	Complied
5936.218	-37.4	-27.0	10.4	Complied

Frequency (MHz)	Level (dBμV/m)	Limit (dBμV/m)	Margin (dB)	Result
5644.231	56.5	68.2	11.7	Complied
5725	75.0	122.2	47.2	Complied
5850	64.0	122.2	58.2	Complied
5936.218	57.8	68.2	10.4	Complied

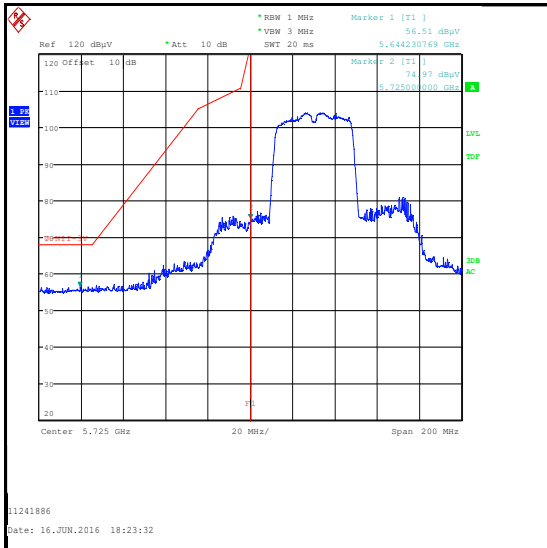

Lower Band Edge Measurement

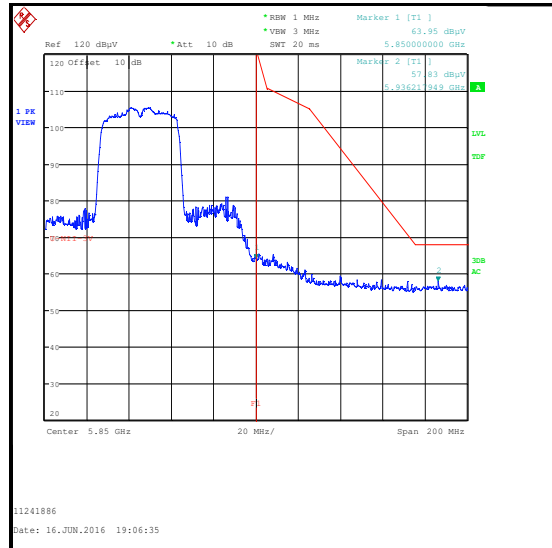

Upper Band Edge Measurement

Transmitter Band Edge Radiated Emissions (5.725-5.85 GHz band operation) (continued)

Results: 802.11ac / 80 MHz / BPSK / MCS0 / Port 1 / SISO / Peak

Frequency (MHz)	Level (dBm)	Limit (dBm/MHz)	Margin (dB)	Result
5634.295	-36.9	-27.0	9.9	Complied
5725	-31.0	27.0	58.0	Complied
5850	-23.9	27.0	50.9	Complied
5940.705	-36.5	-27.0	9.5	Complied

Frequency (MHz)	Level (dBμV/m)	Limit (dBμV/m)	Margin (dB)	Result
5634.295	58.3	68.2	9.9	Complied
5725	64.2	122.2	58.0	Complied
5850	71.3	122.2	50.9	Complied
5940.705	58.7	68.2	9.5	Complied

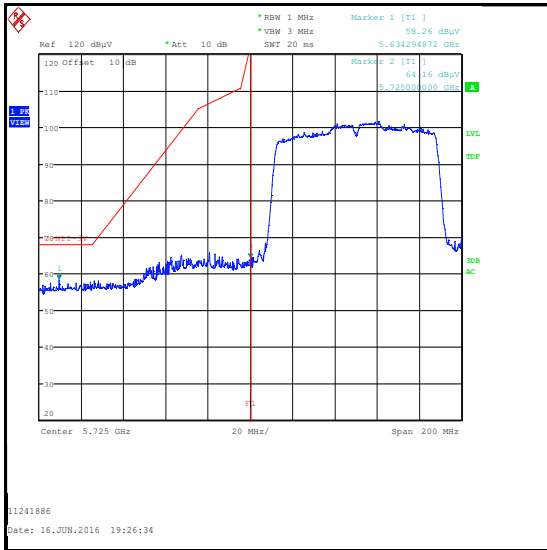

Lower Band Edge Measurement



Upper Band Edge Measurement

Transmitter Band Edge Radiated Emissions (5.725-5.85 GHz band operation) (continued)

Results: 802.11n / 20 MHz / BPSK / MCS0 / MIMO / Peak

Frequency (MHz)	Level (dBm)	Limit (dBm/MHz)	Margin (dB)	Result
5634.936	-38.4	-27.0	11.4	Complied
5725	-10.8	27.0	37.8	Complied
5850	-17.9	27.0	44.9	Complied
5942.308	-38.0	-27.0	11.0	Complied

Frequency (MHz)	Level (dBμV/m)	Limit (dBμV/m)	Margin (dB)	Result
5634.936	56.8	68.2	11.4	Complied
5725	84.4	122.2	37.8	Complied
5850	77.3	122.2	44.9	Complied
5942.308	57.2	68.2	11.0	Complied

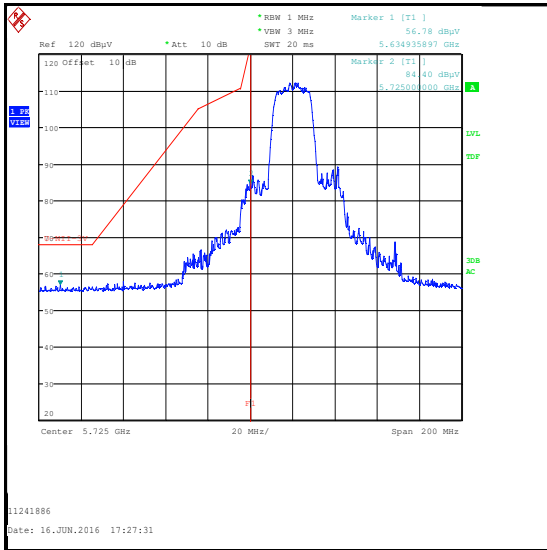

Lower Band Edge Measurement

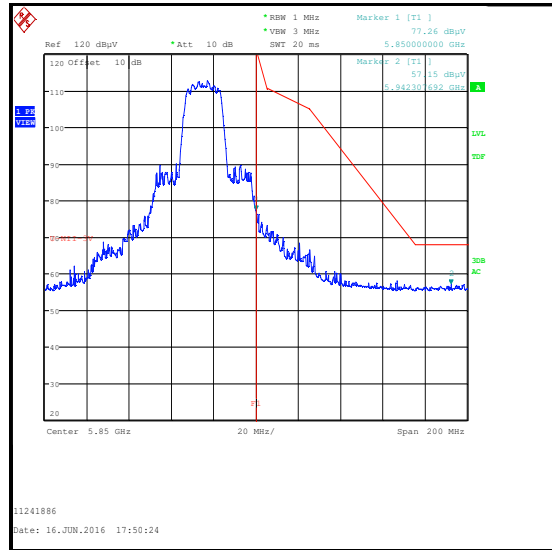

Upper Band Edge Measurement

Transmitter Band Edge Radiated Emissions (5.725-5.85 GHz operation) (continued)

Results: 802.11n / 40 MHz / BPSK / MCS0 / MIMO / Peak

Frequency (MHz)	Level (dBm)	Limit (dBm/MHz)	Margin (dB)	Result
5648.397	-37.3	-27.0	10.3	Complied
5725	-18.9	27.0	45.9	Complied
5850	-28.0	27.0	55.0	Complied
5935.256	-37.7	-27.0	10.7	Complied

Frequency (MHz)	Level (dBμV/m)	Limit (dBμV/m)	Margin (dB)	Result
5648.397	57.9	68.2	10.3	Complied
5725	76.3	122.2	45.9	Complied
5850	67.2	122.2	55.0	Complied
5935.256	57.5	68.2	10.7	Complied

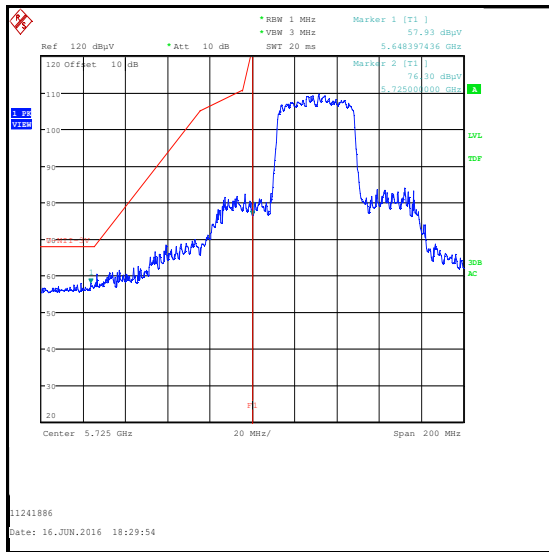

Lower Band Edge Measurement

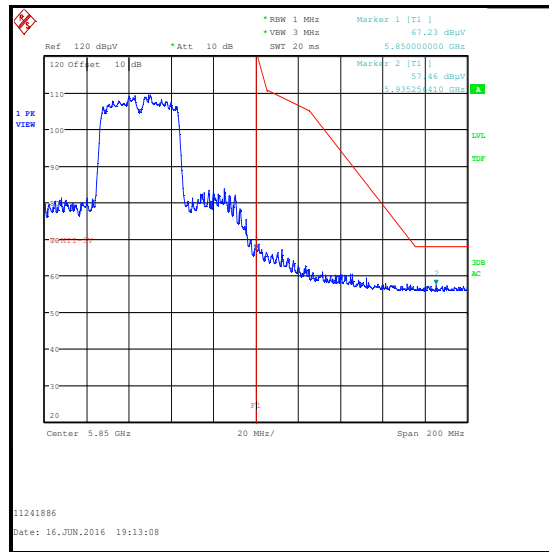

Upper Band Edge Measurement

Transmitter Band Edge Radiated Emissions (5.725-5.85 GHz operation) (continued)

Results: 802.11ac / 80 MHz / BPSK / MCS0x1 / MIMO / Peak

Frequency (MHz)	Level (dBm)	Limit (dBm/MHz)	Margin (dB)	Result
5646.795	-34.8	-27.0	7.8	Complied
5725	-30.9	27.0	57.9	Complied
5850	-26.1	27.0	53.1	Complied
5927.885	-35.4	-27.0	8.4	Complied

Frequency (MHz)	Level (dBμV/m)	Limit (dBμV/m)	Margin (dB)	Result
5646.795	60.4	68.2	7.8	Complied
5725	64.3	122.2	57.9	Complied
5850	69.1	122.2	53.1	Complied
5927.885	59.8	68.2	8.4	Complied

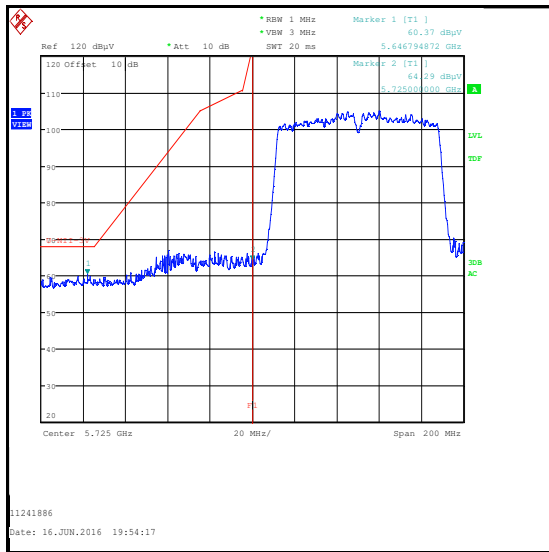

Lower Band Edge Measurement

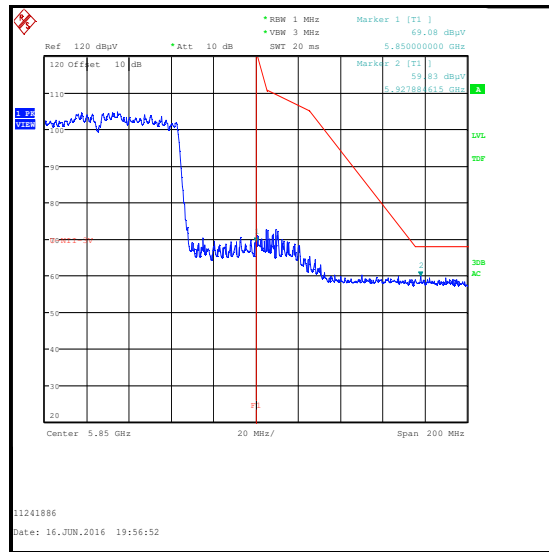

Upper Band Edge Measurement

Test Equipment Used:

Asset No.	Instrument	Manufacturer	Type No.	Serial No.	Date Calibration Due	Cal. Interval (Months)
M2003	Thermohyrometer	Testo	608-H1	45046641	22 Apr 2017	12
K0017	3m RSE Chamber	Rainford EMC	N/A	N/A	17 May 2017	12
M1995	Test Receiver	Rohde & Schwarz	ESU40	100428	21 Mar 2017	12
A2893	Pre-Amplifier	Schwarzbeck	BBV 9721	9721-021	07 Apr 2017	12
A2889	Antenna	Schwarzbeck	BBHA 9120 B	BBHA 9120 B	07 Apr 2017	12
A2916	Attenuator	AtlanTecRF	AN18W5-10	832827#1	19 May 2017	12

6. Measurement Uncertainty

No measurement or test can ever be perfect and the imperfections give rise to error of measurement in the results. Consequently the result of a measurement is only an approximation to the value of the measurand (the specific quantity subject to measurement) and is only complete when accompanied by a statement of the uncertainty of the approximation.

The expression of uncertainty of a measurement result allows realistic comparison of results with reference values and limits given in specifications and standards.

The uncertainty of the result may need to be taken into account when interpreting the measurement results.

The reported expanded uncertainties below are based on a standard uncertainty multiplied by an appropriate coverage factor such that a confidence level of approximately 95% is maintained. For the purposes of this document "approximately" is interpreted as meaning "effectively" or "for most practical purposes".

Measurement Type	Range	Confidence Level (%)	Calculated Uncertainty
Maximum Conducted Output Power	5.15 GHz to 5.850 GHz	95%	±1.13 dB
Maximum Power Spectral Density	5.15 GHz to 5.850 GHz	95%	±1.13 dB
Minimum 6 dB Emission Bandwidth	5.15 GHz to 5.850 GHz	95%	±4.59 %
26 dB Emission Bandwidth	5.15 GHz to 5.850 GHz	95%	±4.59 %
Radiated Spurious Emissions	30 MHz to 1 GHz	95%	±5.65 dB
Radiated Spurious Emissions	1 GHz to 40 GHz	95%	±2.94 dB

The methods used to calculate the above uncertainties are in line with those recommended within the various measurement specifications. Where measurement specifications do not include guidelines for the evaluation of measurement uncertainty the published guidance of the appropriate accreditation body is followed.

7. Report Revision History

Version Number	Revision Details		
	Page No(s)	Clause	Details
1.0	-	-	Initial Version
2.0	-	-	Section 5.2.7 updated
3.0	-	-	Updates requested by TCB
4.0	-	-	Note Added to section 5.2.4

--- END OF REPORT ---