

**Transmitter Minimum 6 dB Bandwidth (5.725-5.85 GHz band) (continued)**

**Results: 802.11n / 40 MHz / MIMO / BPSK / MCS0 / Port 1**

Channel	6 dB Bandwidth (kHz)	Limit (kHz)	Margin (kHz)	Result
Bottom	36208	≥500	35708	Complied
Top	35948	≥500	35448	Complied

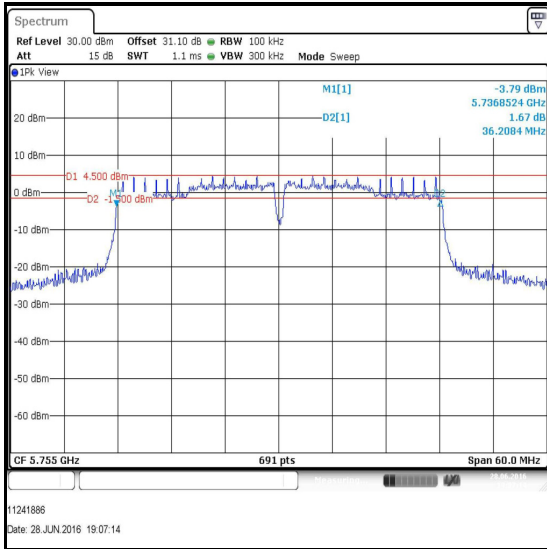

**Bottom Channel**

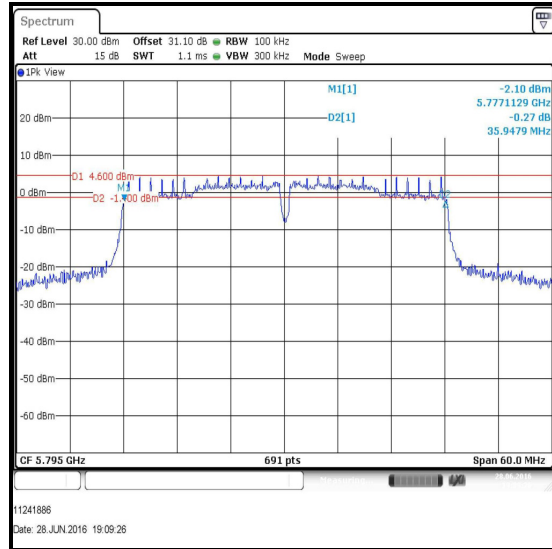

**Top Channel**

**Transmitter Minimum 6 dB Bandwidth (5.725-5.85 GHz band) (continued)**

**Results: 802.11n / 40 MHz / MIMO / BPSK / MCS0 / Port 2**

Channel	6 dB Bandwidth (kHz)	Limit (kHz)	Margin (kHz)	Result
Bottom	36469	≥500	35969	Complied
Top	36469	≥500	35969	Complied

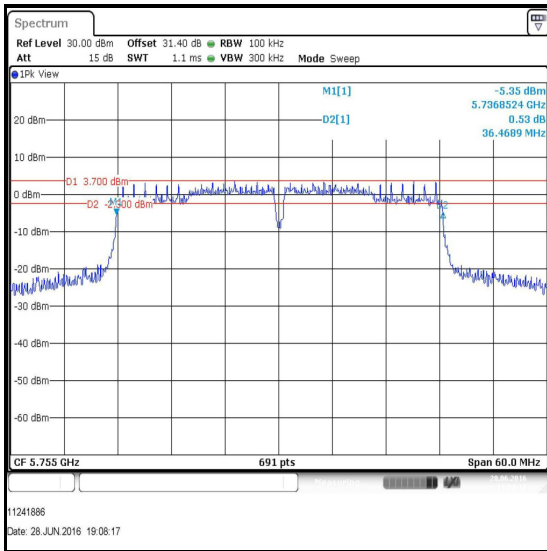

**Bottom Channel**

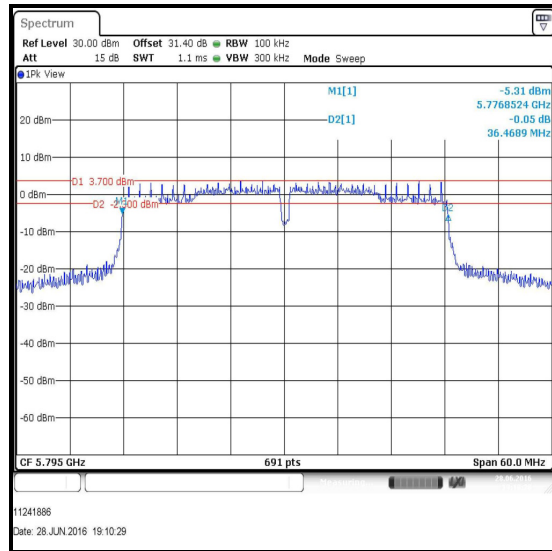

**Top Channel**

**Transmitter Minimum 6 dB Bandwidth (5.725-5.85 GHz band) (continued)**

**Results: 802.11ac / 80 MHz / MIMO / BPSK / MCS0x1 / Port 1**

Channel	6 dB Bandwidth (kHz)	Limit (kHz)	Margin (kHz)	Result
Single	76585	≥500	76085	Complied

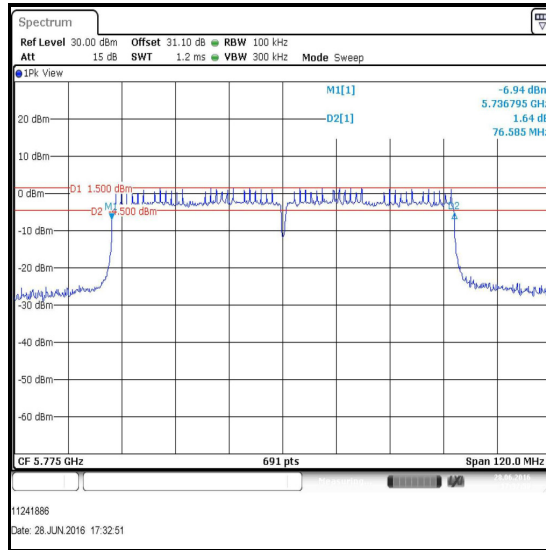

Single Channel

**Results: 802.11ac / 80 MHz / MIMO / BPSK / MCS0x1 / Port 2**

Channel	6 dB Bandwidth (kHz)	Limit (kHz)	Margin (kHz)	Result
Single	76585	≥500	76085	Complied

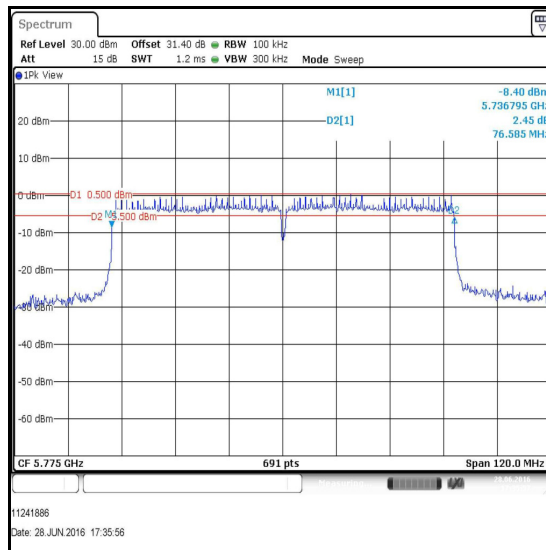

Single Channel

**Transmitter Minimum 6 dB Bandwidth (continued)****Test Equipment Used:**

<b>Asset No.</b>	<b>Instrument</b>	<b>Manufacturer</b>	<b>Type No.</b>	<b>Serial No.</b>	<b>Date Calibration Due</b>	<b>Cal. Interval (Months)</b>
M1659	Thermohygrometer	JM Handelpunkt	30.5015.13	None stated	02 Apr 2017	12
M1835	Signal Analyser	Rohde & Schwarz	FSV30	103050	27 Feb 2017	12
M1867	Attenuator	Huber + Suhner AG	6820.17.B	07101	Calibrated before use	-
A2847	Attenuator	Radiall	R411.820.121	24671450	Calibrated before use	-
A2345	Attenuator	Macom	2082-6043-20	None stated	Calibrated before use	-
A2952	RF Switch	Pickering Interfaces	64-102-002 & 40-881-001	XZ361012 & X361507	Calibrated before use	-
S0538	DC Power Supply	TTi	PL154	250135	Calibrated before use	-
M1818	Multimeter	Fluke	79III	71811580	27 Apr 2017	12
M1252	Signal Generator	Hewlett Packard	83640A	3119A00489	26 Oct 2017	24

**5.2.3. Transmitter Duty Cycle****Test Summary:**

<b>Test Engineer:</b>	Georgios Vrezas	<b>Test Date:</b>	28 June 2016
<b>Test Sample IMEI:</b>	358640070098109		

<b>FCC Reference:</b>	Part 15.35(c)
<b>Test Method Used:</b>	KDB 789033 D02 Section II.B.2.b)

**Environmental Conditions:**

<b>Temperature (°C):</b>	23
<b>Relative Humidity (%):</b>	39

**Note(s):**

- In order to assist with the determination of the average level of fundamental and spurious emissions field strength, measurements were made of duty cycle to determine the transmission duration and the silent period time of the transmitter. The transmitter duty cycle was measured using a spectrum analyser in the time domain and calculated by using the following calculation:

$$10 \log 1 / (\text{On Time} / [\text{Period or } 100\text{ms whichever is the lesser}]).$$

$$802.11n \text{ HT40} / \text{SISO} / \text{MCS0} \text{ duty cycle: } 10 \log (1 / (941.730/965.840)) = 0.1$$

$$802.11ac \text{ VHT80} / \text{SISO} / \text{MCS0} \text{ duty cycle: } 10 \log (1 / (458.868/481.721)) = 0.2$$

$$802.11n \text{ HT40} / \text{MIMO} / \text{MCS0} / \text{Port 1} \text{ duty cycle: } 10 \log (1 / (940.520/965.840)) = 0.1$$

$$802.11n \text{ HT40} / \text{MIMO} / \text{MCS0} / \text{Port 2} \text{ duty cycle: } 10 \log (1 / (941.730/965.840)) = 0.1$$

$$802.11ac \text{ VHT80} / \text{MIMO} / \text{MCS0x1} / \text{Port 1} \text{ duty cycle: } 10 \log (1 / (458.266/481.721)) = 0.2$$

$$802.11ac \text{ VHT80} / \text{MIMO} / \text{MCS0x1} / \text{Port 2} \text{ duty cycle: } 10 \log (1 / (458.265/481.720)) = 0.2$$

- Plots below are for data rates with a duty cycle less than 98%. Results for all other modes are archived on the Company server and available for inspection if required.
- The signal analyser was connected to the RF port on the EUT using an RF switch, suitable attenuation and RF cables. An RF level offset was entered on the signal analyser to compensate for the loss of the switch, attenuators and RF cables.

**Transmitter Duty Cycle (continued)**

**Test setup:**

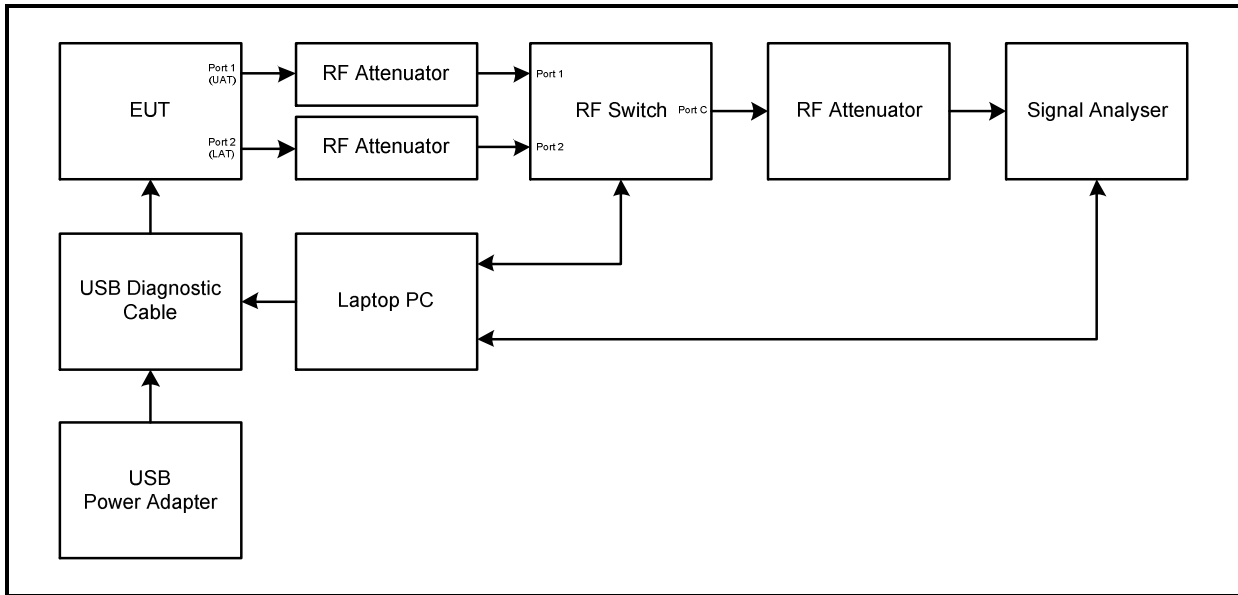

**Transmitter Duty Cycle (continued)**

**Results: 802.11n / 40 MHz / SISO / MCS0**

Pulse Duration (µs)	Period (µs)	Duty Cycle (dB)
941.730	965.840	0.1

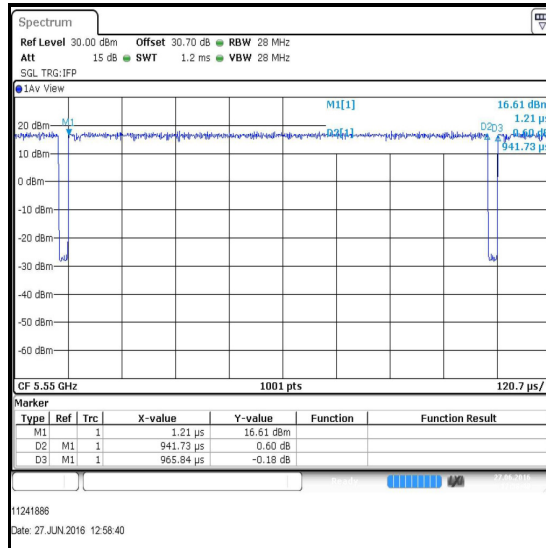

**Results: 802.11ac / 80 MHz / SISO / MCS0**

Pulse Duration (µs)	Period (µs)	Duty Cycle (dB)
458.868	481.721	0.2

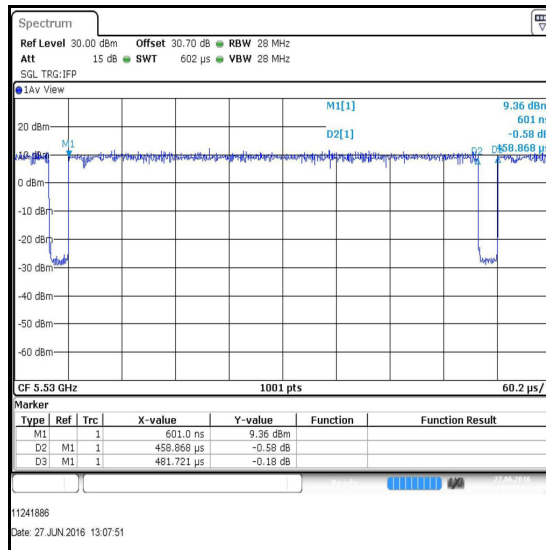

**Transmitter Duty Cycle (continued)**

**Results: 802.11n / 40 MHz / MIMO / MCS0 / Port 1**

Pulse Duration (µs)	Period (µs)	Duty Cycle (dB)
940.520	965.840	0.1

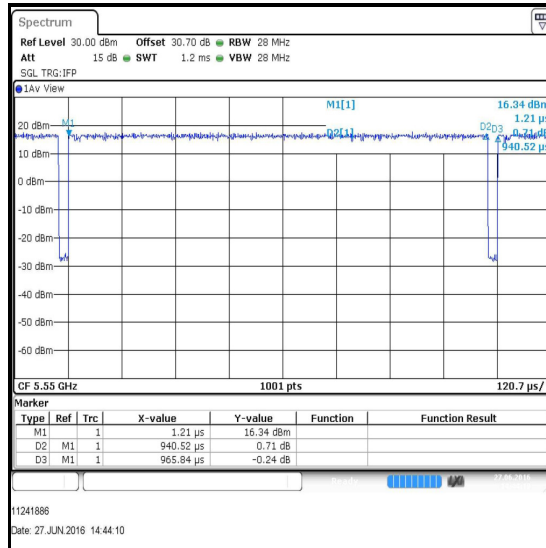

**Results: 802.11n / 40 MHz / MIMO / MCS0 / Port 2**

Pulse Duration (µs)	Period (µs)	Duty Cycle (dB)
941.730	965.840	0.1

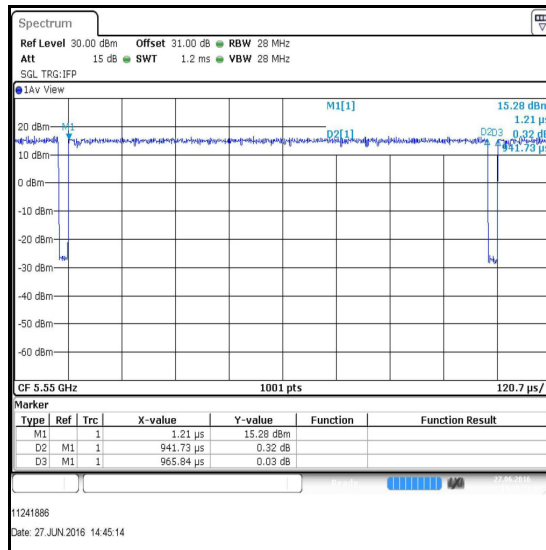

**Transmitter Duty Cycle (continued)**

**Results: 802.11ac / 80 MHz / MIMO / MCS0x1 / Port 1**

Pulse Duration (µs)	Period (µs)	Duty Cycle (dB)
458.266	481.721	0.2

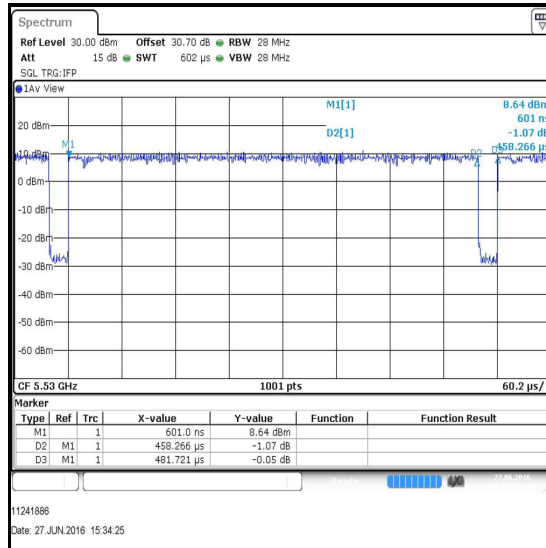

**Results: 802.11ac / 80 MHz / MIMO / MCS0x1 / Port 2**

Pulse Duration (µs)	Period (µs)	Duty Cycle (dB)
458.265	481.720	0.2

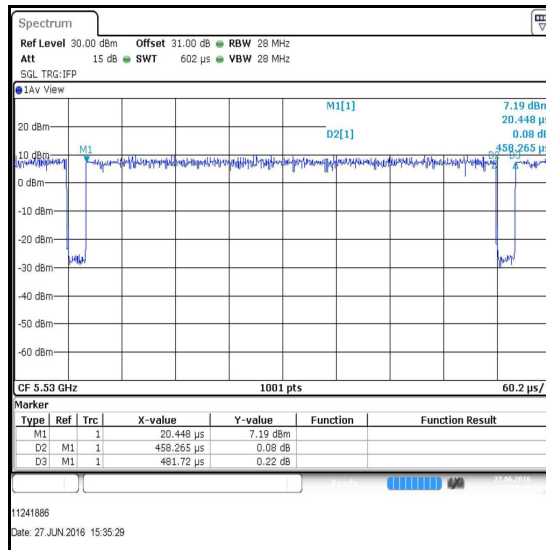

**Transmitter Duty Cycle (continued)****Test Equipment Used:**

<b>Asset No.</b>	<b>Instrument</b>	<b>Manufacturer</b>	<b>Type No.</b>	<b>Serial No.</b>	<b>Date Calibration Due</b>	<b>Cal. Interval (Months)</b>
M1659	Thermohygrometer	JM Handelspunkt	30.5015.13	None stated	02 Apr 2017	12
M1835	Signal Analyser	Rohde & Schwarz	FSV30	103050	27 Feb 2017	12
M1867	Attenuator	Huber + Suhner AG	6820.17.B	07101	Calibrated before use	-
A2847	Attenuator	Radiall	R411.820.121	24671450	Calibrated before use	-
A2345	Attenuator	Macom	2082-6043-20	None stated	Calibrated before use	-
A2952	RF Switch	Pickering Interfaces	64-102-002 & 40-881-001	XZ361012 & X361507	Calibrated before use	-
S0538	DC Power Supply	TTi	PL154	250135	Calibrated before use	-
M1818	Multimeter	Fluke	79III	71811580	27 Apr 2017	12
M1252	Signal Generator	Hewlett Packard	83640A	3119A00489	26 Oct 2017	24

**5.2.4. Transmitter Maximum Conducted Output Power****Test Summary:**

<b>Test Engineer:</b>	Georgios Vrezas	<b>Test Dates:</b>	28 June 2016 & 21 July 2016
<b>Test Sample IMEI:</b>	358640070098109		

<b>FCC Reference:</b>	Part 15.407(a)(1)(iv)
<b>Test Method Used:</b>	KDB 789033 D02 Section II.E.2.b) and II.E.2.d)

**Environmental Conditions:**

<b>Temperature (°C):</b>	24 to 25
<b>Relative Humidity (%):</b>	45 to 46

**Note(s):**

- For conducted power tests where the duty cycle is >98%, the measurements were performed using a signal analyser in accordance with FCC KDB 789033 II.E.2.b) Method SA-1. Where the duty cycle is <98%, the measurements were performed in accordance with FCC KDB 789033 II.E.2.d) Method SA-2.
- The customer declared the following data rates to be used for all measurements as:
  - 802.11a – BPSK / 6 Mbps / Port 1
  - 802.11n HT20 SISO – BPSK / 6.5 Mbps / MCS0 / Port 1
  - 802.11n HT40 SISO – BPSK / 13.5 Mbps / MCS0 / Port 1
  - 802.11ac VHT80 SISO – BPSK / 29.3 Mbps / MCS0 / Port 1
  - 802.11n HT20 MIMO – BPSK / 6.5 Mbps / MCS0
  - 802.11n HT40 MIMO – BPSK / 13.5 Mbps / MCS0
  - 802.11ac VHT80 MIMO – BPSK / 29.3 Mbps / MCS0x1

Measurements were then performed in these modes on all relevant channels in all operating bands.

- For data rates where the EUT was transmitting at <98% duty cycle, the calculated duty cycle in section 5.2.3 was added to the measured power in order to compute the average power during the actual transmission time.
- Power was measured on both ports and then combined using the measure-and-sum technique stated in FCC KDB 662911 D01 Section E)1).
- For SISO modes, the antenna gain is < 6 dBi.
- For MIMO modes presented in this section of the test report, the data stream is correlated as it is single stream with CDD on. The directional antenna gain has been calculated in accordance with ANSI C63.10 Section 14.4.3.2.4 b). The EUT antenna has a gain of -4.7 dBi for port 1 and -6.0 dBi for port 2, in the frequency range 5.15 GHz to 5.25 GHz:

$$\begin{aligned} \text{Directional Gain} &= 10 \log \left[ \frac{\sum_{j=1}^{N_{SS}} (\sum_{k=1}^{N_{ANT}} g_{j,k})^2}{N_{ANT}} \right] = 10 \log \left[ \frac{\sum_{j=1}^1 (\sum_{k=1}^2 g_{j,k})^2}{2} \right] \\ &= 10 \log \left[ \frac{(g_{1,1} + g_{1,2})^2}{2} \right] = 10 \log \left[ \frac{\left(10^{\frac{G_1}{20}} + 10^{\frac{G_2}{20}}\right)^2}{2} \right] = 10 \log \left[ \frac{\left(10^{\frac{-4.7}{20}} + 10^{\frac{-6.0}{20}}\right)^2}{2} \right] = -2.3 \text{ dBi} \end{aligned}$$

**Transmitter Maximum Conducted Output Power (5.15-5.25 GHz band) (continued)**

**Note(s):**

7. The signal analyser was connected to the RF port on the EUT using an RF switch, suitable attenuation and RF cables. An RF level offset was entered on the signal analyser to compensate for the loss of the switch, attenuators and RF cables.
8. The Part 15.407(a)(1)(iv) limit shall not exceed 250 mW (24.0 dBm).
9. Testing was performed with the EUT transmitting with power levels equal to or greater than those stated in the respective SAR test report. WLAN modes which provided higher output powers than those given within the SAR report, are the result of the device being configured with higher power settings for testing purposes.

**Test setup:**

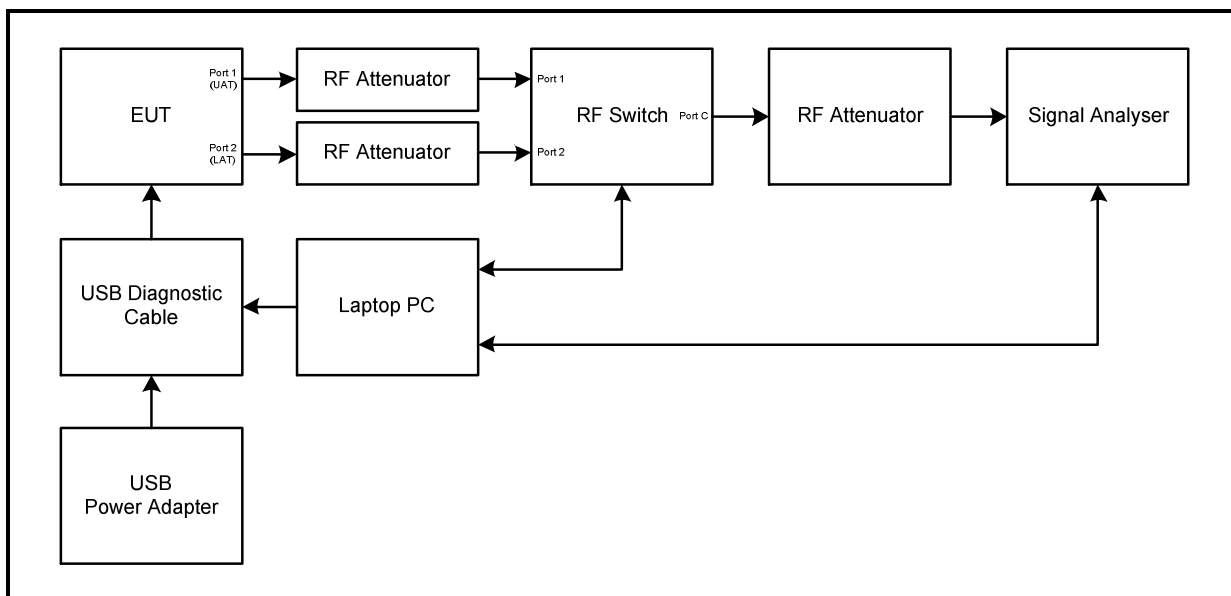

**Transmitter Maximum Conducted Output Power (5.15-5.25 GHz band) (continued)**

**Results: 802.11a / 20 MHz / BPSK / 6 Mbps**

Channel	Frequency (MHz)	Conducted Power (dBm)	Limit (dBm)	Margin (dB)	Result
Bottom	5180	17.1	24.0	6.9	Complied
Middle	5200	19.3	24.0	4.7	Complied
Top	5240	19.1	24.0	4.9	Complied

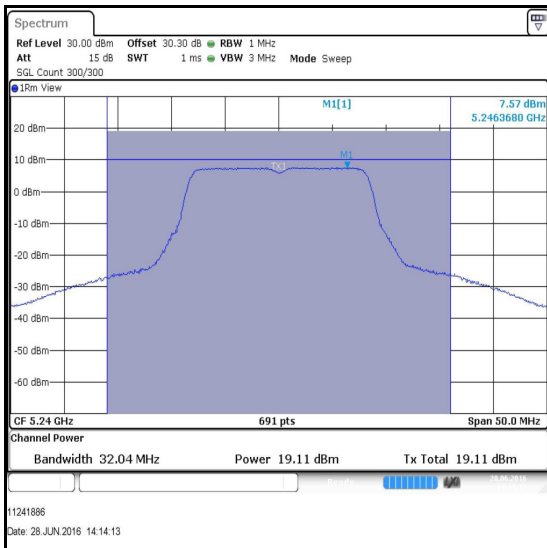
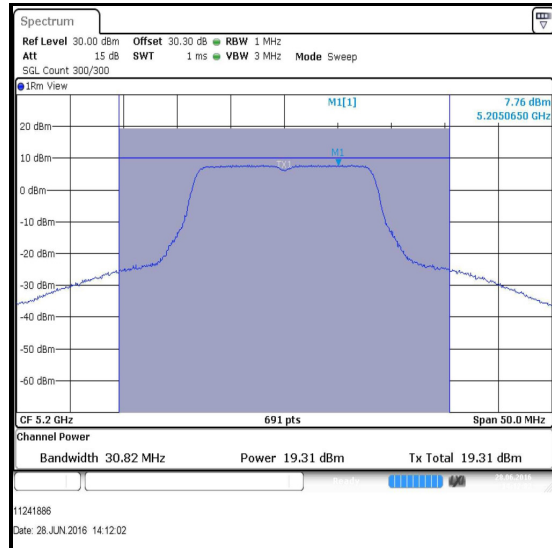
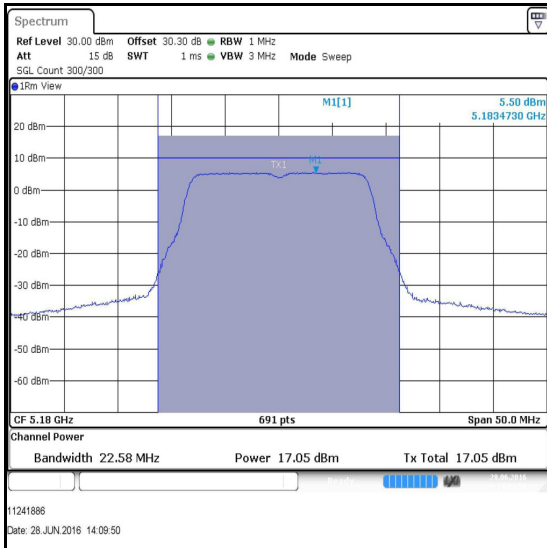

**Transmitter Maximum Conducted Output Power (5.15-5.25 GHz band) (continued)**

**Results: 802.11n / 20 MHz / BPSK / MCS0 / SISO**

Channel	Frequency (MHz)	Conducted Power (dBm)	Limit (dBm)	Margin (dB)	Result
Bottom	5180	17.1	24.0	6.9	Complied
Middle	5200	19.3	24.0	4.7	Complied
Top	5240	19.0	24.0	5.0	Complied

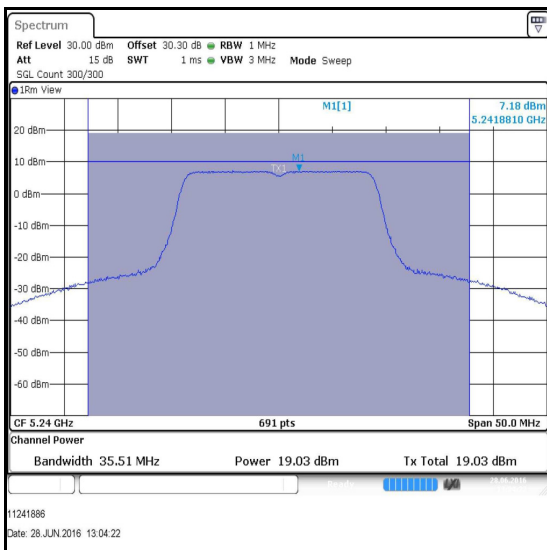
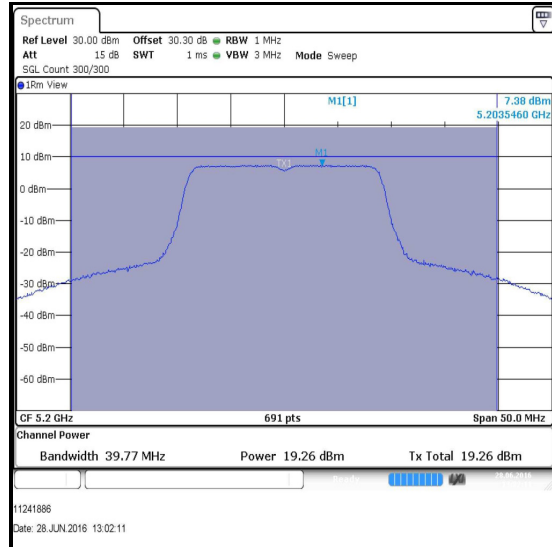
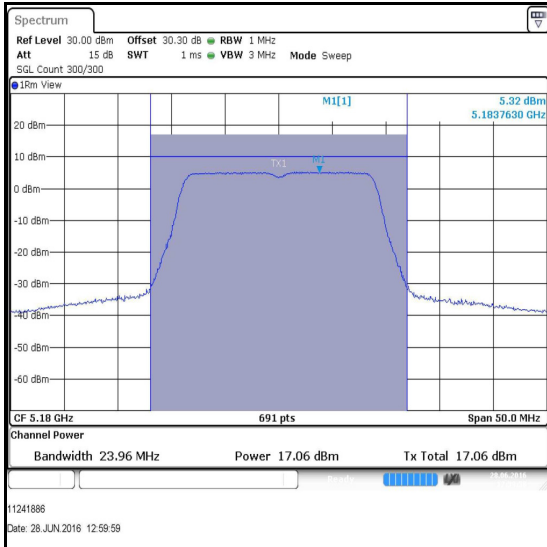

**Transmitter Maximum Conducted Output Power (5.15-5.25 GHz band) (continued)**

**Results: 802.11n / 40 MHz / BPSK / MCS0 / SISO**

Channel	Frequency (MHz)	Conducted Power (dBm)	Duty cycle correction factor (dB)	Corrected Conducted Power (dBm)	Limit (dBm)	Margin (dB)	Result
Bottom	5190	16.3	0.1	16.4	24.0	7.6	Complied
Top	5230	18.5	0.1	18.6	24.0	5.4	Complied

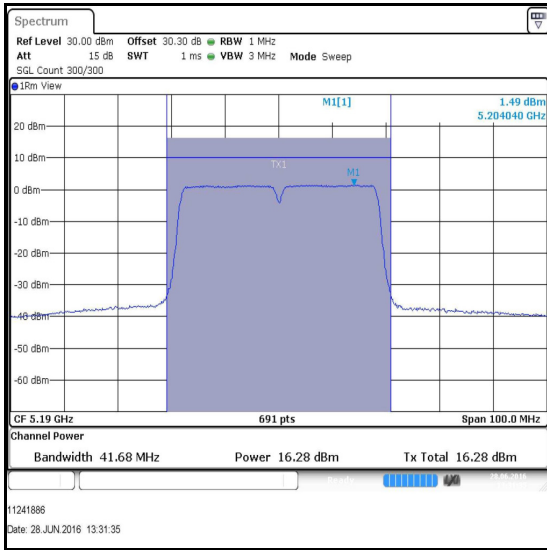

**Bottom Channel**

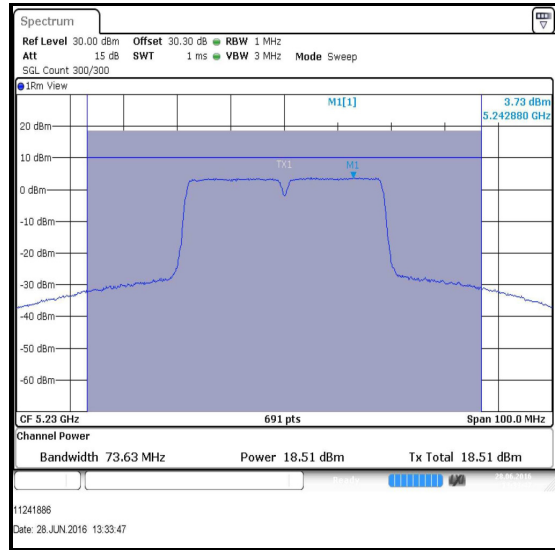

**Top Channel**

**Transmitter Maximum Conducted Output Power (5.15-5.25 GHz band) (continued)**

**Results: 802.11ac / 80 MHz / BPSK / MCS0 / SISO**

Channel	Frequency (MHz)	Conducted Power (dBm)	Duty cycle correction factor (dB)	Corrected Conducted Power (dBm)	Limit (dBm)	Margin (dB)	Result
Single	5210	14.8	0.2	15.0	24.0	9.0	Complied

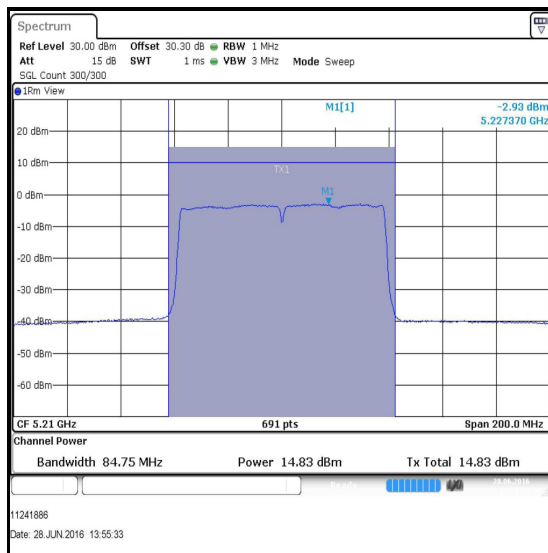

**Single Channel**

**Transmitter Maximum Conducted Output Power (5.15-5.25 GHz band) (continued)**

**Results: 802.11n / 20 MHz / BPSK / MCS0 / MIMO**

Channel	Frequency (MHz)	Conducted Power Port 1 (dBm)	Conducted Power Port 2 (dBm)	Combined Conducted Power (dBm)	Limit (dBm)	Margin (dB)	Result
Bottom	5180	16.5	15.2	18.9	24.0	5.1	Complied
Middle	5200	16.7	15.2	19.0	24.0	5.0	Complied
Top	5240	16.8	15.6	19.3	24.0	4.7	Complied

**Results: 802.11n / 20 MHz / BPSK / MCS0 / MIMO / Port 1**

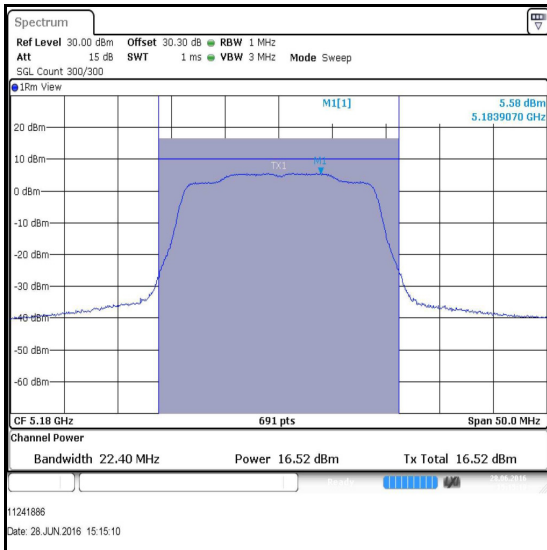

**Bottom Channel**

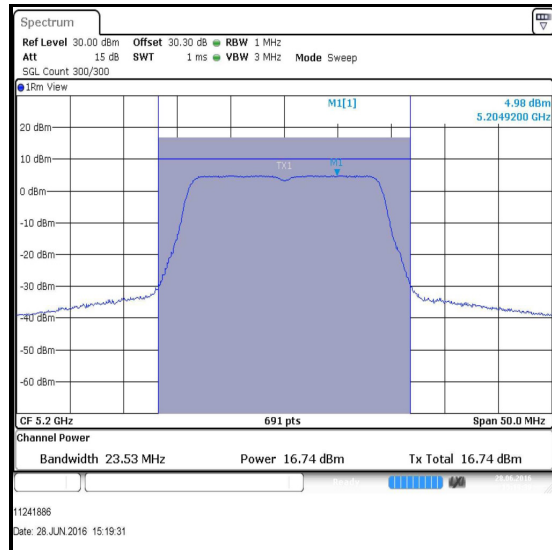

**Middle Channel**

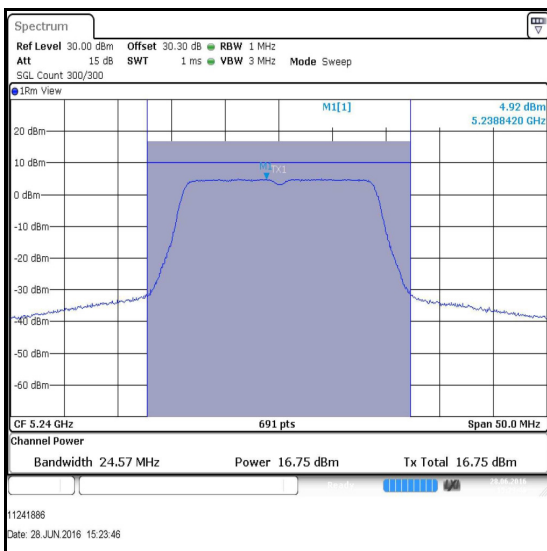

**Top Channel**

**Transmitter Maximum Conducted Output Power (5.15-5.25 GHz band) (continued)**

**Results: 802.11n / 20 MHz / BPSK / MCS0 / MIMO / Port 2**



**Bottom Channel**

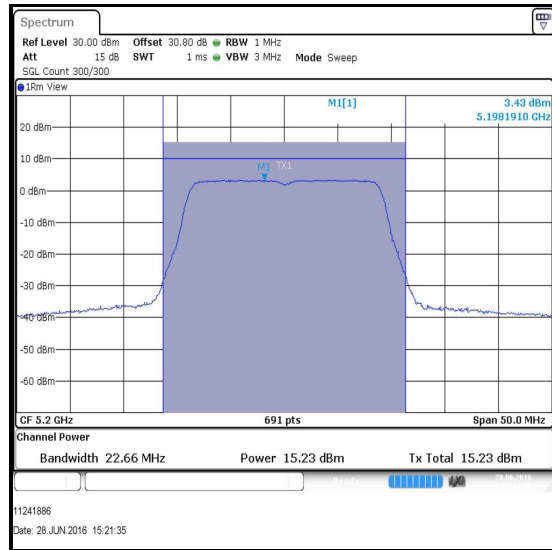

**Middle Channel**

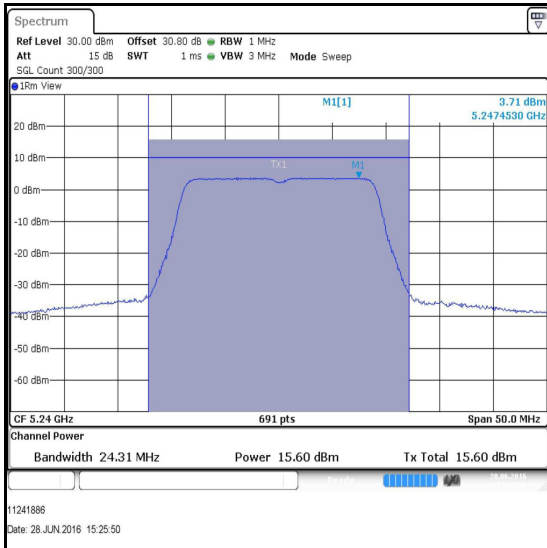

**Top Channel**

**Transmitter Maximum Conducted Output Power (5.15-5.25 GHz band) (continued)****Results: 802.11n / 40 MHz / BPSK / MCS0 / MIMO**

Channel	Frequency (MHz)	Port 1			Port 2		
		Conducted Power (dBm)	Duty Cycle Correction (dB)	Corrected Conducted Power (dBm)	Conducted Power (dBm)	Duty Cycle Correction (dB)	Corrected Conducted Power (dBm)
Bottom	5190	14.0	0.1	14.1	12.2	0.1	12.3
Top	5230	18.9	0.1	19.0	17.4	0.1	17.5

Channel	Corrected Conducted Power Port 1 (dBm)	Corrected Conducted Power Port 2 (dBm)	Combined Conducted Power (dBm)	Limit (dBm)	Margin (dB)	Result
Bottom	14.1	12.3	16.3	24.0	7.7	Complied
Top	19.0	17.5	21.3	24.0	2.7	Complied

**Transmitter Maximum Conducted Output Power (5.15-5.25 GHz band) (continued)**

**Results: 802.11n / 40 MHz / BPSK / MCS0 / MIMO / Port 1**

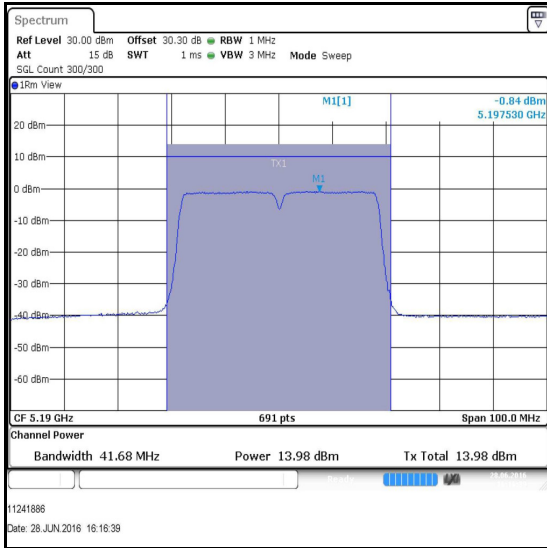

Bottom Channel

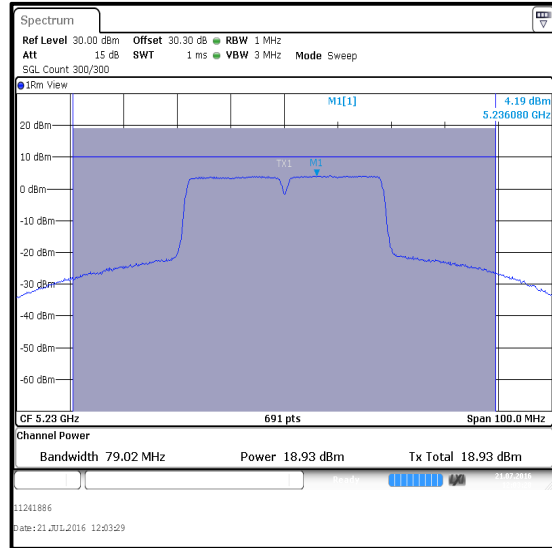

Top Channel

**Results: 802.11n / 40 MHz / BPSK / MCS0 / MIMO / Port 2**

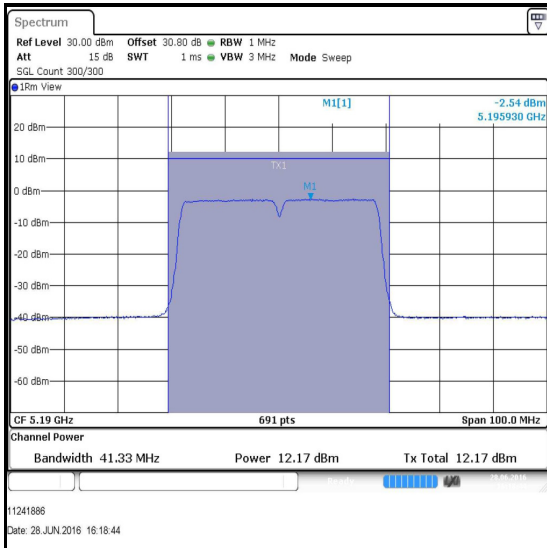

Bottom Channel

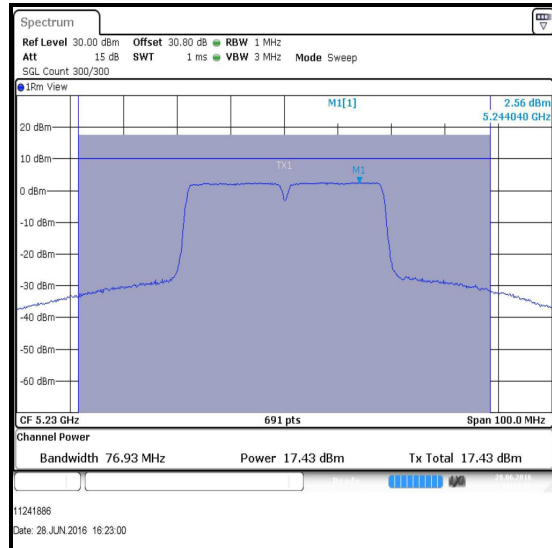

Top Channel

**Transmitter Maximum Conducted Output Power (5.15-5.25 GHz band) (continued)**

**Results: 802.11ac / 80 MHz / BPSK / MCS0x1 / MIMO**

Channel	Frequency (MHz)	Port 1			Port 2		
		Conducted Power (dBm)	Duty Cycle Correction (dB)	Corrected Conducted Power (dBm)	Conducted Power (dBm)	Duty Cycle Correction (dB)	Corrected Conducted Power (dBm)
Single	5210	14.6	0.2	14.8	12.9	0.2	13.1

Channel	Corrected Conducted Power Port 1 (dBm)	Corrected Conducted Power Port 2 (dBm)	Combined Conducted Power (dBm)	Limit (dBm)	Margin (dB)	Result
Single	14.8	13.1	17.0	24.0	7.0	Complied