



TEST REPORT

Test Report No. : UL-RPT-RP11241886JD07E V4.0

Manufacturer : Apple Inc.
Model No. : A1779
FCC ID : BCG-E3086A
Technology : WLAN
Test Standard(s) : FCC Parts 15.207, 15.209(a) & 15.247

1. This test report shall not be reproduced in full or partial, without the written approval of UL VS LTD.
2. The results in this report apply only to the sample(s) tested.
3. The sample tested is in compliance with the above standard(s).
4. The test results in this report are traceable to the national or international standards.
5. Version 4.0 supersedes all previous versions.

Date of Issue: 03 August 2016

Checked by:

Steven White
Service Lead, Radio Laboratory

Company Signatory:

Sarah Williams
Senior Engineer, Radio Laboratory
UL VS LTD



This laboratory is accredited by UKAS.
The tests reported herein have been
performed in accordance with its terms
of accreditation.

UL VS LTD

Pavilion A, Ashwood Park, Ashwood Way, Basingstoke, Hampshire, RG23 8BG, UK
Telephone: +44 (0)1256 312000
Facsimile: +44 (0)1256 312001

This page has been left intentionally blank.

Table of Contents

1. Customer Information.....	4
2. Summary of Testing.....	5
2.1. General Information	5
2.2. Summary of Test Results	5
2.3. Methods and Procedures	6
2.4. Deviations from the Test Specification	6
3. Equipment Under Test (EUT)	7
3.1. Identification of Equipment Under Test (EUT)	7
3.2. Description of EUT	7
3.3. Modifications Incorporated in the EUT	7
3.4. Additional Information Related to Testing	8
3.5. Support Equipment	9
4. Operation and Monitoring of the EUT during Testing	10
4.1. Operating Modes	10
4.2. Configuration and Peripherals	10
5. Measurements, Examinations and Derived Results.....	11
5.1. General Comments	11
5.2. Test Results	12
5.2.1. Transmitter Minimum 6 dB Bandwidth	12
5.2.2. Transmitter Power Spectral Density	23
5.2.3. Transmitter Maximum (Average) Output Power	35
5.2.4. Transmitter Radiated Emissions	48
5.2.5. Transmitter Band Edge Radiated Emissions	54
6. Measurement Uncertainty	75
7. Report Revision History	76
8. Appendix 1	77
Transmitter 99% Emission Bandwidth Reference Plots	77

1. Customer Information

Company Name:	Apple Inc.
Address:	1 Infinite Loop Cupertino, CA 95014 U.S.A.

2. Summary of Testing

2.1. General Information

Specification Reference:	47CFR15.247
Specification Title:	Code of Federal Regulations Volume 47 (Telecommunications): Part 15 Subpart C (Intentional Radiators) - Section 15.247
Site Registration:	209735
Location of Testing:	UL VS LTD, Unit 3 Horizon, Wade Road, Kingsland Business Park, Basingstoke, Hampshire, RG24 8AH, United Kingdom
Test Dates:	14 June 2016 to 30 July 2016

2.2. Summary of Test Results

FCC Reference (47CFR)	Measurement	Result
Part 15.247(a)(2)	Transmitter Minimum 6 dB Bandwidth	Complied
Part 15.35(c)	Transmitter Duty Cycle	Note 1
Part 15.247(e)	Transmitter Power Spectral Density	Complied
Part 15.247(b)(3)	Transmitter Maximum (Average) Output Power	Complied
Part 15.247(d) & 15.209(a)	Transmitter Radiated Emissions	Complied
Part 15.247(d) & 15.209(a)	Transmitter Band Edge Radiated Emissions	Complied

Note(s):

- For the data rates declared as worst cases and tested in this test report, duty cycle was measured to be greater than 98%. Plots for these measurements are archived on the company server and available for inspection upon request.
- There are two vendors of the WiFi/Bluetooth radio modules, Vendor 1 and Vendor 2.
The WiFi/Bluetooth radio modules have the same mechanical outline (e.g. the same packaging dimension and pin layout), use the same on-board antenna matching circuit, have an identical antenna structure and are built and tested to conform to the same specification and to operate within the same tolerances.
Baseline testing was performed on the two vendors to determine the worst case.

2.3. Methods and Procedures

Reference:	ANSI C63.10-2013
Title:	American National Standard of Procedures for Compliance Testing of Unlicensed Wireless Devices
Reference:	KDB 558074 D01 DTS Meas Guidance v03r05 April 8, 2016
Title:	Guidance for Performing Compliance Measurements on Digital Transmission Systems (DTS) Operating Under §15.247
Reference:	KDB 662911 D01 Multiple Transmitter Output v02r01 October 31, 2013
Title:	Emissions Testing of Transmitters with Multiple Outputs in the Same Band

2.4. Deviations from the Test Specification

For the measurements contained within this test report, there were no deviations from, additions to, or exclusions from the test specification identified above.

3. Equipment Under Test (EUT)

3.1. Identification of Equipment Under Test (EUT)

Brand Name:	Apple
Model Name or Number:	A1779
Test Sample Serial Number:	C7CRR02BHCPX (<i>Conducted sample</i>)
Test Sample IMEI:	358640070036851
Hardware Version:	REV1.0
Firmware Version:	9.44.11.27
Test Utility Software:	wl 1.359 RC65.0
FCC ID:	BCG-E3086A

Brand Name:	Apple
Model Name or Number:	A1779
Test Sample Serial Number:	C7CRR00BHCPX (<i>Radiated sample #1</i>)
Test Sample IMEI:	358640070063996
Hardware Version:	REV1.0
Firmware Version:	9.44.11.27
Test Utility Software:	wl 1.359 RC65.0
FCC ID:	BCG-E3086A

Brand Name:	Apple
Model Name or Number:	A1779
Test Sample Serial Number:	C7CRR00GHCPX (<i>Radiated sample #2</i>)
Test Sample IMEI:	358640070066106
Hardware Version:	REV1.0
Firmware Version:	9.44.11.27
Test Utility Software:	wl 1.359 RC65.0
FCC ID:	BCG-E3086A

3.2. Description of EUT

The Equipment Under Test was a mobile phone with GSM/GPRS/EGPRS/UMTS/LTE/TD-SCDMA and CDMA technologies. It also supports IEEE 802.11a/b/g/n/ac, Bluetooth®, GPS and NFC. The rechargeable battery is not user accessible.

3.3. Modifications Incorporated in the EUT

No modifications were applied to the EUT during testing.

3.4. Additional Information Related to Testing

Technology Tested:	WLAN (IEEE 802.11b,g,n) / Digital Transmission System	
Type of Unit:	Transceiver	
Modulation Type:	DBPSK, DQPSK, BPSK, QPSK, 16QAM & 64QAM	
Data Rates:	802.11b (SISO)	1, 2, 5.5 & 11 Mbps
	802.11g (SISO)	6, 9, 12, 18, 24, 36, 48 & 54 Mbps
	802.11n HT20 (SISO)	MCS0 to MCS7
	802.11n HT20 (MIMO)	MCS0 to MCS15 (CDD MCS0 to MCS7)
Power Supply Requirement(s):	Nominal	3.8 VDC via 120 VAC 60 Hz adaptor
Maximum Conducted Output Power:	21.9 dBm	
Declared Antenna Gains:	Antenna 1	-1.8 dBi
	Antenna 2	-1.2 dBi
Channel Spacing:	20 MHz	
Transmit Frequency Range:	2412 MHz to 2472 MHz	
Transmit Channels Tested:	Channel Number	Channel Frequency (MHz)
	1	2412
	2	2417
	6	2437
	10	2457
	11	2462
	12	2467
	13	2472

3.5. Support Equipment

The following support equipment was used to exercise the EUT during testing:

Brand Name:	Lenovo
Description:	Laptop PC
Model Name or Number:	ThinkPad L440
Serial Number:	R9-019E92

Description:	Test Laptop
Brand Name:	Apple
Model Name or Number:	MacBook Pro
Serial Number:	C2QH700QDY20

Brand Name:	Not stated
Description:	USB Diagnostic Cable
Model Name or Number:	Not stated
Serial Number:	Not stated

Description:	Personal Hands-Free
Brand Name:	Apple
Model Name or Number:	Apple Ear Plugs
Serial Number:	Not stated

4. Operation and Monitoring of the EUT during Testing

4.1. Operating Modes

The EUT was tested in the following operating mode(s):

- Continuously transmitting with a modulated carrier at maximum power on the relevant channels as required using the supported data rates/modulation types.

4.2. Configuration and Peripherals

The EUT was tested in the following configuration(s):

- For radiated measurements: Controlled using a bespoke application on the laptop PC supplied by the customer. The application was used to enable a continuous transmission mode and to select the test channels, data rates and modulation schemes as required.
- For conducted measurements: Controlled using software *RePlay v.2.6.0.7* on a laptop PC. The application was used to enable a continuous transmission mode and to select the test channels, data rates and modulation schemes as required. The customer supplied documents with test instructions, titled *A1500J_Power_Tables_for_conducted_testing_v10* and *AA1500J_FCC_BE_Commands_v7*.
- The customer declared the following data rates to be used for all measurements as:
 - 802.11b – DBPSK / 1 Mbps / Port 1
 - 802.11g – BPSK / 6 Mbps / Port 1
 - 802.11n HT20 SISO – BPSK / 6.5 Mbps / MCS0 / Port 1
 - 802.11n HT20 MIMO – BPSK / 6.5 Mbps / MCS0
- The EUT has two separate antennas which correspond to two separate antenna ports. Port 1 and Port 2 correspond to antenna 1 (UAT) and antenna 2 (LAT) respectively.
- The EUT was placed in three orthogonal orientations X, Y and Z to determine the worst case orientation for radiated spurious emissions. The worst case orientation was Z.
- Transmitter spurious emissions were performed with the EUT transmitting with a data rate of 802.11n / MCS0 / MIMO. This was found to be the worst case modulation scheme with regards to emissions after preliminary investigations and, as this mode emits the highest output power level, it was deemed to be the worst case.
- Transmitter radiated spurious emissions tests were performed with the PHF connected to the EUT.
- The worst-case radiated emission among all accessories is determined by the manufacturer to be with the headset connected. The compliance lab performed final testing only with the headset.

5. Measurements, Examinations and Derived Results

5.1. General Comments

Measurement uncertainties are evaluated in accordance with current best practice. Our reported expanded uncertainties are based on standard uncertainties, which are multiplied by an appropriate coverage factor to provide a statistical confidence level of approximately 95%. Please refer to *Section 6. Measurement Uncertainty* for details.

In accordance with UKAS requirements all the measurement equipment is on a calibration schedule. All equipment was within the calibration period on the date of testing.

5.2. Test Results

5.2.1. Transmitter Minimum 6 dB Bandwidth

Test Summary:

Test Engineer:	Georgios Vrezas	Test Dates:	22 June 2016 to 04 July 2016
Test Sample Serial Number:	C7CRR02BHCPX		

FCC Reference:	Part 15.247(a)(2)
Test Method Used:	FCC KDB 558074 Section 8.1

Environmental Conditions:

Temperature (°C):	24 to 25
Relative Humidity (%):	36 to 45

Note(s):

- The customer declared the following data rates to be used for all measurements as:
 - 802.11b – DBPSK / 1 Mbps / Port 1
 - 802.11g – BPSK / 6 Mbps / Port 1
 - 802.11n HT20 SISO – BPSK / 6.5 Mbps / MCS0 (GI = 800 ns) / Port 1
 - 802.11n HT20 MIMO – BPSK / 6.5 Mbps / MCS0 (GI = 800 ns)
- Final measurements were performed using the above configurations on the relevant channels in accordance with KDB 558074 Section 8.1 Option 1 measurement procedure. The signal analyser resolution bandwidth was set to 100 kHz and video bandwidth 300 kHz. A peak detector was used, sweep time was set to auto and the trace mode was Max Hold. The span was set to 40 MHz. The DTS bandwidth was measured at 6 dB down from the peak of the signal.
- The signal analyser was connected to the RF port on the EUT using an RF switch, suitable attenuation and RF cables.

Test setup:

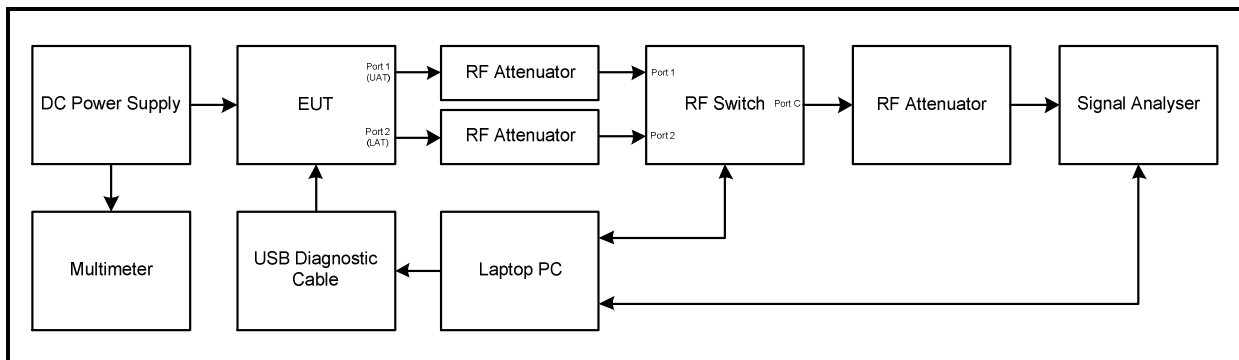

Transmitter Minimum 6 dB Bandwidth (continued)

Results: 802.11b / 20 MHz / DBPSK / 1 Mbps

Channel	6 dB Bandwidth (kHz)	Limit (kHz)	Margin (kHz)	Result
1	8640	≥500	8140	Complied
6	8162	≥500	7662	Complied
11	8119	≥500	7619	Complied
12	8596	≥500	8096	Complied
13	8596	≥500	8096	Complied

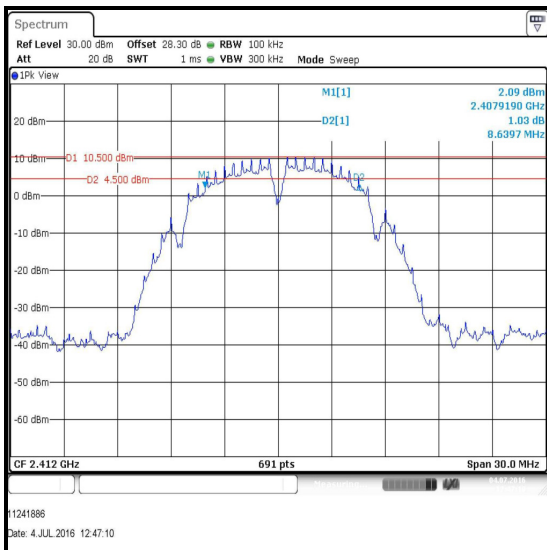

Channel 1

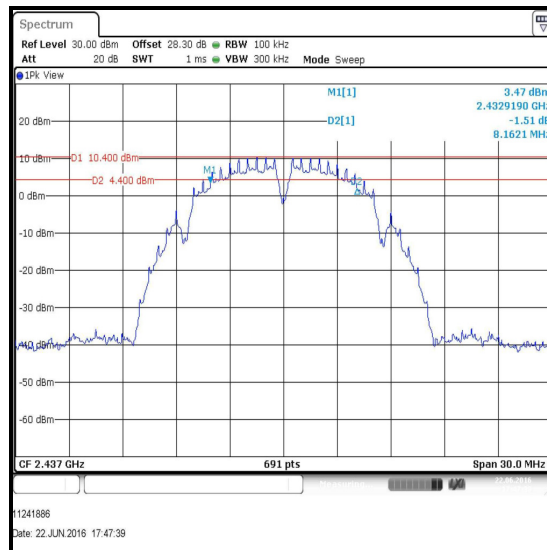

Channel 6

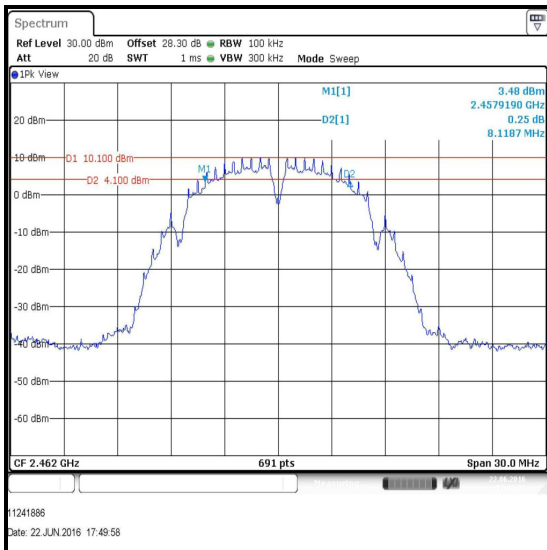

Channel 11

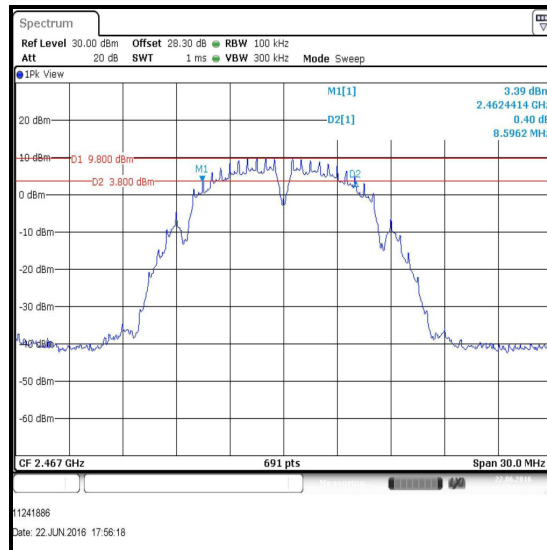

Channel 12

Transmitter Minimum 6 dB Bandwidth (continued)

Results: 802.11b / 20 MHz / DBPSK / 1 Mbps

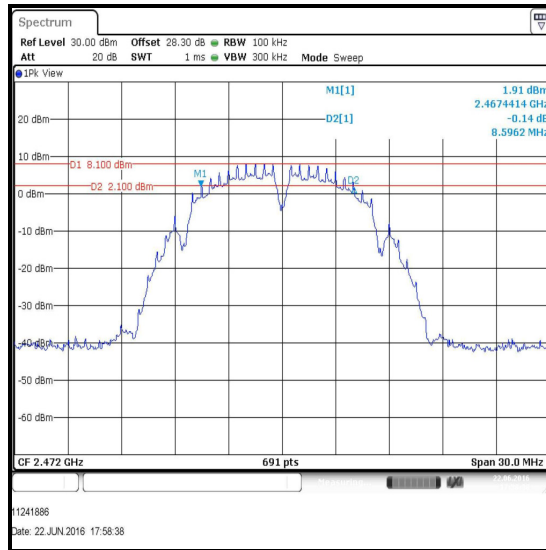

Channel 13

Transmitter Minimum 6 dB Bandwidth (continued)

Results: 802.11g / 20 MHz / BPSK / 6 Mbps

Channel	6 dB Bandwidth (kHz)	Limit (kHz)	Margin (kHz)	Result
1	15803	≥500	15303	Complied
6	16151	≥500	15651	Complied
11	16107	≥500	15607	Complied
12	15803	≥500	15303	Complied
13	15803	≥500	15303	Complied

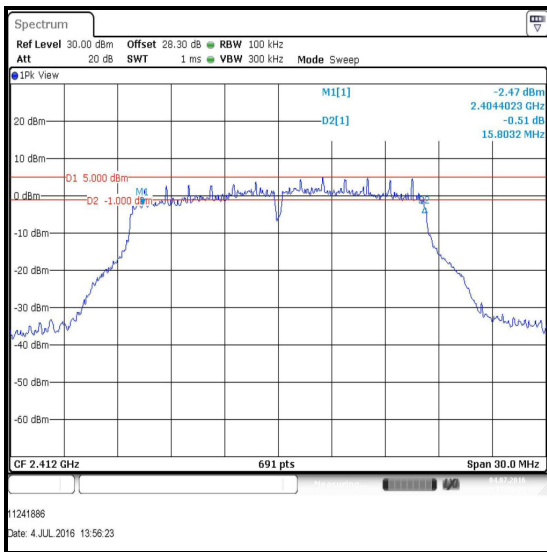

Channel 1

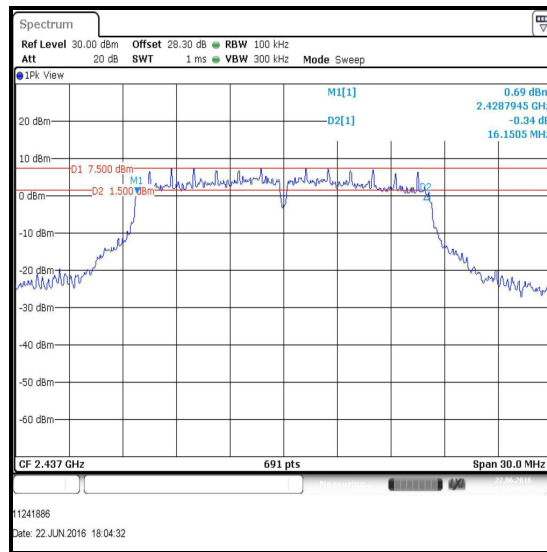

Channel 6

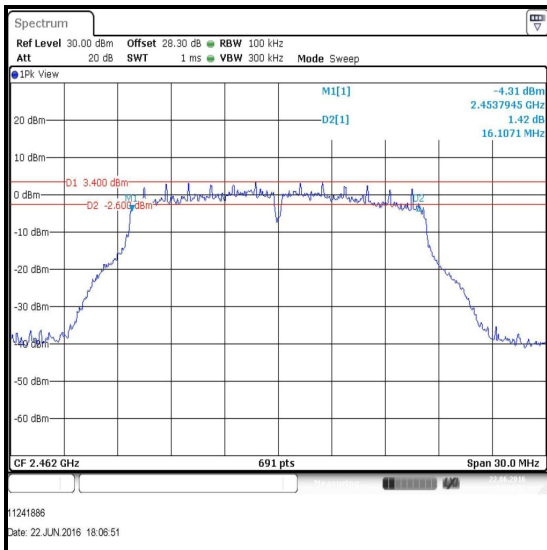

Channel 11

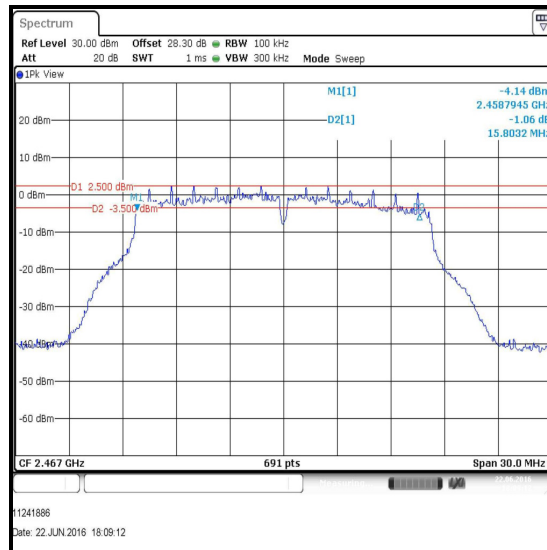

Channel 12

Transmitter Minimum 6 dB Bandwidth (continued)

Results: 802.11g / 20 MHz / BPSK / 6 Mbps

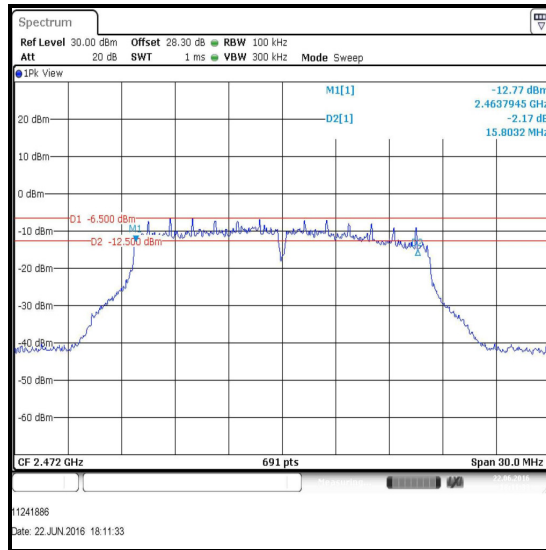

Channel 13

Transmitter Minimum 6 dB Bandwidth (continued)

Results: 802.11n / HT20 / BPSK / MCS0 / SISO

Channel	6 dB Bandwidth (kHz)	Limit (kHz)	Margin (kHz)	Result
1	16411	≥500	15911	Complied
6	17366	≥500	16866	Complied
11	16715	≥500	16215	Complied
12	16454	≥500	15954	Complied
13	16454	≥500	15954	Complied

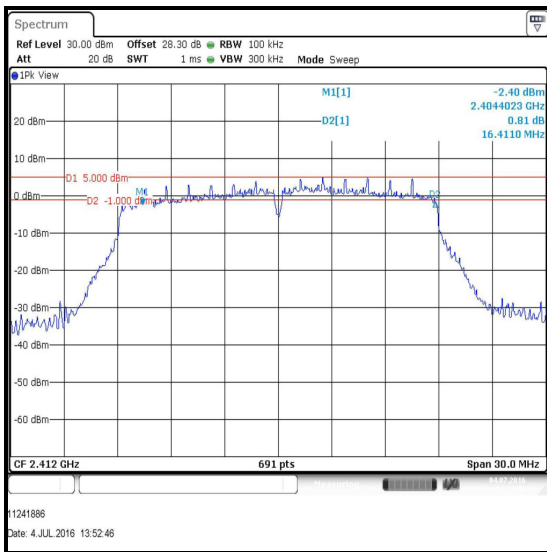

Channel 1

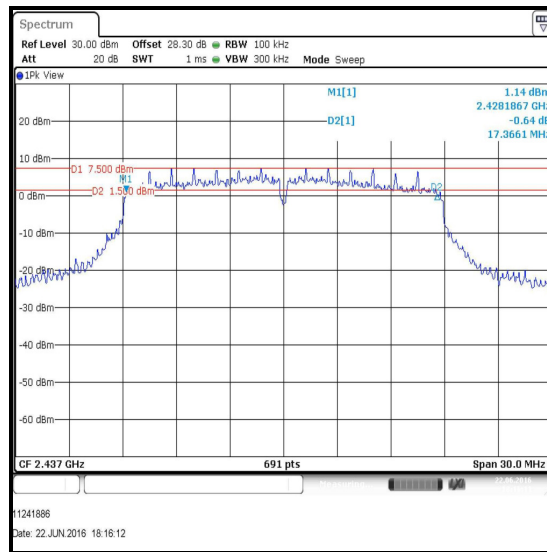

Channel 6

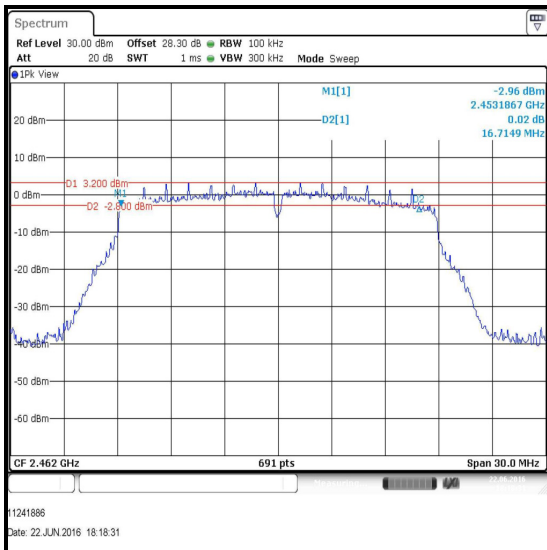

Channel 11

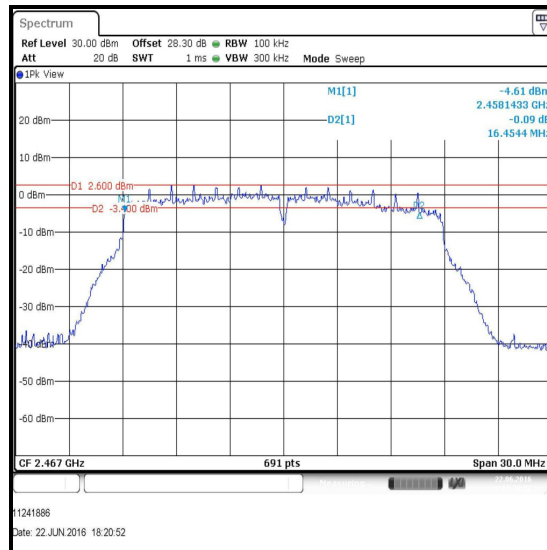

Channel 12

Transmitter Minimum 6 dB Bandwidth (continued)

Results: 802.11n / HT20 / BPSK / MCS0 / SISO

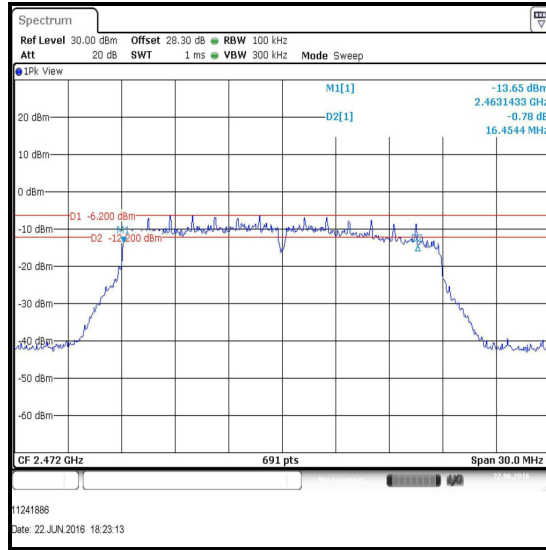

Channel 13

Transmitter Minimum 6 dB Bandwidth (continued)

Results: 802.11n / HT20 / BPSK / MCS0 / MIMO / Port 1

Channel	6 dB Bandwidth (kHz)	Limit (kHz)	Margin (kHz)	Result
1	16411	≥500	15911	Complied
6	16975	≥500	16475	Complied
11	16975	≥500	16475	Complied
12	16585	≥500	16085	Complied
13	16454	≥500	15954	Complied

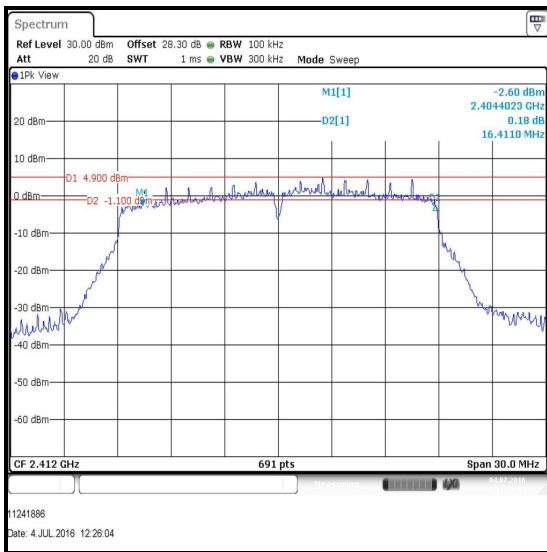

Channel 1

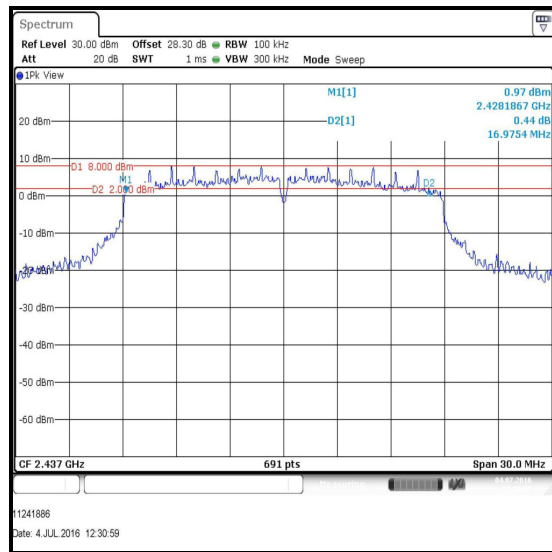

Channel 6

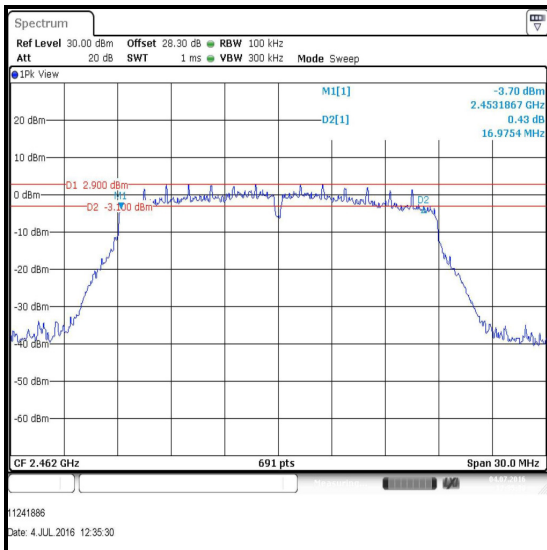

Channel 11

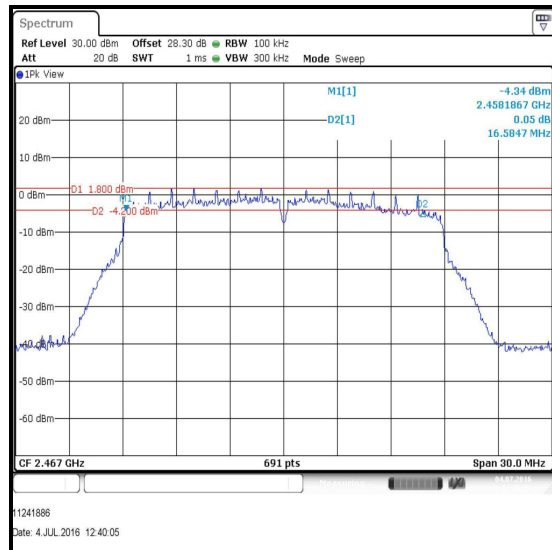

Channel 12

Transmitter Minimum 6 dB Bandwidth (continued)

Results: 802.11n / HT20 / BPSK / MCS0 / MIMO / Port 1

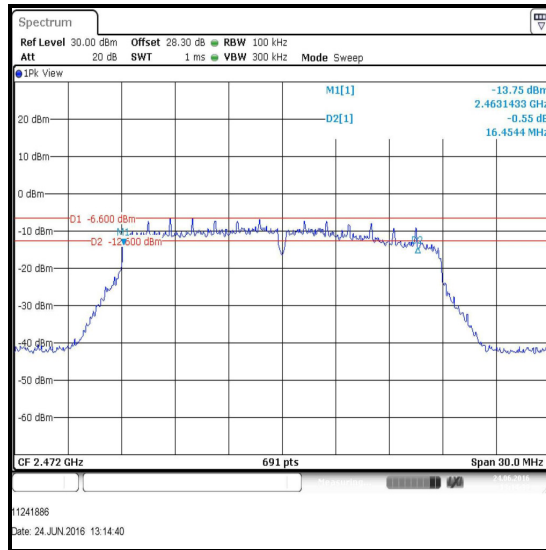

Channel 13

Transmitter Minimum 6 dB Bandwidth (continued)

Results: 802.11n / HT20 / BPSK / MCS0 / MIMO / Port 2

Channel	6 dB Bandwidth (kHz)	Limit (kHz)	Margin (kHz)	Result
1	17019	≥500	16519	Complied
6	17583	≥500	17083	Complied
11	17062	≥500	16562	Complied
12	17670	≥500	17170	Complied
13	17019	≥500	16519	Complied

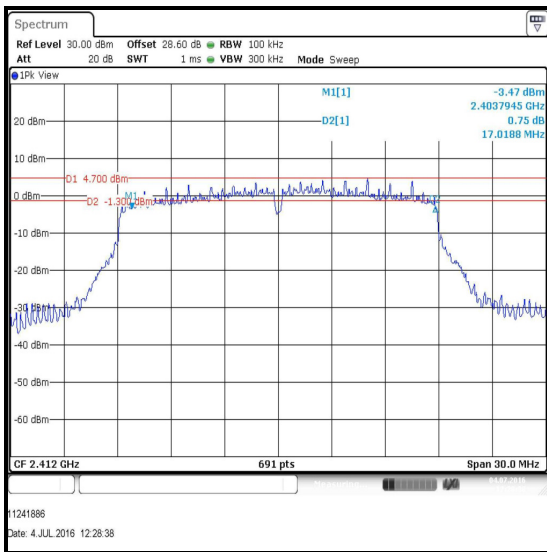

Channel 1

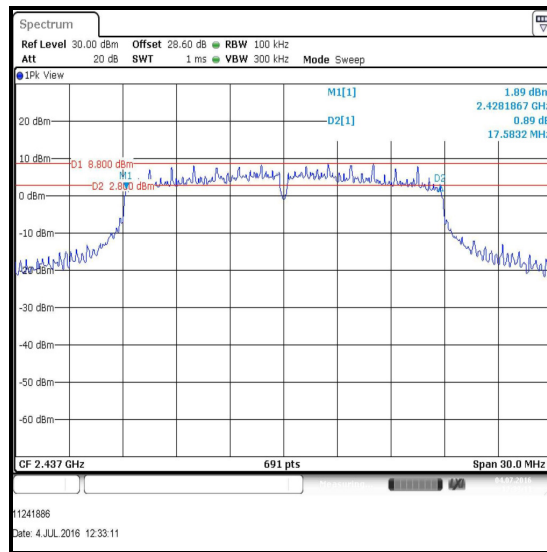

Channel 6

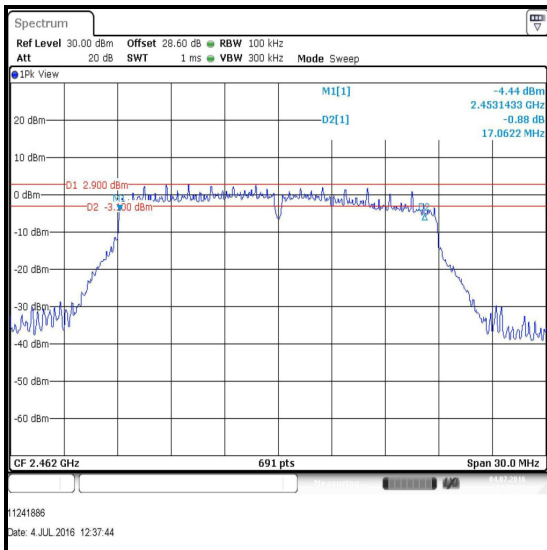

Channel 11

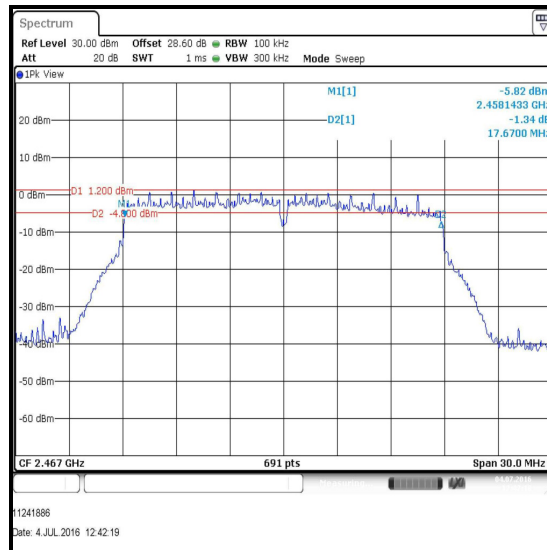

Channel 12

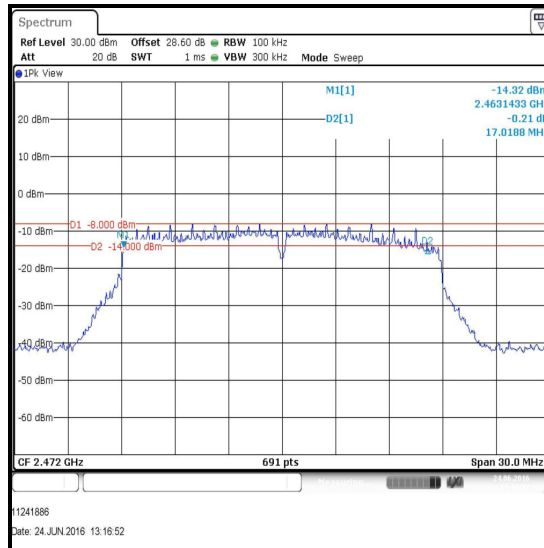
Transmitter Minimum 6 dB Bandwidth (continued)**Results: 802.11n / HT20 / BPSK / MCS0 / MIMO / Port 2****Channel 13****Test Equipment Used:**

Asset No.	Instrument	Manufacturer	Type No.	Serial No.	Date Calibration Due	Cal. Interval (Months)
M1659	Thermohygrometer	JM Handlungspunkt	30.5015.13	None stated	02 Apr 2017	12
M1835	Signal Analyser	Rohde & Schwarz	FSV30	103050	27 Feb 2017	12
M1867	Attenuator	Huber + Suhner AG	6820.17.B	07101	Calibrated before use	-
A2847	Attenuator	Radiall	R411.820.121	24671450	Calibrated before use	-
A2345	Attenuator	Macom	2082-6043-20	None stated	Calibrated before use	-
A2952	RF Switch	Pickering Interfaces	64-102-002 & 40-881-001	XZ361012 & X361507	Calibrated before use	-
S0538	DC Power Supply	TTi	PL154	250135	Calibrated before use	-
M1818	Multimeter	Fluke	79III	71811580	27 Apr 2017	12
M1252	Signal Generator	Hewlett Packard	83640A	3119A00489	26 Oct 2017	24

5.2.2. Transmitter Power Spectral Density

Test Summary:

Test Engineer:	Georgios Vrezas	Test Dates:	22 June 2016 to 04 July 2016
Test Sample Serial Number:	C7CRR02BHCPX		

FCC Reference:	Part 15.247(e)
Test Method Used:	FCC KDB 558074 Section 10.3

Environmental Conditions:

Temperature (°C):	24 to 25
Relative Humidity (%):	36 to 45

Note(s):

- The customer declared the following data rates to be used for all measurements as:
 - 802.11b – DBPSK / 1 Mbps / Port 1
 - 802.11g – BPSK / 6 Mbps / Port 1
 - 802.11n HT20 SISO – BPSK / 6.5 Mbps / MCS0 / Port 1
 - 802.11n HT20 MIMO – BPSK / 6.5 Mbps / MCS0
- Final measurements were performed using the above configurations on the relevant channels.
- The EUT was transmitting at ≥98% duty cycle and testing was performed in accordance with KDB 558074 Section 10.3 Method AVGPS-1. The signal analyser resolution bandwidth was set to 100 kHz and video bandwidth 300 kHz. An RMS detector was used and sweep time set manually to perform trace averaging over 300 traces. The span was set to at least 1.5 times the 99% occupied emission bandwidth (see Appendix 1 for reference plots). The highest peak of the measured signal was recorded.
- For 802.11n MIMO, PSD was measured on both ports and then combined using the *measure and sum spectral maxima across the outputs* technique, stated in FCC KDB 662911 D01 Section E)2)b).
- The signal analyser was connected to the RF port on the EUT using an RF switch, suitable attenuation and RF cables.

Test setup:

