

Certification Test Report

FCC ID: AZ492FT7089
IC: 109U-92FT7089

FCC Rule Part: 15.247
ISED Canada Radio Standards Specification: RSS-247

ACS Report Number: 16-2041.W06.1C

Applicant: Motorola Solutions

Model(s): M37TSS9PW1AN

Test Begin Date: **August 11, 2016**
Test End Date: **September 2, 2016**

Report Issue Date: November 8, 2016



FOR THE SCOPE OF ACCREDITATION UNDER CERTIFICATE NUMBER AT-1533

This report must not be used by the client to claim product certification, approval, or endorsement by ANAB, ANSI, or any agency of the Federal Government.

Prepared by:



Thierry Jean-Charles
EMC Engineer
Advanced Compliance Solutions, Inc.

Reviewed by:



Ryan McGann
Wireless Program Manager
Advanced Compliance Solutions, Inc.

This test report shall not be reproduced except in full. This report may be reproduced in part with prior written consent of ACS, Inc. The results contained in this report are representative of the sample(s) submitted for evaluation.

This report contains 30 pages

TABLE OF CONTENTS

| | | |
|-------|--|----|
| 1 | GENERAL | 3 |
| 1.1 | Purpose | 3 |
| 1.2 | Applicant Information | 3 |
| 1.3 | Product Description | 3 |
| 1.4 | Test Methodology and Considerations | 3 |
| 2 | TEST FACILITIES | 4 |
| 2.1 | Location | 4 |
| 2.2 | Laboratory Accreditations/Recognitions/Certifications..... | 4 |
| 2.3 | Radiated & Conducted Emissions Test Site Description | 5 |
| 2.3.1 | Semi-Anechoic Chamber Test Site | 5 |
| 2.3.2 | Conducted Emissions Test Site Description..... | 6 |
| 3 | APPLICABLE STANDARD REFERENCES | 7 |
| 4 | LIST OF TEST EQUIPMENT | 8 |
| 5 | SUPPORT EQUIPMENT | 9 |
| 6 | EQUIPMENT UNDER TEST SETUP BLOCK DIAGRAM..... | 10 |
| 7 | SUMMARY OF TESTS..... | 11 |
| 7.1 | Antenna Requirement – FCC: Section 15.203..... | 11 |
| 7.2 | 6 dB Bandwidth - FCC: Section 15.247(a)(2); ISED Canada: RSS-247 5.2(1); 99% Bandwidth ISED Canada: RSS-GEN 6.6..... | 11 |
| 7.2.1 | Measurement Procedure..... | 11 |
| 7.2.2 | Measurement Results | 11 |
| 7.3 | Peak Output Power - FCC Section 15.247(b)(3); ISED Canada: RSS-247 5.4(4)..... | 15 |
| 7.3.1 | Measurement Procedure (Conducted Method) | 15 |
| 7.3.2 | Measurement Results | 15 |
| 7.4 | Band-Edge and Spurious Emissions | 17 |
| 7.4.1 | Band-Edge Compliance of RF Conducted Emissions - FCC Section 15.247(d); ISED Canada: RSS-247 5.5..... | 17 |
| 7.4.2 | RF Conducted Spurious Emissions - FCC Section 15.247(d); ISED Canada: RSS-247 5.5..... | 19 |
| 7.4.3 | Radiated Spurious Emissions into Restricted Frequency Bands – FCC Sections 15.205, 15.209; ISED Canada: RSS-Gen 8.9, 8.10 | 23 |
| 7.5 | Power Spectral Density - FCC Section 15.247(e); ISED Canada: RSS-247 5.2(2)..... | 25 |
| 7.5.1 | PSD Measurement Procedure (Conducted Method)..... | 25 |
| 7.5.2 | Measurement Results | 25 |
| 7.6 | Power Line Conducted Emissions – FCC: Section 15.207; ISED Canada: RSS-Gen 8.8..... | 27 |
| 7.6.1 | Measurement Procedure | 27 |
| 7.6.2 | Measurement Results | 27 |
| 8 | CONCLUSION..... | 30 |

1 GENERAL

1.1 Purpose

The purpose of this report is to demonstrate compliance with Part 15 Subpart C of the FCC's Code of Federal Regulations and Innovation, Science and Economic Development Canada's Radio Standards Specification RSS-247 for the tests documented herein.

1.2 Applicant Information

Motorola Solutions
8000 West Sunrise Blvd
Sunrise, FL 33322

1.3 Product Description

The Motorola Solutions, Inc, APX8500 model M37TSS9PW1AN is a two-way mobile radio, which supports multiple land mobile radio bands such as VHF, UHF and 7/800 MHz. Additionally, the equipment provides 2.4 GHz 802.11b/g/n Wi-Fi as well as a Bluetooth Classic and Bluetooth Low Energy (BLE) capabilities. The test report documents the evaluation of the Bluetooth Low Energy transceiver.

Technical Details

Mode of Operation: Bluetooth Low Energy (BLE)
Frequency Range: 2402 MHz - 2480 MHz
Number of Channels: 40
Channel Separation: 2 MHz
Modulations: GFSK
Antenna Type/Gain: Monopole, 5.15 dBi
Input Power: 15 VDC Power Supply

Model Number: M37TSS9PW1AN

Test Sample Serial Number(s): AM3C573

Test Sample Condition: The equipment was provided in good condition without any physical damage.

1.4 Test Methodology and Considerations

The EUT was evaluated for radiated, power line and RF conducted measurements for the Bluetooth Low Energy radio using test software power setting 24.

For the RF conducted measurements, the EUT was coupled to a spectrum analyzer to a QMA to SMA adapter and suitable attenuation.

The EUT was evaluated for radiated emissions up to the 10th harmonic of the fundamental frequency in the orientation of typical installation. A counterpoise of 1m diameter was provided for the evaluation.

The EUT was also investigated for unintentional emissions. The results are documented separately in a verification test report.

2 TEST FACILITIES

2.1 Location

The radiated and conducted emissions test sites are located at the following address:

Advanced Compliance Solutions, Inc.
3998 FAU Blvd, Suite 310
Boca Raton, Florida 33431
Phone: (561) 961-5585
Fax: (561) 961-5587
www.acstestlab.com

FCC Test Firm Registration #: 475089
Innovation, Science and Economic Development Canada Lab Code: 4175C

2.2 Laboratory Accreditations/Recognitions/Certifications

ACS is accredited to ISO/IEC 17025 by ANSI-ASQ National Accreditation Board under their ANAB program and has been issued certificate number AT-1533 in recognition of this accreditation. Unless otherwise specified, all test methods described within this report are covered under the ISO/IEC 17025 scope of accreditation.

2.3 Radiated & Conducted Emissions Test Site Description

2.3.1 Semi-Anechoic Chamber Test Site

The EMC radiated test facility consists of an RF-shielded enclosure. The interior dimensions of the indoor semi-anechoic chamber are approximately 48 feet (14.6 m) long by 36 feet (10.8 m) wide by 24 feet (7.3 m) high and consist of rigid, 1/8 inch (0.32 cm) steel-clad, wood core modular panels with steel framing. In the shielded enclosure, the faces of the panels are galvanized and the chamber is self-supporting. 8-foot RF absorbing cones are installed on 4 walls and the ceiling. The steel-clad ground plane is covered with vinyl flooring.

The turntable is driven by pneumatic motor, which is capable of supporting a 2000 lb. load. The turntable is flush with the chamber floor which it is connected to, around its circumference, with a continuous metallic loaded spring. An EMCO Model 1060 Multi-device controller controls the turntable position.

A pneumatic motor is used to control antenna polarizations and height relative to the ground. The height information is displayed on the control unit EMCO Model 1050.

The control room is an RF shielded enclosure attached to the semi-anechoic chamber with two bulkhead panels for connecting RF, and control cables. The dimension of the room is 7.3 m x 4.9 m x 3 m high and the entrance doors of both control and conducted rooms are 3 feet (0.91 m) by 7 feet (2.13 m).

A diagram of the Semi-Anechoic Chamber Test Site is shown in Figure 2.3.1-1 below:

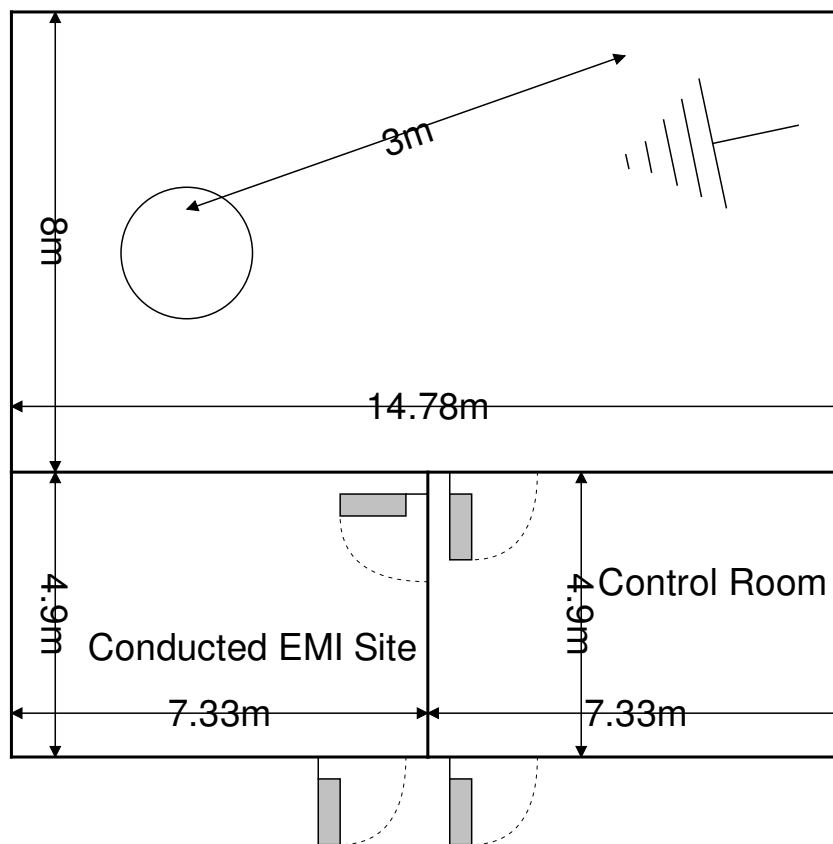

Figure 2.3.1-1: Semi-Anechoic Chamber Test Site

2.3.2 Conducted Emissions Test Site Description

The dimensions of the shielded conducted room are 7.3 x 4.9 x 3 m³. The power line conducted emission site includes two LISNs: a Solar Model 8028-50 50 Ω/50 μH and an EMCO Model 3825/2R, which are installed as shown in the figure below. For evaluations requiring 230 V, 50 Hz AC input, a Polarad LISN (S/N 879341/048) is used in conjunction with a California Instruments signal generator Model 2001RP-OP1.

A diagram of the room is shown below in figure 2.3.2-1:

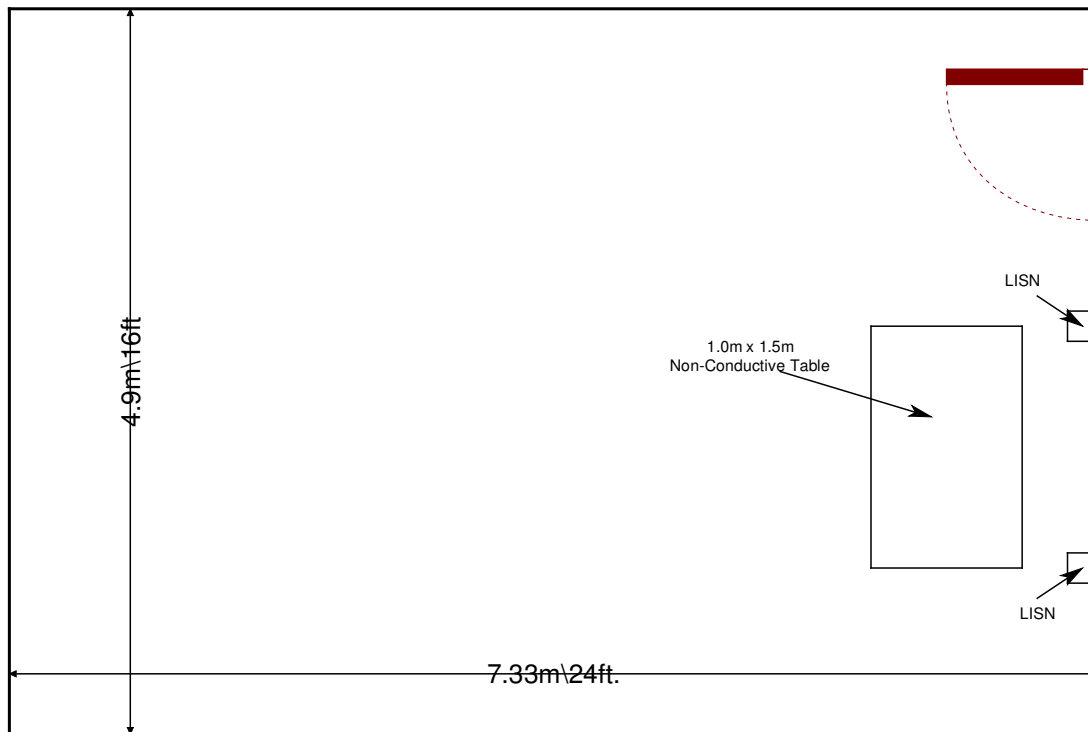

Figure 2.3.2-1: AC Mains Conducted EMI Site

3 APPLICABLE STANDARD REFERENCES

The following standards were used:

- ❖ ANSI C63.4-2014: Method of Measurements of Radio-Noise Emissions from Low-Voltage Electrical and Electronic Equipment in the 9 kHz to 40 GHz.
- ❖ ANSI C63.10-2013: American National Standard of Procedures for Compliance Testing of Unlicensed Wireless Devices
- ❖ US Code of Federal Regulations (CFR): Title 47, Part 2, Subpart J: Equipment Authorization Procedures, 2016.
- ❖ US Code of Federal Regulations (CFR): Title 47, Part 15, Subpart C: Radio Frequency Devices, Intentional Radiators, 2016
- ❖ FCC KDB 558074 D01 DTS Meas Guidance v03r05 - Guidance for Performing Compliance Measurements on Digital Transmission Systems (DTS) Operating Under §15.247, April 8, 2016.
- ❖ Innovation, Science and Economic Development Canada Radio Standards Specification: RSS-247 — Digital Transmission Systems (DTSS), Frequency Hopping Systems (FHSs) and Licence-Exempt Local Area Network (LE-LAN) Devices, Issue 1, May 2015.
- ❖ Innovation, Science and Economic Development Canada Radio Standards Specification: RSS-GEN – General Requirements for Compliance of Radio Apparatus, Issue 4, November 2014.

4 LIST OF TEST EQUIPMENT

The calibration interval of test equipment is annually or the manufacturer's recommendations. Where the calibration interval deviates from the annual cycle based on the instrument manufacturer's recommendations, it shall be stated below.

Table 4-1: Test Equipment

Table 4-1: Test Equipment List

| AssetID | Manufacturer | Model # | Equipment Type | Serial # | Last Calibration Date | Calibration Due Date |
|---------|----------------------------|------------------------|--------------------|------------|-----------------------|----------------------|
| 78 | EMCO | 6502 | Antennas | 9104-2608 | 5/11/2016 | 5/11/2018 |
| 283 | Rohde & Schwarz | FSP40 | Spectrum Analyzers | 1000033 | 7/21/2016 | 7/21/2018 |
| 523 | Agilent | E7405 | Spectrum Analyzers | MY45103293 | 12/26/2014 | 12/26/2016 |
| 653 | Suhner | SF-102A | Cables | 0944/2A | 9/15/2015 | 9/15/2016 |
| 2002 | EMCO | 3108 | Antennas | 2147 | 11/19/2015 | 11/19/2017 |
| 2004 | EMCO | 3146 | Antennas | 1385 | 11/19/2015 | 11/19/2017 |
| 2006 | EMCO | 3115 | Antennas | 2573 | 4/14/2015 | 4/14/2017 |
| 2008 | COM-Power | AH-826 | Antennas | 81009 | NCR | NCR |
| 2011 | Hewlett-Packard | HP 8447D | Amplifiers | 2443A03952 | 11/18/2015 | 11/18/2016 |
| 2022 | EMCO | LISN3825/2R | LISN | 1095 | 9/14/2015 | 9/14/2017 |
| 2045 | ACS Boca | Conducted Cable Set | Cable Set | 2045 | 11/11/2015 | 11/11/2016 |
| 2070 | Mini Circuits | VHF-8400+ | Filter | 2070 | 11/17/2015 | 11/17/2016 |
| 2072 | Mini Circuits | VHF-3100+ | Filter | 30737 | 11/17/2015 | 11/17/2016 |
| 2082 | Teledyne Storm Products | 90-010-048 | Cables | 2082 | 4/21/2016 | 4/21/2017 |
| 2086 | Merrimac | FAN-6-10K | Attenuators | 23148-83-1 | 11/16/2015 | 11/16/2016 |
| 2089 | Agilent Technologies, Inc. | 83017A | Amplifiers | 3123A00214 | 12/9/2015 | 12/9/2016 |
| 2095 | ETS Lindgren | TILE4! - Version 4.2.A | Software | 85242 | NCR | NCR |
| 2111 | Aeroflex Inmet | 40AH2W-20 | Attenuator | 2111 | 7/20/2016 | 7/20/2017 |
| 2112 | Teledyne Storm Products | 921-0101-036 | Cables | 12-06-698 | 11/13/2015 | 11/13/2016 |
| 2121 | ACS Boca | Radiated Cable Set | Cable Set | 2121 | 8/1/2016 | 8/1/2017 |
| 3004 | Teseq | CFL 9206A | Attenuators | 34720 | 10/7/2015 | 10/7/2016 |

Note: NCR=No Calibration Required

5 SUPPORT EQUIPMENT

Table 5-1: EUT and Support Equipment Description

| Item # | Type Device | Manufacturer | Model/Part # | Serial # |
|--------|---------------------|--------------|---------------|-------------------------------|
| 1 | EUT | Motorola | M37TSS9PW1AN | AM3C573 |
| 2 | Microphone | Motorola | HMN1090A | N/A |
| 3 | Speaker | Motorola | HSN4038A | N/A |
| 4 | LMR Antenna | Motorola | AN000131A01 | 562948 |
| 5 | WiFi/BT/GPS Antenna | Motorola | AN000163A01 | N/A |
| 6 | 15 VDC Power Supply | Motorola | PS000280A01 | EB58704875 |
| 7 | Laptop | DELL | Latitude D531 | CN-0XM006-48643-789-2125 |
| 8 | Laptop AC Adapter | DELL | LA65NS2-01 | CN-06TM1C-72438-358- 218F-A01 |
| 9 | Mouse | DELL | M-UARDEL7 | LZ9440C43W5 |

Table 5-2: Cable Description

| Cable # | Cable Type | Length | Shield | Termination |
|---------|----------------------|--------|--------|---------------------------------------|
| A | USB | 1.39 m | No | EUT to Laptop |
| B | Coil Microphone | 3.05 m | No | EUT to Microphone |
| C | Audio | 2.82 m | No | EUT to Speaker |
| D | Coaxial | 5.12 m | Yes | LMR Antenna to EUT |
| E | Coaxial | 5.08 m | Yes | Wi-Fi/BT Antenna to EUT |
| F | Coaxial | 5.06 m | Yes | GPS Antenna to EUT |
| G | Power | 1.17 m | No | EUT to 15 VDC Power Supply |
| H | Power | 2.28 m | No | 15 VDC Power Supply to extension Cord |
| I | Extension Power Cord | 2.7 m | No | Power Cord to AC Mains |
| J | Ignition Wire | 3.09 m | No | Not Terminated |
| K | USB | 1.8 m | No | Laptop to Mouse |
| L | Power | 1.85 m | No | Laptop to AC Adapter |
| M | Power | 0.90 m | No | Laptop AC Adapter to AC Mains |

Note: Item I was not used for the power line conducted emissions evaluation.

6 EQUIPMENT UNDER TEST SETUP BLOCK DIAGRAM

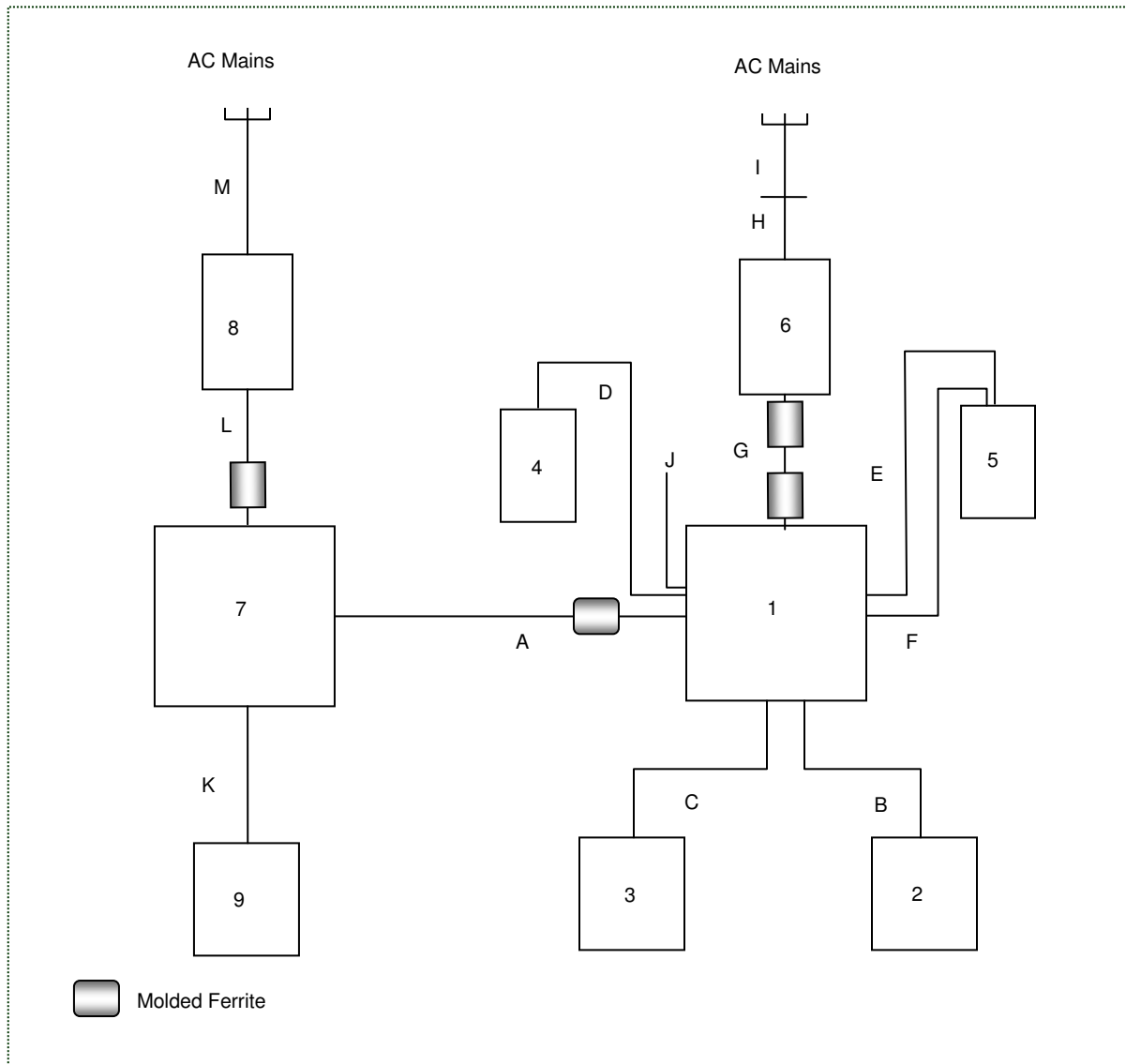

Figure 6-1: EUT Test Setup

7 SUMMARY OF TESTS

Along with the tabular data shown below, plots were taken of all signals deemed important enough to document.

7.1 Antenna Requirement – FCC: Section 15.203

The EUT and the applicable 5.15 dBi monopole antenna use a QMA connector for the 2.4 GHz ISM radio. The antenna connector is unique thus meeting the requirements of FCC Section 15.203.

7.2 6 dB Bandwidth - FCC: Section 15.247(a)(2); ISED Canada: RSS-247 5.2(1); 99% Bandwidth ISED Canada: RSS-GEN 6.6

7.2.1 Measurement Procedure

The 6dB bandwidth was measured in accordance with the FCC KDB 558074 D01 DTS Meas Guidance v03r05 Section 8.2 Option 2. The RBW of the spectrum analyzer was set to 100 kHz and VBW 300 kHz. Span was set large enough to capture the emissions and >> RBW.

The 99% occupied bandwidth was measured with the spectrum analyzer span set to fully display the emission. The RBW was set to 1% to 5% of the approximated bandwidth. The occupied 99% bandwidth was measured by using 99% bandwidth equipment function of the spectrum analyzer.

7.2.2 Measurement Results

Results are shown below.

Table 7.2.2-1: 6dB / 99% Bandwidth

| Frequency [MHz] | 6dB Bandwidth [kHz] | 99% Bandwidth [kHz] |
|-----------------|---------------------|---------------------|
| 2402 | 760.00 | 1050.00 |
| 2440 | 756.00 | 1050.00 |
| 2480 | 756.00 | 1050.00 |

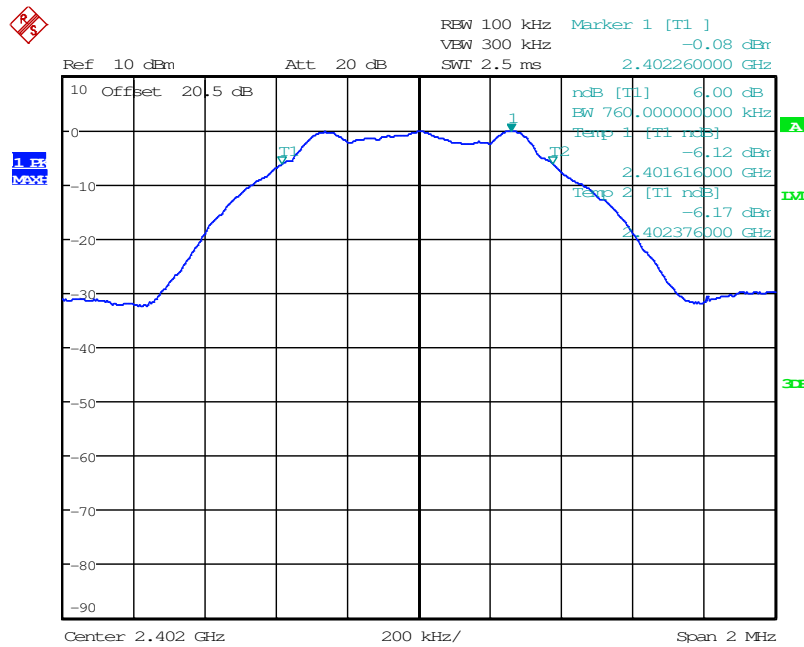

Date: 25.AUG.2016 13:26:37

Figure 7.2.2-1: 6dB BW - Low Channel

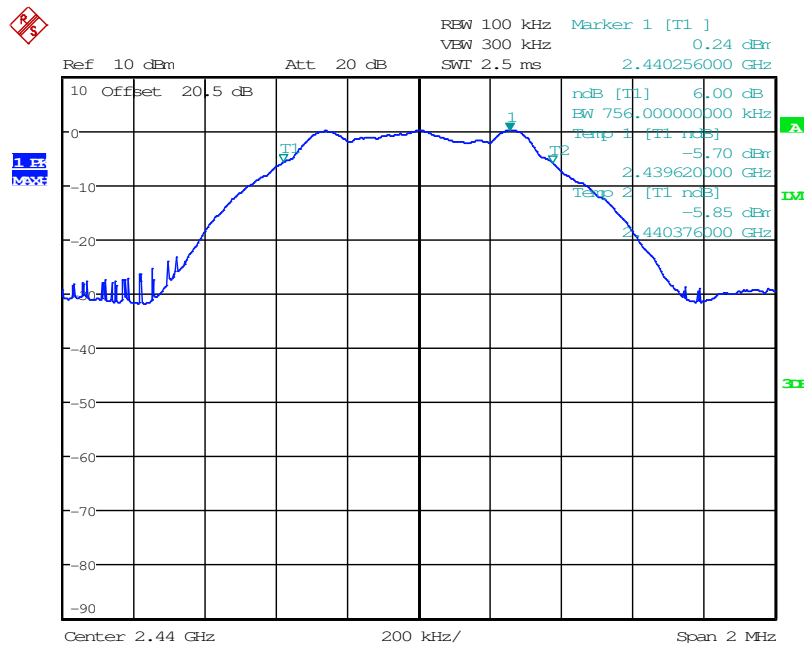

Date: 25.AUG.2016 13:54:29

Figure 7.2.2-2: 6dB BW - Middle Channel

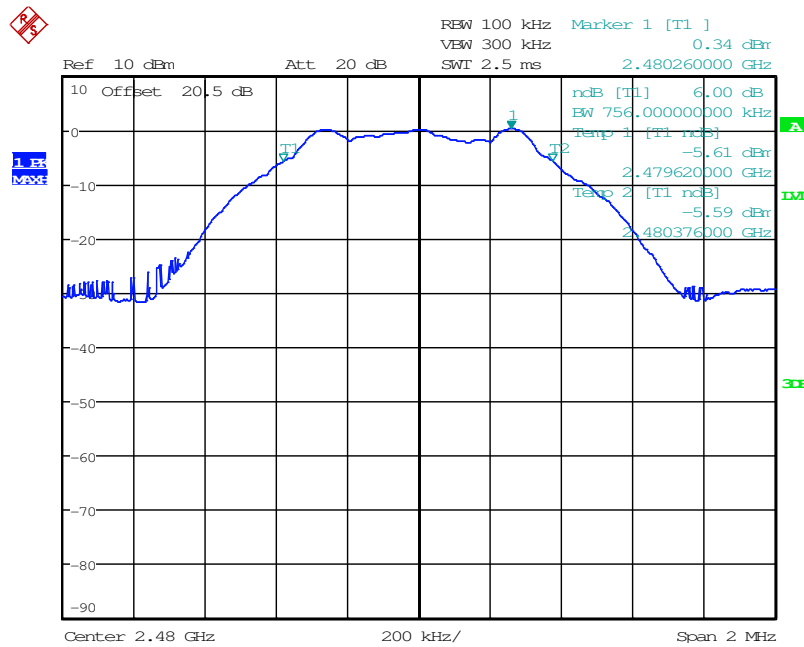

Date: 25.AUG.2016 14:00:03

Figure 7.2.2-3: 6dB BW - High Channel

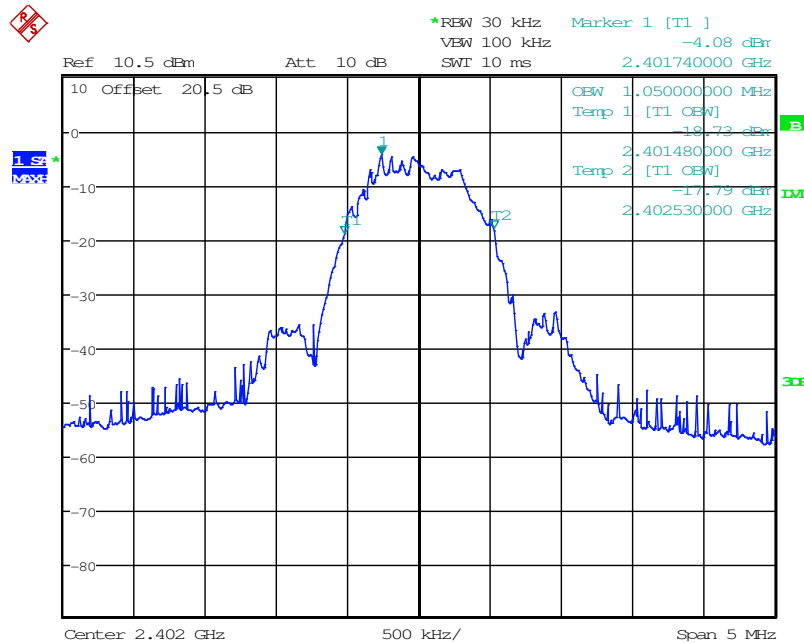

Date: 25.AUG.2016 13:47:07

Figure 7.2.2-4: 99% OBW - Low Channel

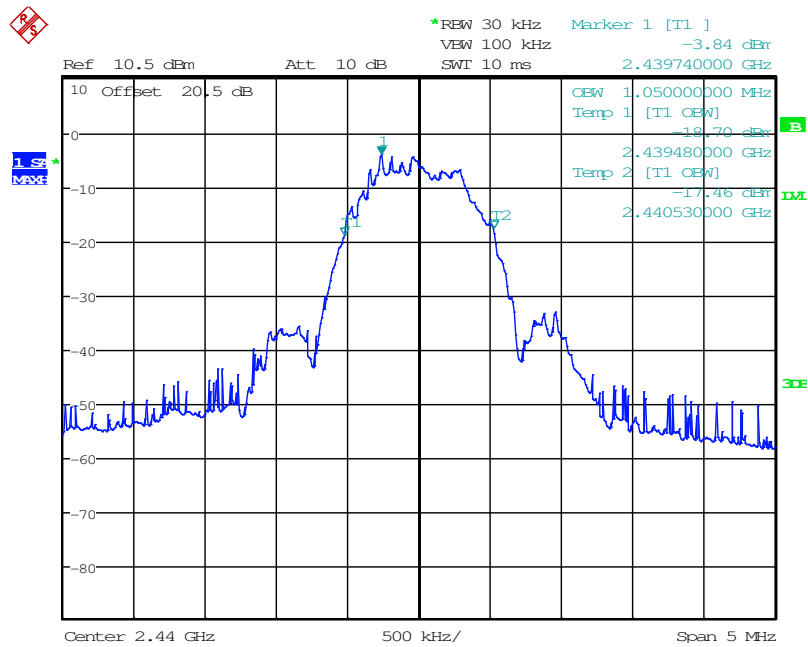

Date: 25.AUG.2016 13:49:18

Figure 7.2.2-5: 99% OBW - Middle Channel

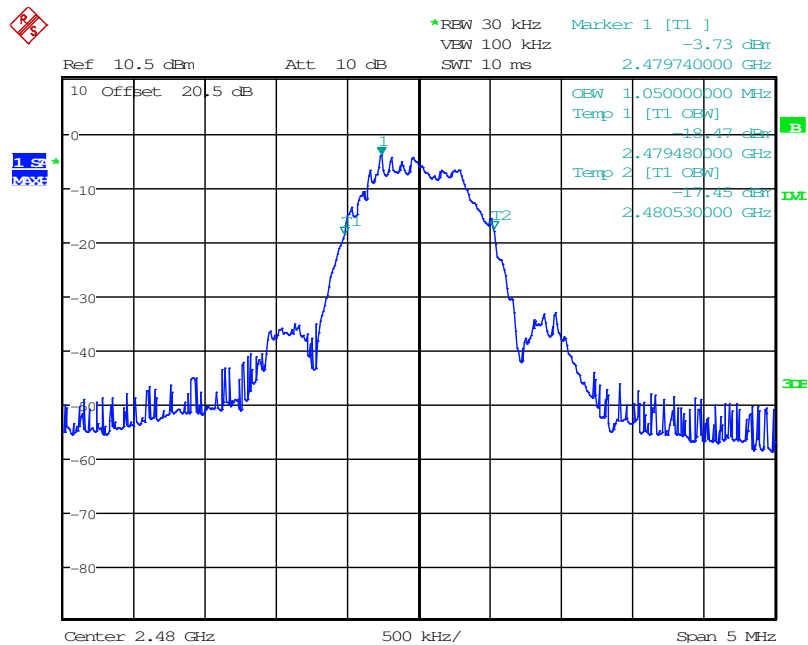

Date: 25.AUG.2016 14:02:15

Figure 7.2.2-6: 99% OBW - High Channel

7.3 Peak Output Power - FCC Section 15.247(b)(3); ISED Canada: RSS-247 5.4(4)

7.3.1 Measurement Procedure (Conducted Method)

The fundamental emission output power was measured in accordance with the FCC KDB 558074 D01 DTS Meas Guidance v03r05 Section 9.1.1 RBW \geq DTS bandwidth. The RF output of the equipment under test was directly connected to the input of the spectrum analyzer through suitable attenuation.

7.3.2 Measurement Results

Results are shown below.

Table 7.3.2-1: RF Output Power

| Frequency [MHz] | Level [dBm] |
|-----------------|-------------|
| 2402 | 0.97 |
| 2440 | 1.58 |
| 2480 | 1.61 |

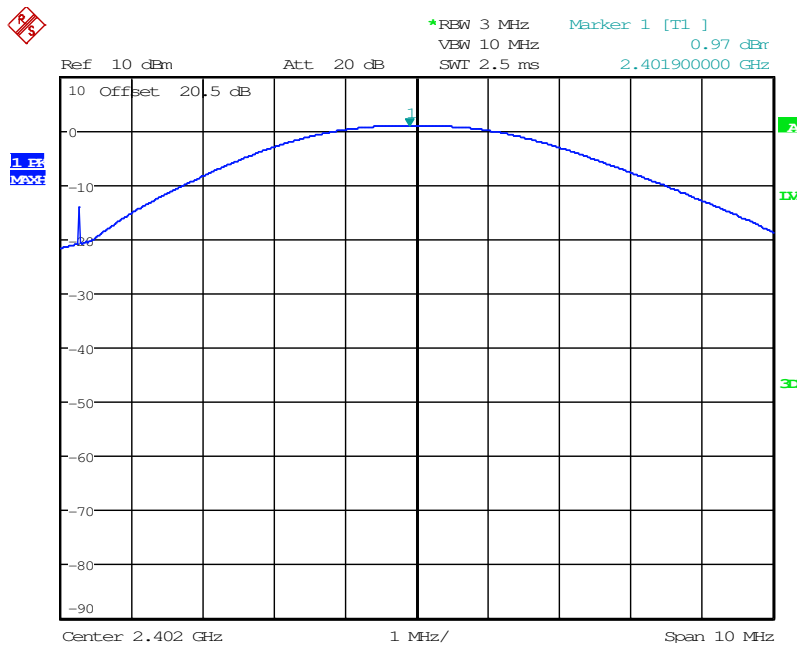

Date: 25.AUG.2016 14:13:02

Figure 7.3.2-1: RF Output Power - Low Channel

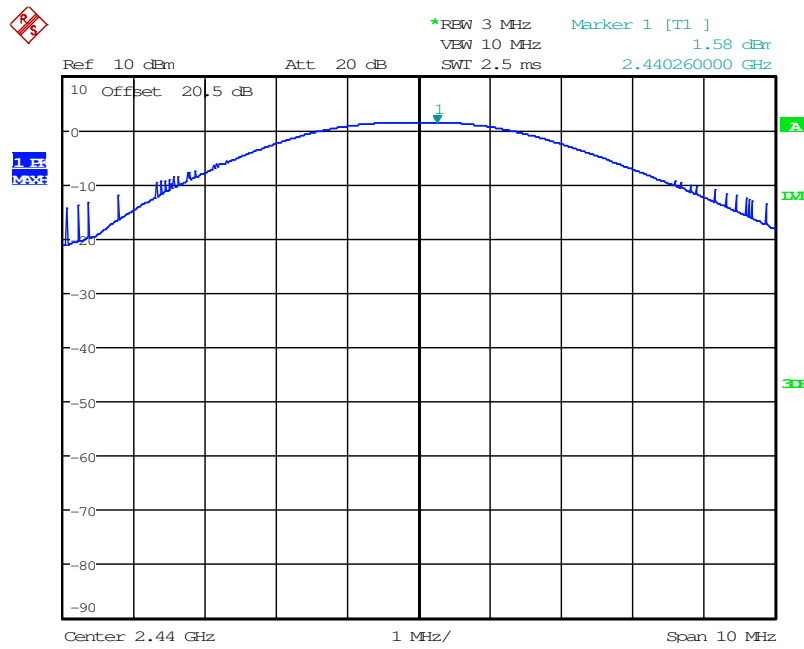

Date: 29.AUG.2016 16:19:08

Figure 7.3.2-2: RF Output Power - Middle Channel

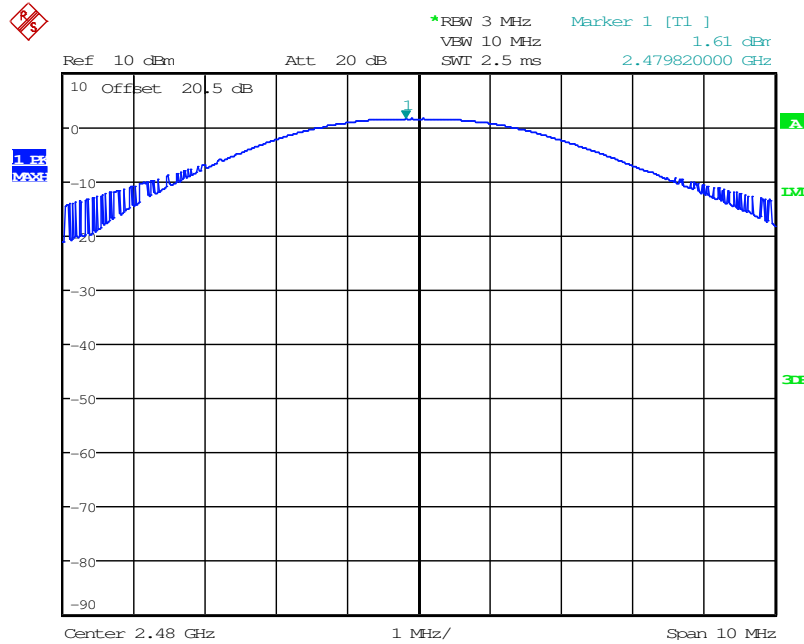

Date: 29.AUG.2016 16:43:01

Figure 7.3.2-3: RF Output Power - High Channel

7.4 Band-Edge and Spurious Emissions

7.4.1 Band-Edge Compliance of RF Conducted Emissions - FCC Section 15.247(d); ISED Canada: RSS-247 5.5

7.4.1.1 Measurement Procedure

The RF output port of the EUT was directly connected to the input of the spectrum analyzer via suitable attenuation. The EUT was investigated at the lowest and highest channel available to determine band-edge compliance. For each measurement the spectrum analyzer's RBW was set to 100 kHz, and the VBW was set to 300 kHz.

7.4.1.2 Measurement Results

Results are shown below.

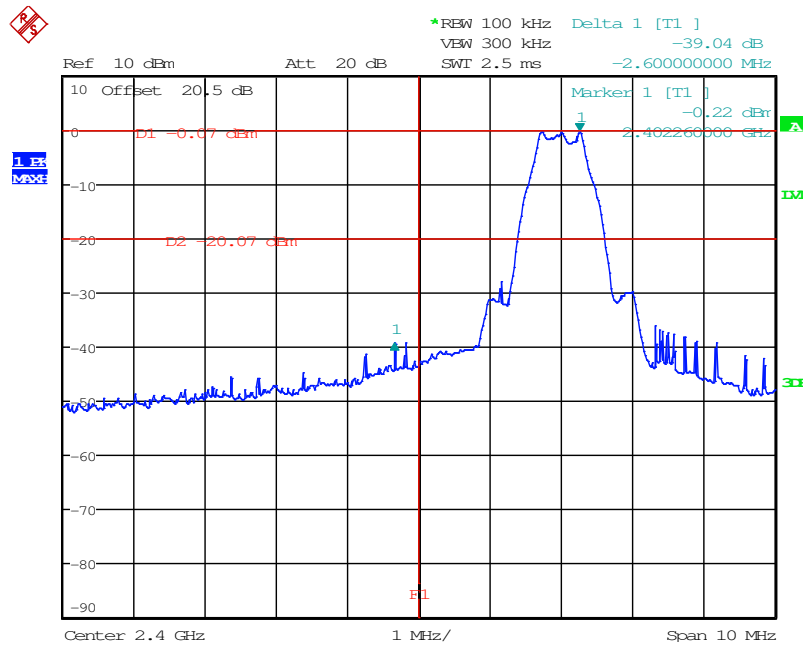

Date: 29.AUG.2016 19:09:34

Figure 7.4.1.2-1: Lower Band-edge

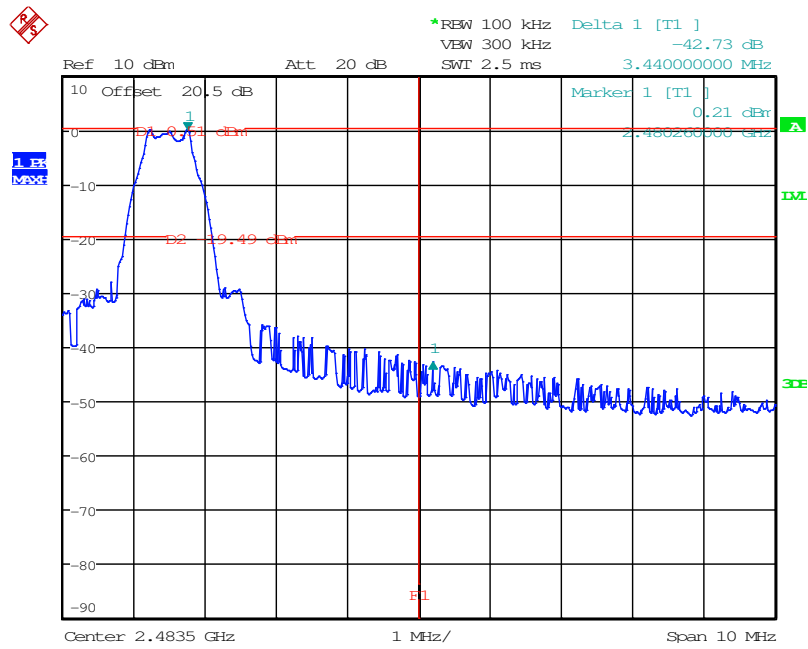

Date: 29.AUG.2016 19:02:33

Figure 7.4.1.2-2: Upper Band-edge

7.4.2 RF Conducted Spurious Emissions - FCC Section 15.247(d); ISED Canada: RSS-247 5.5

7.4.2.1 Measurement Procedure

The RF Conducted Spurious Emissions were measured in accordance with the FCC KDB 558074 D01 DTS Meas Guidance v03r05 Section 11.3 Emission level measurement. The RF output port of the equipment under test was directly connected to the input of the spectrum analyzer. The EUT was investigated for conducted spurious emissions from 30MHz to 26 GHz, 10 times the highest fundamental frequency. Measurements were made at the low, center and high channels of the EUT. For each measurement, the spectrum analyzer's RBW was set to 100 kHz and the VBW was set to 300 kHz. The peak Max Hold function of the analyzer was utilized. The reference level was determined by measuring the Peak PSD level in any 100 kHz bandwidth within the DTS channel bandwidth.

7.4.2.2 Measurement Results

Results are shown below.

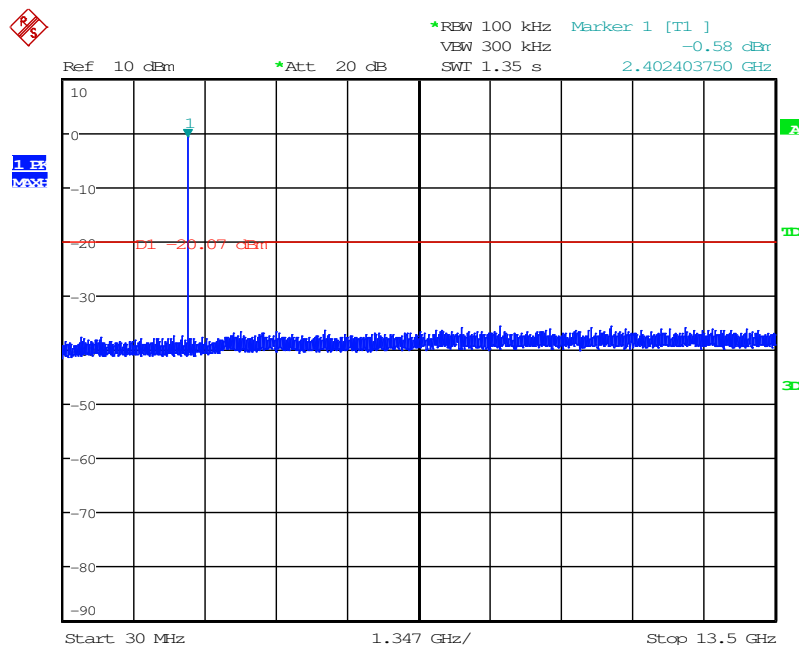

Date: 29.AUG.2016 18:35:31

Figure 7.4.2.2-1: 30 MHz – 13.5 GHz – Low Channel

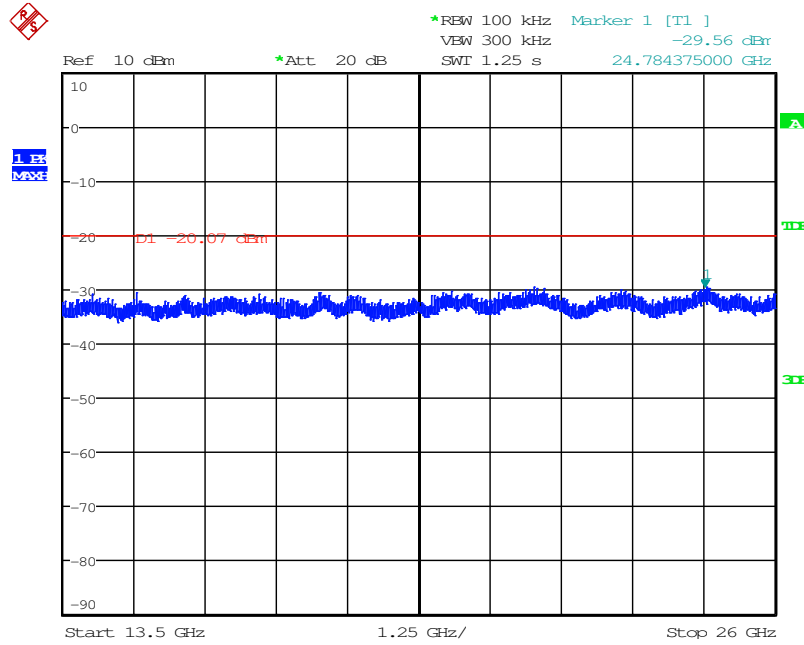

Date: 29.AUG.2016 18:38:16

Figure 7.4.2.2-2: 13.5 GHz –26 GHz – Low Channel

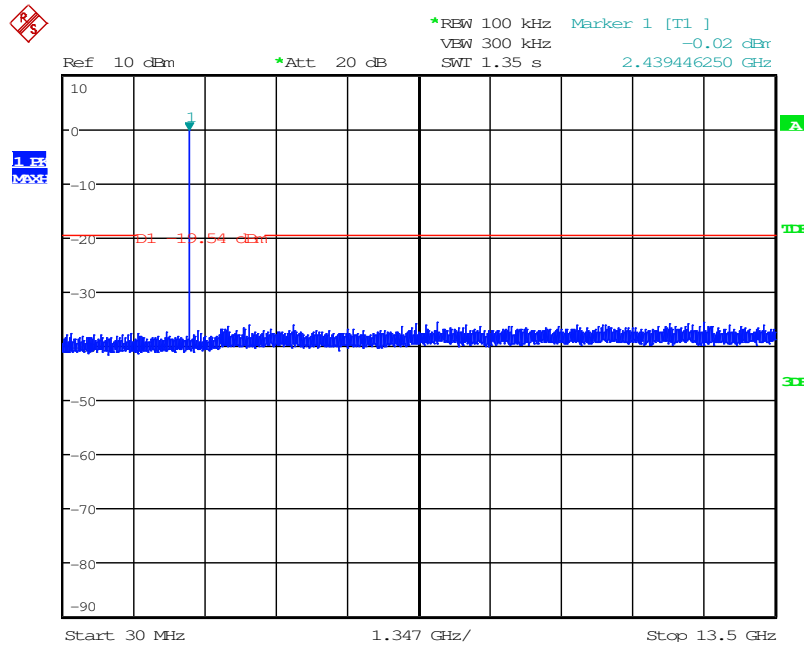

Date: 29.AUG.2016 18:42:51

Figure 7.4.2.2-3: 30 MHz – 13.5 GHz –Middle Channel

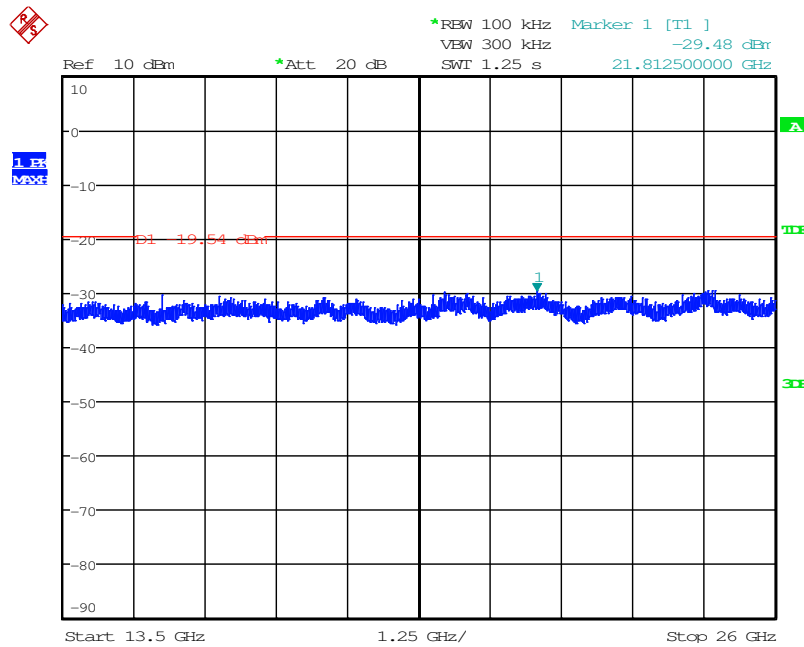

Date: 29.AUG.2016 18:45:53

Figure 7.4.2.2-4: 13.5 GHz –26 GHz – Middle Channel

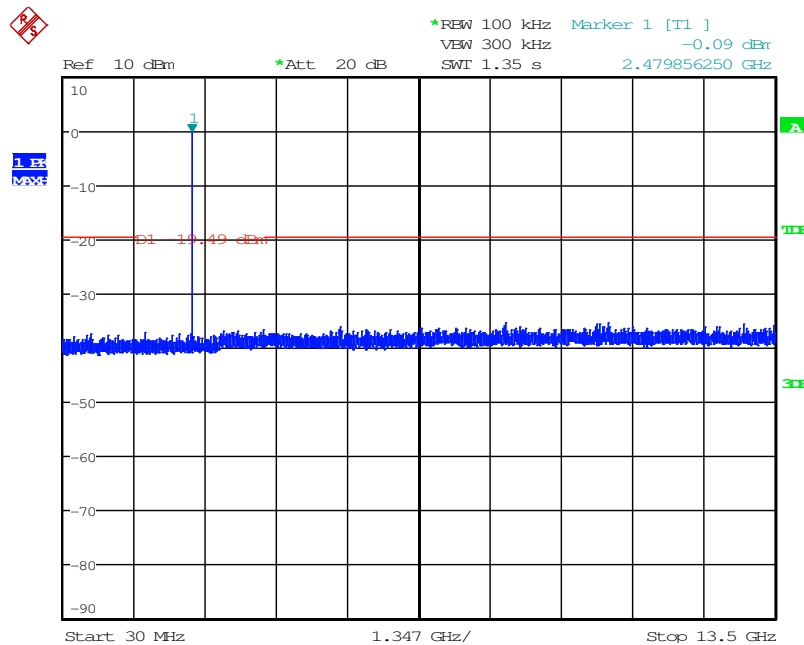

Date: 29.AUG.2016 18:51:08

Figure 7.4.2.2-5: 30 MHz – 13.5 GHz – High Channel

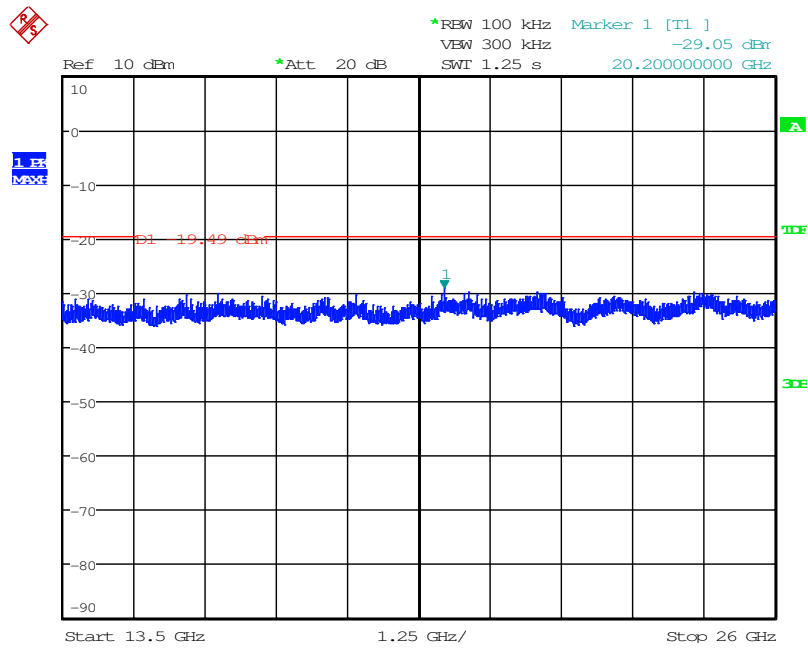

Date: 29.AUG.2016 18:53:20

Figure 7.4.2.2-6: 13.5 GHz –26 GHz –High Channel

7.4.3 Radiated Spurious Emissions into Restricted Frequency Bands – FCC Sections 15.205, 15.209; ISED Canada: RSS-Gen 8.9, 8.10

7.4.3.1 Measurement Procedure

Radiated emissions tests were made over the frequency range of 9 kHz to 26 GHz, 10 times the highest fundamental frequency. Each emission found to be in a restricted band as defined by section 15.205, including any emission at the operational band-edge, was compared to the radiated emission limits as defined in Section 15.209.

For measurements below 30 MHz, the receive antenna height was set to 1m and the EUT was rotated through 360 degrees. The resolution bandwidth was set to 200 Hz below 150 kHz and to 9 kHz above 150 kHz.

The EUT was rotated through 360° and the receive antenna height was varied from 1m to 4m so that the maximum radiated emissions level would be detected. For frequencies below 1000MHz, quasi-peak measurements were made using a resolution bandwidth RBW of 120 kHz and a video bandwidth VBW of 300 kHz. For frequencies above 1000 MHz, peak measurements are made with RBW of 1 MHz and VBW of 3 MHz. Average measurements are performed in the linear scale using VBW of 30 Hz.

7.4.3.2 Measurement Results

Radiated band-edge and spurious emissions found in the restricted frequency bands of 9 kHz to 26 GHz are reported in the tables below.

Table 7.4.3.2-1: Radiated Spurious Emissions Tabulated Data

| Frequency (MHz) | Level (dBuV) | | Antenna Polarity (H/V) | Correction Factors (dB) | Corrected Level (dBuV/m) | | Limit (dBuV/m) | | Margin (dB) | |
|--------------------------------|--------------|---------|------------------------|-------------------------|--------------------------|---------|----------------|---------|-------------|---------|
| | pk | Qpk/Avg | | | pk | Qpk/Avg | pk | Qpk/Avg | pk | Qpk/Avg |
| Low Channel 2402 MHz | | | | | | | | | | |
| 2390 | 61.19 | 46.86 | V | -5.35 | 55.84 | 41.51 | 74.0 | 54.0 | 18.2 | 12.5 |
| Middle Channel 2440 MHz | | | | | | | | | | |
| 7320 | 43.58 | 32.24 | H | 9.46 | 53.04 | 41.70 | 74.0 | 54.0 | 21.0 | 12.3 |
| 7320 | 45.45 | 35.01 | V | 9.46 | 54.91 | 44.47 | 74.0 | 54.0 | 19.1 | 9.5 |
| High Channel 2480 MHz | | | | | | | | | | |
| 2483.5 | 61.53 | 44.88 | H | -4.89 | 56.64 | 39.99 | 74.0 | 54.0 | 17.4 | 14.0 |
| 2483.5 | 77.51 | 53.11 | V | -4.89 | 72.62 | 48.22 | 74.0 | 54.0 | 1.4 | 5.8 |
| 7440 | 42.82 | 31.15 | H | 9.80 | 52.62 | 40.95 | 74.0 | 54.0 | 21.4 | 13.1 |
| 7440 | 44.82 | 34.13 | V | 9.80 | 54.62 | 43.93 | 74.0 | 54.0 | 19.4 | 10.1 |

Note: All emissions above 7.44 GHz were attenuated below the limits and the noise floor of the measurement equipment.

7.4.3.3 Sample Calculation:

$$R_C = R_U + CF_T$$

Where:

| | | |
|--------|---|---|
| CF_T | = | Total Correction Factor (AF+CA+AG)-DC (Average Measurements Only) |
| R_U | = | Uncorrected Reading |
| R_C | = | Corrected Level |
| AF | = | Antenna Factor |
| CA | = | Cable Attenuation |
| AG | = | Amplifier Gain |
| DC | = | Duty Cycle Correction Factor |

Example Calculation: PeakCorrected Level: $61.19 + (-5.35) = 55.84 \text{ dB}\mu\text{V/m}$ Margin: $74 \text{ dB}\mu\text{V/m} - 55.84 \text{ dB}\mu\text{V/m} = 18.2 \text{ dB}$ **Example Calculation: Average**Corrected Level: $46.86 + (-5.35) = 41.51 \text{ dB}\mu\text{V/m}$ Margin: $54 \text{ dB}\mu\text{V/m} - 41.51 \text{ dB}\mu\text{V/m} = 12.5 \text{ dB}$

7.5 Power Spectral Density - FCC Section 15.247(e); ISED Canada: RSS-247 5.2(2)

7.5.1 PSD Measurement Procedure (Conducted Method)

The power spectral density was measured in accordance with the FCC KDB 558074 D01 DTS Meas Guidance v03r05 Section 10.2 Method PKPSD (peak PSD). The RF output port of the EUT was directly connected to the input of the spectrum analyzer. Offset values were input for cable and external attenuation. The spectrum analyzer RBW was set to 3 kHz and VBW 10 kHz. Span was adjusted to 1.5 times the 6 dB bandwidth and the sweep time was set to auto.

7.5.2 Measurement Results

Results are shown below.

Table 7.5.2-1: Power Spectral Density

| Frequency [MHz] | PSD [dBm] | Limit [dBm] | Margin [dB] |
|-----------------|-----------|-------------|-------------|
| 2402 | -14.45 | 8.0 | 22.45 |
| 2440 | -13.85 | 8.0 | 21.85 |
| 2480 | -13.77 | 8.0 | 21.77 |

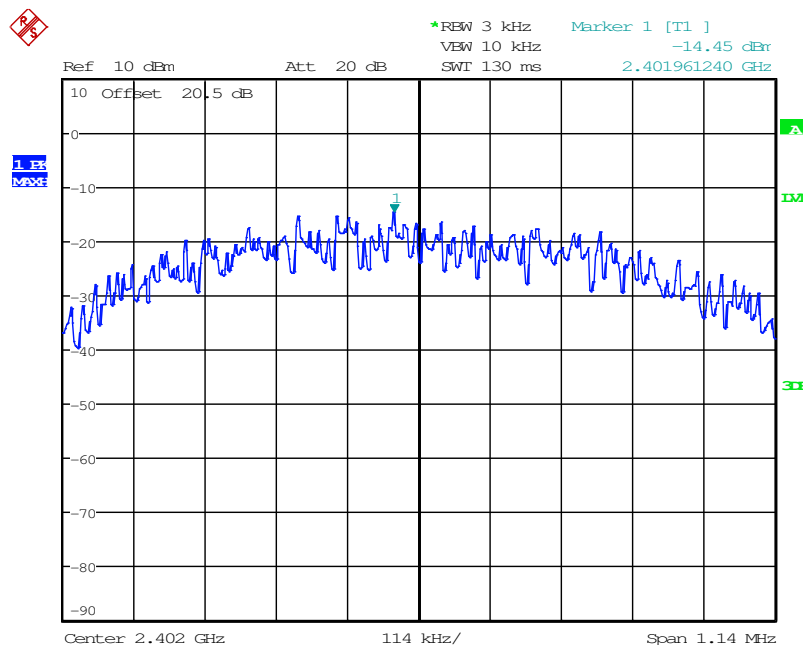

Date: 25.AUG.2016 14:23:10

Figure 7.5.2-1: Power Spectral Density - Low Channel

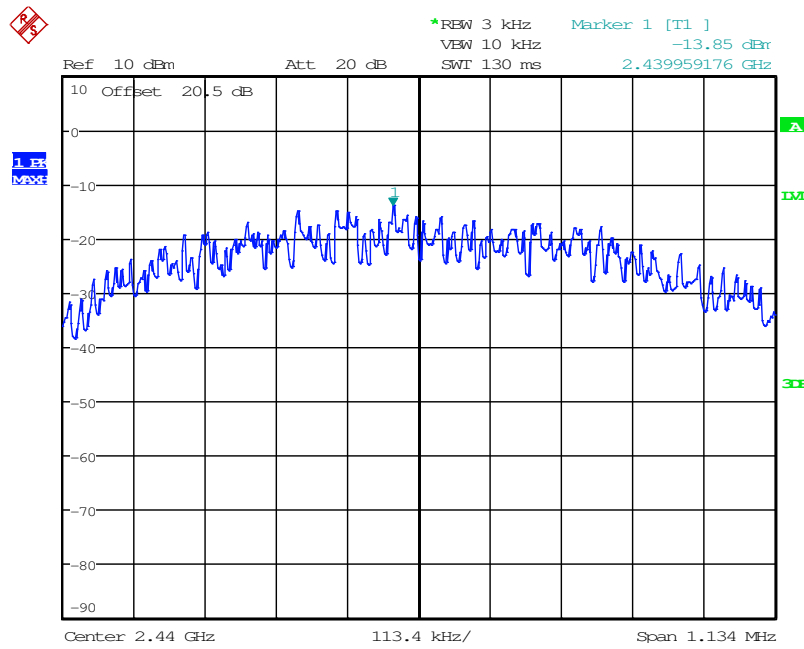

Date: 29.AUG.2016 16:24:53

Figure 7.5.2-2: Power Spectral Density - Middle Channel

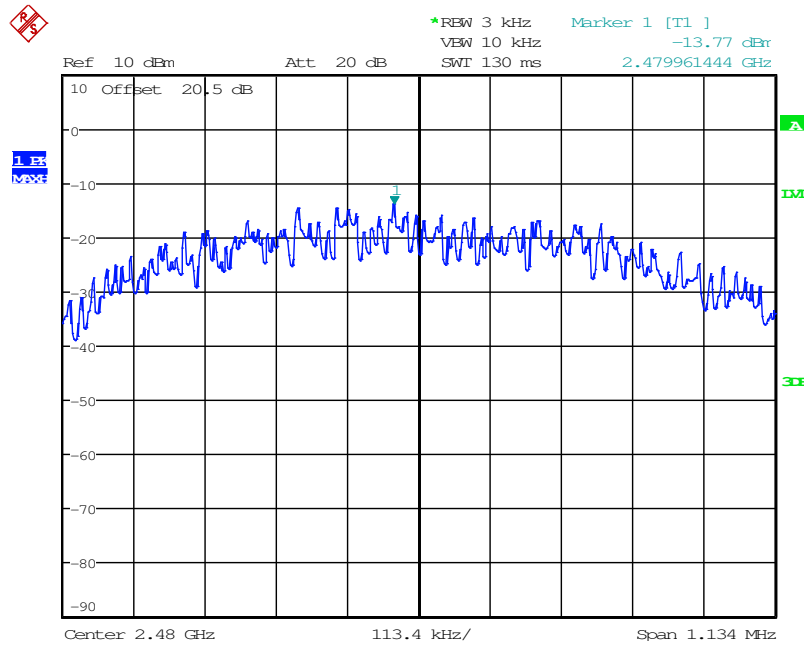

Date: 29.AUG.2016 16:30:22

Figure 7.5.2-3: Power Spectral Density – High Channel

7.6 Power Line Conducted Emissions – FCC: Section 15.207; ISED Canada: RSS-Gen 8.8

7.6.1 Measurement Procedure

ANSI C63.10 section 6.2 was the guiding document for this evaluation. Conducted emissions were performed from 150 kHz to 30 MHz with the spectrum analyzer’s resolution bandwidth set to 9 kHz and the video bandwidth set to 30 kHz. The calculation for the conducted emissions is as follows:

$$\text{Corrected Reading} = \text{Analyzer Reading} + \text{LISN Loss} + \text{Cable Loss}$$

$$\text{Margin} = \text{Applicable Limit} - \text{Corrected Reading}$$

7.6.2 Measurement Results

Results are shown below.

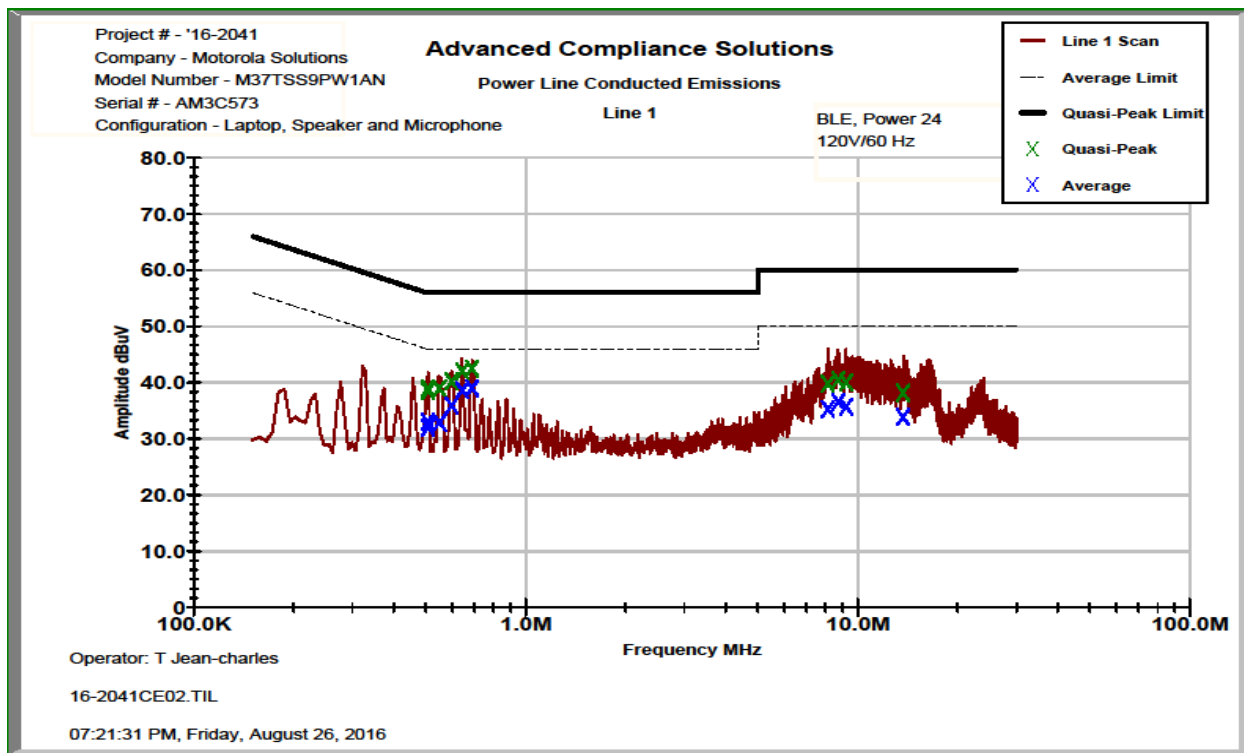

Figure 7.6.2-1: Conducted Emissions Results – Line 1

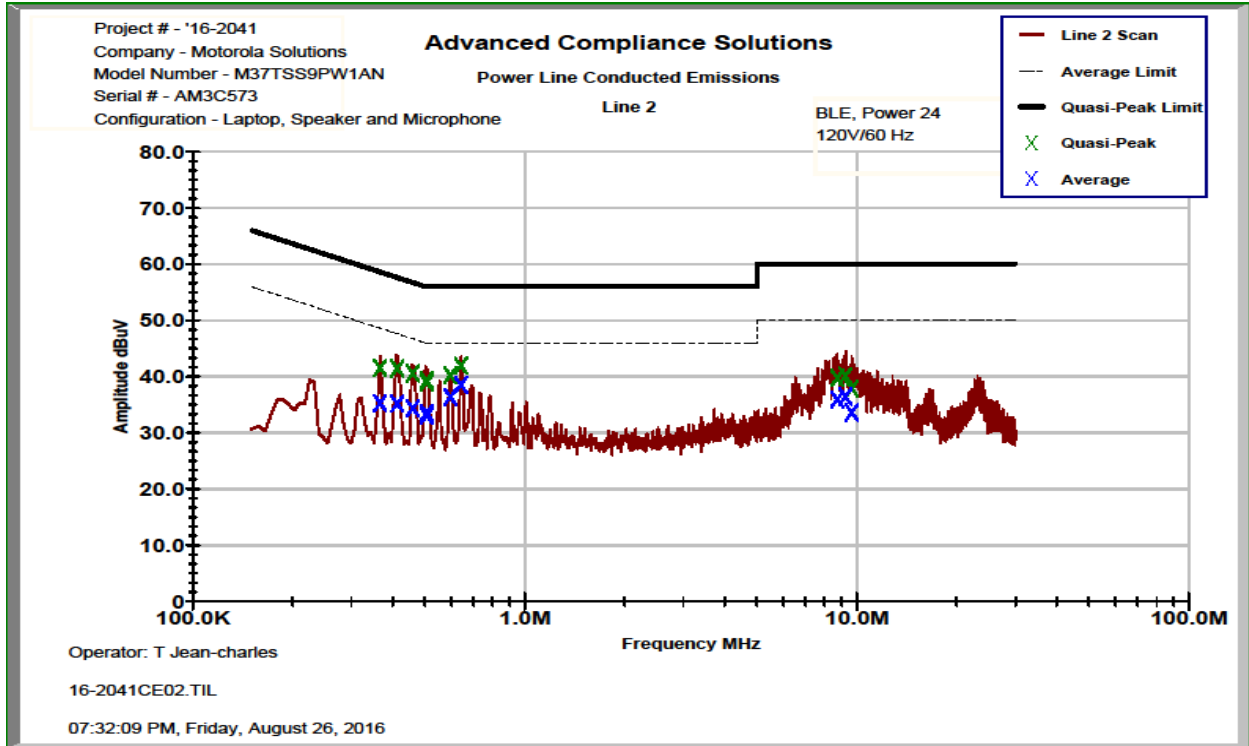

Figure 7.6.2-2: Conducted Emissions Results – Line 2

Table 7.6.2-1: Conducted EMI Results

Line 1 Line 2 Line 3
 Line 4
 To Ground Floating
 Telecom Port _____
 dB μ V dB μ A

 Plot Number: 16-2041CE02
 Power Supply Description: 15 VDC power supply

| Frequency (MHz) | Uncorrected Reading | | Total Correction Factor (dB) | Corrected Level | | Limit | | Margin (dB) | |
|-----------------|---------------------|---------|------------------------------|-----------------|---------|------------|---------|-------------|---------|
| | Quasi-Peak | Average | | Quasi-Peak | Average | Quasi-Peak | Average | Quasi-Peak | Average |
| Line 1 | | | | | | | | | |
| 0.50615 | 28.75 | 22.784 | 10.20 | 38.95 | 32.99 | 56.00 | 46.00 | 17.0 | 13.0 |
| 0.5071 | 28.292 | 21.775 | 10.20 | 38.50 | 31.98 | 56.00 | 46.00 | 17.5 | 14.0 |
| 0.548812 | 28.742 | 22.674 | 10.20 | 38.95 | 32.88 | 56.00 | 46.00 | 17.1 | 13.1 |
| 0.59745 | 30.007 | 25.665 | 10.20 | 40.21 | 35.87 | 56.00 | 46.00 | 15.8 | 10.1 |
| 0.642424 | 31.843 | 28.399 | 10.20 | 42.04 | 38.60 | 56.00 | 46.00 | 14.0 | 7.4 |
| 0.688 | 32.281 | 28.786 | 10.20 | 42.48 | 38.98 | 56.00 | 46.00 | 13.5 | 7.0 |
| 8.11995 | 29.162 | 24.688 | 10.59 | 39.75 | 35.28 | 60.00 | 50.00 | 20.2 | 14.7 |
| 8.7221 | 29.845 | 25.936 | 10.61 | 40.46 | 36.55 | 60.00 | 50.00 | 19.5 | 13.5 |
| 9.21061 | 29.383 | 25.029 | 10.63 | 40.01 | 35.66 | 60.00 | 50.00 | 20.0 | 14.3 |
| 13.6656 | 27.33 | 22.964 | 10.79 | 38.12 | 33.76 | 60.00 | 50.00 | 21.9 | 16.2 |
| Line 2 | | | | | | | | | |
| 0.366163 | 31.309 | 25.065 | 10.20 | 41.51 | 35.27 | 58.59 | 48.59 | 17.1 | 13.3 |
| 0.412787 | 31.209 | 24.937 | 10.21 | 41.42 | 35.15 | 57.59 | 47.59 | 16.2 | 12.4 |
| 0.459513 | 30.355 | 24.105 | 10.21 | 40.57 | 34.32 | 56.70 | 46.70 | 16.1 | 12.4 |
| 0.505038 | 29.121 | 23.322 | 10.21 | 39.33 | 33.53 | 56.00 | 46.00 | 16.7 | 12.5 |
| 0.50595 | 28.749 | 22.791 | 10.21 | 38.95 | 33.00 | 56.00 | 46.00 | 17.0 | 13.0 |
| 0.5965 | 30.021 | 26.155 | 10.21 | 40.23 | 36.37 | 56.00 | 46.00 | 15.8 | 9.6 |
| 0.641374 | 31.692 | 28.321 | 10.21 | 41.90 | 38.53 | 56.00 | 46.00 | 14.1 | 7.5 |
| 8.718 | 29.05 | 25.264 | 10.65 | 39.70 | 35.91 | 60.00 | 50.00 | 20.3 | 14.1 |
| 9.22867 | 29.415 | 25.727 | 10.67 | 40.08 | 36.39 | 60.00 | 50.00 | 19.9 | 13.6 |
| 9.64089 | 27.127 | 22.889 | 10.68 | 37.81 | 33.57 | 60.00 | 50.00 | 22.2 | 16.4 |

8 CONCLUSION

In the opinion of ACS, Inc., the model M37TSS9PW1AN manufactured by Motorola Solutions meets the requirements of FCC Part 15 subpart C and Innovation, Science and Economic Development Canada's Radio Standards Specification RSS-247 for the test procedures documented in the test report.

END REPORT