

## **EMC** EMISSION - **TEST REPORT**

JQA APPLICATION No. : KL80010003

Name of Product : 2.4GHz Frequency Hopping Spread Spectrum Cordless Telephone

Model/Type No. : KX-TGA420B

FCC ID : ACJ96NKX-TGA420

Applicant : Kyushu Matsushita Electric Co., Ltd.

Address : 1-62, 4-chome, Minoshima, Hakata-ku, Fukuoka 812-8531, Japan

Manufacturer : Kyushu Matsushita Electric Co., Ltd.

Address : 1-62, 4-chome, Minoshima, Hakata-ku, Fukuoka 812-8531, Japan

Receive date of EUT : April 2, 2001

**Final Judgement** : Passed

**TEST RESULTS IN THIS REPORT** are obtained in use of equipment that is traceable to Electro-technical Lab. of MITI Japan and Communications Research Lab. of PTT Japan.

**THE TEST RESULTS** only responds to the test sample. This test report shall not be reproduced except in full.

JAPAN QUALITY ASSURANCE ORGANIZATION (JQA)  
KITA-KANSAI TESTING CENTER  
EMC DIVISION

## **DIRECTORY**

	<b>Page</b>
<b>A) Documentation</b>	
Directory	<u>2</u>
Test Regulation / General Information	<u>3 - 5</u>
Test Conditions	<u>6 - 14</u>
Configuration of EUT / Operation mode of the EUT	<u>15 - 16</u>
EUT Modification / Responsible Party / Deviation from Standard	<u>17</u>
Test results / Measurement Uncertainty	<u>18 - 21</u>
Summary	<u>22</u>
<b>Test System-Arrangement (Drawings)</b>	<u>23</u>
<b>Preliminary Test and Test-setup (Drawings)</b>	<u>24 - 27</u>
<b>Test-setup (Photographs) at worst case</b>	<u>28</u>
<b>B) Test data</b>	
Conducted Emission	450 kHz - 30 MHz
	<u>29</u>
Electromagnetic Field Radiated Emission	9 kHz - 25 GHz
	<u>30 - 34</u>
Maximum Peak Power (EIRP)	<u>35</u>
Transmitter Power (TP)	<u>36</u>
Antenna Gain of the EUT	<u>37</u>
-20dB Bandwidth and Band-edge Emission	<u>38 - 43</u>
Carrir Frequencies Seperation	<u>44 -45</u>
Number of Hopping Frequencies	<u>46</u>
Dwell Time	<u>47 - 51</u>
Channel Seperation / Dwell Time	<u>52 - 53</u>

## TEST REGULATION

FCC Rules and Regulations Part 15 Subpart A and C (September 20, 2000)

- Class A Digital Device
- Class B Digital Device
- Intentional Radiator(Sec.15.247)
- Receiver

### **Test items:**

- Sec.15.203 : Antenna requirement
- Sec.15.205 : Restricted bands of operation
- Sec.15.207 : Conducted limits
- Sec.15.209 : Radiated emission limits general requirements
- Sec.15.214 : Cordless Telephones
- Sec.15.247 : Operation within the bands 902-928MHz, 2400-2483.5MHz, 5725-5875MHz, and 24.0-24.25GHz

### **Test procedure:**

Conducted emission and radiated emission test were performed according to the procedures in ANSI C63.4-1992.

## GENERAL INFORMATION

### **Test facility:**

- 1) Test Facility located at Kita-Kansai : 1st and 2nd Open Sites (3 m Site)  
Test Facility located at Kameoka Open Site (3, 10 and 30 m, on common plane)  
**FCC filing No. : 31040/SIT 1300F2**
- 2) KITA-KANSAI TESTING CENTER is recognized under the National Voluntary Laboratory Accreditation Program for satisfactory compliance established in Title 15, Part 285 Code of Federal Regulations.  
**NVLAP Lab Code: 200191-0**

### **Definitions for symbols used in this test report:**

- Black box indicates that the listed condition, standard or equipment is applicable for this Report.
- Blank box indicates that the listed condition, standard or equipment is not applicable for this Report.

**Description of the Equipment Under Test (EUT):**

- 1) Name : 2.4GHz Frequency Hopping Spread Spectrum Cordless Telephone
- 2) Model/Type No. : KX-TGA420B
- 3) Product Type : Pre-Production (S/N: ---)
- 4) Category : Intentional Radiator
- 5) EUT Authorization :  - Verification  - Certification  - D.o.C.
- 6) Transmitting Frequency : 2401.056 MHz(00ch) - 2479.680 MHz(91ch)
- 7) Receiving Frequency : 2401.056 MHz(00ch) - 2479.680 MHz(91ch)
- 8) Method/System : Frequency Hopping Spread System(FHSS)
- 9) Type of Antenna : Omni-directional Antenna
- 10) Antenna Gain : 2.15 dBi
- 11) Typical TX Power : 281.3 mW(24.5 dBm)
- 12) Power Rating : AC 120V 60Hz 1 $\phi$  2-pin plug(AC adaptor : PQLV1)

**Detailed Transmitter portion(Channel plan):**

Transmitting frequency : 2401.056MHz(00ch) - 2479.680 MHz(91ch)  
Number of channel : 92  
Channel Separation : 864 kHz

CH	0	1	2	3	4	5	6	7	8	9
0	2401.056	2401.920	2402.784	2403.648	2404.512	2405.376	2406.240	2407.104	2407.968	2408.832
10	2409.696	2410.560	2411.424	2412.288	2413.152	2414.016	2414.880	2415.744	2416.608	2417.472
20	2418.336	2419.200	2420.064	2420.928	2421.792	2422.656	2423.520	2424.384	2425.248	2426.112
30	2426.976	2427.840	2428.704	2429.568	2430.432	2431.296	2432.160	2433.024	2433.888	2434.752
40	2435.616	2436.480	2437.344	2438.208	2439.072	2439.936	2440.800	2441.664	2442.528	2443.392
50	2444.256	2445.120	2445.984	2446.848	2447.712	2448.576	2449.440	2450.304	2451.168	2452.032
60	2452.896	2453.760	2454.624	2455.488	2456.352	2457.216	2458.080	2458.944	2459.808	2460.672
70	2461.536	2462.400	2463.264	2464.128	2464.992	2465.856	2466.720	2467.584	2468.448	2469.312
80	2470.176	2471.040	2471.904	2472.768	2473.632	2474.496	2475.360	2476.224	2477.088	2477.952
90	2478.816	2479.680								

**Modulation System Information:**

Spread Spectrum Method : Frequency Hopping  
Modulation : GFSK(Gaussian-shaped Binary Frequency Shift Keying)  
Gaussian Filter Bt = 0.5  
Bit Rate = 576 Kbps  
Digital Security Code : 32bits

**Detailed Receiver portion:**

Receiving frequency : 2401.056MHz(00ch) - 2479.680 MHz(91ch)  
Local frequency : 2290.464MHz(00ch) - 2369.088 MHz(91ch)  
Intermediate frequency : 110.592 MHz

**The used (generated) frequencies in the EUT:**

Reference Clock : 10.368 MHz

## TEST CONDITIONS

**AC Powerline Conducted Emission Measurement(Sec.15.207(a))**  
was performed in the following test site.

### **Test location:**

KITA-KANSAI Testing Center

7-7, Ishimaru, 1-Chome, Mino-Shi, Osaka, 562-0027, Japan

● - Shielded room

KAMEOKA EMC Branch

9-1, Ozaki, Inukanno, Nishibetsuin-Cho, Kameoka-Shi, Kyoto, 621-0126, Japan

○ - Shielded room

○ - On metal plane of open site

### **Used test instruments and sites:**

Model No.	Device ID	Last Cal. Date	Cal. Interval
○ - ESCS 30	A - 1		
● - ESH 2	A - 2	May, 2000	1 Year
○ - ESH 2	A - 3		
● - KNW-407	D - 6	January, 2001	1 Year
○ - KNW-408	D - 11		
○ - KNW-242	D - 7		
○ - ESH3-Z5	D - 12		
○ - KNW-341C	D - 13		
○ - KNW-408	D - 14		
○ - KNW-244C	D - 77		
○ - KNW-408	D - 78		
○ - ESH2-Z5	D - 10		
○ - ESH2-Z3	D - 17		
○ - 65 BNC-50-0-1	H - 26		
○ - 65 BNC-50-0-1	H - 27		
○ - Cable	H - 7		
● - Cable	H - 8	January, 2001	1 Year

### **Environmental conditions:**

Temperature: 24 °C      Humidity: 48 %

**Magnetic Field Radiated Emission Measurement(Sec.15.247(c),15.205(a),15.209(a))**

was performed in the frequency range of 9 kHz - 30 MHz, in the following test site.

**Test location:**

KITA-KANSAI Testing Center

7-7, Ishimaru, 1-Chome, Mino-Shi, Osaka, 562-0027, Japan

● - 1st open test site (3 meters)

○ - 2nd open test site (3 meters)

KAMEOKA EMC Branch

9-1, Ozaki, Inukanno, Nishibetsuin-Cho, Kameoka-Shi, Kyoto, 621-0126, Japan

○ - 1st open test site                      ○ - 3 m                      ○ - 10 m                      ○ - 30 m

○ - 2nd open test site                      ○ - 3 m                      ○ - 10 m

**Used test instruments:**

Model No.	Device ID	Last Cal. Date	Cal. Interval
○ - ESCS 30	A - 1		
● - ESH 2	A - 2	May, 2000	1 Year
○ - ESH 2	A - 3		
○ - HFH2-Z2	C - 2		
● - HFH2-Z2	C - 3	July, 2000	1 Year

**Environmental conditions:**

Temperature: 27 °C      Humidity: 34 %

**Electromagnetic Field Radiated Emission Measurement(Sec.15.247(c),15.205(a),15.209(a))**

was performed in horizontal and vertical polarization, in the frequency range of 30 MHz - 1000 MHz, in the following test site.

**Test location:**

KITA-KANSAI Testing Center

7-7, Ishimaru, 1-Chome, Mino-Shi, Osaka, 562-0027, Japan

- - 1st open test site (3 meters)
- - 2nd open test site (3 meters)

KAMEOKA EMC Branch

9-1, Ozaki, Inukanno, Nishibetsuin-Cho, Kameoka-Shi, Kyoto, 621-0126, Japan

- - 1st open test site                      ○ - 3 m            ○ - 10 m            ○ - 30 m
- - 2nd open test site                      ○ - 3 m            ○ - 10 m

**Validation of Site Attenuation:**

- 1) Last Confirmed Date : October 24, 2000
- 2) Interval : 1 Year

**Used test instruments:**

Model No.	Device ID	Last Cal. Date	Cal. Interval
● - ESV/ESV-Z3	A - 7 / A - 17	December, 2000	1 Year
○ - ESV/ESV-Z3	A - 6 / A - 18		
○ - ESV/ESV-Z3	A - 4 / A - 20		
○ - ESV/ESV-Z3	A - 8 / A - 19		
○ - ESVS 10	A - 5		
● - KBA-511A	C - 12	November, 2000	1 Year
● - KBA-611	C - 22	November, 2000	1 Year
○ - KBA-511A	C - 13	November, 2000	1 Year
○ - KBA-611	C - 19		
○ - KBA-511A	C - 11		
○ - KBA-611	C - 21		
○ - Cable	H - 1		
○ - Cable	H - 2		
● - Cable	H - 5		
○ - Cable	H - 6		
○ - Cable	H - 9		

**Environmental conditions:**

Temperature: 27 °C      Humidity: 34 %

**Electromagnetic Field Radiated Emission Measurement(Sec.15.247(c),15.205(a),15.209(a))  
Maximum Peak Power (EIRP) Measurement(Sec.15.247(b)(1))**

was performed in horizontal and vertical polarization, in the frequency range of 1 GHz - 25 GHz,  
in the following test site.

**Test location:**

KITA-KANSAI Testing Center

7-7, Ishimaru, 1-Chome, Mino-Shi, Osaka, 562-0027, Japan

● - 1st open test site (3 meters)

○ - 2nd open test site (3 meters)

KAMEOKA EMC Branch

9-1, Ozaki, Inukanno, Nishibetsuin-Cho, Kameoka-Shi, Kyoto, 621-0126, Japan

○ - 1st open test site                      ○ - 3 m              ○ - 10 m              ○ - 30 m

○ - 2nd open test site                      ○ - 3 m              ○ - 10 m

**Used test instruments:**

Model No.	Device ID	Last Cal. Date	Cal. Interval
● - ESCS 30	A - 1	August, 2000	1 Year
● - 8566B	A - 13	December, 2000	1 Year
○ - 8593A	A - 15		
○ - ESV	A - 6		
● - 4T-10	D - 73	May, 2000	1 Year
● - 4T-10	D - 74	May, 2000	1 Year
● - WJ-6611-513	A - 23	May, 2000	1 Year
● - WJ-6882-824	A - 21	May, 2000	1 Year
● - DBL-0618N515	A - 33	May, 2000	1 Year
● - 91888-2	C - 41 - 1	May, 2000	1 Year
● - 91889-2	C - 41 - 2	May, 2000	1 Year
○ - 94613-1	C - 41 - 3		
○ - 91891-2	C - 41 - 4		
○ - 94614-1	C - 41 - 5		
● - 3160-04	C - 55	May, 2000	1 Year
● - 3160-05	C - 56	May, 2000	1 Year
● - 3160-06	C - 57	May, 2000	1 Year
● - 3160-07	C - 58	May, 2000	1 Year
● - 3160-08	C - 59	May, 2000	1 Year
● - 3160-09	C - 48	May, 2000	1 Year
● - 355C	D - 22	March, 2001	1 Year
● - 355D	D - 23	March, 2001	1 Year
○ - 8494H/8595H	D - 76		
● - MZ5010C	D - 81	October, 2000	1 Year
● - 8673D	B - 2	April, 2000	1 Year
● - Cable	C - 40 - 11	May, 2000	1 Year
● - Cable	C - 40 - 12	May, 2000	1 Year

**Environmental conditions:**

Temperature: 22 °C      Humidity: 48 %

### Transmitter Power(TP) Measurement (Sec.15.247(b)(1))

#### Test Procedure :

The Transmitter Power was measured with a spectrum analyzer, one 10 dB attenuators and a short, low loss cable.

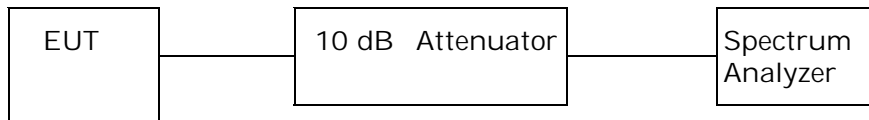

#### Test location :

KITA-KANSAI Testing Center  
7-7, Ishimaru, 1-Chome, Mino-Shi, Osaka, 562-0027, Japan

● - Shielded room

KAMEOKA EMC Branch

9-1, Ozaki, Inukanno, Nishibetsuin-Cho, Kameoka-Shi, Kyoto, 621-0126, Japan

○ - Shielded room

#### Used test instruments and sites :

Model No.	Device ID	Last Cal. Date	Cal. Interval
● - 8566B	A - 13	December, 2000	1 Year
○ - 432B/8478B	B - 24/B-43		
○ - 6-20	D - 27	May, 2001	1 Year
● - 4T-10	D - 73		
○ - 4T-10	D - 74		
○ - 8566B	A - 13		
○ - 8593A	A - 15		

#### Environmental conditions :

Temperature: 22 °C      Humidity: 48 %

**-20dB Bandwidth Measurement(Sec.15.247(a)(1)(ii))**

**Test Procedure :**

The measurement test-up is shown in the figure. The modulation is set to page 16.

The setting of the spectrum analyzer are shown as follows :

Res. Bandwidth : 10 kHz  
Video Bandwidth : 30 kHz  
Span : 2 MHz  
Sweep Time : AUTO  
Trace : Maxhold

**Used test instruments:**

Model No.	Device ID	Last Cal. Date	Cal. Interval
● - 8566B	A - 13	December, 2000	1 Year
○ - 4T-10	D - 73		
○ - 91888-2	C - 41 - 1		
● - 91889-2	C - 41 - 2	May, 2000	1 Year

**Band-edge Emission Measurement(§15.247(c))**

**Test Procedure :**

The measurement test-up is shown in the figure. The modulation is set to page 16.

The setting of the spectrum analyzer are shown as follows :

Center Frequency : 2400 MHz / 2483.5 MHz  
Res. Bandwidth : 100 kHz  
Video Bandwidth : 300 kHz  
Span : 2 MHz  
Sweep Time : AUTO  
Trace : Maxhold

**Used test instruments:**

Model No.	Device ID	Last Cal. Date	Cal. Interval
● - 8566B	A - 13	December, 2000	1 Year
○ - 4T-10	D - 73		
○ - 91888-2	C - 41 - 1		
● - 91889-2	C - 41 - 2	May, 2000	1 Year

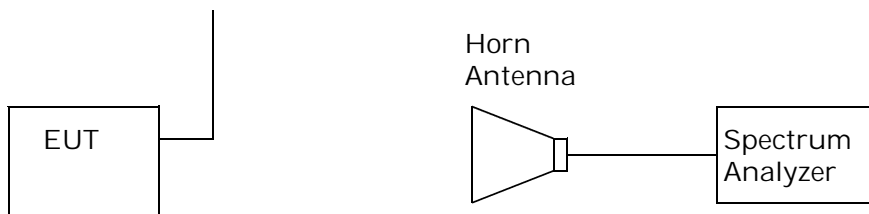

**Environmental conditions:**

Temperature: 22 °C Humidity: 48 %

**Carrier Frequency Separation Measurement(Sec.15.247(a)(1))**

**Test Procedure :**

The measurement test-up is shown in the figure. The modulation is set to page 15.

The transmitting frequency is set to 2439.936MHz(ch45) or 2440.800MHz(ch46).

The setting of the spectrum analyzer are shown as follows :

Center Frequency : 2440.3 MHz  
Res. Bandwidth : 100 kHz  
Video Bandwidth : 300 kHz  
Span : 10 MHz  
Sweep Time : AUTO  
Trace : Maxhold

**Used test instruments:**

Model No.	Device ID	Last Cal. Date	Cal. Interval
● - 8566B	A - 13	December, 2000	1 Year
○ - 4T-10	D - 73		
● - 91889-2	C - 41 - 2	May, 2000	1 Year

**Number of Hopping Frequencies Measurement(Sec.15.247(a)(ii))**

**Test Procedure :**

The measurement test-up is shown in the figure.  
The number of the hopping frequencies per 1 sec is measured.

**Used test instruments:**

Model No.	Device ID	Last Cal. Date	Cal. Interval
● - R3563	70260071	August, 2000	1 Year
○ - 4T-10	D - 73		
● - 91889-2	C - 41 - 2	May, 2000	1 Year
● - S321- 4000	--	--	--

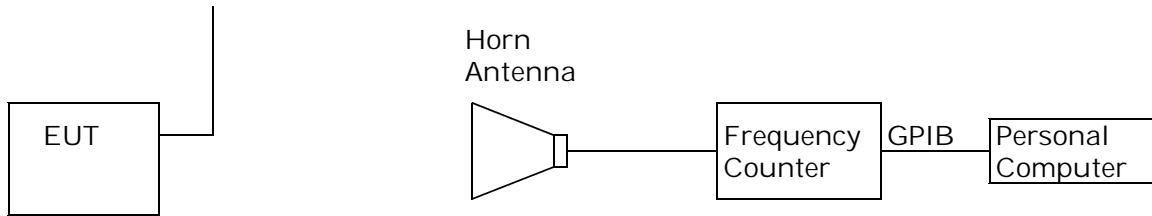

**Environmental conditions:**

Temperature: 22 °C      Humidity: 48 %

**Time of Occupancy(Dwell time) Measurement(Sec.15.247(a)(1)(iii))**

**Test Procedure :**

The measurement test-up is shown in the figure. The EUT is communicating with the base unit(Frequency Hopping Operation).

1) Pulse width of one slot(as 8 utilized) Measurement

The setting of the spectrum analyzer are shown as follows :

- Res. Bandwidth : 1 MHz
- Video Bandwidth : 1 MHz
- Span : 0 Hz
- Sweep Time : 20 msec
- Trace : Maxhold
- Trigger : Single

2) Dwell time measurement of occupancy in a 30 second period.

The setting of the spectrum analyzer are shown as follows :

- Res. Bandwidth : 100 kHz
- Video Bandwidth : 1 MHz
- Span : 0 Hz
- Sweep Time : 500 msec
- Trace : Maxhold(Maxholding Time = 30 sec)
- Trigger : Single

**Used test instruments:**

Model No.	Device ID	Last Cal. Date	Cal. Interval
● - 8566B	A - 13	December, 2000	1 Year
○ - 4T-10	D - 73		
○ - 91888-2	C - 41 - 1		
● - 91889-2	C - 41 - 2	May, 2000	1 Year
● - S321- 4000	--	--	--

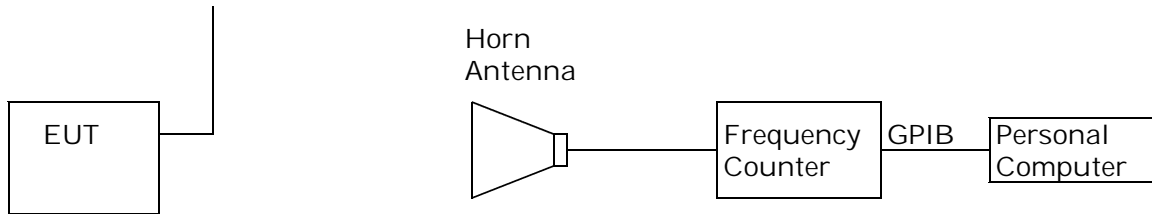

**Environmental conditions:**

Temperature: 22 °C      Humidity: 48 %

**CONFIGURATION OF EUT**

**The Equipment Under Test (EUT) consists of:**

Description	Applicant (Manufacturer)	Model No. (Serial No.)	FCC ID
2400MHz Frequency Hopping Spread Spectrum Cordless Telephone	Kyushu Matsushita Electric Co., Ltd. (Kyushu Matsushita Electric Co., Ltd.)	KX-TGA420B (--)	ACJ96NKX-TGA420
AC Adaptor	Kyushu Matsushita Electric Co., Ltd. (Kyushu Matsushita Electric Co., Ltd.)	PQLV1 (--)	N/A

**The measurement was carried out with the following equipment connected:**

Description	Grantee/Distributor	Model No. (Serial No.)	FCC ID
Headphone/Mic Set	Kyushu Matsushita Electric Co., Ltd.	KX-TCA88 (--)	N/A

**Type of Interference Cable(s) and the AC Power Cord used with the EUT:**

	Description	Port	Shielded Cable	Shell Material	Ferrite Core	Cable Length
1	EUT (DC power cord)	DC IN	NO	--	NO	1.9 m
	-----	AC Adaptor 1φ-2Pin Plug		--		
2	EUT	Handset	NO	--	NO	1.5 m
	-----	Headphone/Mic Set		--		

### **Operation - mode of the EUT:**

The EUT was operated during the test under the following specification:

Transmitting

Modulation signal : TDMA/TDD Burst Type(FSK 190kHz dev.)

For operating condition of the EUT, the typical modulating signal is not used and inputted because the occupied bandwidth of the EUT is subject to restriction due to the bit rate of preamble data other than audio data in the transmitting data .

### **Test system:**

The EUT has two ports, one DC IN port and one Handset port.

### **Special accessories:**

None



## TEST RESULTS

### AC Powerline Conducted Emission 450 kHz - 30 MHz(Sec.15.207(a))

The requirements are	<b>● - Passed</b>	<b>○ - Not Passed</b>
Min. limit margin	<u>+17.6</u> dB	at <u>7.40</u> MHz
Max. limit exceeding	_____ dB	at _____ MHz
Uncertainty of measurement results	<u>+ 2.1</u> dB(2 $\sigma$ )	<u>- 2.1</u> dB(2 $\sigma$ )

**Remarks:** \_\_\_\_\_  
\_\_\_\_\_

### Electromagnetic Field Radiated Emission 9 kHz - 25 GHz

#### Maximum Peak Power (EIRP)(Sec.15.247(b)(1))

The requirements are	<b>● - Passed</b>	<b>○ - Not Passed</b>
Maximum Peak Power (EIRP)	<u>0.533</u> W	at <u>2440.800</u> MHz
Min. limit margin	<u>2.7</u> dB	at <u>2440.800</u> MHz
Max. limit exceeding	_____ dB	at _____ MHz

#### Spurious(Sec.15.247(c),15.205(a),15.209(a))

The requirements are	<b>● - Passed</b>	<b>○ - Not Passed</b>
Min. limit margin	More than <u>7.2</u> dB	at <u>19526.40</u> MHz
Max. limit exceeding	_____ dB	at _____ MHz
Uncertainty of measurement results ( $\leq 30$ MHz)	<u>+ 2.5</u> dB(2 $\sigma$ )	<u>- 2.5</u> dB(2 $\sigma$ )
Uncertainty of measurement results (30 MHz - 1000 MHz)	<u>+ 4.1</u> dB(2 $\sigma$ )	<u>- 4.2</u> dB(2 $\sigma$ )
Uncertainty of measurement results ( $\geq 1000$ MHz)	<u>+ 3.1</u> dB(2 $\sigma$ )	<u>- 3.2</u> dB(2 $\sigma$ )

**Remarks:** \_\_\_\_\_  
\_\_\_\_\_

**Transmitter Power(TP)(Sec.15.247(b)(1))**

The requirements are	<b>● - Passed</b>	<b>○ - Not Passed</b>
The transmitter power is	<u>0.219</u> W at <u>2440.800</u> MHz	
Min. limit margin	<u>5.6</u> dB at <u>2440.800</u> MHz	
Max. limit exceeding	<u>        </u> dB at <u>        </u> MHz	
Uncertainty of measurement results	<u>+0.6</u> dB(2σ)	<u>-0.6</u> dB(2σ)

**Remarks:** \_\_\_\_\_  
\_\_\_\_\_

**Antenna Gain of the EUT(Sec.15.247(b)(3)(i))**

The antenna gain is 4.07 dBi at 2440.800 MHz

**Remarks:** \_\_\_\_\_  
\_\_\_\_\_

**-20dB Bandwidth(Sec.15.247(a)(1)(ii))**

The requirements are	<b>● - Passed</b>	<b>○ - Not Passed</b>
The -20dB Bandwidth is	<u>620.0</u> kHz at <u>2401.056</u> MHz	
The results	Refer to pages	39 - 41
Min. limit margin	<u>380.0</u> kHz at <u>2401.056</u> MHz	
Max. limit exceeding	<u>        </u> kHz at <u>        </u> MHz	
Uncertainty of measurement results at Frequency	<u>±0.05</u> ppm(2σ)	
Uncertainty of measurement results at Amplitude	<u>±0.6</u> dB(2σ)	

**Remarks:** \_\_\_\_\_  
\_\_\_\_\_

**Band-edge Emission(Sec.15.247(c))**

The requirements are

● - **Passed**      ○ - **Not Passed**

The results

Refer to pages 42 - 43

Uncertainty of measurement results at Frequency

±0.05 ppm(2σ)

Uncertainty of measurement results at Amplitude

±0.6 dB(2σ)

**Remarks:** \_\_\_\_\_  
\_\_\_\_\_

**Carrier Frequency Separation(Sec.15.247(a)(1))**

The requirements are

● - **Passed**      ○ - **Not Passed**

Channel Separation

860 kHz

The results

Refer to page 45

Uncertainty of measurement results at Frequency

±0.05 ppm(2σ)

Uncertainty of measurement results at Amplitude

±0.6 dB(2σ)

**Remarks:** \_\_\_\_\_  
\_\_\_\_\_

**Number of Hopping Frequencies(Sec.15.247(a)(ii))**

The requirements are

● - **Passed**      ○ - **Not Passed**

Number of Hopping Channel

100 hops/sec

**Remarks:** \_\_\_\_\_  
\_\_\_\_\_

**Time of Occupancy(Dwell time)(Sec.15.247(a)(1)(iii))**

The requirements are

● - **Passed**

○ - **Not Passed**

The average time of occupancy is less than 0.4 seconds within a 30 second.

The results

Refer to pages 50 - 53

Uncertainty of measurement results at Frequency

±0.05 ppm(2σ)

Uncertainty of measurement results at Amplitude

±0.6 dB(2σ)

**Remarks:** \_\_\_\_\_  
\_\_\_\_\_

**SUMMARY**

**GENERAL REMARKS :**

The EUT was tested according to the requirements of FCC Rules and Regulations Part 15 Subpart A and C (September 20, 2000) under the test configuration, as shown in page 21.

The conclusion for the test items of which are required by the applied regulation is indicated under the final judgement.

**FINAL JUDGEMENT :**

The "as received" sample;

- - fulfill the test requirements of the regulation mentioned on page 3.
- - fulfill the test requirements of the regulation mentioned on page 3, but with certain qualifications.
- - doesn't fulfill the test regulation mentioned on page 3.

Begin of testing : April 3, 2001

End of testing : April 19, 2001

- JAPAN QUALITY ASSURANCE ORGANIZATION -

Approved by :

Issued by :



\_\_\_\_\_  
Akio Hosoda  
Manager  
EMC Div.  
JQA KITA-KANSAI Testing Center

\_\_\_\_\_  
Shigeru Kinoshita  
Deputy Manager  
EMC Div.  
JQA KITA-KANSAI Testing Center

**Test System-Arrangement (Drawings)**

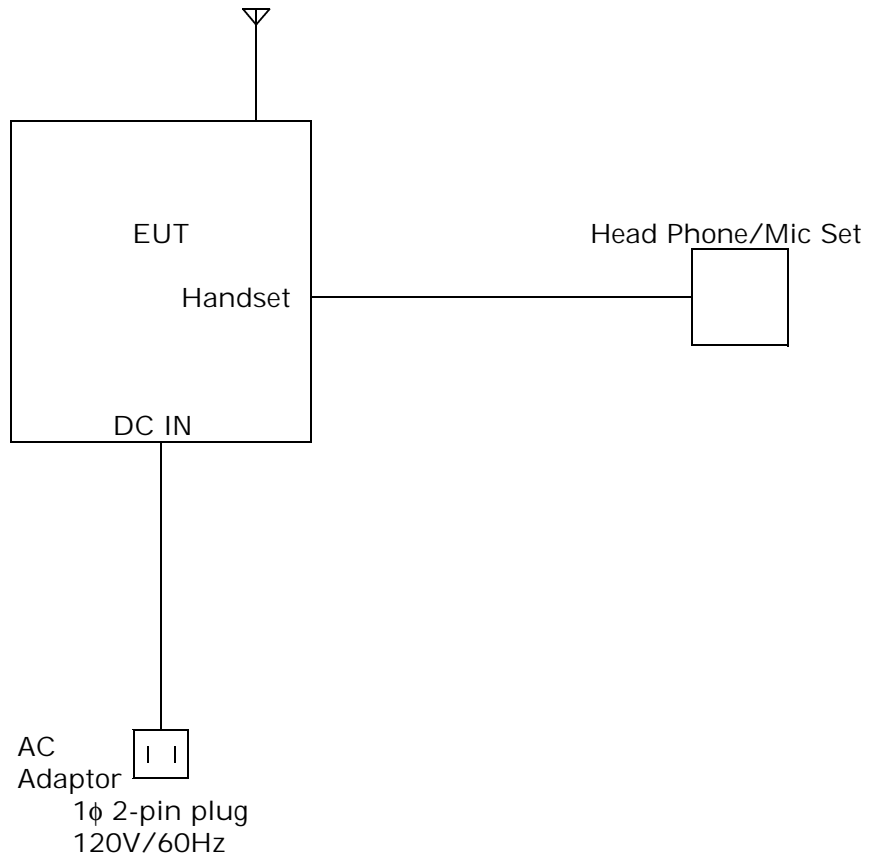

### **Preliminary Test and Test-setup(Drawings)**

#### AC Powerline Conducted Emission 450 kHz - 30 MHz:

The preliminary test was performed according to the description of ANSI C63.4-1992 Sec.7.2.3 (Preliminary AC Powerline Conducted Emissions Tests) and Sec.6.2.1 (Tabletop Equipment Tests).

The preliminary test was carried out to investigate the frequency of the emission that has the highest amplitude relative to the limits within normal operating modes, cable positions, and a typical system configuration. In order to find out to the maximum emission, the preliminary test and a final test were performed in accordance with the following steps.

Step 1: One operation mode of the test system was setting.

Step 2: Using both of a spectrum analyzer and a test receiver, the emission's circumstance from the system was monitored in one of ten divided frequency bands of the specified frequency range (450 kHz - 30 MHz). The maximum emission in the band was found by changing the typical cable positions or cable manipulation under a typical system configuration and by selecting of current-carrying conductor. The level and the frequency at the one point which are regarded as relative high emission in the band was measured and recorded. This step was repeated until the ending frequency band.

Step 3: Return to step 1, if the other operation mode was possible to be setting.

Step 4: Based on the collected results, the operation mode produced the maximum emission was selected. The final test on the selected operation mode was performed. But if it was difficult to select the operation mode, the final tests on all operation modes were performed.

Step 5: Based on the same data, as result if the final measurement, at the worst point that has the highest amplitude relative to the limit the repeatability of the worst was reconfirmed.

The photographs of the test system setup on the worst point were taken and recorded.

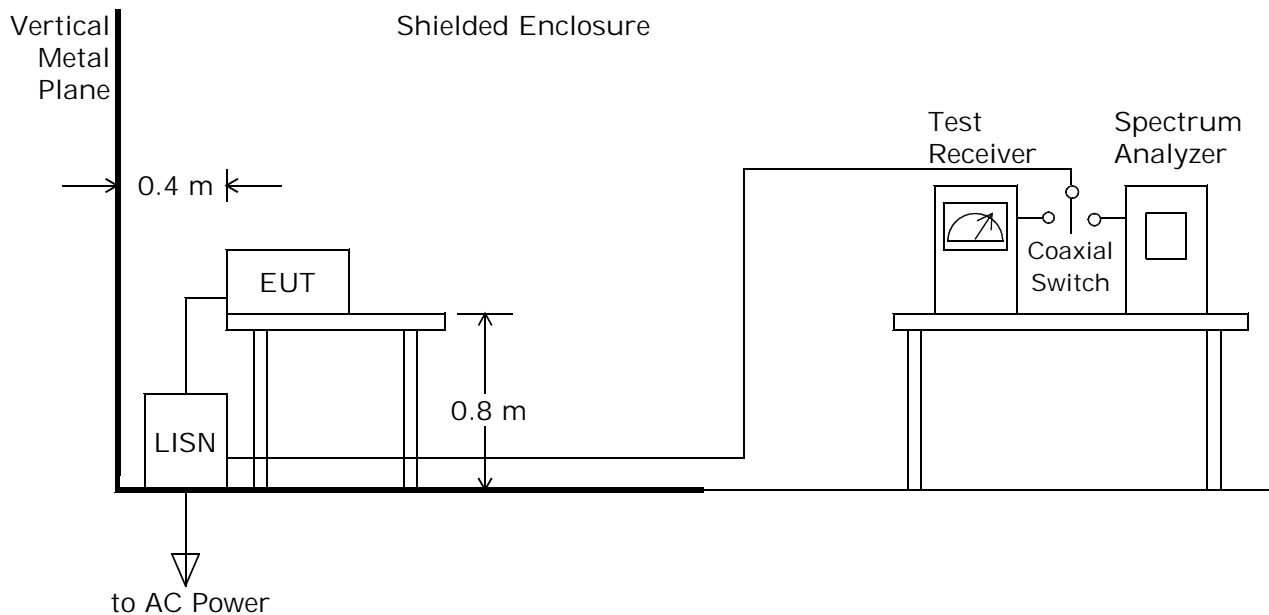

Radiated Emission (Magnetic Field) 9 kHz - 30 MHz:

The preliminary test was performed according to the description of ANSI C63.4-1992 Sec.8.3.1.1 (Preliminary Radiated Emissions Tests) and Sec.6.2.1 (Tabletop Equipment Tests).

The preliminary test was carried out to investigate the frequency of the emission that has the highest amplitude relative to the limits within normal operating modes, cable positions, and a typical system configuration. In order to find out to the maximum emission, the preliminary test and a final test were performed in accordance with the following steps.

Step 1: One operation mode of the test system was setting.

Step 2: In order to investigate the frequencies of maximum emissions, the loop antenna position was approached to the EUT and the significant frequency of the emission's circumstance from the test system were investigated. These data were recorded in the specified frequency band (9 kHz - 30 MHz).

Step 3: Using a test receiver and a loop antenna, the emission's circumstance from the test system was measured in according with ANSI C63.4-1992 Sec.8.3.1.2 (Final Radiated Emissions Tests) at each frequency which was found the higher emission referred to level vs. frequency on the list and which was measured by the loop antenna. The maximum emission was found by changing the cable positions, the antenna position or cable manipulation under a typical system configuration.

Step 4: Return to step 1, if the other operation mode was possible to be setting.

Step 5: The worst result was reported arranging data of which was obtained and performed by one or plural operation modes as the final test.

At the worst point that has the highest amplitude relative to the limit the repeatability of the level was reconfirmed. The photographs of the tests system setup on the worst point were taken and recorded.

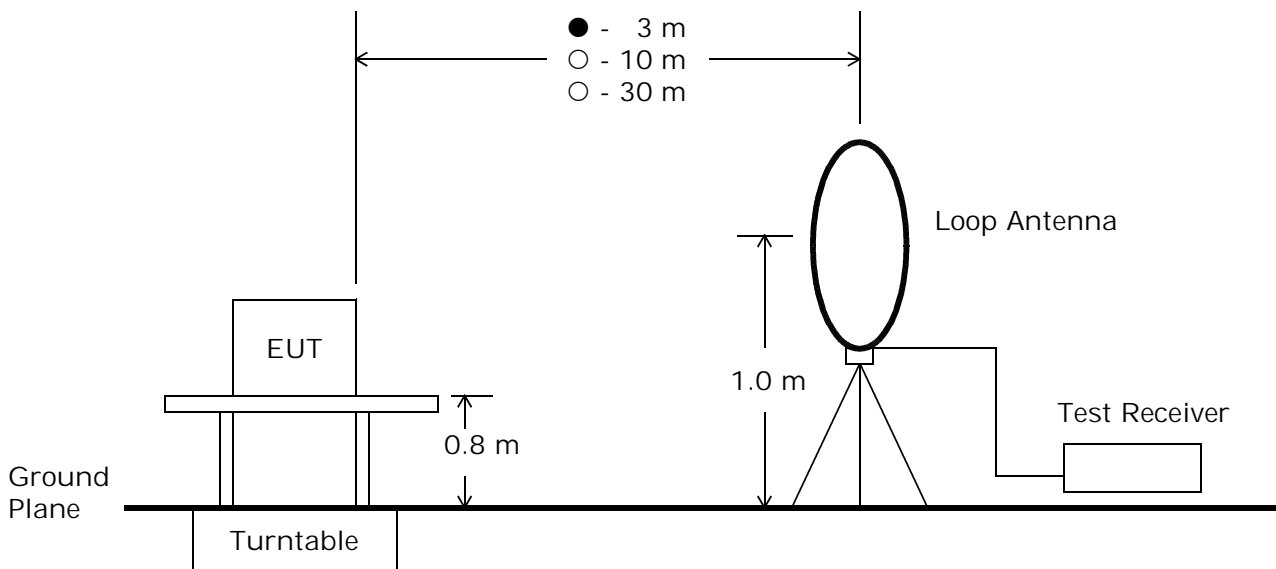

Electromagnetic Field Radiated Emission 30 MHz - 1000 MHz:

The preliminary test was performed according to the description of ANSI C63.4-1992 Sec.8.3.1.1 (Preliminary Radiated Emissions Tests) and Sec.6.2.1 (Tabletop Equipment Tests).

The preliminary test was carried out to investigate the frequency of the emission that has the highest amplitude relative to the limits within normal operating modes, cable positions, and a typical system configuration. In order to find out to the maximum emission, the preliminary test and a final test were performed in accordance with the following steps.

Step 1: One operation mode of the test system was setting.

Step 2: Using a test receiver and a test antenna probe, the significant frequency of the emission's circumstance from the test system were investigated. These data were recorded every one of 22 divided bands in the specified frequency band (30 MHz - 1000 MHz).

Step 3: Using a test receiver and a resonant tuned dipole antenna, the emission's circumstance from the test system was measured in according with ANSI C63.4-1992 Sec.8.3.1.2 (Final Radiated Emissions Tests) at each frequency which was found the higher emission referred to level vs. frequency on the list and which was measured by the resonant tuned dipole antenna. The maximum emission was found by changing the cable positions, the antenna position or cable manipulation under a typical system configuration.

Step 4: Return to step 1, if the other operation mode was possible to be setting.

Step 5: The worst result was reported arranging data of which was obtained and performed by one or plural operation modes as the final test.

At the worst point that has the highest amplitude relative to the limit the repeatability of the level was reconfirmed. The photographs of the tests system setup on the worst point were taken and recorded.

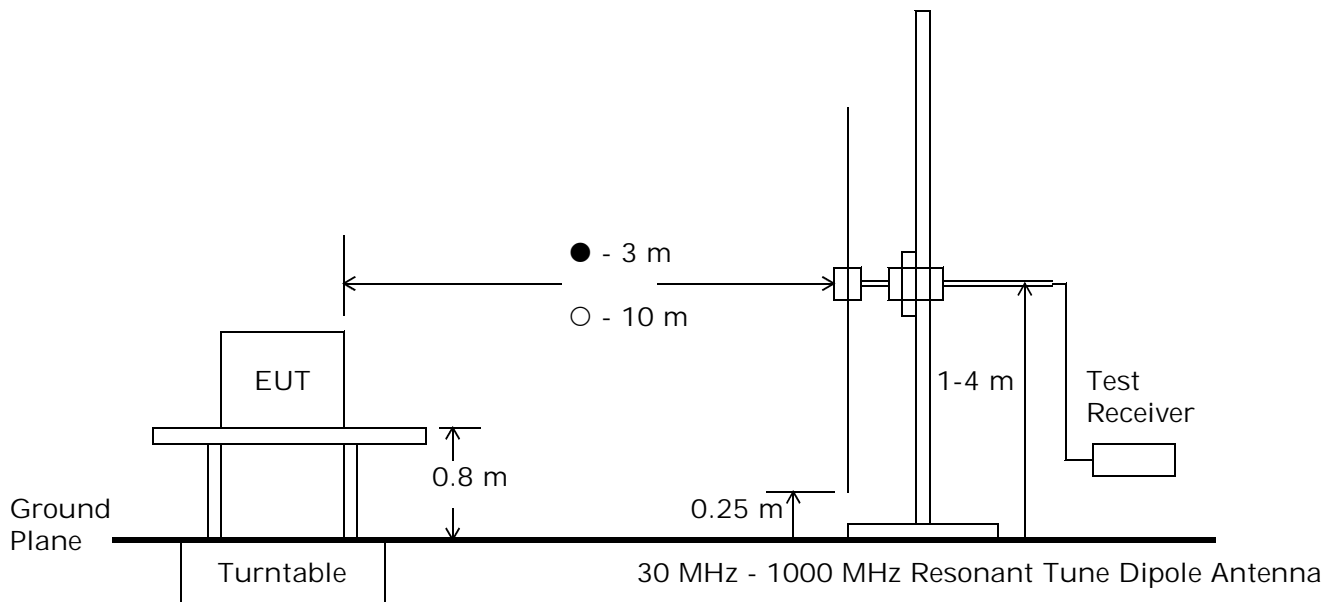

Electromagnetic Field Radiated Emission 1 GHz - 25 GHz:

The preliminary test was performed according to the description of ANSI C63.4-1992 Sec.8.3.1.1 (Preliminary Radiated Emissions Tests) and Sec.6.2.1 (Tabletop Equipment Tests).

The preliminary test was carried out to investigate the frequency of the emission that has the highest amplitude relative to the limits within normal operating modes, cable positions, and a typical system configuration. In order to find out to the maximum emission, the preliminary test and a final test were performed in accordance with the following steps.

Step 1: One operation mode of the test system was setting.

Step 2: In order to investigate the frequencies of maximum emissions, the horn antenna position was approached to the EUT and the significant frequency of the emission's circumstance from the test system were investigated. These data were recorded in the specified frequency band (1 GHz - 25 GHz).

Step 3: The emission's circumstance from the test system was measured in accordance with ANSI C63.4-1992, Sec.8.3.1.2 (Final Radiated Emissions Tests) at each frequency which was found higher emission referred to level vs. frequency on the list and which was measured in the specified distance using the horn antenna. The maximum emission was found by changing the cable positions, the antenna position or cable manipulation under a typical system configuration.

Step 4: Return to step 1, if the other operation mode was possible to be setting.

Step 5: The worst result was reported arranging data of which was obtained and performed by one or plural operation modes as the final test.

At the worst point that has the highest amplitude relative to the limit the repeatability of the level was reconfirmed. The photographs of the tests system setup on the worst point were taken and recorded.

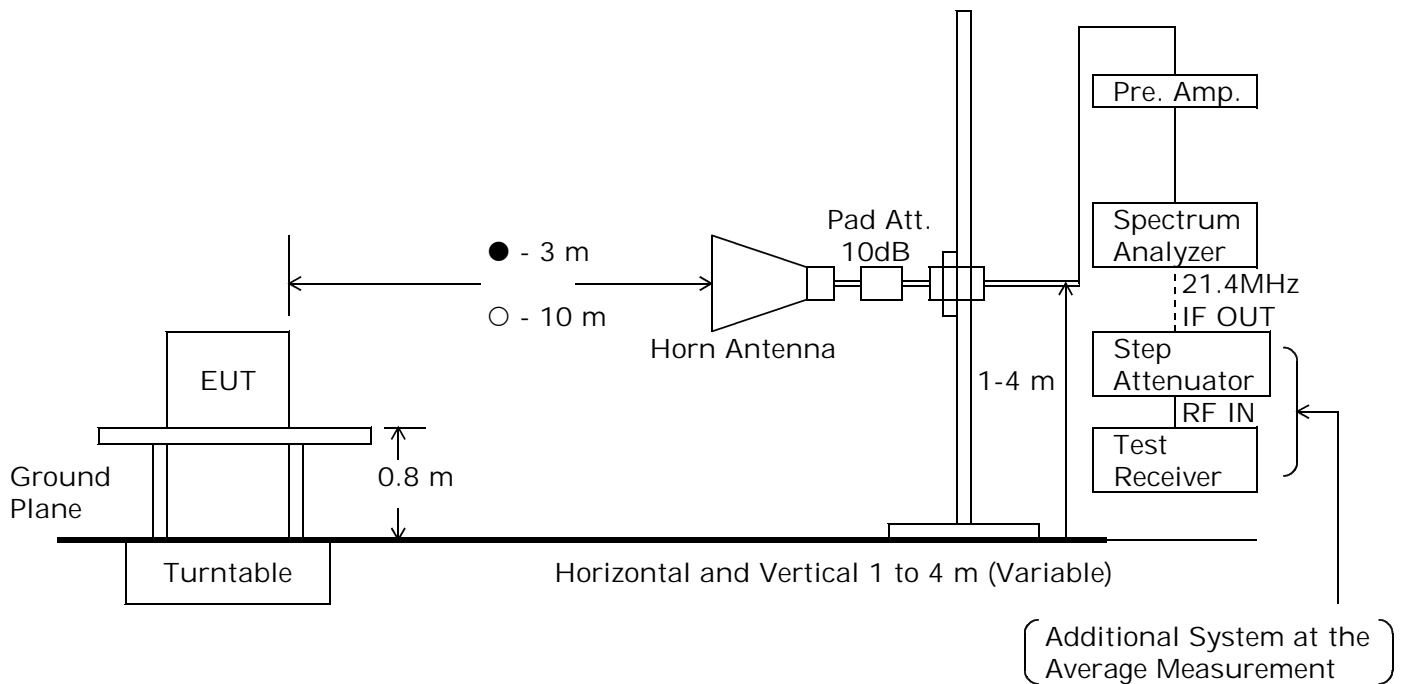

Spectrum Analyzer Setting:

Detector	*)Peak/Average
RES BW	1 MHz
VIDEO BW	1 MHz
SPAN	0 Hz

Test Receiver Setting:

SCALE	LINEAR	LINEAR
I.F.B.W.	1 MHz	1 MHz
Detector	Average	Peak

\*) For the average measurement, it is made using a test receiver and a step attenuator.

**Test-Setup (Photographs) at worst case**

Conducted Emission 450kHz - 30MHz:



Front View

Radiated Emission 9 kHz - 25 GHz



Front View



Side View



Rear View

## AC Powerline Conducted Emission Measurement Intentional Radiator

Test Date: April 11, 2001  
 Temp.: 24 °C ; Humi.: 48 %

**Transmitting Frequency : 2440.800 MHz (46 ch)**

Frequency [MHz]	Corr. Factor [dB]	Meter Readings [dB(μV)]				Limits [dB(μV)]	Results [dB(μV)]		Margin [dB]	Remarks (Note 2)
		VA	AVE	VB	AVE		QP	AVE		
0.45	0.1	< 10.0	--	< 10.0	--	48.0	< 10.1	--	> +37.9	A
1.00	0.1	< 10.0	--	< 10.0	--	48.0	< 10.1	--	> +37.9	A
3.50	0.3	< 10.0	--	< 10.0	--	48.0	< 10.3	--	> +37.7	A
6.00	0.4	12.0	--	12.0	--	48.0	12.4	--	+35.6	A
7.40	0.4	30.0	--	30.0	--	48.0	30.4	--	+17.6	A
10.00	0.5	< 10.0	--	< 10.0	--	48.0	< 10.5	--	> +37.5	A
20.00	0.8	< 10.0	--	< 10.0	--	48.0	< 10.8	--	> +37.2	A
30.00	0.9	< 10.0	--	< 10.0	--	48.0	< 10.9	--	> +37.1	A

Sample of calculated result at 7.40 MHz, as the Minimum Margin point:

Correction Factor = 0.4 dB  
 +) Meter Reading = 30.0 dB(μV)  
 Result = 30.4 dB(μV)

Minimum Margin : 48.0 - 30.4 = 17.6(dB)

The point shown on " \_\_\_ " is the Minimum Margin Point.

Note 1:

1)The correction factor includes the LISN insertion loss and the cable loss.

**Remarks:**

Note 2	Detector Function	IF Bandwidth
A	CISPR QP	9 kHz
B	Average	10 kHz

Tester : Hiroshi Fujimoto

## Electromagnetic Field Radiated Emission Measurement

Intentional Radiator

Spurious emission except fundamental and harmonics(9kHz - 1GHz)

Test Date: April 11, 2001

Temp.: 27 °C ; Humi.: 34 %

**Transmitting Frequency : 2440.800 MHz (46 ch)**

Frequency [MHz]	Antenna Factor [dB(1/m)]	Cable Loss [dB]	Meter Readings [dB(μV)]		Limits [dB(μV/m)]	Results [dB(μV/m)]		Margin [dB]	Remarks (Note 2)
			Hori.	Vert.		Hori.	Vert.		
72.6	6.1	1.5	15.0	16.0	40.0	22.6	23.6	+16.4	A
82.9	7.3	1.5	17.0	15.0	40.0	25.8	23.8	+14.2	A
124.4	10.8	1.9	14.0	18.0	43.5	26.7	30.7	+12.8	A
145.2	12.1	2.1	17.0	21.0	43.5	31.2	35.2	+ 8.3	A
269.6	17.5	2.9	18.0	14.0	46.0	38.4	34.4	+ 7.6	A
300.7	18.4	3.1	11.0	8.0	46.0	32.5	29.5	+13.5	A
362.9	20.2	3.5	6.0	8.0	46.0	29.7	31.7	+14.3	A
404.4	21.2	3.7	10.0	4.0	46.0	34.9	28.9	+11.1	A
539.2	24.0	4.4	< -2.0	< 0.0	46.0	< 26.4	< 28.4	> +17.6	A
622.1	25.4	4.8	< -2.0	< -1.0	46.0	< 28.2	< 29.2	> +16.8	A

Sample of calculated result at 269.6 MHz, as the Minimum Margin point:

Antenna Factor	=	17.5 dB(1/m)
Cable Loss	=	2.9 dB
+) Meter Reading	=	18.0 dB(μV)
Result	=	38.4 dB(μV/m)

Minimum Margin : 46.0 - 38.4 = 7.6(dB)

The point shown on " \_\_\_\_ " is the Minimum Margin Point.

Note 1:

- 1)The highest frequency generated or used in the EUT: 2479.680 MHz
- 2)The upper frequency of measurement range : 25 GHz

**Remarks:**

Note 2	Detector Function	IF Bandwidth
A	CISPR QP	120 kHz
B	Average	120 kHz
C	Average	12 kHz
D	Average	7.5 kHz

Tester : Hiroshi Fujimoto

Electromagnetic Field Radiated Emission Measurement  
 Intentional Radiator  
 Fundamental and Spurious(above 1 GHz )

Test Date: April 3, 2001  
 Temp.: 22 °C ; Humi.: 48 %

**Transmitting Frequency : 2401.056 MHz (00ch)**

Frequency [MHz]	Antenna Factor [dB(1/m)]	Cable Loss [dB]	Meter Readings at 3m [dB(μV)]		Limits [dB(μV/m)]	Results at 3m [dB(μV/m)]		Margin [dB]	Remarks (Note 2)
			Hori.	Vert.		Hori.	Vert.		
<b>Fundamental</b>									
2401.056	21.5	1.0	95.0	98.5	---	117.5	121.0	---	E
<b>Spurious at Peak Detector</b>									
* 4802.112	27.3	-21.2	50.5	57.0	74.0	56.6	63.1	+10.9	G
7203.168	29.9	-29.7	60.0	61.0	101.0	60.2	61.2	+39.8	E
9604.224	33.4	-37.6	56.0	57.0	101.0	51.8	52.8	+48.2	E
* 12005.280	33.6	-36.8	54.0	57.0	74.0	50.8	53.8	+20.2	G
14406.336	37.1	-36.4	52.0	54.0	101.0	52.7	54.7	+46.3	E
16807.392	37.2	-37.0	< 50.0	< 50.0	101.0	< 50.2	< 50.2	> +50.8	G
* 19208.448	40.2	-28.8	< 50.0	< 50.0	74.0	< 61.4	< 61.4	> +12.6	E
21609.504	40.3	-29.1	< 50.0	< 50.0	101.0	< 61.2	< 61.2	> +39.8	E
24010.560	40.4	-29.6	< 50.0	< 50.0	101.0	< 60.8	< 60.8	> +40.2	E
<b>Spurious at Average Detector</b>									
* 4802.112	27.3	-21.2	32.5	37.0	54.0	38.6	43.1	+10.9	F
* 12005.280	33.6	-36.8	36.0	38.0	54.0	32.8	34.8	+19.2	F
* 19208.448	40.2	-28.8	< 35.0	< 35.0	54.0	< 46.4	< 46.4	> + 7.6	F

**Transmitting Frequency : 2440.800 MHz (46ch)**

Frequency [MHz]	Antenna Factor [dB(1/m)]	Cable Loss [dB]	Meter Readings at 3m [dB(μV)]		Limits [dB(μV/m)]	Results at 3m [dB(μV/m)]		Margin [dB]	Remarks (Note 2)
			Hori.	Vert.		Hori.	Vert.		
<b>Fundamental</b>									
2440.800	21.5	1.0	95.0	100.0	---	117.5	122.5	---	E
<b>Spurious at Peak Detector</b>									
* 4881.600	27.3	-21.3	54.0	56.0	74.0	60.0	62.0	+12.0	G
* 7322.400	29.9	-29.5	64.0	64.0	102.5	64.4	64.4	+38.1	G
9763.200	33.5	-37.5	55.0	55.0	102.5	51.0	51.0	+51.5	E
* 12204.000	33.6	-36.7	57.0	57.0	74.0	53.9	53.9	+20.1	G
14644.800	37.1	-36.5	< 50.0	51.0	102.5	< 50.6	51.6	+50.9	E
17085.600	37.2	-37.1	< 50.0	< 50.0	102.5	< 50.1	< 50.1	> +52.4	E
* 19526.400	40.3	-28.5	< 50.0	< 50.0	74.0	< 61.8	< 61.8	> +12.2	G
21967.200	40.3	-29.2	< 50.0	< 50.0	102.5	< 61.1	< 61.1	> +41.4	E
24408.000	40.4	-29.4	< 50.0	< 50.0	102.5	< 61.0	< 61.0	> +41.5	E
<b>Spurious at Average Detector</b>									
* 4881.600	27.3	-21.3	37.0	38.0	54.0	43.0	44.0	+10.0	F
* 7322.400	29.9	-29.5	38.0	41.0	54.0	38.4	41.4	+12.6	F
* 12204.000	33.6	-36.7	< 35.0	< 35.0	54.0	< 31.9	< 31.9	> +22.1	F
* 19526.400	40.3	-28.5	< 35.0	< 35.0	54.0	< 46.8	< 46.8	> + 7.2	F

**Transmitting Frequency : 2479.680 MHz (91ch)**

Frequency [MHz]	Antenna Factor [dB(1/m)]	Cable Loss [dB]	Meter Readings at 3m [dB(μV)]		Limits [dB(μV/m)]	Results at 3m [dB(μV/m)]		Margin [dB]	Remarks (Note 2)
			Hori.	Vert.		Hori.	Vert.		
<b>Fundamental</b>									
2479.680	21.5	1.0	92.5	98.0	---	115.0	120.5	---	E
<b>Spurious at Peak Detector</b>									
* 4959.360	27.3	-21.3	47.5	50.0	74.0	53.5	56.0	+18.0	G
* 7439.040	30.0	-29.4	56.0	57.0	100.5	56.6	57.6	+42.9	G
9918.720	33.5	-37.5	51.0	50.0	100.5	47.0	46.0	+53.5	E
* 12398.400	33.6	-36.6	< 50.0	< 50.0	74.0	< 47.0	< 47.0	> +27.0	G
14878.080	37.1	-36.6	< 50.0	< 50.0	100.5	< 50.5	< 50.5	> +50.0	E
17357.760	37.2	-37.3	< 50.0	< 50.0	100.5	< 49.9	< 49.9	> +50.6	E
* 19837.440	40.3	-28.8	< 50.0	< 50.0	74.0	< 61.5	< 61.5	> +12.5	G
* 22317.120	40.4	-28.9	< 50.0	< 50.0	100.5	< 61.5	< 61.5	> +39.0	G
24796.800	40.4	-29.6	< 50.0	< 50.0	100.5	< 60.8	< 60.8	> +39.7	E
<b>Spurious at Average Detector</b>									
* 4959.360	27.3	-21.3	< 35.0	< 35.0	54.0	< 41.0	< 41.0	> +13.0	F
* 7439.040	30.0	-29.4	< 35.0	< 35.0	54.0	< 35.6	< 35.6	> +18.4	F
* 12398.400	33.6	-36.6	< 35.0	< 35.0	54.0	< 32.0	< 32.0	> +22.0	F
* 19837.440	40.3	-28.8	< 35.0	< 35.0	54.0	< 46.5	< 46.5	> + 7.5	F
* 22317.120	40.4	-28.9	< 35.0	< 35.0	54.0	< 46.5	< 46.5	> + 7.5	F

Sample of calculated result at 19526.400 MHz, as the Minimum Margin point:

Antenna Factor = 40.3 dB(1/m)  
 Corr. Factor = -28.5 dB  
 +) Meter Reading = <35.0 dB(μV)  
 Result = <46.8 dB(μV/m)

Minimum Margin : 54.0 - <46.8 = >7.2(dB)

The point shown on " \_\_\_ " is the Minimum Margin Point.

Note 1:

- 1)The highest frequency generated or used in the EUT: 2479.680 MHz
- 2)The upper frequency of measurement range : 25 GHz
- 3)The spectrum was scanned 9 kHz to 25 GHz and all emissions not reported were more than 20 dB below the applied limits.
- 4)Symbol '\*\*' : Restricted bands of operation in Sec.15.205.
- 5)Corr. Factor [dB] (below 1 GHz) = Cable Loss [dB]  
 Corr. Factor [dB] (above 1 GHz) = Cable Loss [dB] + 10 dB/20 dB Pad Attenuator [dB] - Pre-Amplifier Gain [dB]

**Remarks:**

Note 2	Detector Function	IF Bandwidth
A	CISPR QP	200 Hz
B	CISPR QP	9 kHz
C	CISPR QP	120 kHz

Note 2	Detector Function	RES. B.W	V.B.W	Sweep T	Span
D	Peak (SP)	1 MHz	1 MHz	20 msec	0 Hz
E	Peak (SP)	100 kHz	300 kHz	20 msec	0 Hz
*) F	Average (Receiver)	1 MHz (1 MHz)	3 MHz	20 msec	0 Hz
G	Peak	1 MHz	3 MHz	20 msec	0 Hz

( ):Setting of spectrum analyzer

\*)For the average/peak measurement method, it is made measurement using a test receiver, a step attenuator or and a spectrum analyzer(FCC REPLY No. 950523A).

Tester : Hiroshi Fujimoto

## Maximum Peak Power (EIRP) Measurement Fundamental Emission

Test Date: April 3, 2001  
 Temp.: 22 °C ; Humi.: 48 %

Measurement Results:

**Radiated Emission Measurement at 3m**

Frequency [MHz] Fundamental	Antenna Factor [dB(1/m)]	Cable Loss [dB]	Meter Readings at 3m [dB(μV)]		Results at 3m [dB(μV/m)]		Remarks (Note 1)
			Hori.	Vert.	Hori.	Vert.	
2401.056	21.5	1.0	95.0	98.5	117.5	121.0	A
2440.800	21.5	1.0	95.0	100.0	117.5	122.5	A
2479.686	21.5	1.0	92.5	98.0	115.0	120.5	A

**Remarks:**

Note 1	Detector Function	RES. B.W	V.B.W	Sweep T	Span
A	Peak	1 MHz	3 MHz	20 msec	0 Hz

Calculated Results:

CH No.	Frequency (MHz)	Maximum Peak Power EIRP(W)		Limits (W)	Margin (dB)
		Hori.	Vert.		
00	2401.056	0.169	0.378	1.000	+4.2
46	2440.800	0.169	0.533	1.000	+2.7
91	2479.686	0.095	0.337	1.000	+4.7

The EUT is placed at 3m away from the receiving antenna and the EIRP is calculated using the following formula:

$$E^2 / (120\pi) = \text{EIRP} / (4\pi d^2) \quad \text{where} \quad \text{EIRP} = P_h G_h, \quad E : \text{Field Strength at } d \text{ (distance) m} [\mu\text{V/m}]$$

$$\text{EIRP} = (dE)^2 / 30 \quad G_h = \text{Substituted Antenna [dBi]}$$

$$\text{EIRP(W)} = (3 \times E(\mu\text{V/m}) \times 10^{-6})^2 / 30 \quad P_h = \text{Input power at the Substituted Antenna [W]}$$

The point shown on " " is the Minimum Margin Point.  
 Minimum Margin Point, as 2440.0800 MHz :  $10\log(1.000 / 0.533) = 2.7 \text{ (dB)}$

Tester : Hiroshi Fujimoto

### Transmitter Power(TP) Measurement

Test Date: April 19, 2001  
 Temp.: 22 °C ; Humi.: 48 %

Measurement Results:

CH No.	Frequency (MHz)	Corr. Factor (dB)	Meter Reading (dBm)	Result (dBm)	Result (W)	Limits (W)	Margin (dB)	Remarks (Note 1)
00	2401.056	10.1	13.3	23.4	0.219	1.000	+6.6	A
46	2440.800	10.1	13.1	23.2	0.209	1.000	+6.8	A
91	2479.686	10.2	12.7	22.9	0.195	1.000	+7.1	A

Sample of calculated result at 2401.056 MHz, as the Minimum Margin point:

$$\begin{aligned}
 &\text{Correction Factor} = 10.1 \text{ dB} \\
 &+) \text{ Meter Reading} = 13.3 \text{ dBm} \\
 &\text{Result} = 23.4 \text{ dBm} \quad ; 10^{(23.4/10)} = 0.219 \text{ (W)}
 \end{aligned}$$

Minimum Margin : 30.0 - 23.4 = 6.6(dB)

The point shown on "\_\_\_" is the Minimum Margin Point.

Note : 1. The correction factor includes the attenuator loss and the cable loss.

**Remarks:**

Note 2	Detector Function	RES. B.W	V.B.W	Sweep T	Span
A	Peak	1 MHz	3 MHz	20 msec	0 Hz

Tester : Shigeru Kinoshita

### Calculated Antenna gain of the EUT

Calculated Results:

Antenna gain of the integrated antenna of the EUT : Geut(dB)  
Transmitter power (Measured) : TP(dBm)  
EIRP (Measured) : EIRP(dBm)

If the antenna gain(Gtut) is met the equations as follows.

$$\begin{aligned} \text{EIRP} &= \text{TP} * \text{Gtut} \\ \text{Geut(Numric)} &= \text{EIRP} / \text{TP} \\ \text{Geut(dB)} &= 10\log_{10}(\text{EIRP} / \text{TP}) \end{aligned}$$

<b>CH No.</b>	<b>Frequency (MHz)</b>	<b>EIRP (W)</b>	<b>TP (W)</b>	<b>Geut (dBi)</b>
00	2401.056	0.378	0.219	2.38
46	2440.800	0.533	0.209	4.07
91	2479.686	0.337	0.195	2.38

Sample of calculated result at 2440.800 MHz, as the Maximum point:

$$\begin{array}{rcl} \text{EIRP} & = & 27.27 \text{ dBm} = 10\log_{10}(0.533) + 30 \\ -) \text{TP} & = & 23.20 \text{ dBm} = 10\log_{10}(0.209) + 30 \\ \hline \text{Result} & = & 4.07 \text{ dBi} \end{array}$$

The point shown on " \_\_\_ " is the Maximum Point.

-20dB bandwidth and Band-edge Emission Measurement  
Fundamental Emission

Test Date: April 10, 2001  
Temp.: 22 °C ; Humi.: 48 %

1) -20dB bandwidth measurement  
Measurement Results:

<b>CH No.</b>	<b>Frequency (MHz)</b>	<b>-20dB bandwidth (kHz)</b>	<b>Attached graph page</b>
00	2401.056	620	page 39
46	2440.800	616	page 40
91	2479.680	616	page 41

The point shown on " " is the Minimum Margin Point.

2) Band-edge Emission measurement  
Measurement Results:

<b>CH No.</b>	<b>Frequency (MHz)</b>	<b>Band-edge Frequency (MHz)</b>	<b>Attached graph page</b>
00	2401.056	2400.000	page 42
91	2479.680	2483.500	page 43

Tester : Hiroshi Fujimoto

**-20dB Bandwidth Measurement**

Transmitting Frequency : 2401.056 MHz (00 ch)

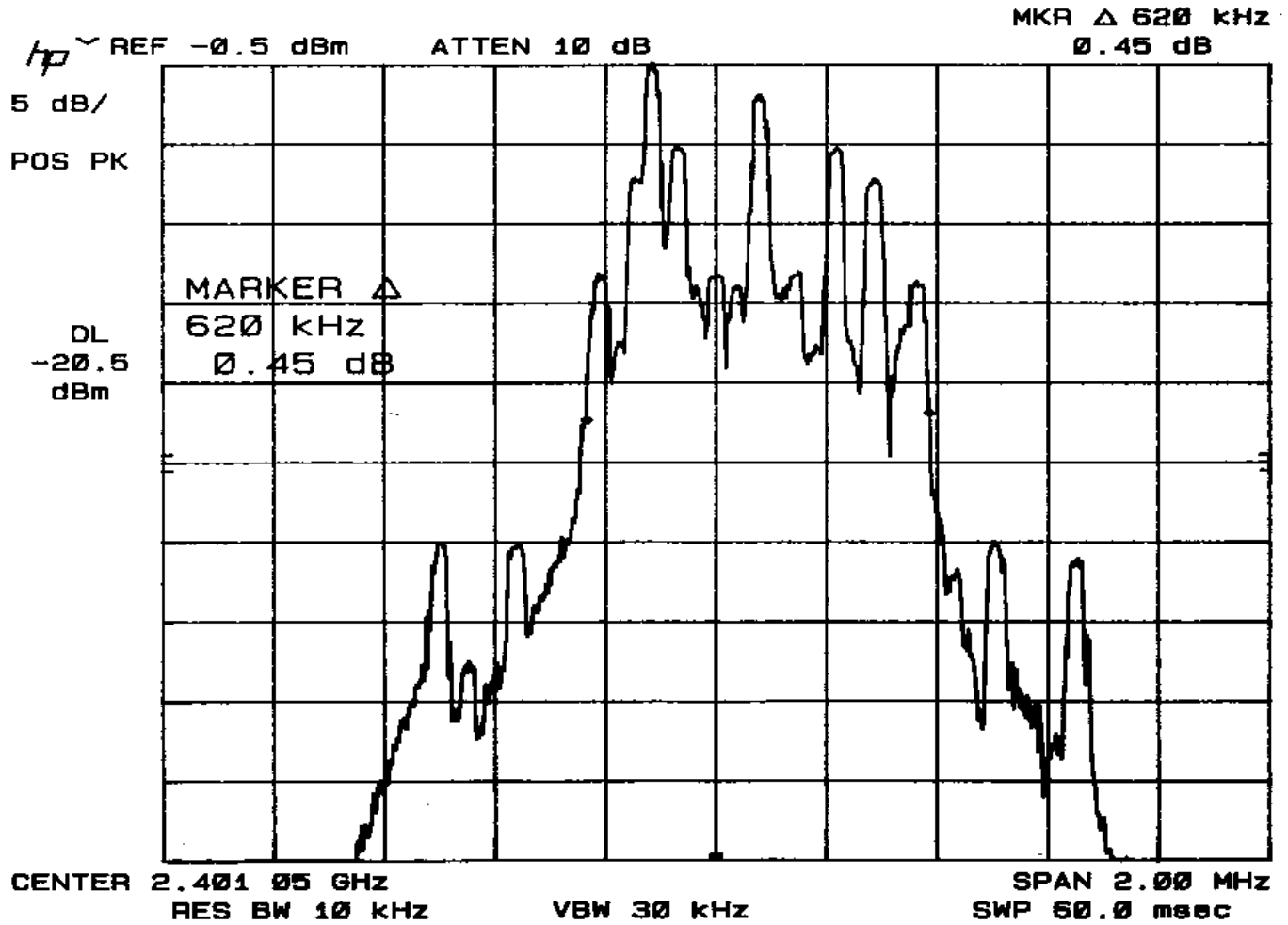

-20dB Bandwidth Measurement

Transmitting Frequency : 2440.800 MHz (46 ch)

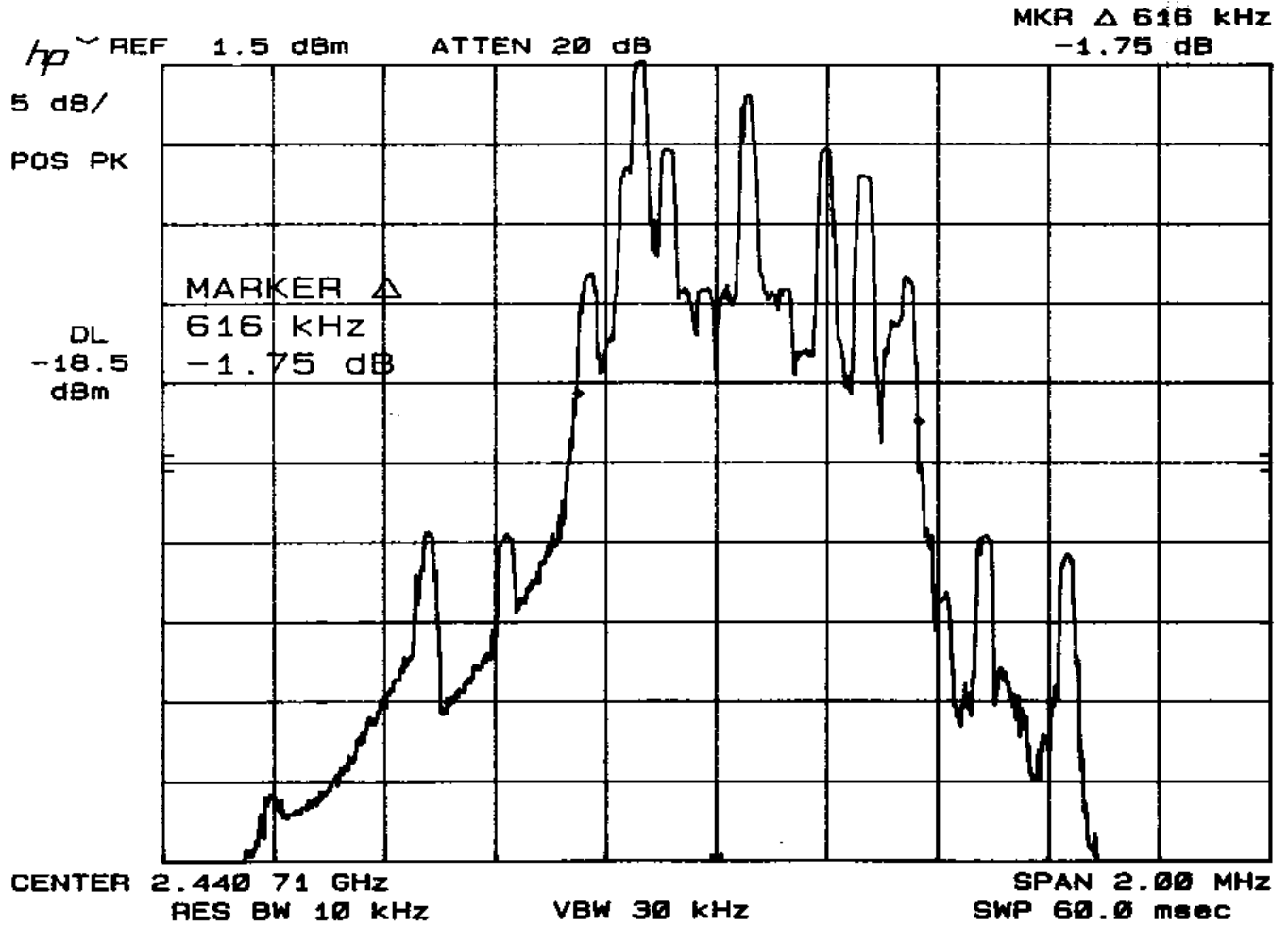

**-20dB Bandwidth Measurement**

Transmitting Frequency : 2479.680 MHz (91 ch)

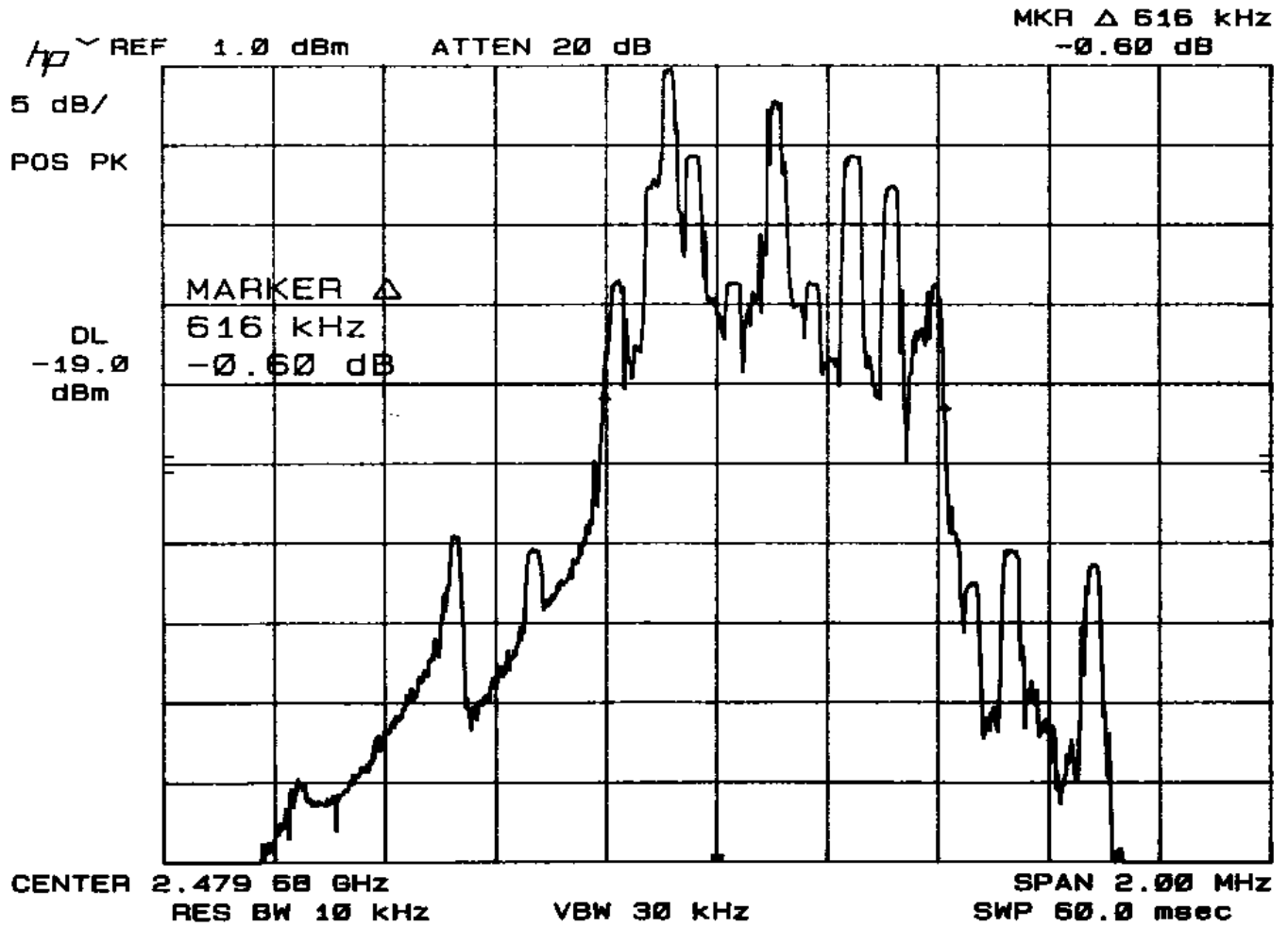

**Band-edge Emission Measurement**

Transmitting Frequency : 2401.056 MHz (00 ch)  
Band-edge Frequency : 2400.000 MHz

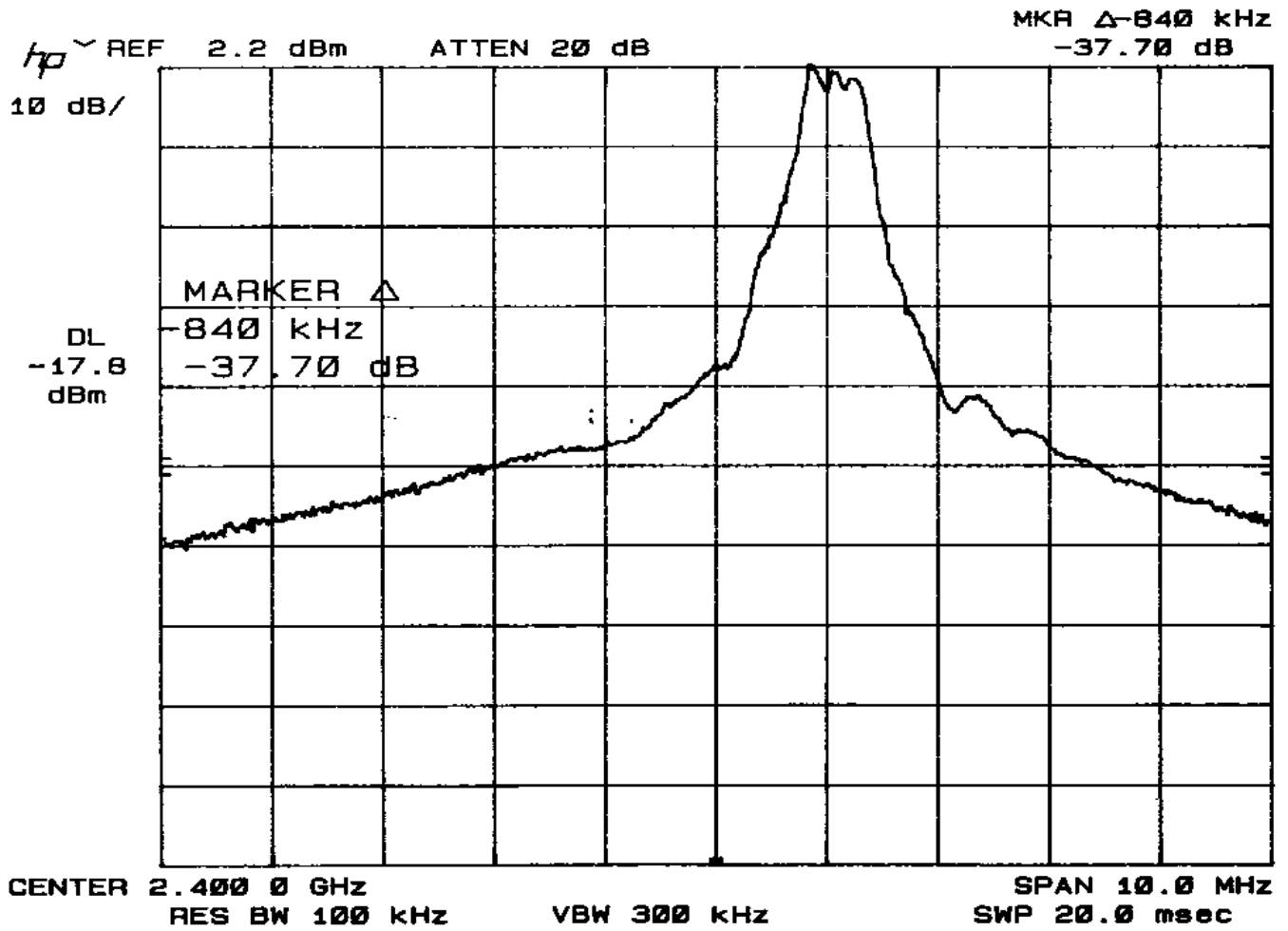

**Band-edge Emission Measurement**

Transmitting Frequency : 2479.680 MHz (91 ch)  
Band-edge Frequency : 2483.500 MHz

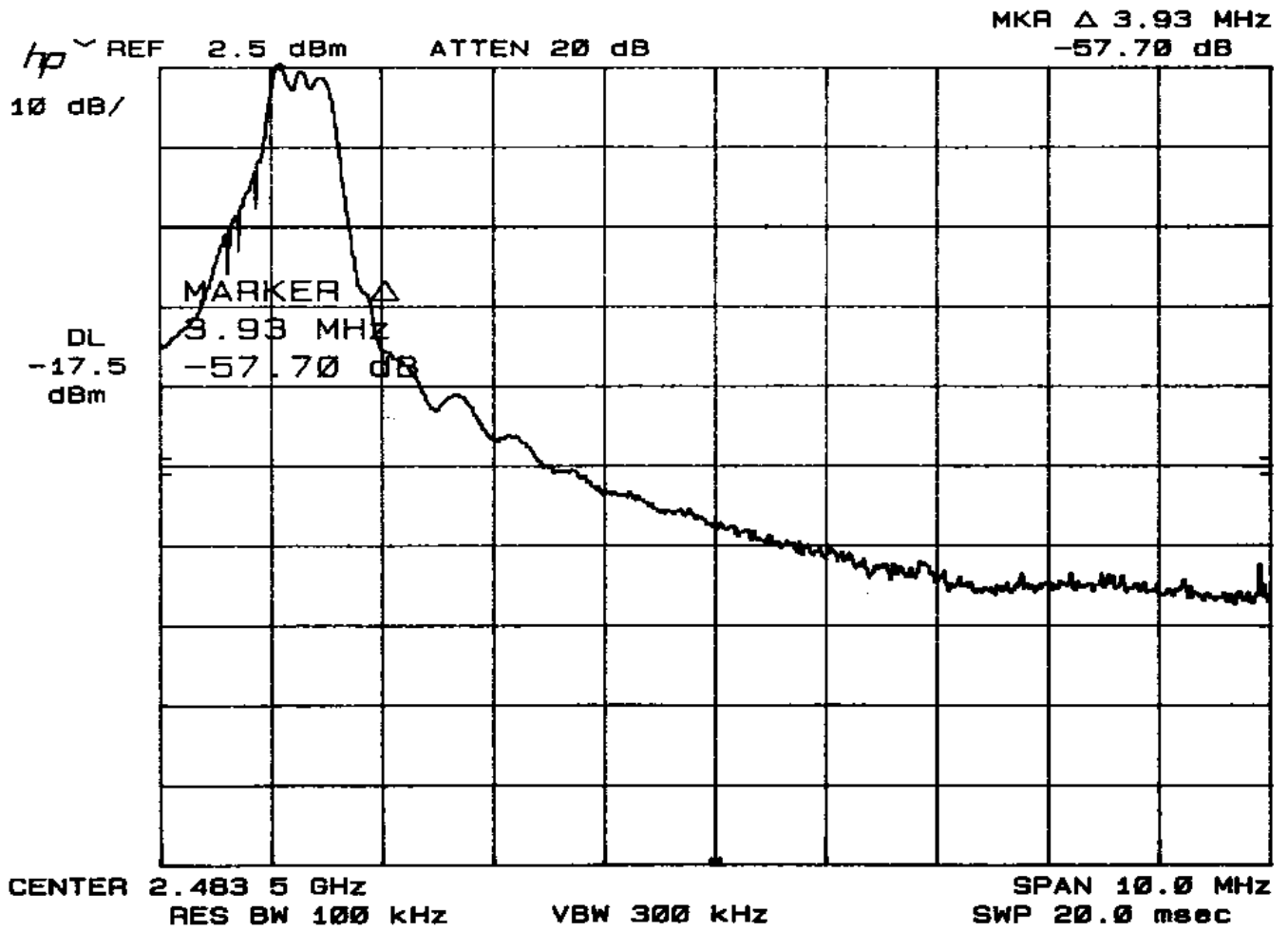

JQA Application No. : KL80010003  
Model No. : KX-TGA420B  
FCC ID : ACJ96NKX-TGA420B

Regulation : CFR 47 FCC Rules Part 15  
Issue Date : April 20, 2001

---

Page 44 of 53

## Carrier Frequency Separation Measurement Fundamental Emission

Test Date: April 10, 2001  
Temp.: 22 °C ; Humi.: 48 %

### Measurement Results:

Transmitting Frequency No.1 : 2439.936 MHz (45 ch)  
Transmitting Frequency No.2 : 2440.800 MHz (46 ch)  
Channel Separation : 860 kHz  
Attached Graph Page : page 45

Tester : Hiroshi Fujimoto

Carrier Frequency Separation Measurement

Transmitting Frequency No.1 : 2439.936 MHz (45 ch)  
Transmitting Frequency No.2 : 2440.800 MHz (46 ch)

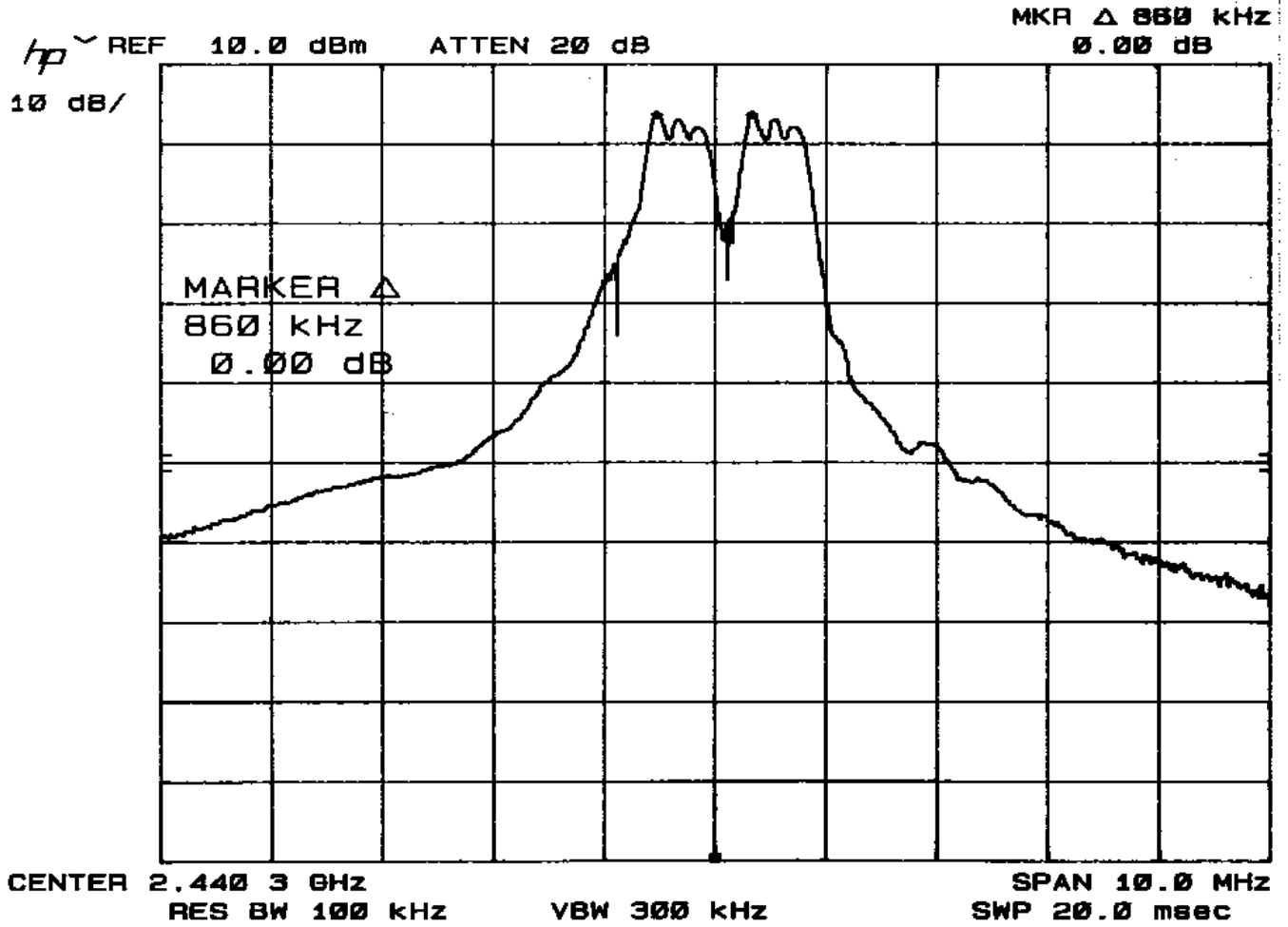

Number of Hopping Frequencies Measurement  
Fundamental Emission

Test Date: April 19, 2001  
Temp.: 22 °C ; Humi.: 48 %

Measurement Results:

Confirmed the number of the hopping frequencies : 100 hops/sec.

Tester : Shigeru Kinoshita

## Time of Occupancy(Dwell time) Measurement Fundamental Emission

Test Date: April 16, 2001  
Temp.: 22 °C ; Humi.: 48 %

### Measurement Results:

1) Pulse width of one slot(as 8 utilized) Measurement

Result : 760.5  $\mu$ sec  
Attached Graph Page : page 48

2) Dwell time measurement of occupancy in a 30 second period.

Results : The average time of occupancy is less than 0.4 seconds within a 30 second period.  
Attached Graph : pages 49 - 51  
:

Tester : Shigeru Kinoshita

Pulse width of one slot(as 8 utilized) Measurement  
Transmitting Frequency : 2479.680 MHz (91 ch)

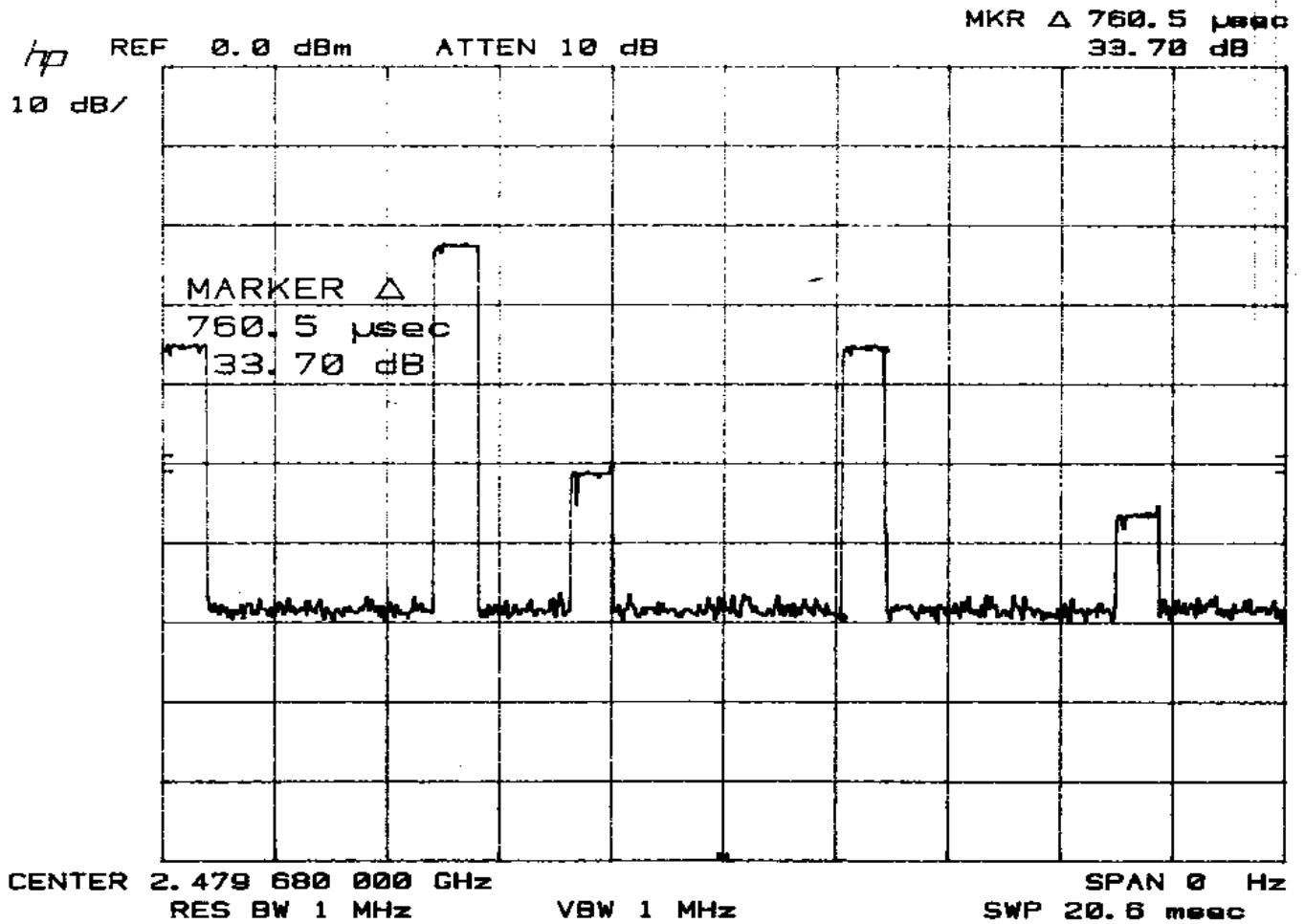

Dwell time measurement of occupancy in a 30 second period.

Transmitting Frequency : 2401.056 MHz (00 ch)

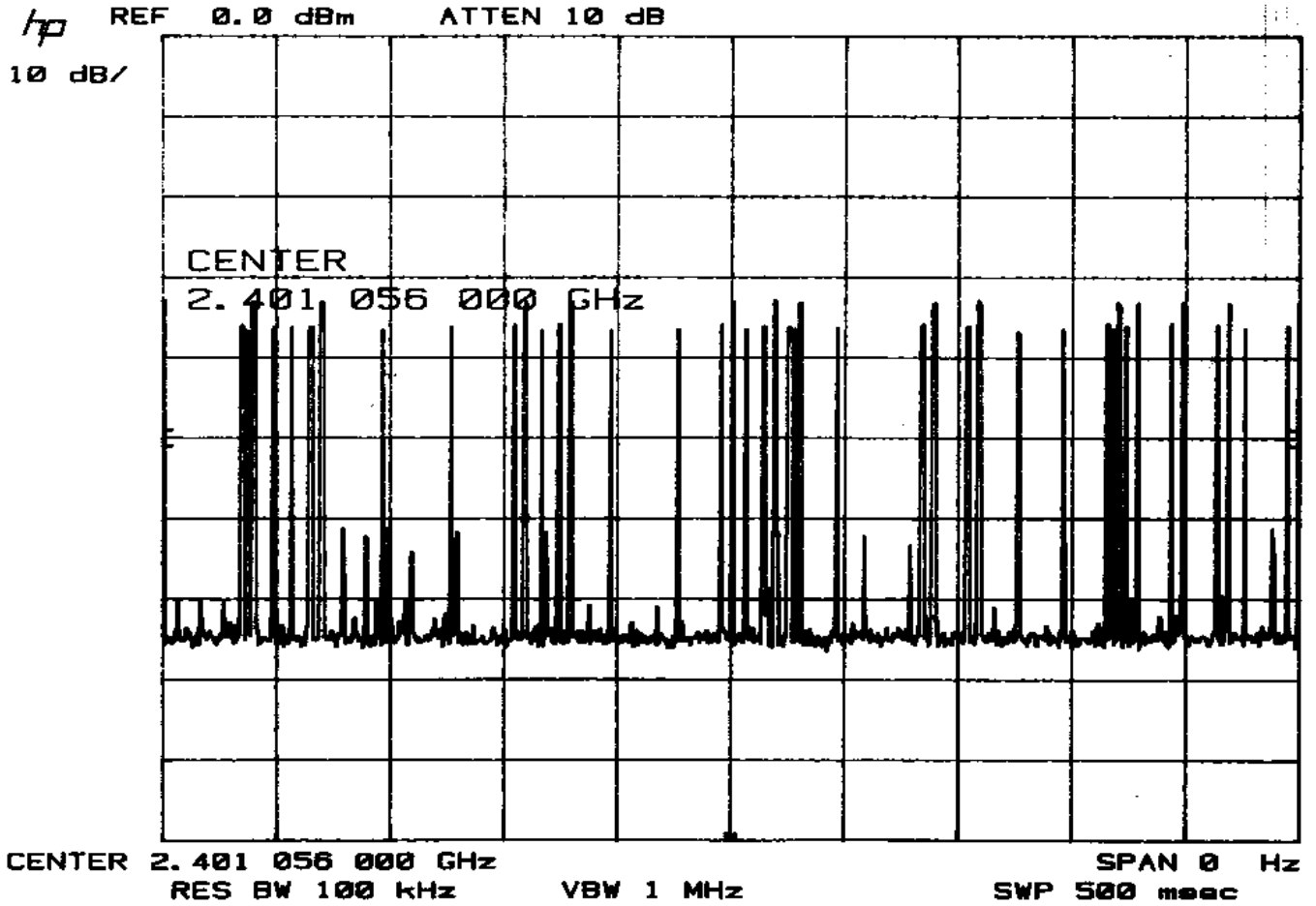

Dwell time measurement of occupancy in a 30 second period.

Transmitting Frequency : 2440.800 MHz (46 ch)

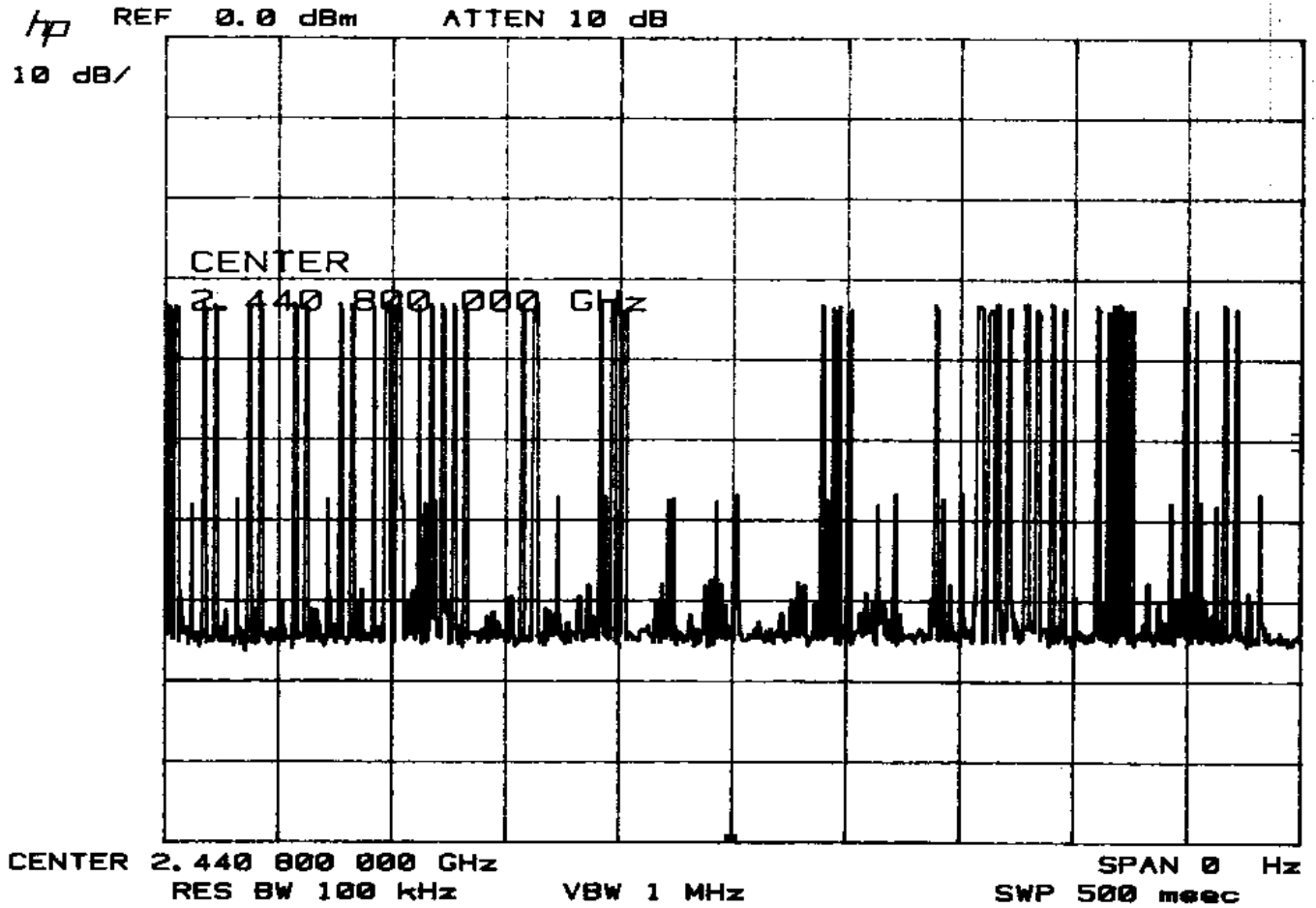

Dwell time measurement of occupancy in a 30 second period.

Transmitting Frequency : 2479.680 MHz (91 ch)

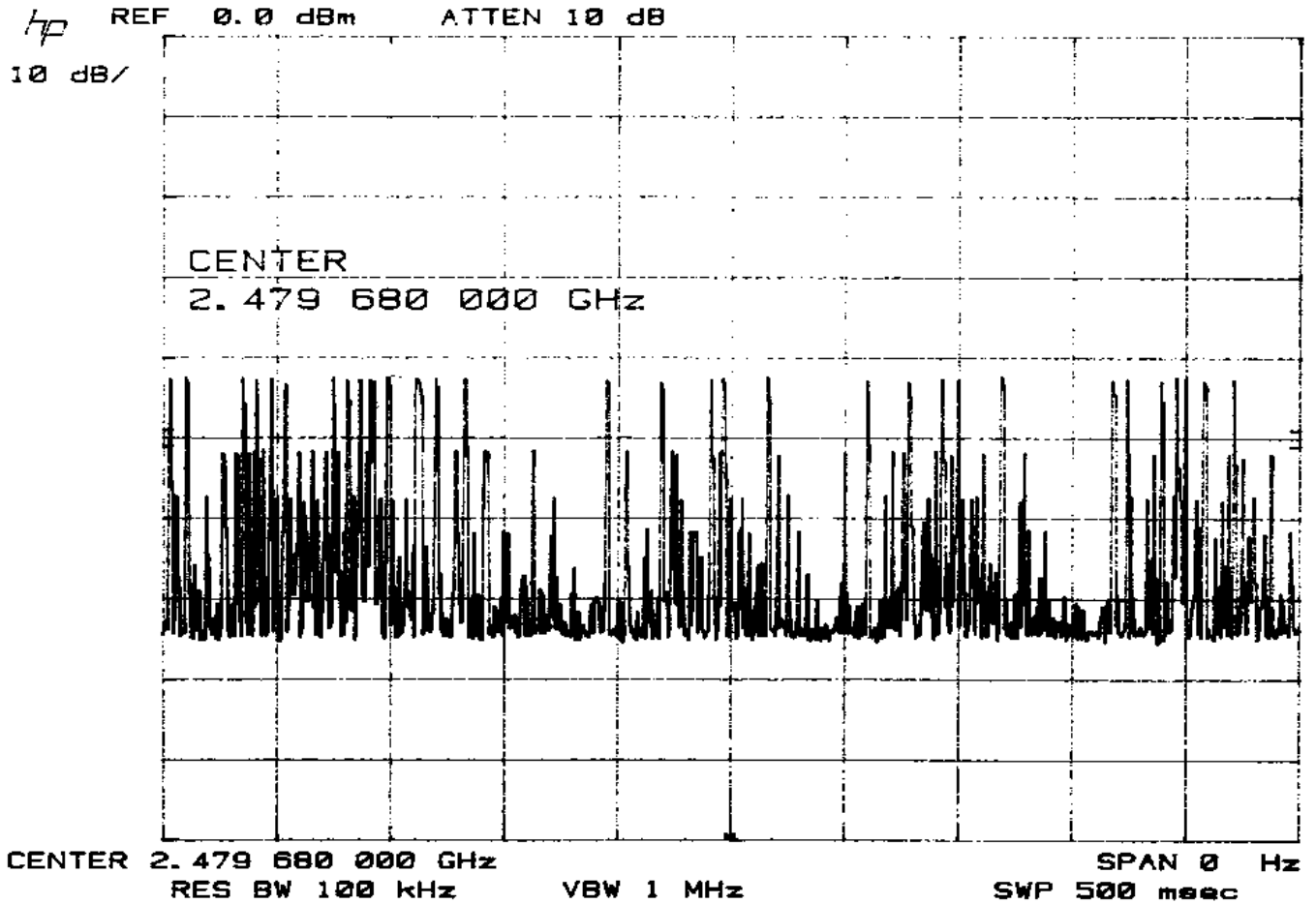

## Sec.247(a)(1)(ii) CHANNEL SEPARATION/DWELL TIME

Compliance with other provision of Sec.15.247 is stated in Kyushu Matsushita Electric Co., Ltd. , as stated below:

Hopping channel carrier frequencies are separated by 864 kHz(Specification).

Each bearer is independent and hops at a rate 100 hops/sec.

The hopping sequence is either table-generated or RNG-generated:

1. A table-generated hop sequence is 75 hops long, each channel is used exactly once in the sequence. Therefore, in a 30 second period each frequency channel is used 40 times in that sequence.
2. An RNG-generated hop sequence is 3000 hops long, each channel is exactly 40 times in the entire sequence. Therefore, in 30 second period each frequency channel is used exactly 40 times in that sequence.

The hopping sequence contains 50 logical channels these are mapped-onto 75 physical channels a mapping table.

The highest channel occupancy, is a FP has 4 traffic bearers(i.e. 8 slots utilized), each using the same hopping sequence. As shown previously, for a given sequence, in a 30 second period each frequency channel is exactly 40 times. A slot of 750ms long, therefore the average time of occupancy on any frequency channel in a 30 second period is :

$$T = 750 \mu\text{sec} \times 40 \times 8 = 240 \text{ msec}$$

As comparison, the lowest channel occupancy is when only a single dummy bearer is being transmitted. Because only the 'A-field' is used on a dummy bearer, the transmission is 167ms long, therefore the average time of occupancy on any frequency channel in a 30 second period is:

$$T = 167 \mu\text{sec} \times 40 \times 1 = 6.68 \text{ sec}$$

## Sec.15.247(g)

In the case of the dummy bearer (which the FP transmitter all the time it is powered up and operating), the hopping sequence cycles through the 75 hops in the selected hopping pattern and the repeats.

In the case of a traffic bearer presented with continuous data (which is the normal case, as this is a voice system), the hopping sequence cycles through the 75 hops in the selected pattern and the repeats.

In the case of a traffic bearer transmitting short bursts(for example, which may happen if a PP has several failed attempts<sup>1</sup> to establish a traffic bearer), then the successive traffic bearers will start on different patterns(because the PSTN is incremented each frame.)

Note, that this system is a voice system and short burst transmissions are not typical.

1 The protocol actually limits the number of re-tries to 11 before giving up on the connection.

## Sec.15.247(h)

There is no coordination between transmitters for the purpose of the avoid the simultaneous occupancy of hopping frequencies by multiple transmitters.

Communication only ever takes place between an FP and a PP, never between two FPs or two PPs. (It is actually impossible for a FP to receive a FP packet or a PP packet, because their respective 'sync-fields' are different).

A FP and a PP that have an active traffic bearer between them, will share a common hopping sequence and hop sequence adaption information (i.e. 'swapped channels'). However, neither the FP nor the PP transmits this information to a 3rd party, for any purpose whatsoever.

This is even true when in a state of bearer hand-over, where the PP is simultaneously 'locked-onto' two FPs. The PP will know both FP's hopping sequences, but it does not share information with either FP.

In actually fact, channel collisions between FPs and PPs can and will take place. These may result in reduced voice quality, but this had to be tolerated.

In the case of 'sequence collisions' (where two transmitters, with overlapping radio cells, are using the same slot, pattern and phase within the pattern), this is detected by multiple consecutive corrupted packets. Each connection that is experiencing sequence collisions will independently attempt the situation (either by pattern changing or by bearer hand-over, as discussed previously).