

MEASUREMENT/TECHNICAL REPORT

Matsushita Electric Industrial Co., Ltd. MODEL TX-D9L51NMF

FCC ID: ACJ93312139

This report concerns (check one): Original grant Class II change
Equipment type: LCD PC Monitor

Unintentional Radiator 47 CFR [10-1-95 Edition] Part 15, Subpart B.

Deferred grant requested per 47 CFR 0.457(d)(1)(ii)? yes no

If yes, defer until:

date

Company Name agrees to notify the Commission by

date

of the intended date of announcement of the product so that the grant can be issued on that date.

Applicant:

Matsushita Electric Industrial Co., Ltd.
6-4-1 Tsujidomoto-machi, Fujisawa-shi, Kanagawa-ken
251-0043 Japan

Phone: +81-466-35-1303

Fax: +81-466-35-5557

Submitted by: *J. Yoda*

 July 19, 1999
Date

(Reviewer): *J. Itoh*

 July 19, 1999
Date

**MEASUREMENT/TECHNICAL REPORT
FCC PART 15, Class B (ANSI C63.4:1992)**

Issued: July 16, 1999

Name and Address of: the Client	Matsushita Electric Industrial co., Ltd. 6-4-1 Tsujidomoto-machi, Fujisawa-shi, Kanagawa-ken 251-0043 Japan
Phone / Fax	+81-466-35-1303 / +81-466-35-5557
Test Item:	LCD PC Monitor
Identification:	TX-D9L51NMF
Serial No.:	FX9220007
Sample No.:	1
Sample Receipt Date:	June 17, 1999
Test Result:	PASS

Report Prepared by:	Cosmos Corporation 319 Akeno, Obata-cho, Watarai-gun, Mie-ken, 519-0501 Japan Phone: +81-596-37-0190 Fax: +81-596-37-3609 Cosmos EMC Lab. 543 Shimesasu, Watarai-cho, Watarai-gun, Mie-ken, 516-2119 Japan Phone: +81-596-64-0888 Fax: +81-596-64-0895
---------------------	---

Tested by:

K. Hasegawa

June 19, 1999
Date

Reviewed by:

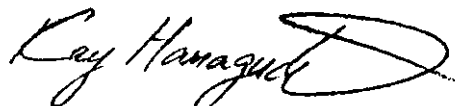
Kay. Hamaguchi

July 16, 1999
Date

Table of Contents **Page**

- 1 GENERAL INFORMATION 5 to 6
 - 1.1 Product Description 5
 - 1.1.1 Rating 5
 - 1.2 Related Submittal(s)/Grant(s) 5
 - 1.3 Test Methodology 5
 - 1.4 Test Facility 5
 - 1.5 Tested System Details 6

- 2 PRODUCT LABELING 7
 - Figure 2.1 FCC ID Label 7
 - Figure 2.2 Location of Label on EUT 7

- 3 SYSTEM TEST CONFIGURATION 8 to 13
 - 3.1 Justification 8
 - 3.2 EUT Exercise Software 8
 - 3.3 Special Accessories 8
 - 3.4 Equipment Modifications 8
 - 3.5 Configuration of Tested System 9 to 13

- 4 BLOCK DIAGRAM(S) OF MODEL TX-D9L51NMF 14
 - 4.1 Figure of Block Diagram of Model TX-D9L51NMF 14

- 5 CONDUCTED AND RADIATED MEASUREMENT PHOTOS 15 to 16

- 6 CONDUCTED EMISSION DATA 17

- 7 RADIATED EMISSION DATA 18

- 8 LIST OF TEST AND MEASUREMENT INSTRUMENT 19

Table of Contents(Continued)	Page
9 PHOTOS OF TESTED EUT	20 to 25
Figure 9.1 Front View	20
Figure 9.2 Rear View	20
Figure 9.3 Top Cover Removed	21
Figure 9.4 Unit Partially Disassembled	21
Figure 9.5 CPU Board, Surface view	22
Figure 9.6 CPU Board, Rear view	22
Figure 9.7 USB Board, Surface view	23
Figure 9.8 USB Board, Rear view	23
Figure 9.9 Power Supply Board, Surface view	24
Figure 9.10 Power Supply Board, Rear view	24
Figure 9.11 High Voltage Board, Surface view	25
Figure 9.12 High Voltage Board, Rear view	25
APPENDIX A	26
Block Diagram of Model TX-D9L51NMF	26

1. General Information

1.1 Product Description

Matsushita Electric Industrial Co., Ltd., Model TX-D9L51NMF (referred to as the EUT in this report) is a LCD PC Monitor.

Clock and power supply switching frequencies are as following:

PARTS	ADDRESS	FUNDAMENTAL FREQUENCY
Crystal Oscillator	IC100	4 MHz

We chose and measured TX-D9L51NMF as representative model in family machines because it was the same circuit construction and performance as them. The followings are family machines.

-Model TX-D9L51F

-Model TX-D9L51****F

1.1.1 Rating

Input Voltage:	AC 100 – 240 V	(AC 120 V)*1
Frequency:	50 / 60 Hz	(60 Hz)*1
Input Current:	1.4 A	(0.5 A)*1

Note: *1 is measured value during test.

1.2 Related Submittal(s)/Grant(s)

Related Submittal Grant is not concerned in this report.

1.3 Test Methodology

Both conducted and radiated testing were performed according to the procedures in ANSI C63.4:1992. Radiated testing was performed at an antenna to EUT distance of 10 meters. Final Result was converted in 3m, using 20 log 10m / 3m.

1.4 Test Facility

The open area test site, Cosmos EMC Lab., and conducted measurement facility used to the radiated data is located at 543 Shimesasu, Watarai-cho, Watarai-gun, Mie-ken, 516-2119, Japan. This site has been fully described in a report dated May 23, 1996 submitted to FCC, and accepted in a letter dated July 10, 1996 (31040/SIT 1300F2).

1.5 Tested System Details

The FCC IDs for all equipment, plus descriptions of all cables used in the tested system(including inserted cards, which have grants) are:

Model No.	Serial No.	FCC ID	Description	Cable Description
TX-D9L51NMF	FX9220007	ACJ93312139	EUT	AC Power Cord 2.0m Unshielded D-Sub Cable 1.8m Shielded Audio Cable 1.8m Shielded
VE6/400 SERIES 8 MT	SG-91002034	Doc	Personal Computer	AC Power Cord 2.2m Unshielded USB Cable 1.8m Shielded Printer Cable 3.0m Shielded
SK-2502	M990233254	GYUR41SK	Keyboard	Keyboard Cable 1.7m Shielded
M-S34	LZB850577	DZL211029	Mouse	Mouse Cable 1.8m Shielded
ECM-S3906	0000095	ECM-S3906	USB Mouse	USB Mouse Cable 1.6m Shielded
ECM-S3906	0000064	ECM-S3906	USB Mouse	USB Mouse Cable 1.6m Shielded
ECM-S3906	0000162	ECM-S3906	USB Mouse	USB Mouse Cable 1.6m Shielded
ECM-S3906	0000164	ECM-S3906	USB Mouse	USB Mouse Cable 1.6m Shielded
LT-100	Unknown	N / A	Stereo Headphone	Headphone Cable 3.0m Shielded
C4565A	SG-73I140TZ	B94C4555X	Printer	AC Power Cord 1.8m Unshielded
5300AM	2195912A	BFJ5300AM	Modem	Modem Cable 1.0m Shielded
T41-090800- A01	52-00042	None	AC Adapter	DC Power Cord 1.8m Unshielded

3. System Test Configuration

3.1 Justification

EUT was measured by max radiation mode user specified.

3.2 EUT Exercise Software

EUT did not use exercise program during radiated and conducted testing.

3.3 Special Accessories

This cable model and part numbers are instructed with their installation manual.

3.4 Equipment Modifications

No equipment modification to achieve compliance to Class B levels was done during test.

3. System Test Configuration (Continued)

3.5 Configuration of Tested System (Continued)

Conducted Emission

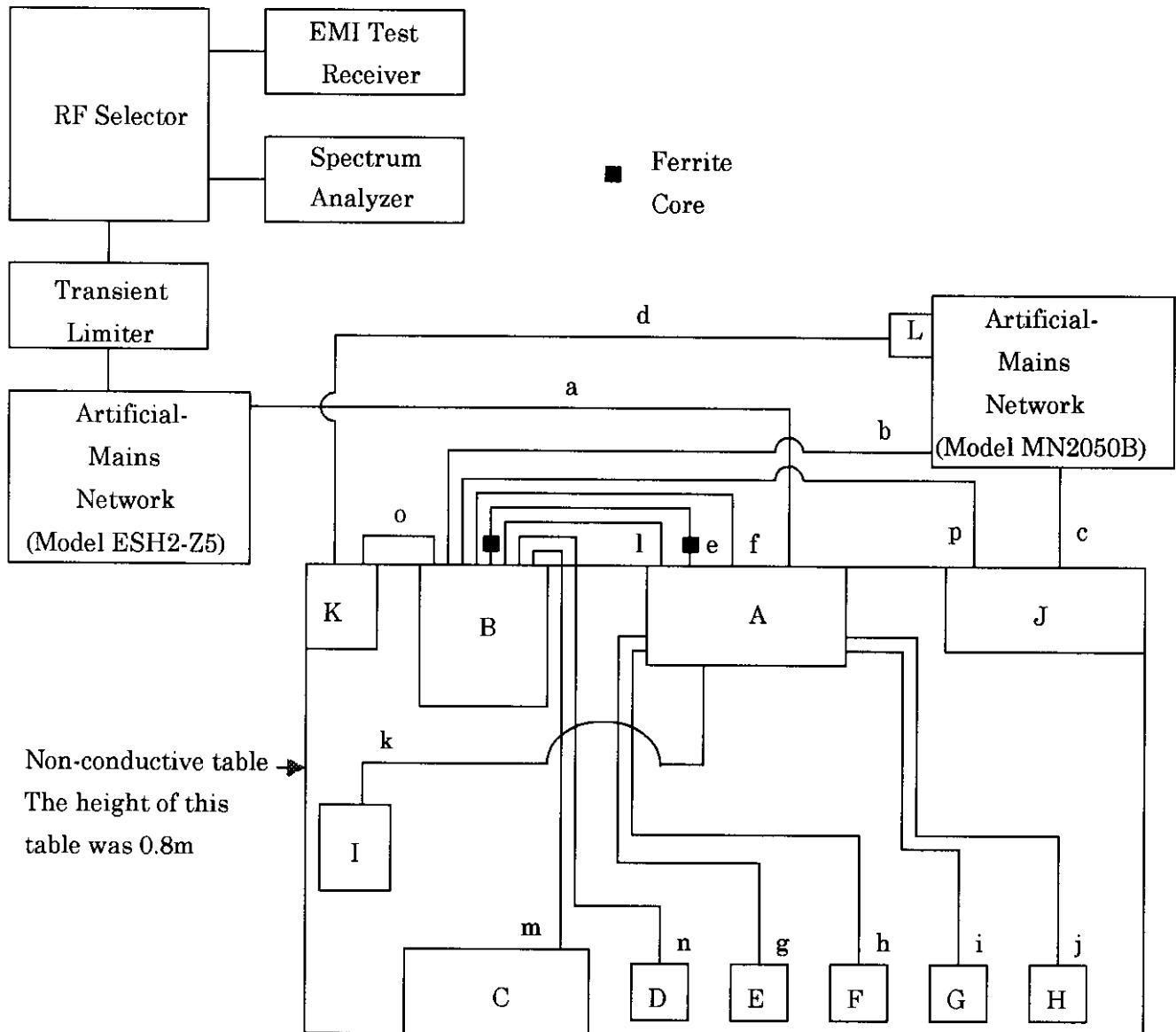

3. System Test Configuration (Continued)

3.5 Configuration of Tested System (Continued)

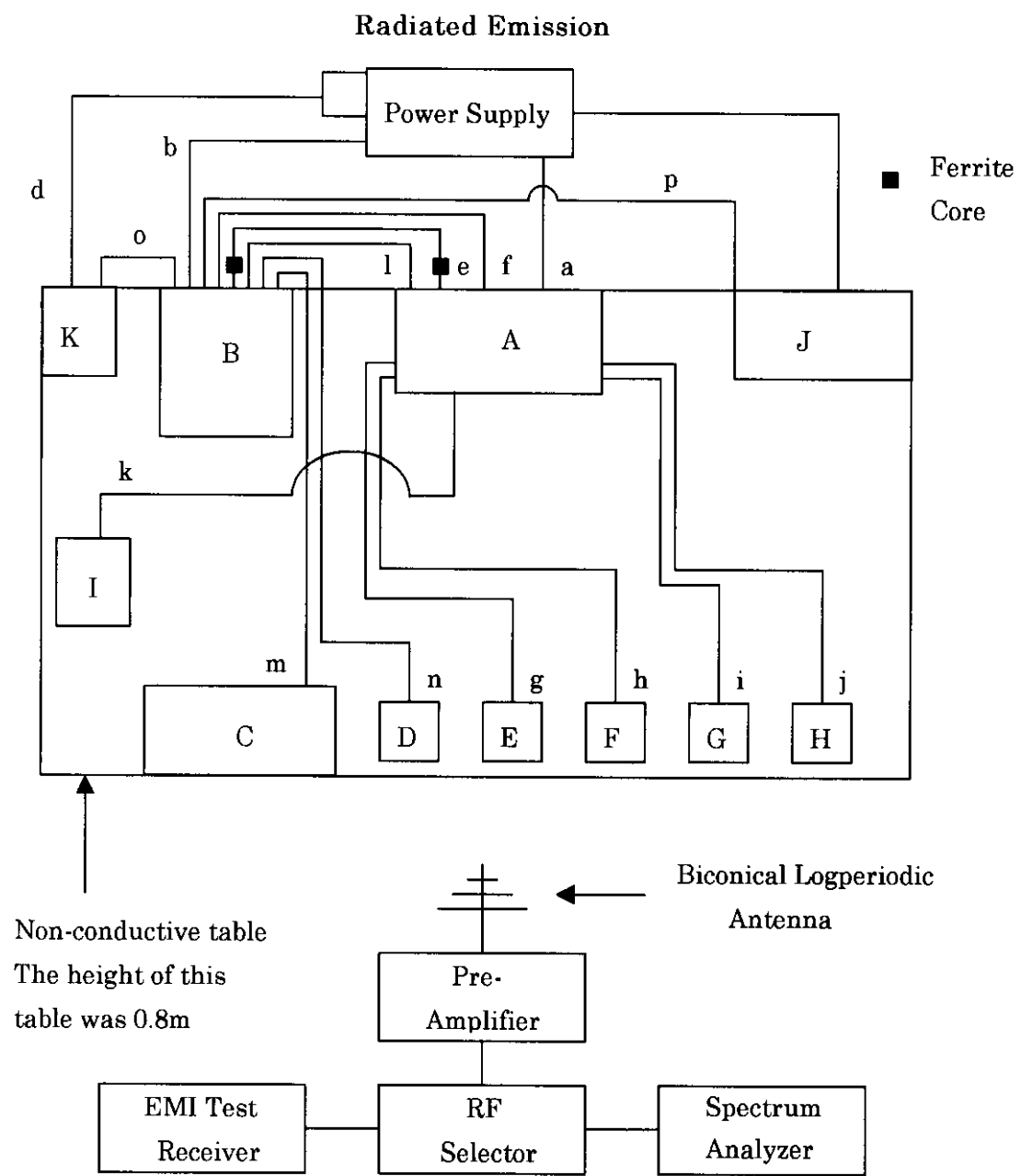

3. System Test Configuration (Continued)

3.5 Configuration of Tested System (Continued)

Independent modes of operation are:

- A) Continuous Operating (Resolution: 1280 × 1024 "H" Pattern)
- B) Continuous Operating (Resolution: 640 × 480 "H" Pattern)

Conducted Emission

- 1) EUT and Personal Computer located at 0.1m intervals.
- 2) EUT and Printer located at 0.1m intervals.
- 3) Personal Computer and Modem located at 0.1m intervals.
- 4) Keyboard and Mouse located at 0.1m intervals.
- 5) Mouse and USB Mouse (S/N: 0000095) located at 0.1m intervals.
- 6) USB Mouse (S/N: 0000095) and USB Mouse (S/N: 0000064) located at 0.1m intervals.
- 7) USB Mouse (S/N: 0000064) and USB Mouse (S/N: 0000162) located at 0.1m intervals.
- 8) USB Mouse (S/N: 0000162) and USB Mouse (S/N: 0000164) located at 0.1m intervals.
- 9) EUT, Personal Computer, Keyboard, Mouse, USB Mouse (S/N: 0000095) ,
USB Mouse (S/N: 0000064), USB Mouse (S/N: 0000162), USB Mouse (S/N: 0000164),
Stereo Headphone, Printer and Modem were put on the Non-conductive table.
- 10) AC Adapter was installed in Artificial-Mains Network (Model MN2050B).
- 11) EUT was connected to Artificial-Mains Network (Model ESH2-Z5) with AC Power Cord.
- 12) Personal Computer was connected to Artificial-Mains Network (Model MN2050B)
with AC Power Cord.
- 13) Printer was connected to Artificial-Mains Network (Model MN2050B) with AC
Power Cord.
The Excess Cord was folded back and forth forming a bundle 0.35m length at the center of
the Cord and the Cord was hung in the middle between ground and table.
- 14) Modem was connected to AC Adapter with DC Power Cord.
- 15) EUT was connected to Personal Computer with D-Sub Cable.
The Excess Cord was folded back and forth forming a bundle 0.35m length at the center of
the Cord and the Cord was hung in the middle between ground and table.
- 16) EUT was connected to Personal Computer with USB Cable.
The Excess Cord was folded back and forth forming a bundle 0.3m length at the center of
the Cord and the Cord was hung in the middle between ground and table.
- 17) EUT was connected to USB Mouse (S/N: 0000095) with USB Cable.
- 18) EUT was connected to USB Mouse (S/N: 0000064) with USB Cable.
- 19) EUT was connected to USB Mouse (S/N: 0000162) with USB Cable.
- 20) EUT was connected to USB Mouse (S/N: 0000164) with USB Cable.
- 21) EUT was connected to Stereo Headphone with Headphone Cable.
- 22) EUT was connected to Personal Computer with Audio Cable.
The Excess Cord was folded back and forth forming a bundle 0.3m length at the center of
the Cord and the Cord was hung in the middle between ground and table.

3. System Test Configuration (Continued)

3.5 Configuration of Tested System (Continued)

- 23) Personal Computer was connected to Keyboard with Keyboard Cable.
- 24) Personal Computer was connected to Mouse with Mouse Cable.
- 25) Personal Computer was connected to Modem with Modem Cable.
- 26) Personal Computer was connected to Printer with Printer Cable.
The Excess Cord was folded back and forth forming a bundle 0.4m length at the center of the Cord and the Cord was hung in the middle between ground and table.

Radiated Emission

- 1) EUT and Personal Computer located at 0.1m intervals.
- 2) EUT and Printer located at 0.1m intervals.
- 3) Personal Computer and Modem located at 0.1m intervals.
- 4) Keyboard and Mouse located at 0.1m intervals.
- 5) Mouse and USB Mouse (S/N: 0000095) located at 0.1m intervals.
- 6) USB Mouse (S/N: 0000095) and USB Mouse (S/N: 0000064) located at 0.1m intervals.
- 7) USB Mouse (S/N: 0000064) and USB Mouse (S/N: 0000162) located at 0.1m intervals.
- 8) USB Mouse (S/N: 0000162) and USB Mouse (S/N: 0000164) located at 0.1m intervals.
- 9) EUT, Personal Computer, Keyboard, Mouse, USB Mouse (S/N: 0000095) ,
USB Mouse (S/N: 0000064), USB Mouse (S/N: 0000162), USB Mouse (S/N: 0000164),
Stereo Headphone, Printer and Modem were put on the Non-conductive table.
- 10) AC Adapter was installed in Power Supply.
- 11) EUT was connected to Power Supply with AC Power Cord.
- 12) Personal Computer was connected to Power Supply with AC Power Cord. The Excess Cord was folded back and forth forming a bundle 0.35m length at the center of the Cord.
- 13) Printer was connected to Power Supply with AC Power Cord.
- 14) Modem was connected to AC Adapter with DC Power Cord.
The Excess Cord was folded back and forth forming a bundle 0.35m length at the end of the Cord.
- 15) EUT was connected to Personal Computer with D-Sub Cable.
The Excess Cord was folded back and forth forming a bundle 0.35m length at the center of the Cord and the Cord was hung in the middle between ground and table.
- 16) EUT was connected to Personal Computer with USB Cable.
The Excess Cord was folded back and forth forming a bundle 0.3m length at the center of the Cord and the Cord was hung in the middle between ground and table.
- 17) EUT was connected to USB Mouse (S/N: 0000095) with USB Cable.
- 18) EUT was connected to USB Mouse (S/N: 0000064) with USB Cable.
- 19) EUT was connected to USB Mouse (S/N: 0000162) with USB Cable.
- 20) EUT was connected to USB Mouse (S/N: 0000164) with USB Cable.
- 21) EUT was connected to Stereo Headphone with Headphone Cable.

3. System Test Configuration (Continued)

3.5 Configuration of Tested System (Continued)

- 22) EUT was connected to Personal Computer with Audio Cable.
The Excess Cord was folded back and forth forming a bundle 0.3m length at the center of the Cord and the Cord was hung in the middle between ground and table.
- 23) Personal Computer was connected to Keyboard with Keyboard Cable.
- 24) Personal Computer was connected to Mouse with Mouse Cable.
- 25) Personal Computer was connected to Modem with Modem Cable.
- 26) Personal Computer was connected to Printer with Printer Cable.
The Excess Cord was folded back and forth forming a bundle 0.4m length at the center of the Cord and the Cord was hung in the middle between ground and table.

	Instrument		Cord / Cable
A)	EUT	a)	AC Power Cord 2.0m Unshielded
B)	Personal Computer	b)	AC Power Cord 2.2m Unshielded
C)	Keyboard	c)	AC Power Cord 1.8m Unshielded
D)	Mouse	d)	DC Power Cord 1.8m Unshielded
E)	USB Mouse	e)	D-Sub Cable 1.8m Shielded
F)	USB Mouse	f)	USB Cable 1.8m Shielded
G)	USB Mouse	g)	USB Mouse Cable 1.6m Shielded
H)	USB Mouse	h)	USB Mouse Cable 1.6m Shielded
I)	Stereo Head Phone	i)	USB Mouse Cable 1.6m Shielded
J)	Printer	j)	USB Mouse Cable 1.6m Shielded
K)	Modem	k)	Headphone Cable 3.0m Shielded
L)	AC Adapter	l)	Audio Cable 1.8m Shielded
		m)	Keyboard Cable 1.7m Shielded
		n)	Mouse Cable 1.8m Shielded
		o)	Modem Cable 1.0m Shielded
		p)	Printer Cable 3.0m Shielded

4. Block Diagram(s) of Model TX-D9L51NMF

4.1 Figure of Block Diagram of Model TX-D9L51NMF

See APPENDIX A

6. Conducted Emission Data

6.1 The initial step in collecting conducted data is a spectrum analyzer peak scan of the measurement range. Significant peaks are then marked as shown on the following data page, and these signals are then quasi-peaked.

The measurement was conducted for the resolution 640×480 and 1280×1024 .

The Video I/F Cable was conducted in D-Sub = D-Sub 1.5m length or D-Sub = D-Sub 1.8m length

Following is the worst condition:

B) Continuous Operating (Resolution: 640×480 "H" Pattern)

Dot Clock Frequency : 25.17 MHz

Vertical Frequency : 60 Hz

Horizontal Frequency : 31.5kHz

Video I/F Cable : D-Sub = D-Sub 1.8m length

	Frequency (MHz)	Measured * (dB μ V)	Limit (dB μ V)
Neutral Line	0.45283	28.7	48.0
Neutral Line	0.50002	25.3	48.0
Neutral Line	0.60335	35.8	48.0
Neutral Line	0.90169	31.9	48.0
Neutral Line	1.30682	28.9	48.0
Neutral Line	1.80879	28.6	48.0
L Line	0.45081	28.0	48.0
L Line	0.60208	33.0	48.0
L Line	0.90345	28.8	48.0
L Line	1.05486	27.3	48.0
L Line	17.89525	24.6	48.0
L Line	18.19691	23.3	48.0

* All readings are quasi-peak unless stated otherwise.

Uncertainty of measurement result: ± 2.26 dB

Environment:

Temperature 26 °C

Humidity 58 %

Tested Personnel:

Tester Signature Kouhei Hasegawa

Typed/Printed Name Kouhei Hasegawa

7. Radiated Emission Data

7.1 The following data lists the significant emission frequencies, measured levels, correction factor (includes cable and antenna corrections), the corrected reading, plus the limit.

Explanation of the Correction Factor is given in paragraph.

The measurement was conducted for the resolution 640×480 and 1280×1024 .

The Video I/F Cable was conducted in D-Sub = D-Sub 1.5m length or D-Sub = D-Sub 1.8m length

Following is the worst condition:

A) Continuous Operating (Resolution: 1280×1024 "H" Pattern)

Dot Clock Frequency : 135 MHz

Vertical Frequency : 75 Hz

Horizontal Frequency : 80kHz

Video I/F Cable : D-Sub = D-Sub 1.8m length

Frequency (MHz)	Polarity (H/V)	Receiver * Reading (dB μ V)	Correction Factor (dB/m)	Corrected Reading (dB μ V/m)	3 Meter Limit (dB μ V/m)
385.061	Horizontal	52.9	-11.0	41.9	46.0
54.961	Vertical	49.8	-23.0	26.8	40.0
165.054	Vertical	45.7	-18.2	27.5	43.5
220.092	Vertical	48.5	-18.5	30.0	46.0
269.988	Vertical	49.6	-14.3	35.3	46.0
330.011	Vertical	46.8	-12.5	34.3	46.0

*All readings are quasi-peak unless stated otherwise, with an IF bandwidth of 120 kHz, along with an 1 S sweep time. A video filter was not used.

Uncertainty of measurement result: ± 3.234 dB

Environment:

Temperature 28 $^{\circ}$ C

Humidity 54 %

Tested Personnel:

Tester Signature Kouhei Hasegawa

Typed/Printed Name Kouhei Hasegawa

8. List of Test and Measurement Instruments**Conducted Emission**

Manufacturer	Instruments	Model / Type	Serial No.	Calibration Date Next Calibration
ROHDE & SCHWARZ	Spectrum Analyzer	FSB / DISPLAY	838497/005 / 838301/009	May, 1999 May, 2000
ROHDE & SCHWARZ	EMI Test Receiver	ESHS10	842121/012	May, 1999 May, 2000
ROHDE & SCHWARZ	Artificial-Mains Network	ESH2-Z5	842210/010	May, 1999 May, 2000
CHASE ELECTRONICS LIMITED	Artificial-Mains Network	MN2050B	1140	May, 1999 May, 2000

Radiated Emission

Manufacturer	Instruments	Model / Type	Serial No.	Calibration Date Next Calibration
ROHDE & SCHWARZ	Spectrum Analyzer	FSB / DISPLAY	838497/005 / 838301/009	May, 1999 May, 2000
ROHDE & SCHWARZ	EMI Test Receiver	ESVS10	842122/014	May, 1999 May, 2000
CHASE ELECTRONICS LIMITED	Pre-Amplifier	CPA9231	3045	February, 1999 February, 2000
CHASE ELECTRONICS LIMITED	Biconical Logperiodic Antenna	CBL6111A	1732	June 1998 June 1999