

# TEST REPORT

of

FCC Part 15 Subpart B&amp;C §15.247 / RSS-210 Issue 8, RSS-Gen Issue 3

FCC ID/IC Certification: A3LWB850F / 649E-WB850F

Equipment Under Test : Digital Camera  
Model Name : WB850F  
Serial No. : N/A  
Applicant : SAMSUNG ELECTRONICS Co., Ltd.  
Manufacturer : SAMSUNG ELECTRONICS Co., Ltd.  
Manufacturer's factory : TIANJIN SAMSUNG OPTO-ELECTRONICS CO., LTD.  
Date of Test(s) : 2012.02.07 ~ 2012.02.15  
Date of Issue : 2012.02.15

In the configuration tested, the EUT complied with the standards specified above.

Tested By:



Date

2012.02.15

Duke Ko

Approved By:



Date

2012.02.15

Feel Jeong

*The results shown in this test report refer only to the sample(s) tested unless otherwise stated. This test report cannot be reproduced, except in full, without prior written permission of the Company.*

SGS Korea Co., Ltd. (Gunpo Laboratory) 18-34, Sanbon-dong, Gunpo-si, Gyeonggi-do, Korea, 435-040

Tel. +82 31 428 5700 / Fax. +82 31 427 2371

[www.ee.sgs.com/korea](http://www.ee.sgs.com/korea)

---

# INDEX

## Table of contents

1. General information -----	3
2. Transmitter radiated spurious emissions and conducted spurious emission -----	6
3. Receiver Radiated Spurious Emission -----	25
4. 6 dB bandwidth -----	27
5. Maximum peak output power -----	39
6. Power Spectral Density -----	41
7. Transmitter AC Power Line Conducted Emission-----	48
8. Receiver AC Power Line Conducted Emission -----	53
9. Antenna Requirement -----	57
10. RF Exposure evaluation-----	58

---

*The results shown in this test report refer only to the sample(s) tested unless otherwise stated. This test report cannot be reproduced, except in full, without prior written permission of the Company.*

## 1. General Information

### 1.1. Testing Laboratory

SGS Korea Co., Ltd.  
 - Wireless Div. 2FL, 18-34, Sanbon-dong, Gunpo-si, Gyeonggi-dong, Korea  
 - 705, Dongcheon-dong Suji-gu, Yongin-si, Gyeonggi-do, Korea  
[www.ee.sgs.com/korea](http://www.ee.sgs.com/korea)  
 Telephone : +82 +31 428 5700  
 FAX : +82 +31 427 2371

### 1.2. Details of Applicant

Applicant : SAMSUNG ELECTRONICS Co., Ltd.  
 Address : 416, Maetan-dong, Yeongtong-gu, Suwon-si, Gyeonggi-do, Korea  
 Contact Person : Lee, Mi Hyeon  
 Phone No. : +82 +31 277 6803

### 1.3. Details of Factory Information

Factory : TIANJIN SAMSUNG OPTO-ELECTRONICS CO., LTD.  
 Address : No.9 ZhangHeng Street, Micro-Electronic Industrial Park, JinGang Road, Tianjin, China

### 1.4. Description of EUT

<b>Kind of Product</b>	Digital Camera
<b>Model Name</b>	WB850F
<b>Serial Number</b>	N / A
<b>Power Supply</b>	DC 3.7 V (Li-ion Battery)
<b>Frequency Range</b>	2 412 ~ 2 462 MHz (802.11b/g/n-HT20_SISO)
<b>Modulation Technique</b>	DSSS, OFDM
<b>Number of Channels</b>	11
<b>Antenna Type</b>	Integral Type
<b>Antenna Gain</b>	1.5 dBi
<b>H/W version</b>	WB850_PV1
<b>S/W version</b>	G202070

### 1.5. Declaration by the manufacturer

- 802.11n supports HT20 mode only.

*The results shown in this test report refer only to the sample(s) tested unless otherwise stated. This test report cannot be reproduced, except in full, without prior written permission of the Company.*

SGS Korea Co., Ltd. (Gunpo Laboratory) 18-34, Sanbon-dong, Gunpo-si, Gyeonggi-do, Korea, 435-040

Tel. +82 31 428 5700 / Fax. +82 31 427 2371

[www.ee.sgs.com/korea](http://www.ee.sgs.com/korea)

### 1.6. Test Equipment List

Equipment	Manufacturer	Model	S/N	Cal Due.
Signal Generator	R & S	SMR40	100272	Jul. 15, 2012
Spectrum Analyzer	Agilent	E4440A	MY43362142	May 18, 2012
Power Divider	Agilent	11636B	54906	Mar. 30, 2012
Power Sensor	R&S	NRP-Z81	100669	Apr. 04, 2012
High Pass Filter	Wainwright	WHK3.0/18G-10SS	344	Jul. 07, 2012
DC Power Supply	Agilent	6553A	MY40000695	Jul. 04, 2012
Preamplifier	H.P.	8447F	2944A03909	Jul. 04, 2012
Preamplifier	R & S	SCU 18	10117	Mar. 23, 2012
Test Receiver	R & S	ESU26	100109	Feb. 21, 2012
Two-Line V-Network	R & S	ENV216	100190	Jan. 09, 2013
Test Receiver	R & S	ESHS10	863365/018	Apr. 27, 2012
Bilog Antenna	SCHWARZBECK MESSELEKTRONIK	VULB9163	396	Apr. 27, 2013
Horn Antenna	R & S	HF 907	100019	Jul. 29, 2012
Horn Antenna	SCHWARZBECK	BBH 9120D	BBHA9170431	Mar. 17, 2012
Antenna Master	EMCO	1050	N.C.R.	N.C.R.
Turn Table	Daeil EMC	DI-1500	N.C.R.	N.C.R.
Anechoic Chamber	SY Corporation	L x W x H (6.5 m x 3.5 m x 3.5 m)	N.C.R.	N.C.R.
Anechoic Chamber	SY Corporation	L x W x H (9.6 m x 6.4 m x 6.6 m)	N.C.R.	N.C.R.

*The results shown in this test report refer only to the sample(s) tested unless otherwise stated. This test report cannot be reproduced, except in full, without prior written permission of the Company.*

### 1.7. Summary of Test Results

The EUT has been tested according to the following specifications:

APPLIED STANDARD:FCC Part15 subpart B&C, RSS-210, RSS-Gen			
Standard section		Test Item	Result
15.205(a) 15.209 15.247(d)	A8.5	Transmitter Radiated Spurious Emissions Conducted Spurious Emission	Complied
15.109(a)	RSS-Gen 6	Receiver Radiated Spurious Emission	Complied
15.247(a)(2)	A8.2(a)	6 dB Bandwidth and 99% BW	Complied
15.247(b)(3)	A8.4(4)	Maximum Peak Output Power	Complied
15.247(e)	A8.3(2)	Power Spectral Density	Complied
15.207	RSS-Gen 7.2.4	Transmitter AC Power Line Conducted Emission	Complied
15.107	RSS-Gen 7.2.4	Receiver AC Power Line Conducted Emission	Complied
15.247(i) 1.1307(b)(1)	RSS-Gen 5.5/ RSS-102	Maximum Permissible Exposure (Exposure of Humans to RF Fields)	Complied

### 1.8. Conclusion of worst-case

The field strength of spurious emission was measured in three orthogonal EUT positions(X-axis, Y-axis and Z-axis). Worst case is X-axis. 1 Mbps is the highest output power in the 11b. 6 Mbps is the highest output power in the 11g. In case of 11n, we chose MCS0 mode.

### 1.9. Test report revision

Revision	Report number	Description
0	F690501/RF-RTL005330	Initial

*The results shown in this test report refer only to the sample(s) tested unless otherwise stated. This test report cannot be reproduced, except in full, without prior written permission of the Company.*

## 2. Transmitter Radiated Spurious Emissions and Conducted Spurious Emission

### 2.1. Test Setup

#### 2.1.1. Transmitter Radiated Spurious Emissions

The diagram below shows the test setup that is utilized to make the measurements for emission from 30 MHz to 1 GHz Emissions.

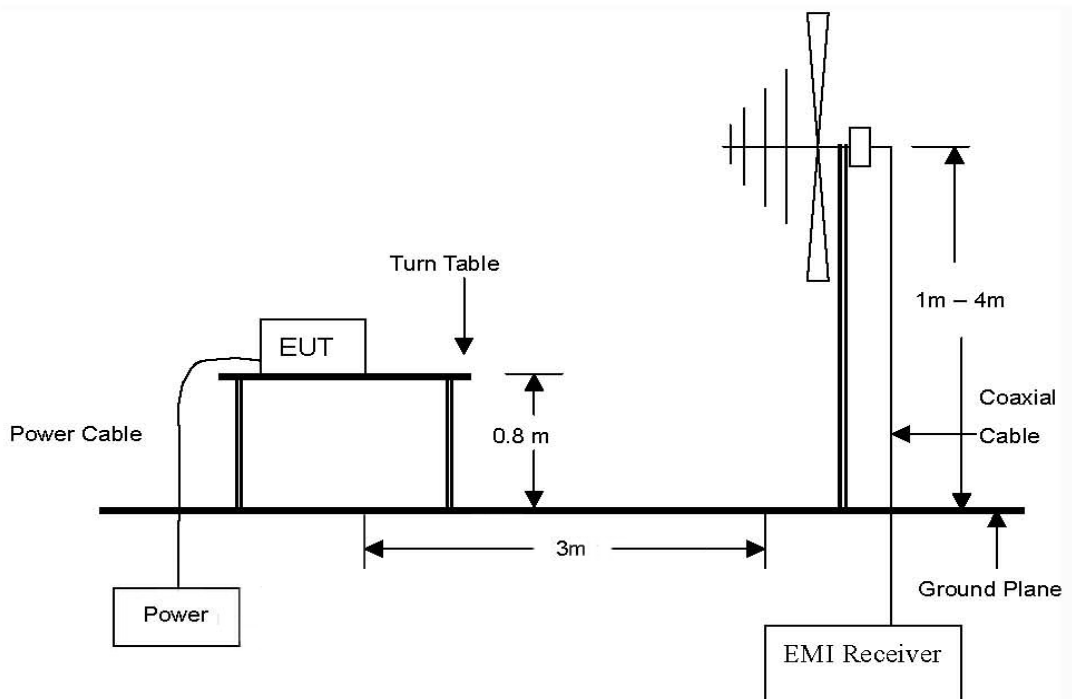

The diagram below shows the test setup that is utilized to make the measurements for emission from 1 GHz to 24 GHz Emissions.

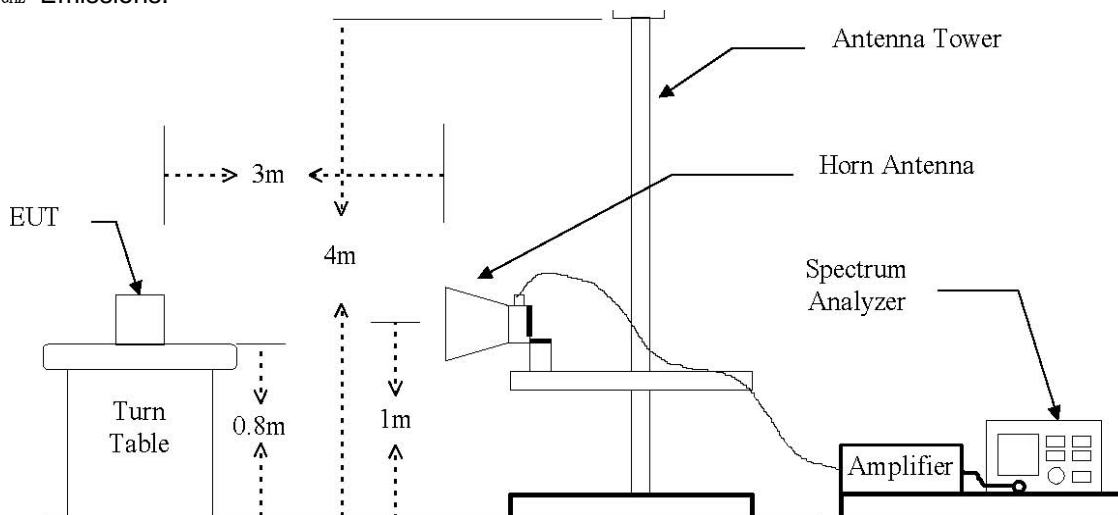

*The results shown in this test report refer only to the sample(s) tested unless otherwise stated. This test report cannot be reproduced, except in full, without prior written permission of the Company.*

### 2.1.2. Conducted Spurious Emission

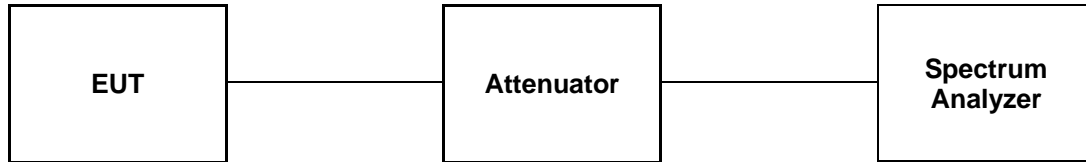

### 2.2. Limit

According to §15.247(d), in any 100 kHz bandwidth outside the frequency band in which the spread spectrum or digitally modulated intentional radiator is operating, the radio frequency power that is produced by the intentional radiator shall be at least 20 dB below that in the 100 kHz bandwidth within the band that contains the highest level of the desired power, based on either an RF conducted or a radiated measurement, provided the transmitter demonstrates compliance with the peak conducted power limits. If the transmitter complies with the conducted power limits based on the use of RMS averaging over a time interval, as permitted under paragraph(b)(3) of this section, the attenuation required under this paragraph shall be 30 dB instead of 20 dB. Attenuation below the general limits specified in section §15.209(a) is not required. In addition, radiated emission which in the restricted band, as define in section §15.205(a), must also comply the radiated emission limits specified in section §15.209(a) (see section §15.205(c))

According to § 15.209(a), Except as provided elsewhere in this Subpart, the emissions from an intentional radiator shall not exceed the field strength levels specified in the following table :

Frequency (MHz)	Distance (Meters)	Field Strength (dB $\mu$ V/m)	Field Strength ( $\mu$ V/m)
30 - 88	3	40.0	100
88 – 216	3	43.5	150
216 – 960	3	46.0	200
Above 960	3	54.0	500

*The results shown in this test report refer only to the sample(s) tested unless otherwise stated. This test report cannot be reproduced, except in full, without prior written permission of the Company.*

## 2.3. Test Procedures

Radiated emissions from the EUT were measured according to the dictates of ANSI C63.4:2003

### 2.3.1. Test Procedures for Radiated Spurious Emissions

1. The EUT was placed on the top of a rotating table 0.8 meters above the ground at a 3 meter anechoic chamber test site. The table was rotated 360 degrees to determine the position of the highest radiation.
2. During performing radiated emission below 1 GHz, the EUT was set 3 meters away from the interference receiving antenna, which was mounted on the top of a variable-height antenna tower. During performing radiated emission above 1 GHz, the EUT was set 3 meter away from the interference-receiving antenna.
3. The antenna is a broadband antenna, and its height is varied from one meter to four meters above the ground to determine the maximum value of the field strength. Both horizontal and vertical polarizations of the antenna are set to make the measurement.
4. For each suspected emission, the EUT was arranged to its worst case and then the antenna was tuned to heights from 1 meter to 4 meters and the table was turned from 0 degrees to 360 degrees to find the maximum reading.
5. The test-receiver system was set to Peak Detect Function and Specified Bandwidth with Maximum Hold Mode.
6. If the emission level of the EUT in peak mode was 10 dB lower than the limit specified, then testing could be stopped and the peak values of the EUT would be reported. Otherwise the emissions that did not have 10 dB margin would be re-tested one by one using peak, quasi-peak or average method as specified and then reported in a data sheet.

#### NOTE ;

1. The resolution bandwidth and video bandwidth of test receiver/spectrum analyzer is 120 kHz for Peak detection (PK) or Quasi-peak detection (QP) at frequency below 1 GHz.
2. The resolution bandwidth and video bandwidth of test receiver/spectrum analyzer is 1 MHz for Peak detection and frequency above 1 GHz.
3. The resolution bandwidth of test receiver/spectrum analyzer is 1 MHz and the video bandwidth is 10 Hz for Average detection (AV) at frequency above 1 GHz.

### 2.3.2. Test Procedures for Conducted Spurious Emissions

1. The transmitter output was connected to the spectrum analyzer.
2. The bandwidth of the fundamental frequency was measured with the spectrum analyzer using RBW = 100 kHz, VBW = 100 kHz.

---

*The results shown in this test report refer only to the sample(s) tested unless otherwise stated. This test report cannot be reproduced, except in full, without prior written permission of the Company.*

## 2.4. Test Results

Ambient temperature : (24 ± 2) °C  
 Relative humidity : 47 % R.H.

### 2.4.1. Spurious Radiated Emission (Worst case configuration\_11b mode)

The frequency spectrum from 30 MHz to 1 000 MHz was investigated. Emission levels are not reported much lower than the limits by over 30 dB. All reading values are peak values.

Radiated Emissions			Ant	Correction Factors		Total	FCC Limit	
Frequency (MHz)	Reading (dBμV)	Detect Mode	Pol.	AF (dB/m)	AMP + CL (dB)	Actual (dBμV/m)	Limit (dBμV/m)	Margin (dB)
127.85	40.3	Peak	H	8.9	-25.7	23.5	43.5	20.0
349.94	40.1	Peak	H	13.2	-25.1	28.2	46.0	17.8
399.93	41.4	Peak	H	13.7	-24.5	30.6	46.0	15.4
449.97	36.7	Peak	H	14.8	-24.3	27.2	46.0	18.8
537.27	36.0	Peak	H	16.6	-24.5	28.1	46.0	17.9
Above 600.00	Not detected	-	-	-	-	-	-	-

#### Remark:

1. All spurious emission at channels are almost the same below 1 GHz, so that the channel was chosen at representative in final test.
2. Actual = Reading + AF + AMP + CL

*The results shown in this test report refer only to the sample(s) tested unless otherwise stated. This test report cannot be reproduced, except in full, without prior written permission of the Company.*

### 2.4.2. Spurious Radiated Emission

The frequency spectrum above 1000 MHz was investigated. Emission levels are not reported much lower than the limits by over 30 dB.

#### DSSS : 802.11b

Low Channel (2 412 MHz)

Radiated Emissions			Ant	Correction Factors		Total	FCC Limit	
Frequency (MHz)	Reading (dB $\mu$ V)	Detect Mode	Pol.	AF (dB/m)	CL (dB)	Actual (dB $\mu$ V/m)	Limit (dB $\mu$ V/m)	Margin (dB)
*2 390.00	25.19	Peak	H	28.05	5.23	58.47	74.00	15.53
*2 390.00	14.36	Average	H	28.05	5.23	47.64	54.00	6.36

Radiated Emissions			Ant	Correction Factors		Total	FCC Limit	
Frequency (MHz)	Reading (dB $\mu$ V)	Detect Mode	Pol.	AF (dB/m)	AMP+CL (dB)	Actual (dB $\mu$ V/m)	Limit (dB $\mu$ V/m)	Margin (dB)
4 823.93	41.92	Peak	H	32.30	-34.55	39.67	74.00	34.33
Above 4 900.00	Not detected	-	-	-	-	-	-	-

Middle Channel (2 437 MHz)

Radiated Emissions			Ant	Correction Factors		Total	FCC Limit	
Frequency (MHz)	Reading (dB $\mu$ V)	Detect Mode	Pol.	AF (dB/m)	AMP+CL (dB)	Actual (dB $\mu$ V/m)	Limit (dB $\mu$ V/m)	Margin (dB)
4 874.22	42.71	Peak	H	32.79	-34.53	40.97	74.00	33.03
Above 4 900.00	Not detected	-	-	-	-	-	-	-

The results shown in this test report refer only to the sample(s) tested unless otherwise stated. This test report cannot be reproduced, except in full, without prior written permission of the Company.

High Channel (2 462 MHz)

Radiated Emissions			Ant	Correction Factors		Total	FCC Limit	
Frequency (MHz)	Reading (dB $\mu$ V)	Detect Mode	Pol.	AF (dB/m)	CL (dB)	Actual (dB $\mu$ V/m)	Limit (dB $\mu$ V/m)	Margin (dB)
*2 483.50	27.73	Peak	H	28.31	5.37	61.41	74.00	12.59
*2 483.50	14.34	Average	H	28.31	5.37	48.02	54.00	5.98

Radiated Emissions			Ant	Correction Factors		Total	FCC Limit	
Frequency (MHz)	Reading (dB $\mu$ V)	Detect Mode	Pol.	AF (dB/m)	AMP+CL (dB)	Actual (dB $\mu$ V/m)	Limit (dB $\mu$ V/m)	Margin (dB)
4 923.97	42.68	Peak	H	33.10	-34.24	41.54	74.00	32.46
Above 5 000.00	Not detected	-	-	-	-	-	-	-

The results shown in this test report refer only to the sample(s) tested unless otherwise stated. This test report cannot be reproduced, except in full, without prior written permission of the Company.

**OFDM : 802.11g**

Low Channel (2 412 MHz)

Radiated Emissions			Ant	Correction Factors		Total	FCC Limit	
Frequency (MHz)	Reading (dB $\mu$ V)	Detect Mode	Pol.	AF (dB/m)	CL (dB)	Actual (dB $\mu$ V/m)	Limit (dB $\mu$ V/m)	Margin (dB)
*2 390.00	26.40	Peak	H	28.05	5.23	59.68	74.00	14.32
*2 390.00	14.77	Average	H	28.05	5.23	48.05	54.00	5.95

Radiated Emissions			Ant	Correction Factors		Total	FCC Limit	
Frequency (MHz)	Reading (dB $\mu$ V)	Detect Mode	Pol.	AF (dB/m)	AMP+CL (dB)	Actual (dB $\mu$ V/m)	Limit (dB $\mu$ V/m)	Margin (dB)
4 824.51	37.00	Peak	H	32.31	-34.55	34.76	74.00	39.24
Above 4 900.00	Not detected	-	-	-	-	-	-	-

Middle Channel (2 437 MHz)

Radiated Emissions			Ant	Correction Factors		Total	FCC Limit	
Frequency (MHz)	Reading (dB $\mu$ V)	Detect Mode	Pol.	AF (dB/m)	AMP+CL (dB)	Actual (dB $\mu$ V/m)	Limit (dB $\mu$ V/m)	Margin (dB)
4 875.23	37.18	Peak	H	32.80	-34.52	35.46	74.00	38.54
Above 4 900.00	Not detected	-	-	-	-	-	-	-

The results shown in this test report refer only to the sample(s) tested unless otherwise stated. This test report cannot be reproduced, except in full, without prior written permission of the Company.

High Channel (2 462 MHz)

Radiated Emissions			Ant	Correction Factors		Total	FCC Limit	
Frequency (MHz)	Reading (dB $\mu$ V)	Detect Mode	Pol.	AF (dB/m)	CL (dB)	Actual (dB $\mu$ V/m)	Limit (dB $\mu$ V/m)	Margin (dB)
*2 483.50	31.73	Peak	H	28.31	5.37	65.41	74.00	8.59
*2 483.50	17.02	Average	H	28.31	5.37	50.70	54.00	3.30

Radiated Emissions			Ant	Correction Factors		Total	FCC Limit	
Frequency (MHz)	Reading (dB $\mu$ V)	Detect Mode	Pol.	AF (dB/m)	AMP+CL (dB)	Actual (dB $\mu$ V/m)	Limit (dB $\mu$ V/m)	Margin (dB)
4 921.32	37.63	Peak	H	33.08	-34.25	36.46	74.00	37.54
Above 5 000.00	Not detected	-	-	-	-	-	-	-

The results shown in this test report refer only to the sample(s) tested unless otherwise stated. This test report cannot be reproduced, except in full, without prior written permission of the Company.

**OFDM : 802.11n**

Low Channel (2 412 MHz)

Radiated Emissions			Ant	Correction Factors		Total	FCC Limit	
Frequency (MHz)	Reading (dB $\mu$ V)	Detect Mode	Pol.	AF (dB/m)	CL (dB)	Actual (dB $\mu$ V/m)	Limit (dB $\mu$ V/m)	Margin (dB)
*2 390.00	25.49	Peak	H	28.05	5.23	58.77	74.00	15.23
*2 390.00	14.59	Average	H	28.05	5.23	47.87	54.00	6.13

Radiated Emissions			Ant	Correction Factors		Total	FCC Limit	
Frequency (MHz)	Reading (dB $\mu$ V)	Detect Mode	Pol.	AF (dB/m)	AMP+CL (dB)	Actual (dB $\mu$ V/m)	Limit (dB $\mu$ V/m)	Margin (dB)
4 823.78	38.28	Peak	H	32.30	-34.55	36.03	74.00	37.97
Above 4 900.00	Not detected	-	-	-	-	-	-	-

Middle Channel (2 437 MHz)

Radiated Emissions			Ant	Correction Factors		Total	FCC Limit	
Frequency (MHz)	Reading (dB $\mu$ V)	Detect Mode	Pol.	AF (dB/m)	AMP+CL (dB)	Actual (dB $\mu$ V/m)	Limit (dB $\mu$ V/m)	Margin (dB)
4 872.48	37.04	Peak	H	32.78	-34.54	35.28	74.00	38.72
Above 4 900.00	Not detected	-	-	-	-	-	-	-

The results shown in this test report refer only to the sample(s) tested unless otherwise stated. This test report cannot be reproduced, except in full, without prior written permission of the Company.

High Channel (2 462 MHz)

Radiated Emissions			Ant	Correction Factors		Total	FCC Limit	
Frequency (MHz)	Reading (dB $\mu$ V)	Detect Mode	Pol.	AF (dB/m)	CL (dB)	Actual (dB $\mu$ V/m)	Limit (dB $\mu$ V/m)	Margin (dB)
*2 483.50	26.14	Peak	H	28.31	5.37	59.82	74.00	14.18
*2 483.50	14.74	Average	H	28.31	5.37	48.42	54.00	5.58

Radiated Emissions			Ant	Correction Factors		Total	FCC Limit	
Frequency (MHz)	Reading (dB $\mu$ V)	Detect Mode	Pol.	AF (dB/m)	AMP+CL (dB)	Actual (dB $\mu$ V/m)	Limit (dB $\mu$ V/m)	Margin (dB)
4 924.15	37.36	Peak	H	33.11	-34.24	36.23	74.00	37.77
Above 5 000.00	Not detected	-	-	-	-	-	-	-

■ Remarks

1. "\*" means the restricted band.
2. Measuring frequencies from 1 GHz to the 10<sup>th</sup> harmonic of highest fundamental Frequency.
3. Radiated emissions measured in frequency above 1 000 MHz were made with an instrument using peak/average detector mode.
4. Average test would be performed if the peak result were greater than the average limit.
5. Actual = Reading + AF + AMP + CL
6. To get a maximum emission level from the EUT, the EUT was moved throughout the x-axis, y-axis and z-axis. The worst case is z-axis.

*The results shown in this test report refer only to the sample(s) tested unless otherwise stated. This test report cannot be reproduced, except in full, without prior written permission of the Company.*

### 2.4.3. Spurious RF Conducted Emissions: Plot of Spurious RF Conducted Emission

DSSS : 802.11b

Low Channel

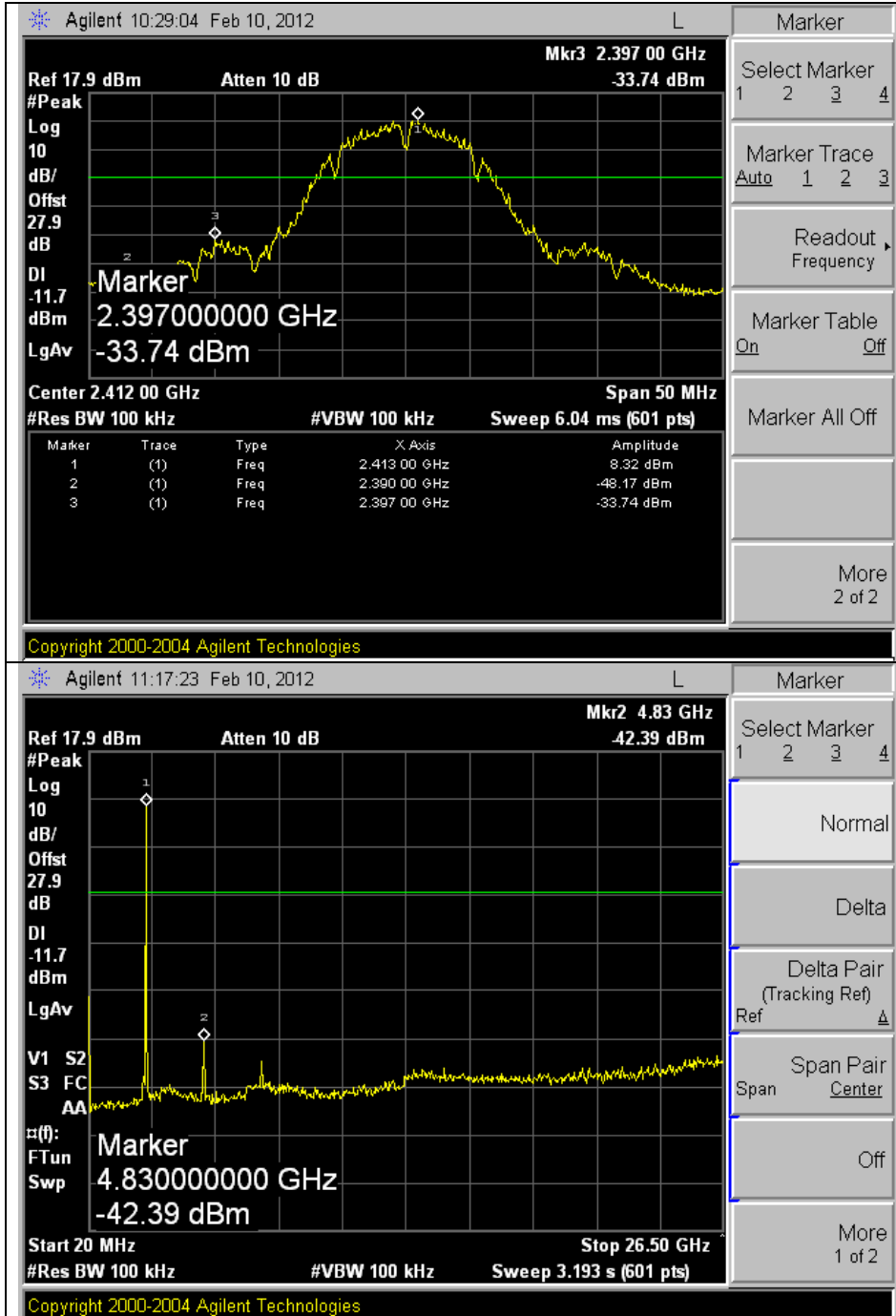

The results shown in this test report refer only to the sample(s) tested unless otherwise stated. This test report cannot be reproduced, except in full, without prior written permission of the Company.

Middle Channel

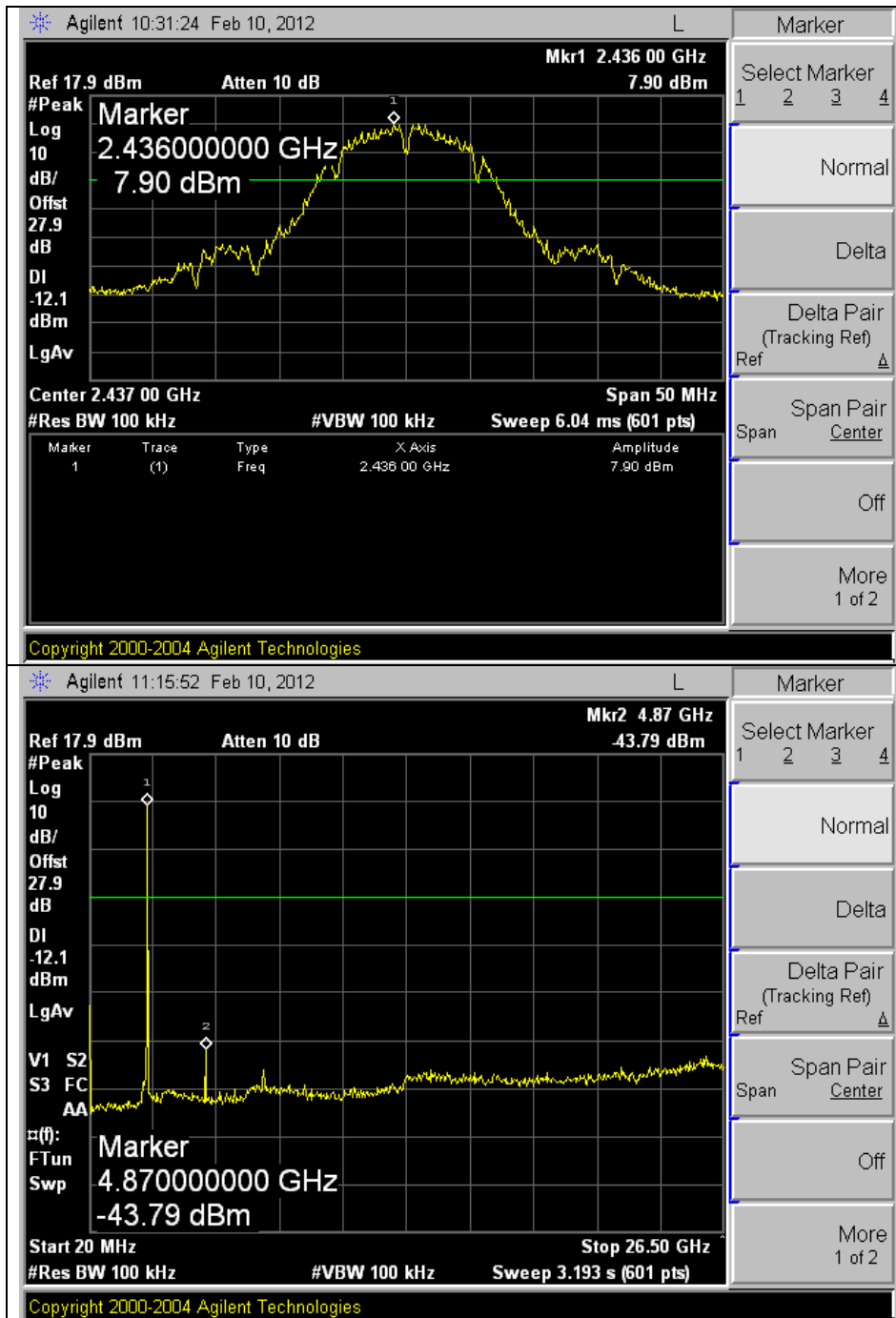

The results shown in this test report refer only to the sample(s) tested unless otherwise stated. This test report cannot be reproduced, except in full, without prior written permission of the Company.

High Channel



The results shown in this test report refer only to the sample(s) tested unless otherwise stated. This test report cannot be reproduced, except in full, without prior written permission of the Company.

**OFDM : 802.11g**  
Low Channel

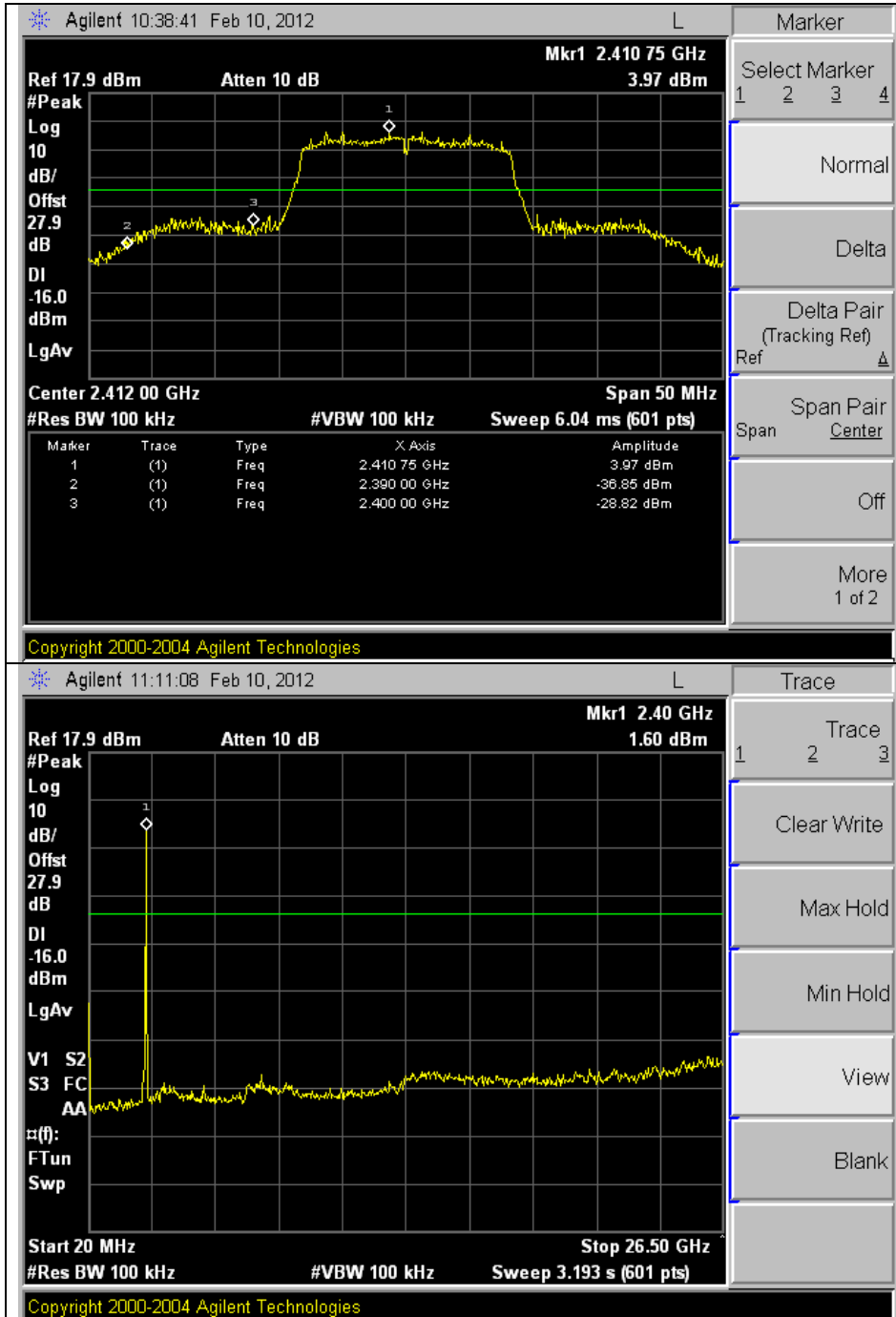

The results shown in this test report refer only to the sample(s) tested unless otherwise stated. This test report cannot be reproduced, except in full, without prior written permission of the Company.

Middle Channel

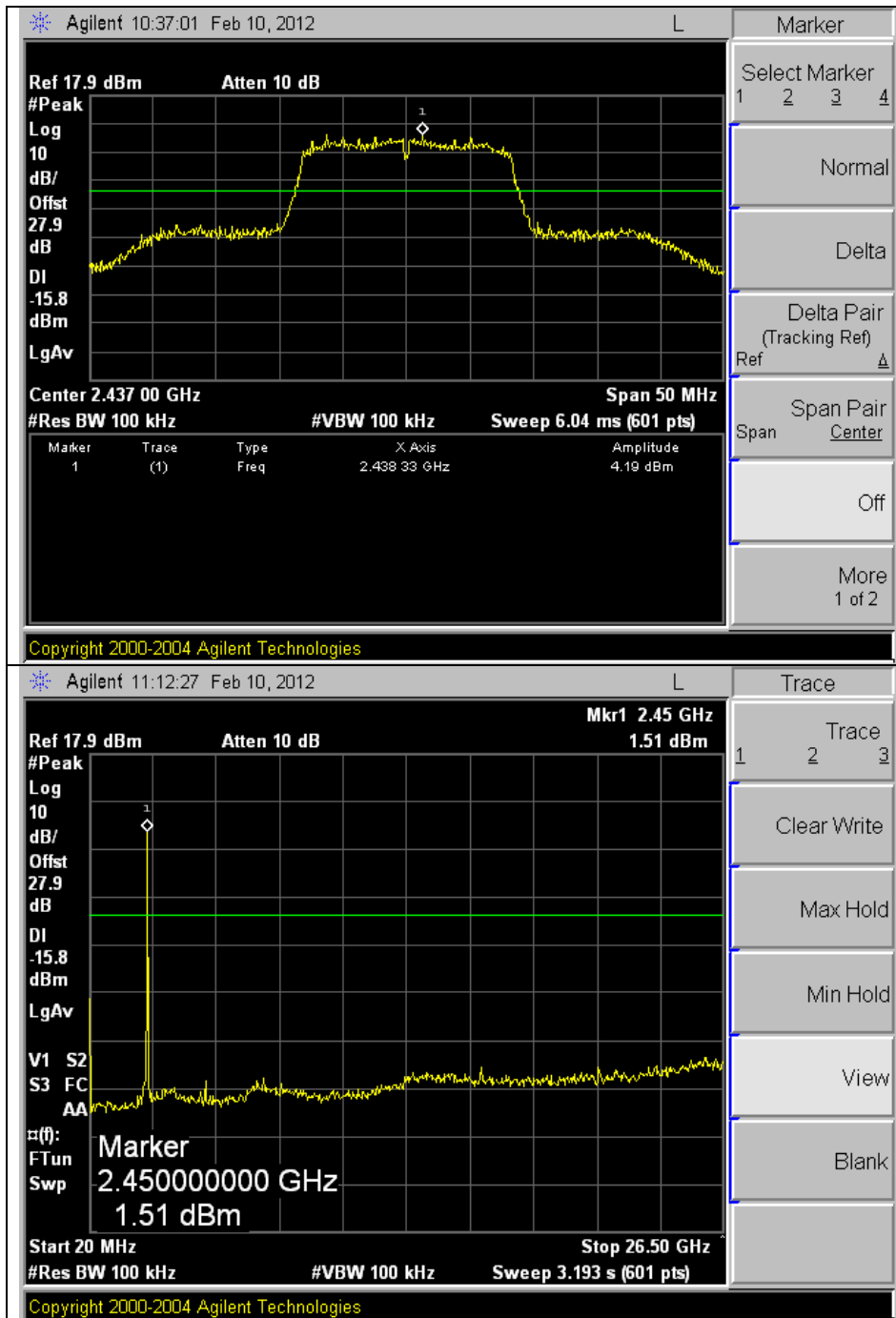

The results shown in this test report refer only to the sample(s) tested unless otherwise stated. This test report cannot be reproduced, except in full, without prior written permission of the Company.

High Channel

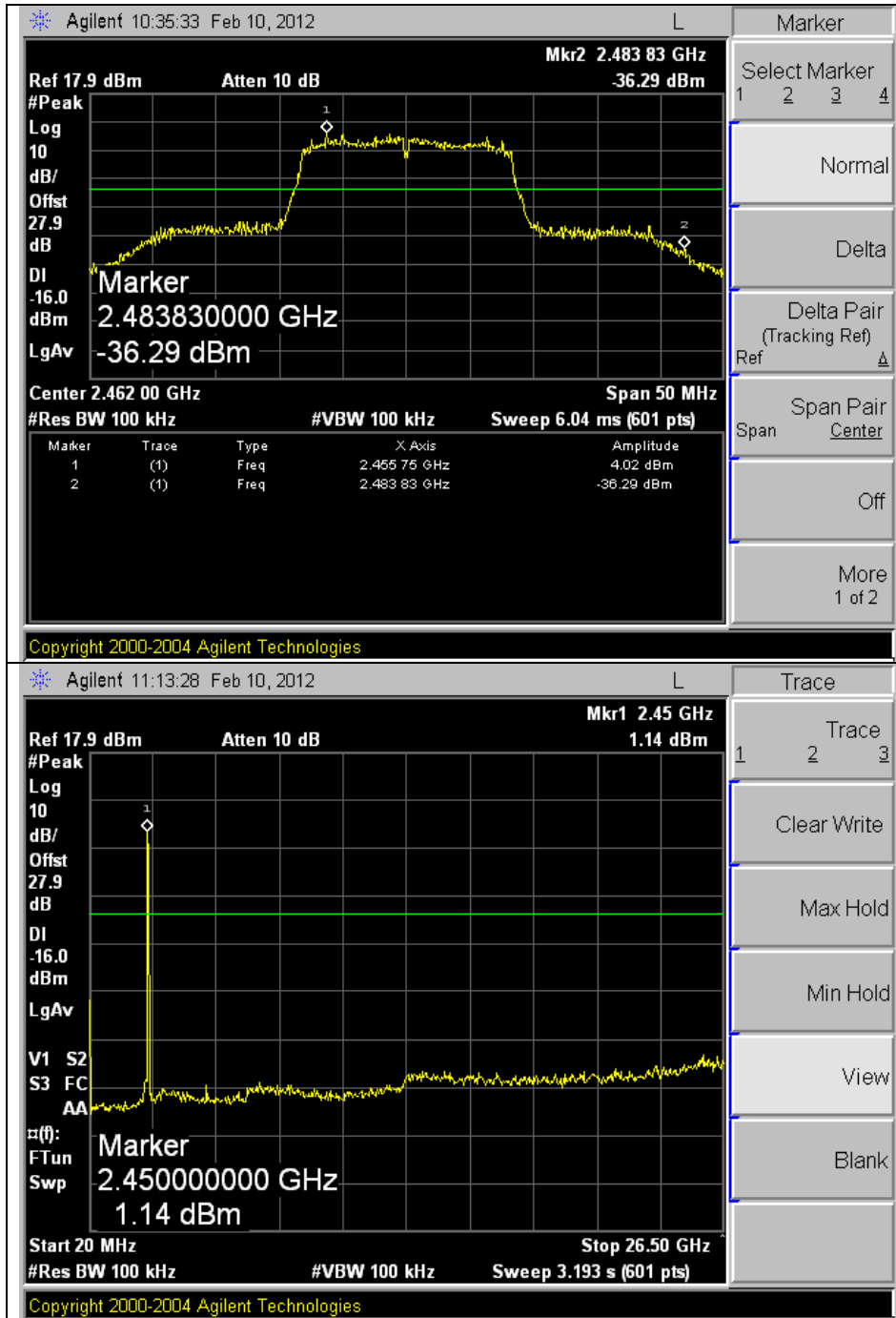

The results shown in this test report refer only to the sample(s) tested unless otherwise stated. This test report cannot be reproduced, except in full, without prior written permission of the Company.

**OFDM : 802.11n**  
Low Channel

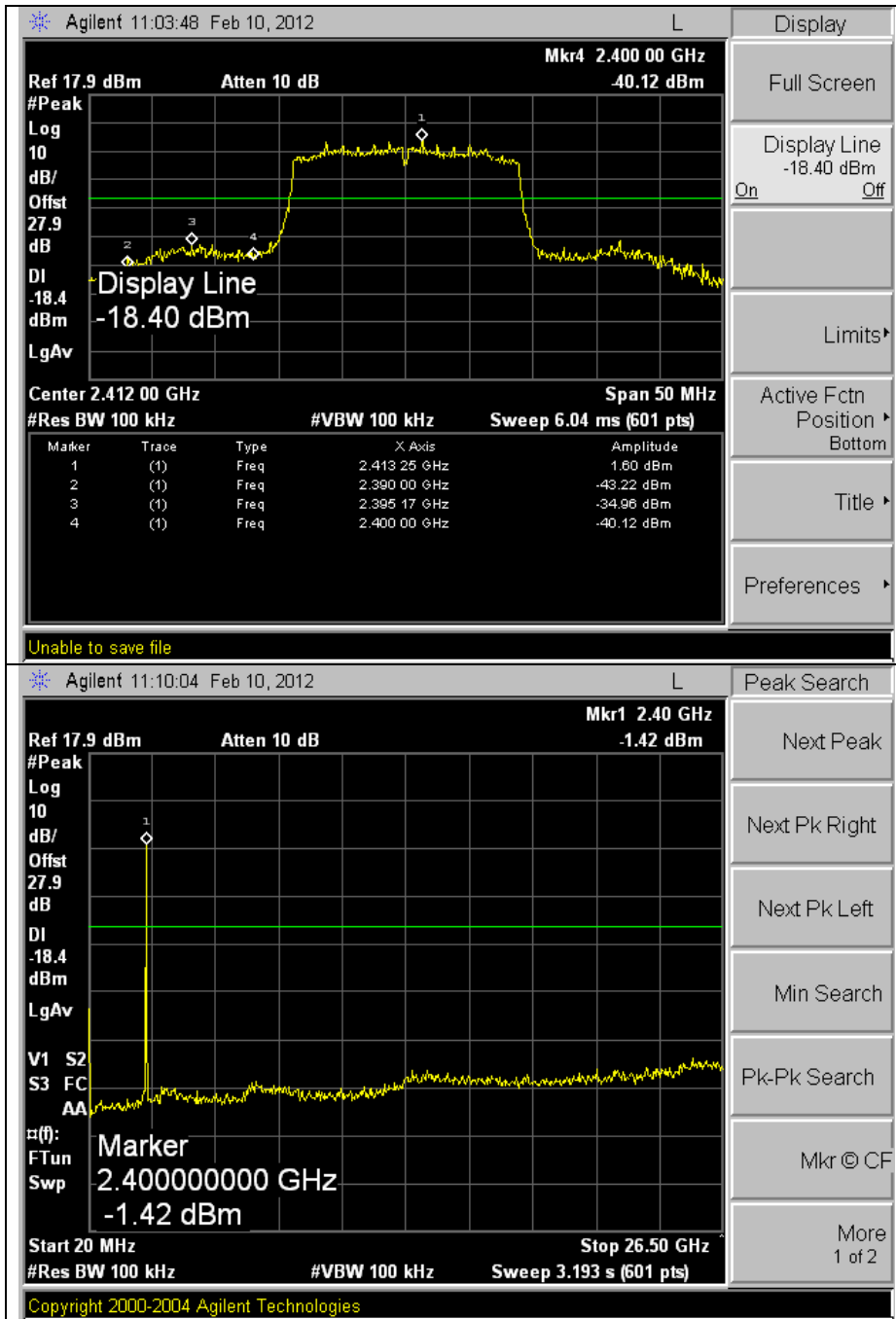

The results shown in this test report refer only to the sample(s) tested unless otherwise stated. This test report cannot be reproduced, except in full, without prior written permission of the Company.

Middle Channel

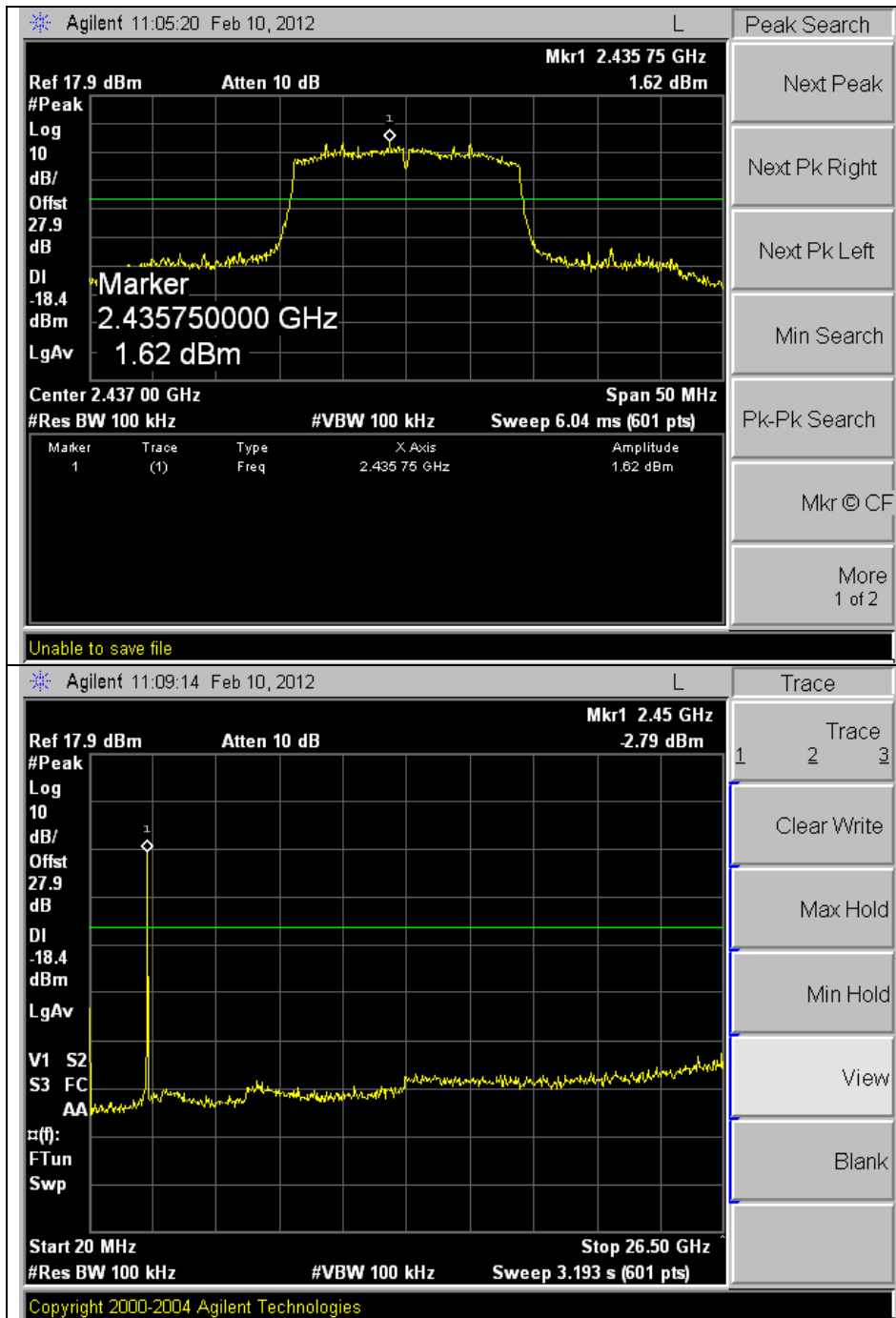

The results shown in this test report refer only to the sample(s) tested unless otherwise stated. This test report cannot be reproduced, except in full, without prior written permission of the Company.

High Channel

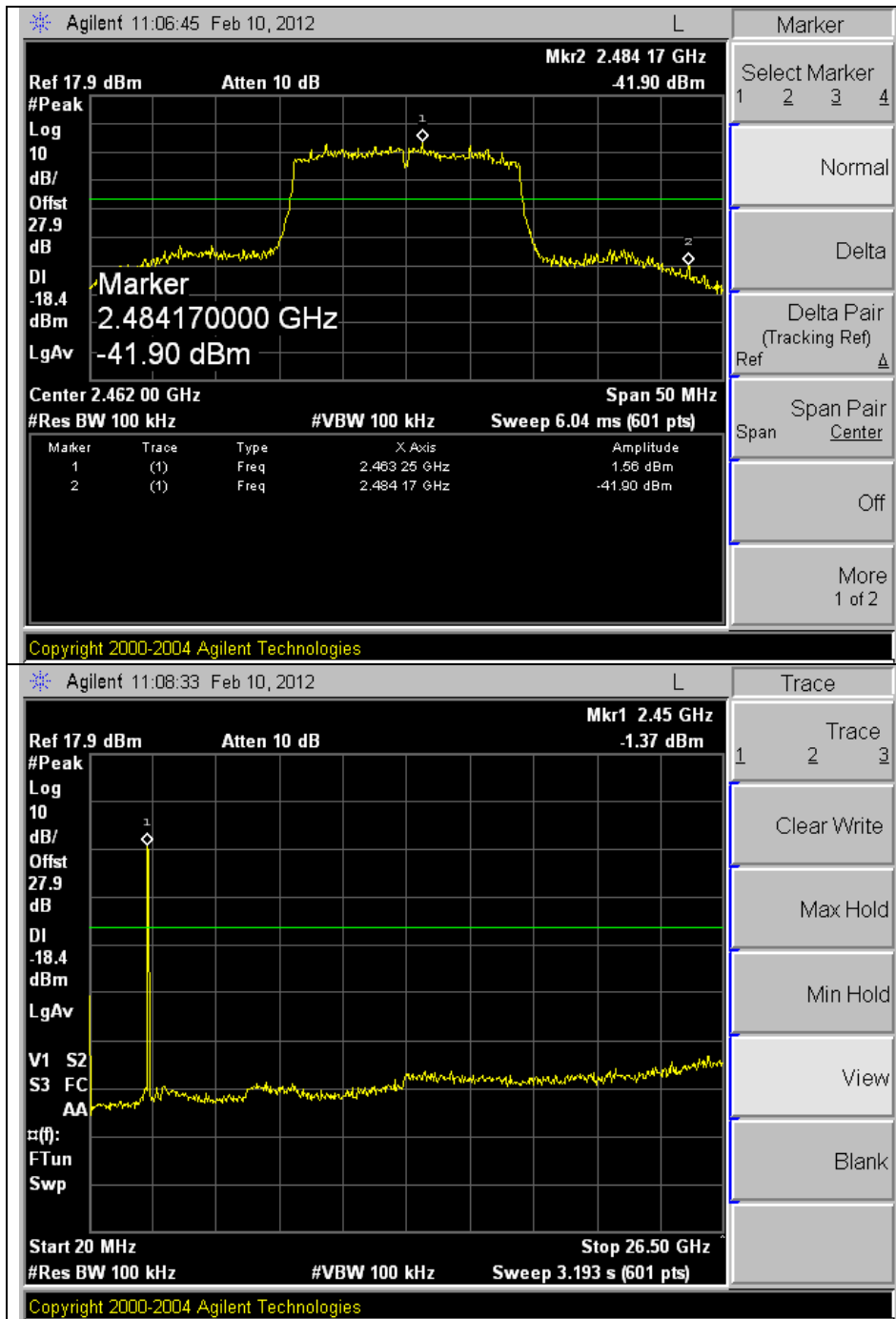

The results shown in this test report refer only to the sample(s) tested unless otherwise stated. This test report cannot be reproduced, except in full, without prior written permission of the Company.

### 3. Receiver Radiated spurious emissions

#### 3.1. Test setup - Same as clause 2.1.

##### 3.1.1. Receiver Radiated Spurious Emissions - Same as clause 2.1.1.

#### 3.2. Limit

According to §15.109(a), Except for Class A digital devices, the field strength of radiated emission from unintentional radiator at a distance of 3 m shall not exceed the following values:

Frequency (MHz)	Distance (Meters)	Radiated (dB $\mu$ V/m)	Radiated ( $\mu$ V/m)
30 - 88	3	40.0	100
88 – 216	3	43.5	150
216 – 960	3	46.0	200
Above 960	3	54.0	500

#### 3.3. Test Procedures - Same as clause 2.3.

Radiated emissions from the EUT were measured according to the dictates of ANSI C63.4:2003

##### 3.3.1. Test Procedures for Radiated Spurious Emissions- Same as clause 2.3.1.

*The results shown in this test report refer only to the sample(s) tested unless otherwise stated. This test report cannot be reproduced, except in full, without prior written permission of the Company.*

### 3.4. Test Results

Ambient temperature : (24 ± 2) °C  
 Relative humidity : 47 % R.H.

#### 3.4.1. Spurious Radiated Emission (Worst case configuration\_11b mode)

The frequency spectrum from 30 MHz to 26.5 GHz was investigated. Emission levels are not reported much lower than the limits by over 30 dB. All reading values are peak values.

Radiated Emissions			Ant	Correction Factors		Total	FCC Limit	
Frequency (MHz)	Reading (dBμV)	Detect Mode	Pol.	AF (dB/m)	AMP + CL (dB)	Actual (dBμV/m)	Limit (dBμV/m)	Margin (dB)
349.94	40.7	Peak	H	13.2	-25.1	28.8	46.0	17.2
399.93	41.7	Peak	H	13.7	-24.5	30.9	46.0	15.1
449.93	37.7	Peak	H	14.8	-24.3	28.2	46.0	17.8
729.01	36.1	Peak	H	19.9	-23.9	32.1	46.0	13.9
Above 800.00	Not detected	-	-	-	-	-	-	-

#### Remark:

- All spurious emission at channels are almost the same from 30 MHz to 26.5 GHz, so that the middle channel was chosen at representative in final test.
- Actual = Reading + AF + AMP + CL

*The results shown in this test report refer only to the sample(s) tested unless otherwise stated. This test report cannot be reproduced, except in full, without prior written permission of the Company.*

## 4. 6 dB Bandwidth and 99 %Occupied Bandwidth Measurement

### 4.1. Test Setup

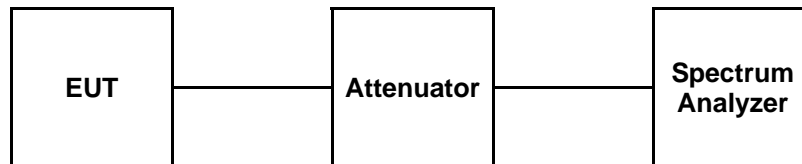

### 4.2. Limit

According to §15.247(a)(2), systems using digital modulation techniques may operate in the 902 ~928 MHz, 2 400 ~ 2 483.5 MHz, and 5 725 ~ 5 825 MHz bands. The minimum of 6 dB Bandwidth shall be at least 500 kHz

### 4.3. Test Procedure

1. The 6 dB band width was measured with a spectrum analyzer connected to RF antenna connector(conducted measurement) while EUT was operating in transmit mode at the appropriate center frequency. The analyzer center frequency was set to the EUT carrier frequency, using the analyzer. Display Line and Marker Delta functions, the 6 dB band width of the emission was determined.
2. The bandwidth of the fundamental frequency was measured with the spectrum analyzer using RBW = 100 kHz, VBW = 100 kHz, Span = 50 MHz.

*The results shown in this test report refer only to the sample(s) tested unless otherwise stated. This test report cannot be reproduced, except in full, without prior written permission of the Company.*

#### 4.4. Test Results

Ambient temperature : (24 ± 2) °C  
 Relative humidity : 47 % R.H.

Operation Mode	Channel	Channel Frequency (MHz)	6 dB Bandwidth (MHz)	99 % Bandwidth (MHz)
DSSS (802.11b)	Low	2 412	8.00	12.51
	Middle	2 437	8.58	12.61
	High	2 462	8.08	12.60
OFDM (802.11g)	Low	2 412	15.50	16.85
	Middle	2 437	16.00	16.85
	High	2 462	15.58	16.72
OFDM (802.11n)	Low	2 412	17.17	17.60
	Middle	2 437	16.92	17.58
	High	2 462	17.00	17.60

*The results shown in this test report refer only to the sample(s) tested unless otherwise stated. This test report cannot be reproduced, except in full, without prior written permission of the Company.*

**6 dB Bandwidth**

**DSSS : 802.11b**

Low Channel

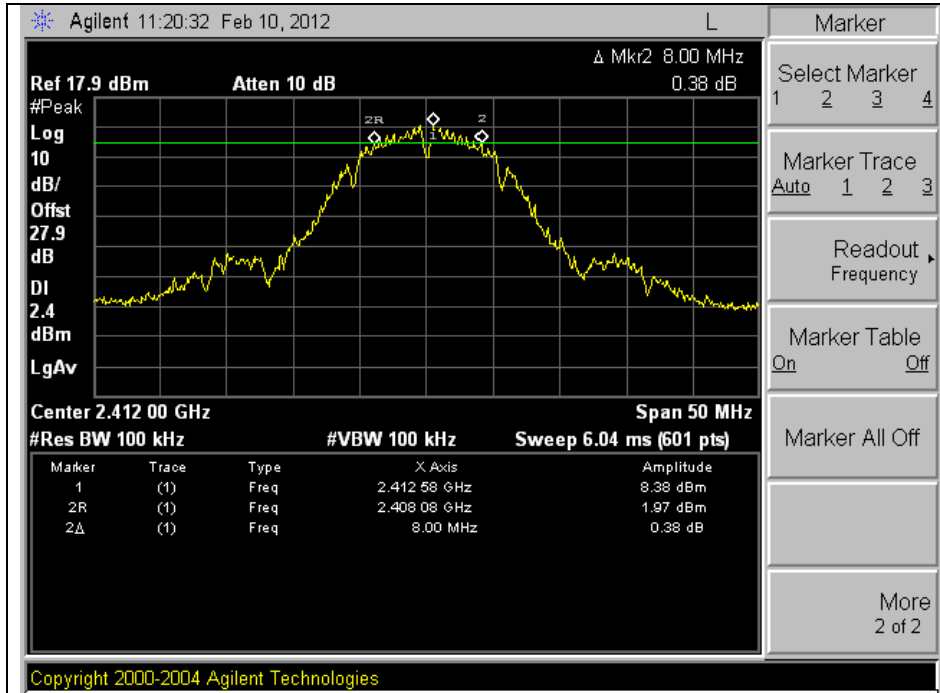

Middle Channel

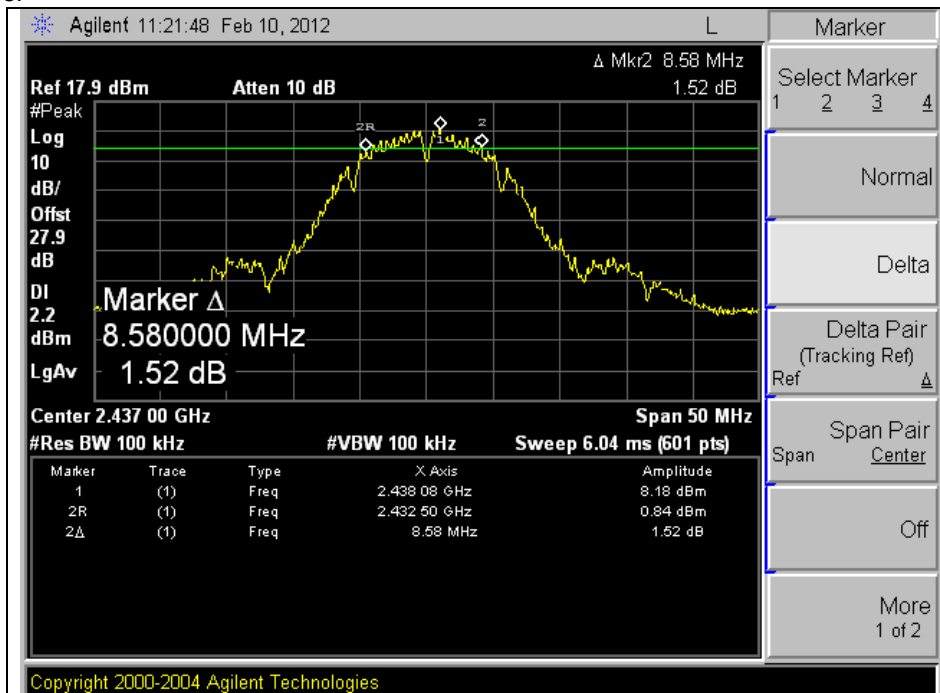

The results shown in this test report refer only to the sample(s) tested unless otherwise stated. This test report cannot be reproduced, except in full, without prior written permission of the Company.

High Channel

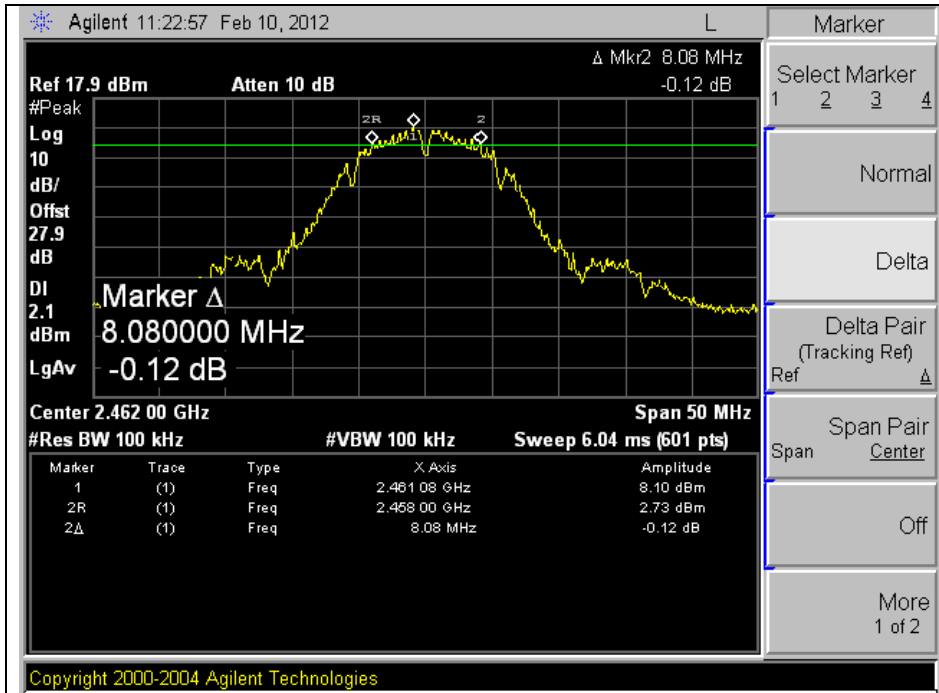

OFDM : 802.11g

Low Channel

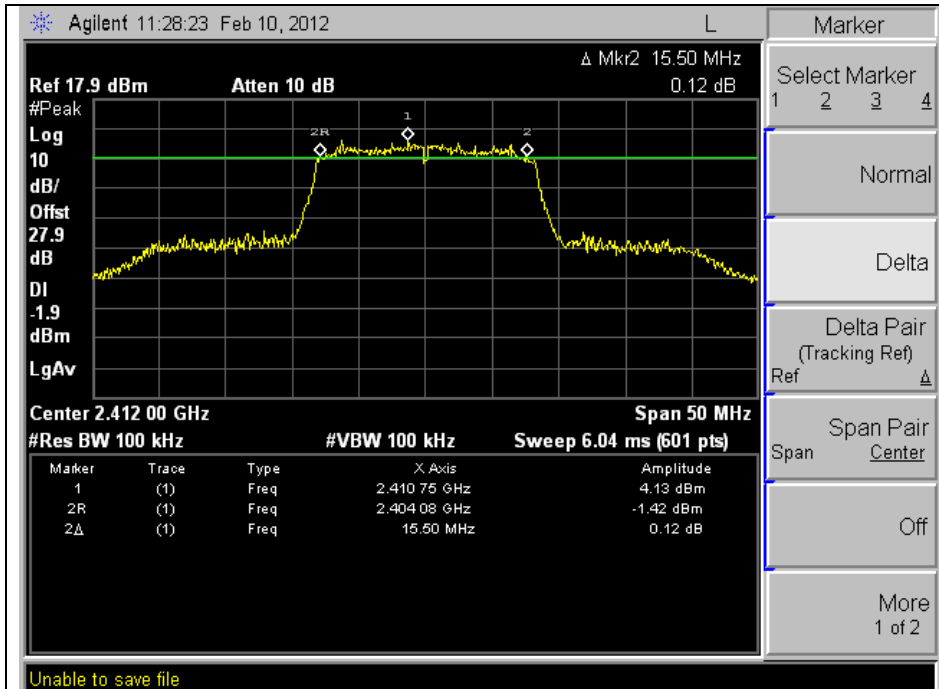

The results shown in this test report refer only to the sample(s) tested unless otherwise stated. This test report cannot be reproduced, except in full, without prior written permission of the Company.

Middle Channel

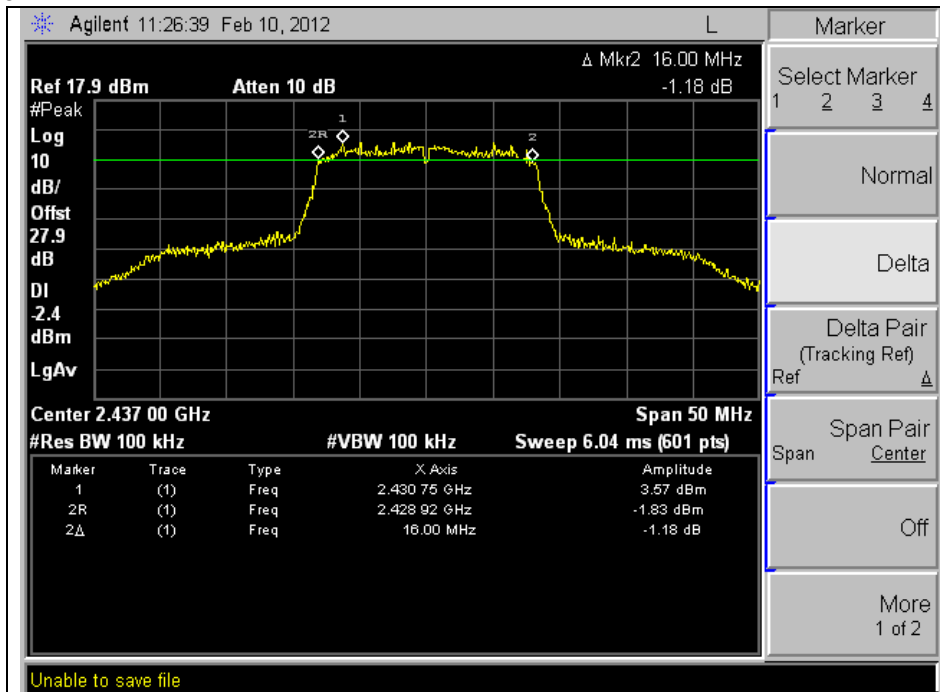

High Channel

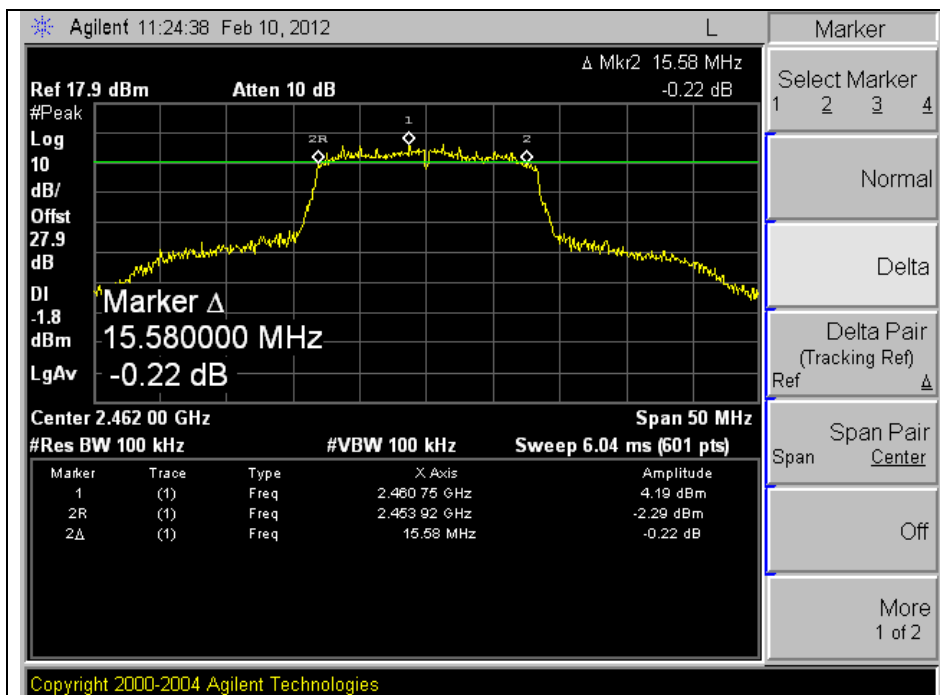

The results shown in this test report refer only to the sample(s) tested unless otherwise stated. This test report cannot be reproduced, except in full, without prior written permission of the Company.

**OFDM : 802.11n**

Low Channel

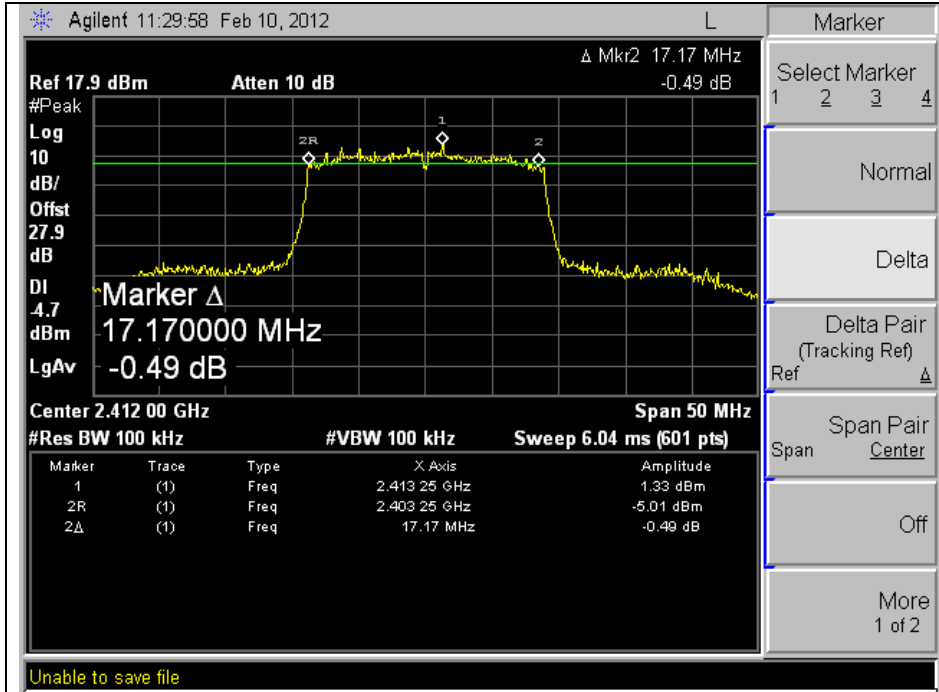

Middle Channel

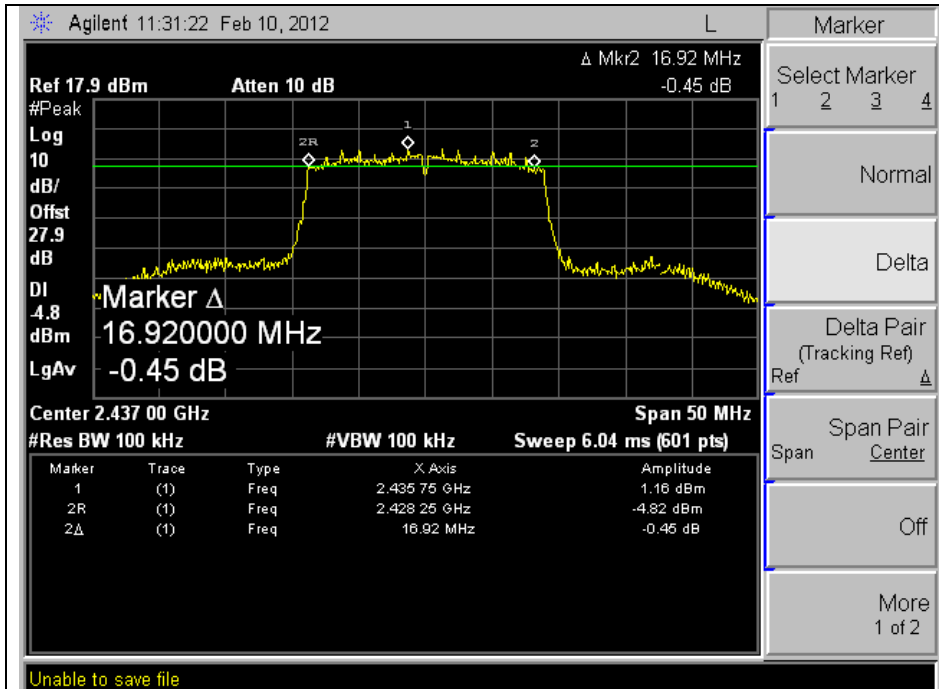

The results shown in this test report refer only to the sample(s) tested unless otherwise stated. This test report cannot be reproduced, except in full, without prior written permission of the Company.

High Channel

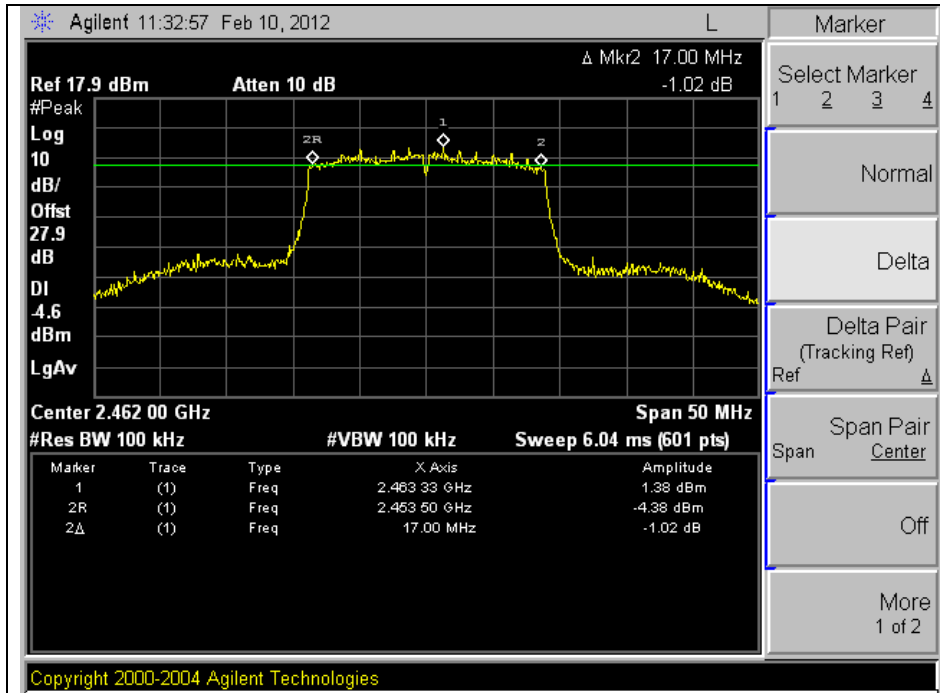

The results shown in this test report refer only to the sample(s) tested unless otherwise stated. This test report cannot be reproduced, except in full, without prior written permission of the Company.

**99% Bandwidth**

**DSSS : 802.11b**

Low Channel

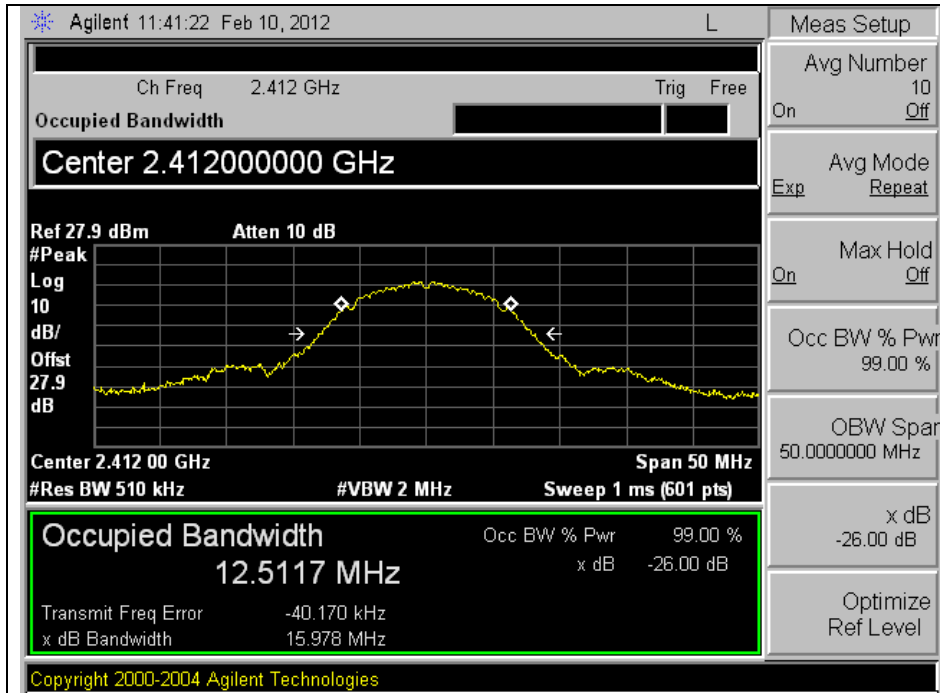

Middle Channel

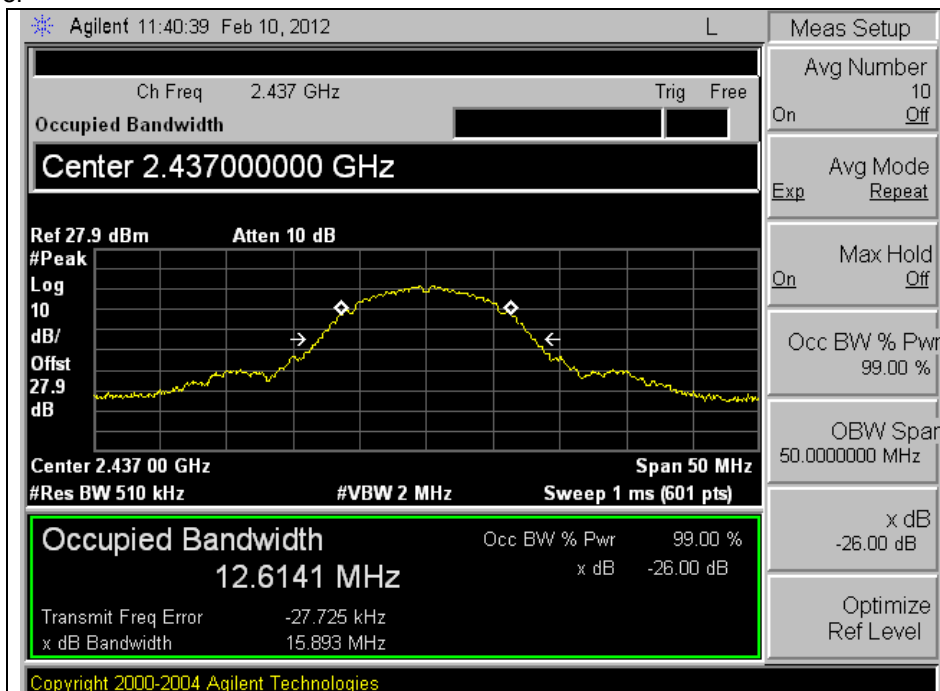

The results shown in this test report refer only to the sample(s) tested unless otherwise stated. This test report cannot be reproduced, except in full, without prior written permission of the Company.

High Channel

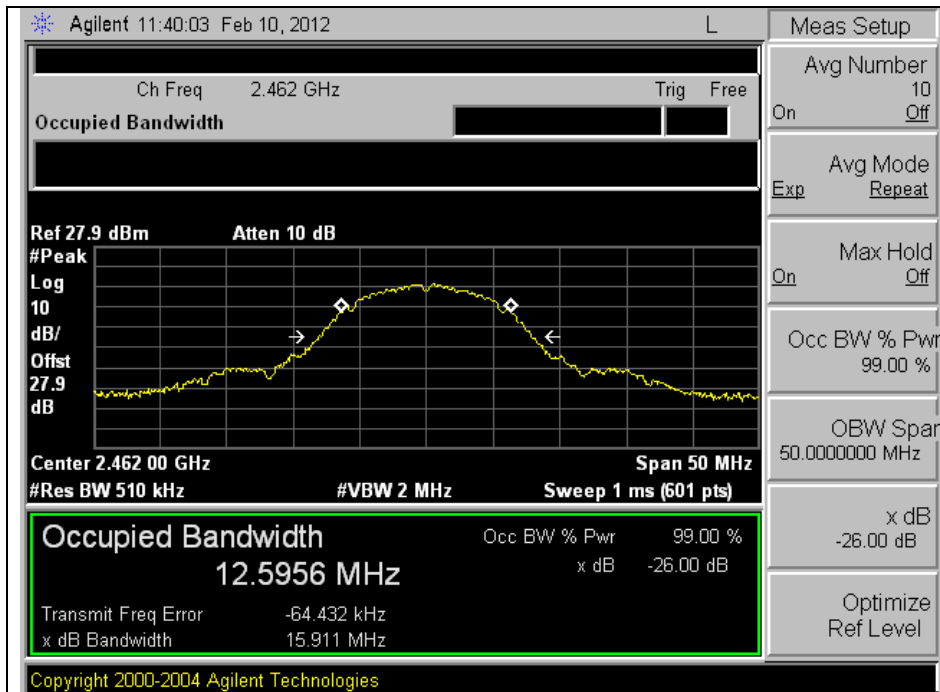

OFDM : 802.11g

Low Channel

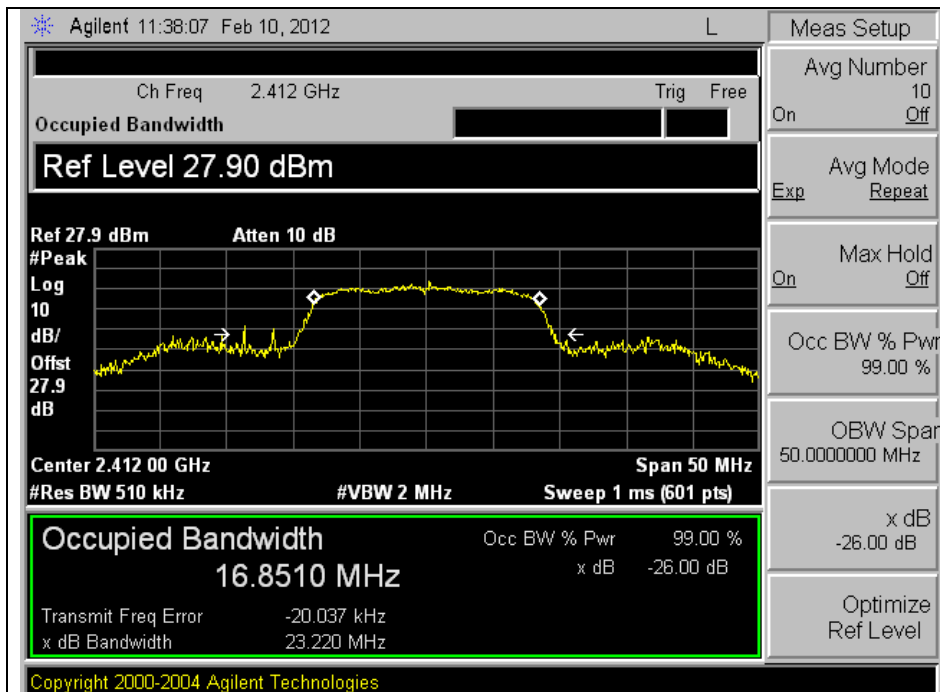

The results shown in this test report refer only to the sample(s) tested unless otherwise stated. This test report cannot be reproduced, except in full, without prior written permission of the Company.

Middle Channel

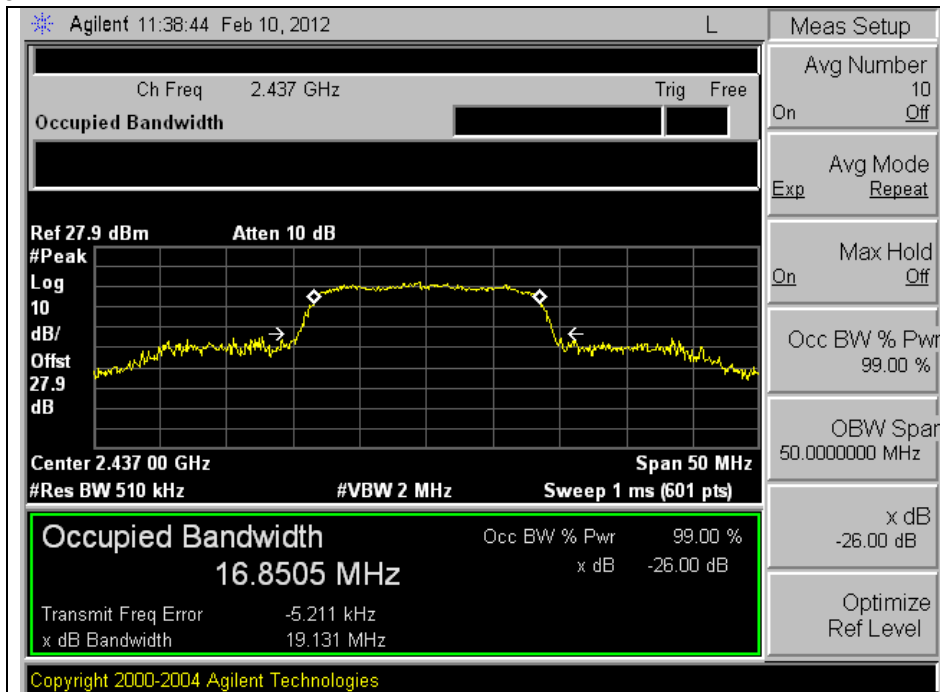

High Channel

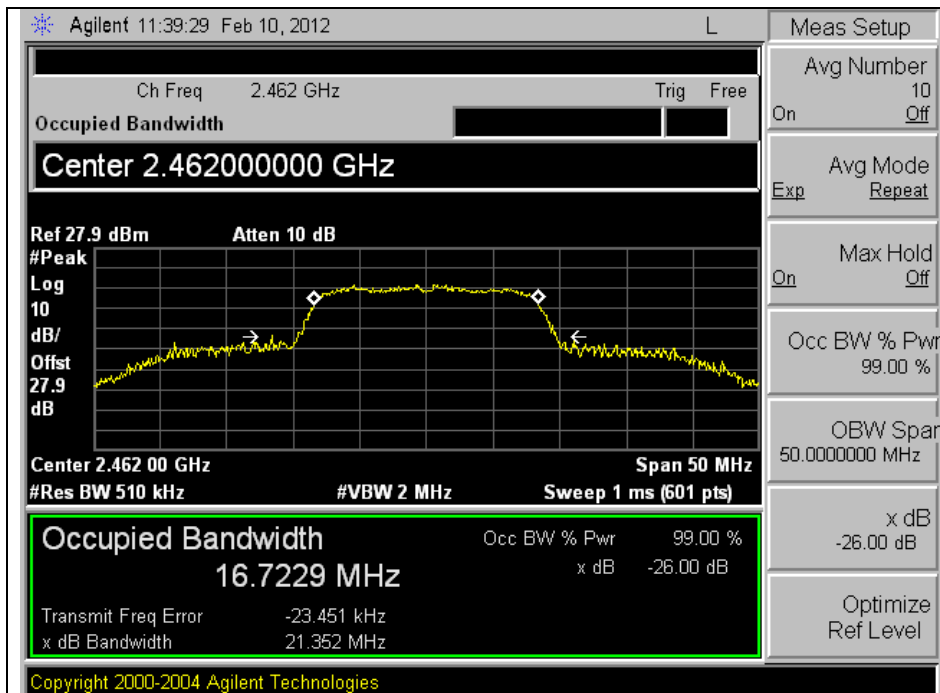

The results shown in this test report refer only to the sample(s) tested unless otherwise stated. This test report cannot be reproduced, except in full, without prior written permission of the Company.

**OFDM : 802.11n**

Low Channel

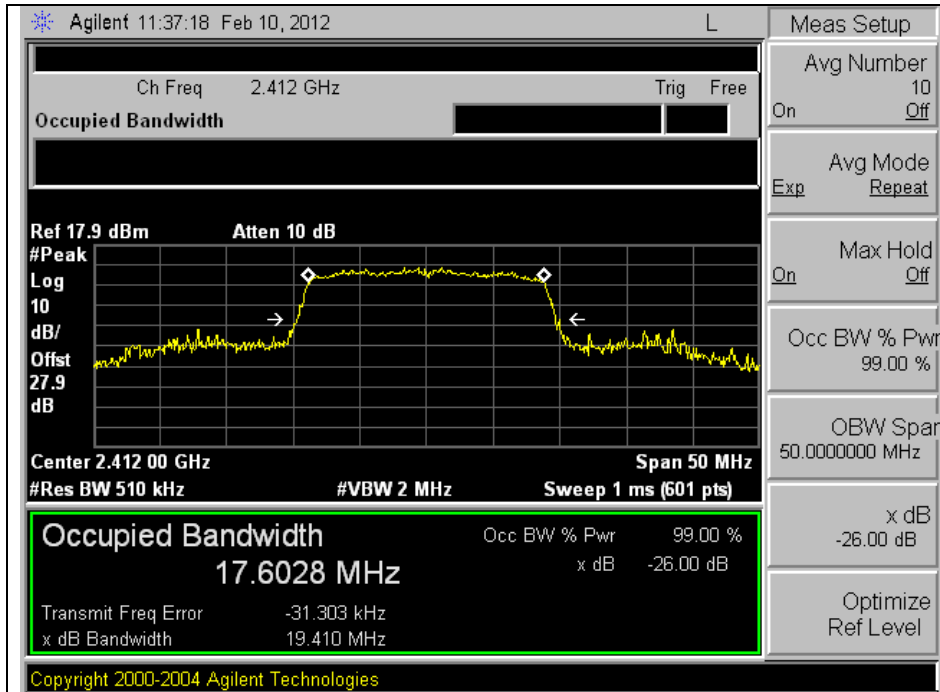

Middle Channel

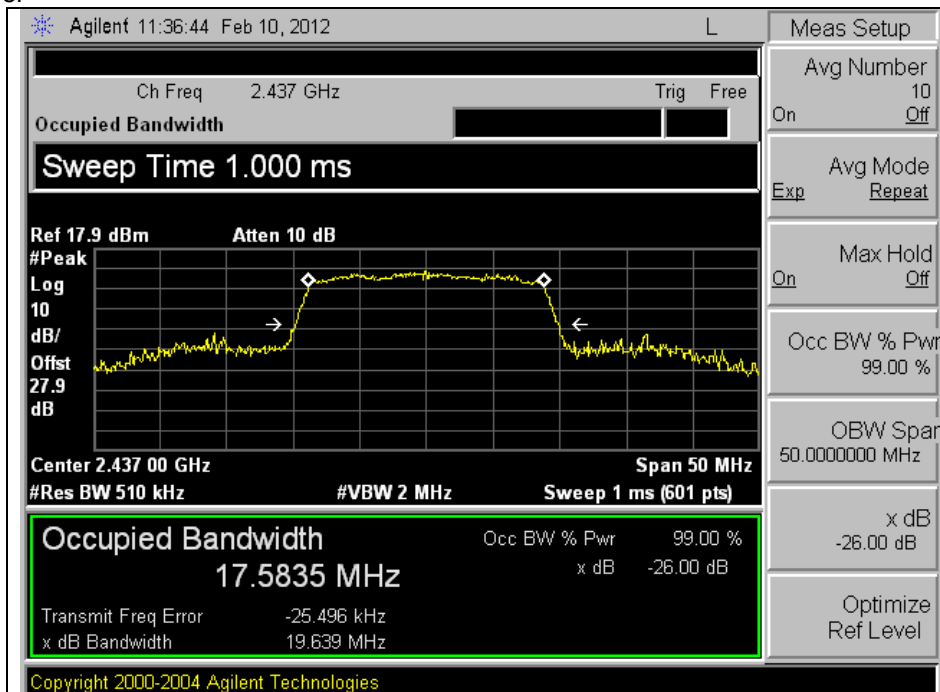

The results shown in this test report refer only to the sample(s) tested unless otherwise stated. This test report cannot be reproduced, except in full, without prior written permission of the Company.

High Channel

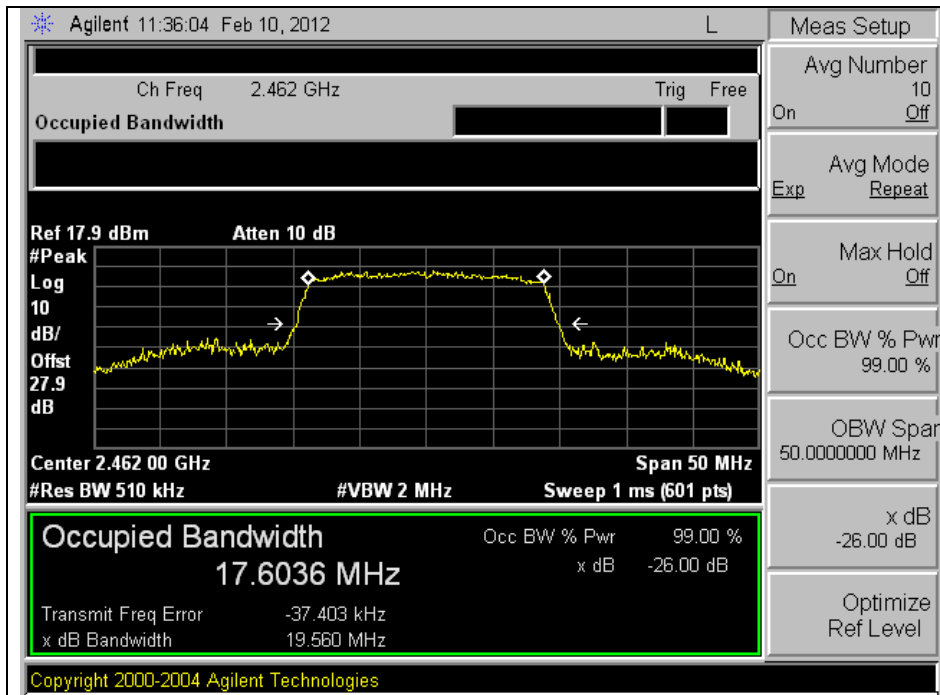

The results shown in this test report refer only to the sample(s) tested unless otherwise stated. This test report cannot be reproduced, except in full, without prior written permission of the Company.

## 5. Maximum Peak Output Power Measurement

### 5.1. Test Setup

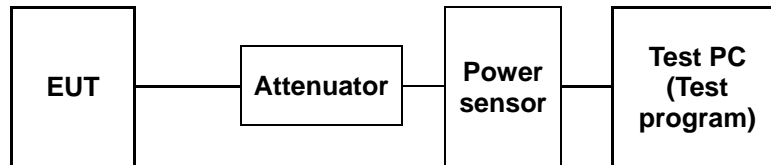

### 5.2. Limit

According to §15.247(b)(3), for systems using digital modulation in the 902 ~ 928 MHz, 2 400 ~2 483.5 MHz, and 5 725 ~ 5 850 MHz band: 1 Watt. As an alternative to a peak power measurement, compliance with the one watt limit can be based on a measurement of the maximum conducted output power. Maximum Conducted output Power is defined as the total transmit power delivered to all antennas and antenna elements averaged across all symbols in the signaling alphabet when the transmitter is operating at its maximum power control level. Power must be summed across all antenna elements. The average must not include any intervals during which the transmitter is off or is transmitting at a reduced power level. If multiple modes of operation are possible (e.g., alternative modulation methods), the maximum conducted output power is the highest total transmit power occurring in any mode.

According to §15.247(b)(4), the conducted output power limit specified in paragraph(b) of this section is based on the use of antenna with directional gains that do not exceed 6 dBi. Except as shown in paragraph(c) of this section, if transmitting antenna of directional gain greater than 6 dBi are used, the conducted output power from the intentional radiator shall be reduced below the stated values in paragraph (b)(1), (b)(2), and (b)(3) of this section , as appropriate, by the amount in dB that the directional gain of the antenna exceeds 6dBi.

### 5.3. Test Procedure

1. Place the EUT on the table and set it in the transmitting mode.
2. Remove the antenna from the EUT and then connect a low loss RF cable from the antenna port to power sensor.
3. Adjust the period of operating transmission in test program in order to use power sensor and then measure average power and peak power about each data rate of WLAN at the appropriate frequencies.
4. Record in the test report.

*The results shown in this test report refer only to the sample(s) tested unless otherwise stated. This test report cannot be reproduced, except in full, without prior written permission of the Company.*

### 5.4. Test result

Ambient temperature : (24 ± 2) °C

Relative humidity : 47 % R.H.

Mode	Channel Frequency (MHz)	Channel	Data rate (Mbps)	Attenuator + Cable offset (dB)	Average power Result (dB m)	Peak Power Result (dB m)
DSSS (802.11b)	2 412	Low	1	16.50	<b>16.20</b>	<b>19.65</b>
			2		16.17	19.51
			5.5		16.13	19.47
			11		16.03	19.60
	2 437	Middle	1	16.52	<b>16.27</b>	<b>19.70</b>
			2		16.24	19.55
			5.5		16.20	19.69
			11		16.10	19.62
	2 462	High	1	16.51	<b>16.12</b>	<b>19.42</b>
			2		16.02	19.39
			5.5		16.07	19.38
			11		15.87	19.40
OFDM (802.11g)	2 412	Low	6	16.50	<b>15.52</b>	<b>24.85</b>
			9		15.36	24.68
			12		15.25	24.43
			18		15.11	24.48
			24		14.90	24.50
			36		14.63	24.58
			48		14.31	24.75
			54		14.13	24.80
	2 437	Middle	6	16.52	<b>15.56</b>	<b>24.74</b>
			9		15.41	24.71
			12		15.38	24.51
			18		15.14	24.57
			24		14.96	24.51
			36		14.66	24.59
			48		14.35	24.60
			54		14.25	24.65
	2 462	High	6	16.51	<b>15.51</b>	<b>24.49</b>
			9		15.29	24.23
			12		15.24	23.95
			18		15.08	24.13
			24		14.92	24.22
			36		14.56	24.37
			48		14.27	24.27
			54		14.14	24.26

The results shown in this test report refer only to the sample(s) tested unless otherwise stated. This test report cannot be reproduced, except in full, without prior written permission of the Company.

Mode	Channel Frequency (MHz)	Channel	Data rate (Mbps)	Attenuator + Cable offset (dB)	Average power Result (dB m)	Peak Power Result (dB m)
OFDM (802.11n)	2 412	Low	MCS0	16.50	<b>12.28</b>	<b>24.24</b>
			MCS1		12.15	23.86
			MCS2		11.76	23.89
			MCS3		11.36	23.75
			MCS4		11.30	23.82
			MCS5		11.19	23.67
			MCS6		11.01	24.15
			MCS7		10.89	23.66
	2 437	Middle	MCS0	16.52	<b>12.24</b>	<b>24.19</b>
			MCS1		12.15	24.07
			MCS2		11.97	23.87
			MCS3		11.79	23.71
			MCS4		11.46	23.56
			MCS5		11.19	23.74
			MCS6		11.04	24.03
			MCS7		10.96	23.67
	2 462	High	MCS0	16.51	<b>12.29</b>	<b>23.40</b>
			MCS1		12.03	23.06
			MCS2		11.89	23.20
			MCS3		11.64	23.05
			MCS4		11.33	23.14
			MCS5		11.02	23.02
			MCS6		10.86	23.30
			MCS7		10.85	23.21

The results shown in this test report refer only to the sample(s) tested unless otherwise stated. This test report cannot be reproduced, except in full, without prior written permission of the Company.

---

## 6. POWER SPECTRAL DENSITY MEASUREMENT

### 6.1. Test Setup

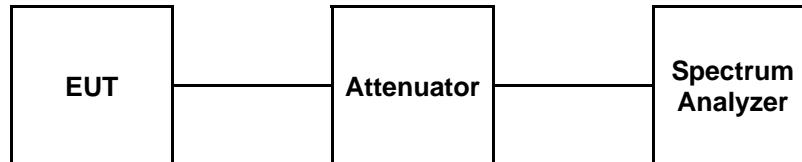

### 6.2. Limit

§15.247(e) For digitally modulated system, the power spectral density conducted from the intentional radiator to the antenna shall not be greater than 8 dB m in any 3 kHz band any time interval of continuous transmission. This power spectral density shall be determined in accordance with the provisions of paragraph (b) of this section. The same method of determining the conducted output power shall be used to determine the power spectral density.

### 6.3. Test Procedure

1. Place the EUT on the table and set it in transmitting mode.  
Remove the antenna from the EUT and then connect a low loss RF cable from the antenna port to the spectrum analyzer.
2. Set the spectrum analyzer as RBW = 3 kHz, VBW = 10 kHz, Span = 300 kHz and Sweep = 100 s.
3. Record the max. reading.
4. Repeat the above procedure until the measurements for all frequencies are completed.

---

*The results shown in this test report refer only to the sample(s) tested unless otherwise stated. This test report cannot be reproduced, except in full, without prior written permission of the Company.*

## 6.4. Test Results

Ambient temperature : (24 ± 2) °C  
 Relative humidity : 47 % R.H.

Operation Mode	Frequency	Final RF Power Level in 3 kHz BW (dB m)	Maximum Limit (dB m)
DSSS (802.11b)	2 412 MHz	-3.93	8
	2 437 MHz	-3.67	8
	2 462 MHz	-4.24	8
OFDM (802.11g)	2 412 MHz	-9.11	8
	2 437 MHz	-9.19	8
	2 462 MHz	-8.92	8
OFDM (802.11n)	2 412 MHz	-11.69	8
	2 437 MHz	-11.45	8
	2 462 MHz	-11.52	8

*The results shown in this test report refer only to the sample(s) tested unless otherwise stated. This test report cannot be reproduced, except in full, without prior written permission of the Company.*

**DSSS : 802.11b**

Low Channel

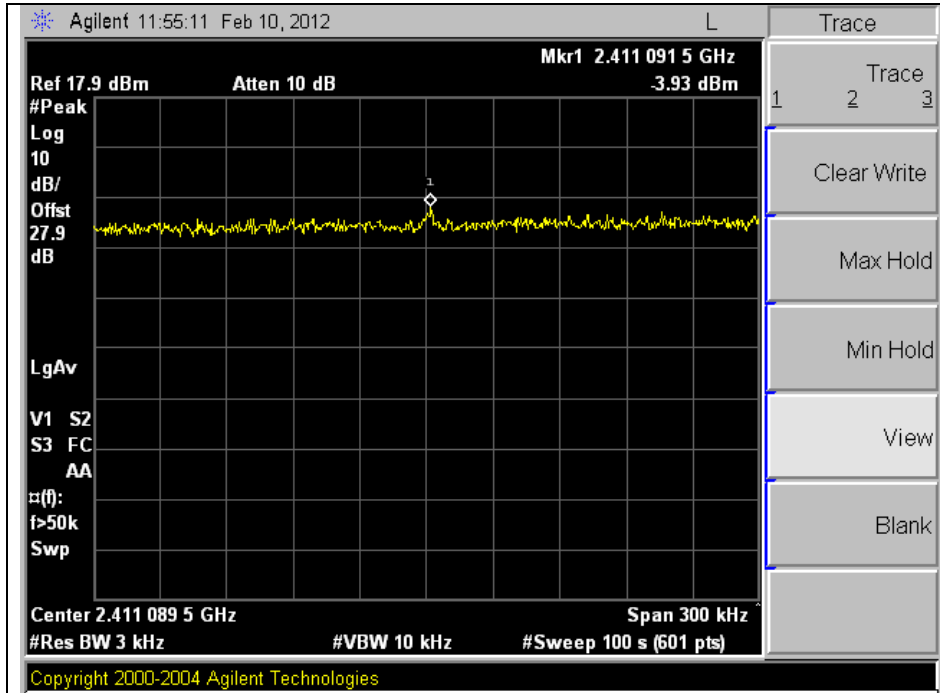

Middle Channel

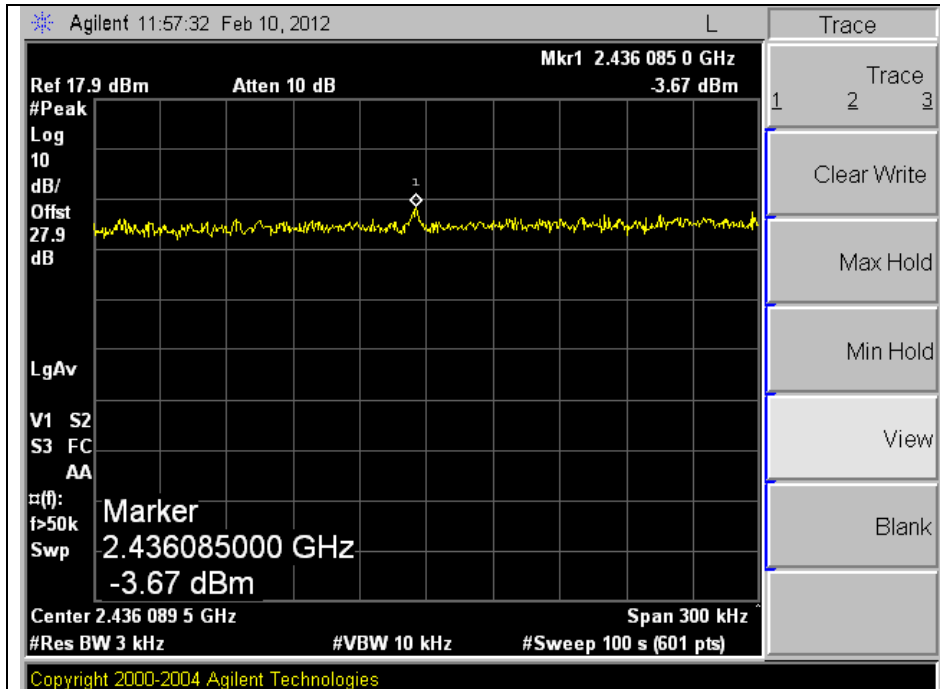

The results shown in this test report refer only to the sample(s) tested unless otherwise stated. This test report cannot be reproduced, except in full, without prior written permission of the Company.

High Channel

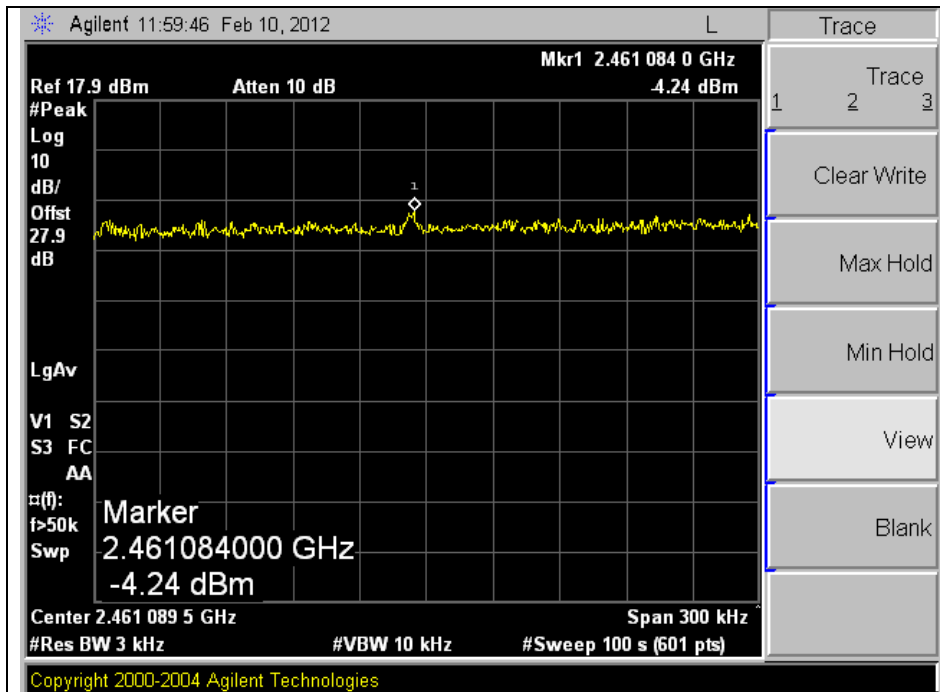

OFDM : 802.11g

Low Channel

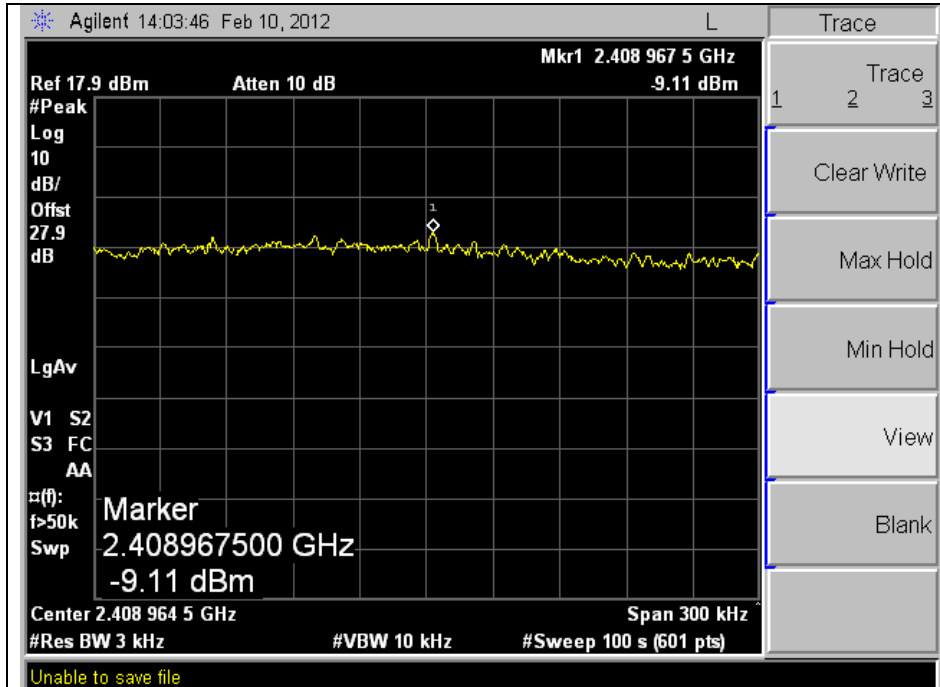

The results shown in this test report refer only to the sample(s) tested unless otherwise stated. This test report cannot be reproduced, except in full, without prior written permission of the Company.

Middle Channel

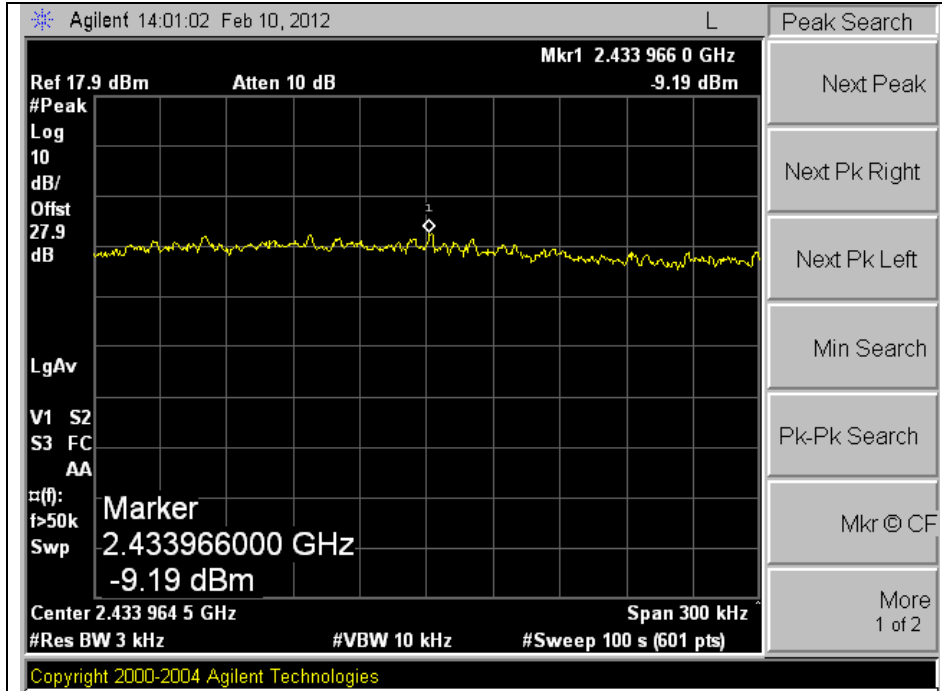

High Channel

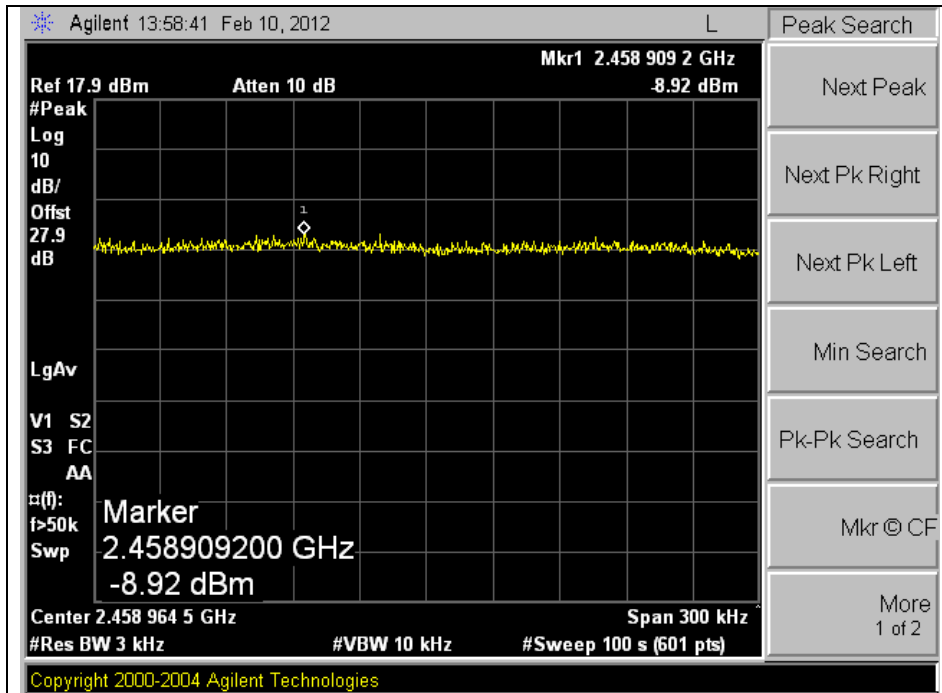

The results shown in this test report refer only to the sample(s) tested unless otherwise stated. This test report cannot be reproduced, except in full, without prior written permission of the Company.

**DSSS : 802.11n**  
Low Channel

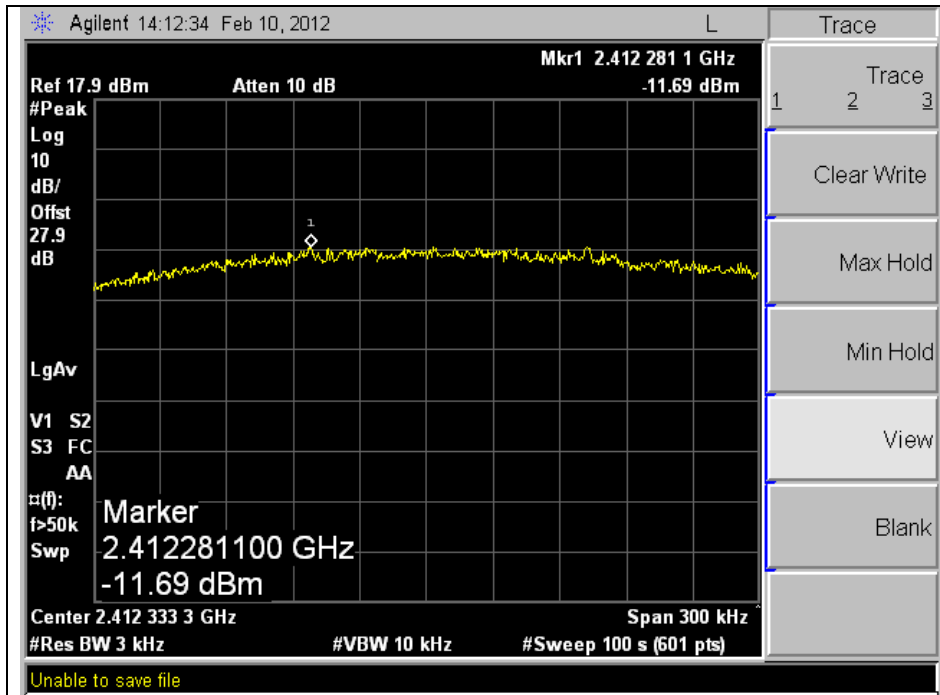

Middle Channel

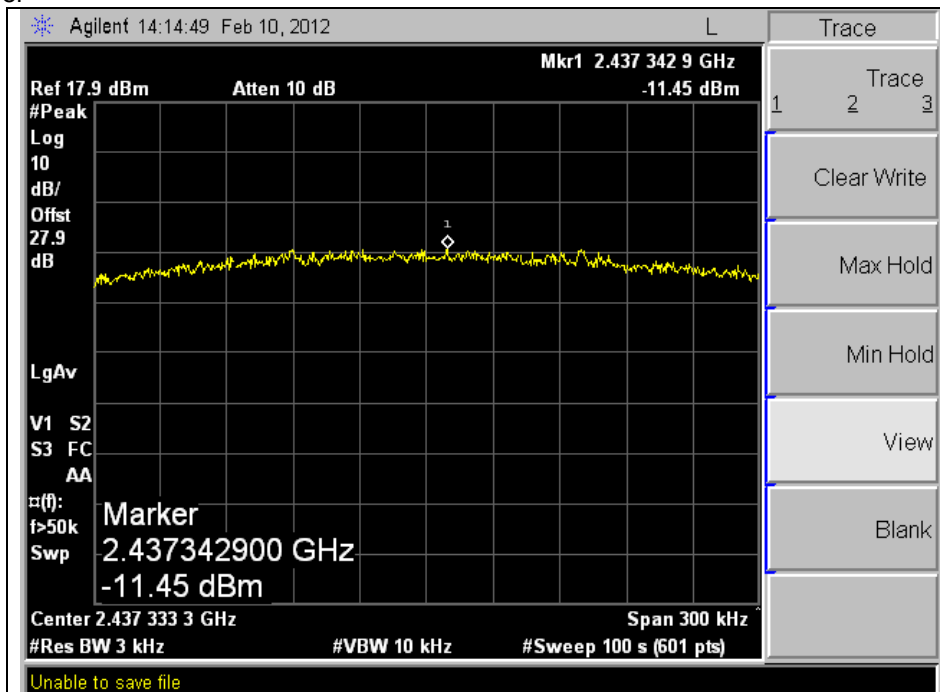

The results shown in this test report refer only to the sample(s) tested unless otherwise stated. This test report cannot be reproduced, except in full, without prior written permission of the Company.

High Channel

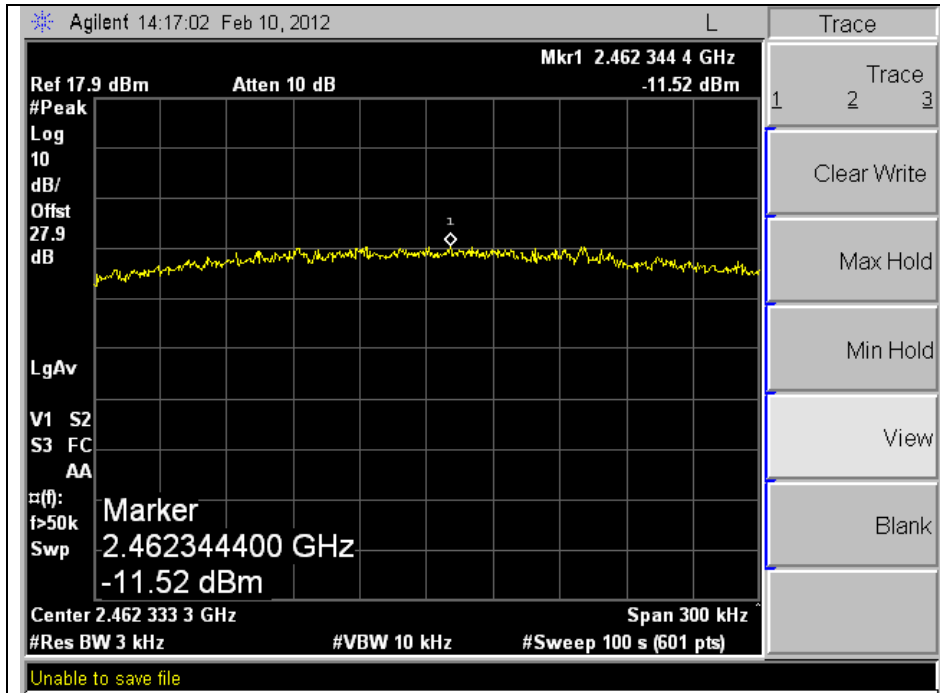

The results shown in this test report refer only to the sample(s) tested unless otherwise stated. This test report cannot be reproduced, except in full, without prior written permission of the Company.

## 7. Transmitter AC Power Line Conducted Emission

### 7.1. Test Setup

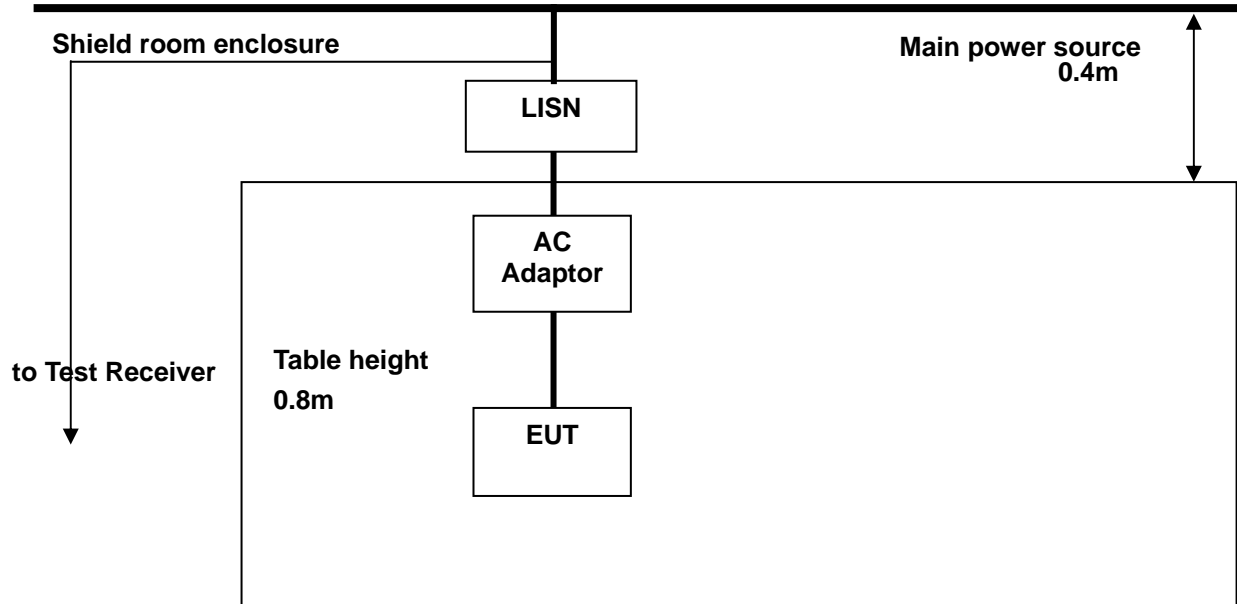

### 7.2. Limit

According to §15.207(a) for an intentional radiator that is designed to be connected to the public utility (AC) power line, the radio frequency voltage that is conducted back onto the AC power line on any frequency or frequencies, within the band 150 kHz to 30 MHz, shall not exceed the limits in the following table, as measured using a 50 uH/50 ohm line impedance stabilization network(LISN).

Compliance with the provision of this paragraph shall on the measurement of the radio frequency voltage between each power line and ground at the power terminal. The lower applies at the boundary between the frequency ranges.

Frequency of Emission (MHz)	Conducted limit (dB $\mu$ V)	
	Quasi-peak	Average
0.15 – 0.50	66 - 56*	56 - 46*
0.50 – 5.00	56	46
5.00 – 30.0	60	50

\* Decreases with the logarithm of the frequency.

The results shown in this test report refer only to the sample(s) tested unless otherwise stated. This test report cannot be reproduced, except in full, without prior written permission of the Company.

### 7.3. Test Procedures

Radiated emissions from the EUT were measured according to the dictates of ANSI C63.4:2003

1. The test procedure is performed in a 6.5m × 3.6m × 3.6m (L × W × H) shielded room. The EUT along with its peripherals were placed on a 1.0 m(W) × 1.5 m(L) and 0.8 m in height wooden table and the EUT was adjusted to maintain a 0.4 meter space from a vertical reference plane.
2. The EUT was connected to power mains through a line impedance stabilization network (LISN) which provides 50 ohm coupling impedance for measuring instrument and the chassis ground was bounded to the horizontal ground plane of shielded room.
3. The excess power cable between the EUT and the LISN was bundled. All connecting cables of EUT were moved to find the maximum emission.

---

*The results shown in this test report refer only to the sample(s) tested unless otherwise stated. This test report cannot be reproduced, except in full, without prior written permission of the Company.*

SGS Korea Co., Ltd. (Gunpo Laboratory) 18-34, Sanbon-dong, Gunpo-si, Gyeonggi-do, Korea, 435-040

Tel. +82 31 428 5700 / Fax. +82 31 427 2371

[www.ee.sgs.com/korea](http://www.ee.sgs.com/korea)

#### 7.4. Test Results (Worst case configuration\_11b mode)

The following table shows the highest levels of conducted emissions on both phase of Hot and Neutral line.

Ambient temperature : (24 ± 2) °C  
 Relative humidity : 47 % R.H.

Frequency range : 0.15 MHz – 30 MHz

Measured Bandwidth : 9 kHz

FREQ. (MHz)	LEVEL(dB $\mu$ V)		LINE	LIMIT(dB $\mu$ V)		MARGIN(dB)	
	Q-Peak	Average		Q-Peak	Average	Q-Peak	Average
0.15	45.1	31.7	H	66.0	56.0	20.9	24.3
0.20	45.6	33.6	H	63.8	53.8	18.2	20.2
0.29	38.6	26.4	H	60.7	50.7	22.1	24.3
2.80	33.3	26.3	H	56.0	46.0	22.7	19.7
4.59	34.7	28.2	H	56.0	46.0	21.3	17.8
28.32	22.2	14.4	H	60.0	50.0	37.8	35.6
0.17	41.9	28.6	N	65.2	55.2	23.3	26.6
0.19	41.3	27.1	N	64.0	54.0	22.8	27.0
0.27	38.7	23.0	N	61.1	51.1	22.5	28.2
3.17	30.5	22.7	N	56.0	46.0	25.5	23.3
4.54	31.6	25.1	N	56.0	46.0	24.4	20.9
26.79	25.7	17.6	N	60.0	50.0	34.3	32.4

Note ;

Line ( H ) : Hot

Line ( N ) : Neutral

*The results shown in this test report refer only to the sample(s) tested unless otherwise stated. This test report cannot be reproduced, except in full, without prior written permission of the Company.*

**Plot of Conducted Power line**

Test mode : (Hot)

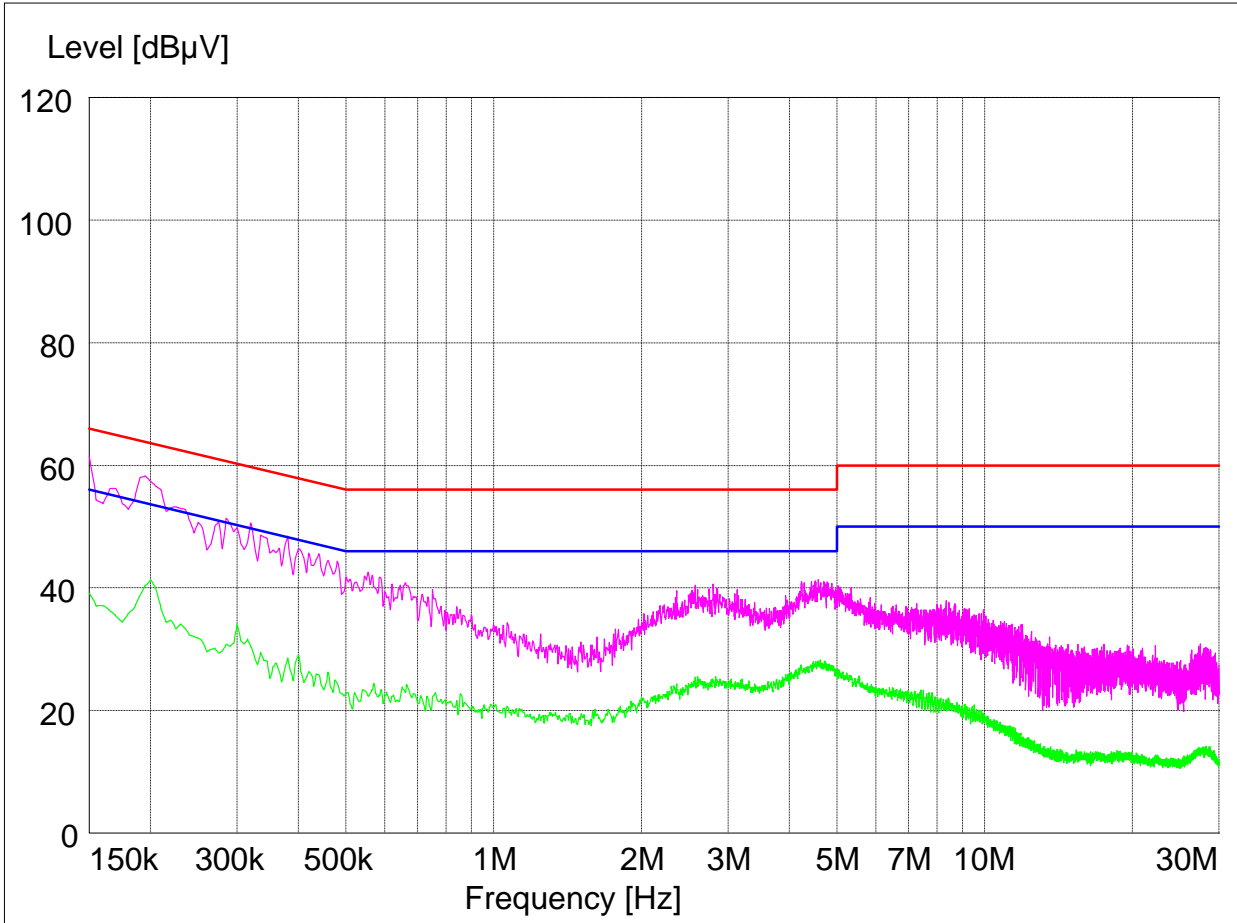

*The results shown in this test report refer only to the sample(s) tested unless otherwise stated. This test report cannot be reproduced, except in full, without prior written permission of the Company.*

Test mode : (Neutral)

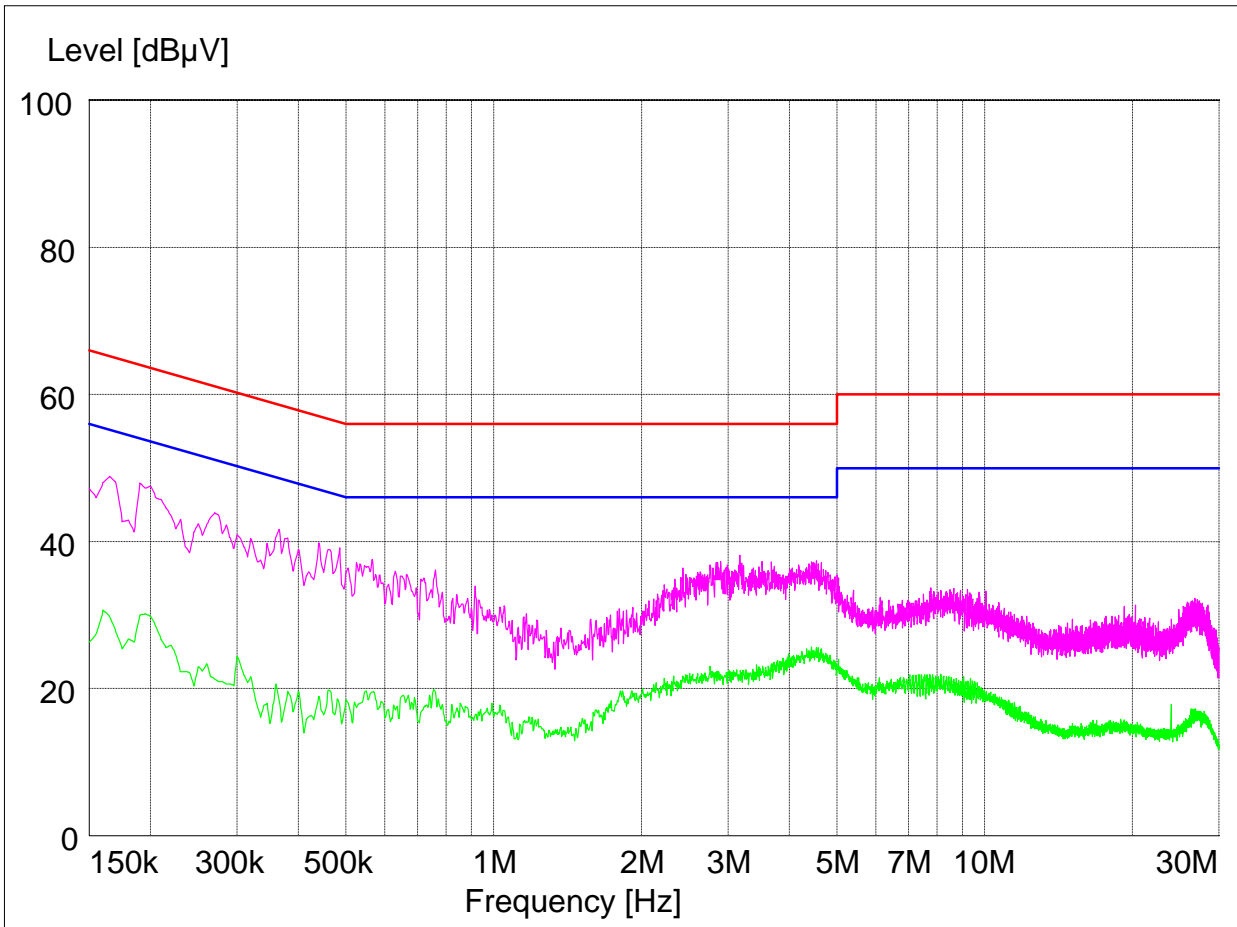

The results shown in this test report refer only to the sample(s) tested unless otherwise stated. This test report cannot be reproduced, except in full, without prior written permission of the Company.

## 8. Receiver AC Power Line Conducted Emission

### 8.1. Test Setup- Same as clause 7.1.

### 8.2. Limit

According to §15.107(a) Except for Class A digital devices, for equipment that is designed to be connected to the public utility (AC) power line, the radio frequency voltage that is conducted back onto the AC power line on any frequency or frequencies within the band 150 kHz to 30 MHz shall not exceed the limits in the following table, as measured using a 50  $\mu$ H/50 oh<sub>ms</sub> line impedance stabilization network (LISN). Compliance with the provisions of this paragraph shall be based on the measurement of the radio frequency voltage between each power line and ground at the power terminal. The lower limit applies at the band edges.

Frequency of Emission (MHz)	Conducted limit (dB $\mu$ V)	
	Quasi-peak	Average
0.15 – 0.50	66-56*	56-46*
0.50 – 5.00	56	46
5.00 – 30.0	60	50

\* Decreases with the logarithm of the frequency.

*The results shown in this test report refer only to the sample(s) tested unless otherwise stated. This test report cannot be reproduced, except in full, without prior written permission of the Company.*

### 8.3. Test Procedures- Same as clause 7.3.

### 8.4. Test Results

The following table shows the highest levels of conducted emissions on both phase of Hot and Neutral line; Addition,

Ambient temperature : (24 ± 2) °C  
 Relative humidity : 47 % R.H.

Frequency range : 0.15 MHz – 30 MHz  
 Measured Bandwidth : 9 kHz

FREQ. (MHz)	LEVEL(dB $\mu$ V)		LINE	LIMIT(dB $\mu$ V)		MARGIN(dB)	
	Q-Peak	Average		Q-Peak	Average	Q-Peak	Average
0.17	42.1	28.7	H	65.2	55.2	23.1	26.5
0.19	42.1	29.3	H	64.0	54.0	22.0	24.8
0.27	38.6	24.2	H	61.1	51.1	22.6	27.0
0.55	34.2	24.4	H	56.0	46.0	21.8	21.6
2.60	32.9	25.4	H	56.0	46.0	23.1	20.6
4.79	35.2	27.4	H	56.0	46.0	20.8	18.6
0.17	40.7	25.4	N	65.0	55.0	24.2	29.5
0.20	42.5	29.1	N	63.6	53.6	21.1	24.5
0.28	38.0	21.6	N	61.0	51.0	23.0	29.4
2.87	30.8	22.5	N	56.0	46.0	25.2	23.5
4.19	32.0	25.9	N	56.0	46.0	24.0	20.1
26.21	25.8	16.7	N	60.0	50.0	34.2	33.3

Note ;

Line ( H ) : Hot

Line ( N ) : Neutral

*The results shown in this test report refer only to the sample(s) tested unless otherwise stated. This test report cannot be reproduced, except in full, without prior written permission of the Company.*

**Plot of Conducted Power line**

Test mode : (Hot)

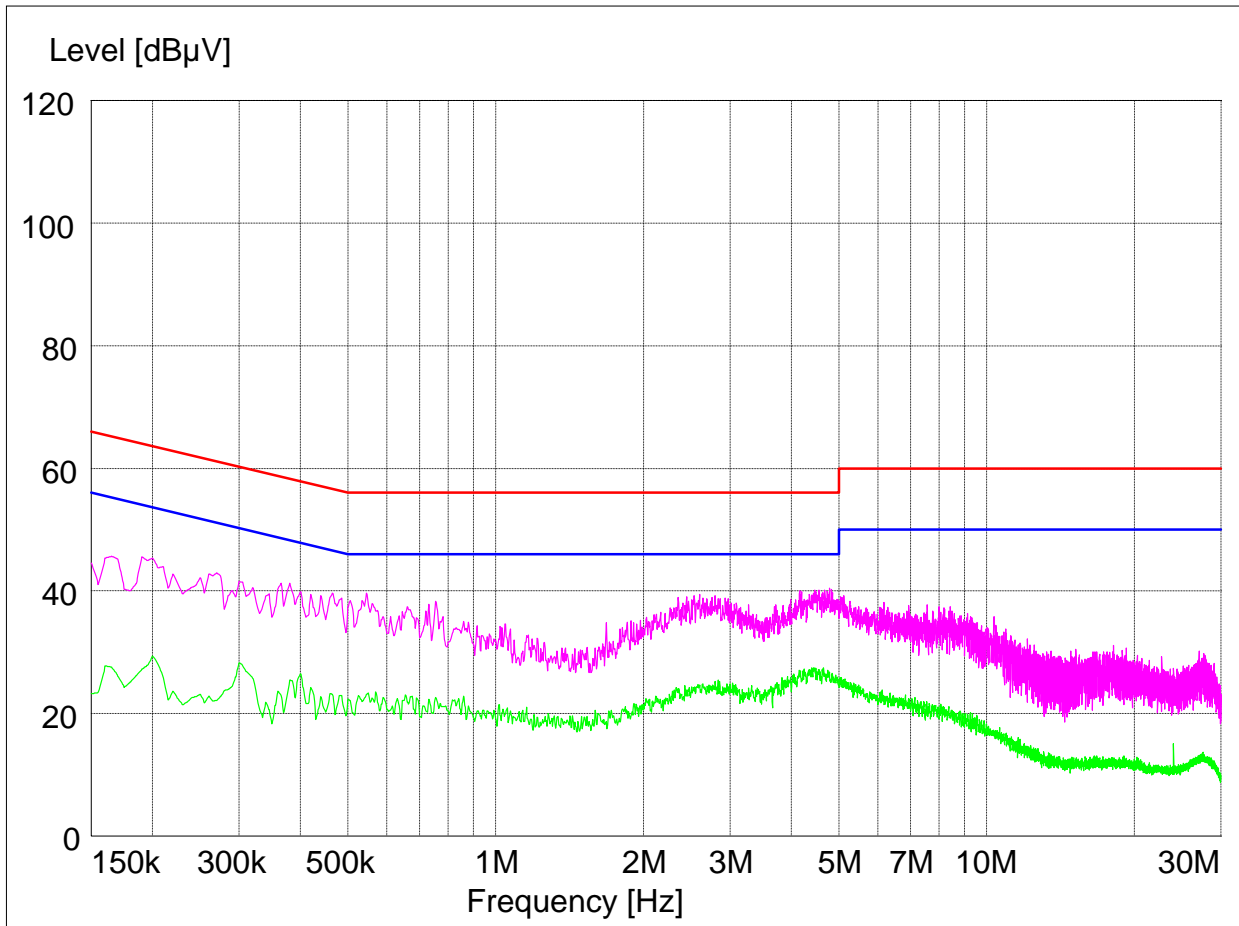

*The results shown in this test report refer only to the sample(s) tested unless otherwise stated. This test report cannot be reproduced, except in full, without prior written permission of the Company.*

Test mode : (Neutral)

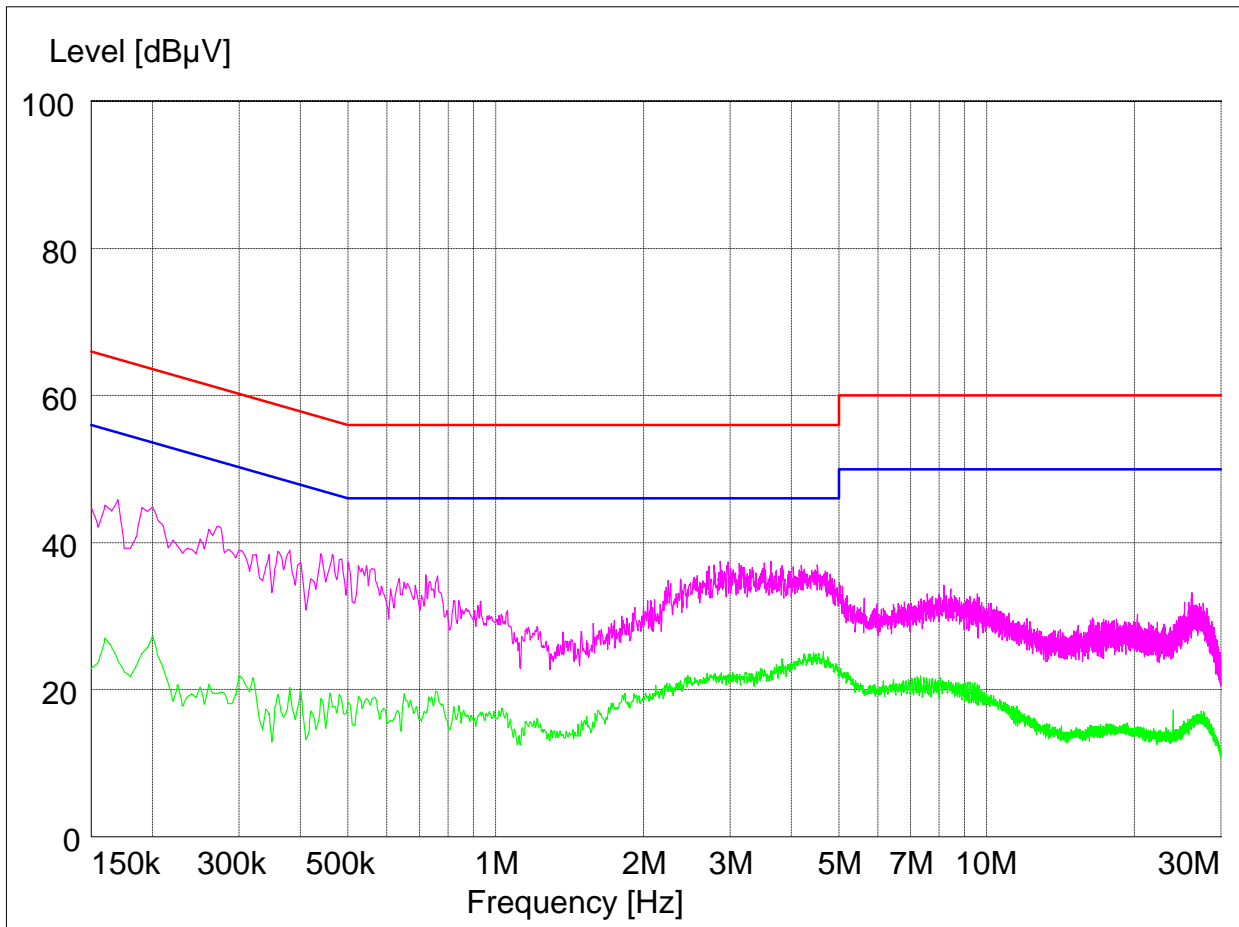

The results shown in this test report refer only to the sample(s) tested unless otherwise stated. This test report cannot be reproduced, except in full, without prior written permission of the Company.

## 9. Antenna Requirement

### 9.1. Standard Applicable

For intentional device, according to FCC 47 CFR Section §15.203, an intentional radiator shall be designed to ensure that no antenna other than that furnished by the responsible party shall be used with the device. And according to FCC 47 CFR Section §15.247 (b) if transmitting antennas of directional gain greater than 6 dB i are used, the power shall be reduced by the amount in dB that the gain of the antenna exceeds 6 dB i.

### 9.2. Antenna Connected Construction

Antenna used in this product is Integral type (FPCB Antenna ) gain of 1.5 dB i.

---

*The results shown in this test report refer only to the sample(s) tested unless otherwise stated. This test report cannot be reproduced, except in full, without prior written permission of the Company.*

SGS Korea Co., Ltd. (Gunpo Laboratory) 18-34, Sanbon-dong, Gunpo-si, Gyeonggi-do, Korea, 435-040

Tel. +82 31 428 5700 / Fax. +82 31 427 2371

[www.ee.sgs.com/korea](http://www.ee.sgs.com/korea)

## 10. RF Exposure Evaluation

### 10.1 Environmental evaluation and exposure limit according to FCC CFR 47 part 1, 1.1307(b), 1.1310

According to FCC 1.1310 : The criteria listed in the following table shall be used to evaluate the environment impact of human exposure to radio frequency (RF) radiation as specified in §1.1307(b)

#### LIMITS FOR MAXIMUM PERMISSIBLE EXPOSURE (MPE)

Frequency Range (MHz)	Electric Field Strength(V/m)	Magnetic Field Strength (A/m)	Power Density (mW/cm <sup>2</sup> )	Average Time
(A) Limits for Occupational /Control Exposures				
300 – 1 500	--	--	F/300	6
1 500 – 100 000	--	--	5	6
(B) Limits for General Population/Uncontrol Exposures				
300 – 1 500	--	--	F/1500	6
<b><u>1 500 – 100 000</u></b>	--	--	<b><u>1</u></b>	<b><u>30</u></b>

#### 10.1.1. Friis transmission formula: $Pd = (Pout \cdot G) / (4 \cdot \pi \cdot R^2)$

Where Pd = power density in mW/cm<sup>2</sup>

Pout = output power to antenna in mW

G = gain of antenna in linear scale

Pi = 3.1416

R = distance between observation point and center of the radiator in cm

Pd the limit of MPE, 1 mW/cm<sup>2</sup>. If we know the maximum gain of the antenna and the total power input to the antenna, through the calculation, we will know the distance where the MPE limit is reached.

*The results shown in this test report refer only to the sample(s) tested unless otherwise stated. This test report cannot be reproduced, except in full, without prior written permission of the Company.*

### 10.1.2. Test Result of RF Exposure Evaluation

Test Item : RF Exposure Evaluation Data

Test Mode : Normal Operation

### 10.1.3. Output Power into Antenna & RF Exposure Evaluation Distance

#### DSSS : 802.11b

Channel	Channel Frequency (MHz)	Output Average Power to Antenna (dB m)	Antenna Gain (dB i)	Power Density at 20 cm (mW/cm <sup>2</sup> )	LIMITS (mW/cm <sup>2</sup> )
Low	2 412	16.20	1.5	0.011 598	1
Middle	2 437	16.27	1.5	0.011 786	1
High	2 462	16.12	1.5	0.011 386	1

#### OFDM : 802.11g

Channel	Channel Frequency (MHz)	Output Average Power to Antenna (dB m)	Antenna Gain (dB i)	Power Density at 20 cm (mW/cm <sup>2</sup> )	LIMITS (mW/cm <sup>2</sup> )
Low	2 412	15.52	1.5	0.009 516	1
Middle	2 437	15.56	1.5	0.009 604	1
High	2 462	15.51	1.5	0.009 494	1

#### OFDM : 802.11n

Channel	Channel Frequency (MHz)	Output Average Power to Antenna (dB m)	Antenna Gain (dB i)	Power Density at 20 cm (mW/cm <sup>2</sup> )	LIMITS (mW/cm <sup>2</sup> )
Low	2 412	12.28	1.5	0.004 513	1
Middle	2 437	12.24	1.5	0.004 472	1
High	2 462	12.29	1.5	0.004 523	1

Note :

1. The power density Pd (5th column) at a distance of 20 cm calculated from the friis transmission formula is far below the limit of 1 mW/cm<sup>2</sup> .

Because the average output power is lower than 60/f(GHz), SAR evaluation is not required per KDB 447498

*The results shown in this test report refer only to the sample(s) tested unless otherwise stated. This test report cannot be reproduced, except in full, without prior written permission of the Company.*