

PCTEST ENGINEERING LABORATORY, INC.

DUT: Dipole 835 MHz; Type: D835V2; Serial: 406

Communication System: CW; Frequency: 835 MHz; Duty Cycle: 1:1

Medium: 835 Brain ($\sigma = 0.91$ mho/m, $\epsilon_r = 40.13$, $\rho = 1000$ kg/m³)

Phantom section: Flat Section; Space: 1.5 cm

Test Date: 02-24-2004; Ambient Temp: 23.8°C; Tissue Temp: 20.5°C

Probe: ES3DV2 - SN3022; ConvF(6.1, 6.1, 6.1); Calibrated: 9/23/2003

Sensor-Surface: 4mm (Mechanical Surface Detection)

Electronics: DAE3 Sn445; Phantom: SAM 12b; Type: SAM 4.0; Serial: TP:1197

Measurement SW: DASY4, V4.1 Build 47; Postprocessing SW: SEMCAD, V1.8 Build 93

835 MHz Dipole Validation

Area Scan (61x121x1): Measurement grid: dx=15mm, dy=15mm

Zoom Scan (7x7x7)/Cube 0: Measurement grid: dx=5mm, dy=5mm, dz=5mm

Input Power = 24.0 dBm (250 mW)

SAR(1 g) = 2.44 mW/g; SAR(10 g) = 1.59 mW/g

Target SAR(1g) = 2.375 mW/g; Deviation = +2.74 %

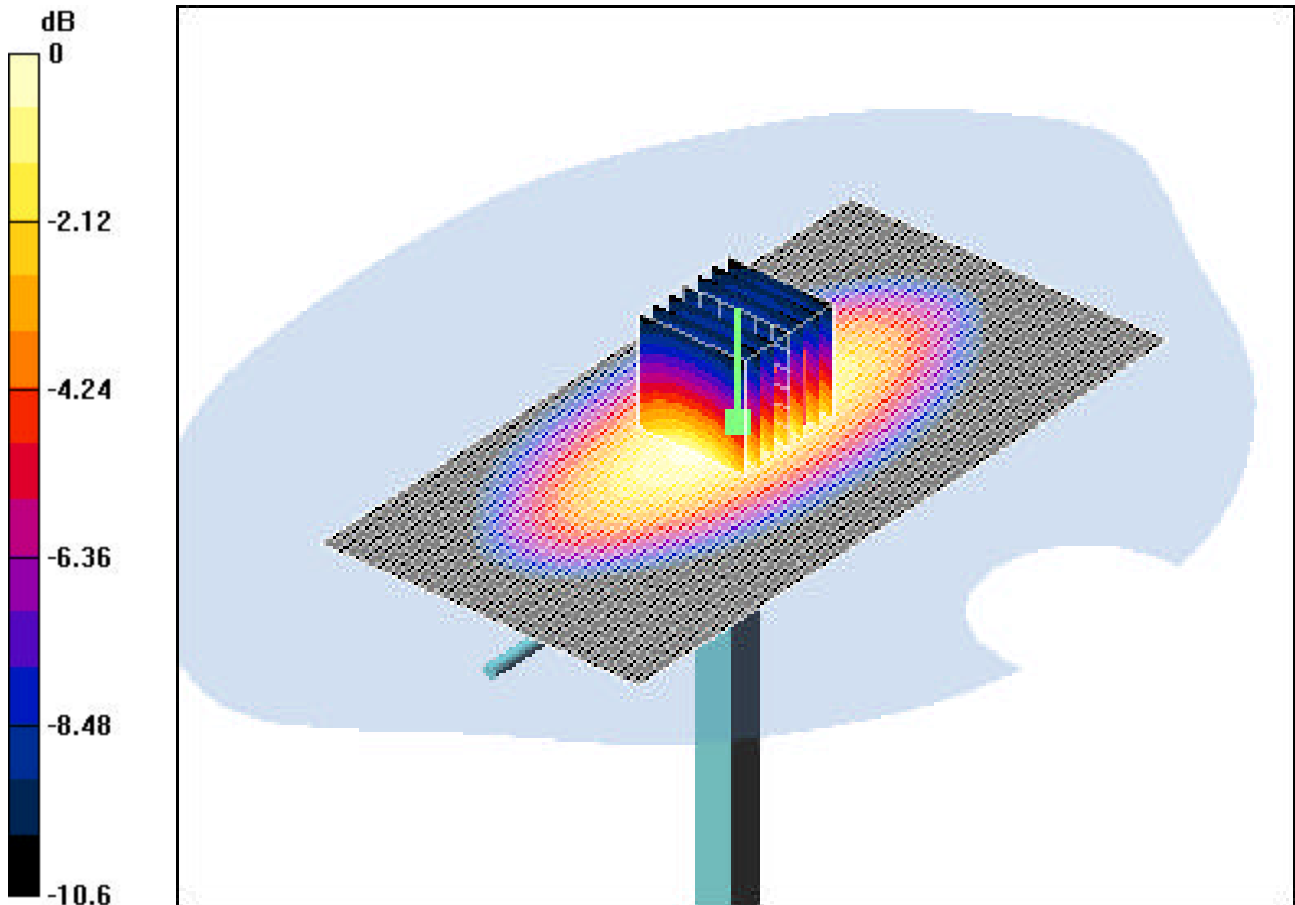

PCTEST ENGINEERING LABORATORY, INC.

DUT: Dipole 1900 MHz; Type: D1900V2; Serial: 502

Communication System: CW; Frequency: 1900 MHz; Duty Cycle: 1:1

Medium: 1900 Brain ($\sigma = 1.45$ mho/m, $\epsilon_r = 39.51$, $\rho = 1000$ kg/m³)

Phantom section: Flat Section; Space: 1.0 cm

Test Date: 02-23-2004; Ambient Temp: 23.6°C; Tissue Temp: 19.8°C

Probe: ES3DV2 - SN3022; ConvF(5, 5, 5); Calibrated: 9/23/2003

Sensor-Surface: 3mm (Mechanical Surface Detection)

Electronics: DAE3 Sn445; Phantom: SAM 12b; Type: SAM 4.0; Serial: TP:1197

Measurement SW: DASY4, V4.2 Build 12; Postprocessing SW: SEMCAD, V1.8 Build 93

1900 MHz Dipole Validation

Area Scan (41x51x1): Measurement grid: dx=15mm, dy=15mm

Zoom Scan (7x7x7)/Cube 0: Measurement grid: dx=5mm, dy=5mm, dz=5mm

Input Power = 20.0 dBm (100 mW)

SAR(1 g) = 3.80 mW/g; SAR(10 g) = 1.91 mW/g

Target SAR(1g) = 3.97 mW/g; Deviation = -4.28 %

