



## SAR EVALUATION REPORT

**Applicant Name:**  
 Samsung Electronics, Co. Ltd.  
 129, Samsung-ro, Maetan dong,  
 Yeongtong-gu, Suwon-si  
 Gyeonggi-do 443-742, Korea

**Date of Testing:**  
 02/24/14 - 03/05/14  
**Test Site/Location:**  
 PCTEST Lab, Columbia, MD, USA  
**Document Serial No.:**  
 0Y1402240465.A3L

**FCC ID:** A3LSMV101M

**APPLICANT:** SAMSUNG ELECTRONICS, CO. LTD.

**DUT Type:** Portable Wireless Router  
**Application Type:** Certification  
**FCC Rule Part(s):** CFR §2.1093  
**Model(s):** SM-V101M



Equipment Class	Band & Mode	Tx Frequency	SAR
			1 gm Body (W/kg)
PCB	GPRS/EDGE Rx Only 850	824.20 - 848.80 MHz	0.72
PCB	UMTS 850	826.40 - 846.60 MHz	0.33
PCB	GPRS/EDGE Rx Only 1900	1850.20 - 1909.80 MHz	0.32
PCB	UMTS 1900	1852.4 - 1907.6 MHz	0.81
PCB	LTE Band 17	706.5 - 713.5 MHz	0.55
PCB	LTE Band 5 (Cell)	824.7 - 848.3 MHz	0.24
PCB	LTE Band 4 (AWS)	1710.7 - 1754.3 MHz	0.70
PCB	LTE Band 2 (PCS)	1850.7 - 1909.3 MHz	0.60
DTS	2.4 GHz WLAN	2412 - 2462 MHz	< 0.1
<b>Simultaneous SAR per KDB 690783 D01v01r02:</b>			0.88

This wireless portable device has been shown to be capable of compliance for localized specific absorption rate (SAR) for uncontrolled environment/general population exposure limits specified in ANSI/IEEE C95.1-1992 and has been tested in accordance with the measurement procedures specified in Section 1.7 of this report; for North American frequency bands only.

I attest to the accuracy of data. All measurements reported herein were performed by me or were made under my supervision and are correct to the best of my knowledge and belief. I assume full responsibility for the completeness of these measurements and vouch for the qualifications of all persons taking them. Test results reported herein relate only to the item(s) tested.



  
 Randy Ortanez  
 President



<b>FCC ID:</b> A3LSMV101M		<b>SAR EVALUATION REPORT</b>		<b>Reviewed by:</b> Quality Manager
<b>Document S/N:</b> 0Y1402240465.A3L	<b>Test Dates:</b> 02/24/14 - 03/05/14	<b>DUT Type:</b> Portable Wireless Router	Page 1 of 45	

# TABLE OF CONTENTS

1	DEVICE UNDER TEST .....	3
2	LTE INFORMATION.....	7
3	INTRODUCTION.....	8
4	DOSIMETRIC ASSESSMENT .....	9
5	SAR TESTING PROCEDURES .....	10
6	RF EXPOSURE LIMITS .....	11
7	FCC MEASUREMENT PROCEDURES.....	12
8	RF CONDUCTED POWERS.....	15
9	SYSTEM VERIFICATION.....	33
10	SAR DATA SUMMARY .....	35
11	FCC MULTI-TX AND ANTENNA SAR CONSIDERATIONS.....	38
12	SAR MEASUREMENT VARIABILITY .....	40
13	EQUIPMENT LIST.....	41
14	MEASUREMENT UNCERTAINTIES .....	42
15	CONCLUSION.....	43
16	REFERENCES .....	44
APPENDIX A: SAR TEST PLOTS		
APPENDIX B: SAR DIPOLE VERIFICATION PLOTS		
APPENDIX C: PROBE AND DIPOLE CALIBRATION CERTIFICATES		
APPENDIX D: SAR TISSUE SPECIFICATIONS		
APPENDIX E: SAR SYSTEM VALIDATION		
APPENDIX F: SAR TEST SETUP PHOTOGRAPHS		

<b>FCC ID:</b> A3LSMV101M		<b>SAR EVALUATION REPORT</b>		<b>Reviewed by:</b> Quality Manager
<b>Document S/N:</b> 0Y1402240465.A3L	<b>Test Dates:</b> 02/24/14 - 03/05/14	<b>DUT Type:</b> Portable Wireless Router		Page 2 of 45

# 1 DEVICE UNDER TEST



## 1.1 Device Overview

Band & Mode	Operating Modes	Tx Frequency
GPRS/EDGE Rx Only 850	Data	824.20 - 848.80 MHz
UMTS 850	Data	826.40 - 846.60 MHz
GPRS/EDGE Rx Only 1900	Data	1850.20 - 1909.80 MHz
UMTS 1900	Data	1852.4 - 1907.6 MHz
LTE Band 17	Data	706.5 - 713.5 MHz
LTE Band 5 (Cell)	Data	824.7 - 848.3 MHz
LTE Band 4 (AWS)	Data	1710.7 - 1754.3 MHz
LTE Band 2 (PCS)	Data	1850.7 - 1909.3 MHz
2.4 GHz WLAN	Data	2412 - 2462 MHz

## 1.2 Nominal and Maximum Output Power Specifications

This device operates using the following maximum and nominal output power specifications. SAR values were scaled to the maximum allowed power to determine compliance per KDB Publication 447498 D01v05r01.

Mode / Band		Burst Average GMSK (dBm)		
		1 TX Slots	2 TX Slots	
GPRS 850	Maximum	<b>32.5</b>	<b>29.5</b>	
	Nominal	<b>32.0</b>	<b>29.0</b>	
GPRS 1900	Maximum	<b>29.5</b>	<b>26.5</b>	
	Nominal	<b>29.0</b>	<b>26.0</b>	
Mode / Band		Modulated Average (dBm)		
		3GPP RMC Rel 99	3GPP HSDPA Rel 5	3GPP HSUPA Rel 6
UMTS Band 5 (850 MHz)	Maximum	<b>23.0</b>	<b>22.5</b>	<b>22.5</b>
	Nominal	<b>22.5</b>	<b>22.0</b>	<b>22.0</b>
UMTS Band 2 (1900 MHz)	Maximum	<b>23.0</b>	<b>22.5</b>	<b>22.5</b>
	Nominal	<b>22.5</b>	<b>22.0</b>	<b>22.0</b>
Mode / Band		Modulated Average (dBm)		
LTE Band 17	Maximum	<b>23.0</b>		
	Nominal	<b>22.5</b>		
LTE Band 5 (Cell)	Maximum	<b>23.0</b>		
	Nominal	<b>22.5</b>		
LTE Band 4 (AWS)	Maximum	<b>22.5</b>		
	Nominal	<b>22.0</b>		
LTE Band 2 (PCS)	Maximum	<b>22.5</b>		
	Nominal	<b>22.0</b>		

FCC ID: A3LSMV101M		SAR EVALUATION REPORT		Reviewed by: Quality Manager
Document S/N: OY1402240465.A3L	Test Dates: 02/24/14 - 03/05/14	DUT Type: Portable Wireless Router	Page 3 of 45	

Mode / Band		Modulated Average (dBm)
IEEE 802.11b (2.4 GHz)	Maximum	17.5
	Nominal	17.0
IEEE 802.11g (2.4 GHz)	Maximum	14.5
	Nominal	14.0
IEEE 802.11n (2.4 GHz)	Maximum	12.5
	Nominal	12.0

### 1.3 DUT Antenna Locations

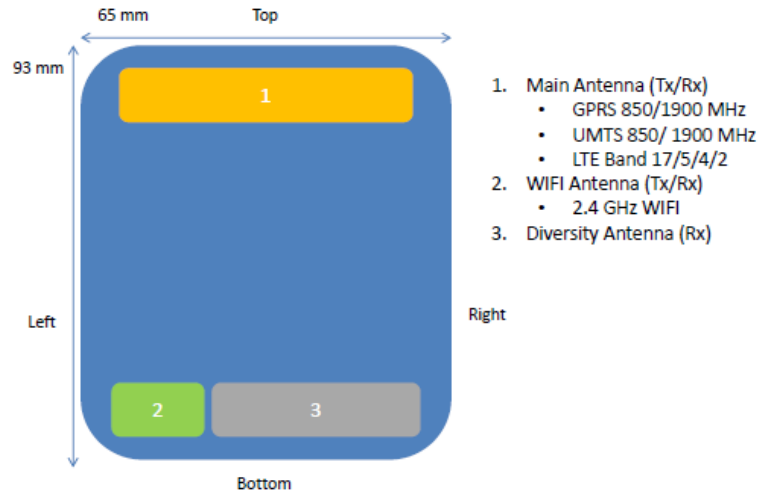

Note: Exact antenna dimensions and separation distances are shown in the Technical Descriptions.

**Figure 1-1**  
**DUT Antenna Locations**

**Table 1-1**  
**Sides for SAR Testing**

Sides for SAR Testing						
Band/Mode	Back	Front	Top	Bottom	Right	Left
GPRS 850	Yes	Yes	Yes	No	Yes	Yes
UMTS 850	Yes	Yes	Yes	No	Yes	Yes
GPRS 1900	Yes	Yes	Yes	No	Yes	Yes
UMTS 1900	Yes	Yes	Yes	No	Yes	Yes
LTE Band 17	Yes	Yes	Yes	No	Yes	Yes
LTE Band 5 (Cell)	Yes	Yes	Yes	No	Yes	Yes
LTE Band 4 (AWS)	Yes	Yes	Yes	No	Yes	Yes
LTE Band 2 (PCS)	Yes	Yes	Yes	No	Yes	Yes
2.4 GHz WLAN	Yes	Yes	No	Yes	No	Yes

Note: Particular DUT edges are not required to be evaluated for Wireless Router SAR if the edges were greater than 2.5 cm from the transmitting antenna according to FCC KDB Publication 941225 D06v01r01 guidance, page 2.

FCC ID: A3LSMV101M	PCTEST ENGINEERING LABORATORY, INC.	SAR EVALUATION REPORT	SAMSUNG	Reviewed by: Quality Manager
Document S/N: OY1402240465.A3L	Test Dates: 02/24/14 - 03/05/14	DUT Type: Portable Wireless Router	Page 4 of 45	

## 1.4 Simultaneous Transmission Capabilities

According to FCC KDB Publication 447498 D05v01r01, transmitters are considered to be transmitting simultaneously when there is overlapping transmission, with the exception of transmissions during network hand-offs with maximum hand-off duration less than 30 seconds. Possible transmission paths for the DUT are shown in Figure 1-2 and are color-coded to indicate communication modes which share the same path. Modes which share the same transmission path cannot transmit simultaneously with one another.

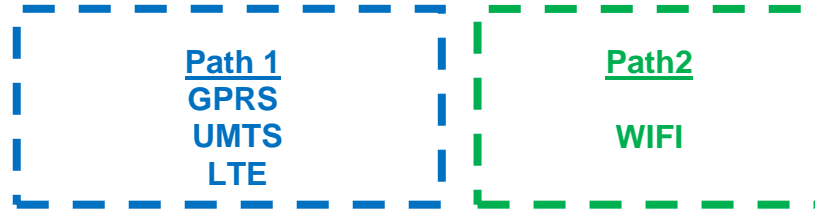

**Figure 1-2**  
**Simultaneous Transmission Paths**

This device contains multiple transmitters that may operate simultaneously, and therefore requires a simultaneous transmission analysis according to FCC KDB Publication 447498 D01v05r01 3) procedures.

**Table 1-2**  
**Simultaneous Transmission Scenarios**

No.	Capable Transmit Configuration	Body
1	UMTS + 2.4 GHz WI-FI	Yes
2	LTE + 2.4 GHz WI-FI	Yes
3	GPRS + 2.4 GHz WI-FI	Yes

Note: GPRS, UMTS, LTE share the same antenna and cannot transmit simultaneously.

## 1.5 SAR Test Exclusions Applied

### (A) WIFI

IEEE 802.11g/n was not evaluated for SAR since the average output power was not more than 0.25 dB higher than the average output power of IEEE 802.11b.



### (B) Licensed Transmitter(s)

This device is only capable of QPSK HSUPA in the uplink. Therefore, no additional SAR tests are required beyond that described for devices with HSUPA in KDB 941225 D01v02r02.

LTE SAR for the higher modulations and lower bandwidths were not tested since the maximum average output power of all required channels and configurations was not more than 0.5 dB higher than the highest bandwidth; and the reported LTE SAR for the highest bandwidth was less than 1.45 W/kg for all configurations according to FCC KDB 941225 D05v02r02.

## 1.6 Power Reduction for SAR

There is no power reduction used for any band/mode implemented in this device for SAR purposes.

FCC ID: A3LSMV101M		SAR EVALUATION REPORT		Reviewed by: Quality Manager
Document S/N: 0Y1402240465.A3L	Test Dates: 02/24/14 - 03/05/14	DUT Type: Portable Wireless Router		Page 5 of 45



## 1.7 Guidance Applied

- FCC KDB Publication 941225 D01-D06 (2G/3G/4G and Hotspot)
- FCC KDB Publication 248227 D01v01r02 (SAR Considerations for 802.11 Devices)
- FCC KDB Publication 447498 D01v05r01 (General SAR Guidance)
- FCC KDB Publication 865664 D01-D02 (SAR Measurements up to 6 GHz)
- October 2013 TCB Workshop Notes (GPRS Testing)

## 1.8 Device Serial Numbers

Several samples were used with identical hardware to support SAR testing. The manufacturer has confirmed that the device(s) tested have the same physical, mechanical and thermal characteristics and are within operational tolerances expected for production units.



Band and Mode	Body Serial
GPRS/EDGE Rx Only 850	1902-1
UMTS 850	1902-2
GPRS/EDGE Rx Only 1900	1902-1
UMTS 1900	1902-2
LTE Band 17	1902-3
LTE Band 5 (Cell)	1902-3
LTE Band 4 (AWS)	1902-1
LTE Band 2 (PCS)	1902-1
2.4 GHz WLAN	1902-3

FCC ID: A3LSMV101M	 <b>PCTEST</b> ENGINEERING LABORATORY, INC.	<b>SAR EVALUATION REPORT</b>		<b>Reviewed by:</b> Quality Manager
<b>Document S/N:</b> 0Y1402240465.A3L	<b>Test Dates:</b> 02/24/14 - 03/05/14	<b>DUT Type:</b> Portable Wireless Router	Page 6 of 45	

## 2

## LTE INFORMATION

LTE Information			
<b>FCC ID</b>	<b>A3LSMV101M</b>		
Form Factor	Portable Handset		
Frequency Range of each LTE transmission band	LTE Band 17 (706.5 - 713.5 MHz)		
	LTE Band 5 (Cell) (824.7 - 848.3 MHz)		
	LTE Band 4 (AWS) (1710.7 - 1754.3 MHz)		
	LTE Band 2 (PCS) (1850.7 - 1909.3 MHz)		
Channel Bandwidths	LTE Band 17: 5 MHz, 10 MHz		
	LTE Band 5 (Cell): 1.4 MHz, 3 MHz, 5 MHz, 10 MHz		
	LTE Band 4 (AWS): 1.4 MHz, 3 MHz, 5 MHz, 10 MHz, 15 MHz, 20 MHz		
	LTE Band 2 (PCS): 1.4 MHz, 3 MHz, 5 MHz, 10 MHz, 15 MHz, 20 MHz		
Channel Numbers and Frequencies (MHz)	Low	Mid	High
LTE Band 17: 5 MHz	706.5 (23755)	710 (23790)	713.5 (23825)
LTE Band 17: 10 MHz	709 (23780)	710 (23790)	711 (23800)
LTE Band 5 (Cell): 1.4 MHz	824.7 (20407)	836.5 (20525)	848.3 (20643)
LTE Band 5 (Cell): 3 MHz	825.5 (20415)	836.5 (20525)	847.5 (20635)
LTE Band 5 (Cell): 5 MHz	826.5 (20425)	836.5 (20525)	846.5 (20625)
LTE Band 5 (Cell): 10 MHz	829 (20450)	836.5 (20525)	844 (20600)
LTE Band 4 (AWS): 1.4 MHz	1710.7 (19957)	1732.5 (20175)	1754.3 (20393)
LTE Band 4 (AWS): 3 MHz	1711.5 (19965)	1732.5 (20175)	1753.5 (20385)
LTE Band 4 (AWS): 5 MHz	1712.5 (19975)	1732.5 (20175)	1752.5 (20375)
LTE Band 4 (AWS): 10 MHz	1715 (20000)	1732.5 (20175)	1750 (20350)
LTE Band 4 (AWS): 15 MHz	1717.5 (20025)	1732.5 (20175)	1747.5 (20325)
LTE Band 4 (AWS): 20 MHz	1720 (20050)	1732.5 (20175)	1745 (20300)
LTE Band 2 (PCS): 1.4 MHz	1850.7 (18607)	1880 (18900)	1909.3 (19193)
LTE Band 2 (PCS): 3 MHz	1851.5 (18615)	1880 (18900)	1908.5 (19185)
LTE Band 2 (PCS): 5 MHz	1852.5 (18625)	1880 (18900)	1907.5 (19175)
LTE Band 2 (PCS): 10 MHz	1855 (18650)	1880 (18900)	1905 (19150)
LTE Band 2 (PCS): 15 MHz	1857.5 (18675)	1880 (18900)	1902.5 (19125)
LTE Band 2 (PCS): 20 MHz	1860 (18700)	1880 (18900)	1900 (19100)
UE Category	3		
Modulations Supported in UL	QPSK, 16QAM		
LTE MPR Permanently implemented per 3GPP TS 36.101 section 6.2.3-6.2.5? (manufacturer attestation to be provided)	YES		
A-MPR (Additional MPR) disabled for SAR Testing?	YES		

FCC ID: A3LSMV101M		<b>SAR EVALUATION REPORT</b>		<b>Reviewed by:</b> Quality Manager
<b>Document S/N:</b> OY1402240465.A3L	<b>Test Dates:</b> 02/24/14 - 03/05/14	<b>DUT Type:</b> Portable Wireless Router	Page 7 of 45	

### 3 INTRODUCTION

The FCC and Industry Canada have adopted the guidelines for evaluating the environmental effects of radio frequency (RF) radiation in ET Docket 93-62 on Aug. 6, 1996 and Health Canada Safety Code 6 to protect the public and workers from the potential hazards of RF emissions due to FCC-regulated portable devices. [1]

The safety limits used for the environmental evaluation measurements are based on the criteria published by the American National Standards Institute (ANSI) for localized specific absorption rate (SAR) in IEEE/ANSI C95.1-1992 Standard for Safety Levels with Respect to Human Exposure to Radio Frequency Electromagnetic Fields, 3 kHz to 300 GHz [3] and Health Canada RF Exposure Guidelines Safety Code 6 [24]. The measurement procedure described in IEEE/ANSI C95.3-2002 Recommended Practice for the Measurement of Potentially Hazardous Electromagnetic Fields - RF and Microwave [4] is used for guidance in measuring the Specific Absorption Rate (SAR) due to the RF radiation exposure from the Equipment Under Test (EUT). These criteria for SAR evaluation are similar to those recommended by the International Committee for Non-Ionizing Radiation Protection (ICNIRP) in Biological Effects and Exposure Criteria for Radiofrequency Electromagnetic Fields,” Report No. Vol 74. SAR is a measure of the rate of energy absorption due to exposure to an RF transmitting source. SAR values have been related to threshold levels for potential biological hazards.

#### 3.1 SAR Definition

Specific Absorption Rate is defined as the time derivative (rate) of the incremental energy (dU) absorbed by (dissipated in) an incremental mass (dm) contained in a volume element (dV) of a given density ( $\rho$ ). It is also defined as the rate of RF energy absorption per unit mass at a point in an absorbing body (see Equation 3-1).

Equation 3-1  
SAR Mathematical Equation

$$SAR = \frac{d}{dt} \left( \frac{dU}{dm} \right) = \frac{d}{dt} \left( \frac{dU}{\rho dv} \right)$$



SAR is expressed in units of Watts per Kilogram (W/kg).

$$SAR = \frac{\sigma \cdot E^2}{\rho}$$

where:

- $\sigma$  = conductivity of the tissue-simulating material (S/m)
- $\rho$  = mass density of the tissue-simulating material (kg/m<sup>3</sup>)
- E = Total RMS electric field strength (V/m)

NOTE: The primary factors that control rate of energy absorption were found to be the wavelength of the incident field in relation to the dimensions and geometry of the irradiated organism, the orientation of the organism in relation to the polarity of field vectors, the presence of reflecting surfaces, and whether conductive contact is made by the organism with a ground plane.[6]

FCC ID: A3LSMV101M	 PCTEST ENGINEERING LABORATORY, INC.	SAR EVALUATION REPORT		Reviewed by: Quality Manager
Document S/N: 0Y1402240465.A3L	Test Dates: 02/24/14 - 03/05/14	DUT Type: Portable Wireless Router	Page 8 of 45	

## 4 DOSIMETRIC ASSESSMENT

### 4.1 Measurement Procedure

The evaluation was performed using the following procedure:

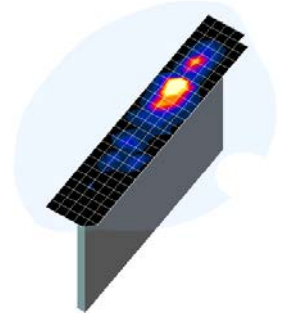

1. The SAR distribution at the exposed side of the head or body was measured at a distance no greater than 5.0 mm from the inner surface of the shell. The area covered the entire dimension of the device-head and body interface and the horizontal grid resolution was determined per FCC KDB Publication 865664 D01v01r01 (See Table 4-1).
2. The point SAR measurement was taken at the maximum SAR region determined from Step 1 to enable the monitoring of SAR fluctuations/drifts during the 1g/10g cube evaluation. SAR at this fixed point was measured and used as a reference value.
3. Based on the area scan data, the peak of the region with maximum SAR was determined by spline interpolation. Around this point, a volume was assessed according to the measurement resolution and volume size requirements of FCC KDB Publication 865664 D01v01r01 (See Table 4-1). On the basis of this data set, the spatial peak SAR value was evaluated with the following procedure (see references or the DASYS manual online for more details):
  - a. The data was extrapolated to the surface of the outer-shell of the phantom. The combined distance extrapolated was the combined distance from the center of the dipoles 2.7mm away from the tip of the probe housing plus the 1.2 mm distance between the surface and the lowest measuring point. The extrapolation was based on a least-squares algorithm. A polynomial of the fourth order was calculated through the points in the z-axis (normal to the phantom shell).
  - b. After the maximum interpolated values were calculated between the points in the cube, the SAR was averaged over the spatial volume (1g or 10g) using a 3D-Spline interpolation algorithm. The 3D-spline is composed of three one-dimensional splines with the "Not a knot" condition (in x, y, and z directions). The volume was then integrated with the trapezoidal algorithm. One thousand points (10 x 10 x 10) were obtained through interpolation, in order to calculate the averaged SAR.
  - c. All neighboring volumes were evaluated until no neighboring volume with a higher average value was found.
4. The SAR reference value, at the same location as step 2, was re-measured after the zoom scan was complete to calculate the SAR drift. If the drift deviated by more than 5%, the SAR test and drift measurements were repeated.



**Figure 4-1**  
**Sample SAR Area Scan**

**Table 4-1**  
**Area and Zoom Scan Resolutions per FCC KDB Publication 865664 D01v01r01**

Frequency	Maximum Area Scan Resolution (mm) ( $\Delta x_{area}, \Delta y_{area}$ )	Maximum Zoom Scan Resolution (mm) ( $\Delta x_{zoom}, \Delta y_{zoom}$ )	Maximum Zoom Scan Spatial Resolution (mm)			Minimum Zoom Scan Volume (mm) (x, y, z)
			Uniform Grid	Graded Grid		
			$\Delta z_{zoom}(n)$	$\Delta z_{zoom}(1)^*$	$\Delta z_{zoom}(n>1)^*$	
≤ 2 GHz	≤ 15	≤ 8	≤ 5	≤ 4	≤ 1.5* $\Delta z_{zoom}(n-1)$	≥ 30
2-3 GHz	≤ 12	≤ 5	≤ 5	≤ 4	≤ 1.5* $\Delta z_{zoom}(n-1)$	≥ 30
3-4 GHz	≤ 12	≤ 5	≤ 4	≤ 3	≤ 1.5* $\Delta z_{zoom}(n-1)$	≥ 28
4-5 GHz	≤ 10	≤ 4	≤ 3	≤ 2.5	≤ 1.5* $\Delta z_{zoom}(n-1)$	≥ 25
5-6 GHz	≤ 10	≤ 4	≤ 2	≤ 2	≤ 1.5* $\Delta z_{zoom}(n-1)$	≥ 22

FCC ID: A3LSMV101M		SAR EVALUATION REPORT		Reviewed by: Quality Manager
Document S/N: OY1402240465.A3L	Test Dates: 02/24/14 - 03/05/14	DUT Type: Portable Wireless Router		Page 9 of 45

## 5 SAR TESTING PROCEDURES



### 5.1 Device Holder

The device holder is made out of low-loss POM material having the following dielectric parameters: relative permittivity  $\epsilon = 3$  and loss tangent  $\delta = 0.02$ .

### 5.2 Wireless Router Configurations

Some battery-operated devices have the capability to transmit and receive user data through simultaneous transmission of WIFI simultaneously with a separate licensed transmitter. The FCC has provided guidance in FCC KDB Publication 941225 D06v01r01 where SAR test considerations for devices ( $L \times W \geq 9 \text{ cm} \times 5 \text{ cm}$ ) are based on a composite test separation distance of 10 mm from the front, back and edges of the device containing transmitting antennas within 2.5 cm of their edges, determined from general mixed use conditions for this type of devices. Since the device meets the given size constraints, the aforementioned procedure was followed for SAR testing.

This device operates using simultaneous transmission of both the WIFI transmitter and another licensed transmitter. Both transmitters often do not transmit at the same transmitting frequency and thus cannot be evaluated for SAR under actual use conditions due to the limitations of the SAR assessment probes. Therefore, SAR must be evaluated for each frequency transmission and mode separately and spatially summed with the WIFI transmitter according to FCC KDB Publication 447498 D01v05r01 publication procedures.

FCC ID: A3LSMV101M		SAR EVALUATION REPORT		Reviewed by: Quality Manager
Document S/N: 0Y1402240465.A3L	Test Dates: 02/24/14 - 03/05/14	DUT Type: Portable Wireless Router	Page 10 of 45	

# 6 RF EXPOSURE LIMITS

## 6.1 Uncontrolled Environment

UNCONTROLLED ENVIRONMENTS are defined as locations where there is the exposure of individuals who have no knowledge or control of their exposure. The general population/uncontrolled exposure limits are applicable to situations in which the general public may be exposed or in which persons who are exposed as a consequence of their employment may not be made fully aware of the potential for exposure or cannot exercise control over their exposure. Members of the general public would come under this category when exposure is not employment-related; for example, in the case of a wireless transmitter that exposes persons in its vicinity.



## 6.2 Controlled Environment

CONTROLLED ENVIRONMENTS are defined as locations where there is exposure that may be incurred by persons who are aware of the potential for exposure, (i.e. as a result of employment or occupation). In general, occupational/controlled exposure limits are applicable to situations in which persons are exposed as a consequence of their employment, who have been made fully aware of the potential for exposure and can exercise control over their exposure. This exposure category is also applicable when the exposure is of a transient nature due to incidental passage through a location where the exposure levels may be higher than the general population/uncontrolled limits, but the exposed person is fully aware of the potential for exposure and can exercise control over his or her exposure by leaving the area or by some other appropriate means.

**Table 6-1**  
**SAR Human Exposure Specified in ANSI/IEEE C95.1-1992 and Health Canada Safety Code 6**

HUMAN EXPOSURE LIMITS		
	UNCONTROLLED ENVIRONMENT <i>General Population</i> (W/kg) or (mW/g)	CONTROLLED ENVIRONMENT <i>Occupational</i> (W/kg) or (mW/g)
<b>Peak Spatial Average SAR</b> Head	1.6	8.0
<b>Whole Body SAR</b>	0.08	0.4
<b>Peak Spatial Average SAR</b> Hands, Feet, Ankle, Wrists, etc.	4.0	20

1. The Spatial Peak value of the SAR averaged over any 1 gram of tissue (defined as a tissue volume in the shape of a cube) and over the appropriate averaging time.
2. The Spatial Average value of the SAR averaged over the whole body.
3. The Spatial Peak value of the SAR averaged over any 10 grams of tissue (defined as a tissue volume in the shape of a cube) and over the appropriate averaging time.

FCC ID: A3LSMV101M	 PCTEST ENGINEERING LABORATORY, INC.	SAR EVALUATION REPORT	 SAMSUNG	Reviewed by: Quality Manager
Document S/N: 0Y1402240465.A3L	Test Dates: 02/24/14 - 03/05/14	DUT Type: Portable Wireless Router	Page 11 of 45	

# 7 FCC MEASUREMENT PROCEDURES

## 7.1 Measured and Reported SAR

Per FCC KDB Publication 447498 D01v05r01, When SAR is not measured at the maximum power level allowed for production units, the results must be scaled to the maximum tune-up tolerance limit according to the power applied to the individual channels tested to determine compliance. For simultaneous transmission, the measured aggregate SAR must be scaled according to the sum of the differences between the maximum tune-up tolerance and actual power used to test each transmitter. When SAR is measured at or scaled to the maximum tune-up tolerance limit, the results are referred to as *reported* SAR. The highest *reported* SAR results are identified on the grant of equipment authorization according to procedures in KDB 690783 D01v01r02.

## 7.2 Procedures Used to Establish RF Signal for SAR

The following procedures are according to FCC KDB Publication 941225 D01 "SAR Measurement Procedures for 3G Devices" v02r02, October 2007.

The device was placed into a simulated call using a base station simulator in a RF shielded chamber. Establishing connections in this manner ensure a consistent means for testing SAR and are recommended for evaluating SAR [4]. Devices under test were evaluated prior to testing, with a fully charged battery and were configured to operate at maximum output power. In order to verify that the device was tested throughout the SAR test at maximum output power, the SAR measurement system measures a "point SAR" at an arbitrary reference point at the start and end of the 1 gram SAR evaluation, to assess for any power drifts during the evaluation. If the power drift deviated by more than 5%, the SAR test and drift measurements were repeated.

## 7.3 SAR Measurement Conditions for UMTS

### 7.3.1 Output Power Verification

Maximum output power is measured on the High, Middle and Low channels for each applicable transmission band according to the general descriptions in section 5.2 of 3GPP TS 34.121, using the appropriate RMC or AMR with TPC (transmit power control) set to all "1s".



Maximum output power is verified on the High, Middle and Low channels according to the general descriptions in section 5.2 of 3GPP TS 34.121 (release 5), using the appropriate RMC with TPC (transmit power control) set to all "1s" or applying the required inner loop power control procedures to maintain maximum output power while HSUPA is active. Results for all applicable physical channel configurations (DPCCH, DPDCHn and spreading codes, HS-DPCCH etc) are tabulated in this test report. All configurations that are not supported by the DUT or cannot be measured due to technical or equipment limitations are identified.

### 7.3.2 Body SAR Measurements

SAR for body exposure configurations is measured using the 12.2 kbps RMC with the TPC bits all "1s".

### 7.3.3 Procedures Used to Establish RF Signal for SAR HSDPA Data Devices

The following procedures are applicable to HSDPA data devices operating under 3GPP Release 5. Body exposure conditions are typically applicable to these devices, including handsets and data modems operating in various electronic devices. HSDPA operates in conjunction with UMTS and requires an active DPCCH. The default test configuration is to measure SAR in UMTS without HSDPA, with an established radio link between the DUT and a communication test set with 12.2 kbps RMC mode configured in Test Loop Mode 1; and tested with HSDPA with FRC and a 12.2 kbps RMC using the highest SAR configuration in UMTS. SAR is selectively confirmed for other physical channel configurations according to output power, exposure conditions and device operating capabilities. Maximum output power is verified according to 3GPP TS 23.121 (Release 5) and SAR must be measured according to these maximum output conditions.

FCC ID: A3LSMV101M		SAR EVALUATION REPORT		Reviewed by: Quality Manager
Document S/N: 0Y1402240465.A3L	Test Dates: 02/24/14 - 03/05/14	DUT Type: Portable Wireless Router		Page 12 of 45

Sub-Test	$\beta_c$	$\beta_d$	$\beta_d$ (SF)	$\beta_c/\beta_d$	$\beta_{HS}$ (Note 1, Note 2)	CM (dB) (Note 3)	MPR (dB) (Note 3)
1	2/15	15/15	64	2/15	4/15	0.0	0.0
2	12/15 (Note 4)	15/15 (Note 4)	64	12/15 (Note 4)	24/15	1.0	0.0
3	15/15	8/15	64	15/8	30/15	1.5	0.5
4	15/15	4/15	64	15/4	30/15	1.5	0.5

Note 1:  $\Delta_{ACK}$ ,  $\Delta_{NACK}$  and  $\Delta_{CQI} = 8 \Leftrightarrow A_{HS} = \beta_{HS}/\beta_c = 30/15 \Leftrightarrow \beta_{HS} = 30/15 * \beta_c$ .  
Note 2: For the HS-DPCCH power mask requirement test in clause 5.2C, 5.7A, and the Error Vector Magnitude (EVM) with HS-DPCCH test in clause 5.13.1A, and HSDPA EVM with phase discontinuity in clause 5.13.1AA,  $\Delta_{ACK}$  and  $\Delta_{NACK} = 8$  ( $A_{HS} = 30/15$ ) with  $\beta_{HS} = 30/15 * \beta_c$ , and  $\Delta_{CQI} = 7$  ( $A_{HS} = 24/15$ ) with  $\beta_{HS} = 24/15 * \beta_c$ .  
Note 3: CM = 1 for  $\beta_c/\beta_d = 12/15$ ,  $\beta_{HS}/\beta_c = 24/15$ . For all other combinations of DPDCH, DPCCH and HS-DPCCH the MPR is based on the relative CM difference. This is applicable for only UEs that support HSDPA in release 6 and later releases.

Figure 7-1  
Table C.10.1.4 of TS 234.121-1

### 7.3.4 SAR Measurement Conditions for HSUPA Data Devices

SAR for body exposure configurations are measured according to the 'Body SAR Measurements' procedures in the 'WCDMA Handsets' section of the KDB 941225 D01v02r02 FCC 3G document. In addition, Body SAR is also measured for HSPA when the maximum average output of each RF channel with HSPA active is at least ¼ dB higher of that measured without HSPA in 12.2 kbps RMC mode or the maximum SAR for 12.2 kbps RMC is above 75% of the SAR limit. Body SAR for HSPA is measured with E-DCH Sub-test 5, using H-Set 1 and QPSK for FRC and a 12.2 kbps RMC configured in Test Loop Mode 1 with power control algorithm 2, according to the highest body SAR configuration in 12.2 kbps RMC without HSPA. When VOIP is applicable for head exposure, SAR is not required when the maximum output of each RF channel with HSPA is less than ¼ dB higher than that measured using 12.2 kbps RMC; otherwise, the same HSPA configuration used for body measurements should be used to test for head exposure.

Due to inner loop power control requirements in HSPA, a commercial communication test set should be used for the output power and SAR tests. The 12.2 kbps RMC, FRC H-set 1 and EDCH configurations for HSPA should be configured according to the  $\beta$  values indicated below as well as other applicable procedures described in the 'WCDMA Handset' and 'Release 5 HSDPA Data Devices' sections of the FCC 3G document.

Sub-test	$\beta_c$	$\beta_d$	$\beta_d$ (SF)	$\beta_c/\beta_d$	$\beta_{HS}^{(1)}$	$\beta_{ec}$	$\beta_{ed}$	$\beta_{ed}$ (SF)	$\beta_{ed}$ (codes)	CM <sup>(2)</sup> (dB)	MPR (dB)	AG <sup>(4)</sup> Index	E-TFC
1	11/15 <sup>(3)</sup>	15/15 <sup>(3)</sup>	64	11/15 <sup>(3)</sup>	22/15	209/225	1039/225	4	1	1.0	0.0	20	75
2	6/15	15/15	64	6/15	12/15	12/15	94/75	4	1	3.0	2.0	12	67
3	15/15	9/15	64	15/9	30/15	30/15	$\beta_{ed1}: 47/15$ $\beta_{ed2}: 47/15$	4	2	2.0	1.0	15	92
4	2/15	15/15	64	2/15	4/15	2/15	56/75	4	1	3.0	2.0	17	71
5	15/15 <sup>(4)</sup>	15/15 <sup>(4)</sup>	64	15/15 <sup>(4)</sup>	30/15	24/15	134/15	4	1	1.0	0.0	21	81



Note 1:  $\Delta_{ACK}$ ,  $\Delta_{NACK}$  and  $\Delta_{CQI} = 8 \Leftrightarrow A_{HS} = \beta_{HS}/\beta_c = 30/15 \Leftrightarrow \beta_{HS} = 30/15 * \beta_c$ .  
Note 2: CM = 1 for  $\beta_c/\beta_d = 12/15$ ,  $\beta_{HS}/\beta_c = 24/15$ . For all other combinations of DPDCH, DPCCH, HS-DPCCH, E-DPCCH and E-DPCCH the MPR is based on the relative CM difference.  
Note 3: For subtest 1 the  $\beta_c/\beta_d$  ratio of 11/15 for the TFC during the measurement period (TF1, TF0) is achieved by setting the signaled gain factors for the reference TFC (TF1, TF1) to  $\beta_c = 10/15$  and  $\beta_d = 15/15$ .  
Note 4: For subtest 5 the  $\beta_c/\beta_d$  ratio of 15/15 for the TFC during the measurement period (TF1, TF0) is achieved by setting the signaled gain factors for the reference TFC (TF1, TF1) to  $\beta_c = 14/15$  and  $\beta_d = 15/15$ .  
Note 5: Testing UE using E-DPCCH Physical Layer category 1 Sub-test 3 is not required according to TS 25.306 Table 5.1g.  
Note 6:  $\beta_{ed}$  can not be set directly; it is set by Absolute Grant Value.

### 7.4 SAR Measurement Conditions for LTE

LTE modes were tested according to FCC KDB 941225 D05v02r02 publication. Please see notes after the tabulated SAR data for required test configurations. Establishing connections with base station simulators ensure a consistent means for testing SAR and are recommended for evaluating SAR [4]. The R&S CMW500 was used for LTE output power measurements and SAR testing. Closed loop power control was used so the UE transmits with maximum output power during SAR testing.

#### 7.4.1 Spectrum Plots for RB Configurations

A properly configured base station simulator was used for SAR tests and power measurements. Therefore, spectrum plots for RB configurations were not required to be included in this report.

FCC ID: A3LSMV101M		SAR EVALUATION REPORT		Reviewed by: Quality Manager
Document S/N: OY1402240465.A3L	Test Dates: 02/24/14 - 03/05/14	DUT Type: Portable Wireless Router		Page 13 of 45

## 7.4.2 MPR

MPR is permanently implemented for this device by the manufacturer. The specific manufacturer target MPR is indicated alongside the SAR results. MPR is enabled for this device, according to 3GPP TS36.101 Section 6.2.3 – 6.2.5 under Table 6.2.3-1.

## 7.4.3 A-MPR

A-MPR (Additional MPR) has been disabled for all SAR tests by setting NS=01 on the base station simulator.

## 7.4.4 Required RB Size and RB Offsets for SAR Testing

According to FCC KDB 941225 D05v02r02:

- a. Per Section 5.2.1, SAR is required for QPSK 1 RB Allocation for the largest bandwidth
  - i. The required channel and offset combination with the highest maximum output power is required for SAR.
  - ii. When the reported SAR is  $\leq 0.8$  W/kg, testing of the remaining RB offset configurations and required test channels is not required. Otherwise, SAR is required for the remaining required test channels using the RB offset configuration with highest output power for that channel.
  - iii. When the reported SAR for a required test channel is  $> 1.45$  W/kg, SAR is required for all RB offset configurations for that channel.
- b. Per Section 5.2.2, SAR is required for 50% RB allocation using the largest bandwidth following the same procedures outlined in Section 5.2.1.
- c. Per Section 5.2.3, QPSK SAR is not required for the 100% allocation when the highest maximum output power for the 100% allocation is less than the highest maximum output power of the 1 RB and 50% RB allocations and the reported SAR for the 1 RB and 50% RB allocations is  $< 0.8$  W/kg.
- d. Per Section 5.2.4 and 5.3, SAR tests for higher order modulations and lower bandwidths configurations are not required when the conducted power of the required test configurations determined by Sections 5.2.1 through 5.2.3 is less than or equal to  $\frac{1}{2}$  dB higher than the equivalent configuration using QPSK modulation and when the QPSK SAR for those configurations is  $< 1.45$  W/kg.

## 7.5 SAR Testing with 802.11 Transmitters

Normal network operating configurations are not suitable for measuring the SAR of 802.11 b/g/n transmitters. Unpredictable fluctuations in network traffic and antenna diversity conditions can introduce undesirable variations in SAR results. The SAR for these devices should be measured using chipset based test mode software to ensure the results are consistent and reliable. See KDB Publication 248227 D01v01r02 for more details.



### 7.5.1 General Device Setup

Chipset based test mode software is hardware dependent and generally varies among manufacturers. The device operating parameters established in test mode for SAR measurements must be identical to those programmed in production units, including output power levels, amplifier gain settings and other RF performance tuning parameters. The test frequencies should correspond to actual channel frequencies defined for domestic use. SAR for devices with switched diversity should be measured with only one antenna transmitting at a time during each SAR measurement, according to a fixed modulation and data rate. The same data pattern should be used for all measurements.

### 7.5.2 Frequency Channel Configurations [27]

For 2.4 GHz, the highest average RF output power channel between the low, mid and high channel at the lowest data rate was selected for SAR evaluation in 802.11b mode. 802.11g/n modes and higher data rates for 802.11b were additionally evaluated for SAR if the output power of the respective mode was 0.25 dB or higher than the powers of the SAR configurations tested in the 802.11b mode.

If the maximum extrapolated peak SAR of the zoom scan for the highest output channel was less than 1.6 W/kg and if the 1g averaged SAR was less than 0.8 W/kg, SAR testing was not required for the other test channels in the band.

FCC ID: A3LSMV101M		SAR EVALUATION REPORT		Reviewed by: Quality Manager
Document S/N: OY1402240465.A3L	Test Dates: 02/24/14 - 03/05/14	DUT Type: Portable Wireless Router		Page 14 of 45

# 8 RF CONDUCTED POWERS

## 8.1 GSM Conducted Powers

		Maximum Burst-Averaged Output Power	
		GPRS Data (GMSK)	
Band	Channel	GPRS [dBm] 1 Tx Slot	GPRS [dBm] 2 Tx Slot
GSM 850	128	31.77	28.88
	190	31.66	28.85
	251	32.22	29.34
GSM 1900	512	29.50	26.50
	661	29.48	26.44
	810	29.33	26.34
		Calculated Maximum Frame-Averaged Output Power	
		GPRS Data (GMSK)	
Band	Channel	GPRS [dBm] 1 Tx Slot	GPRS [dBm] 2 Tx Slot
GSM 850	128	22.74	22.86
	190	22.63	22.83
	251	23.19	23.32
GSM 1900	512	20.47	20.48
	661	20.45	20.42
	810	20.30	20.32
GSM 850	Frame Avg.	22.97	22.98
GSM 1900	Targets:	19.97	19.98

**Note:**

- Both burst-averaged and calculated frame-averaged powers are included. Frame-averaged power was calculated from the measured burst-averaged power by converting the slot powers into linear units and calculating the energy over 8 timeslots.
- Per October 2013 TCB Workshop notes, the source-based frame-averaged output power was evaluated for all GPRS slot configurations. The configuration with the highest target frame averaged output power was evaluated for hotspot SAR. When the maximum frame-averaged powers are equivalent across two or more slots (within 0.25 dB), the configuration with the most number of time slots was tested.
- GPRS (GMSK) output powers were measured with coding scheme setting of 1 (CS1) on the base station simulator. CS1 was configured to measure GPRS output power measurements and SAR to ensure GMSK modulation in the signal. Our investigation has shown that CS1 - CS4 settings do not have any impact on the output levels or modulation in the GPRS modes.

**GSM Class: C**  
**GPRS Multislot class: 10 (Max 2 Tx uplink slots)**  
**EDGE Multislot class: Rx Only**  
**DTM Multislot Class: N/A**

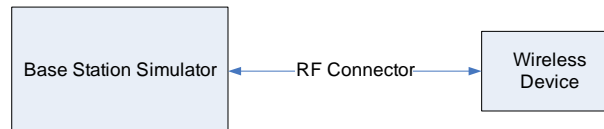

**Figure 8-1  
Power Measurement Setup**

FCC ID: A3LSMV101M		<b>SAR EVALUATION REPORT</b>		<b>Reviewed by:</b> Quality Manager
<b>Document S/N:</b> 0Y1402240465.A3L	<b>Test Dates:</b> 02/24/14 - 03/05/14	<b>DUT Type:</b> Portable Wireless Router	Page 15 of 45	

## 8.2 UMTS Conducted Powers

3GPP Release Version	Mode	3GPP 34.121 Subtest	Cellular Band [dBm]			PCS Band [dBm]			3GPP MPR [dB]
			4132	4183	4233	9262	9400	9538	
99	WCDMA	12.2 kbps RMC	22.41	22.42	22.33	21.97	22.05	22.03	-
6	HSDPA	Subtest 1	22.10	22.34	22.07	21.82	21.69	21.54	0
6		Subtest 2	22.05	22.21	22.14	21.88	21.75	21.50	0
6		Subtest 3	21.47	21.81	21.40	21.15	21.06	20.88	0.5
6		Subtest 4	21.39	21.52	21.32	21.09	21.01	20.92	0.5
6	HSUPA	Subtest 1	21.16	21.19	21.40	20.55	20.53	20.50	0
6		Subtest 2	19.75	19.98	19.58	19.32	19.25	19.33	2
6		Subtest 3	20.22	20.44	20.49	20.11	20.26	20.29	1
6		Subtest 4	19.57	19.65	19.69	19.39	19.22	19.31	2
6		Subtest 5	21.32	21.23	21.31	20.61	20.58	20.51	0



UMTS SAR was tested under RMC 12.2 kbps with HSPA Inactive per KDB Publication 941225 D01v02r02. HSPA SAR was not required since the average output power of the HSPA subtests was not more than 0.25 dB higher than the RMC level and SAR was less than 1.2 W/kg.

This device does not support DC-HSDPA.

It is expected by the manufacturer that MPR for some HSUPA subtests may be up to 2 dB more than specified by 3GPP, but also as low as 0 dB according to the chipset implementation in this model.



**Figure 8-2**  
**Power Measurement Setup**

FCC ID: A3LSMV101M		SAR EVALUATION REPORT		Reviewed by: Quality Manager
Document S/N: 0Y1402240465.A3L	Test Dates: 02/24/14 - 03/05/14	DUT Type: Portable Wireless Router	Page 16 of 45	

## 8.3 LTE Conducted Powers

### 8.3.1 LTE Band 17

**Table 8-1**  
**LTE Band 17 Conducted Powers - 10 MHz Bandwidth**



Frequency [MHz]	Channel	Bandwidth [MHz]	Modulation	RB Size	RB Offset	Conducted Power [dBm]	MPR Allowed per 3GPP [dB]	MPR [dB]
Mid	23790	10	QPSK	1	0	22.36	0	0
	23790	10	QPSK	1	25	22.69	0	0
	23790	10	QPSK	1	49	23.00	0	0
	23790	10	QPSK	25	0	21.65	0-1	1
	23790	10	QPSK	25	12	21.92	0-1	1
	23790	10	QPSK	25	25	21.80	0-1	1
	23790	10	QPSK	50	0	21.90	0-1	1
	23790	10	16QAM	1	0	21.66	0-1	1
	23790	10	16QAM	1	25	21.82	0-1	1
	23790	10	16QAM	1	49	22.00	0-1	1
	23790	10	16QAM	25	0	20.94	0-2	2
	23790	10	16QAM	25	12	20.99	0-2	2
	23790	10	16QAM	25	25	20.98	0-2	2
	23790	10	16QAM	50	0	20.87	0-2	2

Note: LTE Band 17 at 10 MHz bandwidth does not support three non-overlapping channels. Per KDB Publication 941225 D05v02r02, when a device supports overlapping channel assignment in a channel bandwidth configuration, the middle channel of the group of overlapping channels should be selected for testing.

**Table 8-2**  
**LTE Band 17 Conducted Powers - 5 MHz Bandwidth**

Frequency [MHz]	Channel	Bandwidth [MHz]	Modulation	RB Size	RB Offset	Conducted Power [dBm]	MPR Allowed per 3GPP [dB]	MPR [dB]
Mid	23790	5	QPSK	1	0	22.46	0	0
	23790	5	QPSK	1	12	22.79	0	0
	23790	5	QPSK	1	24	23.00	0	0
	23790	5	QPSK	12	0	21.55	0-1	1
	23790	5	QPSK	12	6	21.92	0-1	1
	23790	5	QPSK	12	13	21.80	0-1	1
	23790	5	QPSK	25	0	21.80	0-1	1
	23790	5	16-QAM	1	0	21.56	0-1	1
	23790	5	16-QAM	1	12	21.72	0-1	1
	23790	5	16-QAM	1	24	21.90	0-1	1
	23790	5	16-QAM	12	0	20.94	0-2	2
	23790	5	16-QAM	12	6	20.99	0-2	2
	23790	5	16-QAM	12	13	20.88	0-2	2
	23790	5	16-QAM	25	0	20.87	0-2	2

Note: LTE Band 17 at 5 MHz bandwidth does not support three non-overlapping channels. Per KDB Publication 941225 D05v02r02, when a device supports overlapping channel assignment in a channel bandwidth configuration, the middle channel of the group of overlapping channels should be selected for testing.

FCC ID: A3LSMV101M		<b>SAR EVALUATION REPORT</b>		Reviewed by: Quality Manager
Document S/N: OY1402240465.A3L	Test Dates: 02/24/14 - 03/05/14	DUT Type: Portable Wireless Router		Page 17 of 45

### 8.3.2 LTE Band 5 (Cell)



**Table 8-3**  
**LTE Band 5 (Cell) Conducted Powers - 10 MHz Bandwidth**

Frequency [MHz]	Channel	Bandwidth [MHz]	Modulation	RB Size	RB Offset	Conducted Power [dBm]	MPR Allowed per 3GPP [dB]	MPR [dB]
836.5	20525	10	QPSK	1	0	22.52	0	0
836.5	20525	10	QPSK	1	25	22.38	0	0
836.5	20525	10	QPSK	1	49	22.35	0	0
836.5	20525	10	QPSK	25	0	21.30	0-1	1
836.5	20525	10	QPSK	25	12	21.24	0-1	1
836.5	20525	10	QPSK	25	25	21.23	0-1	1
836.5	20525	10	QPSK	50	0	21.24	0-1	1
836.5	20525	10	16QAM	1	0	21.61	0-1	1
836.5	20525	10	16QAM	1	25	21.63	0-1	1
836.5	20525	10	16QAM	1	49	21.45	0-1	1
836.5	20525	10	16QAM	25	0	20.51	0-2	2
836.5	20525	10	16QAM	25	12	20.35	0-2	2
836.5	20525	10	16QAM	25	25	20.40	0-2	2
836.5	20525	10	16QAM	50	0	20.38	0-2	2

Note: LTE Band 5 at 10 MHz bandwidth does not support three non-overlapping channels. Per KDB Publication 941225 D05v02r02, when a device supports overlapping channel assignment in a channel bandwidth configuration, the middle channel of the group of overlapping channels should be selected for testing.



**Table 8-4**  
**LTE Band 5 (Cell) Conducted Powers - 5 MHz Bandwidth**

Frequency [MHz]	Channel	Bandwidth [MHz]	Modulation	RB Size	RB Offset	Conducted Power [dBm]	MPR Allowed per 3GPP [dB]	MPR [dB]
826.5	20425	5	QPSK	1	0	22.42	0	0
826.5	20425	5	QPSK	1	12	22.38	0	0
826.5	20425	5	QPSK	1	24	22.45	0	0
826.5	20425	5	QPSK	12	0	21.40	0-1	1
826.5	20425	5	QPSK	12	6	21.24	0-1	1
826.5	20425	5	QPSK	12	13	21.33	0-1	1
826.5	20425	5	QPSK	25	0	21.14	0-1	1
826.5	20425	5	16-QAM	1	0	21.61	0-1	1
826.5	20425	5	16-QAM	1	12	21.73	0-1	1
826.5	20425	5	16-QAM	1	24	21.55	0-1	1
826.5	20425	5	16-QAM	12	0	20.61	0-2	2
826.5	20425	5	16-QAM	12	6	20.35	0-2	2
826.5	20425	5	16-QAM	12	13	20.40	0-2	2
826.5	20425	5	16-QAM	25	0	20.48	0-2	2
836.5	20525	5	QPSK	1	0	22.52	0	0
836.5	20525	5	QPSK	1	12	22.38	0	0
836.5	20525	5	QPSK	1	24	22.45	0	0
836.5	20525	5	QPSK	12	0	21.30	0-1	1
836.5	20525	5	QPSK	12	6	21.34	0-1	1
836.5	20525	5	QPSK	12	13	21.33	0-1	1
836.5	20525	5	QPSK	25	0	21.34	0-1	1
836.5	20525	5	16-QAM	1	0	21.51	0-1	1
836.5	20525	5	16-QAM	1	12	21.53	0-1	1
836.5	20525	5	16-QAM	1	24	21.35	0-1	1
836.5	20525	5	16-QAM	12	0	20.51	0-2	2
836.5	20525	5	16-QAM	12	6	20.25	0-2	2
836.5	20525	5	16-QAM	12	13	20.40	0-2	2
836.5	20525	5	16-QAM	25	0	20.48	0-2	2
846.5	20625	5	QPSK	1	0	22.42	0	0
846.5	20625	5	QPSK	1	12	22.28	0	0
846.5	20625	5	QPSK	1	24	22.25	0	0
846.5	20625	5	QPSK	12	0	21.30	0-1	1
846.5	20625	5	QPSK	12	6	21.24	0-1	1
846.5	20625	5	QPSK	12	13	21.13	0-1	1
846.5	20625	5	QPSK	25	0	21.24	0-1	1
846.5	20625	5	16-QAM	1	0	21.71	0-1	1
846.5	20625	5	16-QAM	1	12	21.73	0-1	1
846.5	20625	5	16-QAM	1	24	21.55	0-1	1
846.5	20625	5	16-QAM	12	0	20.61	0-2	2
846.5	20625	5	16-QAM	12	6	20.35	0-2	2
846.5	20625	5	16-QAM	12	13	20.50	0-2	2
846.5	20625	5	16-QAM	25	0	20.28	0-2	2

FCC ID: A3LSMV101M	 PCTEST ENGINEERING LABORATORY, INC.	SAR EVALUATION REPORT	 SAMSUNG	Reviewed by: Quality Manager
Document S/N: OY1402240465.A3L	Test Dates: 02/24/14 - 03/05/14	DUT Type: Portable Wireless Router		Page 18 of 45



**Table 8-5  
LTE Band 5 (Cell) Conducted Powers - 3 MHz Bandwidth**

	Frequency [MHz]	Channel	Bandwidth [MHz]	Modulation	RB Size	RB Offset	Conducted Power [dBm]	MPR Allowed per 3GPP [dB]	MPR [dB]
Low	825.5	20415	3	QPSK	1	0	22.32	0	0
	825.5	20415	3	QPSK	1	7	22.28	0	0
	825.5	20415	3	QPSK	1	14	22.35	0	0
	825.5	20415	3	QPSK	8	0	21.30	0-1	1
	825.5	20415	3	QPSK	8	4	21.14	0-1	1
	825.5	20415	3	QPSK	8	7	21.23	0-1	1
	825.5	20415	3	QPSK	15	0	21.24	0-1	1
	825.5	20415	3	16-QAM	1	0	21.61	0-1	1
	825.5	20415	3	16-QAM	1	7	21.83	0-1	1
	825.5	20415	3	16-QAM	1	14	21.65	0-1	1
	825.5	20415	3	16-QAM	8	0	20.71	0-2	2
	825.5	20415	3	16-QAM	8	4	20.45	0-2	2
	825.5	20415	3	16-QAM	8	7	20.30	0-2	2
	825.5	20415	3	16-QAM	15	0	20.38	0-2	2
	Mid	836.5	20525	3	QPSK	1	0	22.52	0
836.5		20525	3	QPSK	1	7	22.28	0	0
836.5		20525	3	QPSK	1	14	22.55	0	0
836.5		20525	3	QPSK	8	0	21.30	0-1	1
836.5		20525	3	QPSK	8	4	21.24	0-1	1
836.5		20525	3	QPSK	8	7	21.43	0-1	1
836.5		20525	3	QPSK	15	0	21.34	0-1	1
836.5		20525	3	16-QAM	1	0	21.61	0-1	1
836.5		20525	3	16-QAM	1	7	21.63	0-1	1
836.5		20525	3	16-QAM	1	14	21.25	0-1	1
836.5		20525	3	16-QAM	8	0	20.41	0-2	2
836.5		20525	3	16-QAM	8	4	20.15	0-2	2
836.5		20525	3	16-QAM	8	7	20.50	0-2	2
836.5		20525	3	16-QAM	15	0	20.48	0-2	2
High		847.5	20635	3	QPSK	1	0	22.42	0
	847.5	20635	3	QPSK	1	7	22.28	0	0
	847.5	20635	3	QPSK	1	14	22.25	0	0
	847.5	20635	3	QPSK	8	0	21.40	0-1	1
	847.5	20635	3	QPSK	8	4	21.34	0-1	1
	847.5	20635	3	QPSK	8	7	21.23	0-1	1
	847.5	20635	3	QPSK	15	0	21.24	0-1	1
	847.5	20635	3	16-QAM	1	0	21.71	0-1	1
	847.5	20635	3	16-QAM	1	7	21.63	0-1	1
	847.5	20635	3	16-QAM	1	14	21.55	0-1	1
	847.5	20635	3	16-QAM	8	0	20.71	0-2	2
	847.5	20635	3	16-QAM	8	4	20.25	0-2	2
	847.5	20635	3	16-QAM	8	7	20.40	0-2	2
	847.5	20635	3	16-QAM	15	0	20.38	0-2	2

FCC ID: A3LSMV101M		<b>SAR EVALUATION REPORT</b>		Reviewed by: Quality Manager
Document S/N: OY1402240465.A3L	Test Dates: 02/24/14 - 03/05/14	DUT Type: Portable Wireless Router		Page 19 of 45

**Table 8-6  
LTE Band 5 (Cell) Conducted Powers - 1.4 MHz Bandwidth**

	Frequency [MHz]	Channel	Bandwidth [MHz]	Modulation	RB Size	RB Offset	Conducted Power [dBm]	MPR Allowed per 3GPP [dB]	MPR [dB]
Low	824.7	20407	1.4	QPSK	1	0	22.42	0	0
	824.7	20407	1.4	QPSK	1	2	22.38	0	0
	824.7	20407	1.4	QPSK	1	5	22.25	0	0
	824.7	20407	1.4	QPSK	3	0	22.20	0	0
	824.7	20407	1.4	QPSK	3	2	22.04	0	0
	824.7	20407	1.4	QPSK	3	3	22.23	0	0
	824.7	20407	1.4	QPSK	6	0	21.34	0-1	1
	824.7	20407	1.4	16-QAM	1	0	21.71	0-1	1
	824.7	20407	1.4	16-QAM	1	2	21.83	0-1	1
	824.7	20407	1.4	16-QAM	1	5	21.75	0-1	1
	824.7	20407	1.4	16-QAM	3	0	21.71	0-1	1
	824.7	20407	1.4	16-QAM	3	2	21.45	0-1	1
	824.7	20407	1.4	16-QAM	3	3	21.40	0-1	1
	824.7	20407	1.4	16-QAM	6	0	20.28	0-2	2
Mid	836.5	20525	1.4	QPSK	1	0	22.62	0	0
	836.5	20525	1.4	QPSK	1	2	22.18	0	0
	836.5	20525	1.4	QPSK	1	5	22.65	0	0
	836.5	20525	1.4	QPSK	3	0	22.30	0	0
	836.5	20525	1.4	QPSK	3	2	22.34	0	0
	836.5	20525	1.4	QPSK	3	3	22.43	0	0
	836.5	20525	1.4	QPSK	6	0	21.44	0-1	1
	836.5	20525	1.4	16-QAM	1	0	21.71	0-1	1
	836.5	20525	1.4	16-QAM	1	2	21.53	0-1	1
	836.5	20525	1.4	16-QAM	1	5	21.25	0-1	1
	836.5	20525	1.4	16-QAM	3	0	21.51	0-1	1
	836.5	20525	1.4	16-QAM	3	2	21.15	0-1	1
	836.5	20525	1.4	16-QAM	3	3	21.50	0-1	1
	836.5	20525	1.4	16-QAM	6	0	20.58	0-2	2
High	848.3	20643	1.4	QPSK	1	0	22.42	0	0
	848.3	20643	1.4	QPSK	1	2	22.28	0	0
	848.3	20643	1.4	QPSK	1	5	22.15	0	0
	848.3	20643	1.4	QPSK	3	0	22.40	0	0
	848.3	20643	1.4	QPSK	3	2	22.34	0	0
	848.3	20643	1.4	QPSK	3	3	22.13	0	0
	848.3	20643	1.4	QPSK	6	0	21.24	0-1	1
	848.3	20643	1.4	16-QAM	1	0	21.81	0-1	1
	848.3	20643	1.4	16-QAM	1	2	21.73	0-1	1
	848.3	20643	1.4	16-QAM	1	5	21.55	0-1	1
	848.3	20643	1.4	16-QAM	3	0	21.81	0-1	1
	848.3	20643	1.4	16-QAM	3	2	21.25	0-1	1
	848.3	20643	1.4	16-QAM	3	3	21.30	0-1	1
	848.3	20643	1.4	16-QAM	6	0	20.28	0-2	2

FCC ID: A3LSMV101M		<b>SAR EVALUATION REPORT</b>		Reviewed by: Quality Manager
Document S/N: OY1402240465.A3L	Test Dates: 02/24/14 - 03/05/14	DUT Type: Portable Wireless Router		Page 20 of 45

### 8.3.3 LTE Band 4 (AWS)



**Table 8-7**  
**LTE Band 4 (AWS) Conducted Powers - 20 MHz Bandwidth**

Frequency [MHz]	Channel	Bandwidth [MHz]	Modulation	RB Size	RB Offset	Conducted Power [dBm]	MPR Allowed per 3GPP [dB]	MPR [dB]
1732.5	20175	20	QPSK	1	0	22.42	0	0
1732.5	20175	20	QPSK	1	50	21.75	0	0
1732.5	20175	20	QPSK	1	99	21.95	0	0
1732.5	20175	20	QPSK	50	0	20.87	0-1	1
1732.5	20175	20	QPSK	50	25	20.60	0-1	1
1732.5	20175	20	QPSK	50	50	20.64	0-1	1
1732.5	20175	20	QPSK	100	0	20.55	0-1	1
1732.5	20175	20	16QAM	1	0	20.62	0-1	1
1732.5	20175	20	16QAM	1	50	20.88	0-1	1
1732.5	20175	20	16QAM	1	99	21.23	0-1	1
1732.5	20175	20	16QAM	50	0	19.64	0-2	2
1732.5	20175	20	16QAM	50	25	19.64	0-2	2
1732.5	20175	20	16QAM	50	50	19.60	0-2	2
1732.5	20175	20	16QAM	100	0	19.70	0-2	2

Note: LTE Band 4 at 20 MHz bandwidth does not support three non-overlapping channels. Per KDB Publication 941225 D05v02r02, when a device supports overlapping channel assignment in a channel bandwidth configuration, the middle channel of the group of overlapping channels should be selected for testing.



**Table 8-8**  
**LTE Band 4 (AWS) Conducted Powers - 15 MHz Bandwidth**

Frequency [MHz]	Channel	Bandwidth [MHz]	Modulation	RB Size	RB Offset	Conducted Power [dBm]	MPR Allowed per 3GPP [dB]	MPR [dB]
1717.5	20025	15	QPSK	1	0	21.54	0	0
1717.5	20025	15	QPSK	1	36	22.40	0	0
1717.5	20025	15	QPSK	1	74	22.24	0	0
1717.5	20025	15	QPSK	36	0	20.52	0-1	1
1717.5	20025	15	QPSK	36	18	20.56	0-1	1
1717.5	20025	15	QPSK	36	37	20.63	0-1	1
1717.5	20025	15	QPSK	75	0	20.59	0-1	1
1717.5	20025	15	16QAM	1	0	20.88	0-1	1
1717.5	20025	15	16QAM	1	36	21.04	0-1	1
1717.5	20025	15	16QAM	1	74	21.46	0-1	1
1717.5	20025	15	16QAM	36	0	19.54	0-2	2
1717.5	20025	15	16QAM	36	18	19.62	0-2	2
1717.5	20025	15	16QAM	36	37	19.50	0-2	2
1717.5	20025	15	16QAM	75	0	19.68	0-2	2
1732.5	20175	15	QPSK	1	0	22.42	0	0
1732.5	20175	15	QPSK	1	36	21.85	0	0
1732.5	20175	15	QPSK	1	74	22.15	0	0
1732.5	20175	15	QPSK	36	0	20.67	0-1	1
1732.5	20175	15	QPSK	36	18	20.50	0-1	1
1732.5	20175	15	QPSK	36	37	20.54	0-1	1
1732.5	20175	15	QPSK	75	0	20.55	0-1	1
1732.5	20175	15	16QAM	1	0	20.82	0-1	1
1732.5	20175	15	16QAM	1	36	20.88	0-1	1
1732.5	20175	15	16QAM	1	74	21.33	0-1	1
1732.5	20175	15	16QAM	36	0	19.64	0-2	2
1732.5	20175	15	16QAM	36	18	19.54	0-2	2
1732.5	20175	15	16QAM	36	37	19.70	0-2	2
1732.5	20175	15	16QAM	75	0	19.60	0-2	2
1747.5	20325	15	QPSK	1	0	22.01	0	0
1747.5	20325	15	QPSK	1	36	21.60	0	0
1747.5	20325	15	QPSK	1	74	22.12	0	0
1747.5	20325	15	QPSK	36	0	20.80	0-1	1
1747.5	20325	15	QPSK	36	18	20.72	0-1	1
1747.5	20325	15	QPSK	36	37	20.52	0-1	1
1747.5	20325	15	QPSK	75	0	20.59	0-1	1
1747.5	20325	15	16QAM	1	0	20.99	0-1	1
1747.5	20325	15	16QAM	1	36	20.56	0-1	1
1747.5	20325	15	16QAM	1	74	20.56	0-1	1
1747.5	20325	15	16QAM	36	0	19.70	0-2	2
1747.5	20325	15	16QAM	36	18	19.57	0-2	2
1747.5	20325	15	16QAM	36	37	19.50	0-2	2
1747.5	20325	15	16QAM	75	0	19.72	0-2	2

FCC ID: A3LSMV101M	 PCTEST ENGINEERING LABORATORY, INC.	SAR EVALUATION REPORT	 SAMSUNG	Reviewed by: Quality Manager
Document S/N: OY1402240465.A3L	Test Dates: 02/24/14 - 03/05/14	DUT Type: Portable Wireless Router	Page 21 of 45	



**Table 8-9  
LTE Band 4 (AWS) Conducted Powers - 10 MHz Bandwidth**

	Frequency [MHz]	Channel	Bandwidth [MHz]	Modulation	RB Size	RB Offset	Conducted Power [dBm]	MPR Allowed per 3GPP [dB]	MPR [dB]
Low	1715	20000	10	QPSK	1	0	21.54	0	0
	1715	20000	10	QPSK	1	25	22.30	0	0
	1715	20000	10	QPSK	1	49	22.34	0	0
	1715	20000	10	QPSK	25	0	20.52	0-1	1
	1715	20000	10	QPSK	25	12	20.56	0-1	1
	1715	20000	10	QPSK	25	25	20.53	0-1	1
	1715	20000	10	QPSK	50	0	20.59	0-1	1
	1715	20000	10	16QAM	1	0	20.88	0-1	1
	1715	20000	10	16QAM	1	25	20.94	0-1	1
	1715	20000	10	16QAM	1	49	21.46	0-1	1
	1715	20000	10	16QAM	25	0	19.54	0-2	2
	1715	20000	10	16QAM	25	12	19.72	0-2	2
	1715	20000	10	16QAM	25	25	19.60	0-2	2
	1715	20000	10	16QAM	50	0	19.68	0-2	2
	Mid	1732.5	20175	10	QPSK	1	0	22.42	0
1732.5		20175	10	QPSK	1	25	21.75	0	0
1732.5		20175	10	QPSK	1	49	22.05	0	0
1732.5		20175	10	QPSK	25	0	20.77	0-1	1
1732.5		20175	10	QPSK	25	12	20.60	0-1	1
1732.5		20175	10	QPSK	25	25	20.64	0-1	1
1732.5		20175	10	QPSK	50	0	20.65	0-1	1
1732.5		20175	10	16QAM	1	0	20.72	0-1	1
1732.5		20175	10	16QAM	1	25	20.98	0-1	1
1732.5		20175	10	16QAM	1	49	21.33	0-1	1
1732.5		20175	10	16QAM	25	0	19.64	0-2	2
1732.5		20175	10	16QAM	25	12	19.64	0-2	2
1732.5		20175	10	16QAM	25	25	19.60	0-2	2
1732.5		20175	10	16QAM	50	0	19.70	0-2	2
High		1750	20350	10	QPSK	1	0	22.11	0
	1750	20350	10	QPSK	1	25	21.50	0	0
	1750	20350	10	QPSK	1	49	22.02	0	0
	1750	20350	10	QPSK	25	0	20.70	0-1	1
	1750	20350	10	QPSK	25	12	20.62	0-1	1
	1750	20350	10	QPSK	25	25	20.52	0-1	1
	1750	20350	10	QPSK	50	0	20.59	0-1	1
	1750	20350	10	16QAM	1	0	20.99	0-1	1
	1750	20350	10	16QAM	1	25	20.56	0-1	1
	1750	20350	10	16QAM	1	49	20.66	0-1	1
	1750	20350	10	16QAM	25	0	19.70	0-2	2
	1750	20350	10	16QAM	25	12	19.67	0-2	2
	1750	20350	10	16QAM	25	25	19.50	0-2	2
	1750	20350	10	16QAM	50	0	19.62	0-2	2

FCC ID: A3LSMV101M		SAR EVALUATION REPORT		Reviewed by: Quality Manager
Document S/N: OY1402240465.A3L	Test Dates: 02/24/14 - 03/05/14	DUT Type: Portable Wireless Router		Page 22 of 45



**Table 8-10**  
**LTE Band 4 (AWS) Conducted Powers - 5 MHz Bandwidth**

	Frequency [MHz]	Channel	Bandwidth [MHz]	Modulation	RB Size	RB Offset	Conducted Power [dBm]	MPR Allowed per 3GPP [dB]	MPR [dB]
Low	1712.5	19975	5	QPSK	1	0	21.54	0	0
	1712.5	19975	5	QPSK	1	12	22.30	0	0
	1712.5	19975	5	QPSK	1	24	22.34	0	0
	1712.5	19975	5	QPSK	12	0	20.52	0-1	1
	1712.5	19975	5	QPSK	12	6	20.56	0-1	1
	1712.5	19975	5	QPSK	12	13	20.63	0-1	1
	1712.5	19975	5	QPSK	25	0	20.69	0-1	1
	1712.5	19975	5	16-QAM	1	0	20.98	0-1	1
	1712.5	19975	5	16-QAM	1	12	20.94	0-1	1
	1712.5	19975	5	16-QAM	1	24	21.36	0-1	1
	1712.5	19975	5	16-QAM	12	0	19.64	0-2	2
	1712.5	19975	5	16-QAM	12	6	19.72	0-2	2
	1712.5	19975	5	16-QAM	12	13	19.70	0-2	2
	1712.5	19975	5	16-QAM	25	0	19.58	0-2	2
	Mid	1732.5	20175	5	QPSK	1	0	22.42	0
1732.5		20175	5	QPSK	1	12	21.85	0	0
1732.5		20175	5	QPSK	1	24	22.15	0	0
1732.5		20175	5	QPSK	12	0	20.87	0-1	1
1732.5		20175	5	QPSK	12	6	20.50	0-1	1
1732.5		20175	5	QPSK	12	13	20.74	0-1	1
1732.5		20175	5	QPSK	25	0	20.75	0-1	1
1732.5		20175	5	16-QAM	1	0	20.72	0-1	1
1732.5		20175	5	16-QAM	1	12	21.08	0-1	1
1732.5		20175	5	16-QAM	1	24	21.33	0-1	1
1732.5		20175	5	16-QAM	12	0	19.64	0-2	2
1732.5		20175	5	16-QAM	12	6	19.74	0-2	2
1732.5		20175	5	16-QAM	12	13	19.60	0-2	2
1732.5		20175	5	16-QAM	25	0	19.60	0-2	2
High		1752.5	20375	5	QPSK	1	0	22.21	0
	1752.5	20375	5	QPSK	1	12	21.50	0	0
	1752.5	20375	5	QPSK	1	24	21.92	0	0
	1752.5	20375	5	QPSK	12	0	20.80	0-1	1
	1752.5	20375	5	QPSK	12	6	20.62	0-1	1
	1752.5	20375	5	QPSK	12	13	20.52	0-1	1
	1752.5	20375	5	QPSK	25	0	20.59	0-1	1
	1752.5	20375	5	16-QAM	1	0	20.89	0-1	1
	1752.5	20375	5	16-QAM	1	12	20.56	0-1	1
	1752.5	20375	5	16-QAM	1	24	20.56	0-1	1
	1752.5	20375	5	16-QAM	12	0	19.80	0-2	2
	1752.5	20375	5	16-QAM	12	6	19.67	0-2	2
	1752.5	20375	5	16-QAM	12	13	19.50	0-2	2
	1752.5	20375	5	16-QAM	25	0	19.62	0-2	2

FCC ID: A3LSMV101M		SAR EVALUATION REPORT		Reviewed by: Quality Manager
Document S/N: OY1402240465.A3L	Test Dates: 02/24/14 - 03/05/14	DUT Type: Portable Wireless Router		Page 23 of 45



**Table 8-11**  
**LTE Band 4 (AWS) Conducted Powers - 3 MHz Bandwidth**

	Frequency [MHz]	Channel	Bandwidth [MHz]	Modulation	RB Size	RB Offset	Conducted Power [dBm]	MPR Allowed per 3GPP [dB]	MPR [dB]
Low	1711.5	19965	3	QPSK	1	0	21.54	0	0
	1711.5	19965	3	QPSK	1	7	22.20	0	0
	1711.5	19965	3	QPSK	1	14	22.24	0	0
	1711.5	19965	3	QPSK	8	0	20.52	0-1	1
	1711.5	19965	3	QPSK	8	4	20.56	0-1	1
	1711.5	19965	3	QPSK	8	7	20.53	0-1	1
	1711.5	19965	3	QPSK	15	0	20.69	0-1	1
	1711.5	19965	3	16-QAM	1	0	20.98	0-1	1
	1711.5	19965	3	16-QAM	1	7	20.94	0-1	1
	1711.5	19965	3	16-QAM	1	14	21.46	0-1	1
	1711.5	19965	3	16-QAM	8	0	19.64	0-2	2
	1711.5	19965	3	16-QAM	8	4	19.72	0-2	2
	1711.5	19965	3	16-QAM	8	7	19.80	0-2	2
	1711.5	19965	3	16-QAM	15	0	19.58	0-2	2
	Mid	1732.5	20175	3	QPSK	1	0	22.42	0
1732.5		20175	3	QPSK	1	7	21.95	0	0
1732.5		20175	3	QPSK	1	14	22.25	0	0
1732.5		20175	3	QPSK	8	0	20.87	0-1	1
1732.5		20175	3	QPSK	8	4	20.40	0-1	1
1732.5		20175	3	QPSK	8	7	20.84	0-1	1
1732.5		20175	3	QPSK	15	0	20.85	0-1	1
1732.5		20175	3	16-QAM	1	0	20.82	0-1	1
1732.5		20175	3	16-QAM	1	7	21.18	0-1	1
1732.5		20175	3	16-QAM	1	14	21.33	0-1	1
1732.5		20175	3	16-QAM	8	0	19.54	0-2	2
1732.5		20175	3	16-QAM	8	4	19.74	0-2	2
1732.5		20175	3	16-QAM	8	7	19.50	0-2	2
1732.5		20175	3	16-QAM	15	0	19.60	0-2	2
High		1753.5	20385	3	QPSK	1	0	22.11	0
	1753.5	20385	3	QPSK	1	7	21.30	0	0
	1753.5	20385	3	QPSK	1	14	22.02	0	0
	1753.5	20385	3	QPSK	8	0	20.70	0-1	1
	1753.5	20385	3	QPSK	8	4	20.72	0-1	1
	1753.5	20385	3	QPSK	8	7	20.52	0-1	1
	1753.5	20385	3	QPSK	15	0	20.59	0-1	1
	1753.5	20385	3	16-QAM	1	0	20.89	0-1	1
	1753.5	20385	3	16-QAM	1	7	20.56	0-1	1
	1753.5	20385	3	16-QAM	1	14	20.56	0-1	1
	1753.5	20385	3	16-QAM	8	0	19.80	0-2	2
	1753.5	20385	3	16-QAM	8	4	19.77	0-2	2
	1753.5	20385	3	16-QAM	8	7	19.50	0-2	2
	1753.5	20385	3	16-QAM	15	0	19.52	0-2	2

FCC ID: A3LSMV101M		<b>SAR EVALUATION REPORT</b>		Reviewed by: Quality Manager
Document S/N: OY1402240465.A3L	Test Dates: 02/24/14 - 03/05/14	DUT Type: Portable Wireless Router		Page 24 of 45

**Table 8-12**  
**LTE Band 4 (AWS) Conducted Powers - 1.4 MHz Bandwidth**



	Frequency [MHz]	Channel	Bandwidth [MHz]	Modulation	RB Size	RB Offset	Conducted Power [dBm]	MPR Allowed per 3GPP [dB]	MPR [dB]
Low	1710.7	19957	1.4	QPSK	1	0	21.54	0	0
	1710.7	19957	1.4	QPSK	1	2	22.20	0	0
	1710.7	19957	1.4	QPSK	1	5	22.14	0	0
	1710.7	19957	1.4	QPSK	3	0	20.52	0	0
	1710.7	19957	1.4	QPSK	3	2	20.56	0	0
	1710.7	19957	1.4	QPSK	3	3	20.53	0	0
	1710.7	19957	1.4	QPSK	6	0	20.69	0-1	1
	1710.7	19957	1.4	16-QAM	1	0	21.08	0-1	1
	1710.7	19957	1.4	16-QAM	1	2	20.94	0-1	1
	1710.7	19957	1.4	16-QAM	1	5	21.46	0-1	1
	1710.7	19957	1.4	16-QAM	3	0	19.74	0-1	1
	1710.7	19957	1.4	16-QAM	3	2	19.72	0-1	1
	1710.7	19957	1.4	16-QAM	3	3	19.70	0-1	1
	1710.7	19957	1.4	16-QAM	6	0	19.58	0-2	2
Mid	1732.5	20175	1.4	QPSK	1	0	22.42	0	0
	1732.5	20175	1.4	QPSK	1	2	22.05	0	0
	1732.5	20175	1.4	QPSK	1	5	22.35	0	0
	1732.5	20175	1.4	QPSK	3	0	20.87	0	0
	1732.5	20175	1.4	QPSK	3	2	20.50	0	0
	1732.5	20175	1.4	QPSK	3	3	20.84	0	0
	1732.5	20175	1.4	QPSK	6	0	20.85	0-1	1
	1732.5	20175	1.4	16-QAM	1	0	20.92	0-1	1
	1732.5	20175	1.4	16-QAM	1	2	21.28	0-1	1
	1732.5	20175	1.4	16-QAM	1	5	21.23	0-1	1
	1732.5	20175	1.4	16-QAM	3	0	19.64	0-1	1
	1732.5	20175	1.4	16-QAM	3	2	19.74	0-1	1
	1732.5	20175	1.4	16-QAM	3	3	19.60	0-1	1
	1732.5	20175	1.4	16-QAM	6	0	19.60	0-2	2
High	1754.3	20393	1.4	QPSK	1	0	22.11	0	0
	1754.3	20393	1.4	QPSK	1	2	21.20	0	0
	1754.3	20393	1.4	QPSK	1	5	22.02	0	0
	1754.3	20393	1.4	QPSK	3	0	20.60	0	0
	1754.3	20393	1.4	QPSK	3	2	20.62	0	0
	1754.3	20393	1.4	QPSK	3	3	20.52	0	0
	1754.3	20393	1.4	QPSK	6	0	20.49	0-1	1
	1754.3	20393	1.4	16-QAM	1	0	20.99	0-1	1
	1754.3	20393	1.4	16-QAM	1	2	20.36	0-1	1
	1754.3	20393	1.4	16-QAM	1	5	20.36	0-1	1
	1754.3	20393	1.4	16-QAM	3	0	19.90	0-1	1
	1754.3	20393	1.4	16-QAM	3	2	19.87	0-1	1
	1754.3	20393	1.4	16-QAM	3	3	19.50	0-1	1
	1754.3	20393	1.4	16-QAM	6	0	19.42	0-2	2

FCC ID: A3LSMV101M		SAR EVALUATION REPORT		Reviewed by: Quality Manager
Document S/N: OY1402240465.A3L	Test Dates: 02/24/14 - 03/05/14	DUT Type: Portable Wireless Router		Page 25 of 45

### 8.3.4 LTE Band 2 (PCS)



**Table 8-13  
LTE Band 2 (PCS) Conducted Powers - 20 MHz Bandwidth**

	Frequency [MHz]	Channel	Bandwidth [MHz]	Modulation	RB Size	RB Offset	Conducted Power [dBm]	MPR Allowed per 3GPP [dB]	MPR [dB]
Low	1860	18700	20	QPSK	1	0	21.68	0	0
	1860	18700	20	QPSK	1	50	21.57	0	0
	1860	18700	20	QPSK	1	99	22.43	0	0
	1860	18700	20	QPSK	50	0	20.55	0-1	1
	1860	18700	20	QPSK	50	25	20.51	0-1	1
	1860	18700	20	QPSK	50	50	20.52	0-1	1
	1860	18700	20	QPSK	100	0	20.40	0-1	1
	1860	18700	20	16QAM	1	0	20.01	0-1	1
	1860	18700	20	16QAM	1	50	20.05	0-1	1
	1860	18700	20	16QAM	1	99	20.51	0-1	1
	1860	18700	20	16QAM	50	0	18.92	0-2	2
	1860	18700	20	16QAM	50	25	18.90	0-2	2
	1860	18700	20	16QAM	50	50	19.10	0-2	2
	1860	18700	20	16QAM	100	0	19.21	0-2	2
Mid	1880.0	18900	20	QPSK	1	0	22.09	0	0
	1880.0	18900	20	QPSK	1	50	22.43	0	0
	1880.0	18900	20	QPSK	1	99	22.33	0	0
	1880.0	18900	20	QPSK	50	0	21.05	0-1	1
	1880.0	18900	20	QPSK	50	25	21.09	0-1	1
	1880.0	18900	20	QPSK	50	50	20.86	0-1	1
	1880.0	18900	20	QPSK	100	0	20.89	0-1	1
	1880.0	18900	20	16QAM	1	0	20.77	0-1	1
	1880.0	18900	20	16QAM	1	50	21.05	0-1	1
	1880.0	18900	20	16QAM	1	99	21.06	0-1	1
	1880.0	18900	20	16QAM	50	0	19.59	0-2	2
	1880.0	18900	20	16QAM	50	25	19.68	0-2	2
	1880.0	18900	20	16QAM	50	50	19.63	0-2	2
	1880.0	18900	20	16QAM	100	0	19.58	0-2	2
High	1900	19100	20	QPSK	1	0	<b>22.44</b>	0	0
	1900	19100	20	QPSK	1	50	22.29	0	0
	1900	19100	20	QPSK	1	99	21.53	0	0
	1900	19100	20	QPSK	50	0	<b>21.40</b>	0-1	1
	1900	19100	20	QPSK	50	25	21.37	0-1	1
	1900	19100	20	QPSK	50	50	20.73	0-1	1
	1900	19100	20	QPSK	100	0	20.64	0-1	1
	1900	19100	20	16QAM	1	0	20.68	0-1	1
	1900	19100	20	16QAM	1	50	20.52	0-1	1
	1900	19100	20	16QAM	1	99	20.16	0-1	1
	1900	19100	20	16QAM	50	0	19.94	0-2	2
	1900	19100	20	16QAM	50	25	19.63	0-2	2
	1900	19100	20	16QAM	50	50	19.64	0-2	2
	1900	19100	20	16QAM	100	0	19.46	0-2	2

FCC ID: A3LSMV101M		<b>SAR EVALUATION REPORT</b>		<b>Reviewed by:</b> Quality Manager
<b>Document S/N:</b> OY1402240465.A3L	<b>Test Dates:</b> 02/24/14 - 03/05/14	<b>DUT Type:</b> Portable Wireless Router		Page 26 of 45



**Table 8-14**  
**LTE Band 2 (PCS) Conducted Powers - 15 MHz Bandwidth**

	Frequency [MHz]	Channel	Bandwidth [MHz]	Modulation	RB Size	RB Offset	Conducted Power [dBm]	MPR Allowed per 3GPP [dB]	MPR [dB]
Low	1857.5	18675	15	QPSK	1	0	21.68	0	0
	1857.5	18675	15	QPSK	1	36	21.57	0	0
	1857.5	18675	15	QPSK	1	74	22.43	0	0
	1857.5	18675	15	QPSK	36	0	20.55	0-1	1
	1857.5	18675	15	QPSK	36	18	20.41	0-1	1
	1857.5	18675	15	QPSK	36	37	20.62	0-1	1
	1857.5	18675	15	QPSK	75	0	20.50	0-1	1
	1857.5	18675	15	16QAM	1	0	20.01	0-1	1
	1857.5	18675	15	16QAM	1	36	20.15	0-1	1
	1857.5	18675	15	16QAM	1	74	20.41	0-1	1
	1857.5	18675	15	16QAM	36	0	19.02	0-2	2
	1857.5	18675	15	16QAM	36	18	19.00	0-2	2
	1857.5	18675	15	16QAM	36	37	19.10	0-2	2
	1857.5	18675	15	16QAM	75	0	19.11	0-2	2
	Mid	1880.0	18900	15	QPSK	1	0	22.19	0
1880.0		18900	15	QPSK	1	36	22.34	0	0
1880.0		18900	15	QPSK	1	74	22.43	0	0
1880.0		18900	15	QPSK	36	0	21.05	0-1	1
1880.0		18900	15	QPSK	36	18	21.19	0-1	1
1880.0		18900	15	QPSK	36	37	20.76	0-1	1
1880.0		18900	15	QPSK	75	0	20.79	0-1	1
1880.0		18900	15	16QAM	1	0	20.67	0-1	1
1880.0		18900	15	16QAM	1	36	21.05	0-1	1
1880.0		18900	15	16QAM	1	74	20.96	0-1	1
1880.0		18900	15	16QAM	36	0	19.69	0-2	2
1880.0		18900	15	16QAM	36	18	19.68	0-2	2
1880.0		18900	15	16QAM	36	37	19.53	0-2	2
1880.0		18900	15	16QAM	75	0	19.68	0-2	2
High		1902.5	19125	15	QPSK	1	0	22.39	0
	1902.5	19125	15	QPSK	1	36	22.42	0	0
	1902.5	19125	15	QPSK	1	74	21.63	0	0
	1902.5	19125	15	QPSK	36	0	21.40	0-1	1
	1902.5	19125	15	QPSK	36	18	21.37	0-1	1
	1902.5	19125	15	QPSK	36	37	20.73	0-1	1
	1902.5	19125	15	QPSK	75	0	20.64	0-1	1
	1902.5	19125	15	16QAM	1	0	20.68	0-1	1
	1902.5	19125	15	16QAM	1	36	20.52	0-1	1
	1902.5	19125	15	16QAM	1	74	20.06	0-1	1
	1902.5	19125	15	16QAM	36	0	19.84	0-2	2
	1902.5	19125	15	16QAM	36	18	19.63	0-2	2
	1902.5	19125	15	16QAM	36	37	19.64	0-2	2
	1902.5	19125	15	16QAM	75	0	19.56	0-2	2

FCC ID: A3LSMV101M		<b>SAR EVALUATION REPORT</b>		Reviewed by: Quality Manager
Document S/N: OY1402240465.A3L	Test Dates: 02/24/14 - 03/05/14	DUT Type: Portable Wireless Router		Page 27 of 45



**Table 8-15**  
**LTE Band 2 (PCS) Conducted Powers - 10 MHz Bandwidth**

	Frequency [MHz]	Channel	Bandwidth [MHz]	Modulation	RB Size	RB Offset	Conducted Power [dBm]	MPR Allowed per 3GPP [dB]	MPR [dB]
Low	1855	18650	10	QPSK	1	0	21.68	0	0
	1855	18650	10	QPSK	1	25	21.57	0	0
	1855	18650	10	QPSK	1	49	22.33	0	0
	1855	18650	10	QPSK	25	0	20.55	0-1	1
	1855	18650	10	QPSK	25	12	20.51	0-1	1
	1855	18650	10	QPSK	25	25	20.52	0-1	1
	1855	18650	10	QPSK	50	0	20.50	0-1	1
	1855	18650	10	16QAM	1	0	20.01	0-1	1
	1855	18650	10	16QAM	1	25	20.15	0-1	1
	1855	18650	10	16QAM	1	49	20.31	0-1	1
	1855	18650	10	16QAM	25	0	19.02	0-2	2
	1855	18650	10	16QAM	25	12	19.00	0-2	2
	1855	18650	10	16QAM	25	25	19.10	0-2	2
	1855	18650	10	16QAM	50	0	19.01	0-2	2
	Mid	1880.0	18900	10	QPSK	1	0	22.09	0
1880.0		18900	10	QPSK	1	25	22.44	0	0
1880.0		18900	10	QPSK	1	49	22.43	0	0
1880.0		18900	10	QPSK	25	0	21.05	0-1	1
1880.0		18900	10	QPSK	25	12	21.09	0-1	1
1880.0		18900	10	QPSK	25	25	20.86	0-1	1
1880.0		18900	10	QPSK	50	0	20.79	0-1	1
1880.0		18900	10	16QAM	1	0	20.77	0-1	1
1880.0		18900	10	16QAM	1	25	21.15	0-1	1
1880.0		18900	10	16QAM	1	49	21.06	0-1	1
1880.0		18900	10	16QAM	25	0	19.79	0-2	2
1880.0		18900	10	16QAM	25	12	19.78	0-2	2
1880.0		18900	10	16QAM	25	25	19.63	0-2	2
1880.0		18900	10	16QAM	50	0	19.68	0-2	2
High		1905	19150	10	QPSK	1	0	22.49	0
	1905	19150	10	QPSK	1	25	22.42	0	0
	1905	19150	10	QPSK	1	49	21.63	0	0
	1905	19150	10	QPSK	25	0	21.30	0-1	1
	1905	19150	10	QPSK	25	12	21.27	0-1	1
	1905	19150	10	QPSK	25	25	20.73	0-1	1
	1905	19150	10	QPSK	50	0	20.64	0-1	1
	1905	19150	10	16QAM	1	0	20.78	0-1	1
	1905	19150	10	16QAM	1	25	20.52	0-1	1
	1905	19150	10	16QAM	1	49	20.06	0-1	1
	1905	19150	10	16QAM	25	0	19.74	0-2	2
	1905	19150	10	16QAM	25	12	19.63	0-2	2
	1905	19150	10	16QAM	25	25	19.64	0-2	2
	1905	19150	10	16QAM	50	0	19.66	0-2	2

FCC ID: A3LSMV101M		<b>SAR EVALUATION REPORT</b>		Reviewed by: Quality Manager
Document S/N: OY1402240465.A3L	Test Dates: 02/24/14 - 03/05/14	DUT Type: Portable Wireless Router		Page 28 of 45



**Table 8-16  
LTE Band 2 (PCS) Conducted Powers - 5 MHz Bandwidth**

	Frequency [MHz]	Channel	Bandwidth [MHz]	Modulation	RB Size	RB Offset	Conducted Power [dBm]	MPR Allowed per 3GPP [dB]	MPR [dB]
Low	1852.5	18625	5	QPSK	1	0	21.78	0	0
	1852.5	18625	5	QPSK	1	12	21.67	0	0
	1852.5	18625	5	QPSK	1	24	22.33	0	0
	1852.5	18625	5	QPSK	12	0	20.55	0-1	1
	1852.5	18625	5	QPSK	12	6	20.51	0-1	1
	1852.5	18625	5	QPSK	12	13	20.42	0-1	1
	1852.5	18625	5	QPSK	25	0	20.50	0-1	1
	1852.5	18625	5	16-QAM	1	0	20.01	0-1	1
	1852.5	18625	5	16-QAM	1	12	20.15	0-1	1
	1852.5	18625	5	16-QAM	1	24	20.41	0-1	1
	1852.5	18625	5	16-QAM	12	0	19.02	0-2	2
	1852.5	18625	5	16-QAM	12	6	19.10	0-2	2
	1852.5	18625	5	16-QAM	12	13	19.10	0-2	2
	1852.5	18625	5	16-QAM	25	0	19.01	0-2	2
	Mid	1880.0	18900	5	QPSK	1	0	22.09	0
1880.0		18900	5	QPSK	1	12	22.44	0	0
1880.0		18900	5	QPSK	1	24	22.43	0	0
1880.0		18900	5	QPSK	12	0	21.15	0-1	1
1880.0		18900	5	QPSK	12	6	21.09	0-1	1
1880.0		18900	5	QPSK	12	13	20.86	0-1	1
1880.0		18900	5	QPSK	25	0	20.69	0-1	1
1880.0		18900	5	16-QAM	1	0	20.67	0-1	1
1880.0		18900	5	16-QAM	1	12	21.25	0-1	1
1880.0		18900	5	16-QAM	1	24	21.16	0-1	1
1880.0		18900	5	16-QAM	12	0	19.89	0-2	2
1880.0		18900	5	16-QAM	12	6	19.68	0-2	2
1880.0		18900	5	16-QAM	12	13	19.73	0-2	2
1880.0		18900	5	16-QAM	25	0	19.58	0-2	2
High		1907.5	19175	5	QPSK	1	0	22.46	0
	1907.5	19175	5	QPSK	1	12	22.32	0	0
	1907.5	19175	5	QPSK	1	24	21.73	0	0
	1907.5	19175	5	QPSK	12	0	21.30	0-1	1
	1907.5	19175	5	QPSK	12	6	21.27	0-1	1
	1907.5	19175	5	QPSK	12	13	20.73	0-1	1
	1907.5	19175	5	QPSK	25	0	20.64	0-1	1
	1907.5	19175	5	16-QAM	1	0	20.78	0-1	1
	1907.5	19175	5	16-QAM	1	12	20.52	0-1	1
	1907.5	19175	5	16-QAM	1	24	20.16	0-1	1
	1907.5	19175	5	16-QAM	12	0	19.84	0-2	2
	1907.5	19175	5	16-QAM	12	6	19.63	0-2	2
	1907.5	19175	5	16-QAM	12	13	19.74	0-2	2
	1907.5	19175	5	16-QAM	25	0	19.56	0-2	2

FCC ID: A3LSMV101M		<b>SAR EVALUATION REPORT</b>		Reviewed by: Quality Manager
Document S/N: OY1402240465.A3L	Test Dates: 02/24/14 - 03/05/14	DUT Type: Portable Wireless Router		Page 29 of 45



**Table 8-17**  
**LTE Band 2 (PCS) Conducted Powers - 3 MHz Bandwidth**

	Frequency [MHz]	Channel	Bandwidth [MHz]	Modulation	RB Size	RB Offset	Conducted Power [dBm]	MPR Allowed per 3GPP [dB]	MPR [dB]
Low	1851.5	18615	3	QPSK	1	0	21.68	0	0
	1851.5	18615	3	QPSK	1	7	21.77	0	0
	1851.5	18615	3	QPSK	1	14	22.43	0	0
	1851.5	18615	3	QPSK	8	0	20.45	0-1	1
	1851.5	18615	3	QPSK	8	4	20.61	0-1	1
	1851.5	18615	3	QPSK	8	7	20.52	0-1	1
	1851.5	18615	3	QPSK	15	0	20.60	0-1	1
	1851.5	18615	3	16-QAM	1	0	20.11	0-1	1
	1851.5	18615	3	16-QAM	1	7	20.15	0-1	1
	1851.5	18615	3	16-QAM	1	14	20.51	0-1	1
	1851.5	18615	3	16-QAM	8	0	19.12	0-2	2
	1851.5	18615	3	16-QAM	8	4	19.20	0-2	2
	1851.5	18615	3	16-QAM	8	7	19.10	0-2	2
	1851.5	18615	3	16-QAM	15	0	18.91	0-2	2
	Mid	1880.0	18900	3	QPSK	1	0	21.99	0
1880.0		18900	3	QPSK	1	7	22.45	0	0
1880.0		18900	3	QPSK	1	14	22.36	0	0
1880.0		18900	3	QPSK	8	0	21.15	0-1	1
1880.0		18900	3	QPSK	8	4	20.99	0-1	1
1880.0		18900	3	QPSK	8	7	20.86	0-1	1
1880.0		18900	3	QPSK	15	0	20.69	0-1	1
1880.0		18900	3	16-QAM	1	0	20.77	0-1	1
1880.0		18900	3	16-QAM	1	7	21.25	0-1	1
1880.0		18900	3	16-QAM	1	14	21.06	0-1	1
1880.0		18900	3	16-QAM	8	0	19.89	0-2	2
1880.0		18900	3	16-QAM	8	4	19.68	0-2	2
1880.0		18900	3	16-QAM	8	7	19.63	0-2	2
1880.0		18900	3	16-QAM	15	0	19.48	0-2	2
High		1908.5	19185	3	QPSK	1	0	22.49	0
	1908.5	19185	3	QPSK	1	7	22.32	0	0
	1908.5	19185	3	QPSK	1	14	21.83	0	0
	1908.5	19185	3	QPSK	8	0	21.20	0-1	1
	1908.5	19185	3	QPSK	8	4	21.27	0-1	1
	1908.5	19185	3	QPSK	8	7	20.63	0-1	1
	1908.5	19185	3	QPSK	15	0	20.64	0-1	1
	1908.5	19185	3	16-QAM	1	0	20.78	0-1	1
	1908.5	19185	3	16-QAM	1	7	20.62	0-1	1
	1908.5	19185	3	16-QAM	1	14	20.26	0-1	1
	1908.5	19185	3	16-QAM	8	0	19.74	0-2	2
	1908.5	19185	3	16-QAM	8	4	19.63	0-2	2
	1908.5	19185	3	16-QAM	8	7	19.84	0-2	2
	1908.5	19185	3	16-QAM	15	0	19.56	0-2	2

FCC ID: A3LSMV101M		<b>SAR EVALUATION REPORT</b>		<b>Reviewed by:</b> Quality Manager
<b>Document S/N:</b> OY1402240465.A3L	<b>Test Dates:</b> 02/24/14 - 03/05/14	<b>DUT Type:</b> Portable Wireless Router		Page 30 of 45

**Table 8-18  
LTE Band 2 (PCS) Conducted Powers - 1.4 MHz Bandwidth**

	Frequency [MHz]	Channel	Bandwidth [MHz]	Modulation	RB Size	RB Offset	Conducted Power [dBm]	MPR Allowed per 3GPP [dB]	MPR [dB]
Low	1850.7	18607	1.4	QPSK	1	0	21.68	0	0
	1850.7	18607	1.4	QPSK	1	2	21.87	0	0
	1850.7	18607	1.4	QPSK	1	5	22.43	0	0
	1850.7	18607	1.4	QPSK	3	0	20.55	0	0
	1850.7	18607	1.4	QPSK	3	2	20.71	0	0
	1850.7	18607	1.4	QPSK	3	3	20.52	0	0
	1850.7	18607	1.4	QPSK	6	0	20.50	0-1	1
	1850.7	18607	1.4	16-QAM	1	0	20.11	0-1	1
	1850.7	18607	1.4	16-QAM	1	2	20.25	0-1	1
	1850.7	18607	1.4	16-QAM	1	5	20.61	0-1	1
	1850.7	18607	1.4	16-QAM	3	0	20.12	0-1	1
	1850.7	18607	1.4	16-QAM	3	2	20.30	0-1	1
	1850.7	18607	1.4	16-QAM	3	3	20.10	0-1	1
	1850.7	18607	1.4	16-QAM	6	0	19.01	0-2	2
	Mid	1880.0	18900	1.4	QPSK	1	0	22.09	0
1880.0		18900	1.4	QPSK	1	2	22.45	0	0
1880.0		18900	1.4	QPSK	1	5	22.43	0	0
1880.0		18900	1.4	QPSK	3	0	21.25	0	0
1880.0		18900	1.4	QPSK	3	2	20.99	0	0
1880.0		18900	1.4	QPSK	3	3	20.86	0	0
1880.0		18900	1.4	QPSK	6	0	20.59	0-1	1
1880.0		18900	1.4	16-QAM	1	0	20.87	0-1	1
1880.0		18900	1.4	16-QAM	1	2	21.25	0-1	1
1880.0		18900	1.4	16-QAM	1	5	20.96	0-1	1
1880.0		18900	1.4	16-QAM	3	0	19.89	0-1	1
1880.0		18900	1.4	16-QAM	3	2	19.68	0-1	1
1880.0		18900	1.4	16-QAM	3	3	19.53	0-1	1
1880.0		18900	1.4	16-QAM	6	0	19.58	0-2	2
High		1909.3	19193	1.4	QPSK	1	0	22.39	0
	1909.3	19193	1.4	QPSK	1	2	22.42	0	0
	1909.3	19193	1.4	QPSK	1	5	21.73	0	0
	1909.3	19193	1.4	QPSK	3	0	21.20	0	0
	1909.3	19193	1.4	QPSK	3	2	21.17	0	0
	1909.3	19193	1.4	QPSK	3	3	20.63	0	0
	1909.3	19193	1.4	QPSK	6	0	20.54	0-1	1
	1909.3	19193	1.4	16-QAM	1	0	20.88	0-1	1
	1909.3	19193	1.4	16-QAM	1	2	20.62	0-1	1
	1909.3	19193	1.4	16-QAM	1	5	20.16	0-1	1
	1909.3	19193	1.4	16-QAM	3	0	19.84	0-1	1
	1909.3	19193	1.4	16-QAM	3	2	19.73	0-1	1
	1909.3	19193	1.4	16-QAM	3	3	19.74	0-1	1
	1909.3	19193	1.4	16-QAM	6	0	19.66	0-2	2

FCC ID: A3LSMV101M		<b>SAR EVALUATION REPORT</b>		Reviewed by: Quality Manager
Document S/N: OY1402240465.A3L	Test Dates: 02/24/14 - 03/05/14	DUT Type: Portable Wireless Router		Page 31 of 45

## 8.4 WLAN Conducted Powers

**Table 8-19**  
**IEEE 802.11b Average RF Power**

Mode	Freq [MHz]	Channel	802.11b (2.4 GHz) Conducted Power [dBm]			
			Data Rate [Mbps]			
			1	2	5.5	11
802.11b	2412	1*	<b>17.09</b>	16.94	16.95	16.89
802.11b	2437	6*	16.87	16.74	16.94	16.94
802.11b	2462	11*	16.78	16.84	16.74	16.71

**Table 8-20**  
**IEEE 802.11g Average RF Power**

Mode	Freq [MHz]	Channel	802.11g (2.4 GHz) Conducted Power [dBm]							
			Data Rate [Mbps]							
			6	9	12	18	24	36	48	54
802.11g	2412	1	14.14	14.02	13.96	14.16	14.15	14.11	14.21	14.22
802.11g	2437	6	14.12	14.19	14.07	14.05	14.18	14.11	14.18	14.22
802.11g	2462	11	14.01	14.14	14.03	13.92	14.03	14.16	14.19	14.15

**Table 8-21**  
**IEEE 802.11n Average RF Power**



Mode	Freq [MHz]	Channel	802.11n (2.4 GHz) Conducted Power [dBm]							
			Data Rate [Mbps]							
			6.5	13	20	26	39	52	58	65
802.11n	2412	1	12.25	12.01	11.71	11.89	11.98	12.12	11.74	11.78
802.11n	2437	6	11.57	11.57	11.33	11.50	11.60	11.85	11.55	11.75
802.11n	2462	11	11.46	11.63	11.56	11.78	11.90	12.35	12.11	12.15

Justification for reduced test configurations for WIFI channels per KDB Publication 248227 D01v01r02 and October 2012/April 2013 FCC/TCB Meeting Notes:

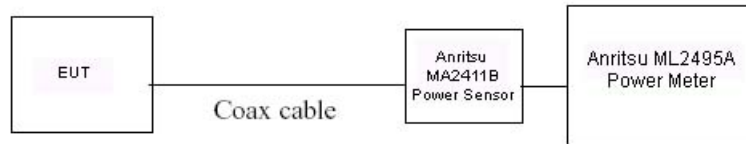
- For 2.4 GHz, highest average RF output power channel for the lowest data rate for IEEE 802.11b were selected for SAR evaluation. Other IEEE 802.11 modes (including 802.11g/n) were not investigated since the average output powers over all channels and data rates were not more than 0.25 dB higher than the tested channel in the lowest data rate of IEEE 802.11b mode.
- When the maximum extrapolated peak SAR of the zoom scan for the maximum output channel is <1.6 W/kg and the reported 1g averaged SAR is <0.8 W/kg, SAR testing on other channels is not required. Otherwise, the other default (or corresponding required) test channels were additionally tested using the lowest data rate.
- The bolded data rate and channel above were tested for SAR.



**Figure 8-3**  
**Power Measurement Setup**

FCC ID: A3LSMV101M		SAR EVALUATION REPORT		Reviewed by: Quality Manager
Document S/N: OY1402240465.A3L	Test Dates: 02/24/14 - 03/05/14	DUT Type: Portable Wireless Router		Page 32 of 45



## 9 SYSTEM VERIFICATION

### 9.1 Tissue Verification

**Table 9-1  
Measured Tissue Properties**

Calibrated for Tests Performed on:	Tissue Type	Tissue Temp During Calibration (C°)	Measured Frequency (MHz)	Measured Conductivity, $\sigma$ (S/m)	Measured Dielectric Constant, $\epsilon$	TARGET Conductivity, $\sigma$ (S/m)	TARGET Dielectric Constant, $\epsilon$	% dev $\sigma$	% dev $\epsilon$
02/28/2014	740B	21.7	710	0.945	53.690	0.960	55.687	-1.56%	-3.59%
			740	0.974	53.356	0.963	55.570	1.14%	-3.98%
			755	0.990	53.179	0.964	55.512	2.70%	-4.20%
02/27/2014	835B	22.9	820	0.984	53.477	0.969	55.258	1.55%	-3.22%
			835	0.999	53.320	0.970	55.200	2.99%	-3.41%
			850	1.014	53.170	0.988	55.154	2.63%	-3.60%
02/24/2014	1750B	23.0	1710	1.433	51.708	1.463	53.537	-2.05%	-3.42%
			1750	1.476	51.565	1.488	53.432	-0.81%	-3.49%
			1790	1.524	51.460	1.514	53.326	0.66%	-3.50%
02/24/2014	1900B	23.1	1850	1.482	51.713	1.520	53.300	-2.50%	-2.98%
			1880	1.515	51.631	1.520	53.300	-0.33%	-3.13%
			1910	1.551	51.525	1.520	53.300	2.04%	-3.33%
03/05/2014	2450B	22.9	2401	1.972	51.509	1.903	52.765	3.63%	-2.38%
			2450	2.044	51.296	1.950	52.700	4.82%	-2.66%
			2499	2.109	51.166	2.019	52.638	4.46%	-2.80%

The above measured tissue parameters were used in the DASY software. The DASY software was used to perform interpolation to determine the dielectric parameters at the SAR test device frequencies (per IEEE 1528 6.6.1.2). The tissue parameters listed in the SAR test plots may slightly differ from the table above due to significant digit rounding in the software.

FCC ID: A3LSMV101M		SAR EVALUATION REPORT		Reviewed by: Quality Manager
Document S/N: 0Y1402240465.A3L	Test Dates: 02/24/14 - 03/05/14	DUT Type: Portable Wireless Router		Page 33 of 45

## 9.2 Test System Verification

Prior to SAR assessment, the system is verified to  $\pm 10\%$  of the SAR measurement on the reference dipole at the time of calibration by the calibration facility. Full system validation status and result summary can be found in Appendix E.

**Table 9-2  
System Verification Results**

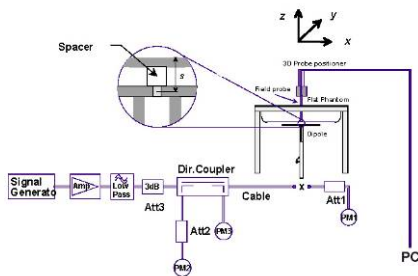

System Verification TARGET & MEASURED												
SAR System #	Tissue Frequency (MHz)	Tissue Type	Date:	Amb. Temp (°C)	Liquid Temp (°C)	Input Power (W)	Dipole SN	Probe SN	Measured SAR <sub>1g</sub> (W/kg)	1 W Target SAR <sub>1g</sub> (W/kg)	1 W Normalized SAR <sub>1g</sub> (W/kg)	Deviation <sub>1g</sub> (%)
H	750	BODY	02/28/2014	23.6	21.8	0.100	1003	3318	0.897	8.770	8.970	2.28%
G	835	BODY	02/27/2014	24.4	22.9	0.100	4d119	3209	0.941	9.540	9.410	-1.36%
G	1750	BODY	02/24/2014	24.4	23.0	0.100	1051	3209	3.570	37.800	35.700	-5.56%
G	1900	BODY	02/24/2014	24.4	23.0	0.100	5d149	3209	3.920	40.500	39.200	-3.21%
G	2450	BODY	03/05/2014	24.3	23.3	0.100	719	3258	5.120	51.700	51.200	-0.97%



**Figure 9-1  
System Verification Setup Diagram**



**Figure 9-2  
System Verification Setup Photo**

FCC ID: A3LSMV101M	 PCTEST ENGINEERING LABORATORY, INC.	SAR EVALUATION REPORT	 SAMSUNG	Reviewed by: Quality Manager
Document S/N: 0Y1402240465.A3L	Test Dates: 02/24/14 - 03/05/14	DUT Type: Portable Wireless Router	Page 34 of 45	

# 10 SAR DATA SUMMARY



## 10.1 Standalone Wireless Router SAR Data

**Table 10-1  
GPRS/UMTS Hotspot SAR Data**

MEASUREMENT RESULTS															
FREQUENCY		Mode	Service	Maximum Allowed Power [dBm]	Conducted Power [dBm]	Power Drift [dB]	Spacing	Device Serial Number	# of GPRS Slots	Duty Cycle	Side	SAR (1g)	Scaling Factor	Scaled SAR (1g)	Plot #
MHz	Ch.											(W/kg)		(W/kg)	
836.60	190	GSM 850	GPRS	29.5	28.85	-0.02	10 mm	1902-1	2	1:4.15	back	0.572	1.161	0.664	
836.60	190	GSM 850	GPRS	29.5	28.85	0.03	10 mm	1902-1	2	1:4.15	front	0.621	1.161	0.721	A1
836.60	190	GSM 850	GPRS	29.5	28.85	0.09	10 mm	1902-1	2	1:4.15	top	0.114	1.161	0.132	
836.60	190	GSM 850	GPRS	29.5	28.85	0.03	10 mm	1902-1	2	1:4.15	right	0.147	1.161	0.171	
836.60	190	GSM 850	GPRS	29.5	28.85	0.04	10 mm	1902-1	2	1:4.15	left	0.298	1.161	0.346	
836.60	4183	UMTS 850	RMC	23.0	22.42	0.03	10 mm	1902-2	N/A	1:1	back	0.261	1.143	0.298	
836.60	4183	UMTS 850	RMC	23.0	22.42	0.07	10 mm	1902-2	N/A	1:1	front	0.292	1.143	0.334	A2
836.60	4183	UMTS 850	RMC	23.0	22.42	0.00	10 mm	1902-2	N/A	1:1	top	0.082	1.143	0.094	
836.60	4183	UMTS 850	RMC	23.0	22.42	0.04	10 mm	1902-2	N/A	1:1	right	0.034	1.143	0.039	
836.60	4183	UMTS 850	RMC	23.0	22.42	0.06	10 mm	1902-2	N/A	1:1	left	0.120	1.143	0.137	
1880.00	661	GSM 1900	GPRS	26.5	26.44	-0.06	10 mm	1902-1	2	1:4.15	back	0.258	1.014	0.262	
1880.00	661	GSM 1900	GPRS	26.5	26.44	-0.03	10 mm	1902-1	2	1:4.15	front	0.319	1.014	0.323	A3
1880.00	661	GSM 1900	GPRS	26.5	26.44	-0.10	10 mm	1902-1	2	1:4.15	top	0.147	1.014	0.149	
1880.00	661	GSM 1900	GPRS	26.5	26.44	0.00	10 mm	1902-1	2	1:4.15	right	0.060	1.014	0.061	
1880.00	661	GSM 1900	GPRS	26.5	26.44	0.01	10 mm	1902-1	2	1:4.15	left	0.116	1.014	0.118	
1880.00	9400	UMTS 1900	RMC	23.0	22.05	-0.05	10 mm	1902-2	N/A	1:1	back	0.604	1.245	0.752	
1852.40	9262	UMTS 1900	RMC	23.0	21.97	0.00	10 mm	1902-2	N/A	1:1	front	0.464	1.268	0.588	
1880.00	9400	UMTS 1900	RMC	23.0	22.05	-0.01	10 mm	1902-2	N/A	1:1	front	0.652	1.245	0.812	A4
1907.60	9538	UMTS 1900	RMC	23.0	22.03	-0.01	10 mm	1902-2	N/A	1:1	front	0.565	1.250	0.706	
1880.00	9400	UMTS 1900	RMC	23.0	22.05	0.03	10 mm	1902-2	N/A	1:1	top	0.323	1.245	0.402	
1880.00	9400	UMTS 1900	RMC	23.0	22.05	0.02	10 mm	1902-2	N/A	1:1	right	0.129	1.245	0.161	
1880.00	9400	UMTS 1900	RMC	23.0	22.05	0.00	10 mm	1902-2	N/A	1:1	left	0.289	1.245	0.360	
ANSI / IEEE C95.1 1992 - SAFETY LIMIT Spatial Peak Uncontrolled Exposure/General Population							Body 1.6 W/kg (mW/g) averaged over 1 gram								

**Table 10-2  
LTE Band 17 Hotspot SAR**

MEASUREMENT RESULTS																			
FREQUENCY		Mode	Bandwidth [MHz]	Maximum Allowed Power [dBm]	Conducted Power [dBm]	Power Drift [dB]	MPR [dB]	Device Serial Number	Modulation	RB Size	RB Offset	Spacing	Side	Duty Cycle	SAR (1g)	Scaling Factor	Scaled SAR (1g)	Plot #	
MHz	Ch.														(W/kg)		(W/kg)		
710.00	23790	Mid	LTE Band 17	10	23.0	23.00	-0.15	0	1902-3	QPSK	1	49	10 mm	back	1:1	0.512	1.000	0.512	
710.00	23790	Mid	LTE Band 17	10	22.0	21.92	-0.10	1	1902-3	QPSK	25	12	10 mm	back	1:1	0.315	1.019	0.321	
710.00	23790	Mid	LTE Band 17	10	23.0	23.00	0.00	0	1902-3	QPSK	1	49	10 mm	front	1:1	0.552	1.000	0.552	A5
710.00	23790	Mid	LTE Band 17	10	22.0	21.92	-0.07	1	1902-3	QPSK	25	12	10 mm	front	1:1	0.323	1.019	0.329	
710.00	23790	Mid	LTE Band 17	10	23.0	23.00	0.03	0	1902-3	QPSK	1	49	10 mm	top	1:1	0.171	1.000	0.171	
710.00	23790	Mid	LTE Band 17	10	22.0	21.92	-0.03	1	1902-3	QPSK	25	12	10 mm	top	1:1	0.110	1.019	0.112	
710.00	23790	Mid	LTE Band 17	10	23.0	23.00	0.00	0	1902-3	QPSK	1	49	10 mm	right	1:1	0.121	1.000	0.121	
710.00	23790	Mid	LTE Band 17	10	22.0	21.92	0.03	1	1902-3	QPSK	25	12	10 mm	right	1:1	0.071	1.019	0.072	
710.00	23790	Mid	LTE Band 17	10	23.0	23.00	0.00	0	1902-3	QPSK	1	49	10 mm	left	1:1	0.137	1.000	0.137	
710.00	23790	Mid	LTE Band 17	10	22.0	21.92	0.02	1	1902-3	QPSK	25	12	10 mm	left	1:1	0.076	1.019	0.077	
ANSI / IEEE C95.1 1992 - SAFETY LIMIT Spatial Peak Uncontrolled Exposure/General Population							Body 1.6 W/kg (mW/g) averaged over 1 gram												

FCC ID: A3LSMV101M		SAR EVALUATION REPORT		Reviewed by: Quality Manager
Document S/N: OY1402240465.A3L	Test Dates: 02/24/14 - 03/05/14	DUT Type: Portable Wireless Router		Page 35 of 45

**Table 10-3  
LTE Band 5 (Cell) Hotspot SAR**

MEASUREMENT RESULTS																			
FREQUENCY		Mode	Bandwidth [MHz]	Maximum Allowed Power [dBm]	Conducted Power [dBm]	Power Drift [dB]	MPR [dB]	Device Serial Number	Modulation	RB Size	RB Offset	Spacing	Side	Duty Cycle	SAR (1g)	Scaling Factor	Scaled SAR (1g)	Plot #	
MHz	Ch.														(W/kg)		(W/kg)		
836.50	20525	Mid	LTE Band 5 (Cell)	10	23.0	22.52	0.00	0	1902-3	QPSK	1	0	10 mm	back	1:1	0.187	1.117	0.209	
836.50	20525	Mid	LTE Band 5 (Cell)	10	22.0	21.30	0.01	1	1902-3	QPSK	25	0	10 mm	back	1:1	0.155	1.175	0.182	
836.50	20525	Mid	LTE Band 5 (Cell)	10	23.0	22.52	0.00	0	1902-3	QPSK	1	0	10 mm	front	1:1	0.212	1.117	0.237	A6
836.50	20525	Mid	LTE Band 5 (Cell)	10	22.0	21.30	0.02	1	1902-3	QPSK	25	0	10 mm	front	1:1	0.176	1.175	0.207	
836.50	20525	Mid	LTE Band 5 (Cell)	10	23.0	22.52	0.13	0	1902-3	QPSK	1	0	10 mm	top	1:1	0.058	1.117	0.065	
836.50	20525	Mid	LTE Band 5 (Cell)	10	22.0	21.30	0.04	1	1902-3	QPSK	25	0	10 mm	top	1:1	0.046	1.175	0.054	
836.50	20525	Mid	LTE Band 5 (Cell)	10	23.0	22.52	0.07	0	1902-3	QPSK	1	0	10 mm	right	1:1	0.030	1.117	0.034	
836.50	20525	Mid	LTE Band 5 (Cell)	10	22.0	21.30	0.19	1	1902-3	QPSK	25	0	10 mm	right	1:1	0.023	1.175	0.027	
836.50	20525	Mid	LTE Band 5 (Cell)	10	23.0	22.52	0.03	0	1902-3	QPSK	1	0	10 mm	left	1:1	0.113	1.117	0.126	
836.50	20525	Mid	LTE Band 5 (Cell)	10	22.0	21.30	0.04	1	1902-3	QPSK	25	0	10 mm	left	1:1	0.090	1.175	0.106	
ANSI / IEEE C95.1 1992 - SAFETY LIMIT										Body									
Spatial Peak										1.6 W/kg (mW/g)									
Uncontrolled Exposure/General Population										averaged over 1 gram									

**Table 10-4  
LTE Band 4 (AWS) Hotspot SAR**

MEASUREMENT RESULTS																			
FREQUENCY		Mode	Bandwidth [MHz]	Maximum Allowed Power [dBm]	Conducted Power [dBm]	Power Drift [dB]	MPR [dB]	Device Serial Number	Modulation	RB Size	RB Offset	Spacing	Side	Duty Cycle	SAR (1g)	Scaling Factor	Scaled SAR (1g)	Plot #	
MHz	Ch.														(W/kg)		(W/kg)		
1732.50	20175	Mid	LTE Band 4 (AWS)	20	22.5	22.42	0.08	0	1902-1	QPSK	1	0	10 mm	back	1:1	0.687	1.019	0.700	A7
1732.50	20175	Mid	LTE Band 4 (AWS)	20	21.5	20.87	-0.07	1	1902-1	QPSK	50	0	10 mm	back	1:1	0.565	1.156	0.653	
1732.50	20175	Mid	LTE Band 4 (AWS)	20	22.5	22.42	-0.08	0	1902-1	QPSK	1	0	10 mm	front	1:1	0.641	1.019	0.653	
1732.50	20175	Mid	LTE Band 4 (AWS)	20	21.5	20.87	-0.03	1	1902-1	QPSK	50	0	10 mm	front	1:1	0.540	1.156	0.624	
1732.50	20175	Mid	LTE Band 4 (AWS)	20	22.5	22.42	-0.02	0	1902-1	QPSK	1	0	10 mm	top	1:1	0.539	1.019	0.549	
1732.50	20175	Mid	LTE Band 4 (AWS)	20	21.5	20.87	0.02	1	1902-1	QPSK	50	0	10 mm	top	1:1	0.382	1.156	0.442	
1732.50	20175	Mid	LTE Band 4 (AWS)	20	22.5	22.42	-0.02	0	1902-1	QPSK	1	0	10 mm	right	1:1	0.256	1.019	0.261	
1732.50	20175	Mid	LTE Band 4 (AWS)	20	21.5	20.87	0.01	1	1902-1	QPSK	50	0	10 mm	right	1:1	0.185	1.156	0.214	
1732.50	20175	Mid	LTE Band 4 (AWS)	20	22.5	22.42	0.04	0	1902-1	QPSK	1	0	10 mm	left	1:1	0.300	1.019	0.306	
1732.50	20175	Mid	LTE Band 4 (AWS)	20	21.5	20.87	0.01	1	1902-1	QPSK	50	0	10 mm	left	1:1	0.205	1.156	0.237	
ANSI / IEEE C95.1 1992 - SAFETY LIMIT										Body									
Spatial Peak										1.6 W/kg (mW/g)									
Uncontrolled Exposure/General Population										averaged over 1 gram									

**Table 10-5  
LTE Band 2 (PCS) Hotspot SAR**

MEASUREMENT RESULTS																			
FREQUENCY		Mode	Bandwidth [MHz]	Maximum Allowed Power [dBm]	Conducted Power [dBm]	Power Drift [dB]	MPR [dB]	Device Serial Number	Modulation	RB Size	RB Offset	Spacing	Side	Duty Cycle	SAR (1g)	Scaling Factor	Scaled SAR (1g)	Plot #	
MHz	Ch.														(W/kg)		(W/kg)		
1900.00	19100	High	LTE Band 2 (PCS)	20	22.5	22.44	0.02	0	1902-1	QPSK	1	0	10 mm	back	1:1	0.471	1.014	0.478	
1900.00	19100	High	LTE Band 2 (PCS)	20	21.5	21.40	0.01	1	1902-1	QPSK	50	0	10 mm	back	1:1	0.358	1.023	0.366	
1900.00	19100	High	LTE Band 2 (PCS)	20	22.5	22.44	-0.06	0	1902-1	QPSK	1	0	10 mm	front	1:1	0.587	1.014	0.595	A8
1900.00	19100	High	LTE Band 2 (PCS)	20	21.5	21.40	0.02	1	1902-1	QPSK	50	0	10 mm	front	1:1	0.432	1.023	0.442	
1900.00	19100	High	LTE Band 2 (PCS)	20	22.5	22.44	-0.10	0	1902-1	QPSK	1	0	10 mm	top	1:1	0.354	1.014	0.359	
1900.00	19100	High	LTE Band 2 (PCS)	20	21.5	21.40	0.00	1	1902-1	QPSK	50	0	10 mm	top	1:1	0.263	1.023	0.269	
1900.00	19100	High	LTE Band 2 (PCS)	20	22.5	22.44	0.11	0	1902-1	QPSK	1	0	10 mm	right	1:1	0.098	1.014	0.099	
1900.00	19100	High	LTE Band 2 (PCS)	20	21.5	21.40	0.01	1	1902-1	QPSK	50	0	10 mm	right	1:1	0.073	1.023	0.075	
1900.00	19100	High	LTE Band 2 (PCS)	20	22.5	22.44	0.12	0	1902-1	QPSK	1	0	10 mm	left	1:1	0.189	1.014	0.192	
1900.00	19100	High	LTE Band 2 (PCS)	20	21.5	21.40	0.02	1	1902-1	QPSK	50	0	10 mm	left	1:1	0.141	1.023	0.144	
ANSI / IEEE C95.1 1992 - SAFETY LIMIT										Body									
Spatial Peak										1.6 W/kg (mW/g)									
Uncontrolled Exposure/General Population										averaged over 1 gram									

**Table 10-6  
WLAN Hotspot SAR**

MEASUREMENT RESULTS															
FREQUENCY		Mode	Service	Maximum Allowed Power [dBm]	Conducted Power [dBm]	Power Drift [dB]	Spacing	Device Serial Number	Data Rate (Mbps)	Side	Duty Cycle	SAR (1g)	Scaling Factor	Scaled SAR (1g)	Plot #
MHz	Ch.											(W/kg)		(W/kg)	
2412	1	IEEE 802.11b	DSSS	17.5	17.09	0.12	10 mm	1902-3	1	back	1:1	0.048	1.099	0.053	
2412	1	IEEE 802.11b	DSSS	17.5	17.09	0.10	10 mm	1902-3	1	front	1:1	0.064	1.099	0.070	
2412	1	IEEE 802.11b	DSSS	17.5	17.09	0.11	10 mm	1902-3	1	bottom	1:1	0.078	1.099	0.086	A9
2412	1	IEEE 802.11b	DSSS	17.5	17.09	0.09	10 mm	1902-3	1	left	1:1	0.019	1.099	0.021	
ANSI / IEEE C95.1 1992 - SAFETY LIMIT										Body					
Spatial Peak										1.6 W/kg (mW/g)					
Uncontrolled Exposure/General Population										averaged over 1 gram					

## 10.2 SAR Test Notes

### General Notes:

1. The test data reported are the worst-case SAR values according to test procedures specified in KDB Publication 941225 D06v01r01 and FCC KDB Publication 447498 D01v05r01.
2. Batteries are fully charged at the beginning of the SAR measurements. A standard battery was used for all SAR measurements.
3. Liquid tissue depth was at least 15.0 cm for all frequencies.
4. The manufacturer has confirmed that the device(s) tested have the same physical, mechanical and thermal characteristics and are within operational tolerances expected for production units.
5. SAR results were scaled to the maximum allowed power to demonstrate compliance per FCC KDB Publication 447498 D01v05r01.
6. Per FCC KDB 865664 D01 v01r01, variability SAR tests were not performed since the measured SAR results for a frequency band was less than 0.8 W/kg. Please see Section 12 for variability analysis.
7. During SAR Testing for the Wireless Router conditions per FCC KDB Publication 941225 D06v01r01, the actual Portable Hotspot operation (with actual simultaneous transmission of a transmitter with WIFI) was not activated (See Section 5.2 for more details).

### GSM Test Notes:

1. Justification for reduced test configurations per KDB Publication 941225 D03v01: The source-based time-averaged output power was evaluated for all multi-slot operations. The multi-slot configuration with the highest frame averaged output power was evaluated for SAR for hotspot SAR.
2. Per FCC KDB Publication 447498 D01v05r01, when the reported (scaled) SAR measured at the middle channel for some test configurations is > 0.8 W/kg, testing at the other channels is required for such test configuration(s). Since the maximum output power variation across the required test channels is < ½ dB, middle channel was the default used.

### UMTS Notes:



1. UMTS mode in Body SAR was tested under RMC 12.2 kbps with HSPA Inactive per KDB Publication 941225 D01v02r02. HSPA SAR was not required since the average output power of the HSPA subtests was not more than 0.25 dB higher than the RMC level and SAR was less than 1.2 W/kg.
2. Per FCC KDB Publication 447498 D01v05r01, when the reported (scaled) SAR measured at the middle channel for some test configurations is > 0.8 W/kg, testing at the other channels is required for such test configuration(s). Since the maximum output power variation across the required test channels is > ½ dB, middle channel it the default used.

### LTE Notes:

1. LTE Considerations: LTE test configurations are determined according to SAR Evaluation Considerations for LTE Devices in FCC KDB Publication 941225 D05v02r02. The general test procedures used for testing can be found in Section 7.4.4.
2. MPR is permanently implemented for this device by the manufacturer. The specific manufacturer target MPR is indicated alongside the SAR results. MPR is enabled for this device, according to 3GPP TS36.101 Section 6.2.3 – 6.2.5 under Table 6.2.3-1.
3. A-MPR was disabled for all SAR tests by setting NS=01 on the base station simulator. SAR tests were performed with the same number of RB and RB offsets transmitting on all TTI frames (maximum TTI).

### WLAN Notes:

1. Justification for reduced test configurations for WIFI channels per KDB Publication 248227 D01v01r02 and October 2012 FCC/TCB Meeting Notes for 2.4 GHz WIFI: Highest average RF output power channel for the lowest data rate was selected for SAR evaluation in 802.11b. Other IEEE 802.11 modes (including 802.11g/n) were not investigated since the average output powers over all channels and data rates were not more than 0.25 dB higher than the tested channel in the lowest data rate of IEEE 802.11b mode.
2. WIFI transmission was verified using an uncalibrated spectrum analyzer.
3. Since the either the maximum extrapolated peak SAR of the zoom scan for the maximum output channel is <1.6 W/kg and the reported 1g averaged SAR is <0.8 W/kg, SAR testing on other default channels is not required.

FCC ID: A3LSMV101M		SAR EVALUATION REPORT		Reviewed by: Quality Manager
Document S/N: OY1402240465.A3L	Test Dates: 02/24/14 - 03/05/14	DUT Type: Portable Wireless Router	Page 37 of 45	

# 11 FCC MULTI-TX AND ANTENNA SAR CONSIDERATIONS

## 11.1 Introduction

The following procedures adopted from FCC KDB Publication 447498 D01v05r01 are applicable to devices with built-in unlicensed transmitters such as 802.11 b/g/n devices which may simultaneously transmit with the licensed transmitter.

## 11.2 Simultaneous Transmission Procedures



This device contains transmitters that may operate simultaneously. Therefore simultaneous transmission analysis is required. Per FCC KDB 447498 D01v05r01 IV.C.1.iii, simultaneous transmission SAR test exclusion may be applied when the sum of the 1-g SAR for all the simultaneous transmitting antennas in a specific a physical test configuration is  $\leq 1.6$  W/kg. When standalone SAR is not required to be measured, per FCC KDB 447498 D01v05r01 4.3.2 2), the following equation must be used to estimate the standalone 1g SAR for simultaneous transmission assessment involving that transmitter.

## 11.3 Body SAR Simultaneous Transmission Analysis

Per FCC KDB Publication 941225 D06v01r01, the devices edges with antennas more than 2.5 cm from edge are not required to be evaluated for SAR (“-”).

**Table 11-1**  
**Simultaneous Transmission Scenario (2.4 GHz Wireless Router at 1.0 cm)**



Simult Tx	Configuration	GPRS 850 SAR (W/kg)	2.4 GHz WLAN SAR (W/kg)	$\Sigma$ SAR (W/kg)	Simult Tx	Configuration	UMTS 850 SAR (W/kg)	2.4 GHz WLAN SAR (W/kg)	$\Sigma$ SAR (W/kg)
Body SAR	Back	0.664	0.053	0.717	Body SAR	Back	0.298	0.053	0.351
	Front	0.721	0.070	<b>0.791</b>		Front	0.334	0.070	<b>0.404</b>
	Top	0.132	-	0.132		Top	0.094	-	0.094
	Bottom	-	0.086	0.086		Bottom	-	0.086	0.086
	Right	0.171	-	0.171		Right	0.039	-	0.039
	Left	0.346	0.021	0.367		Left	0.137	0.021	0.158
Simult Tx	Configuration	GPRS 1900 SAR (W/kg)	2.4 GHz WLAN SAR (W/kg)	$\Sigma$ SAR (W/kg)	Simult Tx	Configuration	UMTS 1900 SAR (W/kg)	2.4 GHz WLAN SAR (W/kg)	$\Sigma$ SAR (W/kg)
Body SAR	Back	0.262	0.053	0.315	Body SAR	Back	0.752	0.053	0.805
	Front	0.323	0.070	<b>0.393</b>		Front	0.812	0.070	<b>0.882</b>
	Top	0.149	-	0.149		Top	0.402	-	0.402
	Bottom	-	0.086	0.086		Bottom	-	0.086	0.086
	Right	0.061	-	0.061		Right	0.161	-	0.161
	Left	0.118	0.021	0.139		Left	0.360	0.021	0.381

FCC ID: A3LSMV101M		<b>SAR EVALUATION REPORT</b>		<b>Reviewed by:</b> Quality Manager
<b>Document S/N:</b> 0Y1402240465.A3L	<b>Test Dates:</b> 02/24/14 - 03/05/14	<b>DUT Type:</b> Portable Wireless Router	Page 38 of 45	

Simult Tx	Configuration	LTE Band 17 SAR (W/kg)	2.4 GHz WLAN SAR (W/kg)	Σ SAR (W/kg)	Simult Tx	Configuration	LTE Band 5 (Cell) SAR (W/kg)	2.4 GHz WLAN SAR (W/kg)	Σ SAR (W/kg)
Body SAR	Back	0.512	0.053	0.565	Body SAR	Back	0.209	0.053	0.262
	Front	0.552	0.070	<b>0.622</b>		Front	0.237	0.070	<b>0.307</b>
	Top	0.171	-	0.171		Top	0.065	-	0.065
	Bottom	-	0.086	0.086		Bottom	-	0.086	0.086
	Right	0.121	-	0.121		Right	0.034	-	0.034
	Left	0.137	0.021	0.158		Left	0.126	0.021	0.147
Simult Tx	Configuration	LTE Band 4 (AWS) SAR (W/kg)	2.4 GHz WLAN SAR (W/kg)	Σ SAR (W/kg)	Simult Tx	Configuration	LTE Band 2 (PCS) SAR (W/kg)	2.4 GHz WLAN SAR (W/kg)	Σ SAR (W/kg)
Body SAR	Back	0.700	0.053	<b>0.753</b>	Body SAR	Back	0.478	0.053	0.531
	Front	0.653	0.070	0.723		Front	0.595	0.070	<b>0.665</b>
	Top	0.549	-	0.549		Top	0.359	-	0.359
	Bottom	-	0.086	0.086		Bottom	-	0.086	0.086
	Right	0.261	-	0.261		Right	0.099	-	0.099
	Left	0.306	0.021	0.327		Left	0.192	0.021	0.213

## 11.4 Simultaneous Transmission Conclusion

The above numerical summed SAR results for all the worst-case simultaneous transmission conditions were below the SAR limit. Therefore, the above analysis is sufficient to determine that simultaneous transmission cases will not exceed the SAR limit and therefore no measured volumetric simultaneous SAR summation is required per FCC KDB Publication 447498 D01v05r01.

FCC ID: A3LSMV101M		<b>SAR EVALUATION REPORT</b>		<b>Reviewed by:</b> Quality Manager
<b>Document S/N:</b> 0Y1402240465.A3L	<b>Test Dates:</b> 02/24/14 - 03/05/14	<b>DUT Type:</b> Portable Wireless Router	Page 39 of 45	



## 12 SAR MEASUREMENT VARIABILITY

### 12.1 Measurement Variability

Per FCC KDB Publication 865664 D01v01, SAR measurement variability was assessed when measured 1 gram SAR is  $> 0.80$  W/kg. Since all measured 1 gram SAR values were  $< 0.8$  W/kg for this device, SAR measurement variability was not assessed.

### 12.2 Measurement Uncertainty

The measured SAR was  $< 1.5$  W/kg for all frequency bands. Therefore, per KDB Publication 865664 D01v01r01, the extended measurement uncertainty analysis per IEEE 1528-2003 was not required.



FCC ID: A3LSMV101M	 <b>PCTEST</b> ENGINEERING LABORATORY, INC.	<b>SAR EVALUATION REPORT</b>		<b>Reviewed by:</b> Quality Manager
<b>Document S/N:</b> 0Y1402240465.A3L	<b>Test Dates:</b> 02/24/14 - 03/05/14	<b>DUT Type:</b> Portable Wireless Router	Page 40 of 45	

# 13 EQUIPMENT LIST

Manufacturer	Model	Description	Cal Date	Cal Interval	Cal Due	Serial Number
Gigatronics	80701A	(0.05-18GHz) Power Sensor	10/30/2013	Annual	10/30/2014	1833460
Agilent	E8257D	(250kHz-20GHz) Signal Generator	4/16/2013	Annual	4/16/2014	MY45470194
Agilent	8753E	(30kHz-6GHz) Network Analyzer	4/16/2013	Annual	4/16/2014	JP38020182
Agilent	8753E	(30kHz-6GHz) Network Analyzer	7/23/2013	Annual	7/23/2014	US37390350
Agilent	8594A	(9kHz-2.9GHz) Spectrum Analyzer	N/A	N/A	N/A	3051A00187
Agilent	8648D	(9kHz-4GHz) Signal Generator	4/17/2013	Annual	4/17/2014	3629U00687
SPEAG	D1750V2	1750 MHz SAR Dipole	4/30/2013	Annual	4/30/2014	1051
SPEAG	D1900V2	1900 MHz SAR Dipole	7/22/2013	Annual	7/22/2014	5d149
SPEAG	D2450V2	2450 MHz SAR Dipole	8/23/2013	Annual	8/23/2014	719
Narda	4014C-6	4 - 8 GHz SMA 6 dB Directional Coupler	CBT	N/A	CBT	N/A
Amplifier Research	SS1G4	5W, 800MHz-4.2GHz	CBT	N/A	CBT	21910
MCL	BW-N6W5+	6dB Attenuator	CBT	N/A	CBT	1139
SPEAG	D750V3	750 MHz Dipole	1/20/2014	Annual	1/20/2015	1003
SPEAG	D835V2	835 MHz SAR Dipole	4/25/2013	Annual	4/25/2014	4d119
Narda	4772-3	Attenuator (3dB)	CBT	N/A	CBT	9406
Narda	BW-S3W2	Attenuator (3dB)	CBT	N/A	CBT	120
Rohde & Schwarz	CMU200	Base Station Simulator	5/3/2013	Annual	5/3/2014	836371/0079
Pasternack	PE2208-6	Bidirectional Coupler	CBT	N/A	CBT	N/A
Pasternack	PE2209-10	Bidirectional Coupler	CBT	N/A	CBT	N/A
SPEAG	DAE4	Dasy Data Acquisition Electronics	3/8/2013	Annual	3/8/2014	1334
SPEAG	DAE4	Dasy Data Acquisition Electronics	2/26/2014	Annual	2/26/2015	665
SPEAG	DAE4	Dasy Data Acquisition Electronics	4/22/2013	Annual	4/22/2014	1364
Mini-Circuits	BW-N20W5+	DC to 18 GHz Precision Fixed 20 dB Attenuator	CBT	N/A	CBT	N/A
SPEAG	DAK-3.5	Dielectric Assessment Kit	5/14/2013	Annual	5/14/2014	1070
SPEAG	DAK-3.5	Dielectric Assessment Kit	11/13/2013	Annual	11/13/2014	1091
Rohde & Schwarz	NRVD	Dual Channel Power Meter	10/12/2012	Biennial	10/12/2014	101695
VWR	23226-658	Long Stem Thermometer	3/30/2012	Biennial	3/30/2014	122179874
VWR	23226-658	Long Stem Thermometer	5/16/2012	Biennial	5/16/2014	122295544
MiniCircuits	SLP-2400+	Low Pass Filter	CBT	N/A	CBT	R8979500903
Mini-Circuits	NLP-1200+	Low Pass Filter DC to 1000 MHz	CBT	N/A	CBT	N/A
Mini-Circuits	NLP-2950+	Low Pass Filter DC to 2700 MHz	CBT	N/A	CBT	N/A
Rohde & Schwarz	CMW500	LTE Radio Communication Tester	6/6/2013	Annual	6/6/2014	111427
Rohde & Schwarz	NRV-Z32	Peak Power Sensor	10/12/2012	Biennial	10/12/2014	836019/013
SPEAG	DAKS-3.5	Portable Dielectric Assessment Kit	8/18/2013	Annual	8/18/2014	1008
Mini-Circuits	BW-N20W5	Power Attenuator	CBT	N/A	CBT	1226
Anritsu	ML2495A	Power Meter	10/31/2013	Annual	10/31/2014	1039008
Anritsu	ML2469A	Power Meter	CBT	N/A	CBT	1306009
Anritsu	MA2481A	Power Sensor	10/30/2013	Annual	10/30/2014	5605
Anritsu	MA2411B	Pulse Power Sensor	11/14/2013	Annual	11/14/2014	1126066
Anritsu	MA2411B	Pulse Power Sensor	CBT	N/A	CBT	1207470
Anritsu	MT8820C	Radio Communication Analyzer	6/28/2013	Annual	6/28/2014	6201240328
Tektronix	RSA6114A	Real Time Spectrum Analyzer	4/17/2013	Annual	4/17/2014	B010177
SPEAG	ES3DV3	SAR Probe	3/15/2013	Annual	3/15/2014	3209
SPEAG	ES3DV3	SAR Probe	2/25/2014	Annual	2/25/2015	3258
SPEAG	ES3DV3	SAR Probe	4/29/2013	Annual	4/29/2014	3318
Rohde & Schwarz	SMIQ03B	Signal Generator	4/17/2013	Annual	4/17/2014	DE27259
Rohde & Schwarz	SME06	Signal Generator	10/30/2013	Annual	10/30/2014	832026
Rohde & Schwarz	NRVS	Single Channel Power Meter	10/31/2013	Annual	10/31/2014	835360/0079
COMTECH	AR85729-5/5759B	Solid State Amplifier	CBT	N/A	CBT	M3W1A00-1002
Agilent	8753ES	S-Parameter Network Analyzer	10/29/2013	Annual	10/29/2014	US39170122
Agilent	85047A	S-Parameter Test Set	N/A	N/A	N/A	2904A00579
Fisher Scientific	15-077-960	Thermometer	11/6/2012	Biennial	11/6/2014	122640025
Seekonk	NC-100	Torque Wrench (8" lb)	11/29/2011	Triennial	11/29/2014	21053
Gigatronics	8651A	Universal Power Meter	10/30/2013	Annual	10/30/2014	8650319
Anritsu	MA24106A	USB Power Sensor	1/3/2014	Annual	1/3/2015	1349501
Anritsu	MA24106A	USB Power Sensor	1/3/2014	Annual	1/3/2015	1349503
VWR	36934-158	Wall-Mounted Thermometer	8/8/2013	Annual	8/8/2014	130477877

Note:



1. CBT (Calibrated Before Testing). Prior to testing, the measurement paths containing a cable, amplifier, attenuator, coupler or filter were connected to a calibrated source (i.e. a signal generator) to determine the losses of the measurement path. The power meter offset was then adjusted to compensate for the measurement system losses. This level offset is stored within the power meter before measurements are made. This calibration verification procedure applies to the system verification and output power measurements. The calibrated reading is then taken directly from the power meter after compensation of the losses for all final power measurements.
2. All equipment was used solely within its calibration period.

FCC ID: A3LSMV101M	 PCTEST ENGINEERING LABORATORY, INC.	SAR EVALUATION REPORT		Reviewed by: Quality Manager
Document S/N: OY1402240465.A3L	Test Dates: 02/24/14 - 03/05/14	DUT Type: Portable Wireless Router	Page 41 of 45	

# 14 MEASUREMENT UNCERTAINTIES

a	b	c	d	e= f(d,k)	f	g	h = c x f/e	i = c x g/e	k	
Uncertainty Component	IEEE 1528 Sec.	Tol. (± %)	Prob. Dist.	Div.	c <sub>i</sub> 1gm	c <sub>i</sub> 10 gms	1gm u <sub>i</sub> (± %)	10gms u <sub>i</sub> (± %)	v <sub>i</sub>	
<b>Measurement System</b>										
Probe Calibration	E.2.1	6.0	N	1	1.0	1.0	6.0	6.0	∞	
Axial Isotropy	E.2.2	0.25	N	1	0.7	0.7	0.2	0.2	∞	
Hemishperical Isotropy	E.2.2	1.3	N	1	1.0	1.0	1.3	1.3	∞	
Boundary Effect	E.2.3	0.4	N	1	1.0	1.0	0.4	0.4	∞	
Linearity	E.2.4	0.3	N	1	1.0	1.0	0.3	0.3	∞	
System Detection Limits	E.2.5	5.1	N	1	1.0	1.0	5.1	5.1	∞	
Readout Electronics	E.2.6	1.0	N	1	1.0	1.0	1.0	1.0	∞	
Response Time	E.2.7	0.8	R	1.73	1.0	1.0	0.5	0.5	∞	
Integration Time	E.2.8	2.6	R	1.73	1.0	1.0	1.5	1.5	∞	
RF Ambient Conditions	E.6.1	3.0	R	1.73	1.0	1.0	1.7	1.7	∞	
Probe Positioner Mechanical Tolerance	E.6.2	0.4	R	1.73	1.0	1.0	0.2	0.2	∞	
Probe Positioning w/ respect to Phantom	E.6.3	2.9	R	1.73	1.0	1.0	1.7	1.7	∞	
Extrapolation, Interpolation & Integration algorithms for Max. SAR Evaluation	E.5	1.0	R	1.73	1.0	1.0	0.6	0.6	∞	
<b>Test Sample Related</b>										
Test Sample Positioning	E.4.2	6.0	N	1	1.0	1.0	6.0	6.0	287	
Device Holder Uncertainty	E.4.1	3.32	R	1.73	1.0	1.0	1.9	1.9	∞	
Output Power Variation - SAR drift measurement	6.6.2	5.0	R	1.73	1.0	1.0	2.9	2.9	∞	
<b>Phantom &amp; Tissue Parameters</b>										
Phantom Uncertainty (Shape & Thickness tolerances)	E.3.1	4.0	R	1.73	1.0	1.0	2.3	2.3	∞	
Liquid Conductivity - deviation from target values	E.3.2	5.0	R	1.73	0.64	0.43	1.8	1.2	∞	
Liquid Conductivity - measurement uncertainty	E.3.3	3.8	N	1	0.64	0.43	2.4	1.6	6	
Liquid Permittivity - deviation from target values	E.3.2	5.0	R	1.73	0.60	0.49	1.7	1.4	∞	
Liquid Permittivity - measurement uncertainty	E.3.3	4.5	N	1	0.60	0.49	2.7	2.2	6	
<b>Combined Standard Uncertainty (k=1)</b>							RSS	12.1	11.7	299
<b>Expanded Uncertainty</b> (95% CONFIDENCE LEVEL)							k=2	24.2	23.5	

The above measurement uncertainties are according to IEEE Std. 1528-2003



FCC ID: A3LSMV101M	 <b>PCTEST</b> ENGINEERING LABORATORY, INC.	<b>SAR EVALUATION REPORT</b>		<b>Reviewed by:</b> Quality Manager
<b>Document S/N:</b> OY1402240465.A3L	<b>Test Dates:</b> 02/24/14 - 03/05/14	<b>DUT Type:</b> Portable Wireless Router		Page 42 of 45

# 15 CONCLUSION

## 15.1 Measurement Conclusion



The SAR evaluation indicates that the EUT complies with the RF radiation exposure limits of the FCC and Industry Canada, with respect to all parameters subject to this test. These measurements were taken to simulate the RF effects of RF exposure under worst-case conditions. Precise laboratory measures were taken to assure repeatability of the tests. The results and statements relate only to the item(s) tested.

Please note that the absorption and distribution of electromagnetic energy in the body are very complex phenomena that depend on the mass, shape, and size of the body, the orientation of the body with respect to the field vectors, and the electrical properties of both the body and the environment. Other variables that may play a substantial role in possible biological effects are those that characterize the environment (e.g. ambient temperature, air velocity, relative humidity, and body insulation) and those that characterize the individual (e.g. age, gender, activity level, debilitation, or disease). Because various factors may interact with one another to vary the specific biological outcome of an exposure to electromagnetic fields, any protection guide should consider maximal amplification of biological effects as a result of field-body interactions, environmental conditions, and physiological variables. [3]



<b>FCC ID:</b> A3LSMV101M		<b>SAR EVALUATION REPORT</b>		<b>Reviewed by:</b> Quality Manager
<b>Document S/N:</b> 0Y1402240465.A3L	<b>Test Dates:</b> 02/24/14 - 03/05/14	<b>DUT Type:</b> Portable Wireless Router	Page 43 of 45	

## 16 REFERENCES

- [1] Federal Communications Commission, ET Docket 93-62, Guidelines for Evaluating the Environmental Effects of Radiofrequency Radiation, Aug. 1996.
- [2] ANSI/IEEE C95.1-2005, American National Standard safety levels with respect to human exposure to radio frequency electromagnetic fields, 3kHz to 300GHz, New York: IEEE, 2006.
- [3] ANSI/IEEE C95.1-1992, American National Standard safety levels with respect to human exposure to radio frequency electromagnetic fields, 3kHz to 300GHz, New York: IEEE, Sept. 1992.
- [4] ANSI/IEEE C95.3-2002, IEEE Recommended Practice for the Measurement of Potentially Hazardous Electromagnetic Fields - RF and Microwave, New York: IEEE, December 2002.
- [5] Federal Communications Commission, OET Bulletin 65 (Edition 97-01), Supplement C (Edition 01-01), Evaluating Compliance with FCC Guidelines for Human Exposure to Radiofrequency Electromagnetic Fields, June 2001.
- [6] IEEE Standards Coordinating Committee 34 – IEEE Std. 1528-2003, Recommended Practice for Determining the Peak Spatial-Average Specific Absorption Rate (SAR) in the Human Body Due to Wireless Communications Devices.
- [7] NCRP, National Council on Radiation Protection and Measurements, Biological Effects and Exposure Criteria for RadioFrequency Electromagnetic Fields, NCRP Report No. 86, 1986. Reprinted Feb. 1995.
- [8] T. Schmid, O. Egger, N. Kuster, Automated E-field scanning system for dosimetric assessments, IEEE Transaction on Microwave Theory and Techniques, vol. 44, Jan. 1996, pp. 105-113.
- [9] K. Pokovic, T. Schmid, N. Kuster, Robust setup for precise calibration of E-field probes in tissue simulating liquids at mobile communications frequencies, ICECOM97, Oct. 1997, pp. -124.
- [10] K. Pokovic, T. Schmid, and N. Kuster, E-field Probe with improved isotropy in brain simulating liquids, Proceedings of the ELMAR, Zadar, Croatia, June 23-25, 1996, pp. 172-175.
- [11] Schmid & Partner Engineering AG, Application Note: Data Storage and Evaluation, June 1998, p2.
- [12] V. Hombach, K. Meier, M. Burkhardt, E. Kuhn, N. Kuster, The Dependence of EM Energy Absorption upon Human Modeling at 900 MHz, IEEE Transaction on Microwave Theory and Techniques, vol. 44 no. 10, Oct. 1996, pp. 1865-1873.
- [13] N. Kuster and Q. Balzano, Energy absorption mechanism by biological bodies in the near field of dipole antennas above 300MHz, IEEE Transaction on Vehicular Technology, vol. 41, no. 1, Feb. 1992, pp. 17-23.
- [14] G. Hartsgrrove, A. Kraszewski, A. Surowiec, Simulated Biological Materials for Electromagnetic Radiation Absorption Studies, University of Ottawa, Bioelectromagnetics, Canada: 1987, pp. 29-36.
- [15] Q. Balzano, O. Garay, T. Manning Jr., Electromagnetic Energy Exposure of Simulated Users of Portable Cellular Telephones, IEEE Transactions on Vehicular Technology, vol. 44, no.3, Aug. 1995.
- [16] W. Gander, Computermathematik, Birkhaeuser, Basel, 1992.
- [17] W.H. Press, S.A. Teukolsky, W.T. Vetterling, and B.P. Flannery, Numerical Recipes in C, The Art of Scientific Computing, Second edition, Cambridge University Press, 1992.

FCC ID: A3LSMV101M		SAR EVALUATION REPORT		Reviewed by: Quality Manager
Document S/N: OY1402240465.A3L	Test Dates: 02/24/14 - 03/05/14	DUT Type: Portable Wireless Router		Page 44 of 45

- [18] Federal Communications Commission, OET Bulletin 65, Evaluating Compliance with FCC Guidelines for Human Exposure to Radiofrequency Electromagnetic Fields. Supplement C, Dec. 1997.
- [19] N. Kuster, R. Kastle, T. Schmid, Dosimetric evaluation of mobile communications equipment with known precision, IEEE Transaction on Communications, vol. E80-B, no. 5, May 1997, pp. 645-652.
- [20] CENELEC CLC/SC111B, European Prestandard (prENV 50166-2), Human Exposure to Electromagnetic Fields High-frequency: 10kHz-300GHz, Jan. 1995.
- [21] Prof. Dr. Niels Kuster, ETH, Eidgenössische Technische Hochschule Zürich, Dosimetric Evaluation of the Cellular Phone.
- [22] IEC 62209-1, Human exposure to radio frequency fields from hand-held and body-mounted wireless communication devices - Human models, instrumentation, and procedures - Part 1: Procedure to determine the specific absorption rate (SAR) for hand-held devices used in close proximity to the ear (frequency range of 300 MHz to 3 GHz), Feb. 2005.
- [23] Industry Canada RSS-102 Radio Frequency Exposure Compliance of Radiocommunication Apparatus (All Frequency Bands) Issue 4, March 2010.
- [24] Health Canada Safety Code 6 Limits of Human Exposure to Radio Frequency Electromagnetic Fields in the Frequency Range from 3 kHz – 300 GHz, 2009
- [25] FCC Public Notice DA-02-1438. Office of Engineering and Technology Announces a Transition Period for the Phantom Requirements of Supplement C to OET Bulletin 65, June 19, 2002
- [26] FCC SAR Test Procedures for 2G-3G Devices, Mobile Hotspot and UMPC Devices KDB Publications 941225, D01-D07
- [27] SAR Measurement procedures for IEEE 802.11a/b/g KDB Publication 248227 D01v01r02
- [28] FCC SAR Considerations for Handsets with Multiple Transmitters and Antennas, KDB Publications 648474 D03-D04
- [29] FCC SAR Evaluation Considerations for Laptop, Notebook, Netbook and Tablet Computers, FCC KDB Publication 616217 D04
- [30] FCC SAR Measurement and Reporting Requirements for 100MHz – 6 GHz, KDB Publications 865664 D01-D02
- [31] FCC General RF Exposure Guidance and SAR Procedures for Dongles, KDB Publication 447498, D01-D02
- [32] Anexo à Resolução No. 533, de 10 de Setembro de 2009.
- [33] IEC 62209-2, Human exposure to radio frequency fields from hand-held and body-mounted wireless communication devices - Human models, instrumentation, and procedures - Part 2: Procedure to determine the specific absorption rate (SAR) for wireless communication devices used in close proximity to the human body (frequency range of 30 MHz to 6 GHz), Mar. 2010.

<b>FCC ID:</b> A3LSMV101M		<b>SAR EVALUATION REPORT</b>		<b>Reviewed by:</b> Quality Manager
<b>Document S/N:</b> 0Y1402240465.A3L	<b>Test Dates:</b> 02/24/14 - 03/05/14	<b>DUT Type:</b> Portable Wireless Router	Page 45 of 45	

## APPENDIX A: SAR TEST DATA

# PCTEST ENGINEERING LABORATORY, INC.

**DUT: A3LSMV101M; Type: Portable Wireless Router; Serial: 1902-1**

Communication System: UID 0, GSM GPRS; 2 Tx slots; Frequency: 836.6 MHz; Duty Cycle: 1:4.15

Medium: 835 Body, Medium parameters used (interpolated):

$f = 836.6 \text{ MHz}$ ;  $\sigma = 1.001 \text{ S/m}$ ;  $\epsilon_r = 53.304$ ;  $\rho = 1000 \text{ kg/m}^3$

Phantom section: Flat Section; Space: 1.0 cm

Test Date: 02-27-2014; Ambient Temp: 24.4°C; Tissue Temp: 22.9°C

Probe: ES3DV3 - SN3209; ConvF(6.28, 6.28, 6.28); Calibrated: 3/15/2013;

Sensor-Surface: 4mm (Mechanical Surface Detection)

Electronics: DAE4 Sn1334; Calibrated: 3/8/2013

Phantom: ELI v5.0; Type: QDOVA002AA; Serial: TP-1158

Measurement SW: DASY52, Version 52.8 (7); SEMCAD X Version 14.6.10 (7164)

**Mode: GPRS 850, Body SAR, Front side, Mid.ch, 2 Tx Slots**

**Area Scan (8x10x1):** Measurement grid: dx=15mm, dy=15mm

**Zoom Scan (5x5x7)/Cube 0:** Measurement grid: dx=8mm, dy=8mm, dz=5mm

Reference Value = 25.497 V/m; Power Drift = 0.03 dB

Peak SAR (extrapolated) = 0.940 W/kg

**SAR(1 g) = 0.621 W/kg**

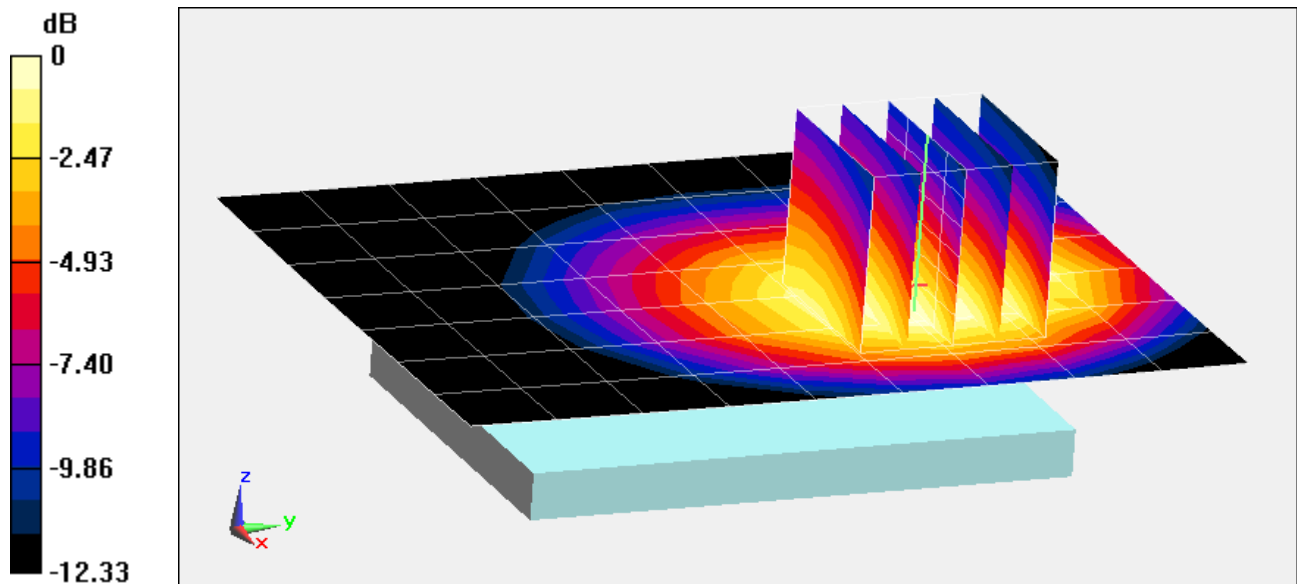

0 dB = 0.673 W/kg = -1.72 dBW/kg

# PCTEST ENGINEERING LABORATORY, INC.

**DUT: A3LSMV101M; Type: Portable Wireless Router; Serial: 1902-2**

Communication System: UID 0, UMTS; Frequency: 836.6 MHz; Duty Cycle: 1:1

Medium: 835 Body, Medium parameters used (interpolated):

$f = 836.6 \text{ MHz}$ ;  $\sigma = 1.001 \text{ S/m}$ ;  $\epsilon_r = 53.304$ ;  $\rho = 1000 \text{ kg/m}^3$

Phantom section: Flat Section; Space: 1.0 cm

Test Date: 02-27-2014; Ambient Temp: 24.4°C; Tissue Temp: 22.9°C

Probe: ES3DV3 - SN3209; ConvF(6.28, 6.28, 6.28); Calibrated: 3/15/2013;

Sensor-Surface: 4mm (Mechanical Surface Detection)

Electronics: DAE4 Sn1334; Calibrated: 3/8/2013

Phantom: ELI v5.0; Type: QDOVA002AA; Serial: TP-1158

Measurement SW: DASY52, Version 52.8 (7); SEMCAD X Version 14.6.10 (7164)

**Mode: UMTS 850, Body SAR, Front side, Mid.ch**

**Area Scan (8x10x1):** Measurement grid: dx=15mm, dy=15mm

**Zoom Scan (5x5x7)/Cube 0:** Measurement grid: dx=8mm, dy=8mm, dz=5mm

Reference Value = 17.425 V/m; Power Drift = 0.07 dB

Peak SAR (extrapolated) = 0.454 W/kg

**SAR(1 g) = 0.292 W/kg**

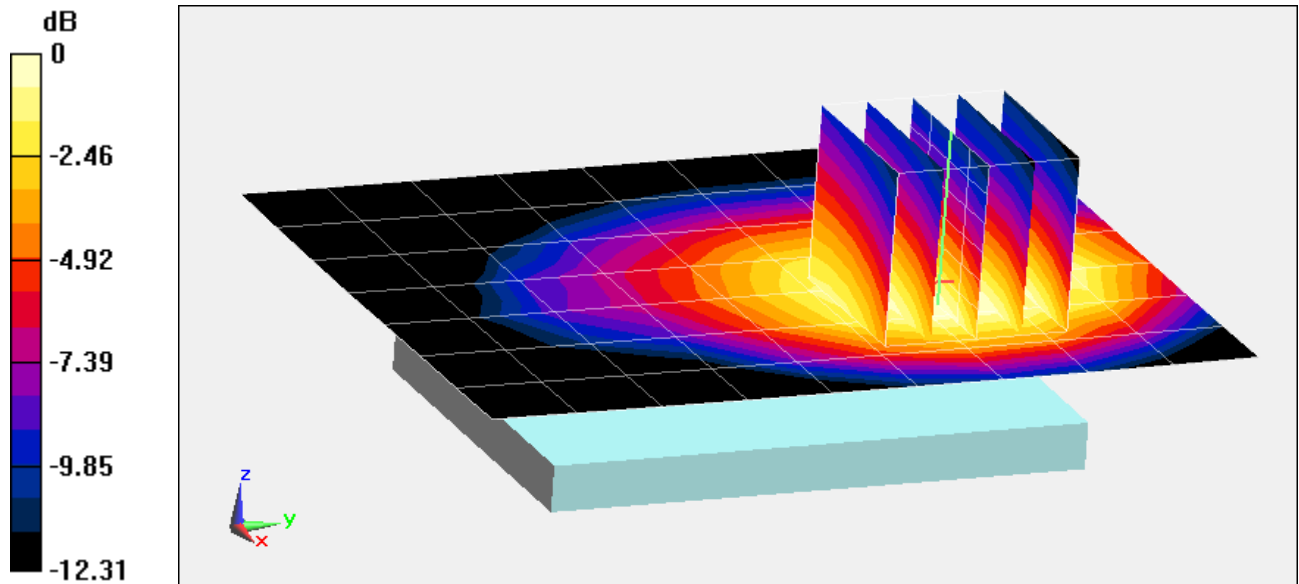

0 dB = 0.317 W/kg = -4.99 dBW/kg

# PCTEST ENGINEERING LABORATORY, INC.

**DUT: A3LSMV101M; Type: Portable Wireless Router; Serial: 1902-1**

Communication System: UID 0, GSM GPRS; 2 Tx slots; Frequency: 1880 MHz; Duty Cycle: 1:4.15  
Medium: 1900 Body, Medium parameters used:

$$f = 1880 \text{ MHz}; \sigma = 1.515 \text{ S/m}; \epsilon_r = 51.631; \rho = 1000 \text{ kg/m}^3$$

Phantom section: Flat Section; Space: 1.0 cm

Test Date: 02-24-2014; Ambient Temp: 24.4°C; Tissue Temp: 23.0°C

Probe: ES3DV3 - SN3209; ConvF(4.77, 4.77, 4.77); Calibrated: 3/15/2013;

Sensor-Surface: 4mm (Mechanical Surface Detection)

Electronics: DAE4 Sn1334; Calibrated: 3/8/2013

Phantom: SAM Front; Type: SAM; Serial: 1686

Measurement SW: DASY52, Version 52.8 (7); SEMCAD X Version 14.6.10 (7164)

**Mode: GPRS 1900, Body SAR, Front side, Mid.ch, 2 Tx Slots**

**Area Scan (8x10x1):** Measurement grid: dx=15mm, dy=15mm

**Zoom Scan (5x5x7)/Cube 0:** Measurement grid: dx=8mm, dy=8mm, dz=5mm

Reference Value = 15.570 V/m; Power Drift = -0.03 dB

Peak SAR (extrapolated) = 0.519 W/kg

**SAR(1 g) = 0.319 W/kg**

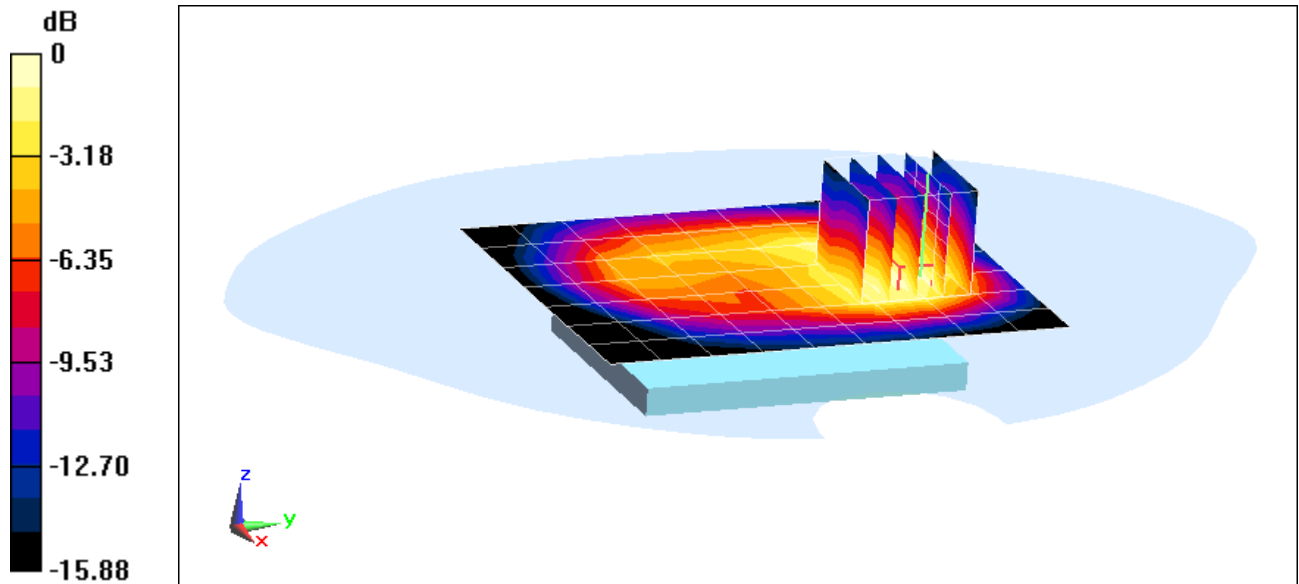

$$0 \text{ dB} = 0.336 \text{ W/kg} = -4.74 \text{ dBW/kg}$$

# PCTEST ENGINEERING LABORATORY, INC.

**DUT: A3LSMV101M; Type: Portable Wireless Router; Serial: 1902-2**

Communication System: UID 0, UMTS; Frequency: 1880 MHz; Duty Cycle: 1:1  
Medium: 1900 Body, Medium parameters used:

$f = 1880 \text{ MHz}$ ;  $\sigma = 1.515 \text{ S/m}$ ;  $\epsilon_r = 51.631$ ;  $\rho = 1000 \text{ kg/m}^3$

Phantom section: Flat Section; Space: 1.0 cm

Test Date: 02-24-2014; Ambient Temp: 24.4°C; Tissue Temp: 23.0°C

Probe: ES3DV3 - SN3209; ConvF(4.77, 4.77, 4.77); Calibrated: 3/15/2013;

Sensor-Surface: 4mm (Mechanical Surface Detection)

Electronics: DAE4 Sn1334; Calibrated: 3/8/2013

Phantom: SAM Front; Type: SAM; Serial: 1686

Measurement SW: DASY52, Version 52.8 (7); SEMCAD X Version 14.6.10 (7164)

**Mode: UMTS 1900, Body SAR, Front side, Mid.ch**

**Area Scan (8x12x1):** Measurement grid: dx=15mm, dy=15mm

**Zoom Scan (5x5x7)/Cube 0:** Measurement grid: dx=8mm, dy=8mm, dz=5mm

Reference Value = 22.113 V/m; Power Drift = -0.01 dB

Peak SAR (extrapolated) = 1.07 W/kg

**SAR(1 g) = 0.652 W/kg**

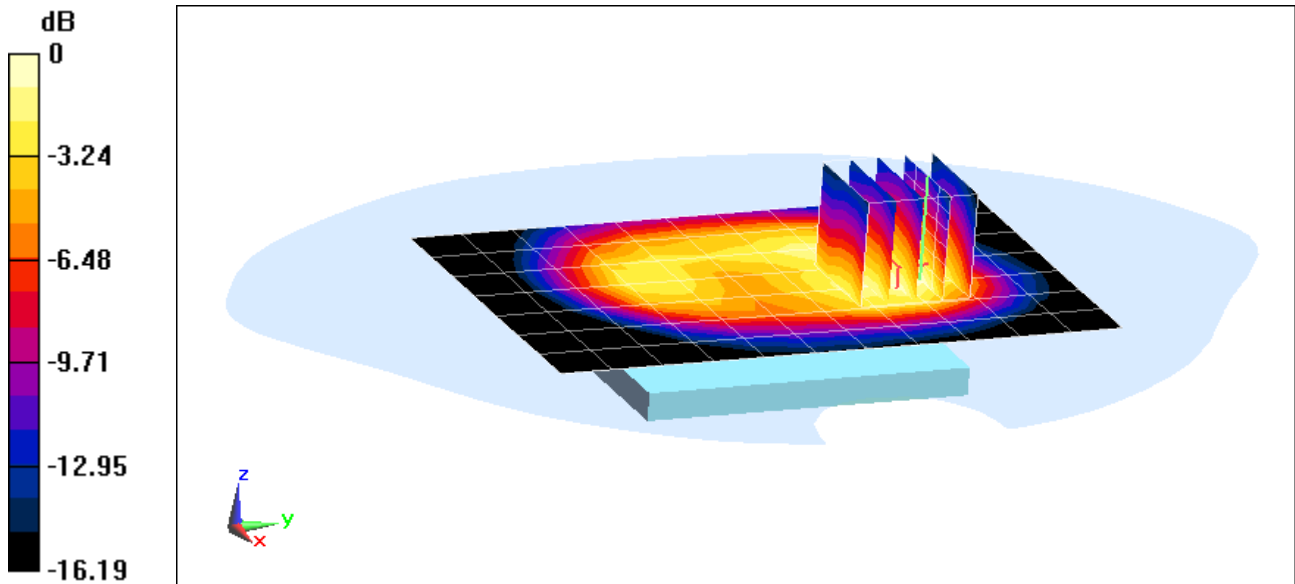

0 dB = 0.695 W/kg = -1.58 dBW/kg

# PCTEST ENGINEERING LABORATORY, INC.

**DUT: A3LSMV101M; Type: Portable Wireless Router; Serial: 1902-3**

Communication System: UID 0, LTE Band 17; Frequency: 710 MHz; Duty Cycle: 1:1

Medium: 740 Body, Medium parameters used:

$f = 710 \text{ MHz}$ ;  $\sigma = 0.945 \text{ S/m}$ ;  $\epsilon_r = 53.69$ ;  $\rho = 1000 \text{ kg/m}^3$

Phantom section: Flat Section; Space: 1.0 cm

Test Date: 02-28-2014; Ambient Temp: 23.6°C; Tissue Temp: 21.8°C

Probe: ES3DV3 - SN3318; ConvF(6.35, 6.35, 6.35); Calibrated: 4/29/2013;

Sensor-Surface: 4mm (Mechanical Surface Detection)

Electronics: DAE4 Sn1364; Calibrated: 4/22/2013

Phantom: ELI left; Type: QDOVA002AA; Serial: TP:1202

Measurement SW: DASY52, Version 52.8 (7); SEMCAD X Version 14.6.10 (7164)

**Mode: LTE Band 17, Body SAR, Front side, Mid.ch,  
10 MHz Bandwidth, QPSK, 1 RB, 49 RB Offset**

**Area Scan (8x10x1):** Measurement grid: dx=15mm, dy=15mm

**Zoom Scan (5x5x7)/Cube 0:** Measurement grid: dx=8mm, dy=8mm, dz=5mm

Reference Value = 25.584 V/m; Power Drift = 0.00 dB

Peak SAR (extrapolated) = 0.872 W/kg

**SAR(1 g) = 0.552 W/kg**

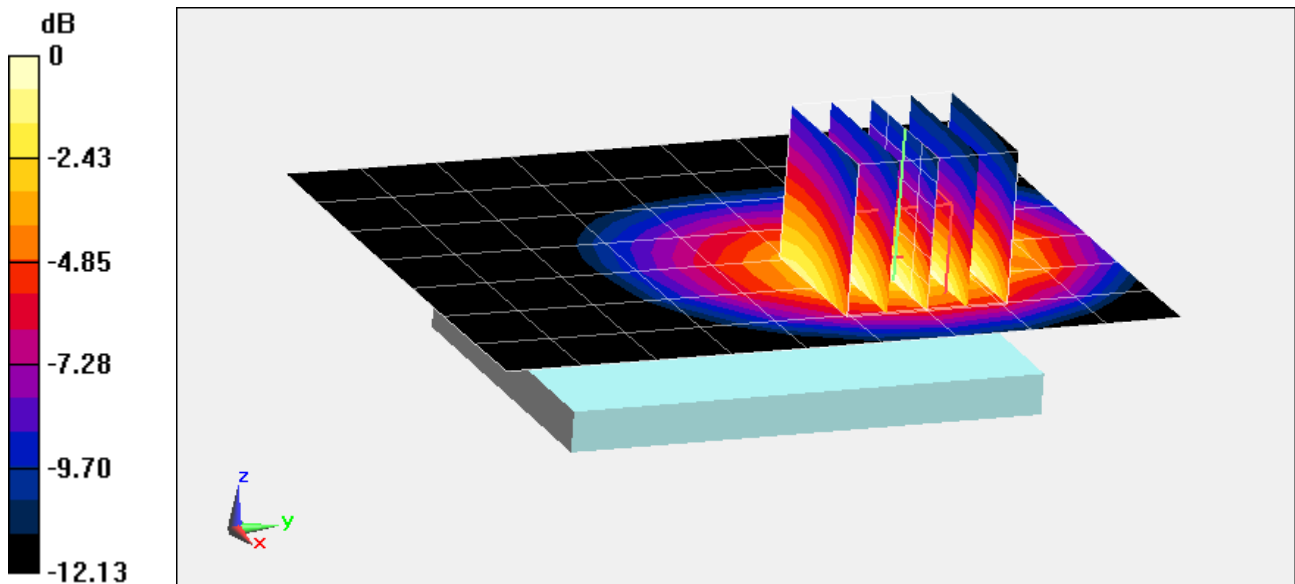

0 dB = 0.600 W/kg = -2.22 dBW/kg

# PCTEST ENGINEERING LABORATORY, INC.

**DUT: A3LSMV101M; Type: Portable Wireless Router; Serial: 1902-3**

Communication System: UID 0, LTE Band 5 (Cell.); Frequency: 836.5 MHz; Duty Cycle: 1:1  
Medium: 835 Body, Medium parameters used (interpolated):

$f = 836.5 \text{ MHz}$ ;  $\sigma = 1 \text{ S/m}$ ;  $\epsilon_r = 53.305$ ;  $\rho = 1000 \text{ kg/m}^3$

Phantom section: Flat Section; Space: 1.0 cm

Test Date: 02-27-2014; Ambient Temp: 24.4°C; Tissue Temp: 22.9°C

Probe: ES3DV3 - SN3209; ConvF(6.28, 6.28, 6.28); Calibrated: 3/15/2013;

Sensor-Surface: 4mm (Mechanical Surface Detection)

Electronics: DAE4 Sn1334; Calibrated: 3/8/2013

Phantom: ELI v5.0; Type: QDOVA002AA; Serial: TP-1158

Measurement SW: DASY52, Version 52.8 (7); SEMCAD X Version 14.6.10 (7164)

**Mode: LTE Band 5 (Cell.), Body SAR, Front side, Mid.ch,  
10 MHz Bandwidth, QPSK, 1 RB, 0 RB Offset**

**Area Scan (8x10x1):** Measurement grid: dx=15mm, dy=15mm

**Zoom Scan (5x5x7)/Cube 0:** Measurement grid: dx=8mm, dy=8mm, dz=5mm

Reference Value = 15.427 V/m; Power Drift = 0.00 dB

Peak SAR (extrapolated) = 0.329 W/kg

**SAR(1 g) = 0.212 W/kg**

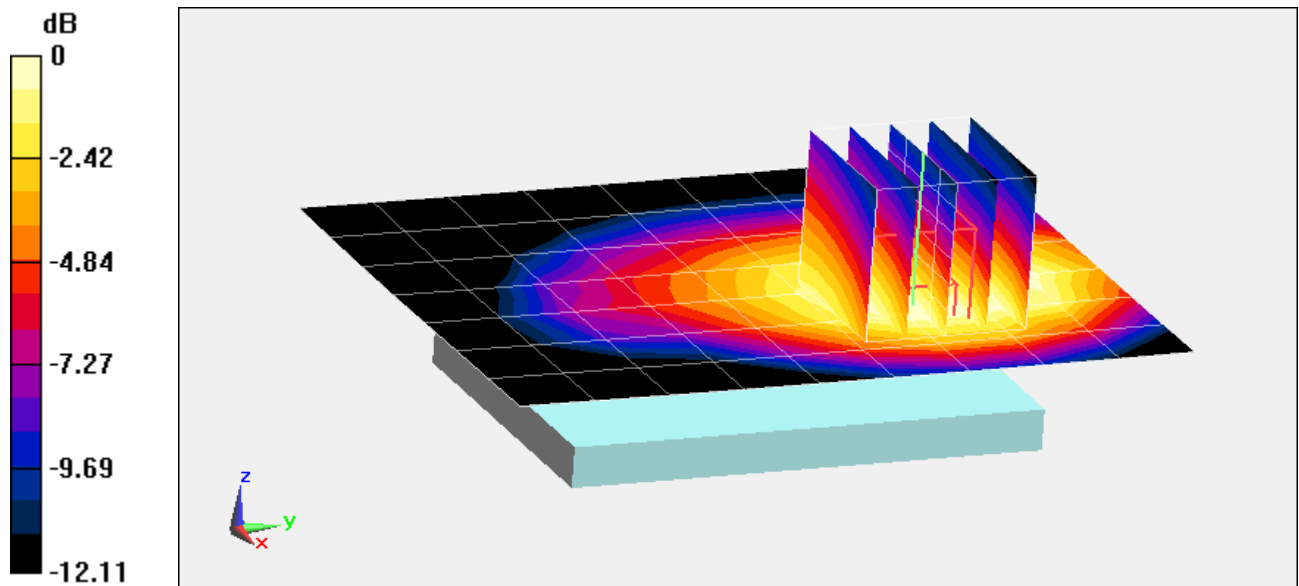

0 dB = 0.229 W/kg = -6.40 dBW/kg

# PCTEST ENGINEERING LABORATORY, INC.

**DUT: A3LSMV101M; Type: Portable Wireless Router; Serial: 1902-1**

Communication System: UID 0, LTE Band 4 (AWS); Frequency: 1732.5 MHz; Duty Cycle: 1:1  
Medium: 1750 Body, Medium parameters used (interpolated):

$f = 1732.5 \text{ MHz}$ ;  $\sigma = 1.457 \text{ S/m}$ ;  $\epsilon_r = 51.628$ ;  $\rho = 1000 \text{ kg/m}^3$

Phantom section: Flat Section; Space: 1.0 cm

Test Date: 02-24-2014; Ambient Temp: 24.4°C; Tissue Temp: 23.0°C

Probe: ES3DV3 - SN3209; ConvF(5.03, 5.03, 5.03); Calibrated: 3/15/2013;

Sensor-Surface: 4mm (Mechanical Surface Detection)

Electronics: DAE4 Sn1334; Calibrated: 3/8/2013

Phantom: ELI v5.0; Type: QDOVA002AA; Serial: TP-1158

Measurement SW: DASY52, Version 52.8 (7); SEMCAD X Version 14.6.10 (7164)

**Mode: LTE Band 4 (AWS), Body SAR, Back side, Mid.ch,  
20 MHz Bandwidth, QPSK, 1 RB, 0 RB Offset**

**Area Scan (8x10x1):** Measurement grid: dx=15mm, dy=15mm

**Zoom Scan (5x5x7)/Cube 0:** Measurement grid: dx=8mm, dy=8mm, dz=5mm

Reference Value = 23.058 V/m; Power Drift = 0.08 dB

Peak SAR (extrapolated) = 1.15 W/kg

**SAR(1 g) = 0.687 W/kg**

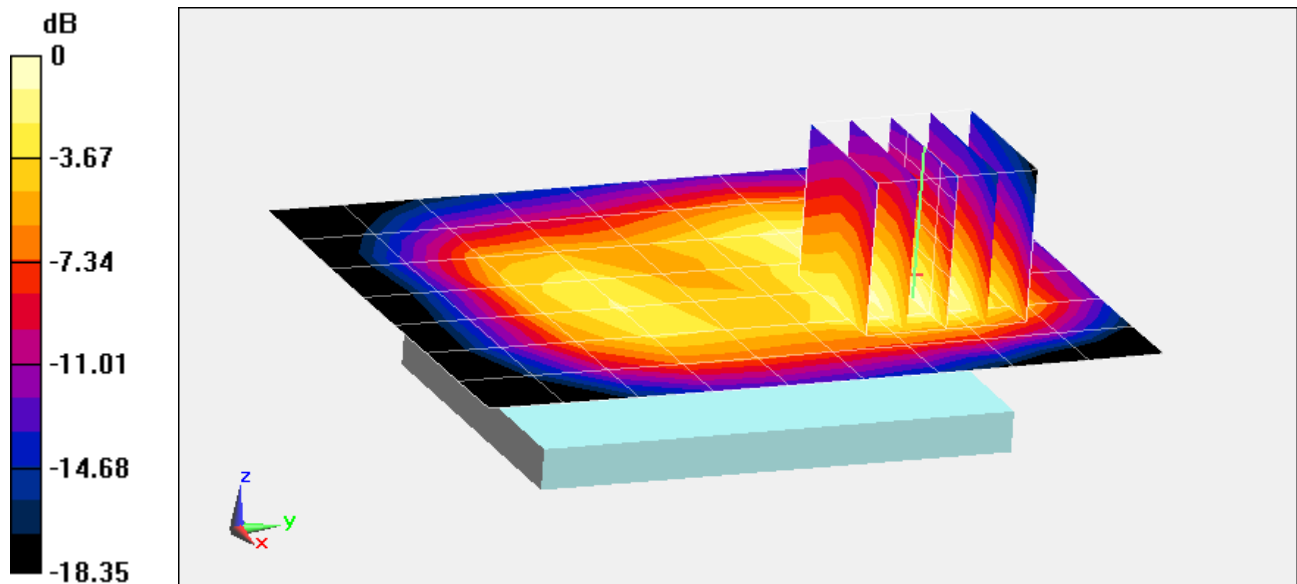

0 dB = 0.755 W/kg = -1.22 dBW/kg

# PCTEST ENGINEERING LABORATORY, INC.

**DUT: A3LSMV101M; Type: Portable Wireless Router; Serial: 1902-1**

Communication System: UID 0, LTE Band 2 (PCS); Frequency: 1900 MHz; Duty Cycle: 1:1

Medium: 1900 Body, Medium parameters used (interpolated):

$f = 1900 \text{ MHz}$ ;  $\sigma = 1.539 \text{ S/m}$ ;  $\epsilon_r = 51.56$ ;  $\rho = 1000 \text{ kg/m}^3$

Phantom section: Flat Section; Space: 1.0 cm

Test Date: 02-24-2014; Ambient Temp: 24.4°C; Tissue Temp: 23.0°C

Probe: ES3DV3 - SN3209; ConvF(4.77, 4.77, 4.77); Calibrated: 3/15/2013;

Sensor-Surface: 4mm (Mechanical Surface Detection)

Electronics: DAE4 Sn1334; Calibrated: 3/8/2013

Phantom: SAM Front; Type: SAM; Serial: 1686

Measurement SW: DASY52, Version 52.8 (7); SEMCAD X Version 14.6.10 (7164)

**Mode: LTE Band 2 (PCS), Body SAR, Front side, High.ch,  
20 MHz Bandwidth, QPSK, 1 RB, 0 RB Offset**

**Area Scan (8x10x1):** Measurement grid: dx=15mm, dy=15mm

**Zoom Scan (5x5x7)/Cube 0:** Measurement grid: dx=8mm, dy=8mm, dz=5mm

Reference Value = 20.437 V/m; Power Drift = -0.06 dB

Peak SAR (extrapolated) = 0.963 W/kg

**SAR(1 g) = 0.587 W/kg**

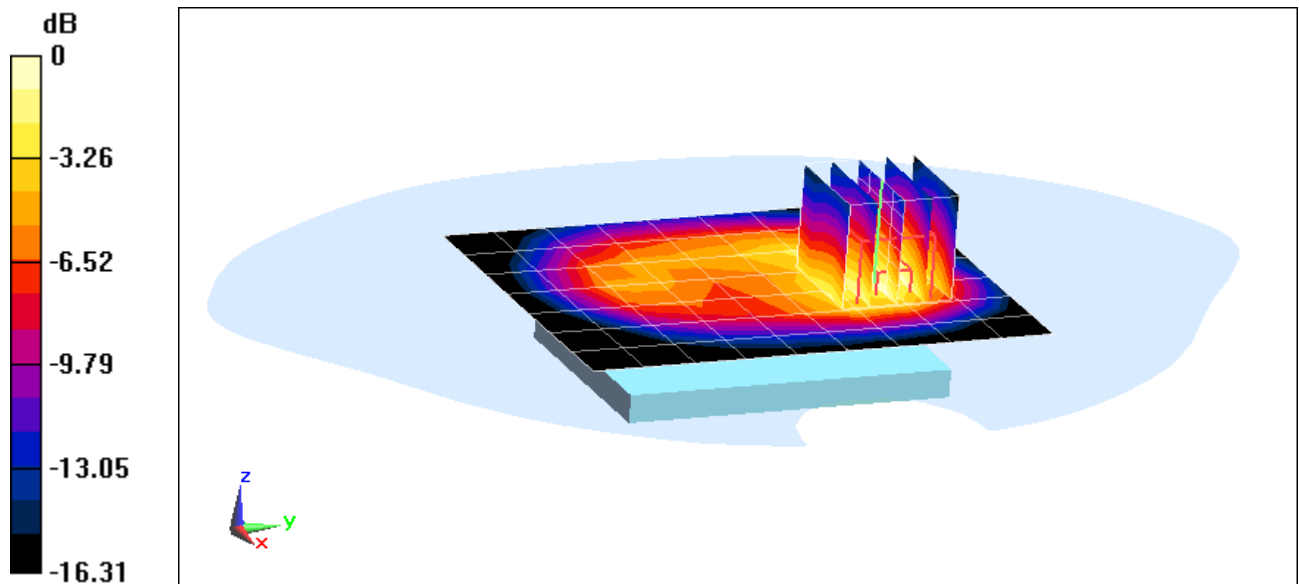

0 dB = 0.621 W/kg = -2.07 dBW/kg

# PCTEST ENGINEERING LABORATORY, INC.

**DUT: A3LSMV101M; Type: Portable Wireless Router; Serial: 1902-3**

Communication System: UID 0, IEEE 802.11b; Frequency: 2412 MHz; Duty Cycle: 1:1

Medium: 2450 Body, Medium parameters used (interpolated):

$f = 2412 \text{ MHz}$ ;  $\sigma = 1.988 \text{ S/m}$ ;  $\epsilon_r = 51.461$ ;  $\rho = 1000 \text{ kg/m}^3$

Phantom section: Flat Section; Space: 1.0 cm

Test Date: 03-05-2014; Ambient Temp: 24.3°C; Tissue Temp: 23.3°C

Probe: ES3DV3 - SN3258; ConvF(4.14, 4.14, 4.14); Calibrated: 2/25/2014;

Sensor-Surface: 3mm (Mechanical Surface Detection)

Electronics: DAE4 Sn665; Calibrated: 2/26/2014

Phantom: ELI v5.0; Type: QDOVA002AA; Serial: TP-1158

Measurement SW: DASY52, Version 52.8 (7); SEMCAD X Version 14.6.10 (7164)

**Mode: IEEE 802.11b, Body SAR, Ch 01, 1 Mbps, Bottom Edge**

**Area Scan (10x10x1):** Measurement grid: dx=5mm, dy=12mm

**Zoom Scan (7x7x7)/Cube 0:** Measurement grid: dx=5mm, dy=5mm, dz=5mm

Reference Value = 6.642 V/m; Power Drift = 0.11 dB

Peak SAR (extrapolated) = 0.152 W/kg

**SAR(1 g) = 0.078 W/kg**

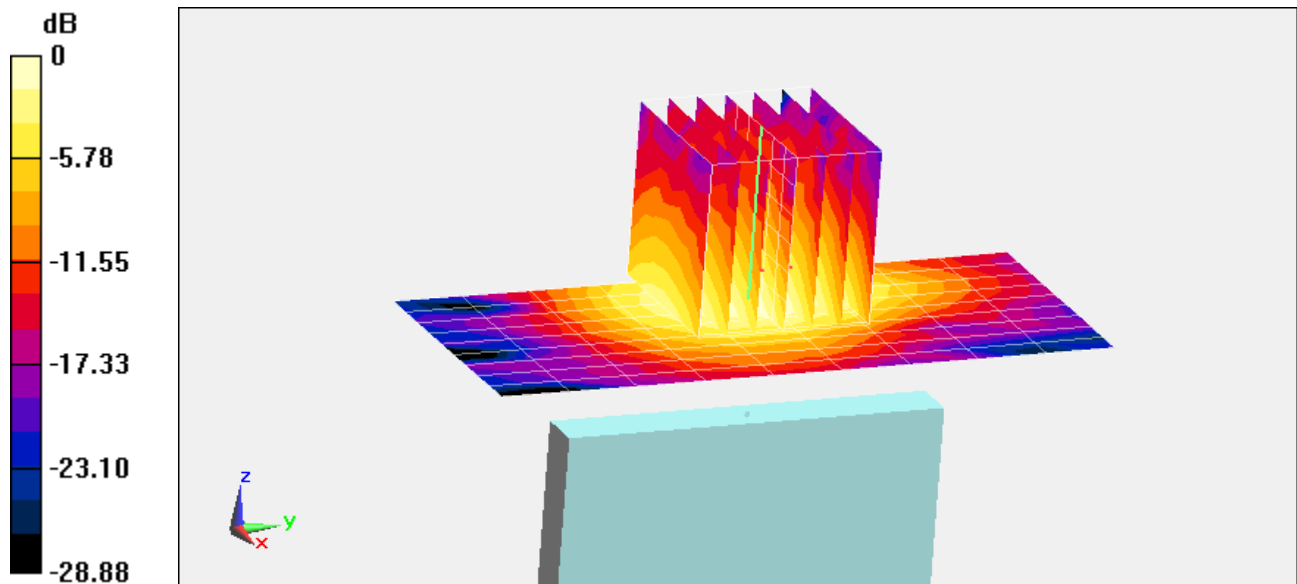

## APPENDIX B: SYSTEM VERIFICATION

# PCTEST ENGINEERING LABORATORY, INC.

**DUT: Dipole 750 MHz; Type: D750V3; Serial: 1003**

Communication System: UID 0, CW; Frequency: 750 MHz; Duty Cycle: 1:1

Medium: 740 Body, Medium parameters used (interpolated):

$f = 750 \text{ MHz}$ ;  $\sigma = 0.985 \text{ S/m}$ ;  $\epsilon_r = 53.238$ ;  $\rho = 1000 \text{ kg/m}^3$

Phantom section: Flat Section; Space: 1.5 cm

Test Date: 02-28-2014; Ambient Temp: 23.6°C; Tissue Temp: 21.8°C

Probe: ES3DV3 - SN3318; ConvF(6.35, 6.35, 6.35); Calibrated: 4/29/2013;

Sensor-Surface: 4mm (Mechanical Surface Detection)

Electronics: DAE4 Sn1364; Calibrated: 4/22/2013

Phantom: ELI left; Type: QDOVA002AA; Serial: TP:1202

Measurement SW: DASY52, Version 52.8 (7); SEMCAD X Version 14.6.10 (7164)

## 750 MHz System Verification

**Area Scan (7x15x1):** Measurement grid: dx=15mm, dy=15mm

**Zoom Scan (5x5x7)/Cube 0:** Measurement grid: dx=8mm, dy=8mm, dz=5mm

Input Power = 20.0 dBm (100 mW)

Peak SAR (extrapolated) = 1.28 W/kg

**SAR(1 g) = 0.897 W/kg**

Deviation = 2.28%

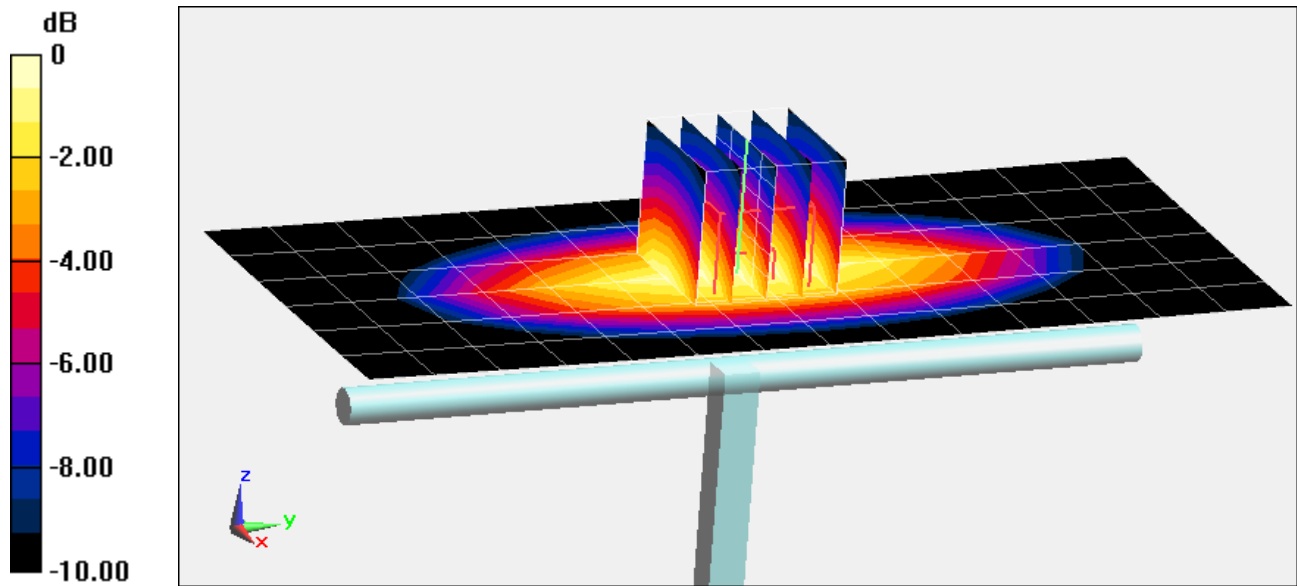

0 dB = 0.963 W/kg = -0.16 dBW/kg

# PCTEST ENGINEERING LABORATORY, INC.

**DUT: Dipole 835 MHz; Type: D835V2; Serial: 4d119**

Communication System: UID 0, CW; Frequency: 835 MHz; Duty Cycle: 1:1

Medium: 835 Body, Medium parameters used:

$f = 835 \text{ MHz}$ ;  $\sigma = 0.999 \text{ S/m}$ ;  $\epsilon_r = 53.32$ ;  $\rho = 1000 \text{ kg/m}^3$

Phantom section: Flat Section; Space: 1.5 cm

Test Date: 02-27-2014; Ambient Temp: 24.4°C; Tissue Temp: 22.9°C

Probe: ES3DV3 - SN3209; ConvF(6.28, 6.28, 6.28); Calibrated: 3/15/2013;

Sensor-Surface: 4mm (Mechanical Surface Detection)

Electronics: DAE4 Sn1334; Calibrated: 3/8/2013

Phantom: ELI v5.0; Type: QDOVA002AA; Serial: TP-1158

Measurement SW: DASY52, Version 52.8 (7); SEMCAD X Version 14.6.10 (7164)

## 835 MHz System Verification

**Area Scan (7x14x1):** Measurement grid: dx=15mm, dy=15mm

**Zoom Scan (5x5x7)/Cube 0:** Measurement grid: dx=8mm, dy=8mm, dz=5mm

Input Power = 20.0 dBm (100 mW)

Peak SAR (extrapolated) = 1.37 W/kg

**SAR(1 g) = 0.941 W/kg**

Deviation = -1.36%

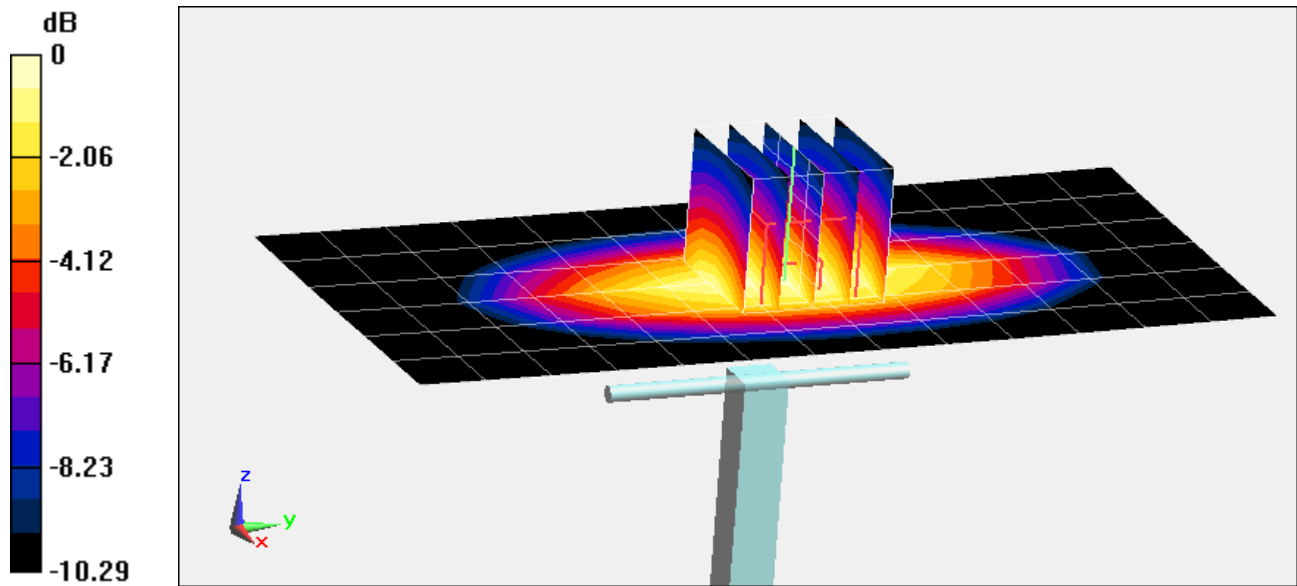

0 dB = 1.02 W/kg = 0.09 dBW/kg

# PCTEST ENGINEERING LABORATORY, INC.

**DUT: Dipole 1750 MHz; Type: D1750V2; Serial: 1051**

Communication System: UID 0, CW; Frequency: 1750 MHz; Duty Cycle: 1:1

Medium: 1750 Body, Medium parameters used:

$f = 1750 \text{ MHz}$ ;  $\sigma = 1.476 \text{ S/m}$ ;  $\epsilon_r = 51.565$ ;  $\rho = 1000 \text{ kg/m}^3$

Phantom section: Flat Section; Space: 1.0 cm

Test Date: 02-24-2014; Ambient Temp: 24.4°C; Tissue Temp: 23.0°C

Probe: ES3DV3 - SN3209; ConvF(5.03, 5.03, 5.03); Calibrated: 3/15/2013;

Sensor-Surface: 4mm (Mechanical Surface Detection)

Electronics: DAE4 Sn1334; Calibrated: 3/8/2013

Phantom: ELI v5.0; Type: QDOVA002AA; Serial: TP-1158

Measurement SW: DASY52, Version 52.8 (7); SEMCAD X Version 14.6.10 (7164)

## 1750 MHz System Verification

**Area Scan (7x9x1):** Measurement grid: dx=15mm, dy=15mm

**Zoom Scan (5x5x7)/Cube 0:** Measurement grid: dx=8mm, dy=8mm, dz=5mm

Input Power = 20.0 dBm (100 mW)

Peak SAR (extrapolated) = 6.29 W/kg

**SAR(1 g) = 3.57 W/kg**

Deviation = -5.56%

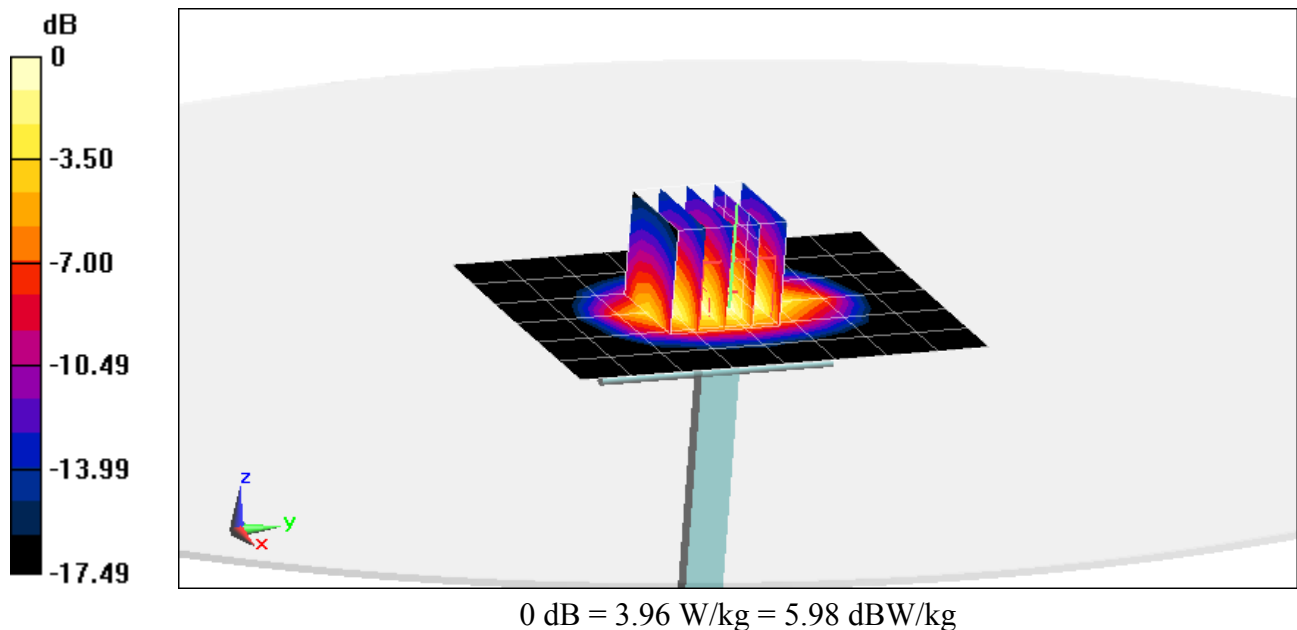

# PCTEST ENGINEERING LABORATORY, INC.

**DUT: Dipole 1900 MHz; Type: D1900V2; Serial: 5d149**

Communication System: UID 0, CW; Frequency: 1900 MHz; Duty Cycle: 1:1

Medium: 1900 Body, Medium parameters used (interpolated):

$f = 1900 \text{ MHz}$ ;  $\sigma = 1.539 \text{ S/m}$ ;  $\epsilon_r = 51.56$ ;  $\rho = 1000 \text{ kg/m}^3$

Phantom section: Flat Section; Space: 1.0 cm

Test Date: 02-24-2014; Ambient Temp: 24.4°C; Tissue Temp: 23.0°C

Probe: ES3DV3 - SN3209; ConvF(4.77, 4.77, 4.77); Calibrated: 3/15/2013;

Sensor-Surface: 4mm (Mechanical Surface Detection)

Electronics: DAE4 Sn1334; Calibrated: 3/8/2013

Phantom: SAM Front; Type: SAM; Serial: 1686

Measurement SW: DASY52, Version 52.8 (7); SEMCAD X Version 14.6.10 (7164)

## 1900 MHz System Verification

**Area Scan (7x10x1):** Measurement grid: dx=15mm, dy=15mm

**Zoom Scan (5x5x7)/Cube 0:** Measurement grid: dx=8mm, dy=8mm, dz=5mm

Input Power = 20.0 dBm (100 mW)

Peak SAR (extrapolated) = 7.10 W/kg

**SAR(1 g) = 3.92 W/kg.**

Deviation = -3.21%

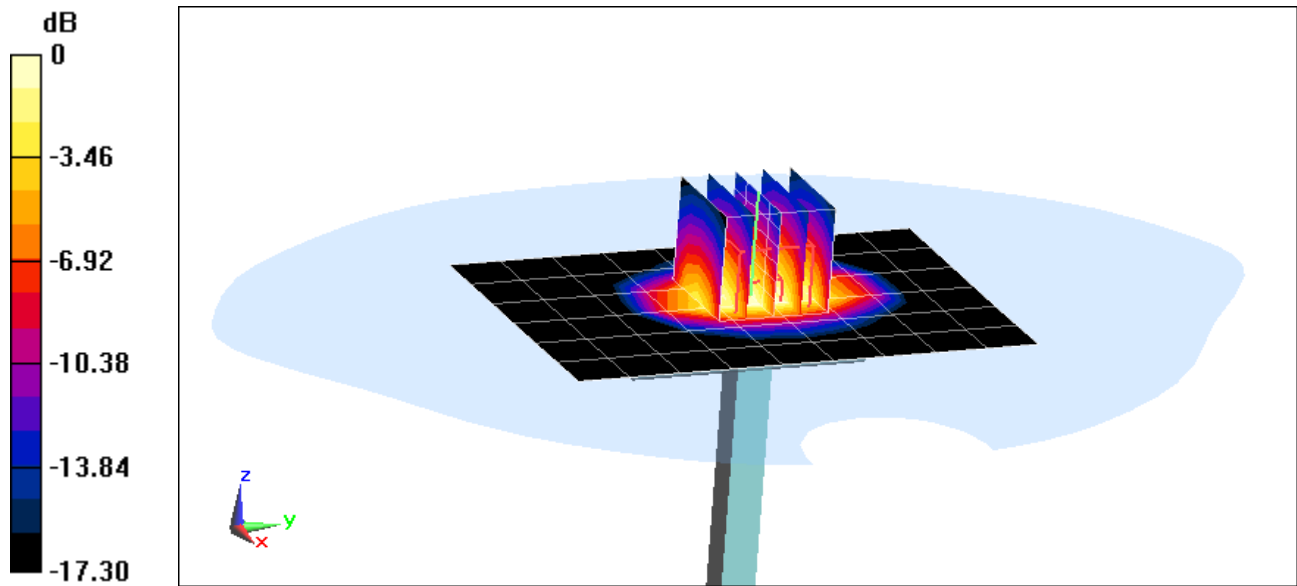

0 dB = 4.41 W/kg = 6.44 dBW/kg

# PCTEST ENGINEERING LABORATORY, INC.

**DUT: Dipole 2450 MHz; Type: D2450V2; Serial: 719**

Communication System: UID 0, CW; Frequency: 2450 MHz; Duty Cycle: 1:1

Medium: 2450 Body Medium parameters used:

$f = 2450 \text{ MHz}$ ;  $\sigma = 2.044 \text{ S/m}$ ;  $\epsilon_r = 51.296$ ;  $\rho = 1000 \text{ kg/m}^3$

Phantom section: Flat Section; Space: 1.0 cm

Test Date: 03-05-2014; Ambient Temp: 24.3°C; Tissue Temp: 23.3°C

Probe: ES3DV3 - SN3258; ConvF(4.14, 4.14, 4.14); Calibrated: 2/25/2014;

Sensor-Surface: 3mm (Mechanical Surface Detection)

Electronics: DAE4 Sn665; Calibrated: 2/26/2014

Phantom: ELI v5.0; Type: QDOVA002AA; Serial: TP-1158

Measurement SW: DASY52, Version 52.8 (7); SEMCAD X Version 14.6.10 (7164)

## 2450 MHz System Verification

**Area Scan (8x9x1):** Measurement grid: dx=12mm, dy=12mm

**Zoom Scan (7x7x7)/Cube 0:** Measurement grid: dx=5mm, dy=5mm, dz=5mm

Input Power= 20.0 dBm (100 mW)

Peak SAR (extrapolated) = 10.9 W/kg

**SAR(1 g) = 5.12 W/kg**

Deviation= -0.97%

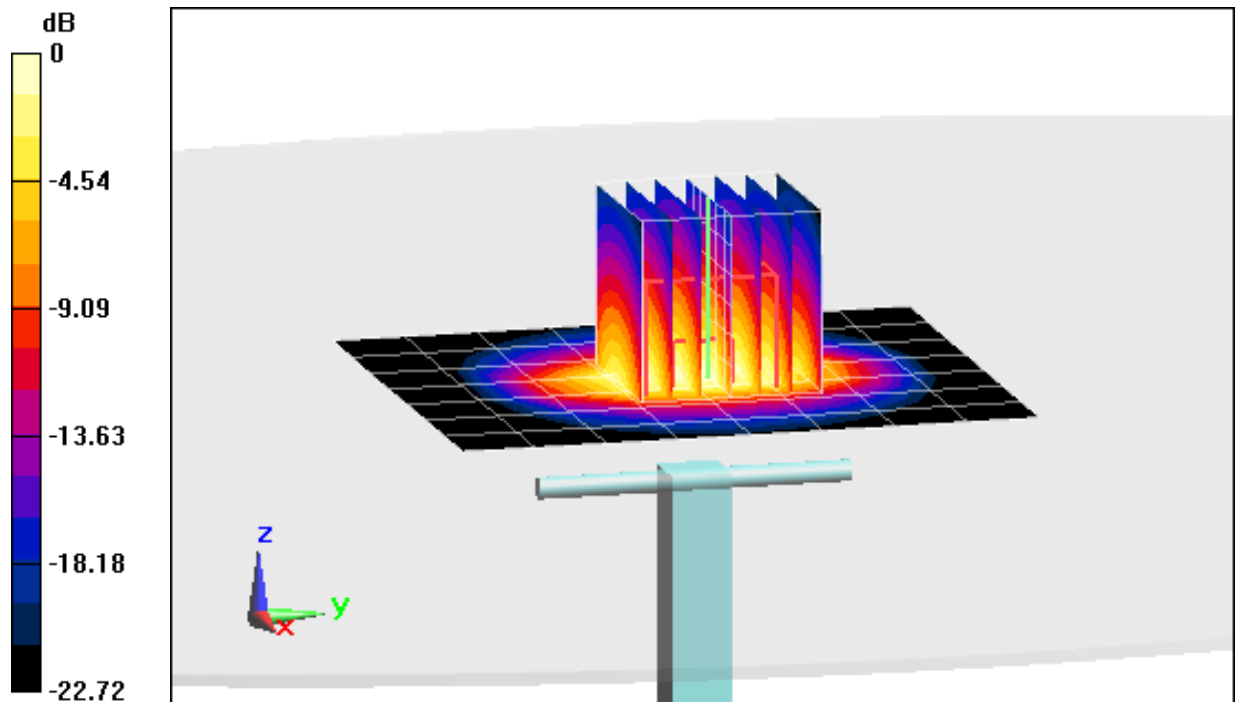

0 dB = 6.64 W/kg = 8.22 dBW/kg

## APPENDIX C: PROBE CALIBRATION



Accredited by the Swiss Accreditation Service (SAS)  
The Swiss Accreditation Service is one of the signatories to the EA  
Multilateral Agreement for the recognition of calibration certificates

Accreditation No.: **SCS 108**

Client **PC Test**

Certificate No: **D750V3-1003\_Jan14**

## CALIBRATION CERTIFICATE

Object **D750V3 - SN: 1003**

Calibration procedure(s) **QA CAL-05.v9  
Calibration procedure for dipole validation kits above 700 MHz**

Calibration date: **January 20, 2014**

*CC  
21/14 ✓*

This calibration certificate documents the traceability to national standards, which realize the physical units of measurements (SI).  
The measurements and the uncertainties with confidence probability are given on the following pages and are part of the certificate.

All calibrations have been conducted in the closed laboratory facility: environment temperature (22 ± 3)°C and humidity < 70%.

Calibration Equipment used (M&TE critical for calibration)

Primary Standards	ID #	Cal Date (Certificate No.)	Scheduled Calibration
Power meter EPM-442A	GB37480704	09-Oct-13 (No. 217-01827)	Oct-14
Power sensor HP 8481A	US37292783	09-Oct-13 (No. 217-01827)	Oct-14
Power sensor HP 8481A	MY41092317	09-Oct-13 (No. 217-01828)	Oct-14
Reference 20 dB Attenuator	SN: 5058 (20k)	04-Apr-13 (No. 217-01736)	Apr-14
Type-N mismatch combination	SN: 5047.3 / 06327	04-Apr-13 (No. 217-01739)	Apr-14
Reference Probe ES3DV3	SN: 3205	30-Dec-13 (No. ES3-3205_Dec13)	Dec-14
DAE4	SN: 601	25-Apr-13 (No. DAE4-601_Apr13)	Apr-14
Secondary Standards	ID #	Check Date (in house)	Scheduled Check
RF generator R&S SMT-06	100005	04-Aug-99 (in house check Oct-13)	In house check: Oct-16
Network Analyzer HP 8753E	US37390585 S4206	18-Oct-01 (in house check Oct-13)	In house check: Oct-14

Calibrated by: **Israe El-Naouq** Laboratory Technician  
Approved by: **Katja Pokovic** Technical Manager

Signature  
*Israe El-Naouq*  
*Katja Pokovic*

Issued: January 21, 2014

This calibration certificate shall not be reproduced except in full without written approval of the laboratory.



Accredited by the Swiss Accreditation Service (SAS)

Accreditation No.: **SCS 108**

The Swiss Accreditation Service is one of the signatories to the EA  
Multilateral Agreement for the recognition of calibration certificates

### Glossary:

TSL	tissue simulating liquid
ConvF	sensitivity in TSL / NORM x,y,z
N/A	not applicable or not measured

### Calibration is Performed According to the Following Standards:

- IEEE Std 1528-2013, "IEEE Recommended Practice for Determining the Peak Spatial-Averaged Specific Absorption Rate (SAR) in the Human Head from Wireless Communications Devices: Measurement Techniques", June 2013
- IEC 62209-1, "Procedure to measure the Specific Absorption Rate (SAR) for hand-held devices used in close proximity to the ear (frequency range of 300 MHz to 3 GHz)", February 2005
- KDB 865664, "SAR Measurement Requirements for 100 MHz to 6 GHz"

### Additional Documentation:

- DASY4/5 System Handbook

### Methods Applied and Interpretation of Parameters:

- Measurement Conditions:** Further details are available from the Validation Report at the end of the certificate. All figures stated in the certificate are valid at the frequency indicated.
- Antenna Parameters with TSL:** The dipole is mounted with the spacer to position its feed point exactly below the center marking of the flat phantom section, with the arms oriented parallel to the body axis.
- Feed Point Impedance and Return Loss:** These parameters are measured with the dipole positioned under the liquid filled phantom. The impedance stated is transformed from the measurement at the SMA connector to the feed point. The Return Loss ensures low reflected power. No uncertainty required.
- Electrical Delay:** One-way delay between the SMA connector and the antenna feed point. No uncertainty required.
- SAR measured:** SAR measured at the stated antenna input power.
- SAR normalized:** SAR as measured, normalized to an input power of 1 W at the antenna connector.
- SAR for nominal TSL parameters:** The measured TSL parameters are used to calculate the nominal SAR result.

The reported uncertainty of measurement is stated as the standard uncertainty of measurement multiplied by the coverage factor  $k=2$ , which for a normal distribution corresponds to a coverage probability of approximately 95%.

## Measurement Conditions

DASY system configuration, as far as not given on page 1.

<b>DASY Version</b>	DASY5	V52.8.7
<b>Extrapolation</b>	Advanced Extrapolation	
<b>Phantom</b>	Modular Flat Phantom	
<b>Distance Dipole Center - TSL</b>	15 mm	with Spacer
<b>Zoom Scan Resolution</b>	dx, dy, dz = 5 mm	
<b>Frequency</b>	750 MHz $\pm$ 1 MHz	

## Head TSL parameters

The following parameters and calculations were applied.

	Temperature	Permittivity	Conductivity
<b>Nominal Head TSL parameters</b>	22.0 °C	41.9	0.89 mho/m
<b>Measured Head TSL parameters</b>	(22.0 $\pm$ 0.2) °C	40.8 $\pm$ 6 %	0.92 mho/m $\pm$ 6 %
<b>Head TSL temperature change during test</b>	< 0.5 °C	----	----

## SAR result with Head TSL

<b>SAR averaged over 1 cm<sup>3</sup> (1 g) of Head TSL</b>	Condition	
SAR measured	250 mW input power	2.16 W/kg
SAR for nominal Head TSL parameters	normalized to 1W	<b>8.37 W/kg <math>\pm</math> 17.0 % (k=2)</b>

<b>SAR averaged over 10 cm<sup>3</sup> (10 g) of Head TSL</b>	condition	
SAR measured	250 mW input power	1.40 W/kg
SAR for nominal Head TSL parameters	normalized to 1W	<b>5.46 W/kg <math>\pm</math> 16.5 % (k=2)</b>

## Body TSL parameters

The following parameters and calculations were applied.

	Temperature	Permittivity	Conductivity
<b>Nominal Body TSL parameters</b>	22.0 °C	55.5	0.96 mho/m
<b>Measured Body TSL parameters</b>	(22.0 $\pm$ 0.2) °C	54.0 $\pm$ 6 %	0.98 mho/m $\pm$ 6 %
<b>Body TSL temperature change during test</b>	< 0.5 °C	----	----

## SAR result with Body TSL

<b>SAR averaged over 1 cm<sup>3</sup> (1 g) of Body TSL</b>	Condition	
SAR measured	250 mW input power	2.24 W/kg
SAR for nominal Body TSL parameters	normalized to 1W	<b>8.77 W/kg <math>\pm</math> 17.0 % (k=2)</b>

<b>SAR averaged over 10 cm<sup>3</sup> (10 g) of Body TSL</b>	condition	
SAR measured	250 mW input power	1.47 W/kg
SAR for nominal Body TSL parameters	normalized to 1W	<b>5.78 W/kg <math>\pm</math> 16.5 % (k=2)</b>

## Appendix

### Antenna Parameters with Head TSL

Impedance, transformed to feed point	54.7 $\Omega$ - 0.2 j $\Omega$
Return Loss	- 27.0 dB

### Antenna Parameters with Body TSL

Impedance, transformed to feed point	49.5 $\Omega$ - 2.6 j $\Omega$
Return Loss	- 31.4 dB

### General Antenna Parameters and Design

Electrical Delay (one direction)	1.043 ns
----------------------------------	----------

After long term use with 100W radiated power, only a slight warming of the dipole near the feedpoint can be measured.

The dipole is made of standard semirigid coaxial cable. The center conductor of the feeding line is directly connected to the second arm of the dipole. The antenna is therefore short-circuited for DC-signals. On some of the dipoles, small end caps are added to the dipole arms in order to improve matching when loaded according to the position as explained in the "Measurement Conditions" paragraph. The SAR data are not affected by this change. The overall dipole length is still according to the Standard.

No excessive force must be applied to the dipole arms, because they might bend or the soldered connections near the feedpoint may be damaged.

### Additional EUT Data

Manufactured by	SPEAG
Manufactured on	January 21, 2009

# DASY5 Validation Report for Head TSL

Date: 20.01.2014

Test Laboratory: SPEAG, Zurich, Switzerland

**DUT: Dipole 750 MHz; Type: D750V3; Serial: D750V3 - SN: 1003**

Communication System: UID 0 - CW; Frequency: 750 MHz

Medium parameters used:  $f = 750$  MHz;  $\sigma = 0.92$  S/m;  $\epsilon_r = 40.8$ ;  $\rho = 1000$  kg/m<sup>3</sup>

Phantom section: Flat Section

Measurement Standard: DASY5 (IEEE/IEC/ANSI C63.19-2007)

DASY52 Configuration:

- Probe: ES3DV3 - SN3205; ConvF(6.37, 6.37, 6.37); Calibrated: 30.12.2013;
- Sensor-Surface: 3mm (Mechanical Surface Detection)
- Electronics: DAE4 Sn601; Calibrated: 25.04.2013
- Phantom: Flat Phantom 4.9L; Type: QD000P49AA; Serial: 1001
- DASY52 52.8.7(1137); SEMCAD X 14.6.10(7164)

## Dipole Calibration for Head Tissue/Pin=250 mW, d=15mm/Zoom Scan (7x7x7)/Cube 0:

Measurement grid: dx=5mm, dy=5mm, dz=5mm

Reference Value = 53.711 V/m; Power Drift = 0.02 dB

Peak SAR (extrapolated) = 3.27 W/kg

**SAR(1 g) = 2.16 W/kg; SAR(10 g) = 1.4 W/kg**

Maximum value of SAR (measured) = 2.51 W/kg

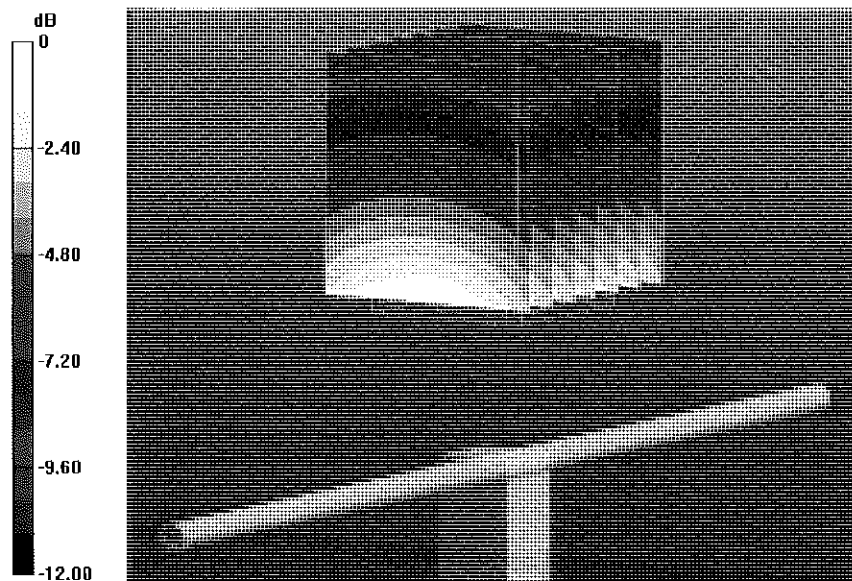

0 dB = 2.51 W/kg = 4.00 dBW/kg

# Impedance Measurement Plot for Head TSL

20 Jan 2014 16:36:06

CH1 S11 1 U FS

1: 54.678  $\Omega$  -156.25 m $\angle$  1.3581 nF

750.000 000 MHz

\*  
De1

C $\Delta$

Avg  
16

H1d

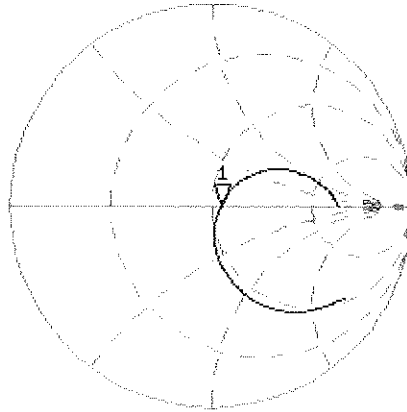

CH2 S11 LOG

5 dB/REF -20 dB

1: -26.992 dB

750.000 000 MHz

C $\Delta$

Avg  
16

H1d

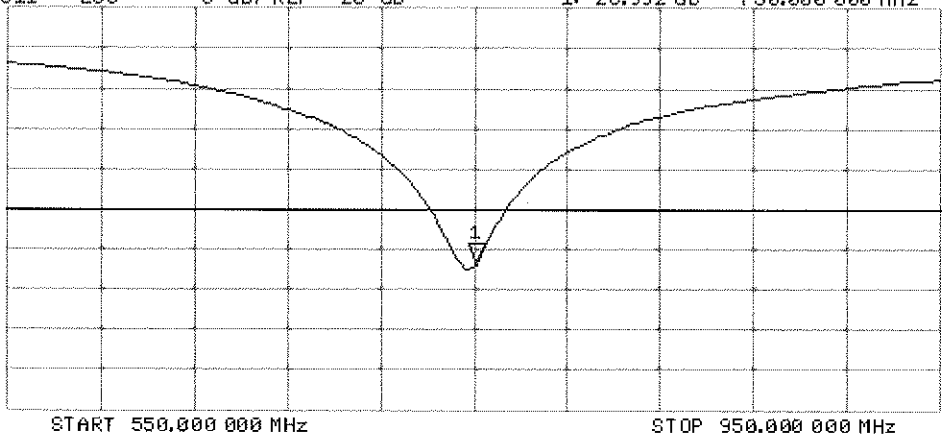

## DASY5 Validation Report for Body TSL

Date: 20.01.2014

Test Laboratory: SPEAG, Zurich, Switzerland

**DUT: Dipole 750 MHz; Type: D750V3; Serial: D750V3 - SN: 1003**

Communication System: UID 0 - CW; Frequency: 750 MHz

Medium parameters used:  $f = 750$  MHz;  $\sigma = 0.98$  S/m;  $\epsilon_r = 54$ ;  $\rho = 1000$  kg/m<sup>3</sup>

Phantom section: Flat Section

Measurement Standard: DASY5 (IEEE/IEC/ANSI C63.19-2007)

DASY52 Configuration:

- Probe: ES3DV3 - SN3205; ConvF(6.13, 6.13, 6.13); Calibrated: 30.12.2013;
- Sensor-Surface: 3mm (Mechanical Surface Detection)
- Electronics: DAE4 Sn601; Calibrated: 25.04.2013
- Phantom: Flat Phantom 4.9L; Type: QD000P49AA; Serial: 1001
- DASY52 52.8.7(1137); SEMCAD X 14.6.10(7164)

### Dipole Calibration for Body Tissue/Pin=250 mW, d=15mm/Zoom Scan (7x7x7)/Cube 0:

Measurement grid: dx=5mm, dy=5mm, dz=5mm

Reference Value = 53.082 V/m; Power Drift = 0.03 dB

Peak SAR (extrapolated) = 3.31 W/kg

**SAR(1 g) = 2.24 W/kg; SAR(10 g) = 1.47 W/kg**

Maximum value of SAR (measured) = 2.58 W/kg

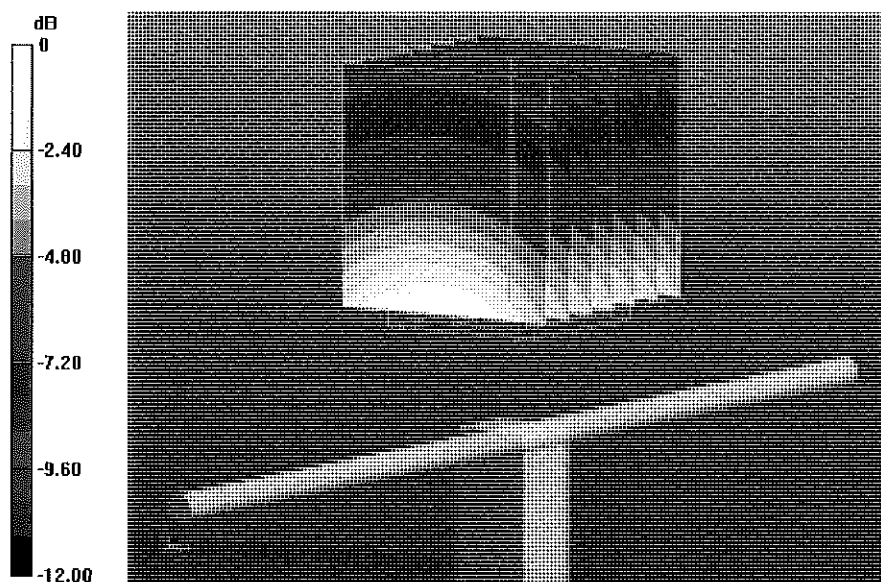

0 dB = 2.58 W/kg = 4.12 dBW/kg

# Impedance Measurement Plot for Body TSL

20 Jan 2014 10:20:18

CH1 S11 1 U FS 1: 49.459  $\Omega$  -2.6367  $\Omega$  80.481 pF 750.000 000 MHz

\*  
De1

CA

Avg  
16

H1d

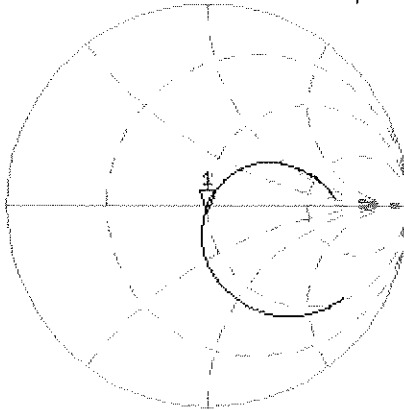

CH2 S11 LOG 5 dB/REF -20 dB 1: -31.359 dB 750.000 000 MHz

CA

Avg  
16

H1d

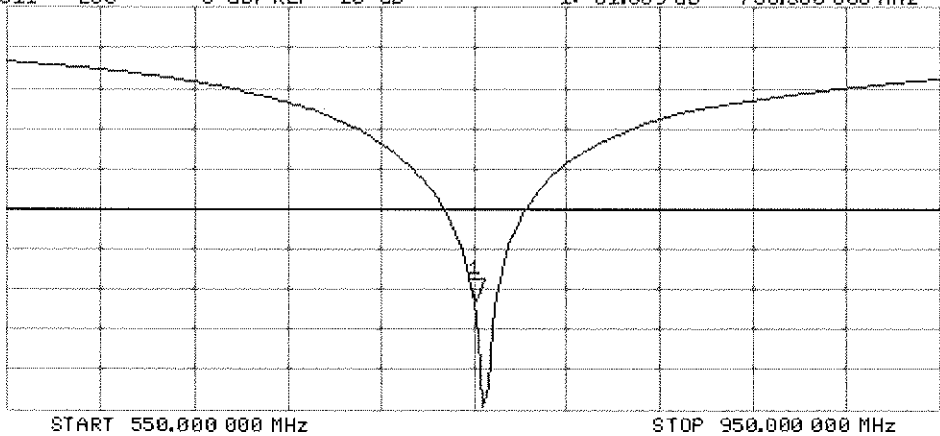



Accredited by the Swiss Accreditation Service (SAS)  
The Swiss Accreditation Service is one of the signatories to the EA  
Multilateral Agreement for the recognition of calibration certificates

Accreditation No.: **SCS 108**

Client **PC Test**

Certificate No: **D835V2-4d119\_Apr13**

## CALIBRATION CERTIFICATE

Object **D835V2 - SN: 4d119**

Calibration procedure(s) **QA CAL-05.v9  
Calibration procedure for dipole validation kits above 700 MHz**

Calibration date: **April 25, 2013**

✓  
KOK  
5/8/13

This calibration certificate documents the traceability to national standards, which realize the physical units of measurements (SI).  
The measurements and the uncertainties with confidence probability are given on the following pages and are part of the certificate.

All calibrations have been conducted in the closed laboratory facility: environment temperature ( $22 \pm 3$ )°C and humidity < 70%.

Calibration Equipment used (M&TE critical for calibration)

Primary Standards	ID #	Cal Date (Certificate No.)	Scheduled Calibration
Power meter EPM-442A	GB37480704	01-Nov-12 (No. 217-01640)	Oct-13
Power sensor HP 8481A	US37292783	01-Nov-12 (No. 217-01640)	Oct-13
Reference 20 dB Attenuator	SN: 5058 (20k)	04-Apr-13 (No. 217-01736)	Apr-14
Type-N mismatch combination	SN: 5047.3 / 06327	04-Apr-13 (No. 217-01739)	Apr-14
Reference Probe ES3DV3	SN: 3205	28-Dec-12 (No. ES3-3205_Dec12)	Dec-13
DAE4	SN: 909	11-Sep-12 (No. DAE4-909_Sep12)	Sep-13
Secondary Standards	ID #	Check Date (in house)	Scheduled Check
Power sensor HP 8481A	MY41092317	18-Oct-02 (in house check Oct-11)	In house check: Oct-13
RF generator R&S SMT-06	100005	04-Aug-99 (in house check Oct-11)	In house check: Oct-13
Network Analyzer HP 8753E	US37390585 S4206	18-Oct-01 (in house check Oct-12)	In house check: Oct-13

Calibrated by: **Claudio Leubler**      Name: **Claudio Leubler**      Function: **Laboratory Technician**

Approved by: **Katja Pokovic**      Name: **Katja Pokovic**      Technical Manager

Signature

Issued: April 26, 2013

This calibration certificate shall not be reproduced except in full without written approval of the laboratory.



Accredited by the Swiss Accreditation Service (SAS)  
The Swiss Accreditation Service is one of the signatories to the EA  
Multilateral Agreement for the recognition of calibration certificates

Accreditation No.: **SCS 108**

### Glossary:

TSL	tissue simulating liquid
ConvF	sensitivity in TSL / NORM x,y,z
N/A	not applicable or not measured

### Calibration is Performed According to the Following Standards:

- IEEE Std 1528-2003, "IEEE Recommended Practice for Determining the Peak Spatial-Averaged Specific Absorption Rate (SAR) in the Human Head from Wireless Communications Devices: Measurement Techniques", December 2003
- IEC 62209-1, "Procedure to measure the Specific Absorption Rate (SAR) for hand-held devices used in close proximity to the ear (frequency range of 300 MHz to 3 GHz)", February 2005
- Federal Communications Commission Office of Engineering & Technology (FCC OET), "Evaluating Compliance with FCC Guidelines for Human Exposure to Radiofrequency Electromagnetic Fields; Additional Information for Evaluating Compliance of Mobile and Portable Devices with FCC Limits for Human Exposure to Radiofrequency Emissions", Supplement C (Edition 01-01) to Bulletin 65

### Additional Documentation:

- DASY4/5 System Handbook

### Methods Applied and Interpretation of Parameters:

- Measurement Conditions:* Further details are available from the Validation Report at the end of the certificate. All figures stated in the certificate are valid at the frequency indicated.
- Antenna Parameters with TSL:* The dipole is mounted with the spacer to position its feed point exactly below the center marking of the flat phantom section, with the arms oriented parallel to the body axis.
- Feed Point Impedance and Return Loss:* These parameters are measured with the dipole positioned under the liquid filled phantom. The impedance stated is transformed from the measurement at the SMA connector to the feed point. The Return Loss ensures low reflected power. No uncertainty required.
- Electrical Delay:* One-way delay between the SMA connector and the antenna feed point. No uncertainty required.
- SAR measured:* SAR measured at the stated antenna input power.
- SAR normalized:* SAR as measured, normalized to an input power of 1 W at the antenna connector.
- SAR for nominal TSL parameters:* The measured TSL parameters are used to calculate the nominal SAR result.

The reported uncertainty of measurement is stated as the standard uncertainty of measurement multiplied by the coverage factor  $k=2$ , which for a normal distribution corresponds to a coverage probability of approximately 95%.

## Measurement Conditions

DASY system configuration, as far as not given on page 1.

DASY Version	DASY5	V52.8.6
Extrapolation	Advanced Extrapolation	
Phantom	Modular Flat Phantom	
Distance Dipole Center - TSL	15 mm	with Spacer
Zoom Scan Resolution	dx, dy, dz = 5 mm	
Frequency	835 MHz $\pm$ 1 MHz	

## Head TSL parameters

The following parameters and calculations were applied.

	Temperature	Permittivity	Conductivity
Nominal Head TSL parameters	22.0 °C	41.5	0.90 mho/m
Measured Head TSL parameters	(22.0 $\pm$ 0.2) °C	40.8 $\pm$ 6 %	0.94 mho/m $\pm$ 6 %
Head TSL temperature change during test	< 0.5 °C	----	----

## SAR result with Head TSL

SAR averaged over 1 cm <sup>3</sup> (1 g) of Head TSL	Condition	
SAR measured	250 mW input power	2.51 W/kg
SAR for nominal Head TSL parameters	normalized to 1W	<b>9.68 W/kg <math>\pm</math> 17.0 % (k=2)</b>

SAR averaged over 10 cm <sup>3</sup> (10 g) of Head TSL	condition	
SAR measured	250 mW input power	1.62 W/kg
SAR for nominal Head TSL parameters	normalized to 1W	<b>6.30 W/kg <math>\pm</math> 16.5 % (k=2)</b>

## Body TSL parameters

The following parameters and calculations were applied.

	Temperature	Permittivity	Conductivity
Nominal Body TSL parameters	22.0 °C	55.2	0.97 mho/m
Measured Body TSL parameters	(22.0 $\pm$ 0.2) °C	54.0 $\pm$ 6 %	1.01 mho/m $\pm$ 6 %
Body TSL temperature change during test	< 0.5 °C	----	----

## SAR result with Body TSL

SAR averaged over 1 cm <sup>3</sup> (1 g) of Body TSL	Condition	
SAR measured	250 mW input power	2.47 W/kg
SAR for nominal Body TSL parameters	normalized to 1W	<b>9.54 W/kg <math>\pm</math> 17.0 % (k=2)</b>

SAR averaged over 10 cm <sup>3</sup> (10 g) of Body TSL	condition	
SAR measured	250 mW input power	1.62 W/kg
SAR for nominal Body TSL parameters	normalized to 1W	<b>6.31 W/kg <math>\pm</math> 16.5 % (k=2)</b>

## Appendix

### Antenna Parameters with Head TSL

Impedance, transformed to feed point	50.1 $\Omega$ - 4.7 j $\Omega$
Return Loss	- 26.6 dB

### Antenna Parameters with Body TSL

Impedance, transformed to feed point	45.8 $\Omega$ - 6.3 j $\Omega$
Return Loss	- 22.1 dB

### General Antenna Parameters and Design

Electrical Delay (one direction)	1.385 ns
----------------------------------	----------

After long term use with 100W radiated power, only a slight warming of the dipole near the feedpoint can be measured.

The dipole is made of standard semirigid coaxial cable. The center conductor of the feeding line is directly connected to the second arm of the dipole. The antenna is therefore short-circuited for DC-signals. On some of the dipoles, small end caps are added to the dipole arms in order to improve matching when loaded according to the position as explained in the "Measurement Conditions" paragraph. The SAR data are not affected by this change. The overall dipole length is still according to the Standard.

No excessive force must be applied to the dipole arms, because they might bend or the soldered connections near the feedpoint may be damaged.

### Additional EUT Data

Manufactured by	SPEAG
Manufactured on	June 29, 2010

## DASY5 Validation Report for Head TSL

Date: 25.04.2013

Test Laboratory: SPEAG, Zurich, Switzerland

**DUT: Dipole 835 MHz; Type: D835V2; Serial: D835V2 - SN: 4d119**

Communication System: UID 0 - CW; Frequency: 835 MHz

Medium parameters used:  $f = 835$  MHz;  $\sigma = 0.94$  S/m;  $\epsilon_r = 40.8$ ;  $\rho = 1000$  kg/m<sup>3</sup>

Phantom section: Flat Section

Measurement Standard: DASY5 (IEEE/IEC/ANSI C63.19-2007)

DASY52 Configuration:

- Probe: ES3DV3 - SN3205; ConvF(6.05, 6.05, 6.05); Calibrated: 28.12.2012;
- Sensor-Surface: 3mm (Mechanical Surface Detection)
- Electronics: DAE4 Sn909; Calibrated: 11.09.2012
- Phantom: Flat Phantom 4.9L; Type: QD000P49AA; Serial: 1001
- DASY52 52.8.6(1115); SEMCAD X 14.6.9(7117)

### **Dipole Calibration for Head Tissue/Pin=250 mW, d=15mm/Zoom Scan (7x7x7)/Cube 0:**

Measurement grid: dx=5mm, dy=5mm, dz=5mm

Reference Value = 57.387 V/m; Power Drift = 0.03 dB

Peak SAR (extrapolated) = 3.86 W/kg

**SAR(1 g) = 2.51 W/kg; SAR(10 g) = 1.62 W/kg**

Maximum value of SAR (measured) = 2.93 W/kg

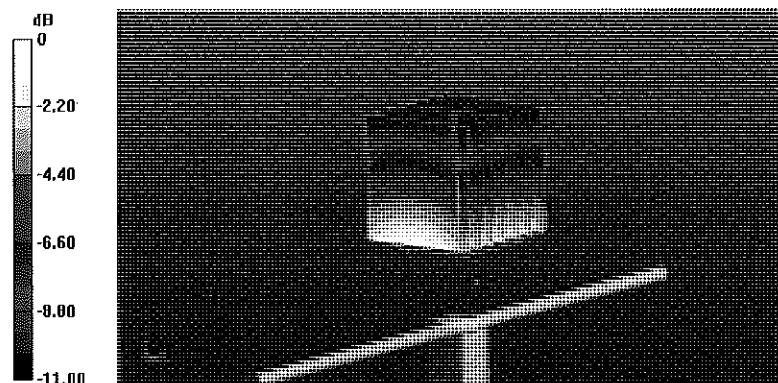

0 dB = 2.93 W/kg = 4.67 dBW/kg

# Impedance Measurement Plot for Head TSL

25 Apr 2013 09:11:06

CH1 S11 1 U FS

1: 50.061  $\Omega$  -4.6621  $\Omega$  40.884 pF

835.000 000 MHz

\*  
Del

CA

Avg  
16

H1 d

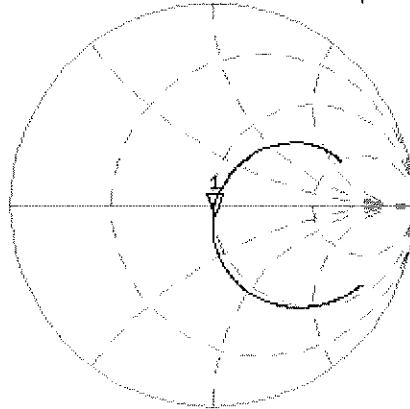

CH2 S11 LOG

5 dB/REF -20 dB

1: -26.641 dB 835.000 000 MHz

CA

Avg  
16

H1 d

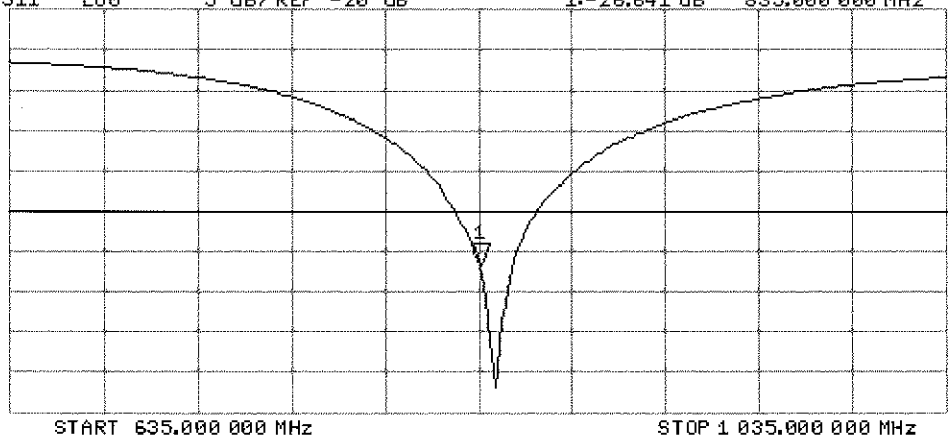

## DASY5 Validation Report for Body TSL

Date: 24.04.2013

Test Laboratory: SPEAG, Zurich, Switzerland

**DUT: Dipole 835 MHz; Type: D835V2; Serial: D835V2 - SN: 4d119**

Communication System: UID 0 - CW; Frequency: 835 MHz

Medium parameters used:  $f = 835$  MHz;  $\sigma = 1.01$  S/m;  $\epsilon_r = 54$ ;  $\rho = 1000$  kg/m<sup>3</sup>

Phantom section: Flat Section

Measurement Standard: DASY5 (IEEE/IEC/ANSI C63.19-2007)

DASY52 Configuration:

- Probe: ES3DV3 - SN3205; ConvF(6.04, 6.04, 6.04); Calibrated: 28.12.2012;
- Sensor-Surface: 3mm (Mechanical Surface Detection)
- Electronics: DAE4 Sn909; Calibrated: 11.09.2012
- Phantom: Flat Phantom 4.9L; Type: QD000P49AA; Serial: 1001
- DASY52 52.8.6(1115); SEMCAD X 14.6.9(7117)

### **Dipole Calibration for Body Tissue/Pin=250 mW, d=15mm/Zoom Scan (7x7x7)/Cube 0:**

Measurement grid: dx=5mm, dy=5mm, dz=5mm

Reference Value = 55.178 V/m; Power Drift = 0.03 dB

Peak SAR (extrapolated) = 3.68 W/kg

**SAR(1 g) = 2.47 W/kg; SAR(10 g) = 1.62 W/kg**

Maximum value of SAR (measured) = 2.89 W/kg

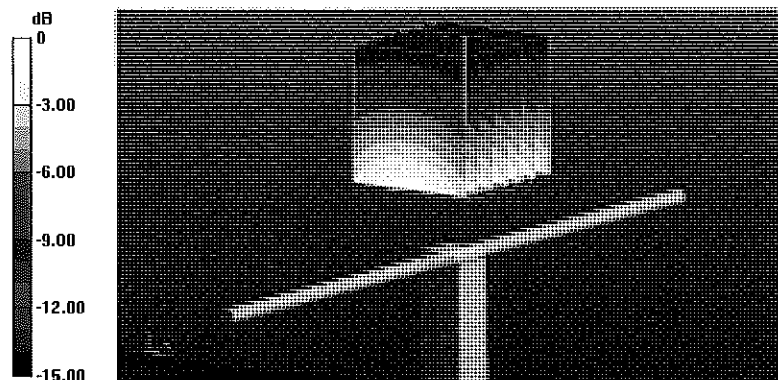

0 dB = 2.89 W/kg = 4.61 dBW/kg

# Impedance Measurement Plot for Body TSL

24 Apr 2013 11:33:44

CH1 S11 1 U FS

2: 45.773  $\Omega$  -6.2773  $\Delta$  30.364 pF

835.000 000 MHz

\*  
DeI

CΔ

Avg  
16

H1d

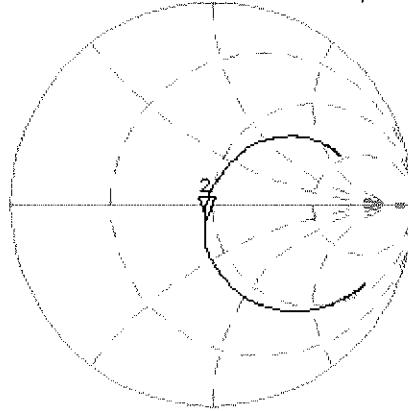

CH2 S11 LOG

5 dB/REF -20 dB

2: -22.065 dB

835.000 000 MHz

CΔ

Avg  
16

H1d

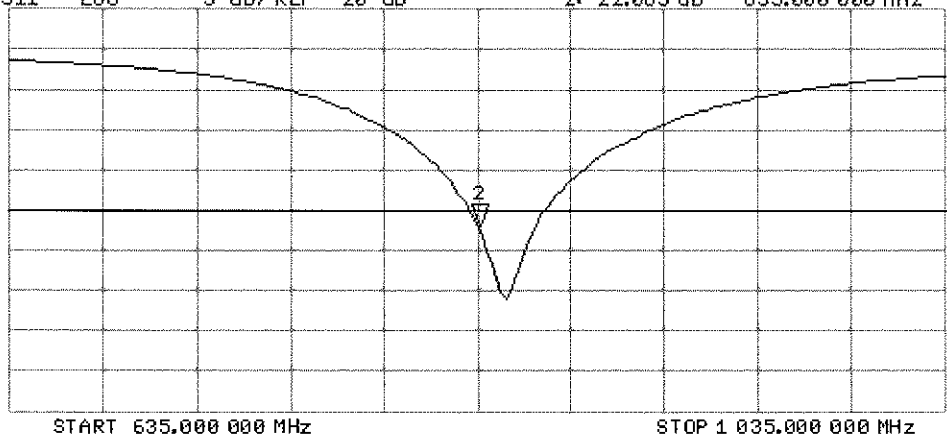



Accredited by the Swiss Accreditation Service (SAS)  
The Swiss Accreditation Service is one of the signatories to the EA  
Multilateral Agreement for the recognition of calibration certificates

Accreditation No.: **SCS 108**

Client **PC Test**

Certificate No: **D1750V2-1051\_Apr13**

## CALIBRATION CERTIFICATE

Object **D1750V2 - SN: 1051**

Calibration procedure(s) **QA CAL-05.v9  
Calibration procedure for dipole validation kits above 700 MHz**

Calibration date: **April 30, 2013**

✓  
LOK  
5/8/13

This calibration certificate documents the traceability to national standards, which realize the physical units of measurements (SI).  
The measurements and the uncertainties with confidence probability are given on the following pages and are part of the certificate.

All calibrations have been conducted in the closed laboratory facility: environment temperature ( $22 \pm 3$ )°C and humidity < 70%.

Calibration Equipment used (M&TE critical for calibration)

Primary Standards	ID #	Cal Date (Certificate No.)	Scheduled Calibration
Power meter EPM-442A	GB37480704	01-Nov-12 (No. 217-01640)	Oct-13
Power sensor HP 8481A	US37292783	01-Nov-12 (No. 217-01640)	Oct-13
Reference 20 dB Attenuator	SN: 5058 (20k)	04-Apr-13 (No. 217-01736)	Apr-14
Type-N mismatch combination	SN: 5047.3 / 06327	04-Apr-13 (No. 217-01739)	Apr-14
Reference Probe ES3DV3	SN: 3205	28-Dec-12 (No. ES3-3205_Dec12)	Dec-13
DAE4	SN: 601	25-Apr-13 (No. DAE4-601_Apr13)	Apr-14
Secondary Standards	ID #	Check Date (in house)	Scheduled Check
Power sensor HP 8481A	MY41092317	18-Oct-02 (in house check Oct-11)	In house check: Oct-13
RF generator R&S SMT-06	100005	04-Aug-99 (in house check Oct-11)	In house check: Oct-13
Network Analyzer HP 8753E	US37390585 S4206	18-Oct-01 (in house check Oct-12)	In house check: Oct-13

Calibrated by: **Claudio Leubler**      Name: Claudio Leubler      Function: Laboratory Technician

Signature

Approved by: **Katja Pokovic**      Name: Katja Pokovic      Technical Manager

Issued: April 30, 2013

This calibration certificate shall not be reproduced except in full without written approval of the laboratory.



Accredited by the Swiss Accreditation Service (SAS)

The Swiss Accreditation Service is one of the signatories to the EA Multilateral Agreement for the recognition of calibration certificates

Accreditation No.: **SCS 108**

### Glossary:

TSL	tissue simulating liquid
ConvF	sensitivity in TSL / NORM x,y,z
N/A	not applicable or not measured

### Calibration is Performed According to the Following Standards:

- IEEE Std 1528-2003, "IEEE Recommended Practice for Determining the Peak Spatial-Averaged Specific Absorption Rate (SAR) in the Human Head from Wireless Communications Devices: Measurement Techniques", December 2003
- IEC 62209-1, "Procedure to measure the Specific Absorption Rate (SAR) for hand-held devices used in close proximity to the ear (frequency range of 300 MHz to 3 GHz)", February 2005
- Federal Communications Commission Office of Engineering & Technology (FCC OET), "Evaluating Compliance with FCC Guidelines for Human Exposure to Radiofrequency Electromagnetic Fields; Additional Information for Evaluating Compliance of Mobile and Portable Devices with FCC Limits for Human Exposure to Radiofrequency Emissions", Supplement C (Edition 01-01) to Bulletin 65

### Additional Documentation:

- DASY4/5 System Handbook

### Methods Applied and Interpretation of Parameters:

- Measurement Conditions:* Further details are available from the Validation Report at the end of the certificate. All figures stated in the certificate are valid at the frequency indicated.
- Antenna Parameters with TSL:* The dipole is mounted with the spacer to position its feed point exactly below the center marking of the flat phantom section, with the arms oriented parallel to the body axis.
- Feed Point Impedance and Return Loss:* These parameters are measured with the dipole positioned under the liquid filled phantom. The impedance stated is transformed from the measurement at the SMA connector to the feed point. The Return Loss ensures low reflected power. No uncertainty required.
- Electrical Delay:* One-way delay between the SMA connector and the antenna feed point. No uncertainty required.
- SAR measured:* SAR measured at the stated antenna input power.
- SAR normalized:* SAR as measured, normalized to an input power of 1 W at the antenna connector.
- SAR for nominal TSL parameters:* The measured TSL parameters are used to calculate the nominal SAR result.

The reported uncertainty of measurement is stated as the standard uncertainty of measurement multiplied by the coverage factor  $k=2$ , which for a normal distribution corresponds to a coverage probability of approximately 95%.

## Measurement Conditions

DASY system configuration, as far as not given on page 1.

<b>DASY Version</b>	DASY5	V52.8.6
<b>Extrapolation</b>	Advanced Extrapolation	
<b>Phantom</b>	Modular Flat Phantom	
<b>Distance Dipole Center - TSL</b>	10 mm	with Spacer
<b>Zoom Scan Resolution</b>	dx, dy, dz = 5 mm	
<b>Frequency</b>	1750 MHz $\pm$ 1 MHz	

## Head TSL parameters

The following parameters and calculations were applied.

	Temperature	Permittivity	Conductivity
<b>Nominal Head TSL parameters</b>	22.0 °C	40.1	1.37 mho/m
<b>Measured Head TSL parameters</b>	(22.0 $\pm$ 0.2) °C	39.1 $\pm$ 6 %	1.33 mho/m $\pm$ 6 %
<b>Head TSL temperature change during test</b>	< 0.5 °C	----	----

## SAR result with Head TSL

<b>SAR averaged over 1 cm<sup>3</sup> (1 g) of Head TSL</b>	Condition	
SAR measured	250 mW input power	9.01 W/kg
SAR for nominal Head TSL parameters	normalized to 1W	<b>36.5 W/kg <math>\pm</math> 17.0 % (k=2)</b>

<b>SAR averaged over 10 cm<sup>3</sup> (10 g) of Head TSL</b>	condition	
SAR measured	250 mW input power	4.83 W/kg
SAR for nominal Head TSL parameters	normalized to 1W	<b>19.5 W/kg <math>\pm</math> 16.5 % (k=2)</b>

## Body TSL parameters

The following parameters and calculations were applied.

	Temperature	Permittivity	Conductivity
<b>Nominal Body TSL parameters</b>	22.0 °C	53.4	1.49 mho/m
<b>Measured Body TSL parameters</b>	(22.0 $\pm$ 0.2) °C	51.8 $\pm$ 6 %	1.50 mho/m $\pm$ 6 %
<b>Body TSL temperature change during test</b>	< 0.5 °C	----	----

## SAR result with Body TSL

<b>SAR averaged over 1 cm<sup>3</sup> (1 g) of Body TSL</b>	Condition	
SAR measured	250 mW input power	9.55 W/kg
SAR for nominal Body TSL parameters	normalized to 1W	<b>37.8 W/kg <math>\pm</math> 17.0 % (k=2)</b>

<b>SAR averaged over 10 cm<sup>3</sup> (10 g) of Body TSL</b>	condition	
SAR measured	250 mW input power	5.13 W/kg
SAR for nominal Body TSL parameters	normalized to 1W	<b>20.4 W/kg <math>\pm</math> 16.5 % (k=2)</b>

## Appendix

### Antenna Parameters with Head TSL

Impedance, transformed to feed point	50.9 $\Omega$ + 0.3 j $\Omega$
Return Loss	- 40.7 dB

### Antenna Parameters with Body TSL

Impedance, transformed to feed point	47.0 $\Omega$ + 0.4 j $\Omega$
Return Loss	- 30.1 dB

### General Antenna Parameters and Design

Electrical Delay (one direction)	1.222 ns
----------------------------------	----------

After long term use with 100W radiated power, only a slight warming of the dipole near the feedpoint can be measured.

The dipole is made of standard semirigid coaxial cable. The center conductor of the feeding line is directly connected to the second arm of the dipole. The antenna is therefore short-circuited for DC-signals. On some of the dipoles, small end caps are added to the dipole arms in order to improve matching when loaded according to the position as explained in the "Measurement Conditions" paragraph. The SAR data are not affected by this change. The overall dipole length is still according to the Standard.

No excessive force must be applied to the dipole arms, because they might bend or the soldered connections near the feedpoint may be damaged.

### Additional EUT Data

Manufactured by	SPEAG
Manufactured on	February 19, 2010

## DASY5 Validation Report for Head TSL

Date: 30.04.2013

Test Laboratory: SPEAG, Zurich, Switzerland

**DUT: Dipole 1750 MHz; Type: D1750V2; Serial: D1750V2 - SN: 1051**

Communication System: UID 0 - CW; Frequency: 1750 MHz

Medium parameters used:  $f = 1750$  MHz;  $\sigma = 1.33$  S/m;  $\epsilon_r = 39.1$ ;  $\rho = 1000$  kg/m<sup>3</sup>

Phantom section: Flat Section

Measurement Standard: DASY5 (IEEE/IEC/ANSI C63.19-2007)

DASY52 Configuration:

- Probe: ES3DV3 - SN3205; ConvF(5.18, 5.18, 5.18); Calibrated: 28.12.2012;
- Sensor-Surface: 3mm (Mechanical Surface Detection)
- Electronics: DAE4 Sn601; Calibrated: 25.04.2013
- Phantom: Flat Phantom 5.0 (front); Type: QD000P50AA; Serial: 1001
- DASY52 52.8.6(1115); SEMCAD X 14.6.9(7117)

### **Dipole Calibration for Head Tissue/Pin=250 mW, d=10mm/Zoom Scan (8x7x7)/Cube 0:**

Measurement grid: dx=5mm, dy=5mm, dz=5mm

Reference Value = 90.104 V/m; Power Drift = 0.09 dB

Peak SAR (extrapolated) = 16.0 W/kg

**SAR(1 g) = 9.01 W/kg; SAR(10 g) = 4.83 W/kg**

Maximum value of SAR (measured) = 11.3 W/kg

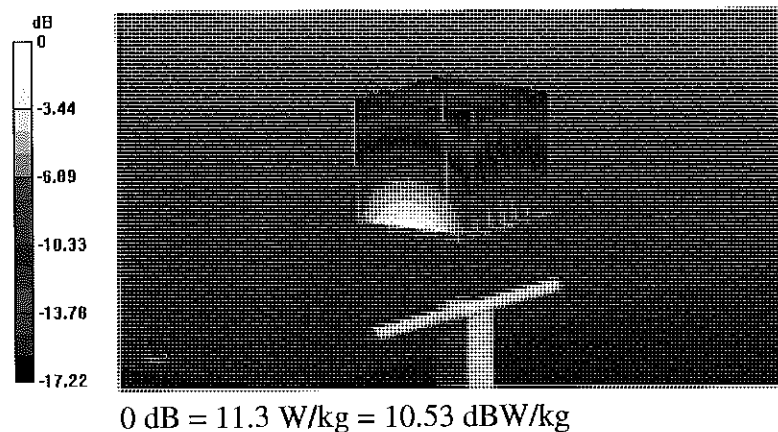

# Impedance Measurement Plot for Head TSL

30 Apr 2013 12:59:57

CH1 S11 1 U FS 1: 50.889  $\Omega$  0.2813  $\Omega$  25.578 pF 1 750.000 000 MHz

\*  
Del  
CA  
Avg  
4  
Hid

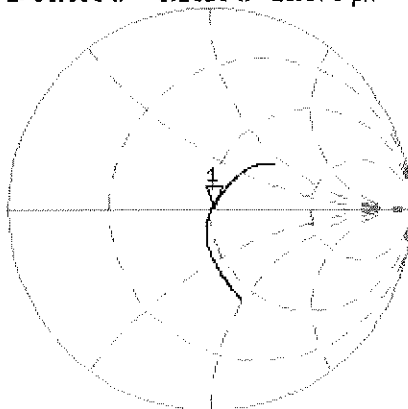

CH2 S11 LOG 5 dB/REF -20 dB 1:-40.692 dB 1 750.000 000 MHz

CA  
Avg  
4  
Hid

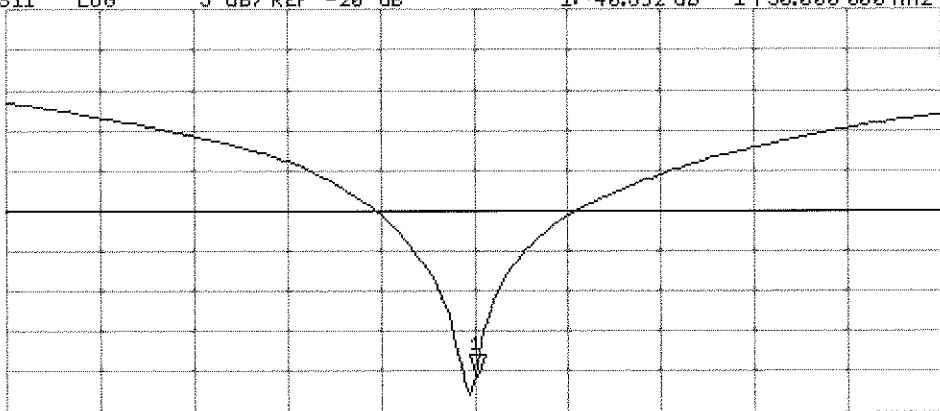

START 1 550.000 000 MHz

STOP 1 950.000 000 MHz

## DASY5 Validation Report for Body TSL

Date: 30.04.2013

Test Laboratory: SPEAG, Zurich, Switzerland

**DUT: Dipole 1750 MHz; Type: D1750V2; Serial: D1750V2 - SN: 1051**

Communication System: UID 0 - CW; Frequency: 1750 MHz

Medium parameters used:  $f = 1750$  MHz;  $\sigma = 1.5$  S/m;  $\epsilon_r = 51.8$ ;  $\rho = 1000$  kg/m<sup>3</sup>

Phantom section: Flat Section

Measurement Standard: DASY5 (IEEE/IEC/ANSI C63.19-2007)

DASY52 Configuration:

- Probe: ES3DV3 - SN3205; ConvF(4.83, 4.83, 4.83); Calibrated: 28.12.2012;
- Sensor-Surface: 3mm (Mechanical Surface Detection)
- Electronics: DAE4 Sn601; Calibrated: 25.04.2013
- Phantom: Flat Phantom 5.0 (back); Type: QD000P50AA; Serial: 1002
- DASY52 52.8.6(1115); SEMCAD X 14.6.9(7117)

### **Dipole Calibration for Body Tissue/Pin=250 mW, d=10mm/Zoom Scan (7x7x7)/Cube 0:**

Measurement grid: dx=5mm, dy=5mm, dz=5mm

Reference Value = 93.473 V/m; Power Drift = 0.01 dB

Peak SAR (extrapolated) = 16.4 W/kg

**SAR(1 g) = 9.55 W/kg; SAR(10 g) = 5.13 W/kg**

Maximum value of SAR (measured) = 12.0 W/kg

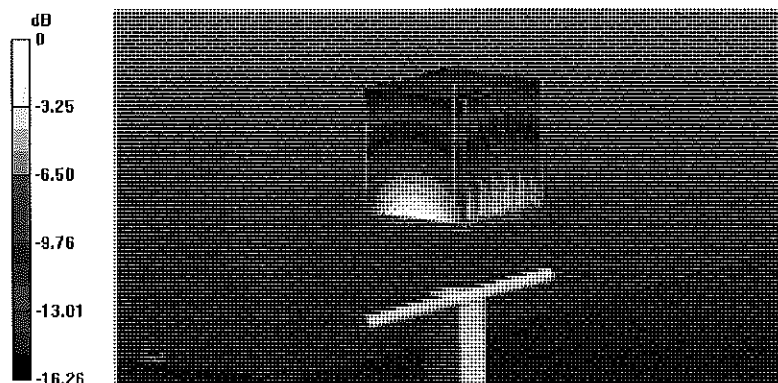

0 dB = 12.0 W/kg = 10.79 dBW/kg

# Impedance Measurement Plot for Body TSL

30 Apr 2013 12:59:14

CH1 S11 1 U FS

1: 46.998  $\Omega$  0.4160  $\Omega$  37.835 pF

1 750.000 000 MHz

\*  
De1

CA

Avg  
16

H1d

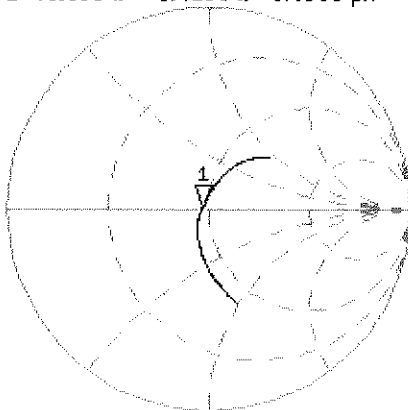

CH2 S11 LOG

5 dB/REF -20 dB

1: -30.102 dB 1 750.000 000 MHz

CA

Avg  
16

H1d

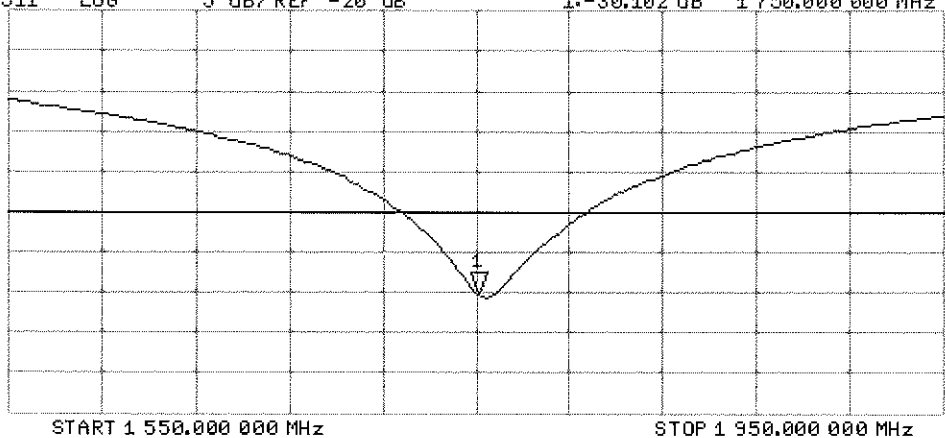



Accredited by the Swiss Accreditation Service (SAS)  
The Swiss Accreditation Service is one of the signatories to the EA  
Multilateral Agreement for the recognition of calibration certificates

Accreditation No.: **SCS 108**

Client **PC Test**

Certificate No: **D1900V2-5d149\_Jul13**

## CALIBRATION CERTIFICATE

Object: **D1900V2 - SN: 5d149**

Calibration procedure(s): **QA CAL-05.v9  
Calibration procedure for dipole validation kits above 700 MHz**

Calibration date: **July 22, 2013**

*✓  
Kok  
8/19/13*

This calibration certificate documents the traceability to national standards, which realize the physical units of measurements (SI).  
The measurements and the uncertainties with confidence probability are given on the following pages and are part of the certificate.

All calibrations have been conducted in the closed laboratory facility: environment temperature (22 ± 3)°C and humidity < 70%.

Calibration Equipment used (M&TE critical for calibration)

Primary Standards	ID #	Cal Date (Certificate No.)	Scheduled Calibration
Power meter EPM-442A	GB37480704	01-Nov-12 (No. 217-01640)	Oct-13
Power sensor HP 8481A	US37292783	01-Nov-12 (No. 217-01640)	Oct-13
Reference 20 dB Attenuator	SN: 5058 (20k)	04-Apr-13 (No. 217-01736)	Apr-14
Type-N mismatch combination	SN: 5047.3 / 06327	04-Apr-13 (No. 217-01739)	Apr-14
Reference Probe ES3DV3	SN: 3205	28-Dec-12 (No. ES3-3205_Dec12)	Dec-13
DAE4	SN: 601	25-Apr-13 (No. DAE4-601_Apr13)	Apr-14
Secondary Standards	ID #	Check Date (in house)	Scheduled Check
Power sensor HP 8481A	MY41092317	18-Oct-02 (in house check Oct-11)	In house check: Oct-13
RF generator R&S SMT-06	100005	04-Aug-99 (in house check Oct-11)	In house check: Oct-13
Network Analyzer HP 8753E	US37390585 S4206	18-Oct-01 (in house check Oct-12)	In house check: Oct-13

	<b>Name</b>	<b>Function</b>	<b>Signature</b>
Calibrated by:	Jeton Kastrati	Laboratory Technician	
Approved by:	Katja Pokovic	Technical Manager	

Issued: July 22, 2013

This calibration certificate shall not be reproduced except in full without written approval of the laboratory.



Accredited by the Swiss Accreditation Service (SAS)  
The Swiss Accreditation Service is one of the signatories to the EA  
Multilateral Agreement for the recognition of calibration certificates

Accreditation No.: **SCS 108**

**Glossary:**

TSL	tissue simulating liquid
ConvF	sensitivity in TSL / NORM x,y,z
N/A	not applicable or not measured

**Calibration is Performed According to the Following Standards:**

- a) IEEE Std 1528-2003, "IEEE Recommended Practice for Determining the Peak Spatial-Averaged Specific Absorption Rate (SAR) in the Human Head from Wireless Communications Devices: Measurement Techniques", December 2003
- b) IEC 62209-1, "Procedure to measure the Specific Absorption Rate (SAR) for hand-held devices used in close proximity to the ear (frequency range of 300 MHz to 3 GHz)", February 2005
- c) Federal Communications Commission Office of Engineering & Technology (FCC OET), "Evaluating Compliance with FCC Guidelines for Human Exposure to Radiofrequency Electromagnetic Fields; Additional Information for Evaluating Compliance of Mobile and Portable Devices with FCC Limits for Human Exposure to Radiofrequency Emissions", Supplement C (Edition 01-01) to Bulletin 65

**Additional Documentation:**

- d) DASY4/5 System Handbook

**Methods Applied and Interpretation of Parameters:**

- *Measurement Conditions:* Further details are available from the Validation Report at the end of the certificate. All figures stated in the certificate are valid at the frequency indicated.
- *Antenna Parameters with TSL:* The dipole is mounted with the spacer to position its feed point exactly below the center marking of the flat phantom section, with the arms oriented parallel to the body axis.
- *Feed Point Impedance and Return Loss:* These parameters are measured with the dipole positioned under the liquid filled phantom. The impedance stated is transformed from the measurement at the SMA connector to the feed point. The Return Loss ensures low reflected power. No uncertainty required.
- *Electrical Delay:* One-way delay between the SMA connector and the antenna feed point. No uncertainty required.
- *SAR measured:* SAR measured at the stated antenna input power.
- *SAR normalized:* SAR as measured, normalized to an input power of 1 W at the antenna connector.
- *SAR for nominal TSL parameters:* The measured TSL parameters are used to calculate the nominal SAR result.

The reported uncertainty of measurement is stated as the standard uncertainty of measurement multiplied by the coverage factor  $k=2$ , which for a normal distribution corresponds to a coverage probability of approximately 95%.

## Measurement Conditions

DASY system configuration, as far as not given on page 1.

<b>DASY Version</b>	DASY5	V52.8.7
<b>Extrapolation</b>	Advanced Extrapolation	
<b>Phantom</b>	Modular Flat Phantom	
<b>Distance Dipole Center - TSL</b>	10 mm	with Spacer
<b>Zoom Scan Resolution</b>	dx, dy, dz = 5 mm	
<b>Frequency</b>	1900 MHz $\pm$ 1 MHz	

## Head TSL parameters

The following parameters and calculations were applied.

	Temperature	Permittivity	Conductivity
<b>Nominal Head TSL parameters</b>	22.0 °C	40.0	1.40 mho/m
<b>Measured Head TSL parameters</b>	(22.0 $\pm$ 0.2) °C	38.9 $\pm$ 6 %	1.36 mho/m $\pm$ 6 %
<b>Head TSL temperature change during test</b>	< 0.5 °C	----	----

## SAR result with Head TSL

<b>SAR averaged over 1 cm<sup>3</sup> (1 g) of Head TSL</b>	Condition	
SAR measured	250 mW input power	9.99 W/kg
SAR for nominal Head TSL parameters	normalized to 1W	<b>40.4 W/kg <math>\pm</math> 17.0 % (k=2)</b>

<b>SAR averaged over 10 cm<sup>3</sup> (10 g) of Head TSL</b>	condition	
SAR measured	250 mW input power	5.28 W/kg
SAR for nominal Head TSL parameters	normalized to 1W	<b>21.3 W/kg <math>\pm</math> 16.5 % (k=2)</b>

## Body TSL parameters

The following parameters and calculations were applied.

	Temperature	Permittivity	Conductivity
<b>Nominal Body TSL parameters</b>	22.0 °C	53.3	1.52 mho/m
<b>Measured Body TSL parameters</b>	(22.0 $\pm$ 0.2) °C	53.4 $\pm$ 6 %	1.49 mho/m $\pm$ 6 %
<b>Body TSL temperature change during test</b>	< 0.5 °C	----	----

## SAR result with Body TSL

<b>SAR averaged over 1 cm<sup>3</sup> (1 g) of Body TSL</b>	Condition	
SAR measured	250 mW input power	10.0 W/kg
SAR for nominal Body TSL parameters	normalized to 1W	<b>40.5 W/kg <math>\pm</math> 17.0 % (k=2)</b>

<b>SAR averaged over 10 cm<sup>3</sup> (10 g) of Body TSL</b>	condition	
SAR measured	250 mW input power	5.36 W/kg
SAR for nominal Body TSL parameters	normalized to 1W	<b>21.6 W/kg <math>\pm</math> 16.5 % (k=2)</b>

## Appendix

### Antenna Parameters with Head TSL

Impedance, transformed to feed point	52.9 $\Omega$ + 6.0 j $\Omega$
Return Loss	- 23.8 dB

### Antenna Parameters with Body TSL

Impedance, transformed to feed point	48.5 $\Omega$ + 6.4 j $\Omega$
Return Loss	- 23.5 dB

### General Antenna Parameters and Design

Electrical Delay (one direction)	1.196 ns
----------------------------------	----------

After long term use with 100W radiated power, only a slight warming of the dipole near the feedpoint can be measured.

The dipole is made of standard semirigid coaxial cable. The center conductor of the feeding line is directly connected to the second arm of the dipole. The antenna is therefore short-circuited for DC-signals. On some of the dipoles, small end caps are added to the dipole arms in order to improve matching when loaded according to the position as explained in the "Measurement Conditions" paragraph. The SAR data are not affected by this change. The overall dipole length is still according to the Standard.

No excessive force must be applied to the dipole arms, because they might bend or the soldered connections near the feedpoint may be damaged.

### Additional EUT Data

Manufactured by	SPEAG
Manufactured on	March 11, 2011

## DASY5 Validation Report for Head TSL

Date: 22.07.2013

Test Laboratory: SPEAG, Zurich, Switzerland

**DUT: Dipole 1900 MHz; Type: D1900V2; Serial: D1900V2 - SN: 5d149**

Communication System: UID 0 - CW ; Frequency: 1900 MHz

Medium parameters used:  $f = 1900$  MHz;  $\sigma = 1.36$  S/m;  $\epsilon_r = 38.9$ ;  $\rho = 1000$  kg/m<sup>3</sup>

Phantom section: Flat Section

Measurement Standard: DASY5 (IEEE/IEC/ANSI C63.19-2007)

DASY52 Configuration:

- Probe: ES3DV3 - SN3205; ConvF(4.98, 4.98, 4.98); Calibrated: 28.12.2012;
- Sensor-Surface: 3mm (Mechanical Surface Detection)
- Electronics: DAE4 Sn601; Calibrated: 25.04.2013
- Phantom: Flat Phantom 5.0 (front); Type: QD000P50AA; Serial: 1001
- DASY52 52.8.7(1137); SEMCAD X 14.6.10(7164)

### **Dipole Calibration for Head Tissue/Pin=250 mW, d=10mm/Zoom Scan (7x7x7)/Cube 0:**

Measurement grid: dx=5mm, dy=5mm, dz=5mm

Reference Value = 96.173 V/m; Power Drift = 0.04 dB

Peak SAR (extrapolated) = 18.0 W/kg

**SAR(1 g) = 9.99 W/kg; SAR(10 g) = 5.28 W/kg**

Maximum value of SAR (measured) = 12.4 W/kg

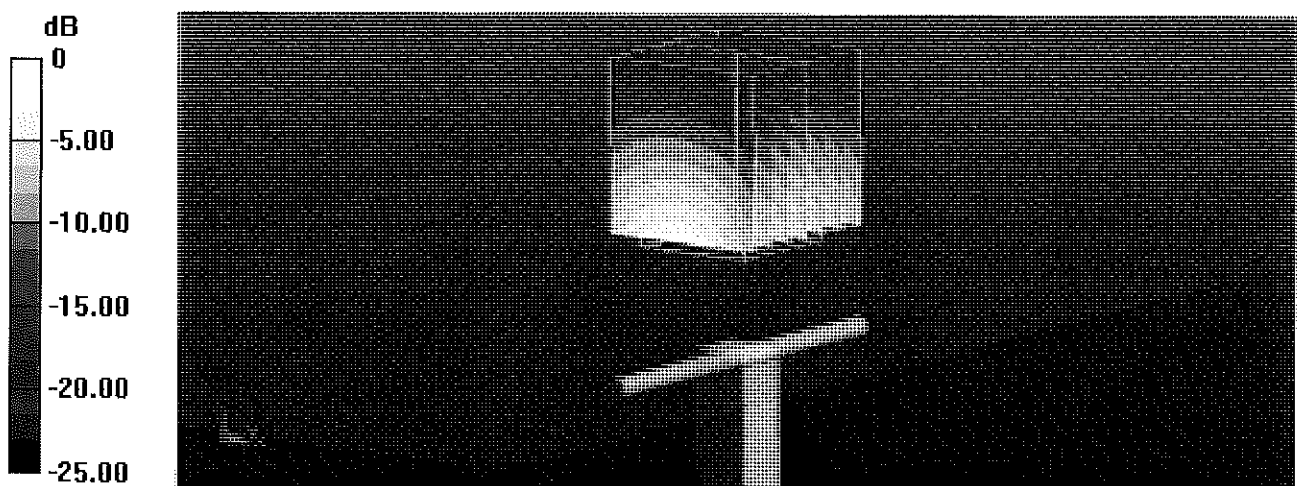

0 dB = 12.4 W/kg = 10.93 dBW/kg

# Impedance Measurement Plot for Head TSL

22 Jul 2013 11:59:34

CH1 S11 1 U FS 1: 52.941  $\Omega$  6.0059  $\Omega$  503.09  $\rho H$  1 900.000 000 MHz

\*  
De1  
CA  
Avg  
16  
H1d

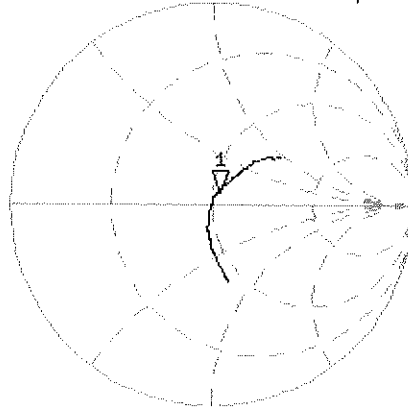

CH2 S11 LOG 5 dB/REF -20 dB 1:-23.758 dB 1 900.000 000 MHz

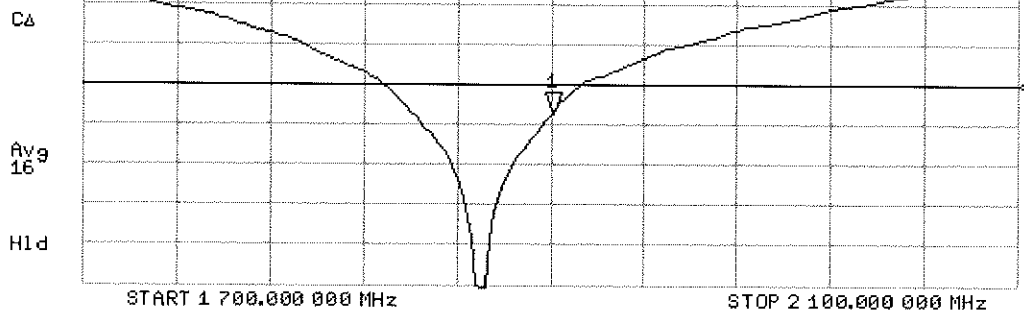

# DASY5 Validation Report for Body TSL

Date: 22.07.2013

Test Laboratory: SPEAG, Zurich, Switzerland

**DUT: Dipole 1900 MHz; Type: D1900V2; Serial: D1900V2 - SN: 5d149**

Communication System: UID 0 - CW ; Frequency: 1900 MHz

Medium parameters used:  $f = 1900$  MHz;  $\sigma = 1.49$  S/m;  $\epsilon_r = 53.4$ ;  $\rho = 1000$  kg/m<sup>3</sup>

Phantom section: Flat Section

Measurement Standard: DASY5 (IEEE/IEC/ANSI C63.19-2007)

DASY52 Configuration:

- Probe: ES3DV3 - SN3205; ConvF(4.6, 4.6, 4.6); Calibrated: 28.12.2012;
- Sensor-Surface: 3mm (Mechanical Surface Detection)
- Electronics: DAE4 Sn601; Calibrated: 25.04.2013
- Phantom: Flat Phantom 5.0 (back); Type: QD000P50AA; Serial: 1002
- DASY52 52.8.7(1137); SEMCAD X 14.6.10(7164)

## Dipole Calibration for Body Tissue/Pin=250 mW, d=10mm/Zoom Scan (7x7x7)/Cube 0:

Measurement grid: dx=5mm, dy=5mm, dz=5mm

Reference Value = 96.173 V/m; Power Drift = 0.01 dB

Peak SAR (extrapolated) = 17.0 W/kg

**SAR(1 g) = 10 W/kg; SAR(10 g) = 5.36 W/kg**

Maximum value of SAR (measured) = 12.6 W/kg

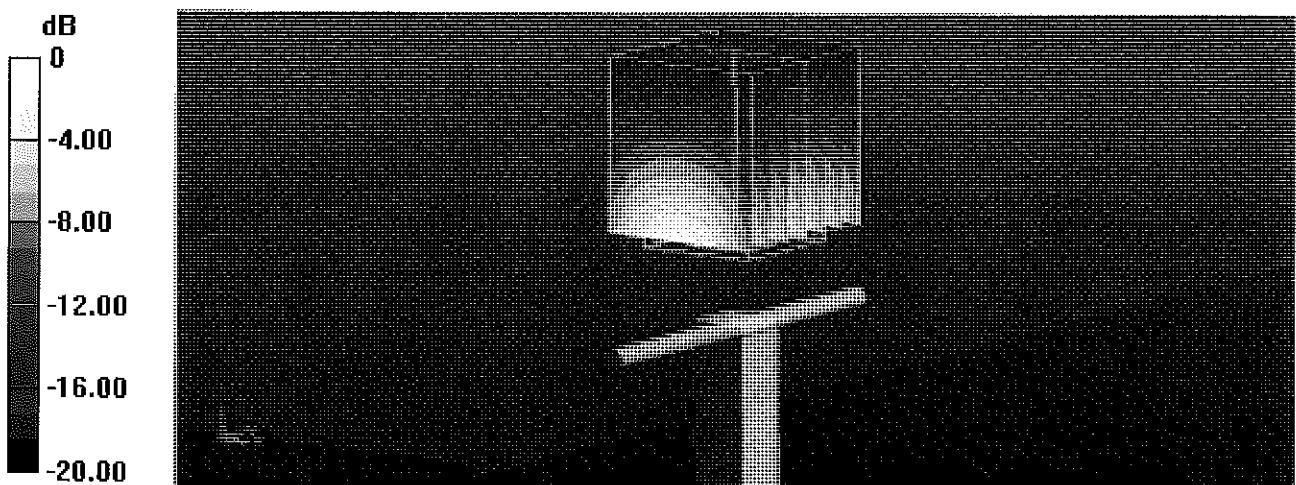

0 dB = 12.6 W/kg = 11.00 dBW/kg

# Impedance Measurement Plot for Body TSL

22 Jul 2013 11:32:14

CH1 S11 1 U FS 1: 48.525  $\Omega$  6.3906  $\mu$  535.32 pF 1 900.000 000 MHz

\*  
De1  
CA

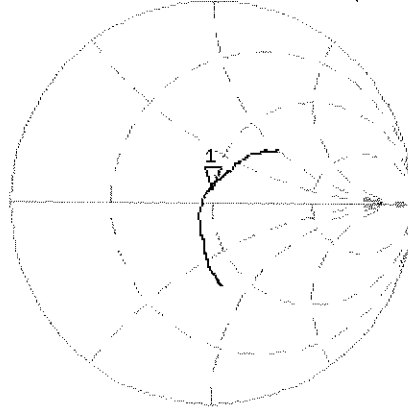

Avg  
16

H1d

CH2 S11 LOG 5 dB/REF -20 dB 1:-23.547 dB 1 900.000 000 MHz

CA

Avg  
16

H1d

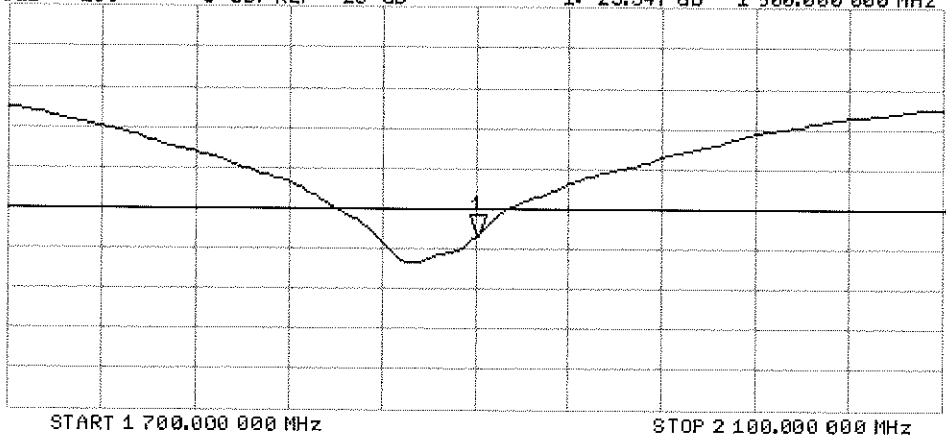



Accredited by the Swiss Accreditation Service (SAS)  
The Swiss Accreditation Service is one of the signatories to the EA  
Multilateral Agreement for the recognition of calibration certificates

Accreditation No.: **SCS 108**

Client **PC Test**

Certificate No: **D2450V2-719\_Aug13**

## CALIBRATION CERTIFICATE

Object **D2450V2 - SN: 719**

Calibration procedure(s) **QA CAL-05.v9  
Calibration procedure for dipole validation kits above 700 MHz**

Calibration date: **August 23, 2013**

*✓cc  
9/13/13*

This calibration certificate documents the traceability to national standards, which realize the physical units of measurements (SI).  
The measurements and the uncertainties with confidence probability are given on the following pages and are part of the certificate.

All calibrations have been conducted in the closed laboratory facility: environment temperature (22 ± 3)°C and humidity < 70%.

Calibration Equipment used (M&TE critical for calibration)

Primary Standards	ID #	Cal Date (Certificate No.)	Scheduled Calibration
Power meter EPM-442A	GB37480704	01-Nov-12 (No. 217-01640)	Oct-13
Power sensor HP 8481A	US37292783	01-Nov-12 (No. 217-01640)	Oct-13
Reference 20 dB Attenuator	SN: 5058 (20k)	04-Apr-13 (No. 217-01736)	Apr-14
Type-N mismatch combination	SN: 5047.3 / 06327	04-Apr-13 (No. 217-01739)	Apr-14
Reference Probe ES3DV3	SN: 3205	28-Dec-12 (No. ES3-3205_Dec12)	Dec-13
DAE4	SN: 601	25-Apr-13 (No. DAE4-601_Apr13)	Apr-14
Secondary Standards	ID #	Check Date (in house)	Scheduled Check
Power sensor HP 8481A	MY41092317	18-Oct-02 (in house check Oct-11)	In house check: Oct-13
RF generator R&S SMT-06	100005	04-Aug-99 (in house check Oct-11)	In house check: Oct-13
Network Analyzer HP 8753E	US37390585 S4206	18-Oct-01 (in house check Oct-12)	In house check: Oct-13

Calibrated by:	Name <b>Jeton Kastrati</b>	Function Laboratory Technician	Signature 
Approved by:	Name <b>Katja Pokovic</b>	Function Technical Manager	Signature 

Issued: August 23, 2013

This calibration certificate shall not be reproduced except in full without written approval of the laboratory.



Accredited by the Swiss Accreditation Service (SAS)

The Swiss Accreditation Service is one of the signatories to the EA  
Multilateral Agreement for the recognition of calibration certificates

Accreditation No.: **SCS 108**

### Glossary:

TSL	tissue simulating liquid
ConvF	sensitivity in TSL / NORM x,y,z
N/A	not applicable or not measured

### Calibration is Performed According to the Following Standards:

- IEEE Std 1528-2003, "IEEE Recommended Practice for Determining the Peak Spatial-Averaged Specific Absorption Rate (SAR) in the Human Head from Wireless Communications Devices: Measurement Techniques", December 2003
- IEC 62209-1, "Procedure to measure the Specific Absorption Rate (SAR) for hand-held devices used in close proximity to the ear (frequency range of 300 MHz to 3 GHz)", February 2005
- KDB 865664, "SAR Measurement Requirements for 100 MHz to 6 GHz"

### Additional Documentation:

- DASY4/5 System Handbook

### Methods Applied and Interpretation of Parameters:

- Measurement Conditions:* Further details are available from the Validation Report at the end of the certificate. All figures stated in the certificate are valid at the frequency indicated.
- Antenna Parameters with TSL:* The dipole is mounted with the spacer to position its feed point exactly below the center marking of the flat phantom section, with the arms oriented parallel to the body axis.
- Feed Point Impedance and Return Loss:* These parameters are measured with the dipole positioned under the liquid filled phantom. The impedance stated is transformed from the measurement at the SMA connector to the feed point. The Return Loss ensures low reflected power. No uncertainty required.
- Electrical Delay:* One-way delay between the SMA connector and the antenna feed point. No uncertainty required.
- SAR measured:* SAR measured at the stated antenna input power.
- SAR normalized:* SAR as measured, normalized to an input power of 1 W at the antenna connector.
- SAR for nominal TSL parameters:* The measured TSL parameters are used to calculate the nominal SAR result.

The reported uncertainty of measurement is stated as the standard uncertainty of measurement multiplied by the coverage factor  $k=2$ , which for a normal distribution corresponds to a coverage probability of approximately 95%.

## Measurement Conditions

DASY system configuration, as far as not given on page 1.

<b>DASY Version</b>	DASY5	V52.8.7
<b>Extrapolation</b>	Advanced Extrapolation	
<b>Phantom</b>	Modular Flat Phantom	
<b>Distance Dipole Center - TSL</b>	10 mm	with Spacer
<b>Zoom Scan Resolution</b>	dx, dy, dz = 5 mm	
<b>Frequency</b>	2450 MHz $\pm$ 1 MHz	

## Head TSL parameters

The following parameters and calculations were applied.

	Temperature	Permittivity	Conductivity
<b>Nominal Head TSL parameters</b>	22.0 °C	39.2	1.80 mho/m
<b>Measured Head TSL parameters</b>	(22.0 $\pm$ 0.2) °C	37.8 $\pm$ 6 %	1.80 mho/m $\pm$ 6 %
<b>Head TSL temperature change during test</b>	< 0.5 °C	----	----

## SAR result with Head TSL

<b>SAR averaged over 1 cm<sup>3</sup> (1 g) of Head TSL</b>	Condition	
SAR measured	250 mW input power	13.4 W/kg
SAR for nominal Head TSL parameters	normalized to 1W	<b>53.2 W/kg <math>\pm</math> 17.0 % (k=2)</b>

<b>SAR averaged over 10 cm<sup>3</sup> (10 g) of Head TSL</b>	condition	
SAR measured	250 mW input power	6.23 W/kg
SAR for nominal Head TSL parameters	normalized to 1W	<b>24.8 W/kg <math>\pm</math> 16.5 % (k=2)</b>

## Body TSL parameters

The following parameters and calculations were applied.

	Temperature	Permittivity	Conductivity
<b>Nominal Body TSL parameters</b>	22.0 °C	52.7	1.95 mho/m
<b>Measured Body TSL parameters</b>	(22.0 $\pm$ 0.2) °C	50.6 $\pm$ 6 %	2.03 mho/m $\pm$ 6 %
<b>Body TSL temperature change during test</b>	< 0.5 °C	----	----

## SAR result with Body TSL

<b>SAR averaged over 1 cm<sup>3</sup> (1 g) of Body TSL</b>	Condition	
SAR measured	250 mW input power	13.3 W/kg
SAR for nominal Body TSL parameters	normalized to 1W	<b>51.7 W/kg <math>\pm</math> 17.0 % (k=2)</b>

<b>SAR averaged over 10 cm<sup>3</sup> (10 g) of Body TSL</b>	condition	
SAR measured	250 mW input power	6.14 W/kg
SAR for nominal Body TSL parameters	normalized to 1W	<b>24.1 W/kg <math>\pm</math> 16.5 % (k=2)</b>

## Appendix

### Antenna Parameters with Head TSL

Impedance, transformed to feed point	54.6 $\Omega$ + 3.5 j $\Omega$
Return Loss	- 25.1 dB

### Antenna Parameters with Body TSL

Impedance, transformed to feed point	51.1 $\Omega$ + 5.4 j $\Omega$
Return Loss	- 25.3 dB

### General Antenna Parameters and Design

Electrical Delay (one direction)	1.149 ns
----------------------------------	----------

After long term use with 100W radiated power, only a slight warming of the dipole near the feedpoint can be measured.

The dipole is made of standard semirigid coaxial cable. The center conductor of the feeding line is directly connected to the second arm of the dipole. The antenna is therefore short-circuited for DC-signals. On some of the dipoles, small end caps are added to the dipole arms in order to improve matching when loaded according to the position as explained in the "Measurement Conditions" paragraph. The SAR data are not affected by this change. The overall dipole length is still according to the Standard.

No excessive force must be applied to the dipole arms, because they might bend or the soldered connections near the feedpoint may be damaged.

### Additional EUT Data

Manufactured by	SPEAG
Manufactured on	September 10, 2002

## DASY5 Validation Report for Head TSL

Date: 22.08.2013

Test Laboratory: SPEAG, Zurich, Switzerland

**DUT: Dipole 2450 MHz; Type: D2450V2; Serial: D2450V2 - SN: 719**

Communication System: UID 0 - CW ; Frequency: 2450 MHz

Medium parameters used:  $f = 2450$  MHz;  $\sigma = 1.8$  S/m;  $\epsilon_r = 37.8$ ;  $\rho = 1000$  kg/m<sup>3</sup>

Phantom section: Flat Section

Measurement Standard: DASY5 (IEEE/IEC/ANSI C63.19-2007)

DASY52 Configuration:

- Probe: ES3DV3 - SN3205; ConvF(4.52, 4.52, 4.52); Calibrated: 28.12.2012;
- Sensor-Surface: 3mm (Mechanical Surface Detection)
- Electronics: DAE4 Sn601; Calibrated: 25.04.2013
- Phantom: Flat Phantom 5.0 (front); Type: QD000P50AA; Serial: 1001
- DASY52 52.8.7(1137); SEMCAD X 14.6.10(7164)

### Dipole Calibration for Head Tissue/Pin=250 mW, d=10mm/Zoom Scan (7x7x7)/Cube 0:

Measurement grid: dx=5mm, dy=5mm, dz=5mm

Reference Value = 100.7 V/m; Power Drift = 0.06 dB

Peak SAR (extrapolated) = 27.9 W/kg

**SAR(1 g) = 13.4 W/kg; SAR(10 g) = 6.23 W/kg**

Maximum value of SAR (measured) = 17.0 W/kg

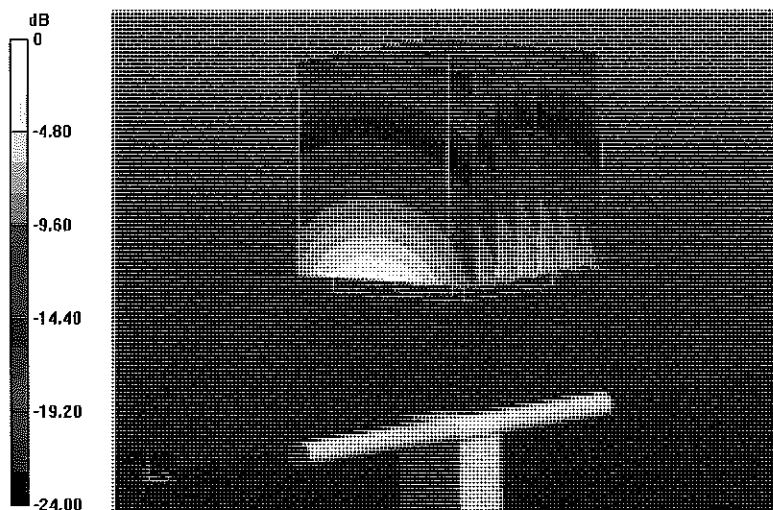

# Impedance Measurement Plot for Head TSL

22 Aug 2013 11:00:15

CH1 S11 1 U FS

4: 54.639  $\Omega$  3.5215  $\Omega$  228.76 pF

2 450.000 000 MHz

\*  
De1

CA

Avg  
16

H1d

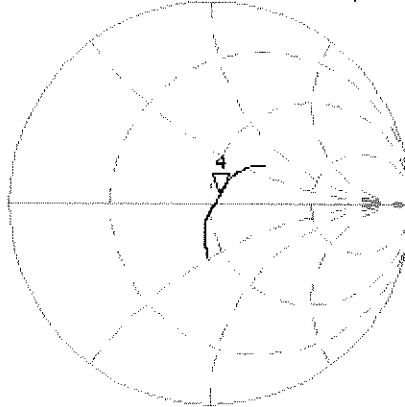

CH2 S11 LOG

5 dB/REF -20 dB

4: -25.093 dB 2 450.000 000 MHz

CA

Avg  
16

H1d

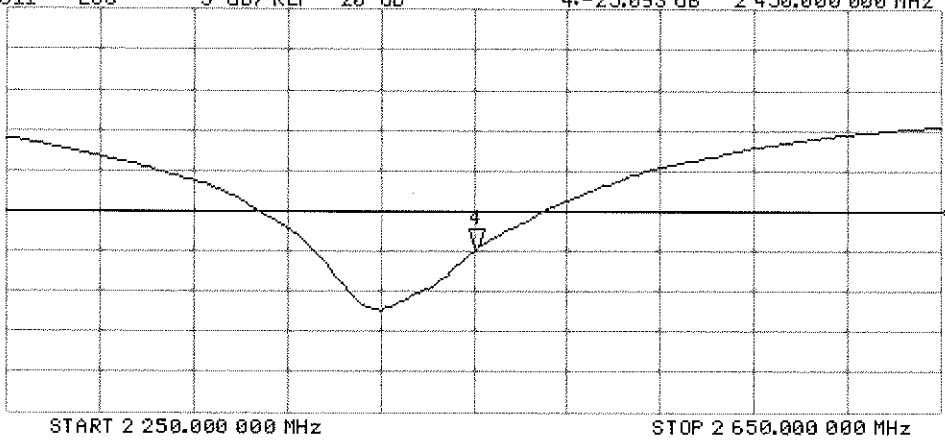

# DASY5 Validation Report for Body TSL

Date: 23.08.2013

Test Laboratory: SPEAG, Zurich, Switzerland

**DUT: Dipole 2450 MHz; Type: D2450V2; Serial: D2450V2 - SN: 719**

Communication System: UID 0 - CW ; Frequency: 2450 MHz

Medium parameters used:  $f = 2450$  MHz;  $\sigma = 2.03$  S/m;  $\epsilon_r = 50.6$ ;  $\rho = 1000$  kg/m<sup>3</sup>

Phantom section: Flat Section

Measurement Standard: DASY5 (IEEE/IEC/ANSI C63.19-2007)

DASY52 Configuration:

- Probe: ES3DV3 - SN3205; ConvF(4.42, 4.42, 4.42); Calibrated: 28.12.2012;
- Sensor-Surface: 3mm (Mechanical Surface Detection)
- Electronics: DAE4 Sn601; Calibrated: 25.04.2013
- Phantom: Flat Phantom 5.0 (back); Type: QD000P50AA; Serial: 1002
- DASY52 52.8.7(1137); SEMCAD X 14.6.10(7164)

## Dipole Calibration for Body Tissue/Pin=250 mW, d=10mm/Zoom Scan (7x7x7)/Cube 0:

Measurement grid: dx=5mm, dy=5mm, dz=5mm

Reference Value = 94.688 V/m; Power Drift = 0.06 dB

Peak SAR (extrapolated) = 27.9 W/kg

**SAR(1 g) = 13.3 W/kg; SAR(10 g) = 6.14 W/kg**

Maximum value of SAR (measured) = 17.2 W/kg

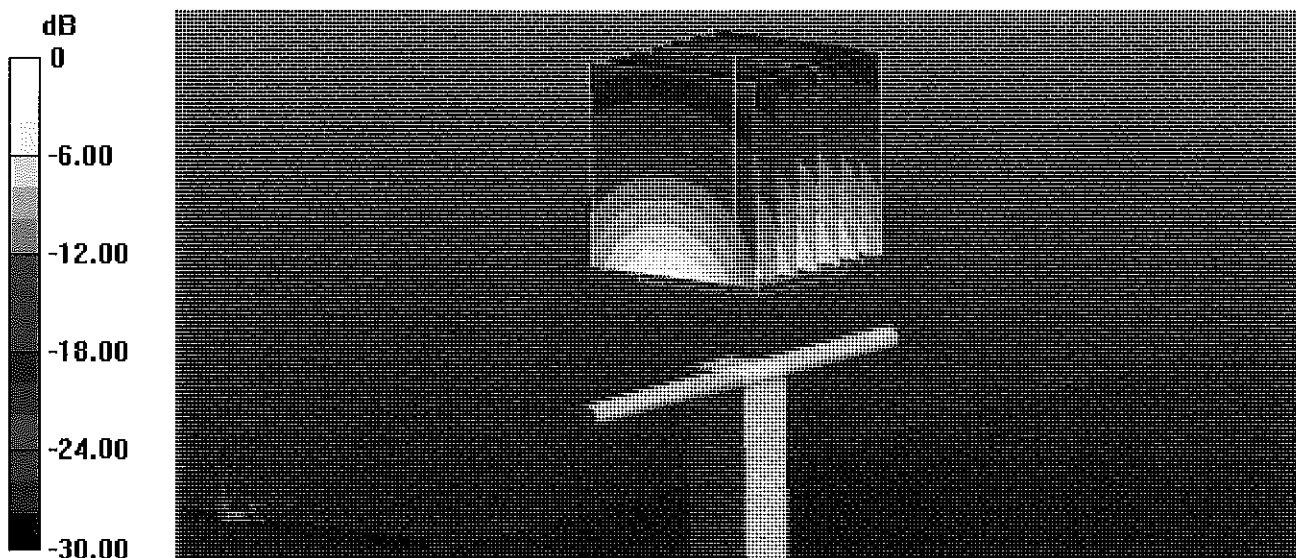

0 dB = 17.2 W/kg = 12.36 dBW/kg

# Impedance Measurement Plot for Body TSL

23 Aug 2013 09:00:38

CH1 S11 1 U FS

3: 51.135  $\Omega$  5.3965  $\Omega$  350.56 pF

2 450.000 000 MHz

#

De1

CΔ

Avg  
16

H1 d

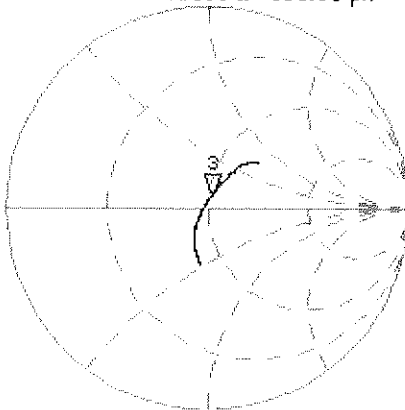

CH2 S11 LOG

5 dB/REF -20 dB

3:-25.274 dB

2 450.000 000 MHz

CΔ

Avg  
16

H1 d

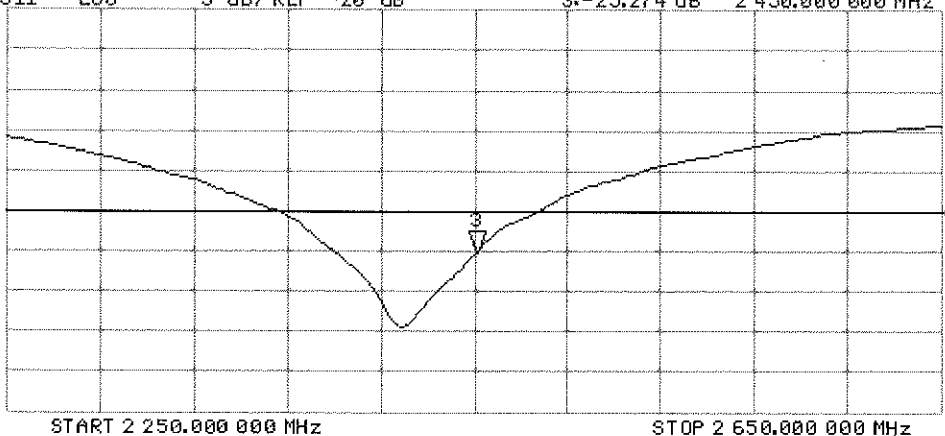



Accredited by the Swiss Accreditation Service (SAS)  
The Swiss Accreditation Service is one of the signatories to the EA  
Multilateral Agreement for the recognition of calibration certificates

Accreditation No.: **SCS 108**

Client **PC Test**

Certificate No: **ES3-3318\_Apr13**

**CALIBRATION CERTIFICATE**

Object: **ES3DV3 - SN:3318**

Calibration procedure(s): **QA CAL-01.v8, QA CAL-23.v4, QA CAL-25.v4  
Calibration procedure for dosimetric E-field probes**

Calibration date: **April 29, 2013**

This calibration certificate documents the traceability to national standards, which realize the physical units of measurements (SI).  
The measurements and the uncertainties with confidence probability are given on the following pages and are part of the certificate.

All calibrations have been conducted in the closed laboratory facility: environment temperature (22 ± 3)°C and humidity < 70%.

Calibration Equipment used (M&TE critical for calibration)

VCC  
6/14/13

Primary Standards	ID	Cal Date (Certificate No.)	Scheduled Calibration
Power meter E4419B	GB41293874	04-Apr-13 (No. 217-01733)	Apr-14
Power sensor E4412A	MY41498087	04-Apr-13 (No. 217-01733)	Apr-14
Reference 3 dB Attenuator	SN: S5054 (3c)	04-Apr-13 (No. 217-01737)	Apr-14
Reference 20 dB Attenuator	SN: S5277 (20x)	04-Apr-13 (No. 217-01735)	Apr-14
Reference 30 dB Attenuator	SN: S5129 (30b)	04-Apr-13 (No. 217-01738)	Apr-14
Reference Probe ES3DV2	SN: 3013	28-Dec-12 (No. ES3-3013_Dec12)	Dec-13
DAE4	SN: 660	31-Jan-13 (No. DAE4-660_Jan13)	Jan-14
Secondary Standards	ID	Check Date (in house)	Scheduled Check
RF generator HP 8648C	US3642U01700	4-Aug-99 (in house check Apr-13)	In house check: Apr-15
Network Analyzer HP 8753E	US37390585	18-Oct-01 (in house check Oct-12)	In house check: Oct-13

	Name	Function	Signature
Calibrated by:	Dimce Iliev	Laboratory Technician	
Approved by:	Katja Pokovic	Technical Manager	

Issued: April 29, 2013

This calibration certificate shall not be reproduced except in full without written approval of the laboratory.



Accredited by the Swiss Accreditation Service (SAS)

Accreditation No.: **SCS 108**

The Swiss Accreditation Service is one of the signatories to the EA  
 Multilateral Agreement for the recognition of calibration certificates

### Glossary:

TSL	tissue simulating liquid
NORM <sub>x,y,z</sub>	sensitivity in free space
ConvF	sensitivity in TSL / NORM <sub>x,y,z</sub>
DCP	diode compression point
CF	crest factor (1/duty_cycle) of the RF signal
A, B, C, D	modulation dependent linearization parameters
Polarization $\varphi$	$\varphi$ rotation around probe axis
Polarization $\vartheta$	$\vartheta$ rotation around an axis that is in the plane normal to probe axis (at measurement center), i.e., $\vartheta = 0$ is normal to probe axis

### Calibration is Performed According to the Following Standards:

- IEEE Std 1528-2003, "IEEE Recommended Practice for Determining the Peak Spatial-Averaged Specific Absorption Rate (SAR) in the Human Head from Wireless Communications Devices: Measurement Techniques", December 2003
- IEC 62209-1, "Procedure to measure the Specific Absorption Rate (SAR) for hand-held devices used in close proximity to the ear (frequency range of 300 MHz to 3 GHz)", February 2005

### Methods Applied and Interpretation of Parameters:

- NORM<sub>x,y,z</sub>**: Assessed for E-field polarization  $\vartheta = 0$  ( $f \leq 900$  MHz in TEM-cell;  $f > 1800$  MHz: R22 waveguide). NORM<sub>x,y,z</sub> are only intermediate values, i.e., the uncertainties of NORM<sub>x,y,z</sub> does not affect the E<sup>2</sup>-field uncertainty inside TSL (see below ConvF).
- NORM(f)<sub>x,y,z</sub>** = NORM<sub>x,y,z</sub> \* frequency\_response (see Frequency Response Chart). This linearization is implemented in DASY4 software versions later than 4.2. The uncertainty of the frequency response is included in the stated uncertainty of ConvF.
- DCP<sub>x,y,z</sub>**: DCP are numerical linearization parameters assessed based on the data of power sweep with CW signal (no uncertainty required). DCP does not depend on frequency nor media.
- PAR**: PAR is the Peak to Average Ratio that is not calibrated but determined based on the signal characteristics
- A<sub>x,y,z</sub>; B<sub>x,y,z</sub>; C<sub>x,y,z</sub>; D<sub>x,y,z</sub>; VR<sub>x,y,z</sub>; A, B, C, D** are numerical linearization parameters assessed based on the data of power sweep for specific modulation signal. The parameters do not depend on frequency nor media. VR is the maximum calibration range expressed in RMS voltage across the diode.
- ConvF and Boundary Effect Parameters**: Assessed in flat phantom using E-field (or Temperature Transfer Standard for  $f \leq 800$  MHz) and inside waveguide using analytical field distributions based on power measurements for  $f > 800$  MHz. The same setups are used for assessment of the parameters applied for boundary compensation (alpha, depth) of which typical uncertainty values are given. These parameters are used in DASY4 software to improve probe accuracy close to the boundary. The sensitivity in TSL corresponds to NORM<sub>x,y,z</sub> \* ConvF whereby the uncertainty corresponds to that given for ConvF. A frequency dependent ConvF is used in DASY version 4.4 and higher which allows extending the validity from  $\pm 50$  MHz to  $\pm 100$  MHz.
- Spherical isotropy (3D deviation from isotropy)**: in a field of low gradients realized using a flat phantom exposed by a patch antenna.
- Sensor Offset**: The sensor offset corresponds to the offset of virtual measurement center from the probe tip (on probe axis). No tolerance required.

# Probe ES3DV3

## SN:3318

Manufactured: January 10, 2012  
Calibrated: April 29, 2013

**Calibrated for DASV/EASY Systems**  
(Note: non-compatible with DASV2 system!)

## DASY/EASY - Parameters of Probe: ES3DV3 - SN:3318

### Basic Calibration Parameters

	Sensor X	Sensor Y	Sensor Z	Unc (k=2)
Norm ( $\mu\text{V}/(\text{V}/\text{m})^2$ ) <sup>A</sup>	1.15	0.92	1.29	± 10.1 %
DCP (mV) <sup>B</sup>	102.6	105.4	100.8	

### Modulation Calibration Parameters

UID	Communication System Name		A dB	B dB/ $\mu\text{V}$	C	D dB	VR mV	Unc <sup>E</sup> (k=2)
0	CW	X	0.0	0.0	1.0	0.00	153.6	±3.5 %
		Y	0.0	0.0	1.0		133.8	
		Z	0.0	0.0	1.0		154.8	

The reported uncertainty of measurement is stated as the standard uncertainty of measurement multiplied by the coverage factor k=2, which for a normal distribution corresponds to a coverage probability of approximately 95%.

<sup>A</sup> The uncertainties of NormX,Y,Z do not affect the E<sup>2</sup>-field uncertainty inside TSL (see Pages 5 and 6).

<sup>B</sup> Numerical linearization parameter: uncertainty not required.

<sup>E</sup> Uncertainty is determined using the max. deviation from linear response applying rectangular distribution and is expressed for the square of the field value.

## DASY/EASY - Parameters of Probe: ES3DV3 - SN:3318

### Calibration Parameter Determined in Head Tissue Simulating Media

f (MHz) <sup>C</sup>	Relative Permittivity <sup>F</sup>	Conductivity (S/m) <sup>F</sup>	ConvF X	ConvF Y	ConvF Z	Alpha	Depth (mm)	Unct. (k=2)
750	41.9	0.89	6.59	6.59	6.59	0.25	2.12	± 12.0 %
850	41.5	0.92	6.33	6.33	6.33	0.57	1.25	± 12.0 %
1900	40.0	1.40	5.22	5.22	5.22	0.79	1.25	± 12.0 %
2450	39.2	1.80	4.59	4.59	4.59	0.80	1.30	± 12.0 %

<sup>C</sup> Frequency validity of ± 100 MHz only applies for DASY v4.4 and higher (see Page 2), else it is restricted to ± 50 MHz. The uncertainty is the RSS of the ConvF uncertainty at calibration frequency and the uncertainty for the indicated frequency band.

<sup>F</sup> At frequencies below 3 GHz, the validity of tissue parameters ( $\epsilon$  and  $\sigma$ ) can be relaxed to ± 10% if liquid compensation formula is applied to measured SAR values. At frequencies above 3 GHz, the validity of tissue parameters ( $\epsilon$  and  $\sigma$ ) is restricted to ± 5%. The uncertainty is the RSS of the ConvF uncertainty for indicated target tissue parameters.

## DASY/EASY - Parameters of Probe: ES3DV3 - SN:3318

### Calibration Parameter Determined in Body Tissue Simulating Media

f (MHz) <sup>C</sup>	Relative Permittivity <sup>F</sup>	Conductivity (S/m) <sup>F</sup>	ConvF X	ConvF Y	ConvF Z	Alpha	Depth (mm)	Unct. (k=2)
750	55.5	0.96	6.35	6.35	6.35	0.53	1.42	± 12.0 %
850	55.2	0.99	6.21	6.21	6.21	0.57	1.38	± 12.0 %
1900	53.3	1.52	4.79	4.79	4.79	0.46	1.77	± 12.0 %
2450	52.7	1.95	4.31	4.31	4.31	0.80	1.09	± 12.0 %

<sup>C</sup> Frequency validity of ± 100 MHz only applies for DASY v4.4 and higher (see Page 2), else it is restricted to ± 50 MHz. The uncertainty is the RSS of the ConvF uncertainty at calibration frequency and the uncertainty for the indicated frequency band.

<sup>F</sup> At frequencies below 3 GHz, the validity of tissue parameters ( $\epsilon$  and  $\sigma$ ) can be relaxed to ± 10% if liquid compensation formula is applied to measured SAR values. At frequencies above 3 GHz, the validity of tissue parameters ( $\epsilon$  and  $\sigma$ ) is restricted to ± 5%. The uncertainty is the RSS of the ConvF uncertainty for indicated target tissue parameters.

### Frequency Response of E-Field (TEM-Cell:ifi110 EXX, Waveguide: R22)

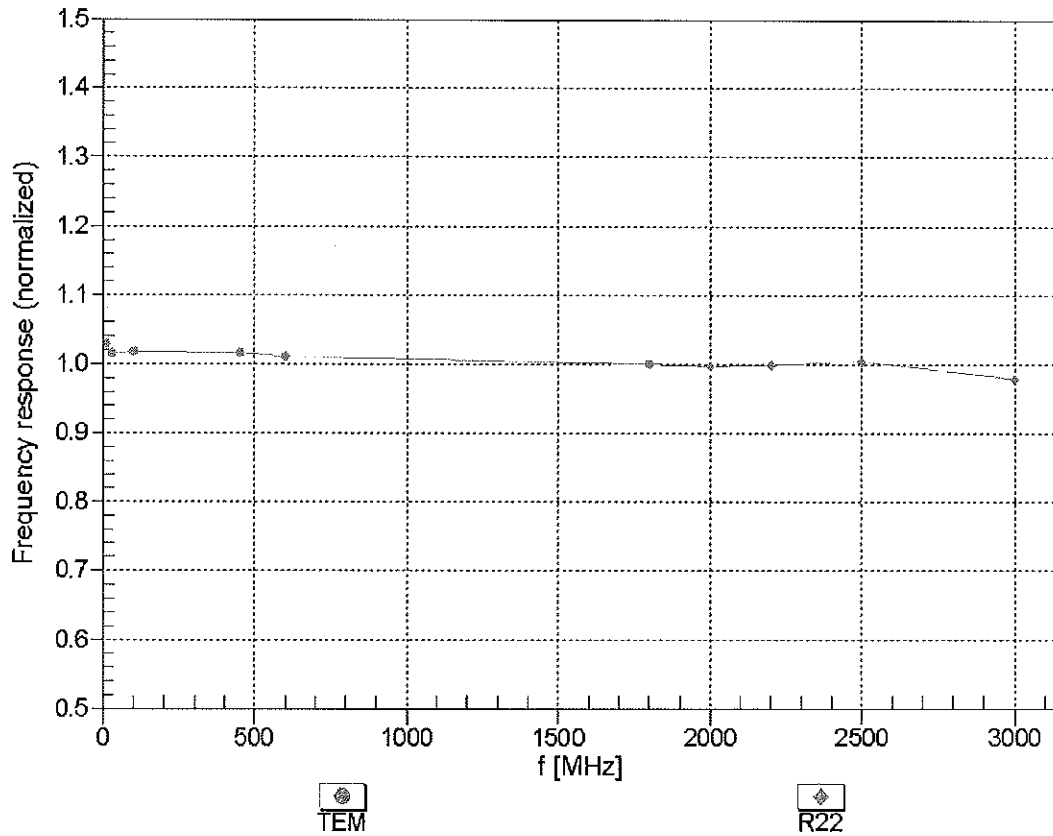

Uncertainty of Frequency Response of E-field:  $\pm 6.3\%$  (k=2)

### Receiving Pattern ( $\phi$ ), $\theta = 0^\circ$

f=600 MHz,TEM

f=1800 MHz,R22

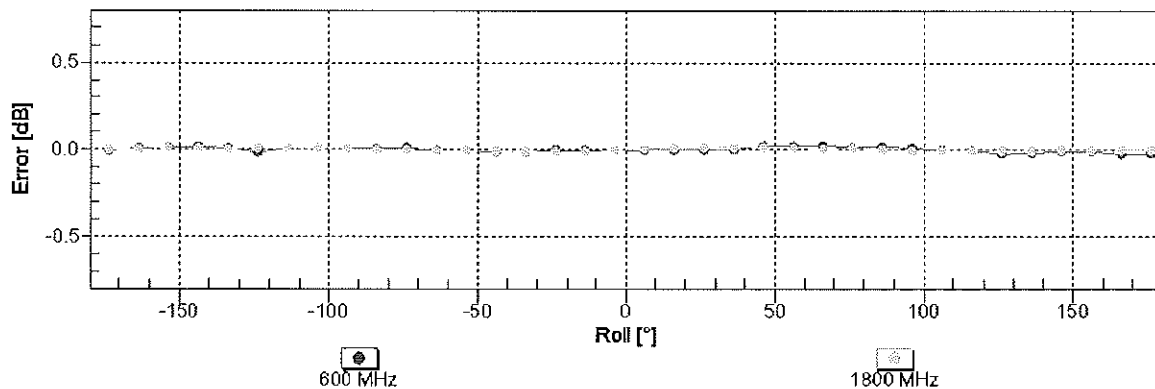
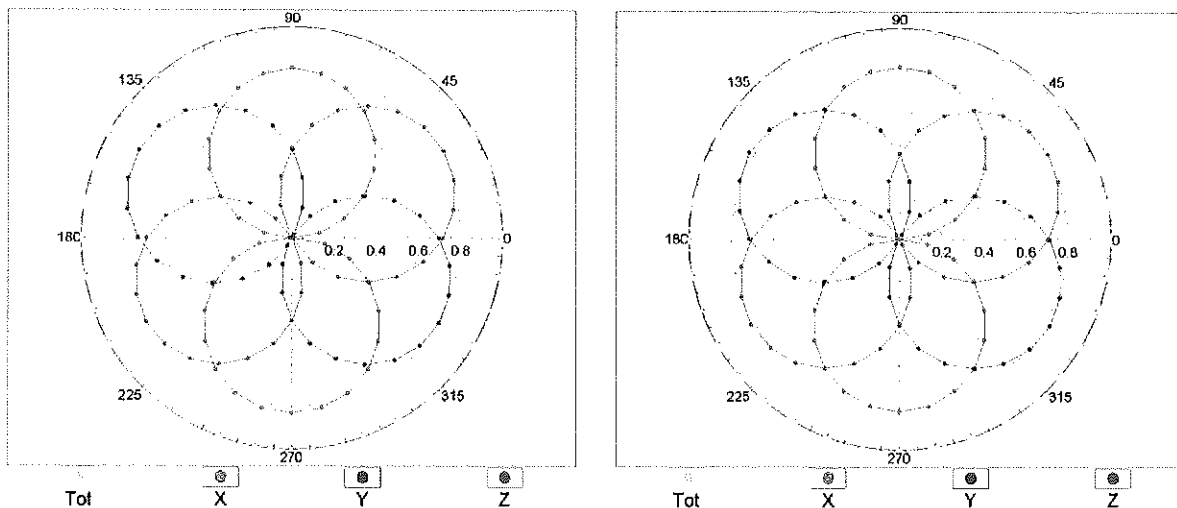

Uncertainty of Axial Isotropy Assessment:  $\pm 0.5\%$  ( $k=2$ )

### Dynamic Range $f(\text{SAR}_{\text{head}})$ (TEM cell , $f = 900 \text{ MHz}$ )

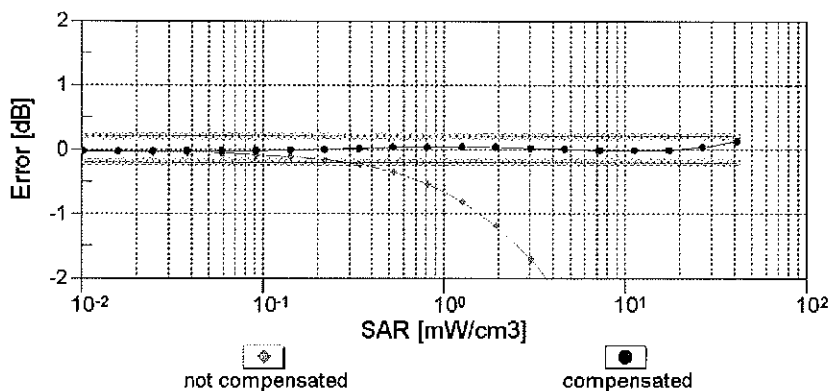
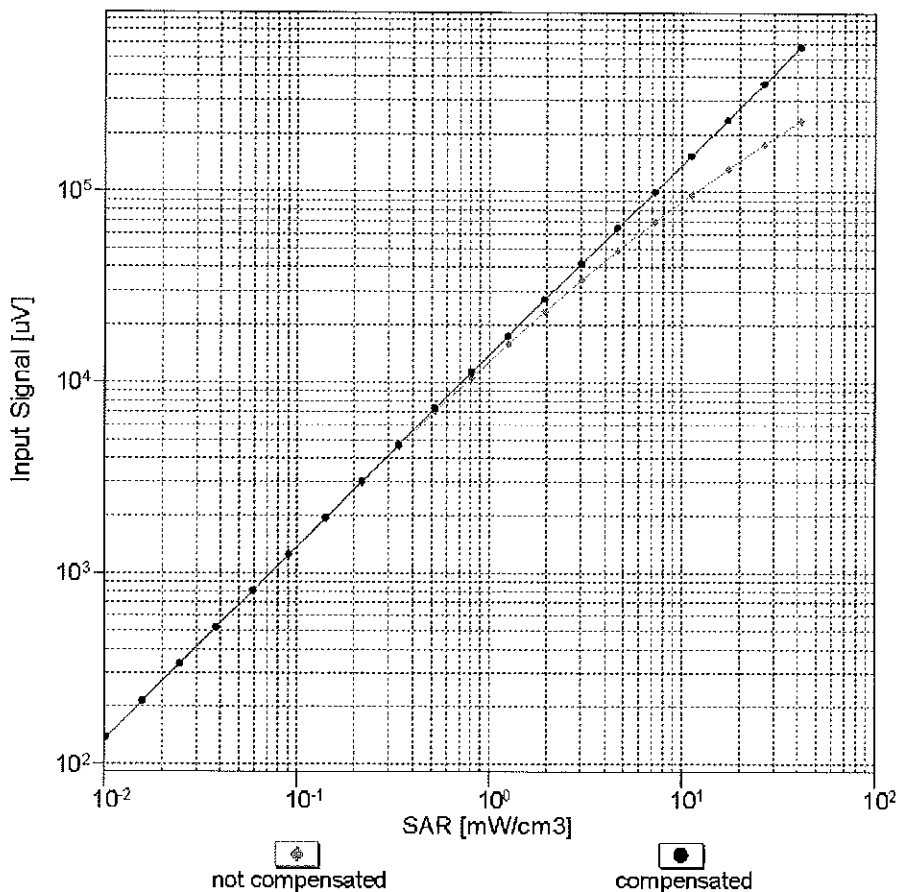

**Uncertainty of Linearity Assessment:  $\pm 0.6\%$  ( $k=2$ )**

# Conversion Factor Assessment

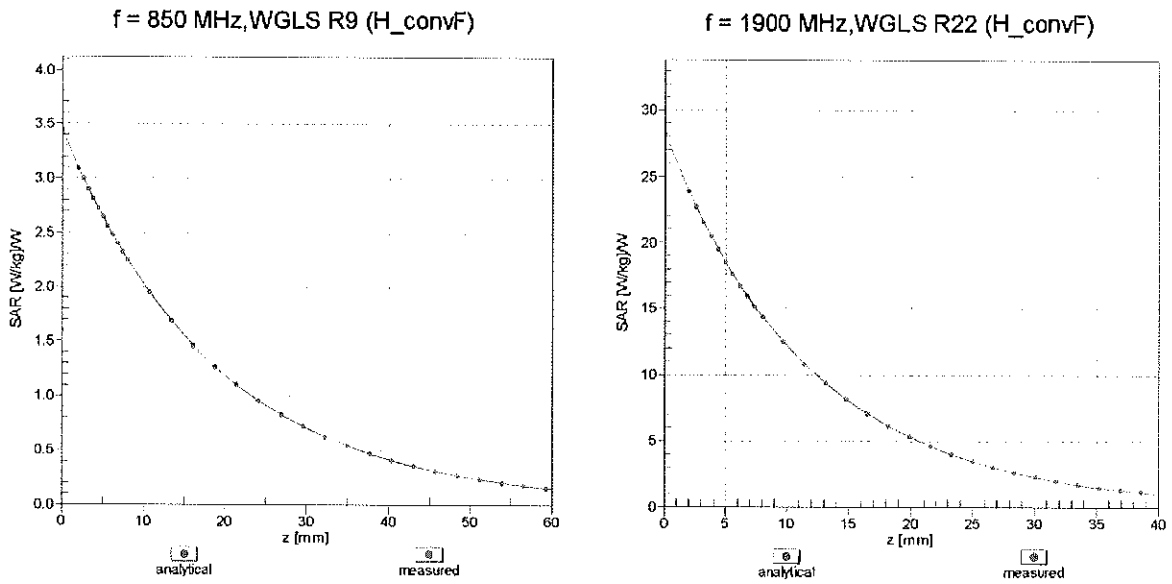

## Deviation from Isotropy in Liquid Error ( $\phi, \theta$ ), f = 900 MHz

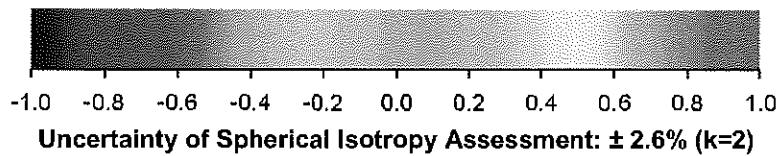
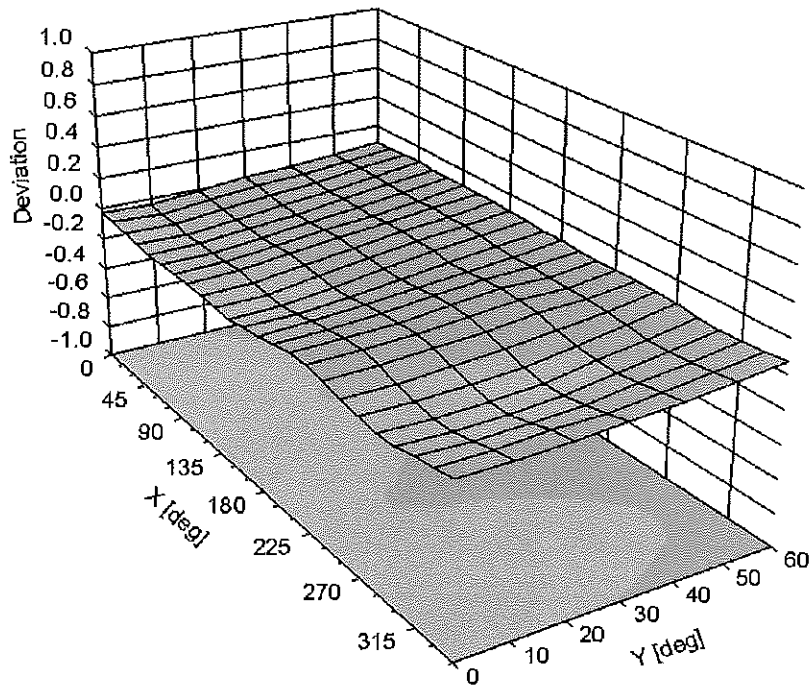

**DASY/EASY - Parameters of Probe: ES3DV3 - SN:3318****Other Probe Parameters**

Sensor Arrangement	Triangular
Connector Angle (°)	-103.8
Mechanical Surface Detection Mode	enabled
Optical Surface Detection Mode	disabled
Probe Overall Length	337 mm
Probe Body Diameter	10 mm
Tip Length	10 mm
Tip Diameter	4 mm
Probe Tip to Sensor X Calibration Point	2 mm
Probe Tip to Sensor Y Calibration Point	2 mm
Probe Tip to Sensor Z Calibration Point	2 mm
Recommended Measurement Distance from Surface	3 mm

## Additional Conversion Factors for Dosimetric E-Field Probe

Type:	<b>ES3DV3</b>
Serial Number:	<b>3318</b>
Place of Assessment:	<b>Zurich</b>
Date of Assessment:	<b>June 19, 2013</b>
Probe Calibration Date:	<b>April 29, 2013</b>

✓  
Kox  
6/25/13

Schmid & Partner Engineering AG hereby certifies that conversion factor(s) of this probe have been evaluated on the date indicated above. The assessment was performed using the FDTD numerical code SEMCAD of Schmid & Partner Engineering AG. The evaluation is coupled with measured conversion factors (probe calibration date indicated above). The uncertainty of the numerical assessment is based on the extrapolation from measured value at 835 MHz or at 1900 MHz.

Assessed by: 

## Dosimetric E-Field Probe ES3DV3 SN:3318

Conversion factor ( $\pm$  standard deviation)

1750  $\pm$  50 MHz      *ConvF*      5.59  $\pm$  7%

$\epsilon_r = 40.1 \pm 5\%$   
 $\sigma = 1.37 \pm 5\%$  mho/m  
 (head tissue)

1750  $\pm$  50 MHz      *ConvF*      5.22  $\pm$  7%

$\epsilon_r = 53.4 \pm 5\%$   
 $\sigma = 1.49 \pm 5\%$  mho/m  
 (body tissue)

### Important Note:

For numerically assessed probe conversion factors, parameters Alpha and Delta in the DASY software must have the following entries: Alpha = 0 and Delta = 1.

**Please see also DASY Manual.**



Accredited by the Swiss Accreditation Service (SAS)  
The Swiss Accreditation Service is one of the signatories to the EA  
Multilateral Agreement for the recognition of calibration certificates

Accreditation No.: **SCS 108**

Client **PC Test**

Certificate No: **ES3-3209\_Mar13**

**CALIBRATION CERTIFICATE**

Object **ES3DV3 - SN:3209**

Calibration procedure(s) **QA CAL-01.v8, QA CAL-23.v4, QA CAL-25.v4  
Calibration procedure for dosimetric E-field probes**

Calibration date: **March 15, 2013**

This calibration certificate documents the traceability to national standards, which realize the physical units of measurements (SI).  
The measurements and the uncertainties with confidence probability are given on the following pages and are part of the certificate.

All calibrations have been conducted in the closed laboratory facility: environment temperature (22 ± 3)°C and humidity < 70%.

*✓ KOK 3/22/13*

Calibration Equipment used (M&TE critical for calibration)

Primary Standards	ID	Cal Date (Certificate No.)	Scheduled Calibration
Power meter E4419B	GB41293874	29-Mar-12 (No. 217-01508)	Apr-13
Power sensor E4412A	MY41498087	29-Mar-12 (No. 217-01508)	Apr-13
Reference 3 dB Attenuator	SN: S5054 (3c)	27-Mar-12 (No. 217-01531)	Apr-13
Reference 20 dB Attenuator	SN: S5086 (20b)	27-Mar-12 (No. 217-01529)	Apr-13
Reference 30 dB Attenuator	SN: S5129 (30b)	27-Mar-12 (No. 217-01532)	Apr-13
Reference Probe ES3DV2	SN: 3013	28-Dec-12 (No. ES3-3013_Dec12)	Dec-13
DAE4	SN: 660	31-Jan-13 (No. DAE4-660_Jan13)	Jan-14
Secondary Standards	ID	Check Date (in house)	Scheduled Check
RF generator HP 8648C	US3642U01700	4-Aug-99 (in house check Apr-11)	In house check: Apr-13
Network Analyzer HP 8753E	US37390585	18-Oct-01 (in house check Oct-12)	In house check: Oct-13

	Name	Function	Signature
Calibrated by:	Israe El-Naouq	Laboratory Technician	<i>Israe El-Naouq</i>
Approved by:	Katja Pokovic	Technical Manager	<i>Katja Pokovic</i>

Issued: March 15, 2013

This calibration certificate shall not be reproduced except in full without written approval of the laboratory.

80242



Accredited by the Swiss Accreditation Service (SAS)

Accreditation No.: **SCS 108**

The Swiss Accreditation Service is one of the signatories to the EA  
 Multilateral Agreement for the recognition of calibration certificates

### Glossary:

TSL	tissue simulating liquid
NORM <sub>x,y,z</sub>	sensitivity in free space
ConvF	sensitivity in TSL / NORM <sub>x,y,z</sub>
DCP	diode compression point
CF	crest factor (1/duty_cycle) of the RF signal
A, B, C, D	modulation dependent linearization parameters
Polarization $\varphi$	$\varphi$ rotation around probe axis
Polarization $\vartheta$	$\vartheta$ rotation around an axis that is in the plane normal to probe axis (at measurement center), i.e., $\vartheta = 0$ is normal to probe axis

### Calibration is Performed According to the Following Standards:

- IEEE Std 1528-2003, "IEEE Recommended Practice for Determining the Peak Spatial-Averaged Specific Absorption Rate (SAR) in the Human Head from Wireless Communications Devices: Measurement Techniques", December 2003
- IEC 62209-1, "Procedure to measure the Specific Absorption Rate (SAR) for hand-held devices used in close proximity to the ear (frequency range of 300 MHz to 3 GHz)", February 2005

### Methods Applied and Interpretation of Parameters:

- NORM<sub>x,y,z</sub>**: Assessed for E-field polarization  $\vartheta = 0$  ( $f \leq 900$  MHz in TEM-cell;  $f > 1800$  MHz: R22 waveguide). NORM<sub>x,y,z</sub> are only intermediate values, i.e., the uncertainties of NORM<sub>x,y,z</sub> does not affect the E<sup>2</sup>-field uncertainty inside TSL (see below ConvF).
- NORM(f)<sub>x,y,z</sub>** = NORM<sub>x,y,z</sub> \* frequency\_response (see Frequency Response Chart). This linearization is implemented in DASY4 software versions later than 4.2. The uncertainty of the frequency response is included in the stated uncertainty of ConvF.
- DCP<sub>x,y,z</sub>**: DCP are numerical linearization parameters assessed based on the data of power sweep with CW signal (no uncertainty required). DCP does not depend on frequency nor media.
- PAR**: PAR is the Peak to Average Ratio that is not calibrated but determined based on the signal characteristics
- A<sub>x,y,z</sub>; B<sub>x,y,z</sub>; C<sub>x,y,z</sub>; D<sub>x,y,z</sub>; VR<sub>x,y,z</sub>; A, B, C, D** are numerical linearization parameters assessed based on the data of power sweep for specific modulation signal. The parameters do not depend on frequency nor media. VR is the maximum calibration range expressed in RMS voltage across the diode.
- ConvF and Boundary Effect Parameters**: Assessed in flat phantom using E-field (or Temperature Transfer Standard for  $f \leq 800$  MHz) and inside waveguide using analytical field distributions based on power measurements for  $f > 800$  MHz. The same setups are used for assessment of the parameters applied for boundary compensation (alpha, depth) of which typical uncertainty values are given. These parameters are used in DASY4 software to improve probe accuracy close to the boundary. The sensitivity in TSL corresponds to NORM<sub>x,y,z</sub> \* ConvF whereby the uncertainty corresponds to that given for ConvF. A frequency dependent ConvF is used in DASY version 4.4 and higher which allows extending the validity from  $\pm 50$  MHz to  $\pm 100$  MHz.
- Spherical isotropy (3D deviation from isotropy)**: in a field of low gradients realized using a flat phantom exposed by a patch antenna.
- Sensor Offset**: The sensor offset corresponds to the offset of virtual measurement center from the probe tip (on probe axis). No tolerance required.

# Probe ES3DV3

## SN:3209

Manufactured: October 14, 2008  
Calibrated: March 15, 2013

Calibrated for DASY/EASY Systems  
(Note: non-compatible with DASY2 system!)

## DASY/EASY - Parameters of Probe: ES3DV3 - SN:3209

### Basic Calibration Parameters

	Sensor X	Sensor Y	Sensor Z	Unc (k=2)
Norm ( $\mu\text{V}/(\text{V}/\text{m})^2$ ) <sup>A</sup>	1.35	1.33	1.14	$\pm 10.1 \%$
DCP (mV) <sup>B</sup>	99.2	97.8	98.3	

### Modulation Calibration Parameters

UID	Communication System Name		A dB	B dB $\sqrt{\mu\text{V}}$	C	D dB	VR mV	Unc <sup>E</sup> (k=2)
0	CW	X	0.0	0.0	1.0	0.00	163.6	$\pm 3.5 \%$
		Y	0.0	0.0	1.0		170.3	
		Z	0.0	0.0	1.0		158.7	

The reported uncertainty of measurement is stated as the standard uncertainty of measurement multiplied by the coverage factor  $k=2$ , which for a normal distribution corresponds to a coverage probability of approximately 95%.

<sup>A</sup> The uncertainties of NormX,Y,Z do not affect the  $E^2$ -field uncertainty inside TSL (see Pages 5 and 6).

<sup>B</sup> Numerical linearization parameter: uncertainty not required.

<sup>E</sup> Uncertainty is determined using the max. deviation from linear response applying rectangular distribution and is expressed for the square of the field value.

## DASY/EASY - Parameters of Probe: ES3DV3 - SN:3209

### Calibration Parameter Determined in Head Tissue Simulating Media

f (MHz) <sup>C</sup>	Relative Permittivity <sup>F</sup>	Conductivity (S/m) <sup>F</sup>	ConvF X	ConvF Y	ConvF Z	Alpha	Depth (mm)	Unct. (k=2)
750	41.9	0.89	6.74	6.74	6.74	0.76	1.18	± 12.0 %
835	41.5	0.90	6.46	6.46	6.46	0.31	1.81	± 12.0 %
1750	40.1	1.37	5.39	5.39	5.39	0.80	1.21	± 12.0 %
1900	40.0	1.40	5.21	5.21	5.21	0.78	1.26	± 12.0 %
2450	39.2	1.80	4.57	4.57	4.57	0.65	1.43	± 12.0 %
2600	39.0	1.96	4.43	4.43	4.43	0.75	1.36	± 12.0 %

<sup>C</sup> Frequency validity of ± 100 MHz only applies for DASY v4.4 and higher (see Page 2), else it is restricted to ± 50 MHz. The uncertainty is the RSS of the ConvF uncertainty at calibration frequency and the uncertainty for the indicated frequency band.

<sup>F</sup> At frequencies below 3 GHz, the validity of tissue parameters ( $\epsilon$  and  $\sigma$ ) can be relaxed to ± 10% if liquid compensation formula is applied to measured SAR values. At frequencies above 3 GHz, the validity of tissue parameters ( $\epsilon$  and  $\sigma$ ) is restricted to ± 5%. The uncertainty is the RSS of the ConvF uncertainty for indicated target tissue parameters.

## DASY/EASY - Parameters of Probe: ES3DV3 - SN:3209

### Calibration Parameter Determined in Body Tissue Simulating Media

f (MHz) <sup>C</sup>	Relative Permittivity <sup>F</sup>	Conductivity (S/m) <sup>F</sup>	ConvF X	ConvF Y	ConvF Z	Alpha	Depth (mm)	Unct. (k=2)
750	55.5	0.96	6.38	6.38	6.38	0.80	1.16	± 12.0 %
835	55.2	0.97	6.28	6.28	6.28	0.52	1.45	± 12.0 %
1750	53.4	1.49	5.03	5.03	5.03	0.58	1.45	± 12.0 %
1900	53.3	1.52	4.77	4.77	4.77	0.70	1.36	± 12.0 %
2450	52.7	1.95	4.34	4.34	4.34	0.80	1.15	± 12.0 %
2600	52.5	2.16	4.11	4.11	4.11	0.80	1.00	± 12.0 %

<sup>C</sup> Frequency validity of ± 100 MHz only applies for DASY v4.4 and higher (see Page 2), else it is restricted to ± 50 MHz. The uncertainty is the RSS of the ConvF uncertainty at calibration frequency and the uncertainty for the indicated frequency band.

<sup>F</sup> At frequencies below 3 GHz, the validity of tissue parameters ( $\epsilon$  and  $\sigma$ ) can be relaxed to ± 10% if liquid compensation formula is applied to measured SAR values. At frequencies above 3 GHz, the validity of tissue parameters ( $\epsilon$  and  $\sigma$ ) is restricted to ± 5%. The uncertainty is the RSS of the ConvF uncertainty for indicated target tissue parameters.

# Frequency Response of E-Field (TEM-Cell:ifi110 EXX, Waveguide: R22)

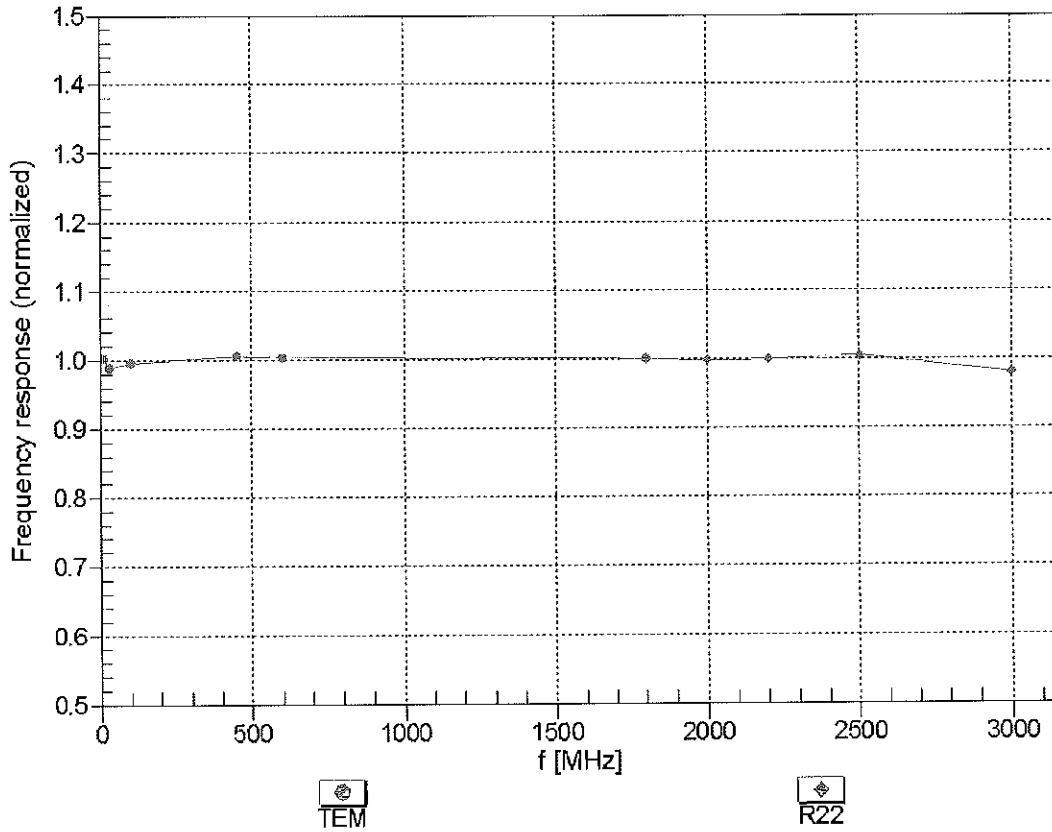

Uncertainty of Frequency Response of E-field:  $\pm 6.3\%$  (k=2)

### Receiving Pattern ( $\phi$ ), $\theta = 0^\circ$

f=600 MHz,TEM

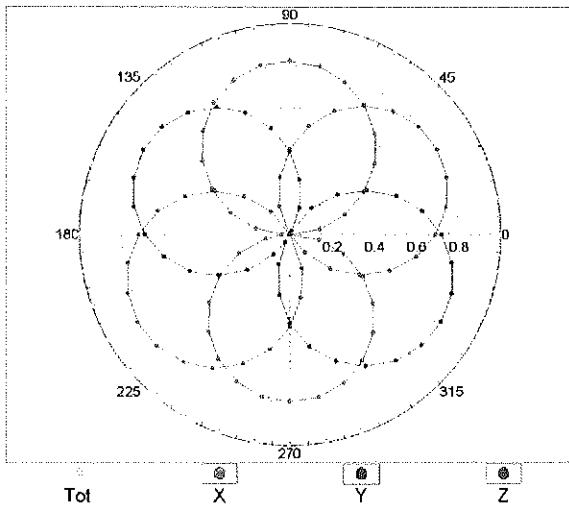

f=1800 MHz,R22

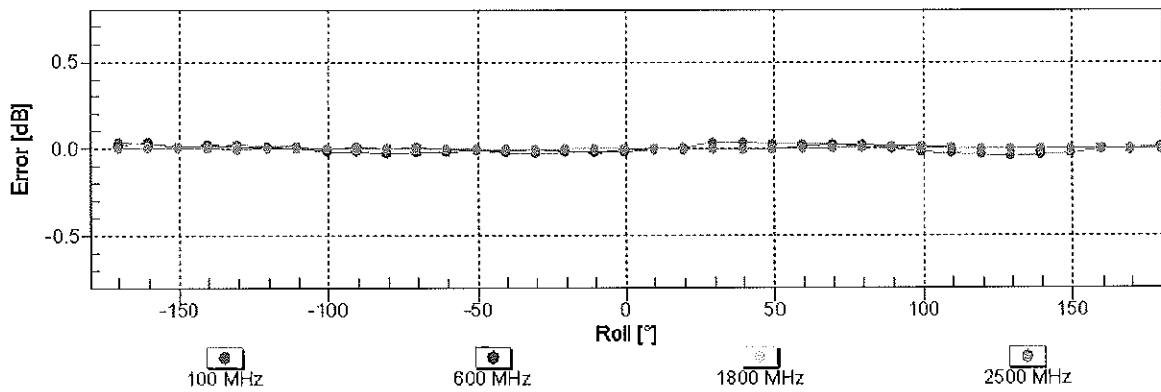
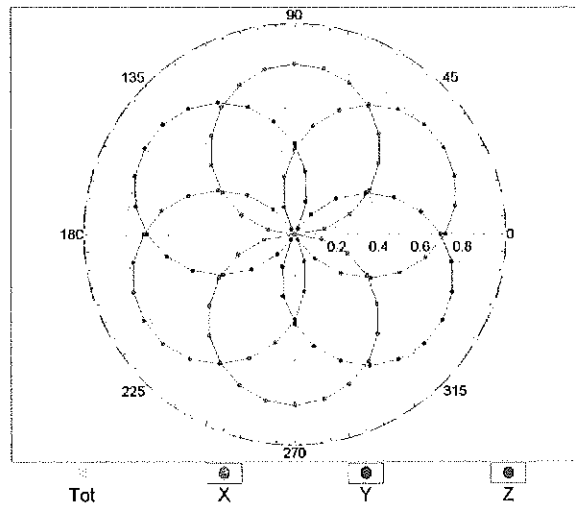

Uncertainty of Axial Isotropy Assessment:  $\pm 0.5\%$  (k=2)

### Dynamic Range $f(SAR_{head})$ (TEM cell , $f = 900$ MHz)

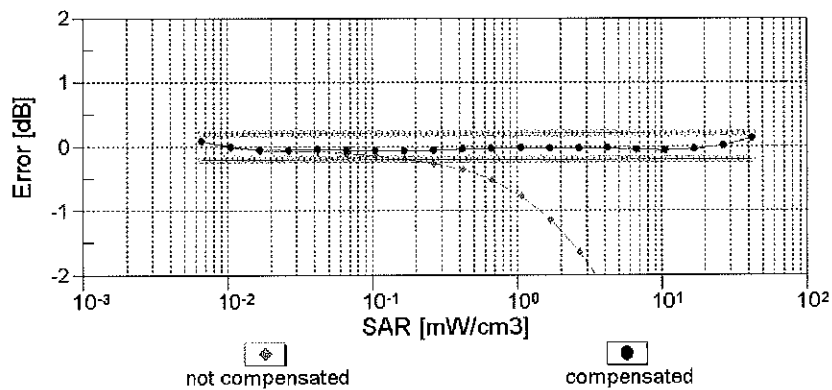
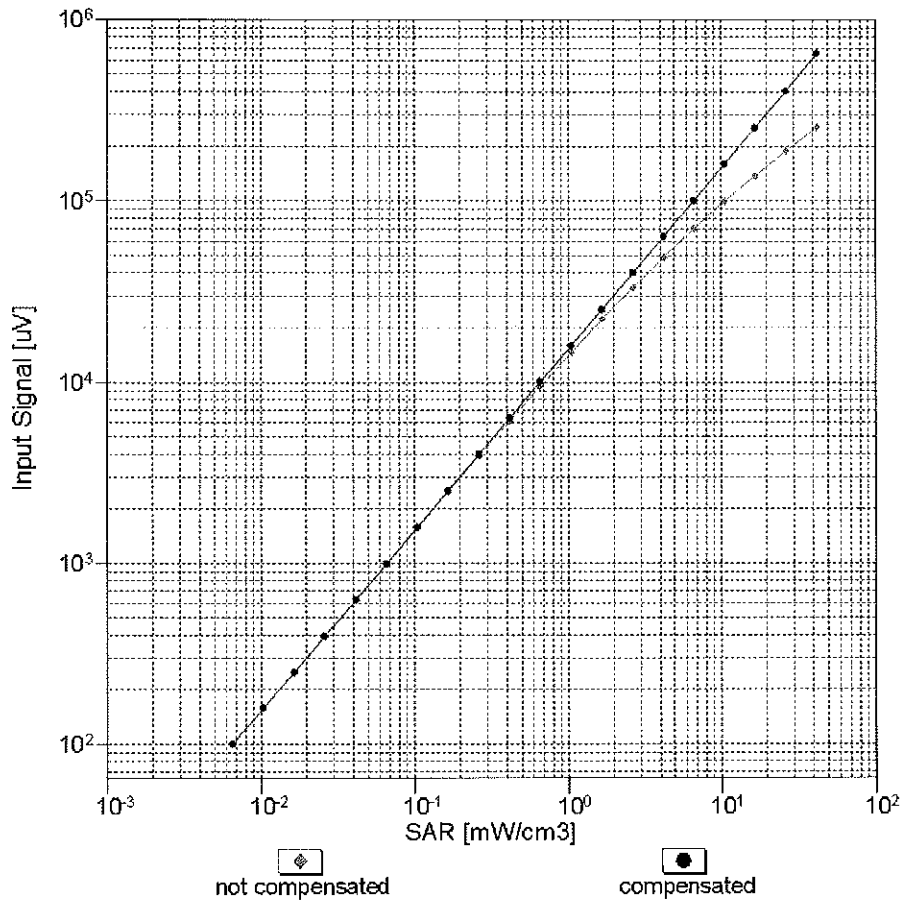

Uncertainty of Linearity Assessment:  $\pm 0.6\%$  ( $k=2$ )

# Conversion Factor Assessment

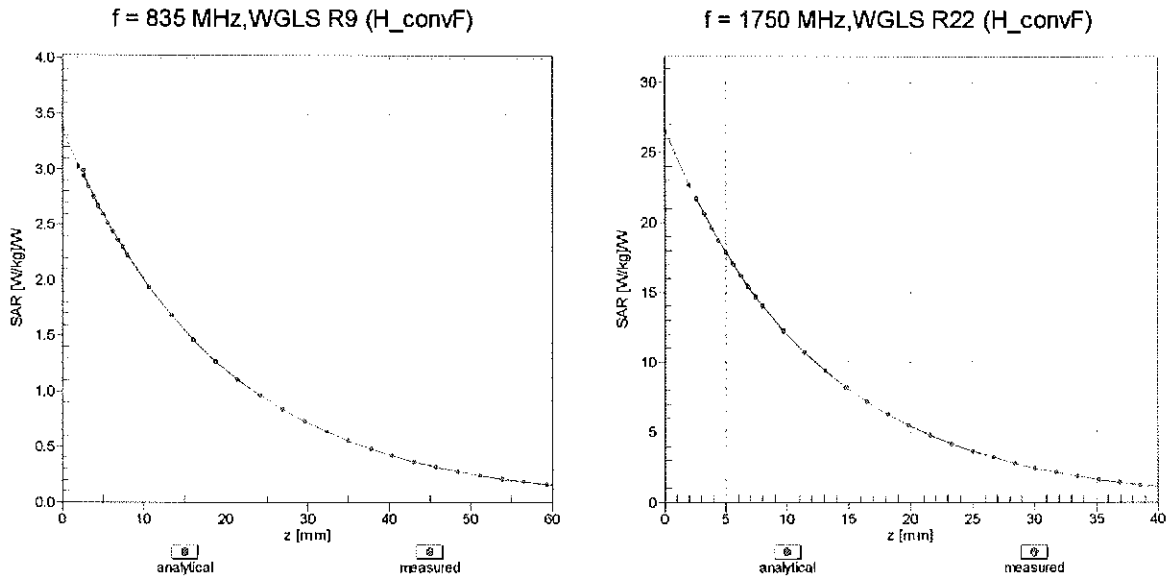

## Deviation from Isotropy in Liquid Error ( $\phi, \theta$ ), f = 900 MHz

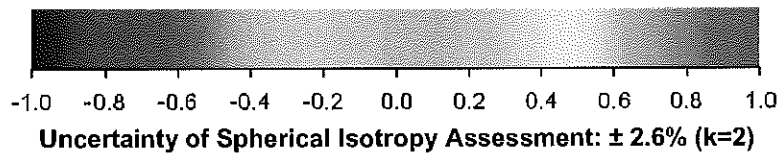
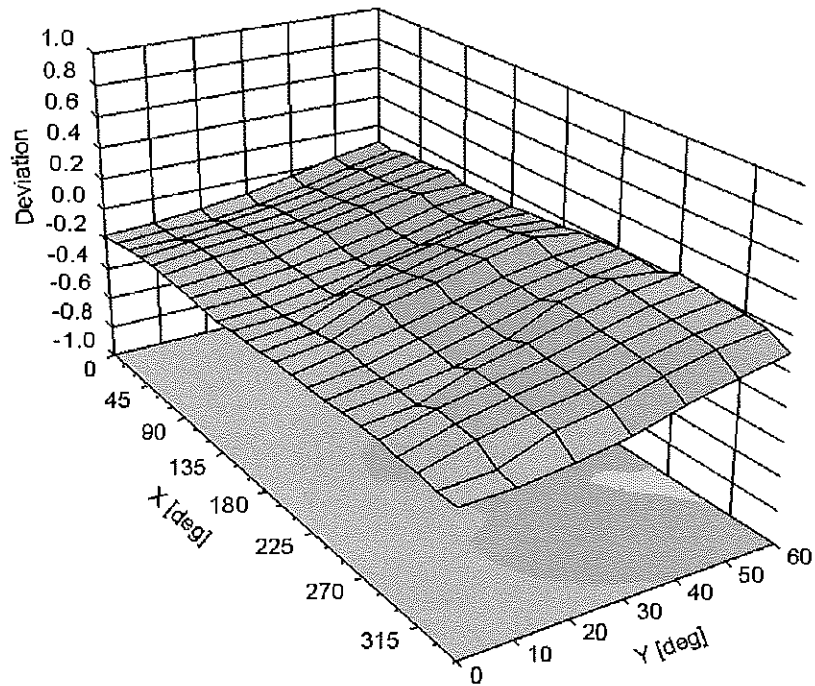

## DASY/EASY - Parameters of Probe: ES3DV3 - SN:3209

### Other Probe Parameters

Sensor Arrangement	Triangular
Connector Angle (°)	-40.6
Mechanical Surface Detection Mode	enabled
Optical Surface Detection Mode	disabled
Probe Overall Length	337 mm
Probe Body Diameter	10 mm
Tip Length	10 mm
Tip Diameter	4 mm
Probe Tip to Sensor X Calibration Point	2 mm
Probe Tip to Sensor Y Calibration Point	2 mm
Probe Tip to Sensor Z Calibration Point	2 mm
Recommended Measurement Distance from Surface	3 mm



Accredited by the Swiss Accreditation Service (SAS)  
The Swiss Accreditation Service is one of the signatories to the EA  
Multilateral Agreement for the recognition of calibration certificates

Accreditation No.: **SCS 108**

Client **PC Test**

Certificate No: **ES3-3258\_Feb14**

**CALIBRATION CERTIFICATE**

Object **ES3DV3 - SN:3258**

Calibration procedure(s) **QA CAL-01.v9, QA CAL-23.v5, QA CAL-25.v6  
Calibration procedure for dosimetric E-field probes** *CCV  
3/16/14*

Calibration date: **February 25, 2014**

This calibration certificate documents the traceability to national standards, which realize the physical units of measurements (SI).  
The measurements and the uncertainties with confidence probability are given on the following pages and are part of the certificate.

All calibrations have been conducted in the closed laboratory facility: environment temperature (22 ± 3)°C and humidity < 70%.

Calibration Equipment used (M&TE critical for calibration)

Primary Standards	ID	Cal Date (Certificate No.)	Scheduled Calibration
Power meter E4419B	GB41293874	04-Apr-13 (No. 217-01733)	Apr-14
Power sensor E4412A	MY41498087	04-Apr-13 (No. 217-01733)	Apr-14
Reference 3 dB Attenuator	SN: S5054 (3c)	04-Apr-13 (No. 217-01737)	Apr-14
Reference 20 dB Attenuator	SN: S5277 (20x)	04-Apr-13 (No. 217-01735)	Apr-14
Reference 30 dB Attenuator	SN: S5129 (30b)	04-Apr-13 (No. 217-01738)	Apr-14
Reference Probe ES3DV2	SN: 3013	30-Dec-13 (No. ES3-3013_Dec13)	Dec-14
DAE4	SN: 660	13-Dec-13 (No. DAE4-660_Dec13)	Dec-14
Secondary Standards	ID	Check Date (in house)	Scheduled Check
RF generator HP 8648C	US3642U01700	4-Aug-99 (in house check Apr-13)	In house check: Apr-16
Network Analyzer HP 8753E	US37390585	18-Oct-01 (in house check Oct-13)	In house check: Oct-14

Calibrated by:	Name <b>Israe El-Naouq</b>	Function <b>Laboratory Technician</b>	Signature <i>Israe El-Naouq</i>
Approved by:	<b>Katja Pokovic</b>	<b>Technical Manager</b>	<i>Katja Pokovic</i>

Issued: February 27, 2014

This calibration certificate shall not be reproduced except in full without written approval of the laboratory.

*PCT# 80615*



Accredited by the Swiss Accreditation Service (SAS)

Accreditation No.: **SCS 108**

The Swiss Accreditation Service is one of the signatories to the EA Multilateral Agreement for the recognition of calibration certificates

### Glossary:

TSL	tissue simulating liquid
NORM <sub>x,y,z</sub>	sensitivity in free space
ConvF	sensitivity in TSL / NORM <sub>x,y,z</sub>
DCP	diode compression point
CF	crest factor (1/duty_cycle) of the RF signal
A, B, C, D	modulation dependent linearization parameters
Polarization $\varphi$	$\varphi$ rotation around probe axis
Polarization $\vartheta$	$\vartheta$ rotation around an axis that is in the plane normal to probe axis (at measurement center), i.e., $\vartheta = 0$ is normal to probe axis
Connector Angle	information used in DASY system to align probe sensor X to the robot coordinate system

### Calibration is Performed According to the Following Standards:

- IEEE Std 1528-2013, "IEEE Recommended Practice for Determining the Peak Spatial-Averaged Specific Absorption Rate (SAR) in the Human Head from Wireless Communications Devices: Measurement Techniques", June 2013
- IEC 62209-1, "Procedure to measure the Specific Absorption Rate (SAR) for hand-held devices used in close proximity to the ear (frequency range of 300 MHz to 3 GHz)", February 2005

### Methods Applied and Interpretation of Parameters:

- NORM<sub>x,y,z</sub>:** Assessed for E-field polarization  $\vartheta = 0$  ( $f \leq 900$  MHz in TEM-cell;  $f > 1800$  MHz: R22 waveguide). NORM<sub>x,y,z</sub> are only intermediate values, i.e., the uncertainties of NORM<sub>x,y,z</sub> does not affect the E<sup>2</sup>-field uncertainty inside TSL (see below ConvF).
- NORM(f)<sub>x,y,z</sub> = NORM<sub>x,y,z</sub> \* frequency\_response** (see Frequency Response Chart). This linearization is implemented in DASY4 software versions later than 4.2. The uncertainty of the frequency response is included in the stated uncertainty of ConvF.
- DCP<sub>x,y,z</sub>:** DCP are numerical linearization parameters assessed based on the data of power sweep with CW signal (no uncertainty required). DCP does not depend on frequency nor media.
- PAR:** PAR is the Peak to Average Ratio that is not calibrated but determined based on the signal characteristics
- A<sub>x,y,z</sub>; B<sub>x,y,z</sub>; C<sub>x,y,z</sub>; D<sub>x,y,z</sub>; VR<sub>x,y,z</sub>:** A, B, C, D are numerical linearization parameters assessed based on the data of power sweep for specific modulation signal. The parameters do not depend on frequency nor media. VR is the maximum calibration range expressed in RMS voltage across the diode.
- ConvF and Boundary Effect Parameters:** Assessed in flat phantom using E-field (or Temperature Transfer Standard for  $f \leq 800$  MHz) and inside waveguide using analytical field distributions based on power measurements for  $f > 800$  MHz. The same setups are used for assessment of the parameters applied for boundary compensation (alpha, depth) of which typical uncertainty values are given. These parameters are used in DASY4 software to improve probe accuracy close to the boundary. The sensitivity in TSL corresponds to NORM<sub>x,y,z</sub> \* ConvF whereby the uncertainty corresponds to that given for ConvF. A frequency dependent ConvF is used in DASY version 4.4 and higher which allows extending the validity from  $\pm 50$  MHz to  $\pm 100$  MHz.
- Spherical isotropy (3D deviation from isotropy):** in a field of low gradients realized using a flat phantom exposed by a patch antenna.
- Sensor Offset:** The sensor offset corresponds to the offset of virtual measurement center from the probe tip (on probe axis). No tolerance required.
- Connector Angle:** The angle is assessed using the information gained by determining the NORM<sub>x</sub> (no uncertainty required).

# Probe ES3DV3

## SN:3258

Manufactured: January 25, 2010  
Calibrated: February 25, 2014

Calibrated for DASY/EASY Systems  
(Note: non-compatible with DASY2 system!)

# DASY/EASY - Parameters of Probe: ES3DV3 - SN:3258

## Basic Calibration Parameters

	Sensor X	Sensor Y	Sensor Z	Unc (k=2)
Norm ( $\mu V/(V/m)^2$ ) <sup>A</sup>	1.29	1.19	1.23	± 10.1 %
DCP (mV) <sup>B</sup>	104.5	107.0	103.0	

## Modulation Calibration Parameters

UID	Communication System Name		A dB	B dB√μV	C	D dB	VR mV	Unc <sup>E</sup> (k=2)
0	CW	X	0.0	0.0	1.0	0.00	222.4	±3.8 %
		Y	0.0	0.0	1.0		202.2	
		Z	0.0	0.0	1.0		207.1	
10010-CAA	SAR Validation (Square, 100ms, 10ms)	X	5.09	65.6	14.1	10.00	44.8	±1.9 %
		Y	1.68	57.4	9.3		40.7	
		Z	4.01	62.4	13.0		51.1	
10011-CAB	UMTS-FDD (WCDMA)	X	3.34	67.5	18.9	2.91	131.2	±0.5 %
		Y	3.43	67.9	18.7		137.1	
		Z	3.42	67.8	19.0		146.0	
10012-CAA	IEEE 802.11b WiFi 2.4 GHz (DSSS, 1 Mbps)	X	3.40	70.9	19.8	1.87	134.2	±0.7 %
		Y	3.19	70.2	19.2		137.9	
		Z	3.46	70.8	19.6		149.6	
10021-DAB	GSM-FDD (TDMA, GMSK)	X	30.24	99.7	28.7	9.39	131.2	±1.4 %
		Y	12.91	88.5	23.9		147.5	
		Z	30.37	99.5	28.9		128.0	
10023-DAB	GPRS-FDD (TDMA, GMSK, TN 0)	X	29.88	100.0	29.0	9.57	123.0	±1.9 %
		Y	16.02	92.5	25.4		140.7	
		Z	30.01	100.0	29.4		125.8	
10024-DAB	GPRS-FDD (TDMA, GMSK, TN 0-1)	X	44.57	99.7	25.9	6.56	119.6	±1.7 %
		Y	28.97	95.3	23.2		127.6	
		Z	43.72	99.8	26.3		120.1	
10027-DAB	GPRS-FDD (TDMA, GMSK, TN 0-1-2)	X	53.52	99.7	24.4	4.80	129.4	±2.2 %
		Y	54.55	99.9	22.9		143.3	
		Z	51.63	99.7	24.8		127.5	
10028-DAB	GPRS-FDD (TDMA, GMSK, TN 0-1-2-3)	X	58.93	99.8	23.4	3.55	133.4	±2.2 %
		Y	77.54	99.7	21.3		125.3	
		Z	56.64	99.8	23.8		130.8	
10032-CAA	IEEE 802.15.1 Bluetooth (GFSK, DH5)	X	47.03	99.5	21.3	1.16	136.3	±1.7 %
		Y	95.86	95.2	17.1		138.2	
		Z	39.68	100.0	22.2		132.3	
10039-CAB	CDMA2000 (1xRTT, RC1)	X	4.84	66.8	19.1	4.57	131.3	±0.9 %
		Y	4.75	67.0	18.9		135.2	
		Z	4.86	66.7	19.0		127.2	

10081-CAB	CDMA2000 (1xRTT, RC3)	X	4.06	66.8	19.0	3.97	148.4	±0.7 %
		Y	3.96	66.6	18.6		134.7	
		Z	4.13	66.9	19.1		143.4	
10098-CAB	UMTS-FDD (HSUPA, Subtest 2)	X	4.63	66.8	18.7	3.98	137.3	±0.7 %
		Y	4.75	67.5	18.8		148.4	
		Z	4.65	66.7	18.7		133.2	
10100-CAB	LTE-FDD (SC-FDMA, 100% RB, 20 MHz, QPSK)	X	6.66	68.5	20.3	5.67	144.0	±1.2 %
		Y	6.27	67.1	19.3		130.6	
		Z	6.62	68.2	20.1		140.5	
10108-CAB	LTE-FDD (SC-FDMA, 100% RB, 10 MHz, QPSK)	X	6.53	68.0	20.2	5.80	142.6	±1.4 %
		Y	6.17	66.8	19.3		129.2	
		Z	6.52	67.8	20.1		139.0	
10110-CAB	LTE-FDD (SC-FDMA, 100% RB, 5 MHz, QPSK)	X	6.19	67.3	19.9	5.75	137.9	±1.4 %
		Y	6.12	67.3	19.6		149.5	
		Z	6.19	67.1	19.8		136.1	
10114-CAA	IEEE 802.11n (HT Greenfield, 13.5 Mbps, BPSK)	X	10.49	69.5	21.7	8.10	132.4	±2.5 %
		Y	10.23	69.1	21.3		144.3	
		Z	10.45	69.3	21.6		129.5	
10117-CAA	IEEE 802.11n (HT Mixed, 13.5 Mbps, BPSK)	X	10.46	69.5	21.7	8.07	133.9	±2.5 %
		Y	10.26	69.2	21.3		147.4	
		Z	10.47	69.4	21.7		130.5	
10151-CAB	LTE-TDD (SC-FDMA, 50% RB, 20 MHz, QPSK)	X	11.61	77.4	26.8	9.28	118.8	±3.0 %
		Y	9.89	75.2	25.7		144.9	
		Z	12.01	77.8	26.9		119.6	
10154-CAB	LTE-FDD (SC-FDMA, 50% RB, 10 MHz, QPSK)	X	6.20	67.3	19.9	5.75	139.2	±1.2 %
		Y	5.86	66.2	19.0		128.5	
		Z	6.22	67.3	19.9		136.3	
10160-CAB	LTE-FDD (SC-FDMA, 50% RB, 15 MHz, QPSK)	X	6.63	67.8	20.1	5.82	144.1	±1.4 %
		Y	6.31	66.8	19.3		133.1	
		Z	6.66	67.7	20.0		140.9	
10169-CAB	LTE-FDD (SC-FDMA, 1 RB, 20 MHz, QPSK)	X	5.25	67.5	20.2	5.73	143.6	±1.2 %
		Y	4.92	66.7	19.5		131.0	
		Z	5.29	67.4	20.2		140.7	
10172-CAB	LTE-TDD (SC-FDMA, 1 RB, 20 MHz, QPSK)	X	13.49	87.5	31.6	9.21	139.0	±2.7 %
		Y	7.83	75.5	26.0		124.9	
		Z	13.47	86.5	31.1		137.8	
10175-CAB	LTE-FDD (SC-FDMA, 1 RB, 10 MHz, QPSK)	X	5.22	67.4	20.1	5.72	144.3	±1.4 %
		Y	5.08	67.5	19.9		147.9	
		Z	5.26	67.2	20.0		139.6	
10181-CAB	LTE-FDD (SC-FDMA, 1 RB, 15 MHz, QPSK)	X	5.24	67.5	20.1	5.72	144.5	±1.2 %
		Y	5.06	67.4	19.8		147.0	
		Z	5.29	67.3	20.1		139.2	

10193-CAA	IEEE 802.11n (HT Greenfield, 6.5 Mbps, BPSK)	X	10.12	69.1	21.6	8.09	128.8	±2.2 %
		Y	9.76	68.4	21.0		132.8	
		Z	10.08	68.9	21.5		123.4	
10196-CAA	IEEE 802.11n (HT Mixed, 6.5 Mbps, BPSK)	X	10.15	69.2	21.7	8.10	130.2	±2.2 %
		Y	9.77	68.5	21.0		134.1	
		Z	10.10	69.0	21.5		124.0	
10219-CAA	IEEE 802.11n (HT Mixed, 7.2 Mbps, BPSK)	X	10.02	69.0	21.5	8.03	128.7	±2.2 %
		Y	9.67	68.5	21.0		133.3	
		Z	10.02	68.9	21.5		123.9	
10222-CAA	IEEE 802.11n (HT Mixed, 15 Mbps, BPSK)	X	10.46	69.6	21.7	8.06	134.0	±2.2 %
		Y	10.09	68.8	21.1		139.7	
		Z	10.40	69.3	21.6		128.7	
10225-CAB	UMTS-FDD (HSPA+)	X	7.09	67.1	19.6	5.97	131.2	±1.4 %
		Y	6.98	67.2	19.4		138.0	
		Z	7.06	66.8	19.4		127.2	
10237-CAB	LTE-TDD (SC-FDMA, 1 RB, 10 MHz, QPSK)	X	13.63	87.8	31.7	9.21	141.6	±3.0 %
		Y	7.85	75.5	26.0		126.5	
		Z	13.99	87.7	31.6		141.4	
10252-CAB	LTE-TDD (SC-FDMA, 50% RB, 10 MHz, QPSK)	X	12.86	81.4	28.9	9.24	142.1	±3.0 %
		Y	8.91	73.4	24.8		129.9	
		Z	13.15	81.4	28.8		142.0	
10267-CAB	LTE-TDD (SC-FDMA, 100% RB, 10 MHz, QPSK)	X	11.63	77.5	26.8	9.30	118.7	±3.0 %
		Y	9.62	74.3	25.2		138.4	
		Z	11.96	77.7	26.9		119.3	
10274-CAB	UMTS-FDD (HSUPA, Subtest 5, 3GPP Rel8.10)	X	6.14	67.4	19.3	4.87	149.9	±0.9 %
		Y	5.90	66.9	18.7		132.8	
		Z	6.20	67.5	19.3		146.6	
10275-CAB	UMTS-FDD (HSUPA, Subtest 5, 3GPP Rel8.4)	X	4.45	66.9	18.9	3.96	130.1	±0.7 %
		Y	4.50	67.2	18.8		137.9	
		Z	4.64	67.6	19.3		149.2	
10291-AAB	CDMA2000, RC3, SO55, Full Rate	X	3.79	67.5	19.2	3.46	145.3	±0.7 %
		Y	3.74	67.5	18.9		128.2	
		Z	3.78	67.3	19.1		139.1	
10292-AAB	CDMA2000, RC3, SO32, Full Rate	X	3.77	67.8	19.3	3.39	147.0	±0.5 %
		Y	3.69	67.7	18.9		130.1	
		Z	3.73	67.3	19.0		141.3	
10297-AAA	LTE-FDD (SC-FDMA, 50% RB, 20 MHz, QPSK)	X	6.52	67.9	20.1	5.81	141.4	±1.4 %
		Y	6.41	67.6	19.7		147.4	
		Z	6.51	67.7	20.1		135.4	
10311-AAA	LTE-FDD (SC-FDMA, 100% RB, 15 MHz, QPSK)	X	7.17	68.7	20.7	6.06	147.7	±1.4 %
		Y	6.69	67.2	19.6		128.6	
		Z	7.12	68.4	20.5		142.0	

10315-AAA	IEEE 802.11b WiFi 2.4 GHz (DSSS, 1 Mbps, 96pc duty cycle)	X	3.04	70.0	19.6	1.71	129.8	±0.5 %
		Y	3.25	71.3	19.7		136.9	
		Z	3.09	69.9	19.5		148.7	
10403-AAB	CDMA2000 (1xEV-DO, Rev. 0)	X	4.73	67.3	18.6	3.76	135.7	±0.5 %
		Y	4.93	69.1	19.0		141.5	
		Z	4.73	67.1	18.4		132.7	
10404-AAB	CDMA2000 (1xEV-DO, Rev. A)	X	4.67	67.5	18.6	3.77	134.0	±0.5 %
		Y	4.92	69.4	19.1		139.8	
		Z	4.65	67.1	18.5		130.7	

The reported uncertainty of measurement is stated as the standard uncertainty of measurement multiplied by the coverage factor k=2, which for a normal distribution corresponds to a coverage probability of approximately 95%.

<sup>A</sup> The uncertainties of NormX,Y,Z do not affect the E<sup>2</sup>-field uncertainty inside TSL (see Pages 8 and 9).  
<sup>B</sup> Numerical linearization parameter: uncertainty not required.  
<sup>E</sup> Uncertainty is determined using the max. deviation from linear response applying rectangular distribution and is expressed for the square of the field value.

## DASY/EASY - Parameters of Probe: ES3DV3 - SN:3258

### Calibration Parameter Determined in Head Tissue Simulating Media

f (MHz) <sup>C</sup>	Relative Permittivity <sup>F</sup>	Conductivity (S/m) <sup>F</sup>	ConvF X	ConvF Y	ConvF Z	Alpha <sup>G</sup>	Depth <sup>G</sup> (mm)	Unct. (k=2)
750	41.9	0.89	6.53	6.53	6.53	0.40	1.60	± 12.0 %
835	41.5	0.90	6.27	6.27	6.27	0.80	1.17	± 12.0 %
1750	40.1	1.37	5.19	5.19	5.19	0.80	1.10	± 12.0 %
1900	40.0	1.40	5.04	5.04	5.04	0.68	1.27	± 12.0 %
2450	39.2	1.80	4.52	4.52	4.52	0.78	1.23	± 12.0 %
2600	39.0	1.96	4.34	4.34	4.34	0.76	1.33	± 12.0 %

<sup>C</sup> Frequency validity of ± 100 MHz only applies for DASY v4.4 and higher (see Page 2), else it is restricted to ± 50 MHz. The uncertainty is the RSS of the ConvF uncertainty at calibration frequency and the uncertainty for the indicated frequency band.

<sup>F</sup> At frequencies below 3 GHz, the validity of tissue parameters ( $\epsilon$  and  $\sigma$ ) can be relaxed to ± 10% if liquid compensation formula is applied to measured SAR values. At frequencies above 3 GHz, the validity of tissue parameters ( $\epsilon$  and  $\sigma$ ) is restricted to ± 5%. The uncertainty is the RSS of the ConvF uncertainty for indicated target tissue parameters.

<sup>G</sup> Alpha/Depth are determined during calibration. SPEAG warrants that the remaining deviation due to the boundary effect after compensation is always less than ± 1% for frequencies below 3 GHz and below ± 2% for frequencies between 3-6 GHz at any distance larger than half the probe tip diameter from the boundary.

## DASY/EASY - Parameters of Probe: ES3DV3 - SN:3258

### Calibration Parameter Determined in Body Tissue Simulating Media

f (MHz) <sup>c</sup>	Relative Permittivity <sup>F</sup>	Conductivity (S/m) <sup>F</sup>	ConvF X	ConvF Y	ConvF Z	Alpha <sup>G</sup>	Depth <sup>G</sup> (mm)	Unct. (k=2)
750	55.5	0.96	6.15	6.15	6.15	0.61	1.32	± 12.0 %
835	55.2	0.97	6.11	6.11	6.11	0.80	1.15	± 12.0 %
1750	53.4	1.49	4.83	4.83	4.83	0.47	1.74	± 12.0 %
1900	53.3	1.52	4.61	4.61	4.61	0.55	1.59	± 12.0 %
2450	52.7	1.95	4.14	4.14	4.14	0.80	1.11	± 12.0 %
2600	52.5	2.16	3.91	3.91	3.91	0.80	1.00	± 12.0 %

<sup>c</sup> Frequency validity of ± 100 MHz only applies for DASY v4.4 and higher (see Page 2), else it is restricted to ± 50 MHz. The uncertainty is the RSS of the ConvF uncertainty at calibration frequency and the uncertainty for the indicated frequency band.

<sup>F</sup> At frequencies below 3 GHz, the validity of tissue parameters ( $\epsilon$  and  $\sigma$ ) can be relaxed to ± 10% if liquid compensation formula is applied to measured SAR values. At frequencies above 3 GHz, the validity of tissue parameters ( $\epsilon$  and  $\sigma$ ) is restricted to ± 5%. The uncertainty is the RSS of the ConvF uncertainty for indicated target tissue parameters.

<sup>G</sup> Alpha/Depth are determined during calibration. SPEAG warrants that the remaining deviation due to the boundary effect after compensation is always less than ± 1% for frequencies below 3 GHz and below ± 2% for frequencies between 3-6 GHz at any distance larger than half the probe tip diameter from the boundary.

### Frequency Response of E-Field (TEM-Cell: ifi110 EXX, Waveguide: R22)

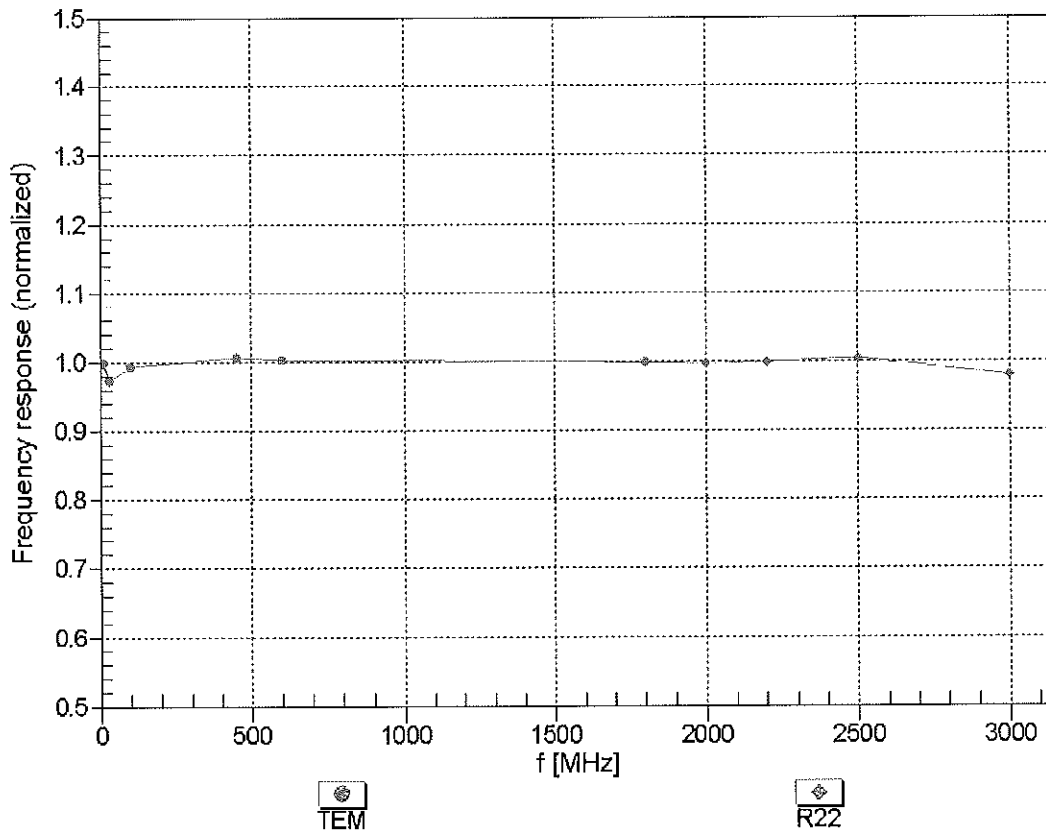

Uncertainty of Frequency Response of E-field:  $\pm 6.3\%$  (k=2)

### Receiving Pattern ( $\phi$ ), $\theta = 0^\circ$

f=600 MHz,TEM

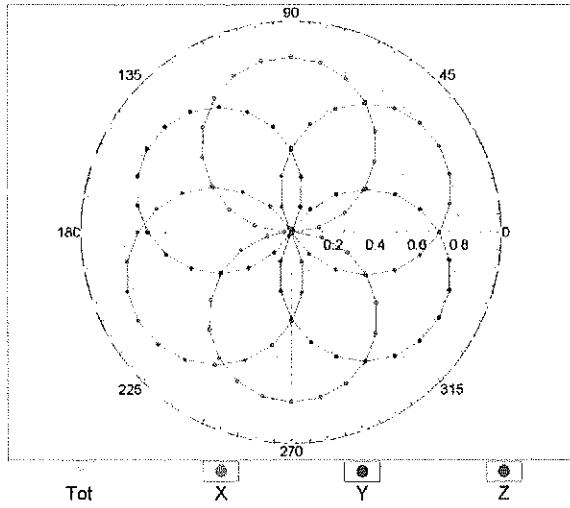

f=1800 MHz,R22

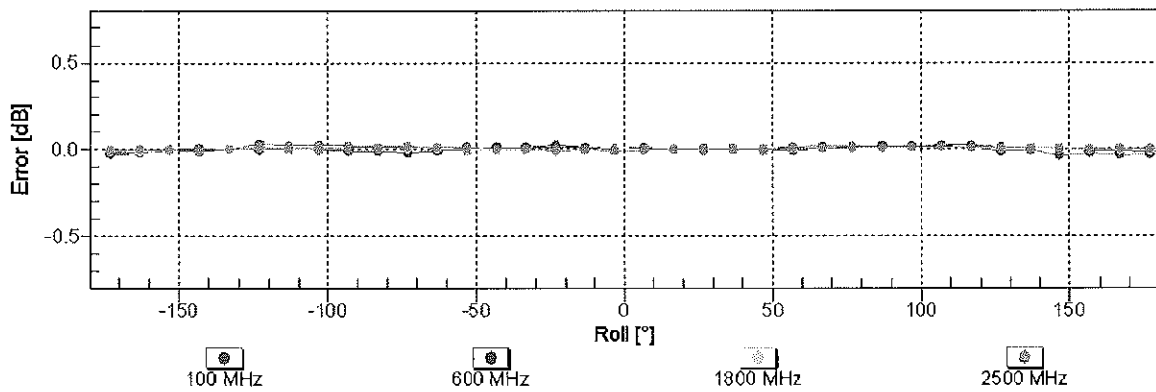
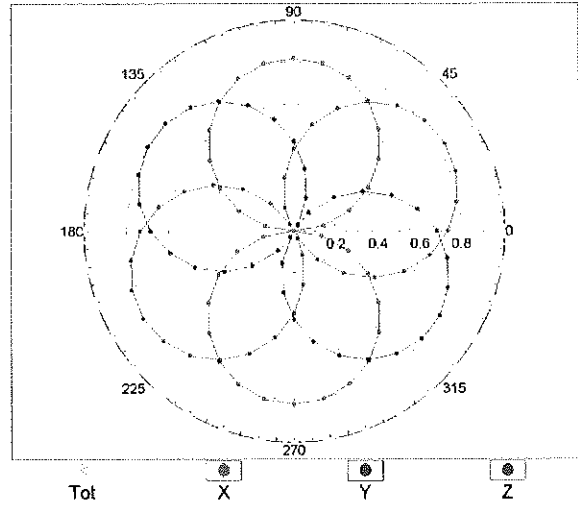

Uncertainty of Axial Isotropy Assessment:  $\pm 0.5\%$  ( $k=2$ )

### Dynamic Range f(SAR<sub>head</sub>) (TEM cell , f<sub>eval</sub>= 1900 MHz)

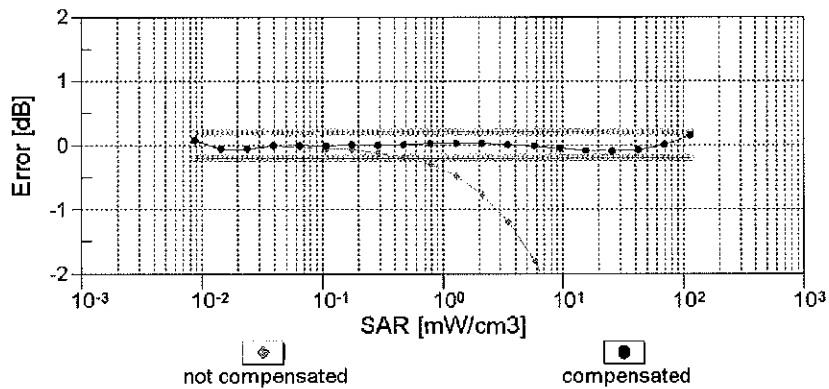
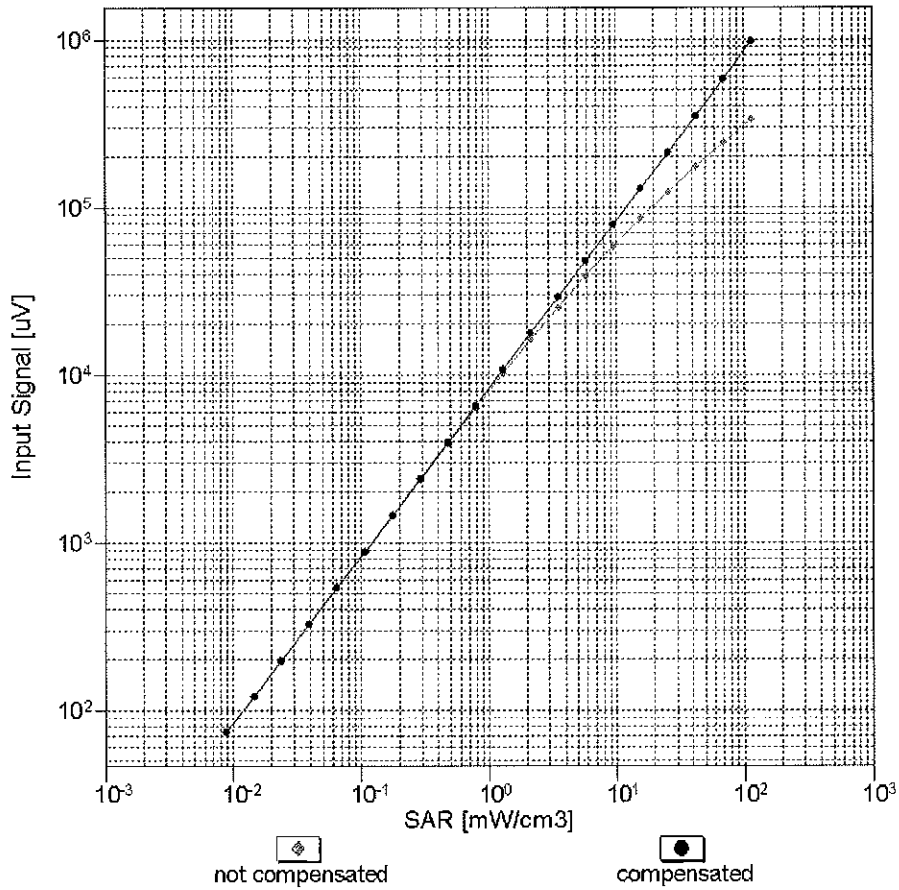

Uncertainty of Linearity Assessment: ± 0.6% (k=2)

# Conversion Factor Assessment

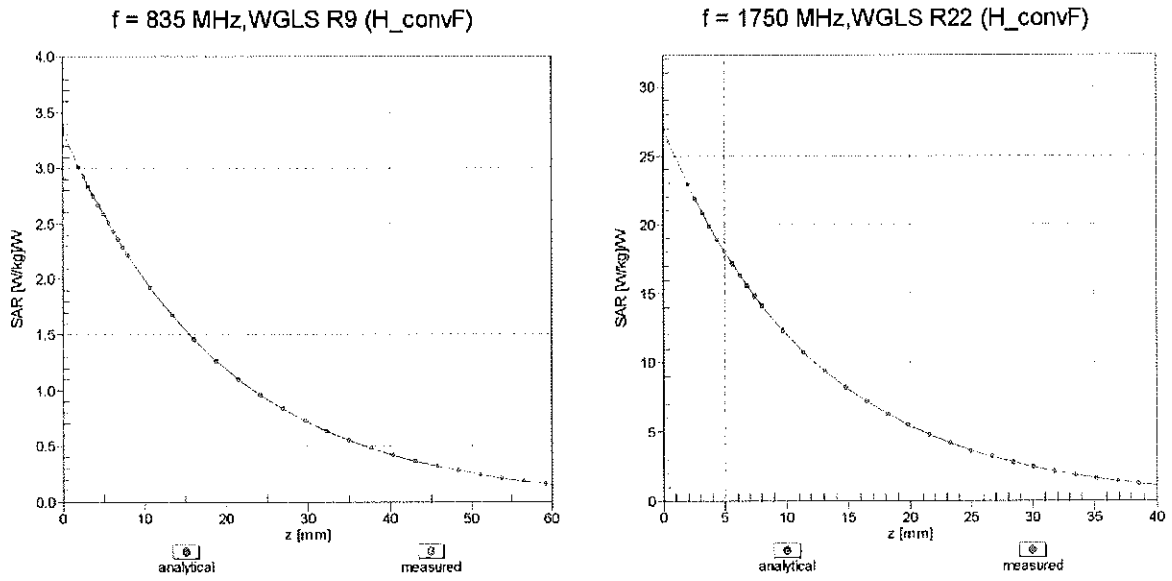

## Deviation from Isotropy in Liquid Error ( $\phi, \vartheta$ ), f = 900 MHz

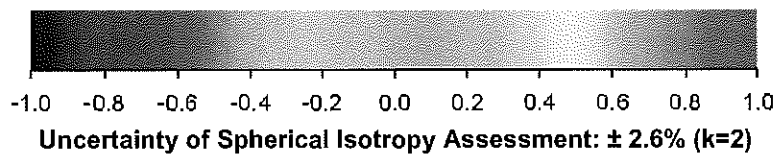
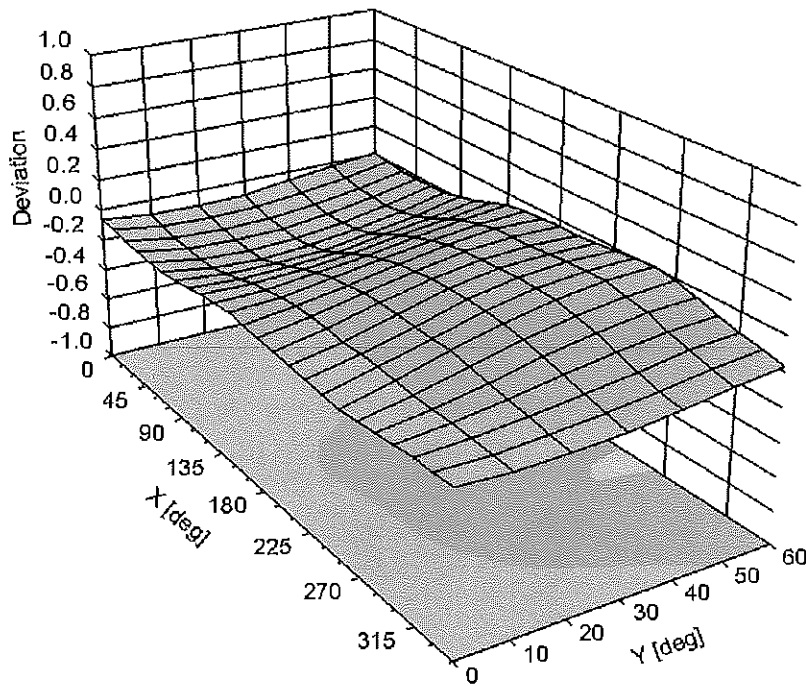

## DASY/EASY - Parameters of Probe: ES3DV3 - SN:3258

### Other Probe Parameters

Sensor Arrangement	Triangular
Connector Angle (°)	-123.1
Mechanical Surface Detection Mode	enabled
Optical Surface Detection Mode	disabled
Probe Overall Length	337 mm
Probe Body Diameter	10 mm
Tip Length	10 mm
Tip Diameter	4 mm
Probe Tip to Sensor X Calibration Point	2 mm
Probe Tip to Sensor Y Calibration Point	2 mm
Probe Tip to Sensor Z Calibration Point	2 mm
Recommended Measurement Distance from Surface	3 mm

## APPENDIX D: SAR TISSUE SPECIFICATIONS

Measurement Procedure for Tissue Verification:



- 1) The network analyzer and probe system was configured and calibrated.
- 2) The probe was immersed in the tissue. The tissue was placed in a nonmetallic container. Trapped air bubbles beneath the flange were minimized by placing the probe at a slight angle.
- 3) The complex admittance with respect to the probe aperture was measured
- 4) The complex relative permittivity  $\epsilon$  can be calculated from the below equation (Pournaropoulos and Misra):

$$Y = \frac{j2\omega\epsilon_r\epsilon_0}{[\ln(b/a)]^2} \int_a^b \int_a^b \int_0^\pi \cos\phi' \frac{\exp[-j\omega r(\mu_0\epsilon_r'\epsilon_0)^{1/2}]}{r} d\phi' d\rho' d\rho$$

where  $Y$  is the admittance of the probe in contact with the sample, the primed and unprimed coordinates refer to source and observation points, respectively,  $r^2 = \rho^2 + \rho'^2 - 2\rho\rho' \cos\phi'$ ,  $\omega$  is the angular frequency, and  $j = \sqrt{-1}$ .

**Table D-I**  
**Composition of the Tissue Equivalent Matter**

Frequency (MHz)	750	835	1750	1900	2450
Tissue	Body	Body	Body	Body	Body
Ingredients (% by weight)					
Bactericide	See Page 2	0.1			
DGBE			31	29.44	26.7
HEC		1			
NaCl		0.94	0.2	0.39	0.1
Sucrose		44.9			
Water		53.06	68.8	70.17	73.2

FCC ID: A3LSMV101M	 <b>PCTEST</b> <small>ENGINEERING LABORATORY, INC.</small>	<b>SAR EVALUATION REPORT</b>		Reviewed by: Quality Manager
Test Dates: 02/24/14 - 03/05/14	DUT Type: Portable Wireless Router			APPENDIX E: Page 1 of 1

## 2 Composition / Information on ingredients

The Item is composed of the following ingredients:

H <sub>2</sub> O	Water, 35 – 58%
Sucrose	Sugar, white, refined, 40 – 60%
NaCl	Sodium Chloride, 0 – 6%
Hydroxyethyl-cellulose	Medium Viscosity (CAS# 9004-62-0), <0.3%
Preventol-D7	Preservative: aqueous preparation, (CAS# 55965-84-9), containing 5-chloro-2-methyl-3(2H)-isothiazolone and 2-methyl-3(2H)-isothiazolone, 0.1 – 0.7%

Relevant for safety; Refer to the respective Safety Data Sheet\*.

**Figure D-1  
Composition of 750 MHz Body Tissue Equivalent Matter**

**Note:** 750MHz liquid recipes are proprietary SPEAG. Since the composition is approximate to the actual liquids utilized, the manufacturer tissue-equivalent liquid data sheets are provided below.

### Measurement Certificate / Material Test

Item Name	Body Tissue Simulating Liquid (MSL750V2)
Product No.	SL AAM 075 AA (Charge: 130313-1)
Manufacturer	SPEAG

### Measurement Method

TSL dielectric parameters measured using calibrated OCP probe.

### Setup Validation

Validation results were within  $\pm 2.5\%$  towards the target values of Methanol.

### Target Parameters

Target parameters as defined in the IEEE 1528 and IEC 62209 compliance standards.

### Test Condition

Ambient Environment temperature ( $22 \pm 3$ )°C and humidity < 70%.  
 TSL Temperature 22°C  
 Test Date 13-Mar-13  
 Operator IEN



### Additional Information

TSL Density 1.212 g/cm<sup>3</sup>  
 TSL Heat-capacity 3.006 kJ/(kg\*K)

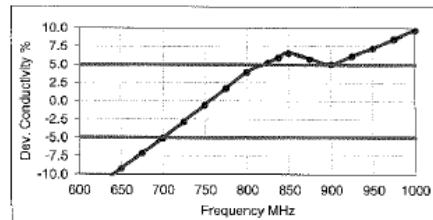
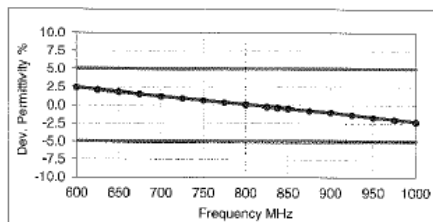
f [MHz]	Measured			Target		Diff. to Target [%]	
	HP-e'	HP-e''	sigma	eps	sigma	Δ-eps	Δ-sigma
600	57.5	24.64	0.82	56.1	0.95	2.5	-13.6
625	57.2	24.31	0.84	56.0	0.95	2.1	-11.4
650	57.0	23.99	0.87	55.9	0.96	1.8	-9.2
675	56.7	23.69	0.89	55.8	0.96	1.5	-7.1
700	56.4	23.39	0.91	55.7	0.96	1.2	-5.1
725	56.2	23.19	0.93	55.6	0.96	1.0	-2.8
<b>750</b>	<b>55.9</b>	<b>22.97</b>	<b>0.96</b>	<b>55.5</b>	<b>0.96</b>	<b>0.7</b>	<b>-0.5</b>
775	55.7	22.78	0.98	55.4	0.97	0.4	1.7
800	55.4	22.60	1.01	55.3	0.97	0.1	4.0
825	55.2	22.44	1.03	55.2	0.98	-0.2	5.3
838	55.0	22.36	1.04	55.2	0.98	-0.3	5.9
850	54.9	22.28	1.05	55.2	0.99	-0.4	6.6
875	54.7	22.16	1.08	55.1	1.02	-0.7	5.8
900	54.5	22.03	1.10	55.0	1.05	-1.0	5.1
925	54.2	21.93	1.13	55.0	1.06	-1.3	6.2
950	54.0	21.82	1.15	54.9	1.08	-1.7	7.2
975	53.8	21.74	1.18	54.9	1.09	-2.0	8.5
1000	53.6	21.66	1.21	54.8	1.10	-2.3	9.7



**Figure D-2  
750MHz Body Tissue Equivalent Matter**

FCC ID: A3LSMV101M	 PCTEST ENGINEERING LABORATORY, INC.	SAR EVALUATION REPORT		Reviewed by: Quality Manager
Test Dates: 02/24/14 - 03/05/14	DUT Type: Portable Wireless Router			APPENDIX E: Page 1 of 1

## APPENDIX E: SAR SYSTEM VALIDATION



Per FCC KDB 865664 D02v01r01, SAR system validation status should be documented to confirm measurement accuracy. The SAR systems (including SAR probes, system components and software versions) used for this device were validated against its performance specifications prior to the SAR measurements. Reference dipoles were used with the required tissue- equivalent media for system validation, according to the procedures outlined in IEEE 1528-2003 and FCC KDB 865664 D01v01r01. Since SAR probe calibrations are frequency dependent, each probe calibration point was validated at a frequency within the valid frequency range of the probe calibration point, using the system that normally operates with the probe for routine SAR measurements and according to the required tissue-equivalent media.

A tabulated summary of the system validation status including the validation date(s), measurement frequencies, SAR probes and tissue dielectric parameters has been included.

**Table E-I**  
**SAR System Validation Summary**

SAR SYSTEM #	FREQ. [MHz]	DATE	PROBE SN	PROBE TYPE	PROBE CAL. POINT		COND.	PERM.	CW VALIDATION			MOD. VALIDATION		
							( $\sigma$ )	( $\epsilon_r$ )	SENSI-TIVITY	PROBE LINEARITY	PROBE ISOTROPY	MOD. TYPE	DUTY FACTOR	PAR
H	750	6/19/2013	3318	ES3DV3	750	Body	0.986	56.00	PASS	PASS	PASS	N/A	N/A	N/A
G	835	1/6/2014	3209	ES3DV3	835	Body	0.989	53.83	PASS	PASS	PASS	GMSK	PASS	N/A
G	1750	1/13/2014	3209	ES3DV3	1750	Body	1.450	51.15	PASS	PASS	PASS	N/A	N/A	N/A
G	1900	1/13/2014	3209	ES3DV3	1900	Body	1.576	51.59	PASS	PASS	PASS	GMSK	PASS	N/A
G	2450	3/5/2014	3258	ES3DV3	2450	Body	2.044	51.30	PASS	PASS	PASS	OFDM	N/A	PASS

NOTE: While the probes have been calibrated for both a CW and modulated signals, all measurements were performed using communication systems calibrated for CW signals only. Modulations in the table above represent test configurations for which the measurement system has been validated per FCC KDB Publication 865664 D01v01 for scenarios when CW probe calibrations are used with other signal types. SAR systems were validated for modulated signals with a periodic duty cycle, such as GMSK, or with a high peak to average ratio (>5 dB), such as OFDM according to KDB 865664.

FCC ID: A3LSMV101M	 <b>PCTEST</b> ENGINEERING LABORATORY, INC.	<b>SAR EVALUATION REPORT</b>		<b>Reviewed by:</b> Quality Manager
<b>Test Dates:</b> 02/24/14 - 03/05/14	<b>DUT Type:</b> Portable Wireless Router			APPENDIX E: Page 1 of 1