



SAR EVALUATION REPORT

Applicant Name:
 Samsung Electronics Co., Ltd.
 129, Samsung-ro, Maetan dong,
 Yeongtong-gu, Suwon-si
 Gyeonggi-do, 16677, Korea

Date of Testing:
 08/05/19 - 08/27/19
Test Site/Location:
 PCTEST Lab, Columbia, MD, USA
Document Serial No.:
 1M1907300131-01-R1.A3L

FCC ID: A3LSMT867U

APPLICANT: SAMSUNG ELECTRONICS CO., LTD.

DUT Type: Portable Tablet
Application Type: Certification
FCC Rule Part(s): CFR §2.1093
Model: SM-T867U, SM-T867R4

Equipment Class	Band & Mode	Tx Frequency	SAR
			1g Body (W/kg)
PCB	UMTS 850	826.40 - 846.60 MHz	1.11
PCB	UMTS 1750	1712.4 - 1752.6 MHz	1.05
PCB	UMTS 1900	1852.4 - 1907.6 MHz	0.93
PCB	LTE Band 71	665.5 - 695.5 MHz	0.69
PCB	LTE Band 12	699.7 - 715.3 MHz	0.87
PCB	LTE Band 13	779.5 - 784.5 MHz	1.21
PCB	LTE Band 26 (Cell)	814.7 - 848.3 MHz	1.04
PCB	LTE Band 5 (Cell)	824.7 - 848.3 MHz	N/A
PCB	LTE Band 66 (AWS)	1710.7 - 1779.3 MHz	1.06
PCB	LTE Band 4 (AWS)	1710.7 - 1754.3 MHz	N/A
PCB	LTE Band 2 (PCS)	1850.7 - 1909.3 MHz	0.96
PCB	LTE Band 25 (PCS)	1850.7 - 1914.3 MHz	1.07
PCB	LTE Band 7	2502.5 - 2567.5 MHz	1.14
PCB	LTE Band 41	2498.5 - 2687.5 MHz	0.70
DTS	2.4 GHz WLAN	2412 - 2472 MHz	1.01
NII	U-NII-1	5180 - 5240 MHz	N/A
NII	U-NII-2A	5260 - 5320 MHz	0.73
NII	U-NII-2C	5500 - 5720 MHz	1.17
NII	U-NII-3	5745 - 5825 MHz	1.03
DSS/DTS	Bluetooth	2402 - 2480 MHz	0.92
Simultaneous SAR per KDB 690783 D01v01r03:			1.59

Note: This revised Test Report (S/N: 1M1907300131-01-R1.A3L) supersedes and replaces the previously issued test report on the same subject device for the same type of testing as indicated. Please discard or destroy the previously issued test report(s) and dispose of it accordingly.

This wireless portable device has been shown to be capable of compliance for localized specific absorption rate (SAR) for uncontrolled environment/general population exposure limits specified in ANSI/IEEE C95.1-1992 and has been tested in accordance with the measurement procedures specified in Section 1.7 of this report; for North American frequency bands only.

I attest to the accuracy of data. All measurements reported herein were performed by me or were made under my supervision and are correct to the best of my knowledge and belief. I assume full responsibility for the completeness of these measurements and vouch for the qualifications of all persons taking them. Test results reported herein relate only to the item(s) tested.

Randy Ortanez
 President





The SAR Tick is an initiative of the Mobile & Wireless Forum (MWF). While a product may be considered eligible, use of the SAR Tick logo requires an agreement with the MWF. Further details can be obtained by emailing: sartick@mwfai.info.

FCC ID: A3LSMT867U		SAR EVALUATION REPORT		Approved by: Quality Manager
Document S/N: 1M1907300131-01-R1.A3L	Test Dates: 08/05/19 - 08/27/19	DUT Type: Portable Tablet	Page 1 of 126	

TABLE OF CONTENTS

1	DEVICE UNDER TEST	3
2	LTE INFORMATION	11
3	INTRODUCTION	12
4	DOSIMETRIC ASSESSMENT	13
5	TEST CONFIGURATION POSITIONS	14
6	RF EXPOSURE LIMITS	15
7	FCC MEASUREMENT PROCEDURES.....	16
8	RF CONDUCTED POWERS.....	21
9	SYSTEM VERIFICATION.....	74
10	SAR DATA SUMMARY	76
11	FCC MULTI-TX AND ANTENNA SAR CONSIDERATIONS.....	88
12	SAR MEASUREMENT VARIABILITY	116
13	ADDITIONAL TESTING PER FCC GUIDANCE	117
14	EQUIPMENT LIST.....	122
15	MEASUREMENT UNCERTAINTIES.....	123
16	CONCLUSION.....	124
17	REFERENCES	125
APPENDIX A: SAR TEST PLOTS		
APPENDIX B: SAR DIPOLE VERIFICATION PLOTS		
APPENDIX C: PROBE AND DIPOLE CALIBRATION CERTIFICATES		
APPENDIX D: SAR TISSUE SPECIFICATIONS		
APPENDIX E: SAR SYSTEM VALIDATION		
APPENDIX F: DUT ANTENNA DIAGRAM & SAR TEST SETUP PHOTOGRAPHS		
APPENDIX G: POWER REDUCTION VERIFICATION		
APPENDIX H: DOWNLINK LTE CA RF CONDUCTED POWERS		

FCC ID: A3LSMT867U		SAR EVALUATION REPORT		Approved by: Quality Manager
Document S/N: 1M1907300131-01-R1.A3L	Test Dates: 08/05/19 - 08/27/19	DUT Type: Portable Tablet	Page 2 of 126	



1 DEVICE UNDER TEST

1.1 Device Overview

Band & Mode	Operating Modes	Tx Frequency
UMTS 850	Data	826.40 - 846.60 MHz
UMTS 1750	Data	1712.4 - 1752.6 MHz
UMTS 1900	Data	1852.4 - 1907.6 MHz
LTE Band 71	Data	665.5 - 695.5 MHz
LTE Band 12	Data	699.7 - 715.3 MHz
LTE Band 13	Data	779.5 - 784.5 MHz
LTE Band 26 (Cell)	Data	814.7 - 848.3 MHz
LTE Band 5 (Cell)	Data	824.7 - 848.3 MHz
LTE Band 66 (AWS)	Data	1710.7 - 1779.3 MHz
LTE Band 4 (AWS)	Data	1710.7 - 1754.3 MHz
LTE Band 2 (PCS)	Data	1850.7 - 1909.3 MHz
LTE Band 25 (PCS)	Data	1850.7 - 1914.3 MHz
LTE Band 7	Data	2502.5 - 2567.5 MHz
LTE Band 41	Data	2498.5 - 2687.5 MHz
2.4 GHz WLAN	Data	2412 - 2472 MHz
U-NII-1	Data	5180 - 5240 MHz
U-NII-2A	Data	5260 - 5320 MHz
U-NII-2C	Data	5500 - 5720 MHz
U-NII-3	Data	5745 - 5825 MHz
Bluetooth	Data	2402 - 2480 MHz
ANT+	Data	2402 - 2480 MHz

1.2 Power Reduction for SAR

This device uses a power reduction mechanism for SAR compliance. The power reduction mechanism is activated when the device is used in close proximity to the user's body. FCC KDB Publication 616217 D04v01r02 Section 6 was used as a guideline for selecting SAR test distances for this device. Detailed descriptions of the power reduction mechanism are included in the operational description.

FCC ID: A3LSMT867U		SAR EVALUATION REPORT		Approved by: Quality Manager
Document S/N: 1M1907300131-01-R1.A3L	Test Dates: 08/05/19 - 08/27/19	DUT Type: Portable Tablet	Page 3 of 126	



1.3 Nominal and Maximum Output Power Specifications

This device operates using the following maximum and nominal output power specifications. SAR values were scaled to the maximum allowed power to determine compliance per KDB Publication 447498 D01v06.

1.3.1 Maximum Output Power

Mode / Band		Modulated Average (dBm)			
		3GPP WCDMA	3GPP HSDPA	3GPP HSUPA	3GPP DC-HSDPA
UMTS Band 5 (850 MHz)	Maximum	24.5	23.5	23.5	23.5
	Nominal	23.5	22.5	22.5	22.5
UMTS Band 4 (1750 MHz)	Maximum	25.0	24.0	24.0	24.0
	Nominal	24.0	23.0	23.0	23.0
UMTS Band 2 (1900 MHz)	Maximum	24.0	23.0	23.0	23.0
	Nominal	23.0	22.0	22.0	22.0

Mode / Band		Modulated Average (dBm)
LTE Band 71	Maximum	25.5
	Nominal	24.5
LTE Band 12	Maximum	25.5
	Nominal	24.5
LTE Band 13	Maximum	25.0
	Nominal	24.0
LTE Band 26 (Cell)	Maximum	25.0
	Nominal	24.0
LTE Band 5 (Cell)	Maximum	25.0
	Nominal	24.0
LTE Band 66 (AWS)	Maximum	25.5
	Nominal	24.5
LTE Band 4 (AWS)	Maximum	25.5
	Nominal	24.5
LTE Band 2 (PCS)	Maximum	25.0
	Nominal	24.0
LTE Band 25 (PCS)	Maximum	24.5
	Nominal	23.5
LTE Band 7	Maximum	23.5
	Nominal	22.5
LTE Band 41 (PC3)	Maximum	24.5
	Nominal	23.5
LTE Band 41 (PC2)	Maximum	27.5
	Nominal	26.5



FCC ID: A3LSMT867U	 PCTEST ENGINEERING LABORATORY, INC.	SAR EVALUATION REPORT		Approved by: Quality Manager
Document S/N: 1M1907300131-01-R1.A3L	Test Dates: 08/05/19 - 08/27/19	DUT Type: Portable Tablet		Page 4 of 126

Mode / Band		Modulated Average - Single Tx Chain (dBm)								
Channel		1	2	3 - 8	9	10	11	12	13	
IEEE 802.11b (2.4 GHz)	Maximum	18.5	20.0			18.5	6.0	6.0		
	Nominal	17.5	19.0			17.5	5.0	5.0		
IEEE 802.11g (2.4 GHz)	Maximum	15.0	16.5	18.0	16.0	14.5	6.0	3.5		
	Nominal	14.0	15.5	17.0	15.0	13.5	5.0	2.5		
IEEE 802.11n (2.4 GHz)	Maximum	13.5	17.5	19.0	17.0	16.5	13.5	6.0	2.0	
	Nominal	12.5	16.5	18.0	16.0	15.5	12.5	5.0	1.0	
Mode / Band		Modulated Average (dBm)								
Bluetooth	Maximum	13.0								
	Nominal	12.0								
Bluetooth LE	Maximum	6.0								
	Nominal	5.0								

Mode / Band		Modulated Average - Single Tx Chain (dBm)		
		20 MHz Bandwidth	40 MHz Bandwidth	80 MHz Bandwidth
IEEE 802.11a (5 GHz)	Maximum	18.0		
	Nominal	17.0		
IEEE 802.11n (5 GHz)	Maximum	18.0	13.0	
	Nominal	17.0	12.0	
IEEE 802.11ac (5 GHz)	Maximum	13.0	13.0	13.0
	Nominal	12.0	12.0	12.0

Mode / Band		Modulated Average - MIMO (dBm)								
Channel		1	2	3 - 8	9	10	11	12	13	
IEEE 802.11g (2.4 GHz)	Maximum	18.0	19.5	21.0	19.0	17.5	9.0	6.5		
	Nominal	17.0	18.5	20.0	18.0	16.5	8.0	5.5		
IEEE 802.11n (2.4 GHz)	Maximum	16.5	20.5	22.0	20.0	19.5	16.5	9.0	5.0	
	Nominal	15.5	19.5	21.0	19.0	18.5	15.5	8.0	4.0	



Mode / Band		Modulated Average - MIMO (dBm)		
		20 MHz Bandwidth	40 MHz Bandwidth	80 MHz Bandwidth
IEEE 802.11a (5 GHz)	Maximum	21.0		
	Nominal	20.0		
IEEE 802.11n (5 GHz)	Maximum	21.0	16.0	
	Nominal	20.0	15.0	
IEEE 802.11ac (5 GHz)	Maximum	16.0	16.0	16.0
	Nominal	15.0	15.0	15.0

FCC ID: A3LSMT867U	 PCTEST ENGINEERING LABORATORY, INC.	SAR EVALUATION REPORT		Approved by: Quality Manager
Document S/N: 1M1907300131-01-R1.A3L	Test Dates: 08/05/19 - 08/27/19	DUT Type: Portable Tablet	Page 5 of 126	

1.3.2 Reduced Output Power

Mode / Band		Modulated Average (dBm)			
		3GPP WCDMA	3GPP HSDPA	3GPP HSUPA	3GPP DC- HSDPA
UMTS Band 5 (850 MHz)	Maximum	18.0	17.0	17.0	17.0
	Nominal	17.0	16.0	16.0	16.0
UMTS Band 4 (1750 MHz)	Maximum	14.0	13.5	13.5	13.5
	Nominal	13.0	12.5	12.5	12.5
UMTS Band 2 (1900 MHz)	Maximum	14.5	14.0	14.5	14.0
	Nominal	13.5	13.0	13.5	13.0

Mode / Band		Modulated Average (dBm)
LTE Band 71	Maximum	18.0
	Nominal	17.0
LTE Band 12	Maximum	18.0
	Nominal	17.0
LTE Band 13	Maximum	19.0
	Nominal	18.0
LTE Band 26 (Cell)	Maximum	18.0
	Nominal	17.0
LTE Band 5 (Cell)	Maximum	18.0
	Nominal	17.0
LTE Band 66 (AWS)	Maximum	14.5
	Nominal	13.5
LTE Band 4 (AWS)	Maximum	14.5
	Nominal	13.5
LTE Band 2 (PCS)	Maximum	14.5
	Nominal	13.5
LTE Band 25 (PCS)	Maximum	14.5
	Nominal	13.5
LTE Band 7	Maximum	14.5
	Nominal	13.5
LTE Band 41 (PC3)	Maximum	14.0
	Nominal	13.0
LTE Band 41 (PC2)	Maximum	14.0
	Nominal	13.0



FCC ID: A3LSMT867U	 PCTEST ENGINEERING LABORATORY, INC.	SAR EVALUATION REPORT		Approved by: Quality Manager
Document S/N: 1M1907300131-01-R1.A3L	Test Dates: 08/05/19 - 08/27/19	DUT Type: Portable Tablet	Page 6 of 126	

Mode / Band		Modulated Average - Single Tx Chain (dBm)								
Channel		1	2	3 - 8	9	10	11	12	13	
IEEE 802.11b (2.4 GHz)	Maximum	13.5						6.0	6.0	
	Nominal	12.5						5.0	5.0	
IEEE 802.11g (2.4 GHz)	Maximum	13.5						6.0	3.5	
	Nominal	12.5						5.0	2.5	
IEEE 802.11n (2.4 GHz)	Maximum	13.5						6.0	2.0	
	Nominal	12.5						5.0	1.0	

Mode / Band		Modulated Average - Single Tx Chain (dBm)			
		20 MHz Bandwidth	40 MHz Bandwidth	80 MHz Bandwidth	
IEEE 802.11a (5 GHz)	Maximum	9.0			
	Nominal	8.0			
IEEE 802.11n (5 GHz)	Maximum	9.0			
	Nominal	8.0			
IEEE 802.11ac (5 GHz)	Maximum	9.0			9.0
	Nominal	8.0			8.0

Mode / Band		Modulated Average - MIMO (dBm)								
Channel		1	2	3 - 8	9	10	11	12	13	
IEEE 802.11g (2.4 GHz)	Maximum	16.5						9.0	6.5	
	Nominal	15.5						8.0	5.5	
IEEE 802.11n (2.4 GHz)	Maximum	16.5						9.0	5.0	
	Nominal	15.5						8.0	4.0	

Mode / Band		Modulated Average - MIMO (dBm)			
		20 MHz Bandwidth	40 MHz Bandwidth	80 MHz Bandwidth	
IEEE 802.11a (5 GHz)	Maximum	9.0			
	Nominal	8.0			
IEEE 802.11n (5 GHz)	Maximum	9.0			
	Nominal	8.0			
IEEE 802.11ac (5 GHz)	Maximum	9.0			9.0
	Nominal	8.0			8.0

FCC ID: A3LSMT867U		SAR EVALUATION REPORT		Approved by: Quality Manager
Document S/N: 1M1907300131-01-R1.A3L	Test Dates: 08/05/19 - 08/27/19	DUT Type: Portable Tablet	Page 7 of 126	

1.4 DUT Antenna Locations

The overall diagonal dimension of the device is > 200 mm. A diagram showing the location of the device antennas can be found in Appendix F. Exact antenna dimensions and separation distances are shown in the Technical Descriptions in the FCC filings.

**Table 1-1
Device Edges/Sides for SAR Testing**



Mode	Back	Top	Bottom	Right	Left
UMTS 850	Yes	Yes	No	Yes	Yes
UMTS 1750	Yes	Yes	No	Yes	Yes
UMTS 1900	Yes	Yes	No	Yes	Yes
LTE Band 71	Yes	Yes	No	Yes	Yes
LTE Band 12	Yes	Yes	No	Yes	Yes
LTE Band 13	Yes	Yes	No	Yes	Yes
LTE Band 26 (Cell)	Yes	Yes	No	Yes	Yes
LTE Band 66 (AWS)	Yes	Yes	No	Yes	Yes
LTE Band 2 (PCS)	Yes	Yes	No	Yes	Yes
LTE Band 25 (PCS)	Yes	Yes	No	Yes	Yes
LTE Band 7	Yes	Yes	No	Yes	Yes
LTE Band 41	Yes	Yes	No	Yes	Yes
2.4 GHz WLAN Ant 1	Yes	Yes	No	No	Yes
2.4 GHz WLAN Ant 2	Yes	Yes	No	Yes	No
5 GHz WLAN Ant 1	Yes	Yes	No	No	Yes
5 GHz WLAN Ant 2	Yes	Yes	No	Yes	No
Bluetooth	Yes	Yes	No	No	Yes

Note: Per FCC KDB Publication 616217 D04v01r01, particular edges were not required to be evaluated for SAR based on the SAR exclusion threshold in KDB 447498 D01V06. Additional edges may have been evaluated for simultaneous transmission analysis.

1.5 Simultaneous Transmission Capabilities

According to FCC KDB Publication 447498 D01v06, transmitters are considered to be operating simultaneously when there is overlapping transmission, with the exception of transmissions during network hand-offs with maximum hand-off duration less than 30 seconds.

This device contains multiple transmitters that may operate simultaneously, and therefore requires a simultaneous transmission analysis according to FCC KDB Publication 447498 D01v06 4.3.2 procedures.

FCC ID: A3LSMT867U	 PCTEST ENGINEERING LABORATORY, INC.	SAR EVALUATION REPORT		Approved by: Quality Manager
Document S/N: 1M1907300131-01-R1.A3L	Test Dates: 08/05/19 - 08/27/19	DUT Type: Portable Tablet	Page 8 of 126	

**Table 1-2
Simultaneous Transmission Scenarios**

No.	Capable Transmit Configuration	Body
1	UMTS + 2.4 GHz WI-FI	Yes
2	UMTS + 5 GHz WI-FI	Yes
3	UMTS + 2.4 GHz Bluetooth	Yes
4	UMTS + 2.4 GHz WI-FI MIMO	Yes
5	UMTS + 5 GHz WI-FI MIMO	Yes
6	UMTS + 2.4 GHz WI-FI Ant 1 + 5 GHz WI-FI Ant 2	Yes
7	UMTS + 2.4 GHz Bluetooth + 5 GHz WI-FI Ant 2	Yes
8	LTE + 2.4 GHz WI-FI	Yes
9	LTE + 5 GHz WI-FI	Yes
10	LTE + 2.4 GHz Bluetooth	Yes
11	LTE + 2.4 GHz WI-FI MIMO	Yes
12	LTE + 5 GHz WI-FI MIMO	Yes
13	LTE + 2.4 GHz WI-FI Ant 1 + 5 GHz WI-FI Ant 2	Yes
14	LTE + 2.4 GHz Bluetooth + 5 GHz WI-FI Ant 2	Yes

- 2.4 GHz WLAN Ant 1, 5 GHz WLAN Ant 1, and 2.4 GHz Bluetooth share the same antenna path and cannot transmit simultaneously.
- All licensed modes share the same antenna path and cannot transmit simultaneously.
- This device supports 2x2 MIMO Tx for WLAN 802.11a/g/n/ac. 802.11a/g/n/ac supports CDD and STBC and 802.11n/ac additionally supports SDM. Each WLAN antenna can transmit independently or together when operating with MIMO.

1.6 Miscellaneous SAR Test Considerations

(A) WIFI/BT

Since U-NII-1 and U-NII-2A bands have the same maximum output power and the highest reported SAR for U-NII-2A is less than 1.2 W/kg, SAR is not required for U-NII-1 band according to FCC KDB Publication 248227 D01v02r02.

This device supports IEEE 802.11ac with the following features:



- Up to 80 MHz Bandwidth only
- No aggregate channel configurations
- 2 Tx antenna output
- 256 QAM is supported
- TDWR and Band gap channels are supported

(B) Licensed Transmitter(s)

This device is only capable of QPSK HSUPA in the uplink. Therefore, no additional SAR tests are required beyond that described for devices with HSUPA in KDB 941225 D01v03r01.

LTE SAR for the higher modulations and lower bandwidths were not tested since the maximum average output power of all required channels and configurations was not more than 0.5 dB higher than the highest bandwidth; and the reported LTE SAR for the highest bandwidth was less than 1.45 W/kg for all configurations according to FCC KDB 941225 D05v02r04.

This device supports LTE Carrier Aggregation (CA) in the downlink. All uplink communications are identical to Release 8 specifications. Per FCC KDB Publication 941225 D05A v01r02, SAR for LTE CA operations was

FCC ID: A3LSMT867U		SAR EVALUATION REPORT		Approved by: Quality Manager
Document S/N: 1M1907300131-01-R1.A3L	Test Dates: 08/05/19 - 08/27/19	DUT Type: Portable Tablet	Page 9 of 126	

not needed since the maximum average output power in LTE CA mode was not >0.25 dB higher than the maximum output power when downlink carrier aggregation was inactive. The downlink carrier aggregation exclusion analysis can be found in Appendix H.

This device supports LTE capabilities with overlapping transmission frequency ranges. When the supported frequency range of an LTE Band falls completely within an LTE band with a larger transmission frequency range, both LTE bands have the same target power (or the band with the larger transmission frequency range has a higher target power), and both LTE bands share the same transmission path and signal characteristics, SAR was only assessed for the band with the larger transmission frequency range.

This device supports downlink 4x4 MIMO operations for some LTE Bands. Per May 2017 TCB Workshop Notes, SAR for 4x4 DL MIMO was not needed since the maximum average output power in 4x4 DL MIMO mode was not more than 0.25 dB higher than the maximum output power with 4x4 DL MIMO inactive. Additionally, SAR for 4x4 MIMO Downlink Carrier Aggregation was not needed since the maximum average output power in 4x4 MIMO Downlink Carrier Aggregation mode was not more than 0.25 dB higher than the maximum output power with 4x4 MIMO Downlink and downlink carrier aggregation inactive.

This device supports 64QAM on the uplink and 256QAM on the downlink for LTE Operations. Conducted powers for 64QAM uplink configurations were measured per Section 5.1 of FCC KDB Publication 941225 D05v02r05. SAR was not required for 64QAM since the highest maximum output power for 64QAM is $\leq \frac{1}{2}$ dB higher than the same configuration in QPSK and the reported SAR for the QPSK configuration is ≤ 1.45 W/kg, per Section 5.2.4 of FCC KDB Publication 941225 D05v02r05.



This device supports LTE Carrier Aggregation (CA) for LTE Band 66 and LTE Band 41 with two component carriers in the uplink. SAR Measurements and conducted powers were evaluated per 2017 Fall TCB Workshop Notes.

1.7 Guidance Applied



- FCC KDB Publication 941225 D01v03r01, D05v02r04, D05Av01r02, D06v02r01 (2G/3G/4G)
- FCC KDB Publication 248227 D01v02r02 (SAR Considerations for 802.11 Devices)
- FCC KDB Publication 447498 D01v06 (General SAR Guidance)
- FCC KDB Publication 865664 D01v01r04, D02v01r02 (SAR Measurements up to 6 GHz)
- FCC KDB Publication 616217 D04v01r02 (Tablet)
- May 2017 TCB Workshop Notes (LTE 4x4 Downlink MIMO, LTE Band 41 Power Class 2/3)
- April 2018 TCB Workshop Notes (LTE Carrier Aggregation)
- April 2019 TCB Workshop Notes (Dynamic Antenna Tuning)

1.8 Device Serial Numbers

Several samples with identical hardware were used to support SAR testing. The manufacturer has confirmed that the device(s) tested have the same physical, mechanical and thermal characteristics and are within operational tolerances expected for production units. The serial numbers used for each test are indicated alongside the results in Section 10.

FCC ID: A3LSMT867U		SAR EVALUATION REPORT		Approved by: Quality Manager
Document S/N: 1M1907300131-01-R1.A3L	Test Dates: 08/05/19 - 08/27/19	DUT Type: Portable Tablet	Page 10 of 126	

LTE Information						
Form Factor	Portable Tablet					
Frequency Range of each LTE transmission band	LTE Band 71 (665.5 - 695.5 MHz)					
	LTE Band 12 (699.7 - 715.3 MHz)					
	LTE Band 13 (779.5 - 794.5 MHz)					
	LTE Band 26 (Cell) (814.7 - 848.3 MHz)					
	LTE Band 5 (Cell) (824.7 - 848.3 MHz)					
	LTE Band 66 (AWS) (1710.7 - 1779.3 MHz)					
	LTE Band 4 (AWS) (1710.7 - 1754.3 MHz)					
	LTE Band 2 (PCS) (1850.7 - 1909.3 MHz)					
	LTE Band 25 (PCS) (1850.7 - 1914.3 MHz)					
	LTE Band 7 (2502.5 - 2567.5 MHz)					
	LTE Band 41 (2498.5 - 2687.5 MHz)					
	Channel Bandwidths	LTE Band 71: 5 MHz, 10 MHz, 15 MHz, 20 MHz				
		LTE Band 12: 1.4 MHz, 3 MHz, 5 MHz, 10 MHz				
LTE Band 13: 5 MHz, 10 MHz						
LTE Band 26 (Cell): 1.4 MHz, 3 MHz, 5 MHz, 10 MHz, 15 MHz						
LTE Band 5 (Cell): 1.4 MHz, 3 MHz, 5 MHz, 10 MHz						
LTE Band 66 (AWS): 1.4 MHz, 3 MHz, 5 MHz, 10 MHz, 15 MHz, 20 MHz						
LTE Band 4 (AWS): 1.4 MHz, 3 MHz, 5 MHz, 10 MHz, 15 MHz, 20 MHz						
LTE Band 2 (PCS): 1.4 MHz, 3 MHz, 5 MHz, 10 MHz, 15 MHz, 20 MHz						
LTE Band 25 (PCS): 1.4 MHz, 3 MHz, 5 MHz, 10 MHz, 15 MHz, 20 MHz						
LTE Band 7: 5 MHz, 10 MHz, 15 MHz, 20 MHz						
LTE Band 41: 5 MHz, 10 MHz, 15 MHz, 20 MHz						
Channel Numbers and Frequencies (MHz)		Low	Low-Mid	Mid	Mid-High	High
LTE Band 71: 5 MHz	665.5 (133147)		680.5 (133297)		695.5 (133447)	
LTE Band 71: 10 MHz	668 (133172)		680.5 (133297)		693 (133422)	
LTE Band 71: 15 MHz	670.5 (133197)		680.5 (133297)		690.5 (133397)	
LTE Band 71: 20 MHz	673 (133222)		680.5 (133297)		688 (133372)	
LTE Band 12: 1.4 MHz	699.7 (23017)		707.5 (23095)		715.3 (23173)	
LTE Band 12: 3 MHz	700.5 (23025)		707.5 (23095)		714.5 (23165)	
LTE Band 12: 5 MHz	701.5 (23035)		707.5 (23095)		713.5 (23155)	
LTE Band 12: 10 MHz	704 (23060)		707.5 (23095)		711 (23130)	
LTE Band 13: 5 MHz	779.5 (23205)		782 (23230)		784.5 (23255)	
LTE Band 13: 10 MHz	N/A		782 (23230)		N/A	
LTE Band 26 (Cell): 1.4 MHz	814.7 (26697)		831.5 (26865)		848.3 (27033)	
LTE Band 26 (Cell): 3 MHz	815.5 (26705)		831.5 (26865)		847.5 (27025)	
LTE Band 26 (Cell): 5 MHz	816.5 (26715)		831.5 (26865)		846.5 (27015)	
LTE Band 26 (Cell): 10 MHz	819 (26740)		831.5 (26865)		844 (26990)	
LTE Band 26 (Cell): 15 MHz	821.5 (26765)		831.5 (26865)		841.5 (26965)	
LTE Band 5 (Cell): 1.4 MHz	824.7 (20407)		836.5 (20525)		848.3 (20643)	
LTE Band 5 (Cell): 3 MHz	825.5 (20415)		836.5 (20525)		847.5 (20635)	
LTE Band 5 (Cell): 5 MHz	826.5 (20425)		836.5 (20525)		846.5 (20625)	
LTE Band 5 (Cell): 10 MHz	829 (20450)		836.5 (20525)		844 (20600)	
LTE Band 66 (AWS): 1.4 MHz	1710.7 (131979)		1745 (132322)		1779.3 (132685)	
LTE Band 66 (AWS): 3 MHz	1711.5 (131987)		1745 (132322)		1778.5 (132657)	
LTE Band 66 (AWS): 5 MHz	1712.5 (131997)		1745 (132322)		1777.5 (132647)	
LTE Band 66 (AWS): 10 MHz	1715 (132022)		1745 (132322)		1775 (132622)	
LTE Band 66 (AWS): 15 MHz	1717.5 (132047)		1745 (132322)		1772.5 (132597)	
LTE Band 66 (AWS): 20 MHz	1720 (132072)		1745 (132322)		1770 (132572)	
LTE Band 4 (AWS): 1.4 MHz	1710.7 (19957)		1732.5 (20175)		1754.3 (20393)	
LTE Band 4 (AWS): 3 MHz	1711.5 (19965)		1732.5 (20175)		1753.5 (20385)	
LTE Band 4 (AWS): 5 MHz	1712.5 (19975)		1732.5 (20175)		1752.5 (20375)	
LTE Band 4 (AWS): 10 MHz	1715 (20000)		1732.5 (20175)		1750 (20350)	
LTE Band 4 (AWS): 15 MHz	1717.5 (20025)		1732.5 (20175)		1747.5 (20325)	
LTE Band 4 (AWS): 20 MHz	1720 (20050)		1732.5 (20175)		1745 (20300)	
LTE Band 2 (PCS): 1.4 MHz	1850.7 (18607)		1880 (18900)		1909.3 (19193)	
LTE Band 2 (PCS): 3 MHz	1851.5 (18615)		1880 (18900)		1908.5 (19185)	
LTE Band 2 (PCS): 5 MHz	1852.5 (18625)		1880 (18900)		1907.5 (19175)	
LTE Band 2 (PCS): 10 MHz	1855 (18650)		1880 (18900)		1905 (19150)	
LTE Band 2 (PCS): 15 MHz	1857.5 (18675)		1880 (18900)		1902.5 (19125)	
LTE Band 2 (PCS): 20 MHz	1860 (18700)		1880 (18900)		1900 (19100)	
LTE Band 25 (PCS): 1.4 MHz	1850.7 (26047)		1882.5 (26365)		1914.3 (26683)	
LTE Band 25 (PCS): 3 MHz	1851.5 (26055)		1882.5 (26365)		1913.5 (26675)	
LTE Band 25 (PCS): 5 MHz	1852.5 (26065)		1882.5 (26365)		1912.5 (26665)	
LTE Band 25 (PCS): 10 MHz	1855 (26090)		1882.5 (26365)		1910 (26640)	
LTE Band 25 (PCS): 15 MHz	1857.5 (26115)		1882.5 (26365)		1907.5 (26615)	
LTE Band 25 (PCS): 20 MHz	1860 (26140)		1882.5 (26365)		1905 (26590)	
LTE Band 7: 5 MHz	2502.5 (20775)		2535 (21100)		2567.5 (21425)	
LTE Band 7: 10 MHz	2505 (20800)		2535 (21100)		2565 (21400)	
LTE Band 7: 15 MHz	2507.5 (20825)		2535 (21100)		2562.5 (21375)	
LTE Band 7: 20 MHz	2510 (20850)		2535 (21100)		2560 (21350)	
LTE Band 41: 5 MHz	2506 (39750)	2549.5 (40185)	2593 (40620)	2636.5 (41055)	2680 (41490)	
LTE Band 41: 10 MHz	2506 (39750)	2549.5 (40185)	2593 (40620)	2636.5 (41055)	2680 (41490)	
LTE Band 41: 15 MHz	2506 (39750)	2549.5 (40185)	2593 (40620)	2636.5 (41055)	2680 (41490)	
LTE Band 41: 20 MHz	2506 (39750)	2549.5 (40185)	2593 (40620)	2636.5 (41055)	2680 (41490)	
UE Category	DL UE Cat 20, UL UE Cat 13					
Modulations Supported in UL	QPSK, 16QAM, 64QAM					
LTE MPR Permanently implemented per 3GPP TS 36.101 section 6.2.3-6.2.5? (manufacturer attestation to be provided)	YES					
A-MPR (Additional MPR) disabled for SAR Testing?	YES					
LTE Carrier Aggregation Possible Combinations	The technical description includes all the possible carrier aggregation combinations					
LTE Additional Information	This device does not support full CA features on 3GPP Release 14. It supports carrier aggregation, downlink MIMO, LAA features as shown in Section 9 and Appendix H. All other uplink communications are identical to the Release 8 specifications. Uplink communications are done on the PCC unless otherwise specified. The following LTE Release 14 Features are not supported: Relay, HetNet, Enhanced MIMO, eICIC, eMBMS, Cross-Carrier Scheduling, Enhanced SC-FDMA.					

FCC ID: A3LSMT867U		SAR EVALUATION REPORT			Approved by: Quality Manager
Document S/N: 1M1907300131-01-R1.A3L	Test Dates: 08/05/19 - 08/27/19	DUT Type: Portable Tablet	Page 11 of 126		

The FCC and Innovation, Science, and Economic Development Canada have adopted the guidelines for evaluating the environmental effects of radio frequency (RF) radiation in ET Docket 93-62 on Aug. 6, 1996 and Health Canada Safety Code 6 to protect the public and workers from the potential hazards of RF emissions due to FCC-regulated portable devices. [1]

The safety limits used for the environmental evaluation measurements are based on the criteria published by the American National Standards Institute (ANSI) for localized specific absorption rate (SAR) in IEEE/ANSI C95.1-1992 Standard for Safety Levels with Respect to Human Exposure to Radio Frequency Electromagnetic Fields, 3 kHz to 300 GHz [3] and Health Canada RF Exposure Guidelines Safety Code 6 [22]. The measurement procedure described in IEEE/ANSI C95.3-2002 Recommended Practice for the Measurement of Potentially Hazardous Electromagnetic Fields - RF and Microwave [4] is used for guidance in measuring the Specific Absorption Rate (SAR) due to the RF radiation exposure from the Equipment Under Test (EUT). These criteria for SAR evaluation are similar to those recommended by the International Committee for Non-ionizing Radiation Protection (ICNIRP) in Biological Effects and Exposure Criteria for Radiofrequency Electromagnetic Fields,” Report No. Vol 74. SAR is a measure of the rate of energy absorption due to exposure to an RF transmitting source. SAR values have been related to threshold levels for potential biological hazards.

3.1 SAR Definition

Specific Absorption Rate is defined as the time derivative (rate) of the incremental energy (dU) absorbed by (dissipated in) an incremental mass (dm) contained in a volume element (dV) of a given density (ρ). It is also defined as the rate of RF energy absorption per unit mass at a point in an absorbing body (see Equation 3-1).

Equation 3-1
SAR Mathematical Equation

$$SAR = \frac{d}{dt} \left(\frac{dU}{dm} \right) = \frac{d}{dt} \left(\frac{dU}{\rho dv} \right)$$



SAR is expressed in units of Watts per Kilogram (W/kg).

$$SAR = \frac{\sigma \cdot E^2}{\rho}$$

where:

- σ = conductivity of the tissue-simulating material (S/m)
- ρ = mass density of the tissue-simulating material (kg/m³)
- E = Total RMS electric field strength (V/m)

NOTE: The primary factors that control rate of energy absorption were found to be the wavelength of the incident field in relation to the dimensions and geometry of the irradiated organism, the orientation of the organism in relation to the polarity of field vectors, the presence of reflecting surfaces, and whether conductive contact is made by the organism with a ground plane.[6]

FCC ID: A3LSMT867U	 PCTEST ENGINEERING LABORATORY, INC.	SAR EVALUATION REPORT		Approved by: Quality Manager
Document S/N: 1M1907300131-01-R1.A3L	Test Dates: 08/05/19 - 08/27/19	DUT Type: Portable Tablet	Page 12 of 126	

4 DOSIMETRIC ASSESSMENT

4.1 Measurement Procedure

The evaluation was performed using the following procedure compliant to FCC KDB Publication 865664 D01v01r04 and IEEE 1528-2013:

1. The SAR distribution at the exposed side of the head or body was measured at a distance no greater than 5.0 mm from the inner surface of the shell. The area covered the entire dimension of the device-head and body interface and the horizontal grid resolution was determined per FCC KDB Publication 865664 D01v01r04 (See Table 4-1) and IEEE 1528-2013.
2. The point SAR measurement was taken at the maximum SAR region determined from Step 1 to enable the monitoring of SAR fluctuations/drifts during the 1g/10g cube evaluation. SAR at this fixed point was measured and used as a reference value.
3. Based on the area scan data, the peak of the region with maximum SAR was determined by spline interpolation. Around this point, a volume was assessed according to the measurement resolution and volume size requirements of FCC KDB Publication 865664 D01v01r04 (See Table 4-1) and IEEE 1528-2013. On the basis of this data set, the spatial peak SAR value was evaluated with the following procedure (see references or the DASY manual online for more details):
 - a. SAR values at the inner surface of the phantom are extrapolated from the measured values along the line away from the surface with spacing no greater than that in Table 4-1. The extrapolation was based on a least-squares algorithm. A polynomial of the fourth order was calculated through the points in the z-axis (normal to the phantom shell).
 - b. After the maximum interpolated values were calculated between the points in the cube, the SAR was averaged over the spatial volume (1g or 10g) using a 3D-Spline interpolation algorithm. The 3D-spline is composed of three one-dimensional splines with the “Not a knot” condition (in x, y, and z directions). The volume was then integrated with the trapezoidal algorithm. One thousand points (10 x 10 x 10) were obtained through interpolation, in order to calculate the averaged SAR.
 - c. All neighboring volumes were evaluated until no neighboring volume with a higher average value was found.
4. The SAR reference value, at the same location as step 2, was re-measured after the zoom scan was complete to calculate the SAR drift. If the drift deviated by more than 5%, the SAR test and drift measurements were repeated.

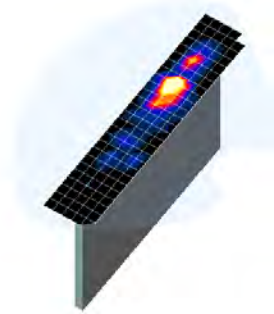



Figure 4-1
Sample SAR Area Scan

Table 4-1
Area and Zoom Scan Resolutions per FCC KDB Publication 865664 D01v01r04*

Frequency	Maximum Area Scan Resolution (mm) ($\Delta x_{area}, \Delta y_{area}$)	Maximum Zoom Scan Resolution (mm) ($\Delta x_{zoom}, \Delta y_{zoom}$)	Maximum Zoom Scan Spatial Resolution (mm)			Minimum Zoom Scan Volume (mm) (x,y,z)
			Uniform Grid	Graded Grid		
				$\Delta z_{zoom}(n)$	$\Delta z_{zoom}(1)^*$	
≤ 2 GHz	≤ 15	≤ 8	≤ 5	≤ 4	≤ 1.5* $\Delta z_{zoom}(n-1)$	≥ 30
2-3 GHz	≤ 12	≤ 5	≤ 5	≤ 4	≤ 1.5* $\Delta z_{zoom}(n-1)$	≥ 30
3-4 GHz	≤ 12	≤ 5	≤ 4	≤ 3	≤ 1.5* $\Delta z_{zoom}(n-1)$	≥ 28
4-5 GHz	≤ 10	≤ 4	≤ 3	≤ 2.5	≤ 1.5* $\Delta z_{zoom}(n-1)$	≥ 25
5-6 GHz	≤ 10	≤ 4	≤ 2	≤ 2	≤ 1.5* $\Delta z_{zoom}(n-1)$	≥ 22

*Also compliant to IEEE 1528-2013 Table 6

FCC ID: A3LSMT867U		SAR EVALUATION REPORT		Approved by: Quality Manager
Document S/N: 1M1907300131-01-R1.A3L	Test Dates: 08/05/19 - 08/27/19	DUT Type: Portable Tablet		Page 13 of 126

5 TEST CONFIGURATION POSITIONS

5.1 Device Holder

The device holder is made out of low-loss POM material having the following dielectric parameters: relative permittivity $\epsilon = 3$ and loss tangent $\delta = 0.02$.

5.2 SAR Testing for Tablet per KDB Publication 616217 D04v01r02



Per FCC KDB Publication 616217 D04v01r02, the back surface and edges of the tablet should be tested for SAR compliance with the tablet touching the phantom. The SAR Exclusion Threshold in KDB 447498 D01v06 can be applied to determine SAR test exclusion for adjacent edge configurations. The closest distance from the antenna to an adjacent tablet edge is used to determine if SAR testing is required for the adjacent edges, with the adjacent edge positioned against the phantom and the edge containing the antenna positioned perpendicular to the phantom.

5.3 Proximity Sensor Considerations

This device uses a power reduction mechanism to reduce output powers in certain use conditions when the device is used close the user's body.

When the device's antenna is within a certain distance of the user, the sensor activates and reduces the maximum allowed output power. However, the sensor is not active when the device is moved beyond the sensor triggering distance and the maximum output power is no longer limited. Therefore, additional evaluation is needed in the vicinity of the triggering distance to ensure SAR is compliant when the device is allowed to operate at a non-reduced output power level. FCC KDB Publication 616217 D04v01r02 Section 6 was used as a guideline for selecting SAR test distances for this device at these additional test positions. Sensor triggering distance summary data is included in Appendix G.

The sensor is designed to support sufficient detection range and sensitivity to cover regions of the sensors in all applicable directions since the sensor entirely covers the antennas.

FCC ID: A3LSMT867U	 PCTEST ENGINEERING LABORATORY, INC.	SAR EVALUATION REPORT	 SAMSUNG	Approved by: Quality Manager
Document S/N: 1M1907300131-01-R1.A3L	Test Dates: 08/05/19 - 08/27/19	DUT Type: Portable Tablet	Page 14 of 126	

6 RF EXPOSURE LIMITS

6.1 Uncontrolled Environment

UNCONTROLLED ENVIRONMENTS are defined as locations where there is the exposure of individuals who have no knowledge or control of their exposure. The general population/uncontrolled exposure limits are applicable to situations in which the general public may be exposed or in which persons who are exposed as a consequence of their employment may not be made fully aware of the potential for exposure or cannot exercise control over their exposure. Members of the general public would come under this category when exposure is not employment-related; for example, in the case of a wireless transmitter that exposes persons in its vicinity.



6.2 Controlled Environment

CONTROLLED ENVIRONMENTS are defined as locations where there is exposure that may be incurred by persons who are aware of the potential for exposure, (i.e. as a result of employment or occupation). In general, occupational/controlled exposure limits are applicable to situations in which persons are exposed as a consequence of their employment, who have been made fully aware of the potential for exposure and can exercise control over their exposure. This exposure category is also applicable when the exposure is of a transient nature due to incidental passage through a location where the exposure levels may be higher than the general population/uncontrolled limits, but the exposed person is fully aware of the potential for exposure and can exercise control over his or her exposure by leaving the area or by some other appropriate means.

Table 6-1
SAR Human Exposure Specified in ANSI/IEEE C95.1-1992 and Health Canada Safety Code 6

HUMAN EXPOSURE LIMITS		
	UNCONTROLLED ENVIRONMENT <i>General Population</i> (W/kg) or (mW/g)	CONTROLLED ENVIRONMENT <i>Occupational</i> (W/kg) or (mW/g)
Peak Spatial Average SAR Head	1.6	8.0
Whole Body SAR	0.08	0.4
Peak Spatial Average SAR Hands, Feet, Ankle, Wrists, etc.	4.0	20

1. The Spatial Peak value of the SAR averaged over any 1 gram of tissue (defined as a tissue volume in the shape of a cube) and over the appropriate averaging time.
2. The Spatial Average value of the SAR averaged over the whole body.
3. The Spatial Peak value of the SAR averaged over any 10 grams of tissue (defined as a tissue volume in the shape of a cube) and over the appropriate averaging time.

FCC ID: A3LSMT867U	 PCTEST ENGINEERING LABORATORY, INC.	SAR EVALUATION REPORT		Approved by: Quality Manager
Document S/N: 1M1907300131-01-R1.A3L	Test Dates: 08/05/19 - 08/27/19	DUT Type: Portable Tablet		Page 15 of 126

7 FCC MEASUREMENT PROCEDURES

Power measurements for licensed transmitters are performed using a base station simulator under digital average power.

7.1 Measured and Reported SAR

Per FCC KDB Publication 447498 D01v06, when SAR is not measured at the maximum power level allowed for production units, the results must be scaled to the maximum tune-up tolerance limit according to the power applied to the individual channels tested to determine compliance. For simultaneous transmission, the measured aggregate SAR must be scaled according to the sum of the differences between the maximum tune-up tolerance and actual power used to test each transmitter. When SAR is measured at or scaled to the maximum tune-up tolerance limit, the results are referred to as *reported* SAR. The highest *reported* SAR results are identified on the grant of equipment authorization according to procedures in KDB 690783 D01v01r03.

7.2 3G SAR Test Reduction Procedure

In FCC KDB Publication 941225 D01v03r01, certain transmission modes within a frequency band and wireless mode evaluated for SAR are defined as primary modes. The equivalent modes considered for SAR test reduction are denoted as secondary modes. When the maximum output power including tune-up tolerance specified for production units in a secondary mode is ≤ 0.25 dB higher than the primary mode or when the highest reported SAR of the primary mode, scaled by the ratio of specified maximum output power and tune-up tolerance of secondary to primary mode, is ≤ 1.2 W/kg, SAR measurements are not required for the secondary mode. These criteria are referred to as the 3G SAR test reduction procedure. When the 3G SAR test reduction procedure is not satisfied, SAR measurements are additionally required for the secondary mode.

7.3 Procedures Used to Establish RF Signal for SAR



The following procedures are according to FCC KDB Publication 941225 D01v03r01 “3G SAR Measurement Procedures.”

The device is placed into a simulated call using a base station simulator in a RF shielded chamber. Establishing connections in this manner ensure a consistent means for testing SAR and are recommended for evaluating SAR [4]. Devices under test are evaluated prior to testing, with a fully charged battery and were configured to operate at maximum output power. In order to verify that the device is tested throughout the SAR test at maximum output power, the SAR measurement system measures a “point SAR” at an arbitrary reference point at the start and end of the 1 gram SAR evaluation, to assess for any power drifts during the evaluation. If the power drift deviates by more than 5%, the SAR test and drift measurements are repeated.

7.4 SAR Measurement Conditions for UMTS

7.4.1 Output Power Verification

Maximum output power is verified on the High, Middle and Low channels according to the general descriptions in section 5.2 of 3GPP TS 34.121, using the appropriate RMC with TPC (transmit power control) set to all “1s” or applying the required inner loop power control procedures to maintain maximum output power while HSUPA is active. Results for all applicable physical channel configurations (DPCCH, DPDCHn and spreading codes, HS-DPCCH etc) are tabulated in this test report. All configurations that are not supported by the DUT or cannot be measured due to technical or equipment limitations are identified.

FCC ID: A3LSMT867U		SAR EVALUATION REPORT		Approved by: Quality Manager
Document S/N: 1M1907300131-01-R1.A3L	Test Dates: 08/05/19 - 08/27/19	DUT Type: Portable Tablet		Page 16 of 126

7.4.2 Body SAR Measurements

SAR for body exposure configurations is measured using the 12.2 kbps RMC with the TPC bits all “1s”. The 3G SAR test reduction procedure is applied to other spreading codes and multiple DPDCH_n configurations supported by the handset with 12.2 kbps RMC as the primary mode. Otherwise, SAR is measured using an applicable RMC configuration with the corresponding spreading code or DPDCH_n, for the highest reported SAR configuration in 12.2 kbps RMC.

7.4.3 SAR Measurements with Rel 5 HSDPA

The 3G SAR test reduction procedure is applied to HSDPA body configurations with 12.2 kbps RMC as the primary mode. Otherwise, Body SAR for HSDPA is measured using an FRC with H-Set 1 in Sub-test 1 and a 12.2 kbps RMC configured in Test Loop Mode 1, for the highest reported SAR configuration in 12.2 kbps RMC without HSDPA. Handsets with both HSDPA and HSUPA are tested according to Release 6 HSPA test procedures.

7.4.4 SAR Measurements with Rel 6 HSUPA

The 3G SAR test reduction procedure is applied to HSPA (HSUPA/HSDPA with RMC) body configurations with 12.2 kbps RMC as the primary mode. Otherwise, Body SAR for HSPA is measured with E-DCH Sub-test 5, using H-Set 1 and QPSK for FRC and a 12.2 kbps RMC configured in Test Loop Mode 1 and power control algorithm 2, according to the highest reported body SAR configuration in 12.2 kbps RMC without HSPA.

When VOIP applies to head exposure, the 3G SAR test reduction procedure is applied with 12.2 kbps RMC as the primary mode; otherwise, the same HSPA configuration used for body SAR measurements are applied to head exposure testing.

7.4.5 SAR Measurement Conditions for DC-HSDPA

SAR is required for Rel. 8 DC-HSDPA when SAR is required for Rel. 5 HSDPA; otherwise, the 3G SAR test reduction procedure is applied to DC-HSDPA with 12.2 kbps RMC as the primary mode. Power is measured for DC-HSDPA according to the H-Set 12, FRC configuration in Table C.8.1.12 of 3GPP TS 34.121-1 to determine SAR test reduction. A primary and a secondary serving HS-DSCH Cell are required to perform the power measurement and for the results to be acceptable.

7.5 SAR Measurement Conditions for LTE



LTE modes are tested according to FCC KDB 941225 D05v02r04 publication. Establishing connections with base station simulators ensure a consistent means for testing SAR and are recommended for evaluating SAR [4]. The R&S CMW500 or Anritsu MT8820C simulators are used for LTE output power measurements and SAR testing. Closed loop power control was used so the UE transmits with maximum output power during SAR testing. SAR tests were performed with the same number of RB and RB offsets transmitting on all TTI frames (maximum TTI).

7.5.1 Spectrum Plots for RB Configurations

A properly configured base station simulator was used for SAR tests and power measurements. Therefore, spectrum plots for RB configurations were not required to be included in this report.

7.5.2 MPR

MPR is permanently implemented for this device by the manufacturer. The specific manufacturer target MPR is indicated alongside the SAR results. MPR is enabled for this device, according to 3GPP TS36.101 Section 6.2.3 – 6.2.5 under Table 6.2.3-1.

FCC ID: A3LSMT867U	 PCTEST ENGINEERING LABORATORY, INC.	SAR EVALUATION REPORT		Approved by: Quality Manager
Document S/N: 1M1907300131-01-R1.A3L	Test Dates: 08/05/19 - 08/27/19	DUT Type: Portable Tablet		Page 17 of 126

7.5.3 A-MPR

A-MPR (Additional MPR) has been disabled for all SAR tests by setting NS=01 on the base station simulator.

7.5.4 Required RB Size and RB Offsets for SAR Testing

According to FCC KDB 941225 D05v02r04:



- a. Per Section 5.2.1, SAR is required for QPSK 1 RB Allocation for the largest bandwidth
 - i. The required channel and offset combination with the highest maximum output power is required for SAR.
 - ii. When the reported SAR is ≤ 0.8 W/kg, testing of the remaining RB offset configurations and required test channels is not required. Otherwise, SAR is required for the remaining required test channels using the RB offset configuration with highest output power for that channel.
 - iii. When the reported SAR for a required test channel is > 1.45 W/kg, SAR is required for all RB offset configurations for that channel.
- b. Per Section 5.2.2, SAR is required for 50% RB allocation using the largest bandwidth following the same procedures outlined in Section 5.2.1.
- c. Per Section 5.2.3, QPSK SAR is not required for the 100% allocation when the highest maximum output power for the 100% allocation is less than the highest maximum output power of the 1 RB and 50% RB allocations and the reported SAR for the 1 RB and 50% RB allocations is < 0.8 W/kg.
- d. Per Section 5.2.4 and 5.3, SAR tests for higher order modulations and lower bandwidths configurations are not required when the conducted power of the required test configurations determined by Sections 5.2.1 through 5.2.3 is less than or equal to $\frac{1}{2}$ dB higher than the equivalent configuration using QPSK modulation and when the QPSK SAR for those configurations is < 1.45 W/kg.

7.5.5 TDD

LTE TDD testing is performed using the SAR test guidance provided in FCC KDB 941225 D05v02r04. TDD is tested at the highest duty factor using UL-DL configuration 0 with special subframe configuration 6 and applying the FDD LTE procedures in KDB 941225 D05v02r04. SAR testing is performed using the extended cyclic prefix listed in 3GPP TS 36.211 Section 4.

7.5.6 Downlink Only Carrier Aggregation

Conducted power measurements with LTE Carrier Aggregation (CA) (downlink only) active are made in accordance to KDB Publication 941225 D05Av01r02. The RRC connection is only handled by one cell, the primary component carrier (PCC) for downlink and uplink communications. After making a data connection to the PCC, the UE device adds secondary component carrier(s) (SCC) on the downlink only. All uplink communications and acknowledgements remain identical to specifications when downlink carrier aggregation is inactive on the PCC. Additional conducted output powers are measured with the downlink carrier aggregation active for the configuration with highest measured maximum conducted power with downlink carrier aggregation inactive measured among the channel bandwidth, modulation, and RB combinations in each frequency band. Per FCC KDB Publication 941225 D05Av01r02, no SAR measurements are required for downlink only carrier aggregation configurations when the average output power with downlink only carrier aggregation active is not more than 0.25 dB higher than the average output power with downlink only carrier aggregation inactive.

FCC ID: A3LSMT867U	 PCTEST ENGINEERING LABORATORY, INC.	SAR EVALUATION REPORT		Approved by: Quality Manager
Document S/N: 1M1907300131-01-R1.A3L	Test Dates: 08/05/19 - 08/27/19	DUT Type: Portable Tablet		Page 18 of 126

7.6 SAR Testing with 802.11 Transmitters

The normal network operating configurations of 802.11 transmitters are not suitable for SAR measurements. Unpredictable fluctuations in network traffic and antenna diversity conditions can introduce undesirable variations in SAR results. The SAR for these devices should be measured using chipset based test mode software to ensure the results are consistent and reliable. See KDB Publication 248227 D01v02r02 for more details.

7.6.1 General Device Setup

Chipset based test mode software is hardware dependent and generally varies among manufacturers. The device operating parameters established in test mode for SAR measurements must be identical to those programmed in production units, including output power levels, amplifier gain settings and other RF performance tuning parameters.

A periodic duty factor is required for current generation SAR systems to measure SAR. When 802.11 frame gaps are accounted for in the transmission, a maximum transmission duty factor of 92 - 96% is typically achievable in most test mode configurations. A minimum transmission duty factor of 85% is required to avoid certain hardware and device implementation issues related to wide range SAR scaling. The reported SAR is scaled to 100% transmission duty factor to determine compliance at the maximum tune-up tolerance limit.

7.6.2 U-NII-1 and U-NII-2A

For devices that operate in both U-NII-1 and U-NII-2A bands, when the same maximum output power is specified for both bands, SAR measurement using OFDM SAR test procedures is not required for U-NII-1 unless the highest reported SAR for U-NII-2A is > 1.2 W/kg. When different maximum output powers are specified for the bands, SAR measurement for the U-NII band with the lower maximum output power is not required unless the highest reported SAR for the U-NII band with the higher maximum output power, adjusted by the ratio of lower to higher specified maximum output power for the two bands, is > 1.2 W/kg.



7.6.3 U-NII-2C and U-NII-3

The frequency range covered by U-NII-2C and U-NII-3 is 380 MHz (5.47 – 5.85 GHz), which requires a minimum of at least two SAR probe calibration frequency points to support SAR measurements. When Terminal Doppler Weather Radar (TDWR) restriction applies, the channels at 5.60 – 5.65 GHz in U-NII-2C band must be disabled with acceptable mechanisms and documented in the equipment certification. Unless band gap channels are permanently disabled, SAR must be considered for these channels. Each band is tested independently according to the normally required OFDM SAR measurement and probe calibration frequency points requirements.

7.6.4 2.4 GHz SAR Test Requirements

SAR is measured for 2.4 GHz 802.11b DSSS using either the fixed test position or, when applicable, the initial test position procedure. SAR test reduction is determined according to the following:

- 1) When the reported SAR of the highest measured maximum output power channel for the exposure configuration is ≤ 0.8 W/kg, no further SAR testing is required for 802.11b DSSS in that exposure configuration.
- 2) When the reported SAR is > 0.8 W/kg, SAR is required for that position using the next highest measured output power channel. When any reported SAR is > 1.2 W/kg, SAR is required for the third channel; i.e., all channels require testing.

FCC ID: A3LSMT867U	 PCTEST Engineering Laboratory, Inc.	SAR EVALUATION REPORT		Approved by: Quality Manager
Document S/N: 1M1907300131-01-R1.A3L	Test Dates: 08/05/19 - 08/27/19	DUT Type: Portable Tablet	Page 19 of 126	

2.4 GHz 802.11 g/n OFDM are additionally evaluated for SAR if the highest reported SAR for 802.11b, adjusted by the ratio of the OFDM to DSSS specified maximum output power, is > 1.2 W/kg. When SAR is required for OFDM modes in 2.4 GHz band, the Initial Test Configuration Procedures should be followed.

7.6.5 OFDM Transmission Mode and SAR Test Channel Selection

When the same maximum output power was specified for multiple OFDM transmission mode configurations in a frequency band or aggregated band, SAR is measured using the configuration with the largest channel bandwidth, lowest order modulation and lowest data rate. When the maximum output power of a channel is the same for equivalent OFDM configurations; for example, 802.11a, 802.11n and 802.11ac or 802.11g and 802.11n with the same channel bandwidth, modulation and data rate etc., the lower order 802.11 mode i.e., 802.11a, then 802.11n and 802.11ac or 802.11g then 802.11n, is used for SAR measurement. When the maximum output power are the same for multiple test channels, either according to the default or additional power measurement requirements, SAR is measured using the channel closest to the middle of the frequency band or aggregated band. When there are multiple channels with the same maximum output power, SAR is measured using the higher number channel.

7.6.6 Initial Test Configuration Procedure

For OFDM, an initial test configuration is determined for each frequency band and aggregated band, according to the transmission mode with the highest maximum output power specified for SAR measurements. When the same maximum output power is specified for multiple OFDM transmission mode configurations in a frequency band or aggregated band, SAR is measured using the configuration(s) with the largest channel bandwidth, lowest order modulation, lowest data rate and lowest order IEEE 802.11 mode. The channel of the transmission mode with the highest average RF output conducted power will be the initial test configuration.



When the reported SAR is ≤ 0.8 W/kg, no additional measurements on other test channels are required. Otherwise, SAR is evaluated using the subsequent highest average RF output channel until the reported SAR result is ≤ 1.2 W/kg or all channels are measured. When there are multiple untested channels having the same subsequent highest average RF output power, the channel with higher frequency from the lowest 802.11 mode is considered for SAR measurements (See Section 7.6.5).

7.6.7 Subsequent Test Configuration Procedures

For OFDM configurations in each frequency band and aggregated band, SAR is evaluated for initial test configuration using the fixed test position or the initial test position procedure. When the highest reported SAR (for the initial test configuration), adjusted by the ratio of the specified maximum output power of the subsequent test configuration to initial test configuration, is ≤ 1.2 W/kg, no additional SAR tests for the subsequent test configurations are required.

7.6.8 MIMO SAR considerations

Per KDB Publication 248227 D01v02r02, the simultaneous SAR provisions in KDB Publication 447498 D01v06 should be applied to determine simultaneous transmission SAR test exclusion for WIFI MIMO. If the sum of 1g single transmission chain SAR measurements is < 1.6 W/kg, no additional SAR measurements for MIMO are required. Alternatively, SAR for MIMO can be measured with all antennas transmitting simultaneously at the specified maximum output power of MIMO operation.

FCC ID: A3LSMT867U		SAR EVALUATION REPORT		Approved by: Quality Manager
Document S/N: 1M1907300131-01-R1.A3L	Test Dates: 08/05/19 - 08/27/19	DUT Type: Portable Tablet	Page 20 of 126	

8 RF CONDUCTED POWERS

8.1 UMTS Conducted Powers

**Table 8-1
Maximum Conducted Power**

3GPP Release Version	Mode	3GPP 34.121 Subtest	Cellular Band [dBm]			AWS Band [dBm]			PCS Band [dBm]			3GPP MPR [dB]
			4132	4183	4233	1312	1412	1513	9262	9400	9538	
99	WCDMA	12.2 kbps RMC	24.06	24.14	24.28	24.74	24.91	24.77	23.45	23.58	23.59	-
6	HSDPA	Subtest 1	22.96	23.09	23.32	23.80	24.00	23.89	22.44	22.53	22.58	0
6		Subtest 2	22.93	22.99	23.26	23.83	23.98	23.65	22.38	22.59	22.64	0
6		Subtest 3	22.46	22.50	22.77	23.13	23.49	23.43	21.89	22.07	22.06	0.5
6		Subtest 4	22.48	22.28	22.71	23.13	23.50	23.41	21.92	22.04	22.05	0.5
6	HSUPA	Subtest 1	22.95	23.05	23.29	23.84	23.97	23.95	22.47	22.59	22.68	0
6		Subtest 2	20.97	20.99	21.05	21.77	22.00	21.88	20.45	20.49	20.64	2
6		Subtest 3	21.93	22.05	22.27	22.80	22.89	22.87	21.47	21.52	21.63	1
6		Subtest 4	20.98	21.00	21.06	21.78	22.00	21.88	20.48	20.51	20.65	2
6		Subtest 5	23.03	23.14	23.30	23.88	24.00	23.91	22.59	22.67	22.70	0
8	DC-HSDPA	Subtest 1	23.02	23.13	23.34	23.86	23.99	23.83	22.51	22.60	22.69	0
8		Subtest 2	22.95	22.92	22.89	23.86	24.00	23.98	22.56	22.62	22.67	0
8		Subtest 3	22.48	22.42	22.54	23.35	23.50	23.49	22.03	22.08	22.16	0.5
8		Subtest 4	22.55	22.32	22.51	23.38	23.42	23.49	22.01	22.03	22.08	0.5

**Table 8-2
Reduced Conducted Power**

3GPP Release Version	Mode	3GPP 34.121 Subtest	Cellular Band [dBm]			AWS Band [dBm]			PCS Band [dBm]			3GPP MPR [dB]
			4132	4183	4233	1312	1412	1513	9262	9400	9538	
99	WCDMA	12.2 kbps RMC	17.58	17.69	17.80	13.77	13.96	13.73	13.97	13.94	14.00	-
6	HSDPA	Subtest 1	16.61	16.71	16.86	12.90	13.02	12.85	13.11	13.09	13.21	0
6		Subtest 2	16.50	16.65	16.80	12.89	13.16	12.95	13.12	13.06	13.23	0
6		Subtest 3	16.05	16.22	16.19	12.27	12.67	12.25	12.63	12.58	12.67	0.5
6		Subtest 4	16.10	16.26	16.14	12.37	12.64	12.38	12.62	12.60	12.65	0.5
6	HSUPA	Subtest 1	16.58	16.68	16.80	12.91	13.10	12.97	13.54	13.51	13.59	0
6		Subtest 2	14.57	14.67	14.81	10.87	11.07	10.93	11.59	11.57	11.54	2
6		Subtest 3	15.60	15.71	15.82	11.87	12.02	11.94	12.40	12.48	12.66	1
6		Subtest 4	14.58	14.68	14.78	10.85	11.07	10.92	11.52	11.43	11.52	2
6		Subtest 5	16.62	16.76	16.84	12.96	13.15	12.96	13.57	13.58	13.65	0
8	DC-HSDPA	Subtest 1	16.60	16.68	16.81	12.87	13.01	12.84	13.08	13.08	13.17	0
8		Subtest 2	16.49	16.64	16.78	12.88	13.16	12.99	13.12	13.05	13.21	0
8		Subtest 3	16.01	16.18	16.11	12.35	12.69	12.24	12.66	12.58	12.67	0.5
8		Subtest 4	16.02	16.25	16.12	12.36	12.70	12.40	12.60	12.47	12.64	0.5

DC-HSDPA considerations

- 3GPP Specification 34.121-1 Release 8 Ver 8.10.0 was used for DC-HSDPA guidance
- H-Set 12 (QPSK) was confirmed to be used during DC-HSDPA measurements
- The DUT supports UE category 24 for HSDPA

It is expected by the manufacturer that MPR for some HSPA subtests may be up to 2 dB more than specified by 3GPP, but also as low as 0 dB according to the chipset implementation in this model.



**Figure 8-1
Power Measurement Setup**

FCC ID: A3LSMT867U		SAR EVALUATION REPORT		Approved by: Quality Manager
Document S/N: 1M1907300131-01-R1.A3L	Test Dates: 08/05/19 - 08/27/19	DUT Type: Portable Tablet	Page 21 of 126	

8.2 LTE Conducted Powers

8.2.1 LTE Band 71

Table 8-3
LTE Band 71 Maximum Conducted Powers - 20 MHz Bandwidth



LTE Band 71 20 MHz Bandwidth					
Modulation	RB Size	RB Offset	Mid Channel	MPR Allowed per 3GPP [dB]	MPR [dB]
			133297 (680.5 MHz) Conducted Power [dBm]		
QPSK	1	0	25.14	0	0
	1	50	25.05		0
	1	99	24.75		0
	50	0	24.18	0-1	1
	50	25	24.21		1
	50	50	24.11		1
	100	0	24.17		1
16QAM	1	0	24.38	0-1	1
	1	50	24.29		1
	1	99	23.94		1
	50	0	23.14	0-2	2
	50	25	23.21		2
	50	50	23.08		2
	100	0	23.16		2
64QAM	1	0	23.37	0-2	2
	1	50	23.28		2
	1	99	22.93		2
	50	0	22.16	0-3	3
	50	25	22.22		3
	50	50	22.11		3
	100	0	22.17		3

Note: LTE Band 71 at 20 MHz bandwidth does not support three non-overlapping channels. Per KDB Publication 941225 D05v02, when a device supports overlapping channel assignment in a channel bandwidth configuration, the middle channel of the group of overlapping channels should be selected for testing.

Table 8-4
LTE Band 71 Maximum Conducted Powers - 15 MHz Bandwidth

LTE Band 71 15 MHz Bandwidth					
Modulation	RB Size	RB Offset	Mid Channel	MPR Allowed per 3GPP [dB]	MPR [dB]
			133297 (680.5 MHz) Conducted Power [dBm]		
QPSK	1	0	25.15	0	0
	1	36	25.02		0
	1	74	24.82		0
	36	0	24.21	0-1	1
	36	18	24.22		1
	36	37	24.15		1
	75	0	24.13		1
16QAM	1	0	24.33	0-1	1
	1	36	24.25		1
	1	74	24.10		1
	36	0	23.19	0-2	2
	36	18	23.18		2
	36	37	23.10		2
	75	0	23.15		2
64QAM	1	0	23.26	0-2	2
	1	36	23.21		2
	1	74	23.00		2
	36	0	22.20	0-3	3
	36	18	22.20		3
	36	37	22.13		3
	75	0	22.15		3

Note: LTE Band 71 at 15 MHz bandwidth does not support three non-overlapping channels. Per KDB Publication 941225 D05v02, when a device supports overlapping channel assignment in a channel bandwidth configuration, the middle channel of the group of overlapping channels should be selected for testing.

FCC ID: A3LSMT867U		SAR EVALUATION REPORT		Approved by: Quality Manager
Document S/N: 1M1907300131-01-R1.A3L	Test Dates: 08/05/19 - 08/27/19	DUT Type: Portable Tablet		Page 22 of 126

**Table 8-5
LTE Band 71 Maximum Conducted Powers - 10 MHz Bandwidth**

LTE Band 71 10 MHz Bandwidth								
Modulation	RB Size	RB Offset	Low Channel	Mid Channel	High Channel	MPR Allowed per 3GPP [dB]	MPR [dB]	
			133172 (668.0 MHz)	133297 (680.5 MHz)	133422 (693.0 MHz)			
			Conducted Power [dBm]					
QPSK	1	0	24.95	24.97	24.74	0	0	
	1	25	24.95	25.00	24.62		0	
	1	49	24.95	24.82	24.50		0	
	25	0	24.05	24.05	23.77	0-1	1	
	25	12	24.07	24.08	23.77		1	
	25	25	24.05	23.99	23.73		1	
16QAM	50	0	24.07	24.05	23.74	0-1	1	
	1	0	24.15	24.25	23.93		0-1	1
	1	25	24.15	24.12	23.92			1
	1	49	24.18	24.08	23.65	0-2		1
	25	0	23.04	23.05	22.73		2	
	25	12	23.04	23.05	22.75		2	
64QAM	25	25	22.98	22.97	22.68	0-2	2	
	50	0	23.02	23.02	22.71		2	
	1	0	23.18	23.15	22.83		0-2	2
	1	25	23.15	23.20	22.60	2		
	1	49	23.05	23.00	22.63	2		
	64QAM	25	0	22.06	22.08	21.75	0-3	3
25		12	22.08	22.09	21.75	3		
25		25	22.03	22.03	21.68	3		
50		0	22.04	22.06	21.73	3		

**Table 8-6
LTE Band 71 Maximum Conducted Powers - 5 MHz Bandwidth**

LTE Band 71 5 MHz Bandwidth								
Modulation	RB Size	RB Offset	Low Channel	Mid Channel	High Channel	MPR Allowed per 3GPP [dB]	MPR [dB]	
			133147 (665.5 MHz)	133297 (680.5 MHz)	133447 (695.5 MHz)			
			Conducted Power [dBm]					
QPSK	1	0	24.58	24.87	24.61	0	0	
	1	12	24.59	25.00	24.60		0	
	1	24	24.56	24.92	24.56		0	
	12	0	23.72	24.00	23.70	0-1	1	
	12	6	23.75	24.04	23.75		1	
	12	13	23.71	24.06	23.70		1	
16QAM	25	0	23.69	24.05	23.70	0-1	1	
	1	0	23.83	24.15	23.83		0-1	1
	1	12	23.85	24.23	23.86			1
	1	24	23.74	24.20	23.77	0-2		1
	12	0	22.70	23.05	22.70		2	
	12	6	22.73	23.08	22.70		2	
64QAM	12	13	22.67	23.09	22.68	0-2	2	
	25	0	22.66	23.00	22.66		2	
	1	0	22.86	23.00	22.88		0-2	2
	1	12	22.80	23.20	22.80	2		
	1	24	22.77	23.14	22.76	2		
	64QAM	12	0	21.72	22.04	21.72	0-3	3
12		6	21.77	22.08	21.75	3		
12		13	21.70	22.07	21.70	3		
25		0	21.70	22.05	21.70	3		



FCC ID: A3LSMT867U		SAR EVALUATION REPORT		Approved by: Quality Manager
Document S/N: 1M1907300131-01-R1.A3L	Test Dates: 08/05/19 - 08/27/19	DUT Type: Portable Tablet	Page 23 of 126	

Table 8-7
LTE Band 71 Reduced Conducted Powers - 20 MHz Bandwidth

LTE Band 71 20 MHz Bandwidth					
Modulation	RB Size	RB Offset	Mid Channel	MPR Allowed per 3GPP [dB]	MPR [dB]
			133297 (680.5 MHz)		
			Conducted Power [dBm]		
QPSK	1	0	17.24	0	0
	1	50	17.12		0
	1	99	16.93		0
	50	0	17.31	0-1	0
	50	25	17.30		0
	50	50	17.23		0
16QAM	100	0	17.23	0-1	0
	1	0	17.50		0
	1	50	17.43		0
	1	99	17.19	0-2	0
	50	0	17.28		0
	50	25	17.29		0
64QAM	50	50	17.32	0-2	0
	100	0	17.34		0
	1	0	17.45		0-3
	1	50	17.44	0	
	1	99	17.26	0	
	50	0	17.33	0	
50	25	17.33	0		
50	50	17.22	0		
100	0	17.31	0		

Note: LTE Band 71 at 20 MHz bandwidth does not support three non-overlapping channels. Per KDB Publication 941225 D05v02, when a device supports overlapping channel assignment in a channel bandwidth configuration, the middle channel of the group of overlapping channels should be selected for testing.

Table 8-8
LTE Band 71 Reduced Conducted Powers - 15 MHz Bandwidth

LTE Band 71 15 MHz Bandwidth					
Modulation	RB Size	RB Offset	Mid Channel	MPR Allowed per 3GPP [dB]	MPR [dB]
			133297 (680.5 MHz)		
			Conducted Power [dBm]		
QPSK	1	0	17.11	0	0
	1	36	17.02		0
	1	74	16.93		0
	36	0	17.26	0-1	0
	36	18	17.23		0
	36	37	17.20		0
	75	0	17.19		0
16QAM	1	0	17.35	0-1	0
	1	36	17.18		0
	1	74	17.03		0
	36	0	17.19	0-2	0
	36	18	17.14		0
	36	37	17.15		0
	75	0	17.10		0
64QAM	1	0	17.36	0-2	0
	1	36	17.05		0
	1	74	16.99		0
	36	0	17.26	0-3	0
	36	18	17.31		0
	36	37	17.24		0
	75	0	17.26		0

Note: LTE Band 71 at 15 MHz bandwidth does not support three non-overlapping channels. Per KDB Publication 941225 D05v02, when a device supports overlapping channel assignment in a channel bandwidth configuration, the middle channel of the group of overlapping channels should be selected for testing.





FCC ID: A3LSMT867U		SAR EVALUATION REPORT		Approved by: Quality Manager
Document S/N: 1M1907300131-01-R1.A3L	Test Dates: 08/05/19 - 08/27/19	DUT Type: Portable Tablet	Page 24 of 126	

Table 8-9
LTE Band 71 Reduced Conducted Powers - 10 MHz Bandwidth

LTE Band 71 10 MHz Bandwidth							
Modulation	RB Size	RB Offset	Low Channel	Mid Channel	High Channel	MPR Allowed per 3GPP [dB]	MPR [dB]
			133172 (668.0 MHz)	133297 (680.5 MHz)	133422 (693.0 MHz)		
			Conducted Power [dBm]				
QPSK	1	0	16.94	17.00	16.81	0	0
	1	25	17.02	16.97	16.73		0
	1	49	16.90	17.00	16.69		0
	25	0	17.10	17.11	16.86	0-1	0
	25	12	17.04	17.16	16.85		0
	25	25	17.07	17.06	16.82		0
16QAM	50	0	17.08	17.02	16.81	0-1	0
	1	0	17.13	17.16	17.04		0
	1	25	17.30	17.22	16.85		0
	1	49	17.21	17.14	16.81	0-2	0
	25	0	17.03	17.16	16.85		0
	25	12	17.08	17.09	16.82		0
64QAM	25	25	17.06	17.03	16.80	0-2	0
	50	0	17.04	17.06	16.82		0
	1	0	17.06	17.19	16.93		0-3
	1	25	17.05	17.25	17.00	0	
	1	49	17.12	17.05	16.81	0	
	25	0	17.10	17.07	16.82	0-3	0
25	12	17.11	17.10	16.85	0		
25	25	17.13	17.06	16.82	0		
50	0	17.06	17.08	16.83	0		

Table 8-10
LTE Band 71 Reduced Conducted Powers - 5 MHz Bandwidth

LTE Band 71 5 MHz Bandwidth							
Modulation	RB Size	RB Offset	Low Channel	Mid Channel	High Channel	MPR Allowed per 3GPP [dB]	MPR [dB]
			133147 (665.5 MHz)	133297 (680.5 MHz)	133447 (695.5 MHz)		
			Conducted Power [dBm]				
QPSK	1	0	16.87	16.88	16.52	0	0
	1	12	17.00	17.00	16.51		0
	1	24	16.98	16.98	16.50		0
	12	0	17.00	17.04	16.77	0-1	0
	12	6	17.11	17.10	16.84		0
	12	13	17.09	17.14	16.82		0
16QAM	25	0	17.07	17.09	16.82	0-1	0
	1	0	16.94	17.13	16.90		0
	1	12	16.75	17.20	16.91		0
	1	24	17.24	16.97	16.83	0-2	0
	12	0	17.00	17.08	16.82		0
	12	6	17.12	17.11	16.92		0
64QAM	12	13	17.12	17.14	16.80	0-2	0
	25	0	17.06	17.03	16.81		0
	1	0	17.13	17.08	16.95		0-3
	1	12	17.23	17.24	16.89	0	
	1	24	17.27	17.19	16.85	0	
	12	0	17.06	17.07	16.87	0-3	0
12	6	17.18	17.16	16.89	0		
12	13	17.19	17.15	16.84	0		
25	0	17.10	17.09	16.82	0		

FCC ID: A3LSMT867U		SAR EVALUATION REPORT		Approved by: Quality Manager
Document S/N: 1M1907300131-01-R1.A3L	Test Dates: 08/05/19 - 08/27/19	DUT Type: Portable Tablet	Page 25 of 126	

8.2.1

LTE Band 12

Table 8-11
LTE Band 12 Maximum Conducted Powers - 10 MHz Bandwidth

LTE Band 12 10 MHz Bandwidth					
Modulation	RB Size	RB Offset	Mid Channel	MPR Allowed per 3GPP [dB]	MPR [dB]
			23095 (707.5 MHz)		
			Conducted Power [dBm]		
QPSK	1	0	24.80	0	0
	1	25	24.70		0
	1	49	24.59		0
	25	0	23.87	0-1	1
	25	12	23.82		1
	25	25	23.78		1
16QAM	50	0	23.81	0-1	1
	1	0	24.04		1
	1	25	23.96		1
	1	49	23.82	0-2	1
	25	0	22.84		2
	25	12	22.83		2
64QAM	25	25	22.78	0-2	2
	50	0	22.82		2
	1	0	22.67		0-2
	1	25	22.71	2	
	1	49	22.45	0-3	
	25	0	21.36		3
25	12	21.46	3		
	25	25	21.50	0-3	3
	50	0	21.41		3

Note: LTE Band 12 at 10 MHz bandwidth does not support three non-overlapping channels. Per KDB Publication 941225 D05v02, when a device supports overlapping channel assignment in a channel bandwidth configuration, the middle channel of the group of overlapping channels should be selected for testing.

Table 8-12
LTE Band 12 Maximum Conducted Powers - 5 MHz Bandwidth

LTE Band 12 5 MHz Bandwidth								
Modulation	RB Size	RB Offset	Low Channel	Mid Channel	High Channel	MPR Allowed per 3GPP [dB]	MPR [dB]	
			23035 (701.5 MHz)	23095 (707.5 MHz)	23155 (713.5 MHz)			
			Conducted Power [dBm]					
QPSK	1	0	24.88	24.67	24.49	0	0	
	1	12	24.85	24.67	24.49		0	
	1	24	24.68	24.55	24.27		0	
	12	0	23.97	23.77	23.62	0-1	1	
	12	6	23.96	23.76	23.64		1	
	12	13	23.82	23.63	23.66		1	
16QAM	25	0	23.88	23.77	23.63	0-1	1	
	1	0	24.10	23.92	23.75		0-1	1
	1	12	24.08	23.90	23.80			1
	1	24	24.02	23.86	23.60	0-2		1
	12	0	23.04	22.87	22.63		2	
	12	6	22.99	22.78	22.71		2	
64QAM	12	13	22.88	22.70	22.66	0-2	2	
	25	0	22.89	22.76	22.65		2	
	1	0	22.50	22.40	22.30		0-2	2
	1	12	22.34	22.38	22.06	2		
	1	24	22.18	22.25	21.82	0-3		2
	12	0	21.38	21.35	21.08		3	
12	6	21.38	21.35	21.01	3			
	12	13	21.26	21.27	20.89	0-3	3	
	25	0	21.25	21.35	20.97		3	



FCC ID: A3LSMT867U		SAR EVALUATION REPORT		Approved by: Quality Manager
Document S/N: 1M1907300131-01-R1.A3L	Test Dates: 08/05/19 - 08/27/19	DUT Type: Portable Tablet		Page 26 of 126

Table 8-13
LTE Band 12 Maximum Conducted Powers - 3 MHz Bandwidth

LTE Band 12 3 MHz Bandwidth								
Modulation	RB Size	RB Offset	Low Channel	Mid Channel	High Channel	MPR Allowed per 3GPP [dB]	MPR [dB]	
			23025 (700.5 MHz)	23095 (707.5 MHz)	23165 (714.5 MHz)			
			Conducted Power [dBm]					
QPSK	1	0	24.89	24.64	24.42	0	0	
	1	7	24.85	24.60	24.49		0	
	1	14	24.77	24.49	24.36		0	
	8	0	23.97	23.76	23.56	0-1	1	
	8	4	23.97	23.73	23.65		1	
	8	7	23.88	23.64	23.56		1	
16QAM	15	0	24.03	23.69	23.66	0-1	1	
	1	0	24.14	23.86	23.55		0-1	1
	1	7	24.16	23.89	23.75			1
	1	14	24.00	23.80	23.60	0-2		1
	8	0	23.09	22.79	22.62		2	
	8	4	23.01	22.78	22.73		2	
64QAM	8	7	23.00	22.70	22.64	0-2	2	
	15	0	22.97	22.68	22.62		2	
	1	0	22.52	22.52	21.97		0-2	2
	1	7	22.44	22.44	22.02	2		
	1	14	22.28	22.35	21.80	0-3		2
	8	0	21.50	21.54	21.00		3	
8	4	21.53	21.41	21.05	3			
64QAM	8	7	21.36	21.31	20.85	0-3	3	
	15	0	21.37	21.38	20.90		3	

Table 8-14
LTE Band 12 Maximum Conducted Powers – 1.4 MHz Bandwidth

LTE Band 12 1.4 MHz Bandwidth								
Modulation	RB Size	RB Offset	Low Channel	Mid Channel	High Channel	MPR Allowed per 3GPP [dB]	MPR [dB]	
			23017 (699.7 MHz)	23095 (707.5 MHz)	23173 (715.3 MHz)			
			Conducted Power [dBm]					
QPSK	1	0	24.84	24.55	24.36	0	0	
	1	2	24.90	24.63	24.36		0	
	1	5	24.78	24.50	24.33		0	
	3	0	24.83	24.56	24.38		0	
	3	2	24.88	24.54	24.40		0	
	3	3	24.77	24.51	24.30		0	
16QAM	6	0	23.93	23.61	23.70	0-1	1	
	1	0	24.17	23.78	23.64		0-1	1
	1	2	24.17	23.88	23.70			1
	1	5	24.00	23.75	23.55	1		
	3	0	23.99	23.75	23.54	1		
	3	2	23.96	23.66	23.55	1		
64QAM	3	3	23.91	23.68	23.47	0-1		1
	6	0	23.05	22.70	22.55		0-2	2
	1	0	22.60	22.56	21.95			0-2
	1	2	22.65	22.66	21.80	2		
	1	5	23.00	22.48	21.74	2		
	3	0	22.58	22.45	21.90	2		
3	2	22.59	22.48	21.74	2			
3	3	22.60	22.43	21.73	2			
64QAM	6	0	21.43	21.36	20.78	0-3	3	



FCC ID: A3LSMT867U	 PCTEST ENGINEERING LABORATORY, INC.	SAR EVALUATION REPORT		Approved by: Quality Manager
Document S/N: 1M1907300131-01-R1.A3L	Test Dates: 08/05/19 - 08/27/19	DUT Type: Portable Tablet		Page 27 of 126

Table 8-15
LTE Band 12 Reduced Conducted Powers - 10 MHz Bandwidth

LTE Band 12 10 MHz Bandwidth					
Modulation	RB Size	RB Offset	Mid Channel	MPR Allowed per 3GPP [dB]	MPR [dB]
			23095 (707.5 MHz)		
			Conducted Power [dBm]		
QPSK	1	0	17.39	0	0
	1	25	17.23		0
	1	49	17.27		0
	25	0	17.46	0-1	0
	25	12	17.42		0
	25	25	17.36		0
	50	0	17.38		0
16QAM	1	0	17.58	0-1	0
	1	25	17.47		0
	1	49	17.46		0
	25	0	17.42	0-2	0
	25	12	17.38		0
	25	25	17.40		0
	50	0	17.41		0
64QAM	1	0	17.57	0-2	0
	1	25	17.41		0
	1	49	17.34		0
	25	0	17.43	0-3	0
	25	12	17.44		0
	25	25	17.39		0
	50	0	17.40		0

Note: LTE Band 12 at 10 MHz bandwidth does not support three non-overlapping channels. Per KDB Publication 941225 D05v02, when a device supports overlapping channel assignment in a channel bandwidth configuration, the middle channel of the group of overlapping channels should be selected for testing.

Table 8-16
LTE Band 12 Reduced Conducted Powers - 5 MHz Bandwidth

LTE Band 12 5 MHz Bandwidth							
Modulation	RB Size	RB Offset	Low Channel	Mid Channel	High Channel	MPR Allowed per 3GPP [dB]	MPR [dB]
			23035 (701.5 MHz)	23095 (707.5 MHz)	23155 (713.5 MHz)		
			Conducted Power [dBm]				
QPSK	1	0	17.55	17.40	17.24	0	0
	1	12	17.45	17.33	17.27		0
	1	24	17.38	17.31	17.20		0
	12	0	17.67	17.50	17.30	0-1	0
	12	6	17.60	17.43	17.36		0
	12	13	17.52	17.40	17.34		0
	25	0	17.58	17.48	17.34		0
16QAM	1	0	17.80	17.57	17.36	0-1	0
	1	12	17.73	17.61	17.13		0
	1	24	17.55	17.52	17.42		0
	12	0	17.66	17.49	17.33	0-2	0
	12	6	17.61	17.41	17.40		0
	12	13	17.50	17.34	17.33		0
	25	0	17.54	17.40	17.32		0
64QAM	1	0	17.83	17.49	17.46	0-2	0
	1	12	17.74	17.53	17.38		0
	1	24	17.58	17.45	17.43		0
	12	0	17.71	17.54	17.33	0-3	0
	12	6	17.63	17.43	17.42		0
	12	13	17.54	17.44	17.36		0
	25	0	17.60	17.43	17.35		0





FCC ID: A3LSMT867U		SAR EVALUATION REPORT		Approved by: Quality Manager
Document S/N: 1M1907300131-01-R1.A3L	Test Dates: 08/05/19 - 08/27/19	DUT Type: Portable Tablet	Page 28 of 126	

Table 8-17
LTE Band 12 Reduced Conducted Powers - 3 MHz Bandwidth

LTE Band 12 3 MHz Bandwidth							
Modulation	RB Size	RB Offset	Low Channel	Mid Channel	High Channel	MPR Allowed per 3GPP [dB]	MPR [dB]
			23025 (700.5 MHz)	23095 (707.5 MHz)	23165 (714.5 MHz)		
			Conducted Power [dBm]				
QPSK	1	0	17.53	17.38	17.16	0	0
	1	7	17.54	17.30	17.20		0
	1	14	17.40	17.21	17.18		0
	8	0	17.67	17.42	17.33	0-1	0
	8	4	17.67	17.42	17.39		0
	8	7	17.60	17.42	17.34		0
16QAM	15	0	17.67	17.42	17.34	0-1	0
	1	0	17.56	17.47	17.46		0
	1	7	17.77	17.58	17.42		0
	1	14	17.53	17.41	17.31	0-2	0
	8	0	17.68	17.47	17.30		0
	8	4	17.61	17.42	17.34		0
64QAM	8	7	17.62	17.32	17.28	0-2	0
	15	0	17.63	17.33	17.30		0
	1	0	17.82	17.52	17.35		0-2
	1	7	17.84	17.47	17.39	0	
	1	14	17.62	17.43	17.31	0	
	8	0	17.71	17.49	17.28	0-3	0
	8	4	17.67	17.50	17.44		0
	8	7	17.62	17.38	17.34		0
15	0	17.71	17.37	17.36	0		

Table 8-18
LTE Band 12 Reduced Conducted Powers – 1.4 MHz Bandwidth

LTE Band 12 1.4 MHz Bandwidth								
Modulation	RB Size	RB Offset	Low Channel	Mid Channel	High Channel	MPR Allowed per 3GPP [dB]	MPR [dB]	
			23017 (699.7 MHz)	23095 (707.5 MHz)	23173 (715.3 MHz)			
			Conducted Power [dBm]					
QPSK	1	0	17.51	17.14	17.11	0	0	
	1	2	17.59	17.16	17.21		0	
	1	5	17.44	17.01	17.15		0	
	3	0	17.53	17.12	17.13	0-1	0	
	3	2	17.56	17.08	17.25		0	
	3	3	17.45	17.03	17.14		0	
16QAM	6	0	17.61	17.32	17.23	0-1	0	
	1	0	17.52	17.48	17.25		0-1	0
	1	2	17.43	17.58	17.44			0
	1	5	17.63	17.35	17.31	0-2		0
	3	0	17.55	17.41	17.22		0	
	3	2	17.69	17.38	17.29		0	
64QAM	3	3	17.63	17.34	17.25	0-2	0	
	6	0	17.67	17.34	17.25		0	
	1	0	17.75	17.51	17.36		0-2	0
	1	2	17.80	17.52	17.45	0		
	1	5	17.63	17.39	17.35	0		
	3	0	17.68	17.42	17.28	0-3	0	
3	2	17.71	17.49	17.36	0			
3	3	17.78	17.36	17.34	0			
6	0	17.63	17.24	17.17	0			

FCC ID: A3LSMT867U		SAR EVALUATION REPORT		Approved by: Quality Manager
Document S/N: 1M1907300131-01-R1.A3L	Test Dates: 08/05/19 - 08/27/19	DUT Type: Portable Tablet		Page 29 of 126

8.2.2

LTE Band 13

Table 8-19
LTE Band 13 Maximum Conducted Powers - 10 MHz Bandwidth

LTE Band 13 10 MHz Bandwidth					
Modulation	RB Size	RB Offset	Mid Channel	MPR Allowed per 3GPP [dB]	MPR [dB]
			23230 (782.0 MHz)		
			Conducted Power [dBm]		
QPSK	1	0	24.28	0	0
	1	25	24.27		0
	1	49	24.33		0
	25	0	23.43	0-1	1
	25	12	23.41		1
	25	25	23.50		1
	50	0	23.43		1
16QAM	1	0	23.41	0-1	1
	1	25	23.43		1
	1	49	23.53		1
	25	0	22.38	0-2	2
	25	12	22.37		2
	25	25	22.42		2
	50	0	22.36		2
64QAM	1	0	22.32	0-2	2
	1	25	22.42		2
	1	49	22.53		2
	25	0	21.38	0-3	3
	25	12	21.37		3
	25	25	21.45		3
	50	0	21.39		3

Table 8-20
LTE Band 13 Maximum Conducted Powers - 5 MHz Bandwidth

LTE Band 13 5 MHz Bandwidth					
Modulation	RB Size	RB Offset	Mid Channel	MPR Allowed per 3GPP [dB]	MPR [dB]
			23230 (782.0 MHz)		
			Conducted Power [dBm]		
QPSK	1	0	24.10	0	0
	1	12	24.14		0
	1	24	24.21		0
	12	0	23.29	0-1	1
	12	6	23.27		1
	12	13	23.33		1
	25	0	23.32		1
16QAM	1	0	23.29	0-1	1
	1	12	23.33		1
	1	24	23.29		1
	12	0	22.22	0-2	2
	12	6	22.32		2
	12	13	22.33		2
	25	0	22.31		2
64QAM	1	0	22.28	0-2	2
	1	12	22.32		2
	1	24	22.27		2
	12	0	21.27	0-3	3
	12	6	21.27		3
	12	13	21.33		3
	25	0	21.32		3

Note: LTE Band 13 at 5 MHz bandwidth does not support three non-overlapping channels. Per KDB Publication 941225 D05v02, when a device supports overlapping channel assignment in a channel bandwidth configuration, the middle channel of the group of overlapping channels should be selected for testing.



FCC ID: A3LSMT867U		SAR EVALUATION REPORT		Approved by: Quality Manager
Document S/N: 1M1907300131-01-R1.A3L	Test Dates: 08/05/19 - 08/27/19	DUT Type: Portable Tablet	Page 30 of 126	



Table 8-21
LTE Band 13 Reduced Conducted Powers - 10 MHz Bandwidth

LTE Band 13 10 MHz Bandwidth					
Modulation	RB Size	RB Offset	Mid Channel	MPR Allowed per 3GPP [dB]	MPR [dB]
			23230 (782.0 MHz)		
			Conducted Power [dBm]		
QPSK	1	0	18.31	0	0
	1	25	18.29		0
	1	49	18.50		0
	25	0	18.51	0-1	0
	25	12	18.48		0
	25	25	18.58		0
	50	0	18.48		0
16QAM	1	0	18.53	0-1	0
	1	25	18.52		0
	1	49	18.58		0
	25	0	18.42	0-2	0
	25	12	18.46		0
	25	25	18.49		0
	50	0	18.44		0
64QAM	1	0	18.48	0-2	0
	1	25	18.46		0
	1	49	18.61		0
	25	0	18.48	0-3	0
	25	12	18.45		0
	25	25	18.47		0
	50	0	18.48		0

Table 8-22
LTE Band 13 Reduced Conducted Powers - 5 MHz Bandwidth

LTE Band 13 5 MHz Bandwidth					
Modulation	RB Size	RB Offset	Mid Channel	MPR Allowed per 3GPP [dB]	MPR [dB]
			23230 (782.0 MHz)		
			Conducted Power [dBm]		
QPSK	1	0	18.31	0	0
	1	12	18.36		0
	1	24	18.39		0
	12	0	18.42	0-1	0
	12	6	18.46		0
	12	13	18.51		0
	25	0	18.51		0
16QAM	1	0	18.41	0-1	0
	1	12	18.42		0
	1	24	18.50		0
	12	0	18.43	0-2	0
	12	6	18.45		0
	12	13	18.50		0
	25	0	18.50		0
64QAM	1	0	18.42	0-2	0
	1	12	18.52		0
	1	24	18.56		0
	12	0	18.43	0-3	0
	12	6	18.45		0
	12	13	18.51		0
	25	0	18.51		0

Note: LTE Band 13 at 5 MHz bandwidth does not support three non-overlapping channels. Per KDB Publication 941225 D05v02, when a device supports overlapping channel assignment in a channel bandwidth configuration, the middle channel of the group of overlapping channels should be selected for testing.

FCC ID: A3LSMT867U		SAR EVALUATION REPORT		Approved by: Quality Manager
Document S/N: 1M1907300131-01-R1.A3L	Test Dates: 08/05/19 - 08/27/19	DUT Type: Portable Tablet	Page 31 of 126	

8.2.3 LTE Band 26 (Cell)

Table 8-23
LTE Band 26 (Cell) Maximum Conducted Powers - 15 MHz Bandwidth

LTE Band 26 (Cell) 15 MHz Bandwidth					
Modulation	RB Size	RB Offset	Mid Channel	MPR Allowed per 3GPP [dB]	MPR [dB]
			26865 (831.5 MHz)		
			Conducted Power [dBm]		
QPSK	1	0	24.44	0	0
	1	36	24.26		0
	1	74	24.29		0
	36	0	23.42	0-1	1
	36	18	23.40		1
	36	37	23.43		1
16QAM	75	0	23.38	0-1	1
	1	0	23.62		1
	1	36	23.44		1
	1	74	23.48	0-2	1
	36	0	22.37		2
	36	18	22.39		2
64QAM	36	37	22.38	0-2	2
	75	0	22.34		2
	1	0	22.56		0-3
	1	36	22.47	2	
	1	74	22.50	2	
	36	0	21.38	0-3	3
36	18	21.39	3		
36	37	21.38	3		
	75	0	21.36		3

Note: LTE Band 26 (Cell) at 15 MHz bandwidth does not support three non-overlapping channels. Per KDB Publication 941225 D05v02, when a device supports overlapping channel assignment in a channel bandwidth configuration, the middle channel of the group of overlapping channels should be selected for testing.

Table 8-24
LTE Band 26 (Cell) Maximum Conducted Powers - 10 MHz Bandwidth

LTE Band 26 (Cell) 10 MHz Bandwidth							
Modulation	RB Size	RB Offset	Low Channel	Mid Channel	High Channel	MPR Allowed per 3GPP [dB]	MPR [dB]
			26740 (819.0 MHz)	26865 (831.5 MHz)	26990 (844.0 MHz)		
			Conducted Power [dBm]				
QPSK	1	0	24.38	24.40	24.35	0	0
	1	25	24.32	24.26	24.46		0
	1	49	24.20	24.26	24.28		0
	25	0	23.35	23.30	23.48	0-1	1
	25	12	23.39	23.34	23.48		1
	25	25	23.35	23.29	23.48		1
16QAM	50	0	23.37	23.30	23.47	0-1	1
	1	0	23.60	23.47	23.65		1
	1	25	23.58	23.47	23.66		1
	1	49	23.50	23.42	23.56	0-2	1
	25	0	22.33	22.29	22.50		2
	25	12	22.39	22.30	22.49		2
64QAM	25	25	22.33	22.25	22.46	0-2	2
	50	0	22.38	22.30	22.46		2
	1	0	22.15	22.47	22.55		0-3
	1	25	21.99	22.39	22.36	2	
	1	49	22.38	22.46	21.88	2	
	25	0	21.15	21.33	21.50	0-3	3
25	12	21.08	21.28	21.29	3		
25	25	21.01	21.30	21.20	3		
	50	0	21.06	21.31	21.28		3



FCC ID: A3LSMT867U		SAR EVALUATION REPORT		Approved by: Quality Manager
Document S/N: 1M1907300131-01-R1.A3L	Test Dates: 08/05/19 - 08/27/19	DUT Type: Portable Tablet		Page 32 of 126

Table 8-25
LTE Band 26 (Cell) Maximum Conducted Powers - 5 MHz Bandwidth

LTE Band 26 (Cell) 5 MHz Bandwidth								
Modulation	RB Size	RB Offset	Low Channel	Mid Channel	High Channel	MPR Allowed per 3GPP [dB]	MPR [dB]	
			26715 (816.5 MHz)	26865 (831.5 MHz)	27015 (846.5 MHz)			
			Conducted Power [dBm]					
QPSK	1	0	24.23	24.15	24.37	0	0	
	1	12	24.28	24.22	24.42		0	
	1	24	24.29	24.23	24.20		0	
	12	0	23.34	23.16	23.43	0-1	1	
	12	6	23.41	23.38	23.54		1	
	12	13	23.39	23.30	23.46		1	
16QAM	25	0	23.36	23.30	23.38	0-1	1	
	1	0	23.46	23.41	23.63		1	
	1	12	23.54	23.47	23.65		1	
	1	24	23.47	23.39	23.51	0-2	1	
	12	0	22.37	22.28	22.45		2	
	12	6	22.43	22.34	22.51		2	
64QAM	12	13	22.39	22.24	22.46	0-2	2	
	25	0	22.35	22.30	22.42		2	
	1	0	22.19	22.44	22.40		0-2	2
	1	12	22.29	22.44	22.19	2		
	1	24	22.13	22.41	21.76	2		
	64QAM	12	0	21.23	21.27	21.28	0-3	3
		12	6	21.43	21.34	21.34		3
		12	13	21.18	21.29	21.05		3
25		0	21.10	21.29	21.03	3		

Table 8-26
LTE Band 26 (Cell) Maximum Conducted Powers - 3 MHz Bandwidth

LTE Band 26 (Cell) 3 MHz Bandwidth								
Modulation	RB Size	RB Offset	Low Channel	Mid Channel	High Channel	MPR Allowed per 3GPP [dB]	MPR [dB]	
			26705 (815.5 MHz)	26865 (831.5 MHz)	27025 (847.5 MHz)			
			Conducted Power [dBm]					
QPSK	1	0	24.20	24.17	24.38	0	0	
	1	7	24.27	24.17	24.36		0	
	1	14	24.25	24.20	24.16		0	
	8	0	23.36	23.23	23.47	0-1	1	
	8	4	23.45	23.33	23.47		1	
	8	7	23.40	23.27	23.41		1	
16QAM	15	0	23.40	23.32	23.45	0-1	1	
	1	0	23.44	23.38	23.62		1	
	1	7	23.48	23.37	23.61		1	
	1	14	23.50	23.39	23.52	0-2	1	
	8	0	22.38	22.28	22.53		2	
	8	4	22.46	22.32	22.50		2	
64QAM	8	7	22.41	22.26	22.48	0-2	2	
	15	0	22.36	22.24	22.43		2	
	1	0	22.32	22.35	22.11		0-2	2
	1	7	22.41	22.37	22.06	2		
	1	14	22.40	22.33	21.70	2		
	64QAM	8	0	21.34	21.27	21.20	0-3	3
		8	4	21.43	21.33	21.18		3
8		7	21.37	21.26	20.90	3		
15		0	21.37	21.28	20.93	3		



FCC ID: A3LSMT867U		SAR EVALUATION REPORT		Approved by: Quality Manager
Document S/N: 1M1907300131-01-R1.A3L	Test Dates: 08/05/19 - 08/27/19	DUT Type: Portable Tablet	Page 33 of 126	

Table 8-27
LTE Band 26 (Cell) Maximum Conducted Powers -1.4 MHz Bandwidth

LTE Band 26 (Cell) 1.4 MHz Bandwidth							
Modulation	RB Size	RB Offset	Low Channel	Mid Channel	High Channel	MPR Allowed per 3GPP [dB]	MPR [dB]
			26697 (814.7 MHz)	26865 (831.5 MHz)	27033 (848.3 MHz)		
			Conducted Power [dBm]				
QPSK	1	0	24.18	24.06	24.28	0	0
	1	2	24.27	24.20	24.31		0
	1	5	24.25	24.11	24.06		0
	3	0	24.24	24.07	24.26		0
	3	2	24.28	24.19	24.22		0
	3	3	24.22	24.15	24.09		0
16QAM	6	0	23.33	23.24	23.31	0-1	1
	1	0	23.37	23.21	23.52	0-1	1
	1	2	23.50	23.40	23.58		1
	1	5	23.40	23.34	23.32		1
	3	0	23.36	23.14	23.40		1
	3	2	23.37	23.30	23.45		1
3	3	23.33	23.23	23.30	1		
64QAM	6	0	22.38	22.25	22.40	0-2	2
	1	0	22.27	22.25	22.25	0-2	2
	1	2	22.45	22.39	22.15		2
	1	5	22.36	22.32	22.09		2
	3	0	22.28	22.24	22.19		2
	3	2	22.30	22.33	22.07		2
	3	3	22.35	22.28	22.08		2
	6	0	21.28	21.21	21.13		0-3

Table 8-28
LTE Band 26 (Cell) Reduced Conducted Powers - 15 MHz Bandwidth

LTE Band 26 (Cell) 15 MHz Bandwidth							
Modulation	RB Size	RB Offset	Mid Channel	MPR Allowed per 3GPP [dB]	MPR [dB]		
			26865 (831.5 MHz)				
			Conducted Power [dBm]				
QPSK	1	0	17.44	0	0		
	1	36	17.36		0		
	1	74	17.42		0		
	16QAM	36	0	17.45	0-1	0	
		36	18	17.43		0	
		36	37	17.41		0	
		75	0	17.41		0	
75		0	17.41	0			
16QAM	1	0	17.62	0-1	0		
	1	36	17.63		0		
	1	74	17.56		0		
	64QAM	36	0	17.46	0-2	0	
		36	18	17.43		0	
		36	37	17.46		0	
64QAM	75	0	17.42	0-2	0		
	1	0	17.61		0		
	1	36	17.58		0		
	1	74	17.54		0		
	64QAM	36	0		17.49	0-3	0
		36	18		17.48		0
		36	37		17.46		0
75		0	17.42	0			

Note: LTE Band 26 (Cell) at 15 MHz bandwidth does not support three non-overlapping channels. Per KDB Publication 941225 D05v02, when a device supports overlapping channel assignment in a channel bandwidth configuration, the middle channel of the group of overlapping channels should be selected for testing.



FCC ID: A3LSMT867U		SAR EVALUATION REPORT		Approved by: Quality Manager
Document S/N: 1M1907300131-01-R1.A3L	Test Dates: 08/05/19 - 08/27/19	DUT Type: Portable Tablet	Page 34 of 126	

Table 8-29
LTE Band 26 (Cell) Reduced Conducted Powers - 10 MHz Bandwidth

LTE Band 26 (Cell) 10 MHz Bandwidth							
Modulation	RB Size	RB Offset	Low Channel	Mid Channel	High Channel	MPR Allowed per 3GPP [dB]	MPR [dB]
			26740 (819.0 MHz)	26865 (831.5 MHz)	26990 (844.0 MHz)		
			Conducted Power [dBm]				
QPSK	1	0	17.53	17.46	17.51	0	0
	1	25	17.48	17.34	17.54		0
	1	49	17.38	17.41	17.48		0
	25	0	17.51	17.43	17.62	0-1	0
	25	12	17.52	17.45	17.67		0
	25	25	17.49	17.44	17.65		0
16QAM	50	0	17.54	17.50	17.66	0-1	0
	1	0	17.77	17.56	17.73		0
	1	25	17.61	17.57	17.76		0
	1	49	17.61	17.57	17.77	0-2	0
	25	0	17.47	17.45	17.62		0
	25	12	17.54	17.45	17.65		0
64QAM	25	25	17.50	17.39	17.62	0-2	0
	50	0	17.53	17.43	17.64		0
	1	0	17.76	17.64	17.67		0
	1	25	17.63	17.56	17.81	0-3	0
	1	49	17.56	17.60	17.68		0
	25	0	17.54	17.49	17.66		0
64QAM	25	12	17.40	17.48	17.72	0-3	0
	25	25	17.54	17.46	17.70		0
	50	0	17.56	17.45	17.67		0

Table 8-30
LTE Band 26 (Cell) Reduced Conducted Powers - 5 MHz Bandwidth

LTE Band 26 (Cell) 5 MHz Bandwidth							
Modulation	RB Size	RB Offset	Low Channel	Mid Channel	High Channel	MPR Allowed per 3GPP [dB]	MPR [dB]
			26715 (816.5 MHz)	26865 (831.5 MHz)	27015 (846.5 MHz)		
			Conducted Power [dBm]				
QPSK	1	0	17.39	17.27	17.50	0	0
	1	12	17.43	17.44	17.55		0
	1	24	17.39	17.35	17.48		0
	12	0	17.48	17.41	17.58	0-1	0
	12	6	17.54	17.49	17.67		0
	12	13	17.55	17.46	17.56		0
16QAM	25	0	17.54	17.46	17.58	0-1	0
	1	0	17.52	17.55	17.79		0
	1	12	17.72	17.55	17.73		0
	1	24	17.69	17.54	17.67	0-2	0
	12	0	17.49	17.42	17.61		0
	12	6	17.64	17.51	17.70		0
64QAM	12	13	17.51	17.47	17.61	0-2	0
	25	0	17.52	17.46	17.56		0
	1	0	17.60	17.55	17.70		0-3
	1	12	17.65	17.58	17.80	0	
	1	24	17.61	17.50	17.65	0	
	12	0	17.55	17.41	17.62	0-3	0
12	6	17.77	17.52	17.80	0		
12	13	17.62	17.48	17.65	0		
25	0	17.60	17.48	17.65	0		





FCC ID: A3LSMT867U		SAR EVALUATION REPORT		Approved by: Quality Manager
Document S/N: 1M1907300131-01-R1.A3L	Test Dates: 08/05/19 - 08/27/19	DUT Type: Portable Tablet	Page 35 of 126	

Table 8-31
LTE Band 26 (Cell) Reduced Conducted Powers - 3 MHz Bandwidth

LTE Band 26 (Cell) 3 MHz Bandwidth							
Modulation	RB Size	RB Offset	Low Channel	Mid Channel	High Channel	MPR Allowed per 3GPP [dB]	MPR [dB]
			26705 (815.5 MHz)	26865 (831.5 MHz)	27025 (847.5 MHz)		
			Conducted Power [dBm]				
QPSK	1	0	17.37	17.23	17.58	0	0
	1	7	17.46	17.30	17.48		0
	1	14	17.41	17.33	17.47		0
	8	0	17.46	17.35	17.60	0-1	0
	8	4	17.55	17.40	17.65		0
	8	7	17.52	17.40	17.61		0
16QAM	15	0	17.56	17.45	17.65	0-1	0
	1	0	17.52	17.48	17.83		0
	1	7	17.66	17.52	17.70		0
	1	14	17.53	17.59	17.70	0-2	0
	8	0	17.52	17.41	17.65		0
	8	4	17.54	17.51	17.68		0
64QAM	8	7	17.55	17.42	17.63	0-2	0
	15	0	17.50	17.41	17.62		0
	1	0	17.53	17.54	17.76		0-2
	1	7	17.66	17.59	17.75	0	
	1	14	17.54	17.53	17.67	0	
	64QAM	8	0	17.54	17.44	17.67	0-3
8		4	17.62	17.50	17.68	0	
8		7	17.58	17.45	17.66	0	
15		0	17.58	17.45	17.65	0	

Table 8-32
LTE Band 26 (Cell) Reduced Conducted Powers -1.4 MHz Bandwidth

LTE Band 26 (Cell) 1.4 MHz Bandwidth							
Modulation	RB Size	RB Offset	Low Channel	Mid Channel	High Channel	MPR Allowed per 3GPP [dB]	MPR [dB]
			26697 (814.7 MHz)	26865 (831.5 MHz)	27033 (848.3 MHz)		
			Conducted Power [dBm]				
QPSK	1	0	17.37	17.22	17.47	0	0
	1	2	17.49	17.38	17.55		0
	1	5	17.37	17.20	17.39		0
	3	0	17.40	17.23	17.48	0-1	0
	3	2	17.42	17.34	17.47		0
	3	3	17.40	17.28	17.45		0
16QAM	6	0	17.46	17.36	17.54	0-1	0
	1	0	17.47	17.47	17.69		0
	1	2	17.66	17.50	17.79		0-1
	1	5	17.49	17.45	17.63	0	
	3	0	17.51	17.20	17.60	0	
	64QAM	3	2	17.60	17.42	17.59	0-2
3		3	17.46	17.36	17.49	0	
6		0	17.54	17.45	17.65	0	
1		0	17.49	17.45	17.66	0-2	0
1		2	17.65	17.51	17.70		0
1		5	17.58	17.46	17.64		0
64QAM	3	0	17.50	17.41	17.66	0-2	0
	3	2	17.63	17.47	17.68		0
	3	3	17.57	17.53	17.61		0
	6	0	17.47	17.38	17.46	0-3	0

FCC ID: A3LSMT867U		SAR EVALUATION REPORT		Approved by: Quality Manager
Document S/N: 1M1907300131-01-R1.A3L	Test Dates: 08/05/19 - 08/27/19	DUT Type: Portable Tablet	Page 36 of 126	

8.2.4

LTE Band 66 (AWS)

Table 8-33
LTE Band 66 (AWS) Maximum Conducted Powers - 20 MHz Bandwidth

LTE Band 66 (AWS) 20 MHz Bandwidth							
Modulation	RB Size	RB Offset	Low Channel	Mid Channel	High Channel	MPR Allowed per 3GPP [dB]	MPR [dB]
			132072 (1720.0 MHz)	132322 (1745.0 MHz)	132572 (1770.0 MHz)		
			Conducted Power [dBm]				
QPSK	1	0	25.04	24.89	25.09	0	0
	1	50	25.02	25.25	24.94		0
	1	99	24.91	25.21	24.68		0
	50	0	24.24	24.43	24.15	0-1	1
	50	25	24.21	24.41	24.14		1
	50	50	24.23	24.34	24.06		1
16QAM	100	0	24.18	24.38	24.08	0-1	1
	1	0	24.27	24.11	24.33		1
	1	50	24.24	24.48	24.20		1
	1	99	24.14	24.43	24.03	0-2	1
	50	0	23.24	23.45	23.17		2
	50	25	23.23	23.44	23.15		2
64QAM	50	50	23.21	23.37	23.09	0-2	2
	100	0	23.18	23.40	23.12		2
	1	0	22.76	22.51	23.23		0-2
	1	50	22.75	22.91	22.97	2	
	1	99	22.38	23.27	22.36	2	
	64QAM	50	0	21.71	21.53	21.92	0-3
50		25	21.63	21.83	21.93	3	
50		50	21.34	21.97	21.55	3	
100		0	21.54	21.66	21.65	3	

Table 8-34
LTE Band 66 (AWS) Maximum Conducted Powers - 15 MHz Bandwidth

LTE Band 66 (AWS) 15 MHz Bandwidth							
Modulation	RB Size	RB Offset	Low Channel	Mid Channel	High Channel	MPR Allowed per 3GPP [dB]	MPR [dB]
			132047 (1717.5 MHz)	132322 (1745.0 MHz)	132597 (1772.5 MHz)		
			Conducted Power [dBm]				
QPSK	1	0	25.00	24.96	24.98	0	0
	1	36	25.04	25.16	24.89		0
	1	74	25.04	25.07	24.44		0
	36	0	24.18	24.35	24.00	0-1	1
	36	18	24.16	24.31	24.00		1
	36	37	24.14	24.25	23.91		1
16QAM	75	0	24.16	24.31	24.00	0-1	1
	1	0	24.25	24.11	24.19		1
	1	36	24.25	24.43	24.15		1
	1	74	24.36	24.31	23.75	0-2	1
	36	0	23.22	23.28	23.06		2
	36	18	23.20	23.34	23.02		2
64QAM	36	37	23.11	23.28	22.96	0-2	2
	75	0	23.16	23.34	23.03		2
	1	0	22.68	22.95	22.90		0-2
	1	36	22.96	22.90	22.65	2	
	1	74	22.45	23.20	22.20	0-3	
	36	0	21.74	21.55	21.99		3
36	18	21.78	21.95	21.93	3		
64QAM	36	37	21.60	22.03	21.38	0-3	3
	75	0	21.64	21.67	21.48		3



FCC ID: A3LSMT867U		SAR EVALUATION REPORT		Approved by: Quality Manager
Document S/N: 1M1907300131-01-R1.A3L	Test Dates: 08/05/19 - 08/27/19	DUT Type: Portable Tablet	Page 37 of 126	

Table 8-35
LTE Band 66 (AWS) Maximum Conducted Powers - 10 MHz Bandwidth

LTE Band 66 (AWS) 10 MHz Bandwidth							
Modulation	RB Size	RB Offset	Low Channel	Mid Channel	High Channel	MPR Allowed per 3GPP [dB]	MPR [dB]
			132022 (1715.0 MHz)	132322 (1745.0 MHz)	132622 (1775.0 MHz)		
			Conducted Power [dBm]				
QPSK	1	0	24.92	25.02	24.70	0	0
	1	25	24.90	25.10	24.69		0
	1	49	24.92	25.11	24.55		0
	25	0	24.06	24.30	23.82	0-1	1
	25	12	24.02	24.24	23.83		1
	25	25	24.00	24.18	23.77		1
16QAM	50	0	24.02	24.25	23.82	0-1	1
	1	0	24.15	24.23	23.98		1
	1	25	24.15	24.36	23.94		1
	1	49	24.17	24.34	23.70	0-2	1
	25	0	23.05	23.28	22.89		2
	25	12	23.08	23.28	22.87		2
64QAM	25	25	23.01	23.22	22.75	0-2	2
	50	0	23.07	23.24	22.84		2
	1	0	22.48	22.42	23.00		0-2
	1	25	22.90	22.94	22.82	2	
	1	49	22.80	23.17	22.43	0-3	
	25	0	21.58	21.60	22.05		3
25	12	21.74	21.89	21.90	3		
64QAM	25	25	21.76	21.95	21.45	0-3	3
	50	0	21.63	21.70	21.66		3

Table 8-36
LTE Band 66 (AWS) Maximum Conducted Powers - 5 MHz Bandwidth

LTE Band 66 (AWS) 5 MHz Bandwidth							
Modulation	RB Size	RB Offset	Low Channel	Mid Channel	High Channel	MPR Allowed per 3GPP [dB]	MPR [dB]
			131997 (1712.5 MHz)	132322 (1745.0 MHz)	132647 (1777.5 MHz)		
			Conducted Power [dBm]				
QPSK	1	0	24.82	25.09	24.71	0	0
	1	12	24.94	25.20	24.47		0
	1	24	25.00	25.12	24.35		0
	12	0	23.93	24.22	23.76	0-1	1
	12	6	24.08	24.26	23.76		1
	12	13	24.04	24.21	23.47		1
16QAM	25	0	24.06	24.22	23.52	0-1	1
	1	0	24.15	24.38	23.94		1
	1	12	24.22	24.44	23.70		1
	1	24	24.26	24.42	23.37	0-2	1
	12	0	23.04	23.28	22.84		2
	12	6	23.13	23.32	22.85		2
64QAM	12	13	23.09	23.25	22.44	0-2	2
	25	0	23.03	23.22	22.58		2
	1	0	22.46	22.70	22.55		0-2
	1	12	22.69	22.96	22.45	2	
	1	24	22.85	23.11	22.43	2	
	64QAM	12	0	21.53	21.80	21.66	0-3
12		6	21.69	21.98	21.45	3	
12		13	21.76	22.00	22.01	0-3	3
25		0	21.60	21.84	22.00		3



FCC ID: A3LSMT867U	 PCTEST ENGINEERING LABORATORY, INC.	SAR EVALUATION REPORT		Approved by: Quality Manager
Document S/N: 1M1907300131-01-R1.A3L	Test Dates: 08/05/19 - 08/27/19	DUT Type: Portable Tablet	Page 38 of 126	

Table 8-37
LTE Band 66 (AWS) Maximum Conducted Powers - 3 MHz Bandwidth

LTE Band 66 (AWS) 3 MHz Bandwidth							
Modulation	RB Size	RB Offset	Low Channel	Mid Channel	High Channel	MPR Allowed per 3GPP [dB]	MPR [dB]
			131987 (1711.5 MHz)	132322 (1745.0 MHz)	132657 (1778.5 MHz)		
			Conducted Power [dBm]				
QPSK	1	0	24.82	25.09	24.55	0	0
	1	7	24.91	25.17	24.37		0
	1	14	24.95	25.09	24.20		0
	8	0	23.94	24.17	23.51	0-1	1
	8	4	24.04	24.26	23.56		1
	8	7	24.06	24.18	23.42		1
	15	0	24.03	24.24	23.47		1
16QAM	1	0	24.00	24.25	23.60	0-1	1
	1	7	24.18	24.37	23.60		1
	1	14	24.10	24.32	23.40		1
	8	0	23.00	23.29	22.63	0-2	2
	8	4	23.10	23.29	22.61		2
	8	7	23.12	23.28	22.46		2
	15	0	22.98	23.18	22.45		2
64QAM	1	0	22.53	22.80	22.66	0-2	2
	1	7	22.63	22.92	22.61		2
	1	14	22.75	23.12	22.55		2
	8	0	21.53	21.88	21.69	0-3	3
	8	4	21.65	22.00	21.60		3
	8	7	21.67	21.99	21.60		3
	15	0	21.55	21.89	21.61		3

Table 8-38
LTE Band 66 (AWS) Maximum Conducted Powers -1.4 MHz Bandwidth

LTE Band 66 (AWS) 1.4 MHz Bandwidth							
Modulation	RB Size	RB Offset	Low Channel	Mid Channel	High Channel	MPR Allowed per 3GPP [dB]	MPR [dB]
			131979 (1710.7 MHz)	132322 (1745.0 MHz)	132665 (1779.3 MHz)		
			Conducted Power [dBm]				
QPSK	1	0	24.81	25.05	24.79	0	0
	1	2	24.89	25.17	24.81		0
	1	5	24.87	25.07	24.64		0
	3	0	24.86	25.00	24.77		0
	3	2	24.85	25.15	24.76		0
	3	3	24.86	25.11	24.64		0
	6	0	23.94	24.11	23.80	0-1	1
16QAM	1	0	24.05	24.28	24.01	0-1	1
	1	2	24.13	24.46	24.06		1
	1	5	24.09	24.34	23.91		1
	3	0	23.95	24.16	23.89		1
	3	2	24.06	24.30	23.95		1
	3	3	23.97	24.23	23.77		1
	6	0	23.00	23.12	22.69	0-2	2
64QAM	1	0	22.45	22.81	22.62	0-2	2
	1	2	22.61	22.97	22.67		2
	1	5	22.55	22.97	22.64		2
	3	0	22.43	22.87	22.62		2
	3	2	22.55	22.93	22.63		2
	3	3	22.61	22.89	22.42		2
	6	0	21.42	21.79	21.62	0-3	3



FCC ID: A3LSMT867U		SAR EVALUATION REPORT		Approved by: Quality Manager
Document S/N: 1M1907300131-01-R1.A3L	Test Dates: 08/05/19 - 08/27/19	DUT Type: Portable Tablet	Page 39 of 126	

Table 8-39
LTE Band 66 (AWS) Reduced Conducted Powers - 20 MHz Bandwidth

LTE Band 66 (AWS) 20 MHz Bandwidth							
Modulation	RB Size	RB Offset	Low Channel	Mid Channel	High Channel	MPR Allowed per 3GPP [dB]	MPR [dB]
			132072 (1720.0 MHz)	132322 (1745.0 MHz)	132572 (1770.0 MHz)		
			Conducted Power [dBm]				
QPSK	1	0	14.25	14.32	14.17	0	0
	1	50	14.21	14.30	14.13		0
	1	99	14.24	14.27	14.12		0
	50	0	14.40	14.45	14.26	0-1	0
	50	25	14.36	14.40	14.17		0
	50	50	14.14	14.42	14.18		0
100	0	14.24	14.27	14.16	0		
16QAM	1	0	14.32	14.49	14.36	0-1	0
	1	50	14.38	14.44	14.21		0
	1	99	14.39	14.43	14.22		0
	50	0	14.37	14.46	14.20	0-2	0
	50	25	14.32	14.49	14.10		0
	50	50	14.24	14.40	14.14		0
100	0	14.27	14.47	14.19	0		
64QAM	1	0	14.32	14.46	14.29	0-2	0
	1	50	14.35	14.49	14.22		0
	1	99	14.39	14.47	14.16		0
	50	0	14.36	14.49	14.24	0-3	0
	50	25	14.37	14.43	14.21		0
	50	50	14.34	14.45	14.14		0
100	0	14.30	14.44	14.19	0		

Table 8-40
LTE Band 66 (AWS) Reduced Conducted Powers - 15 MHz Bandwidth

LTE Band 66 (AWS) 15 MHz Bandwidth							
Modulation	RB Size	RB Offset	Low Channel	Mid Channel	High Channel	MPR Allowed per 3GPP [dB]	MPR [dB]
			132047 (1717.5 MHz)	132322 (1745.0 MHz)	132597 (1772.5 MHz)		
			Conducted Power [dBm]				
QPSK	1	0	14.25	14.41	14.15	0	0
	1	36	14.01	14.29	14.06		0
	1	74	14.06	14.20	13.91		0
	36	0	14.26	14.38	14.11	0-1	0
	36	18	14.23	14.30	14.04		0
	36	37	14.15	14.16	13.94		0
75	0	14.17	14.23	14.03	0		
16QAM	1	0	14.18	14.50	14.36	0-1	0
	1	36	14.00	14.49	14.40		0
	1	74	13.92	14.45	14.22		0
	36	0	14.27	14.33	14.07	0-2	0
	36	18	14.22	14.28	14.02		0
	36	37	14.12	14.13	13.88		0
75	0	14.23	14.30	14.02	0		
64QAM	1	0	14.50	14.47	14.30	0-2	0
	1	36	14.43	14.37	14.20		0
	1	74	14.35	14.36	14.06		0
	36	0	14.24	14.33	14.07	0-3	0
	36	18	14.20	14.29	14.01		0
	36	37	14.10	14.14	13.91		0
75	0	14.22	14.27	14.01	0		



FCC ID: A3LSMT867U		SAR EVALUATION REPORT		Approved by: Quality Manager
Document S/N: 1M1907300131-01-R1.A3L	Test Dates: 08/05/19 - 08/27/19	DUT Type: Portable Tablet	Page 40 of 126	

Table 8-41
LTE Band 66 (AWS) Reduced Conducted Powers - 10 MHz Bandwidth

LTE Band 66 (AWS) 10 MHz Bandwidth							
Modulation	RB Size	RB Offset	Low Channel	Mid Channel	High Channel	MPR Allowed per 3GPP [dB]	MPR [dB]
			132022 (1715.0 MHz)	132322 (1745.0 MHz)	132622 (1775.0 MHz)		
			Conducted Power [dBm]				
QPSK	1	0	13.92	14.14	13.88	0	0
	1	25	13.75	13.93	13.71		0
	1	49	13.76	13.96	13.67		0
	25	0	14.05	14.16	13.90	0-1	0
	25	12	14.02	14.13	13.86		0
	25	25	13.98	14.10	13.80		0
16QAM	50	0	14.03	14.14	13.85	0-1	0
	1	0	14.30	14.50	14.11		0
	1	25	14.13	14.46	13.95		0
	1	49	14.27	14.46	13.86	0-2	0
	25	0	14.12	14.19	13.91		0
	25	12	14.09	14.18	13.88		0
64QAM	25	25	14.11	14.16	13.83	0-2	0
	50	0	14.05	14.11	13.84		0
	1	0	13.65	14.42	14.10		0-3
	1	25	13.58	14.24	13.85	0	
	1	49	13.62	14.38	13.74	0	
	25	0	14.11	14.18	13.95	0-3	0
25	12	14.08	14.17	13.90	0		
25	25	14.09	14.20	13.87	0		
	50	0	14.09	14.15	13.82		0

Table 8-42
LTE Band 66 (AWS) Reduced Conducted Powers - 5 MHz Bandwidth

LTE Band 66 (AWS) 5 MHz Bandwidth							
Modulation	RB Size	RB Offset	Low Channel	Mid Channel	High Channel	MPR Allowed per 3GPP [dB]	MPR [dB]
			131997 (1712.5 MHz)	132322 (1745.0 MHz)	132647 (1777.5 MHz)		
			Conducted Power [dBm]				
QPSK	1	0	13.90	13.91	13.78	0	0
	1	12	14.04	14.04	13.82		0
	1	24	13.95	13.92	13.68		0-1
	12	0	13.99	14.11	13.85	0	
	12	6	14.08	14.13	13.90	0	
	16QAM	12	13	14.03	14.09	13.79	0-1
25		0	14.03	14.06	13.80	0	
1		0	14.03	14.28	14.11	0-2	
1		12	14.13	14.36	14.17		0
1		24	14.07	14.21	13.97		0
64QAM		12	0	13.98	14.10	14.01	0-2
	12	6	14.04	14.18	14.02	0	
	12	13	13.98	14.09	13.95	0-3	
	25	0	14.03	14.15	13.81		0
	1	0	13.89	14.10	14.03		0-3
	1	12	13.98	14.19	14.10	0	
1	24	13.94	14.05	13.91	0		
	12	0	13.98	14.04	13.85		0
	12	6	14.04	14.10	13.85		0
	12	13	13.99	14.03	13.78		0
	25	0	14.02	14.03	13.85		0





FCC ID: A3LSMT867U	 PCTEST ENGINEERING LABORATORY, INC.	SAR EVALUATION REPORT		Approved by: Quality Manager
Document S/N: 1M1907300131-01-R1.A3L	Test Dates: 08/05/19 - 08/27/19	DUT Type: Portable Tablet	Page 41 of 126	

Table 8-43
LTE Band 66 (AWS) Reduced Conducted Powers - 3 MHz Bandwidth

LTE Band 66 (AWS) 3 MHz Bandwidth							
Modulation	RB Size	RB Offset	Low Channel	Mid Channel	High Channel	MPR Allowed per 3GPP [dB]	MPR [dB]
			131987 (1711.5 MHz)	132322 (1745.0 MHz)	132657 (1778.5 MHz)		
			Conducted Power [dBm]				
QPSK	1	0	13.81	14.04	13.76	0	0
	1	7	13.88	14.14	13.75		0
	1	14	13.85	14.11	13.73		0
	8	0	14.05	14.18	13.88	0-1	0
	8	4	14.10	14.18	13.89		0
	8	7	14.07	14.22	13.86		0
16QAM	15	0	14.03	14.11	13.88	0-1	0
	1	0	14.21	14.44	14.28		0
	1	7	14.30	14.50	14.24		0
	8	0	14.18	14.27	13.98	0-2	0
	8	4	14.23	14.30	14.02		0
	8	7	14.13	14.32	13.96		0
64QAM	15	0	14.13	14.16	13.92	0-2	0
	1	0	13.58	14.31	14.05		0
	1	7	13.61	14.42	14.07		0
	8	0	14.24	14.26	13.97	0-3	0
	8	4	14.27	14.28	14.01		0
	8	7	14.18	14.31	13.94		0
	15	0	14.20	14.11	13.85		0

Table 8-44
LTE Band 66 (AWS) Reduced Conducted Powers – 1.4 MHz Bandwidth

LTE Band 66 (AWS) 1.4 MHz Bandwidth							
Modulation	RB Size	RB Offset	Low Channel	Mid Channel	High Channel	MPR Allowed per 3GPP [dB]	MPR [dB]
			131979 (1710.7 MHz)	132322 (1745.0 MHz)	132665 (1779.3 MHz)		
			Conducted Power [dBm]				
QPSK	1	0	13.81	14.16	13.71	0	0
	1	2	13.92	14.24	13.74		0
	1	5	13.81	14.19	13.71		0
	3	0	13.91	14.05	13.67	0-1	0
	3	2	13.96	14.13	13.74		0
	3	3	13.91	14.08	13.65		0
16QAM	6	0	14.04	14.11	13.77	0-1	0
	1	0	14.18	14.35	13.88		0
	1	2	14.28	14.42	13.91		0
	3	0	13.99	14.22	13.83	0-2	0
	3	2	14.00	14.38	13.93		0
	3	3	13.97	14.31	13.84		0
64QAM	6	0	14.02	14.24	13.72	0-2	0
	1	0	13.55	14.08	13.81		0
	1	2	13.66	14.16	13.89		0
	3	0	13.93	14.12	13.62	0-3	0
	3	2	13.94	14.28	13.72		0
	3	3	13.91	14.22	13.57		0
	6	0	14.01	14.11	13.76		0

FCC ID: A3LSMT867U	 PCTEST Engineering Laboratory, Inc.	SAR EVALUATION REPORT		Approved by: Quality Manager
Document S/N: 1M1907300131-01-R1.A3L	Test Dates: 08/05/19 - 08/27/19	DUT Type: Portable Tablet		Page 42 of 126

8.2.5 LTE Band 2 (PCS)

Table 8-45
LTE Band 2 (PCS) Maximum Conducted Powers - 20 MHz Bandwidth

LTE Band 2 (PCS) 20 MHz Bandwidth							
Modulation	RB Size	RB Offset	Low Channel	Mid Channel	High Channel	MPR Allowed per 3GPP [dB]	MPR [dB]
			18700 (1860.0 MHz)	18900 (1880.0 MHz)	19100 (1900.0 MHz)		
			Conducted Power [dBm]				
QPSK	1	0	24.26	24.25	24.33	0	0
	1	50	24.21	24.29	24.32		0
	1	99	24.32	24.38	24.37		0
	50	0	23.36	23.43	23.49	0-1	1
	50	25	23.37	23.46	23.48		1
	50	50	23.36	23.44	23.51		1
16QAM	100	0	23.35	23.45	23.49	0-1	1
	1	0	23.61	23.52	23.62		1
	1	50	23.49	23.51	23.57		1
	1	99	23.55	23.64	23.61	0-2	1
	50	0	22.38	22.43	22.50		2
	50	25	22.36	22.46	22.52		2
64QAM	50	50	22.40	22.48	22.53	0-2	2
	100	0	22.39	22.47	22.52		2
	1	0	22.61	22.51	21.99		0-2
	1	50	22.45	22.57	22.34	2	
	1	99	22.56	22.09	22.28	2	
	64QAM	50	0	21.38	21.45	20.82	0-3
50		25	21.40	21.48	21.29	3	
50		50	21.42	21.20	21.52	3	
100		0	21.39	21.48	21.16	3	

Table 8-46
LTE Band 2 (PCS) Maximum Conducted Powers - 15 MHz Bandwidth

LTE Band 2 (PCS) 15 MHz Bandwidth							
Modulation	RB Size	RB Offset	Low Channel	Mid Channel	High Channel	MPR Allowed per 3GPP [dB]	MPR [dB]
			18675 (1857.5 MHz)	18900 (1880.0 MHz)	19125 (1902.5 MHz)		
			Conducted Power [dBm]				
QPSK	1	0	24.30	24.24	24.33	0	0
	1	36	24.18	24.17	24.24		0
	1	74	24.23	24.23	24.30		0
	36	0	23.27	23.32	23.46	0-1	1
	36	18	23.31	23.35	23.48		1
	36	37	23.32	23.40	23.48		1
16QAM	75	0	23.30	23.37	23.46	0-1	1
	1	0	23.54	23.50	23.61		1
	1	36	23.42	23.50	23.56		1
	1	74	23.47	23.44	23.63	0-2	1
	36	0	22.30	22.34	22.50		2
	36	18	22.31	22.40	22.52		2
64QAM	36	37	22.32	22.41	22.50	0-2	2
	75	0	22.32	22.39	22.50		2
	1	0	22.42	22.45	22.03		0-2
	1	36	22.42	22.44	22.53	2	
	1	74	22.43	21.90	22.03	2	
	64QAM	36	0	21.35	21.40	21.34	0-3
36		18	21.36	21.41	21.56	3	
36		37	21.38	21.30	21.53	3	
75		0	21.33	21.39	21.33	3	



FCC ID: A3LSMT867U		SAR EVALUATION REPORT		Approved by: Quality Manager
Document S/N: 1M1907300131-01-R1.A3L	Test Dates: 08/05/19 - 08/27/19	DUT Type: Portable Tablet	Page 43 of 126	

Table 8-47
LTE Band 2 (PCS) Maximum Conducted Powers - 10 MHz Bandwidth

LTE Band 2 (PCS) 10 MHz Bandwidth								
Modulation	RB Size	RB Offset	Low Channel	Mid Channel	High Channel	MPR Allowed per 3GPP [dB]	MPR [dB]	
			18650 (1855.0 MHz)	18900 (1880.0 MHz)	19150 (1905.0 MHz)			
			Conducted Power [dBm]					
QPSK	1	0	24.12	24.08	24.38	0	0	
	1	25	24.16	24.22	24.30		0	
	1	49	24.06	24.14	24.28		0	
	25	0	23.27	23.29	23.46	0-1	1	
	25	12	23.25	23.31	23.48		1	
	25	25	23.21	23.29	23.40		1	
16QAM	50	0	23.25	23.29	23.45	0-1	1	
	1	0	23.36	23.40	23.67		0-1	1
	1	25	23.40	23.43	23.57			1
	1	49	23.39	23.39	23.50	0-2		1
	25	0	22.27	22.30	22.50		2	
	25	12	22.28	22.31	22.52		2	
64QAM	25	25	22.22	22.33	22.45	0-2	2	
	50	0	22.26	22.29	22.45		2	
	1	0	22.35	22.43	22.65		0-2	2
	1	25	22.47	22.43	22.57	2		
	1	49	22.43	22.20	22.05	0-3		2
	25	0	21.30	21.33	21.49		3	
25	12	21.32	21.37	21.53	3			
64QAM	25	25	21.25	21.30	21.31	0-3	3	
	50	0	21.30	21.33	21.41		3	

Table 8-48
LTE Band 2 (PCS) Maximum Conducted Powers - 5 MHz Bandwidth

LTE Band 2 (PCS) 5 MHz Bandwidth								
Modulation	RB Size	RB Offset	Low Channel	Mid Channel	High Channel	MPR Allowed per 3GPP [dB]	MPR [dB]	
			18625 (1852.5 MHz)	18900 (1880.0 MHz)	19175 (1907.5 MHz)			
			Conducted Power [dBm]					
QPSK	1	0	24.18	24.15	24.24	0	0	
	1	12	24.23	24.24	24.33		0	
	1	24	24.19	24.20	24.30		0	
	12	0	23.28	23.23	23.40	0-1	1	
	12	6	23.32	23.27	23.40		1	
	12	13	23.30	23.35	23.52		1	
16QAM	25	0	23.32	23.30	23.41	0-1	1	
	1	0	23.46	23.41	23.50		0-1	1
	1	12	23.50	23.42	23.60			1
	1	24	23.41	23.45	23.55	0-2		1
	12	0	22.35	22.28	22.41		2	
	12	6	22.40	22.31	22.52		2	
64QAM	12	13	22.35	22.38	22.53	0-2	2	
	25	0	22.35	22.31	22.44		0-2	2
	1	0	22.37	22.30	22.48			0-2
	1	12	22.50	22.47	22.22	0-3		
	1	24	22.48	22.43	21.91		0-3	
	12	0	21.38	21.28	21.44			3
64QAM	12	6	21.43	21.38	21.41	0-3		3
	12	13	21.38	21.43	21.08		3	
	25	0	21.35	21.34	21.12		3	





FCC ID: A3LSMT867U		SAR EVALUATION REPORT		Approved by: Quality Manager
Document S/N: 1M1907300131-01-R1.A3L	Test Dates: 08/05/19 - 08/27/19	DUT Type: Portable Tablet	Page 44 of 126	

Table 8-49
LTE Band 2 (PCS) Maximum Conducted Powers - 3 MHz Bandwidth

LTE Band 2 (PCS) 3 MHz Bandwidth							
Modulation	RB Size	RB Offset	Low Channel	Mid Channel	High Channel	MPR Allowed per 3GPP [dB]	MPR [dB]
			18615 (1851.5 MHz)	18900 (1880.0 MHz)	19185 (1908.5 MHz)		
			Conducted Power [dBm]				
QPSK	1	0	24.16	24.13	24.27	0	0
	1	7	24.18	24.20	24.28		0
	1	14	24.24	24.24	24.34		0
	8	0	23.29	23.20	23.45	0-1	1
	8	4	23.33	23.32	23.50		1
	8	7	23.31	23.31	23.47		1
	15	0	23.33	23.29	23.47		1
16QAM	1	0	23.44	23.37	23.50	0-1	1
	1	7	23.46	23.44	23.58		1
	1	14	23.55	23.43	23.61		1
	8	0	22.39	22.30	22.50	0-2	2
	8	4	22.42	22.41	22.53		2
	8	7	22.40	22.27	22.55		2
	15	0	22.35	22.30	22.46		2
64QAM	1	0	22.38	22.37	22.36	0-2	2
	1	7	22.47	22.44	22.08		2
	1	14	22.62	22.50	21.86		2
	8	0	21.39	21.27	21.22	0-3	3
	8	4	21.39	21.41	21.10		3
	8	7	21.42	21.39	20.95		3
	15	0	21.41	21.32	21.10		3

Table 8-50
LTE Band 2 (PCS) Maximum Conducted Powers -1.4 MHz Bandwidth

LTE Band 2 (PCS) 1.4 MHz Bandwidth							
Modulation	RB Size	RB Offset	Low Channel	Mid Channel	High Channel	MPR Allowed per 3GPP [dB]	MPR [dB]
			18607 (1850.7 MHz)	18900 (1880.0 MHz)	19193 (1909.3 MHz)		
			Conducted Power [dBm]				
QPSK	1	0	24.12	24.02	24.15	0	0
	1	2	24.22	24.12	24.30		0
	1	5	24.17	24.13	24.20		0
	3	0	24.17	24.03	24.23	0-1	0
	3	2	24.20	24.20	24.28		0
	3	3	24.19	24.18	24.25		0
	6	0	23.25	23.22	23.34		1
16QAM	1	0	23.35	23.29	23.55	0-1	1
	1	2	23.45	23.45	23.49		1
	1	5	23.49	23.40	23.50		1
	3	0	23.46	23.22	23.34	0-2	1
	3	2	23.32	23.35	23.47		1
	3	3	23.34	23.26	23.30		1
	6	0	22.32	22.28	22.43		2
64QAM	1	0	22.44	22.30	22.04	0-2	2
	1	2	22.50	22.44	22.00		2
	1	5	22.44	22.45	21.80		2
	3	0	22.40	22.29	21.93	0-3	2
	3	2	22.45	22.40	21.92		2
	3	3	22.39	22.36	21.84		2
	6	0	21.31	21.21	20.83		3

FCC ID: A3LSMT867U		SAR EVALUATION REPORT		Approved by: Quality Manager
Document S/N: 1M1907300131-01-R1.A3L	Test Dates: 08/05/19 - 08/27/19	DUT Type: Portable Tablet		Page 45 of 126

**Table 8-51
LTE Band 2 (PCS) Reduced Conducted Powers - 20 MHz Bandwidth**

LTE Band 2 (PCS) 20 MHz Bandwidth							
Modulation	RB Size	RB Offset	Low Channel	Mid Channel	High Channel	MPR Allowed per 3GPP [dB]	MPR [dB]
			18700 (1860.0 MHz)	18900 (1880.0 MHz)	19100 (1900.0 MHz)		
			Conducted Power [dBm]				
QPSK	1	0	13.89	14.00	13.97	0	0
	1	50	13.77	13.94	13.95		0
	1	99	13.76	13.95	13.90		0
	50	0	13.93	14.10	14.13	0-1	0
	50	25	13.91	14.07	14.10		0
	50	50	13.92	14.08	14.01		0
	100	0	13.88	13.95	13.96		0
16QAM	1	0	14.19	14.29	14.29	0-1	0
	1	50	14.17	14.28	14.30		0
	1	99	14.19	14.34	14.26		0
	50	0	13.95	14.08	14.11	0-2	0
	50	25	13.91	14.08	14.10		0
	50	50	13.93	14.02	14.03		0
	100	0	13.94	14.08	14.09		0
64QAM	1	0	14.08	14.09	14.12	0-2	0
	1	50	14.04	14.16	14.23		0
	1	99	14.07	14.12	14.19		0
	50	0	14.03	14.08	14.08	0-3	0
	50	25	14.01	14.02	14.07		0
	50	50	13.97	14.06	14.07		0
	100	0	13.96	14.05	14.07		0

**Table 8-52
LTE Band 2 (PCS) Reduced Conducted Powers - 15 MHz Bandwidth**

LTE Band 2 (PCS) 15 MHz Bandwidth							
Modulation	RB Size	RB Offset	Low Channel	Mid Channel	High Channel	MPR Allowed per 3GPP [dB]	MPR [dB]
			18675 (1857.5 MHz)	18900 (1880.0 MHz)	19125 (1902.5 MHz)		
			Conducted Power [dBm]				
QPSK	1	0	13.92	13.93	14.06	0	0
	1	36	13.82	13.95	14.02		0
	1	74	13.73	13.96	13.94		0
	36	0	13.94	14.10	14.15	0-1	0
	36	18	13.97	14.12	14.17		0
	36	37	13.95	14.16	14.15		0
	75	0	14.00	14.13	14.16		0
16QAM	1	0	14.30	13.90	14.36	0-1	0
	1	36	14.10	14.25	14.26		0
	1	74	14.11	14.28	14.26		0
	36	0	14.00	14.10	14.15	0-2	0
	36	18	13.96	14.10	14.15		0
	36	37	13.98	14.11	14.15		0
	75	0	13.98	14.11	14.14		0
64QAM	1	0	14.13	14.19	14.14	0-2	0
	1	36	14.09	14.14	14.12		0
	1	74	14.10	14.15	14.04		0
	36	0	14.05	14.02	14.14	0-3	0
	36	18	14.00	14.04	14.16		0
	36	37	14.00	14.06	14.14		0
	75	0	14.00	14.04	14.08		0



FCC ID: A3LSMT867U	 PCTEST ENGINEERING LABORATORY, INC.	SAR EVALUATION REPORT		Approved by: Quality Manager
Document S/N: 1M1907300131-01-R1.A3L	Test Dates: 08/05/19 - 08/27/19	DUT Type: Portable Tablet	Page 46 of 126	

Table 8-53
LTE Band 2 (PCS) Reduced Conducted Powers - 10 MHz Bandwidth

LTE Band 2 (PCS) 10 MHz Bandwidth							
Modulation	RB Size	RB Offset	Low Channel	Mid Channel	High Channel	MPR Allowed per 3GPP [dB]	MPR [dB]
			18650 (1855.0 MHz)	18900 (1880.0 MHz)	19150 (1905.0 MHz)		
			Conducted Power [dBm]				
QPSK	1	0	13.80	13.90	14.00	0	0
	1	25	13.82	13.91	13.91		0
	1	49	13.75	13.82	13.80		0
	25	0	13.88	13.97	14.03	0-1	0
	25	12	13.91	13.98	14.03		0
	25	25	13.85	13.95	13.98		0
16QAM	50	0	13.87	14.00	14.03	0-1	0
	1	0	14.09	14.16	14.23		0
	1	25	14.07	14.25	14.30		0
	1	49	14.01	14.15	14.17	0-2	0
	25	0	13.91	14.00	14.02		0
	25	12	13.85	13.98	14.04		0
64QAM	25	25	13.82	13.97	13.96	0-2	0
	50	0	13.83	13.92	14.00		0
	1	0	14.08	14.06	14.24		0
	1	25	14.09	14.07	14.15	0-2	0
	1	49	14.02	14.02	14.00		0
	25	0	14.10	14.02	14.07		0
64QAM	25	12	14.00	14.00	14.09	0-3	0
	25	25	13.91	13.94	14.02		0
	50	0	13.97	14.00	14.03		0

Table 8-54
LTE Band 2 (PCS) Reduced Conducted Powers - 5 MHz Bandwidth

LTE Band 2 (PCS) 5 MHz Bandwidth							
Modulation	RB Size	RB Offset	Low Channel	Mid Channel	High Channel	MPR Allowed per 3GPP [dB]	MPR [dB]
			18625 (1852.5 MHz)	18900 (1880.0 MHz)	19175 (1907.5 MHz)		
			Conducted Power [dBm]				
QPSK	1	0	13.87	13.86	13.87	0	0
	1	12	13.86	13.96	14.00		0
	1	24	13.79	13.87	13.85		0
	12	0	13.88	13.95	13.95	0-1	0
	12	6	13.96	14.02	14.02		0
	12	13	13.95	14.03	14.02		0
16QAM	25	0	13.94	14.00	13.99	0-1	0
	1	0	14.13	14.23	14.20		0
	1	12	14.15	14.20	14.34		0
	1	24	14.03	14.30	14.25	0-2	0
	12	0	13.91	13.96	14.00		0
	12	6	14.00	14.00	14.08		0
64QAM	12	13	13.94	14.08	14.09	0-2	0
	25	0	13.95	13.97	13.98		0
	1	0	14.05	14.02	14.11		0
	1	12	14.11	14.09	14.20	0-3	0
	1	24	14.11	14.06	14.14		0
	12	0	14.00	13.97	14.03		0
64QAM	12	6	14.08	13.98	14.04	0-3	0
	12	13	14.04	14.07	14.08		0
	25	0	14.01	14.01	14.01		0





FCC ID: A3LSMT867U	 PCTEST ENGINEERING LABORATORY, INC.	SAR EVALUATION REPORT		Approved by: Quality Manager
Document S/N: 1M1907300131-01-R1.A3L	Test Dates: 08/05/19 - 08/27/19	DUT Type: Portable Tablet	Page 47 of 126	

Table 8-55
LTE Band 2 (PCS) Reduced Conducted Powers - 3 MHz Bandwidth

LTE Band 2 (PCS) 3 MHz Bandwidth								
Modulation	RB Size	RB Offset	Low Channel	Mid Channel	High Channel	MPR Allowed per 3GPP [dB]	MPR [dB]	
			18615 (1851.5 MHz)	18900 (1880.0 MHz)	19185 (1908.5 MHz)			
			Conducted Power [dBm]					
QPSK	1	0	14.00	14.06	14.18	0	0	
	1	7	14.06	14.11	14.15		0	
	1	14	14.01	14.15	14.21		0	
	8	0	14.14	14.15	14.29	0-1	0	
	8	4	14.22	14.28	14.36		0	
	8	7	14.22	14.28	14.33		0	
16QAM	15	0	14.18	14.21	14.28	0-1	0	
	1	0	14.33	14.35	14.41		0	
	1	7	14.35	14.50	14.48		0	
	1	14	14.40	14.44	14.45	0-2	0	
	8	0	14.15	14.19	14.32		0	
	8	4	14.20	14.35	14.39		0	
64QAM	8	7	14.23	14.33	14.41	0-2	0	
	15	0	14.17	14.17	14.28		0	
	1	0	14.30	14.19	14.35		0	
	1	7	14.36	14.26	14.35	0-2	0	
	1	14	14.40	14.32	14.44		0	
	8	0	14.25	14.19	14.33		0	
	64QAM	8	4	14.33	14.30	14.37	0-3	0
		8	7	14.32	14.34	14.35		0
15		0	14.26	14.24	14.32	0		

Table 8-56
LTE Band 2 (PCS) Reduced Conducted Powers – 1.4 MHz Bandwidth

LTE Band 2 (PCS) 1.4 MHz Bandwidth							
Modulation	RB Size	RB Offset	Low Channel	Mid Channel	High Channel	MPR Allowed per 3GPP [dB]	MPR [dB]
			18607 (1850.7 MHz)	18900 (1880.0 MHz)	19193 (1909.3 MHz)		
			Conducted Power [dBm]				
QPSK	1	0	14.00	14.01	14.07	0	0
	1	2	14.12	14.20	14.22		0
	1	5	14.09	14.11	14.16		0
	3	0	14.07	14.00	14.08	0-1	0
	3	2	14.13	14.20	14.17		0
	3	3	14.09	14.18	14.17		0
16QAM	6	0	14.12	14.22	14.24	0-1	0
	1	0	14.29	14.25	14.39		0
	1	2	14.38	14.44	14.50		0
	1	5	14.36	14.49	14.44	0-1	0
	3	0	14.20	14.22	14.25		0
	3	2	14.24	14.44	14.39		0
64QAM	3	3	14.25	14.35	14.35	0-2	0
	6	0	14.17	14.28	14.30		0
	1	0	14.29	14.18	14.31		0
	1	2	14.40	14.35	14.40	0-2	0
	1	5	14.30	14.31	14.17		0
	3	0	14.31	14.12	14.27		0
	3	2	14.32	14.22	14.30	0-3	0
	3	3	14.27	14.23	14.31		0
6	0	14.21	14.15	14.23	0		

FCC ID: A3LSMT867U		SAR EVALUATION REPORT		Approved by: Quality Manager
Document S/N: 1M1907300131-01-R1.A3L	Test Dates: 08/05/19 - 08/27/19	DUT Type: Portable Tablet	Page 48 of 126	

8.2.1

LTE Band 25 (PCS)

Table 8-57
LTE Band 25 (PCS) Maximum Conducted Powers - 20 MHz Bandwidth

LTE Band 25 (PCS) 20 MHz Bandwidth							
Modulation	RB Size	RB Offset	Low Channel	Mid Channel	High Channel	MPR Allowed per 3GPP [dB]	MPR [dB]
			26140 (1860.0 MHz)	26365 (1882.5 MHz)	26590 (1905.0 MHz)		
			Conducted Power [dBm]				
QPSK	1	0	23.88	23.96	24.16	0	0
	1	50	23.73	24.01	24.01		0
	1	99	23.82	24.04	23.88		0
	50	0	22.89	23.13	23.09	0-1	1
	50	25	22.94	23.13	23.14		1
	50	50	22.92	23.12	23.05		1
16QAM	100	0	22.90	23.12	23.11	0-1	1
	1	0	23.13	23.22	23.33		1
	1	50	22.99	23.23	23.27		1
	1	99	23.03	23.29	23.11	0-2	1
	50	0	21.91	22.11	22.12		2
	50	25	21.94	22.15	22.15		2
64QAM	50	50	21.92	22.13	22.10	0-2	2
	100	0	21.91	22.13	22.12		2
	1	0	22.13	22.18	21.56		0-3
	1	50	21.99	22.02	22.17	2	
	1	99	22.04	21.54	21.34	2	
	50	0	20.91	21.12	20.85	0-3	3
50	25	20.96	21.11	21.10	3		
50	50	20.93	20.50	20.60	3		
100	0	20.92	21.08	20.66		3	

Table 8-58
LTE Band 25 (PCS) Maximum Conducted Powers - 15 MHz Bandwidth

LTE Band 25 (PCS) 15 MHz Bandwidth								
Modulation	RB Size	RB Offset	Low Channel	Mid Channel	High Channel	MPR Allowed per 3GPP [dB]	MPR [dB]	
			26115 (1857.5 MHz)	26365 (1882.5 MHz)	26615 (1907.5 MHz)			
			Conducted Power [dBm]					
QPSK	1	0	23.83	23.85	24.11	0	0	
	1	36	23.77	23.93	24.02		0	
	1	74	23.77	23.99	24.00		0	
	36	0	22.96	23.07	23.14	0-1	1	
	36	18	22.95	23.11	23.20		1	
	36	37	22.93	23.12	23.16		1	
16QAM	75	0	22.91	23.08	23.18	0-1	1	
	1	0	23.15	23.20	23.42		0-1	1
	1	36	23.07	23.18	23.32			1
	1	74	23.08	23.20	23.30	0-2		1
	36	0	21.94	22.07	22.16		2	
	36	18	21.95	22.17	22.19		2	
64QAM	36	37	21.95	22.15	22.21	0-2	2	
	75	0	21.96	22.12	22.19		2	
	1	0	22.11	22.15	22.10		0-2	2
	1	36	22.00	22.15	21.80	0-3		2
	1	74	22.00	21.44	21.43			2
	36	0	21.00	21.12	21.12		0-3	3
36	18	21.00	21.20	21.05	3			
36	37	20.98	20.55	20.50	3			
75	0	20.94	20.99	20.72		3		



FCC ID: A3LSMT867U		SAR EVALUATION REPORT		Approved by: Quality Manager
Document S/N: 1M1907300131-01-R1.A3L	Test Dates: 08/05/19 - 08/27/19	DUT Type: Portable Tablet	Page 49 of 126	

Table 8-59
LTE Band 25 (PCS) Maximum Conducted Powers - 10 MHz Bandwidth

LTE Band 25 (PCS) 10 MHz Bandwidth							
Modulation	RB Size	RB Offset	Low Channel	Mid Channel	High Channel	MPR Allowed per 3GPP [dB]	MPR [dB]
			26090 (1855.0 MHz)	26365 (1882.5 MHz)	26640 (1910.0 MHz)		
			Conducted Power [dBm]				
QPSK	1	0	23.73	23.87	23.95	0	0
	1	25	23.68	23.89	23.94		0
	1	49	23.64	23.85	23.91		0
	25	0	22.81	22.98	23.01	0-1	1
	25	12	22.83	23.02	23.05		1
	25	25	22.82	23.00	23.03		1
16QAM	50	0	22.83	23.00	23.05	0-1	1
	1	0	23.00	23.24	23.00		1
	1	25	22.92	23.17	23.19		1
	1	49	22.84	23.07	23.25	0-2	1
	25	0	21.87	22.00	22.06		2
	25	12	21.83	22.03	22.06		2
64QAM	25	25	21.81	22.04	22.12	0-2	2
	50	0	21.84	22.03	22.06		2
	1	0	22.03	22.19	22.06		2
	1	25	21.87	22.07	21.48	0-3	2
	1	49	21.91	21.57	21.28		2
	25	0	20.86	21.03	20.78		3
64QAM	25	12	20.87	21.03	20.53	0-3	3
	25	25	20.85	20.65	20.40		3
	50	0	20.85	20.91	20.43		3

Table 8-60
LTE Band 25 (PCS) Maximum Conducted Powers - 5 MHz Bandwidth

LTE Band 25 (PCS) 5 MHz Bandwidth							
Modulation	RB Size	RB Offset	Low Channel	Mid Channel	High Channel	MPR Allowed per 3GPP [dB]	MPR [dB]
			26065 (1852.5 MHz)	26365 (1882.5 MHz)	26665 (1912.5 MHz)		
			Conducted Power [dBm]				
QPSK	1	0	23.70	23.81	23.86	0	0
	1	12	23.79	24.00	23.94		0
	1	24	23.79	24.06	23.98		0
	12	0	22.89	22.96	22.97	0-1	1
	12	6	22.93	23.02	23.10		1
	12	13	22.90	23.11	23.12		1
16QAM	25	0	22.90	22.96	23.05	0-1	1
	1	0	23.00	23.14	23.12		1
	1	12	23.00	23.29	23.17		1
	1	24	23.00	23.28	23.18	0-2	1
	12	0	21.90	21.98	22.05		2
	12	6	21.97	22.08	22.15		2
64QAM	12	13	21.93	22.14	22.13	0-2	2
	25	0	21.91	22.01	22.08		2
	1	0	21.97	22.14	21.45		0-3
	1	12	22.08	22.12	21.18	2	
	1	24	22.05	21.81	21.20	2	
	64QAM	12	0	20.95	21.02	20.28	0-3
12		6	21.00	21.06	20.22	3	
12		13	20.90	20.95	20.20	3	
25		0	20.93	20.99	20.20	3	



FCC ID: A3LSMT867U	 PCTEST ENGINEERING LABORATORY, INC.	SAR EVALUATION REPORT		Approved by: Quality Manager
Document S/N: 1M1907300131-01-R1.A3L	Test Dates: 08/05/19 - 08/27/19	DUT Type: Portable Tablet	Page 50 of 126	

Table 8-61
LTE Band 25 (PCS) Maximum Conducted Powers - 3 MHz Bandwidth

LTE Band 25 (PCS) 3 MHz Bandwidth							
Modulation	RB Size	RB Offset	Low Channel	Mid Channel	High Channel	MPR Allowed per 3GPP [dB]	MPR [dB]
			26055 (1851.5 MHz)	26365 (1882.5 MHz)	26675 (1913.5 MHz)		
			Conducted Power [dBm]				
QPSK	1	0	23.84	23.84	23.83	0	0
	1	7	23.98	23.96	24.00		0
	1	14	23.97	23.96	24.03		0
	8	0	23.01	22.93	23.01	0-1	1
	8	4	23.16	23.07	23.12		1
	8	7	23.13	23.04	23.06		1
	15	0	23.11	23.00	23.09		1
16QAM	1	0	23.10	23.05	23.15	0-1	1
	1	7	23.22	23.15	23.21		1
	1	14	23.21	23.18	23.23		1
	8	0	22.07	22.04	22.05	0-2	2
	8	4	22.21	22.12	22.08		2
	8	7	22.18	22.08	22.15		2
	15	0	22.11	21.96	22.07		2
64QAM	1	0	22.27	22.11	21.26	0-2	2
	1	7	22.20	22.14	21.23		2
	1	14	22.13	22.02	21.27		2
	8	0	21.10	21.02	20.26	0-3	3
	8	4	21.06	21.15	20.26		3
	8	7	21.13	21.02	20.29		3
	15	0	21.07	21.00	20.25		3

Table 8-62
LTE Band 25 (PCS) Maximum Conducted Powers -1.4 MHz Bandwidth

LTE Band 25 (PCS) 1.4 MHz Bandwidth							
Modulation	RB Size	RB Offset	Low Channel	Mid Channel	High Channel	MPR Allowed per 3GPP [dB]	MPR [dB]
			26047 (1850.7 MHz)	26365 (1882.5 MHz)	26683 (1914.3 MHz)		
			Conducted Power [dBm]				
QPSK	1	0	23.70	23.77	23.89	0	0
	1	2	23.82	23.96	24.05		0
	1	5	23.77	23.88	23.95		0
	3	0	23.73	23.82	23.92		0
	3	2	23.78	23.96	23.99		0
	3	3	23.80	23.96	23.97		0
	6	0	22.84	22.94	23.04	0-1	1
16QAM	1	0	22.95	23.10	23.23	0-1	1
	1	2	22.99	23.24	23.22		1
	1	5	22.98	23.17	23.18		1
	3	0	22.88	23.00	23.12		1
	3	2	22.95	23.10	23.15		1
	3	3	22.95	23.07	23.11		1
	6	0	21.93	22.02	22.12	0-2	2
64QAM	1	0	22.00	22.02	21.25	0-2	2
	1	2	22.08	22.20	21.26		2
	1	5	22.00	22.04	21.25		2
	3	0	21.97	22.04	21.33		2
	3	2	22.00	22.15	21.38		2
	3	3	22.00	22.15	21.37		2
	6	0	20.87	20.95	20.25	0-3	3



FCC ID: A3LSMT867U		SAR EVALUATION REPORT		Approved by: Quality Manager
Document S/N: 1M1907300131-01-R1.A3L	Test Dates: 08/05/19 - 08/27/19	DUT Type: Portable Tablet	Page 51 of 126	

Table 8-63
LTE Band 25 (PCS) Reduced Conducted Powers - 20 MHz Bandwidth

LTE Band 25 (PCS) 20 MHz Bandwidth							
Modulation	RB Size	RB Offset	Low Channel	Mid Channel	High Channel	MPR Allowed per 3GPP [dB]	MPR [dB]
			26140 (1860.0 MHz)	26365 (1882.5 MHz)	26590 (1905.0 MHz)		
			Conducted Power [dBm]				
QPSK	1	0	14.02	13.92	14.15	0	0
	1	50	13.87	13.97	14.00		0
	1	99	13.91	13.99	14.00		0
	50	0	14.07	14.12	14.20	0-1	0
	50	25	14.00	14.09	14.12		0
	50	50	13.95	14.06	14.08		0
	100	0	13.98	13.90	14.11		0
16QAM	1	0	14.22	14.19	14.29	0-1	0
	1	50	14.23	14.22	14.27		0
	1	99	14.26	14.10	14.29		0
	50	0	14.08	14.15	14.15	0-2	0
	50	25	14.02	14.12	14.11		0
	50	50	13.96	14.05	14.14		0
	100	0	14.01	14.07	14.10		0
64QAM	1	0	14.20	14.28	14.28	0-2	0
	1	50	14.04	14.23	14.16		0
	1	99	14.09	14.22	14.16		0
	50	0	14.02	14.25	14.16	0-3	0
	50	25	14.02	14.27	14.17		0
	50	50	14.00	14.17	14.13		0
	100	0	14.05	14.19	14.10		0

Table 8-64
LTE Band 25 (PCS) Reduced Conducted Powers - 15 MHz Bandwidth

LTE Band 25 (PCS) 15 MHz Bandwidth							
Modulation	RB Size	RB Offset	Low Channel	Mid Channel	High Channel	MPR Allowed per 3GPP [dB]	MPR [dB]
			26115 (1857.5 MHz)	26365 (1882.5 MHz)	26615 (1907.5 MHz)		
			Conducted Power [dBm]				
QPSK	1	0	14.00	14.03	14.16	0	0
	1	36	13.92	14.11	14.18		0
	1	74	13.94	14.16	14.19		0
	36	0	14.15	14.25	14.33	0-1	0
	36	18	14.05	14.19	14.33		0
	36	37	14.05	14.19	14.22		0
	75	0	14.03	14.16	14.21		0
16QAM	1	0	14.35	14.08	14.15	0-1	0
	1	36	14.36	14.14	14.48		0
	1	74	14.25	14.42	14.49		0
	36	0	14.13	14.18	14.30	0-2	0
	36	18	14.12	14.16	14.26		0
	36	37	14.06	14.15	14.25		0
	75	0	14.11	14.18	14.24		0
64QAM	1	0	14.00	14.08	14.06	0-2	0
	1	36	13.85	14.05	13.91		0
	1	74	13.81	13.97	13.89		0
	36	0	13.76	14.01	13.94	0-3	0
	36	18	13.73	14.06	13.93		0
	36	37	13.71	14.04	13.90		0
	75	0	13.77	14.03	13.82		0



FCC ID: A3LSMT867U	 PCTEST ENGINEERING LABORATORY, INC.	SAR EVALUATION REPORT		Approved by: Quality Manager
Document S/N: 1M1907300131-01-R1.A3L	Test Dates: 08/05/19 - 08/27/19	DUT Type: Portable Tablet	Page 52 of 126	

Table 8-65
LTE Band 25 (PCS) Reduced Conducted Powers - 10 MHz Bandwidth

LTE Band 25 (PCS) 10 MHz Bandwidth							
Modulation	RB Size	RB Offset	Low Channel	Mid Channel	High Channel	MPR Allowed per 3GPP [dB]	MPR [dB]
			26090 (1855.0 MHz)	26365 (1882.5 MHz)	26640 (1910.0 MHz)		
			Conducted Power [dBm]				
QPSK	1	0	13.95	13.96	14.13	0	0
	1	25	13.88	13.94	14.05		0
	1	49	13.89	13.92	13.83		0
	25	0	13.96	14.04	14.10	0-1	0
	25	12	13.90	13.97	14.15		0
	25	25	13.91	14.00	14.15		0
16QAM	50	0	13.91	14.00	14.14	0-1	0
	1	0	14.21	14.29	14.41		0
	1	25	14.20	14.22	14.33		0
	1	49	14.14	14.36	14.29	0-2	0
	25	0	13.95	14.04	14.18		0
	25	12	13.94	14.11	14.15		0
64QAM	25	25	13.88	13.94	14.09	0-2	0
	50	0	13.94	14.09	14.10		0
	1	0	13.92	13.99	13.84		0
	1	25	13.77	13.89	13.83	0-3	0
	1	49	13.69	13.77	13.80		0
	25	0	13.66	13.85	13.77		0
64QAM	25	12	13.66	13.86	13.74	0-3	0
	25	25	13.60	13.79	13.75		0
	50	0	13.63	13.83	13.80	0	
							0

Table 8-66
LTE Band 25 (PCS) Reduced Conducted Powers - 5 MHz Bandwidth

LTE Band 25 (PCS) 5 MHz Bandwidth							
Modulation	RB Size	RB Offset	Low Channel	Mid Channel	High Channel	MPR Allowed per 3GPP [dB]	MPR [dB]
			26065 (1852.5 MHz)	26365 (1882.5 MHz)	26665 (1912.5 MHz)		
			Conducted Power [dBm]				
QPSK	1	0	13.91	13.88	13.96	0	0
	1	12	13.93	13.90	14.05		0
	1	24	13.87	13.92	14.14		0
	12	0	13.98	14.00	14.10	0-1	0
	12	6	14.11	14.00	14.17		0
	12	13	14.00	14.06	14.16		0
16QAM	25	0	13.97	14.10	14.13	0-1	0
	1	0	14.20	14.23	14.36		0
	1	12	14.30	14.33	14.32		0
	1	24	14.13	14.30	14.34	0-2	0
	12	0	14.00	14.01	14.12		0
	12	6	14.12	14.08	14.20		0
64QAM	12	13	14.00	14.08	14.22	0-2	0
	25	0	13.95	14.08	14.15		0
	1	0	13.80	13.84	13.70		0-3
	1	12	13.95	13.91	13.80	0	
	1	24	13.90	14.11	13.78	0	
	64QAM	12	0	13.75	13.78	13.71	0-3
12		6	13.84	13.86	13.77	0	
12		13	13.86	13.89	13.77	0	
25		0	13.79	13.75	13.80	0	





FCC ID: A3LSMT867U		SAR EVALUATION REPORT		Approved by: Quality Manager
Document S/N: 1M1907300131-01-R1.A3L	Test Dates: 08/05/19 - 08/27/19	DUT Type: Portable Tablet	Page 53 of 126	

Table 8-67
LTE Band 25 (PCS) Reduced Conducted Powers - 3 MHz Bandwidth

LTE Band 25 (PCS) 3 MHz Bandwidth							
Modulation	RB Size	RB Offset	Low Channel	Mid Channel	High Channel	MPR Allowed per 3GPP [dB]	MPR [dB]
			26055 (1851.5 MHz)	26365 (1882.5 MHz)	26675 (1913.5 MHz)		
			Conducted Power [dBm]				
QPSK	1	0	13.90	13.85	13.97	0	0
	1	7	13.88	13.97	14.00		0
	1	14	13.90	13.95	14.04		0
	8	0	13.99	14.00	14.10	0-1	0
	8	4	14.03	14.07	14.17		0
	8	7	13.97	14.02	14.11		0
	15	0	14.00	14.00	14.05		0
16QAM	1	0	14.20	14.21	14.35	0-1	0
	1	7	14.21	14.07	14.40		0
	1	14	14.18	14.44	14.44		0
	8	0	14.00	14.02	14.15	0-2	0
	8	4	14.06	14.10	14.23		0
	8	7	14.06	14.10	14.17		0
	15	0	13.96	14.00	14.08		0
64QAM	1	0	13.70	13.76	13.69	0-2	0
	1	7	13.82	13.88	13.79		0
	1	14	13.78	13.92	13.80		0
	8	0	13.72	13.75	13.66	0-3	0
	8	4	13.78	13.89	13.75		0
	8	7	13.76	13.87	13.76		0
	15	0	13.70	13.72	13.73		0

Table 8-68
LTE Band 25 (PCS) Reduced Conducted Powers – 1.4 MHz Bandwidth

LTE Band 25 (PCS) 1.4 MHz Bandwidth							
Modulation	RB Size	RB Offset	Low Channel	Mid Channel	High Channel	MPR Allowed per 3GPP [dB]	MPR [dB]
			26047 (1850.7 MHz)	26365 (1882.5 MHz)	26683 (1914.3 MHz)		
			Conducted Power [dBm]				
QPSK	1	0	13.86	13.78	13.89	0	0
	1	2	13.91	14.00	14.00		0
	1	5	13.77	13.84	13.98		0
	3	0	13.83	13.81	13.94		0
	3	2	13.93	13.88	14.00		0
	3	3	13.86	13.83	13.97		0
	6	0	13.94	13.96	14.09	0-1	0
16QAM	1	0	14.15	14.25	14.32	0-1	0
	1	2	14.28	14.40	14.40		0
	1	5	14.11	14.23	14.32		0
	3	0	14.06	14.00	14.15		0
	3	2	14.10	14.18	14.21		0
	3	3	14.08	14.00	14.15		0
	6	0	14.00	14.02	14.18	0-2	0
64QAM	1	0	13.77	13.69	13.70	0-2	0
	1	2	13.78	13.87	13.75		0
	1	5	13.72	13.82	13.72		0
	3	0	13.71	13.72	13.74		0
	3	2	13.74	13.84	13.80		0
	3	3	13.73	13.81	13.75		0
	6	0	13.57	13.97	13.66	0-3	0

FCC ID: A3LSMT867U	 PCTEST ENGINEERING LABORATORY, INC.	SAR EVALUATION REPORT		Approved by: Quality Manager
Document S/N: 1M1907300131-01-R1.A3L	Test Dates: 08/05/19 - 08/27/19	DUT Type: Portable Tablet	Page 54 of 126	

8.2.2



LTE Band 7

Table 8-69
LTE Band 7 Maximum Conducted Powers - 20 MHz Bandwidth

LTE Band 7 20 MHz Bandwidth								
Modulation	RB Size	RB Offset	Low Channel	Mid Channel	High Channel	MPR Allowed per 3GPP [dB]	MPR [dB]	
			20850 (2510.0 MHz)	21100 (2535.0 MHz)	21350 (2560.0 MHz)			
			Conducted Power [dBm]					
QPSK	1	0	22.48	22.55	23.03	0	0	
	1	50	22.59	22.69	23.08		0	
	1	99	22.60	22.65	23.02		0	
	16QAM	50	0	21.63	21.70	22.22	0-1	1
		50	25	21.61	21.73	22.12		1
		50	50	21.65	21.76	22.06		1
		100	0	21.60	21.75	22.00		1
64QAM	1	0	22.08	21.93	22.30	0-1	1	
	1	50	22.07	21.92	22.35		1	
	1	99	22.19	22.09	22.38		1	
	16QAM	50	0	20.71	20.75	21.25	0-2	2
		50	25	20.64	20.72	21.12		2
		50	50	20.66	20.71	21.03		2
		100	0	20.98	20.74	21.10		2
64QAM	1	0	20.87	20.98	21.35	0-2	2	
	1	50	20.91	20.91	21.13		2	
	1	99	20.90	21.11	21.16		2	
	16QAM	50	0	19.94	19.71	20.23	0-3	3
		50	25	19.94	19.73	20.16		3
		50	50	19.72	19.77	20.10		3
		100	0	19.70	19.78	20.11		3

Table 8-70
LTE Band 7 Maximum Conducted Powers - 15 MHz Bandwidth

LTE Band 7 15 MHz Bandwidth								
Modulation	RB Size	RB Offset	Low Channel	Mid Channel	High Channel	MPR Allowed per 3GPP [dB]	MPR [dB]	
			20825 (2507.5 MHz)	21100 (2535.0 MHz)	21375 (2562.5 MHz)			
			Conducted Power [dBm]					
QPSK	1	0	22.41	22.53	23.04	0	0	
	1	36	22.37	22.51	23.02		0	
	1	74	22.34	22.70	22.89		0	
	16QAM	36	0	21.55	21.76	22.23	0-1	1
		36	18	21.60	21.78	22.17		1
		36	37	21.55	21.77	22.14		1
		75	0	21.55	21.77	22.19		1
64QAM	1	0	21.72	21.80	22.33	0-1	1	
	1	36	21.52	21.72	22.31		1	
	1	74	21.58	21.92	21.91		1	
	16QAM	36	0	20.56	20.72	21.22	0-2	2
		36	18	20.56	20.77	21.17		2
		36	37	20.56	20.73	21.21		2
		75	0	20.55	20.74	21.16		2
64QAM	1	0	20.68	20.86	21.30	0-2	2	
	1	36	20.60	20.78	20.88		2	
	1	74	20.57	20.93	21.14		2	
	16QAM	36	0	19.58	19.74	19.89	0-3	3
		36	18	19.61	19.78	20.22		3
		36	37	19.62	19.80	20.17		3
		75	0	19.53	19.77	20.11		3

FCC ID: A3LSMT867U		SAR EVALUATION REPORT		Approved by: Quality Manager
Document S/N: 1M1907300131-01-R1.A3L	Test Dates: 08/05/19 - 08/27/19	DUT Type: Portable Tablet	Page 55 of 126	

**Table 8-71
LTE Band 7 Maximum Conducted Powers - 10 MHz Bandwidth**

LTE Band 7 10 MHz Bandwidth							
Modulation	RB Size	RB Offset	Low Channel	Mid Channel	High Channel	MPR Allowed per 3GPP [dB]	MPR [dB]
			20800 (2505.0 MHz)	21100 (2535.0 MHz)	21400 (2565.0 MHz)		
			Conducted Power [dBm]				
QPSK	1	0	22.26	22.48	23.02	0	0
	1	25	22.29	22.49	22.97		0
	1	49	22.26	22.56	22.93		0
	25	0	21.41	21.63	22.12	0-1	1
	25	12	21.43	21.65	22.03		1
	25	25	21.40	21.62	21.99		1
16QAM	50	0	21.42	21.64	22.08	0-1	1
	1	0	21.17	21.69	22.20		1
	1	25	21.53	21.70	21.90		1
	1	49	21.46	21.81	22.08	0-2	1
	25	0	20.46	20.60	21.11		2
	25	12	20.42	20.76	21.05		2
64QAM	25	25	20.38	20.62	21.02	0-2	2
	50	0	20.42	20.63	21.08		2
	1	0	20.51	20.71	20.99		0-2
	1	25	20.55	20.72	21.44	2	
	1	49	20.43	20.72	21.15	2	
	64QAM	25	0	19.46	19.64	19.80	0-3
25		12	19.43	19.67	20.09	3	
25		25	19.42	19.68	20.07	3	
50		0	19.44	19.66	20.11	3	

**Table 8-72
LTE Band 7 Maximum Conducted Powers - 5 MHz Bandwidth**

LTE Band 7 5 MHz Bandwidth							
Modulation	RB Size	RB Offset	Low Channel	Mid Channel	High Channel	MPR Allowed per 3GPP [dB]	MPR [dB]
			20775 (2502.5 MHz)	21100 (2535.0 MHz)	21425 (2567.5 MHz)		
			Conducted Power [dBm]				
QPSK	1	0	22.35	22.42	22.96	0	0
	1	12	22.47	22.57	23.07		0
	1	24	22.47	22.65	23.03		0
	12	0	21.51	21.58	22.08	0-1	1
	12	6	21.62	21.66	22.21		1
	12	13	21.57	21.71	22.20		1
16QAM	25	0	21.56	21.69	22.12	0-1	1
	1	0	21.60	21.66	22.25		1
	1	12	21.69	21.86	22.35		1
	1	24	21.63	21.90	22.33	0-2	1
	12	0	20.51	20.61	21.12		2
	12	6	20.63	20.68	21.26		2
64QAM	12	13	20.61	20.74	21.17	0-2	2
	25	0	20.55	20.70	21.11		2
	1	0	20.52	20.55	21.11		0-2
	1	12	20.74	20.82	21.34	2	
	1	24	20.69	20.85	21.44	2	
	64QAM	12	0	19.50	19.64	20.19	0-3
12		6	19.66	19.71	20.27	3	
12		13	19.58	19.74	20.25	3	
25		0	19.58	19.69	20.14	3	





FCC ID: A3LSMT867U		SAR EVALUATION REPORT		Approved by: Quality Manager
Document S/N: 1M1907300131-01-R1.A3L	Test Dates: 08/05/19 - 08/27/19	DUT Type: Portable Tablet	Page 56 of 126	

Table 8-73
LTE Band 7 Reduced Conducted Powers - 20 MHz Bandwidth

LTE Band 7 20 MHz Bandwidth							
Modulation	RB Size	RB Offset	Low Channel	Mid Channel	High Channel	MPR Allowed per 3GPP [dB]	MPR [dB]
			20850 (2510.0 MHz)	21100 (2535.0 MHz)	21350 (2560.0 MHz)		
			Conducted Power [dBm]				
QPSK	1	0	13.89	13.88	14.21	0	0
	1	50	13.79	13.75	14.14		0
	1	99	13.90	13.86	14.13		0
	50	0	14.00	13.97	14.27	0-1	0
	50	25	13.98	13.94	14.32		0
	50	50	13.92	13.96	14.30		0
16QAM	100	0	13.85	13.95	14.19	0-1	0
	1	0	14.24	14.37	14.48		0
	1	50	14.09	14.25	14.42		0
	1	99	14.13	14.29	14.50	0-2	0
	50	0	13.86	13.93	14.28		0
	50	25	13.83	13.97	14.26		0
64QAM	50	50	13.88	13.95	14.23	0-2	0
	100	0	13.83	13.97	14.26		0
	1	0	14.09	14.17	14.44		0-3
	1	50	14.04	14.04	14.41	0	
	1	99	13.98	14.16	14.42	0	
	50	0	13.99	14.07	14.47	0	
50	25	14.02	14.02	14.38	0		
50	50	14.00	14.04	14.27	0		
100	0	13.99	14.05	14.31	0		

Table 8-74
LTE Band 7 Reduced Conducted Powers - 15 MHz Bandwidth

LTE Band 7 15 MHz Bandwidth							
Modulation	RB Size	RB Offset	Low Channel	Mid Channel	High Channel	MPR Allowed per 3GPP [dB]	MPR [dB]
			20825 (2507.5 MHz)	21100 (2535.0 MHz)	21375 (2562.5 MHz)		
			Conducted Power [dBm]				
QPSK	1	0	13.41	13.90	14.28	0	0
	1	36	13.25	13.91	14.28		0
	1	74	13.21	13.94	14.24		0
	36	0	13.52	13.95	14.40	0-1	0
	36	18	13.49	14.05	14.46		0
	36	37	13.48	14.04	14.45		0
16QAM	75	0	13.50	14.00	14.44	0-1	0
	1	0	13.64	14.05	14.50		0
	1	36	13.65	14.25	14.43		0-2
	1	74	13.55	14.10	14.50	0	
	36	0	13.58	14.01	14.39	0	
	36	18	13.57	14.00	14.42	0	
64QAM	36	37	13.51	14.00	14.44	0-2	0
	75	0	13.56	14.03	14.40		0
	1	0	13.82	14.13	14.50		0-3
	1	36	13.69	14.00	14.45	0	
	1	74	13.73	14.21	14.46	0	
	36	0	13.75	14.00	14.38	0	
36	18	13.77	14.04	14.31	0		
36	37	13.70	14.02	14.29	0		
75	0	13.74	14.00	14.27	0		



FCC ID: A3LSMT867U	 PCTEST ENGINEERING LABORATORY, INC.	SAR EVALUATION REPORT		Approved by: Quality Manager
Document S/N: 1M1907300131-01-R1.A3L	Test Dates: 08/05/19 - 08/27/19	DUT Type: Portable Tablet	Page 57 of 126	

**Table 8-75
LTE Band 7 Reduced Conducted Powers - 10 MHz Bandwidth**

LTE Band 7 10 MHz Bandwidth							
Modulation	RB Size	RB Offset	Low Channel	Mid Channel	High Channel	MPR Allowed per 3GPP [dB]	MPR [dB]
			20800 (2505.0 MHz)	21100 (2535.0 MHz)	21400 (2565.0 MHz)		
			Conducted Power [dBm]				
QPSK	1	0	13.43	13.45	14.03	0	0
	1	25	13.38	13.52	14.03		0
	1	49	13.38	13.55	13.97		0
	25	0	13.49	13.59	14.09	0-1	0
	25	12	13.50	13.63	14.12		0
	25	25	13.45	13.60	14.09		0
16QAM	50	0	13.48	13.63	14.10	0-1	0
	1	0	13.51	13.85	14.36		0
	1	25	13.73	13.82	14.35		0
	1	49	13.63	13.89	14.28	0-2	0
	25	0	13.50	13.57	14.13		0
	25	12	13.53	13.63	14.11		0
64QAM	25	25	13.47	13.62	14.06	0-2	0
	50	0	13.48	13.65	14.02		0
	1	0	13.82	13.80	14.28		0-3
	1	25	13.71	13.77	14.28	0	
	1	49	13.61	13.80	14.23	0	
	25	0	13.65	13.75	14.21	0	
25	12	13.60	13.73	14.18	0		
25	25	13.51	13.73	14.16	0		
50	0	13.61	13.77	14.18	0		

**Table 8-76
LTE Band 7 Reduced Conducted Powers - 5 MHz Bandwidth**

LTE Band 7 5 MHz Bandwidth							
Modulation	RB Size	RB Offset	Low Channel	Mid Channel	High Channel	MPR Allowed per 3GPP [dB]	MPR [dB]
			20775 (2502.5 MHz)	21100 (2535.0 MHz)	21425 (2567.5 MHz)		
			Conducted Power [dBm]				
QPSK	1	0	13.40	13.47	14.07	0	0
	1	12	13.42	13.50	14.04		0
	1	24	13.36	13.47	13.95		0
	12	0	13.58	13.61	14.09	0-1	0
	12	6	13.57	13.60	14.20		0
	12	13	13.51	13.61	14.11		0
16QAM	25	0	13.52	13.58	14.06	0-1	0
	1	0	13.78	13.88	14.35		0
	1	12	13.81	13.89	14.36		0
	1	24	13.65	13.80	14.31	0-2	0
	12	0	13.61	13.66	14.17		0
	12	6	13.62	13.69	14.21		0
64QAM	12	13	13.59	13.63	14.15	0-2	0
	25	0	13.56	13.65	14.06		0
	1	0	13.63	13.75	14.22		0-3
	1	12	13.78	13.90	14.35	0	
	1	24	13.74	13.94	14.31	0	
	12	0	13.61	13.70	14.20	0	
12	6	13.68	13.77	14.34	0		
12	13	13.75	13.82	14.32	0		
25	0	13.68	13.75	14.27	0		

FCC ID: A3LSMT867U	 PCTEST ENGINEERING LABORATORY, INC.	SAR EVALUATION REPORT		Approved by: Quality Manager
Document S/N: 1M1907300131-01-R1.A3L	Test Dates: 08/05/19 - 08/27/19	DUT Type: Portable Tablet	Page 58 of 126	

8.2.1

LTE Band 41

Table 8-77
LTE Band 41 PC3 Maximum Conducted Powers - 20 MHz Bandwidth

LTE Band 41 20 MHz Bandwidth									
Modulation	RB Size	RB Offset	Low Channel	Low-Mid Channel	Mid Channel	Mid-High Channel	High Channel	MPR Allowed per 3GPP [dB]	MPR [dB]
			39750 (2506.0 MHz)	40185 (2549.5 MHz)	40620 (2593.0 MHz)	41055 (2636.5 MHz)	41490 (2680.0 MHz)		
			Conducted Power [dBm]						
QPSK	1	0	23.89	23.84	24.14	24.09	23.70	0	0
	1	50	23.91	23.82	24.16	23.91	23.83		0
	1	99	23.87	23.70	24.06	23.87	23.91		0
	50	0	23.01	23.02	23.33	23.22	22.98	0-1	1
	50	25	23.01	23.00	23.35	23.17	23.04		1
	50	50	22.98	22.89	23.29	23.14	23.09		1
16QAM	100	0	23.00	22.98	23.29	23.11	23.05	0-1	1
	1	0	22.99	23.00	23.34	23.16	22.83		1
	1	50	22.81	22.92	23.30	23.06	22.88		1
	1	99	22.75	22.89	23.25	22.92	23.03	0-2	1
	50	0	22.07	22.07	22.30	22.23	22.00		2
	50	25	22.02	22.02	22.32	22.16	22.07		2
64QAM	50	50	22.03	21.99	22.29	22.02	22.11	0-2	2
	100	0	22.04	22.04	22.29	22.14	22.06		2
	1	0	21.57	21.64	21.73	21.75	21.40		0-2
	1	50	21.58	21.54	21.73	21.75	21.48	2	
	1	99	21.68	21.56	21.62	21.65	21.58	0-3	
	50	0	21.06	21.08	21.28	21.21	21.00		3
50	25	21.04	21.02	21.31	21.30	21.04	3		
50	50	21.00	20.99	21.27	21.25	21.08	0-3	3	
100	0	20.99	21.05	21.31	21.30	21.06		3	

Table 8-78
LTE Band 41 PC3 Maximum Conducted Powers - 15 MHz Bandwidth

LTE Band 41 15 MHz Bandwidth										
Modulation	RB Size	RB Offset	Low Channel	Low-Mid Channel	Mid Channel	Mid-High Channel	High Channel	MPR Allowed per 3GPP [dB]	MPR [dB]	
			39750 (2506.0 MHz)	40185 (2549.5 MHz)	40620 (2593.0 MHz)	41055 (2636.5 MHz)	41490 (2680.0 MHz)			
			Conducted Power [dBm]							
QPSK	1	0	23.88	23.89	24.10	24.00	23.84	0	0	
	1	36	23.74	23.79	24.10	23.89	23.88		0	
	1	74	23.72	23.72	24.09	23.75	24.03		0	
	36	0	22.92	22.96	23.26	23.13	23.00	0-1	1	
	36	18	22.94	23.03	23.32	23.10	23.10		1	
	36	37	22.90	22.92	23.28	23.02	23.12		1	
16QAM	75	0	22.93	22.99	23.31	23.11	23.10	0-1	1	
	1	0	22.94	22.95	23.25	23.11	23.00		1	
	1	36	22.78	22.94	23.20	23.00	23.05		0-1	1
	1	74	22.77	22.82	23.16	22.87	23.17	1		
	36	0	21.95	21.98	22.26	22.10	22.03	0-2		2
	36	18	21.94	22.02	22.28	22.08	22.11		2	
36	37	21.91	21.94	22.27	21.99	22.14	2			
64QAM	75	0	21.94	21.98	22.28	22.07	22.07	0-2	2	
	1	0	21.61	21.65	21.89	21.80	21.55		0-2	2
	1	36	21.41	21.49	21.83	21.61	21.63			2
	1	74	21.44	21.48	21.77	21.50	21.77	0-3		2
	36	0	20.91	20.98	21.25	21.10	20.98		3	
	36	18	20.91	20.96	21.27	21.08	21.08		3	
36	37	20.88	20.93	21.25	20.98	21.10	0-3	3		
75	0	20.95	21.01	21.30	21.09	21.10		3		



FCC ID: A3LSMT867U		SAR EVALUATION REPORT		Approved by: Quality Manager
Document S/N: 1M1907300131-01-R1.A3L	Test Dates: 08/05/19 - 08/27/19	DUT Type: Portable Tablet	Page 59 of 126	

Table 8-79
LTE Band 41 PC3 Maximum Conducted Powers - 10 MHz Bandwidth

LTE Band 41 10 MHz Bandwidth									
Modulation	RB Size	RB Offset	Low Channel	Low-Mid Channel	Mid Channel	Mid-High Channel	High Channel	MPR Allowed per 3GPP [dB]	MPR [dB]
			39750 (2506.0 MHz)	40185 (2549.5 MHz)	40620 (2593.0 MHz)	41055 (2636.5 MHz)	41490 (2680.0 MHz)		
			Conducted Power [dBm]						
QPSK	1	0	23.68	23.72	24.08	23.87	23.89	0	0
	1	25	23.69	23.78	24.02	23.81	23.82		0
	1	49	23.54	23.70	24.01	23.84	23.83		0
	25	0	22.87	22.95	23.23	23.02	23.00	0-1	1
	25	12	22.85	22.93	23.25	23.00	23.00		1
	25	25	22.78	22.92	23.17	22.94	22.94		1
16QAM	50	0	22.86	22.95	23.24	23.01	23.01	0-1	1
	1	0	22.77	22.87	23.17	22.89	22.89		1
	1	25	22.77	22.90	23.20	22.98	23.00		1
	1	49	22.66	22.82	23.10	22.87	22.87	0-2	1
	25	0	21.81	21.92	22.19	21.93	21.93		2
	25	12	21.77	21.90	22.16	21.94	21.91		2
64QAM	25	25	21.73	21.85	22.08	21.90	21.87	0-2	2
	50	0	21.88	21.97	22.22	22.04	22.01		2
	1	0	21.49	21.60	21.84	21.70	21.65		0-3
	1	25	21.39	21.50	21.76	21.56	21.55	2	
	1	49	21.29	21.50	21.76	21.55	21.54	2	
	25	0	20.91	21.02	21.25	21.06	21.06	0-3	3
25	12	20.88	21.01	21.25	21.02	21.03	3		
25	25	20.80	20.96	21.19	21.00	21.02	3		
50	0	20.87	20.98	21.24	21.03	21.03	3		

Table 8-80
LTE Band 41 PC3 Maximum Conducted Powers - 5 MHz Bandwidth

LTE Band 41 5 MHz Bandwidth									
Modulation	RB Size	RB Offset	Low Channel	Low-Mid Channel	Mid Channel	Mid-High Channel	High Channel	MPR Allowed per 3GPP [dB]	MPR [dB]
			39750 (2506.0 MHz)	40185 (2549.5 MHz)	40620 (2593.0 MHz)	41055 (2636.5 MHz)	41490 (2680.0 MHz)		
			Conducted Power [dBm]						
QPSK	1	0	23.76	23.83	24.13	23.89	23.85	0	0
	1	12	23.71	23.89	24.14	23.92	23.94		0
	1	24	23.98	23.96	24.17	23.93	23.90		0
	12	0	22.82	22.89	23.20	23.00	22.96	0-1	1
	12	6	22.99	22.98	23.28	23.05	23.50		1
	12	13	22.84	22.98	23.24	23.00	23.00		1
16QAM	25	0	22.86	23.00	23.25	23.04	22.95	0-1	1
	1	0	22.89	22.96	23.22	23.00	23.01		1
	1	12	22.85	23.00	23.26	23.03	23.04		1
	1	24	22.79	22.96	23.22	23.01	23.06	0-2	1
	12	0	21.91	21.96	22.22	21.97	21.97		2
	12	6	21.89	22.01	22.29	22.04	22.06		2
64QAM	12	13	21.84	22.00	22.25	22.03	22.02	0-2	2
	25	0	21.76	21.90	22.18	21.93	21.89		2
	1	0	21.47	21.56	21.87	21.66	21.59		0-3
	1	12	21.40	21.64	21.85	21.63	21.63	2	
	1	24	21.46	21.60	21.91	21.67	21.65	2	
	12	0	20.92	20.96	21.20	20.96	20.95	0-3	3
12	6	20.91	21.04	21.32	21.06	21.10	3		
12	13	20.90	21.03	21.25	21.03	21.06	3		
25	0	20.85	21.03	21.29	21.08	20.99	3		



FCC ID: A3LSMT867U	 PCTEST ENGINEERING LABORATORY, INC.	SAR EVALUATION REPORT		Approved by: Quality Manager
Document S/N: 1M1907300131-01-R1.A3L	Test Dates: 08/05/19 - 08/27/19	DUT Type: Portable Tablet	Page 60 of 126	

Table 8-81
LTE Band 41 PC3 Reduced Conducted Powers - 20 MHz Bandwidth

LTE Band 41 20 MHz Bandwidth										
Modulation	RB Size	RB Offset	Low Channel	Low-Mid Channel	Mid Channel	Mid-High Channel	High Channel	MPR Allowed per 3GPP [dB]	MPR [dB]	
			39750 (2506.0 MHz)	40185 (2549.5 MHz)	40620 (2593.0 MHz)	41055 (2636.5 MHz)	41490 (2680.0 MHz)			
			Conducted Power [dBm]							
QPSK	1	0	13.35	13.43	13.72	13.43	13.25	0	0	
	1	50	13.24	13.38	13.53	13.35	13.18		0	
	1	99	13.26	13.43	13.41	13.34	13.10		0	
	16QAM	50	0	13.37	13.51	13.75	13.48	13.40	0-1	0
		50	25	13.38	13.56	13.66	13.46	13.35		0
		50	50	13.38	13.57	13.57	13.47	13.33		0
		64QAM	100	0	13.36	13.51	13.65	13.47	13.36	0-1
1			0	13.50	13.42	13.85	13.61	13.52	0	
1			50	13.40	13.36	13.67	13.47	13.49	0	
16QAM	1		99	13.31	13.40	13.51	13.50	13.35	0-2	0
	50		0	13.38	13.37	13.80	13.53	13.49		0
	50		25	13.39	13.42	13.72	13.49	13.51		0
	64QAM		50	50	13.33	13.41	13.62	13.51	13.42	0-2
		100	0	13.41	13.42	13.74	13.53	13.50	0	
		1	0	13.21	13.14	13.58	13.32	13.52	0	
64QAM		1	50	13.10	13.07	13.39	13.17	13.48	0-2	0
		1	99	13.01	13.09	13.23	13.11	13.35		0
		50	0	13.33	13.33	13.76	13.45	13.50		0
		64QAM	50	25	13.34	13.37	13.68	13.48	13.51	0-3
	50		50	13.29	13.37	13.58	13.45	13.42	0	
	100		0	13.42	13.43	13.76	13.55	13.50	0	

Table 8-82
LTE Band 41 PC3 Reduced Conducted Powers - 15 MHz Bandwidth

LTE Band 41 15 MHz Bandwidth										
Modulation	RB Size	RB Offset	Low Channel	Low-Mid Channel	Mid Channel	Mid-High Channel	High Channel	MPR Allowed per 3GPP [dB]	MPR [dB]	
			39750 (2506.0 MHz)	40185 (2549.5 MHz)	40620 (2593.0 MHz)	41055 (2636.5 MHz)	41490 (2680.0 MHz)			
			Conducted Power [dBm]							
QPSK	1	0	13.28	13.15	13.60	13.33	13.24	0	0	
	1	36	13.15	13.07	13.42	13.20	13.21		0	
	1	74	13.16	13.14	13.35	13.25	13.22		0	
	16QAM	36	0	13.34	13.32	13.70	13.42	13.43	0-1	0
		36	18	13.37	13.38	13.68	13.44	13.43		0
		36	37	13.32	13.37	13.57	13.45	13.39		0
		64QAM	75	0	13.32	13.39	13.62	13.43	13.39	0-1
1			0	13.52	13.44	13.89	13.56	13.48	0	
1			36	13.35	13.35	13.71	13.43	13.47	0	
16QAM	1		74	13.33	13.42	13.58	13.47	13.44	0-2	0
	36		0	13.41	13.35	13.76	13.50	13.51		0
	36		18	13.41	13.43	13.70	13.49	13.50		0
	64QAM		36	37	13.37	13.41	13.64	13.51	13.45	0-2
		75	0	13.39	13.40	13.68	13.49	13.47	0	
		1	0	13.22	13.14	13.59	13.30	13.18	0	
64QAM		1	36	13.06	13.06	13.42	13.15	13.19	0-2	0
		1	74	13.05	13.14	13.30	13.19	13.14		0
		36	0	13.38	13.33	13.73	13.48	13.48		0
		64QAM	36	18	13.33	13.38	13.68	13.46	13.48	0-3
	36		37	13.35	13.40	13.61	13.49	13.41	0	
	75		0	13.40	13.39	13.68	13.48	13.47	0	



FCC ID: A3LSMT867U	 PCTEST ENGINEERING LABORATORY, INC.	SAR EVALUATION REPORT	 SAMSUNG	Approved by: Quality Manager
Document S/N: 1M1907300131-01-R1.A3L	Test Dates: 08/05/19 - 08/27/19	DUT Type: Portable Tablet	Page 61 of 126	

Table 8-83
LTE Band 41 PC3 Reduced Conducted Powers - 10 MHz Bandwidth

LTE Band 41 10 MHz Bandwidth									
Modulation	RB Size	RB Offset	Low Channel	Low-Mid Channel	Mid Channel	Mid-High Channel	High Channel	MPR Allowed per 3GPP [dB]	MPR [dB]
			39750 (2506.0 MHz)	40185 (2549.5 MHz)	40620 (2593.0 MHz)	41055 (2636.5 MHz)	41490 (2680.0 MHz)		
			Conducted Power [dBm]						
QPSK	1	0	13.11	13.03	13.36	13.19	13.16	0	0
	1	25	13.12	13.06	13.42	13.21	13.24		0
	1	49	13.22	13.21	13.27	13.04	13.11		0
	25	0	13.29	13.23	13.50	13.35	13.10	0-1	0
	25	12	13.22	13.20	13.50	13.33	13.30		0
	25	25	13.18	13.17	13.48	13.30	13.27		0
16QAM	50	0	13.23	13.22	13.50	13.33	13.29	0-1	0
	1	0	13.31	13.32	13.60	13.43	13.40		0
	1	25	13.37	13.31	13.65	13.45	13.47		0
	1	49	13.23	13.21	13.50	13.30	13.34	0-2	0
	25	0	13.24	13.20	13.54	13.33	13.31		0
	25	12	13.21	13.17	13.50	13.29	13.29		0
64QAM	25	25	13.14	13.15	13.46	13.28	13.27	0-2	0
	50	0	13.30	13.27	13.59	13.38	13.37		0
	1	0	13.03	13.02	13.34	13.15	13.11		0-3
	1	25	13.07	13.07	13.36	13.15	13.17	0	
	1	49	12.94	12.91	13.22	12.99	13.04	0	
	25	0	13.27	13.22	13.57	13.35	13.34	0	
25	12	13.26	13.21	13.53	13.33	13.32	0		
25	25	13.17	13.19	13.49	13.29	13.28	0		
50	0	13.26	13.23	13.54	13.33	13.33	0		

Table 8-84
LTE Band 41 PC3 Reduced Conducted Powers - 5 MHz Bandwidth

LTE Band 41 5 MHz Bandwidth									
Modulation	RB Size	RB Offset	Low Channel	Low-Mid Channel	Mid Channel	Mid-High Channel	High Channel	MPR Allowed per 3GPP [dB]	MPR [dB]
			39750 (2506.0 MHz)	40185 (2549.5 MHz)	40620 (2593.0 MHz)	41055 (2636.5 MHz)	41490 (2680.0 MHz)		
			Conducted Power [dBm]						
QPSK	1	0	13.14	13.05	13.32	13.10	13.16	0	0
	1	12	13.08	13.08	13.30	13.13	13.21		0
	1	24	13.16	13.05	13.29	13.20	13.15		0
	12	0	13.21	13.21	13.46	13.21	13.30	0-1	0
	12	6	13.29	13.22	13.32	13.26	13.33		0
	12	13	13.27	13.26	13.40	13.20	13.29		0
16QAM	25	0	13.22	13.26	13.44	13.25	13.29	0-1	0
	1	0	13.47	13.25	13.58	13.36	13.44		0
	1	12	13.46	13.30	13.63	13.38	13.45		0
	1	24	13.40	13.29	13.56	13.47	13.40	0-2	0
	12	0	13.26	13.30	13.55	13.33	13.38		0
	12	6	13.32	13.22	13.46	13.38	13.43		0
64QAM	12	13	13.32	13.27	13.48	13.36	13.35	0-2	0
	25	0	13.20	13.17	13.42	13.23	13.27		0
	1	0	13.11	12.97	13.30	13.07	13.14		0-3
	1	12	13.15	13.01	13.23	13.18	13.17	0	
	1	24	12.99	12.96	13.35	13.11	13.11	0	
	12	0	13.30	13.25	13.51	13.32	13.33	0	
12	6	13.25	13.32	13.56	13.33	13.40	0		
12	13	13.21	13.24	13.53	13.34	13.30	0		
25	0	13.24	13.19	13.45	13.25	13.30	0		



FCC ID: A3LSMT867U	 PCTEST ENGINEERING LABORATORY, INC.	SAR EVALUATION REPORT		Approved by: Quality Manager
Document S/N: 1M1907300131-01-R1.A3L	Test Dates: 08/05/19 - 08/27/19	DUT Type: Portable Tablet	Page 62 of 126	

Table 8-85
LTE Band 41 PC2 Maximum Conducted Powers - 20 MHz Bandwidth

LTE Band 41 20 MHz Bandwidth									
Modulation	RB Size	RB Offset	Low Channel	Low-Mid Channel	Mid Channel	Mid-High Channel	High Channel	MPR Allowed per 3GPP [dB]	MPR [dB]
			39750 (2506.0 MHz)	40185 (2549.5 MHz)	40620 (2593.0 MHz)	41055 (2636.5 MHz)	41490 (2680.0 MHz)		
			Conducted Power [dBm]						
QPSK	1	0	26.66	26.73	27.05	26.87	26.67	0	0
	1	50	26.58	26.72	27.02	26.76	26.76		0
	1	99	26.54	26.69	27.00	26.50	26.87		0
	50	0	25.78	25.95	26.20	26.02	25.96	0-1	1
	50	25	25.83	25.95	26.22	26.00	26.01		1
	50	50	25.83	25.87	26.14	25.89	26.07		1
16QAM	100	0	25.76	25.91	26.13	25.98	25.99	0-1	1
	1	0	26.00	26.04	26.32	26.17	26.07		1
	1	50	25.90	26.06	26.26	26.07	26.10		1
	1	99	25.87	26.02	26.10	25.82	26.18	0-2	2
	50	0	24.82	24.98	25.21	25.07	24.97		2
	50	25	24.84	24.97	25.21	24.98	25.03		2
64QAM	50	50	24.82	25.02	25.16	24.89	25.08	0-2	2
	100	0	24.83	24.96	25.16	24.98	25.02		2
	1	0	24.90	24.90	25.19	25.09	24.90		0-3
	1	50	24.78	24.96	25.15	24.97	24.99	2	
	1	99	24.77	24.88	25.00	24.74	25.10	2	
	50	0	23.53	23.68	23.92	23.78	23.68	0-3	3
50	25	23.58	23.67	23.93	23.72	23.74	3		
50	50	23.54	23.60	23.85	23.61	23.79	3		
100	0	23.49	23.61	23.83	23.63	23.68	3		

Table 8-86
LTE Band 41 PC2 Maximum Conducted Powers - 15 MHz Bandwidth

LTE Band 41 15 MHz Bandwidth										
Modulation	RB Size	RB Offset	Low Channel	Low-Mid Channel	Mid Channel	Mid-High Channel	High Channel	MPR Allowed per 3GPP [dB]	MPR [dB]	
			39750 (2506.0 MHz)	40185 (2549.5 MHz)	40620 (2593.0 MHz)	41055 (2636.5 MHz)	41490 (2680.0 MHz)			
			Conducted Power [dBm]							
QPSK	1	0	26.74	26.75	27.03	26.74	26.73	0	0	
	1	36	26.63	26.74	26.95	26.75	26.81		0	
	1	74	26.60	26.66	27.00	26.70	26.97		0	
	36	0	25.87	25.94	26.26	25.94	26.00	0-1	1	
	36	18	25.90	25.95	26.20	25.92	26.07		1	
	36	37	25.85	25.92	26.23	25.85	26.11		1	
16QAM	75	0	25.87	25.93	26.25	25.90	26.05	0-1	1	
	1	0	26.11	26.11	26.39	26.06	26.07		0-2	1
	1	36	25.99	26.10	26.34	26.05	26.16			1
	1	74	25.94	26.01	26.32	25.97	26.31	0-2		1
	36	0	24.92	24.96	25.24	24.94	25.01		2	
	36	18	24.87	25.00	25.31	24.96	25.08		2	
64QAM	36	37	24.87	24.91	25.25	24.84	25.09	0-2	2	
	75	0	24.90	24.95	25.27	24.89	25.04		2	
	1	0	24.70	24.83	25.14	24.78	24.79		0-3	2
	1	36	24.68	24.81	25.07	24.79	24.89	2		
	1	74	24.70	24.70	25.09	24.70	25.01	2		
	36	0	23.80	23.95	24.24	23.92	23.97	0-3	3	
36	18	23.90	23.97	24.28	23.93	24.05	3			
36	37	23.83	23.89	24.25	23.84	24.07	3			
75	0	23.77	23.94	24.25	23.89	24.09	3			



FCC ID: A3LSMT867U	 PCTEST ENGINEERING LABORATORY, INC.	SAR EVALUATION REPORT		Approved by: Quality Manager
Document S/N: 1M1907300131-01-R1.A3L	Test Dates: 08/05/19 - 08/27/19	DUT Type: Portable Tablet	Page 63 of 126	

Table 8-87
LTE Band 41 PC2 Maximum Conducted Powers - 10 MHz Bandwidth

LTE Band 41 10 MHz Bandwidth									
Modulation	RB Size	RB Offset	Low Channel	Low-Mid Channel	Mid Channel	Mid-High Channel	High Channel	MPR Allowed per 3GPP [dB]	MPR [dB]
			39750 (2506.0 MHz)	40185 (2549.5 MHz)	40620 (2593.0 MHz)	41055 (2636.5 MHz)	41490 (2680.0 MHz)		
			Conducted Power [dBm]						
QPSK	1	0	26.69	26.77	27.03	26.81	26.75	0	0
	1	25	26.66	26.74	27.01	26.74	26.74		0
	1	49	26.54	26.69	26.93	26.71	26.73		0
	25	0	25.81	25.92	26.20	25.95	25.93	0-1	1
	25	12	25.78	25.91	26.12	25.94	25.93		1
	25	25	25.72	25.86	26.10	25.92	25.89		1
16QAM	50	0	25.77	25.85	26.19	25.95	25.96	0-1	1
	1	0	25.97	26.07	26.32	26.10	26.10		1
	1	25	25.91	26.00	26.27	26.05	26.09		1
	1	49	25.85	26.00	26.34	26.04	26.10	0-2	1
	25	0	24.75	24.87	25.13	24.90	24.90		2
	25	12	24.70	24.86	25.09	24.91	24.89		2
64QAM	25	25	24.66	24.82	25.07	24.86	24.85	0-2	2
	50	0	24.80	24.95	25.31	24.98	24.95		2
	1	0	24.67	24.81	25.09	24.85	24.83		2
	1	25	24.65	24.77	25.02	24.81	24.85	0-2	2
	1	49	24.59	24.74	24.91	24.78	24.86		2
	25	0	23.82	23.98	24.27	24.03	24.03		0-3
	25	12	23.85	24.00	24.27	24.03	24.02	3	
	25	25	23.79	23.91	24.20	23.98	24.06	3	
50	0	23.70	23.93	24.20	23.98	23.98	3		

Table 8-88
LTE Band 41 PC2 Maximum Conducted Powers - 5 MHz Bandwidth

LTE Band 41 5 MHz Bandwidth									
Modulation	RB Size	RB Offset	Low Channel	Low-Mid Channel	Mid Channel	Mid-High Channel	High Channel	MPR Allowed per 3GPP [dB]	MPR [dB]
			39750 (2506.0 MHz)	40185 (2549.5 MHz)	40620 (2593.0 MHz)	41055 (2636.5 MHz)	41490 (2680.0 MHz)		
			Conducted Power [dBm]						
QPSK	1	0	26.69	26.70	27.01	26.81	26.83	0	0
	1	12	26.67	26.76	27.04	26.84	26.88		0
	1	24	26.68	26.76	27.01	26.82	26.86		0
	12	0	25.77	25.84	26.11	25.92	25.87	0-1	1
	12	6	25.81	25.96	26.24	25.98	25.98		1
	12	13	25.79	25.88	26.19	25.94	25.93		1
16QAM	25	0	25.80	25.94	26.17	26.00	25.90	0-1	1
	1	0	26.00	26.06	26.34	26.16	26.11		1
	1	12	25.96	26.11	26.39	26.16	26.20		1
	1	24	25.94	26.07	26.36	26.14	26.20	0-2	1
	12	0	24.87	24.91	25.19	24.94	24.95		2
	12	6	24.87	25.02	25.27	25.04	25.08		2
64QAM	12	13	24.82	24.96	25.26	25.00	25.02	0-2	2
	25	0	24.73	24.86	25.12	24.93	24.84		2
	1	0	24.68	24.80	25.08	24.87	24.85		0-2
	1	12	24.68	24.85	25.08	24.90	24.91	2	
	1	24	24.69	24.81	25.13	24.80	24.90	2	
	12	0	23.85	23.91	24.17	23.99	23.96	0-3	3
	12	6	23.89	24.00	24.25	24.09	23.99		3
	12	13	23.84	24.08	24.22	24.04	24.05		3
25	0	23.87	23.97	24.28	24.05	23.98	3		





FCC ID: A3LSMT867U	 PCTEST ENGINEERING LABORATORY, INC.	SAR EVALUATION REPORT	 SAMSUNG	Approved by: Quality Manager
Document S/N: 1M1907300131-01-R1.A3L	Test Dates: 08/05/19 - 08/27/19	DUT Type: Portable Tablet	Page 64 of 126	

Table 8-89
LTE Band 41 PC2 Reduced Conducted Powers - 20 MHz Bandwidth

LTE Band 41 20 MHz Bandwidth										
Modulation	RB Size	RB Offset	Low Channel	Low-Mid Channel	Mid Channel	Mid-High Channel	High Channel	MPR Allowed per 3GPP [dB]	MPR [dB]	
			39750 (2506.0 MHz)	40185 (2549.5 MHz)	40620 (2593.0 MHz)	41055 (2636.5 MHz)	41490 (2680.0 MHz)			
			Conducted Power [dBm]							
QPSK	1	0	13.36	13.49	13.95	13.63	13.60	0	0	
	1	50	13.34	13.45	13.80	13.50	13.52		0	
	1	99	13.33	13.44	13.54	13.41	13.34		0	
	16QAM	50	0	13.42	13.61	14.00	13.70	13.73	0-1	0
		50	25	13.47	13.65	13.91	13.71	13.71		0
		50	50	13.43	13.62	13.78	13.65	13.62		0
		64QAM	100	0	13.44	13.65	13.89	13.64	13.69	0-1
1			0	13.67	13.67	14.00	13.62	13.65	0	
1			50	13.68	13.60	13.92	13.54	13.54	0	
16QAM	1		99	13.44	13.72	13.63	13.47	13.44	0-2	0
	50		0	13.40	13.50	13.78	13.39	13.41		0
	50		25	13.40	13.51	13.67	13.38	13.46		0
	64QAM		50	50	13.36	13.46	13.57	13.41	13.43	0-2
		100	0	13.37	13.51	13.65	13.37	13.39	0	
		1	0	13.50	13.51	13.89	13.48	13.40	0	
64QAM		1	50	13.43	13.41	13.66	13.42	13.43	0-3	0
		1	99	13.39	13.44	13.48	13.36	13.38		0
		50	0	13.40	13.44	13.71	13.28	13.33		0
		64QAM	50	25	13.35	13.41	13.62	13.31	13.42	0-3
	50		50	13.30	13.40	13.43	13.34	13.35	0	
	100		0	13.40	13.49	13.70	13.40	13.49	0	

Table 8-90
LTE Band 41 PC2 Reduced Conducted Powers - 15 MHz Bandwidth

LTE Band 41 15 MHz Bandwidth										
Modulation	RB Size	RB Offset	Low Channel	Low-Mid Channel	Mid Channel	Mid-High Channel	High Channel	MPR Allowed per 3GPP [dB]	MPR [dB]	
			39750 (2506.0 MHz)	40185 (2549.5 MHz)	40620 (2593.0 MHz)	41055 (2636.5 MHz)	41490 (2680.0 MHz)			
			Conducted Power [dBm]							
QPSK	1	0	13.19	13.26	13.64	13.17	13.19	0	0	
	1	36	13.14	13.22	13.48	13.09	13.09		0	
	1	74	13.10	13.23	13.29	13.09	13.09		0	
	16QAM	36	0	13.20	13.36	13.68	13.24	13.30	0-1	0
		36	18	13.31	13.43	13.58	13.29	13.25		0
		36	37	13.30	13.40	13.50	13.25	13.31		0
		64QAM	75	0	13.32	13.34	13.59	13.29	13.37	0-1
1			0	13.59	13.66	14.00	13.57	13.59	0	
1			36	13.55	13.60	13.84	13.50	13.51	0	
16QAM	1		74	13.48	13.58	13.75	13.69	13.51	0-2	0
	36		0	13.33	13.42	13.70	13.22	13.34		0
	36		18	13.43	13.46	13.62	13.27	13.37		0
	64QAM		36	37	13.32	13.43	13.57	13.33	13.34	0-2
		75	0	13.38	13.51	13.66	13.32	13.31	0	
		1	0	13.46	13.50	13.85	13.50	13.50	0	
64QAM		1	36	13.39	13.33	13.69	13.37	13.35	0-3	0
		1	74	13.39	13.47	13.49	13.43	13.32		0
		36	0	13.32	13.33	13.80	13.35	13.26		0
		64QAM	36	18	13.44	13.47	13.63	13.38	13.28	0-3
	36		37	13.34	13.43	13.58	13.34	13.35	0	
	75		0	13.37	13.51	13.67	13.31	13.43	0	



FCC ID: A3LSMT867U	 PCTEST ENGINEERING LABORATORY, INC.	SAR EVALUATION REPORT	 SAMSUNG	Approved by: Quality Manager
Document S/N: 1M1907300131-01-R1.A3L	Test Dates: 08/05/19 - 08/27/19	DUT Type: Portable Tablet	Page 65 of 126	

**Table 8-91
LTE Band 41 PC2 Reduced Conducted Powers - 10 MHz Bandwidth**

LTE Band 41 10 MHz Bandwidth									
Modulation	RB Size	RB Offset	Low Channel	Low-Mid Channel	Mid Channel	Mid-High Channel	High Channel	MPR Allowed per 3GPP [dB]	MPR [dB]
			39750 (2506.0 MHz)	40185 (2549.5 MHz)	40620 (2593.0 MHz)	41055 (2636.5 MHz)	41490 (2680.0 MHz)		
			Conducted Power [dBm]						
QPSK	1	0	13.12	13.14	13.35	13.04	13.20	0	0
	1	25	13.13	13.14	13.28	13.04	13.12		0
	1	49	13.01	13.01	13.26	12.90	13.05		0
	25	0	13.18	13.32	13.50	13.20	13.18	0-1	0
	25	12	13.18	13.18	13.46	13.24	13.25		0
	25	25	13.16	13.24	13.49	13.13	13.19		0
16QAM	50	0	13.29	13.28	13.47	13.13	13.22	0-1	0
	1	0	13.48	13.56	13.83	13.45	13.53		0
	1	25	13.44	13.56	13.76	13.49	13.43		0
	1	49	13.40	13.46	13.72	13.43	13.43	0-2	0
	25	0	13.36	13.23	13.57	13.27	13.36		0
	25	12	13.27	13.33	13.57	13.18	13.33		0
64QAM	25	25	13.22	13.33	13.49	13.23	13.27	0-2	0
	50	0	13.26	13.38	13.55	13.24	13.35		0
	1	0	13.42	13.35	13.66	13.28	13.37		0
	1	25	13.17	13.39	13.58	13.26	13.29	0-2	0
	1	49	13.23	13.25	13.46	13.17	13.22		0
	25	0	13.26	13.28	13.50	13.19	13.31		0
64QAM	25	12	13.23	13.30	13.47	13.17	13.27	0-3	0
	25	25	13.16	13.26	13.43	13.09	13.21		0
	50	0	13.19	13.22	13.47	13.17	13.28		0

**Table 8-92
LTE Band 41 PC2 Reduced Conducted Powers - 5 MHz Bandwidth**

LTE Band 41 5 MHz Bandwidth									
Modulation	RB Size	RB Offset	Low Channel	Low-Mid Channel	Mid Channel	Mid-High Channel	High Channel	MPR Allowed per 3GPP [dB]	MPR [dB]
			39750 (2506.0 MHz)	40185 (2549.5 MHz)	40620 (2593.0 MHz)	41055 (2636.5 MHz)	41490 (2680.0 MHz)		
			Conducted Power [dBm]						
QPSK	1	0	13.08	13.08	13.23	12.93	13.11	0	0
	1	12	13.06	13.05	13.38	13.09	13.23		0
	1	24	13.07	13.02	13.21	13.00	13.06		0
	12	0	13.19	13.21	13.50	13.11	13.08	0-1	0
	12	6	13.21	13.33	13.38	13.08	13.31		0
	12	13	13.18	13.25	13.44	13.11	13.21		0
16QAM	25	0	13.24	13.26	13.44	13.12	13.23	0-1	0
	1	0	13.50	13.49	13.65	13.39	13.50		0
	1	12	13.55	13.58	13.73	13.43	13.55		0
	1	24	13.45	13.52	13.65	13.32	13.48	0-2	0
	12	0	13.27	13.42	13.47	13.16	13.32		0
	12	6	13.39	13.43	13.57	13.24	13.41		0
64QAM	12	13	13.27	13.37	13.53	13.24	13.40	0-2	0
	25	0	13.32	13.35	13.52	13.17	13.31		0
	1	0	13.29	13.36	13.52	13.24	13.33		0
	1	12	13.30	13.42	13.67	13.27	13.30	0-2	0
	1	24	13.31	13.37	13.50	13.16	13.41		0
	12	0	13.34	13.33	13.47	13.17	13.33		0-3
12	6	13.33	13.40	13.57	13.21	13.30	0		
12	13	13.24	13.35	13.42	13.13	13.37	0		
25	0	13.25	13.29	13.45	13.12	13.27	0		

FCC ID: A3LSMT867U	 PCTEST ENGINEERING LABORATORY, INC.	SAR EVALUATION REPORT		Approved by: Quality Manager
Document S/N: 1M1907300131-01-R1.A3L	Test Dates: 08/05/19 - 08/27/19	DUT Type: Portable Tablet	Page 66 of 126	

8.3 LTE Uplink Carrier Aggregation Conducted Powers

Table 8-93
LTE Band 66 Reduced Uplink Carrier Aggregation Conducted Powers

Combination	PCC								SCC								Power			
	PCC Band	PCC Bandwidth [MHz]	PCC (UL) Channel	PCC (UL) Frequency [MHz]	PCC (DL) Channel	PCC (DL) Frequency [MHz]	Modulation	PCC UL# RB	PCC UL RB Offset	SCC Band	SCC Bandwidth [MHz]	SCC (UL) Channel	SCC (UL) Frequency [MHz]	SCC (DL) Channel	SCC (DL) Frequency [MHz]	Modulation	SCC UL# RB	SCC UL RB Offset	LTE Tx.Power with UL CA Enabled (dBm)	LTE Single Carrier Tx Power (dBm)
CA_66C	LTE B66	20	132072	1720.0	66536	2120.0	QPSK	50	50	LTE B66	20	132270	1739.8	66734	2139.8	QPSK	50	0	14.40	14.14
CA_66B	LTE B66	10	132022	1715.0	66486	2115.0	QPSK	25	25	LTE B66	10	132121	1724.9	66585	2124.9	QPSK	25	0	14.24	13.98

Table 8-94
LTE Band 41 PC3 Reduced Uplink Carrier Aggregation Conducted Powers

Combination	PCC						SCC						Power			
	PCC Band	PCC Bandwidth [MHz]	PCC (UL/DL) Channel	PCC (UL/DL) Frequency [MHz]	Modulation	PCC UL# RB	PCC UL RB Offset	SCC Band	SCC Bandwidth [MHz]	SCC (UL/DL) Channel	SCC (UL/DL) Frequency [MHz]	Modulation	SCC UL# RB	SCC UL RB Offset	LTE Tx.Power with UL CA Enabled (dBm)	LTE Single Carrier Tx Power (dBm)
CA_41C	LTE B41 PC3	20	40620	2593.0	QPSK	1	0	LTE B41	20	40422	2573.2	QPSK	1	99	14.00	13.72

Table 8-95
LTE Band 41 PC2 Reduced Uplink Carrier Aggregation Conducted Powers

Combination	PCC						SCC						Power			
	PCC Band	PCC Bandwidth [MHz]	PCC (UL/DL) Channel	PCC (UL/DL) Frequency [MHz]	Modulation	PCC UL# RB	PCC UL RB Offset	SCC Band	SCC Bandwidth [MHz]	SCC (UL/DL) Channel	SCC (UL/DL) Frequency [MHz]	Modulation	SCC UL# RB	SCC UL RB Offset	LTE Tx.Power with UL CA Enabled (dBm)	LTE Single Carrier Tx Power (dBm)
CA_41C	LTE B41 PC2	20	40620	2593.0	QPSK	1	0	LTE B41 PC2	20	40422	2573.2	QPSK	1	99	14.00	13.95

Notes:

1. This device supports uplink carrier aggregation for LTE CA_66B, LTE CA_66C, and LTE CA_41C with a maximum of two component carriers. For intraband contiguous carrier aggregation scenarios, 3GPP 36.101 Table 6.2.2A-1 specifies that the aggregate maximum allowed output power is equivalent to the single carrier scenario. 3GPP 36.101 6.2.3A allows for several dB of MPR to be applied when non-contiguous RB allocation is implemented. The conducted powers and MPR settings in this device are permanently implemented per the above 3GPP requirements.
2. Per FCC Guidance, the output power with uplink CA active was measured for the configuration with the highest reported SAR with single carrier for each exposure condition. The power was measured with wideband signal integration over both component carriers.

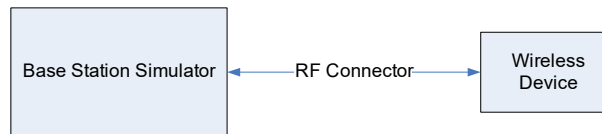



Figure 8-2
Power Measurement Setup

FCC ID: A3LSMT867U		SAR EVALUATION REPORT		Approved by: Quality Manager
Document S/N: 1M1907300131-01-R1.A3L	Test Dates: 08/05/19 - 08/27/19	DUT Type: Portable Tablet	Page 67 of 126	

8.4 WLAN Conducted Powers

Table 8-96
2.4 GHz WLAN Maximum Average RF Power – Ant 1

2.4GHz Conducted Power [dBm]				
Freq [MHz]	Channel	IEEE Transmission Mode		
		802.11b	802.11g	802.11n
		Average	Average	Average
2412	1	17.84	14.75	12.35
2417	2	19.22	16.27	17.42
2422	3	N/A	17.34	18.84
2437	6	19.67	17.66	18.90
2447	8	N/A	N/A	18.86
2452	9	N/A	17.43	16.57
2457	10	19.53	15.58	16.28
2462	11	18.12	14.12	13.25

Table 8-97
2.4 GHz WLAN Maximum Average RF Power – Ant 2

2.4GHz Conducted Power [dBm]				
Freq [MHz]	Channel	IEEE Transmission Mode		
		802.11b	802.11g	802.11n
		Average	Average	Average
2412	1	18.49	14.96	12.82
2417	2	19.73	16.37	17.32
2422	3	N/A	17.51	18.81
2437	6	19.65	17.62	18.95
2447	8	N/A	N/A	18.91
2452	9	N/A	17.54	16.64
2457	10	19.86	15.79	16.44
2462	11	18.25	13.75	13.28



FCC ID: A3LSMT867U	 PCTEST ENGINEERING LABORATORY, INC.	SAR EVALUATION REPORT	 SAMSUNG	Approved by: Quality Manager
Document S/N: 1M1907300131-01-R1.A3L	Test Dates: 08/05/19 - 08/27/19	DUT Type: Portable Tablet		Page 68 of 126

Table 8-98
5 GHz WLAN Maximum Average RF Power – Ant 1

5GHz (20MHz) Conducted Power [dBm]				
Freq [MHz]	Channel	IEEE Transmission Mode		
		802.11a	802.11n	802.11ac
		Average	Average	Average
5180	36	17.59	17.98	12.98
5200	40	17.58	17.96	12.44
5220	44	17.76	17.85	12.79
5240	48	17.73	17.93	12.71
5260	52	17.82	17.95	12.83
5280	56	17.62	17.83	12.98
5300	60	17.67	17.94	12.62
5320	64	17.81	17.92	12.77
5500	100	17.72	17.99	12.64
5600	120	17.38	17.84	12.94
5620	124	17.49	17.80	12.50
5720	144	17.40	17.61	12.46
5745	149	17.51	17.81	12.61
5785	157	17.77	17.94	12.76
5825	165	17.50	17.64	12.53

Table 8-99
5 GHz WLAN Maximum Average RF Power – Ant 2

5GHz (20MHz) Conducted Power [dBm]				
Freq [MHz]	Channel	IEEE Transmission Mode		
		802.11a	802.11n	802.11ac
		Average	Average	Average
5180	36	17.82	17.86	12.64
5200	40	17.61	17.95	12.91
5220	44	17.57	17.99	12.94
5240	48	17.93	17.94	12.90
5260	52	17.80	17.89	12.64
5280	56	17.93	17.97	12.85
5300	60	17.57	17.70	12.50
5320	64	17.71	17.85	12.55
5500	100	17.70	17.83	12.59
5600	120	17.64	17.65	12.51
5620	124	17.93	17.86	12.82
5720	144	17.96	17.93	12.53
5745	149	17.95	17.94	12.57
5785	157	17.95	17.96	12.57
5825	165	17.58	17.87	12.62



FCC ID: A3LSMT867U		SAR EVALUATION REPORT		Approved by: Quality Manager
Document S/N: 1M1907300131-01-R1.A3L	Test Dates: 08/05/19 - 08/27/19	DUT Type: Portable Tablet	Page 69 of 126	

Table 8-100
2.4 GHz WLAN Reduced Average RF Power – Ant 1

2.4GHz Conducted Power [dBm]				
Freq [MHz]	Channel	IEEE Transmission Mode		
		802.11b	802.11g	802.11n
		Average	Average	Average
2412	1	12.84	12.86	12.74
2437	6	12.80	12.84	12.75
2462	11	13.46	13.36	13.24

Table 8-101
2.4 GHz WLAN Reduced Average RF Power – Ant 2



2.4GHz Conducted Power [dBm]				
Freq [MHz]	Channel	IEEE Transmission Mode		
		802.11b	802.11g	802.11n
		Average	Average	Average
2412	1	13.03	13.00	12.90
2437	6	12.94	12.77	12.63
2462	11	12.87	12.84	12.67

Table 8-102
5 GHz WLAN Reduced Average RF Power – Ant 1

5GHz (80MHz) Conducted Power [dBm]		
Freq [MHz]	Channel	IEEE Transmission Mode
		802.11ac
		Average
5210	42	8.99
5290	58	8.95
5530	106	8.96
5610	122	8.80
5690	138	8.75
5775	155	8.91

Table 8-103
5 GHz WLAN Reduced Average RF Power – Ant 2

5GHz (80MHz) Conducted Power [dBm]		
Freq [MHz]	Channel	IEEE Transmission Mode
		802.11ac
		Average
5210	42	8.99
5290	58	9.00
5530	106	8.92
5610	122	8.88
5690	138	8.99
5775	155	9.00

FCC ID: A3LSMT867U	 PCTEST ENGINEERING LABORATORY, INC.	SAR EVALUATION REPORT		Approved by: Quality Manager
Document S/N: 1M1907300131-01-R1.A3L	Test Dates: 08/05/19 - 08/27/19	DUT Type: Portable Tablet		Page 70 of 126

Justification for test configurations for WLAN per KDB Publication 248227 D01v02r02:

- Power measurements were performed for the transmission mode configuration with the highest maximum output power specified for production units.
- For transmission modes with the same maximum output power specification, powers were measured for the largest channel bandwidth, lowest order modulation and lowest data rate.
- For transmission modes with identical maximum specified output power, channel bandwidth, modulation and data rates, power measurements were required for all identical configurations.
- For each transmission mode configuration, powers were measured for the highest and lowest channels; and at the mid-band channel(s) when there were at least 3 channels supported. For configurations with multiple mid-band channels, due to an even number of channels, both channels were measured.

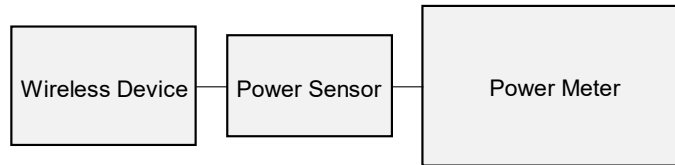



Figure 8-3
Power Measurement Setup

FCC ID: A3LSMT867U	 PCTEST ENGINEERING LABORATORY, INC.	SAR EVALUATION REPORT	 SAMSUNG	Approved by: Quality Manager
Document S/N: 1M1907300131-01-R1.A3L	Test Dates: 08/05/19 - 08/27/19	DUT Type: Portable Tablet	Page 71 of 126	

8.5 Bluetooth Conducted Powers

Table 8-104
Bluetooth Average RF Power

Frequency [MHz]	Data Rate [Mbps]	Channel No.	Avg Conducted Power	
			[dBm]	[mW]
2402	1.0	0	12.82	19.157
2441	1.0	39	12.98	19.844
2480	1.0	78	12.48	17.683
2402	2.0	0	10.73	11.837
2441	2.0	39	10.37	10.883
2480	2.0	78	10.08	10.195
2402	3.0	0	10.78	11.979
2441	3.0	39	10.42	11.019
2480	3.0	78	10.14	10.326



FCC ID: A3LSMT867U		SAR EVALUATION REPORT		Approved by: Quality Manager
Document S/N: 1M1907300131-01-R1.A3L	Test Dates: 08/05/19 - 08/27/19	DUT Type: Portable Tablet	Page 72 of 126	

Figure 8-4
Bluetooth Transmission Plot



Equation 8-1
Bluetooth Duty Cycle Calculation

$$Duty\ Cycle = \frac{Pulse\ Width}{Period} * 100\% = \frac{2.90\ ms}{3.75\ ms} * 100\% = 77.3\%$$

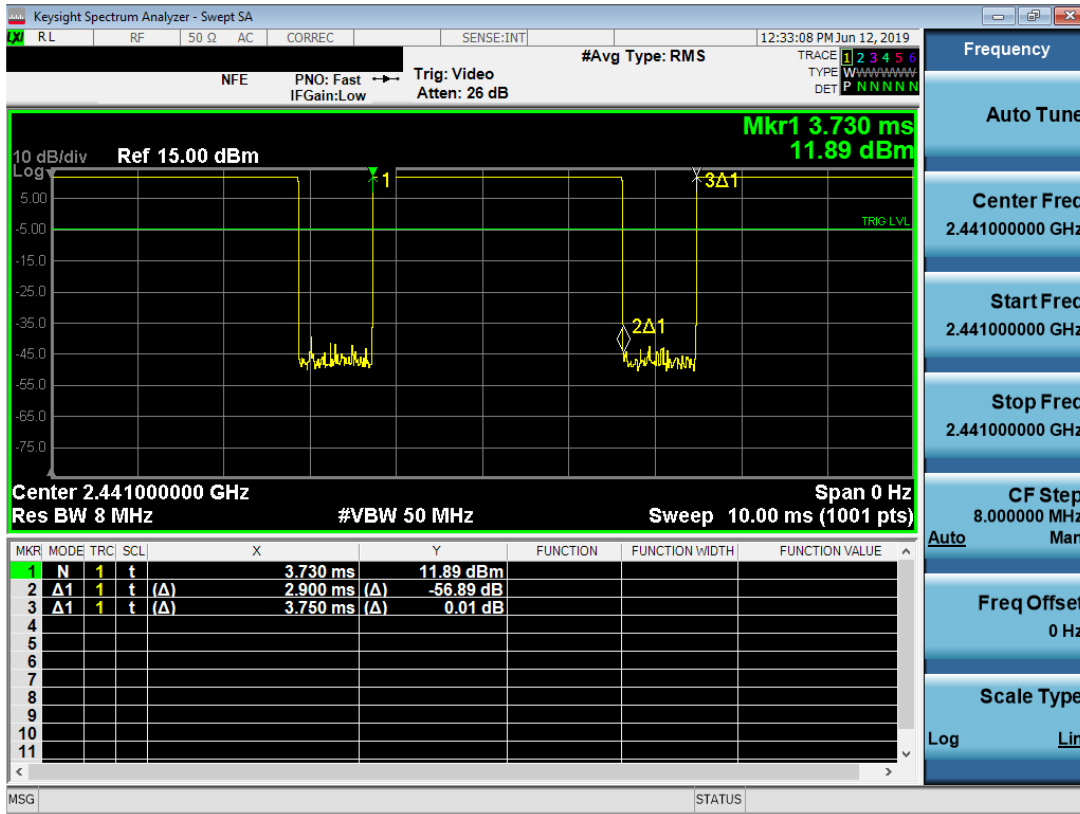
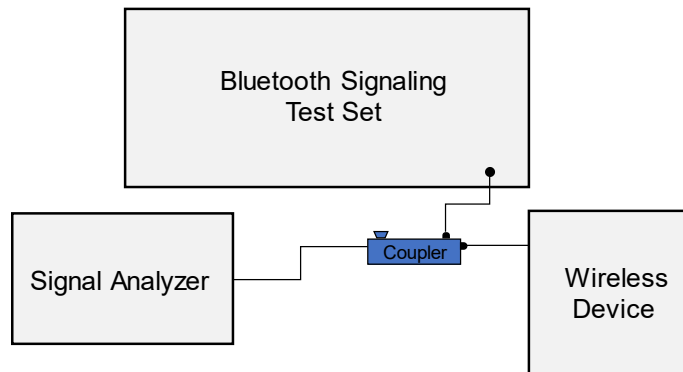

Figure 8-5
Power Measurement Setup

FCC ID: A3LSMT867U		SAR EVALUATION REPORT		Approved by: Quality Manager
Document S/N: 1M1907300131-01-R1.A3L	Test Dates: 08/05/19 - 08/27/19	DUT Type: Portable Tablet		Page 73 of 126



9 SYSTEM VERIFICATION

9.1 Tissue Verification

**Table 9-1
Measured Tissue Properties**

Calibrated for Tests Performed on:	Tissue Type	Tissue Temp During Calibration (°C)	Measured Frequency (MHz)	Measured Conductivity, σ (S/m)	Measured Dielectric Constant, ϵ	TARGET Conductivity, σ (S/m)	TARGET Dielectric Constant, ϵ	% dev σ	% dev ϵ
8/12/2019	750B	21.1	680	0.925	54.070	0.958	55.804	-3.44%	-3.11%
			695	0.930	54.025	0.959	55.745	-3.02%	-3.09%
			700	0.932	54.012	0.959	55.726	-2.82%	-3.08%
			710	0.936	53.991	0.960	55.687	-2.50%	-3.05%
			740	0.948	53.930	0.963	55.570	-1.56%	-2.95%
			755	0.953	53.894	0.964	55.512	-1.14%	-2.91%
			770	0.959	53.853	0.965	55.453	-0.62%	-2.89%
			785	0.964	53.810	0.966	55.395	-0.21%	-2.86%
8/5/2019	835B	19.7	820	0.975	54.495	0.969	55.258	0.62%	-1.38%
			835	0.983	54.443	0.970	55.200	1.34%	-1.37%
			850	0.988	54.418	0.988	55.154	0.00%	-1.33%
8/12/2019	835B	20.8	820	0.957	53.604	0.969	55.258	-1.24%	-2.99%
			835	0.972	53.443	0.970	55.200	0.21%	-3.18%
			850	0.987	53.291	0.988	55.154	-0.10%	-3.38%
8/7/2019	1750B	21.1	1710	1.457	53.108	1.463	53.537	-0.41%	-0.80%
			1750	1.486	53.046	1.488	53.432	-0.13%	-0.72%
			1790	1.515	52.973	1.514	53.326	0.07%	-0.66%
8/13/2019	1750B	24.5	1710	1.411	55.181	1.463	53.537	-3.55%	3.07%
			1750	1.438	55.123	1.488	53.432	-3.36%	3.16%
			1790	1.461	55.060	1.514	53.326	-3.50%	3.25%
8/7/2019	1900B	24.0	1850	1.478	51.602	1.520	53.300	-2.76%	-3.19%
			1880	1.511	51.510	1.520	53.300	-0.59%	-3.36%
			1910	1.545	51.419	1.520	53.300	1.64%	-3.53%
8/27/2019	1900B	20.6	1850	1.520	51.290	1.520	53.300	0.00%	-3.77%
			1880	1.543	51.278	1.520	53.300	1.51%	-3.79%
			1910	1.567	51.191	1.520	53.300	3.09%	-3.96%
8/7/2019	2450B	23.9	2400	1.874	52.648	1.902	52.767	-1.47%	-0.23%
			2450	1.940	52.495	1.950	52.700	-0.51%	-0.39%
			2500	2.009	52.340	2.021	52.636	-0.59%	-0.56%
8/12/2019	2450B-2600B	23.2	2450	2.046	51.692	1.950	52.700	4.92%	-1.91%
			2500	2.112	51.549	2.021	52.636	4.50%	-2.07%
			2550	2.168	51.397	2.092	52.573	3.63%	-2.24%
			2600	2.235	51.220	2.163	52.509	3.33%	-2.45%
			2400	1.983	51.714	1.902	52.767	4.26%	-2.00%
8/19/2019	2450B-2600B	21.6	2450	2.040	51.560	1.950	52.700	4.62%	-2.16%
			2500	2.101	51.408	2.021	52.636	3.96%	-2.33%
			2550	2.163	51.264	2.092	52.573	3.39%	-2.49%
			2600	2.225	51.087	2.163	52.509	2.87%	-2.71%
			2650	2.285	50.928	2.234	52.445	2.28%	-2.89%
			2700	2.348	50.746	2.305	52.382	1.87%	-3.12%
			5240	5.180	47.097	5.346	48.960	-3.11%	-3.81%
			5260	5.210	47.075	5.369	48.933	-2.96%	-3.80%
08/05/2019	5200B-5800B	22.1	5280	5.235	47.046	5.393	48.906	-2.93%	-3.80%
			5300	5.259	47.008	5.416	48.879	-2.90%	-3.83%
			5500	5.526	46.684	5.650	48.607	-2.19%	-3.96%
			5520	5.556	46.643	5.673	48.580	-2.06%	-3.99%
			5540	5.593	46.598	5.696	48.553	-1.81%	-4.03%
			5600	5.671	46.518	5.766	48.471	-1.65%	-4.03%
			5620	5.698	46.452	5.790	48.444	-1.59%	-4.11%
			5680	5.794	46.361	5.860	48.363	-1.13%	-4.14%
			5700	5.821	46.355	5.883	48.336	-1.05%	-4.10%
			5745	5.880	46.252	5.936	48.275	-0.94%	-4.19%
			5765	5.913	46.212	5.959	48.248	-0.77%	-4.22%
			5785	5.947	46.188	5.982	48.220	-0.59%	-4.21%

The above measured tissue parameters were used in the DASY software. The DASY software was used to perform interpolation to determine the dielectric parameters at the SAR test device frequencies (per KDB Publication 865664 D01v01r04 and IEEE 1528-2013 6.6.1.2). The tissue parameters listed in the SAR test plots may slightly differ from the table above due to significant digit rounding in the software.

FCC ID: A3LSMT867U		SAR EVALUATION REPORT		Approved by: Quality Manager
Document S/N: 1M1907300131-01-R1.A3L	Test Dates: 08/05/19 - 08/27/19	DUT Type: Portable Tablet	Page 74 of 126	

9.2 Test System Verification

Prior to SAR assessment, the system is verified to $\pm 10\%$ of the SAR measurement on the reference dipole at the time of calibration by the calibration facility. Full system validation status and result summary can be found in Appendix E.

**Table 9-2
System Verification Results**

System Verification TARGET & MEASURED												
SAR System #	Tissue Frequency (MHz)	Tissue Type	Date	Amb. Temp (°C)	Liquid Temp (°C)	Input Power (W)	Source SN	Probe SN	Measured SAR _{1g} (W/kg)	1 W Target SAR _{1g} (W/kg)	1 W Normalized SAR _{1g} (W/kg)	Deviation _{1g} (%)
G	750	BODY	08/12/2019	22.0	21.1	0.200	1003	7409	1.800	8.580	9.000	4.90%
O	835	BODY	08/05/2019	20.5	19.7	0.200	4d047	7538	2.030	9.470	10.150	7.18%
O	835	BODY	08/12/2019	20.5	19.8	0.200	4d047	7538	2.060	9.470	10.300	8.76%
G	1750	BODY	08/07/2019	22.0	21.1	0.100	1148	7409	3.990	37.700	39.900	5.84%
H	1750	BODY	08/13/2019	23.2	22.5	0.100	1008	7406	3.690	37.400	36.900	-1.34%
J	1900	BODY	08/07/2019	20.3	22.2	0.100	5d080	7488	4.040	39.200	40.400	3.06%
G	1900	BODY	08/27/2019	24.8	20.6	0.100	5d148	7409	3.890	39.100	38.900	-0.51%
I	2450	BODY	08/07/2019	24.9	23.8	0.100	719	7357	5.400	50.100	54.000	7.78%
K	2450	BODY	08/12/2019	22.9	22.0	0.100	797	7417	4.970	51.100	49.700	-2.74%
K	2600	BODY	08/12/2019	22.9	22.0	0.100	1004	7417	5.310	54.800	53.100	-3.10%
K	2450	BODY	08/19/2019	21.6	21.0	0.100	797	7417	5.050	51.100	50.500	-1.17%
K	2600	BODY	08/19/2019	21.6	21.0	0.100	1004	7417	5.490	54.800	54.900	0.18%
L	5250	BODY	08/05/2019	20.3	21.1	0.050	1057	7410	3.480	75.900	69.600	-8.30%
L	5600	BODY	08/05/2019	20.3	21.1	0.050	1057	7410	3.810	79.900	76.200	-4.63%
L	5750	BODY	08/05/2019	20.3	21.1	0.050	1057	7410	3.560	76.700	71.200	-7.17%

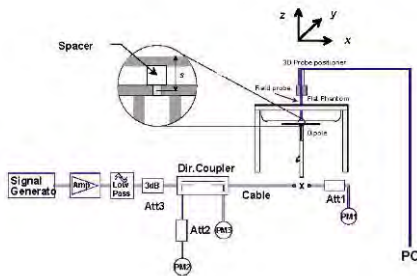

**Figure 9-1
System Verification Setup Diagram**



**Figure 9-2
System Verification Setup Photo**

FCC ID: A3LSMT867U	PCTEST ENGINEERING LABORATORY, INC.	SAR EVALUATION REPORT	SAMSUNG	Approved by: Quality Manager
Document S/N: 1M1907300131-01-R1.A3L	Test Dates: 08/05/19 - 08/27/19	DUT Type: Portable Tablet	Page 75 of 126	

10 SAR DATA SUMMARY

10.1 Standalone Body SAR Data



**Table 10-1
UMTS 850 Body SAR Data**

MEASUREMENT RESULTS																
FREQUENCY		Mode	Service	Maximum Allowed Power [dBm]	Conducted Power [dBm]	Power Drift [dB]	Ant State	Position	Spacing	Device Serial Number	Duty Cycle	Side	SAR (1g)	Scaling Factor	Reported SAR (1g)	Plot #
MHz	Ch.												(W/kg)		(W/kg)	
836.60	4183	UMTS 850	RMC	24.5	24.14	-0.02	54	Body	16 mm	09911	1:1	back	0.530	1.086	0.576	
836.60	4183	UMTS 850	RMC	24.5	24.14	-0.06	54	Body	21 mm	09911	1:1	top	0.496	1.086	0.539	
836.60	4183	UMTS 850	RMC	24.5	24.14	-0.04	54	Body	0 mm	09911	1:1	right	0.223	1.086	0.242	
836.60	4183	UMTS 850	RMC	24.5	24.14	0.03	54	Body	0 mm	09911	1:1	left	0.122	1.086	0.132	
826.40	4132	UMTS 850	RMC	18.0	17.58	0.00	54	Body	0 mm	09911	1:1	back	1.010	1.102	1.113	A1
836.60	4183	UMTS 850	RMC	18.0	17.69	-0.03	54	Body	0 mm	09911	1:1	back	0.990	1.074	1.063	
846.60	4233	UMTS 850	RMC	18.0	17.80	-0.01	54	Body	0 mm	09911	1:1	back	0.965	1.047	1.010	
826.40	4132	UMTS 850	RMC	18.0	17.58	-0.06	54	Body	0 mm	09911	1:1	top	0.958	1.102	1.056	
836.60	4183	UMTS 850	RMC	18.0	17.69	-0.04	54	Body	0 mm	09911	1:1	top	0.907	1.074	0.974	
846.60	4233	UMTS 850	RMC	18.0	17.80	-0.04	54	Body	0 mm	09911	1:1	top	0.915	1.047	0.958	
826.40	4132	UMTS 850	RMC	18.0	17.58	-0.03	54	Body	0 mm	09911	1:1	back	0.997	1.102	1.099	
ANSI / IEEE C95.1 1992 - SAFETY LIMIT Spatial Peak Uncontrolled Exposure/General Population										Body 1.6 W/kg (mW/g) averaged over 1 gram						

Note: Blue entry represents variability measurement.

**Table 10-2
UMTS 1750 Body SAR Data**

MEASUREMENT RESULTS																
FREQUENCY		Mode	Service	Maximum Allowed Power [dBm]	Conducted Power [dBm]	Power Drift [dB]	Ant State	Position	Spacing	Device Serial Number	Duty Cycle	Side	SAR (1g)	Scaling Factor	Reported SAR (1g)	Plot #
MHz	Ch.												(W/kg)		(W/kg)	
1712.40	1312	UMTS 1750	RMC	25.0	24.74	-0.01	26	Body	16 mm	11354	1:1	back	0.758	1.062	0.805	
1732.40	1412	UMTS 1750	RMC	25.0	24.91	0.00	26	Body	16 mm	11354	1:1	back	0.873	1.021	0.891	
1752.60	1513	UMTS 1750	RMC	25.0	24.77	-0.02	26	Body	16 mm	11354	1:1	back	0.923	1.054	0.973	
1732.40	1412	UMTS 1750	RMC	25.0	24.91	-0.01	26	Body	21 mm	11354	1:1	top	0.736	1.021	0.751	
1732.40	1412	UMTS 1750	RMC	25.0	24.91	-0.05	26	Body	0 mm	11354	1:1	right	0.163	1.021	0.166	
1732.40	1412	UMTS 1750	RMC	25.0	24.91	-0.03	26	Body	0 mm	11354	1:1	left	0.204	1.021	0.208	
1712.40	1312	UMTS 1750	RMC	14.0	13.77	-0.03	26	Body	0 mm	11354	1:1	back	0.901	1.054	0.950	
1732.40	1412	UMTS 1750	RMC	14.0	13.96	-0.04	26	Body	0 mm	11354	1:1	back	0.965	1.009	0.974	
1752.60	1513	UMTS 1750	RMC	14.0	13.73	-0.03	26	Body	0 mm	11354	1:1	back	0.986	1.064	1.049	A2
1732.40	1412	UMTS 1750	RMC	14.0	13.96	-0.03	26	Body	0 mm	11354	1:1	top	0.639	1.009	0.645	
ANSI / IEEE C95.1 1992 - SAFETY LIMIT Spatial Peak Uncontrolled Exposure/General Population										Body 1.6 W/kg (mW/g) averaged over 1 gram						



FCC ID: A3LSMT867U		SAR EVALUATION REPORT		Approved by: Quality Manager
Document S/N: 1M1907300131-01-R1.A3L	Test Dates: 08/05/19 - 08/27/19	DUT Type: Portable Tablet	Page 76 of 126	

**Table 10-3
UMTS 1900 Body SAR Data**

MEASUREMENT RESULTS																
FREQUENCY		Mode	Service	Maximum Allowed Power [dBm]	Conducted Power [dBm]	Power Drift [dB]	Ant State	Position	Spacing	Device Serial Number	Duty Cycle	Side	SAR (1g)	Scaling Factor	Reported SAR (1g)	Plot #
MHz	Ch.												(W/kg)		(W/kg)	
1852.40	9262	UMTS 1900	RMC	24.0	23.45	0.03	2	Body	16 mm	10091	1:1	back	0.653	1.135	0.741	
1880.00	9400	UMTS 1900	RMC	24.0	23.58	0.03	2	Body	16 mm	10091	1:1	back	0.737	1.102	0.812	
1907.60	9538	UMTS 1900	RMC	24.0	23.59	0.00	2	Body	16 mm	10091	1:1	back	0.720	1.099	0.791	
1880.00	9400	UMTS 1900	RMC	24.0	23.58	-0.04	2	Body	21 mm	10091	1:1	top	0.687	1.102	0.757	
1880.00	9400	UMTS 1900	RMC	24.0	23.58	-0.04	2	Body	0 mm	10091	1:1	right	0.192	1.102	0.212	
1880.00	9400	UMTS 1900	RMC	24.0	23.58	-0.03	2	Body	0 mm	10091	1:1	left	0.093	1.102	0.102	
1852.40	9262	UMTS 1900	RMC	14.5	13.97	0.02	2	Body	0 mm	10091	1:1	back	0.757	1.130	0.855	
1880.00	9400	UMTS 1900	RMC	14.5	13.94	-0.03	2	Body	0 mm	10091	1:1	back	0.813	1.138	0.925	
1907.60	9538	UMTS 1900	RMC	14.5	14.00	0.00	2	Body	0 mm	10091	1:1	back	0.816	1.122	0.916	A3
1880.00	9400	UMTS 1900	RMC	14.5	13.94	-0.03	2	Body	0 mm	10091	1:1	top	0.483	1.138	0.550	
ANSI / IEEE C95.1 1992 - SAFETY LIMIT Spatial Peak Uncontrolled Exposure/General Population										Body 1.6 W/kg (mW/g) averaged over 1 gram						

**Table 10-4
LTE Band 71 Body SAR**

MEASUREMENT RESULTS																			
FREQUENCY		Mode	Bandwidth [MHz]	Maximum Allowed Power [dBm]	Conducted Power [dBm]	Ant State	Power Drift [dB]	MPR [dB]	Device Serial Number	Modulation	RB Size	RB Offset	Spacing	Side	Duty Cycle	SAR (1g)	Scaling Factor	Reported SAR (1g)	Plot #
MHz	Ch.															(W/kg)		(W/kg)	
680.50	133297	Md	LTE Band 71	20	25.14	51	0.01	0	11388	QPSK	1	0	16 mm	back	1:1	0.252	1.086	0.274	
680.50	133297	Md	LTE Band 71	20	24.21	51	0.00	1	11388	QPSK	50	25	16 mm	back	1:1	0.216	1.069	0.231	
680.50	133297	Md	LTE Band 71	20	25.5	51	-0.08	0	11388	QPSK	1	0	21 mm	top	1:1	0.164	1.086	0.178	
680.50	133297	Md	LTE Band 71	20	24.5	51	-0.02	1	11388	QPSK	50	25	21 mm	top	1:1	0.138	1.069	0.148	
680.50	133297	Md	LTE Band 71	20	25.5	51	0.02	0	11388	QPSK	1	0	0 mm	right	1:1	0.111	1.086	0.121	
680.50	133297	Md	LTE Band 71	20	24.5	51	-0.03	1	11388	QPSK	50	25	0 mm	right	1:1	0.093	1.069	0.099	
680.50	133297	Md	LTE Band 71	20	25.5	51	-0.02	0	11388	QPSK	1	0	0 mm	left	1:1	0.112	1.086	0.122	
680.50	133297	Md	LTE Band 71	20	24.5	51	-0.14	1	11388	QPSK	50	25	0 mm	left	1:1	0.084	1.069	0.090	
680.50	133297	Md	LTE Band 71	20	18.0	51	0.00	0	11388	QPSK	1	0	0 mm	back	1:1	0.446	1.191	0.531	
680.50	133297	Md	LTE Band 71	20	18.0	51	-0.02	0	11388	QPSK	50	0	0 mm	back	1:1	0.451	1.172	0.529	
680.50	133297	Md	LTE Band 71	20	18.0	51	-0.18	0	11388	QPSK	1	0	0 mm	top	1:1	0.553	1.191	0.659	
680.50	133297	Md	LTE Band 71	20	18.0	51	-0.16	0	11388	QPSK	50	0	0 mm	top	1:1	0.591	1.172	0.693	A4
ANSI / IEEE C95.1 1992 - SAFETY LIMIT Spatial Peak Uncontrolled Exposure/General Population										Body 1.6 W/kg (mW/g) averaged over 1 gram									

FCC ID: A3LSMT867U		SAR EVALUATION REPORT		Approved by: Quality Manager
Document S/N: 1M1907300131-01-R1.A3L	Test Dates: 08/05/19 - 08/27/19	DUT Type: Portable Tablet	Page 77 of 126	



**Table 10-5
LTE Band 12 Body SAR**

MEASUREMENT RESULTS																				
FREQUENCY		Mode	Bandwidth [MHz]	Maximum Allowed Power [dBm]	Conducted Power [dBm]	Ant State	Power Drift [dB]	MPR [dB]	Device Serial Number	Modulation	RB Size	RB Offset	Spacing	Side	Duty Cycle	SAR (1g)	Scaling Factor	Reported SAR (1g)	Plot #	
MHz	Ch.															(W/kg)		(W/kg)		
707.50	23095	Md	LTE Band 12	10	25.5	24.80	50	0.01	0	11388	QPSK	1	0	16 mm	back	1:1	0.277	1.175	0.325	
707.50	23095	Md	LTE Band 12	10	24.5	23.87	50	-0.02	1	11388	QPSK	25	0	16 mm	back	1:1	0.242	1.156	0.280	
707.50	23095	Md	LTE Band 12	10	25.5	24.80	50	-0.12	0	11388	QPSK	1	0	21 mm	top	1:1	0.243	1.175	0.286	
707.50	23095	Md	LTE Band 12	10	24.5	23.87	50	-0.19	1	11388	QPSK	25	0	21 mm	top	1:1	0.201	1.156	0.232	
707.50	23095	Md	LTE Band 12	10	25.5	24.80	50	0.01	0	11388	QPSK	1	0	0 mm	right	1:1	0.129	1.175	0.152	
707.50	23095	Md	LTE Band 12	10	24.5	23.87	50	-0.06	1	11388	QPSK	25	0	0 mm	right	1:1	0.107	1.156	0.124	
707.50	23095	Md	LTE Band 12	10	25.5	24.80	50	0.03	0	11388	QPSK	1	0	0 mm	left	1:1	0.138	1.175	0.162	
707.50	23095	Md	LTE Band 12	10	24.5	23.87	50	-0.07	1	11388	QPSK	25	0	0 mm	left	1:1	0.096	1.156	0.111	
707.50	23095	Md	LTE Band 12	10	18.0	17.39	50	-0.09	0	11388	QPSK	1	0	0 mm	back	1:1	0.587	1.151	0.676	
707.50	23095	Md	LTE Band 12	10	18.0	17.46	50	-0.02	0	11388	QPSK	25	0	0 mm	back	1:1	0.618	1.132	0.700	
707.50	23095	Md	LTE Band 12	10	18.0	17.39	50	-0.03	0	11388	QPSK	1	0	0 mm	top	1:1	0.714	1.151	0.822	
707.50	23095	Md	LTE Band 12	10	18.0	17.46	50	-0.03	0	11388	QPSK	25	0	0 mm	top	1:1	0.754	1.132	0.854	
707.50	23095	Md	LTE Band 12	10	18.0	17.38	50	-0.06	0	11388	QPSK	50	0	0 mm	top	1:1	0.754	1.153	0.869	A5
ANSI / IEEE C95.1 1992 - SAFETY LIMIT Spatial Peak Uncontrolled Exposure/General Population										Body 1.6 W/kg (mW/g) averaged over 1 gram										

**Table 10-6
LTE Band 13 Body SAR**



MEASUREMENT RESULTS																				
FREQUENCY		Mode	Bandwidth [MHz]	Maximum Allowed Power [dBm]	Conducted Power [dBm]	Ant State	Power Drift [dB]	MPR [dB]	Device Serial Number	Modulation	RB Size	RB Offset	Spacing	Side	Duty Cycle	SAR (1g)	Scaling Factor	Reported SAR (1g)	Plot #	
MHz	Ch.															(W/kg)		(W/kg)		
782.00	23230	Md	LTE Band 13	10	25.0	24.33	52	-0.12	0	11388	QPSK	1	49	16 mm	back	1:1	0.401	1.167	0.468	
782.00	23230	Md	LTE Band 13	10	24.0	23.50	52	0.00	1	11388	QPSK	25	25	16 mm	back	1:1	0.331	1.122	0.371	
782.00	23230	Md	LTE Band 13	10	25.0	24.33	52	-0.03	0	11388	QPSK	1	49	21 mm	top	1:1	0.276	1.167	0.322	
782.00	23230	Md	LTE Band 13	10	24.0	23.50	52	-0.01	1	11388	QPSK	25	25	21 mm	top	1:1	0.235	1.122	0.264	
782.00	23230	Md	LTE Band 13	10	25.0	24.33	52	0.07	0	11388	QPSK	1	49	0 mm	right	1:1	0.200	1.167	0.233	
782.00	23230	Md	LTE Band 13	10	24.0	23.50	52	-0.01	1	11388	QPSK	25	25	0 mm	right	1:1	0.163	1.122	0.183	
782.00	23230	Md	LTE Band 13	10	25.0	24.33	52	-0.05	0	11388	QPSK	1	49	0 mm	left	1:1	0.122	1.167	0.142	
782.00	23230	Md	LTE Band 13	10	24.0	23.50	52	-0.09	1	11388	QPSK	25	25	0 mm	left	1:1	0.103	1.122	0.116	
782.00	23230	Md	LTE Band 13	10	19.0	18.50	52	-0.10	0	11388	QPSK	1	49	0 mm	back	1:1	1.000	1.122	1.122	
782.00	23230	Md	LTE Band 13	10	19.0	18.58	52	-0.05	0	11388	QPSK	25	25	0 mm	back	1:1	1.040	1.102	1.146	
782.00	23230	Md	LTE Band 13	10	19.0	18.48	52	0.00	0	11388	QPSK	50	0	0 mm	back	1:1	1.070	1.127	1.206	A6
782.00	23230	Md	LTE Band 13	10	19.0	18.50	52	-0.16	0	11388	QPSK	1	49	0 mm	top	1:1	0.993	1.122	1.114	
782.00	23230	Md	LTE Band 13	10	19.0	18.58	52	-0.10	0	11388	QPSK	25	25	0 mm	top	1:1	1.030	1.102	1.135	
782.00	23230	Md	LTE Band 13	10	19.0	18.48	52	-0.06	0	11388	QPSK	50	0	0 mm	top	1:1	1.040	1.127	1.172	
782.00	23230	Md	LTE Band 13	10	19.0	18.48	52	-0.04	0	11388	QPSK	50	0	0 mm	back	1:1	1.020	1.127	1.150	
ANSI / IEEE C95.1 1992 - SAFETY LIMIT Spatial Peak Uncontrolled Exposure/General Population										Body 1.6 W/kg (mW/g) averaged over 1 gram										

Note: Blue entry represents variability measurement.

FCC ID: A3LSMT867U		SAR EVALUATION REPORT		Approved by: Quality Manager
Document S/N: 1M1907300131-01-R1.A3L	Test Dates: 08/05/19 - 08/27/19	DUT Type: Portable Tablet	Page 78 of 126	

**Table 10-7
LTE Band 26 (Cell) Body SAR**



MEASUREMENT RESULTS																				
FREQUENCY		Mode	Bandwidth [MHz]	Maximum Allowed Power [dBm]	Conducted Power [dBm]	Ant State	Power Drift [dB]	MPR [dB]	Device Serial Number	Modulation	RB Size	RB Offset	Spacing	Side	Duty Cycle	SAR (1g)	Scaling Factor	Reported SAR (1g)	Plot #	
MHz	Ch.															(W/kg)		(W/kg)		
831.50	26865	Mid	LTE Band 26 (Cell)	15	25.0	24.44	52	-0.01	0	09911	QPSK	1	0	16 mm	back	1:1	0.638	1.138	0.726	
831.50	26865	Mid	LTE Band 26 (Cell)	15	24.0	23.43	52	0.01	1	09911	QPSK	36	37	16 mm	back	1:1	0.503	1.140	0.573	
831.50	26865	Mid	LTE Band 26 (Cell)	15	25.0	24.44	52	-0.01	0	09911	QPSK	1	0	21 mm	top	1:1	0.593	1.138	0.675	
831.50	26865	Mid	LTE Band 26 (Cell)	15	24.0	23.43	52	-0.01	1	09911	QPSK	36	37	21 mm	top	1:1	0.451	1.140	0.514	
831.50	26865	Mid	LTE Band 26 (Cell)	15	25.0	24.44	52	-0.07	0	09911	QPSK	1	0	0 mm	right	1:1	0.265	1.138	0.302	
831.50	26865	Mid	LTE Band 26 (Cell)	15	24.0	23.43	52	0.03	1	09911	QPSK	36	37	0 mm	right	1:1	0.204	1.140	0.233	
831.50	26865	Mid	LTE Band 26 (Cell)	15	25.0	24.44	52	0.02	0	09911	QPSK	1	0	0 mm	left	1:1	0.111	1.138	0.126	
831.50	26865	Mid	LTE Band 26 (Cell)	15	24.0	23.43	52	0.08	1	09911	QPSK	36	37	0 mm	left	1:1	0.092	1.140	0.105	
831.50	26865	Mid	LTE Band 26 (Cell)	15	18.0	17.44	52	-0.03	0	09911	QPSK	1	0	0 mm	back	1:1	0.908	1.138	1.033	
831.50	26865	Mid	LTE Band 26 (Cell)	15	18.0	17.45	52	-0.01	0	09911	QPSK	36	0	0 mm	back	1:1	0.899	1.135	1.020	
831.50	26865	Mid	LTE Band 26 (Cell)	15	18.0	17.41	52	-0.02	0	09911	QPSK	75	0	0 mm	back	1:1	0.869	1.146	0.996	
831.50	26865	Mid	LTE Band 26 (Cell)	15	18.0	17.44	52	-0.05	0	09911	QPSK	1	0	0 mm	top	1:1	0.910	1.138	1.036	A7
831.50	26865	Mid	LTE Band 26 (Cell)	15	18.0	17.45	52	-0.06	0	09911	QPSK	36	0	0 mm	top	1:1	0.853	1.135	0.968	
831.50	26865	Mid	LTE Band 26 (Cell)	15	18.0	17.41	52	-0.04	0	09911	QPSK	75	0	0 mm	top	1:1	0.853	1.146	0.978	
ANSI / IEEE C95.1 1992 - SAFETY LIMIT Spatial Peak Uncontrolled Exposure/General Population									Body 1.6 W/kg (mW/g) averaged over 1 gram											

FCC ID: A3LSMT867U		SAR EVALUATION REPORT		Approved by: Quality Manager
Document S/N: 1M1907300131-01-R1.A3L	Test Dates: 08/05/19 - 08/27/19	DUT Type: Portable Tablet	Page 79 of 126	

**Table 10-8
LTE Band 66 (AWS) Body SAR**

MEASUREMENT RESULTS																					
1 CC Uplink	Component Carrier	FREQUENCY		Mode	Bandwidth [MHz]	Maximum Allowed Power [dBm]	Conducted Power [dBm]	Ant State	Power Drift [dB]	MPR [dB]	Device Serial Number	Modulation	RB Size	RB Offset	Spacing	Side	Duty Cycle	SAR (1g) [W/kg]	Scaling Factor	Reported SAR (1g) [W/kg]	Plot #
		MHz	Ch.																		
1 CC Uplink	N/A	1720.00	132072	Low	20	25.5	25.04	26	0.03	0	04724	QPSK	1	0	16 mm	back	1:1	0.726	1.112	0.807	
1 CC Uplink	N/A	1745.00	132322	Mid	20	25.5	25.25	26	0.00	0	04724	QPSK	1	50	16 mm	back	1:1	0.882	1.059	0.934	
1 CC Uplink	N/A	1770.00	132572	High	20	25.5	25.09	26	0.04	0	04724	QPSK	1	0	16 mm	back	1:1	0.660	1.099	0.725	
1 CC Uplink	N/A	1745.00	132322	Mid	20	24.5	24.43	26	0.00	1	04724	QPSK	50	0	16 mm	back	1:1	0.718	1.016	0.729	
1 CC Uplink	N/A	1745.00	132322	Mid	20	24.5	24.38	26	-0.03	1	04724	QPSK	100	0	16 mm	back	1:1	0.719	1.028	0.739	
1 CC Uplink	N/A	1720.00	132072	Low	20	25.5	25.04	26	-0.02	0	04724	QPSK	1	0	21 mm	top	1:1	0.777	1.112	0.864	
1 CC Uplink	N/A	1745.00	132322	Mid	20	25.5	25.25	26	-0.04	0	04724	QPSK	1	50	21 mm	top	1:1	0.879	1.059	0.931	
1 CC Uplink	N/A	1770.00	132572	High	20	25.5	25.09	26	0.01	0	04724	QPSK	1	0	21 mm	top	1:1	0.711	1.099	0.781	
1 CC Uplink	N/A	1745.00	132322	Mid	20	24.5	24.43	26	-0.03	1	04724	QPSK	50	0	21 mm	top	1:1	0.663	1.016	0.674	
1 CC Uplink	N/A	1745.00	132322	Mid	20	24.5	24.38	26	-0.03	1	04724	QPSK	100	0	21 mm	top	1:1	0.723	1.028	0.743	
1 CC Uplink	N/A	1745.00	132322	Mid	20	25.5	25.25	26	-0.07	0	04724	QPSK	1	50	0 mm	right	1:1	0.160	1.059	0.169	
1 CC Uplink	N/A	1745.00	132322	Mid	20	24.5	24.43	26	0.02	1	04724	QPSK	50	0	0 mm	right	1:1	0.102	1.016	0.104	
1 CC Uplink	N/A	1745.00	132322	Mid	20	25.5	25.25	26	0.05	0	04724	QPSK	1	50	0 mm	left	1:1	0.260	1.059	0.275	
1 CC Uplink	N/A	1745.00	132322	Mid	20	24.5	24.43	26	0.02	1	04724	QPSK	50	0	0 mm	left	1:1	0.213	1.016	0.216	
1 CC Uplink	N/A	1720.00	132072	Low	20	14.5	14.25	26	-0.03	0	04724	QPSK	1	0	0 mm	back	1:1	0.915	1.059	0.969	
1 CC Uplink	N/A	1745.00	132322	Mid	20	14.5	14.32	26	-0.01	0	04724	QPSK	1	0	0 mm	back	1:1	0.853	1.042	0.889	
1 CC Uplink	N/A	1770.00	132572	High	20	14.5	14.17	26	-0.01	0	04724	QPSK	1	0	0 mm	back	1:1	0.856	1.079	0.924	
1 CC Uplink	N/A	1720.00	132072	Low	20	14.5	14.40	26	-0.01	0	04724	QPSK	50	0	0 mm	back	1:1	1.000	1.023	1.023	A8
1 CC Uplink	N/A	1720.00	132072	Low	20	14.5	14.14	26	-0.01	0	04724	QPSK	50	50	0 mm	back	1:1	0.976	1.086	1.060	
1 CC Uplink	N/A	1715.00	132022	Low	10	14.5	13.98	26	-0.04	0	04724	QPSK	25	25	0 mm	back	1:1	0.940	1.127	1.059	
1 CC Uplink	N/A	1745.00	132322	Mid	20	14.5	14.45	26	-0.02	0	04724	QPSK	50	0	0 mm	back	1:1	0.881	1.012	0.892	
1 CC Uplink	N/A	1770.00	132572	High	20	14.5	14.26	26	-0.01	0	04724	QPSK	50	0	0 mm	back	1:1	0.841	1.057	0.889	
1 CC Uplink	N/A	1745.00	132322	Mid	20	14.5	14.27	26	0.00	0	04724	QPSK	100	0	0 mm	back	1:1	0.856	1.054	0.902	
CA_66C 2 CC Uplink	PCC	1720.00	132072	Low	20	14.5	14.40	26	-0.05	0	04724	QPSK	50	50	0 mm	back	1:1	0.985	1.023	1.008	
	SCC	1739.80	132270	Low									LTE Band 66 (AWS)	50							
CA_66B 2 CC Uplink	PCC	1715.00	132022	Low	10	14.5	14.24	26	-0.06	0	04724	QPSK	25	25	0 mm	back	1:1	0.992	1.062	1.054	
	SCC	1724.90	132121	Low									LTE Band 66 (AWS)	25							
1 CC Uplink	N/A	1745.00	132322	Mid	20	14.5	14.32	26	-0.04	0	04724	QPSK	1	0	0 mm	top	1:1	0.480	1.042	0.500	
1 CC Uplink	N/A	1745.00	132322	Mid	20	14.5	14.45	26	-0.09	0	04724	QPSK	50	0	0 mm	top	1:1	0.497	1.012	0.503	
1 CC Uplink	N/A	1720.00	132072	Low	20	14.5	14.40	26	0.05	0	04724	QPSK	50	0	0 mm	back	1:1	0.997	1.023	1.020	
ANSI / IEEE C95.1 1992 - SAFETY LIMIT Spatial Peak Uncontrolled Exposure/General Population										Body 1.6 W/kg (mW/g) averaged over 1 gram											

Note: Blue entry represents variability measurement.

FCC ID: A3LSMT867U		SAR EVALUATION REPORT		Approved by: Quality Manager
Document S/N: 1M1907300131-01-R1.A3L	Test Dates: 08/05/19 - 08/27/19	DUT Type: Portable Tablet	Page 80 of 126	



**Table 10-9
LTE Band 2 (PCS) Body SAR**

MEASUREMENT RESULTS																				
FREQUENCY		Mode	Bandwidth [MHz]	Maximum Allowed Power [dBm]	Conducted Power [dBm]	Ant State	Power Drift [dB]	MPR [dB]	Device Serial Number	Modulation	RB Size	RB Offset	Spacing	Side	Duty Cycle	SAR (1g)	Scaling Factor	Reported SAR (1g)	Plot #	
MHz	Ch.															(W/kg)		(W/kg)		
1880.00	18900	Mid	LTE Band 2 (PCS)	20	25.0	24.38	24	0.00	0	10091	QPSK	1	99	16 mm	back	1:1	0.640	1.153	0.738	
1900.00	19100	High	LTE Band 2 (PCS)	20	24.0	23.51	24	-0.01	1	10091	QPSK	50	50	16 mm	back	1:1	0.528	1.119	0.591	
1860.00	18700	Low	LTE Band 2 (PCS)	20	25.0	24.32	24	-0.06	0	10091	QPSK	1	99	21 mm	top	1:1	0.691	1.169	0.808	
1880.00	18900	Mid	LTE Band 2 (PCS)	20	25.0	24.38	24	-0.04	0	10091	QPSK	1	99	21 mm	top	1:1	0.739	1.153	0.852	
1900.00	19100	High	LTE Band 2 (PCS)	20	25.0	24.37	24	-0.06	0	10091	QPSK	1	99	21 mm	top	1:1	0.699	1.156	0.808	
1900.00	19100	High	LTE Band 2 (PCS)	20	24.0	23.51	24	-0.11	1	10091	QPSK	50	50	21 mm	top	1:1	0.587	1.119	0.657	
1900.00	19100	High	LTE Band 2 (PCS)	20	24.0	23.49	24	-0.02	1	10091	QPSK	100	0	21 mm	top	1:1	0.540	1.125	0.608	
1880.00	18900	Mid	LTE Band 2 (PCS)	20	25.0	24.38	24	0.11	0	10091	QPSK	1	99	0 mm	right	1:1	0.157	1.153	0.181	
1900.00	19100	High	LTE Band 2 (PCS)	20	24.0	23.51	24	0.04	1	10091	QPSK	50	50	0 mm	right	1:1	0.152	1.119	0.170	
1880.00	18900	Mid	LTE Band 2 (PCS)	20	25.0	24.38	24	-0.05	0	10091	QPSK	1	99	0 mm	left	1:1	0.098	1.153	0.113	
1900.00	19100	High	LTE Band 2 (PCS)	20	24.0	23.51	24	-0.08	1	10091	QPSK	50	50	0 mm	left	1:1	0.090	1.119	0.101	
1860.00	18700	Low	LTE Band 2 (PCS)	20	14.5	13.89	24	-0.01	0	10091	QPSK	1	0	0 mm	back	1:1	0.697	1.151	0.802	
1880.00	18900	Mid	LTE Band 2 (PCS)	20	14.5	14.00	24	-0.03	0	10091	QPSK	1	0	0 mm	back	1:1	0.841	1.122	0.944	
1900.00	19100	High	LTE Band 2 (PCS)	20	14.5	13.97	24	-0.02	0	10091	QPSK	1	0	0 mm	back	1:1	0.784	1.130	0.886	
1860.00	18700	Low	LTE Band 2 (PCS)	20	14.5	13.93	24	-0.02	0	10091	QPSK	50	0	0 mm	back	1:1	0.710	1.140	0.809	
1880.00	18900	Mid	LTE Band 2 (PCS)	20	14.5	14.10	24	-0.03	0	10091	QPSK	50	0	0 mm	back	1:1	0.877	1.096	0.961	A9
1900.00	19100	High	LTE Band 2 (PCS)	20	14.5	14.13	24	-0.02	0	10091	QPSK	50	0	0 mm	back	1:1	0.802	1.089	0.873	
1900.00	19100	High	LTE Band 2 (PCS)	20	14.5	13.96	24	-0.17	0	10091	QPSK	100	0	0 mm	back	1:1	0.795	1.132	0.900	
1880.00	18900	Mid	LTE Band 2 (PCS)	20	14.5	14.00	24	-0.09	0	10091	QPSK	1	0	0 mm	top	1:1	0.442	1.122	0.496	
1900.00	19100	High	LTE Band 2 (PCS)	20	14.5	14.13	24	-0.07	0	10091	QPSK	50	0	0 mm	top	1:1	0.395	1.089	0.430	
ANSI / IEEE C95.1 1992 - SAFETY LIMIT Spatial Peak Uncontrolled Exposure/General Population										Body 1.6 W/kg (mW/g) averaged over 1 gram										

**Table 10-10
LTE Band 25 (PCS) Body SAR**

MEASUREMENT RESULTS																				
FREQUENCY		Mode	Bandwidth [MHz]	Maximum Allowed Power [dBm]	Conducted Power [dBm]	Ant State	Power Drift [dB]	MPR [dB]	Device Serial Number	Modulation	RB Size	RB Offset	Spacing	Side	Duty Cycle	SAR (1g)	Scaling Factor	Reported SAR (1g)	Plot #	
MHz	Ch.															(W/kg)		(W/kg)		
1905.00	26590	High	LTE Band 25 (PCS)	20	24.5	24.16	3	0.00	0	10091	QPSK	1	0	16 mm	back	1:1	0.657	1.081	0.710	
1905.00	26590	High	LTE Band 25 (PCS)	20	23.5	23.14	3	0.01	1	10091	QPSK	50	25	16 mm	back	1:1	0.520	1.086	0.565	
1905.00	26590	High	LTE Band 25 (PCS)	20	24.5	24.16	3	-0.06	0	10091	QPSK	1	0	21 mm	top	1:1	0.648	1.081	0.700	
1905.00	26590	High	LTE Band 25 (PCS)	20	23.5	23.14	3	-0.05	1	10091	QPSK	50	25	21 mm	top	1:1	0.527	1.086	0.572	
1905.00	26590	High	LTE Band 25 (PCS)	20	24.5	24.16	3	0.11	0	10091	QPSK	1	0	0 mm	right	1:1	0.172	1.081	0.186	
1905.00	26590	High	LTE Band 25 (PCS)	20	23.5	23.14	3	0.04	1	10091	QPSK	50	25	0 mm	right	1:1	0.143	1.086	0.155	
1905.00	26590	High	LTE Band 25 (PCS)	20	24.5	24.16	3	-0.09	0	10091	QPSK	1	0	0 mm	left	1:1	0.104	1.081	0.112	
1905.00	26590	High	LTE Band 25 (PCS)	20	23.5	23.14	3	0.09	1	10091	QPSK	50	25	0 mm	left	1:1	0.080	1.086	0.087	
1860.00	26140	Low	LTE Band 25 (PCS)	20	14.5	14.02	3	-0.01	0	10091	QPSK	1	0	0 mm	back	1:1	0.883	1.117	0.986	
1882.50	26365	Mid	LTE Band 25 (PCS)	20	14.5	13.99	3	0.03	0	10091	QPSK	1	99	0 mm	back	1:1	0.911	1.125	1.025	
1905.00	26590	High	LTE Band 25 (PCS)	20	14.5	14.15	3	0.01	0	10091	QPSK	1	0	0 mm	back	1:1	0.937	1.084	1.016	
1860.00	26140	Low	LTE Band 25 (PCS)	20	14.5	14.07	3	0.00	0	10091	QPSK	50	0	0 mm	back	1:1	0.905	1.104	0.999	
1882.50	26365	Mid	LTE Band 25 (PCS)	20	14.5	14.12	3	-0.02	0	10091	QPSK	50	0	0 mm	back	1:1	0.959	1.091	1.046	
1905.00	26590	High	LTE Band 25 (PCS)	20	14.5	14.20	3	0.00	0	10091	QPSK	50	0	0 mm	back	1:1	0.994	1.072	1.066	A10
1905.00	26590	High	LTE Band 25 (PCS)	20	14.5	14.11	3	0.00	0	10091	QPSK	100	0	0 mm	back	1:1	0.956	1.094	1.046	
1905.00	26590	High	LTE Band 25 (PCS)	20	14.5	14.15	3	-0.09	0	10091	QPSK	1	0	0 mm	top	1:1	0.503	1.084	0.545	
1905.00	26590	High	LTE Band 25 (PCS)	20	14.5	14.20	3	0.18	0	10091	QPSK	50	0	0 mm	top	1:1	0.514	1.072	0.551	
1905.00	26590	High	LTE Band 25 (PCS)	20	14.5	14.20	3	-0.05	0	10091	QPSK	50	0	0 mm	back	1:1	0.975	1.072	1.045	
ANSI / IEEE C95.1 1992 - SAFETY LIMIT Spatial Peak Uncontrolled Exposure/General Population										Body 1.6 W/kg (mW/g) averaged over 1 gram										



Note: Blue entry represents variability measurement.

FCC ID: A3LSMT867U		SAR EVALUATION REPORT		Approved by: Quality Manager
Document S/N: 1M1907300131-01-R1.A3L	Test Dates: 08/05/19 - 08/27/19	DUT Type: Portable Tablet		Page 81 of 126

**Table 10-11
LTE Band 7 Body SAR**



MEASUREMENT RESULTS																			
FREQUENCY		Mode	Bandwidth [MHz]	Maximum Allowed Power [dBm]	Conducted Power [dBm]	Power Drift [dB]	MPR [dB]	Device Serial Number	Modulation	RB Size	RB Offset	Spacing	Side	Duty Cycle	SAR (1g)	Scaling Factor	Reported SAR (1g)	Plot #	
MHz	Ch.														(W/kg)		(W/kg)		
2560.00	21350	High	LTE Band 7	20	23.5	23.08	0.10	0	11354	QPSK	1	50	16 mm	back	1:1	0.224	1.102	0.247	
2560.00	21350	High	LTE Band 7	20	22.5	22.22	0.07	1	11354	QPSK	50	0	16 mm	back	1:1	0.191	1.067	0.204	
2560.00	21350	High	LTE Band 7	20	23.5	23.08	-0.05	0	11354	QPSK	1	50	21 mm	top	1:1	0.156	1.102	0.172	
2560.00	21350	High	LTE Band 7	20	22.5	22.22	0.04	1	11354	QPSK	50	0	21 mm	top	1:1	0.131	1.067	0.140	
2560.00	21350	High	LTE Band 7	20	23.5	23.08	-0.03	0	11354	QPSK	1	50	0 mm	right	1:1	0.315	1.102	0.347	
2560.00	21350	High	LTE Band 7	20	22.5	22.22	-0.17	1	11354	QPSK	50	0	0 mm	right	1:1	0.227	1.067	0.242	
2560.00	21350	High	LTE Band 7	20	23.5	23.08	-0.03	0	11354	QPSK	1	50	0 mm	left	1:1	0.323	1.102	0.356	
2560.00	21350	High	LTE Band 7	20	22.5	22.22	-0.01	1	11354	QPSK	50	0	0 mm	left	1:1	0.264	1.067	0.282	
2510.00	20850	Low	LTE Band 7	20	14.5	13.90	0.01	0	11354	QPSK	1	99	0 mm	back	1:1	0.948	1.148	1.088	
2535.00	21100	Mid	LTE Band 7	20	14.5	13.88	-0.01	0	11354	QPSK	1	0	0 mm	back	1:1	0.886	1.153	1.022	
2560.00	21350	High	LTE Band 7	20	14.5	14.21	-0.01	0	11354	QPSK	1	0	0 mm	back	1:1	0.822	1.069	0.879	
2510.00	20850	Low	LTE Band 7	20	14.5	14.00	0.00	0	11354	QPSK	50	0	0 mm	back	1:1	1.010	1.122	1.133	
2535.00	21100	Mid	LTE Band 7	20	14.5	13.97	-0.01	0	11354	QPSK	50	0	0 mm	back	1:1	0.905	1.130	1.023	
2560.00	21350	High	LTE Band 7	20	14.5	14.32	-0.01	0	11354	QPSK	50	25	0 mm	back	1:1	0.802	1.042	0.836	
2560.00	21350	High	LTE Band 7	20	14.5	14.19	-0.01	0	11354	QPSK	100	0	0 mm	back	1:1	0.801	1.074	0.860	
2510.00	20850	Low	LTE Band 7	20	14.5	13.90	-0.10	0	11354	QPSK	1	99	0 mm	top	1:1	0.977	1.148	1.122	
2535.00	21100	Mid	LTE Band 7	20	14.5	13.88	-0.12	0	11354	QPSK	1	0	0 mm	top	1:1	0.938	1.153	1.082	
2560.00	21350	High	LTE Band 7	20	14.5	14.21	-0.10	0	11354	QPSK	1	0	0 mm	top	1:1	0.893	1.069	0.955	
2510.00	20850	Low	LTE Band 7	20	14.5	14.00	-0.11	0	11354	QPSK	50	0	0 mm	top	1:1	1.020	1.122	1.144	A11
2535.00	21100	Mid	LTE Band 7	20	14.5	13.97	-0.13	0	11354	QPSK	50	0	0 mm	top	1:1	0.969	1.130	1.095	
2560.00	21350	High	LTE Band 7	20	14.5	14.32	-0.13	0	11354	QPSK	50	25	0 mm	top	1:1	0.895	1.042	0.933	
2560.00	21350	High	LTE Band 7	20	14.5	14.19	-0.10	0	11354	QPSK	100	0	0 mm	top	1:1	0.900	1.074	0.967	
2510.00	20850	Low	LTE Band 7	20	14.5	14.00	-0.10	0	11354	QPSK	50	0	0 mm	top	1:1	1.020	1.122	1.144	
2535.00	21100	Mid	LTE Band 7	20	14.5	13.97	-0.01	0	11354	QPSK	50	0	0 mm	top	1:1	0.966	1.130	1.092	
ANSI / IEEE C95.1 1992 - SAFETY LIMIT								Body											
Spatial Peak								1.6 W/kg (mW/g)											
Uncontrolled Exposure/General Population								averaged over 1 gram											

Note: Blue entries represent variability measurements.

FCC ID: A3LSMT867U		SAR EVALUATION REPORT		Approved by: Quality Manager
Document S/N: 1M1907300131-01-R1.A3L	Test Dates: 08/05/19 - 08/27/19	DUT Type: Portable Tablet	Page 82 of 126	



**Table 10-12
LTE Band 41 Body SAR**

MEASUREMENT RESULTS																					
1 CC Uplink 2 CC Uplink, Power Class	Component Carrier	FREQUENCY		Mode	Bandwidth [MHz]	Maximum Allowed Power [dBm]	Conducted Power [dBm]	Power Drift [dB]	MPR [dB]	Device Serial Number	Modulation	RB Size	RB Offset	Spacing	Side	Duty Cycle	SAR (1g)	Scaling Factor	Reported SAR	Plot #	
		MHz	Ch.														(W/kg)		(1g) (W/kg)		
1 CC Uplink - Power Class 3	NA	2593.00	40620	Mid	LTE Band 41	20	24.5	24.16	0.09	0	09911	QPSK	1	50	16 mm	back	1:1.58	0.174	1.081	0.188	
1 CC Uplink - Power Class 3	NA	2593.00	40620	Mid	LTE Band 41	20	23.5	23.35	0.03	1	09911	QPSK	50	25	16 mm	back	1:1.58	0.142	1.035	0.147	
1 CC Uplink - Power Class 3	NA	2593.00	40620	Mid	LTE Band 41	20	24.5	24.16	-0.08	0	09911	QPSK	1	50	21 mm	top	1:1.58	0.161	1.081	0.174	
1 CC Uplink - Power Class 3	NA	2593.00	40620	Mid	LTE Band 41	20	23.5	23.35	0.03	1	09911	QPSK	50	25	21 mm	top	1:1.58	0.133	1.035	0.138	
1 CC Uplink - Power Class 3	NA	2593.00	40620	Mid	LTE Band 41	20	24.5	24.16	-0.05	0	09911	QPSK	1	50	0 mm	right	1:1.58	0.248	1.081	0.268	
1 CC Uplink - Power Class 3	NA	2593.00	40620	Mid	LTE Band 41	20	23.5	23.35	0.09	1	09911	QPSK	50	25	0 mm	right	1:1.58	0.198	1.035	0.205	
1 CC Uplink - Power Class 3	NA	2593.00	40620	Mid	LTE Band 41	20	24.5	24.16	0.05	0	09911	QPSK	1	50	0 mm	left	1:1.58	0.439	1.081	0.475	
1 CC Uplink - Power Class 3	NA	2593.00	40620	Mid	LTE Band 41	20	23.5	23.35	0.03	1	09911	QPSK	50	25	0 mm	left	1:1.58	0.372	1.035	0.385	
1 CC Uplink - Power Class 3	NA	2506.00	39750	Low	LTE Band 41	20	14.0	13.35	0.01	0	09911	QPSK	1	0	0 mm	back	1:1.58	0.489	1.161	0.568	
1 CC Uplink - Power Class 3	NA	2549.50	40185	Low-Md	LTE Band 41	20	14.0	13.43	0.01	0	09911	QPSK	1	0	0 mm	back	1:1.58	0.517	1.140	0.589	
1 CC Uplink - Power Class 3	NA	2593.00	40620	Mid	LTE Band 41	20	14.0	13.72	0.04	0	09911	QPSK	1	0	0 mm	back	1:1.58	0.653	1.067	0.697	
1 CC Uplink - Power Class 3	NA	2636.50	41055	Mid-High	LTE Band 41	20	14.0	13.43	0.01	0	09911	QPSK	1	0	0 mm	back	1:1.58	0.569	1.140	0.649	
1 CC Uplink - Power Class 3	NA	2680.00	41490	High	LTE Band 41	20	14.0	13.25	0.00	0	09911	QPSK	1	0	0 mm	back	1:1.58	0.579	1.189	0.688	
1 CC Uplink - Power Class 3	NA	2506.00	39750	Low	LTE Band 41	20	14.0	13.38	0.03	0	09911	QPSK	50	25	0 mm	back	1:1.58	0.491	1.153	0.566	
1 CC Uplink - Power Class 3	NA	2549.50	40185	Low-Md	LTE Band 41	20	14.0	13.57	0.01	0	09911	QPSK	50	50	0 mm	back	1:1.58	0.537	1.104	0.593	
1 CC Uplink - Power Class 3	NA	2593.00	40620	Mid	LTE Band 41	20	14.0	13.75	-0.01	0	09911	QPSK	50	0	0 mm	back	1:1.58	0.632	1.059	0.669	
1 CC Uplink - Power Class 3	NA	2636.50	41055	Mid-High	LTE Band 41	20	14.0	13.48	0.00	0	09911	QPSK	50	0	0 mm	back	1:1.58	0.584	1.127	0.658	
1 CC Uplink - Power Class 3	NA	2680.00	41490	High	LTE Band 41	20	14.0	13.40	0.01	0	09911	QPSK	50	0	0 mm	back	1:1.58	0.600	1.148	0.689	
1 CC Uplink - Power Class 3	NA	2593.00	40620	Mid	LTE Band 41	20	14.0	13.65	-0.01	0	09911	QPSK	100	0	0 mm	back	1:1.58	0.566	1.084	0.614	
1 CC Uplink - Power Class 2	NA	2593.00	40620	Mid	LTE Band 41	20	14.0	13.95	0.01	0	09911	QPSK	1	0	0 mm	back	12:31	0.438	1.012	0.443	
2 CC Uplink - Power Class 3	PCC	2593.00	40620	Mid	LTE Band 41	20	14.0	14.00	0.02	0	09911	QPSK	1	0	0 mm	back	1:1.58	0.685	1.000	0.685	A12
2 CC Uplink - Power Class 3	SCC	2573.20	40422	Mid								QPSK	1	99							
2 CC Uplink - Power Class 2	PCC	2593.00	40620	Mid	LTE Band 41	20	14.0	14.00	0.02	0	09911	QPSK	1	0	0 mm	back	1:2.31	0.465	1.000	0.465	
2 CC Uplink - Power Class 2	SCC	2573.20	40422	Mid								QPSK	1	99							
1 CC Uplink - Power Class 3	NA	2593.00	40620	Mid	LTE Band 41	20	14.0	13.72	0.04	0	09911	QPSK	1	0	0 mm	top	1:1.58	0.494	1.067	0.527	
1 CC Uplink - Power Class 3	NA	2593.00	40620	Mid	LTE Band 41	20	14.0	13.75	0.03	0	09911	QPSK	50	0	0 mm	top	1:1.58	0.499	1.059	0.528	
ANSI / IEEE C95.1 1992 - SAFETY LIMIT Spatial Peak Uncontrolled Exposure/General Population										Body 1.6 W/kg (mW/g) averaged over 1 gram											

FCC ID: A3LSMT867U		SAR EVALUATION REPORT		Approved by: Quality Manager
Document S/N: 1M1907300131-01-R1.A3L	Test Dates: 08/05/19 - 08/27/19	DUT Type: Portable Tablet	Page 83 of 126	

**Table 10-13
DTS Body SAR**



MEASUREMENT RESULTS																		
FREQUENCY		Mode	Service	Bandwidth [MHz]	Maximum Allowed Power [dBm]	Conducted Power [dBm]	Power Drift [dB]	Spacing	Antenna Config.	Device Serial Number	Data Rate (Mbps)	Side	Duty Cycle (%)	SAR (1g)	Scaling Factor (Power)	Scaling Factor (Duty Cycle)	Reported SAR (1g)	Plot #
MHz	Ch.													(W/kg)			(W/kg)	
2437	6	802.11b	DSSS	22	20.0	19.67	0.06	15 mm	1	09515	1	back	99.1	0.096	1.079	1.009	0.105	
2437	6	802.11b	DSSS	22	20.0	19.67	0.07	14 mm	1	09515	1	top	99.1	0.022	1.079	1.009	0.024	
2437	6	802.11b	DSSS	22	20.0	19.67	0.03	0 mm	1	09515	1	right	99.1	0.004	1.079	1.009	0.004	
2437	6	802.11b	DSSS	22	20.0	19.67	-0.01	8 mm	1	09515	1	left	99.1	0.207	1.079	1.009	0.225	
2462	11	802.11b	DSSS	22	13.5	13.46	-0.13	0 mm	1	09515	1	back	99.1	0.675	1.009	1.009	0.687	
2462	11	802.11b	DSSS	22	13.5	13.46	0.09	0 mm	1	09515	1	top	99.1	0.123	1.009	1.009	0.125	
2412	1	802.11b	DSSS	22	13.5	12.84	-0.07	0 mm	1	09515	1	left	99.1	0.701	1.164	1.009	0.823	
2437	6	802.11b	DSSS	22	13.5	12.80	0.02	0 mm	1	09515	1	left	99.1	0.851	1.175	1.009	1.009	A13
2462	11	802.11b	DSSS	22	13.5	13.46	-0.03	0 mm	1	09515	1	left	99.1	0.768	1.009	1.009	0.782	
2457	10	802.11b	DSSS	22	20.0	19.86	0.03	15 mm	2	09515	1	back	99.0	0.172	1.033	1.010	0.179	
2457	10	802.11b	DSSS	22	20.0	19.86	-0.02	14 mm	2	09515	1	top	99.0	0.353	1.033	1.010	0.368	
2457	10	802.11b	DSSS	22	20.0	19.86	0.07	8 mm	2	09515	1	right	99.0	0.327	1.033	1.010	0.341	
2457	10	802.11b	DSSS	22	20.0	19.86	-0.12	0 mm	2	09515	1	left	99.0	0.017	1.033	1.010	0.018	
2412	1	802.11b	DSSS	22	13.5	13.03	-0.02	0 mm	2	09515	1	back	99.0	0.698	1.114	1.010	0.785	
2437	6	802.11b	DSSS	22	13.5	12.94	0.03	0 mm	2	09515	1	back	99.0	0.694	1.138	1.010	0.798	
2462	11	802.11b	DSSS	22	13.5	12.87	-0.02	0 mm	2	09515	1	back	99.0	0.642	1.156	1.010	0.750	
2412	1	802.11b	DSSS	22	13.5	13.03	0.01	0 mm	2	09515	1	top	99.0	0.343	1.114	1.010	0.386	
2412	1	802.11b	DSSS	22	13.5	13.03	-0.05	0 mm	2	09515	1	right	99.0	0.497	1.114	1.010	0.559	
ANSI / IEEE C95.1 1992 - SAFETY LIMIT								Body										
Spatial Peak								1.6 W/kg (mW/g)										
Uncontrolled Exposure/General Population								averaged over 1 gram										

FCC ID: A3LSMT867U		SAR EVALUATION REPORT		Approved by: Quality Manager
Document S/N: 1M1907300131-01-R1.A3L	Test Dates: 08/05/19 - 08/27/19	DUT Type: Portable Tablet	Page 84 of 126	

**Table 10-14
U-NII Body SAR**

MEASUREMENT RESULTS																			
FREQUENCY		Mode	Service	Bandwidth [MHz]	Maximum Allowed Power [dBm]	Conducted Power [dBm]	Power Drift [dB]	Spacing	Antenna Config.	Device Serial Number	Data Rate (Mbps)	Side	Duty Cycle (%)	SAR (1g) (W/kg)	Scaling Factor (Power)	Scaling Factor (Duty Cycle)	Reported SAR (1g) (W/kg)	Plot #	
MHz	Ch.																		
5260	52	802.11a	OFDM	20	18.0	17.82	0.16	15 mm	1	10109	6	back	98.8	0.015	1.042	1.012	0.016		
5260	52	802.11a	OFDM	20	18.0	17.82	-0.16	14 mm	1	10109	6	top	98.8	0.009	1.042	1.012	0.009		
5260	52	802.11a	OFDM	20	18.0	17.82	-0.09	0 mm	1	10109	6	right	98.8	0.006	1.042	1.012	0.006		
5260	52	802.11a	OFDM	20	18.0	17.82	-0.17	8 mm	1	10109	6	left	98.8	0.077	1.042	1.012	0.081		
5290	58	802.11ac	OFDM	80	9.0	8.95	0.07	0 mm	1	10109	29.3	back	94.5	0.183	1.012	1.058	0.196		
5290	58	802.11ac	OFDM	80	9.0	8.95	0.12	0 mm	1	10109	29.3	top	94.5	0.067	1.012	1.058	0.072		
5290	58	802.11ac	OFDM	80	9.0	8.95	0.05	0 mm	1	10109	29.3	left	94.5	0.198	1.012	1.058	0.212		
5280	56	802.11a	OFDM	20	18.0	17.93	0.18	15 mm	2	10109	6	back	98.7	0.107	1.016	1.013	0.110		
5280	56	802.11a	OFDM	20	18.0	17.93	0.12	14 mm	2	10109	6	top	98.7	0.075	1.016	1.013	0.077		
5280	56	802.11a	OFDM	20	18.0	17.93	-0.05	8 mm	2	10109	6	right	98.7	0.710	1.016	1.013	0.731		
5280	56	802.11a	OFDM	20	18.0	17.93	0.08	0 mm	2	10109	6	left	98.7	0.015	1.016	1.013	0.015		
5290	58	802.11ac	OFDM	80	9.0	9.00	-0.02	0 mm	2	10109	29.3	back	94.5	0.367	1.000	1.058	0.388		
5290	58	802.11ac	OFDM	80	9.0	9.00	-0.09	0 mm	2	10109	29.3	top	94.5	0.154	1.000	1.058	0.163		
5290	58	802.11ac	OFDM	80	9.0	9.00	-0.08	0 mm	2	10109	29.3	right	94.5	0.531	1.000	1.058	0.562		
5500	100	802.11a	OFDM	20	18.0	17.72	0.09	15 mm	1	10109	6	back	98.8	0.027	1.067	1.012	0.029		
5500	100	802.11a	OFDM	20	18.0	17.72	-0.02	14 mm	1	10109	6	top	98.8	0.039	1.067	1.012	0.042		
5500	100	802.11a	OFDM	20	18.0	17.72	-0.06	0 mm	1	10109	6	right	98.8	0.012	1.067	1.012	0.013		
5500	100	802.11a	OFDM	20	18.0	17.72	-0.07	8 mm	1	10109	6	left	98.8	0.436	1.067	1.012	0.471		
5530	106	802.11ac	OFDM	80	9.0	8.96	-0.17	0 mm	1	10109	29.3	back	94.5	0.362	1.009	1.058	0.386		
5530	106	802.11ac	OFDM	80	9.0	8.96	-0.08	0 mm	1	10109	29.3	top	94.5	0.122	1.009	1.058	0.130		
5530	106	802.11ac	OFDM	80	9.0	8.96	-0.07	0 mm	1	10109	29.3	left	94.5	0.620	1.009	1.058	0.662		
5610	122	802.11ac	OFDM	80	9.0	8.80	-0.08	0 mm	1	10109	29.3	left	94.5	0.612	1.047	1.058	0.678		
5690	138	802.11ac	OFDM	80	9.0	8.75	-0.03	0 mm	1	10109	29.3	left	94.5	0.476	1.059	1.058	0.533		
5720	144	802.11a	OFDM	20	18.0	17.96	-0.02	15 mm	2	10109	6	back	98.7	0.129	1.009	1.013	0.132		
5720	144	802.11a	OFDM	20	18.0	17.96	-0.15	14 mm	2	10109	6	top	98.7	0.102	1.009	1.013	0.104		
5500	100	802.11a	OFDM	20	18.0	17.70	0.08	8 mm	2	10109	6	right	98.7	1.080	1.072	1.013	1.173	A14	
5620	124	802.11a	OFDM	20	18.0	17.93	-0.07	8 mm	2	10109	6	right	98.7	1.070	1.016	1.013	1.101		
5720	144	802.11a	OFDM	20	18.0	17.96	0.02	8 mm	2	10109	6	right	98.7	0.955	1.009	1.013	0.976		
5720	144	802.11a	OFDM	20	18.0	17.96	0.08	0 mm	2	10109	6	left	98.7	0.021	1.009	1.013	0.021		
5690	138	802.11ac	OFDM	80	9.0	8.99	0.07	0 mm	2	10109	29.3	back	94.5	0.676	1.002	1.058	0.717		
5690	138	802.11ac	OFDM	80	9.0	8.99	0.05	0 mm	2	10109	29.3	top	94.5	0.252	1.002	1.058	0.267		
5530	106	802.11ac	OFDM	80	9.0	8.92	-0.04	0 mm	2	10109	29.3	right	94.5	0.911	1.019	1.058	0.982		
5610	122	802.11ac	OFDM	80	9.0	8.88	-0.06	0 mm	2	10109	29.3	right	94.5	1.070	1.028	1.058	1.164		
5690	138	802.11ac	OFDM	80	9.0	8.99	-0.04	0 mm	2	10109	29.3	right	94.5	1.070	1.002	1.058	1.134		
5785	157	802.11a	OFDM	20	18.0	17.77	-0.06	15 mm	1	10109	6	back	98.8	0.019	1.054	1.012	0.020		
5785	157	802.11a	OFDM	20	18.0	17.77	-0.07	14 mm	1	10109	6	top	98.8	0.023	1.054	1.012	0.025		
5785	157	802.11a	OFDM	20	18.0	17.77	0.16	0 mm	1	10109	6	right	98.8	0.021	1.054	1.012	0.022		
5785	157	802.11a	OFDM	20	18.0	17.77	0.01	8 mm	1	10109	6	left	98.8	0.407	1.054	1.012	0.434		
5775	155	802.11ac	OFDM	80	9.0	8.91	-0.07	0 mm	1	10109	29.3	back	94.5	0.327	1.021	1.058	0.353		
5775	155	802.11ac	OFDM	80	9.0	8.91	0.12	0 mm	1	10109	29.3	top	94.5	0.081	1.021	1.058	0.087		
5775	155	802.11ac	OFDM	80	9.0	8.91	0.09	0 mm	1	10109	29.3	left	94.5	0.378	1.021	1.058	0.408		
5785	157	802.11a	OFDM	20	18.0	17.95	-0.04	15 mm	2	10109	6	back	98.7	0.099	1.012	1.013	0.101		
5785	157	802.11a	OFDM	20	18.0	17.95	0.06	14 mm	2	10109	6	top	98.7	0.097	1.012	1.013	0.099		
5745	149	802.11a	OFDM	20	18.0	17.95	-0.12	8 mm	2	10109	6	right	98.7	0.903	1.012	1.013	0.926		
5785	157	802.11a	OFDM	20	18.0	17.95	0.00	8 mm	2	10109	6	right	98.7	0.824	1.012	1.013	0.845		
5785	157	802.11a	OFDM	20	18.0	17.95	0.09	0 mm	2	10109	6	left	98.7	0.013	1.012	1.013	0.013		
5775	155	802.11ac	OFDM	80	9.0	9.00	0.04	0 mm	2	10109	29.3	back	94.5	0.652	1.000	1.058	0.690		
5775	155	802.11ac	OFDM	80	9.0	9.00	0.04	0 mm	2	10109	29.3	top	94.5	0.266	1.000	1.058	0.281		
5775	155	802.11ac	OFDM	80	9.0	9.00	0.06	0 mm	2	10109	29.3	right	94.5	0.972	1.000	1.058	1.028		
5500	100	802.11a	OFDM	20	18.0	17.70	0.10	8 mm	2	10109	6	right	98.7	1.070	1.072	1.013	1.162		
5690	138	802.11ac	OFDM	80	9.0	8.99	-0.09	0 mm	2	10109	29.3	right	94.5	1.030	1.002	1.058	1.092		
ANSI / IEEE C95.1 1992 - SAFETY LIMIT										Body									
Spatial Peak										1.6 W/kg (mW/g)									
Uncontrolled Exposure/General Population										averaged over 1 gram									

Note: Blue entries represent variability measurements.

FCC ID: A3LSMT867U		SAR EVALUATION REPORT		Approved by: Quality Manager
Document S/N: 1M1907300131-01-R1.A3L	Test Dates: 08/05/19 - 08/27/19	DUT Type: Portable Tablet	Page 85 of 126	

**Table 10-15
DSS Body SAR**

MEASUREMENT RESULTS																
FREQUENCY		Mode	Service	Maximum Allowed Power [dBm]	Conducted Power [dBm]	Power Drift [dB]	Spacing	Device Serial Number	Data Rate (Mbps)	Side	Duty Cycle (%)	SAR (1g)	Scaling Factor (Cond Power)	Scaling Factor (Duty Cycle)	Reported SAR (1g)	Plot #
MHz	Ch.											(W/kg)			(W/kg)	
2441	39	Bluetooth	FHSS	13.0	12.98	-0.01	0 mm	11354	1	back	77.3	0.492	1.005	1.294	0.640	
2441	39	Bluetooth	FHSS	13.0	12.98	0.19	0 mm	11354	1	top	77.3	0.055	1.005	1.294	0.072	
2441	39	Bluetooth	FHSS	13.0	12.98	0.16	0 mm	11354	1	right	77.3	0.000	1.005	1.294	0.000	
2402	0	Bluetooth	FHSS	13.0	12.82	-0.07	0 mm	11354	1	left	77.3	0.512	1.042	1.294	0.690	
2441	39	Bluetooth	FHSS	13.0	12.98	-0.10	0 mm	11354	1	left	77.3	0.648	1.005	1.294	0.843	A15
2480	78	Bluetooth	FHSS	13.0	12.48	-0.05	0 mm	11354	1	left	77.3	0.632	1.127	1.294	0.922	
ANSI / IEEE C95.1 1992 - SAFETY LIMIT Spatial Peak Uncontrolled Exposure/General Population							Body 1.6 W/kg (mW/g) averaged over 1 gram									

10.2 SAR Test Notes

General Notes:



- The test data reported are the worst-case SAR values according to test procedures specified in FCC KDB Publication 616217 D04v01r02 and FCC KDB Publication 447498 D01v06.
- Batteries are fully charged at the beginning of the SAR measurements.
- Liquid tissue depth was at least 15.0 cm for all frequencies.
- The manufacturer has confirmed that the device(s) tested have the same physical, mechanical and thermal characteristics and are within operational tolerances expected for production units.
- SAR results were scaled to the maximum allowed power to demonstrate compliance per FCC KDB Publication 447498 D01v06.
- Per FCC KDB 865664 D01v01r04, variability SAR tests were performed when the measured SAR results for a frequency band were greater than or equal to 0.8 W/kg. Repeated SAR measurements are highlighted in the tables above for clarity. Please see Section 12 for variability analysis.
- FCC KDB Publication 616217 D04v01r02 Section 4.3, SAR tests are required for the back surface and edges of the tablet with the tablet touching the phantom. The SAR Exclusion Threshold in FCC KDB 447498 D01v06 was applied to determine SAR test exclusion for adjacent edge configurations.
- This device supports dynamic antenna tuning for some bands. Per April 2019 Workshop Notes, SAR was measured according to the normally required SAR measurement configurations with tuner active. The auto-tune state determined by the device was verified before and after each SAR measurement and is listed in tables above. Please see Section 13 for supplemental data.

UMTS Notes:

- UMTS mode in was tested under RMC 12.2 kbps with HSPA Inactive per KDB Publication 941225 D01v03r01. AMR and HSPA SAR was not required per the 3G Test Reduction Procedure in KDB Publication 941225 D01v03r01.
- Per FCC KDB Publication 447498 D01v06, if the reported (scaled) SAR measured at the middle channel or highest output power channel for each test configuration is ≤ 0.8 W/kg for 1g evaluations then testing at the other channels is not required for such test configuration(s). When the maximum output power variation across the required test channels is $> \frac{1}{2}$ dB, instead of the middle channel, the highest output power channel was used.

LTE Notes:

- LTE Considerations: LTE test configurations are determined according to SAR Evaluation Considerations for LTE Devices in FCC KDB Publication 941225 D05v02r04. The general test procedures used for testing can be found in Section 7.5.4.

FCC ID: A3LSMT867U		SAR EVALUATION REPORT		Approved by: Quality Manager
Document S/N: 1M1907300131-01-R1.A3L	Test Dates: 08/05/19 - 08/27/19	DUT Type: Portable Tablet	Page 86 of 126	



2. MPR is permanently implemented for this device by the manufacturer. The specific manufacturer target MPR is indicated alongside the SAR results. MPR is enabled for this device, according to 3GPP TS36.101 Section 6.2.3 – 6.2.5 under Table 6.2.3-1.
3. A-MPR was disabled for all SAR tests by setting NS=01 and MCC=001 on the base station simulator. SAR tests were performed with the same number of RB and RB offsets transmitting on all TTI frames (maximum TTI).
4. Per FCC KDB Publication 447498 D01v06, when the reported LTE Band 41 SAR measured at the highest output power channel in a given a test configuration was > 0.6 W/kg for 1g evaluations, testing at the other channels was required for such test configurations.
5. TDD LTE was tested per the guidance provided in FCC KDB Publication 941225 D05v02r04. Testing was performed using UL-DL configuration 0 with 6 UL subframes and 2 S subframes using extended cyclic prefix only and special subframe configuration 6. SAR tests were performed at maximum output power and worst-case transmission duty factor in extended cyclic prefix. Per 3GPP 36.211 Section 4, the duty factor for special subframe configuration 6 using extended cyclic prefix is 0.633.
6. Per KDB Publication 941225 D05Av01r02, SAR for downlink only LTE CA operations was not needed since the maximum average output power in LTE CA mode was not >0.25 dB higher than the maximum output power when downlink carrier aggregation was inactive. This device supports Power Class 2 and Power Class 3 operations for LTE Band 41. The highest available duty cycle for Power Class 2 operations is 43.3 % using UL-DL configuration 1. Per FCC Guidance, all SAR tests were performed using Power Class 3. SAR with power class 2 at the available duty factor was additionally performed for the power class 3 configuration with the highest SAR configuration for each exposure conditions. Please see Section 13 for linearity results.
7. For LTE Band 66 and Band 41, per FCC guidance, SAR was first measured with only a single carrier active in the uplink (carrier aggregation not active). For each exposure condition, the uplink CA scenario with two component carriers was additionally tested for the configuration with the highest SAR when carrier aggregation was not active. The SCC was configured with the closest available contiguous channel. The two component carriers were configured so the resource blocks are physically allocated side by side to achieve the maximum output power.

WLAN Notes:

1. Justification for test configurations for WLAN per KDB Publication 248227 D01v02r02 for 2.4 GHz WIFI single transmission chain operations, the highest measured maximum output power channel for DSSS was selected for SAR measurement. SAR for OFDM modes (2.4 GHz 802.11g/n) was not required due to the maximum allowed powers and the highest reported DSSS SAR. See Section 7.6.4 for more information.
2. Justification for test configurations for WLAN per KDB Publication 248227 D01v02r02 for 5 GHz WIFI single transmission chain operations, the initial test configuration was selected according to the transmission mode with the highest maximum allowed powers. Other transmission modes were not investigated since the highest reported SAR for initial test configuration adjusted by the ratio of maximum output powers is less than 1.2 W/kg for 1g evaluations. See Section 7.6.5 for more information.
3. Per KDB Publication 248227 D01v02r02, SAR for MIMO was evaluated by following the simultaneous SAR provisions from KDB Publication 447498 D01v06 by either evaluating the sum of the 1g SAR values of each antenna transmitting independently or making a SAR measurement with both antennas transmitting simultaneously. Please see Section 11 for complete analysis.
4. When the maximum reported 1g averaged SAR is ≤0.8 W/kg, SAR testing on additional channels was not required. Otherwise, SAR for the next highest output power channel was required until the reported SAR result was ≤ 1.20 W/kg for 1g evaluations or all test channels were measured.
5. The device was configured to transmit continuously at the required data rate, channel bandwidth and signal modulation, using the highest transmission duty factor supported by the test mode tools. The reported SAR was scaled to the 100% transmission duty factor to determine compliance. Procedures used to measure the duty factor are identical to that in the associated EMC test reports.

Bluetooth Notes

1. Bluetooth SAR was measured with the device connected to a call box with hopping disabled with DH5 operation and Tx Tests test mode type. Per October 2016 TCB Workshop Notes, the reported SAR was scaled to the 100% transmission duty factor to determine compliance. See Section 8.5 for the time domain plot and calculation for the duty factor of the device.

FCC ID: A3LSMT867U		SAR EVALUATION REPORT		Approved by: Quality Manager
Document S/N: 1M1907300131-01-R1.A3L	Test Dates: 08/05/19 - 08/27/19	DUT Type: Portable Tablet	Page 87 of 126	

11 FCC MULTI-TX AND ANTENNA SAR CONSIDERATIONS

11.1 Introduction



The following procedures adopted from FCC KDB Publication 447498 D01v06 are applicable to devices with built-in unlicensed transmitters such as 802.11 and Bluetooth devices which may simultaneously transmit with the licensed transmitter.

11.2 Simultaneous Transmission Procedures



This device contains transmitters that may operate simultaneously. Therefore, simultaneous transmission analysis is required. Per FCC KDB Publication 447498 D01v06 4.3.2 and IEEE 1528-2013 Section 6.3.4.1.2, simultaneous transmission SAR test exclusion may be applied when the sum of the 1g SAR for all the simultaneous transmitting antennas in a specific a physical test configuration is ≤ 1.6 W/kg. The different test positions in an exposure condition may be considered collectively to determine SAR test exclusion according to the sum of 1g SAR.

Table 11-1
Simultaneous Transmission Scenario with 2.4 GHz WLAN

Simult Tx	Configuration	UMTS 850 SAR (W/kg)	2.4 GHz WLAN Ant 1 SAR (W/kg)	2.4 GHz WLAN Ant 2 SAR (W/kg)	Σ SAR (W/kg)			SPLSR		
		1	2	3	1+2	1+3	1+2+3	1+2	1+3	2+3
Body SAR	Back	1.113	0.687	0.798	See Note 1	See Note 1	See Note 1	0.04	0.03	0.01
	Top	1.056	0.125	0.386	1.181	1.442	1.567	N/A	N/A	N/A
	Bottom	0.400	0.400	0.400	0.800	0.800	1.200	N/A	N/A	N/A
	Right	0.242	0.004	0.559	0.246	0.801	0.805	N/A	N/A	N/A
	Left	0.132	1.009	0.018	1.141	0.150	1.159	N/A	N/A	N/A
Simult Tx	Configuration	UMTS 1750 SAR (W/kg)	2.4 GHz WLAN Ant 1 SAR (W/kg)	2.4 GHz WLAN Ant 2 SAR (W/kg)	Σ SAR (W/kg)			SPLSR		
		1	2	3	1+2	1+3	1+2+3	1+2	1+3	2+3
Body SAR	Back	1.049	0.687	0.798	See Note 1	See Note 1	See Note 1	0.04	0.03	0.01
	Top	0.751	0.125	0.386	0.876	1.137	1.262	N/A	N/A	N/A
	Bottom	0.400	0.400	0.400	0.800	0.800	1.200	N/A	N/A	N/A
	Right	0.166	0.004	0.559	0.170	0.725	0.729	N/A	N/A	N/A
	Left	0.208	1.009	0.018	1.217	0.226	1.235	N/A	N/A	N/A
Simult Tx	Configuration	UMTS 1900 SAR (W/kg)	2.4 GHz WLAN Ant 1 SAR (W/kg)	2.4 GHz WLAN Ant 2 SAR (W/kg)	Σ SAR (W/kg)			SPLSR		
		1	2	3	1+2	1+3	1+2+3	1+2	1+3	2+3
Body SAR	Back	0.925	0.687	0.798	See Note 1	See Note 1	See Note 1	0.03	0.03	0.01
	Top	0.757	0.125	0.386	0.882	1.143	1.268	N/A	N/A	N/A
	Bottom	0.400	0.400	0.400	0.800	0.800	1.200	N/A	N/A	N/A
	Right	0.212	0.004	0.559	0.216	0.771	0.775	N/A	N/A	N/A
	Left	0.102	1.009	0.018	1.111	0.120	1.129	N/A	N/A	N/A

FCC ID: A3LSMT867U		SAR EVALUATION REPORT		Approved by: Quality Manager
Document S/N: 1M1907300131-01-R1.A3L	Test Dates: 08/05/19 - 08/27/19	DUT Type: Portable Tablet	Page 88 of 126	

Simult Tx	Configuration	LTE Band 71 SAR (W/kg)	2.4 GHz WLAN Ant 1 SAR (W/kg)	2.4 GHz WLAN Ant 2 SAR (W/kg)	Σ SAR (W/kg)			SPLSR		
		1	2	3	1+2	1+3	1+2+3	1+2	1+3	2+3
Body SAR	Back	0.531	0.687	0.798	1.218	1.329	See Note 1	0.03	0.02	0.01
	Top	0.693	0.125	0.386	0.818	1.079	1.204	N/A	N/A	N/A
	Bottom	0.400	0.400	0.400	0.800	0.800	1.200	N/A	N/A	N/A
	Right	0.121	0.004	0.559	0.125	0.680	0.684	N/A	N/A	N/A
	Left	0.122	1.009	0.018	1.131	0.140	1.149	N/A	N/A	N/A
Simult Tx	Configuration	LTE Band 12 SAR (W/kg)	2.4 GHz WLAN Ant 1 SAR (W/kg)	2.4 GHz WLAN Ant 2 SAR (W/kg)	Σ SAR (W/kg)			SPLSR		
		1	2	3	1+2	1+3	1+2+3	1+2	1+3	2+3
Body SAR	Back	0.700	0.687	0.798	1.387	1.498	See Note 1	0.02	0.02	0.01
	Top	0.869	0.125	0.386	0.994	1.255	1.380	N/A	N/A	N/A
	Bottom	0.400	0.400	0.400	0.800	0.800	1.200	N/A	N/A	N/A
	Right	0.152	0.004	0.559	0.156	0.711	0.715	N/A	N/A	N/A
	Left	0.162	1.009	0.018	1.171	0.180	1.189	N/A	N/A	N/A
Simult Tx	Configuration	LTE Band 13 SAR (W/kg)	2.4 GHz WLAN Ant 1 SAR (W/kg)	2.4 GHz WLAN Ant 2 SAR (W/kg)	Σ SAR (W/kg)			SPLSR		
		1	2	3	1+2	1+3	1+2+3	1+2	1+3	2+3
Body SAR	Back	1.206	0.687	0.798	See Note 1	See Note 1	See Note 1	0.04	0.04	0.01
	Top	1.172	0.125	0.386	1.297	1.558	See Note 1	0.03	0.02	0.00
	Bottom	0.400	0.400	0.400	0.800	0.800	1.200	N/A	N/A	N/A
	Right	0.233	0.004	0.559	0.237	0.792	0.796	N/A	N/A	N/A
	Left	0.142	1.009	0.018	1.151	0.160	1.169	N/A	N/A	N/A
Simult Tx	Configuration	LTE Band 26 (Cell) SAR (W/kg)	2.4 GHz WLAN Ant 1 SAR (W/kg)	2.4 GHz WLAN Ant 2 SAR (W/kg)	Σ SAR (W/kg)			SPLSR		
		1	2	3	1+2	1+3	1+2+3	1+2	1+3	2+3
Body SAR	Back	1.033	0.687	0.798	See Note 1	See Note 1	See Note 1	0.03	0.04	0.01
	Top	1.036	0.125	0.386	1.161	1.422	1.547	N/A	N/A	N/A
	Bottom	0.400	0.400	0.400	0.800	0.800	1.200	N/A	N/A	N/A
	Right	0.302	0.004	0.559	0.306	0.861	0.865	N/A	N/A	N/A
	Left	0.126	1.009	0.018	1.135	0.144	1.153	N/A	N/A	N/A
Simult Tx	Configuration	LTE Band 66 (AWS) SAR (W/kg)	2.4 GHz WLAN Ant 1 SAR (W/kg)	2.4 GHz WLAN Ant 2 SAR (W/kg)	Σ SAR (W/kg)			SPLSR		
		1	2	3	1+2	1+3	1+2+3	1+2	1+3	2+3
Body SAR	Back	1.060	0.687	0.798	See Note 1	See Note 1	See Note 1	0.04	0.03	0.01
	Top	0.931	0.125	0.386	1.056	1.317	1.442	N/A	N/A	N/A
	Bottom	0.400	0.400	0.400	0.800	0.800	1.200	N/A	N/A	N/A
	Right	0.169	0.004	0.559	0.173	0.728	0.732	N/A	N/A	N/A
	Left	0.275	1.009	0.018	1.284	0.293	1.302	N/A	N/A	N/A

FCC ID: A3LSMT867U	 PCTEST ENGINEERING LABORATORY, INC.	SAR EVALUATION REPORT		Approved by: Quality Manager
Document S/N: 1M1907300131-01-R1.A3L	Test Dates: 08/05/19 - 08/27/19	DUT Type: Portable Tablet	Page 89 of 126	

Simult Tx	Configuration	LTE Band 2 (PCS) SAR (W/kg)	2.4 GHz WLAN Ant 1 SAR (W/kg)	2.4 GHz WLAN Ant 2 SAR (W/kg)	Σ SAR (W/kg)			SPLSR		
		1	2	3	1+2	1+3	1+2+3	1+2	1+3	2+3
Body SAR	Back	0.961	0.687	0.798	See Note 1	See Note 1	See Note 1	0.04	0.03	0.01
	Top	0.852	0.125	0.386	0.977	1.238	1.363	N/A	N/A	N/A
	Bottom	0.400	0.400	0.400	0.800	0.800	1.200	N/A	N/A	N/A
	Right	0.181	0.004	0.559	0.185	0.740	0.744	N/A	N/A	N/A
	Left	0.113	1.009	0.018	1.122	0.131	1.140	N/A	N/A	N/A
Simult Tx	Configuration	LTE Band 25 (PCS) SAR (W/kg)	2.4 GHz WLAN Ant 1 SAR (W/kg)	2.4 GHz WLAN Ant 2 SAR (W/kg)	Σ SAR (W/kg)			SPLSR		
		1	2	3	1+2	1+3	1+2+3	1+2	1+3	2+3
Body SAR	Back	1.066	0.687	0.798	See Note 1	See Note 1	See Note 1	0.04	0.03	0.01
	Top	0.700	0.125	0.386	0.825	1.086	1.211	N/A	N/A	N/A
	Bottom	0.400	0.400	0.400	0.800	0.800	1.200	N/A	N/A	N/A
	Right	0.186	0.004	0.559	0.190	0.745	0.749	N/A	N/A	N/A
	Left	0.112	1.009	0.018	1.121	0.130	1.139	N/A	N/A	N/A
Simult Tx	Configuration	LTE Band 7 SAR (W/kg)	2.4 GHz WLAN Ant 1 SAR (W/kg)	2.4 GHz WLAN Ant 2 SAR (W/kg)	Σ SAR (W/kg)			SPLSR		
		1	2	3	1+2	1+3	1+2+3	1+2	1+3	2+3
Body SAR	Back	1.133	0.687	0.798	See Note 1	See Note 1	See Note 1	0.03	0.04	0.01
	Top	1.144	0.125	0.386	1.269	1.530	See Note 1	0.01	0.04	0.00
	Bottom	0.400	0.400	0.400	0.800	0.800	1.200	N/A	N/A	N/A
	Right	0.347	0.004	0.559	0.351	0.906	0.910	N/A	N/A	N/A
	Left	0.356	1.009	0.018	1.365	0.374	1.383	N/A	N/A	N/A
Simult Tx	Configuration	LTE Band 41 SAR (W/kg)	2.4 GHz WLAN Ant 1 SAR (W/kg)	2.4 GHz WLAN Ant 2 SAR (W/kg)	Σ SAR (W/kg)			SPLSR		
		1	2	3	1+2	1+3	1+2+3	1+2	1+3	2+3
Body SAR	Back	0.697	0.687	0.798	1.384	1.495	See Note 1	0.02	0.03	0.01
	Top	0.528	0.125	0.386	0.653	0.914	1.039	N/A	N/A	N/A
	Bottom	0.400	0.400	0.400	0.800	0.800	1.200	N/A	N/A	N/A
	Right	0.268	0.004	0.559	0.272	0.827	0.831	N/A	N/A	N/A
	Left	0.475	1.009	0.018	1.484	0.493	1.502	N/A	N/A	N/A







FCC ID: A3LSMT867U		SAR EVALUATION REPORT		Approved by: Quality Manager
Document S/N: 1M1907300131-01-R1.A3L	Test Dates: 08/05/19 - 08/27/19	DUT Type: Portable Tablet	Page 90 of 126	

Table 11-2
Simultaneous Transmission Scenario with 5 GHz WLAN

Simult Tx	Configuration	UMTS 850 SAR (W/kg)	5 GHz WLAN Ant 1 SAR (W/kg)	5 GHz WLAN Ant 2 SAR (W/kg)	Σ SAR (W/kg)			SPLSR		
		1	2	3	1+2	1+3	1+2+3	1+2	1+3	2+3
Body SAR	Back	1.113	0.386	0.717	1.499	See Note 1	See Note 1	0.03	0.03	0.01
	Top	1.056	0.130	0.281	1.186	1.337	1.467	N/A	N/A	N/A
	Bottom	0.400	0.400	0.400	0.800	0.800	1.200	N/A	N/A	N/A
	Right	0.242	0.022	1.173	0.264	1.415	1.437	N/A	N/A	N/A
	Left	0.132	0.678	0.021	0.810	0.153	0.831	N/A	N/A	N/A
Simult Tx	Configuration	UMTS 1750 SAR (W/kg)	5 GHz WLAN Ant 1 SAR (W/kg)	5 GHz WLAN Ant 2 SAR (W/kg)	Σ SAR (W/kg)			SPLSR		
		1	2	3	1+2	1+3	1+2+3	1+2	1+3	2+3
Body SAR	Back	1.049	0.386	0.717	1.435	See Note 1	See Note 1	0.02	0.03	0.01
	Top	0.751	0.130	0.281	0.881	1.032	1.162	N/A	N/A	N/A
	Bottom	0.400	0.400	0.400	0.800	0.800	1.200	N/A	N/A	N/A
	Right	0.166	0.022	1.173	0.188	1.339	1.361	N/A	N/A	N/A
	Left	0.208	0.678	0.021	0.886	0.229	0.907	N/A	N/A	N/A
Simult Tx	Configuration	UMTS 1900 SAR (W/kg)	5 GHz WLAN Ant 1 SAR (W/kg)	5 GHz WLAN Ant 2 SAR (W/kg)	Σ SAR (W/kg)			SPLSR		
		1	2	3	1+2	1+3	1+2+3	1+2	1+3	2+3
Body SAR	Back	0.925	0.386	0.717	1.311	See Note 1	See Note 1	0.02	0.03	0.01
	Top	0.757	0.130	0.281	0.887	1.038	1.168	N/A	N/A	N/A
	Bottom	0.400	0.400	0.400	0.800	0.800	1.200	N/A	N/A	N/A
	Right	0.212	0.022	1.173	0.234	1.385	1.407	N/A	N/A	N/A
	Left	0.102	0.678	0.021	0.780	0.123	0.801	N/A	N/A	N/A
Simult Tx	Configuration	LTE Band 71 SAR (W/kg)	5 GHz WLAN Ant 1 SAR (W/kg)	5 GHz WLAN Ant 2 SAR (W/kg)	Σ SAR (W/kg)			SPLSR		
		1	2	3	1+2	1+3	1+2+3	1+2	1+3	2+3
Body SAR	Back	0.531	0.386	0.717	0.917	1.248	See Note 1	0.01	0.02	0.01
	Top	0.693	0.130	0.281	0.823	0.974	1.104	N/A	N/A	N/A
	Bottom	0.400	0.400	0.400	0.800	0.800	1.200	N/A	N/A	N/A
	Right	0.121	0.022	1.173	0.143	1.294	1.316	N/A	N/A	N/A
	Left	0.122	0.678	0.021	0.800	0.143	0.821	N/A	N/A	N/A
Simult Tx	Configuration	LTE Band 12 SAR (W/kg)	5 GHz WLAN Ant 1 SAR (W/kg)	5 GHz WLAN Ant 2 SAR (W/kg)	Σ SAR (W/kg)			SPLSR		
		1	2	3	1+2	1+3	1+2+3	1+2	1+3	2+3
Body SAR	Back	0.700	0.386	0.717	1.086	1.417	See Note 1	0.01	0.02	0.01
	Top	0.869	0.130	0.281	0.999	1.150	1.280	N/A	N/A	N/A
	Bottom	0.400	0.400	0.400	0.800	0.800	1.200	N/A	N/A	N/A
	Right	0.152	0.022	1.173	0.174	1.325	1.347	N/A	N/A	N/A
	Left	0.162	0.678	0.021	0.840	0.183	0.861	N/A	N/A	N/A

FCC ID: A3LSMT867U	 PCTEST ENGINEERING LABORATORY, INC.	SAR EVALUATION REPORT		Approved by: Quality Manager
Document S/N: 1M1907300131-01-R1.A3L	Test Dates: 08/05/19 - 08/27/19	DUT Type: Portable Tablet		Page 91 of 126

Simult Tx	Configuration	LTE Band 13 SAR (W/kg)	5 GHz WLAN Ant 1 SAR (W/kg)	5 GHz WLAN Ant 2 SAR (W/kg)	Σ SAR (W/kg)			SPLSR		
		1	2	3	1+2	1+3	1+2+3	1+2	1+3	2+3
Body SAR	Back	1.206	0.386	0.717	1.592	See Note 1	See Note 1	0.03	0.04	0.01
	Top	1.172	0.130	0.281	1.302	1.453	1.583	N/A	N/A	N/A
	Bottom	0.400	0.400	0.400	0.800	0.800	1.200	N/A	N/A	N/A
	Right	0.233	0.022	1.173	0.255	1.406	1.428	N/A	N/A	N/A
	Left	0.142	0.678	0.021	0.820	0.163	0.841	N/A	N/A	N/A
Simult Tx	Configuration	LTE Band 26 (Cell) SAR (W/kg)	5 GHz WLAN Ant 1 SAR (W/kg)	5 GHz WLAN Ant 2 SAR (W/kg)	Σ SAR (W/kg)			SPLSR		
		1	2	3	1+2	1+3	1+2+3	1+2	1+3	2+3
Body SAR	Back	1.033	0.386	0.717	1.419	See Note 1	See Note 1	0.02	0.04	0.01
	Top	1.036	0.130	0.281	1.166	1.317	1.447	N/A	N/A	N/A
	Bottom	0.400	0.400	0.400	0.800	0.800	1.200	N/A	N/A	N/A
	Right	0.302	0.022	1.173	0.324	1.475	1.497	N/A	N/A	N/A
	Left	0.126	0.678	0.021	0.804	0.147	0.825	N/A	N/A	N/A
Simult Tx	Configuration	LTE Band 66 (AWS) SAR (W/kg)	5 GHz WLAN Ant 1 SAR (W/kg)	5 GHz WLAN Ant 2 SAR (W/kg)	Σ SAR (W/kg)			SPLSR		
		1	2	3	1+2	1+3	1+2+3	1+2	1+3	2+3
Body SAR	Back	1.060	0.386	0.717	1.446	See Note 1	See Note 1	0.03	0.03	0.01
	Top	0.931	0.130	0.281	1.061	1.212	1.342	N/A	N/A	N/A
	Bottom	0.400	0.400	0.400	0.800	0.800	1.200	N/A	N/A	N/A
	Right	0.169	0.022	1.173	0.191	1.342	1.364	N/A	N/A	N/A
	Left	0.275	0.678	0.021	0.953	0.296	0.974	N/A	N/A	N/A
Simult Tx	Configuration	LTE Band 2 (PCS) SAR (W/kg)	5 GHz WLAN Ant 1 SAR (W/kg)	5 GHz WLAN Ant 2 SAR (W/kg)	Σ SAR (W/kg)			SPLSR		
		1	2	3	1+2	1+3	1+2+3	1+2	1+3	2+3
Body SAR	Back	0.961	0.386	0.717	1.347	See Note 1	See Note 1	0.02	0.03	0.01
	Top	0.852	0.130	0.281	0.982	1.133	1.263	N/A	N/A	N/A
	Bottom	0.400	0.400	0.400	0.800	0.800	1.200	N/A	N/A	N/A
	Right	0.181	0.022	1.173	0.203	1.354	1.376	N/A	N/A	N/A
	Left	0.113	0.678	0.021	0.791	0.134	0.812	N/A	N/A	N/A
Simult Tx	Configuration	LTE Band 25 (PCS) SAR (W/kg)	5 GHz WLAN Ant 1 SAR (W/kg)	5 GHz WLAN Ant 2 SAR (W/kg)	Σ SAR (W/kg)			SPLSR		
		1	2	3	1+2	1+3	1+2+3	1+2	1+3	2+3
Body SAR	Back	1.066	0.386	0.717	1.452	See Note 1	See Note 1	0.03	0.03	0.01
	Top	0.700	0.130	0.281	0.830	0.981	1.111	N/A	N/A	N/A
	Bottom	0.400	0.400	0.400	0.800	0.800	1.200	N/A	N/A	N/A
	Right	0.186	0.022	1.173	0.208	1.359	1.381	N/A	N/A	N/A
	Left	0.112	0.678	0.021	0.790	0.133	0.811	N/A	N/A	N/A

FCC ID: A3LSMT867U	 PCTEST ENGINEERING LABORATORY, INC.	SAR EVALUATION REPORT		Approved by: Quality Manager
Document S/N: 1M1907300131-01-R1.A3L	Test Dates: 08/05/19 - 08/27/19	DUT Type: Portable Tablet		Page 92 of 126

Simult Tx	Configuration	LTE Band 7 SAR (W/kg)	5 GHz WLAN Ant 1 SAR (W/kg)	5 GHz WLAN Ant 2 SAR (W/kg)	Σ SAR (W/kg)			SPLSR		
		1	2	3	1+2	1+3	1+2+3	1+2	1+3	2+3
Body SAR	Back	1.133	0.386	0.717	1.519	See Note 1	See Note 1	0.02	0.04	0.01
	Top	1.144	0.130	0.281	1.274	1.425	1.555	N/A	N/A	N/A
	Bottom	0.400	0.400	0.400	0.800	0.800	1.200	N/A	N/A	N/A
	Right	0.347	0.022	1.173	0.369	1.520	1.542	N/A	N/A	N/A
	Left	0.356	0.678	0.021	1.034	0.377	1.055	N/A	N/A	N/A
Simult Tx	Configuration	LTE Band 41 SAR (W/kg)	5 GHz WLAN Ant 1 SAR (W/kg)	5 GHz WLAN Ant 2 SAR (W/kg)	Σ SAR (W/kg)			SPLSR		
		1	2	3	1+2	1+3	1+2+3	1+2	1+3	2+3
Body SAR	Back	0.697	0.386	0.717	1.083	1.414	See Note 1	0.01	0.03	0.01
	Top	0.528	0.130	0.281	0.658	0.809	0.939	N/A	N/A	N/A
	Bottom	0.400	0.400	0.400	0.800	0.800	1.200	N/A	N/A	N/A
	Right	0.268	0.022	1.173	0.290	1.441	1.463	N/A	N/A	N/A
	Left	0.475	0.678	0.021	1.153	0.496	1.174	N/A	N/A	N/A







FCC ID: A3LSMT867U	 PCTEST ENGINEERING LABORATORY, INC.	SAR EVALUATION REPORT		Approved by: Quality Manager
Document S/N: 1M1907300131-01-R1.A3L	Test Dates: 08/05/19 - 08/27/19	DUT Type: Portable Tablet	Page 93 of 126	

Table 11-3
Simultaneous Transmission Scenario with 2.4 GHz WLAN Ant 1 and 5 GHz WLAN Ant 2

Simult Tx	Configuration	UMTS 850 SAR (W/kg)	2.4 GHz WLAN Ant 1 SAR (W/kg)	5 GHz WLAN Ant 2 SAR (W/kg)	Σ SAR (W/kg)			SPLSR		
		1	2	3	1+2	1+3	1+2+3	1+2	1+3	2+3
Body SAR	Back	1.113	0.687	0.717	See Note 1	See Note 1	See Note 1	0.04	0.03	0.01
	Top	1.056	0.125	0.281	1.181	1.337	1.462	N/A	N/A	N/A
	Bottom	0.400	0.400	0.400	0.800	0.800	1.200	N/A	N/A	N/A
	Right	0.242	0.004	1.173	0.246	1.415	1.419	N/A	N/A	N/A
	Left	0.132	1.009	0.021	1.141	0.153	1.162	N/A	N/A	N/A
Simult Tx	Configuration	UMTS 1750 SAR (W/kg)	2.4 GHz WLAN Ant 1 SAR (W/kg)	5 GHz WLAN Ant 2 SAR (W/kg)	Σ SAR (W/kg)			SPLSR		
		1	2	3	1+2	1+3	1+2+3	1+2	1+3	2+3
Body SAR	Back	1.049	0.687	0.717	See Note 1	See Note 1	See Note 1	0.04	0.03	0.01
	Top	0.751	0.125	0.281	0.876	1.032	1.157	N/A	N/A	N/A
	Bottom	0.400	0.400	0.400	0.800	0.800	1.200	N/A	N/A	N/A
	Right	0.166	0.004	1.173	0.170	1.339	1.343	N/A	N/A	N/A
	Left	0.208	1.009	0.021	1.217	0.229	1.238	N/A	N/A	N/A
Simult Tx	Configuration	UMTS 1900 SAR (W/kg)	2.4 GHz WLAN Ant 1 SAR (W/kg)	5 GHz WLAN Ant 2 SAR (W/kg)	Σ SAR (W/kg)			SPLSR		
		1	2	3	1+2	1+3	1+2+3	1+2	1+3	2+3
Body SAR	Back	0.925	0.687	0.717	See Note 1	See Note 1	See Note 1	0.03	0.03	0.01
	Top	0.757	0.125	0.281	0.882	1.038	1.163	N/A	N/A	N/A
	Bottom	0.400	0.400	0.400	0.800	0.800	1.200	N/A	N/A	N/A
	Right	0.212	0.004	1.173	0.216	1.385	1.389	N/A	N/A	N/A
	Left	0.102	1.009	0.021	1.111	0.123	1.132	N/A	N/A	N/A
Simult Tx	Configuration	LTE Band 71 SAR (W/kg)	2.4 GHz WLAN Ant 1 SAR (W/kg)	5 GHz WLAN Ant 2 SAR (W/kg)	Σ SAR (W/kg)			SPLSR		
		1	2	3	1+2	1+3	1+2+3	1+2	1+3	2+3
Body SAR	Back	0.531	0.687	0.717	1.218	1.248	See Note 1	0.03	0.02	0.01
	Top	0.693	0.125	0.281	0.818	0.974	1.099	N/A	N/A	N/A
	Bottom	0.400	0.400	0.400	0.800	0.800	1.200	N/A	N/A	N/A
	Right	0.121	0.004	1.173	0.125	1.294	1.298	N/A	N/A	N/A
	Left	0.122	1.009	0.021	1.131	0.143	1.152	N/A	N/A	N/A
Simult Tx	Configuration	LTE Band 12 SAR (W/kg)	2.4 GHz WLAN Ant 1 SAR (W/kg)	5 GHz WLAN Ant 2 SAR (W/kg)	Σ SAR (W/kg)			SPLSR		
		1	2	3	1+2	1+3	1+2+3	1+2	1+3	2+3
Body SAR	Back	0.700	0.687	0.717	1.387	1.417	See Note 1	0.02	0.02	0.01
	Top	0.869	0.125	0.281	0.994	1.150	1.275	N/A	N/A	N/A
	Bottom	0.400	0.400	0.400	0.800	0.800	1.200	N/A	N/A	N/A
	Right	0.152	0.004	1.173	0.156	1.325	1.329	N/A	N/A	N/A
	Left	0.162	1.009	0.021	1.171	0.183	1.192	N/A	N/A	N/A

FCC ID: A3LSMT867U	 PCTEST Engineering Laboratory, Inc.	SAR EVALUATION REPORT		Approved by: Quality Manager
Document S/N: 1M1907300131-01-R1.A3L	Test Dates: 08/05/19 - 08/27/19	DUT Type: Portable Tablet	Page 94 of 126	

Simult Tx	Configuration	LTE Band 13 SAR (W/kg)	2.4 GHz WLAN Ant 1 SAR (W/kg)	5 GHz WLAN Ant 2 SAR (W/kg)	Σ SAR (W/kg)			SPLSR		
		1	2	3	1+2	1+3	1+2+3	1+2	1+3	2+3
Body SAR	Back	1.206	0.687	0.717	See Note 1	See Note 1	See Note 1	0.04	0.04	0.01
	Top	1.172	0.125	0.281	1.297	1.453	1.578	N/A	N/A	N/A
	Bottom	0.400	0.400	0.400	0.800	0.800	1.200	N/A	N/A	N/A
	Right	0.233	0.004	1.173	0.237	1.406	1.410	N/A	N/A	N/A
	Left	0.142	1.009	0.021	1.151	0.163	1.172	N/A	N/A	N/A
Simult Tx	Configuration	LTE Band 26 (Cell) SAR (W/kg)	2.4 GHz WLAN Ant 1 SAR (W/kg)	5 GHz WLAN Ant 2 SAR (W/kg)	Σ SAR (W/kg)			SPLSR		
		1	2	3	1+2	1+3	1+2+3	1+2	1+3	2+3
Body SAR	Back	1.033	0.687	0.717	See Note 1	See Note 1	See Note 1	0.03	0.04	0.01
	Top	1.036	0.125	0.281	1.161	1.317	1.442	N/A	N/A	N/A
	Bottom	0.400	0.400	0.400	0.800	0.800	1.200	N/A	N/A	N/A
	Right	0.302	0.004	1.173	0.306	1.475	1.479	N/A	N/A	N/A
	Left	0.126	1.009	0.021	1.135	0.147	1.156	N/A	N/A	N/A
Simult Tx	Configuration	LTE Band 66 (AWS) SAR (W/kg)	2.4 GHz WLAN Ant 1 SAR (W/kg)	5 GHz WLAN Ant 2 SAR (W/kg)	Σ SAR (W/kg)			SPLSR		
		1	2	3	1+2	1+3	1+2+3	1+2	1+3	2+3
Body SAR	Back	1.060	0.687	0.717	See Note 1	See Note 1	See Note 1	0.04	0.03	0.01
	Top	0.931	0.125	0.281	1.056	1.212	1.337	N/A	N/A	N/A
	Bottom	0.400	0.400	0.400	0.800	0.800	1.200	N/A	N/A	N/A
	Right	0.169	0.004	1.173	0.173	1.342	1.346	N/A	N/A	N/A
	Left	0.275	1.009	0.021	1.284	0.296	1.305	N/A	N/A	N/A
Simult Tx	Configuration	LTE Band 2 (PCS) SAR (W/kg)	2.4 GHz WLAN Ant 1 SAR (W/kg)	5 GHz WLAN Ant 2 SAR (W/kg)	Σ SAR (W/kg)			SPLSR		
		1	2	3	1+2	1+3	1+2+3	1+2	1+3	2+3
Body SAR	Back	0.961	0.687	0.717	See Note 1	See Note 1	See Note 1	0.04	0.03	0.01
	Top	0.852	0.125	0.281	0.977	1.133	1.258	N/A	N/A	N/A
	Bottom	0.400	0.400	0.400	0.800	0.800	1.200	N/A	N/A	N/A
	Right	0.181	0.004	1.173	0.185	1.354	1.358	N/A	N/A	N/A
	Left	0.113	1.009	0.021	1.122	0.134	1.143	N/A	N/A	N/A
Simult Tx	Configuration	LTE Band 25 (PCS) SAR (W/kg)	2.4 GHz WLAN Ant 1 SAR (W/kg)	5 GHz WLAN Ant 2 SAR (W/kg)	Σ SAR (W/kg)			SPLSR		
		1	2	3	1+2	1+3	1+2+3	1+2	1+3	2+3
Body SAR	Back	1.066	0.687	0.717	See Note 1	See Note 1	See Note 1	0.04	0.03	0.01
	Top	0.700	0.125	0.281	0.825	0.981	1.106	N/A	N/A	N/A
	Bottom	0.400	0.400	0.400	0.800	0.800	1.200	N/A	N/A	N/A
	Right	0.186	0.004	1.173	0.190	1.359	1.363	N/A	N/A	N/A
	Left	0.112	1.009	0.021	1.121	0.133	1.142	N/A	N/A	N/A

FCC ID: A3LSMT867U	 PCTEST ENGINEERING LABORATORY, INC.	SAR EVALUATION REPORT		Approved by: Quality Manager
Document S/N: 1M1907300131-01-R1.A3L	Test Dates: 08/05/19 - 08/27/19	DUT Type: Portable Tablet	Page 95 of 126	

Simult Tx	Configuration	LTE Band 7 SAR (W/kg)	2.4 GHz WLAN Ant 1 SAR (W/kg)	5 GHz WLAN Ant 2 SAR (W/kg)	Σ SAR (W/kg)			SPLSR		
		1	2	3	1+2	1+3	1+2+3	1+2	1+3	2+3
Body SAR	Back	1.133	0.687	0.717	See Note 1	See Note 1	See Note 1	0.03	0.04	0.01
	Top	1.144	0.125	0.281	1.269	1.425	1.550	N/A	N/A	N/A
	Bottom	0.400	0.400	0.400	0.800	0.800	1.200	N/A	N/A	N/A
	Right	0.347	0.004	1.173	0.351	1.520	1.524	N/A	N/A	N/A
	Left	0.356	1.009	0.021	1.365	0.377	1.386	N/A	N/A	N/A
Simult Tx	Configuration	LTE Band 41 SAR (W/kg)	2.4 GHz WLAN Ant 1 SAR (W/kg)	5 GHz WLAN Ant 2 SAR (W/kg)	Σ SAR (W/kg)			SPLSR		
		1	2	3	1+2	1+3	1+2+3	1+2	1+3	2+3
Body SAR	Back	0.697	0.687	0.717	1.384	1.414	See Note 1	0.02	0.03	0.01
	Top	0.528	0.125	0.281	0.653	0.809	0.934	N/A	N/A	N/A
	Bottom	0.400	0.400	0.400	0.800	0.800	1.200	N/A	N/A	N/A
	Right	0.268	0.004	1.173	0.272	1.441	1.445	N/A	N/A	N/A
	Left	0.475	1.009	0.021	1.484	0.496	1.505	N/A	N/A	N/A







FCC ID: A3LSMT867U	 PCTEST ENGINEERING LABORATORY, INC.	SAR EVALUATION REPORT		Approved by: Quality Manager
Document S/N: 1M1907300131-01-R1.A3L	Test Dates: 08/05/19 - 08/27/19	DUT Type: Portable Tablet		Page 96 of 126

Table 11-4
Simultaneous Transmission Scenario with Bluetooth and 5 GHz WLAN Ant 2

Simult Tx	Configuration	UMTS 850 SAR (W/kg)	Bluetooth SAR (W/kg)	5 GHz WLAN Ant 2 SAR (W/kg)	Σ SAR (W/kg)			SPLSR		
		1	2	3	1+2	1+3	1+2+3	1+2	1+3	2+3
Body SAR	Back	1.113	0.640	0.717	See Note 1	See Note 1	See Note 1	0.03	0.03	0.01
	Top	1.056	0.072	0.281	1.128	1.337	1.409	N/A	N/A	N/A
	Bottom	0.400	0.400	0.400	0.800	0.800	1.200	N/A	N/A	N/A
	Right	0.242	0.000	1.173	0.242	1.415	1.415	N/A	N/A	N/A
	Left	0.132	0.922	0.021	1.054	0.153	1.075	N/A	N/A	N/A
Simult Tx	Configuration	UMTS 1750 SAR (W/kg)	Bluetooth SAR (W/kg)	5 GHz WLAN Ant 2 SAR (W/kg)	Σ SAR (W/kg)			SPLSR		
		1	2	3	1+2	1+3	1+2+3	1+2	1+3	2+3
Body SAR	Back	1.049	0.640	0.717	See Note 1	See Note 1	See Note 1	0.03	0.03	0.01
	Top	0.751	0.072	0.281	0.823	1.032	1.104	N/A	N/A	N/A
	Bottom	0.400	0.400	0.400	0.800	0.800	1.200	N/A	N/A	N/A
	Right	0.166	0.000	1.173	0.166	1.339	1.339	N/A	N/A	N/A
	Left	0.208	0.922	0.021	1.130	0.229	1.151	N/A	N/A	N/A
Simult Tx	Configuration	UMTS 1900 SAR (W/kg)	Bluetooth SAR (W/kg)	5 GHz WLAN Ant 2 SAR (W/kg)	Σ SAR (W/kg)			SPLSR		
		1	2	3	1+2	1+3	1+2+3	1+2	1+3	2+3
Body SAR	Back	0.925	0.640	0.717	1.565	See Note 1	See Note 1	0.03	0.03	0.01
	Top	0.757	0.072	0.281	0.829	1.038	1.110	N/A	N/A	N/A
	Bottom	0.400	0.400	0.400	0.800	0.800	1.200	N/A	N/A	N/A
	Right	0.212	0.000	1.173	0.212	1.385	1.385	N/A	N/A	N/A
	Left	0.102	0.922	0.021	1.024	0.123	1.045	N/A	N/A	N/A
Simult Tx	Configuration	LTE Band 71 SAR (W/kg)	Bluetooth SAR (W/kg)	5 GHz WLAN Ant 2 SAR (W/kg)	Σ SAR (W/kg)			SPLSR		
		1	2	3	1+2	1+3	1+2+3	1+2	1+3	2+3
Body SAR	Back	0.531	0.640	0.717	1.171	1.248	See Note 1	0.02	0.02	0.01
	Top	0.693	0.072	0.281	0.765	0.974	1.046	N/A	N/A	N/A
	Bottom	0.400	0.400	0.400	0.800	0.800	1.200	N/A	N/A	N/A
	Right	0.121	0.000	1.173	0.121	1.294	1.294	N/A	N/A	N/A
	Left	0.122	0.922	0.021	1.044	0.143	1.065	N/A	N/A	N/A
Simult Tx	Configuration	LTE Band 12 SAR (W/kg)	Bluetooth SAR (W/kg)	5 GHz WLAN Ant 2 SAR (W/kg)	Σ SAR (W/kg)			SPLSR		
		1	2	3	1+2	1+3	1+2+3	1+2	1+3	2+3
Body SAR	Back	0.700	0.640	0.717	1.340	1.417	See Note 1	0.02	0.02	0.01
	Top	0.869	0.072	0.281	0.941	1.150	1.222	N/A	N/A	N/A
	Bottom	0.400	0.400	0.400	0.800	0.800	1.200	N/A	N/A	N/A
	Right	0.152	0.000	1.173	0.152	1.325	1.325	N/A	N/A	N/A
	Left	0.162	0.922	0.021	1.084	0.183	1.105	N/A	N/A	N/A

FCC ID: A3LSMT867U	 PCTEST Engineering Laboratory, Inc.	SAR EVALUATION REPORT		Approved by: Quality Manager
Document S/N: 1M1907300131-01-R1.A3L	Test Dates: 08/05/19 - 08/27/19	DUT Type: Portable Tablet		Page 97 of 126



Simult Tx	Configuration	LTE Band 13 SAR (W/kg)	Bluetooth SAR (W/kg)	5 GHz WLAN Ant 2 SAR (W/kg)	Σ SAR (W/kg)			SPLSR		
		1	2	3	1+2	1+3	1+2+3	1+2	1+3	2+3
Body SAR	Back	1.206	0.640	0.717	See Note 1	See Note 1	See Note 1	0.03	0.04	0.01
	Top	1.172	0.072	0.281	1.244	1.453	1.525	N/A	N/A	N/A
	Bottom	0.400	0.400	0.400	0.800	0.800	1.200	N/A	N/A	N/A
	Right	0.233	0.000	1.173	0.233	1.406	1.406	N/A	N/A	N/A
	Left	0.142	0.922	0.021	1.064	0.163	1.085	N/A	N/A	N/A
Simult Tx	Configuration	LTE Band 26 (Cell) SAR (W/kg)	Bluetooth SAR (W/kg)	5 GHz WLAN Ant 2 SAR (W/kg)	Σ SAR (W/kg)			SPLSR		
		1	2	3	1+2	1+3	1+2+3	1+2	1+3	2+3
Body SAR	Back	1.033	0.640	0.717	See Note 1	See Note 1	See Note 1	0.03	0.04	0.01
	Top	1.036	0.072	0.281	1.108	1.317	1.389	N/A	N/A	N/A
	Bottom	0.400	0.400	0.400	0.800	0.800	1.200	N/A	N/A	N/A
	Right	0.302	0.000	1.173	0.302	1.475	1.475	N/A	N/A	N/A
	Left	0.126	0.922	0.021	1.048	0.147	1.069	N/A	N/A	N/A
Simult Tx	Configuration	LTE Band 66 (AWS) SAR (W/kg)	Bluetooth SAR (W/kg)	5 GHz WLAN Ant 2 SAR (W/kg)	Σ SAR (W/kg)			SPLSR		
		1	2	3	1+2	1+3	1+2+3	1+2	1+3	2+3
Body SAR	Back	1.060	0.640	0.717	See Note 1	See Note 1	See Note 1	0.04	0.03	0.01
	Top	0.931	0.072	0.281	1.003	1.212	1.284	N/A	N/A	N/A
	Bottom	0.400	0.400	0.400	0.800	0.800	1.200	N/A	N/A	N/A
	Right	0.169	0.000	1.173	0.169	1.342	1.342	N/A	N/A	N/A
	Left	0.275	0.922	0.021	1.197	0.296	1.218	N/A	N/A	N/A
Simult Tx	Configuration	LTE Band 2 (PCS) SAR (W/kg)	Bluetooth SAR (W/kg)	5 GHz WLAN Ant 2 SAR (W/kg)	Σ SAR (W/kg)			SPLSR		
		1	2	3	1+2	1+3	1+2+3	1+2	1+3	2+3
Body SAR	Back	0.961	0.640	0.717	See Note 1	See Note 1	See Note 1	0.03	0.03	0.01
	Top	0.852	0.072	0.281	0.924	1.133	1.205	N/A	N/A	N/A
	Bottom	0.400	0.400	0.400	0.800	0.800	1.200	N/A	N/A	N/A
	Right	0.181	0.000	1.173	0.181	1.354	1.354	N/A	N/A	N/A
	Left	0.113	0.922	0.021	1.035	0.134	1.056	N/A	N/A	N/A
Simult Tx	Configuration	LTE Band 25 (PCS) SAR (W/kg)	Bluetooth SAR (W/kg)	5 GHz WLAN Ant 2 SAR (W/kg)	Σ SAR (W/kg)			SPLSR		
		1	2	3	1+2	1+3	1+2+3	1+2	1+3	2+3
Body SAR	Back	1.066	0.640	0.717	See Note 1	See Note 1	See Note 1	0.04	0.03	0.01
	Top	0.700	0.072	0.281	0.772	0.981	1.053	N/A	N/A	N/A
	Bottom	0.400	0.400	0.400	0.800	0.800	1.200	N/A	N/A	N/A
	Right	0.186	0.000	1.173	0.186	1.359	1.359	N/A	N/A	N/A
	Left	0.112	0.922	0.021	1.034	0.133	1.055	N/A	N/A	N/A

FCC ID: A3LSMT867U	 PCTEST ENGINEERING LABORATORY, INC.	SAR EVALUATION REPORT		Approved by: Quality Manager
Document S/N: 1M1907300131-01-R1.A3L	Test Dates: 08/05/19 - 08/27/19	DUT Type: Portable Tablet	Page 98 of 126	

Simult Tx	Configuration	LTE Band 7 SAR (W/kg)	Bluetooth SAR (W/kg)	5 GHz WLAN Ant 2 SAR (W/kg)	Σ SAR (W/kg)			SPLSR		
		1	2	3	1+2	1+3	1+2+3	1+2	1+3	2+3
Body SAR	Back	1.133	0.640	0.717	See Note 1	See Note 1	See Note 1	0.03	0.04	0.01
	Top	1.144	0.072	0.281	1.216	1.425	1.497	N/A	N/A	N/A
	Bottom	0.400	0.400	0.400	0.800	0.800	1.200	N/A	N/A	N/A
	Right	0.347	0.000	1.173	0.347	1.520	1.520	N/A	N/A	N/A
	Left	0.356	0.922	0.021	1.278	0.377	1.299	N/A	N/A	N/A
Simult Tx	Configuration	LTE Band 41 SAR (W/kg)	Bluetooth SAR (W/kg)	5 GHz WLAN Ant 2 SAR (W/kg)	Σ SAR (W/kg)			SPLSR		
		1	2	3	1+2	1+3	1+2+3	1+2	1+3	2+3
Body SAR	Back	0.697	0.640	0.717	1.337	1.414	See Note 1	0.02	0.03	0.01
	Top	0.528	0.072	0.281	0.600	0.809	0.881	N/A	N/A	N/A
	Bottom	0.400	0.400	0.400	0.800	0.800	1.200	N/A	N/A	N/A
	Right	0.268	0.000	1.173	0.268	1.441	1.441	N/A	N/A	N/A
	Left	0.475	0.922	0.021	1.397	0.496	1.418	N/A	N/A	N/A

Notes:

1. No evaluation was performed to determine the aggregate 1g SAR for these configurations as the SPSL ratio between the antenna pairs was not greater than 0.04 per FCC KDB 447498 D01v06. See Section 11.3 for detailed SPSL ratio analysis.
2. For SAR summation, the highest reported SAR across all test distances was used as the most conservative evaluation for simultaneous transmission analysis for each device edge.
3. When the antenna separation distance was > 50 mm, an estimated SAR of 0.4 W/kg was used to determine the simultaneous transmission SAR exclusion for test positions excluded per FCC KDB Publication 447498 D01v06.

FCC ID: A3LSMT867U	 PCTEST ENGINEERING LABORATORY, INC.	SAR EVALUATION REPORT	 SAMSUNG	Approved by: Quality Manager
Document S/N: 1M1907300131-01-R1.A3L	Test Dates: 08/05/19 - 08/27/19	DUT Type: Portable Tablet	Page 99 of 126	

11.3 SPLSR Evaluation and Analysis

Per FCC KDB Publication 447498 D01v06, when the sum of the standalone transmitters is more than 1.6 W/kg for 1g, the SAR sum to peak locations can be analyzed to determine SAR distribution overlaps. When the SAR peak to location ratio (shown below) for each pair of antennas is ≤ 0.04 for 1g, simultaneous SAR evaluation is not required. The distance between the transmitters was calculated using the following formula.



$$\text{Distance}_{\text{Tx1} - \text{Tx2}} = R_i = \sqrt{(x_1 - x_2)^2 + (y_1 - y_2)^2} \text{ (Body)}$$

$$\text{SPLS Ratio} = \frac{(SAR_1 + SAR_2)^{1.5}}{R_i}$$

11.3.1 Back Side SPLSR Evaluation and Analysis



**Table 11-5
Peak SAR Locations for Body Back Side**

Mode/Band	x (mm)	y (mm)
2.4 GHz WLAN Ant 1	3.00	-65.00
2.4 GHz WLAN Ant 2	10.60	79.60
2.4 GHz Bluetooth	3.00	-74.00
5 GHz WLAN Ant 1	8.00	-77.00
5 GHz WLAN Ant 2	7.00	73.00
UMTS 850	12.00	-6.00
UMTS 1750	17.00	-8.00
UMTS 1900	15.50	-6.50
LTE Band 71	2.00	-14.50
LTE Band 12	8.00	5.50
LTE Band 13	3.50	1.50
LTE Band 26 (Cell)	21.50	10.00
LTE Band 66 (AWS)	10.00	-13.50
LTE Band 2 (PCS)	8.50	-12.00
LTE Band 25 (PCS)	8.50	-13.50
LTE Band 7	7.40	16.00
LTE Band 41	6.10	22.40

FCC ID: A3LSMT867U	 PCTEST ENGINEERING LABORATORY, INC.	SAR EVALUATION REPORT		Approved by: Quality Manager
Document S/N: 1M1907300131-01-R1.A3L	Test Dates: 08/05/19 - 08/27/19	DUT Type: Portable Tablet	Page 100 of 126	



**Table 11-6
Back Side SAR to Peak Location Separation Ratio Calculations**

Antenna Pair		Standalone SAR (W/kg)		Standalone SAR Sum (W/kg)	Peak SAR Separation Distance (mm)	SPLS Ratio	Plot Number
Ant "a"	Ant "b"	a	b	a+b	D _{a-b}	$(a+b)^{1.5}/D_{a-b}$	
UMTS 850	2.4 GHz WLAN Ant 1	1.113	0.687	1.8	59.68	0.04	1, 25
UMTS 1750	2.4 GHz WLAN Ant 1	1.049	0.687	1.736	58.69	0.04	2, 26
UMTS 1900	2.4 GHz WLAN Ant 1	0.925	0.687	1.612	59.82	0.03	3, 27
LTE Band 13	2.4 GHz WLAN Ant 1	1.206	0.687	1.893	66.50	0.04	6, 30
LTE Band 26 (Cell)	2.4 GHz WLAN Ant 1	1.033	0.687	1.72	77.25	0.03	7, 31
LTE Band 66 (AWS)	2.4 GHz WLAN Ant 1	1.060	0.687	1.747	51.97	0.04	8, 32
LTE Band 2 (PCS)	2.4 GHz WLAN Ant 1	0.961	0.687	1.648	53.28	0.04	9, 33
LTE Band 25 (PCS)	2.4 GHz WLAN Ant 1	1.066	0.687	1.753	51.79	0.04	10, 34
LTE Band 7	2.4 GHz WLAN Ant 1	1.133	0.687	1.82	81.12	0.03	11, 35
UMTS 850	2.4 GHz WLAN Ant 2	1.113	0.798	1.911	85.61	0.03	1
UMTS 1750	2.4 GHz WLAN Ant 2	1.049	0.798	1.847	87.83	0.03	2
UMTS 1900	2.4 GHz WLAN Ant 2	0.925	0.798	1.723	86.24	0.03	3
LTE Band 13	2.4 GHz WLAN Ant 2	1.206	0.798	2.004	78.42	0.04	6
LTE Band 26 (Cell)	2.4 GHz WLAN Ant 2	1.033	0.798	1.831	70.45	0.04	7
LTE Band 66 (AWS)	2.4 GHz WLAN Ant 2	1.060	0.798	1.858	93.10	0.03	8
LTE Band 2 (PCS)	2.4 GHz WLAN Ant 2	0.961	0.798	1.759	91.62	0.03	9
LTE Band 25 (PCS)	2.4 GHz WLAN Ant 2	1.066	0.798	1.864	93.12	0.03	10
LTE Band 7	2.4 GHz WLAN Ant 2	1.133	0.798	1.931	63.68	0.04	11
UMTS 850	5 GHz WLAN Ant 2	1.113	0.717	1.83	79.16	0.03	13, 25
UMTS 1750	5 GHz WLAN Ant 2	1.049	0.717	1.766	81.61	0.03	14, 26
UMTS 1900	5 GHz WLAN Ant 2	0.925	0.717	1.642	79.95	0.03	15, 27
LTE Band 13	5 GHz WLAN Ant 2	1.206	0.717	1.923	71.59	0.04	18, 30
LTE Band 26 (Cell)	5 GHz WLAN Ant 2	1.033	0.717	1.75	64.65	0.04	19, 31
LTE Band 66 (AWS)	5 GHz WLAN Ant 2	1.060	0.717	1.777	86.55	0.03	20, 32
LTE Band 2 (PCS)	5 GHz WLAN Ant 2	0.961	0.717	1.678	85.01	0.03	21, 33
LTE Band 25 (PCS)	5 GHz WLAN Ant 2	1.066	0.717	1.783	86.51	0.03	22, 34
LTE Band 7	5 GHz WLAN Ant 2	1.133	0.717	1.85	57.00	0.04	23, 35
UMTS 850	2.4 GHz Bluetooth	1.113	0.640	1.753	68.59	0.03	37
UMTS 1750	2.4 GHz Bluetooth	1.049	0.640	1.689	67.47	0.03	38
LTE Band 13	2.4 GHz Bluetooth	1.206	0.640	1.846	75.50	0.03	42
LTE Band 26 (Cell)	2.4 GHz Bluetooth	1.033	0.640	1.673	86.01	0.03	43
LTE Band 66 (AWS)	2.4 GHz Bluetooth	1.060	0.640	1.7	60.90	0.04	44
LTE Band 2 (PCS)	2.4 GHz Bluetooth	0.961	0.640	1.601	62.24	0.03	45
LTE Band 25 (PCS)	2.4 GHz Bluetooth	1.066	0.640	1.706	60.75	0.04	46
LTE Band 7	2.4 GHz Bluetooth	1.133	0.640	1.773	90.11	0.03	47

FCC ID: A3LSMT867U	 PCTEST ENGINEERING LABORATORY, INC.	SAR EVALUATION REPORT		Approved by: Quality Manager
Document S/N: 1M1907300131-01-R1.A3L	Test Dates: 08/05/19 - 08/27/19	DUT Type: Portable Tablet	Page 101 of 126	



**Table 11-7
Back Side SAR to Peak Location Separation Ratio Calculations Cont.**

Antenna Pair		Standalone SAR (W/kg)		Standalone SAR Sum (W/kg)	Peak SAR Separation Distance (mm)	SPLS Ratio	Plot Number
Ant "a"	Ant "b"	a	b	a+b	D _{a-b}	$(a+b)^{1.5}/D_{a-b}$	
2.4 GHz WLAN Ant 1	2.4 GHz WLAN Ant 2	0.687	0.798	1.485	144.80	0.01	1
2.4 GHz WLAN Ant 1	UMTS 850	0.687	1.113	1.8	59.68	0.04	
2.4 GHz WLAN Ant 2	UMTS 850	0.798	1.113	1.911	85.61	0.03	
2.4 GHz WLAN Ant 1	2.4 GHz WLAN Ant 2	0.687	0.798	1.485	144.80	0.01	2
2.4 GHz WLAN Ant 1	UMTS 1750	0.687	1.049	1.736	58.69	0.04	
2.4 GHz WLAN Ant 2	UMTS 1750	0.798	1.049	1.847	87.83	0.03	
2.4 GHz WLAN Ant 1	2.4 GHz WLAN Ant 2	0.687	0.798	1.485	144.80	0.01	3
2.4 GHz WLAN Ant 1	UMTS 1900	0.687	0.925	1.612	59.82	0.03	
2.4 GHz WLAN Ant 2	UMTS 1900	0.798	0.925	1.723	86.24	0.03	
2.4 GHz WLAN Ant 1	2.4 GHz WLAN Ant 2	0.687	0.798	1.485	144.80	0.01	4
2.4 GHz WLAN Ant 1	LTE Band 71	0.687	0.531	1.218	50.51	0.03	
2.4 GHz WLAN Ant 2	LTE Band 71	0.798	0.531	1.329	94.49	0.02	
2.4 GHz WLAN Ant 1	2.4 GHz WLAN Ant 2	0.687	0.798	1.485	144.80	0.01	5
2.4 GHz WLAN Ant 1	LTE Band 12	0.687	0.700	1.387	70.68	0.02	
2.4 GHz WLAN Ant 2	LTE Band 12	0.798	0.700	1.498	74.15	0.02	
2.4 GHz WLAN Ant 1	2.4 GHz WLAN Ant 2	0.687	0.798	1.485	144.80	0.01	6
2.4 GHz WLAN Ant 1	LTE Band 13	0.687	1.206	1.893	66.50	0.04	
2.4 GHz WLAN Ant 2	LTE Band 13	0.798	1.206	2.004	78.42	0.04	
2.4 GHz WLAN Ant 1	2.4 GHz WLAN Ant 2	0.687	0.798	1.485	144.80	0.01	7
2.4 GHz WLAN Ant 1	LTE Band 26 (Cell)	0.687	1.033	1.72	77.25	0.03	
2.4 GHz WLAN Ant 2	LTE Band 26 (Cell)	0.798	1.033	1.831	70.45	0.04	
2.4 GHz WLAN Ant 1	2.4 GHz WLAN Ant 2	0.687	0.798	1.485	144.80	0.01	8
2.4 GHz WLAN Ant 1	LTE Band 66 (AWS)	0.687	1.060	1.747	51.97	0.04	
2.4 GHz WLAN Ant 2	LTE Band 66 (AWS)	0.798	1.060	1.858	93.10	0.03	
2.4 GHz WLAN Ant 1	2.4 GHz WLAN Ant 2	0.687	0.798	1.485	144.80	0.01	9
2.4 GHz WLAN Ant 1	LTE Band 2 (PCS)	0.687	0.961	1.648	53.28	0.04	
2.4 GHz WLAN Ant 2	LTE Band 2 (PCS)	0.798	0.961	1.759	91.62	0.03	
2.4 GHz WLAN Ant 1	2.4 GHz WLAN Ant 2	0.687	0.798	1.485	144.80	0.01	10
2.4 GHz WLAN Ant 1	LTE Band 25 (PCS)	0.687	1.066	1.753	51.79	0.04	
2.4 GHz WLAN Ant 2	LTE Band 25 (PCS)	0.798	1.066	1.864	93.12	0.03	
2.4 GHz WLAN Ant 1	2.4 GHz WLAN Ant 2	0.687	0.798	1.485	144.80	0.01	11
2.4 GHz WLAN Ant 1	LTE Band 7	0.687	1.133	1.82	81.12	0.03	
2.4 GHz WLAN Ant 2	LTE Band 7	0.798	1.133	1.931	63.68	0.04	
2.4 GHz WLAN Ant 1	2.4 GHz WLAN Ant 2	0.687	0.798	1.485	144.80	0.01	12
2.4 GHz WLAN Ant 1	LTE Band 41	0.687	0.697	1.384	87.45	0.02	
2.4 GHz WLAN Ant 2	LTE Band 41	0.798	0.697	1.495	57.38	0.03	

FCC ID: A3LSMT867U		SAR EVALUATION REPORT		Approved by: Quality Manager
Document S/N: 1M1907300131-01-R1.A3L	Test Dates: 08/05/19 - 08/27/19	DUT Type: Portable Tablet	Page 102 of 126	



**Table 11-8
Back Side SAR to Peak Location Separation Ratio Calculations Cont.**

Antenna Pair		Standalone SAR (W/kg)		Standalone SAR Sum (W/kg)	Peak SAR Separation Distance (mm)	SPLS Ratio	Plot Number
Ant "a"	Ant "b"	a	b	a+b	D _{a-b}	$(a+b)^{1.5}/D_{a-b}$	
5 GHz WLAN Ant 1	5 GHz WLAN Ant 2	0.386	0.717	1.103	150.00	0.01	13
5 GHz WLAN Ant 1	UMTS 850	0.386	1.113	1.499	71.11	0.03	
5 GHz WLAN Ant 2	UMTS 850	0.717	1.113	1.83	79.16	0.03	
5 GHz WLAN Ant 1	5 GHz WLAN Ant 2	0.386	0.717	1.103	150.00	0.01	14
5 GHz WLAN Ant 1	UMTS 1750	0.386	1.049	1.435	69.58	0.02	
5 GHz WLAN Ant 2	UMTS 1750	0.717	1.049	1.766	81.61	0.03	
5 GHz WLAN Ant 1	5 GHz WLAN Ant 2	0.386	0.717	1.103	150.00	0.01	15
5 GHz WLAN Ant 1	UMTS 1900	0.386	0.925	1.311	70.90	0.02	
5 GHz WLAN Ant 2	UMTS 1900	0.717	0.925	1.642	79.95	0.03	
5 GHz WLAN Ant 1	5 GHz WLAN Ant 2	0.386	0.717	1.103	150.00	0.01	16
5 GHz WLAN Ant 1	LTE Band 71	0.386	0.531	0.917	62.79	0.01	
5 GHz WLAN Ant 2	LTE Band 71	0.717	0.531	1.248	87.64	0.02	
5 GHz WLAN Ant 1	5 GHz WLAN Ant 2	0.386	0.717	1.103	150.00	0.01	17
5 GHz WLAN Ant 1	LTE Band 12	0.386	0.700	1.086	82.50	0.01	
5 GHz WLAN Ant 2	LTE Band 12	0.717	0.700	1.417	67.51	0.02	
5 GHz WLAN Ant 1	5 GHz WLAN Ant 2	0.386	0.717	1.103	150.00	0.01	18
5 GHz WLAN Ant 1	LTE Band 13	0.386	1.206	1.592	78.63	0.03	
5 GHz WLAN Ant 2	LTE Band 13	0.717	1.206	1.923	71.59	0.04	
5 GHz WLAN Ant 1	5 GHz WLAN Ant 2	0.386	0.717	1.103	150.00	0.01	19
5 GHz WLAN Ant 1	LTE Band 26 (Cell)	0.386	1.033	1.419	88.04	0.02	
5 GHz WLAN Ant 2	LTE Band 26 (Cell)	0.717	1.033	1.75	64.65	0.04	
5 GHz WLAN Ant 1	5 GHz WLAN Ant 2	0.386	0.717	1.103	150.00	0.01	20
5 GHz WLAN Ant 1	LTE Band 66 (AWS)	0.386	1.060	1.446	63.53	0.03	
5 GHz WLAN Ant 2	LTE Band 66 (AWS)	0.717	1.060	1.777	86.55	0.03	
5 GHz WLAN Ant 1	5 GHz WLAN Ant 2	0.386	0.717	1.103	150.00	0.01	21
5 GHz WLAN Ant 1	LTE Band 2 (PCS)	0.386	0.961	1.347	65.00	0.02	
5 GHz WLAN Ant 2	LTE Band 2 (PCS)	0.717	0.961	1.678	85.01	0.03	
5 GHz WLAN Ant 1	5 GHz WLAN Ant 2	0.386	0.717	1.103	150.00	0.01	22
5 GHz WLAN Ant 1	LTE Band 25 (PCS)	0.386	1.066	1.452	63.50	0.03	
5 GHz WLAN Ant 2	LTE Band 25 (PCS)	0.717	1.066	1.783	86.51	0.03	
5 GHz WLAN Ant 1	5 GHz WLAN Ant 2	0.386	0.717	1.103	150.00	0.01	23
5 GHz WLAN Ant 1	LTE Band 7	0.386	1.133	1.519	93.00	0.02	
5 GHz WLAN Ant 2	LTE Band 7	0.717	1.133	1.85	57.00	0.04	
5 GHz WLAN Ant 1	5 GHz WLAN Ant 2	0.386	0.717	1.103	150.00	0.01	24
5 GHz WLAN Ant 1	LTE Band 41	0.386	0.697	1.083	99.42	0.01	
5 GHz WLAN Ant 2	LTE Band 41	0.717	0.697	1.414	50.61	0.03	

FCC ID: A3LSMT867U		SAR EVALUATION REPORT		Approved by: Quality Manager
Document S/N: 1M1907300131-01-R1.A3L	Test Dates: 08/05/19 - 08/27/19	DUT Type: Portable Tablet	Page 103 of 126	



**Table 11-9
Back Side SAR to Peak Location Separation Ratio Calculations Cont.**

Antenna Pair		Standalone SAR (W/kg)		Standalone SAR Sum (W/kg)	Peak SAR Separation Distance (mm)	SPLS Ratio	Plot Number
Ant "a"	Ant "b"	a	b	a+b	D _{a-b}	$(a+b)^{1.5}/D_{a-b}$	
2.4 GHz WLAN Ant 1	5 GHz WLAN Ant 2	0.687	0.717	1.404	138.06	0.01	25
2.4 GHz WLAN Ant 1	UMTS 850	0.687	1.113	1.8	59.68	0.04	
5 GHz WLAN Ant 2	UMTS 850	0.717	1.113	1.83	79.16	0.03	
2.4 GHz WLAN Ant 1	5 GHz WLAN Ant 2	0.687	0.717	1.404	138.06	0.01	26
2.4 GHz WLAN Ant 1	UMTS 1750	0.687	1.049	1.736	58.69	0.04	
5 GHz WLAN Ant 2	UMTS 1750	0.717	1.049	1.766	81.61	0.03	
2.4 GHz WLAN Ant 1	5 GHz WLAN Ant 2	0.687	0.717	1.404	138.06	0.01	27
2.4 GHz WLAN Ant 1	UMTS 1900	0.687	0.925	1.612	59.82	0.03	
5 GHz WLAN Ant 2	UMTS 1900	0.717	0.925	1.642	79.95	0.03	
2.4 GHz WLAN Ant 1	5 GHz WLAN Ant 2	0.687	0.717	1.404	138.06	0.01	28
2.4 GHz WLAN Ant 1	LTE Band 71	0.687	0.531	1.218	50.51	0.03	
5 GHz WLAN Ant 2	LTE Band 71	0.717	0.531	1.248	87.64	0.02	
2.4 GHz WLAN Ant 1	5 GHz WLAN Ant 2	0.687	0.717	1.404	138.06	0.01	29
2.4 GHz WLAN Ant 1	LTE Band 12	0.687	0.700	1.387	70.68	0.02	
5 GHz WLAN Ant 2	LTE Band 12	0.717	0.700	1.417	67.51	0.02	
2.4 GHz WLAN Ant 1	5 GHz WLAN Ant 2	0.687	0.717	1.404	138.06	0.01	30
2.4 GHz WLAN Ant 1	LTE Band 13	0.687	1.206	1.893	66.50	0.04	
5 GHz WLAN Ant 2	LTE Band 13	0.717	1.206	1.923	71.59	0.04	
2.4 GHz WLAN Ant 1	5 GHz WLAN Ant 2	0.687	0.717	1.404	138.06	0.01	31
2.4 GHz WLAN Ant 1	LTE Band 26 (Cell)	0.687	1.033	1.72	77.25	0.03	
5 GHz WLAN Ant 2	LTE Band 26 (Cell)	0.717	1.033	1.75	64.65	0.04	
2.4 GHz WLAN Ant 1	5 GHz WLAN Ant 2	0.687	0.717	1.404	138.06	0.01	32
2.4 GHz WLAN Ant 1	LTE Band 66 (AWS)	0.687	1.060	1.747	51.97	0.04	
5 GHz WLAN Ant 2	LTE Band 66 (AWS)	0.717	1.060	1.777	86.55	0.03	
2.4 GHz WLAN Ant 1	5 GHz WLAN Ant 2	0.687	0.717	1.404	138.06	0.01	33
2.4 GHz WLAN Ant 1	LTE Band 2 (PCS)	0.687	0.961	1.648	53.28	0.04	
5 GHz WLAN Ant 2	LTE Band 2 (PCS)	0.717	0.961	1.678	85.01	0.03	
2.4 GHz WLAN Ant 1	5 GHz WLAN Ant 2	0.687	0.717	1.404	138.06	0.01	34
2.4 GHz WLAN Ant 1	LTE Band 25 (PCS)	0.687	1.066	1.753	51.79	0.04	
5 GHz WLAN Ant 2	LTE Band 25 (PCS)	0.717	1.066	1.783	86.51	0.03	
2.4 GHz WLAN Ant 1	5 GHz WLAN Ant 2	0.687	0.717	1.404	138.06	0.01	35
2.4 GHz WLAN Ant 1	LTE Band 7	0.687	1.133	1.82	81.12	0.03	
5 GHz WLAN Ant 2	LTE Band 7	0.717	1.133	1.85	57.00	0.04	
2.4 GHz WLAN Ant 1	5 GHz WLAN Ant 2	0.687	0.717	1.404	138.06	0.01	36
2.4 GHz WLAN Ant 1	LTE Band 41	0.687	0.697	1.384	87.45	0.02	
5 GHz WLAN Ant 2	LTE Band 41	0.717	0.697	1.414	50.61	0.03	

FCC ID: A3LSMT867U	 PCTEST ENGINEERING LABORATORY, INC.	SAR EVALUATION REPORT		Approved by: Quality Manager
Document S/N: 1M1907300131-01-R1.A3L	Test Dates: 08/05/19 - 08/27/19	DUT Type: Portable Tablet	Page 104 of 126	



**Table 11-10
Back Side SAR to Peak Location Separation Ratio Calculations Cont.**

Antenna Pair		Standalone SAR (W/kg)		Standalone SAR Sum (W/kg)	Peak SAR Separation Distance (mm)	SPLS Ratio	Plot Number
Ant "a"	Ant "b"	a	b	a+b	D _{a-b}	$(a+b)^{1.5}/D_{a-b}$	
2.4 GHz Bluetooth	5 GHz WLAN Ant 2	0.640	0.717	1.357	147.05	0.01	37
2.4 GHz Bluetooth	UMTS 850	0.640	1.113	1.753	68.59	0.03	
5 GHz WLAN Ant 2	UMTS 850	0.717	1.113	1.83	79.16	0.03	
2.4 GHz Bluetooth	5 GHz WLAN Ant 2	0.640	0.717	1.357	147.05	0.01	38
2.4 GHz Bluetooth	UMTS 1750	0.640	1.049	1.689	67.47	0.03	
5 GHz WLAN Ant 2	UMTS 1750	0.717	1.049	1.766	81.61	0.03	
2.4 GHz Bluetooth	5 GHz WLAN Ant 2	0.640	0.717	1.357	147.05	0.01	39
2.4 GHz Bluetooth	UMTS 1900	0.640	0.925	1.565	68.65	0.03	
5 GHz WLAN Ant 2	UMTS 1900	0.717	0.925	1.642	79.95	0.03	
2.4 GHz Bluetooth	5 GHz WLAN Ant 2	0.640	0.717	1.357	147.05	0.01	40
2.4 GHz Bluetooth	LTE Band 71	0.640	0.531	1.171	59.51	0.02	
5 GHz WLAN Ant 2	LTE Band 71	0.717	0.531	1.248	87.64	0.02	
2.4 GHz Bluetooth	5 GHz WLAN Ant 2	0.640	0.717	1.357	147.05	0.01	41
2.4 GHz Bluetooth	LTE Band 12	0.640	0.700	1.34	79.66	0.02	
5 GHz WLAN Ant 2	LTE Band 12	0.717	0.700	1.417	67.51	0.02	
2.4 GHz Bluetooth	5 GHz WLAN Ant 2	0.640	0.717	1.357	147.05	0.01	42
2.4 GHz Bluetooth	LTE Band 13	0.640	1.206	1.846	75.50	0.03	
5 GHz WLAN Ant 2	LTE Band 13	0.717	1.206	1.923	71.59	0.04	
2.4 GHz Bluetooth	5 GHz WLAN Ant 2	0.640	0.717	1.357	147.05	0.01	43
2.4 GHz Bluetooth	LTE Band 26 (Cell)	0.640	1.033	1.673	86.01	0.03	
5 GHz WLAN Ant 2	LTE Band 26 (Cell)	0.717	1.033	1.75	64.65	0.04	
2.4 GHz Bluetooth	5 GHz WLAN Ant 2	0.640	0.717	1.357	147.05	0.01	44
2.4 GHz Bluetooth	LTE Band 66 (AWS)	0.640	1.060	1.7	60.90	0.04	
5 GHz WLAN Ant 2	LTE Band 66 (AWS)	0.717	1.060	1.777	86.55	0.03	
2.4 GHz Bluetooth	5 GHz WLAN Ant 2	0.640	0.717	1.357	147.05	0.01	45
2.4 GHz Bluetooth	LTE Band 2 (PCS)	0.640	0.961	1.601	62.24	0.03	
5 GHz WLAN Ant 2	LTE Band 2 (PCS)	0.717	0.961	1.678	85.01	0.03	
2.4 GHz Bluetooth	5 GHz WLAN Ant 2	0.640	0.717	1.357	147.05	0.01	46
2.4 GHz Bluetooth	LTE Band 25 (PCS)	0.640	1.066	1.706	60.75	0.04	
5 GHz WLAN Ant 2	LTE Band 25 (PCS)	0.717	1.066	1.783	86.51	0.03	
2.4 GHz Bluetooth	5 GHz WLAN Ant 2	0.640	0.717	1.357	147.05	0.01	47
2.4 GHz Bluetooth	LTE Band 7	0.640	1.133	1.773	90.11	0.03	
5 GHz WLAN Ant 2	LTE Band 7	0.717	1.133	1.85	57.00	0.04	
2.4 GHz Bluetooth	5 GHz WLAN Ant 2	0.640	0.717	1.357	147.05	0.01	48
2.4 GHz Bluetooth	LTE Band 41	0.640	0.697	1.337	96.45	0.02	
5 GHz WLAN Ant 2	LTE Band 41	0.717	0.697	1.414	50.61	0.03	

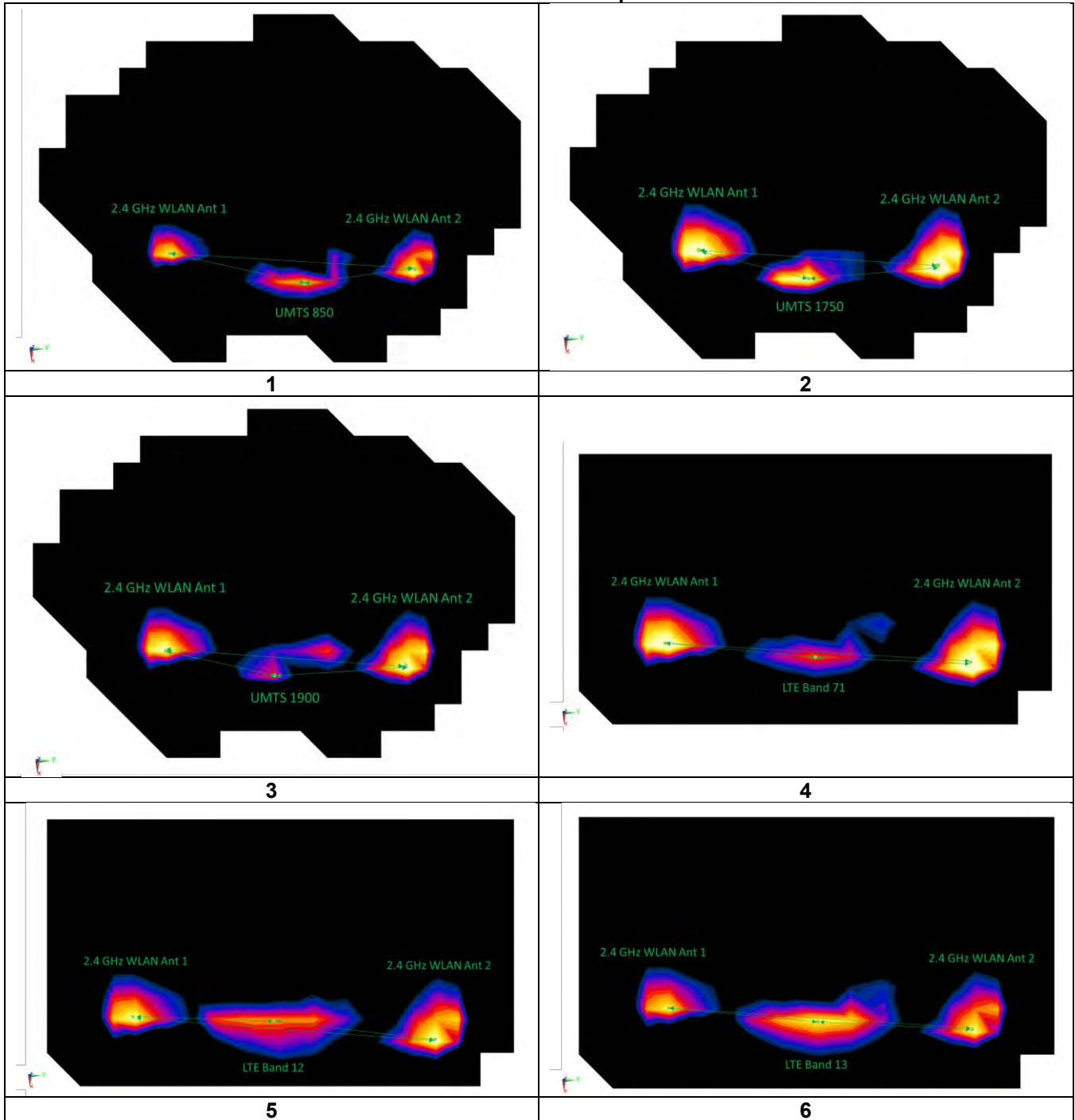

FCC ID: A3LSMT867U		SAR EVALUATION REPORT		Approved by: Quality Manager
Document S/N: 1M1907300131-01-R1.A3L	Test Dates: 08/05/19 - 08/27/19	DUT Type: Portable Tablet	Page 105 of 126	

**Table 11-11
Back Side SAR to Peak Location Separation Ratio Plots**



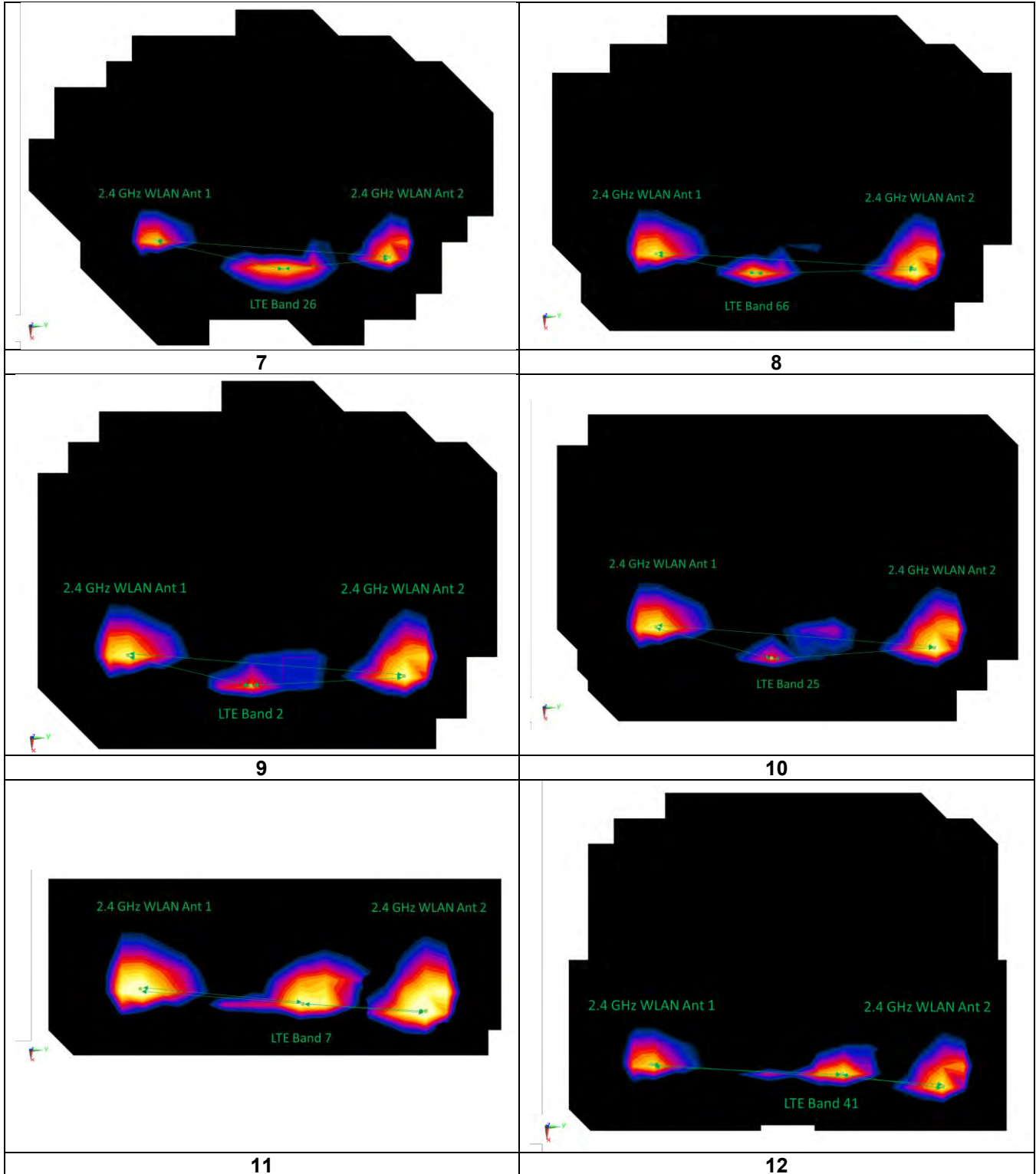

FCC ID: A3LSMT867U		SAR EVALUATION REPORT		Approved by: Quality Manager
Document S/N: 1M1907300131-01-R1.A3L	Test Dates: 08/05/19 - 08/27/19	DUT Type: Portable Tablet		Page 106 of 126



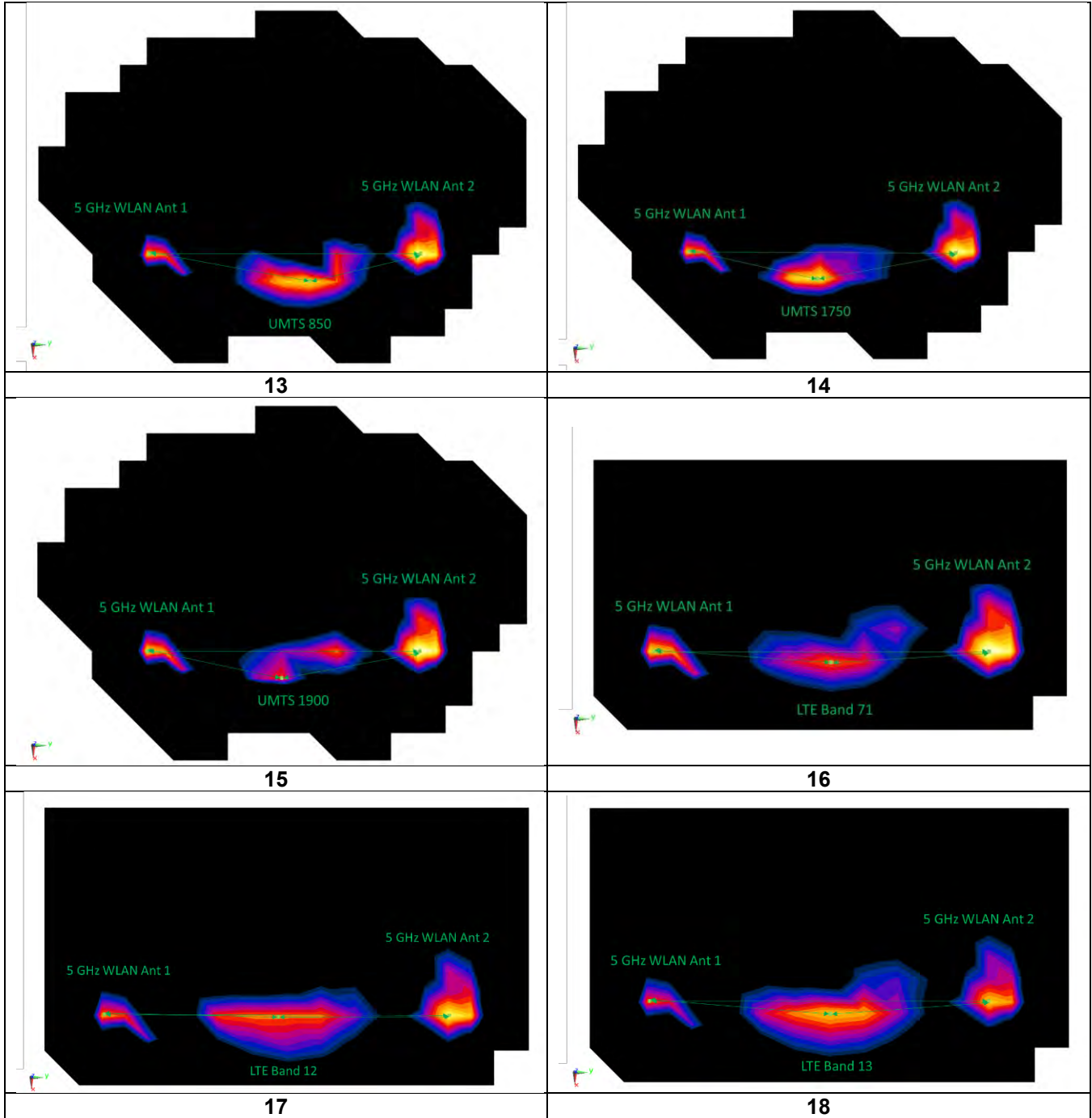

FCC ID: A3LSMT867U	 PCTEST ENGINEERING LABORATORY, INC.	SAR EVALUATION REPORT	 SAMSUNG	Approved by: Quality Manager
Document S/N: 1M1907300131-01-R1.A3L	Test Dates: 08/05/19 - 08/27/19	DUT Type: Portable Tablet		Page 107 of 126



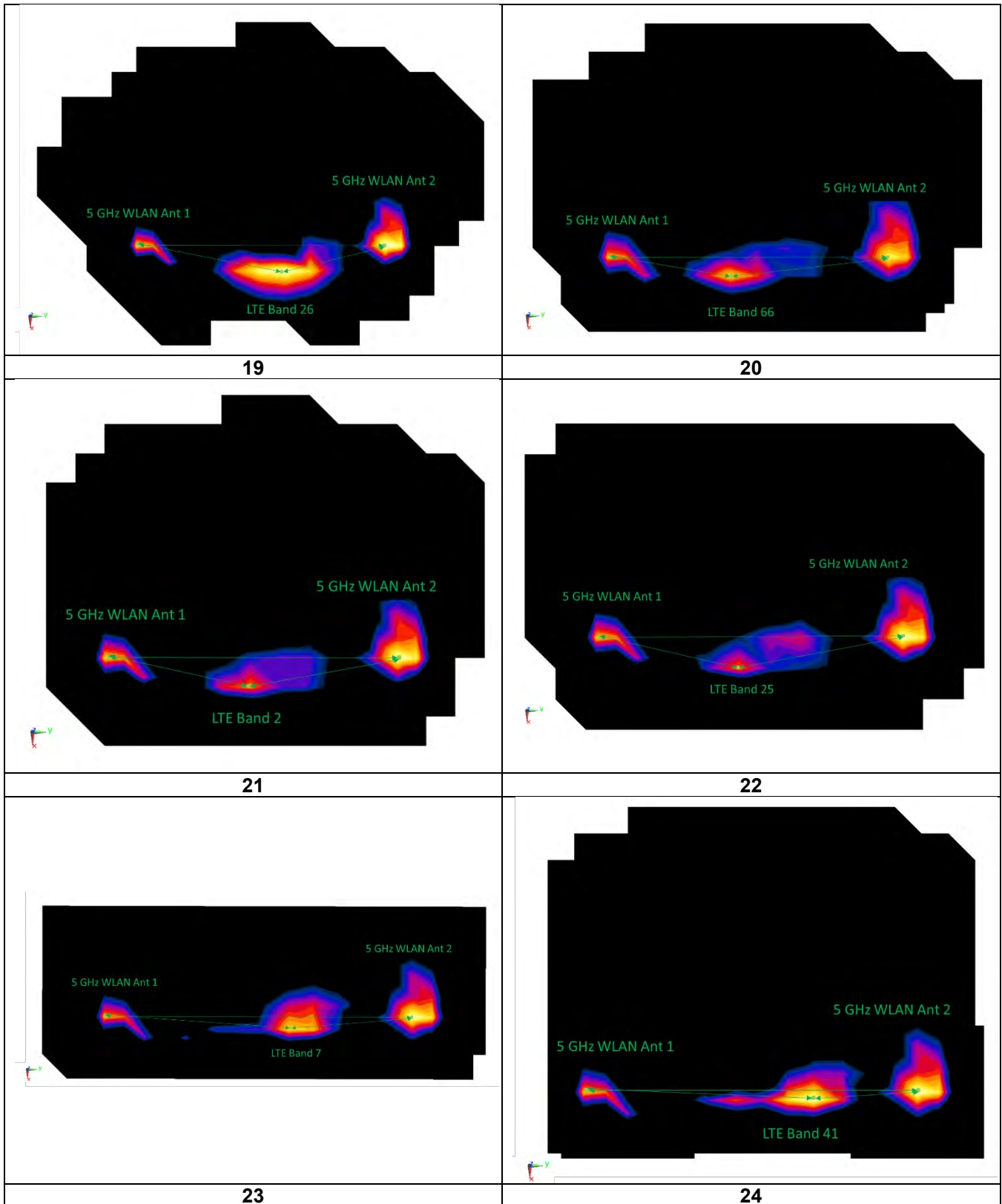

FCC ID: A3LSMT867U		SAR EVALUATION REPORT		Approved by: Quality Manager
Document S/N: 1M1907300131-01-R1.A3L	Test Dates: 08/05/19 - 08/27/19	DUT Type: Portable Tablet		Page 108 of 126



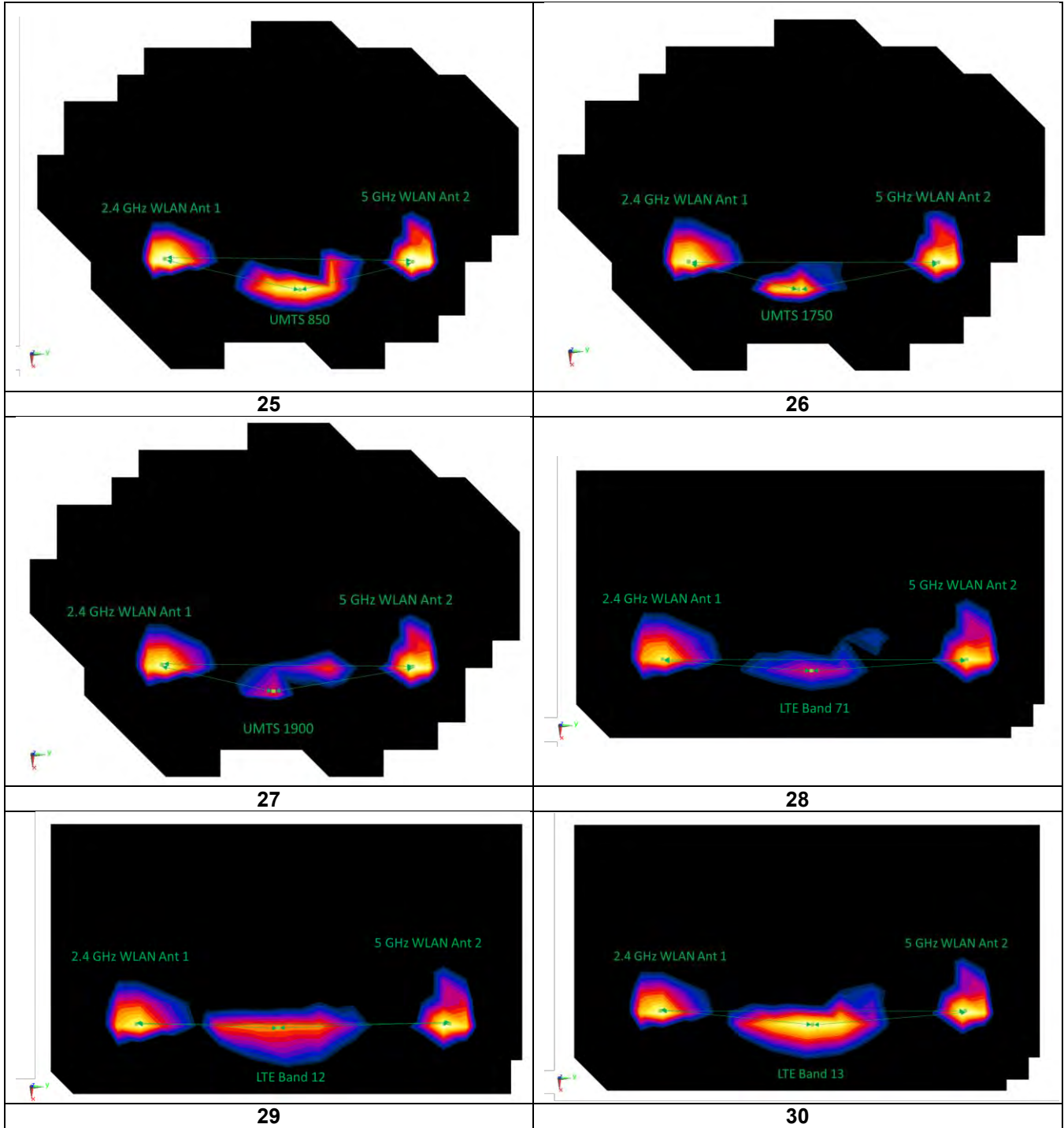

FCC ID: A3LSMT867U	 PCTEST ENGINEERING LABORATORY, INC.	SAR EVALUATION REPORT	 SAMSUNG	Approved by: Quality Manager
Document S/N: 1M1907300131-01-R1.A3L	Test Dates: 08/05/19 - 08/27/19	DUT Type: Portable Tablet		Page 109 of 126



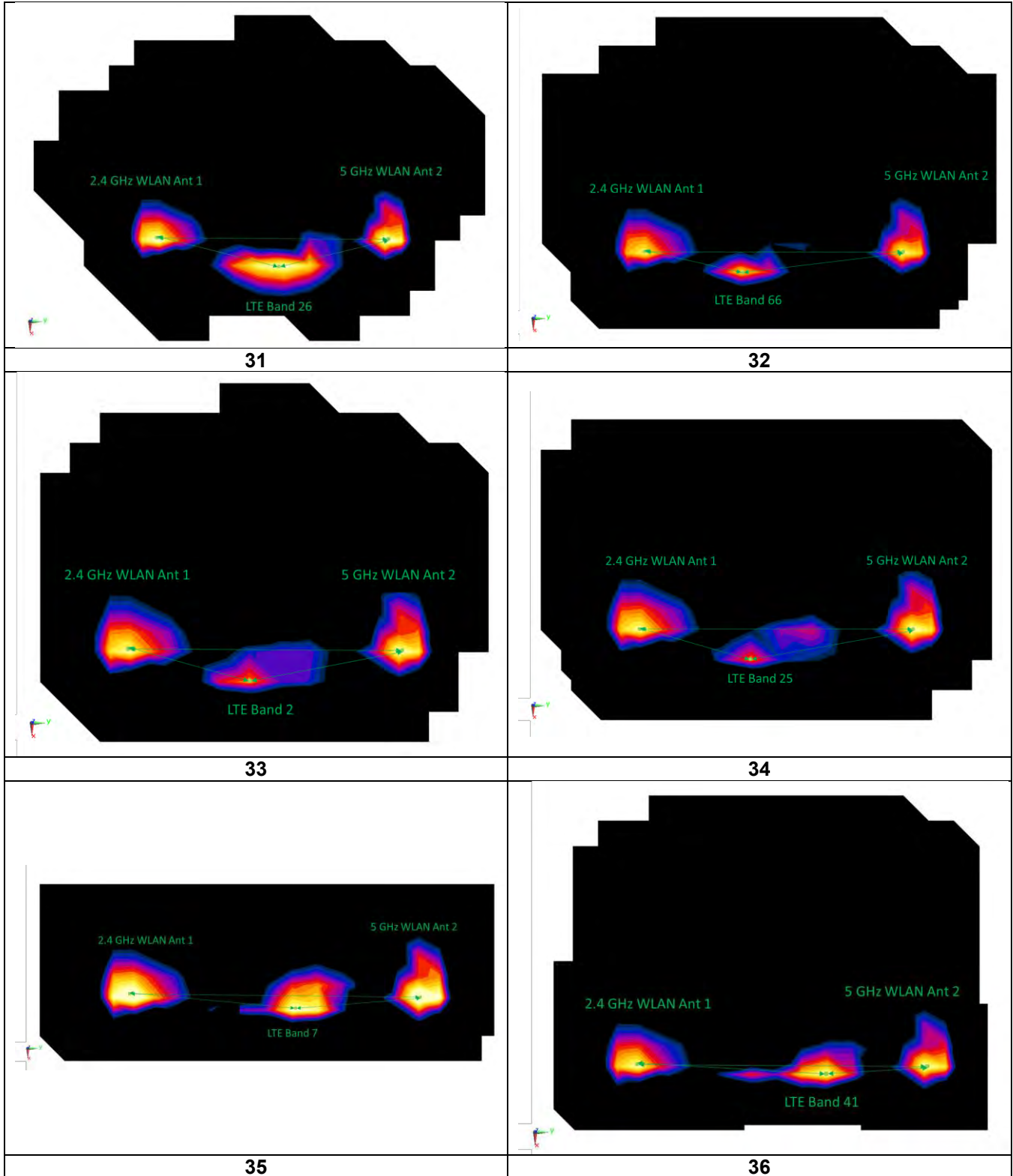

FCC ID: A3LSMT867U	 PCTEST ENGINEERING LABORATORY, INC.	SAR EVALUATION REPORT	 SAMSUNG	Approved by: Quality Manager
Document S/N: 1M1907300131-01-R1.A3L	Test Dates: 08/05/19 - 08/27/19	DUT Type: Portable Tablet	Page 110 of 126	



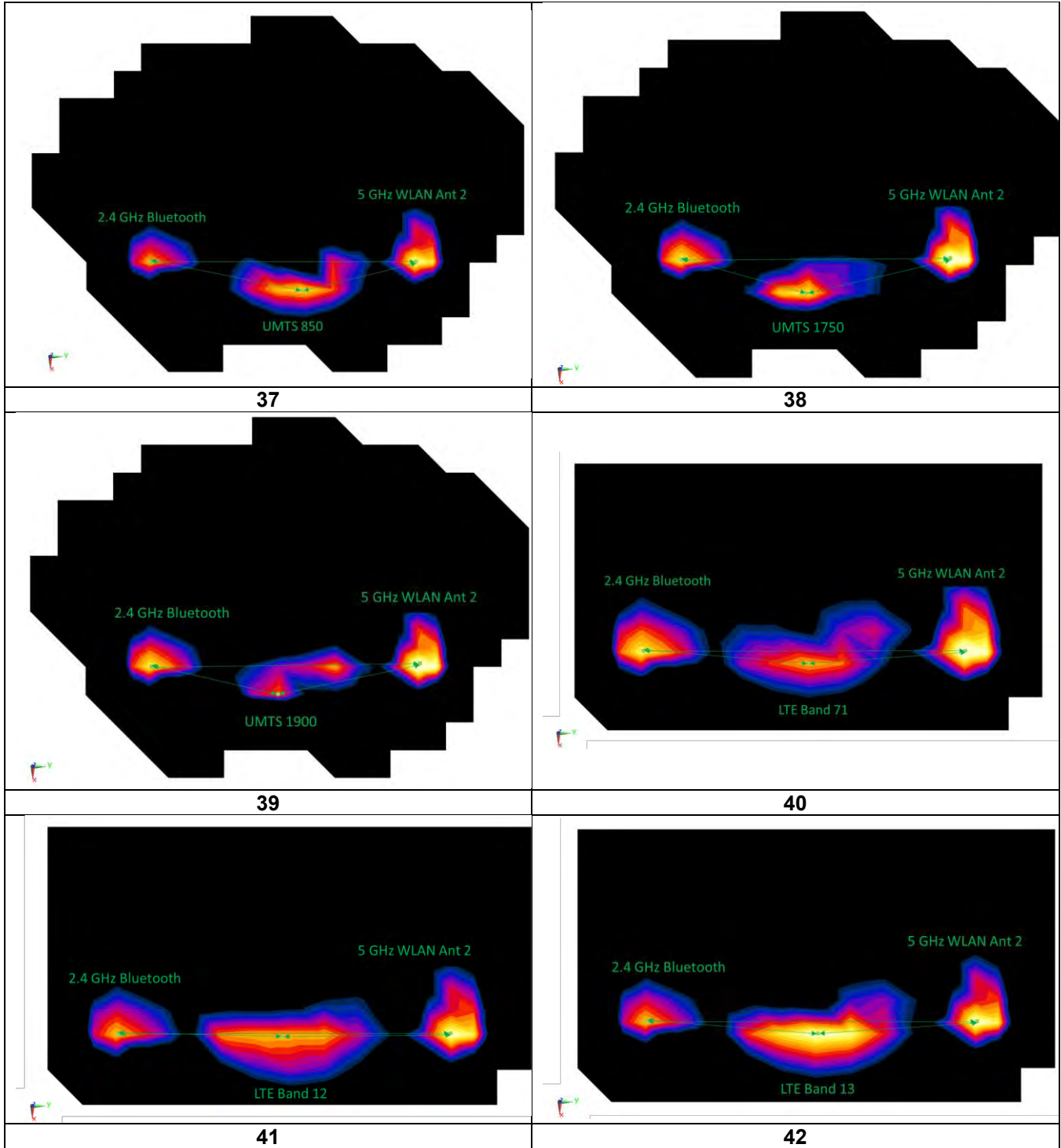

FCC ID: A3LSMT867U	 PCTEST ENGINEERING LABORATORY, INC.	SAR EVALUATION REPORT	 SAMSUNG	Approved by: Quality Manager
Document S/N: 1M1907300131-01-R1.A3L	Test Dates: 08/05/19 - 08/27/19	DUT Type: Portable Tablet		Page 111 of 126

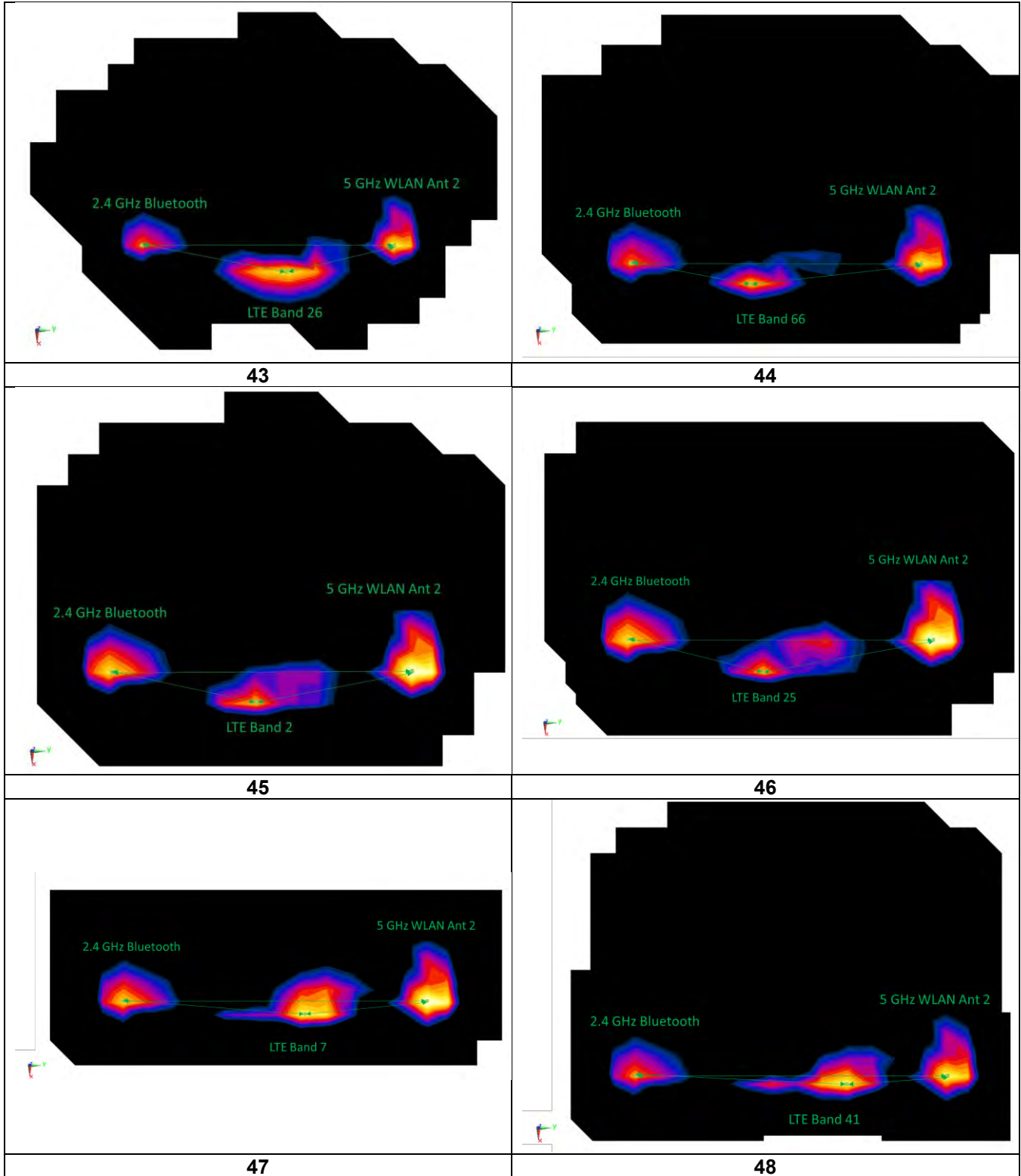

FCC ID: A3LSMT867U	 PCTEST ENGINEERING LABORATORY, INC.	SAR EVALUATION REPORT	 SAMSUNG	Approved by: Quality Manager
Document S/N: 1M1907300131-01-R1.A3L	Test Dates: 08/05/19 - 08/27/19	DUT Type: Portable Tablet		Page 112 of 126



FCC ID: A3LSMT867U	 PCTEST ENGINEERING LABORATORY, INC.	SAR EVALUATION REPORT		Approved by: Quality Manager
Document S/N: 1M1907300131-01-R1.A3L	Test Dates: 08/05/19 - 08/27/19	DUT Type: Portable Tablet	Page 113 of 126	

11.3.1



Top Edge SPLSR Evaluation and Analysis

Table 11-12
Peak SAR Locations for Body Top Edge

Mode/Band	x (mm)	y (mm)
2.4 GHz WLAN Ant 1	-30.00	-74.00
2.4 GHz WLAN Ant 2	-34.00	73.40
LTE Band 13	-27.50	-24.00
LTE Band 7	-30.50	27.60

Table 11-13
Top Edge SAR to Peak Location Separation Ratio Calculations

Antenna Pair		Standalone SAR (W/kg)		Standalone SAR Sum (W/kg)	Peak SAR Separation Distance (mm)	SPLS Ratio	Plot Number
Ant "a"	Ant "b"	a	b	a+b	D _{a-b}	$(a+b)^{1.5}/D_{a-b}$	
2.4 GHz WLAN Ant 1	2.4 GHz WLAN Ant 2	0.125	0.386	0.511	147.45	0.00	49
2.4 GHz WLAN Ant 1	LTE Band 13	0.125	1.172	1.297	50.06	0.03	
2.4 GHz WLAN Ant 2	LTE Band 13	0.386	1.172	1.558	97.62	0.02	
2.4 GHz WLAN Ant 1	2.4 GHz WLAN Ant 2	0.125	0.386	0.511	147.45	0.00	50
2.4 GHz WLAN Ant 1	LTE Band 7	0.125	1.144	1.269	101.60	0.01	
2.4 GHz WLAN Ant 2	LTE Band 7	0.386	1.144	1.53	45.93	0.04	

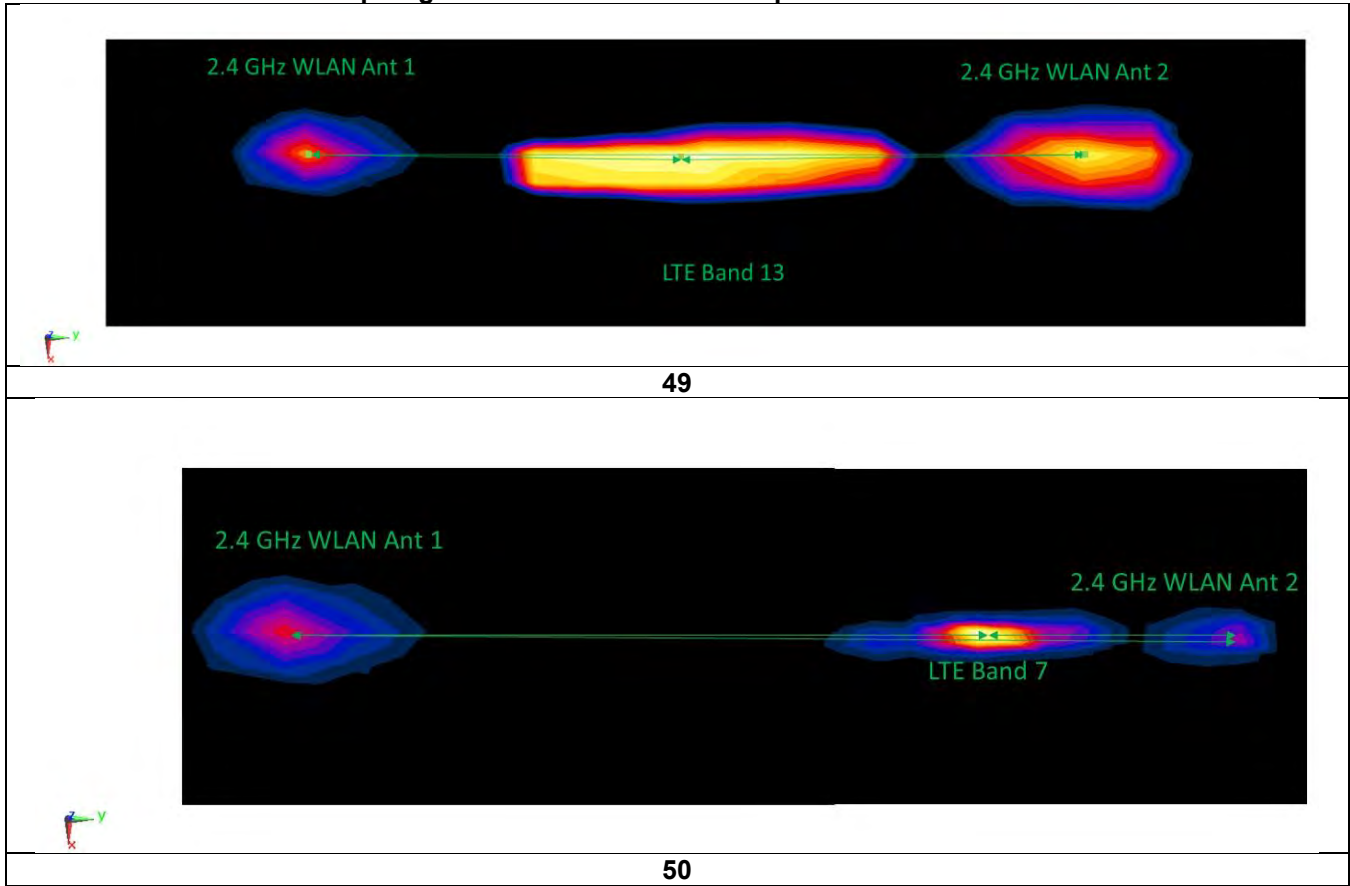

FCC ID: A3LSMT867U	 PCTEST ENGINEERING LABORATORY, INC.	SAR EVALUATION REPORT			Approved by: Quality Manager
Document S/N: 1M1907300131-01-R1.A3L	Test Dates: 08/05/19 - 08/27/19	DUT Type: Portable Tablet		Page 114 of 126	

**Table 11-14
Top Edge SAR to Peak Location Separation Ratio Plots**



11.4 Simultaneous Transmission Conclusion

The above numerical summed SAR results and SPLSR analysis are sufficient to determine that simultaneous transmission cases will not exceed the SAR limit and therefore no measured volumetric simultaneous SAR summation is required per FCC KDB Publication 447498 D01v06 and IEEE 1528- 2013 Section 6.3.4.1.

FCC ID: A3LSMT867U		SAR EVALUATION REPORT		Approved by: Quality Manager
Document S/N: 1M1907300131-01-R1.A3L	Test Dates: 08/05/19 - 08/27/19	DUT Type: Portable Tablet	Page 115 of 126	

12 SAR MEASUREMENT VARIABILITY

12.1 Measurement Variability

Per FCC KDB Publication 865664 D01v01r04, SAR measurement variability was assessed for each frequency band, which was determined by the SAR probe calibration point and tissue-equivalent medium used for the device measurements. When both head and body tissue-equivalent media were required for SAR measurements in a frequency band, the variability measurement procedures were applied to the tissue medium with the highest measured SAR, using the highest measured SAR configuration for that tissue-equivalent medium. These additional measurements were repeated after the completion of all measurements requiring the same head or body tissue-equivalent medium in a frequency band. The test device was returned to ambient conditions (normal room temperature) with the battery fully charged before it was re-mounted on the device holder for the repeated measurement(s) to minimize any unexpected variations in the repeated results.

SAR Measurement Variability was assessed using the following procedures for each frequency band:



- 1) When the original highest measured SAR is ≥ 0.80 W/kg, the measurement was repeated once.
- 2) A second repeated measurement was performed only if the ratio of largest to smallest SAR for the original and first repeated measurements was > 1.20 or when the original or repeated measurement was ≥ 1.45 W/kg (~ 10% from the 1g SAR limit).
- 3) A third repeated measurement was performed only if the original, first or second repeated measurement was ≥ 1.5 W/kg and the ratio of largest to smallest SAR for the original, first and second repeated measurements is > 1.20 .
- 4) Repeated measurements are not required when the original highest measured SAR is < 0.80 W/kg

**Table 12-1
Body SAR Measurement Variability Results**

BODY VARIABILITY RESULTS														
Band	FREQUENCY		Mode	Service	Data Rate (Mbps)	Side	Spacing	Measured SAR (1g)	1st Repeated SAR (1g)	Ratio	2nd Repeated SAR (1g)	Ratio	3rd Repeated SAR (1g)	Ratio
	MHz	Ch.						(W/kg)	(W/kg)		(W/kg)		(W/kg)	
835	826.40	4132	UMTS 850	RMC	N/A	back	0 mm	1.010	0.997	1.01	N/A	N/A	N/A	N/A
750	782.00	23230	LTE Band 13, 10 MHz Bandwidth	QPSK, 50 RB, 0 RB Offset	N/A	back	0 mm	1.070	1.020	1.05	N/A	N/A	N/A	N/A
1750	1720.00	132072	LTE Band 66 (AWS), 20 MHz Bandwidth	QPSK, 50 RB, 0 RB Offset	N/A	back	0 mm	1.000	0.997	1.00	N/A	N/A	N/A	N/A
1900	1905.00	26590	LTE Band 25 (PCS), 20 MHz Bandwidth	QPSK, 50 RB, 0 RB Offset	N/A	back	0 mm	0.994	0.975	1.02	N/A	N/A	N/A	N/A
2450	2510.00	20850	LTE Band 7, 20 MHz Bandwidth	QPSK, 50 RB, 0 RB Offset	N/A	top	0 mm	1.020	1.020	1.00	N/A	N/A	N/A	N/A
2600	2535.00	21100	LTE Band 7, 20 MHz Bandwidth	QPSK, 50 RB, 0 RB Offset	N/A	top	0 mm	0.969	0.966	1.00	N/A	N/A	N/A	N/A
5600	5500.00	100	802.11a, 20 MHz Bandwidth	OFDM, Antenna 2	6	right	8 mm	1.080	1.070	1.01	N/A	N/A	N/A	N/A
5750	5690.00	138	802.11ac, 80 MHz Bandwidth	OFDM, Antenna 2	29.3	right	0 mm	1.070	1.030	1.04	N/A	N/A	N/A	N/A
ANSI / IEEE C95.1 1992 - SAFETY LIMIT Spatial Peak Uncontrolled Exposure/General Population							Body 1.6 W/kg (mW/g) averaged over 1 gram							

12.2 Measurement Uncertainty

The measured SAR was < 1.5 W/kg for all frequency bands. Therefore, per KDB Publication 865664 D01v01r04, the extended measurement uncertainty analysis per IEEE 1528-2013 was not required.

FCC ID: A3LSMT867U		SAR EVALUATION REPORT		Approved by: Quality Manager
Document S/N: 1M1907300131-01-R1.A3L	Test Dates: 08/05/19 - 08/27/19	DUT Type: Portable Tablet	Page 116 of 126	



13 ADDITIONAL TESTING PER FCC GUIDANCE

13.1 Tuner Testing

The following test procedures were followed to demonstrate that the SAR results in Section 11 represented the appropriate SAR test conditions. For bands with dynamic tuning implemented, SAR was measured according to the required FCC SAR test procedures with the dynamic tuner active to allow the device to automatically tune to the antenna state for the respective RF exposure test configurations. Additional single point SAR time-sweep measurements were evaluated for other tuner states to determine that the other tuner configurations would result in equivalent or lower SAR values. The additional tuner hardware has no influence to the antenna characteristics, other than impedance matching.



Per April 2019 TCB Workshop notes, in order to evaluate all the tuner states, the 60 tuner states were divided among evenly among each supported band and exposure condition combination. Single point time-sweep measurements were performed at the peak SAR location determined by the zoom scan of the configuration with the highest reported SAR for each combination. The tuner state was able to be established remotely so that the device was not moved for the entire series of single point SAR for the tuner states in each combination. The SAR probe remained stationary at the same position throughout the entire series of single point measurements for each combination. When the single point SAR or 1g SAR was > 1.2 W/kg for a particular band/mode/exposure condition, point SAR measurements were made for all 60 states.

The operational description contains more information about the design and implementation of the dynamic antenna tuning.

FCC ID: A3LSMT867U	 PCTEST ENGINEERING LABORATORY, INC.	SAR EVALUATION REPORT		Approved by: Quality Manager
Document S/N: 1M1907300131-01-R1.A3L	Test Dates: 08/05/19 - 08/27/19	DUT Type: Portable Tablet		Page 117 of 126



**Table 13-1
Supplemental Body SAR Data**

UMTS B5		UMTS B4		UMTS B2		LTE B71		LTE B12	
RMC		RMC		RMC		QPSK 20 MHz Bandwidth, 50 RB, 0 RB Offset		QPSK 10 MHz Bandwidth, 50 RB, 0 RB Offset	
Test Position	Back	Test Position	Back	Test Position	Back	Test Position	Top	Test Position	Top
Spacing	0 mm	Spacing	0 mm	Spacing	0 mm	Spacing	0 mm	Spacing	0 mm
Frequency (MHz)	826.4	Frequency (MHz)	1752.6	Frequency (MHz)	1880	Frequency (MHz)	680.5	Frequency (MHz)	707.5
Channel	4132	Channel	1513	Channel	9400	Channel	133297	Channel	23095
Measured 1g SAR (W/kg)	1.010	Measured 1g SAR (W/kg)	0.986	Measured 1g SAR (W/kg)	0.813	Measured 1g SAR (W/kg)	0.591	Measured 1g SAR (W/kg)	0.754
Average Value of Time Sweep (W/kg)		Average Value of Time Sweep (W/kg)		Average Value of Time Sweep (W/kg)		Average Value of Time Sweep (W/kg)		Average Value of Time Sweep (W/kg)	
Auto-tune (State 54)	2.022	Auto-tune (State 26)	2.397	Auto-tune (State 2)	2.245	Auto-tune (State 51)	1.803	Auto-tune (State 50)	2.279
Default (State 48)	1.641	Default (State 36)	1.524	Default (State 24)	1.841	Default (State 0)	1.065	Default (State 0)	1.311
State 0	1.081	State 0	2.180	State 0	2.150	State 0	1.065	State 0	1.311
State 1	1.083	State 1	2.141	State 1	2.116	State 1	0.988	State 1	1.298
State 2	1.326	State 2	2.323	State 2	2.241	State 2	1.433	State 2	1.816
State 3	1.375	State 3	2.351	State 3	2.263	State 3	1.490	State 3	1.859
State 4	1.431	State 4	2.371	State 4	2.277	State 4	1.487	State 4	1.888
State 5	1.390	State 5	2.397	State 5	2.080	State 5	1.246	State 5	1.748
State 6	1.268	State 6	2.386	State 6	2.084	State 6	0.953	State 6	1.472
State 7	1.007	State 7	2.328	State 7	2.066	State 7	0.676	State 7	1.132
State 8	0.767	State 8	2.162	State 8	1.989	State 8	0.401	State 8	0.720
State 9	0.589	State 9	1.983	State 9	1.892	State 9	0.282	State 9	0.523
State 10	0.411	State 10	1.709	State 10	1.714	State 10	0.183	State 10	0.347
State 11	0.253	State 11	1.311	State 11	1.423	State 11	0.106	State 11	0.204
State 12	0.301	State 12	1.838	State 12	1.645	State 12	0.368	State 12	0.447
State 13	0.296	State 13	1.800	State 13	1.613	State 13	0.360	State 13	0.440
State 14	0.511	State 14	2.032	State 14	1.769	State 14	0.876	State 14	0.961
State 15	0.598	State 15	2.085	State 15	1.803	State 15	1.090	State 15	1.189
State 16	0.840	State 16	2.135	State 16	1.828	State 16	1.490	State 16	1.768
State 17	1.300	State 17	2.222	State 17	1.559	State 17	1.145	State 17	1.920
State 18	1.755	State 18	2.268	State 18	1.574	State 18	0.637	State 18	1.286
State 19	1.705	State 19	2.283	State 19	1.580	State 19	0.345	State 19	0.693
State 20	0.879	State 20	2.205	State 20	1.532	State 20	0.157	State 20	0.301
State 21	0.500	State 21	2.064	State 21	1.452	State 21	0.098	State 21	0.184
State 22	0.257	State 22	1.807	State 22	1.303	State 22	0.058	State 22	0.107
State 23	0.120	State 23	1.389	State 23	1.047	State 23	0.030	State 23	0.056
State 24	0.437	State 24	1.774	State 24	1.841	State 24	0.493	State 24	0.591
State 25	0.432	State 25	2.180	State 25	2.150	State 25	0.485	State 25	1.311
State 26	0.481	State 26	2.433	State 26	1.475	State 26	0.675	State 26	0.780
State 27	0.471	State 27	2.011	State 27	1.497	State 27	0.640	State 27	0.783
State 28	0.436	State 28	2.057	State 28	1.520	State 28	0.549	State 28	0.714
State 29	0.367	State 29	2.125	State 29	1.566	State 29	0.390	State 29	0.558
State 30	0.300	State 30	2.144	State 30	1.586	State 30	0.269	State 30	0.412
State 31	0.234	State 31	2.114	State 31	1.594	State 31	0.182	State 31	0.290
State 32	0.159	State 32	1.962	State 32	1.552	State 32	0.106	State 32	0.174
State 33	0.121	State 33	1.772	State 33	1.475	State 33	0.075	State 33	0.124
State 34	0.086	State 34	1.480	State 34	1.326	State 34	0.049	State 34	0.083
State 35	0.054	State 35	1.076	State 35	1.063	State 35	0.029	State 35	0.051
State 36	0.158	State 36	1.524	State 36	1.122	State 36	0.211	State 36	0.243
State 37	0.155	State 37	1.386	State 37	1.091	State 37	0.206	State 37	0.238
State 38	0.343	State 38	1.644	State 38	1.250	State 38	0.774	State 38	0.790
State 39	0.433	State 39	1.716	State 39	1.295	State 39	0.995	State 39	1.066
State 40	0.689	State 40	1.787	State 40	1.328	State 40	0.812	State 40	1.279
State 41	0.881	State 41	1.934	State 41	1.419	State 41	0.317	State 41	0.601
State 42	0.611	State 42	2.021	State 42	1.471	State 42	0.146	State 42	0.271
State 43	0.313	State 43	2.193	State 43	1.533	State 43	0.076	State 43	0.136
State 44	0.127	State 44	2.077	State 44	1.558	State 44	0.035	State 44	0.062
State 45	0.075	State 45	1.880	State 45	1.516	State 45	0.022	State 45	0.039
State 46	0.042	State 46	1.557	State 46	1.387	State 46	0.013	State 46	0.024
State 47	0.021	State 47	1.101	State 47	1.112	State 47	0.007	State 47	0.013
State 48	1.641	State 48	1.323	State 48	0.563	State 48	1.285	State 48	1.798
State 49	1.632	State 49	1.278	State 49	0.518	State 49	1.274	State 49	1.785
State 50	1.806	State 50	1.160	State 50	0.552	State 50	1.678	State 50	2.280
State 51	1.849	State 51	1.143	State 51	0.524	State 51	1.813	State 51	2.290
State 52	1.912	State 52	1.051	State 52	0.534	State 52	1.805	State 52	2.385
State 53	1.976	State 53	0.901	State 53	0.473	State 53	1.705	State 53	2.389
State 54	2.020	State 54	0.813	State 54	0.443	State 54	1.484	State 54	2.255
State 55	2.010	State 55	0.682	State 55	0.378	State 55	1.189	State 55	1.995
State 56	1.923	State 56	0.530	State 56	0.298	State 56	0.796	State 56	1.524
State 57	1.802	State 57	0.432	State 57	0.242	State 57	0.590	State 57	1.204
State 58	1.577	State 58	0.330	State 58	0.183	State 58	0.399	State 58	0.863
State 59	1.225	State 59	0.225	State 59	0.121	State 59	0.239	State 59	0.539

FCC ID: A3LSMT867U	 PCTEST <small>ENGINEERING LABORATORY, INC.</small>	SAR EVALUATION REPORT		Approved by: Quality Manager
Document S/N: 1M1907300131-01-R1.A3L	Test Dates: 08/05/19 - 08/27/19	DUT Type: Portable Tablet		Page 118 of 126

**Table 13-2
Supplemental Body SAR Data Continued**

LTE B13		LTE B26 (+5)		LTE B66 (+4)		LTE B2		LTE B25	
QPSK 10 MHz Bandwidth, 50 RB, 0 RB Offset		QPSK 15 MHz Bandwidth, 1 RB, 0 RB Offset		QPSK 20 MHz Bandwidth, 50 RB, 0 RB Offset		QPSK 20 MHz Bandwidth, 50 RB, 0 RB Offset		QPSK 20 MHz Bandwidth, 50 RB, 0 RB Offset	
Test Position	Back	Test Position	Top	Test Position	Back	Test Position	Back	Test Position	Back
Spacing	0 mm	Spacing	0 mm	Spacing	0 mm	Spacing	0 mm	Spacing	0 mm
Frequency (MHz)	782.0	Frequency (MHz)	831.5	Frequency (MHz)	1720.0	Frequency (MHz)	1880.0	Frequency (MHz)	1905.0
Channel	23230	Channel	26865	Channel	132072	Channel	18900	Channel	26590
Measured 1g SAR (W/kg)	1.070	Measured 1g SAR (W/kg)	0.910	Measured 1g SAR (W/kg)	1.000	Measured 1g SAR (W/kg)	0.877	Measured 1g SAR (W/kg)	0.994
Average Value of Time Sweep (W/kg)		Average Value of Time Sweep (W/kg)		Average Value of Time Sweep (W/kg)		Average Value of Time Sweep (W/kg)		Average Value of Time Sweep (W/kg)	
Auto-tune (State 52)	2.586	Auto-tune (State 52)	1.834	Auto-tune (State 26)	2.485	Auto-tune (State 24)	2.516	Auto-tune (State 3)	2.250
Default (State 48)	2.243	Default (State 48)	1.694	Default (State 36)	2.020	Default (State 24)	2.518	Default (State 24)	2.334
State 0	1.531	State 0	1.235	State 0	2.522	State 0	2.474	State 0	1.966
State 1	1.517	State 1	1.222	State 1	2.486	State 1	2.447	State 1	2.244
State 2	1.990	State 2	1.553	State 2	2.574	State 2	2.565	State 2	2.200
State 3	2.089	State 3	1.613	State 3	2.541	State 3	2.585	State 3	2.326
State 4	2.242	State 4	1.718	State 4	2.500	State 4	2.589	State 4	2.334
State 5	2.269	State 5	1.733	State 5	2.384	State 5	2.617	State 5	2.354
State 6	2.128	State 6	1.651	State 6	2.287	State 6	2.601	State 6	2.350
State 7	1.824	State 7	1.452	State 7	2.097	State 7	2.556	State 7	2.326
State 8	1.315	State 8	1.089	State 8	1.785	State 8	2.453	State 8	2.266
State 9	0.999	State 9	0.849	State 9	1.558	State 9	2.342	State 9	2.127
State 10	0.684	State 10	0.598	State 10	1.272	State 10	2.132	State 10	1.971
State 11	0.409	State 11	0.369	State 11	0.931	State 11	1.775	State 11	1.746
State 12	0.453	State 12	0.336	State 12	2.248	State 12	2.109	State 12	1.401
State 13	0.448	State 13	0.332	State 13	2.199	State 13	2.072	State 13	1.927
State 14	0.793	State 14	0.540	State 14	2.414	State 14	2.246	State 14	1.888
State 15	0.938	State 15	0.619	State 15	2.448	State 15	2.283	State 15	2.078
State 16	1.333	State 16	0.836	State 16	2.461	State 16	2.308	State 16	2.117
State 17	2.031	State 17	1.237	State 17	2.446	State 17	2.371	State 17	2.143
State 18	2.538	State 18	1.718	State 18	2.398	State 18	2.391	State 18	2.185
State 19	2.150	State 19	1.963	State 19	2.266	State 19	2.391	State 19	2.199
State 20	1.043	State 20	1.280	State 20	1.999	State 20	2.338	State 20	2.198
State 21	0.601	State 21	0.760	State 21	1.756	State 21	2.247	State 21	2.114
State 22	0.316	State 22	0.390	State 22	1.435	State 22	2.073	State 22	1.988
State 23	0.150	State 23	0.177	State 23	1.033	State 23	1.735	State 23	1.769
State 24	0.643	State 24	0.490	State 24	2.020	State 24	2.138	State 24	1.410
State 25	1.531	State 25	0.483	State 25	2.313	State 25	2.474	State 25	1.966
State 26	0.761	State 26	0.547	State 26	2.481	State 26	2.322	State 26	1.929
State 27	0.760	State 27	0.541	State 27	2.481	State 27	2.383	State 27	2.133
State 28	0.721	State 28	0.506	State 28	2.471	State 28	2.418	State 28	2.169
State 29	0.614	State 29	0.431	State 29	2.420	State 29	2.510	State 29	2.209
State 30	0.501	State 30	0.357	State 30	2.344	State 30	2.579	State 30	2.272
State 31	0.383	State 31	0.280	State 31	2.181	State 31	2.610	State 31	2.303
State 32	0.253	State 32	0.191	State 32	1.881	State 32	2.601	State 32	2.301
State 33	0.188	State 33	0.146	State 33	1.640	State 33	2.523	State 33	2.217
State 34	0.130	State 34	0.102	State 34	1.332	State 34	2.316	State 34	2.093
State 35	0.080	State 35	0.064	State 35	0.960	State 35	1.922	State 35	1.870
State 36	0.243	State 36	0.171	State 36	2.020	State 36	1.736	State 36	1.481
State 37	0.238	State 37	0.167	State 37	1.962	State 37	1.696	State 37	1.622
State 38	0.583	State 38	0.364	State 38	2.241	State 38	1.931	State 38	1.584
State 39	0.756	State 39	0.455	State 39	2.298	State 39	2.001	State 39	1.801
State 40	1.240	State 40	0.723	State 40	2.344	State 40	2.050	State 40	1.862
State 41	1.274	State 41	0.982	State 41	2.403	State 41	2.207	State 41	1.907
State 42	0.707	State 42	0.728	State 42	2.412	State 42	2.291	State 42	2.034
State 43	0.340	State 43	0.380	State 43	2.329	State 43	2.409	State 43	2.100
State 44	0.139	State 44	0.152	State 44	2.112	State 44	2.495	State 44	2.177
State 45	0.083	State 45	0.089	State 45	1.867	State 45	2.487	State 45	2.192
State 46	0.046	State 46	0.048	State 46	1.519	State 46	2.352	State 46	2.114
State 47	0.024	State 47	0.023	State 47	1.078	State 47	1.963	State 47	1.921
State 48	2.243	State 48	1.694	State 48	1.477	State 48	0.854	State 48	1.529
State 49	2.299	State 49	1.688	State 49	1.431	State 49	0.789	State 49	0.843
State 50	2.530	State 50	1.757	State 50	1.342	State 50	0.820	State 50	0.787
State 51	2.584	State 51	1.767	State 51	1.258	State 51	0.774	State 51	0.818
State 52	2.565	State 52	1.786	State 52	1.205	State 52	0.770	State 52	0.775
State 53	2.714	State 53	1.790	State 53	1.031	State 53	0.670	State 53	0.780
State 54	2.719	State 54	1.776	State 54	0.925	State 54	0.618	State 54	0.684
State 55	2.673	State 55	1.752	State 55	0.773	State 55	0.519	State 55	0.635
State 56	2.485	State 56	1.665	State 56	0.599	State 56	0.404	State 56	0.535
State 57	2.211	State 57	1.591	State 57	0.485	State 57	0.352	State 57	0.417
State 58	1.995	State 58	1.443	State 58	0.370	State 58	0.244	State 58	0.337
State 59	1.512	State 59	1.215	State 59	0.252	State 59	0.162	State 59	0.255

FCC ID: A3LSMT867U		SAR EVALUATION REPORT		Approved by: Quality Manager
Document S/N: 1M1907300131-01-R1.A3L	Test Dates: 08/05/19 - 08/27/19	DUT Type: Portable Tablet		Page 119 of 126

13.2 LTE Band 41 Power Class 2 and Power Class 3 Linearity

This device supports Power Class 2 and Power Class 3 operations for LTE Band 41. The highest available duty cycle for Power Class 2 operations is 43.3 % using UL-DL configuration 1. Per May 2017 TCB Workshop Notes based on the device behavior, all SAR tests were performed using Power Class 3. SAR with Power Class 2 at the highest power and available duty factor was additionally performed for the Power Class 3 configuration with the highest SAR for each exposure condition. The linearity between the Power Class 2 and Power Class 3 SAR results and the respective frame averaged powers was calculated to determine that the results were linear. When ULCA is active, the linearity between the Power Class 2 with ULCA active and Power Class 3 with ULCA active SAR results and the respective frame averaged powers was calculated to determine that the results were linear. Per May 2017 TCB Workshop, no additional SAR measurements were required since the linearity between power classes was < 10% and all reported SAR values were < 1.4 W/kg for 1g and < 3.5 W/kg for 10g.

Table 13-3
LTE Band 41 Body Linearity Data

	LTE Band 41 PC3	LTE Band 41 PC2
Maximum Allowed Output Power (dBm)	14	14
Measured Output Power (dBm)	13.72	13.95
Measured SAR (W/kg)	0.653	0.438
Measured Power (mW)	23.55	24.83
Duty Cycle	63.3%	43.3%
Frame Averaged Output Power (mW)	14.91	10.75
% deviation from expected linearity		-7.00%

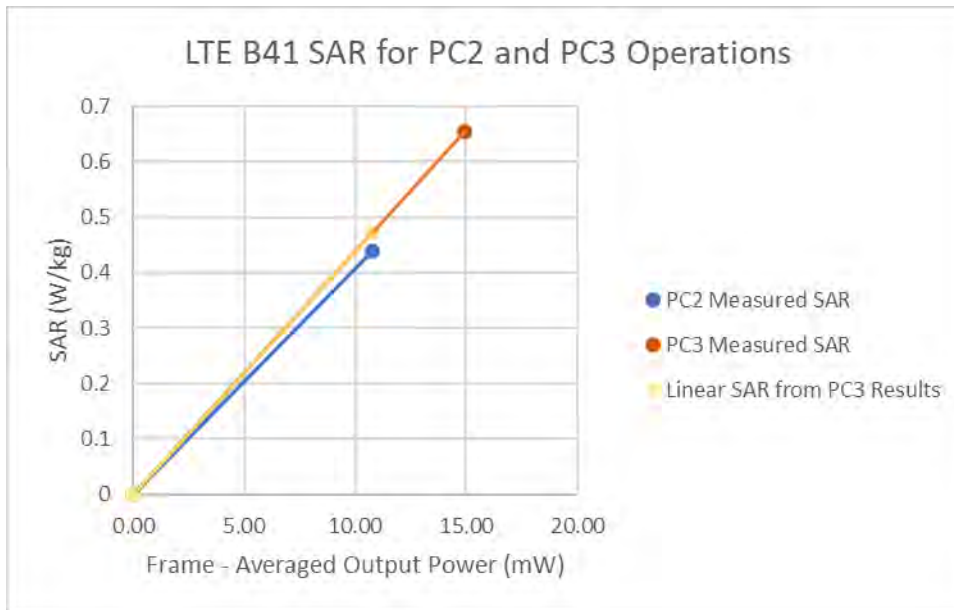

Figure 13-1
LTE Band 41 Body Linearity



FCC ID: A3LSMT867U	 PCTEST ENGINEERING LABORATORY, INC.	SAR EVALUATION REPORT		Approved by: Quality Manager
Document S/N: 1M1907300131-01-R1.A3L	Test Dates: 08/05/19 - 08/27/19	DUT Type: Portable Tablet		Page 120 of 126

Table 13-4
LTE Band 41 ULCA Body Linearity Data

	LTE Band 41 PC3	LTE Band 41 PC2
Maximum Allowed Output Power (dBm)	14	14
Measured Output Power (dBm)	14	14
Measured SAR (W/kg)	0.685	0.465
Measured Power (mW)	25.12	25.12
Duty Cycle	63.3%	43.3%
Frame Averaged Output Power (mW)	15.90	10.88
% deviation from expected linearity		-0.76%

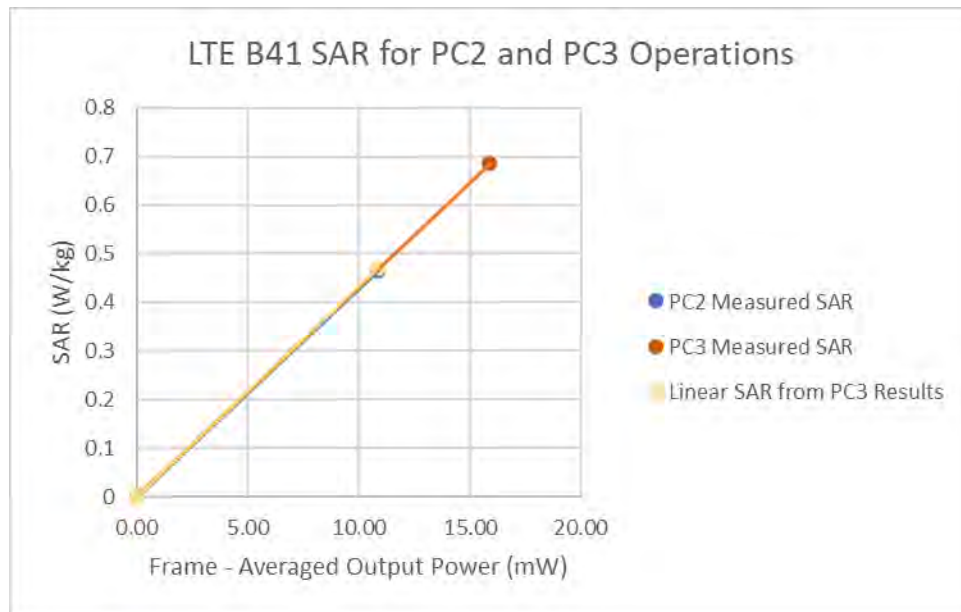





Figure 13-2
LTE Band 41 ULCA Body Linearity

FCC ID: A3LSMT867U		SAR EVALUATION REPORT		Approved by: Quality Manager
Document S/N: 1M1907300131-01-R1.A3L	Test Dates: 08/05/19 - 08/27/19	DUT Type: Portable Tablet	Page 121 of 126	

Manufacturer	Model	Description	Cal Date	Cal Interval	Cal Due	Serial Number
Agilent	8594A	(9kHz-2.9GHz) Spectrum Analyzer	N/A	N/A	N/A	3051A00187
Agilent	E5515C	8960 Series 10 Wireless Communications Test Set	12/18/2018	Annual	12/18/2019	GB42230325
Agilent	E4438C	ESG Vector Signal Generator	3/8/2019	Biennial	3/8/2021	MY42082385
Agilent	N9020A	MXA Signal Analyzer	4/20/2019	Annual	4/20/2020	US46470561
Agilent	N5182A	MXG Vector Signal Generator	11/28/2018	Annual	11/28/2019	MY47420603
Agilent	8753ES	S-Parameter Network Analyzer	3/11/2019	Annual	3/11/2020	US39170122
Agilent	N4010A	Wireless Connectivity Test Set	CBT	N/A	CBT	GB44450273
Amplifier Research	1551G6	Amplifier	CBT	N/A	CBT	433976
Amplifier Research	1551G6	Amplifier	CBT	N/A	CBT	433978
Anritsu	MA2411B	Pulse Power Sensor	11/20/2018	Annual	11/20/2019	1339008
Anritsu	MA2411B	Pulse Power Sensor	3/6/2019	Annual	3/6/2020	1339018
Anritsu	ML2495A	Power Meter	10/5/2018	Annual	10/5/2019	1328004
Anritsu	ML2496A	Power Meter	10/21/2018	Annual	10/21/2019	1138001
Anritsu	MT8820C	Radio Communication Analyzer	7/25/2019	Annual	7/25/2020	6201240328
Anritsu	MT8821C	Radio Communication Analyzer	1/25/2019	Annual	1/25/2020	6261895213
Anritsu	MT8821C	Radio Communication Analyzer	3/18/2019	Annual	3/18/2020	6201144419
Anritsu	MA24106A	USB Power Sensor	4/17/2019	Annual	4/17/2020	1344556
Anritsu	MA24106A	USB Power Sensor	9/20/2018	Annual	9/20/2019	1344559
COMTECH	AR85729-5	Solid State Amplifier	CBT	N/A	CBT	M155A00-009
COMTECH	AR85729-5/5759B	Solid State Amplifier	CBT	N/A	CBT	M3W1A00-1002
Control Company	4352	Long Stem Thermometer	6/26/2019	Biennial	6/26/2021	192282739
Control Company	4352	Long Stem Thermometer	6/26/2019	Biennial	6/26/2021	192282744
Control Company	4040	Therm./Clock/Humidity Monitor	6/29/2019	Biennial	6/29/2021	192291463
Control Company	4040	Therm./Clock/Humidity Monitor	6/29/2019	Biennial	6/29/2021	192291470
Control Company	4352	Ultra Long Stem Thermometer	11/29/2018	Biennial	11/29/2020	181766777
Control Company	4352	Ultra Long Stem Thermometer	11/29/2018	Biennial	11/29/2020	181766801
Keysight	772D	Dual Directional Coupler	CBT	N/A	CBT	MY52180215
Keysight Technologies	N6705B	DC Power Analyzer	4/27/2019	Biennial	4/27/2021	MY53004059
Keysight Technologies	85033E	Standard Mechanical Calibration Kit (DC to 9GHz, 3.5mm)	7/2/2019	Annual	7/2/2020	MY53401181
MCL	BW-N6W5+	6dB Attenuator	CBT	N/A	CBT	1139
MiniCircuits	SLP-2400+	Low Pass Filter	CBT	N/A	CBT	R8979500903
MiniCircuits	VLF-6000+	Low Pass Filter	CBT	N/A	CBT	N/A
Mini-Circuits	BW-N20W5+	DC to 18 GHz Precision Fixed 20 dB Attenuator	CBT	N/A	CBT	N/A
Mini-Circuits	NLP-1200+	Low Pass Filter DC to 1000 MHz	CBT	N/A	CBT	N/A
Mini-Circuits	NLP-2950+	Low Pass Filter DC to 2700 MHz	CBT	N/A	CBT	N/A
Mini-Circuits	BW-N20W5	Power Attenuator	CBT	N/A	CBT	1226
Mitutoyo	CD-6°CSX	Digital Caliper	4/18/2018	Biennial	4/18/2020	13264165
Narda	4014C-6	4 - 8 GHz SMA 6 dB Directional Coupler	CBT	N/A	CBT	N/A
Narda	4772-3	Attenuator (3dB)	CBT	N/A	CBT	9406
Narda	BW-53W2	Attenuator (3dB)	CBT	N/A	CBT	120
Pasternack	PE2208-6	Bidirectional Coupler	CBT	N/A	CBT	N/A
Pasternack	PE2209-10	Bidirectional Coupler	CBT	N/A	CBT	N/A
Pasternack	NC-100	Torque Wrench	11/1/2017	Biennial	11/1/2019	N/A
Pasternack	NC-100	Torque Wrench	11/7/2017	Biennial	11/7/2019	N/A
Rohde & Schwarz	CMW500	Radio Communication Tester	10/12/2018	Annual	10/12/2019	166462
Rohde & Schwarz	CMW500	Radio Communication Tester	4/15/2019	Annual	4/15/2020	167283
Rohde & Schwarz	CMW500	Radio Communication Tester	4/16/2019	Annual	4/16/2020	167286
SPEAG	DAK-3.5	Dielectric Assessment Kit	9/11/2018	Annual	9/11/2019	1091
SPEAG	D750V3	750 MHz SAR Dipole	1/15/2018	Biennial	1/15/2020	1003
SPEAG	D835V2	835 MHz SAR Dipole	3/13/2019	Annual	3/13/2020	4d047
SPEAG	D1765V2	1765 MHz SAR Dipole	5/23/2018	Biennial	5/23/2020	1008
SPEAG	D1750V2	1750 MHz SAR Dipole	5/15/2019	Annual	5/15/2020	1148
SPEAG	D1900V2	1900 MHz SAR Dipole	10/23/2018	Annual	10/23/2019	5d080
SPEAG	D1900V2	1900 MHz SAR Dipole	2/21/2019	Annual	2/21/2020	5d148
SPEAG	D2450V2	2450 MHz SAR Dipole	8/17/2017	Biennial	8/17/2019	719
SPEAG	D2450V2	2450 MHz SAR Dipole	9/11/2017	Biennial	9/11/2019	797
SPEAG	D2600V2	2600 MHz SAR Dipole	4/11/2018	Biennial	4/11/2020	1004
SPEAG	D5GHzV2	5 GHz SAR Dipole	1/16/2018	Biennial	1/16/2020	1057
SPEAG	DAE4	Dasy Data Acquisition Electronics	2/13/2019	Annual	2/13/2020	665
SPEAG	DAE4	Dasy Data Acquisition Electronics	5/8/2019	Annual	5/8/2020	728
SPEAG	DAE4	Dasy Data Acquisition Electronics	5/8/2019	Annual	5/8/2020	859
SPEAG	DAE4	Dasy Data Acquisition Electronics	7/11/2019	Annual	7/11/2020	1322
SPEAG	DAE4	Dasy Data Acquisition Electronics	6/20/2019	Annual	6/20/2020	1334
SPEAG	DAE4	Dasy Data Acquisition Electronics	4/18/2019	Annual	4/18/2020	1407
SPEAG	DAE4	Dasy Data Acquisition Electronics	1/15/2019	Annual	1/15/2020	1530
SPEAG	EX3DV4	SAR Probe	4/24/2019	Annual	4/24/2020	7357
SPEAG	EX3DV4	SAR Probe	5/16/2019	Annual	5/16/2020	7406
SPEAG	EX3DV4	SAR Probe	6/19/2019	Annual	6/19/2020	7409
SPEAG	EX3DV4	SAR Probe	7/16/2019	Annual	7/16/2020	7410
SPEAG	EX3DV4	SAR Probe	2/19/2019	Annual	2/19/2020	7417
SPEAG	EX3DV4	SAR Probe	1/24/2019	Annual	1/24/2020	7488
SPEAG	EX3DV4	SAR Probe	5/16/2019	Annual	5/16/2020	7538



Each piece of equipment was used solely within its calibration period.

Note: CBT (Calibrated Before Testing). Prior to testing, the measurement paths containing a cable, amplifier, attenuator, coupler or filter were connected to a calibrated source (i.e. a signal generator) to determine the losses of the measurement path. The power meter offset was then adjusted to compensate for the measurement system losses. This level offset is stored within the power meter before measurements are made. This calibration verification procedure applies to the system verification and output power measurements. The calibrated reading is then taken directly from the power meter after compensation of the losses for all final power measurements.

FCC ID: A3LSMT867U		SAR EVALUATION REPORT		Approved by: Quality Manager
Document S/N: 1M1907300131-01-R1.A3L	Test Dates: 08/05/19 - 08/27/19	DUT Type: Portable Tablet		Page 122 of 126

15 MEASUREMENT UNCERTAINTIES

a	c	d	e= f(d,k)	f	g	h = c x f/e	i = c x g/e	k
Uncertainty Component	Tol. (± %)	Prob. Dist.	Div.	c ₁ 1gm	c ₁ 10 gms	1gm u ₁ (± %)	10gms u ₁ (± %)	v ₁
Measurement System								
Probe Calibration	6.55	N	1	1.0	1.0	6.6	6.6	∞
Axial Isotropy	0.25	N	1	0.7	0.7	0.2	0.2	∞
Hemishperical Isotropy	1.3	N	1	0.7	0.7	0.9	0.9	∞
Boundary Effect	2.0	R	1.73	1.0	1.0	1.2	1.2	∞
Linearity	0.3	N	1	1.0	1.0	0.3	0.3	∞
System Detection Limits	0.25	R	1.73	1.0	1.0	0.1	0.1	∞
Readout Electronics	0.3	N	1	1.0	1.0	0.3	0.3	∞
Response Time	0.8	R	1.73	1.0	1.0	0.5	0.5	∞
Integration Time	2.6	R	1.73	1.0	1.0	1.5	1.5	∞
RF Ambient Conditions - Noise	3.0	R	1.73	1.0	1.0	1.7	1.7	∞
RF Ambient Conditions - Reflections	3.0	R	1.73	1.0	1.0	1.7	1.7	∞
Probe Positioner Mechanical Tolerance	0.4	R	1.73	1.0	1.0	0.2	0.2	∞
Probe Positioning w/ respect to Phantom	6.7	R	1.73	1.0	1.0	3.9	3.9	∞
Extrapolation, Interpolation & Integration algorithms for Max. SAR Evaluation	4.0	R	1.73	1.0	1.0	2.3	2.3	∞
Test Sample Related								
Test Sample Positioning	2.7	N	1	1.0	1.0	2.7	2.7	35
Device Holder Uncertainty	1.67	N	1	1.0	1.0	1.7	1.7	5
Output Power Variation - SAR drift measurement	5.0	R	1.73	1.0	1.0	2.9	2.9	∞
SAR Scaling	0.0	R	1.73	1.0	1.0	0.0	0.0	∞
Phantom & Tissue Parameters								
Phantom Uncertainty (Shape & Thickness tolerances)	7.6	R	1.73	1.0	1.0	4.4	4.4	∞
Liquid Conductivity - measurement uncertainty	4.2	N	1	0.78	0.71	3.3	3.0	10
Liquid Permittivity - measurement uncertainty	4.1	N	1	0.23	0.26	1.0	1.1	10
Liquid Conductivity - Temperature Uncertainty	3.4	R	1.73	0.78	0.71	1.5	1.4	∞
Liquid Permittivity - Temperature Uncertainty	0.6	R	1.73	0.23	0.26	0.1	0.1	∞
Liquid Conductivity - deviation from target values	5.0	R	1.73	0.64	0.43	1.8	1.2	∞
Liquid Permittivity - deviation from target values	5.0	R	1.73	0.60	0.49	1.7	1.4	∞
Combined Standard Uncertainty (k=1)	RSS					11.5	11.3	60
Expanded Uncertainty (95% CONFIDENCE LEVEL)	k=2					23.0	22.6	



FCC ID: A3LSMT867U	 PCTEST ENGINEERING LABORATORY, INC.	SAR EVALUATION REPORT		Approved by: Quality Manager
Document S/N: 1M1907300131-01-R1.A3L	Test Dates: 08/05/19 - 08/27/19	DUT Type: Portable Tablet	Page 123 of 126	

16 CONCLUSION

16.1 Measurement Conclusion



The SAR evaluation indicates that the EUT complies with the RF radiation exposure limits of the FCC and Innovation, Science, and Economic Development Canada, with respect to all parameters subject to this test. These measurements were taken to simulate the RF effects of RF exposure under worst-case conditions. Precise laboratory measures were taken to assure repeatability of the tests. The results and statements relate only to the item(s) tested.

Please note that the absorption and distribution of electromagnetic energy in the body are very complex phenomena that depend on the mass, shape, and size of the body, the orientation of the body with respect to the field vectors, and the electrical properties of both the body and the environment. Other variables that may play a substantial role in possible biological effects are those that characterize the environment (e.g. ambient temperature, air velocity, relative humidity, and body insulation) and those that characterize the individual (e.g. age, gender, activity level, debilitation, or disease). Because various factors may interact with one another to vary the specific biological outcome of an exposure to electromagnetic fields, any protection guide should consider maximal amplification of biological effects as a result of field-body interactions, environmental conditions, and physiological variables. [3]



FCC ID: A3LSMT867U		SAR EVALUATION REPORT		Approved by: Quality Manager
Document S/N: 1M1907300131-01-R1.A3L	Test Dates: 08/05/19 - 08/27/19	DUT Type: Portable Tablet		Page 124 of 126

17 REFERENCES

- [1] Federal Communications Commission, ET Docket 93-62, Guidelines for Evaluating the Environmental Effects of Radiofrequency Radiation, Aug. 1996.
- [2] ANSI/IEEE C95.1-2005, American National Standard safety levels with respect to human exposure to radio frequency electromagnetic fields, 3kHz to 300GHz, New York: IEEE, 2006.
- [3] ANSI/IEEE C95.1-1992, American National Standard safety levels with respect to human exposure to radio frequency electromagnetic fields, 3kHz to 300GHz, New York: IEEE, Sept. 1992.
- [4] ANSI/IEEE C95.3-2002, IEEE Recommended Practice for the Measurement of Potentially Hazardous Electromagnetic Fields - RF and Microwave, New York: IEEE, December 2002.
- [5] IEEE Standards Coordinating Committee 39 –Standards Coordinating Committee 34 – IEEE Std. 1528-2013, IEEE Recommended Practice for Determining the Peak Spatial-Average Specific Absorption Rate (SAR) in the Human Head from Wireless Communications Devices: Measurement Techniques.
- [6] NCRP, National Council on Radiation Protection and Measurements, Biological Effects and Exposure Criteria for RadioFrequency Electromagnetic Fields, NCRP Report No. 86, 1986. Reprinted Feb. 1995.
- [7] T. Schmid, O. Egger, N. Kuster, Automated E-field scanning system for dosimetric assessments, IEEE Transaction on Microwave Theory and Techniques, vol. 44, Jan. 1996, pp. 105-113.
- [8] K. Pokovic, T. Schmid, N. Kuster, Robust setup for precise calibration of E-field probes in tissue simulating liquids at mobile communications frequencies, ICECOM97, Oct. 1997, pp. 1 -124.
- [9] K. Pokovic, T. Schmid, and N. Kuster, E-field Probe with improved isotropy in brain simulating liquids, Proceedings of the ELMAR, Zadar, Croatia, June 23-25, 1996, pp. 172-175.
- [10] Schmid & Partner Engineering AG, Application Note: Data Storage and Evaluation, June 1998, p2.
- [11] V. Hombach, K. Meier, M. Burkhardt, E. Kuhn, N. Kuster, The Dependence of EM Energy Absorption upon Human Modeling at 900 MHz, IEEE Transaction on Microwave Theory and Techniques, vol. 44 no. 10, Oct. 1996, pp. 1865-1873.
- [12] N. Kuster and Q. Balzano, Energy absorption mechanism by biological bodies in the near field of dipole antennas above 300MHz, IEEE Transaction on Vehicular Technology, vol. 41, no. 1, Feb. 1992, pp. 17-23.
- [13] G. Hartsgrove, A. Kraszewski, A. Surowiec, Simulated Biological Materials for Electromagnetic Radiation Absorption Studies, University of Ottawa, Bioelectromagnetics, Canada: 1987, pp. 29-36.
- [14] Q. Balzano, O. Garay, T. Manning Jr., Electromagnetic Energy Exposure of Simulated Users of Portable Cellular Telephones, IEEE Transactions on Vehicular Technology, vol. 44, no.3, Aug. 1995.
- [15] W. Gander, Computermathematik, Birkhaeuser, Basel, 1992.
- [16] W.H. Press, S.A. Teukolsky, W.T. Vetterling, and B.P. Flannery, Numerical Recipes in C, The Art of Scientific Computing, Second edition, Cambridge University Press, 1992.
- [17] N. Kuster, R. Kastle, T. Schmid, Dosimetric evaluation of mobile communications equipment with known precision, IEEE Transaction on Communications, vol. E80-B, no. 5, May 1997, pp. 645-652.

FCC ID: A3LSMT867U	 PCTEST ENGINEERING LABORATORY, INC.	SAR EVALUATION REPORT		Approved by: Quality Manager
Document S/N: 1M1907300131-01-R1.A3L	Test Dates: 08/05/19 - 08/27/19	DUT Type: Portable Tablet	Page 125 of 126	

- [18] CENELEC CLC/SC111B, European Prestandard (prENV 50166-2), Human Exposure to Electromagnetic Fields High-frequency: 10kHz-300GHz, Jan. 1995.
- [19] Prof. Dr. Niels Kuster, ETH, Eidgenössische Technische Hochschule Zürich, Dosimetric Evaluation of the Cellular Phone.
- [20] IEC 62209-1, Measurement procedure for the assessment of specific absorption rate of human exposure to radio frequency fields from hand-held and body-mounted wireless communication devices - Part 1: Devices used next to the ear (Frequency range of 300 MHz to 6 GHz), July 2016.
- [21] Innovation, Science, Economic Development Canada RSS-102 Radio Frequency Exposure Compliance of Radiocommunication Apparatus (All Frequency Bands) Issue 5, March 2015.
- [22] Health Canada Safety Code 6 Limits of Human Exposure to Radio Frequency Electromagnetic Fields in the Frequency Range from 3 kHz – 300 GHz, 2015
- [23] FCC SAR Test Procedures for 2G-3G Devices, Mobile Hotspot and UMPC Devices KDB Publications 941225, D01-D07
- [24] SAR Measurement Guidance for IEEE 802.11 Transmitters, KDB Publication 248227 D01
- [25] FCC SAR Considerations for Handsets with Multiple Transmitters and Antennas, KDB Publications 648474 D03-D04
- [26] FCC SAR Evaluation Considerations for Laptop, Notebook, Netbook and Tablet Computers, FCC KDB Publication 616217 D04
- [27] FCC SAR Measurement and Reporting Requirements for 100MHz – 6 GHz, KDB Publications 865664 D01-D02
- [28] FCC General RF Exposure Guidance and SAR Procedures for Dongles, KDB Publication 447498, D01-D02
- [29] Anexo à Resolução No. 533, de 10 de Setembro de 2009.
- [30] IEC 62209-2, Human exposure to radio frequency fields from hand-held and body-mounted wireless communication devices - Human models, instrumentation, and procedures - Part 2: Procedure to determine the specific absorption rate (SAR) for wireless communication devices used in close proximity to the human body (frequency range of 30 MHz to 6 GHz), Mar. 2010.

FCC ID: A3LSMT867U		SAR EVALUATION REPORT		Approved by: Quality Manager
Document S/N: 1M1907300131-01-R1.A3L	Test Dates: 08/05/19 - 08/27/19	DUT Type: Portable Tablet	Page 126 of 126	

APPENDIX A: SAR TEST DATA

PCTEST ENGINEERING LABORATORY, INC.

DUT: A3LSMT867U; Type: Portable Tablet; Serial: 09911

Communication System: UID 0, UMTS; Frequency: 826.4 MHz; Duty Cycle: 1:1
Medium: 835 Body; Medium parameters used (interpolated):
 $f = 826.4 \text{ MHz}$; $\sigma = 0.978 \text{ S/m}$; $\epsilon_r = 54.473$; $\rho = 1000 \text{ kg/m}^3$
Phantom section: Flat Section; Space: 0.0 cm

Test Date: 08-05-2019; Ambient Temp: 20.5°C; Tissue Temp: 19.7°C

Probe: EX3DV4 - SN7538; ConvF(9.85, 9.85, 9.85) @ 826.4 MHz; Calibrated: 5/16/2019
Sensor-Surface: 1.4mm (Mechanical Surface Detection)
Electronics: DAE4 Sn728; Calibrated: 5/8/2019
Phantom: Left Twin-SAM V5.0 30; Type: QD 000 P40 CD; Serial: 1792
Measurement SW: DASY52, Version 52.10 (2);SEMCAD X Version 14.6.12 (7470)

Mode: UMTS 850, Body SAR, Back side, Low.ch

Area Scan (15x19x1): Measurement grid: dx=15mm, dy=15mm

Zoom Scan (5x5x7)/Cube 0: Measurement grid: dx=8mm, dy=8mm, dz=5mm

Reference Value = 30.88 V/m; Power Drift = 0.00 dB

Peak SAR (extrapolated) = 3.07 W/kg

SAR(1 g) = 1.01 W/kg

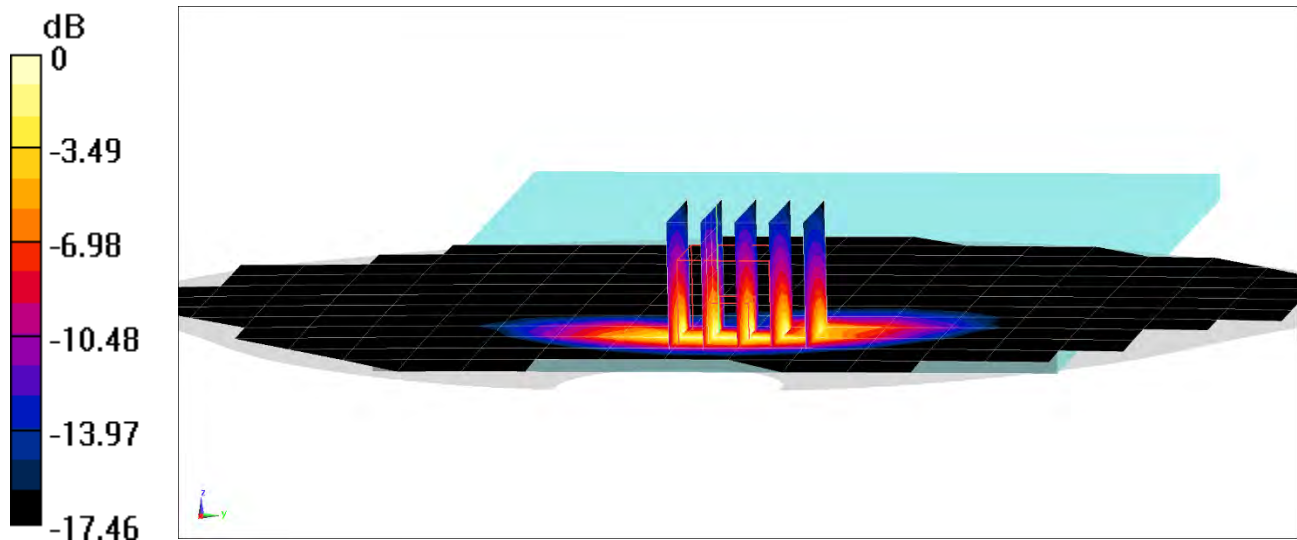

0 dB = 1.24 W/kg = 0.93 dBW/kg

PCTEST ENGINEERING LABORATORY, INC.

DUT: A3LSMT867U; Type: Portable Tablet; Serial: 11354

Communication System: UID 0, UMTS; Frequency: 1752.6 MHz; Duty Cycle: 1:1
Medium: 1750 Body; Medium parameters used (interpolated):
 $f = 1752.6 \text{ MHz}$; $\sigma = 1.439 \text{ S/m}$; $\epsilon_r = 55.119$; $\rho = 1000 \text{ kg/m}^3$
Phantom section: Flat Section; Space: 0.0 cm

Test Date: 08-13-2019; Ambient Temp: 23.2°C; Tissue Temp: 22.5°C

Probe: EX3DV4 - SN7406; ConvF(8.13, 8.13, 8.13) @ 1752.6 MHz; Calibrated: 5/16/2019
Sensor-Surface: 1.4mm (Mechanical Surface Detection)
Electronics: DAE4 Sn859; Calibrated: 5/8/2019
Phantom: Twin-SAM V5.0 Left 30; Type: QD 000 P40 CD; Serial: 1715
Measurement SW: DASY52, Version 52.10 (2);SEMCAD X Version 14.6.12 (7470)

Mode: UMTS 1750, Body SAR, Back side, High.ch

Area Scan (15x19x1): Measurement grid: dx=15mm, dy=15mm

Zoom Scan (5x5x7)/Cube 0: Measurement grid: dx=8mm, dy=8mm, dz=5mm

Reference Value = 29.71 V/m; Power Drift = -0.03 dB

Peak SAR (extrapolated) = 2.32 W/kg

SAR(1 g) = 0.986 W/kg

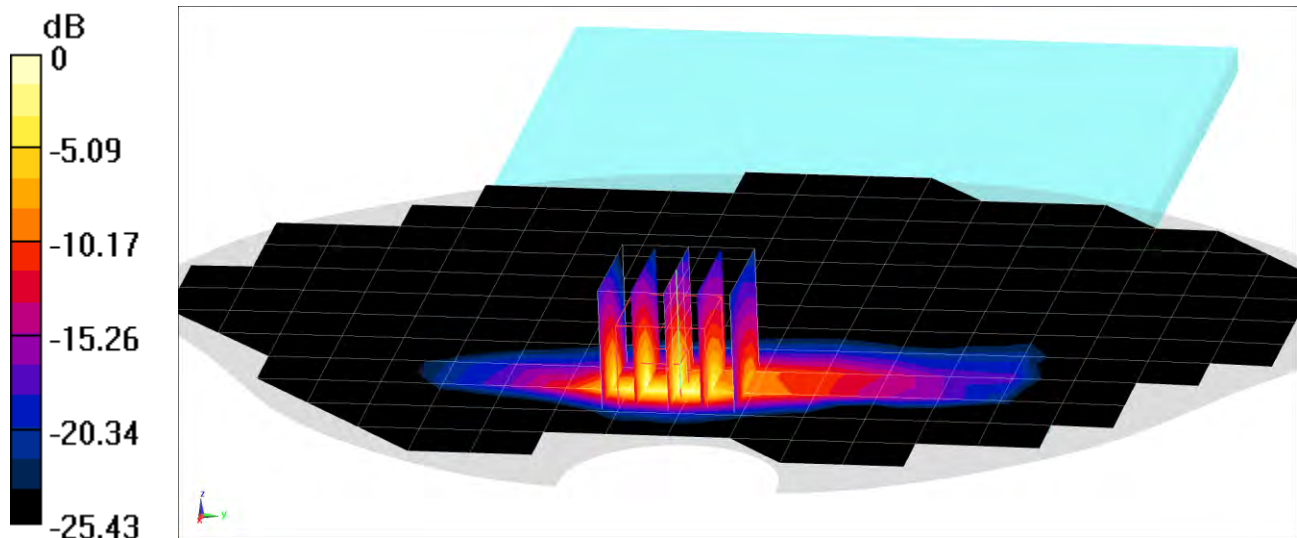

0 dB = 2.03 W/kg = 3.07 dBW/kg

PCTEST ENGINEERING LABORATORY, INC.

DUT: A3LSMT867U; Type: Portable Tablet; Serial: 10091

Communication System: UID 0, UMTS; Frequency: 1907.6 MHz; Duty Cycle: 1:1
Medium: 1900 Body; Medium parameters used (interpolated):
 $f = 1907.6$ MHz; $\sigma = 1.542$ S/m; $\epsilon_r = 51.426$; $\rho = 1000$ kg/m³
Phantom section: Flat Section; Space: 0.0 cm

Test Date: 08-07-2019; Ambient Temp: 20.3°C; Tissue Temp: 22.2°C

Probe: EX3DV4 - SN7488; ConvF(8.37, 8.37, 8.37) @ 1907.6 MHz; Calibrated: 1/24/2019
Sensor-Surface: 1.4mm (Mechanical Surface Detection)
Electronics: DAE4 Sn1530; Calibrated: 1/15/2019
Phantom: Twin-SAM V5.0; Type: QD 000 P40 CD; Serial: 1800
Measurement SW: DASY52, Version 52.10 (2);SEMCAD X Version 14.6.12 (7470)

Mode: UMTS 1900, Body SAR, Back side, High.ch

Area Scan (15x19x1): Measurement grid: dx=15mm, dy=15mm

Zoom Scan (5x5x7)/Cube 0: Measurement grid: dx=8mm, dy=8mm, dz=5mm

Reference Value = 24.00 V/m; Power Drift = 0.00 dB

Peak SAR (extrapolated) = 2.06 W/kg

SAR(1 g) = 0.816 W/kg

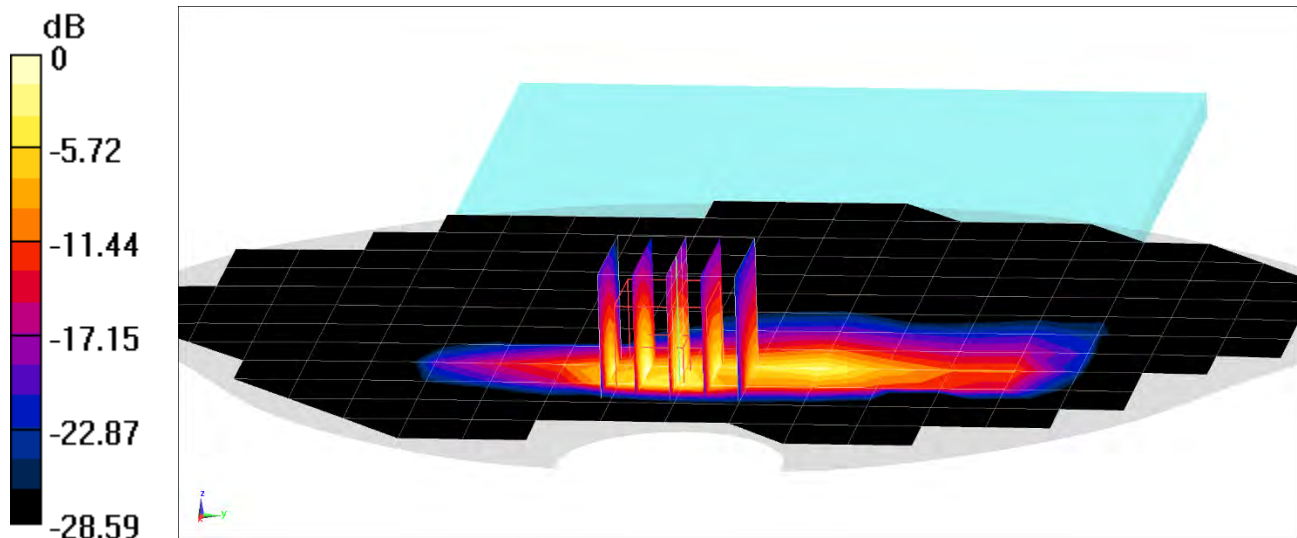

0 dB = 1.28 W/kg = 1.07 dBW/kg

PCTEST ENGINEERING LABORATORY, INC.

DUT: A3LSMT867U; Type: Portable Tablet; Serial: 11388

Communication System: UID 0, LTE Band 71; Frequency: 680.5 MHz; Duty Cycle: 1:1
Medium: 750 Body; Medium parameters used (interpolated):
 $f = 680.5 \text{ MHz}$; $\sigma = 0.925 \text{ S/m}$; $\epsilon_r = 54.069$; $\rho = 1000 \text{ kg/m}^3$
Phantom section: Flat Section; Space: 0.0 cm

Test Date: 08-12-2019; Ambient Temp: 22.0°C; Tissue Temp: 21.1°C

Probe: EX3DV4 - SN7409; ConvF(9.96, 9.96, 9.96) @ 680.5 MHz; Calibrated: 6/19/2019
Sensor-Surface: 1.4mm (Mechanical Surface Detection)
Electronics: DAE4 Sn1334; Calibrated: 6/20/2019
Phantom: Front; Type: QD 000 P40 CD; Serial: 1686
Measurement SW: DASY52, Version 52.10 (2);SEMCAD X Version 14.6.12 (7470)

**Mode: LTE Band 71, Body SAR, Top Edge, Mid.ch,
20 MHz Bandwidth, QPSK, 50 RB, 0 RB Offset**

Area Scan (11x15x1): Measurement grid: dx=5mm, dy=15mm
Zoom Scan (5x5x7)/Cube 0: Measurement grid: dx=8mm, dy=8mm, dz=5mm
Reference Value = 25.36 V/m; Power Drift = -0.16 dB
Peak SAR (extrapolated) = 2.41 W/kg
SAR(1 g) = 0.591 W/kg

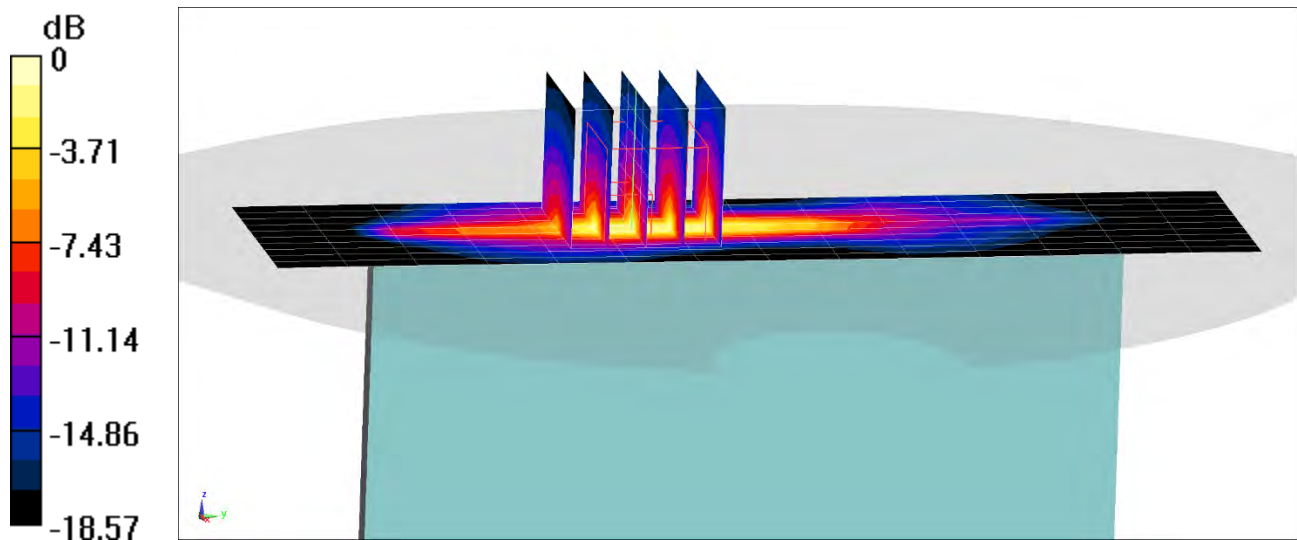

0 dB = 1.57 W/kg = 1.96 dBW/kg

PCTEST ENGINEERING LABORATORY, INC.

DUT: A3LSMT867U; Type: Portable Tablet; Serial: 11388

Communication System: UID 0, LTE Band 12; Frequency: 707.5 MHz; Duty Cycle: 1:1
Medium: 750 Body; Medium parameters used (interpolated):
 $f = 707.5 \text{ MHz}$; $\sigma = 0.935 \text{ S/m}$; $\epsilon_r = 53.996$; $\rho = 1000 \text{ kg/m}^3$
Phantom section: Flat Section; Space: 0.0 cm

Test Date: 08-12-2019; Ambient Temp: 22.0°C; Tissue Temp: 21.1°C

Probe: EX3DV4 - SN7409; ConvF(9.96, 9.96, 9.96) @ 707.5 MHz; Calibrated: 6/19/2019
Sensor-Surface: 1.4mm (Mechanical Surface Detection)
Electronics: DAE4 Sn1334; Calibrated: 6/20/2019
Phantom: Front; Type: QD 000 P40 CD; Serial: 1686
Measurement SW: DASY52, Version 52.10 (2); SEMCAD X Version 14.6.12 (7470)

**Mode: LTE Band 12, Body SAR, Top Edge, Mid.ch,
10 MHz Bandwidth, QPSK, 50 RB, 0 RB Offset**

Area Scan (11x15x1): Measurement grid: dx=5mm, dy=15mm
Zoom Scan (5x7x7)/Cube 0: Measurement grid: dx=8mm, dy=8mm, dz=5mm
Reference Value = 28.69 V/m; Power Drift = -0.06 dB
Peak SAR (extrapolated) = 3.13 W/kg
SAR(1 g) = 0.754 W/kg

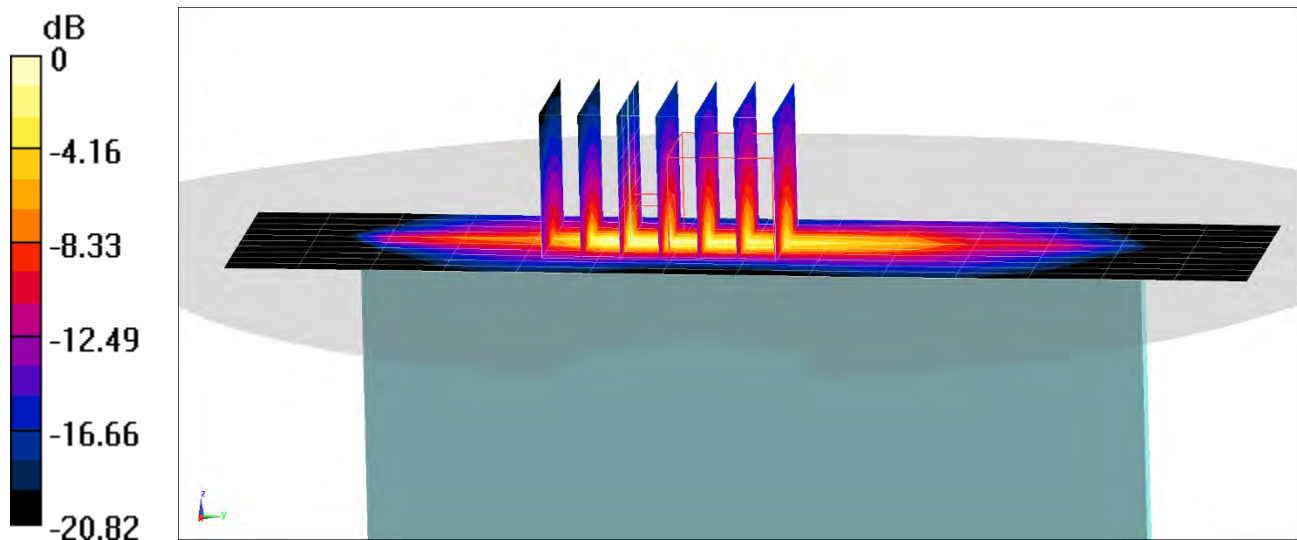

0 dB = 2.08 W/kg = 3.18 dBW/kg

PCTEST ENGINEERING LABORATORY, INC.

DUT: A3LSMT867U; Type: Portable Tablet; Serial: 11388

Communication System: UID 0, LTE Band 13; Frequency: 782 MHz; Duty Cycle: 1:1
Medium: 750 Body; Medium parameters used (interpolated):
 $f = 782 \text{ MHz}$; $\sigma = 0.963 \text{ S/m}$; $\epsilon_r = 53.819$; $\rho = 1000 \text{ kg/m}^3$
Phantom section: Flat Section; Space: 0.0 cm

Test Date: 08-12-2019; Ambient Temp: 22.0°C; Tissue Temp: 21.1°C

Probe: EX3DV4 - SN7409; ConvF(9.96, 9.96, 9.96) @ 782 MHz; Calibrated: 6/19/2019
Sensor-Surface: 1.4mm (Mechanical Surface Detection)
Electronics: DAE4 Sn1334; Calibrated: 6/20/2019
Phantom: Front; Type: QD 000 P40 CD; Serial: 1686
Measurement SW: DASY52, Version 52.10 (2);SEMCAD X Version 14.6.12 (7470)

**Mode: LTE Band 13, Body SAR, Back side, Mid.ch,
10 MHz Bandwidth, QPSK, 50 RB, 0 RB Offset**

Area Scan (9x15x1): Measurement grid: dx=15mm, dy=15mm
Zoom Scan (5x5x7)/Cube 0: Measurement grid: dx=8mm, dy=8mm, dz=5mm
Reference Value = 31.65 V/m; Power Drift = 0.00 dB
Peak SAR (extrapolated) = 3.21 W/kg
SAR(1 g) = 1.07 W/kg

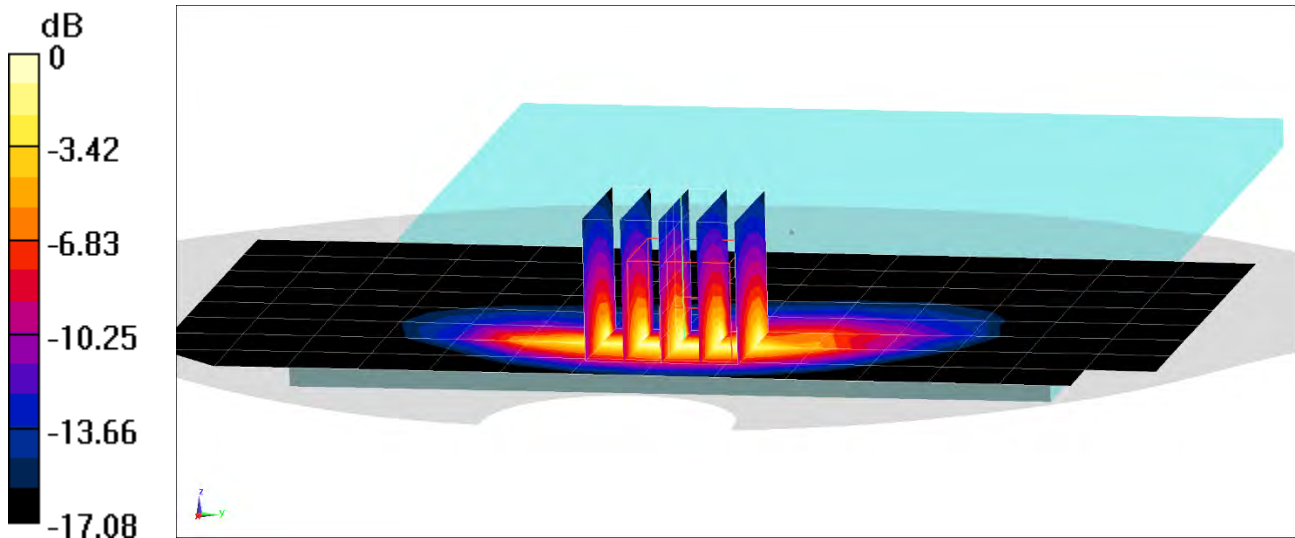

0 dB = 1.81 W/kg = 2.58 dBW/kg

PCTEST ENGINEERING LABORATORY, INC.

DUT: A3LSMT867U; Type: Portable Tablet; Serial: 09911

Communication System: UID 0, LTE Band 26; Frequency: 831.5 MHz; Duty Cycle: 1:1
Medium: 835 Body; Medium parameters used (interpolated):
 $f = 831.5 \text{ MHz}$; $\sigma = 0.969 \text{ S/m}$; $\epsilon_r = 53.481$; $\rho = 1000 \text{ kg/m}^3$
Phantom section: Flat Section; Space: 0.0 cm

Test Date: 08-12-2019; Ambient Temp: 20.5°C; Tissue Temp: 19.8°C

Probe: EX3DV4 - SN7538; ConvF(9.85, 9.85, 9.85) @ 831.5 MHz; Calibrated: 5/16/2019
Sensor-Surface: 1.4mm (Mechanical Surface Detection)
Electronics: DAE4 Sn728; Calibrated: 5/8/2019
Phantom: Left Twin-SAM V5.0 30; Type: QD 000 P40 CD; Serial: 1792
Measurement SW: DASY52, Version 52.10 (2);SEMCAD X Version 14.6.12 (7470)

**Mode: LTE Band 26 (Cell.), Body SAR, Top Edge, Mid.ch,
15 MHz Bandwidth, QPSK, 1 RB, 0 RB Offset**

Area Scan (10x13x1): Measurement grid: dx=5mm, dy=15mm
Zoom Scan (5x9x7)/Cube 0: Measurement grid: dx=8mm, dy=8mm, dz=5mm
Reference Value = 23.10 V/m; Power Drift = -0.05 dB
Peak SAR (extrapolated) = 2.12 W/kg
SAR(1 g) = 0.910 W/kg

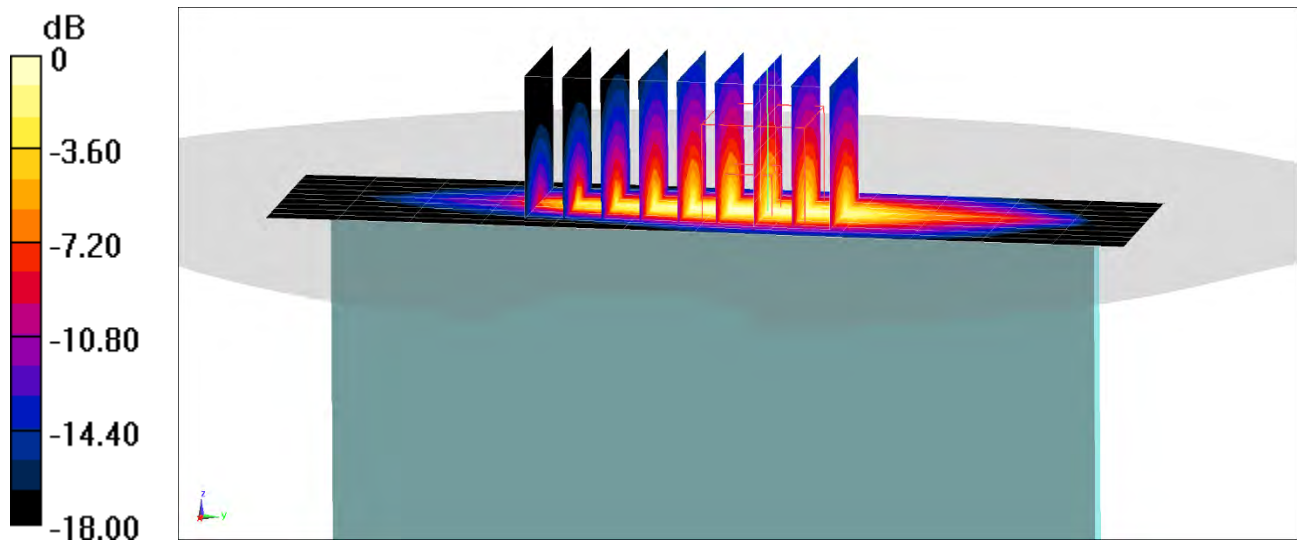

0 dB = 1.69 W/kg = 2.28 dBW/kg

PCTEST ENGINEERING LABORATORY, INC.

DUT: A3LSMT867U; Type: Portable Tablet; Serial: 04724

Communication System: UID 0, LTE Band 66 (AWS); Frequency: 1720 MHz; Duty Cycle: 1:1
Medium: 1750 Body Medium parameters used (interpolated):
 $f = 1720 \text{ MHz}$; $\sigma = 1.464 \text{ S/m}$; $\epsilon_r = 53.092$; $\rho = 1000 \text{ kg/m}^3$
Phantom section: Flat Section; Space: 0.0 cm

Test Date: 08-07-2019; Ambient Temp: 22.0°C; Tissue Temp: 21.1°C

Probe: EX3DV4 - SN7409; ConvF(7.85, 7.85, 7.85) @ 1720 MHz; Calibrated: 6/19/2019
Sensor-Surface: 1.4mm (Mechanical Surface Detection)
Electronics: DAE4 Sn1334; Calibrated: 6/20/2019
Phantom: Front; Type: QD 000 P40 CD; Serial: 1686
Measurement SW: DASY52, Version 52.10 (2);SEMCAD X Version 14.6.12 (7470)

**Mode: LTE Band 66 (AWS), Body SAR, Back side, Low.ch,
20 MHz Bandwidth, QPSK, 50 RB, 0 RB Offset**

Area Scan (15x17x1): Measurement grid: dx=15mm, dy=15mm
Zoom Scan (5x5x7)/Cube 0: Measurement grid: dx=8mm, dy=8mm, dz=5mm
Reference Value = 29.69 V/m; Power Drift = -0.01 dB
Peak SAR (extrapolated) = 2.54 W/kg
SAR(1 g) = 1.000 W/kg

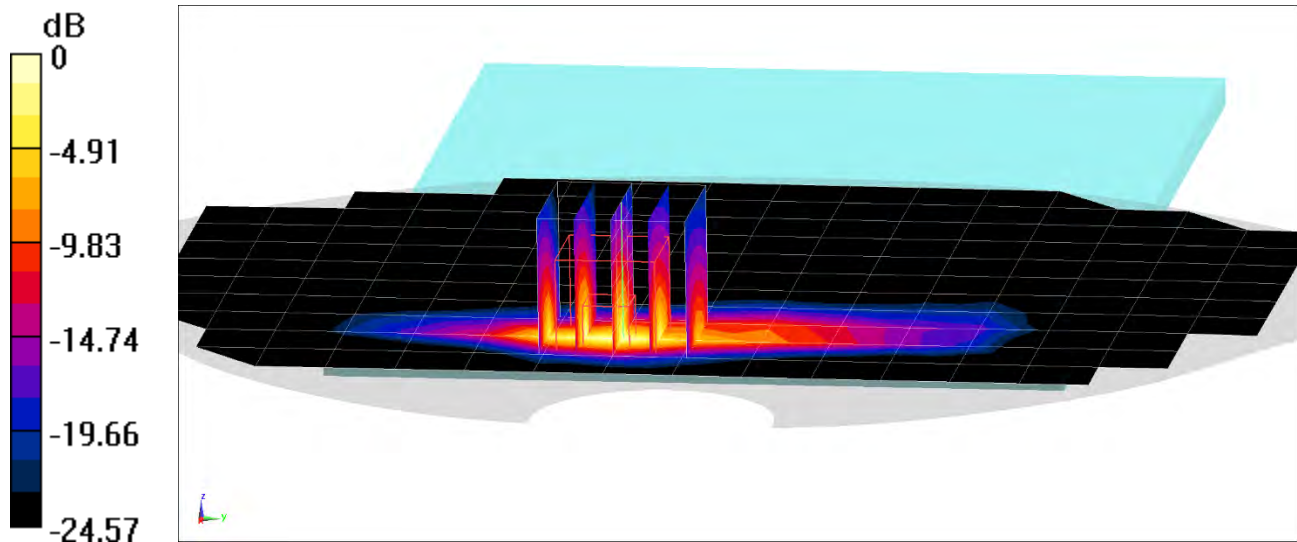

0 dB = 2.20 W/kg = 3.42 dBW/kg

PCTEST ENGINEERING LABORATORY, INC.

DUT: A3LSMT867U; Type: Portable Tablet; Serial: 10091

Communication System: UID 0, LTE Band 2 (PCS); Frequency: 1880 MHz; Duty Cycle: 1:1

Medium: 1900 Body Medium parameters used:

$f = 1880$ MHz; $\sigma = 1.543$ S/m; $\epsilon_r = 51.278$; $\rho = 1000$ kg/m³

Phantom section: Flat Section; Space: 0.0 cm

Test Date: 08-27-2019; Ambient Temp: 24.8°C; Tissue Temp: 20.6°C

Probe: EX3DV4 - SN7409; ConvF(7.67, 7.67, 7.67) @ 1880 MHz; Calibrated: 6/19/2019

Sensor-Surface: 1.4mm (Mechanical Surface Detection)

Electronics: DAE4 Sn1334; Calibrated: 6/20/2019

Phantom: Front; Type: QD 000 P40 CD; Serial: 1686

Measurement SW: DASY52, Version 52.10 (2);SEMCAD X Version 14.6.12 (7470)

**Mode: LTE Band 2 (PCS), Body SAR, Back side, Mid.ch,
20 MHz Bandwidth, QPSK, 50 RB, 0 RB Offset**

Area Scan (9x15x1): Measurement grid: dx=15mm, dy=15mm

Zoom Scan (5x5x7)/Cube 0: Measurement grid: dx=8mm, dy=8mm, dz=5mm

Reference Value = 27.57 V/m; Power Drift = -0.03 dB

Peak SAR (extrapolated) = 2.38 W/kg

SAR(1 g) = 0.877 W/kg

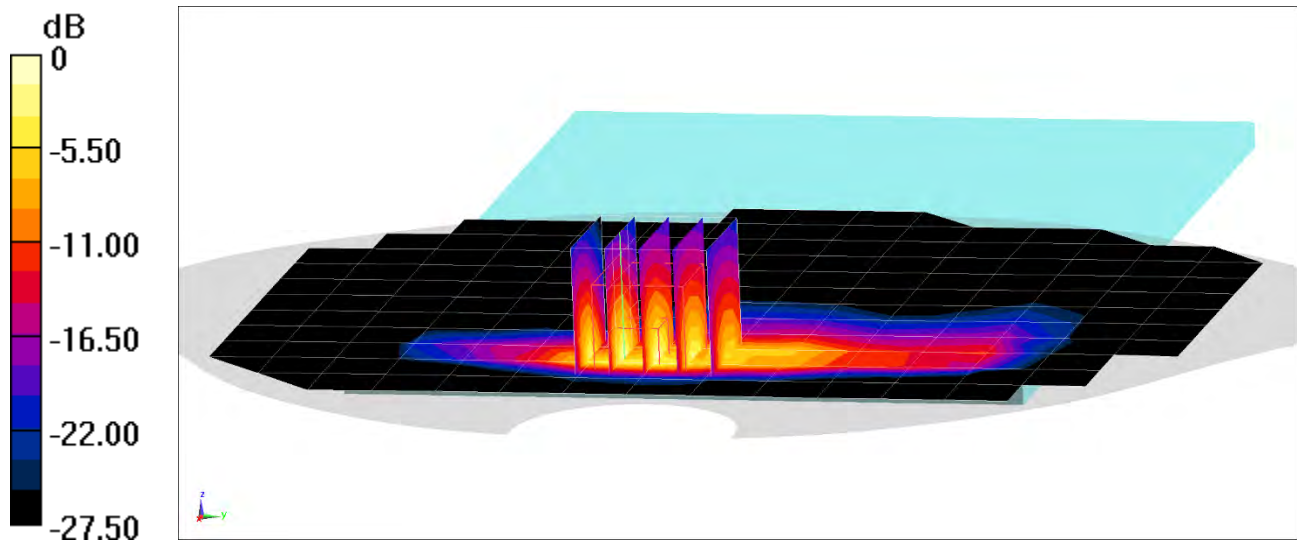

0 dB = 1.50 W/kg = 1.76 dBW/kg

PCTEST ENGINEERING LABORATORY, INC.

DUT: A3LSMT867U; Type: Portable Tablet; Serial: 10091

Communication System: UID 0, LTE Band 25 (PCS); Frequency: 1905 MHz; Duty Cycle: 1:1
Medium: 1900 Body Medium parameters used (interpolated):
 $f = 1905 \text{ MHz}$; $\sigma = 1.563 \text{ S/m}$; $\epsilon_r = 51.206$; $\rho = 1000 \text{ kg/m}^3$
Phantom section: Flat Section; Space: 0.0 cm

Test Date: 08-27-2019; Ambient Temp: 24.8°C; Tissue Temp: 20.6°C

Probe: EX3DV4 - SN7409; ConvF(7.67, 7.67, 7.67) @ 1905 MHz; Calibrated: 6/19/2019
Sensor-Surface: 1.4mm (Mechanical Surface Detection)
Electronics: DAE4 Sn1334; Calibrated: 6/20/2019
Phantom: Front; Type: QD 000 P40 CD; Serial: 1686
Measurement SW: DASY52, Version 52.10 (2); SEMCAD X Version 14.6.12 (7470)

**Mode: LTE Band 25 (PCS), Body SAR, Back side, High.ch,
20 MHz Bandwidth, QPSK, 50 RB, 0 RB Offset**

Area Scan (9x15x1): Measurement grid: dx=15mm, dy=15mm

Zoom Scan (5x5x7)/Cube 0: Measurement grid: dx=8mm, dy=8mm, dz=5mm

Reference Value = 27.14 V/m; Power Drift = 0.00 dB

Peak SAR (extrapolated) = 2.89 W/kg

SAR(1 g) = 0.994 W/kg

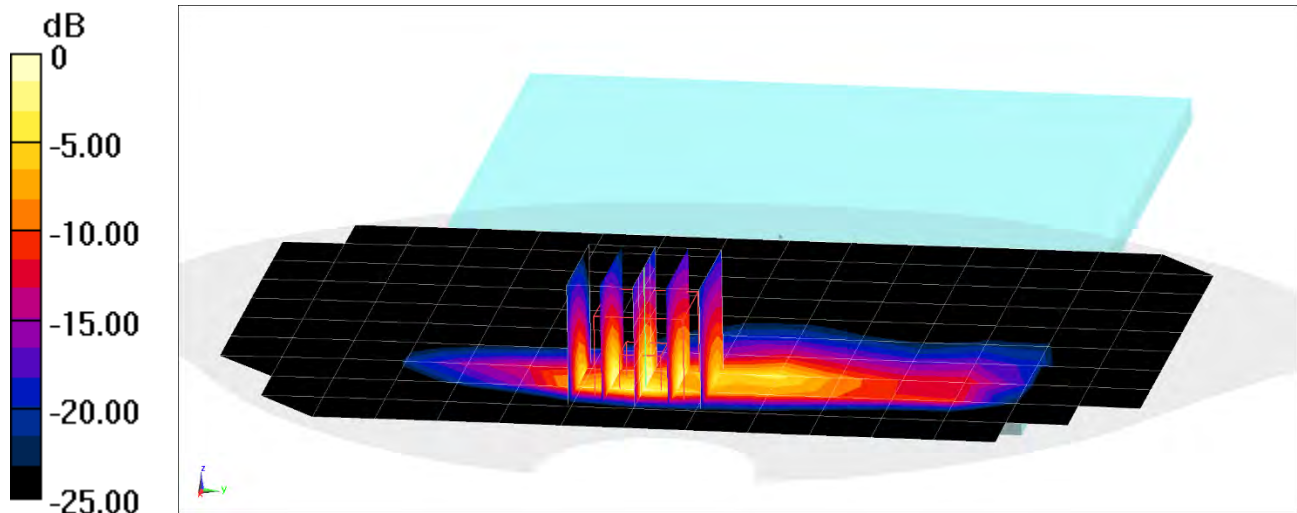

0 dB = 1.33 W/kg = 1.24 dBW/kg

PCTEST ENGINEERING LABORATORY, INC.

DUT: A3LSMT867U; Type: Portable Tablet; Serial: 11354

Communication System: UID 0, LTE Band 7; Frequency: 2510 MHz; Duty Cycle: 1:1
Medium: 2450 Body; Medium parameters used (interpolated):
 $f = 2510 \text{ MHz}$; $\sigma = 2.123 \text{ S/m}$; $\epsilon_r = 51.519$; $\rho = 1000 \text{ kg/m}^3$
Phantom section: Flat Section; Space: 0.0 cm

Test Date: 08-12-2019; Ambient Temp: 22.9°C; Tissue Temp: 22.0°C

Probe: EX3DV4 - SN7417; ConvF(7.51, 7.51, 7.51) @ 2510 MHz; Calibrated: 2/19/2019
Sensor-Surface: 1.4mm (Mechanical Surface Detection)
Electronics: DAE4 Sn665; Calibrated: 2/13/2019
Phantom: LeftTwin-SAM V5.0; Type: QD 000 P40 CD; Serial: TP1375
Measurement SW: DASY52, Version 52.10 (2);SEMCAD X Version 14.6.12 (7470)

**Mode: LTE Band 7, Body SAR, Top Edge, Low.ch,
20 MHz Bandwidth, QPSK, 50 RB, 0 RB Offset**

Area Scan (10x17x1): Measurement grid: dx=5mm, dy=12mm
Zoom Scan (7x7x7)/Cube 0: Measurement grid: dx=5mm, dy=5mm, dz=5mm
Reference Value = 24.65 V/m; Power Drift = -0.11 dB
Peak SAR (extrapolated) = 3.78 W/kg
SAR(1 g) = 1.02 W/kg

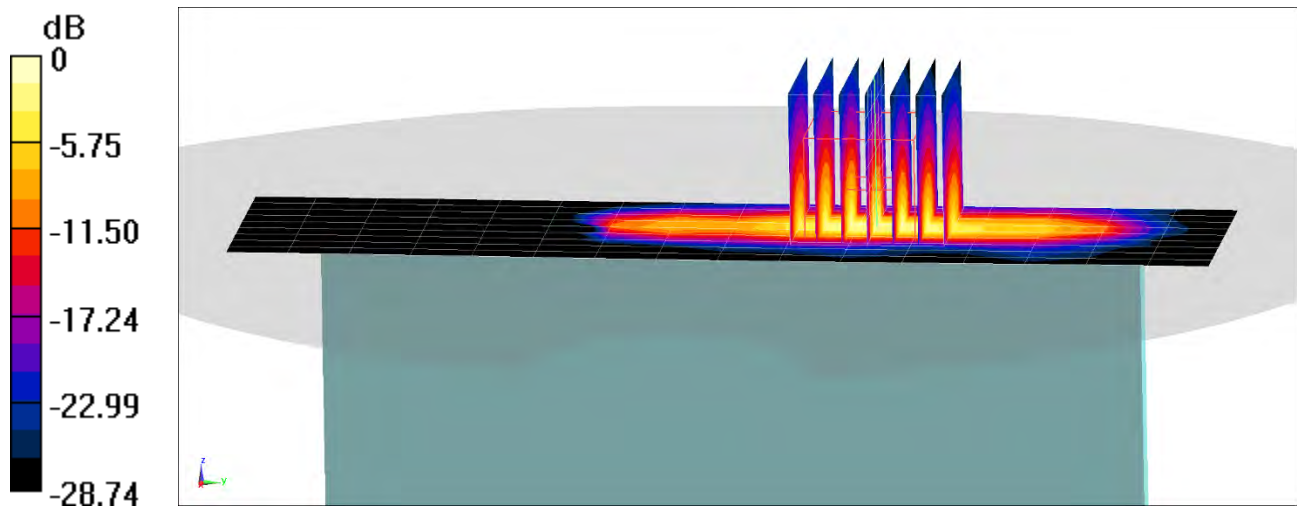

0 dB = 2.58 W/kg = 4.12 dBW/kg

PCTEST ENGINEERING LABORATORY, INC.

DUT: A3LSMT867U; Type: Portable Tablet; Serial: 09911

Communication System: UID 0, LTE Band 41; Frequency: 2593 MHz; Duty Cycle: 1:1.58
Medium: 2450 Body; Medium parameters used (interpolated):
 $f = 2593 \text{ MHz}$; $\sigma = 2.216 \text{ S/m}$; $\epsilon_r = 51.112$; $\rho = 1000 \text{ kg/m}^3$
Phantom section: Flat Section; Space: 0.0 cm

Test Date: 08-19-2019; Ambient Temp: 21.6°C; Tissue Temp: 21.0°C

Probe: EX3DV4 - SN7417; ConvF(7.37, 7.37, 7.37) @ 2593 MHz; Calibrated: 2/19/2019
Sensor-Surface: 1.4mm (Mechanical Surface Detection)
Electronics: DAE4 Sn665; Calibrated: 2/13/2019
Phantom: LeftTwin-SAM V5.0; Type: QD 000 P40 CD; Serial: TP1375
Measurement SW: DASY52, Version 52.10 (2);SEMCAD X Version 14.6.12 (7470)

Mode: LTE Band 41 (PC3) ULCA, Body SAR, Back side,
PCC: 20 MHz Bandwidth, Ch. 40620, QPSK, 1 RB, 0 RB Offset
SCC: 20 MHz Bandwidth, Ch. 40422, QPSK, 1 RB, 99 RB Offset

Area Scan (7x7x1): Measurement grid: dx=12mm, dy=12mm
Zoom Scan (7x7x7)/Cube 0: Measurement grid: dx=5mm, dy=5mm, dz=5mm
Reference Value = 18.86 V/m; Power Drift = 0.02 dB
Peak SAR (extrapolated) = 2.27 W/kg
SAR(1 g) = 0.685 W/kg

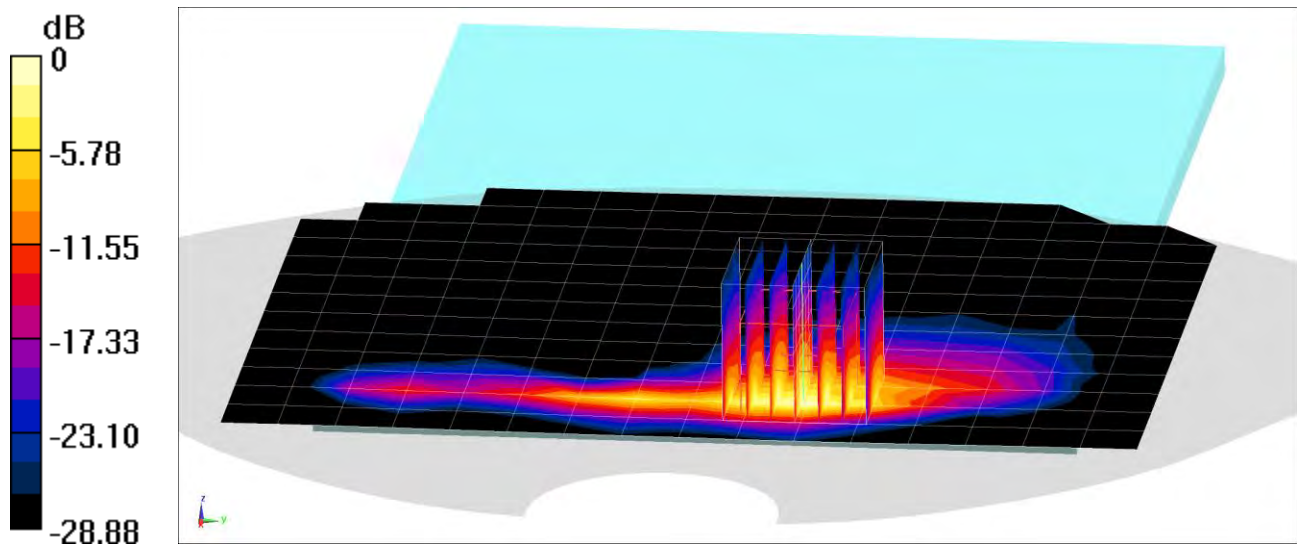

0 dB = 2.23 W/kg = 3.48 dBW/kg

PCTEST ENGINEERING LABORATORY, INC.

DUT: A3LSMT867U; Type: Portable Tablet; Serial: 09515

Communication System: UID 0, IEEE 802.11b; Frequency: 2437 MHz; Duty Cycle: 1:1
Medium: 2450 Body; Medium parameters used (interpolated):
 $f = 2437 \text{ MHz}$; $\sigma = 2.025 \text{ S/m}$; $\epsilon_r = 51.6$; $\rho = 1000 \text{ kg/m}^3$
Phantom section: Flat Section; Space: 0.0 cm

Test Date: 08-19-2019; Ambient Temp: 21.6°C; Tissue Temp: 21.0°C

Probe: EX3DV4 - SN7417; ConvF(7.51, 7.51, 7.51) @ 2437 MHz; Calibrated: 2/19/2019
Sensor-Surface: 1.4mm (Mechanical Surface Detection)
Electronics: DAE4 Sn665; Calibrated: 2/13/2019
Phantom: LeftTwin-SAM V5.0; Type: QD 000 P40 CD; Serial: TP1375
Measurement SW: DASY52, Version 52.10 (2);SEMCAD X Version 14.6.12 (7470)

**Mode: IEEE 802.11b, 22 MHz Bandwidth, Antenna 1,
Body SAR, Ch 6, 1 Mbps, Left Edge**

Area Scan (11x24x1): Measurement grid: dx=5mm, dy=12mm
Zoom Scan (7x8x7)/Cube 0: Measurement grid: dx=5mm, dy=5mm, dz=5mm
Reference Value = 22.19 V/m; Power Drift = 0.02 dB
Peak SAR (extrapolated) = 2.48 W/kg
SAR(1 g) = 0.851 W/kg

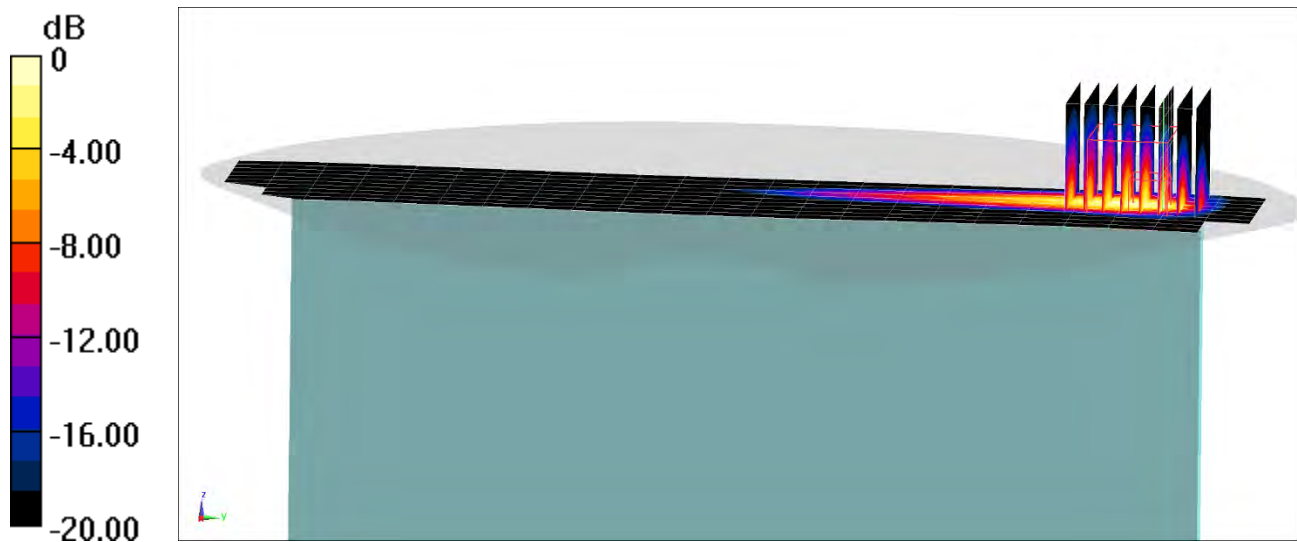

PCTEST ENGINEERING LABORATORY, INC.

DUT: A3LSMT867U; Type: Portable Tablet; Serial: 10109

Communication System: UID 0, IEEE 802.11a; Frequency: 5500 MHz; Duty Cycle: 1:1

Medium: 5GHz Body; Medium parameters used:

$f = 5500 \text{ MHz}$; $\sigma = 5.526 \text{ S/m}$; $\epsilon_r = 46.684$; $\rho = 1000 \text{ kg/m}^3$

Phantom section: Flat Section; Space: 0.8 cm

Test Date: 08-05-2019 Ambient Temp: 20.3°C; Tissue Temp: 21.1°C

Probe: EX3DV4 - SN7410; ConvF(4.42, 4.42, 4.42) @ 5500 MHz; Calibrated: 7/16/2019

Sensor-Surface: 1.4mm (Mechanical Surface Detection)

Electronics: DAE4 Sn1322; Calibrated: 7/11/2019

Phantom: Twin-SAM V5.0; Type: QD 000 P40 CD; Serial: 1630

Measurement SW: DASY52, Version 52.10 (2);SEMCAD X Version 14.6.12 (7470)

**Mode: IEEE 802.11a, U-NII-2C, 20 MHz Bandwidth, Antenna 2,
Body SAR, Ch 100, 6 Mbps, Right Edge**

Area Scan (9x29x1): Measurement grid: dx=5mm, dy=10mm

Zoom Scan (7x7x7)/Cube 0: Measurement grid: dx=4mm, dy=4mm, dz=1.4mm; Graded Ratio: 1.4

Reference Value = 14.66 V/m; Power Drift = 0.08 dB

Peak SAR (extrapolated) = 4.12 W/kg

SAR(1 g) = 1.08 W/kg

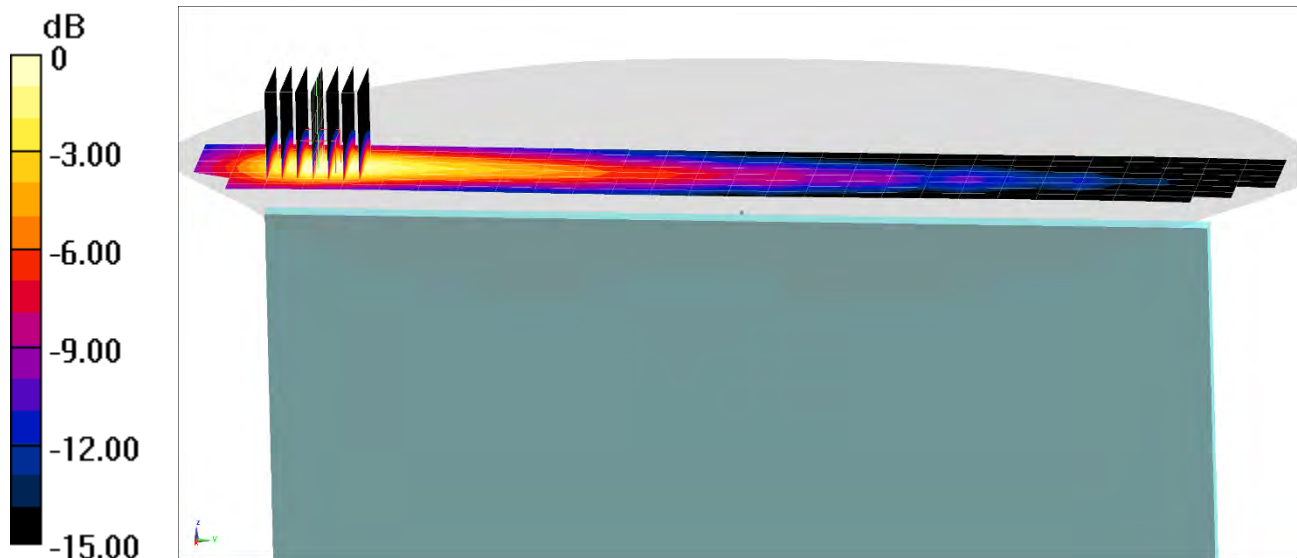

0 dB = 2.53 W/kg = 4.03 dBW/kg

PCTEST ENGINEERING LABORATORY, INC.

DUT: A3LSMT867U; Type: Portable Tablet; Serial: 11354

Communication System: UID 0, Bluetooth; Frequency: 2441 MHz; Duty Cycle: 1:1.294
Medium: 2450 Body; Medium parameters used (interpolated):
 $f = 2441 \text{ MHz}$; $\sigma = 1.928 \text{ S/m}$; $\epsilon_r = 52.523$; $\rho = 1000 \text{ kg/m}^3$
Phantom section: Flat Section; Space: 0.0 cm

Test Date: 08-07-2019; Ambient Temp: 24.9°C; Tissue Temp: 23.8°C

Probe: EX3DV4 - SN7357; ConvF(7.59, 7.59, 7.59) @ 2441 MHz; Calibrated: 4/24/2019
Sensor-Surface: 1.4mm (Mechanical Surface Detection)
Electronics: DAE4 Sn1407; Calibrated: 4/18/2019
Phantom: Twin-SAM V4.0 Front Right; Type: QD 000 P40 CC; Serial: 1167
Measurement SW: DASY52, Version 52.10 (2);SEMCAD X Version 14.6.12 (7470)

Mode: Bluetooth, Body SAR, Ch 39, 1 Mbps, Left Edge

Area Scan (11x24x1): Measurement grid: dx=5mm, dy=12mm

Zoom Scan (7x8x7)/Cube 0: Measurement grid: dx=5mm, dy=5mm, dz=5mm

Reference Value = 18.30 V/m; Power Drift = -0.10 dB

Peak SAR (extrapolated) = 2.20 W/kg

SAR(1 g) = 0.648 W/kg

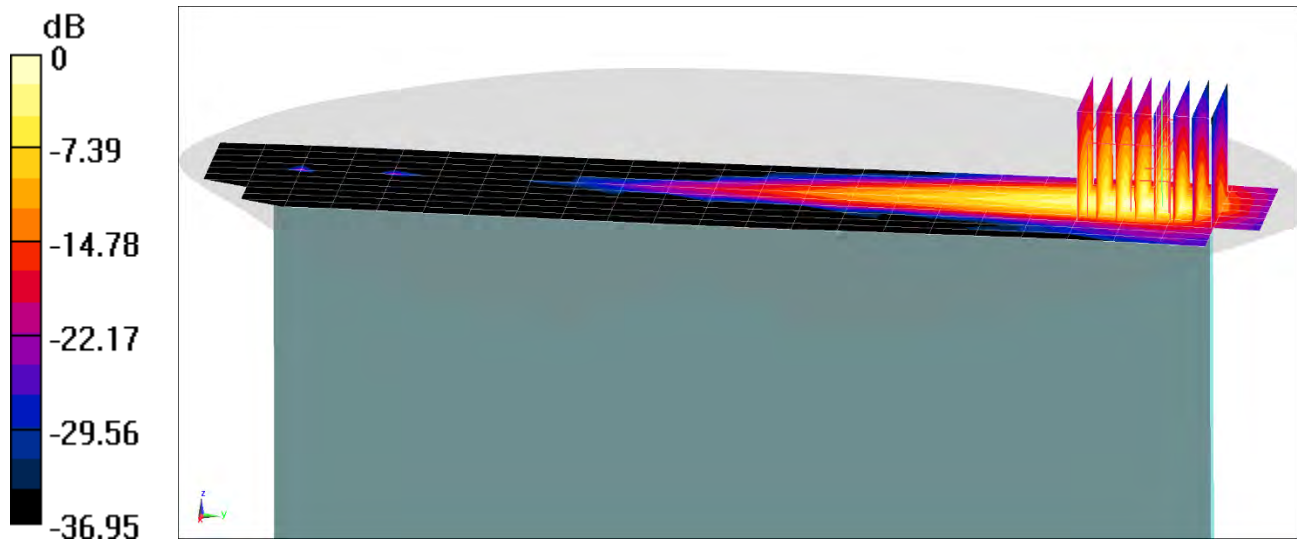

0 dB = 1.43 W/kg = 1.55 dBW/kg

APPENDIX B: SYSTEM VERIFICATION

PCTEST ENGINEERING LABORATORY, INC.

DUT: Dipole 750 MHz; Type: D750V3; Serial: 1003

Communication System: UID 0, CW; Frequency: 750 MHz; Duty Cycle: 1:1
Medium: 750 Body Medium parameters used (interpolated):
 $f = 750 \text{ MHz}$; $\sigma = 0.951 \text{ S/m}$; $\epsilon_r = 53.906$; $\rho = 1000 \text{ kg/m}^3$
Phantom section: Flat Section; Space: 1.5 cm

Test Date: 08-12-2019; Ambient Temp: 22.0°C; Tissue Temp: 21.1°C

Probe: EX3DV4 - SN7409; ConvF(9.96, 9.96, 9.96) @ 750 MHz; Calibrated: 6/19/2019
Sensor-Surface: 1.4mm (Mechanical Surface Detection)
Electronics: DAE4 Sn1334; Calibrated: 6/20/2019
Phantom: Front; Type: QD 000 P40 CD; Serial: 1686
Measurement SW: DASY52, Version 52.10 (2);SEMCAD X Version 14.6.12 (7470)

750 MHz System Verification at 23.0 dBm (200 mW)

Area Scan (7x15x1): Measurement grid: dx=15mm, dy=15mm

Zoom Scan (5x5x7)/Cube 0: Measurement grid: dx=8mm, dy=8mm, dz=5mm

Peak SAR (extrapolated) = 2.90 W/kg

SAR(1 g) = 1.8 W/kg

Deviation(1 g) = 4.90%

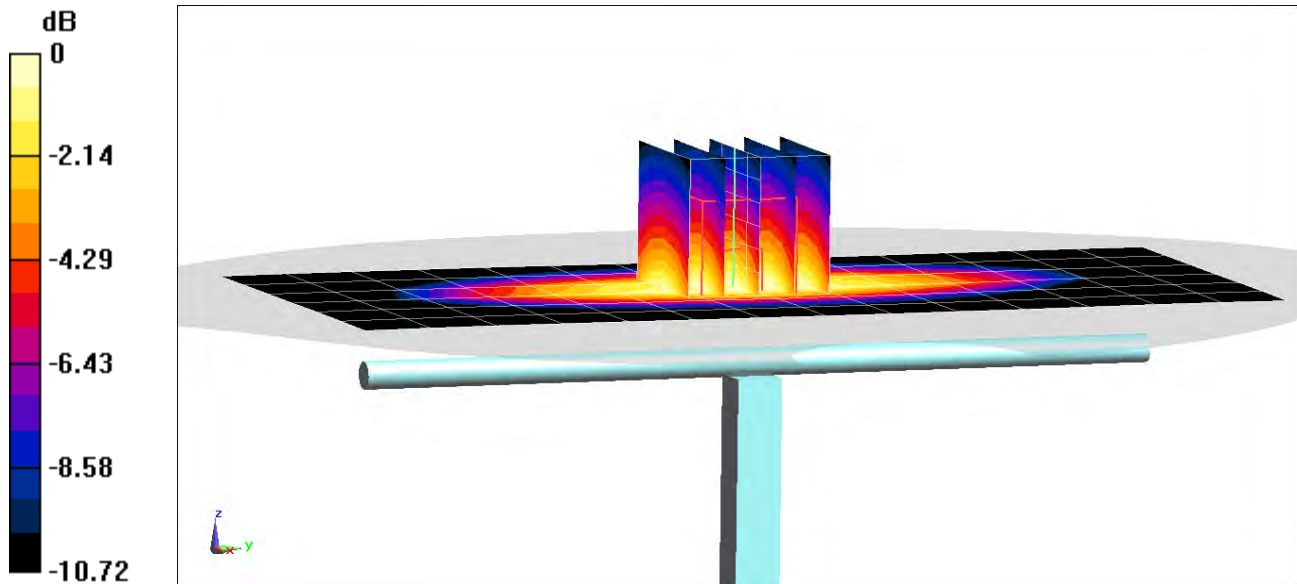

0 dB = 2.47 W/kg = 3.93 dBW/kg

PCTEST ENGINEERING LABORATORY, INC.

DUT: Dipole 835 MHz; Type: D835V2; Serial: 4d047

Communication System: UID 0, CW; Frequency: 835 MHz; Duty Cycle: 1:1

Medium: 835 Body Medium parameters used:

$f = 835 \text{ MHz}$; $\sigma = 0.983 \text{ S/m}$; $\epsilon_r = 54.443$; $\rho = 1000 \text{ kg/m}^3$

Phantom section: Flat Section; Space: 1.5 cm

Test Date: 08-05-2019; Ambient Temp: 20.5°C; Tissue Temp: 19.7°C

Probe: EX3DV4 - SN7538; ConvF(9.85, 9.85, 9.85) @ 835 MHz; Calibrated: 5/16/2019

Sensor-Surface: 1.4mm (Mechanical Surface Detection)

Electronics: DAE4 Sn728; Calibrated: 5/8/2019

Phantom: Left Twin-SAM V5.0 30; Type: QD 000 P40 CD; Serial: 1792

Measurement SW: DASY52, Version 52.10 (2);SEMCAD X Version 14.6.12 (7470)

835 MHz System Verification at 23.0 dBm (200 mW)

Area Scan (7x14x1): Measurement grid: dx=15mm, dy=15mm

Zoom Scan (5x5x7)/Cube 0: Measurement grid: dx=8mm, dy=8mm, dz=5mm

Peak SAR (extrapolated) = 3.12 W/kg

SAR(1 g) = 2.03 W/kg

Deviation(1 g) = 7.18%

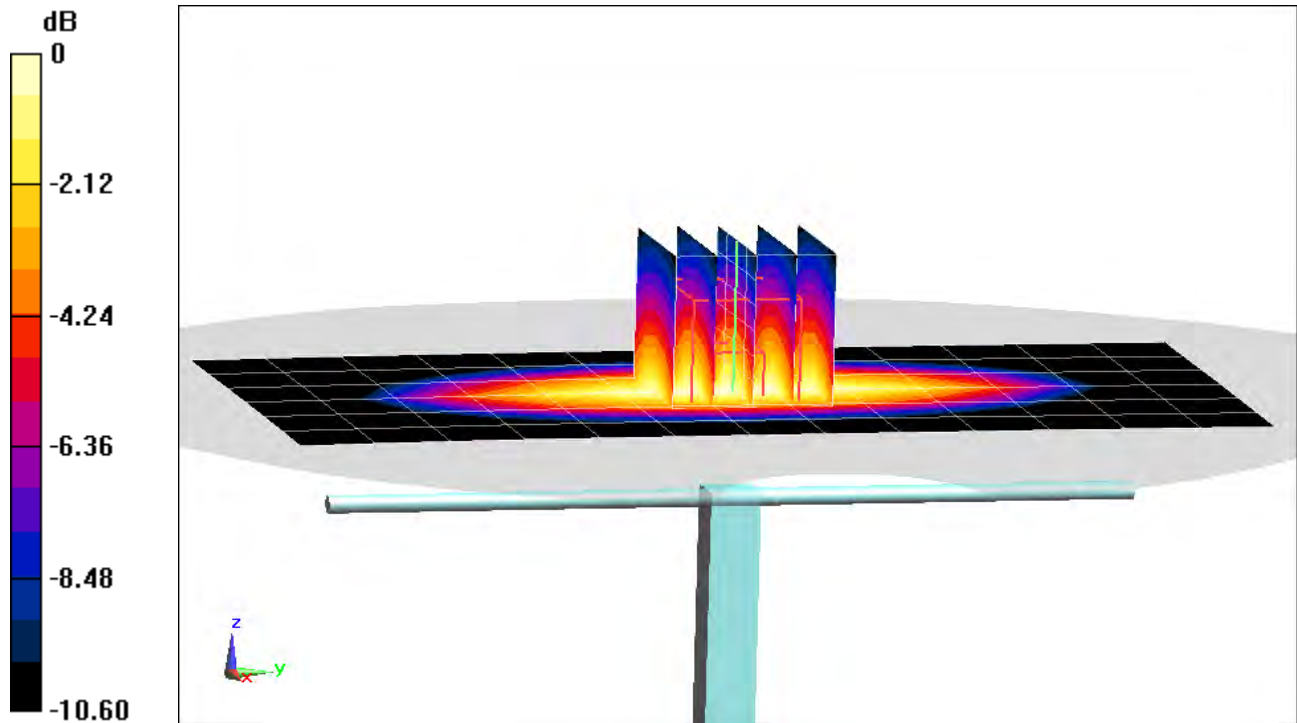

0 dB = 2.73 W/kg = 4.36 dBW/kg

PCTEST ENGINEERING LABORATORY, INC.

DUT: Dipole 835 MHz; Type: D835V2; Serial: 4d047

Communication System: UID 0, CW; Frequency: 835 MHz; Duty Cycle: 1:1

Medium: 835 Body Medium parameters used:

$f = 835 \text{ MHz}$; $\sigma = 0.972 \text{ S/m}$; $\epsilon_r = 53.443$; $\rho = 1000 \text{ kg/m}^3$

Phantom section: Flat Section; Space: 1.5 cm

Test Date: 08-12-2019; Ambient Temp: 20.5°C; Tissue Temp: 19.8°C

Probe: EX3DV4 - SN7538; ConvF(9.85, 9.85, 9.85) @ 835 MHz; Calibrated: 5/16/2019

Sensor-Surface: 1.4mm (Mechanical Surface Detection)

Electronics: DAE4 Sn728; Calibrated: 5/8/2019

Phantom: Left Twin-SAM V5.0 30; Type: QD 000 P40 CD; Serial: 1792

Measurement SW: DASY52, Version 52.10 (2);SEMCAD X Version 14.6.12 (7470)

835 MHz System Verification at 23.0 dBm (200 mW)

Area Scan (7x14x1): Measurement grid: dx=15mm, dy=15mm

Zoom Scan (5x5x7)/Cube 0: Measurement grid: dx=8mm, dy=8mm, dz=5mm

Peak SAR (extrapolated) = 3.20 W/kg

SAR(1 g) = 2.06 W/kg

Deviation(1 g) = 8.76%

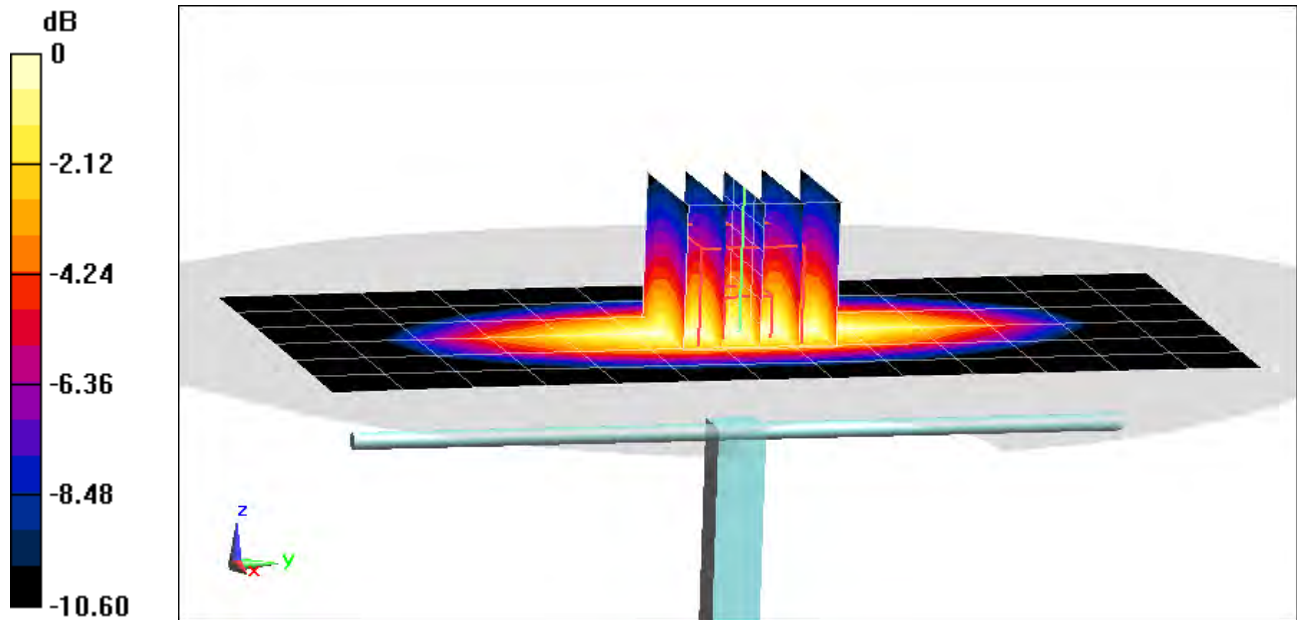

0 dB = 2.79 W/kg = 4.46 dBW/kg

PCTEST ENGINEERING LABORATORY, INC.

DUT: Dipole 1750 MHz; Type: D1750V2; Serial: 1148

Communication System: UID 0, CW; Frequency: 1750 MHz; Duty Cycle: 1:1

Medium: 1750 Body Medium parameters used:

$f = 1750 \text{ MHz}$; $\sigma = 1.486 \text{ S/m}$; $\epsilon_r = 53.046$; $\rho = 1000 \text{ kg/m}^3$

Phantom section: Flat Section; Space: 1.0 cm

Test Date: 08-07-2019; Ambient Temp: 22.0°C; Tissue Temp: 21.1°C

Probe: EX3DV4 - SN7409; ConvF(7.85, 7.85, 7.85) @ 1750 MHz; Calibrated: 6/19/2019

Sensor-Surface: 1.4mm (Mechanical Surface Detection)

Electronics: DAE4 Sn1334; Calibrated: 6/20/2019

Phantom: Front; Type: QD 000 P40 CD; Serial: 1686

Measurement SW: DASY52, Version 52.10 (2);SEMCAD X Version 14.6.12 (7470)

1750 MHz System Verification at 20.0 dBm (100 mW)

Area Scan (7x9x1): Measurement grid: dx=15mm, dy=15mm

Zoom Scan (5x5x7)/Cube 0: Measurement grid: dx=8mm, dy=8mm, dz=5mm

Peak SAR (extrapolated) = 7.60 W/kg

SAR(1 g) = 3.99 W/kg

Deviation(1 g) = 5.84%

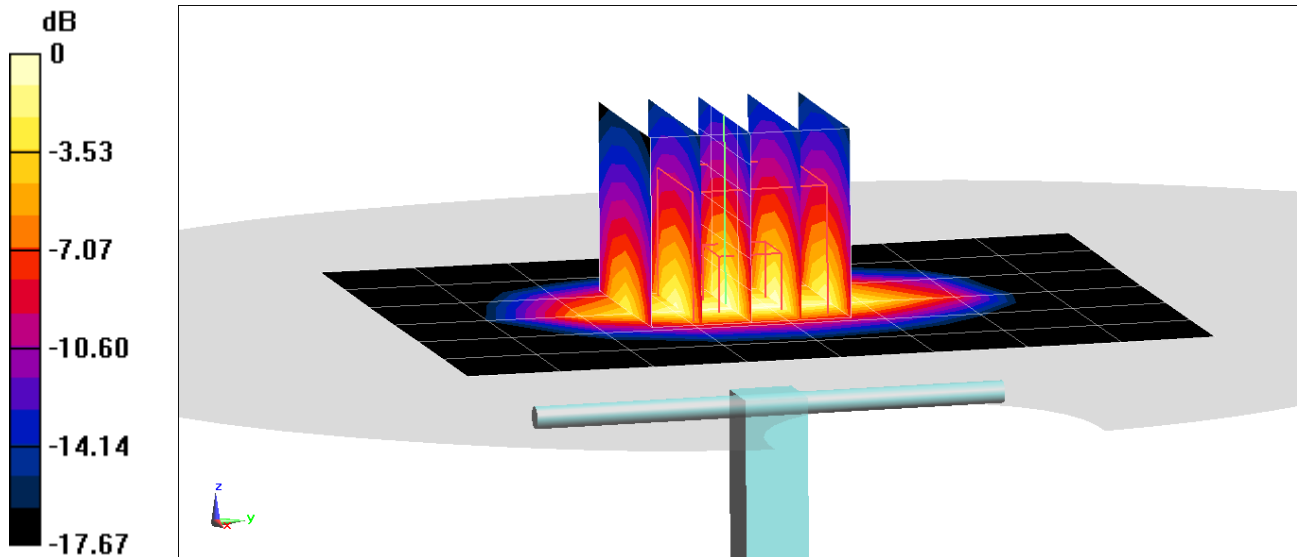

0 dB = 6.21 W/kg = 7.93 dBW/kg

PCTEST ENGINEERING LABORATORY, INC.

DUT: Dipole 1750 MHz; Type: D1765V2; Serial: 1008

Communication System: UID 0, CW; Frequency: 1750 MHz; Duty Cycle: 1:1
Medium: 1750 Body; Medium parameters used:
 $f = 1750 \text{ MHz}$; $\sigma = 1.438 \text{ S/m}$; $\epsilon_r = 55.123$; $\rho = 1000 \text{ kg/m}^3$
Phantom section: Flat Section; Space: 1.0 cm

Test Date: 08-13-2019; Ambient Temp: 23.2°C; Tissue Temp: 22.5°C

Probe: EX3DV4 - SN7406; ConvF(8.13, 8.13, 8.13) @ 1750 MHz; Calibrated: 5/16/2019
Sensor-Surface: 1.4mm (Mechanical Surface Detection)
Electronics: DAE4 Sn859; Calibrated: 5/8/2019
Phantom: Twin-SAM V5.0 Left 30; Type: QD 000 P40 CD; Serial: 1715
Measurement SW: DASY52, Version 52.10 (2);SEMCAD X Version 14.6.12 (7470)

1750 MHz System Verification at 20.0 dBm (100 mW)

Area Scan (7x9x1): Measurement grid: dx=15mm, dy=15mm
Zoom Scan (5x5x7)/Cube 0: Measurement grid: dx=8mm, dy=8mm, dz=5mm
Peak SAR (extrapolated) = 6.53 W/kg
SAR(1 g) = 3.69 W/kg
Deviation(1 g) = -1.34%

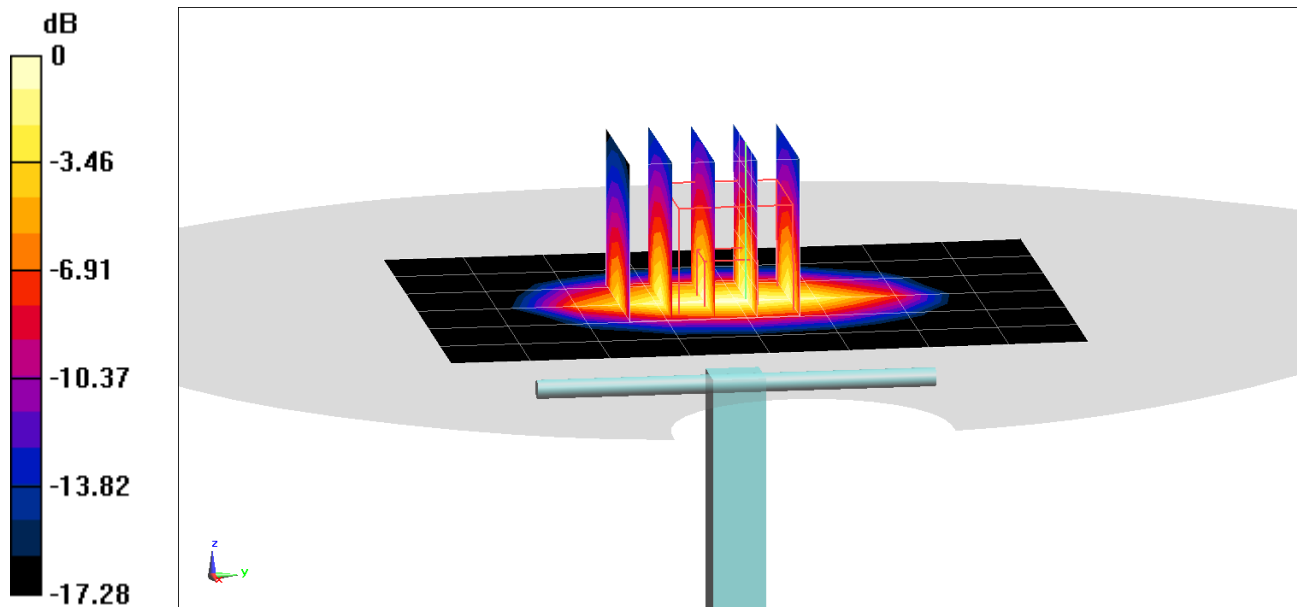

0 dB = 5.48 W/kg = 7.39 dBW/kg

PCTEST ENGINEERING LABORATORY, INC.

DUT: Dipole 1900 MHz; Type: D1900V2; Serial: 5d080

Communication System: UID 0, CW; Frequency: 1900 MHz; Duty Cycle: 1:1
Medium: 1900 Body Medium parameters used (interpolated):
 $f = 1900 \text{ MHz}$; $\sigma = 1.534 \text{ S/m}$; $\epsilon_r = 51.449$; $\rho = 1000 \text{ kg/m}^3$
Phantom section: Flat Section; Space: 1.0 cm

Test Date: 08-07-2019; Ambient Temp: 20.3°C; Tissue Temp: 22.2°C

Probe: EX3DV4 - SN7488; ConvF(8.37, 8.37, 8.37) @ 1900 MHz; Calibrated: 1/24/2019
Sensor-Surface: 1.4mm (Mechanical Surface Detection)
Electronics: DAE4 Sn1530; Calibrated: 1/15/2019
Phantom: Twin-SAM V5.0; Type: QD 000 P40 CD; Serial: 1800
Measurement SW: DASY52, Version 52.10 (2);SEMCAD X Version 14.6.12 (7470)

1900 MHz System Verification at 20.0 dBm (100 mW)

Area Scan (7x11x1): Measurement grid: dx=15mm, dy=15mm

Zoom Scan (5x5x7)/Cube 0: Measurement grid: dx=8mm, dy=8mm, dz=5mm

Peak SAR (extrapolated) = 7.78 W/kg

SAR(1 g) = 4.04 W/kg

Deviation(1 g) = 3.06%

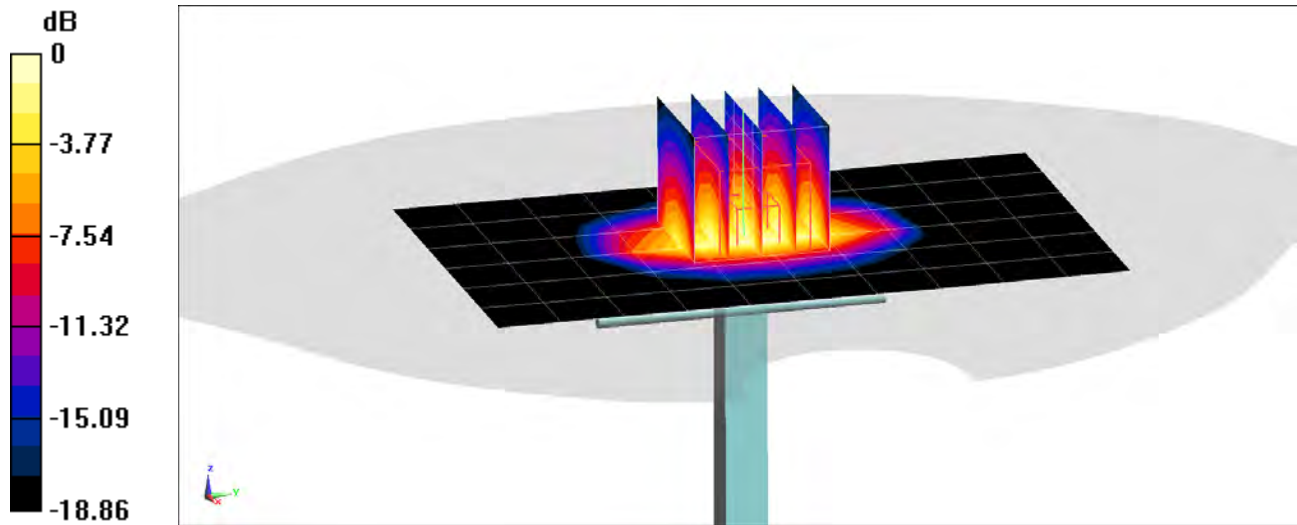

0 dB = 6.42 W/kg = 8.08 dBW/kg

PCTEST ENGINEERING LABORATORY, INC.

DUT: Dipole 1900 MHz; Type: D1900V2; Serial: 5d148

Communication System: UID 0, CW; Frequency: 1900 MHz; Duty Cycle: 1:1

Medium: 1900 Body Medium parameters used (interpolated):

$f = 1900 \text{ MHz}$; $\sigma = 1.559 \text{ S/m}$; $\epsilon_r = 51.22$; $\rho = 1000 \text{ kg/m}^3$

Phantom section: Flat Section; Space: 1.0 cm

Test Date: 08-27-2019; Ambient Temp: 24.8°C; Tissue Temp: 20.6°C

Probe: EX3DV4 - SN7409; ConvF(7.67, 7.67, 7.67) @ 1900 MHz; Calibrated: 6/19/2019

Sensor-Surface: 1.4mm (Mechanical Surface Detection)

Electronics: DAE4 Sn1334; Calibrated: 6/20/2019

Phantom: Front; Type: QD 000 P40 CD; Serial: 1686

Measurement SW: DASY52, Version 52.10 (2);SEMCAD X Version 14.6.12 (7470)

1900 MHz System Verification at 20.0 dBm (100 mW)

Area Scan (7x11x1): Measurement grid: dx=15mm, dy=15mm

Zoom Scan (5x5x7)/Cube 0: Measurement grid: dx=8mm, dy=8mm, dz=5mm

Peak SAR (extrapolated) = 7.23 W/kg

SAR(1 g) = 3.89 W/kg

Deviation(1 g) = -0.51%

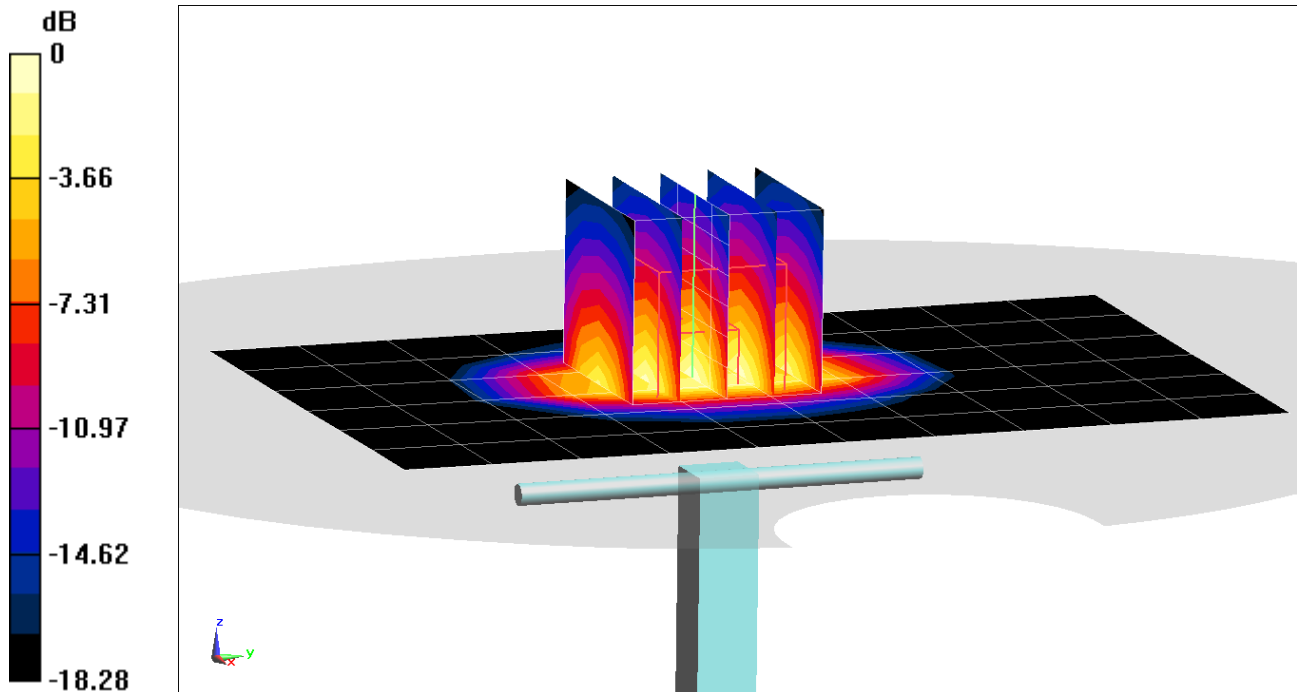

0 dB = 6.10 W/kg = 7.85 dBW/kg

PCTEST ENGINEERING LABORATORY, INC.

DUT: Dipole 2450 MHz; Type: D2450V2; Serial: 719

Communication System: UID 0, CW; Frequency: 2450 MHz; Duty Cycle: 1:1

Medium: 2450 Body; Medium parameters used:

$f = 2450 \text{ MHz}$; $\sigma = 1.94 \text{ S/m}$; $\epsilon_r = 52.495$; $\rho = 1000 \text{ kg/m}^3$

Phantom section: Flat Section; Space: 1.0 cm

Test Date: 08-07-2019; Ambient Temp: 24.9°C; Tissue Temp: 23.8°C

Probe: EX3DV4 - SN7357; ConvF(7.59, 7.59, 7.59) @ 2450 MHz; Calibrated: 4/24/2019

Sensor-Surface: 1.4mm (Mechanical Surface Detection)

Electronics: DAE4 Sn1407; Calibrated: 4/18/2019

Phantom: Twin-SAM V4.0 Front Right; Type: QD 000 P40 CC; Serial: 1167

Measurement SW: DASY52, Version 52.10 (2); SEMCAD X Version 14.6.12 (7470)

2450 MHz System Verification at 20.0 dBm (100 mW)

Area Scan (8x9x1): Measurement grid: dx=12mm, dy=12mm

Zoom Scan (7x7x7)/Cube 0: Measurement grid: dx=5mm, dy=5mm, dz=5mm

Peak SAR (extrapolated) = 11.0 W/kg

SAR(1 g) = 5.4 W/kg

Deviation(1 g) = 7.78%

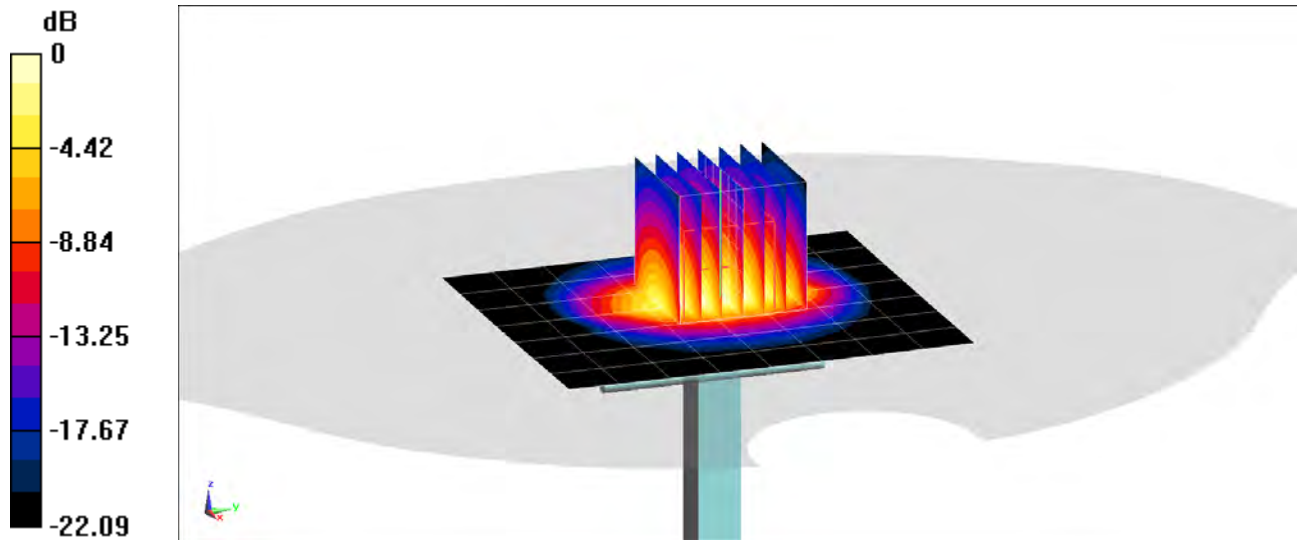

0 dB = 8.89 W/kg = 9.49 dBW/kg

PCTEST ENGINEERING LABORATORY, INC.

DUT: Dipole 2450 MHz; Type: D2450V2; Serial: 797

Communication System: UID 0, CW; Frequency: 2450 MHz; Duty Cycle: 1:1

Medium: 2450 Body; Medium parameters used:

$f = 2450 \text{ MHz}$; $\sigma = 2.046 \text{ S/m}$; $\epsilon_r = 51.692$; $\rho = 1000 \text{ kg/m}^3$

Phantom section: Flat Section; Space: 1.0 cm

Test Date: 08-12-2019; Ambient Temp: 22.9°C; Tissue Temp: 22.0°C

Probe: EX3DV4 - SN7417; ConvF(7.51, 7.51, 7.51) @ 2450 MHz; Calibrated: 2/19/2019

Sensor-Surface: 1.4mm (Mechanical Surface Detection)

Electronics: DAE4 Sn665; Calibrated: 2/13/2019

Phantom: LeftTwin-SAM V5.0; Type: QD 000 P40 CD; Serial: TP1375

Measurement SW: DASY52, Version 52.10 (2);SEMCAD X Version 14.6.12 (7470)

2450 MHz System Verification at 20.0 dBm (100 mW)

Area Scan (8x9x1): Measurement grid: dx=12mm, dy=12mm

Zoom Scan (7x7x7)/Cube 0: Measurement grid: dx=5mm, dy=5mm, dz=5mm

Peak SAR (extrapolated) = 10.4 W/kg

SAR(1 g) = 4.97 W/kg

Deviation(1 g) = -2.74%

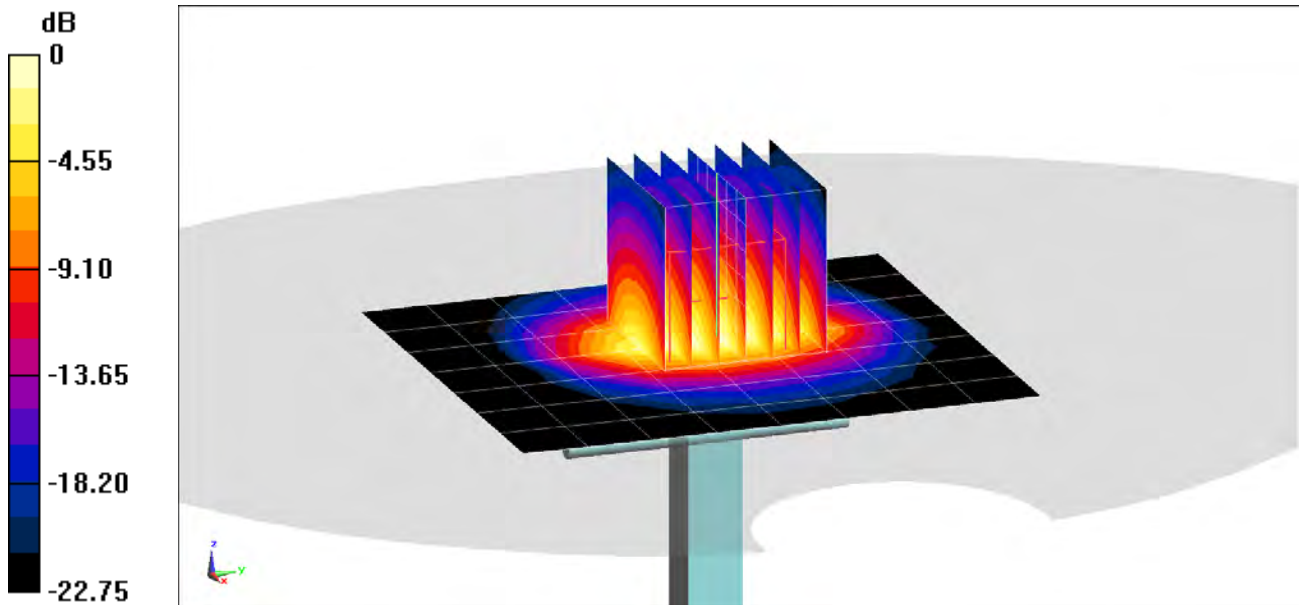

0 dB = 8.39 W/kg = 9.24 dBW/kg

PCTEST ENGINEERING LABORATORY, INC.

DUT: Dipole 2600 MHz; Type: D2600V2; Serial: 1004

Communication System: UID 0, CW; Frequency: 2600 MHz; Duty Cycle: 1:1

Medium: 2450 Body; Medium parameters used:

$f = 2600 \text{ MHz}$; $\sigma = 2.235 \text{ S/m}$; $\epsilon_r = 51.22$; $\rho = 1000 \text{ kg/m}^3$

Phantom section: Flat Section; Space: 1.0 cm

Test Date: 08-12-2019; Ambient Temp: 22.9°C; Tissue Temp: 22.0°C

Probe: EX3DV4 - SN7417; ConvF(7.37, 7.37, 7.37) @ 2600 MHz; Calibrated: 2/19/2019

Sensor-Surface: 1.4mm (Mechanical Surface Detection)

Electronics: DAE4 Sn665; Calibrated: 2/13/2019

Phantom: LeftTwin-SAM V5.0; Type: QD 000 P40 CD; Serial: TP1375

Measurement SW: DASY52, Version 52.10 (2);SEMCAD X Version 14.6.12 (7470)

2600 MHz System Verification at 20.0 dBm (100 mW)

Area Scan (8x9x1): Measurement grid: dx=12mm, dy=12mm

Zoom Scan (7x7x7)/Cube 0: Measurement grid: dx=5mm, dy=5mm, dz=5mm

Peak SAR (extrapolated) = 11.5 W/kg

SAR(1 g) = 5.31 W/kg

Deviation(1 g) = -3.10%

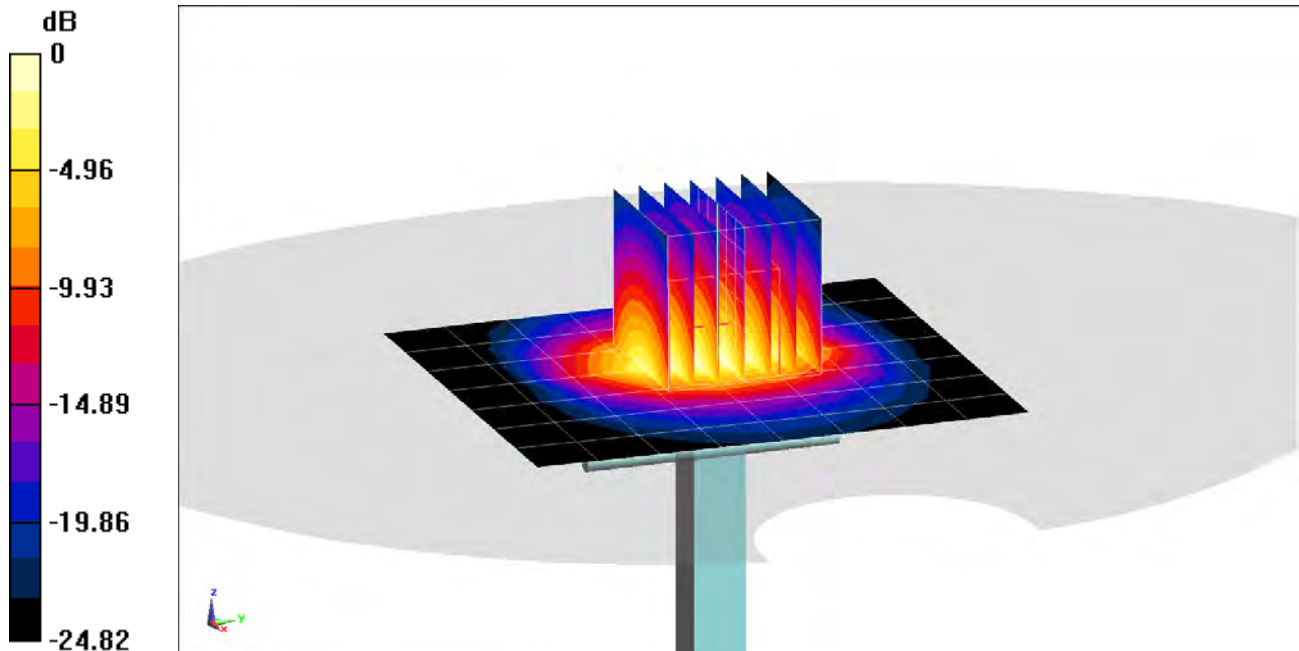

0 dB = 8.96 W/kg = 9.52 dBW/kg

PCTEST ENGINEERING LABORATORY, INC.

DUT: Dipole 2450 MHz; Type: D2450V2; Serial: 797

Communication System: UID 0, CW; Frequency: 2450 MHz; Duty Cycle: 1:1

Medium: 2450 Body; Medium parameters used:

$f = 2450 \text{ MHz}$; $\sigma = 2.04 \text{ S/m}$; $\epsilon_r = 51.56$; $\rho = 1000 \text{ kg/m}^3$

Phantom section: Flat Section; Space: 1.0 cm

Test Date: 08-19-2019; Ambient Temp: 21.6°C; Tissue Temp: 21.0°C

Probe: EX3DV4 - SN7417; ConvF(7.51, 7.51, 7.51) @ 2450 MHz; Calibrated: 2/19/2019

Sensor-Surface: 1.4mm (Mechanical Surface Detection)

Electronics: DAE4 Sn665; Calibrated: 2/13/2019

Phantom: LeftTwin-SAM V5.0; Type: QD 000 P40 CD; Serial: TP1375

Measurement SW: DASY52, Version 52.10 (2);SEMCAD X Version 14.6.12 (7470)

2450 MHz System Verification at 20.0 dBm (100 mW)

Area Scan (8x9x1): Measurement grid: dx=12mm, dy=12mm

Zoom Scan (7x7x7)/Cube 0: Measurement grid: dx=5mm, dy=5mm, dz=5mm

Peak SAR (extrapolated) = 10.5 W/kg

SAR(1 g) = 5.05 W/kg

Deviation(1 g) = -1.17%

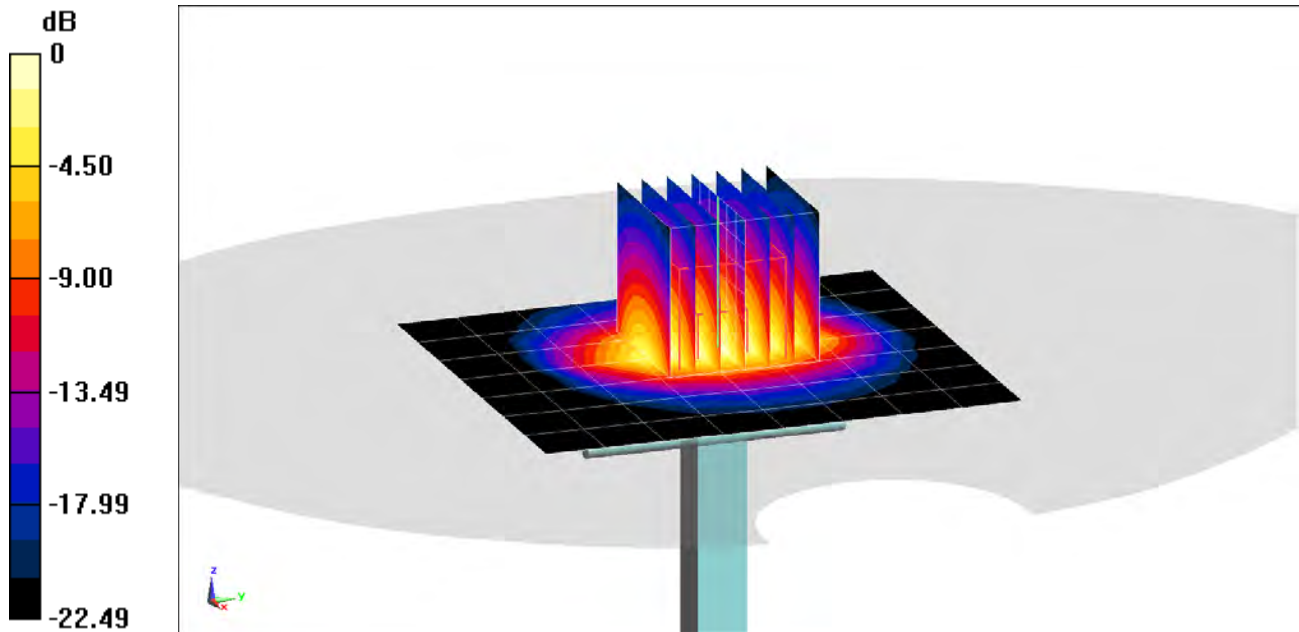

0 dB = 8.49 W/kg = 9.29 dBW/kg

PCTEST ENGINEERING LABORATORY, INC.

DUT: Dipole 2600 MHz; Type: D2600V2; Serial: 1004

Communication System: UID 0, CW; Frequency: 2600 MHz; Duty Cycle: 1:1

Medium: 2450 Body; Medium parameters used:

$f = 2600$ MHz; $\sigma = 2.225$ S/m; $\epsilon_r = 51.087$; $\rho = 1000$ kg/m³

Phantom section: Flat Section; Space: 1.0 cm

Test Date: 08-19-2019; Ambient Temp: 21.6°C; Tissue Temp: 21.0°C

Probe: EX3DV4 - SN7417; ConvF(7.37, 7.37, 7.37) @ 2600 MHz; Calibrated: 2/19/2019

Sensor-Surface: 1.4mm (Mechanical Surface Detection)

Electronics: DAE4 Sn665; Calibrated: 2/13/2019

Phantom: LeftTwin-SAM V5.0; Type: QD 000 P40 CD; Serial: TP1375

Measurement SW: DASY52, Version 52.10 (2);SEMCAD X Version 14.6.12 (7470)

2600 MHz System Verification at 20.0 dBm (100 mW)

Area Scan (8x9x1): Measurement grid: dx=12mm, dy=12mm

Zoom Scan (7x7x7)/Cube 0: Measurement grid: dx=5mm, dy=5mm, dz=5mm

Peak SAR (extrapolated) = 11.9 W/kg

SAR(1 g) = 5.49 W/kg

Deviation(1 g) = 0.18%

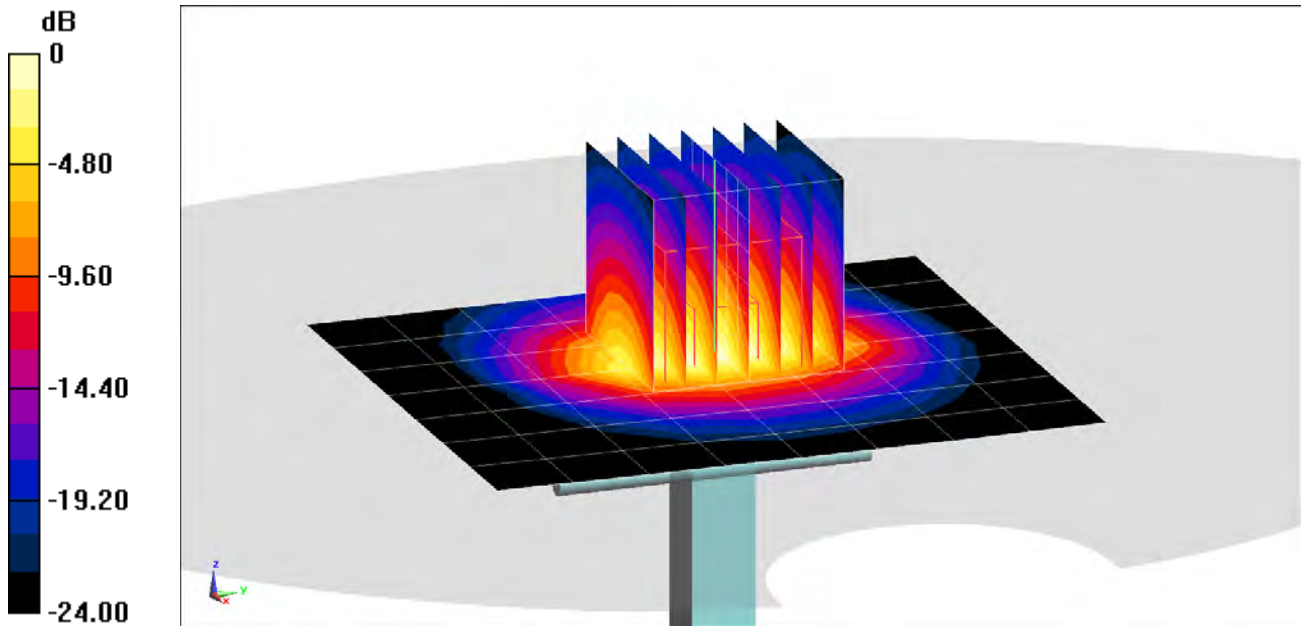

0 dB = 9.53 W/kg = 9.79 dBW/kg

PCTEST ENGINEERING LABORATORY, INC.

DUT: Dipole 5 GHz; Type: D5GHzV2; Serial: 1057

Communication System: UID 0, CW; Frequency: 5250 MHz; Duty Cycle: 1:1

Medium: 5GHz Body Medium parameters used (interpolated):

$f = 5250 \text{ MHz}$; $\sigma = 5.195 \text{ S/m}$; $\epsilon_r = 47.086$; $\rho = 1000 \text{ kg/m}^3$

Phantom section: Flat Section; Space: 1.0 cm

Test Date: 08-05-2019 Ambient Temp: 20.3°C; Tissue Temp: 21.1°C

Probe: EX3DV4 - SN7410; ConvF(4.95, 4.95, 4.95) @ 5250 MHz; Calibrated: 7/16/2019

Sensor-Surface: 1.4mm (Mechanical Surface Detection)

Electronics: DAE4 Sn1322; Calibrated: 7/11/2019

Phantom: Twin-SAM V5.0; Type: QD 000 P40 CD; Serial: 1630

Measurement SW: DASY52, Version 52.10 (2);SEMCAD X Version 14.6.12 (7470)

5250 MHz System Verification at 17.0 dBm (50 mW)

Area Scan (7x7x1): Measurement grid: dx=10mm, dy=10mm

Zoom Scan (8x8x7)/Cube 0: Measurement grid: dx=4mm, dy=4mm, dz=1.4mm; Graded Ratio: 1.4

Peak SAR (extrapolated) = 14.0 W/kg

SAR(1 g) = 3.48 W/kg

Deviation(1 g) = -8.30%

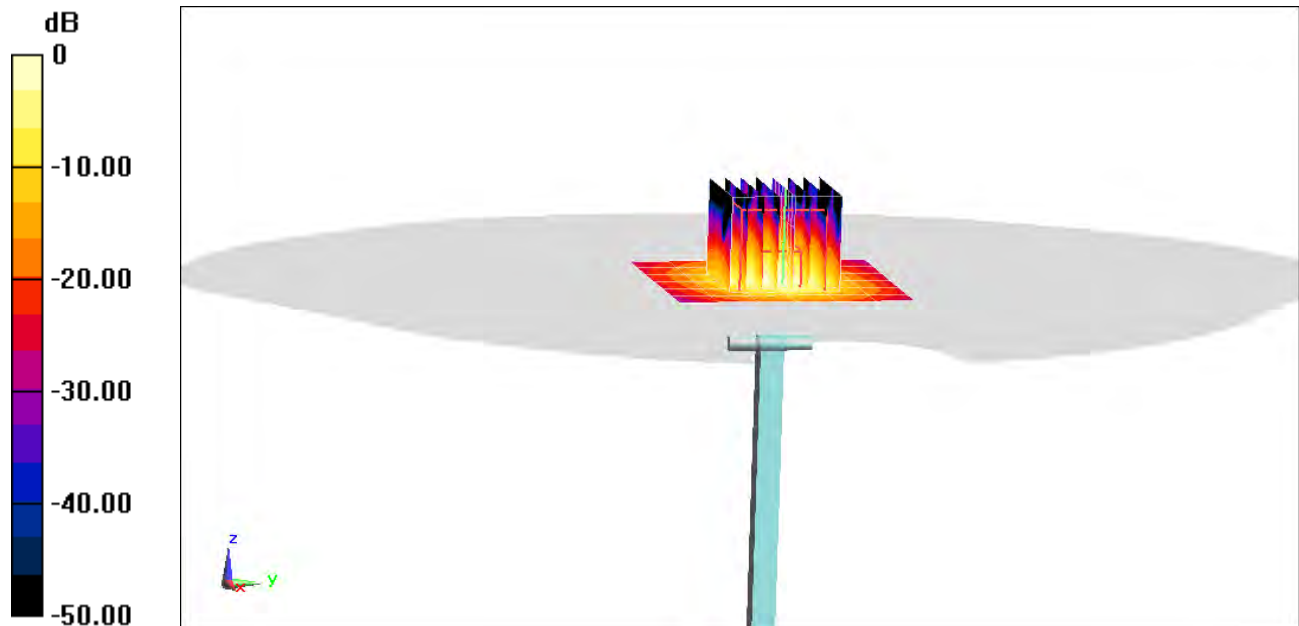

0 dB = 8.20 W/kg = 9.14 dBW/kg

PCTEST ENGINEERING LABORATORY, INC.

DUT: Dipole 5 GHz; Type: D5GHzV2; Serial: 1057

Communication System: UID 0, CW; Frequency: 5600 MHz; Duty Cycle: 1:1

Medium: 5GHz Body Medium parameters used:

$f = 5600 \text{ MHz}$; $\sigma = 5.671 \text{ S/m}$; $\epsilon_r = 46.518$; $\rho = 1000 \text{ kg/m}^3$

Phantom section: Flat Section; Space: 1.0 cm

Test Date: 08-05-2019 Ambient Temp: 20.3°C; Tissue Temp: 21.1°C

Probe: EX3DV4 - SN7410; ConvF(4.42, 4.42, 4.42) @ 5600 MHz; Calibrated: 7/16/2019

Sensor-Surface: 1.4mm (Mechanical Surface Detection)

Electronics: DAE4 Sn1322; Calibrated: 7/11/2019

Phantom: Twin-SAM V5.0; Type: QD 000 P40 CD; Serial: 1630

Measurement SW: DASY52, Version 52.10 (2);SEMCAD X Version 14.6.12 (7470)

5600 MHz System Verification at 17.0 dBm (50 mW)

Area Scan (7x7x1): Measurement grid: dx=10mm, dy=10mm

Zoom Scan (8x8x7)/Cube 0: Measurement grid: dx=4mm, dy=4mm, dz=1.4mm; Graded Ratio: 1.4

Peak SAR (extrapolated) = 16.9 W/kg

SAR(1 g) = 3.81 W/kg

Deviation(1 g) = -4.63%

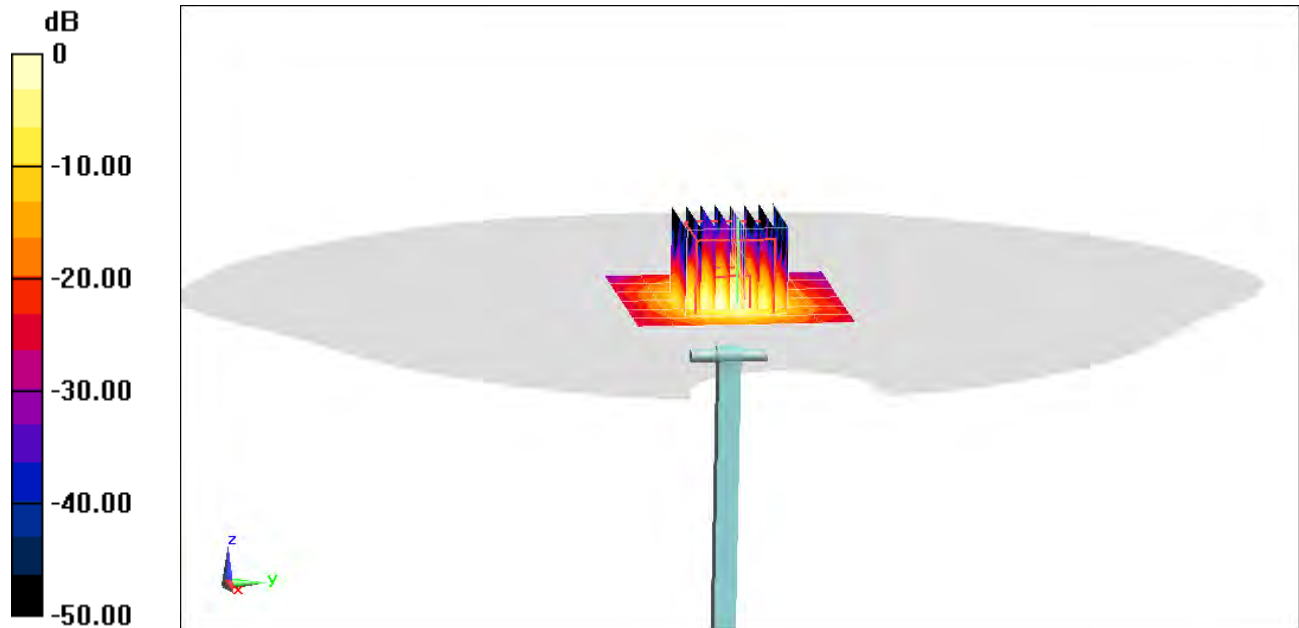

0 dB = 9.18 W/kg = 9.63 dBW/kg

PCTEST ENGINEERING LABORATORY, INC.

DUT: Dipole 5 GHz; Type: D5GHzV2; Serial: 1057

Communication System: UID 0, CW; Frequency: 5750 MHz; Duty Cycle: 1:1
Medium: 5GHz Body Medium parameters used (interpolated):
 $f = 5750 \text{ MHz}$; $\sigma = 5.888 \text{ S/m}$; $\epsilon_r = 46.242$; $\rho = 1000 \text{ kg/m}^3$
Phantom section: Flat Section; Space: 1.0 cm

Test Date: 08-05-2019 Ambient Temp: 20.3°C; Tissue Temp: 21.1°C

Probe: EX3DV4 - SN7410; ConvF(4.6, 4.6, 4.6) @ 5750 MHz; Calibrated: 7/16/2019
Sensor-Surface: 1.4mm (Mechanical Surface Detection)
Electronics: DAE4 Sn1322; Calibrated: 7/11/2019
Phantom: Twin-SAM V5.0; Type: QD 000 P40 CD; Serial: 1630
Measurement SW: DASY52, Version 52.10 (2);SEMCAD X Version 14.6.12 (7470)

5750 MHz System Verification at 17.0 dBm (50 mW)

Area Scan (7x7x1): Measurement grid: dx=10mm, dy=10mm

Zoom Scan (8x8x7)/Cube 0: Measurement grid: dx=4mm, dy=4mm, dz=1.4mm; Graded Ratio: 1.4

Peak SAR (extrapolated) = 16.6 W/kg

SAR(1 g) = 3.56 W/kg

Deviation(1 g) = -7.17%

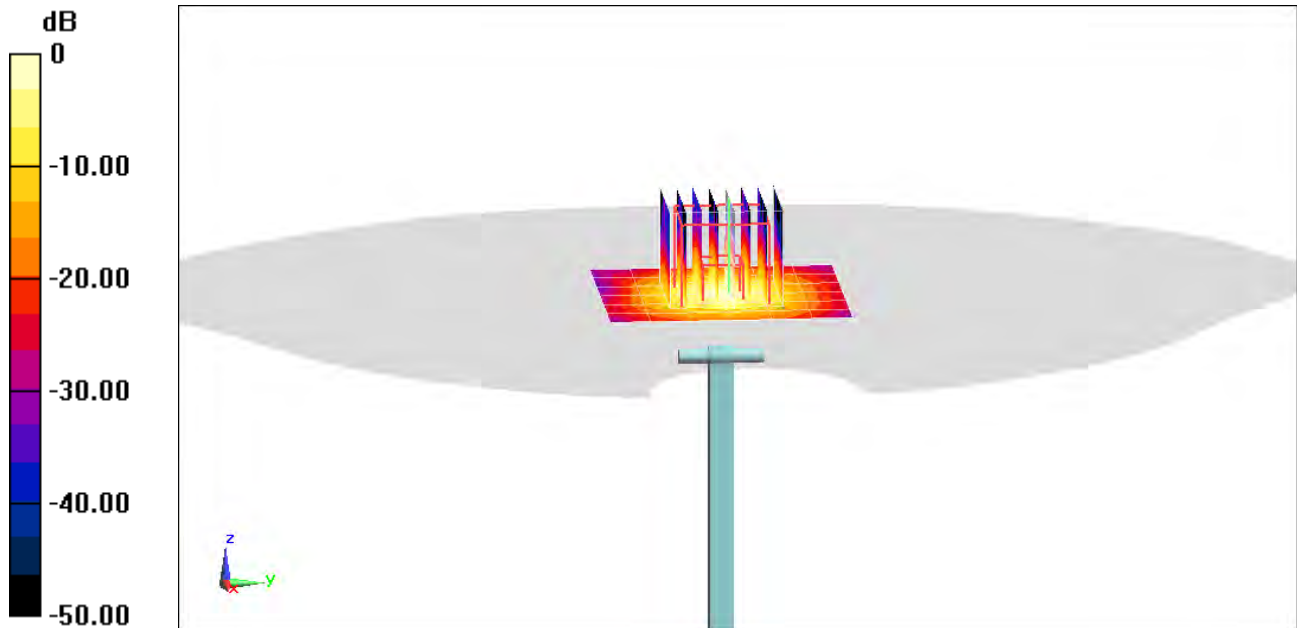

0 dB = 8.78 W/kg = 9.43 dBW/kg

APPENDIX C: PROBE CALIBRATION



Accredited by the Swiss Accreditation Service (SAS)
The Swiss Accreditation Service is one of the signatories to the EA
Multilateral Agreement for the recognition of calibration certificates

Accreditation No.: **SCS 0108**

Client **PC Test**

Certificate No: **D750V3-1003_Jan18**

CALIBRATION CERTIFICATE

Object **D750V3 - SN:1003**

Calibration procedure(s) **QA CAL-05.v9
Calibration procedure for dipole validation kits above 700 MHz**

Calibration date: **January 15, 2018**

BN ✓
01-25-2018

This calibration certificate documents the traceability to national standards, which realize the physical units of measurements (SI).
The measurements and the uncertainties with confidence probability are given on the following pages and are part of the certificate.

BN ✓
02/06/2019

All calibrations have been conducted in the closed laboratory facility; environment temperature (22 ± 3)°C and humidity < 70%.

Calibration Equipment used (M&TE critical for calibration)

Primary Standards	ID #	Cal Date (Certificate No.)	Scheduled Calibration
Power meter NRP	SN: 104778	04-Apr-17 (No. 217-02521/02522)	Apr-18
Power sensor NRP-Z91	SN: 103244	04-Apr-17 (No. 217-02521)	Apr-18
Power sensor NRP-Z91	SN: 103245	04-Apr-17 (No. 217-02522)	Apr-18
Reference 20 dB Attenuator	SN: 5058 (20k)	07-Apr-17 (No. 217-02528)	Apr-18
Type-N mismatch combination	SN: 5047.2 / 06327	07-Apr-17 (No. 217-02529)	Apr-18
Reference Probe EX3DV4	SN: 7349	30-Dec-17 (No. EX3-7349_Dec17)	Dec-18
DAE4	SN: 601	26-Oct-17 (No. DAE4-601_Oct17)	Oct-18

Secondary Standards	ID #	Check Date (in house)	Scheduled Check
Power meter EPM-442A	SN: GB37480704	07-Oct-15 (in house check Oct-16)	In house check: Oct-18
Power sensor HP 8481A	SN: US37292783	07-Oct-15 (in house check Oct-16)	In house check: Oct-18
Power sensor HP 8481A	SN: MY41092317	07-Oct-15 (in house check Oct-16)	In house check: Oct-18
RF generator R&S SMT-06	SN: 100972	15-Jun-15 (in house check Oct-16)	In house check: Oct-18
Network Analyzer HP 8753E	SN: US37390585	18-Oct-01 (in house check Oct-17)	In house check: Oct-18

Calibrated by: **Lefi Klysner** Laboratory Technician
Approved by: **Katja Pokovic** Technical Manager

Signature
Lefi Klysner
Katja Pokovic

Issued: January 15, 2018

This calibration certificate shall not be reproduced except in full without written approval of the laboratory.



Accredited by the Swiss Accreditation Service (SAS)
The Swiss Accreditation Service is one of the signatories to the EA
Multilateral Agreement for the recognition of calibration certificates

Accreditation No.: **SCS 0108**

Glossary:

TSL	tissue simulating liquid
ConvF	sensitivity in TSL / NORM x,y,z
N/A	not applicable or not measured

Calibration is Performed According to the Following Standards:

- IEEE Std 1528-2013, "IEEE Recommended Practice for Determining the Peak Spatial-Averaged Specific Absorption Rate (SAR) in the Human Head from Wireless Communications Devices: Measurement Techniques", June 2013
- IEC 62209-1, "Measurement procedure for the assessment of Specific Absorption Rate (SAR) from hand-held and body-mounted devices used next to the ear (frequency range of 300 MHz to 6 GHz)", July 2016
- IEC 62209-2, "Procedure to determine the Specific Absorption Rate (SAR) for wireless communication devices used in close proximity to the human body (frequency range of 30 MHz to 6 GHz)", March 2010
- KDB 865664, "SAR Measurement Requirements for 100 MHz to 6 GHz"

Additional Documentation:

- DASY4/5 System Handbook

Methods Applied and Interpretation of Parameters:

- Measurement Conditions:** Further details are available from the Validation Report at the end of the certificate. All figures stated in the certificate are valid at the frequency indicated.
- Antenna Parameters with TSL:** The dipole is mounted with the spacer to position its feed point exactly below the center marking of the flat phantom section, with the arms oriented parallel to the body axis.
- Feed Point Impedance and Return Loss:** These parameters are measured with the dipole positioned under the liquid filled phantom. The impedance stated is transformed from the measurement at the SMA connector to the feed point. The Return Loss ensures low reflected power. No uncertainty required.
- Electrical Delay:** One-way delay between the SMA connector and the antenna feed point. No uncertainty required.
- SAR measured:** SAR measured at the stated antenna input power.
- SAR normalized:** SAR as measured, normalized to an input power of 1 W at the antenna connector.
- SAR for nominal TSL parameters:** The measured TSL parameters are used to calculate the nominal SAR result.

The reported uncertainty of measurement is stated as the standard uncertainty of measurement multiplied by the coverage factor $k=2$, which for a normal distribution corresponds to a coverage probability of approximately 95%.

Measurement Conditions

DASY system configuration, as far as not given on page 1.

DASY Version	DASY5	V52.10.0
Extrapolation	Advanced Extrapolation	
Phantom	Modular Flat Phantom	
Distance Dipole Center - TSL	15 mm	with Spacer
Zoom Scan Resolution	dx, dy, dz = 5.0 mm	
Frequency	750 MHz \pm 1 MHz	

Head TSL parameters

The following parameters and calculations were applied.

	Temperature	Permittivity	Conductivity
Nominal Head TSL parameters	22.0 °C	41.9	0.89 mho/m
Measured Head TSL parameters	(22.0 \pm 0.2) °C	40.9 \pm 6 %	0.90 mho/m \pm 6 %
Head TSL temperature change during test	< 0.5 °C	----	----

SAR result with Head TSL

SAR averaged over 1 cm³ (1 g) of Head TSL	Condition	
SAR measured	250 mW input power	2.10 W/kg
SAR for nominal Head TSL parameters	normalized to 1W	8.28 W/kg \pm 17.0 % (k=2)

SAR averaged over 10 cm³ (10 g) of Head TSL	condition	
SAR measured	250 mW input power	1.37 W/kg
SAR for nominal Head TSL parameters	normalized to 1W	5.42 W/kg \pm 16.5 % (k=2)

Body TSL parameters

The following parameters and calculations were applied.

	Temperature	Permittivity	Conductivity
Nominal Body TSL parameters	22.0 °C	55.5	0.96 mho/m
Measured Body TSL parameters	(22.0 \pm 0.2) °C	55.0 \pm 6 %	0.96 mho/m \pm 6 %
Body TSL temperature change during test	< 0.5 °C	----	----

SAR result with Body TSL

SAR averaged over 1 cm³ (1 g) of Body TSL	Condition	
SAR measured	250 mW input power	2.15 W/kg
SAR for nominal Body TSL parameters	normalized to 1W	8.58 W/kg \pm 17.0 % (k=2)

SAR averaged over 10 cm³ (10 g) of Body TSL	condition	
SAR measured	250 mW input power	1.43 W/kg
SAR for nominal Body TSL parameters	normalized to 1W	5.71 W/kg \pm 16.5 % (k=2)

Appendix (Additional assessments outside the scope of SCS 0108)

Antenna Parameters with Head TSL

Impedance, transformed to feed point	53.8 Ω - 2.1 j Ω
Return Loss	- 27.6 dB

Antenna Parameters with Body TSL

Impedance, transformed to feed point	49.2 Ω - 6.2 j Ω
Return Loss	- 24.0 dB

General Antenna Parameters and Design

Electrical Delay (one direction)	1.043 ns
----------------------------------	----------

After long term use with 100W radiated power, only a slight warming of the dipole near the feedpoint can be measured.

The dipole is made of standard semirigid coaxial cable. The center conductor of the feeding line is directly connected to the second arm of the dipole. The antenna is therefore short-circuited for DC-signals. On some of the dipoles, small end caps are added to the dipole arms in order to improve matching when loaded according to the position as explained in the "Measurement Conditions" paragraph. The SAR data are not affected by this change. The overall dipole length is still according to the Standard.

No excessive force must be applied to the dipole arms, because they might bend or the soldered connections near the feedpoint may be damaged.

Additional EUT Data

Manufactured by	SPEAG
Manufactured on	January 21, 2009

Appendix (Additional assessments outside the scope of SCS 0108)

Measurement Conditions

DASY system configuration, as far as not given on page 1 and 3.

Phantom	SAM Head Phantom	For usage with cSAR3DV2-R/L
---------	------------------	-----------------------------

SAR result with SAM Head (Top)

SAR averaged over 1 cm ³ (1 g) of Head TSL	Condition	
SAR measured	250 mW input power	1.98 W/kg
SAR for nominal Head TSL parameters	normalized to 1W	7.94 W/kg ± 17.5 % (k=2)

SAR averaged over 10 cm ³ (10 g) of Head TSL	condition	
SAR measured	250 mW input power	1.33 W/kg
SAR for nominal Head TSL parameters	normalized to 1W	5.32 W/kg ± 16.9 % (k=2)

SAR result with SAM Head (Mouth)

SAR averaged over 1 cm ³ (1 g) of Head TSL	Condition	
SAR measured	250 mW input power	2.05 W/kg
SAR for nominal Head TSL parameters	normalized to 1W	8.22 W/kg ± 17.5 % (k=2)

SAR averaged over 10 cm ³ (10 g) of Head TSL	condition	
SAR measured	250 mW input power	1.38 W/kg
SAR for nominal Head TSL parameters	normalized to 1W	5.52 W/kg ± 16.9 % (k=2)

SAR result with SAM Head (Neck)

SAR averaged over 1 cm ³ (1 g) of Head TSL	Condition	
SAR measured	250 mW input power	2.01 W/kg
SAR for nominal Head TSL parameters	normalized to 1W	8.06 W/kg ± 17.5 % (k=2)

SAR averaged over 10 cm ³ (10 g) of Head TSL	condition	
SAR measured	250 mW input power	1.38 W/kg
SAR for nominal Head TSL parameters	normalized to 1W	5.52 W/kg ± 16.9 % (k=2)

SAR result with SAM Head (Ear)

SAR averaged over 1 cm ³ (1 g) of Head TSL	Condition	
SAR measured	250 mW input power	1.67 W/kg
SAR for nominal Head TSL parameters	normalized to 1W	6.70 W/kg ± 17.5 % (k=2)

SAR averaged over 10 cm ³ (10 g) of Head TSL	condition	
SAR measured	250 mW input power	1.15 W/kg
SAR for nominal Head TSL parameters	normalized to 1W	4.60 W/kg ± 16.9 % (k=2)

DASY5 Validation Report for Head TSL

Date: 12.01.2018

Test Laboratory: SPEAG, Zurich, Switzerland

DUT: Dipole 750 MHz; Type: D750V3; Serial: D750V3 - SN:1003

Communication System: UID 0 - CW; Frequency: 750 MHz

Medium parameters used: $f = 750$ MHz; $\sigma = 0.9$ S/m; $\epsilon_r = 40.9$; $\rho = 1000$ kg/m³

Phantom section: Flat Section

Measurement Standard: DASY5 (IEEE/IEC/ANSI C63.19-2011)

DASY52 Configuration:

- Probe: EX3DV4 - SN7349; ConvF(10.22, 10.22, 10.22); Calibrated: 30.12.2017;
- Sensor-Surface: 1.4mm (Mechanical Surface Detection)
- Electronics: DAE4 Sn601; Calibrated: 26.10.2017
- Phantom: Flat Phantom 4.9 (front); Type: QD 00L P49 AA; Serial: 1001
- DASY52 52.10.0(1446); SEMCAD X 14.6.10(7417)

Dipole Calibration for Head Tissue/Pin=250 mW, d=15mm/Zoom Scan (7x7x7)/Cube 0:

Measurement grid: dx=5mm, dy=5mm, dz=5mm

Reference Value = 59.11 V/m; Power Drift = -0.04 dB

Peak SAR (extrapolated) = 3.15 W/kg

SAR(1 g) = 2.1 W/kg; SAR(10 g) = 1.37 W/kg

Maximum value of SAR (measured) = 2.80 W/kg

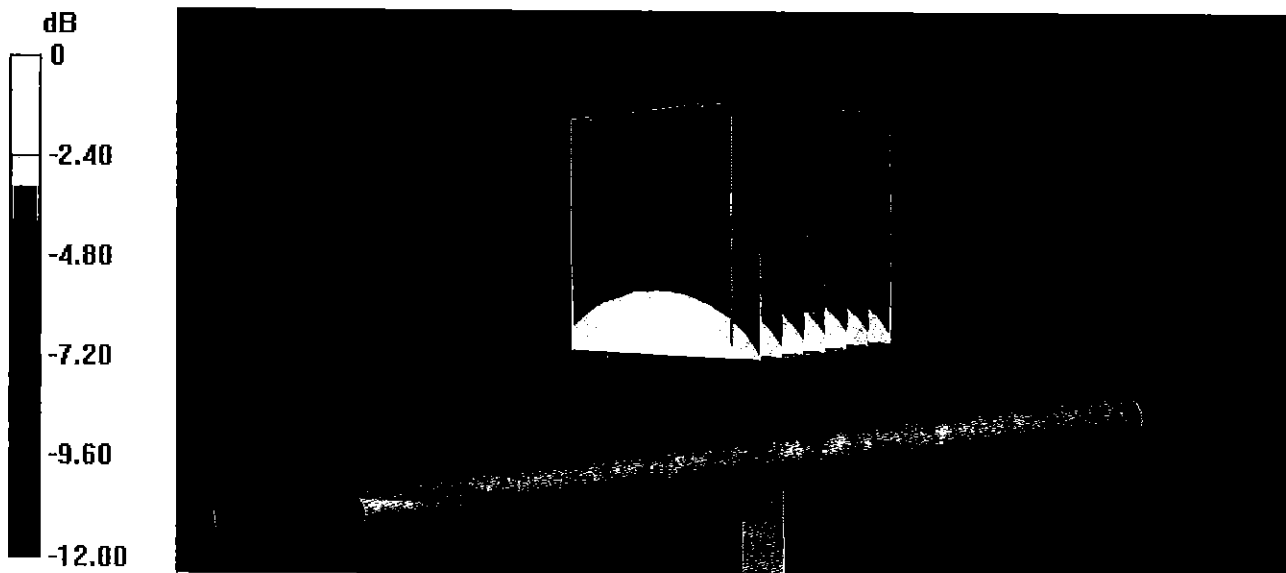

0 dB = 2.80 W/kg = 4.47 dBW/kg

Impedance Measurement Plot for Head TSL

12 Jan 2018 13:14:07
 CH1 S11 1 U FS 1: 53.754 Ω -2.0996 Ω 101.07 pF 750.000 000 MHz

*
 Del
 CA

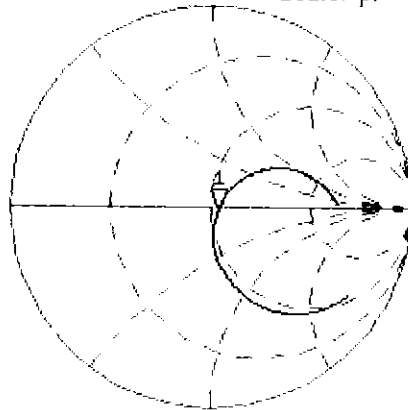

Avg
 16

H1d

CH2 S11 LOG 5 dB/REF -20 dB 1: -27.643 dB 750.000 000 MHz

CA

Avg
 16

H1d

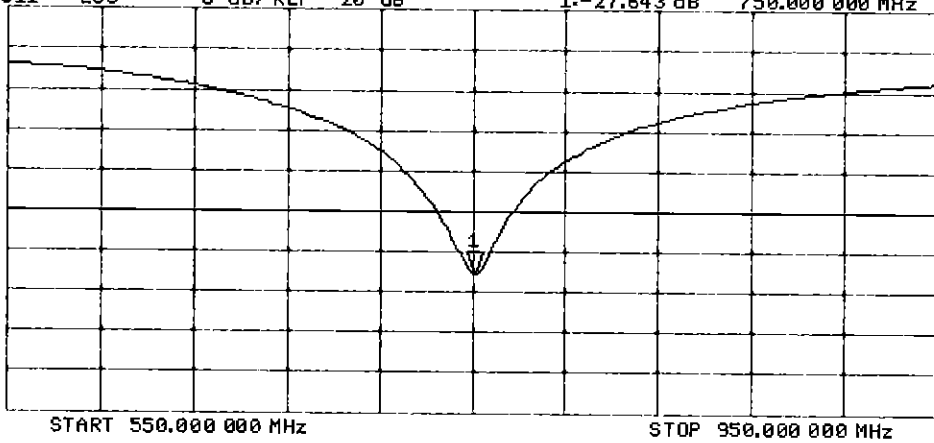

DASY5 Validation Report for Body TSL

Date: 12.01.2018

Test Laboratory: SPEAG, Zurich, Switzerland

DUT: Dipole 750 MHz; Type: D750V3; Serial: D750V3 - SN:1003

Communication System: UID 0 - CW; Frequency: 750 MHz

Medium parameters used: $f = 750$ MHz; $\sigma = 0.96$ S/m; $\epsilon_r = 55$; $\rho = 1000$ kg/m³

Phantom section: Flat Section

Measurement Standard: DASY5 (IEEE/IEC/ANSI C63.19-2011)

DASY52 Configuration:

- Probe: EX3DV4 - SN7349; ConvF(10.19, 10.19, 10.19); Calibrated: 30.12.2017;
- Sensor-Surface: 1.4mm (Mechanical Surface Detection)
- Electronics: DAE4 Sn601; Calibrated: 26.10.2017
- Phantom: Flat Phantom 4.9 (Back); Type: QD 00R P49 AA; Serial: 1005
- DASY52 52.10.0(1446); SEMCAD X 14.6.10(7417)

Dipole Calibration for Body Tissue/Pin=250 mW, d=15mm/Zoom Scan (7x8x7)/Cube 0:

Measurement grid: dx=5mm, dy=5mm, dz=5mm

Reference Value = 57.31 V/m; Power Drift = -0.01 dB

Peak SAR (extrapolated) = 3.17 W/kg

SAR(1 g) = 2.15 W/kg; SAR(10 g) = 1.43 W/kg

Maximum value of SAR (measured) = 2.83 W/kg

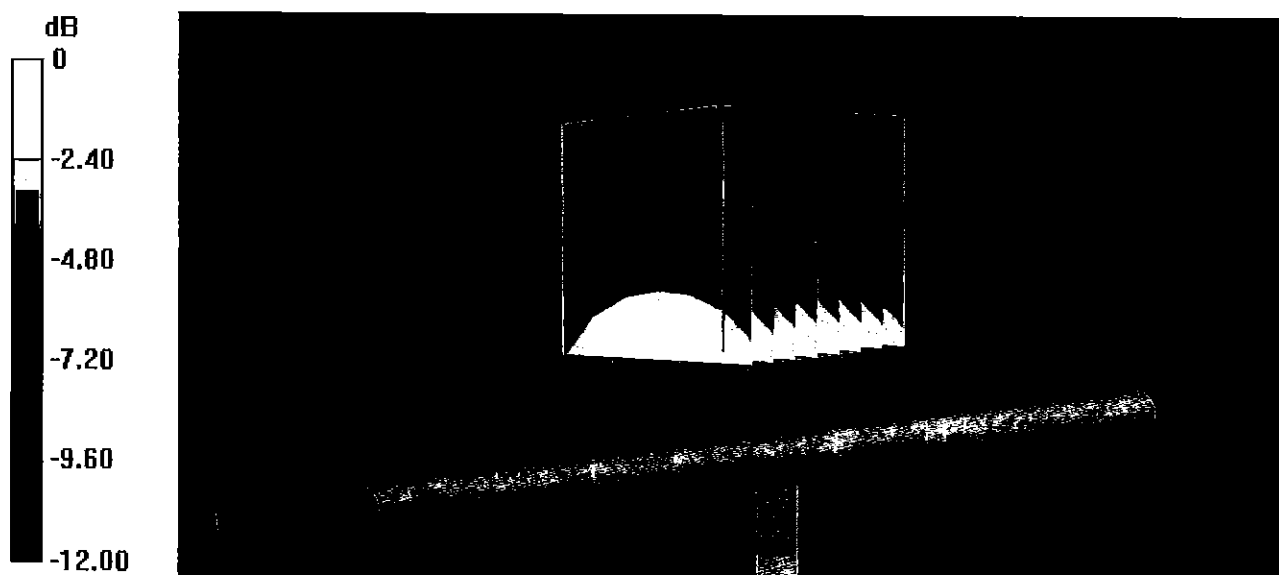

0 dB = 2.83 W/kg = 4.52 dBW/kg

Impedance Measurement Plot for Body TSL

12 Jan 2018 13:13:21
CH1 S11 1 U FS 1: 49.234 Ω -6.1934 Ω 34.264 pF 750.000 000 MHz

*
De1

CA

Avg
16

H1d

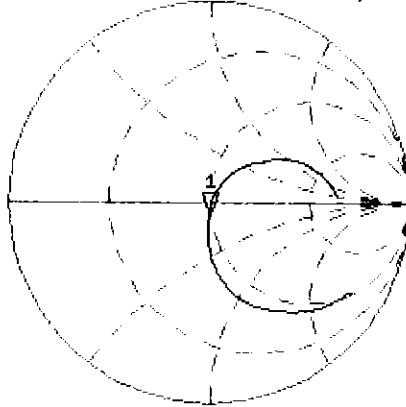

CH2 S11 LOG 5 dB/REF -20 dB 1:-24.047 dB 750.000 000 MHz

CA

Avg
16

H1d

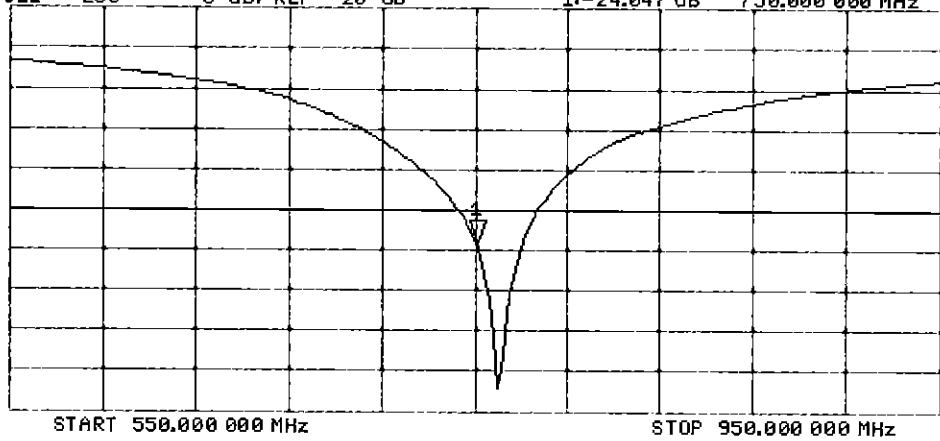

DASY5 Validation Report for SAM Head

Date: 15.01.2018

Test Laboratory: SPEAG, Zurich, Switzerland

DUT: Dipole 750 MHz; Type: D750V3; Serial: D750V3 - SN:1003

Communication System: UID 0 - CW; Frequency: 750 MHz

Medium parameters used: $f = 750$ MHz; $\sigma = 0.9$ S/m; $\epsilon_r = 44.2$; $\rho = 1000$ kg/m³

Measurement Standard: DASY5 (IEEE/IEC/ANSI C63.19-2011)

DASY52 Configuration:

- Probe: EX3DV4 - SN7349; ConvF(10.22, 10.22, 10.22); Calibrated: 30.12.2017;
- Sensor-Surface: 1.4mm (Mechanical Surface Detection)
- Electronics: DAE4 Sn601; Calibrated: 26.10.2017
- Phantom: SAM Head
- DASY52 52.10.0(1446); SEMCAD X 14.6.10(7417)

SAM Head/Top/Zoom Scan (7x7x7)/Cube 0: Measurement grid: dx=5mm, dy=5mm, dz=5mm

Reference Value = 56.79 V/m; Power Drift = -0.01 dB

Peak SAR (extrapolated) = 2.89 W/kg

SAR(1 g) = 1.98 W/kg; SAR(10 g) = 1.33 W/kg

Maximum value of SAR (measured) = 2.58 W/kg

SAM Head/Mouth/Zoom Scan (7x7x7)/Cube 0: Measurement grid: dx=5mm, dy=5mm, dz=5mm

Reference Value = 56.85 V/m; Power Drift = -0.06 dB

Peak SAR (extrapolated) = 2.94 W/kg

SAR(1 g) = 2.05 W/kg; SAR(10 g) = 1.38 W/kg

Maximum value of SAR (measured) = 2.62 W/kg

SAM Head/Neck/Zoom Scan (7x7x7)/Cube 0: Measurement grid: dx=5mm, dy=5mm, dz=5mm

Reference Value = 56.29 V/m; Power Drift = 0.04 dB

Peak SAR (extrapolated) = 2.78 W/kg

SAR(1 g) = 2.01 W/kg; SAR(10 g) = 1.38 W/kg

Maximum value of SAR (measured) = 2.56 W/kg

SAM Head/Ear/Zoom Scan (7x7x7)/Cube 0: Measurement grid: dx=5mm, dy=5mm, dz=5mm

Reference Value = 51.01 V/m; Power Drift = 0.02 dB

Peak SAR (extrapolated) = 2.31 W/kg

SAR(1 g) = 1.67 W/kg; SAR(10 g) = 1.15 W/kg

Maximum value of SAR (measured) = 2.11 W/kg

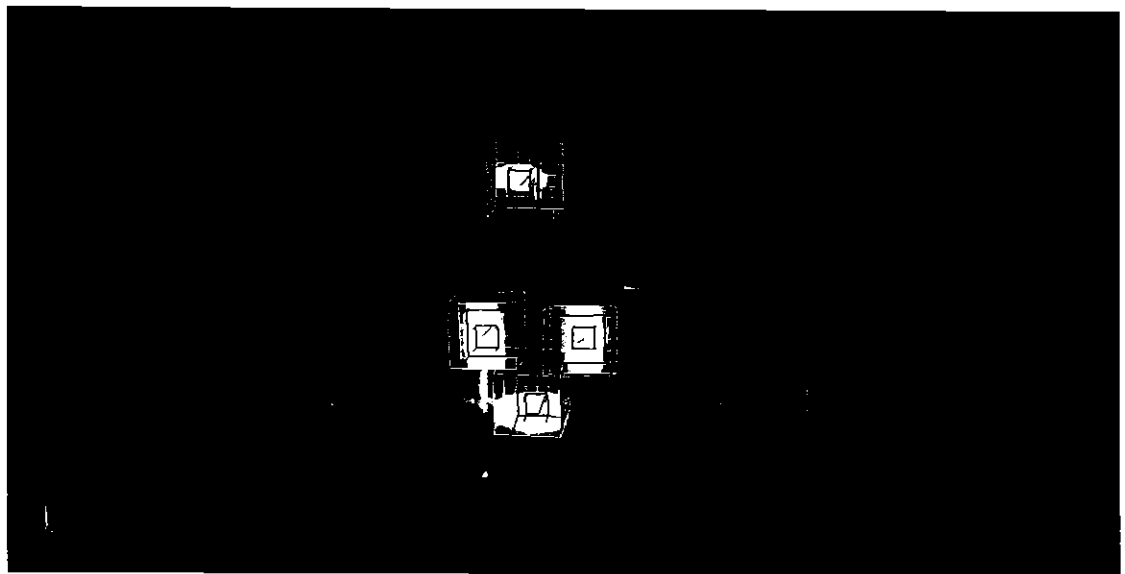
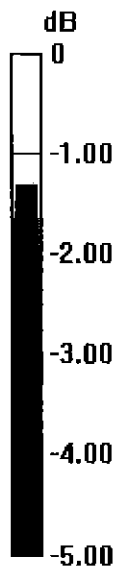

0 dB = 2.58 W/kg = 4.12 dBW/kg

Certification of Calibration

Object: D750V3 – SN: 1003

Calibration procedure(s): Procedure for Calibration Extension for SAR Dipoles.

Extension Calibration date: 1/15/2019

Description: SAR Validation Dipole at 750 MHz.

Calibration Equipment used:

Manufacturer	Model	Description	Cal Date	Cal Interval	Cal Due	Serial Number
Agilent	8753ES	S-Parameter Network Analyzer	2/8/2018	Annual	2/8/2019	US39170122
Agilent	N5182A	MXG Vector Signal Generator	4/18/2018	Annual	4/18/2019	MY47420800
Amplifier Research	15S1G6	Amplifier	CBT	N/A	CBT	433971
Anritsu	MA2411B	Pulse Power Sensor	3/2/2018	Annual	3/2/2019	1207364
Anritsu	MA2411B	Pulse Power Sensor	3/2/2018	Annual	3/2/2019	1339018
Anritsu	ML2495A	Power Meter	10/21/2018	Annual	10/21/2019	941001
Control Company	4040	Therm./Clock/Humidity Monitor	3/31/2017	Biennial	3/31/2019	170232394
Control Company	4352	Ultra Long Stem Thermometer	5/2/2017	Biennial	5/2/2019	170330156
Keysight	772D	Dual Directional Coupler	CBT	N/A	CBT	MY52180215
Keysight Technologies	85033E	Standard Mechanical Calibration Kit (DC to 9GHz, 3.5mm)	6/4/2018	Annual	6/4/2019	MY53401181
MiniCircuits	VLF-6000+	Low Pass Filter	CBT	N/A	CBT	N/A
Mini-Circuits	BW-N20W5+	DC to 18 GHz Precision Fixed 20 dB Attenuator	CBT	N/A	CBT	N/A
Narda	4772-3	Attenuator (3dB)	CBT	N/A	CBT	9406
Pasternack	PE2208-6	Bidirectional Coupler	CBT	N/A	CBT	N/A
Seekonk	NC-100	Torque Wrench	7/11/2018	Annual	7/11/2019	N/A
SPEAG	DAE4	Dasy Data Acquisition Electronics	10/3/2018	Annual	10/3/2019	1558
SPEAG	DAE4	Dasy Data Acquisition Electronics	6/18/2018	Annual	6/18/2019	1334
SPEAG	DAK-3.5	Dielectric Assessment Kit	9/11/2018	Annual	9/11/2019	1091
SPEAG	EX3DV4	SAR Probe	8/23/2018	Annual	8/23/2019	7308
SPEAG	EX3DV4	SAR Probe	6/25/2018	Annual	6/25/2019	7409

Measurement Uncertainty = $\pm 23\%$ (k=2)

	Name	Function	Signature
Calibrated By:	Brodie Halfoster	Test Engineer	<i>BRODIE HALFOSTER</i>
Approved By:	Kaitlin O'Keefe	Senior Technical Manager	<i>KOK</i>

DIPOLE CALIBRATION EXTENSION

Per KDB 865664 D01, calibration intervals of up to three years may be considered for reference dipoles when it is demonstrated that the SAR target, impedance and return loss of a dipole have remained stable according to the following requirements:

1. The measured SAR does not deviate more than 10% from the target on the calibration certificate.
2. The return-loss does not deviate more than 20% from the previous measurement and meets the required 20dB minimum return-loss requirement.
3. The measurement of real or imaginary parts of impedance does not deviate more than 5Ω from the previous measurement.

The following dipole was checked to pass the above 3 requirements to have 2-year calibration period from the calibration date:

Calibration Date	Extension Date	Certificate Electrical Delay (ns)	Certificate SAR Target Head (1g) W/kg @ 23.0 dBm	Measured Head SAR (1g) W/kg @ 23.0 dBm	Deviation 1g (%)	Certificate SAR Target Head (10g) W/kg @ 23.0 dBm	Measured Head SAR (10g) W/kg @ 23.0 dBm	Deviation 10g (%)	Certificate Impedance Head (Ohm) Real	Measured Impedance Head (Ohm) Real	Difference (Ohm) Real	Certificate Impedance Head (Ohm) Imaginary	Measured Impedance Head (Ohm) Imaginary	Difference (Ohm) Imaginary	Certificate Return Loss Head (dB)	Measured Return Loss Head (dB)	Deviation (%)	PASS/FAIL
1/15/2018	1/15/2019	1.043	1.656	1.75	5.88%	1.08	1.15	6.09%	53.8	54.8	1	-2.1	-2.2	0.1	-27.6	-25.8	6.50%	PASS
Calibration Date	Extension Date	Certificate Electrical Delay (ns)	Certificate SAR Target Body (1g) W/kg @ 23.0 dBm	Measured Body SAR (1g) W/kg @ 23.0 dBm	Deviation 1g (%)	Certificate SAR Target Body (10g) W/kg @ 23.0 dBm	Measured Body SAR (10g) W/kg @ 23.0 dBm	Deviation 10g (%)	Certificate Impedance Body (Ohm) Real	Measured Impedance Body (Ohm) Real	Difference (Ohm) Real	Certificate Impedance Body (Ohm) Imaginary	Measured Impedance Body (Ohm) Imaginary	Difference (Ohm) Imaginary	Certificate Return Loss Body (dB)	Measured Return Loss Body (dB)	Deviation (%)	PASS/FAIL
1/15/2018	1/15/2019	1.043	1.716	1.84	7.23%	1.14	1.23	7.71%	49.2	49	0.2	-6.2	-5.1	1.1	-24	-25.6	-6.80%	PASS

Impedance & Return-Loss Measurement Plot for Head TSL

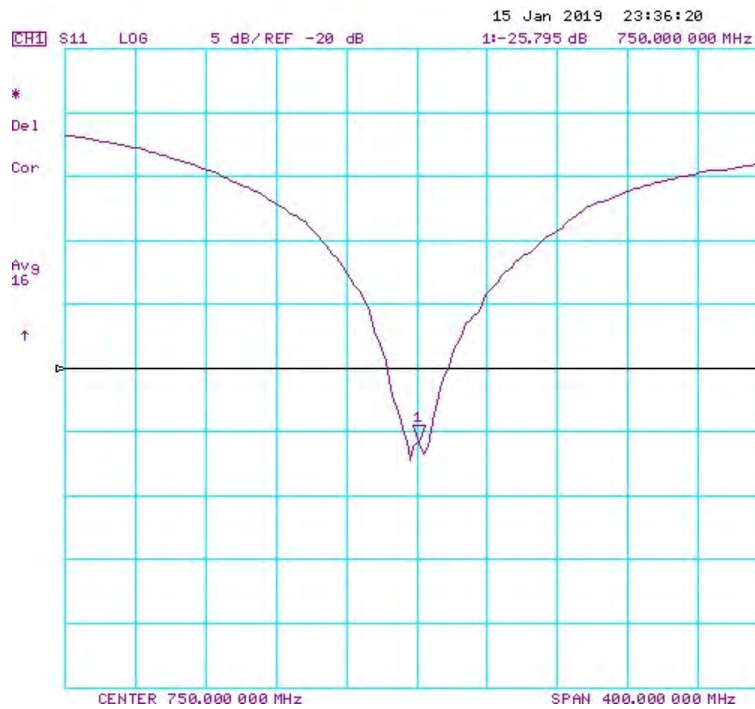
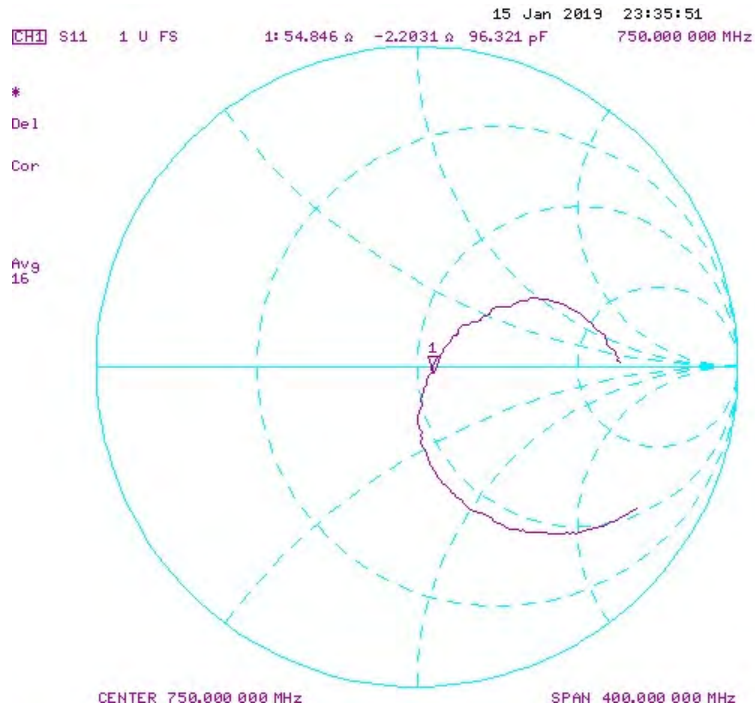

Impedance & Return-Loss Measurement Plot for Body TSL

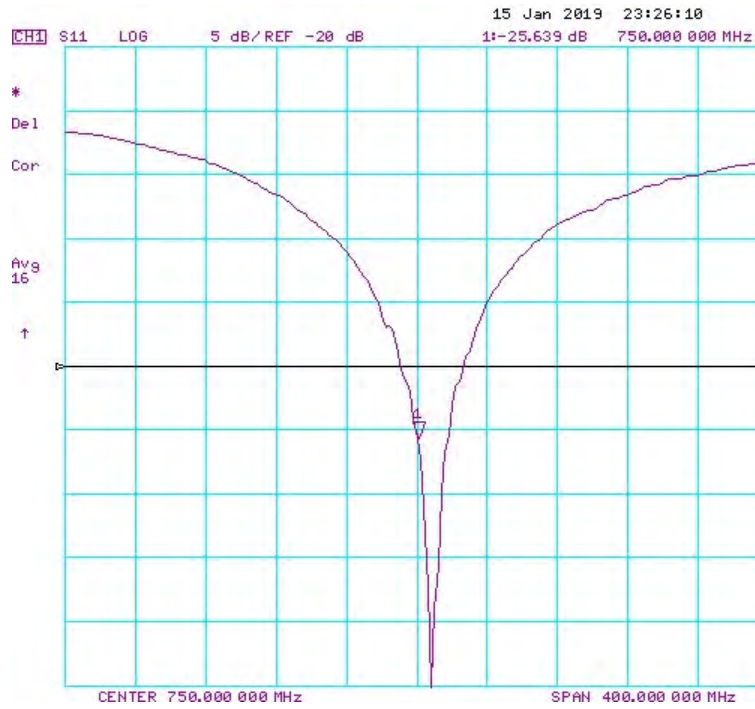
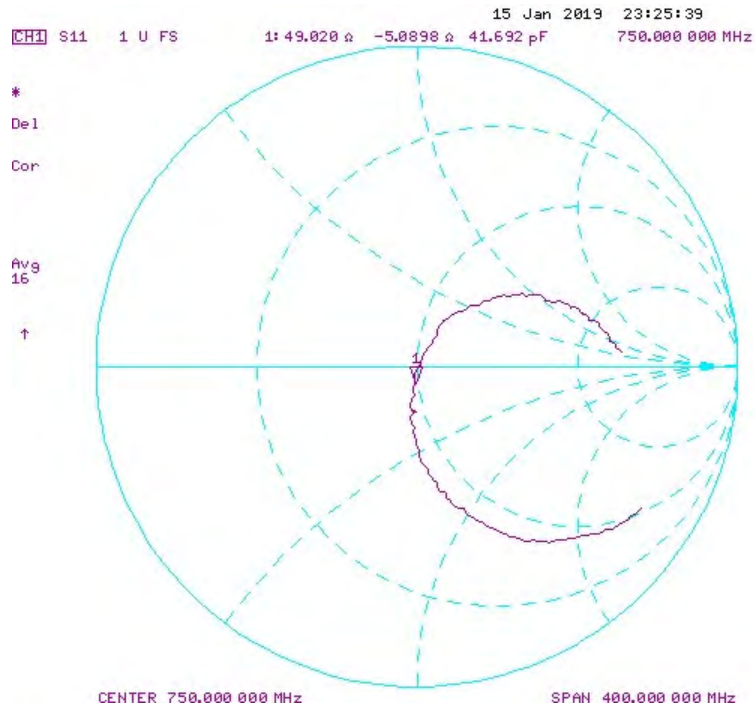



Accredited by the Swiss Accreditation Service (SAS)
The Swiss Accreditation Service is one of the signatories to the EA
Multilateral Agreement for the recognition of calibration certificates

Accreditation No.: **SCS 0108**

Client **PC Test**

Certificate No: **D835V2-4d047_Mar19**

CALIBRATION CERTIFICATE

Object **D835V2 - SN:4d047**

Calibration procedure(s) **QA CAL-05.v11
Calibration Procedure for SAR Validation Sources between 0.7-3 GHz**

Calibration date: **March 13, 2019**

BN ✓
04-12-2019

This calibration certificate documents the traceability to national standards, which realize the physical units of measurements (SI).
The measurements and the uncertainties with confidence probability are given on the following pages and are part of the certificate.

All calibrations have been conducted in the closed laboratory facility: environment temperature (22 ± 3)°C and humidity < 70%.

Calibration Equipment used (M&TE critical for calibration)

Primary Standards	ID #	Cal Date (Certificate No.)	Scheduled Calibration
Power meter NRP	SN: 104778	04-Apr-18 (No. 217-02672/02673)	Apr-19
Power sensor NRP-Z91	SN: 103244	04-Apr-18 (No. 217-02672)	Apr-19
Power sensor NRP-Z91	SN: 103245	04-Apr-18 (No. 217-02673)	Apr-19
Reference 20 dB Attenuator	SN: 5058 (20k)	04-Apr-18 (No. 217-02682)	Apr-19
Type-N mismatch combination	SN: 5047.2 / 06327	04-Apr-18 (No. 217-02683)	Apr-19
Reference Probe EX3DV4	SN: 7349	31-Dec-18 (No. EX3-7349_Dec18)	Dec-19
DAE4	SN: 601	04-Oct-18 (No. DAE4-601_Oct18)	Oct-19

Secondary Standards	ID #	Check Date (in house)	Scheduled Check
Power meter E4419B	SN: GB39512475	07-Oct-15 (in house check Feb-19)	In house check: Oct-20
Power sensor HP 8481A	SN: US37292783	07-Oct-15 (in house check Oct-18)	In house check: Oct-20
Power sensor HP 8481A	SN: MY41092317	07-Oct-15 (in house check Oct-18)	In house check: Oct-20
RF generator R&S SMT-06	SN: 100972	15-Jun-15 (in house check Oct-18)	In house check: Oct-20
Network Analyzer Agilent E8358A	SN: US41080477	31-Mar-14 (in house check Oct-18)	In house check: Oct-19

Calibrated by:	Name Manu Seitz	Function Laboratory Technician	Signature
Approved by:	Name Katja Pokovic	Technical Manager	

Issued: March 13, 2019

This calibration certificate shall not be reproduced except in full without written approval of the laboratory.



Accredited by the Swiss Accreditation Service (SAS)

Accreditation No.: **SCS 0108**

The Swiss Accreditation Service is one of the signatories to the EA
Multilateral Agreement for the recognition of calibration certificates

Glossary:

TSL	tissue simulating liquid
ConvF	sensitivity in TSL / NORM x,y,z
N/A	not applicable or not measured

Calibration is Performed According to the Following Standards:

- IEEE Std 1528-2013, "IEEE Recommended Practice for Determining the Peak Spatial-Averaged Specific Absorption Rate (SAR) in the Human Head from Wireless Communications Devices: Measurement Techniques", June 2013
- IEC 62209-1, "Measurement procedure for the assessment of Specific Absorption Rate (SAR) from hand-held and body-mounted devices used next to the ear (frequency range of 300 MHz to 6 GHz)", July 2016
- IEC 62209-2, "Procedure to determine the Specific Absorption Rate (SAR) for wireless communication devices used in close proximity to the human body (frequency range of 30 MHz to 6 GHz)", March 2010
- KDB 865664, "SAR Measurement Requirements for 100 MHz to 6 GHz"

Additional Documentation:

- DASY4/5 System Handbook

Methods Applied and Interpretation of Parameters:

- Measurement Conditions:** Further details are available from the Validation Report at the end of the certificate. All figures stated in the certificate are valid at the frequency indicated.
- Antenna Parameters with TSL:** The dipole is mounted with the spacer to position its feed point exactly below the center marking of the flat phantom section, with the arms oriented parallel to the body axis.
- Feed Point Impedance and Return Loss:** These parameters are measured with the dipole positioned under the liquid filled phantom. The impedance stated is transformed from the measurement at the SMA connector to the feed point. The Return Loss ensures low reflected power. No uncertainty required.
- Electrical Delay:** One-way delay between the SMA connector and the antenna feed point. No uncertainty required.
- SAR measured:** SAR measured at the stated antenna input power.
- SAR normalized:** SAR as measured, normalized to an input power of 1 W at the antenna connector.
- SAR for nominal TSL parameters:** The measured TSL parameters are used to calculate the nominal SAR result.

The reported uncertainty of measurement is stated as the standard uncertainty of measurement multiplied by the coverage factor $k=2$, which for a normal distribution corresponds to a coverage probability of approximately 95%.

Measurement Conditions

DASY system configuration, as far as not given on page 1.

DASY Version	DASY5	V52.10.2
Extrapolation	Advanced Extrapolation	
Phantom	Modular Flat Phantom	
Distance Dipole Center - TSL	15 mm	with Spacer
Zoom Scan Resolution	dx, dy, dz = 5 mm	
Frequency	835 MHz \pm 1 MHz	

Head TSL parameters

The following parameters and calculations were applied.

	Temperature	Permittivity	Conductivity
Nominal Head TSL parameters	22.0 °C	41.5	0.90 mho/m
Measured Head TSL parameters	(22.0 \pm 0.2) °C	41.9 \pm 6 %	0.91 mho/m \pm 6 %
Head TSL temperature change during test	< 0.5 °C	----	----

SAR result with Head TSL

SAR averaged over 1 cm³ (1 g) of Head TSL	Condition	
SAR measured	250 mW input power	2.37 W/kg
SAR for nominal Head TSL parameters	normalized to 1W	9.42 W/kg \pm 17.0 % (k=2)

SAR averaged over 10 cm³ (10 g) of Head TSL	condition	
SAR measured	250 mW input power	1.54 W/kg
SAR for nominal Head TSL parameters	normalized to 1W	6.13 W/kg \pm 16.5 % (k=2)

Body TSL parameters

The following parameters and calculations were applied.

	Temperature	Permittivity	Conductivity
Nominal Body TSL parameters	22.0 °C	55.2	0.97 mho/m
Measured Body TSL parameters	(22.0 \pm 0.2) °C	54.3 \pm 6 %	1.01 mho/m \pm 6 %
Body TSL temperature change during test	< 0.5 °C	----	----

SAR result with Body TSL

SAR averaged over 1 cm³ (1 g) of Body TSL	Condition	
SAR measured	250 mW input power	2.45 W/kg
SAR for nominal Body TSL parameters	normalized to 1W	9.47 W/kg \pm 17.0 % (k=2)

SAR averaged over 10 cm³ (10 g) of Body TSL	condition	
SAR measured	250 mW input power	1.61 W/kg
SAR for nominal Body TSL parameters	normalized to 1W	6.27 W/kg \pm 16.5 % (k=2)

Appendix (Additional assessments outside the scope of SCS 0108)

Antenna Parameters with Head TSL

Impedance, transformed to feed point	51.4 Ω - 2.6 j Ω
Return Loss	- 30.7 dB

Antenna Parameters with Body TSL

Impedance, transformed to feed point	46.8 Ω - 6.1 j Ω
Return Loss	- 22.9 dB

General Antenna Parameters and Design

Electrical Delay (one direction)	1.387 ns
----------------------------------	----------

After long term use with 100W radiated power, only a slight warming of the dipole near the feedpoint can be measured.

The dipole is made of standard semirigid coaxial cable. The center conductor of the feeding line is directly connected to the second arm of the dipole. The antenna is therefore short-circuited for DC-signals. On some of the dipoles, small end caps are added to the dipole arms in order to improve matching when loaded according to the position as explained in the "Measurement Conditions" paragraph. The SAR data are not affected by this change. The overall dipole length is still according to the Standard.

No excessive force must be applied to the dipole arms, because they might bend or the soldered connections near the feedpoint may be damaged.

Additional EUT Data

Manufactured by	SPEAG
-----------------	-------

DASY5 Validation Report for Head TSL

Date: 13.03.2019

Test Laboratory: SPEAG, Zurich, Switzerland

DUT: Dipole 835 MHz; Type: D835V2; Serial: D835V2 - SN:4d047

Communication System: UID 0 - CW; Frequency: 835 MHz

Medium parameters used: $f = 835$ MHz; $\sigma = 0.91$ S/m; $\epsilon_r = 41.9$; $\rho = 1000$ kg/m³

Phantom section: Flat Section

Measurement Standard: DASY5 (IEEE/IEC/ANSI C63.19-2011)

DASY52 Configuration:

- Probe: EX3DV4 - SN7349; ConvF(10, 10, 10) @ 835 MHz; Calibrated: 31.12.2018
- Sensor-Surface: 1.4mm (Mechanical Surface Detection)
- Electronics: DAE4 Sn601; Calibrated: 04.10.2018
- Phantom: Flat Phantom 4.9 (front); Type: QD 00L P49 AA; Serial: 1001
- DASY52 52.10.2(1495); SEMCAD X 14.6.12(7450)

Dipole Calibration for Head Tissue/Pin=250 mW, d=15mm/Zoom Scan (7x7x7)/Cube 0:

Measurement grid: dx=5mm, dy=5mm, dz=5mm

Reference Value = 62.48 V/m; Power Drift = -0.08 dB

Peak SAR (extrapolated) = 3.60 W/kg

SAR(1 g) = 2.37 W/kg; SAR(10 g) = 1.54 W/kg

Maximum value of SAR (measured) = 3.18 W/kg

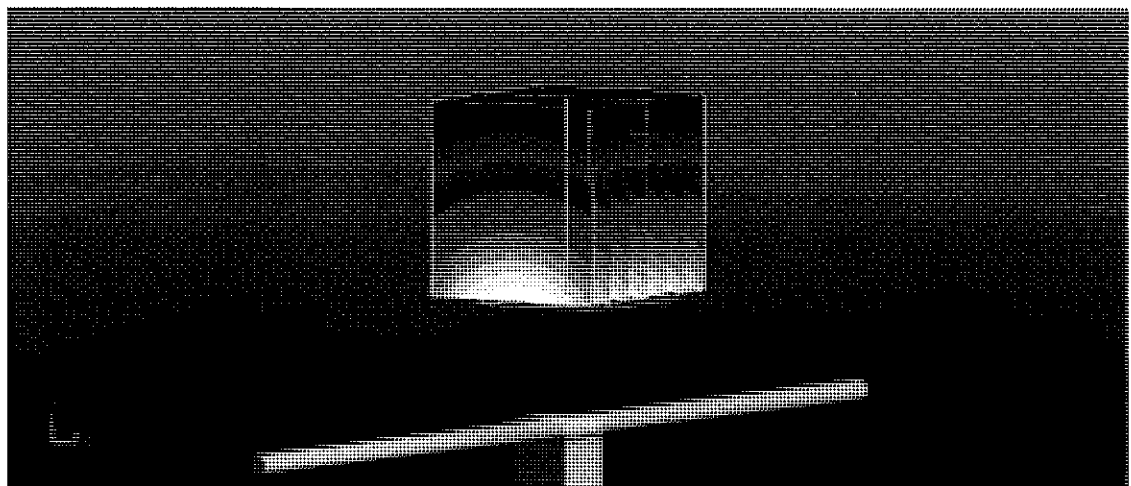
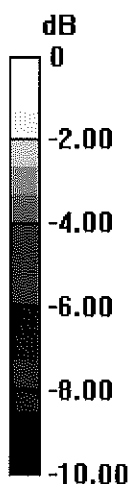

0 dB = 3.18 W/kg = 5.02 dBW/kg

Impedance Measurement Plot for Head TSL

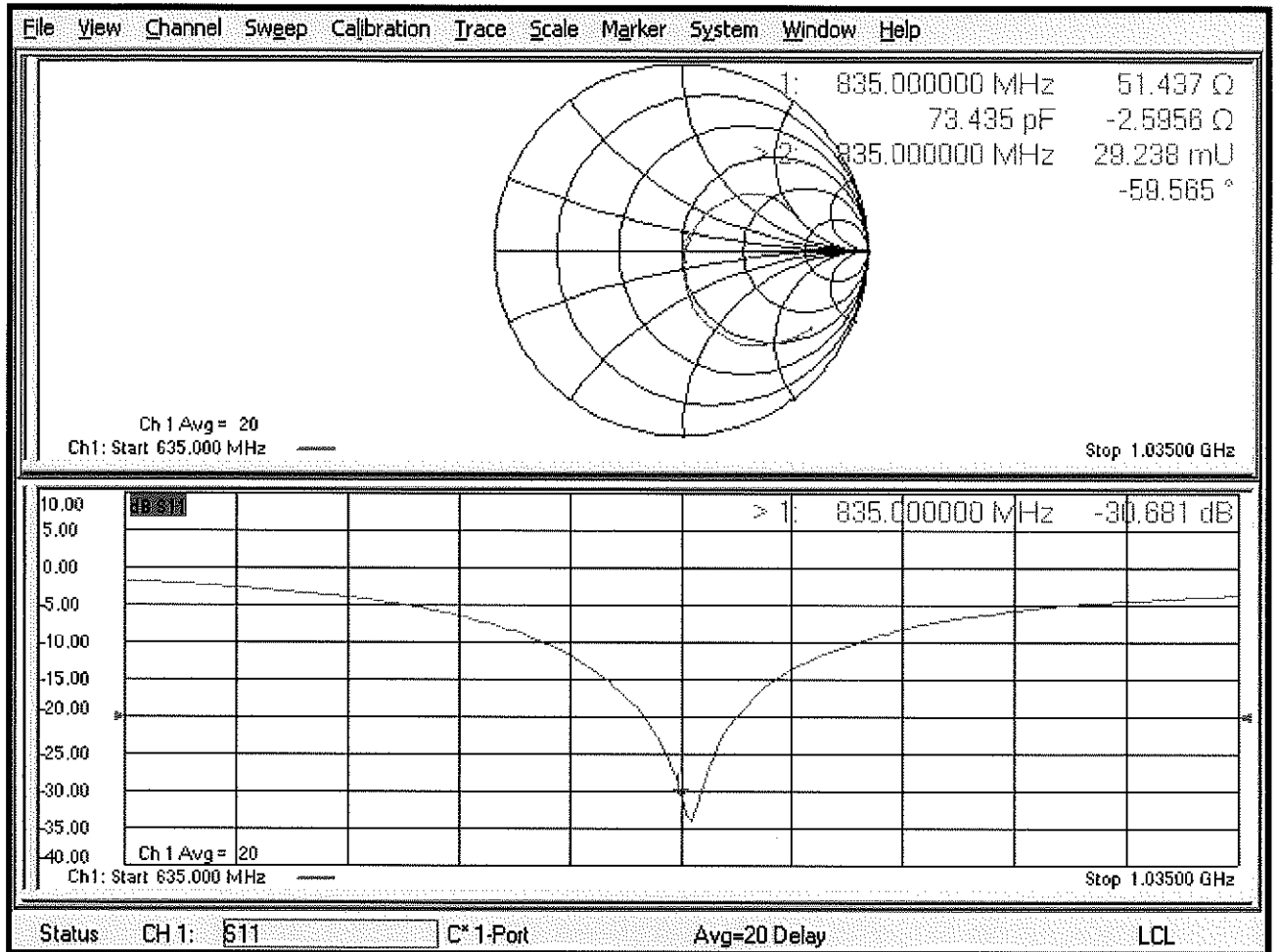

DASY5 Validation Report for Body TSL

Date: 13.03.2019

Test Laboratory: SPEAG, Zurich, Switzerland

DUT: Dipole 835 MHz; Type: D835V2; Serial: D835V2 - SN:4d047

Communication System: UID 0 - CW; Frequency: 835 MHz

Medium parameters used: $f = 835 \text{ MHz}$; $\sigma = 1.01 \text{ S/m}$; $\epsilon_r = 54.3$; $\rho = 1000 \text{ kg/m}^3$

Phantom section: Flat Section

Measurement Standard: DASY5 (IEEE/IEC/ANSI C63.19-2011)

DASY52 Configuration:

- Probe: EX3DV4 - SN7349; ConvF(10.15, 10.15, 10.15) @ 835 MHz; Calibrated: 31.12.2018
- Sensor-Surface: 1.4mm (Mechanical Surface Detection)
- Electronics: DAE4 Sn601; Calibrated: 04.10.2018
- Phantom: Flat Phantom 4.9 (Back); Type: QD 00R P49 AA; Serial: 1005
- DASY52 52.10.2(1495); SEMCAD X 14.6.12(7450)

Dipole Calibration for Body Tissue/Pin=250 mW, d=15mm/Zoom Scan (7x7x7)/Cube 0:

Measurement grid: $dx=5\text{mm}$, $dy=5\text{mm}$, $dz=5\text{mm}$

Reference Value = 60.49 V/m; Power Drift = -0.02 dB

Peak SAR (extrapolated) = 3.58 W/kg

SAR(1 g) = 2.45 W/kg; SAR(10 g) = 1.61 W/kg

Maximum value of SAR (measured) = 3.23 W/kg

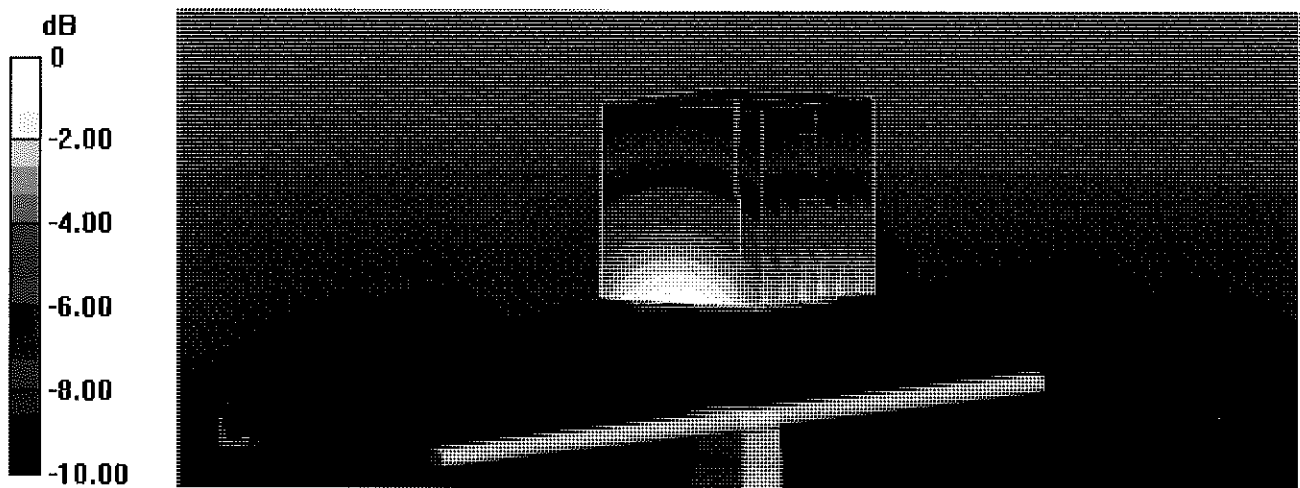

0 dB = 3.23 W/kg = 5.09 dBW/kg

Impedance Measurement Plot for Body TSL

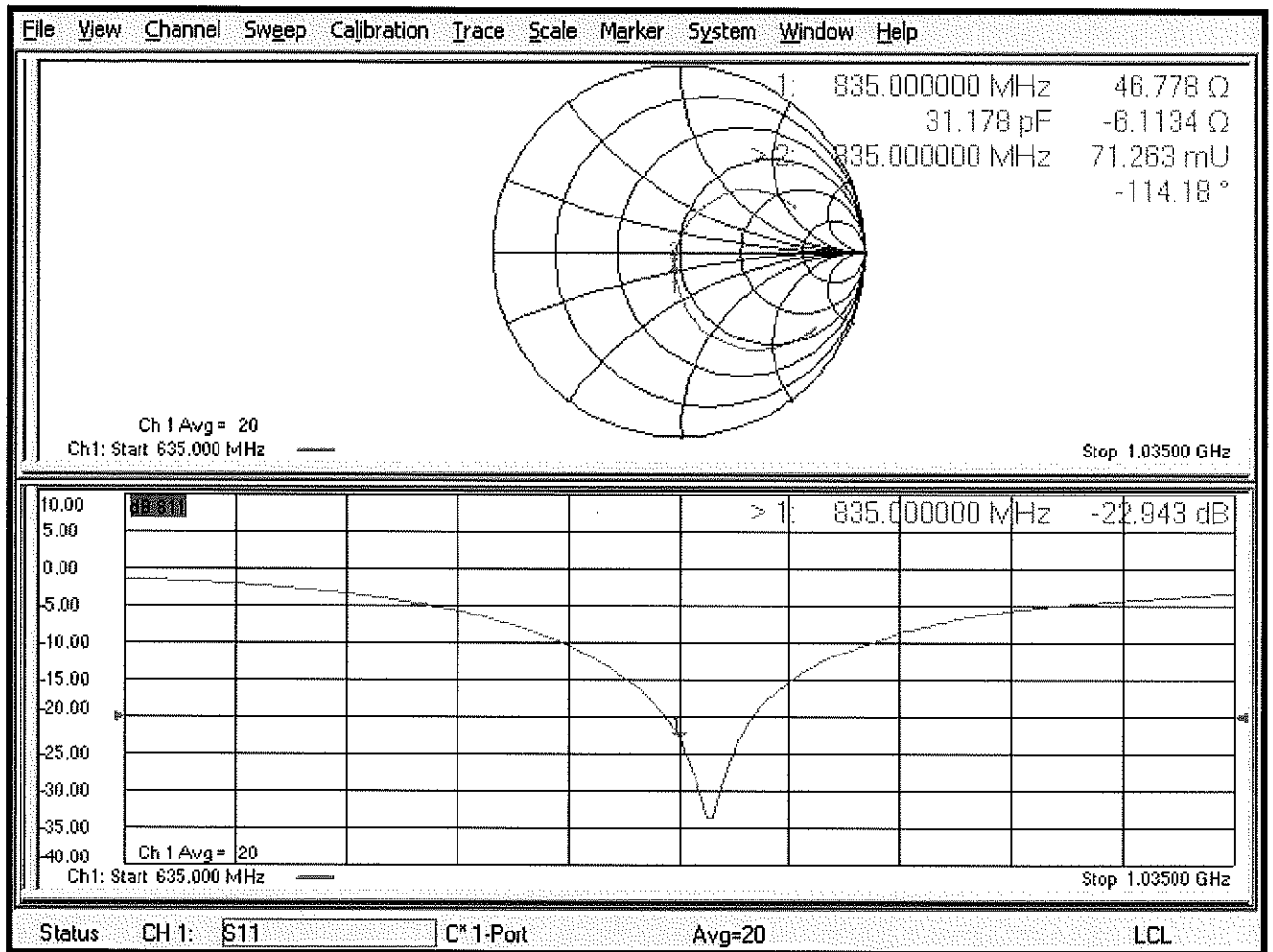



Accredited by the Swiss Accreditation Service (SAS)
The Swiss Accreditation Service is one of the signatories to the EA
Multilateral Agreement for the recognition of calibration certificates

Accreditation No.: **SCS 0108**

Client **PC Test**

Certificate No: **D1765V2-1008_May18**

CALIBRATION CERTIFICATE

Object **D1765V2 - SN:1008**

Calibration procedure(s) **QA CAL-05.v10
Calibration procedure for dipole validation kits above 700 MHz**

Calibration date: **May 23, 2018**

BN ✓
7/16/2018
BN ✓
05/20/2019

This calibration certificate documents the traceability to national standards, which realize the physical units of measurements (SI).
The measurements and the uncertainties with confidence probability are given on the following pages and are part of the certificate.

All calibrations have been conducted in the closed laboratory facility: environment temperature (22 ± 3)°C and humidity < 70%.

Calibration Equipment used (M&TE critical for calibration)

Primary Standards	ID #	Cal Date (Certificate No.)	Scheduled Calibration
Power meter NRP	SN: 104778	04-Apr-18 (No. 217-02672/02673)	Apr-19
Power sensor NRP-Z91	SN: 103244	04-Apr-18 (No. 217-02672)	Apr-19
Power sensor NRP-Z91	SN: 103245	04-Apr-18 (No. 217-02673)	Apr-19
Reference 20 dB Attenuator	SN: 5058 (20k)	04-Apr-18 (No. 217-02682)	Apr-19
Type-N mismatch combination	SN: 5047.2 / 06327	04-Apr-18 (No. 217-02683)	Apr-19
Reference Probe EX3DV4	SN: 7349	30-Dec-17 (No. EX3-7349_Dec17)	Dec-18
DAE4	SN: 601	26-Oct-17 (No. DAE4-601_Oct17)	Oct-18

Secondary Standards	ID #	Check Date (in house)	Scheduled Check
Power meter EPM-442A	SN: GB37480704	07-Oct-15 (in house check Oct-16)	In house check: Oct-18
Power sensor HP 8481A	SN: US37292783	07-Oct-15 (in house check Oct-16)	In house check: Oct-18
Power sensor HP 8481A	SN: MY41092317	07-Oct-15 (in house check Oct-16)	In house check: Oct-18
RF generator R&S SMT-06	SN: 100972	15-Jun-15 (in house check Oct-16)	In house check: Oct-18
Network Analyzer HP 8753E	SN: US37390585	18-Oct-01 (in house check Oct-17)	In house check: Oct-18

Calibrated by:	Name Manu Seitz	Function Laboratory Technician	Signature
Approved by:	Katja Pokovic	Technical Manager	

Issued: May 23, 2018

This calibration certificate shall not be reproduced except in full without written approval of the laboratory.



Accredited by the Swiss Accreditation Service (SAS)
The Swiss Accreditation Service is one of the signatories to the EA
Multilateral Agreement for the recognition of calibration certificates

Accreditation No.: **SCS 0108**

Glossary:

TSL	tissue simulating liquid
ConvF	sensitivity in TSL / NORM x,y,z
N/A	not applicable or not measured

Calibration is Performed According to the Following Standards:

- IEEE Std 1528-2013, "IEEE Recommended Practice for Determining the Peak Spatial-Averaged Specific Absorption Rate (SAR) in the Human Head from Wireless Communications Devices: Measurement Techniques", June 2013
- IEC 62209-1, "Measurement procedure for the assessment of Specific Absorption Rate (SAR) from hand-held and body-mounted devices used next to the ear (frequency range of 300 MHz to 6 GHz)", July 2016
- IEC 62209-2, "Procedure to determine the Specific Absorption Rate (SAR) for wireless communication devices used in close proximity to the human body (frequency range of 30 MHz to 6 GHz)", March 2010
- KDB 865664, "SAR Measurement Requirements for 100 MHz to 6 GHz"

Additional Documentation:

- DASY4/5 System Handbook

Methods Applied and Interpretation of Parameters:

- Measurement Conditions:** Further details are available from the Validation Report at the end of the certificate. All figures stated in the certificate are valid at the frequency indicated.
- Antenna Parameters with TSL:** The dipole is mounted with the spacer to position its feed point exactly below the center marking of the flat phantom section, with the arms oriented parallel to the body axis.
- Feed Point Impedance and Return Loss:** These parameters are measured with the dipole positioned under the liquid filled phantom. The impedance stated is transformed from the measurement at the SMA connector to the feed point. The Return Loss ensures low reflected power. No uncertainty required.
- Electrical Delay:** One-way delay between the SMA connector and the antenna feed point. No uncertainty required.
- SAR measured:** SAR measured at the stated antenna input power.
- SAR normalized:** SAR as measured, normalized to an input power of 1 W at the antenna connector.
- SAR for nominal TSL parameters:** The measured TSL parameters are used to calculate the nominal SAR result.

The reported uncertainty of measurement is stated as the standard uncertainty of measurement multiplied by the coverage factor $k=2$, which for a normal distribution corresponds to a coverage probability of approximately 95%.

Measurement Conditions

DASY system configuration, as far as not given on page 1.

DASY Version	DASY5	V52.10.1
Extrapolation	Advanced Extrapolation	
Phantom	Modular Flat Phantom	
Distance Dipole Center - TSL	10 mm	with Spacer
Zoom Scan Resolution	dx, dy, dz = 5.0 mm	
Frequency	1750 MHz \pm 1 MHz	

Head TSL parameters

The following parameters and calculations were applied.

	Temperature	Permittivity	Conductivity
Nominal Head TSL parameters	22.0 °C	40.1	1.37 mho/m
Measured Head TSL parameters	(22.0 \pm 0.2) °C	39.0 \pm 6 %	1.34 mho/m \pm 6 %
Head TSL temperature change during test	< 0.5 °C	----	----

SAR result with Head TSL

SAR averaged over 1 cm³ (1 g) of Head TSL	Condition	
SAR measured	250 mW input power	8.94 W/kg
SAR for nominal Head TSL parameters	normalized to 1W	36.2 W/kg \pm 17.0 % (k=2)

SAR averaged over 10 cm³ (10 g) of Head TSL	condition	
SAR measured	250 mW input power	4.71 W/kg
SAR for nominal Head TSL parameters	normalized to 1W	19.0 W/kg \pm 16.5 % (k=2)

Body TSL parameters

The following parameters and calculations were applied.

	Temperature	Permittivity	Conductivity
Nominal Body TSL parameters	22.0 °C	53.4	1.49 mho/m
Measured Body TSL parameters	(22.0 \pm 0.2) °C	53.2 \pm 6 %	1.46 mho/m \pm 6 %
Body TSL temperature change during test	< 0.5 °C	----	----

SAR result with Body TSL

SAR averaged over 1 cm³ (1 g) of Body TSL	Condition	
SAR measured	250 mW input power	9.21 W/kg
SAR for nominal Body TSL parameters	normalized to 1W	37.4 W/kg \pm 17.0 % (k=2)

SAR averaged over 10 cm³ (10 g) of Body TSL	condition	
SAR measured	250 mW input power	4.92 W/kg
SAR for nominal Body TSL parameters	normalized to 1W	19.9 W/kg \pm 16.5 % (k=2)

Appendix (Additional assessments outside the scope of SCS 0108)

Antenna Parameters with Head TSL

Impedance, transformed to feed point	47.7 Ω - 6.5 j Ω
Return Loss	- 23.0 dB

Antenna Parameters with Body TSL

Impedance, transformed to feed point	43.3 Ω - 6.0 j Ω
Return Loss	- 20.3 dB

General Antenna Parameters and Design

Electrical Delay (one direction)	1.210 ns
----------------------------------	----------

After long term use with 100W radiated power, only a slight warming of the dipole near the feedpoint can be measured.

The dipole is made of standard semirigid coaxial cable. The center conductor of the feeding line is directly connected to the second arm of the dipole. The antenna is therefore short-circuited for DC-signals. On some of the dipoles, small end caps are added to the dipole arms in order to improve matching when loaded according to the position as explained in the "Measurement Conditions" paragraph. The SAR data are not affected by this change. The overall dipole length is still according to the Standard.

No excessive force must be applied to the dipole arms, because they might bend or the soldered connections near the feedpoint may be damaged.

Additional EUT Data

Manufactured by	SPEAG
Manufactured on	October 06, 2005

Appendix (Additional assessments outside the scope of SCS 0108)

Measurement Conditions

DASY system configuration, as far as not given on page 1 and 3.

Phantom	SAM Head Phantom	For usage with cSAR3DV2-R/L
---------	------------------	-----------------------------

SAR result with SAM Head (Top)

SAR averaged over 1 cm ³ (1 g) of Head TSL	Condition	
SAR measured	250 mW input power	9.26 W/kg
SAR for nominal Head TSL parameters	normalized to 1W	37.4 W/kg ± 17.5 % (k=2)

SAR averaged over 10 cm ³ (10 g) of Head TSL	condition	
SAR measured	250 mW input power	4.95 W/kg
SAR for nominal Head TSL parameters	normalized to 1W	19.9 W/kg ± 16.9 % (k=2)

SAR result with SAM Head (Mouth)

SAR averaged over 1 cm ³ (1 g) of Head TSL	Condition	
SAR measured	250 mW input power	9.47 W/kg
SAR for nominal Head TSL parameters	normalized to 1W	38.2 W/kg ± 17.5 % (k=2)

SAR averaged over 10 cm ³ (10 g) of Head TSL	condition	
SAR measured	250 mW input power	5.06 W/kg
SAR for nominal Head TSL parameters	normalized to 1W	20.4 W/kg ± 16.9 % (k=2)

SAR result with SAM Head (Neck)

SAR averaged over 1 cm ³ (1 g) of Head TSL	Condition	
SAR measured	250 mW input power	9.26 W/kg
SAR for nominal Head TSL parameters	normalized to 1W	37.4 W/kg ± 17.5 % (k=2)

SAR averaged over 10 cm ³ (10 g) of Head TSL	condition	
SAR measured	250 mW input power	5.02 W/kg
SAR for nominal Head TSL parameters	normalized to 1W	20.2 W/kg ± 16.9 % (k=2)

SAR result with SAM Head (Ear)

SAR averaged over 1 cm ³ (1 g) of Head TSL	Condition	
SAR measured	250 mW input power	7.12 W/kg
SAR for nominal Head TSL parameters	normalized to 1W	28.7 W/kg ± 17.5 % (k=2)

SAR averaged over 10 cm ³ (10 g) of Head TSL	condition	
SAR measured	250 mW input power	4.01 W/kg
SAR for nominal Head TSL parameters	normalized to 1W	16.1 W/kg ± 16.9 % (k=2)

DASY5 Validation Report for Head TSL

Date: 15.05.2018

Test Laboratory: SPEAG, Zurich, Switzerland

DUT: Dipole 1765 MHz; Type: D1765V2; Serial: D1765V2 - SN:1008

Communication System: UID 0 - CW; Frequency: 1750 MHz

Medium parameters used: $f = 1750$ MHz; $\sigma = 1.34$ S/m; $\epsilon_r = 39$; $\rho = 1000$ kg/m³

Phantom section: Flat Section

Measurement Standard: DASY5 (IEEE/IEC/ANSI C63.19-2011)

DASY52 Configuration:

- Probe: EX3DV4 - SN7349; ConvF(8.5, 8.5, 8.5) @ 1750 MHz; Calibrated: 30.12.2017
- Sensor-Surface: 1.4mm (Mechanical Surface Detection)
- Electronics: DAE4 Sn601; Calibrated: 26.10.2017
- Phantom: Flat Phantom 5.0 (front); Type: QD 000 P50 AA; Serial: 1001
- DASY52 52.10.1(1476); SEMCAD X 14.6.11(7439)

Dipole Calibration for Head Tissue/Pin=250 mW, d=10mm/Zoom Scan (7x7x7)/Cube 0:

Measurement grid: dx=5mm, dy=5mm, dz=5mm

Reference Value = 106.6 V/m; Power Drift = -0.02 dB

Peak SAR (extrapolated) = 16.4 W/kg

SAR(1 g) = 8.94 W/kg; SAR(10 g) = 4.71 W/kg

Maximum value of SAR (measured) = 13.8 W/kg

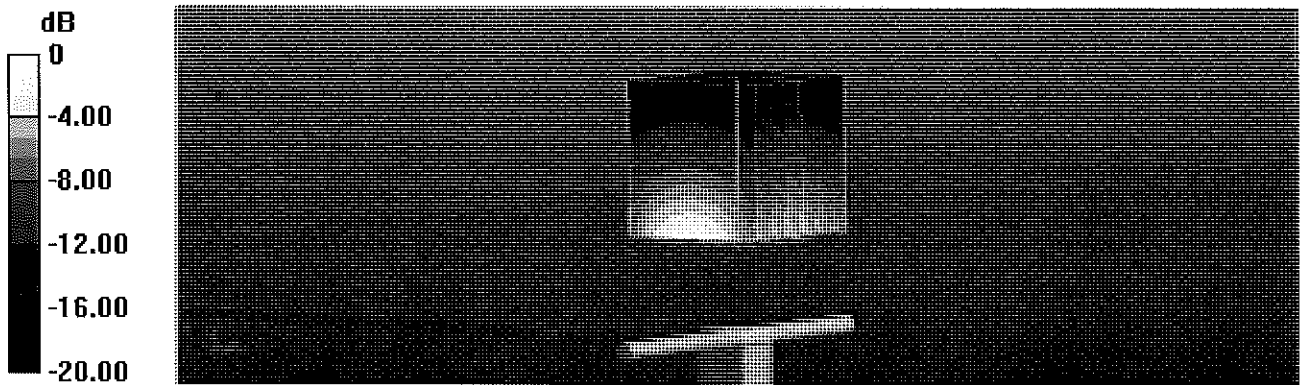

Impedance Measurement Plot for Head TSL

15 May 2018 11:19:20

CH1 S11 1 U FS 1: 47.658 Ω -6.5039 Ω 13.983 pF 1 750.000 000 MHz

*
De1
CA
Avg
16
H1d

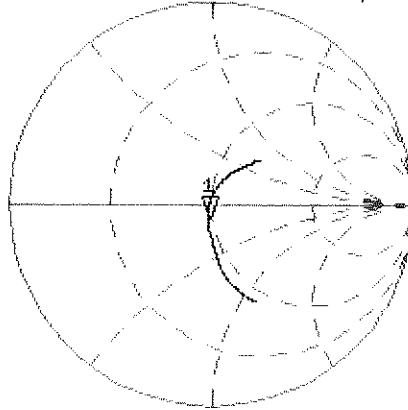

CH2 S11 LOG 5 dB/REF -20 dB 1:-23.017 dB 1 750.000 000 MHz

CA
Avg
16
H1d

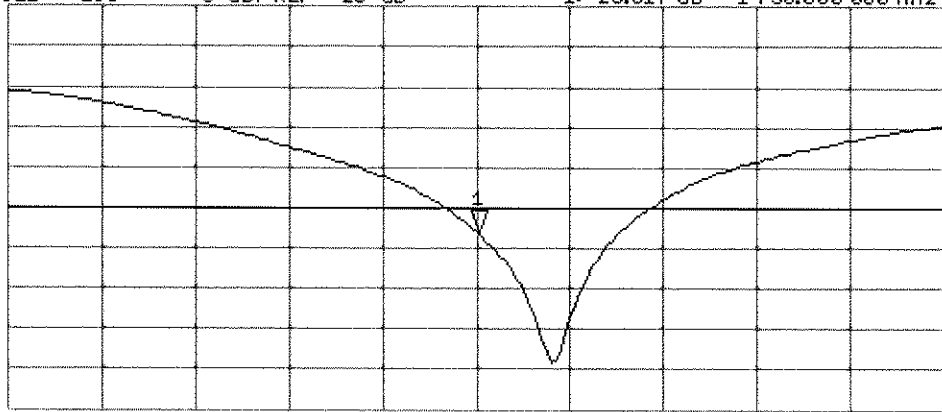

START 1 550.000 000 MHz

STOP 1 950.000 000 MHz

DASY5 Validation Report for Body TSL

Date: 15.05.2018

Test Laboratory: SPEAG, Zurich, Switzerland

DUT: Dipole 1765 MHz; Type: D1765V2; Serial: D1765V2 - SN:1008

Communication System: UID 0 - CW; Frequency: 1750 MHz

Medium parameters used: $f = 1750$ MHz; $\sigma = 1.46$ S/m; $\epsilon_r = 53.2$; $\rho = 1000$ kg/m³

Phantom section: Flat Section

Measurement Standard: DASY5 (IEEE/IEC/ANSI C63.19-2011)

DASY52 Configuration:

- Probe: EX3DV4 - SN7349; ConvF(8.35, 8.35, 8.35) @ 1750 MHz; Calibrated: 30.12.2017
- Sensor-Surface: 1.4mm (Mechanical Surface Detection)
- Electronics: DAE4 Sn601; Calibrated: 26.10.2017
- Phantom: Flat Phantom 5.0 (back); Type: QD 000 P50 AA; Serial: 1002
- DASY52 52.10.1(1476); SEMCAD X 14.6.11(7439)

Dipole Calibration for Body Tissue/Pin=250 mW, d=10mm/Zoom Scan (7x7x7)/Cube 0:

Measurement grid: dx=5mm, dy=5mm, dz=5mm

Reference Value = 102.4 V/m; Power Drift = -0.06 dB

Peak SAR (extrapolated) = 16.1 W/kg

SAR(1 g) = 9.21 W/kg; SAR(10 g) = 4.92 W/kg

Maximum value of SAR (measured) = 13.7 W/kg

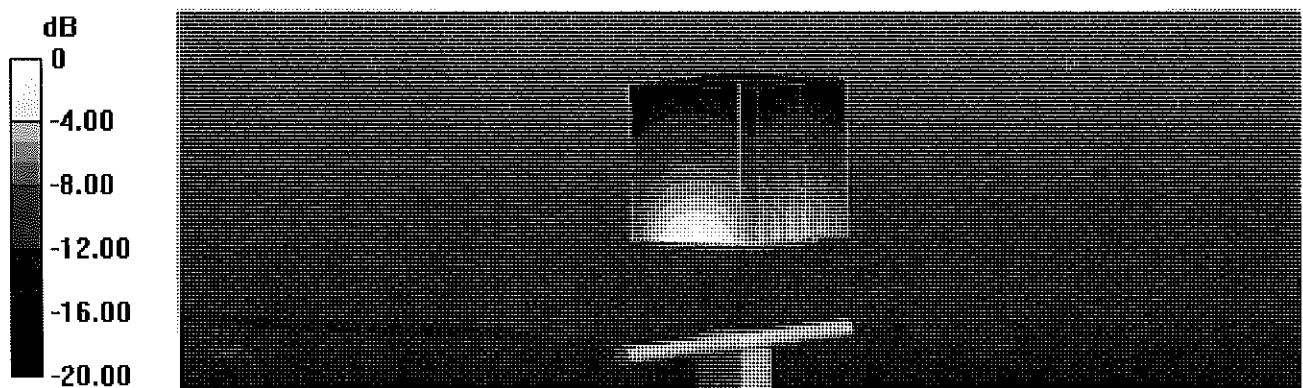

Impedance Measurement Plot for Body TSL

15 May 2018 11:18:17

CH1 S11 1 U FS 1: 43.322 Ω -6.0117 Ω 15.128 pF 1 750.000 000 MHz

*
De1
CA
Avg
16
HI d

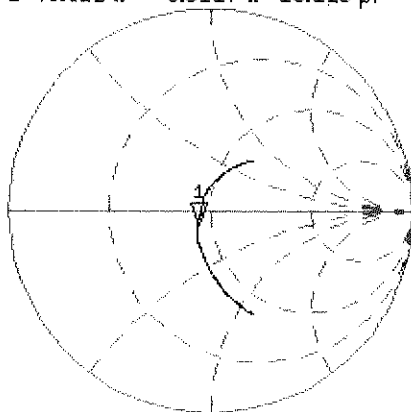

CH2 S11 LOG 5 dB/REF -20 dB 1:-20.349 dB 1 750.000 000 MHz

CA
Avg
16
HI d

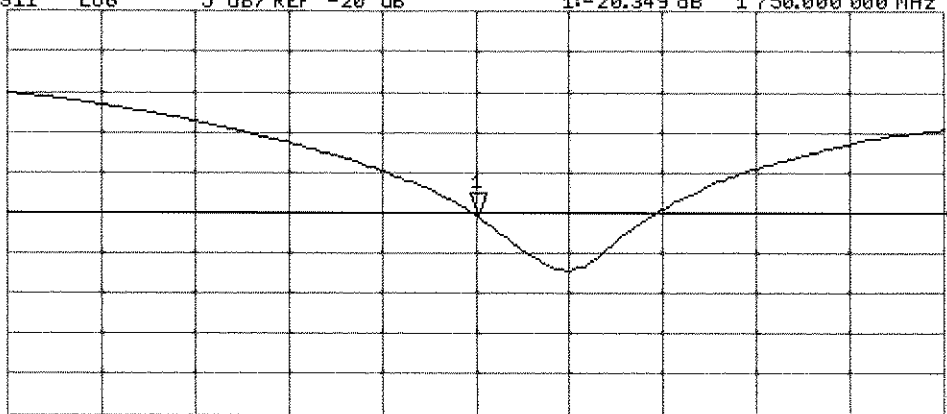

START 1 550.000 000 MHz

STOP 1 950.000 000 MHz

DASY5 Validation Report for SAM Head

Date: 23.05.2018

Test Laboratory: SPEAG, Zurich, Switzerland

DUT: Dipole 1765 MHz; Type: D1765V2; Serial: D1765V2 - SN:1008

Communication System: UID 0 - CW; Frequency: 1750 MHz

Medium parameters used: $f = 1750$ MHz; $\sigma = 1.37$ S/m; $\epsilon_r = 41.8$; $\rho = 1000$ kg/m³

Measurement Standard: DASY5 (IEEE/IEC/ANSI C63.19-2011)

DASY52 Configuration:

- Probe: EX3DV4 - SN7349; ConvF(8.5, 8.5, 8.5) @ 1750 MHz; Calibrated: 30.12.2017
- Sensor-Surface: 1.4mm (Mechanical Surface Detection)
- Electronics: DAE4 Sn601; Calibrated: 26.10.2017
- Phantom: SAM Head
- DASY52 52.10.1(1476); SEMCAD X 14.6.11(7439)

SAM/Head/Top/Zoom Scan (7x7x7)/Cube 0: Measurement grid: dx=5mm, dy=5mm, dz=5mm

Reference Value = 105.8 V/m; Power Drift = 0.02 dB

Peak SAR (extrapolated) = 16.4 W/kg

SAR(1 g) = 9.26 W/kg; SAR(10 g) = 4.95 W/kg

Maximum value of SAR (measured) = 13.9 W/kg

SAM/Head/Mouth/Zoom Scan (7x7x7)/Cube 0: Measurement grid: dx=5mm, dy=5mm, dz=5mm

Reference Value = 104.2 V/m; Power Drift = -0.04 dB

Peak SAR (extrapolated) = 16.6 W/kg

SAR(1 g) = 9.47 W/kg; SAR(10 g) = 5.06 W/kg

Maximum value of SAR (measured) = 13.7 W/kg

SAM/Head/Neck/Zoom Scan (7x7x7)/Cube 0: Measurement grid: dx=5mm, dy=5mm, dz=5mm

Reference Value = 104.7 V/m; Power Drift = 0.02 dB

Peak SAR (extrapolated) = 15.8 W/kg

SAR(1 g) = 9.26 W/kg; SAR(10 g) = 5.02 W/kg

Maximum value of SAR (measured) = 13.8 W/kg

SAM/Head/Ear/Zoom Scan (7x7x7)/Cube 0: Measurement grid: dx=5mm, dy=5mm, dz=5mm

Reference Value = 90.46 V/m; Power Drift = -0.02 dB

Peak SAR (extrapolated) = 11.8 W/kg

SAR(1 g) = 7.12 W/kg; SAR(10 g) = 4.01 W/kg

Maximum value of SAR (measured) = 10.3 W/kg

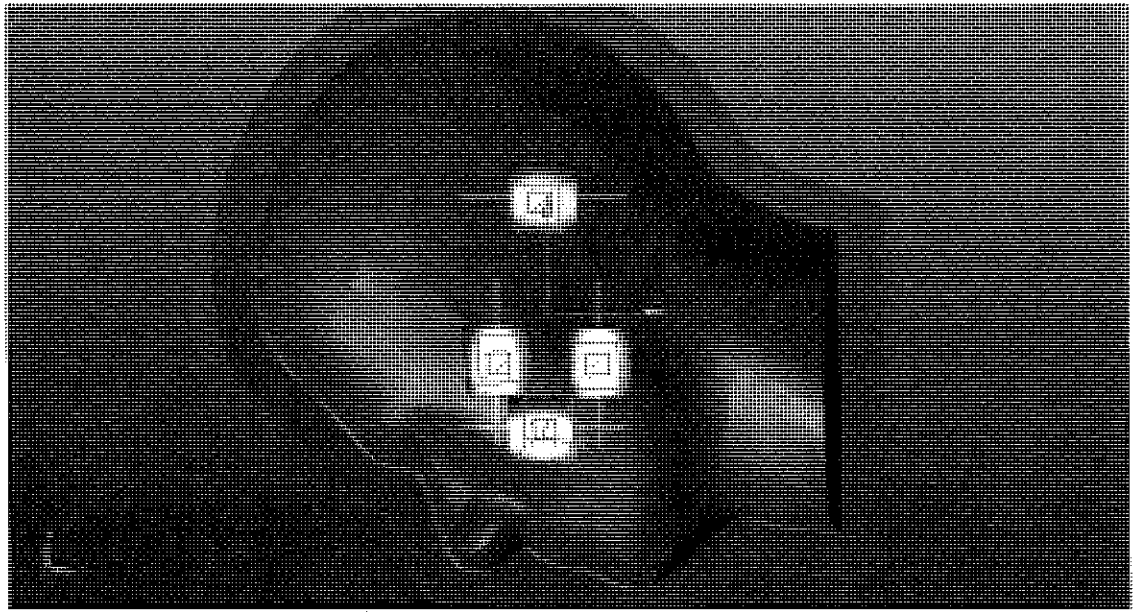
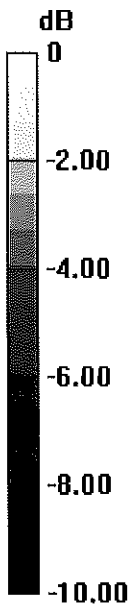

0 dB = 10.3 W/kg = 10.13 dBW/kg

Certification of Calibration

Object: D1765V2 – SN: 1008

Calibration procedure(s): Procedure for Calibration Extension for SAR Dipoles.

Extension Calibration date: 5/17/2019

Description: SAR Validation Dipole at 1750 MHz.

Calibration Equipment used:

Manufacturer	Model	Description	Cal Date	Cal Interval	Cal Due	Serial Number
Agilent	8753ES	S-Parameter Network Analyzer	3/11/2019	Annual	3/11/2020	US39170122
Agilent	N5182A	MXG Vector Signal Generator	11/28/2018	Annual	11/28/2019	MY47420603
Amplifier Research	15S1G6	Amplifier	CBT	N/A	CBT	433971
Anritsu	MA2411B	Pulse Power Sensor	11/20/2018	Annual	11/20/2019	1027293
Anritsu	MA2411B	Pulse Power Sensor	10/30/2018	Annual	10/30/2019	1126066
Anritsu	ML2495A	Power Meter	10/21/2018	Annual	10/21/2019	941001
Control Company	4040	Therm./ Clock/ Humidity Monitor	10/9/2018	Biennial	10/9/2020	181647811
Control Company	4352	Ultra Long Stem Thermometer	6/6/2018	Biennial	6/6/2020	181334678
Keysight	772D	Dual Directional Coupler	CBT	N/A	CBT	MY52180215
Keysight Technologies	85033E	Standard Mechanical Calibration Kit (DC to 9GHz, 3.5mm)	6/4/2018	Annual	6/4/2019	MY53401181
MiniCircuits	VLF-6000+	Low Pass Filter	CBT	N/A	CBT	N/A
Mini-Circuits	BW-N20W5+	DC to 18 GHz Precision Fixed 20 dB Attenuator	CBT	N/A	CBT	N/A
Narda	4772-3	Attenuator (3dB)	CBT	N/A	CBT	9406
Pasternack	PE2209-10	Bidirectional Coupler	CBT	N/A	CBT	N/A
Seekonk	NC-100	Torque Wrench	7/11/2018	Annual	7/11/2019	N/A
SPEAG	EX3DV4	SAR Probe	6/25/2018	Annual	6/25/2019	7409
SPEAG	DAE4	Dasy Data Acquisition Electronics	6/18/2018	Annual	6/18/2019	1334
SPEAG	EX3DV4	SAR Probe	2/19/2019	Annual	2/19/2020	3914
SPEAG	DAE4	Dasy Data Acquisition Electronics	2/14/2019	Annual	2/14/2020	1272
SPEAG	DAK-3.5	Dielectric Assessment Kit	9/11/2018	Annual	9/11/2019	1091

Measurement Uncertainty = $\pm 23\%$ (k=2)

	Name	Function	Signature
Calibrated By:	Brodie Halfoster	Test Engineer	<i>BRODIE HALFOSTER</i>
Approved By:	Kaitlin O'Keefe	Senior Technical Manager	<i>KOK</i>

DIPOLE CALIBRATION EXTENSION

Per KDB 865664 D01, calibration intervals of up to three years may be considered for reference dipoles when it is demonstrated that the SAR target, impedance and return loss of a dipole have remained stable according to the following requirements:

1. The measured SAR does not deviate more than 10% from the target on the calibration certificate.
2. The return-loss does not deviate more than 20% from the previous measurement and meets the required 20dB minimum return-loss requirement.
3. The measurement of real or imaginary parts of impedance does not deviate more than 5Ω from the previous measurement.

The following dipole was checked to pass the above 3 requirements to have 2-year calibration period from the calibration date:

Calibration Date	Extension Date	Certificate Electrical Delay (ns)	Certificate SAR Target Head (1g) W/kg @ 20.0 dBm	Measured Head SAR (1g) W/kg @ 20.0 dBm	Deviation 1g (%)	Certificate SAR Target Head (10g) W/kg @ 20.0 dBm	Measured Head SAR (10g) W/kg @ 20.0 dBm	Deviation 10g (%)	Certificate Impedance Head (Ohm) Real	Measured Impedance Head (Ohm) Real	Difference (Ohm) Real	Certificate Impedance Head (Ohm) Imaginary	Measured Impedance Head (Ohm) Imaginary	Difference (Ohm) Imaginary	Certificate Return Loss Head (dB)	Measured Return Loss Head (dB)	Deviation (%)	PASS/FAIL
5/23/2019	5/17/2019	1.21	3.62	3.63	0.28%	1.9	1.92	1.05%	47.7	47	0.7	-6.5	-6	0.5	-23	-23.3	-1.20%	PASS
Calibration Date	Extension Date	Certificate Electrical Delay (ns)	Certificate SAR Target Body (1g) W/kg @ 20.0 dBm	Measured Body SAR (1g) W/kg @ 20.0 dBm	Deviation 1g (%)	Certificate SAR Target Body (10g) W/kg @ 20.0 dBm	Measured Body SAR (10g) W/kg @ 20.0 dBm	Deviation 10g (%)	Certificate Impedance Body (Ohm) Real	Measured Impedance Body (Ohm) Real	Difference (Ohm) Real	Certificate Impedance Body (Ohm) Imaginary	Measured Impedance Body (Ohm) Imaginary	Difference (Ohm) Imaginary	Certificate Return Loss Body (dB)	Measured Return Loss Body (dB)	Deviation (%)	PASS/FAIL
5/23/2019	5/17/2019	1.21	3.74	3.95	5.61%	1.99	2.08	4.52%	43.3	44.6	1.3	-6	-7	1	-20.3	-20.5	-0.90%	PASS

Impedance & Return-Loss Measurement Plot for Head TSL

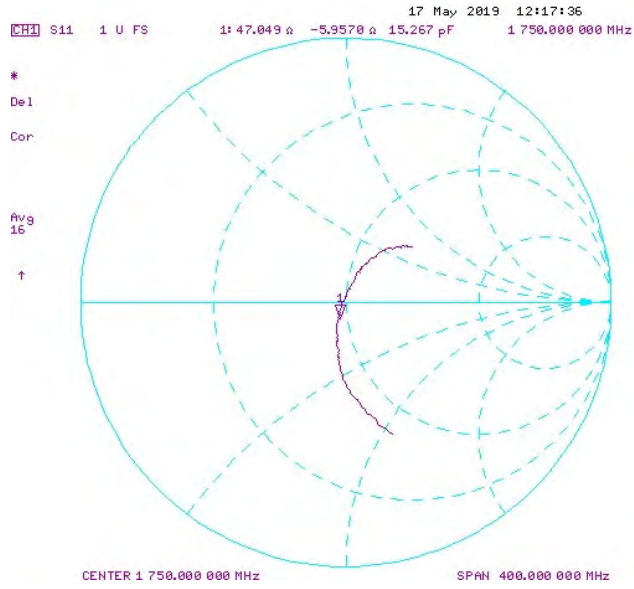

Impedance & Return-Loss Measurement Plot for Body TSL

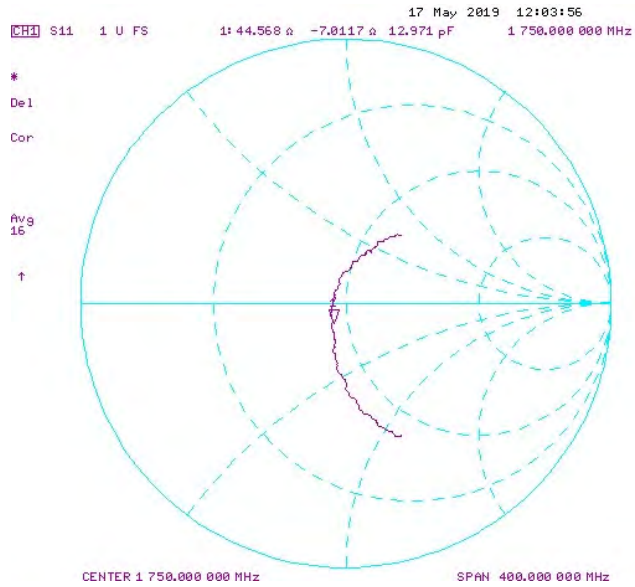



Accredited by the Swiss Accreditation Service (SAS)
The Swiss Accreditation Service is one of the signatories to the EA
Multilateral Agreement for the recognition of calibration certificates

Accreditation No.: **SCS 0108**

Client **PC Test**

Certificate No: **D1750V2-1148_May19**

CALIBRATION CERTIFICATE

Object **D1750V2 - SN:1148**

Calibration procedure(s) **QA CAL-05.v11
Calibration Procedure for SAR Validation Sources between 0.7-3 GHz**

Calibration date: **May 15, 2019**

*BNW
05-23-2019*

This calibration certificate documents the traceability to national standards, which realize the physical units of measurements (SI).
The measurements and the uncertainties with confidence probability are given on the following pages and are part of the certificate.

All calibrations have been conducted in the closed laboratory facility: environment temperature (22 ± 3)°C and humidity < 70%.

Calibration Equipment used (M&TE critical for calibration)

Primary Standards	ID #	Cal Date (Certificate No.)	Scheduled Calibration
Power meter NRP	SN: 104778	03-Apr-19 (No. 217-02892/02893)	Apr-20
Power sensor NRP-Z91	SN: 103244	03-Apr-19 (No. 217-02892)	Apr-20
Power sensor NRP-Z91	SN: 103245	03-Apr-19 (No. 217-02893)	Apr-20
Reference 20 dB Attenuator	SN: 5058 (20k)	04-Apr-19 (No. 217-02894)	Apr-20
Type-N mismatch combination	SN: 5047.2 / 06327	04-Apr-19 (No. 217-02895)	Apr-20
Reference Probe EX3DV4	SN: 7349	31-Dec-18 (No. EX3-7349_Dec18)	Dec-19
DAE4	SN: 601	30-Apr-19 (No. DAE4-601_Apr19)	Apr-20
Secondary Standards	ID #	Check Date (in house)	Scheduled Check
Power meter E4419B	SN: GB39512475	30-Oct-14 (in house check Feb-19)	In house check: Oct-20
Power sensor HP 8481A	SN: US37292783	07-Oct-15 (in house check Oct-18)	In house check: Oct-20
Power sensor HP 8481A	SN: MY41092317	07-Oct-15 (in house check Oct-18)	In house check: Oct-20
RF generator R&S SMT-06	SN: 100972	15-Jun-15 (in house check Oct-18)	In house check: Oct-20
Network Analyzer Agilent E8358A	SN: US41080477	31-Mar-14 (in house check Oct-18)	In house check: Oct-19

Calibrated by:	Name Leif Klysner	Function Laboratory Technician	Signature
Approved by:	Name Katja Pokovic	Technical Manager	

Issued: May 15, 2019

This calibration certificate shall not be reproduced except in full without written approval of the laboratory.



Accredited by the Swiss Accreditation Service (SAS)
The Swiss Accreditation Service is one of the signatories to the EA
Multilateral Agreement for the recognition of calibration certificates

Accreditation No.: **SCS 0108**

Glossary:

TSL	tissue simulating liquid
ConvF	sensitivity in TSL / NORM x,y,z
N/A	not applicable or not measured

Calibration is Performed According to the Following Standards:

- a) IEEE Std 1528-2013, "IEEE Recommended Practice for Determining the Peak Spatial-Averaged Specific Absorption Rate (SAR) in the Human Head from Wireless Communications Devices: Measurement Techniques", June 2013
- b) IEC 62209-1, "Measurement procedure for the assessment of Specific Absorption Rate (SAR) from hand-held and body-mounted devices used next to the ear (frequency range of 300 MHz to 6 GHz)", July 2016
- c) IEC 62209-2, "Procedure to determine the Specific Absorption Rate (SAR) for wireless communication devices used in close proximity to the human body (frequency range of 30 MHz to 6 GHz)", March 2010
- d) KDB 865664, "SAR Measurement Requirements for 100 MHz to 6 GHz"

Additional Documentation:

- e) DASY4/5 System Handbook

Methods Applied and Interpretation of Parameters:

- *Measurement Conditions:* Further details are available from the Validation Report at the end of the certificate. All figures stated in the certificate are valid at the frequency indicated.
- *Antenna Parameters with TSL:* The dipole is mounted with the spacer to position its feed point exactly below the center marking of the flat phantom section, with the arms oriented parallel to the body axis.
- *Feed Point Impedance and Return Loss:* These parameters are measured with the dipole positioned under the liquid filled phantom. The impedance stated is transformed from the measurement at the SMA connector to the feed point. The Return Loss ensures low reflected power. No uncertainty required.
- *Electrical Delay:* One-way delay between the SMA connector and the antenna feed point. No uncertainty required.
- *SAR measured:* SAR measured at the stated antenna input power.
- *SAR normalized:* SAR as measured, normalized to an input power of 1 W at the antenna connector.
- *SAR for nominal TSL parameters:* The measured TSL parameters are used to calculate the nominal SAR result.

The reported uncertainty of measurement is stated as the standard uncertainty of measurement multiplied by the coverage factor $k=2$, which for a normal distribution corresponds to a coverage probability of approximately 95%.

Measurement Conditions

DASY system configuration, as far as not given on page 1.

DASY Version	DASY5	V52.10.2
Extrapolation	Advanced Extrapolation	
Phantom	Modular Flat Phantom	
Distance Dipole Center - TSL	10 mm	with Spacer
Zoom Scan Resolution	dx, dy, dz = 5.0 mm	
Frequency	1750 MHz \pm 1 MHz	

Head TSL parameters

The following parameters and calculations were applied.

	Temperature	Permittivity	Conductivity
Nominal Head TSL parameters	22.0 °C	40.1	1.37 mho/m
Measured Head TSL parameters	(22.0 \pm 0.2) °C	40.0 \pm 6 %	1.34 mho/m \pm 6 %
Head TSL temperature change during test	< 0.5 °C	---	----

SAR result with Head TSL

SAR averaged over 1 cm ³ (1 g) of Head TSL	Condition	
SAR measured	250 mW input power	9.13 W/kg
SAR for nominal Head TSL parameters	normalized to 1W	37.0 W/kg \pm 17.0 % (k=2)

SAR averaged over 10 cm ³ (10 g) of Head TSL	condition	
SAR measured	250 mW input power	4.83 W/kg
SAR for nominal Head TSL parameters	normalized to 1W	19.5 W/kg \pm 16.5 % (k=2)

Body TSL parameters

The following parameters and calculations were applied.

	Temperature	Permittivity	Conductivity
Nominal Body TSL parameters	22.0 °C	53.4	1.49 mho/m
Measured Body TSL parameters	(22.0 \pm 0.2) °C	53.5 \pm 6 %	1.47 mho/m \pm 6 %
Body TSL temperature change during test	< 0.5 °C	---	----

SAR result with Body TSL

SAR averaged over 1 cm ³ (1 g) of Body TSL	Condition	
SAR measured	250 mW input power	9.35 W/kg
SAR for nominal Body TSL parameters	normalized to 1W	37.7 W/kg \pm 17.0 % (k=2)

SAR averaged over 10 cm ³ (10 g) of Body TSL	condition	
SAR measured	250 mW input power	4.93 W/kg
SAR for nominal Body TSL parameters	normalized to 1W	19.8 W/kg \pm 16.5 % (k=2)

Appendix (Additional assessments outside the scope of SCS 0108)

Antenna Parameters with Head TSL

Impedance, transformed to feed point	51.4 Ω - 0.2 j Ω
Return Loss	- 37.0 dB

Antenna Parameters with Body TSL

Impedance, transformed to feed point	47.4 Ω - 0.5 j Ω
Return Loss	- 31.4 dB

General Antenna Parameters and Design

Electrical Delay (one direction)	1.222 ns
----------------------------------	----------

After long term use with 100W radiated power, only a slight warming of the dipole near the feedpoint can be measured.

The dipole is made of standard semirigid coaxial cable. The center conductor of the feeding line is directly connected to the second arm of the dipole. The antenna is therefore short-circuited for DC-signals. On some of the dipoles, small end caps are added to the dipole arms in order to improve matching when loaded according to the position as explained in the "Measurement Conditions" paragraph. The SAR data are not affected by this change. The overall dipole length is still according to the Standard.

No excessive force must be applied to the dipole arms, because they might bend or the soldered connections near the feedpoint may be damaged.

Additional EUT Data

Manufactured by	SPEAG
-----------------	-------

Appendix (Additional assessments outside the scope of SCS 0108)

Measurement Conditions

DASY system configuration, as far as not given on page 1 and 3.

Phantom	SAM Head Phantom	For usage with cSAR3DV2-R/L
---------	------------------	-----------------------------

SAR result with SAM Head (Top)

SAR averaged over 1 cm ³ (1 g) of Head TSL	Condition	
SAR measured	250 mW input power	9.38 W/kg
SAR for nominal Head TSL parameters	normalized to 1W	37.9 W/kg ± 17.5 % (k=2)

SAR averaged over 10 cm ³ (10 g) of Head TSL	condition	
SAR measured	250 mW input power	5.04 W/kg
SAR for nominal Head TSL parameters	normalized to 1W	20.3 W/kg ± 16.9 % (k=2)

SAR result with SAM Head (Mouth)

SAR averaged over 1 cm ³ (1 g) of Head TSL	Condition	
SAR measured	250 mW input power	9.34 W/kg
SAR for nominal Head TSL parameters	normalized to 1W	37.8 W/kg ± 17.5 % (k=2)

SAR averaged over 10 cm ³ (10 g) of Head TSL	condition	
SAR measured	250 mW input power	5.04 W/kg
SAR for nominal Head TSL parameters	normalized to 1W	20.3 W/kg ± 16.9 % (k=2)

SAR result with SAM Head (Neck)

SAR averaged over 1 cm ³ (1 g) of Head TSL	Condition	
SAR measured	250 mW input power	9.06 W/kg
SAR for nominal Head TSL parameters	normalized to 1W	36.6 W/kg ± 17.5 % (k=2)

SAR averaged over 10 cm ³ (10 g) of Head TSL	condition	
SAR measured	250 mW input power	4.95 W/kg
SAR for nominal Head TSL parameters	normalized to 1W	19.9 W/kg ± 16.9 % (k=2)

SAR result with SAM Head (Ear)

SAR averaged over 1 cm ³ (1 g) of Head TSL	Condition	
SAR measured	250 mW input power	7.11 W/kg
SAR for nominal Head TSL parameters	normalized to 1W	28.7 W/kg ± 17.5 % (k=2)

SAR averaged over 10 cm ³ (10 g) of Head TSL	condition	
SAR measured	250 mW input power	3.98 W/kg
SAR for nominal Head TSL parameters	normalized to 1W	16.0 W/kg ± 16.9 % (k=2)

DASY5 Validation Report for Head TSL

Date: 08.05.2019

Test Laboratory: SPEAG, Zurich, Switzerland

DUT: Dipole 1750 MHz; Type: D1750V2; Serial: D1750V2 - SN:1148

Communication System: UID 0 - CW; Frequency: 1750 MHz

Medium parameters used: $f = 1750$ MHz; $\sigma = 1.34$ S/m; $\epsilon_r = 40$; $\rho = 1000$ kg/m³

Phantom section: Flat Section

Measurement Standard: DASY5 (IEEE/IEC/ANSI C63.19-2011)

DASY52 Configuration:

- Probe: EX3DV4 - SN7349; ConvF(8.59, 8.59, 8.59) @ 1750 MHz; Calibrated: 31.12.2018
- Sensor-Surface: 1.4mm (Mechanical Surface Detection)
- Electronics: DAE4 Sn601; Calibrated: 30.04.2019
- Phantom: Flat Phantom 5.0 (front); Type: QD 000 P50 AA; Serial: 1001
- DASY52 52.10.2(1495); SEMCAD X 14.6.12(7450)

Dipole Calibration for Head Tissue/Pin=250 mW, d=10mm/Zoom Scan (7x7x7)/Cube 0:

Measurement grid: dx=5mm, dy=5mm, dz=5mm

Reference Value = 107.8 V/m; Power Drift = -0.01 dB

Peak SAR (extrapolated) = 16.7 W/kg

SAR(1 g) = 9.13 W/kg; SAR(10 g) = 4.83 W/kg

Maximum value of SAR (measured) = 14.1 W/kg

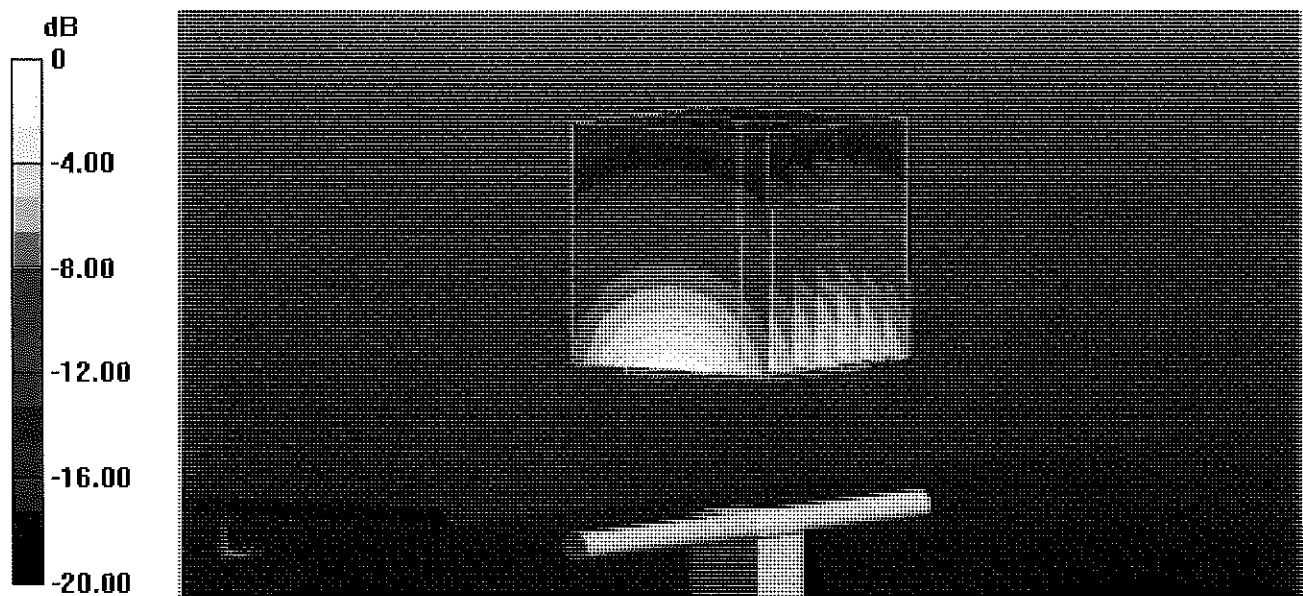

0 dB = 14.1 W/kg = 11.49 dBW/kg

Impedance Measurement Plot for Head TSL

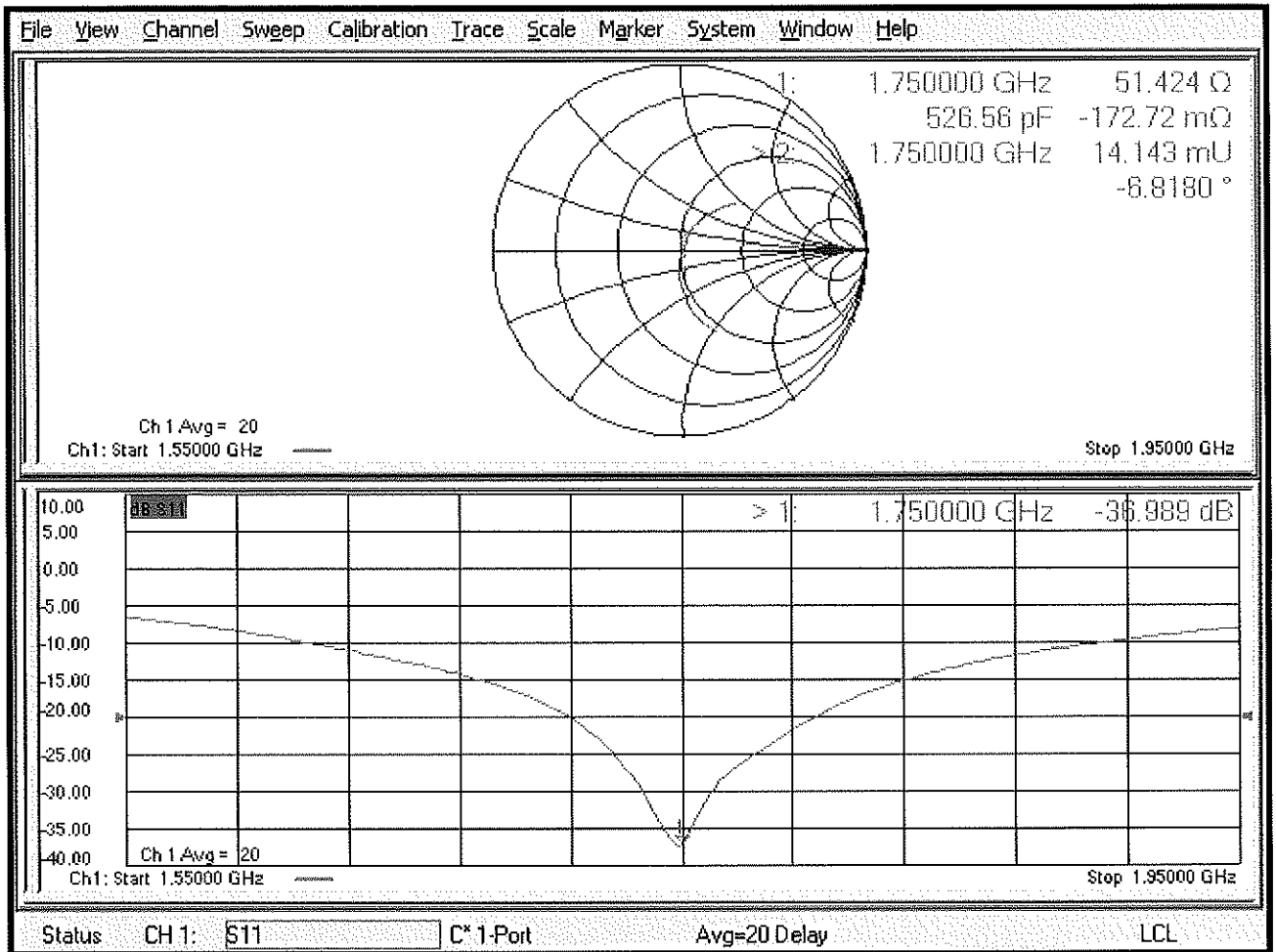

DASY5 Validation Report for Body TSL

Date: 08.05.2019

Test Laboratory: SPEAG, Zurich, Switzerland

DUT: Dipole 1750 MHz; Type: D1750V2; Serial: D1750V2 - SN:1148

Communication System: UID 0 - CW; Frequency: 1750 MHz

Medium parameters used: $f = 1750$ MHz; $\sigma = 1.47$ S/m; $\epsilon_r = 53.5$; $\rho = 1000$ kg/m³

Phantom section: Flat Section

Measurement Standard: DASY5 (IEEE/IEC/ANSI C63.19-2011)

DASY52 Configuration:

- Probe: EX3DV4 - SN7349; ConvF(8.43, 8.43, 8.43) @ 1750 MHz; Calibrated: 31.12.2018
- Sensor-Surface: 1.4mm (Mechanical Surface Detection)
- Electronics: DAE4 Sn601; Calibrated: 30.04.2019
- Phantom: Flat Phantom 5.0 (back); Type: QD 000 P50 AA; Serial: 1002
- DASY52 52.10.2(1495); SEMCAD X 14.6.12(7450)

Dipole Calibration for Body Tissue/Pin=250 mW, d=10mm/Zoom Scan (7x7x7)/Cube 0:

Measurement grid: dx=5mm, dy=5mm, dz=5mm

Reference Value = 103.1 V/m; Power Drift = -0.04 dB

Peak SAR (extrapolated) = 17.2 W/kg

SAR(1 g) = 9.35 W/kg; SAR(10 g) = 4.93 W/kg

Maximum value of SAR (measured) = 14.4 W/kg

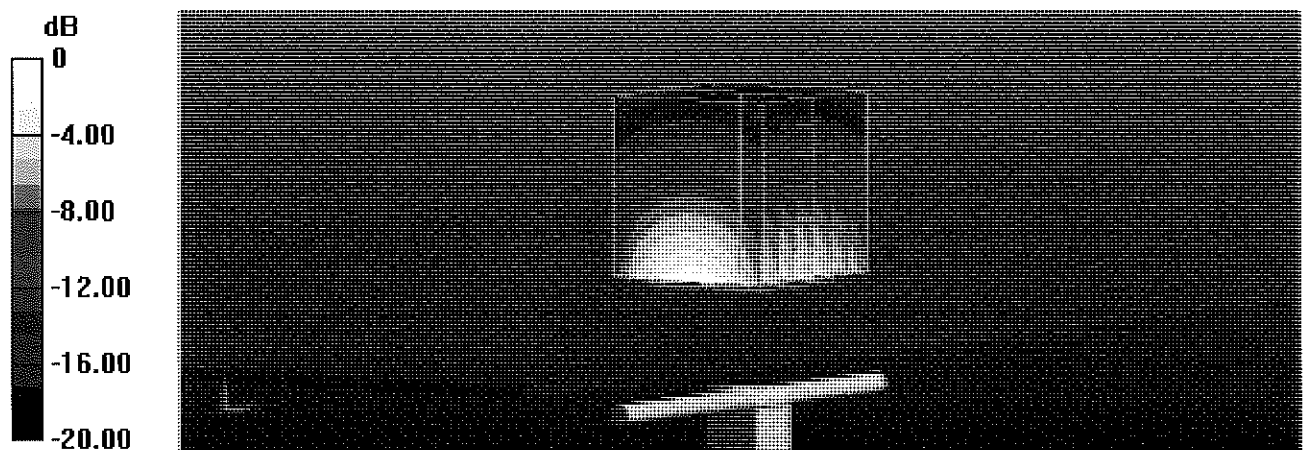

0 dB = 14.4 W/kg = 11.58 dBW/kg

Impedance Measurement Plot for Body TSL

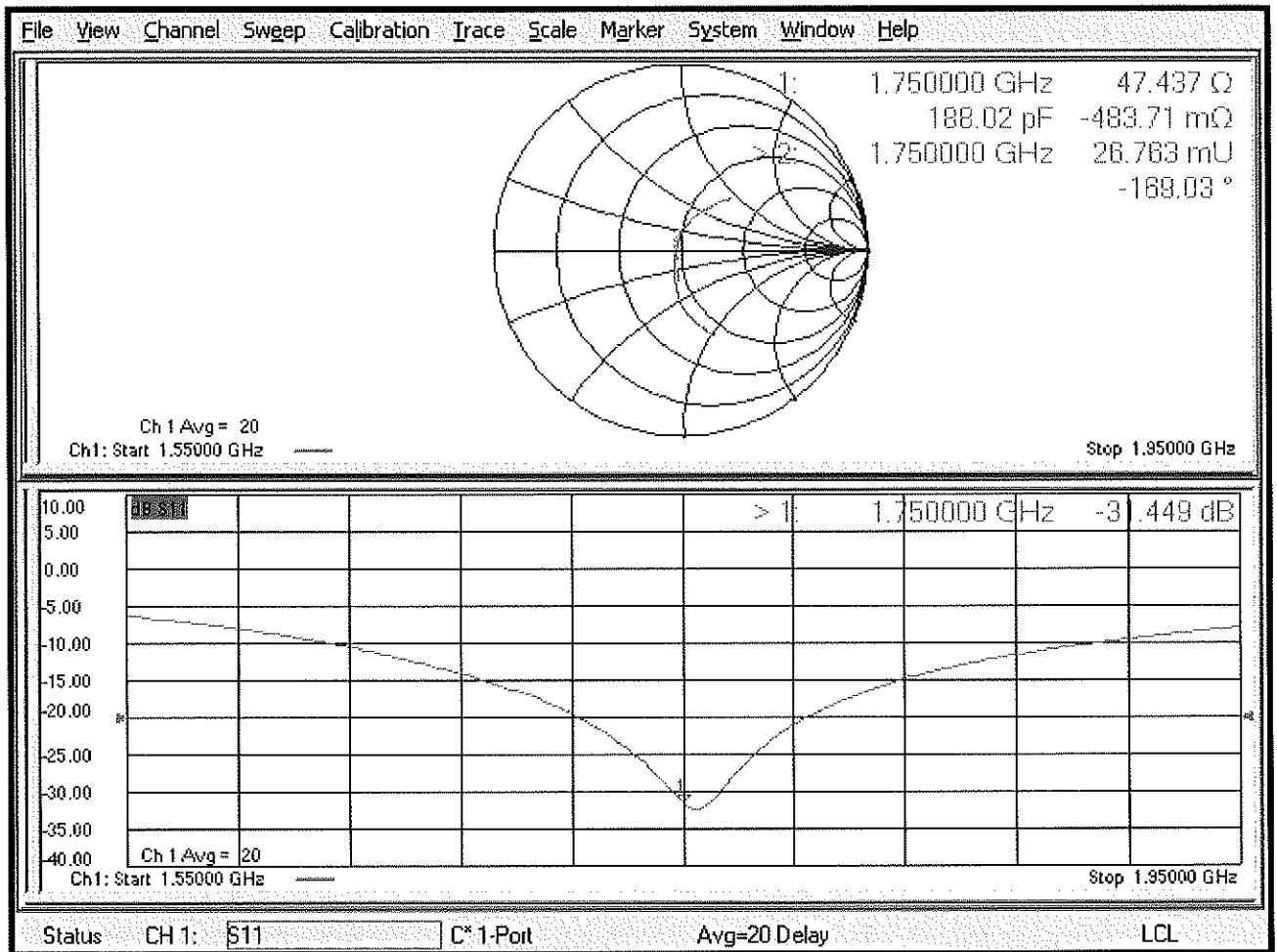

DASY5 Validation Report for SAM Head

Date: 15.05.2019

Test Laboratory: SPEAG, Zurich, Switzerland

DUT: Dipole 1750 MHz; Type: D1750V2; Serial: D1750V2 - SN:1148

Communication System: UID 0 - CW; Frequency: 1750 MHz

Medium parameters used: $f = 1750$ MHz; $\sigma = 1.37$ S/m; $\epsilon_r = 42.1$; $\rho = 1000$ kg/m³

Measurement Standard: DASY5 (IEEE/IEC/ANSI C63.19-2011)

DASY52 Configuration:

- Probe: EX3DV4 - SN7349; ConvF(8.59, 8.59, 8.59) @ 1750 MHz; Calibrated: 31.12.2018
- Sensor-Surface: 1.4mm (Mechanical Surface Detection)
- Electronics: DAE4 Sn601; Calibrated: 30.04.2019
- Phantom: SAM Head
- DASY52 52.10.2(1495); SEMCAD X 14.6.12(7450)

SAM Head/Top/Zoom Scan (7x7x7)/Cube 0: Measurement grid: dx=5mm, dy=5mm, dz=5mm

Reference Value = 107.2 V/m; Power Drift = 0.01 dB

Peak SAR (extrapolated) = 16.6 W/kg

SAR(1 g) = 9.38 W/kg; SAR(10 g) = 5.04 W/kg

Maximum value of SAR (measured) = 14.2 W/kg

SAM Head/Mouth/Zoom Scan (7x7x7)/Cube 0: Measurement grid: dx=5mm, dy=5mm, dz=5mm

Reference Value = 104.7 V/m; Power Drift = 0.02 dB

Peak SAR (extrapolated) = 16.5 W/kg

SAR(1 g) = 9.34 W/kg; SAR(10 g) = 5.04 W/kg

Maximum value of SAR (measured) = 13.9 W/kg

SAM Head/Neck/Zoom Scan (7x7x7)/Cube 0: Measurement grid: dx=5mm, dy=5mm, dz=5mm

Reference Value = 103.3 V/m; Power Drift = 0.01 dB

Peak SAR (extrapolated) = 15.5 W/kg

SAR(1 g) = 9.06 W/kg; SAR(10 g) = 4.95 W/kg

Maximum value of SAR (measured) = 13.1 W/kg

SAM Head/Ear/Zoom Scan (7x7x7)/Cube 0: Measurement grid: dx=5mm, dy=5mm, dz=5mm

Reference Value = 90.82 V/m; Power Drift = 0.02 dB

Peak SAR (extrapolated) = 12.0 W/kg

SAR(1 g) = 7.11 W/kg; SAR(10 g) = 3.98 W/kg

Maximum value of SAR (measured) = 10.2 W/kg

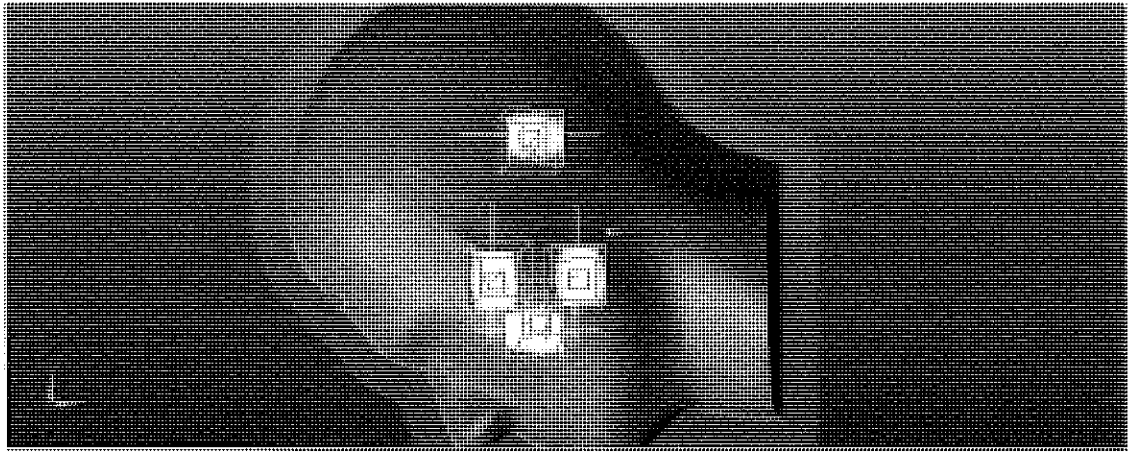
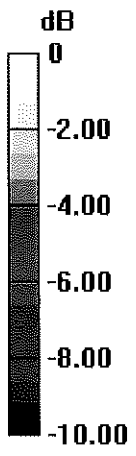

0 dB = 10.2 W/kg = 10.09 dBW/kg



Accredited by the Swiss Accreditation Service (SAS)
The Swiss Accreditation Service is one of the signatories to the EA
Multilateral Agreement for the recognition of calibration certificates

Accreditation No.: **SCS 0108**

Client **PC Test**

Certificate No: **D1900V2-5d080_Oct18**

CALIBRATION CERTIFICATE

Object **D1900V2 - SN:5d080**

Calibration procedure(s) **QA CAL-05.v10
Calibration procedure for dipole validation kits above 700 MHz**

Calibration date: **October 23, 2018**

*BN ✓
10-30-2018*

This calibration certificate documents the traceability to national standards, which realize the physical units of measurements (SI).
The measurements and the uncertainties with confidence probability are given on the following pages and are part of the certificate.

All calibrations have been conducted in the closed laboratory facility: environment temperature (22 ± 3)°C and humidity < 70%.

Calibration Equipment used (M&TE critical for calibration)

Primary Standards	ID #	Cal Date (Certificate No.)	Scheduled Calibration
Power meter NRP	SN: 104778	04-Apr-18 (No. 217-02672/02673)	Apr-19
Power sensor NRP-Z91	SN: 103244	04-Apr-18 (No. 217-02672)	Apr-19
Power sensor NRP-Z91	SN: 103245	04-Apr-18 (No. 217-02673)	Apr-19
Reference 20 dB Attenuator	SN: 5058 (20k)	04-Apr-18 (No. 217-02682)	Apr-19
Type-N mismatch combination	SN: 5047.2 / 06327	04-Apr-18 (No. 217-02683)	Apr-19
Reference Probe EX3DV4	SN: 7349	30-Dec-17 (No. EX3-7349_Dec17)	Dec-18
DAE4	SN: 601	04-Oct-18 (No. DAE4-601_Oct18)	Oct-19
Secondary Standards	ID #	Check Date (in house)	Scheduled Check
Power meter EPM-442A	SN: GB37480704	07-Oct-15 (in house check Oct-18)	In house check: Oct-20
Power sensor HP 8481A	SN: US37292783	07-Oct-15 (in house check Oct-18)	In house check: Oct-20
Power sensor HP 8481A	SN: MY41092317	07-Oct-15 (in house check Oct-18)	In house check: Oct-20
RF generator R&S SMT-06	SN: 100972	15-Jun-15 (in house check Oct-18)	In house check: Oct-20
Network Analyzer Agilent E8358A	SN: US41080477	31-Mar-14 (in house check Oct-18)	In house check: Oct-19

Calibrated by:	Jeton Kastrati	Function Laboratory Technician	Signature
Approved by:	Katja Pokovic	Technical Manager	

Issued: October 23, 2018

This calibration certificate shall not be reproduced except in full without written approval of the laboratory.



Accredited by the Swiss Accreditation Service (SAS)
The Swiss Accreditation Service is one of the signatories to the EA
Multilateral Agreement for the recognition of calibration certificates

Accreditation No.: **SCS 0108**

Glossary:

TSL	tissue simulating liquid
ConvF	sensitivity in TSL / NORM x,y,z
N/A	not applicable or not measured

Calibration is Performed According to the Following Standards:

- IEEE Std 1528-2013, "IEEE Recommended Practice for Determining the Peak Spatial-Averaged Specific Absorption Rate (SAR) in the Human Head from Wireless Communications Devices: Measurement Techniques", June 2013
- IEC 62209-1, "Measurement procedure for the assessment of Specific Absorption Rate (SAR) from hand-held and body-mounted devices used next to the ear (frequency range of 300 MHz to 6 GHz)", July 2016
- IEC 62209-2, "Procedure to determine the Specific Absorption Rate (SAR) for wireless communication devices used in close proximity to the human body (frequency range of 30 MHz to 6 GHz)", March 2010
- KDB 865664, "SAR Measurement Requirements for 100 MHz to 6 GHz"

Additional Documentation:

- DASY4/5 System Handbook

Methods Applied and Interpretation of Parameters:

- Measurement Conditions:** Further details are available from the Validation Report at the end of the certificate. All figures stated in the certificate are valid at the frequency indicated.
- Antenna Parameters with TSL:** The dipole is mounted with the spacer to position its feed point exactly below the center marking of the flat phantom section, with the arms oriented parallel to the body axis.
- Feed Point Impedance and Return Loss:** These parameters are measured with the dipole positioned under the liquid filled phantom. The impedance stated is transformed from the measurement at the SMA connector to the feed point. The Return Loss ensures low reflected power. No uncertainty required.
- Electrical Delay:** One-way delay between the SMA connector and the antenna feed point. No uncertainty required.
- SAR measured:** SAR measured at the stated antenna input power.
- SAR normalized:** SAR as measured, normalized to an input power of 1 W at the antenna connector.
- SAR for nominal TSL parameters:** The measured TSL parameters are used to calculate the nominal SAR result.

The reported uncertainty of measurement is stated as the standard uncertainty of measurement multiplied by the coverage factor $k=2$, which for a normal distribution corresponds to a coverage probability of approximately 95%.

Measurement Conditions

DASY system configuration, as far as not given on page 1.

DASY Version	DASY5	V52.10.2
Extrapolation	Advanced Extrapolation	
Phantom	Modular Flat Phantom	
Distance Dipole Center - TSL	10 mm	with Spacer
Zoom Scan Resolution	dx, dy, dz = 5 mm	
Frequency	1900 MHz \pm 1 MHz	

Head TSL parameters

The following parameters and calculations were applied.

	Temperature	Permittivity	Conductivity
Nominal Head TSL parameters	22.0 °C	40.0	1.40 mho/m
Measured Head TSL parameters	(22.0 \pm 0.2) °C	40.3 \pm 6 %	1.40 mho/m \pm 6 %
Head TSL temperature change during test	< 0.5 °C	----	----

SAR result with Head TSL

SAR averaged over 1 cm³ (1 g) of Head TSL	Condition	
SAR measured	250 mW input power	9.93 W/kg
SAR for nominal Head TSL parameters	normalized to 1W	39.8 W/kg \pm 17.0 % (k=2)

SAR averaged over 10 cm³ (10 g) of Head TSL	condition	
SAR measured	250 mW input power	5.18 W/kg
SAR for nominal Head TSL parameters	normalized to 1W	20.7 W/kg \pm 16.5 % (k=2)

Body TSL parameters

The following parameters and calculations were applied.

	Temperature	Permittivity	Conductivity
Nominal Body TSL parameters	22.0 °C	53.3	1.52 mho/m
Measured Body TSL parameters	(22.0 \pm 0.2) °C	52.9 \pm 6 %	1.47 mho/m \pm 6 %
Body TSL temperature change during test	< 0.5 °C	----	----

SAR result with Body TSL

SAR averaged over 1 cm³ (1 g) of Body TSL	Condition	
SAR measured	250 mW input power	9.62 W/kg
SAR for nominal Body TSL parameters	normalized to 1W	39.2 W/kg \pm 17.0 % (k=2)

SAR averaged over 10 cm³ (10 g) of Body TSL	condition	
SAR measured	250 mW input power	5.09 W/kg
SAR for nominal Body TSL parameters	normalized to 1W	20.6 W/kg \pm 16.5 % (k=2)

Appendix (Additional assessments outside the scope of SCS 0108)

Antenna Parameters with Head TSL

Impedance, transformed to feed point	$52.5 \Omega + 7.9 j\Omega$
Return Loss	- 21.8 dB

Antenna Parameters with Body TSL

Impedance, transformed to feed point	$48.1 \Omega + 8.1 j\Omega$
Return Loss	- 21.5 dB

General Antenna Parameters and Design

Electrical Delay (one direction)	1.193 ns
----------------------------------	----------

After long term use with 100W radiated power, only a slight warming of the dipole near the feedpoint can be measured.

The dipole is made of standard semirigid coaxial cable. The center conductor of the feeding line is directly connected to the second arm of the dipole. The antenna is therefore short-circuited for DC-signals. On some of the dipoles, small end caps are added to the dipole arms in order to improve matching when loaded according to the position as explained in the "Measurement Conditions" paragraph. The SAR data are not affected by this change. The overall dipole length is still according to the Standard.

No excessive force must be applied to the dipole arms, because they might bend or the soldered connections near the feedpoint may be damaged.

Additional EUT Data

Manufactured by	SPEAG
Manufactured on	June 28, 2006

DASY5 Validation Report for Head TSL

Date: 23.10.2018

Test Laboratory: SPEAG, Zurich, Switzerland

DUT: Dipole 1900 MHz; Type: D1900V2; Serial: D1900V2 - SN:5d080

Communication System: UID 0 - CW; Frequency: 1900 MHz

Medium parameters used: $f = 1900$ MHz; $\sigma = 1.4$ S/m; $\epsilon_r = 40.3$; $\rho = 1000$ kg/m³

Phantom section: Flat Section

Measurement Standard: DASY5 (IEEE/IEC/ANSI C63.19-2011)

DASY52 Configuration:

- Probe: EX3DV4 - SN7349; ConvF(8.18, 8.18, 8.18) @ 1900 MHz; Calibrated: 30.12.2017
- Sensor-Surface: 1.4mm (Mechanical Surface Detection)
- Electronics: DAE4 Sn601; Calibrated: 04.10.2018
- Phantom: Flat Phantom 5.0 (front); Type: QD 000 P50 AA; Serial: 1001
- DASY52 52.10.2(1495); SEMCAD X 14.6.12(7450)

Dipole Calibration for Head Tissue/Pin=250 mW, d=10mm/Zoom Scan (7x7x7)/Cube 0:

Measurement grid: dx=5mm, dy=5mm, dz=5mm

Reference Value = 110.0 V/m; Power Drift = -0.05 dB

Peak SAR (extrapolated) = 18.7 W/kg

SAR(1 g) = 9.93 W/kg; SAR(10 g) = 5.18 W/kg

Maximum value of SAR (measured) = 15.6 W/kg

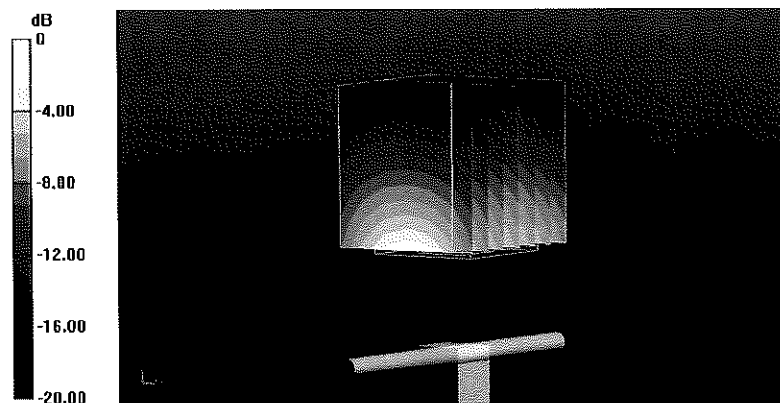

0 dB = 15.6 W/kg = 11.93 dBW/kg

Impedance Measurement Plot for Head TSL

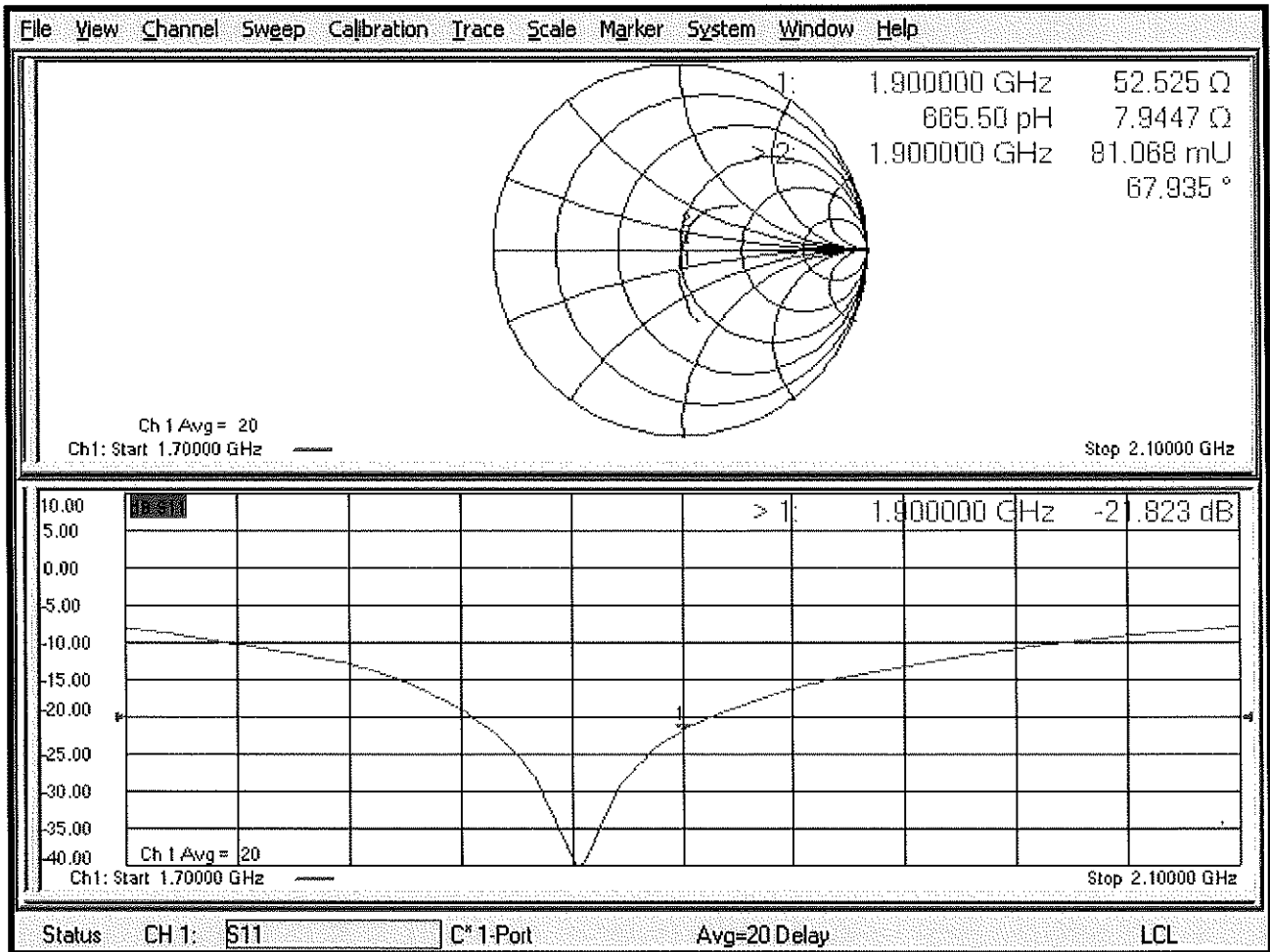

DASY5 Validation Report for Body TSL

Date: 23.10.2018

Test Laboratory: SPEAG, Zurich, Switzerland

DUT: Dipole 1900 MHz; Type: D1900V2; Serial: D1900V2 - SN:5d080

Communication System: UID 0 - CW; Frequency: 1900 MHz

Medium parameters used: $f = 1900$ MHz; $\sigma = 1.47$ S/m; $\epsilon_r = 52.9$; $\rho = 1000$ kg/m³

Phantom section: Flat Section

Measurement Standard: DASY5 (IEEE/IEC/ANSI C63.19-2011)

DASY52 Configuration:

- Probe: EX3DV4 - SN7349; ConvF(8.15, 8.15, 8.15) @ 1900 MHz; Calibrated: 30.12.2017
- Sensor-Surface: 1.4mm (Mechanical Surface Detection)
- Electronics: DAE4 Sn601; Calibrated: 04.10.2018
- Phantom: Flat Phantom 5.0 (back); Type: QD 000 P50 AA; Serial: 1002
- DASY52 52.10.2(1495); SEMCAD X 14.6.12(7450)

Dipole Calibration for Body Tissue/Pin=250 mW, d=10mm/Zoom Scan (7x7x7)/Cube 0:

Measurement grid: dx=5mm, dy=5mm, dz=5mm

Reference Value = 99.86 V/m; Power Drift = 0.00 dB

Peak SAR (extrapolated) = 17.3 W/kg

SAR(1 g) = 9.62 W/kg; SAR(10 g) = 5.09 W/kg

Maximum value of SAR (measured) = 14.1 W/kg

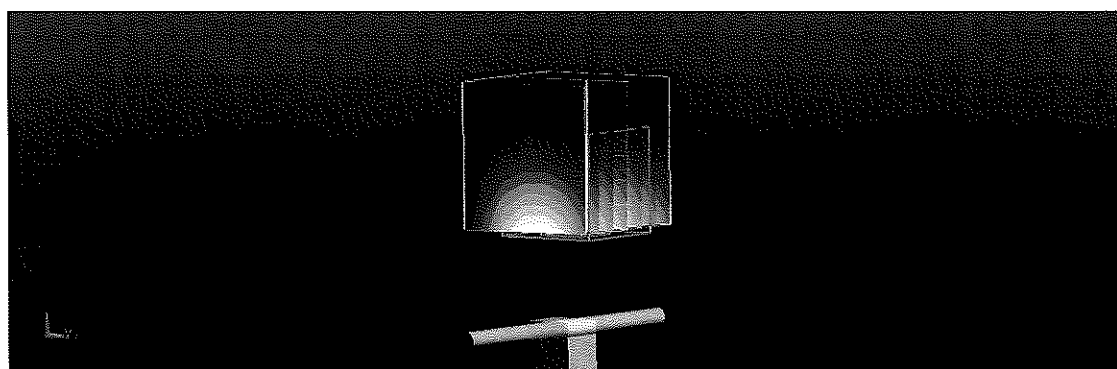
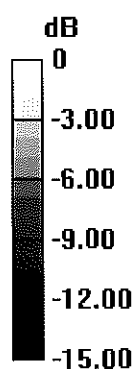

0 dB = 14.1 W/kg = 11.49 dBW/kg

Impedance Measurement Plot for Body TSL

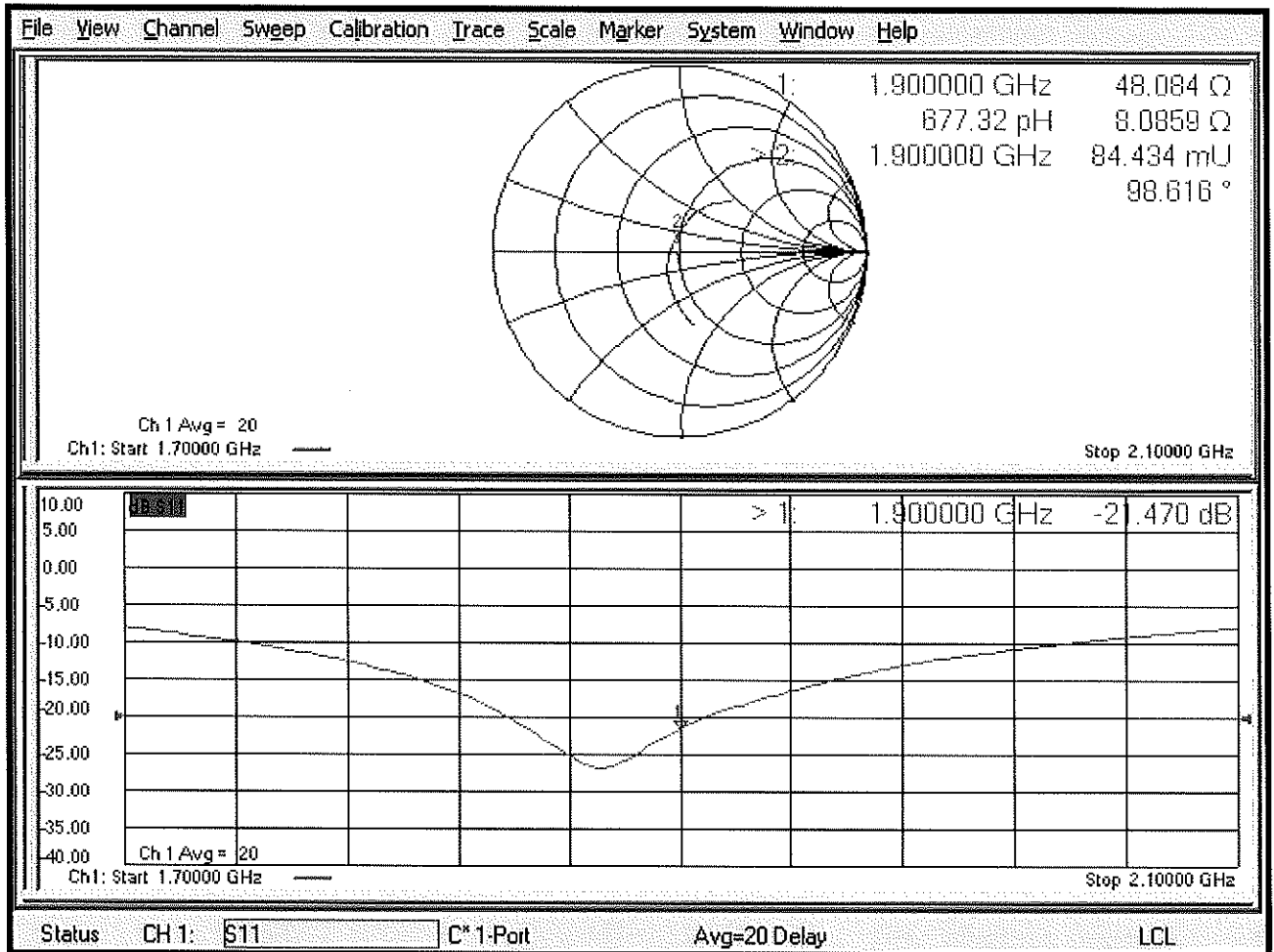



Accredited by the Swiss Accreditation Service (SAS)
The Swiss Accreditation Service is one of the signatories to the EA
Multilateral Agreement for the recognition of calibration certificates

Accreditation No.: **SCS 0108**

Client **PC Test**

Certificate No: **D1900V2-5d148_Feb19**

CALIBRATION CERTIFICATE

Object **D1900V2 - SN:5d148**

Calibration procedure(s) **QA CAL-05.v11
Calibration Procedure for SAR Validation Sources between 0.7-3 GHz**

Calibration date: **February 21, 2019**

*BNV
03-01-19*

This calibration certificate documents the traceability to national standards, which realize the physical units of measurements (SI).
The measurements and the uncertainties with confidence probability are given on the following pages and are part of the certificate.

All calibrations have been conducted in the closed laboratory facility: environment temperature (22 ± 3)°C and humidity < 70%.

Calibration Equipment used (M&TE critical for calibration)

Primary Standards	ID #	Cal Date (Certificate No.)	Scheduled Calibration
Power meter NRP	SN: 104778	04-Apr-18 (No. 217-02672/02673)	Apr-19
Power sensor NRP-Z91	SN: 103244	04-Apr-18 (No. 217-02672)	Apr-19
Power sensor NRP-Z91	SN: 103245	04-Apr-18 (No. 217-02673)	Apr-19
Reference 20 dB Attenuator	SN: 5058 (20k)	04-Apr-18 (No. 217-02682)	Apr-19
Type-N mismatch combination	SN: 5047.2 / 06327	04-Apr-18 (No. 217-02683)	Apr-19
Reference Probe EX3DV4	SN: 7349	31-Dec-18 (No. EX3-7349_Dec18)	Dec-19
DAE4	SN: 601	04-Oct-18 (No. DAE4-601_Oct18)	Oct-19

Secondary Standards	ID #	Check Date (in house)	Scheduled Check
Power meter E4419B	SN: GB39512475	07-Oct-15 (in house check Feb-19)	In house check: Oct-20
Power sensor HP 8481A	SN: US37292783	07-Oct-15 (in house check Oct-18)	In house check: Oct-20
Power sensor HP 8481A	SN: MY41092317	07-Oct-15 (in house check Oct-18)	In house check: Oct-20
RF generator R&S SMT-06	SN: 100972	15-Jun-15 (in house check Oct-18)	In house check: Oct-20
Network Analyzer Agilent E8358A	SN: US41080477	31-Mar-14 (in house check Oct-18)	In house check: Oct-19

Calibrated by: **Manu Seitz** Name: **Manu Seitz** Function: **Laboratory Technician** Signature:

Approved by: **Katja Pokovic** Name: **Katja Pokovic** Technical Manager Signature:

Issued: February 21, 2019

This calibration certificate shall not be reproduced except in full without written approval of the laboratory.



Accredited by the Swiss Accreditation Service (SAS)
The Swiss Accreditation Service is one of the signatories to the EA
Multilateral Agreement for the recognition of calibration certificates

Accreditation No.: **SCS 0108**

Glossary:

TSL	tissue simulating liquid
ConvF	sensitivity in TSL / NORM x,y,z
N/A	not applicable or not measured

Calibration is Performed According to the Following Standards:

- a) IEEE Std 1528-2013, "IEEE Recommended Practice for Determining the Peak Spatial-Averaged Specific Absorption Rate (SAR) in the Human Head from Wireless Communications Devices: Measurement Techniques", June 2013
- b) IEC 62209-1, "Measurement procedure for the assessment of Specific Absorption Rate (SAR) from hand-held and body-mounted devices used next to the ear (frequency range of 300 MHz to 6 GHz)", July 2016
- c) IEC 62209-2, "Procedure to determine the Specific Absorption Rate (SAR) for wireless communication devices used in close proximity to the human body (frequency range of 30 MHz to 6 GHz)", March 2010
- d) KDB 865664, "SAR Measurement Requirements for 100 MHz to 6 GHz"

Additional Documentation:

- e) DASY4/5 System Handbook

Methods Applied and Interpretation of Parameters:

- *Measurement Conditions:* Further details are available from the Validation Report at the end of the certificate. All figures stated in the certificate are valid at the frequency indicated.
- *Antenna Parameters with TSL:* The dipole is mounted with the spacer to position its feed point exactly below the center marking of the flat phantom section, with the arms oriented parallel to the body axis.
- *Feed Point Impedance and Return Loss:* These parameters are measured with the dipole positioned under the liquid filled phantom. The impedance stated is transformed from the measurement at the SMA connector to the feed point. The Return Loss ensures low reflected power. No uncertainty required.
- *Electrical Delay:* One-way delay between the SMA connector and the antenna feed point. No uncertainty required.
- *SAR measured:* SAR measured at the stated antenna input power.
- *SAR normalized:* SAR as measured, normalized to an input power of 1 W at the antenna connector.
- *SAR for nominal TSL parameters:* The measured TSL parameters are used to calculate the nominal SAR result.

The reported uncertainty of measurement is stated as the standard uncertainty of measurement multiplied by the coverage factor $k=2$, which for a normal distribution corresponds to a coverage probability of approximately 95%.

Measurement Conditions

DASY system configuration, as far as not given on page 1.

DASY Version	DASY5	V52.10.2
Extrapolation	Advanced Extrapolation	
Phantom	Modular Flat Phantom	
Distance Dipole Center - TSL	10 mm	with Spacer
Zoom Scan Resolution	dx, dy, dz = 5 mm	
Frequency	1900 MHz \pm 1 MHz	

Head TSL parameters

The following parameters and calculations were applied.

	Temperature	Permittivity	Conductivity
Nominal Head TSL parameters	22.0 °C	40.0	1.40 mho/m
Measured Head TSL parameters	(22.0 \pm 0.2) °C	40.9 \pm 6 %	1.38 mho/m \pm 6 %
Head TSL temperature change during test	< 0.5 °C	----	----

SAR result with Head TSL

SAR averaged over 1 cm ³ (1 g) of Head TSL	Condition	
SAR measured	250 mW input power	9.65 W/kg
SAR for nominal Head TSL parameters	normalized to 1W	39.1 W/kg \pm 17.0 % (k=2)

SAR averaged over 10 cm ³ (10 g) of Head TSL	condition	
SAR measured	250 mW input power	5.05 W/kg
SAR for nominal Head TSL parameters	normalized to 1W	20.4 W/kg \pm 16.5 % (k=2)

Body TSL parameters

The following parameters and calculations were applied.

	Temperature	Permittivity	Conductivity
Nominal Body TSL parameters	22.0 °C	53.3	1.52 mho/m
Measured Body TSL parameters	(22.0 \pm 0.2) °C	53.6 \pm 6 %	1.47 mho/m \pm 6 %
Body TSL temperature change during test	< 0.5 °C	----	----

SAR result with Body TSL

SAR averaged over 1 cm ³ (1 g) of Body TSL	Condition	
SAR measured	250 mW input power	9.56 W/kg
SAR for nominal Body TSL parameters	normalized to 1W	39.1 W/kg \pm 17.0 % (k=2)

SAR averaged over 10 cm ³ (10 g) of Body TSL	condition	
SAR measured	250 mW input power	5.05 W/kg
SAR for nominal Body TSL parameters	normalized to 1W	20.5 W/kg \pm 16.5 % (k=2)

Appendix (Additional assessments outside the scope of SCS 0108)

Antenna Parameters with Head TSL

Impedance, transformed to feed point	$51.8 \Omega + 6.8 j\Omega$
Return Loss	- 23.2 dB

Antenna Parameters with Body TSL

Impedance, transformed to feed point	$48.4 \Omega + 7.8 j\Omega$
Return Loss	- 21.9 dB

General Antenna Parameters and Design

Electrical Delay (one direction)	1.170 ns
----------------------------------	----------

After long term use with 100W radiated power, only a slight warming of the dipole near the feedpoint can be measured.

The dipole is made of standard semirigid coaxial cable. The center conductor of the feeding line is directly connected to the second arm of the dipole. The antenna is therefore short-circuited for DC-signals. On some of the dipoles, small end caps are added to the dipole arms in order to improve matching when loaded according to the position as explained in the "Measurement Conditions" paragraph. The SAR data are not affected by this change. The overall dipole length is still according to the Standard.

No excessive force must be applied to the dipole arms, because they might bend or the soldered connections near the feedpoint may be damaged.

Additional EUT Data

Manufactured by	SPEAG
-----------------	-------

DASY5 Validation Report for Head TSL

Date: 21.02.2019

Test Laboratory: SPEAG, Zurich, Switzerland

DUT: Dipole 1900 MHz; Type: D1900V2; Serial: D1900V2 - SN:5d148

Communication System: UID 0 - CW; Frequency: 1900 MHz

Medium parameters used: $f = 1900$ MHz; $\sigma = 1.38$ S/m; $\epsilon_r = 40.9$; $\rho = 1000$ kg/m³

Phantom section: Flat Section

Measurement Standard: DASY5 (IEEE/IEC/ANSI C63.19-2011)

DASY52 Configuration:

- Probe: EX3DV4 - SN7349; ConvF(8.26, 8.26, 8.26) @ 1900 MHz; Calibrated: 31.12.2018
- Sensor-Surface: 1.4mm (Mechanical Surface Detection)
- Electronics: DAE4 Sn601; Calibrated: 04.10.2018
- Phantom: Flat Phantom 5.0 (front); Type: QD 000 P50 AA; Serial: 1001
- DASY52 52.10.2(1495); SEMCAD X 14.6.12(7450)

Dipole Calibration for Head Tissue/Pin=250 mW, d=10mm/Zoom Scan (7x7x7)/Cube 0:

Measurement grid: dx=5mm, dy=5mm, dz=5mm

Reference Value = 109.4 V/m; Power Drift = 0.01 dB

Peak SAR (extrapolated) = 17.8 W/kg

SAR(1 g) = 9.65 W/kg; SAR(10 g) = 5.05 W/kg

Maximum value of SAR (measured) = 15.0 W/kg

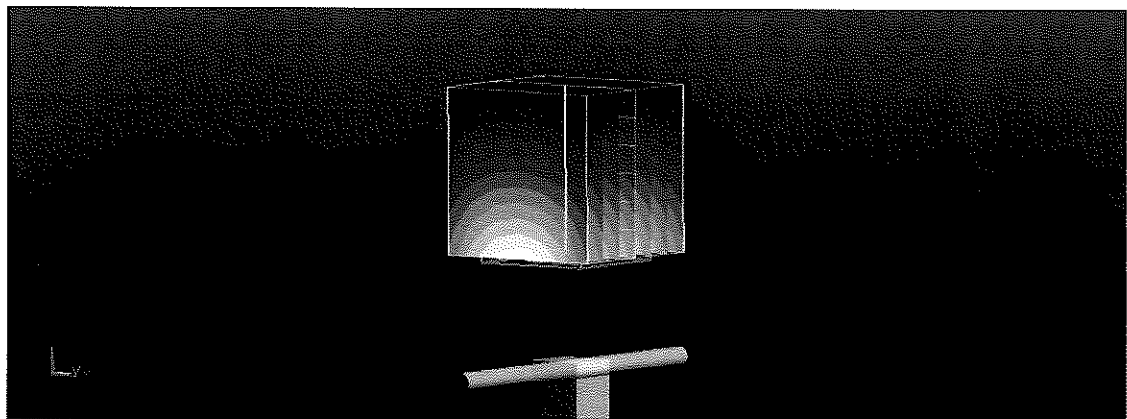
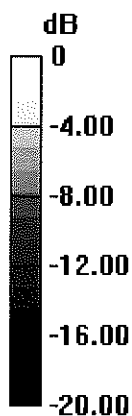

0 dB = 15.0 W/kg = 11.76 dBW/kg

Impedance Measurement Plot for Head TSL

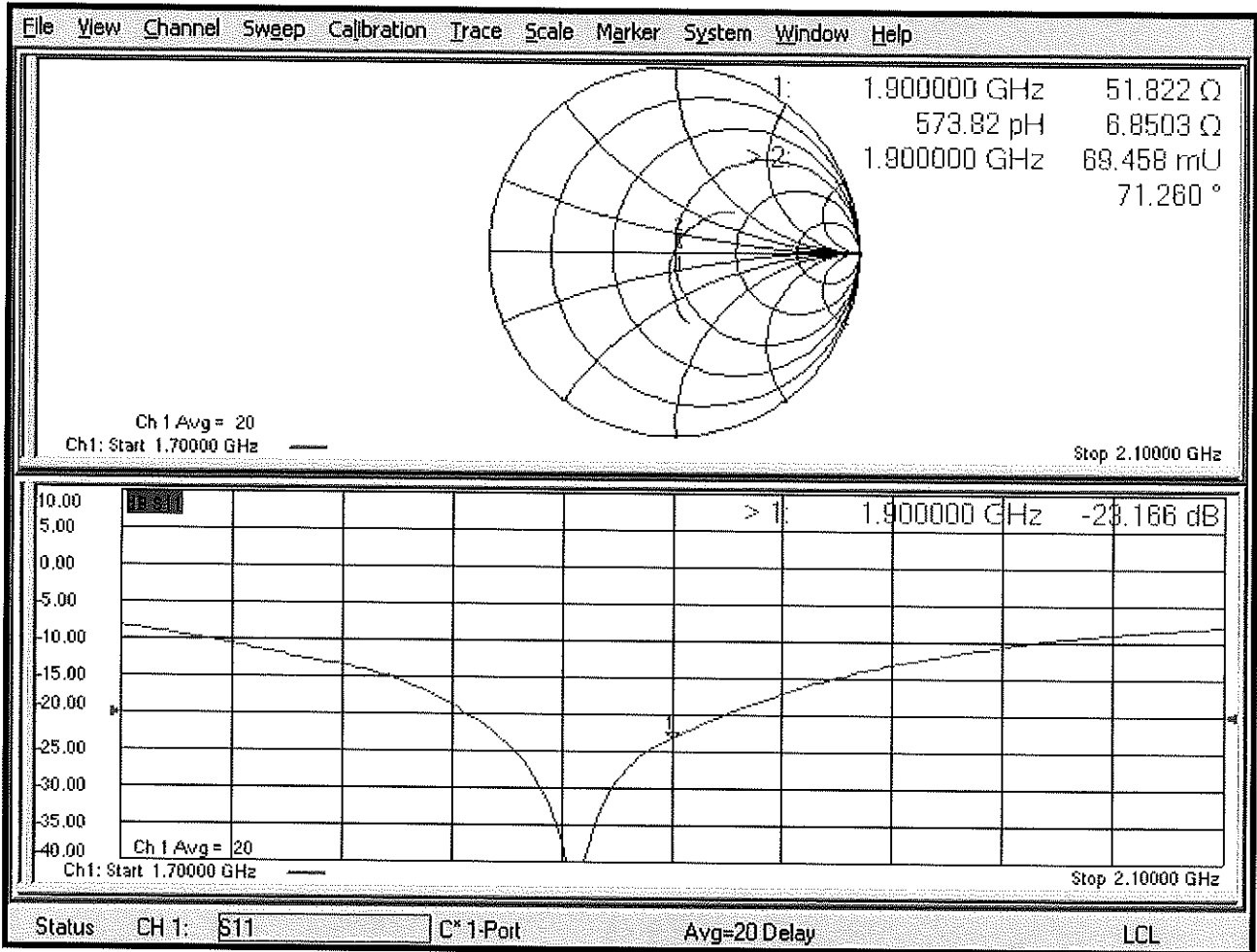

DASY5 Validation Report for Body TSL

Date: 21.02.2019

Test Laboratory: SPEAG, Zurich, Switzerland

DUT: Dipole 1900 MHz; Type: D1900V2; Serial: D1900V2 - SN:5d148

Communication System: UID 0 - CW; Frequency: 1900 MHz

Medium parameters used: $f = 1900$ MHz; $\sigma = 1.47$ S/m; $\epsilon_r = 53.6$; $\rho = 1000$ kg/m³

Phantom section: Flat Section

Measurement Standard: DASY5 (IEEE/IEC/ANSI C63.19-2011)

DASY52 Configuration:

- Probe: EX3DV4 - SN7349; ConvF(8.23, 8.23, 8.23) @ 1900 MHz; Calibrated: 31.12.2018
- Sensor-Surface: 1.4mm (Mechanical Surface Detection)
- Electronics: DAE4 Sn601; Calibrated: 04.10.2018
- Phantom: Flat Phantom 5.0 (back); Type: QD 000 P50 AA; Serial: 1002
- DASY52 52.10.2(1495); SEMCAD X 14.6.12(7450)

Dipole Calibration for Body Tissue/Pin=250 mW, d=10mm/Zoom Scan (7x7x7)/Cube 0:

Measurement grid: dx=5mm, dy=5mm, dz=5mm

Reference Value = 103.7 V/m; Power Drift = -0.03 dB

Peak SAR (extrapolated) = 17.0 W/kg

SAR(1 g) = 9.56 W/kg; SAR(10 g) = 5.05 W/kg

Maximum value of SAR (measured) = 14.4 W/kg

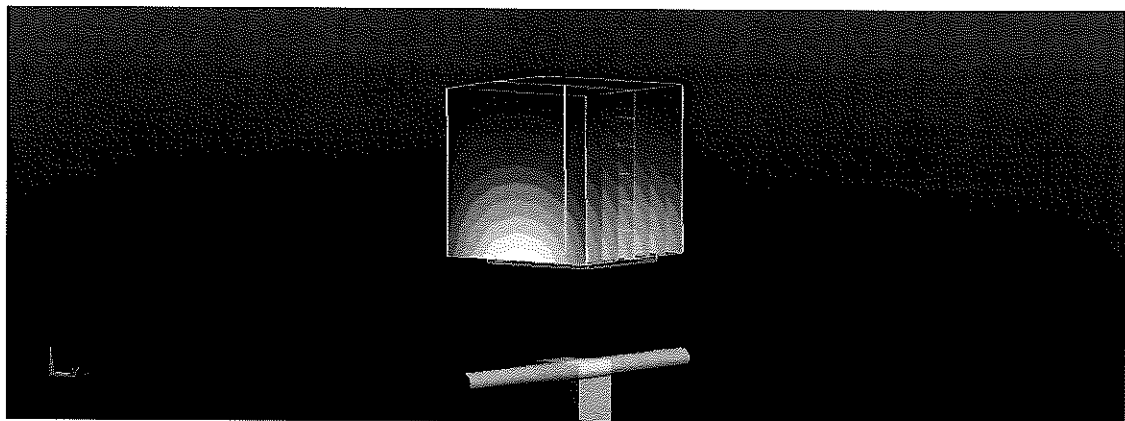
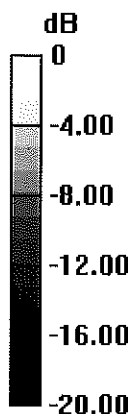

0 dB = 14.4 W/kg = 11.58 dBW/kg

Impedance Measurement Plot for Body TSL

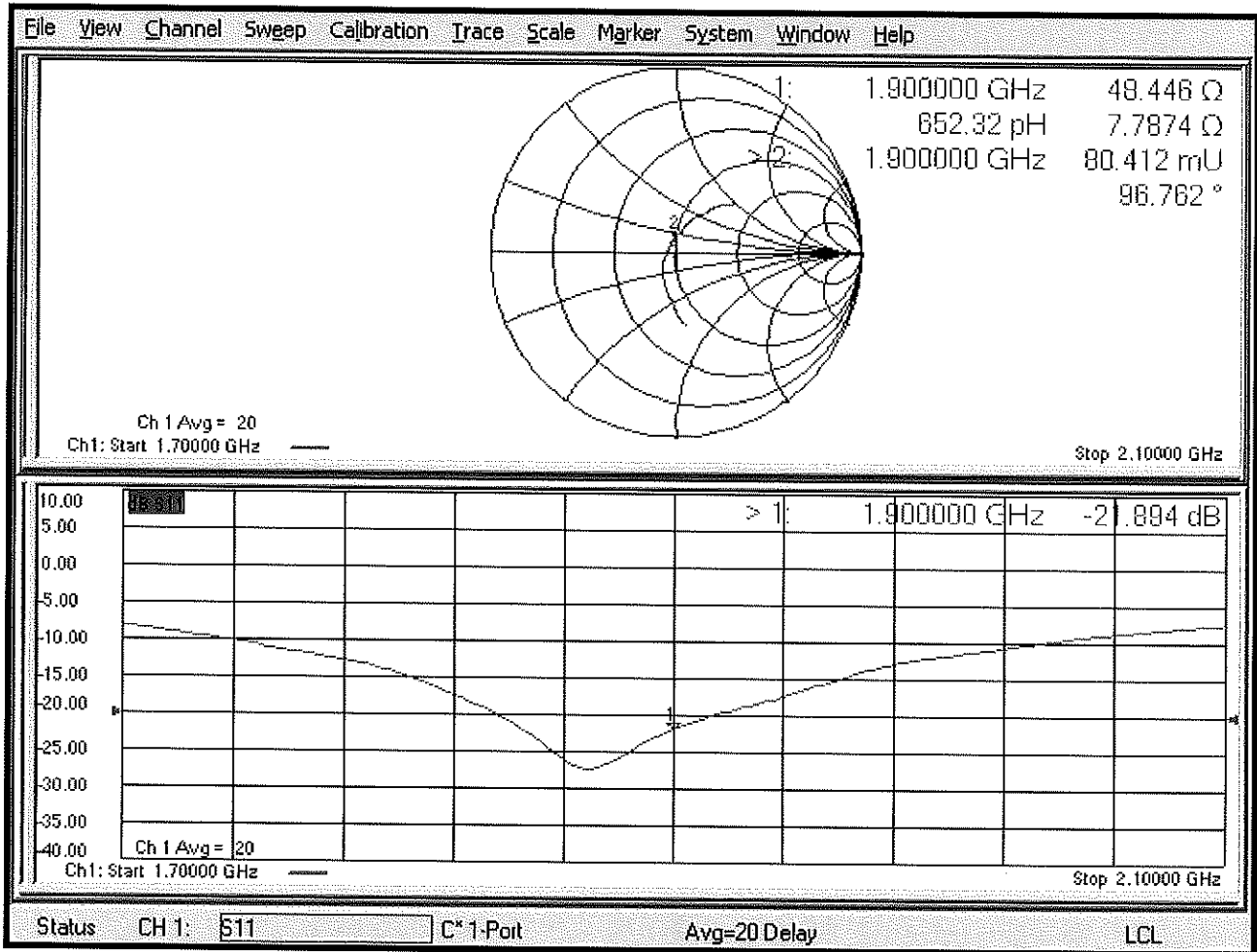

**Calibration Laboratory of
Schmid & Partner
Engineering AG**
Zeughausstrasse 43, 8004 Zurich, Switzerland



S Schweizerischer Kalibrierdienst
C Service suisse d'étalonnage
S Servizio svizzero di taratura
S Swiss Calibration Service

Accredited by the Swiss Accreditation Service (SAS)
The Swiss Accreditation Service is one of the signatories to the EA
Multilateral Agreement for the recognition of calibration certificates

Accreditation No.: **SCS 0108**

Client **PC Test**

Certificate No: **D2450V2-719_Aug17**

CALIBRATION CERTIFICATE

Object **D2450V2 - SN:719**

Calibration procedure(s) **QA CAL-05.v9
Calibration procedure for dipole validation kits above 700 MHz**

Calibration date: **August 17, 2017**

PMV
8/27/17
Extended
BN
8/19/2018

This calibration certificate documents the traceability to national standards, which realize the physical units of measurements (SI).
The measurements and the uncertainties with confidence probability are given on the following pages and are part of the certificate.

All calibrations have been conducted in the closed laboratory facility: environment temperature (22 ± 3)°C and humidity < 70%.

Calibration Equipment used (M&TE critical for calibration)

Primary Standards	ID #	Cal Date (Certificate No.)	Scheduled Calibration
Power meter NRP	SN: 104778	04-Apr-17 (No. 217-02521/02522)	Apr-18
Power sensor NRP-Z91	SN: 103244	04-Apr-17 (No. 217-02521)	Apr-18
Power sensor NRP-Z91	SN: 103245	04-Apr-17 (No. 217-02522)	Apr-18
Reference 20 dB Attenuator	SN: 5058 (20k)	07-Apr-17 (No. 217-02528)	Apr-18
Type-N mismatch combination	SN: 5047.2 / 06327	07-Apr-17 (No. 217-02529)	Apr-18
Reference Probe EX3DV4	SN: 7349	31-May-17 (No. EX3-7349_May17)	May-18
DAE4	SN: 601	28-Mar-17 (No. DAE4-601_Mar17)	Mar-18
Secondary Standards	ID #	Check Date (in house)	Scheduled Check
Power meter EPM-442A	SN: GB37480704	07-Oct-15 (in house check Oct-16)	In house check: Oct-18
Power sensor HP 8481A	SN: US37292783	07-Oct-15 (in house check Oct-16)	In house check: Oct-18
Power sensor HP 8481A	SN: MY41092317	07-Oct-15 (in house check Oct-16)	In house check: Oct-18
RF generator R&S SMT-06	SN: 100972	15-Jun-15 (in house check Oct-16)	In house check: Oct-18
Network Analyzer HP 8753E	SN: US37390585	18-Oct-01 (in house check Oct-16)	In house check: Oct-17

Calibrated by: **Michael Weber** Name **Laboratory Technician** Function *H. Weber* Signature

Approved by: **Katja Pokovic** Name **Technical Manager** Function *[Signature]* Signature

Issued: August 17, 2017

This calibration certificate shall not be reproduced except in full without written approval of the laboratory.



Accredited by the Swiss Accreditation Service (SAS)
The Swiss Accreditation Service is one of the signatories to the EA
Multilateral Agreement for the recognition of calibration certificates

Accreditation No.: **SCS 0108**

Glossary:

TSL	tissue simulating liquid
ConvF	sensitivity in TSL / NORM x,y,z
N/A	not applicable or not measured

Calibration is Performed According to the Following Standards:

- IEEE Std 1528-2013, "IEEE Recommended Practice for Determining the Peak Spatial-Averaged Specific Absorption Rate (SAR) in the Human Head from Wireless Communications Devices: Measurement Techniques", June 2013
- IEC 62209-1, "Measurement procedure for the assessment of Specific Absorption Rate (SAR) from hand-held and body-mounted devices used next to the ear (frequency range of 300 MHz to 6 GHz)", July 2016
- IEC 62209-2, "Procedure to determine the Specific Absorption Rate (SAR) for wireless communication devices used in close proximity to the human body (frequency range of 30 MHz to 6 GHz)", March 2010
- KDB 865664, "SAR Measurement Requirements for 100 MHz to 6 GHz"

Additional Documentation:

- DASY4/5 System Handbook

Methods Applied and Interpretation of Parameters:

- Measurement Conditions:** Further details are available from the Validation Report at the end of the certificate. All figures stated in the certificate are valid at the frequency indicated.
- Antenna Parameters with TSL:** The dipole is mounted with the spacer to position its feed point exactly below the center marking of the flat phantom section, with the arms oriented parallel to the body axis.
- Feed Point Impedance and Return Loss:** These parameters are measured with the dipole positioned under the liquid filled phantom. The impedance stated is transformed from the measurement at the SMA connector to the feed point. The Return Loss ensures low reflected power. No uncertainty required.
- Electrical Delay:** One-way delay between the SMA connector and the antenna feed point. No uncertainty required.
- SAR measured:** SAR measured at the stated antenna input power.
- SAR normalized:** SAR as measured, normalized to an input power of 1 W at the antenna connector.
- SAR for nominal TSL parameters:** The measured TSL parameters are used to calculate the nominal SAR result.

The reported uncertainty of measurement is stated as the standard uncertainty of measurement multiplied by the coverage factor $k=2$, which for a normal distribution corresponds to a coverage probability of approximately 95%.

Measurement Conditions

DASY system configuration, as far as not given on page 1.

DASY Version	DASY5	V52.10.0
Extrapolation	Advanced Extrapolation	
Phantom	Modular Flat Phantom	
Distance Dipole Center - TSL	10 mm	with Spacer
Zoom Scan Resolution	dx, dy, dz = 5 mm	
Frequency	2450 MHz ± 1 MHz	

Head TSL parameters

The following parameters and calculations were applied.

	Temperature	Permittivity	Conductivity
Nominal Head TSL parameters	22.0 °C	39.2	1.80 mho/m
Measured Head TSL parameters	(22.0 ± 0.2) °C	37.8 ± 6 %	1.86 mho/m ± 6 %
Head TSL temperature change during test	< 0.5 °C	----	----

SAR result with Head TSL

SAR averaged over 1 cm³ (1 g) of Head TSL	Condition	
SAR measured	250 mW input power	13.3 W/kg
SAR for nominal Head TSL parameters	normalized to 1W	51.9 W/kg ± 17.0 % (k=2)

SAR averaged over 10 cm³ (10 g) of Head TSL	condition	
SAR measured	250 mW input power	6.15 W/kg
SAR for nominal Head TSL parameters	normalized to 1W	24.3 W/kg ± 16.5 % (k=2)

Body TSL parameters

The following parameters and calculations were applied.

	Temperature	Permittivity	Conductivity
Nominal Body TSL parameters	22.0 °C	52.7	1.95 mho/m
Measured Body TSL parameters	(22.0 ± 0.2) °C	51.9 ± 6 %	2.03 mho/m ± 6 %
Body TSL temperature change during test	< 0.5 °C	----	----

SAR result with Body TSL

SAR averaged over 1 cm³ (1 g) of Body TSL	Condition	
SAR measured	250 mW input power	12.8 W/kg
SAR for nominal Body TSL parameters	normalized to 1W	50.1 W/kg ± 17.0 % (k=2)

SAR averaged over 10 cm³ (10 g) of Body TSL	condition	
SAR measured	250 mW input power	6.00 W/kg
SAR for nominal Body TSL parameters	normalized to 1W	23.7 W/kg ± 16.5 % (k=2)

Appendix (Additional assessments outside the scope of SCS 0108)

Antenna Parameters with Head TSL

Impedance, transformed to feed point	55.7 Ω + 7.0 j Ω
Return Loss	- 21.4 dB

Antenna Parameters with Body TSL

Impedance, transformed to feed point	51.4 Ω + 8.1 j Ω
Return Loss	- 21.8 dB

General Antenna Parameters and Design

Electrical Delay (one direction)	1.150 ns
----------------------------------	----------

After long term use with 100W radiated power, only a slight warming of the dipole near the feedpoint can be measured.

The dipole is made of standard semirigid coaxial cable. The center conductor of the feeding line is directly connected to the second arm of the dipole. The antenna is therefore short-circuited for DC-signals. On some of the dipoles, small end caps are added to the dipole arms in order to improve matching when loaded according to the position as explained in the "Measurement Conditions" paragraph. The SAR data are not affected by this change. The overall dipole length is still according to the Standard.

No excessive force must be applied to the dipole arms, because they might bend or the soldered connections near the feedpoint may be damaged.

Additional EUT Data

Manufactured by	SPEAG
Manufactured on	September 10, 2002

DASY5 Validation Report for Head TSL

Date: 17.08.2017

Test Laboratory: SPEAG, Zurich, Switzerland

DUT: Dipole 2450 MHz; Type: D2450V2; Serial: D2450V2 - SN: 719

Communication System: UID 0 - CW; Frequency: 2450 MHz

Medium parameters used: $f = 2450$ MHz; $\sigma = 1.86$ S/m; $\epsilon_r = 37.8$; $\rho = 1000$ kg/m³

Phantom section: Flat Section

Measurement Standard: DASY5 (IEEE/IEC/ANSI C63.19-2011)

DASY52 Configuration:

- Probe: EX3DV4 - SN7349; ConvF(8.12, 8.12, 8.12); Calibrated: 31.05.2017;
- Sensor-Surface: 1.4mm (Mechanical Surface Detection)
- Electronics: DAE4 Sn601; Calibrated: 28.03.2017
- Phantom: Flat Phantom 5.0 (front); Type: QD 000 P50 AA; Serial: 1001
- DASY52 52.10.0(1446); SEMCAD X 14.6.10(7417)

Dipole Calibration for Head Tissue/Pin=250 mW, d=10mm/Zoom Scan (7x7x7)/Cube 0:

Measurement grid: dx=5mm, dy=5mm, dz=5mm

Reference Value = 112.8 V/m; Power Drift = -0.01 dB

Peak SAR (extrapolated) = 26.9 W/kg

SAR(1 g) = 13.3 W/kg; SAR(10 g) = 6.15 W/kg

Maximum value of SAR (measured) = 21.6 W/kg

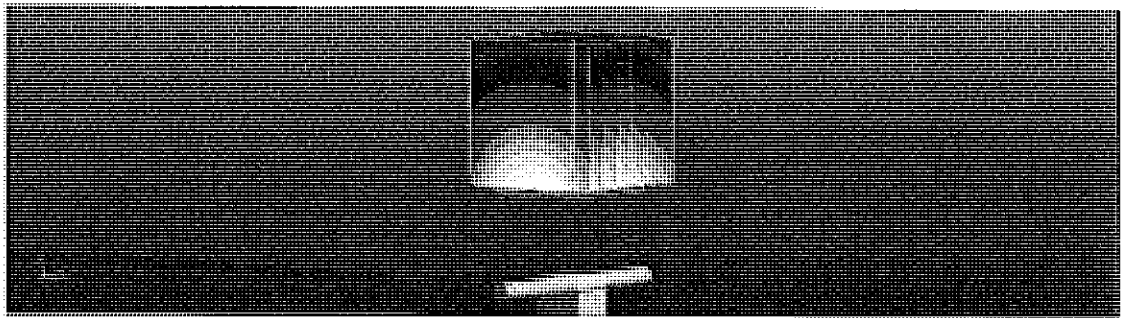
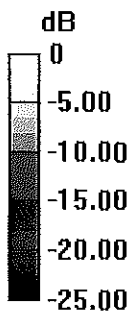

0 dB = 21.6 W/kg = 13.34 dBW/kg

Impedance Measurement Plot for Head TSL

17 Aug 2017 12:38:03
CH1 S11 1 U FS 1: 55.682 Ω 6.9766 Ω 453.21 μ H 2 450.000 000 MHz

*
Oe1
CA

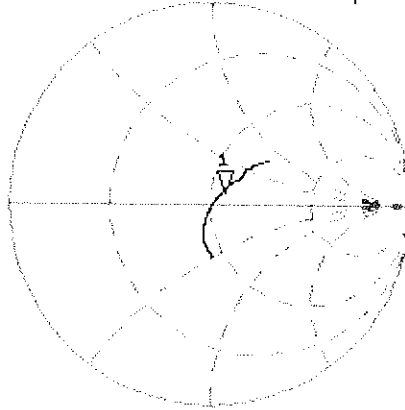

Avg
16

H1d

CH2 S11 LOG 5 dB/REF -20 dB 1: -21.413 dB 2 450.000 000 MHz

CA

Avg
16

H1d

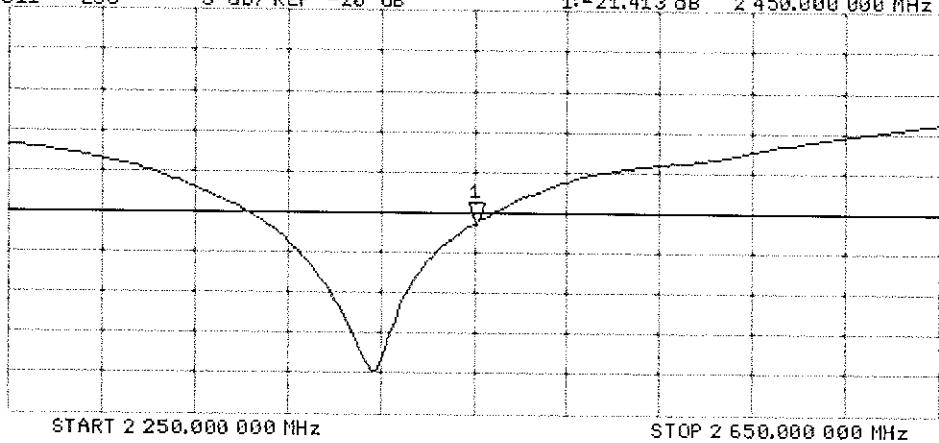

DASY5 Validation Report for Body TSL

Date: 17.08.2017

Test Laboratory: SPEAG, Zurich, Switzerland

DUT: Dipole 2450 MHz; Type: D2450V2; Serial: D2450V2 - SN: 719

Communication System: UID 0 - CW; Frequency: 2450 MHz

Medium parameters used: $f = 2450$ MHz; $\sigma = 2.03$ S/m; $\epsilon_r = 51.9$; $\rho = 1000$ kg/m³

Phantom section: Flat Section

Measurement Standard: DASY5 (IEEE/IEC/ANSI C63.19-2011)

DASY52 Configuration:

- Probe: EX3DV4 - SN7349; ConvF(8.1, 8.1, 8.1); Calibrated: 31.05.2017;
- Sensor-Surface: 1.4mm (Mechanical Surface Detection)
- Electronics: DAE4 Sn601; Calibrated: 28.03.2017
- Phantom: Flat Phantom 5.0 (back); Type: QD 000 P50 AA; Serial: 1002
- DASY52 52.10.0(1446); SEMCAD X 14.6.10(7417)

Dipole Calibration for Body Tissue/Pin=250 mW, d=10mm/Zoom Scan (7x7x7)/Cube 0:

Measurement grid: dx=5mm, dy=5mm, dz=5mm

Reference Value = 103.0 V/m; Power Drift = -0.07 dB

Peak SAR (extrapolated) = 25.2 W/kg

SAR(1 g) = 12.8 W/kg; SAR(10 g) = 6 W/kg

Maximum value of SAR (measured) = 19.8 W/kg

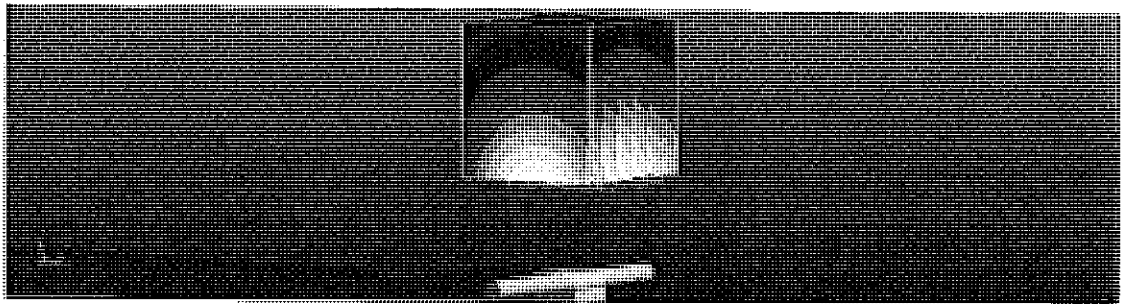
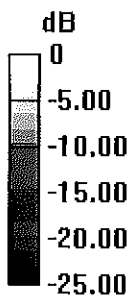

0 dB = 19.8 W/kg = 12.97 dBW/kg

Impedance Measurement Plot for Body TSL

17 Aug 2017 12:37:27
[CH1] S11 1 U FS 1: 51.379 Ω 8.1367 Ω 528.57 μ H 2 450.000 000 MHz

*
De1
C4

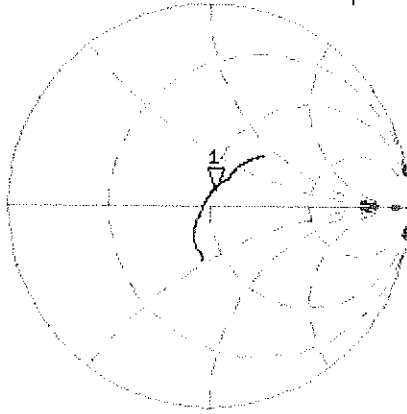

Avg
16

H1d

CH2 S11 LOG 5 dB/REF -20 dB 1: -21.809 dB 2 450.000 000 MHz

C4

Avg
16

H1d

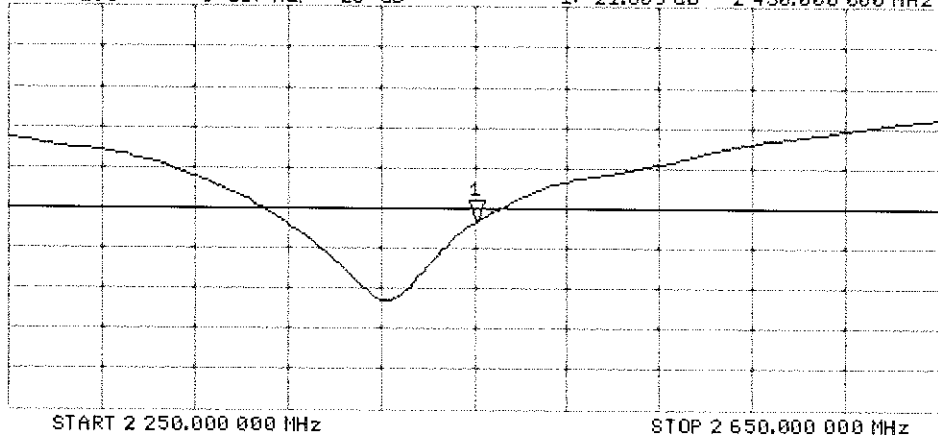

START 2 250.000 000 MHz

STOP 2 650.000 000 MHz

Certification of Calibration

Object: D2450V2 – SN: 719

Calibration procedure(s): Procedure for Calibration Extension for SAR Dipoles.

Extended Calibration date: 08/09/2018

Description: SAR Validation Dipole at 2450 MHz.

Calibration Equipment used:

Manufacturer	Model	Description	Cal Date	Cal Interval	Cal Due	Serial Number
Agilent	E4438C	ESG Vector Signal Generator	3/24/2017	Biennial	3/24/2019	MY42082385
Agilent	8753ES	S-Parameter Network Analyzer	9/14/2017	Annual	9/14/2018	US39170118
Amplifier Research	15S1G6	Amplifier	CBT	N/A	CBT	433971
Anritsu	ML2495A	Power Meter	11/28/2017	Annual	11/28/2018	1039008
Anritsu	MA2411B	Pulse Power Sensor	3/2/2018	Annual	3/2/2019	1207364
Anritsu	MA2411B	Pulse Power Sensor	11/15/2017	Annual	11/15/2018	1339007
Control Company	4040	Therm./Clock/Humidity Monitor	3/31/2017	Biennial	3/31/2019	170232394
Control Company	4352	Ultra Long Stem Thermometer	5/2/2017	Biennial	5/2/2019	170330156
Keysight	772D	Dual Directional Coupler	CBT	N/A	CBT	MY52180215
Keysight Technologies	85033E	Standard Mechanical Calibration Kit (DC to 9GHz, 3.5mm)	6/4/2018	Annual	6/4/2019	MY53401181
Mini-Circuits	BW-N20W5+	DC to 18 GHz Precision Fixed 20 dB Attenuator	CBT	N/A	CBT	N/A
Mini-Circuits	NLP-2950+	Low Pass Filter DC to 2700 MHz	CBT	N/A	CBT	N/A
Narda	4772-3	Attenuator (3dB)	CBT	N/A	CBT	9406
Pasternack	PE2209-10	Bidirectional Coupler	CBT	N/A	CBT	N/A
Pasternack	PE5011-1	Torque Wrench	7/19/2017	Biennial	7/19/2019	N/A
SPEAG	DAE4	Dasy Data Acquisition Electronics	3/7/2018	Annual	3/7/2019	1368
SPEAG	DAE4	Dasy Data Acquisition Electronics	8/9/2017	Annual	8/9/2018	1323
SPEAG	DAK-3.5	Dielectric Assessment Kit	9/12/2017	Annual	9/12/2018	1091
SPEAG	ES3DV3	SAR Probe	3/13/2018	Annual	3/13/2019	3319
SPEAG	ES3DV3	SAR Probe	8/14/2017	Annual	8/14/2018	3332

Measurement Uncertainty = $\pm 23\%$ (k=2)

	Name	Function	Signature
Calibrated By:	Brodie Halfoster	Test Engineer	<i>BRODIE HALFOSTER</i>
Approved By:	Kaitlin O'Keefe	Senior Technical Manager	<i>KOK</i>

DIPOLE CALIBRATION EXTENSION

Per KDB 865664 D01, calibration intervals of up to three years may be considered for reference dipoles when it is demonstrated that the SAR target, impedance and return loss of a dipole have remained stable according to the following requirements:

1. The measured SAR does not deviate more than 10% from the target on the calibration certificate.
2. The return-loss does not deviate more than 20% from the previous measurement and meets the required 20dB minimum return-loss requirement.
3. The measurement of real or imaginary parts of impedance does not deviate more than 5Ω from the previous measurement.

The following dipole was checked to pass the above 3 requirements to have 2-year calibration period from the calibration date:

Calibration Date	Extension Date	Certificate Electrical Delay (ns)	Certificate SAR Target Head (1g) W/kg @ 20.0 dBm	Measured Head SAR (1g) W/kg @ 20.0 dBm	Deviation 1g (%)	Certificate SAR Target Body (10g) W/kg @ 20.0 dBm	Measured Body SAR (10g) W/kg @ 20.0 dBm	Deviation 10g (%)	Certificate Impedance Head (Ohm) Real	Measured Impedance Head (Ohm) Real	Difference (Ohm) Real	Certificate Impedance Head (Ohm) Imaginary	Measured Impedance Head (Ohm) Imaginary	Difference (Ohm) Imaginary	Certificate Return Loss Head (dB)	Measured Return Loss Head (dB)	Deviation (%)	PASS/FAIL
8/17/2017	8/9/2018	1.150	5.19	5.46	5.20%	2.43	2.51	3.29%	55.7	53.9	1.8	7.0	2.9	4.1	-21.4	-25.4	-18.70%	PASS
Calibration Date	Extension Date	Certificate Electrical Delay (ns)	Certificate SAR Target Body (1g) W/kg @ 20.0 dBm	Measured Body SAR (1g) W/kg @ 20.0 dBm	Deviation 1g (%)	Certificate SAR Target Body (10g) W/kg @ 20.0 dBm	Measured Body SAR (10g) W/kg @ 20.0 dBm	Deviation 10g (%)	Certificate Impedance Body (Ohm) Real	Measured Impedance Body (Ohm) Real	Difference (Ohm) Real	Certificate Impedance Body (Ohm) Imaginary	Measured Impedance Body (Ohm) Imaginary	Difference (Ohm) Imaginary	Certificate Return Loss Body (dB)	Measured Return Loss Body (dB)	Deviation (%)	PASS/FAIL
8/17/2017	8/9/2018	1.150	5.01	5.19	3.59%	2.37	2.38	0.42%	51.4	50.2	1.2	8.1	5.9	2.2	-21.8	-24.6	-12.80%	PASS

Impedance & Return-Loss Measurement Plot for Head TSL

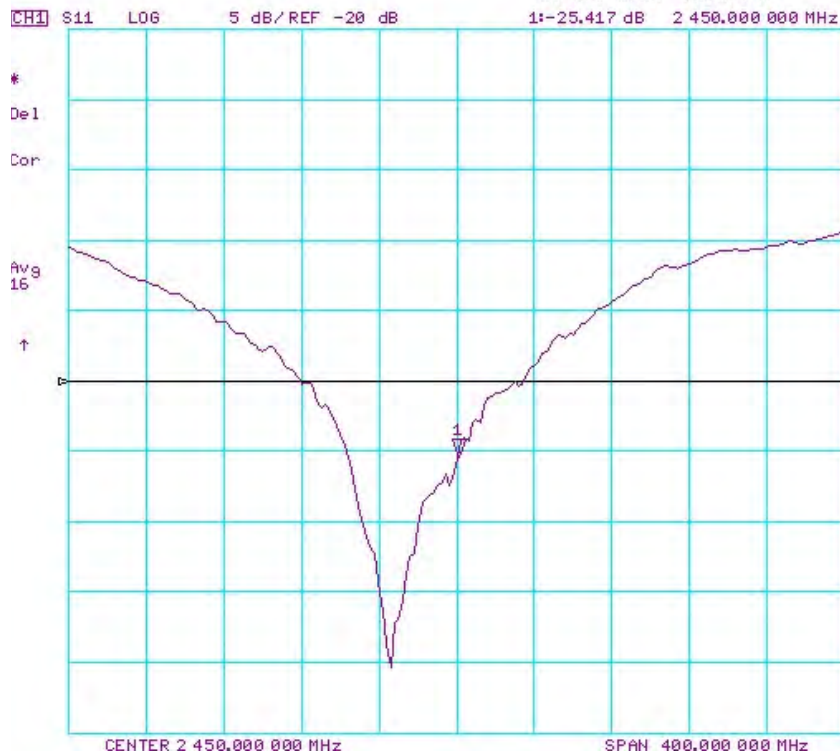
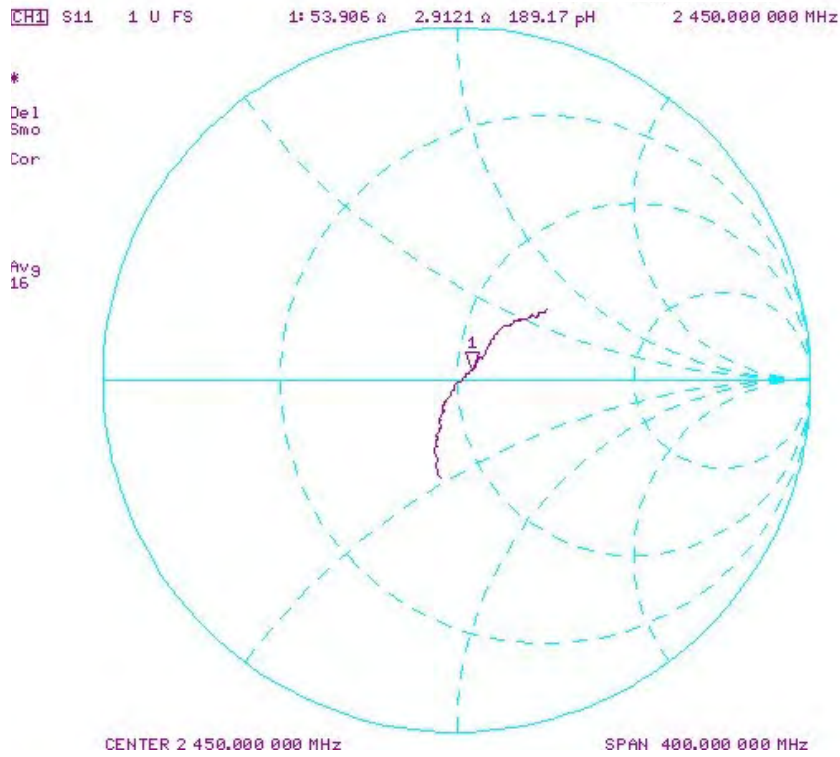

Impedance & Return-Loss Measurement Plot for Body TSL

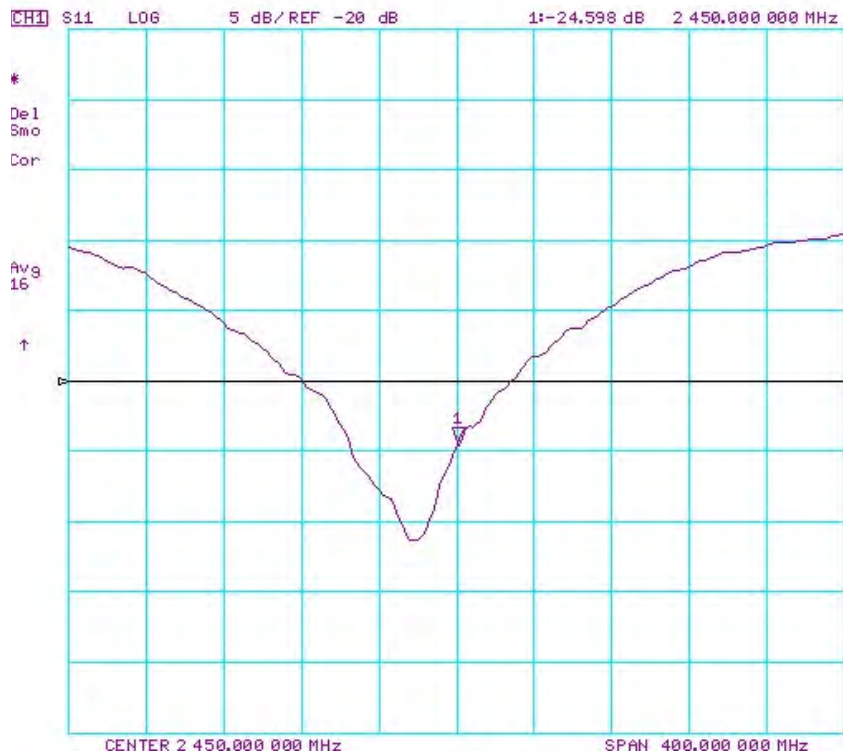
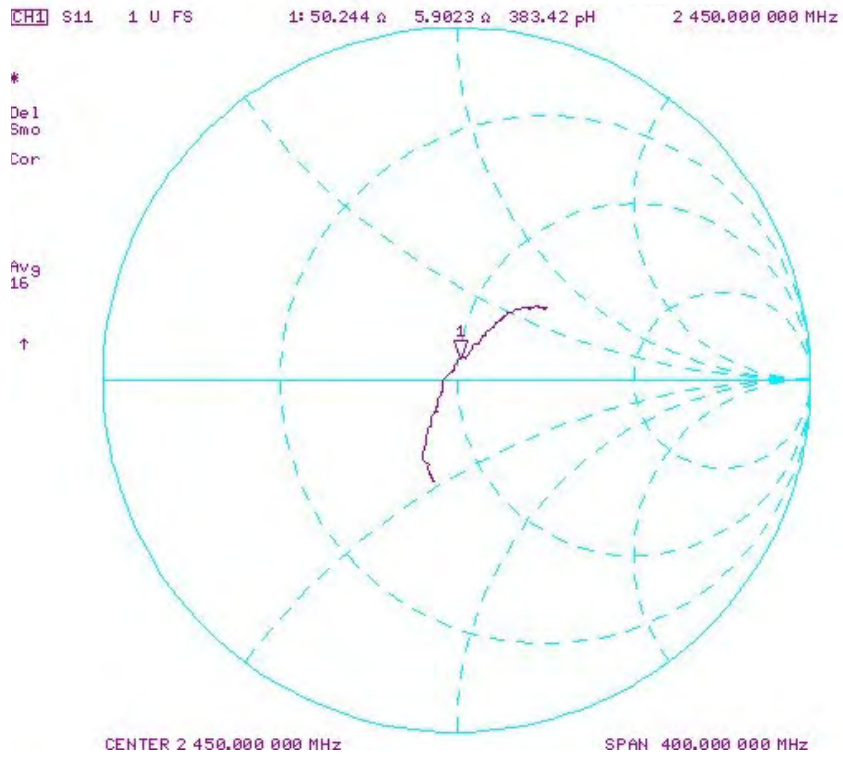

**Calibration Laboratory of
Schmid & Partner
Engineering AG**
Zeughausstrasse 43, 8004 Zurich, Switzerland



S Schweizerischer Kallbrlerdienst
C Service suisse d'etalonnage
S Servizio svizzero di taratura
S Swiss Callbration Service

Accredited by the Swiss Accreditation Service (SAS)
The Swiss Accreditation Service is one of the signatories to the EA
Multilateral Agreement for the recognition of calibration certificates

Accreditation No.: **SCS 0108**

Client **PC Test**

Certificate No: **D2450V2-797_Sep17**

CALIBRATION CERTIFICATE

Object **D2450V2 - SN:797**

Calibration procedure(s) **QA CAL-05.v9**
Calibration procedure for dipole validation kits above 700 MHz

Calibration date: **September 11, 2017**

SCV
10/03/2017
Extended PMV
9/20/2018

This calibration certificate documents the traceability to national standards, which realize the physical units of measurements (SI).
The measurements and the uncertainties with confidence probability are given on the following pages and are part of the certificate.

All calibrations have been conducted in the closed laboratory facility: environment temperature (22 ± 3)°C and humidity < 70%.

Calibration Equipment used (M&TE critical for calibration)

Primary Standards	ID #	Cal Date (Certificate No.)	Scheduled Calibration
Power meter NRP	SN: 104778	04-Apr-17 (No. 217-02521/02522)	Apr-18
Power sensor NRP-Z91	SN: 103244	04-Apr-17 (No. 217-02521)	Apr-18
Power sensor NRP-Z91	SN: 103245	04-Apr-17 (No. 217-02522)	Apr-18
Reference 20 dB Attenuator	SN: 5058 (20k)	07-Apr-17 (No. 217-02528)	Apr-18
Type-N mismatch combination	SN: 5047.2 / 08327	07-Apr-17 (No. 217-02529)	Apr-18
Reference Probe EX3DV4	SN: 7349	31-May-17 (No. EX3-7349_May17)	May-18
DAE4	SN: 601	28-Mar-17 (No. DAE4-601_Mar17)	Mar-18
Secondary Standards	ID #	Check Date (in house)	Scheduled Check
Power meter EPM-442A	SN: GB37480704	07-Oct-15 (in house check Oct-16)	In house check: Oct-18
Power sensor HP 8481A	SN: US37292783	07-Oct-15 (in house check Oct-16)	In house check: Oct-18
Power sensor HP 8481A	SN: MY41092317	07-Oct-15 (in house check Oct-16)	In house check: Oct-18
RF generator R&S SMT-08	SN: 100972	15-Jun-15 (in house check Oct-16)	In house check: Oct-18
Network Analyzer HP 8753E	SN: US37390585	18-Oct-01 (in house check Oct-16)	In house check: Oct-17

Calibrated by: **Michael Weber** Name: Michael Weber Function: Laboratory Technician

Approved by: **Katja Pokovic** Name: Katja Pokovic Function: Technical Manager

Signature
M. Weber
K. Pokovic

Issued: September 11, 2017

This calibration certificate shall not be reproduced except in full without written approval of the laboratory.

**Calibration Laboratory of
Schmid & Partner
Engineering AG**
Zeughausstrasse 43, 8004 Zurich, Switzerland



S Schweizerischer Kalibrierdienst
C Service suisse d'étalonnage
S Servizio svizzero di taratura
S Swiss Calibration Service

Accredited by the Swiss Accreditation Service (SAS)
The Swiss Accreditation Service is one of the signatories to the EA
Multilateral Agreement for the recognition of calibration certificates

Accreditation No.: **SCS 0108**

Glossary:

TSL tissue simulating liquid
ConvF sensitivity in TSL / NORM x,y,z
N/A not applicable or not measured

Calibration is Performed According to the Following Standards:

- a) IEEE Std 1528-2013, "IEEE Recommended Practice for Determining the Peak Spatial-Averaged Specific Absorption Rate (SAR) in the Human Head from Wireless Communications Devices: Measurement Techniques", June 2013
- b) IEC 62209-1, "Measurement procedure for the assessment of Specific Absorption Rate (SAR) from hand-held and body-mounted devices used next to the ear (frequency range of 300 MHz to 6 GHz)", July 2016
- c) IEC 62209-2, "Procedure to determine the Specific Absorption Rate (SAR) for wireless communication devices used in close proximity to the human body (frequency range of 30 MHz to 6 GHz)", March 2010
- d) KDB 865664, "SAR Measurement Requirements for 100 MHz to 6 GHz"

Additional Documentation:

- e) DASY4/5 System Handbook

Methods Applied and Interpretation of Parameters:

- *Measurement Conditions:* Further details are available from the Validation Report at the end of the certificate. All figures stated in the certificate are valid at the frequency indicated.
- *Antenna Parameters with TSL:* The dipole is mounted with the spacer to position its feed point exactly below the center marking of the flat phantom section, with the arms oriented parallel to the body axis.
- *Feed Point Impedance and Return Loss:* These parameters are measured with the dipole positioned under the liquid filled phantom. The impedance stated is transformed from the measurement at the SMA connector to the feed point. The Return Loss ensures low reflected power. No uncertainty required.
- *Electrical Delay:* One-way delay between the SMA connector and the antenna feed point. No uncertainty required.
- *SAR measured:* SAR measured at the stated antenna input power.
- *SAR normalized:* SAR as measured, normalized to an input power of 1 W at the antenna connector.
- *SAR for nominal TSL parameters:* The measured TSL parameters are used to calculate the nominal SAR result.

The reported uncertainty of measurement is stated as the standard uncertainty of measurement multiplied by the coverage factor $k=2$, which for a normal distribution corresponds to a coverage probability of approximately 95%.

Measurement Conditions

DASY system configuration, as far as not given on page 1.

DASY Version	DASY5	V52.10.0
Extrapolation	Advanced Extrapolation	
Phantom	Modular Flat Phantom	
Distance Dipole Center - TSL	10 mm	with Spacer
Zoom Scan Resolution	dx, dy, dz = 5 mm	
Frequency	2450 MHz \pm 1 MHz	

Head TSL parameters

The following parameters and calculations were applied.

	Temperature	Permittivity	Conductivity
Nominal Head TSL parameters	22.0 °C	39.2	1.80 mho/m
Measured Head TSL parameters	(22.0 \pm 0.2) °C	37.8 \pm 6 %	1.86 mho/m \pm 6 %
Head TSL temperature change during test	< 0.5 °C	----	----

SAR result with Head TSL

SAR averaged over 1 cm ³ (1 g) of Head TSL	Condition	
SAR measured	250 mW input power	13.5 W/kg
SAR for nominal Head TSL parameters	normalized to 1W	52.7 W/kg \pm 17.0 % (k=2)

SAR averaged over 10 cm ³ (10 g) of Head TSL	condition	
SAR measured	250 mW input power	6.28 W/kg
SAR for nominal Head TSL parameters	normalized to 1W	24.8 W/kg \pm 16.5 % (k=2)

Body TSL parameters

The following parameters and calculations were applied.

	Temperature	Permittivity	Conductivity
Nominal Body TSL parameters	22.0 °C	52.7	1.95 mho/m
Measured Body TSL parameters	(22.0 \pm 0.2) °C	51.9 \pm 6 %	2.04 mho/m \pm 6 %
Body TSL temperature change during test	< 0.5 °C	----	----

SAR result with Body TSL

SAR averaged over 1 cm ³ (1 g) of Body TSL	Condition	
SAR measured	250 mW input power	13.1 W/kg
SAR for nominal Body TSL parameters	normalized to 1W	51.1 W/kg \pm 17.0 % (k=2)

SAR averaged over 10 cm ³ (10 g) of Body TSL	condition	
SAR measured	250 mW input power	6.14 W/kg
SAR for nominal Body TSL parameters	normalized to 1W	24.2 W/kg \pm 16.5 % (k=2)

Appendix (Additional assessments outside the scope of SCS 0108)

Antenna Parameters with Head TSL

Impedance, transformed to feed point	53.8 Ω + 7.4 j Ω
Return Loss	- 21.9 dB

Antenna Parameters with Body TSL

Impedance, transformed to feed point	49.7 Ω + 9.1 j Ω
Return Loss	- 20.9 dB

General Antenna Parameters and Design

Electrical Delay (one direction)	1.152 ns
----------------------------------	----------

After long term use with 100W radiated power, only a slight warming of the dipole near the feedpoint can be measured.

The dipole is made of standard semirigid coaxial cable. The center conductor of the feeding line is directly connected to the second arm of the dipole. The antenna is therefore short-circuited for DC-signals. On some of the dipoles, small end caps are added to the dipole arms in order to improve matching when loaded according to the position as explained in the "Measurement Conditions" paragraph. The SAR data are not affected by this change. The overall dipole length is still according to the Standard.

No excessive force must be applied to the dipole arms, because they might bend or the soldered connections near the feedpoint may be damaged.

Additional EUT Data

Manufactured by	SPEAG
Manufactured on	January 24, 2006

DASY5 Validation Report for Head TSL

Date: 11.09.2017

Test Laboratory: SPEAG, Zurich, Switzerland

DUT: Dipole 2450 MHz; Type: D2450V2; Serial: D2450V2 - SN: 797

Communication System: UID 0 - CW; Frequency: 2450 MHz

Medium parameters used: $f = 2450$ MHz; $\sigma = 1.86$ S/m; $\epsilon_r = 37.8$; $\rho = 1000$ kg/m³

Phantom section: Flat Section

Measurement Standard: DASY5 (IEEE/IEC/ANSI C63.19-2011)

DASY52 Configuration:

- Probe: EX3DV4 - SN7349; ConvF(8.12, 8.12, 8.12); Calibrated: 31.05.2017;
- Sensor-Surface: 1.4mm (Mechanical Surface Detection)
- Electronics: DAE4 Sn601; Calibrated: 28.03.2017
- Phantom: Flat Phantom 5.0 (front); Type: QD 000 P50 AA; Serial: 1001
- DASY52 52.10.0(1446); SEMCAD X 14.6.10(7417)

Dipole Calibration for Head Tissue/ $P_{in}=250$ mW, $d=10$ mm/Zoom Scan (7x7x7)/Cube 0:

Measurement grid: $dx=5$ mm, $dy=5$ mm, $dz=5$ mm

Reference Value = 113.5 V/m; Power Drift = -0.08 dB

Peak SAR (extrapolated) = 26.9 W/kg

SAR(1 g) = 13.5 W/kg; SAR(10 g) = 6.28 W/kg

Maximum value of SAR (measured) = 21.6 W/kg

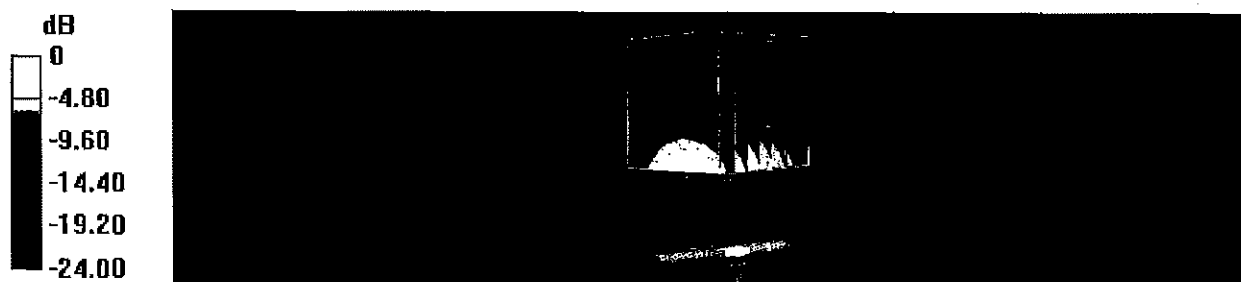

0 dB = 21.6 W/kg = 13.34 dBW/kg

Impedance Measurement Plot for Head TSL

11 Sep 2017 11:52:57

CH1 S11 1 U FS 1: 53.777 Ω 7.4395 Ω 483.28 μ H 2 450.000 000 MHz

*
DeI
CA
Avg
16
H1d

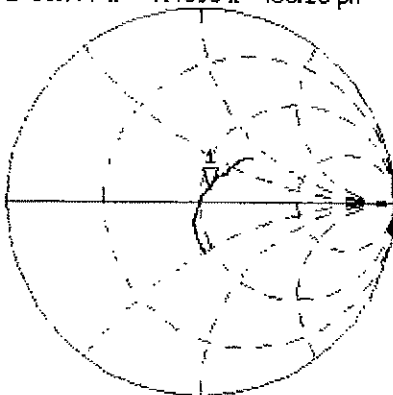

CH2 S11 LOG 5 dB/REF -20 dB 1: -21.911 dB 2 450.000 000 MHz

CA
Avg
16
H1d

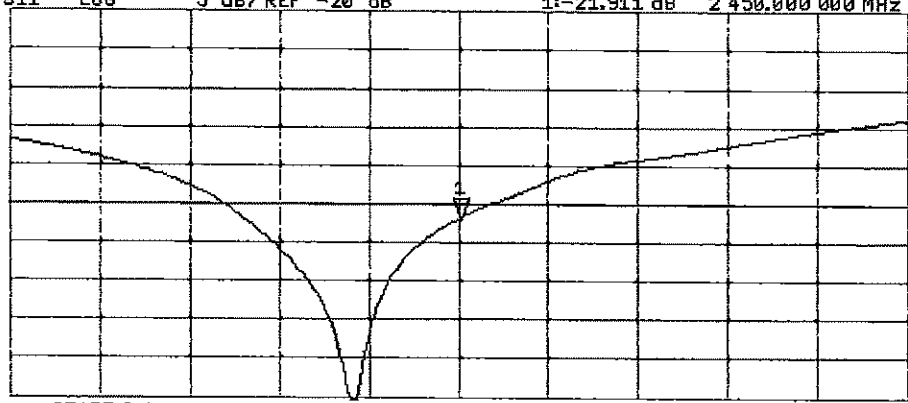

START 2 250.000 000 MHz

STOP 2 650.000 000 MHz

DASY5 Validation Report for Body TSL

Date: 11.09.2017

Test Laboratory: SPEAG, Zurich, Switzerland

DUT: Dipole 2450 MHz; Type: D2450V2; Serial: D2450V2 - SN: 797

Communication System: UID 0 - CW; Frequency: 2450 MHz

Medium parameters used: $f = 2450$ MHz; $\sigma = 2.04$ S/m; $\epsilon_r = 51.9$; $\rho = 1000$ kg/m³

Phantom section: Flat Section

Measurement Standard: DASY5 (IEEE/IEC/ANSI C63.19-2011)

DASY52 Configuration:

- Probe: EX3DV4 - SN7349; ConvF(8.1, 8.1, 8.1); Calibrated: 31.05.2017;
- Sensor-Surface: 1.4mm (Mechanical Surface Detection)
- Electronics: DAB4 Sn601; Calibrated: 28.03.2017
- Phantom: Flat Phantom 5.0 (back); Type: QD 000 P50 AA; Serial: 1002
- DASY52 52.10.0(1446); SEMCAD X 14.6.10(7417)

Dipole Calibration for Body Tissue/Pin=250 mW, d=10mm/Zoom Scan (7x7x7)/Cube 0:

Measurement grid: dx=5mm, dy=5mm, dz=5mm

Reference Value = 105.4 V/m; Power Drift = -0.08 dB

Peak SAR (extrapolated) = 25.6 W/kg

SAR(1 g) = 13.1 W/kg; SAR(10 g) = 6.14 W/kg

Maximum value of SAR (measured) = 20.3 W/kg

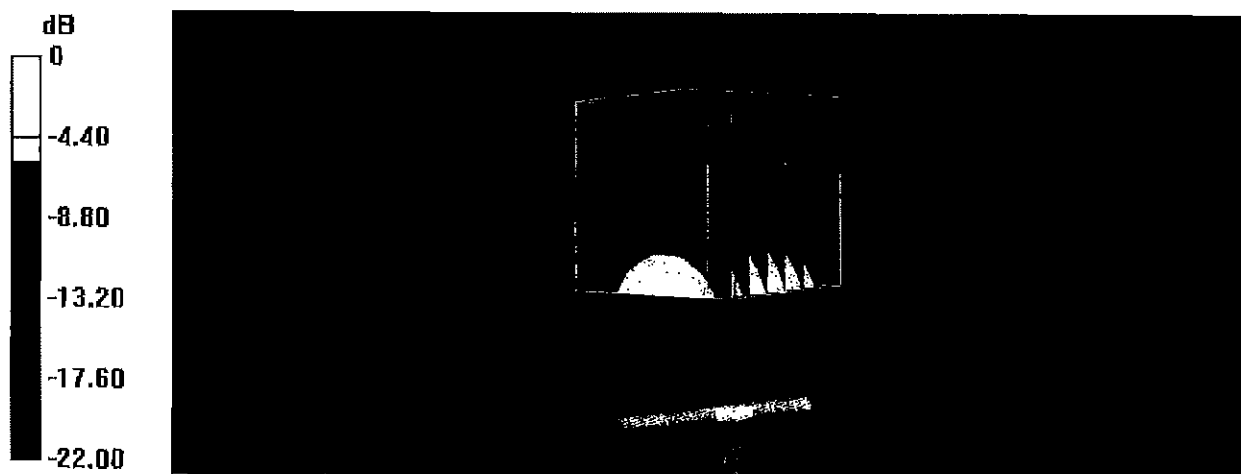

0 dB = 20.3 W/kg = 13.07 dBW/kg

Impedance Measurement Plot for Body TSL

11 Sep 2017 11:52:10

CH1 S11 1 U FS 1: 49.725 Ω 9.0703 Ω 589.22 pF 2 450.000 000 MHz

De1
CA

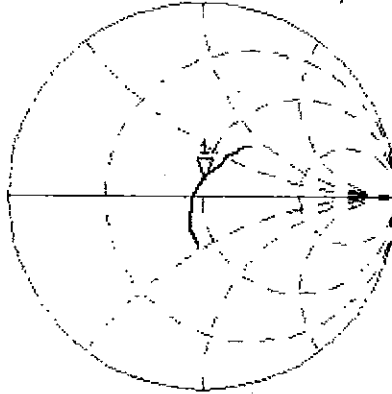

Avg
16

H1d

CH2 S11 LOG 5 dB/REF -20 dB 1: -20.854 dB 2 450.000 000 MHz

CA

Avg
16

H1d

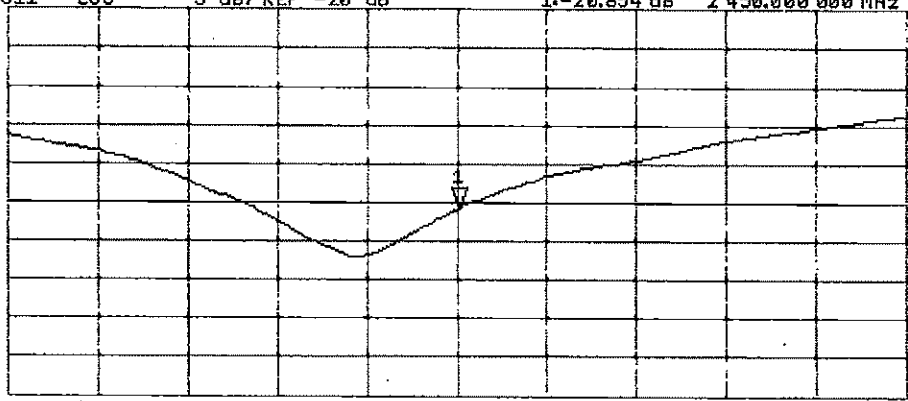

START 2 250.000 000 MHz

STOP 2 650.000 000 MHz

Certification of Calibration

Object: D2450V2 – SN: 797

Calibration procedure(s): Procedure for Calibration Extension for SAR Dipoles.

Extended Calibration date: September 11, 2018

Description: SAR Validation Dipole at 2450 MHz.

Calibration Equipment used:

Manufacturer	Model	Description	Cal Date	Cal Interval	Cal Due	Serial Number
Control Company	4040	Therm./Clock/Humidity Monitor	3/31/2017	Biennial	3/31/2019	170232394
Control Company	4352	Ultra Long Stem Thermometer	5/2/2017	Biennial	5/2/2019	170330156
Amplifier Research	1551G6	Amplifier	CBT	N/A	CBT	433971
Narda	4772-3	Attenuator {3dB}	CBT	N/A	CBT	9406
Keysight	772D	Dual Directional Coupler	CBT	N/A	CBT	MY52180215
Keysight Technologies	85033E	Standard Mechanical Calibration Kit (DC to 9GHz, 3.5mm)	6/4/2018	Annual	6/4/2019	MY53401181
Agilent	8753ES	S-Parameter Vector Network Analyzer	8/30/2018	Annual	8/30/2019	MY40003841
Mini-Circuits	BW-N20W5+	DC to 18 GHz Precision Fixed 20 dB Attenuator	CBT	N/A	CBT	N/A
SPEAG	DAK-3.5	Dielectric Assessment Kit	5/15/2018	Annual	5/15/2019	1070
SPEAG	EX3DV4	SAR Probe	7/20/2018	Annual	7/20/2019	7410
SPEAG	DAE4	Dasy Data Acquisition Electronics	7/11/2018	Annual	7/11/2019	1322
SPEAG	ES3DV3	SAR Probe	3/13/2018	Annual	3/13/2019	3319
SPEAG	DAE4	Dasy Data Acquisition Electronics	3/7/2018	Annual	3/7/2019	1368
Anritsu	MA2411B	Pulse Power Sensor	3/2/2018	Annual	3/2/2019	1207364
Anritsu	MA2411B	Pulse Power Sensor	3/2/2018	Annual	3/2/2019	1339018
Anritsu	ML2495A	Power Meter	10/22/2017	Annual	10/22/2018	1328004
Agilent	NS182A	MXG Vector Signal Generator	4/18/2018	Annual	4/18/2019	MY47420800
Seekonk	NC-100	Torque Wrench	7/11/2018	Annual	7/11/2019	N/A
MiniCircuits	VLF-6000+	Low Pass Filter	CBT	N/A	CBT	N/A
Narda	4014C-6	4 - 8 GHz SMA 6 dB Directional Coupler	CBT	N/A	CBT	N/A

Note: CBT (Calibrated Before Testing). Prior to testing, the measurement paths containing a cable, amplifier, attenuator, coupler or filter were connected to a calibrated source (i.e. a signal generator) to determine the losses of the measurement path.

Measurement Uncertainty = $\pm 23\%$ (k=2)

	Name	Function	Signature
Calibrated By:	Brodie Halfoster	Team Lead Engineer	<i>BRODIE HALFOSTER</i>
Approved By:	Kaitlin O'Keefe	Senior Technical Manager	<i>KOK</i>

DIPOLE CALIBRATION EXTENSION

Per KDB 865664 D01, calibration intervals of up to three years may be considered for reference dipoles when it is demonstrated that the SAR target, impedance and return loss of a dipole have remained stable according to the following requirements:

1. The measured SAR does not deviate more than 10% from the target on the calibration certificate.
2. The return-loss does not deviate more than 20% from the previous measurement and meets the required 20dB minimum return-loss requirement.
3. The measurement of real or imaginary parts of impedance does not deviate more than 5Ω from the previous measurement.

The following dipole was checked to pass the above 3 requirements to have 2-year calibration period from the calibration date:

Calibration Date	Extension Date	Certificate Electrical Delay (ns)	Certificate SAR Target Head (1g) W/kg @ 20.0 dBm	Measured Head SAR (1g) W/kg @ 20.0 dBm	Deviation 1g (%)	Certificate SAR Target Head (10g) W/kg @ 20.0 dBm	Measured Head SAR (10g) W/kg @ 20.0 dBm	Deviation 10g (%)	Certificate Impedance Head (Ohm) Real	Measured Impedance Head (Ohm) Real	Difference (Ohm) Real	Certificate Impedance Head (Ohm) Imaginary	Measured Impedance Head (Ohm) Imaginary	Difference (Ohm) Imaginary	Certificate Return Loss Head (dB)	Measured Return Loss Head (dB)	Deviation (%)	PASS/FAIL
9/11/2017	9/11/2018	1.152	5.27	5.52	4.74%	2.48	2.54	2.42%	53.8	49.8	4	7.4	7.1	0.3	-21.9	-23	-4.80%	PASS

Calibration Date	Extension Date	Certificate Electrical Delay (ns)	Certificate SAR Target Body (1g) W/kg @ 20.0 dBm	Measured Body SAR (1g) W/kg @ 20.0 dBm	Deviation 1g (%)	Certificate SAR Target Body (10g) W/kg @ 20.0 dBm	Measured Body SAR (10g) W/kg @ 20.0 dBm	Deviation 10g (%)	Certificate Impedance Body (Ohm) Real	Measured Impedance Body (Ohm) Real	Difference (Ohm) Real	Certificate Impedance Body (Ohm) Imaginary	Measured Impedance Body (Ohm) Imaginary	Difference (Ohm) Imaginary	Certificate Return Loss Body (dB)	Measured Return Loss Body (dB)	Deviation (%)	PASS/FAIL
9/11/2017	9/11/2018	1.152	5.11	5.17	1.17%	2.42	2.37	-2.07%	49.7	49.8	0.1	9.1	7.2	1.9	-20.9	-22.6	-8.20%	PASS

Impedance & Return-Loss Measurement Plot for Head TSL

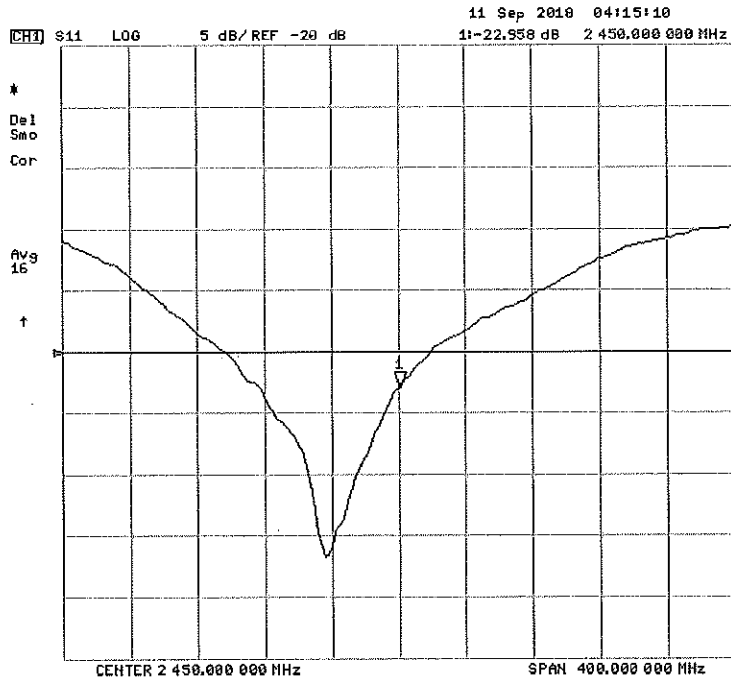
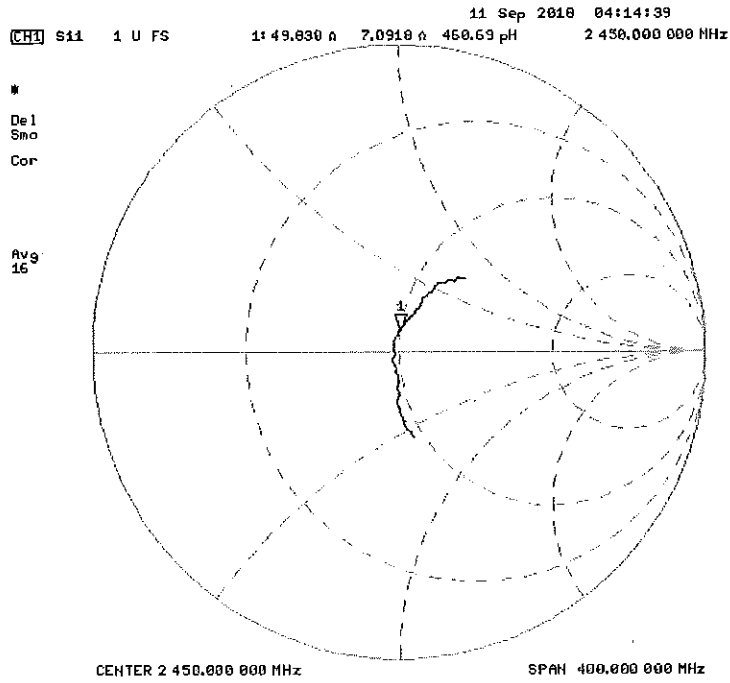

Impedance & Return-Loss Measurement Plot for Body TSL

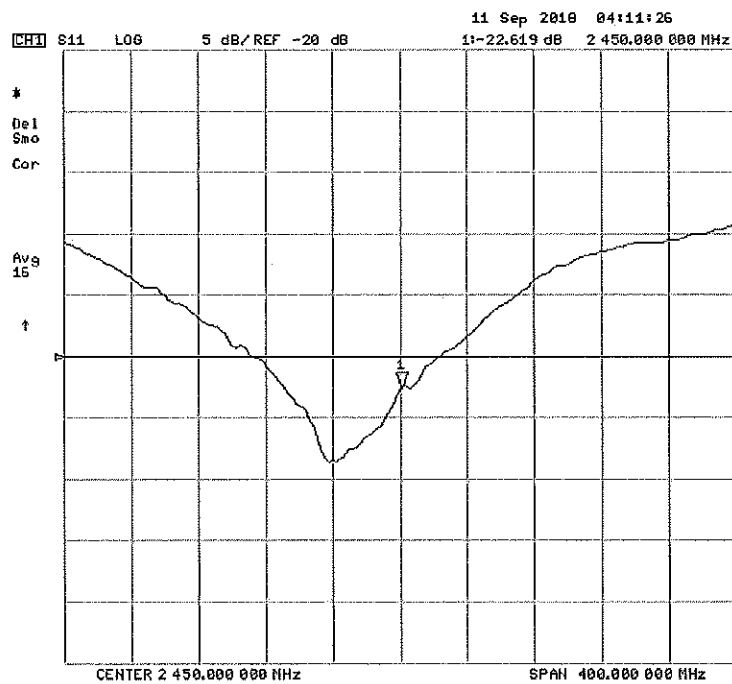
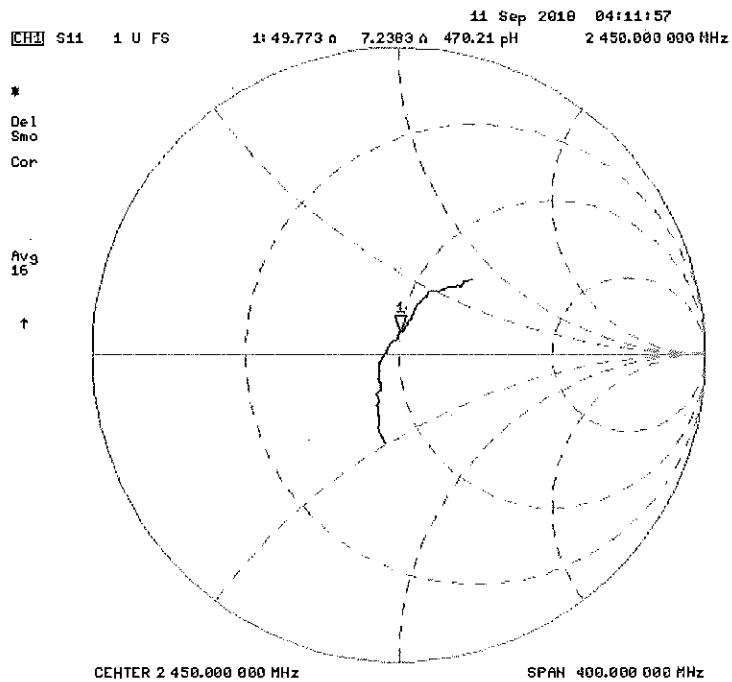



Accredited by the Swiss Accreditation Service (SAS)
The Swiss Accreditation Service is one of the signatories to the EA
Multilateral Agreement for the recognition of calibration certificates

Accreditation No.: **SCS 0108**

Client **PC Test**

Certificate No: **D2600V2-1004_Apr18**

CALIBRATION CERTIFICATE

Object **D2600V2 - SN:1004**

Calibration procedure(s) **OPTICAL BEAM
Calibration procedure for power evaluation with power 100 MHz**

Calibration date: **April 11, 2018**

*BN ✓ Extended
04-20-2019*

This calibration certificate documents the traceability to national standards, which realize the physical units of measurements (SI).
The measurements and the uncertainties with confidence probability are given on the following pages and are part of the certificate.

All calibrations have been conducted in the closed laboratory facility: environment temperature (22 ± 3)°C and humidity < 70%.

Calibration Equipment used (M&TE critical for calibration)

Primary Standards	ID #	Cal Date (Certificate No.)	Scheduled Calibration
Power meter NRP	SN: 104778	04-Apr-18 (No. 217-02672/02673)	Apr-19
Power sensor NRP-Z91	SN: 103244	04-Apr-18 (No. 217-02672)	Apr-19
Power sensor NRP-Z91	SN: 103245	04-Apr-18 (No. 217-02673)	Apr-19
Reference 20 dB Attenuator	SN: 5058 (20k)	04-Apr-18 (No. 217-02682)	Apr-19
Type-N mismatch combination	SN: 5047.2 / 06327	04-Apr-18 (No. 217-02683)	Apr-19
Reference Probe EX3DV4	SN: 7349	30-Dec-17 (No. EX3-7349_Dec17)	Dec-18
DAE4	SN: 601	26-Oct-17 (No. DAE4-601_Oct17)	Oct-18

Secondary Standards	ID #	Check Date (in house)	Scheduled Check
Power meter EPM-442A	SN: GB37480704	07-Oct-15 (in house check Oct-16)	In house check: Oct-18
Power sensor HP 8481A	SN: US37292783	07-Oct-15 (in house check Oct-16)	In house check: Oct-18
Power sensor HP 8481A	SN: MY41092317	07-Oct-15 (in house check Oct-16)	In house check: Oct-18
RF generator R&S SMT-06	SN: 100972	15-Jun-15 (in house check Oct-16)	In house check: Oct-18
Network Analyzer HP 8753E	SN: US37390585	18-Oct-01 (in house check Oct-17)	In house check: Oct-18

Calibrated by: **Michael Weber** (Name), **Laboratory Technician** (Function), *[Signature]* (Signature)

Approved by: **Katja Pokovic** (Name), **Technical Manager** (Function), *[Signature]* (Signature)

Issued: April 12, 2018

This calibration certificate shall not be reproduced except in full without written approval of the laboratory.



Accredited by the Swiss Accreditation Service (SAS)

Accreditation No.: **SCS 0108**

The Swiss Accreditation Service is one of the signatories to the EA Multilateral Agreement for the recognition of calibration certificates

Glossary:

TSL	tissue simulating liquid
ConvF	sensitivity in TSL / NORM x,y,z
N/A	not applicable or not measured

Calibration is Performed According to the Following Standards:

- IEEE Std 1528-2013, "IEEE Recommended Practice for Determining the Peak Spatial-Averaged Specific Absorption Rate (SAR) in the Human Head from Wireless Communications Devices: Measurement Techniques", June 2013
- IEC 62209-1, "Measurement procedure for the assessment of Specific Absorption Rate (SAR) from hand-held and body-mounted devices used next to the ear (frequency range of 300 MHz to 6 GHz)", July 2016
- IEC 62209-2, "Procedure to determine the Specific Absorption Rate (SAR) for wireless communication devices used in close proximity to the human body (frequency range of 30 MHz to 6 GHz)", March 2010
- KDB 865664, "SAR Measurement Requirements for 100 MHz to 6 GHz"

Additional Documentation:

- DASY4/5 System Handbook

Methods Applied and Interpretation of Parameters:

- Measurement Conditions:** Further details are available from the Validation Report at the end of the certificate. All figures stated in the certificate are valid at the frequency indicated.
- Antenna Parameters with TSL:** The dipole is mounted with the spacer to position its feed point exactly below the center marking of the flat phantom section, with the arms oriented parallel to the body axis.
- Feed Point Impedance and Return Loss:** These parameters are measured with the dipole positioned under the liquid filled phantom. The impedance stated is transformed from the measurement at the SMA connector to the feed point. The Return Loss ensures low reflected power. No uncertainty required.
- Electrical Delay:** One-way delay between the SMA connector and the antenna feed point. No uncertainty required.
- SAR measured:** SAR measured at the stated antenna input power.
- SAR normalized:** SAR as measured, normalized to an input power of 1 W at the antenna connector.
- SAR for nominal TSL parameters:** The measured TSL parameters are used to calculate the nominal SAR result.

The reported uncertainty of measurement is stated as the standard uncertainty of measurement multiplied by the coverage factor $k=2$, which for a normal distribution corresponds to a coverage probability of approximately 95%.

Measurement Conditions

DASY system configuration, as far as not given on page 1.

DASY Version	DASY5	V52.10.0
Extrapolation	Advanced Extrapolation	
Phantom	Modular Flat Phantom	
Distance Dipole Center - TSL	10 mm	with Spacer
Zoom Scan Resolution	dx, dy, dz = 5 mm	
Frequency	2600 MHz \pm 1 MHz	

Head TSL parameters

The following parameters and calculations were applied.

	Temperature	Permittivity	Conductivity
Nominal Head TSL parameters	22.0 °C	39.0	1.96 mho/m
Measured Head TSL parameters	(22.0 \pm 0.2) °C	37.8 \pm 6 %	2.03 mho/m \pm 6 %
Head TSL temperature change during test	< 0.5 °C	----	----

SAR result with Head TSL

SAR averaged over 1 cm³ (1 g) of Head TSL	Condition	
SAR measured	250 mW input power	14.3 W/kg
SAR for nominal Head TSL parameters	normalized to 1W	55.9 W/kg \pm 17.0 % (k=2)

SAR averaged over 10 cm³ (10 g) of Head TSL	condition	
SAR measured	250 mW input power	6.35 W/kg
SAR for nominal Head TSL parameters	normalized to 1W	25.1 W/kg \pm 16.5 % (k=2)

Body TSL parameters

The following parameters and calculations were applied.

	Temperature	Permittivity	Conductivity
Nominal Body TSL parameters	22.0 °C	52.5	2.16 mho/m
Measured Body TSL parameters	(22.0 \pm 0.2) °C	52.1 \pm 6 %	2.19 mho/m \pm 6 %
Body TSL temperature change during test	< 0.5 °C	----	----

SAR result with Body TSL

SAR averaged over 1 cm³ (1 g) of Body TSL	Condition	
SAR measured	250 mW input power	13.8 W/kg
SAR for nominal Body TSL parameters	normalized to 1W	54.8 W/kg \pm 17.0 % (k=2)

SAR averaged over 10 cm³ (10 g) of Body TSL	condition	
SAR measured	250 mW input power	6.20 W/kg
SAR for nominal Body TSL parameters	normalized to 1W	24.7 W/kg \pm 16.5 % (k=2)

Appendix (Additional assessments outside the scope of SCS 0108)

Antenna Parameters with Head TSL

Impedance, transformed to feed point	47.7 Ω - 5.7 j Ω
Return Loss	- 24.1 dB

Antenna Parameters with Body TSL

Impedance, transformed to feed point	46.0 Ω - 3.8 j Ω
Return Loss	- 24.9 dB

General Antenna Parameters and Design

Electrical Delay (one direction)	1.149 ns
----------------------------------	----------

After long term use with 100W radiated power, only a slight warming of the dipole near the feedpoint can be measured.

The dipole is made of standard semirigid coaxial cable. The center conductor of the feeding line is directly connected to the second arm of the dipole. The antenna is therefore short-circuited for DC-signals. On some of the dipoles, small end caps are added to the dipole arms in order to improve matching when loaded according to the position as explained in the "Measurement Conditions" paragraph. The SAR data are not affected by this change. The overall dipole length is still according to the Standard.

No excessive force must be applied to the dipole arms, because they might bend or the soldered connections near the feedpoint may be damaged.

Additional EUT Data

Manufactured by	SPEAG
Manufactured on	December 23, 2006

DASY5 Validation Report for Head TSL

Date: 11.04.2018

Test Laboratory: SPEAG, Zurich, Switzerland

DUT: Dipole 2600 MHz; Type: D2600V2; Serial: D2600V2 - SN: 1004

Communication System: UID 0 - CW; Frequency: 2600 MHz

Medium parameters used: $f = 2600$ MHz; $\sigma = 2.03$ S/m; $\epsilon_r = 37.8$; $\rho = 1000$ kg/m³

Phantom section: Flat Section

Measurement Standard: DASY5 (IEEE/IEC/ANSI C63.19-2011)

DASY52 Configuration:

- Probe: EX3DV4 - SN7349; ConvF(7.7, 7.7, 7.7); Calibrated: 30.12.2017;
- Sensor-Surface: 1.4mm (Mechanical Surface Detection)
- Electronics: DAE4 Sn601; Calibrated: 26.10.2017
- Phantom: Flat Phantom 5.0 (front); Type: QD 000 P50 AA; Serial: 1001
- DASY52 52.10.0(1446); SEMCAD X 14.6.10(7417)

Dipole Calibration for Head Tissue/Pin=250 mW, d=10mm/Zoom Scan (7x7x7)/Cube 0:

Measurement grid: dx=5mm, dy=5mm, dz=5mm

Reference Value = 118.5 V/m; Power Drift = -0.04 dB

Peak SAR (extrapolated) = 28.6 W/kg

SAR(1 g) = 14.3 W/kg; SAR(10 g) = 6.35 W/kg

Maximum value of SAR (measured) = 23.9 W/kg

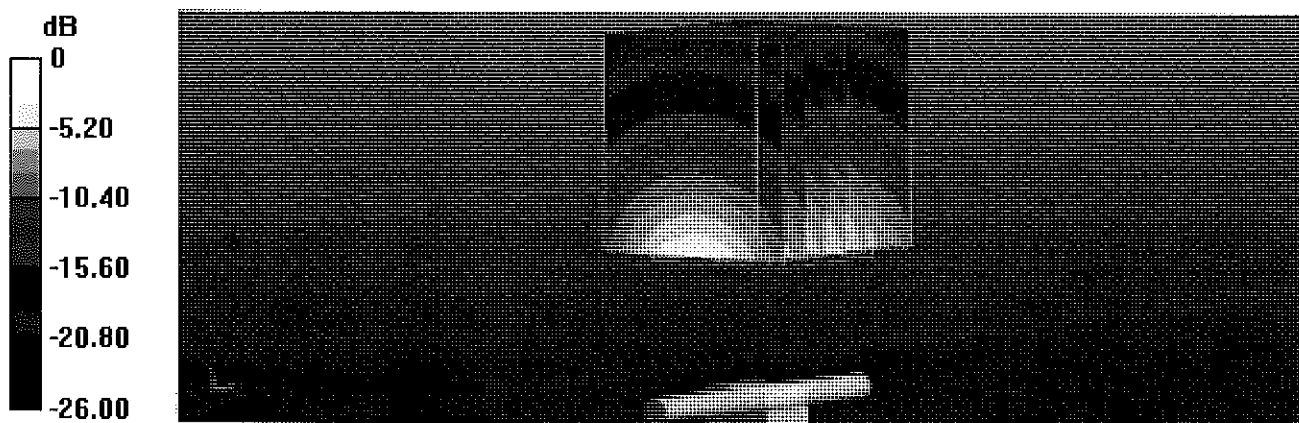

0 dB = 23.9 W/kg = 13.78 dBW/kg

Impedance Measurement Plot for Head TSL

11 Apr 2018 11:25:16

[CH1] S11 1 U FS 1: 47.721 Ω -5.6836 Ω 10.770 pF 2 500.000 000 MHz

*

De1

CA

Avg

16

H1 d

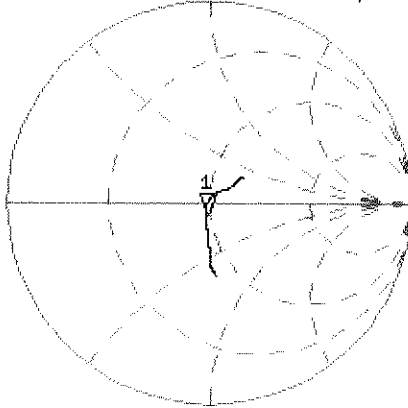

CH2 S11 LOG 5 dB/REF -20 dB 1: -24.073 dB 2 500.000 000 MHz

CA

Avg

16

H1 d

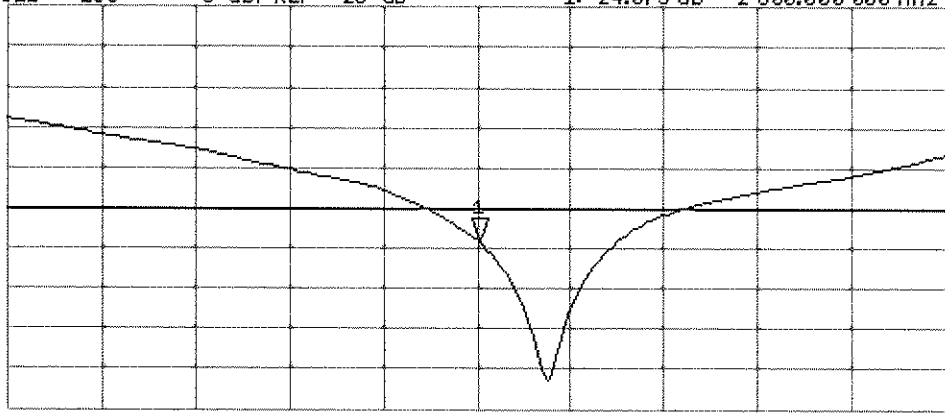

START 2 400.000 000 MHz

STOP 2 800.000 000 MHz

DASY5 Validation Report for Body TSL

Date: 11.04.2018

Test Laboratory: SPEAG, Zurich, Switzerland

DUT: Dipole 2600 MHz; Type: D2600V2; Serial: D2600V2 - SN: 1004

Communication System: UID 0 - CW; Frequency: 2600 MHz

Medium parameters used: $f = 2600$ MHz; $\sigma = 2.19$ S/m; $\epsilon_r = 52.1$; $\rho = 1000$ kg/m³

Phantom section: Flat Section

Measurement Standard: DASY5 (IEEE/IEC/ANSI C63.19-2011)

DASY52 Configuration:

- Probe: EX3DV4 - SN7349; ConvF(7.81, 7.81, 7.81); Calibrated: 30.12.2017;
- Sensor-Surface: 1.4mm (Mechanical Surface Detection)
- Electronics: DAE4 Sn601; Calibrated: 26.10.2017
- Phantom: Flat Phantom 5.0 (back); Type: QD 000 P50 AA; Serial: 1002
- DASY52 52.10.0(1446); SEMCAD X 14.6.10(7417)

Dipole Calibration for Body Tissue/Pin=250 mW, d=10mm/Zoom Scan (7x7x7)/Cube 0:

Measurement grid: dx=5mm, dy=5mm, dz=5mm

Reference Value = 108.5 V/m; Power Drift = -0.09 dB

Peak SAR (extrapolated) = 28.3 W/kg

SAR(1 g) = 13.8 W/kg; SAR(10 g) = 6.2 W/kg

Maximum value of SAR (measured) = 22.9 W/kg

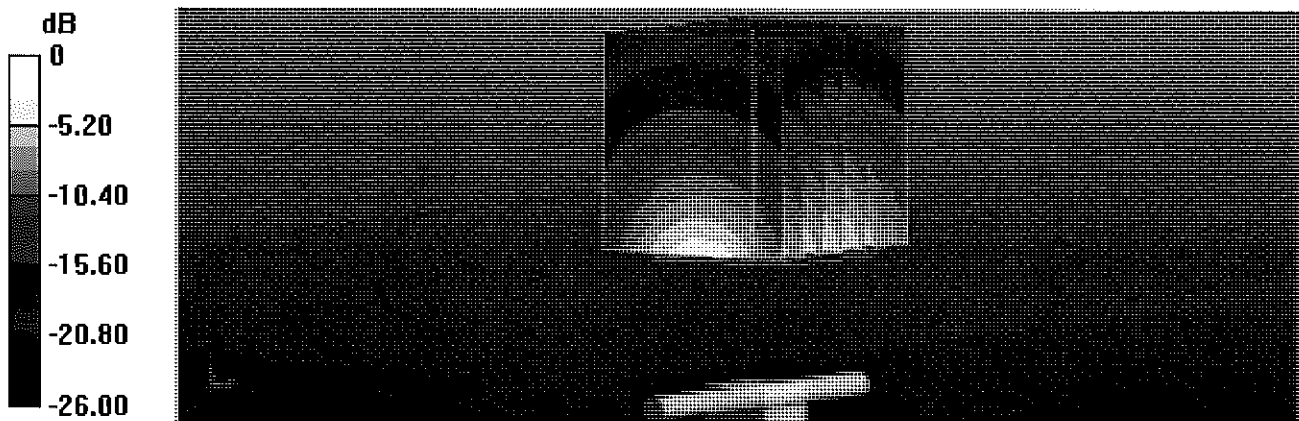

0 dB = 22.9 W/kg = 13.60 dBW/kg

Impedance Measurement Plot for Body TSL

11 Apr 2018 11:24:36

CH1 S11 1 U FS 1: 46.039 Ω -3.7520 Ω 16.315 pF 2 600.000 000 MHz

*
De1

CA

Avg
16

H1 d

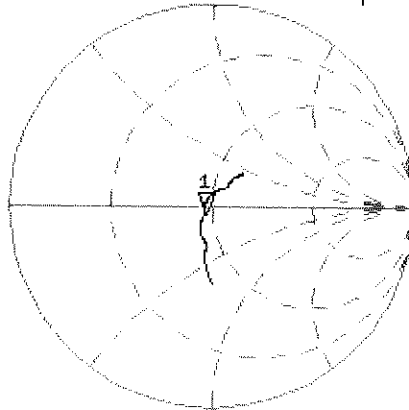

CH2 S11 LOG 5 dB/REF -20 dB 1:-24.921 dB 2 600.000 000 MHz

CA

Avg
16

H1 d

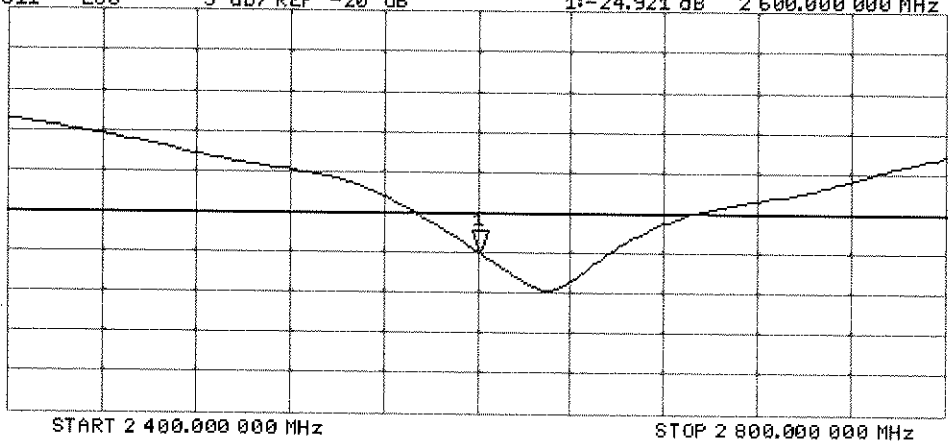

Certification of Calibration

Object: D2600V2 – SN: 1004

Calibration procedure(s): Procedure for Calibration Extension for SAR Dipoles.

Extension Calibration date: 4/11/2019

Description: SAR Validation Dipole at 2600 MHz.

Calibration Equipment used:

Manufacturer	Model	Description	Cal Date	Cal Interval	Cal Due	Serial Number
Agilent	8753ES	S-Parameter Network Analyzer	3/11/2019	Annual	3/11/2020	US39170122
Agilent	N5182A	MXG Vector Signal Generator	4/18/2018	Annual	4/18/2019	MY47420800
Amplifier Research	15S1G6	Amplifier	CBT	N/A	CBT	433971
Anritsu	MA2411B	Pulse Power Sensor	11/20/2018	Annual	11/20/2019	1027293
Anritsu	MA2411B	Pulse Power Sensor	10/30/2018	Annual	10/30/2019	1126066
Anritsu	ML2495A	Power Meter	10/21/2018	Annual	10/21/2019	941001
Control Company	4040	Therm./ Clock/ Humidity Monitor	10/9/2018	Biennial	10/9/2020	181647811
Control Company	4352	Ultra Long Stem Thermometer	5/2/2017	Biennial	5/2/2019	170330156
Keysight	772D	Dual Directional Coupler	CBT	N/A	CBT	MY52180215
Keysight Technologies	85033E	Standard Mechanical Calibration Kit (DC to 9GHz, 3.5mm)	6/4/2018	Annual	6/4/2019	MY53401181
MiniCircuits	VLF-6000+	Low Pass Filter	CBT	N/A	CBT	N/A
Mini-Circuits	BW-N20W5+	DC to 18 GHz Precision Fixed 20 dB Attenuator	CBT	N/A	CBT	N/A
Narda	4772-3	Attenuator (3dB)	CBT	N/A	CBT	9406
Pasternack	PE2209-10	Bidirectional Coupler	CBT	N/A	CBT	N/A
Seekonk	NC-100	Torque Wrench	7/11/2018	Annual	7/11/2019	N/A
SPEAG	EX3DV4	SAR Probe	6/25/2018	Annual	6/25/2019	7409
SPEAG	DAE4	Dasy Data Acquisition Electronics	6/18/2018	Annual	6/18/2019	1334
SPEAG	DAE4	Dasy Data Acquisition Electronics	2/13/2019	Annual	2/13/2020	665
SPEAG	EX3DV4	SAR Probe	2/19/2019	Annual	2/19/2020	7417
SPEAG	DAK-3.5	Dielectric Assessment Kit	9/11/2018	Annual	9/11/2019	1091

Measurement Uncertainty = $\pm 23\%$ (k=2)

	Name	Function	Signature
Calibrated By:	Brodie Halfoster	Test Engineer	<i>BRODIE HALFOSTER</i>
Approved By:	Kaitlin O'Keefe	Senior Technical Manager	<i>KOK</i>

DIPOLE CALIBRATION EXTENSION

Per KDB 865664 D01, calibration intervals of up to three years may be considered for reference dipoles when it is demonstrated that the SAR target, impedance and return loss of a dipole have remained stable according to the following requirements:

1. The measured SAR does not deviate more than 10% from the target on the calibration certificate.
2. The return-loss does not deviate more than 20% from the previous measurement and meets the required 20dB minimum return-loss requirement.
3. The measurement of real or imaginary parts of impedance does not deviate more than 5Ω from the previous measurement.

The following dipole was checked to pass the above 3 requirements to have 2-year calibration period from the calibration date:

Calibration Date	Extension Date	Certificate Electrical Delay (ns)	Certificate SAR Target Head (1g) W/kg @ 20.0 dBm	Measured Head SAR (1g) W/kg @ 20.0 dBm	Deviation 1g (%)	Certificate SAR Target Head (10g) W/kg @ 20.0 dBm	Measured Head SAR (10g) W/kg @ 20.0 dBm	Deviation 10g (%)	Certificate Impedance Head (Ohm) Real	Measured Impedance Head (Ohm) Real	Difference (Ohm) Real	Certificate Impedance Head (Ohm) Imaginary	Measured Impedance Head (Ohm) Imaginary	Difference (Ohm) Imaginary	Certificate Return Loss Head (dB)	Measured Return Loss Head (dB)	Deviation (%)	PASS/FAIL
4/11/2018	4/11/2019	1.140	5.59	5.51	-1.43%	2.51	2.47	-1.59%	47.7	48.5	0.8	-5.7	-5.1	0.6	-24.1	-25.6	-6.30%	PASS
Calibration Date	Extension Date	Certificate Electrical Delay (ns)	Certificate SAR Target Body (1g) W/kg @ 20.0 dBm	Measured Body SAR (1g) W/kg @ 20.0 dBm	Deviation 1g (%)	Certificate SAR Target Body (10g) W/kg @ 20.0 dBm	Measured Body SAR (10g) W/kg @ 20.0 dBm	Deviation 10g (%)	Certificate Impedance Body (Ohm) Real	Measured Impedance Body (Ohm) Real	Difference (Ohm) Real	Certificate Impedance Body (Ohm) Imaginary	Measured Impedance Body (Ohm) Imaginary	Difference (Ohm) Imaginary	Certificate Return Loss Body (dB)	Measured Return Loss Body (dB)	Deviation (%)	PASS/FAIL
4/11/2018	4/11/2019	1.140	5.48	5.65	3.10%	2.47	2.48	0.40%	46	46.6	0.6	-3.8	-4.7	0.9	-24.9	-24.5	1.80%	PASS

Impedance & Return-Loss Measurement Plot for Head TSL

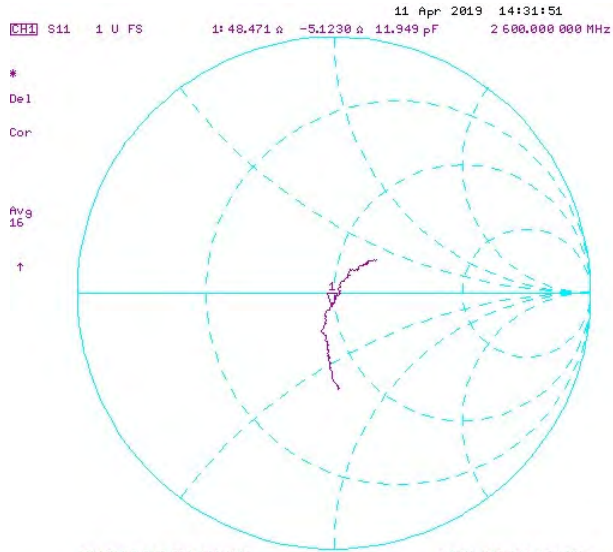

Impedance & Return-Loss Measurement Plot for Body TSL

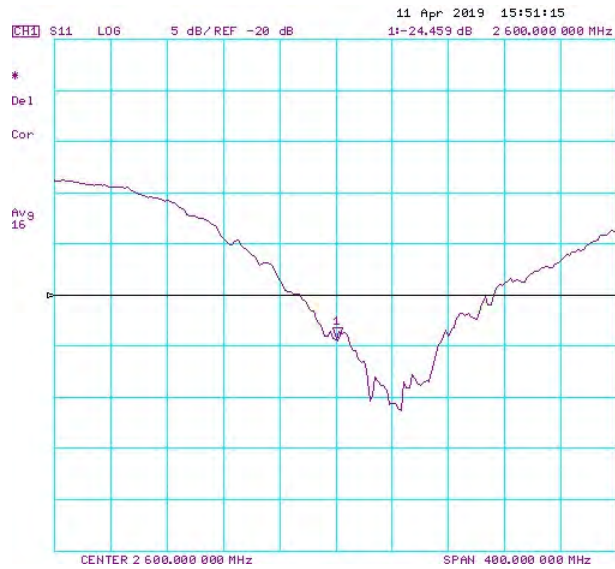
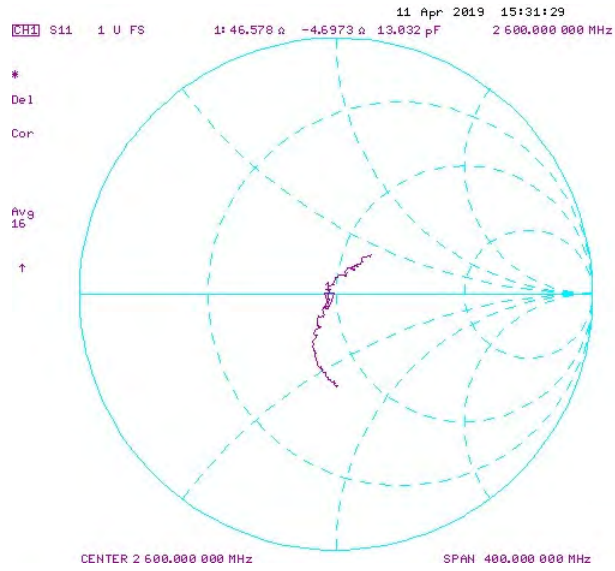



Accredited by the Swiss Accreditation Service (SAS)
The Swiss Accreditation Service is one of the signatories to the EA
Multilateral Agreement for the recognition of calibration certificates

Accreditation No.: **SCS 0108**

Client **PC Test**

Certificate No: **D5GHzV2-1057_Jan18**

CALIBRATION CERTIFICATE

Object **D5GHzV2 - SN:1057**

Calibration procedure(s) **QA CAL-22.v2
Calibration procedure for dipole validation kits between 3-6 GHz**

Calibration date: **January 16, 2018**

*BN ✓
01-25-2018*

This calibration certificate documents the traceability to national standards, which realize the physical units of measurements (SI).
The measurements and the uncertainties with confidence probability are given on the following pages and are part of the certificate.

*BN ✓
02/06/2019*

All calibrations have been conducted in the closed laboratory facility: environment temperature (22 ± 3)°C and humidity < 70%.

Calibration Equipment used (M&TE critical for calibration)

Primary Standards	ID #	Cal Date (Certificate No.)	Scheduled Calibration
Power meter NRP	SN: 104778	04-Apr-17 (No. 217-02521/02522)	Apr-18
Power sensor NRP-Z91	SN: 103244	04-Apr-17 (No. 217-02521)	Apr-18
Power sensor NRP-Z91	SN: 103245	04-Apr-17 (No. 217-02522)	Apr-18
Reference 20 dB Attenuator	SN: 5058 (20k)	07-Apr-17 (No. 217-02528)	Apr-18
Type-N mismatch combination	SN: 5047.2 / 06327	07-Apr-17 (No. 217-02529)	Apr-18
Reference Probe EX3DV4	SN: 3503	30-Dec-17 (No. EX3-3503_Dec17)	Dec-18
DAE4	SN: 601	26-Oct-17 (No. DAE4-601_Oct17)	Oct-18

Secondary Standards	ID #	Check Date (in house)	Scheduled Check
Power meter EPM-442A	SN: GB37490704	07-Oct-15 (in house check Oct-16)	In house check: Oct-18
Power sensor HP 8481A	SN: US37292783	07-Oct-15 (in house check Oct-16)	In house check: Oct-18
Power sensor HP 8481A	SN: MY41092317	07-Oct-15 (in house check Oct-16)	In house check: Oct-18
RF generator R&S SMT-06	SN: 100972	15-Jun-15 (in house check Oct-16)	In house check: Oct-18
Network Analyzer HP 8753E	SN: US37390585	18-Oct-01 (in house check Oct-17)	In house check: Oct-18

Calibrated by: **Leif Klysner** Name: **Leif Klysner** Function: **Laboratory Technician**

Signature
[Handwritten Signature]

Approved by: **Katja Pokovic** Name: **Katja Pokovic** Function: **Technical Manager**

Signature
[Handwritten Signature]

Issued: January 18, 2018

This calibration certificate shall not be reproduced except in full without written approval of the laboratory.



Accredited by the Swiss Accreditation Service (SAS)
The Swiss Accreditation Service is one of the signatories to the EA
Multilateral Agreement for the recognition of calibration certificates

Accreditation No.: **SCS 0108**

Glossary:

TSL	tissue simulating liquid
ConvF	sensitivity in TSL / NORM x,y,z
N/A	not applicable or not measured

Calibration is Performed According to the Following Standards:

- IEEE Std 1528-2013, "IEEE Recommended Practice for Determining the Peak Spatial-Averaged Specific Absorption Rate (SAR) in the Human Head from Wireless Communications Devices: Measurement Techniques", June 2013
- IEC 62209-1, "Measurement procedure for the assessment of Specific Absorption Rate (SAR) from hand-held and body-mounted devices used next to the ear (frequency range of 300 MHz to 6 GHz)", July 2016
- IEC 62209-2, "Procedure to determine the Specific Absorption Rate (SAR) for wireless communication devices used in close proximity to the human body (frequency range of 30 MHz to 6 GHz)", March 2010
- KDB 865664, "SAR Measurement Requirements for 100 MHz to 6 GHz"

Additional Documentation:

- DASY4/5 System Handbook

Methods Applied and Interpretation of Parameters:

- Measurement Conditions:* Further details are available from the Validation Report at the end of the certificate. All figures stated in the certificate are valid at the frequency indicated.
- Antenna Parameters with TSL:* The dipole is mounted with the spacer to position its feed point exactly below the center marking of the flat phantom section, with the arms oriented parallel to the body axis.
- Feed Point Impedance and Return Loss:* These parameters are measured with the dipole positioned under the liquid filled phantom. The impedance stated is transformed from the measurement at the SMA connector to the feed point. The Return Loss ensures low reflected power. No uncertainty required.
- Electrical Delay:* One-way delay between the SMA connector and the antenna feed point. No uncertainty required.
- SAR measured:* SAR measured at the stated antenna input power.
- SAR normalized:* SAR as measured, normalized to an input power of 1 W at the antenna connector.
- SAR for nominal TSL parameters:* The measured TSL parameters are used to calculate the nominal SAR result.

The reported uncertainty of measurement is stated as the standard uncertainty of measurement multiplied by the coverage factor $k=2$, which for a normal distribution corresponds to a coverage probability of approximately 95%.

Measurement Conditions

DASY system configuration, as far as not given on page 1.

DASY Version	DASY5	V52.10.0
Extrapolation	Advanced Extrapolation	
Phantom	Modular Flat Phantom V5.0	
Distance Dipole Center - TSL	10 mm	with Spacer
Zoom Scan Resolution	dx, dy = 4.0 mm, dz = 1.4 mm	Graded Ratio = 1.4 (Z direction)
Frequency	5200 MHz ± 1 MHz 5250 MHz ± 1 MHz 5600 MHz ± 1 MHz 5750 MHz ± 1 MHz 5800 MHz ± 1 MHz	

Head TSL parameters at 5250 MHz

The following parameters and calculations were applied.

	Temperature	Permittivity	Conductivity
Nominal Head TSL parameters	22.0 °C	35.9	4.71 mho/m
Measured Head TSL parameters	(22.0 ± 0.2) °C	36.2 ± 6 %	4.55 mho/m ± 6 %
Head TSL temperature change during test	< 0.5 °C	----	----

SAR result with Head TSL at 5250 MHz

SAR averaged over 1 cm³ (1 g) of Head TSL	Condition	
SAR measured	100 mW input power	7.91 W/kg
SAR for nominal Head TSL parameters	normalized to 1W	79.2 W/kg ± 19.9 % (k=2)

SAR averaged over 10 cm³ (10 g) of Head TSL	condition	
SAR measured	100 mW input power	2.28 W/kg
SAR for nominal Head TSL parameters	normalized to 1W	22.8 W/kg ± 19.5 % (k=2)

Head TSL parameters at 5600 MHz

The following parameters and calculations were applied.

	Temperature	Permittivity	Conductivity
Nominal Head TSL parameters	22.0 °C	35.5	5.07 mho/m
Measured Head TSL parameters	(22.0 ± 0.2) °C	35.8 ± 6 %	4.90 mho/m ± 6 %
Head TSL temperature change during test	< 0.5 °C	----	----

SAR result with Head TSL at 5600 MHz

SAR averaged over 1 cm ³ (1 g) of Head TSL	Condition	
SAR measured	100 mW input power	8.41 W/kg
SAR for nominal Head TSL parameters	normalized to 1W	84.1 W/kg ± 19.9 % (k=2)

SAR averaged over 10 cm ³ (10 g) of Head TSL	condition	
SAR measured	100 mW input power	2.40 W/kg
SAR for nominal Head TSL parameters	normalized to 1W	24.0 W/kg ± 19.5 % (k=2)

Head TSL parameters at 5750 MHz

The following parameters and calculations were applied.

	Temperature	Permittivity	Conductivity
Nominal Head TSL parameters	22.0 °C	35.4	5.22 mho/m
Measured Head TSL parameters	(22.0 ± 0.2) °C	35.5 ± 6 %	5.06 mho/m ± 6 %
Head TSL temperature change during test	< 0.5 °C	----	----

SAR result with Head TSL at 5750 MHz

SAR averaged over 1 cm ³ (1 g) of Head TSL	Condition	
SAR measured	100 mW input power	8.06 W/kg
SAR for nominal Head TSL parameters	normalized to 1W	80.5 W/kg ± 19.9 % (k=2)

SAR averaged over 10 cm ³ (10 g) of Head TSL	condition	
SAR measured	100 mW input power	2.30 W/kg
SAR for nominal Head TSL parameters	normalized to 1W	23.0 W/kg ± 19.5 % (k=2)

Body TSL parameters at 5200 MHz

The following parameters and calculations were applied.

	Temperature	Permittivity	Conductivity
Nominal Body TSL parameters	22.0 °C	49.0	5.30 mho/m
Measured Body TSL parameters	(22.0 ± 0.2) °C	47.3 ± 6 %	5.41 mho/m ± 6 %
Body TSL temperature change during test	< 0.5 °C	----	----

SAR result with Body TSL at 5200 MHz

SAR averaged over 1 cm ³ (1 g) of Body TSL	Condition	
SAR measured	100 mW input power	7.36 W/kg
SAR for nominal Body TSL parameters	normalized to 1W	73.1 W/kg ± 19.9 % (k=2)

SAR averaged over 10 cm ³ (10 g) of Body TSL	condition	
SAR measured	100 mW input power	2.06 W/kg
SAR for nominal Body TSL parameters	normalized to 1W	20.4 W/kg ± 19.5 % (k=2)

Body TSL parameters at 5250 MHz

The following parameters and calculations were applied.

	Temperature	Permittivity	Conductivity
Nominal Body TSL parameters	22.0 °C	48.9	5.36 mho/m
Measured Body TSL parameters	(22.0 ± 0.2) °C	47.2 ± 6 %	5.48 mho/m ± 6 %
Body TSL temperature change during test	< 0.5 °C	----	----

SAR result with Body TSL at 5250 MHz

SAR averaged over 1 cm ³ (1 g) of Body TSL	Condition	
SAR measured	100 mW input power	7.64 W/kg
SAR for nominal Body TSL parameters	normalized to 1W	75.9 W/kg ± 19.9 % (k=2)

SAR averaged over 10 cm ³ (10 g) of Body TSL	condition	
SAR measured	100 mW input power	2.13 W/kg
SAR for nominal Body TSL parameters	normalized to 1W	21.1 W/kg ± 19.5 % (k=2)

Body TSL parameters at 5600 MHz

The following parameters and calculations were applied.

	Temperature	Permittivity	Conductivity
Nominal Body TSL parameters	22.0 °C	48.5	5.77 mho/m
Measured Body TSL parameters	(22.0 ± 0.2) °C	46.6 ± 6 %	5.94 mho/m ± 6 %
Body TSL temperature change during test	< 0.5 °C	----	----

SAR result with Body TSL at 5600 MHz

SAR averaged over 1 cm ³ (1 g) of Body TSL	Condition	
SAR measured	100 mW input power	8.05 W/kg
SAR for nominal Body TSL parameters	normalized to 1W	79.9 W/kg ± 19.9 % (k=2)

SAR averaged over 10 cm ³ (10 g) of Body TSL	condition	
SAR measured	100 mW input power	2.25 W/kg
SAR for nominal Body TSL parameters	normalized to 1W	22.3 W/kg ± 19.5 % (k=2)

Body TSL parameters at 5750 MHz

The following parameters and calculations were applied.

	Temperature	Permittivity	Conductivity
Nominal Body TSL parameters	22.0 °C	48.3	5.94 mho/m
Measured Body TSL parameters	(22.0 ± 0.2) °C	46.3 ± 6 %	6.15 mho/m ± 6 %
Body TSL temperature change during test	< 0.5 °C	----	----

SAR result with Body TSL at 5750 MHz

SAR averaged over 1 cm ³ (1 g) of Body TSL	Condition	
SAR measured	100 mW input power	7.72 W/kg
SAR for nominal Body TSL parameters	normalized to 1W	76.7 W/kg ± 19.9 % (k=2)

SAR averaged over 10 cm ³ (10 g) of Body TSL	condition	
SAR measured	100 mW input power	2.14 W/kg
SAR for nominal Body TSL parameters	normalized to 1W	21.2 W/kg ± 19.5 % (k=2)

Body TSL parameters at 5800 MHz

The following parameters and calculations were applied.

	Temperature	Permittivity	Conductivity
Nominal Body TSL parameters	22.0 °C	48.2	6.00 mho/m
Measured Body TSL parameters	(22.0 ± 0.2) °C	46.2 ± 6 %	6.22 mho/m ± 6 %
Body TSL temperature change during test	< 0.5 °C	----	----

SAR result with Body TSL at 5800 MHz

SAR averaged over 1 cm ³ (1 g) of Body TSL	Condition	
SAR measured	100 mW input power	7.68 W/kg
SAR for nominal Body TSL parameters	normalized to 1W	76.3 W/kg ± 19.9 % (k=2)

SAR averaged over 10 cm ³ (10 g) of Body TSL	condition	
SAR measured	100 mW input power	2.13 W/kg
SAR for nominal Body TSL parameters	normalized to 1W	21.1 W/kg ± 19.5 % (k=2)

Appendix (Additional assessments outside the scope of SCS 0108)

Antenna Parameters with Head TSL at 5250 MHz

Impedance, transformed to feed point	50.0 Ω - 5.5 j Ω
Return Loss	- 25.2 dB

Antenna Parameters with Head TSL at 5600 MHz

Impedance, transformed to feed point	54.7 Ω - 2.1 j Ω
Return Loss	- 26.2 dB

Antenna Parameters with Head TSL at 5750 MHz

Impedance, transformed to feed point	52.7 Ω + 0.0 j Ω
Return Loss	- 31.5 dB

Antenna Parameters with Body TSL at 5200 MHz

Impedance, transformed to feed point	49.3 Ω - 6.7 j Ω
Return Loss	- 23.4 dB

Antenna Parameters with Body TSL at 5250 MHz

Impedance, transformed to feed point	48.4 Ω - 3.9 j Ω
Return Loss	- 27.4 dB

Antenna Parameters with Body TSL at 5600 MHz

Impedance, transformed to feed point	55.3 Ω - 1.6 j Ω
Return Loss	- 25.6 dB

Antenna Parameters with Body TSL at 5750 MHz

Impedance, transformed to feed point	52.6 Ω + 1.1 j Ω
Return Loss	- 31.2 dB

Antenna Parameters with Body TSL at 5800 MHz

Impedance, transformed to feed point	51.8 Ω - 0.4 j Ω
Return Loss	- 34.9 dB

General Antenna Parameters and Design

Electrical Delay (one direction)	1.203 ns
----------------------------------	----------

After long term use with 100W radiated power, only a slight warming of the dipole near the feedpoint can be measured.

The dipole is made of standard semirigid coaxial cable. The center conductor of the feeding line is directly connected to the second arm of the dipole. The antenna is therefore short-circuited for DC-signals. On some of the dipoles, small end caps are added to the dipole arms in order to improve matching when loaded according to the position as explained in the "Measurement Conditions" paragraph. The SAR data are not affected by this change. The overall dipole length is still according to the Standard.

No excessive force must be applied to the dipole arms, because they might bend or the soldered connections near the feedpoint may be damaged.

Additional EUT Data

Manufactured by	SPEAG
Manufactured on	November 27, 2006

Appendix (Additional assessments outside the scope of SCS 0108)

Measurement Conditions (f=5200 MHz)

DASY system configuration, as far as not given on page 1 and 3.

Phantom	SAM Head Phantom	For usage with cSAR3DV2-R/L
---------	------------------	-----------------------------

SAR result with SAM Head (Top)

SAR averaged over 1 cm ³ (1 g) of Head TSL	Condition	
SAR measured	100 mW input power	8.24 W/kg
SAR for nominal Head TSL parameters	normalized to 1W	82.6 W/kg ± 20.3 % (k=2)

SAR averaged over 10 cm ³ (10 g) of Head TSL	condition	
SAR measured	100 mW input power	2.35 W/kg
SAR for nominal Head TSL parameters	normalized to 1W	23.6 W/kg ± 19.9 % (k=2)

SAR result with SAM Head (Mouth)

SAR averaged over 1 cm ³ (1 g) of Head TSL	Condition	
SAR measured	100 mW input power	8.54 W/kg
SAR for nominal Head TSL parameters	normalized to 1W	85.6 W/kg ± 20.3 % (k=2)

SAR averaged over 10 cm ³ (10 g) of Head TSL	condition	
SAR measured	100 mW input power	2.37 W/kg
SAR for nominal Head TSL parameters	normalized to 1W	23.7 W/kg ± 19.9 % (k=2)

SAR result with SAM Head (Neck)

SAR averaged over 1 cm ³ (1 g) of Head TSL	Condition	
SAR measured	100 mW input power	8.14 W/kg
SAR for nominal Head TSL parameters	normalized to 1W	81.6 W/kg ± 20.3 % (k=2)

SAR averaged over 10 cm ³ (10 g) of Head TSL	condition	
SAR measured	100 mW input power	2.37 W/kg
SAR for nominal Head TSL parameters	normalized to 1W	23.7 W/kg ± 19.9 % (k=2)

SAR result with SAM Head (Ear)

SAR averaged over 1 cm ³ (1 g) of Head TSL	Condition	
SAR measured	100 mW input power	5.16 W/kg
SAR for nominal Head TSL parameters	normalized to 1W	51.7 W/kg ± 20.3 % (k=2)

SAR averaged over 10 cm ³ (10 g) of Head TSL	condition	
SAR measured	100 mW input power	1.76 W/kg
SAR for nominal Head TSL parameters	normalized to 1W	17.7 W/kg ± 19.9 % (k=2)

Measurement Conditions (f=5800 MHz)

DASY system configuration, as far as not given on page 1 and 3.

Phantom	SAM Head Phantom	For usage with cSAR3DV2-R/L
---------	------------------	-----------------------------

SAR result with SAM Head (Top)

SAR averaged over 1 cm ³ (1 g) of Head TSL	Condition	
SAR measured	100 mW input power	8.62 W/kg
SAR for nominal Head TSL parameters	normalized to 1W	86.3 W/kg ± 20.3 % (k=2)

SAR averaged over 10 cm ³ (10 g) of Head TSL	condition	
SAR measured	100 mW input power	2.41 W/kg
SAR for nominal Head TSL parameters	normalized to 1W	24.1 W/kg ± 19.9 % (k=2)

SAR result with SAM Head (Mouth)

SAR averaged over 1 cm ³ (1 g) of Head TSL	Condition	
SAR measured	100 mW input power	8.88 W/kg
SAR for nominal Head TSL parameters	normalized to 1W	88.9 W/kg ± 20.3 % (k=2)

SAR averaged over 10 cm ³ (10 g) of Head TSL	condition	
SAR measured	100 mW input power	2.44 W/kg
SAR for nominal Head TSL parameters	normalized to 1W	24.4 W/kg ± 19.9 % (k=2)

SAR result with SAM Head (Neck)

SAR averaged over 1 cm ³ (1 g) of Head TSL	Condition	
SAR measured	100 mW input power	8.33 W/kg
SAR for nominal Head TSL parameters	normalized to 1W	83.4 W/kg ± 20.3 % (k=2)

SAR averaged over 10 cm ³ (10 g) of Head TSL	condition	
SAR measured	100 mW input power	2.35 W/kg
SAR for nominal Head TSL parameters	normalized to 1W	23.5 W/kg ± 19.9 % (k=2)

SAR result with SAM Head (Ear)

SAR averaged over 1 cm ³ (1 g) of Head TSL	Condition	
SAR measured	100 mW input power	5.68 W/kg
SAR for nominal Head TSL parameters	normalized to 1W	56.8 W/kg ± 20.3 % (k=2)

SAR averaged over 10 cm ³ (10 g) of Head TSL	condition	
SAR measured	100 mW input power	1.89 W/kg
SAR for nominal Head TSL parameters	normalized to 1W	18.9 W/kg ± 19.9 % (k=2)

DASY5 Validation Report for Head TSL

Date: 11.01.2018

Test Laboratory: SPEAG, Zurich, Switzerland

DUT: Dipole D5GHzV2; Type: D5GHzV2; Serial: D5GHzV2 - SN:1057

Communication System: UID 0 - CW; Frequency: 5250 MHz, Frequency: 5600 MHz, Frequency: 5750 MHz
Medium parameters used: $f = 5250$ MHz; $\sigma = 4.55$ S/m; $\epsilon_r = 36.2$; $\rho = 1000$ kg/m³,
Medium parameters used: $f = 5600$ MHz; $\sigma = 4.9$ S/m; $\epsilon_r = 35.8$; $\rho = 1000$ kg/m³,
Medium parameters used: $f = 5750$ MHz; $\sigma = 5.06$ S/m; $\epsilon_r = 35.5$; $\rho = 1000$ kg/m³
Phantom section: Flat Section
Measurement Standard: DASY5 (IEEE/IEC/ANSI C63.19-2011)

DASY52 Configuration:

- Probe: EX3DV4 - SN3503; ConvF(5.51, 5.51, 5.51); Calibrated: 30.12.2017, ConvF(5.05, 5.05, 5.05); Calibrated: 30.12.2017, ConvF(4.98, 4.98, 4.98); Calibrated: 30.12.2017;
- Sensor-Surface: 1.4mm (Mechanical Surface Detection)
- Electronics: DAE4 Sn601 - modified; Calibrated: 26.10.2017
- Phantom: Flat Phantom 5.0 (front); Type: QD 000 P50 AA; Serial: 1001
- DASY52 52.10.0(1446); SEMCAD X 14.6.10(7417)

Dipole Calibration for Head Tissue/Pin=100mW, dist=10mm, f=5250 MHz/Zoom Scan, dist=1.4mm (8x8x7)/Cube 0: Measurement grid: dx=4mm, dy=4mm, dz=1.4mm
Reference Value = 72.54 V/m; Power Drift = -0.02 dB
Peak SAR (extrapolated) = 27.5 W/kg
SAR(1 g) = 7.91 W/kg; SAR(10 g) = 2.28 W/kg
Maximum value of SAR (measured) = 17.7 W/kg

Dipole Calibration for Head Tissue/Pin=100mW, dist=10mm, f=5600 MHz/Zoom Scan, dist=1.4mm (8x8x7)/Cube 0: Measurement grid: dx=4mm, dy=4mm, dz=1.4mm
Reference Value = 72.77 V/m; Power Drift = -0.07 dB
Peak SAR (extrapolated) = 32.2 W/kg
SAR(1 g) = 8.41 W/kg; SAR(10 g) = 2.4 W/kg
Maximum value of SAR (measured) = 19.7 W/kg

Dipole Calibration for Head Tissue/Pin=100mW, dist=10mm, f=5750 MHz/Zoom Scan, dist=1.4mm (8x8x7)/Cube 0: Measurement grid: dx=4mm, dy=4mm, dz=1.4mm
Reference Value = 70.93 V/m; Power Drift = -0.09 dB
Peak SAR (extrapolated) = 31.4 W/kg
SAR(1 g) = 8.06 W/kg; SAR(10 g) = 2.3 W/kg
Maximum value of SAR (measured) = 18.9 W/kg

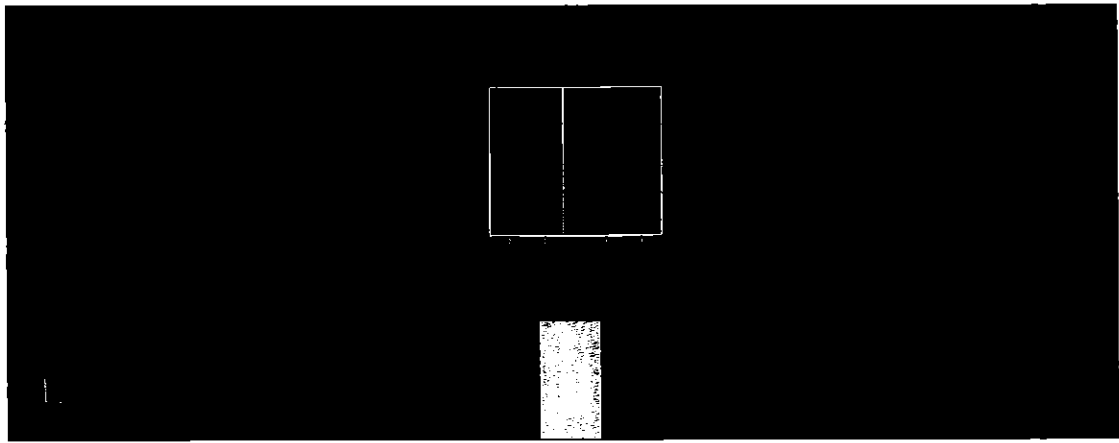
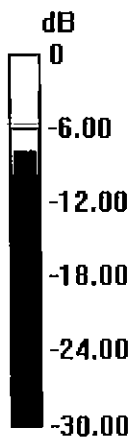

0 dB = 18.9 W/kg = 12.76 dBW/kg

Impedance Measurement Plot for Head TSL

11 Jan 2018 15:50:25

CH1 S11 1 U FS 1: 50.010 Ω -5.5215 Ω 5.4904 pF 5 250.000 000 MHz

De1
Cor
Avg
15
H1d

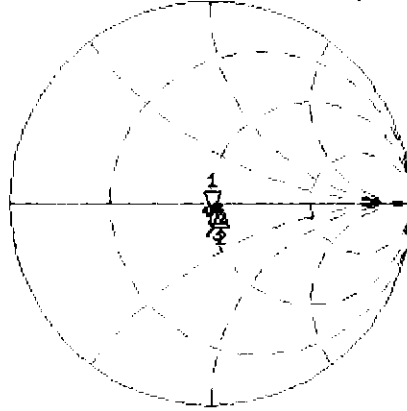

CH1 Markers
2: 54.660 Ω
-2.1445 Ω
5.60000 GHz
3: 52.729 Ω
-44.922 m Ω
5.75000 GHz

CH2 S11 LOG 5 dB/ REF -20 dB 1: -25.170 dB 5 250.000 000 MHz

Cor
Avg
15
H1d

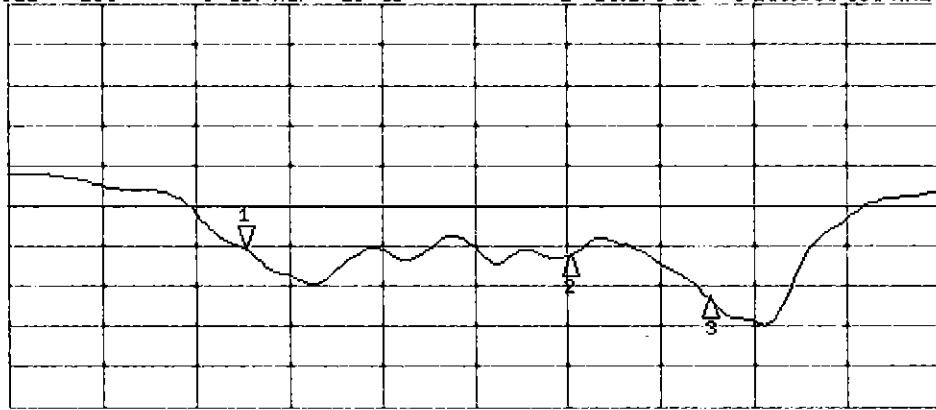

CH2 Markers
2: -26.187 dB
5.60000 GHz
3: -31.504 dB
5.75000 GHz

DASY5 Validation Report for Body TSL

Date: 10.01.2018

Test Laboratory: SPEAG, Zurich, Switzerland

DUT: Dipole D5GHzV2; Type: D5GHzV2; Serial: D5GHzV2 - SN:1057

Communication System: UID 0 - CW; Frequency: 5200 MHz, Frequency: 5250 MHz, Frequency: 5600 MHz, Frequency: 5750 MHz, Frequency: 5800 MHz

Medium parameters used: $f = 5200$ MHz; $\sigma = 5.41$ S/m; $\epsilon_r = 47.3$; $\rho = 1000$ kg/m³,

Medium parameters used: $f = 5250$ MHz; $\sigma = 5.48$ S/m; $\epsilon_r = 47.2$; $\rho = 1000$ kg/m³,

Medium parameters used: $f = 5600$ MHz; $\sigma = 5.94$ S/m; $\epsilon_r = 46.6$; $\rho = 1000$ kg/m³,

Medium parameters used: $f = 5750$ MHz; $\sigma = 6.15$ S/m; $\epsilon_r = 46.3$; $\rho = 1000$ kg/m³,

Medium parameters used: $f = 5800$ MHz; $\sigma = 6.22$ S/m; $\epsilon_r = 46.2$; $\rho = 1000$ kg/m³

Phantom section: Flat Section

Measurement Standard: DASY5 (IEEE/IEC/ANSI C63.19-2011)

DASY52 Configuration:

- Probe: EX3DV4 - SN3503; ConvF(5.35, 5.35, 5.35); Calibrated: 30.12.2017, ConvF(5.26, 5.26, 5.26); Calibrated: 30.12.2017, ConvF(4.65, 4.65, 4.65); Calibrated: 30.12.2017, ConvF(4.57, 4.57, 4.57); Calibrated: 30.12.2017, ConvF(4.53, 4.53, 4.53); Calibrated: 30.12.2017;
- Sensor-Surface: 1.4mm (Mechanical Surface Detection)
- Electronics: DAE4 Sn601; Calibrated: 26.10.2017
- Phantom: Flat Phantom 5.0 (back); Type: QD 000 P50 AA; Serial: 1002
- DASY52 52.10.0(1446); SEMCAD X 14.6.10(7417)

Dipole Calibration for Body Tissue/Pin=100mW, dist=10mm, f=5200 MHz/Zoom Scan, dist=1.4mm (8x8x7)/Cube 0: Measurement grid: dx=4mm, dy=4mm, dz=1.4mm

Reference Value = 64.05 V/m; Power Drift = -0.03 dB

Peak SAR (extrapolated) = 27.6 W/kg

SAR(1 g) = 7.36 W/kg; SAR(10 g) = 2.06 W/kg

Maximum value of SAR (measured) = 17.1 W/kg

Dipole Calibration for Body Tissue/Pin=100mW, dist=10mm, f=5250 MHz/Zoom Scan, dist=1.4mm (8x8x7)/Cube 0: Measurement grid: dx=4mm, dy=4mm, dz=1.4mm

Reference Value = 64.53 V/m; Power Drift = -0.02 dB

Peak SAR (extrapolated) = 29.4 W/kg

SAR(1 g) = 7.64 W/kg; SAR(10 g) = 2.13 W/kg

Maximum value of SAR (measured) = 17.9 W/kg

Dipole Calibration for Body Tissue/Pin=100mW, dist=10mm, f=5600 MHz/Zoom Scan, dist=1.4mm (8x8x7)/Cube 0: Measurement grid: dx=4mm, dy=4mm, dz=1.4mm
Reference Value = 65.09 V/m; Power Drift = -0.08 dB
Peak SAR (extrapolated) = 34.0 W/kg
SAR(1 g) = 8.05 W/kg; SAR(10 g) = 2.25 W/kg
Maximum value of SAR (measured) = 19.5 W/kg

Dipole Calibration for Body Tissue/Pin=100mW, dist=10mm, f=5750 MHz/Zoom Scan, dist=1.4mm (8x8x7)/Cube 0: Measurement grid: dx=4mm, dy=4mm, dz=1.4mm
Reference Value = 63.45 V/m; Power Drift = -0.06 dB
Peak SAR (extrapolated) = 32.9 W/kg
SAR(1 g) = 7.72 W/kg; SAR(10 g) = 2.14 W/kg
Maximum value of SAR (measured) = 18.9 W/kg

Dipole Calibration for Body Tissue/Pin=100mW, dist=10mm, f=5800 MHz/Zoom Scan, dist=1.4mm (8x8x7)/Cube 0: Measurement grid: dx=4mm, dy=4mm, dz=1.4mm
Reference Value = 63.14 V/m; Power Drift = -0.08 dB
Peak SAR (extrapolated) = 33.3 W/kg
SAR(1 g) = 7.68 W/kg; SAR(10 g) = 2.13 W/kg

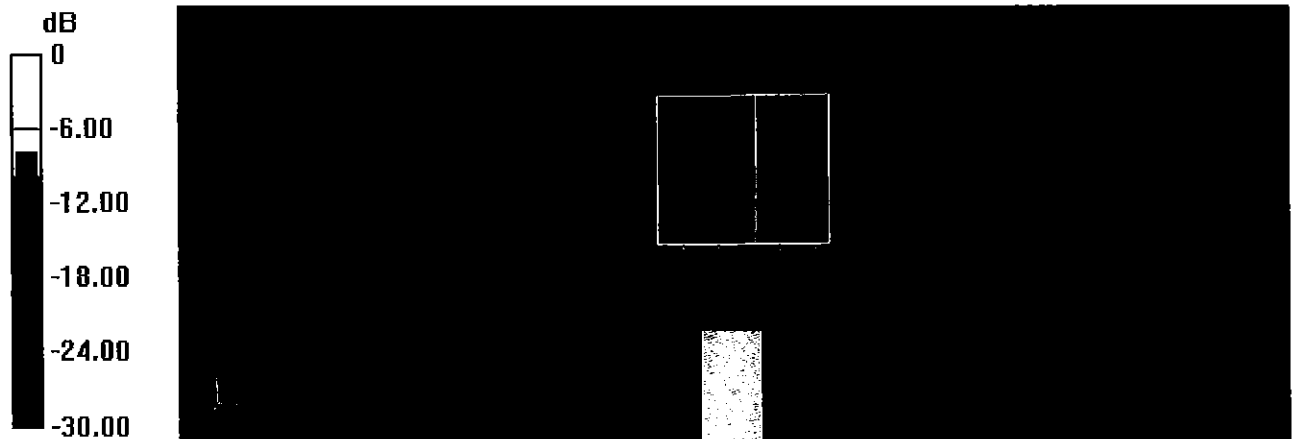

0 dB = 18.9 W/kg = 12.76 dBW/kg

Impedance Measurement Plot for Body TSL

10 Jan 2018 17:45:41

CH1 S11 1 U FS 1: 49.266 Ω -6.6719 Ω 4.5874 pF 5 200.000 000 MHz

*
Del
Cor
Avg 16
H1d

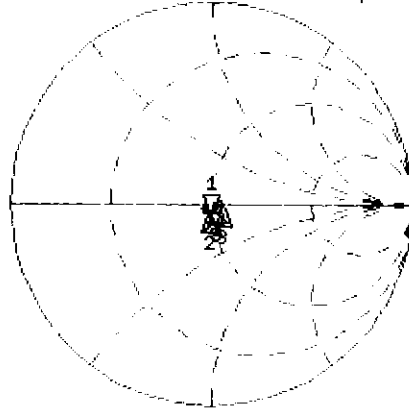

CH1 Markers

- 2: 48.449 Ω
-3.9297 Ω
5.25000 GHz
- 3: 55.279 Ω
-1.5723 Ω
5.60000 GHz
- 4: 52.627 Ω
1.0625 Ω
5.75000 GHz
- 5: 51.801 Ω
-375.00 m Ω
5.80000 GHz

CH2 S11 LOG 5 dB/REF -20 dB 1: -23.417 dB 5 200.000 000 MHz

Cor
Avg 16
H1d

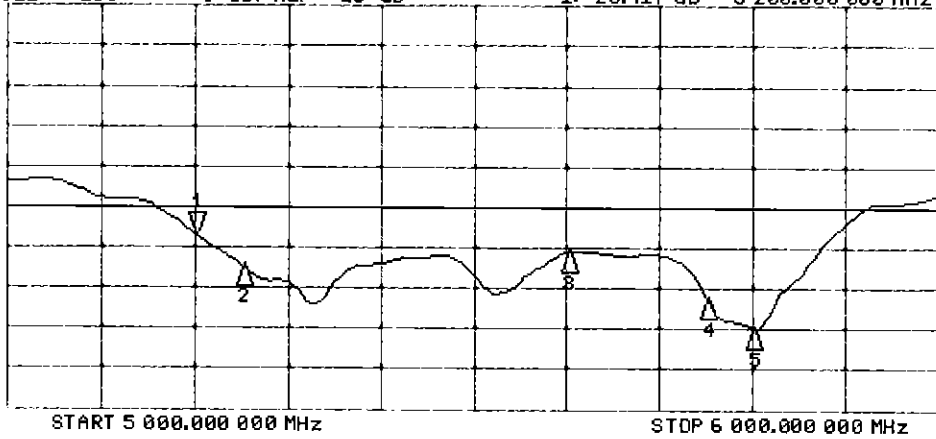

CH2 Markers

- 2: -27.356 dB
5.25000 GHz
- 3: -25.621 dB
5.60000 GHz
- 4: -31.162 dB
5.75000 GHz
- 5: -34.851 dB
5.80000 GHz

START 5 000.000 000 MHz

STOP 6 000.000 000 MHz

DASY5 Validation Report for SAM Head

Date: 16.01.2018

Test Laboratory: SPEAG, Zurich, Switzerland

DUT: Dipole 5GHz; Type: D5GHzV2; Serial: D5GHzV2 - SN:1057

Communication System: UID 0 - CW; Frequency: 5200 MHz, Frequency: 5800 MHz
Medium parameters used: $f = 5200$ MHz; $\sigma = 4.59$ S/m; $\epsilon_r = 36.5$; $\rho = 1000$ kg/m³ ,
Medium parameters used: $f = 5800$ MHz; $\sigma = 5.28$ S/m; $\epsilon_r = 35.4$; $\rho = 1000$ kg/m³
Measurement Standard: DASY5 (IEEE/IEC/ANSI C63.19-2007)

DASY52 Configuration:

- Probe: EX3DV4 - SN3503; ConvF(5.75, 5.75, 5.75); Calibrated: 30.12.2017, ConvF(4.96, 4.96, 4.96); Calibrated: 30.12.2017;
- Sensor-Surface: 1.4mm (Mechanical Surface Detection)
- Electronics: DAE4 Sn601; Calibrated: 26.10.2017
- Phantom: SAM Head
- DASY52 52.10.0(1446); SEMCAD X 14.6.10(7417)

SAM Head/Top - 5200/Zoom Scan (8x8x7)/Cube 0: Measurement grid: dx=4mm, dy=4mm, dz=1.4mm

Reference Value = 72.99 V/m; Power Drift = 0.04 dB
Peak SAR (extrapolated) = 30.6 W/kg
SAR(1 g) = 8.24 W/kg; SAR(10 g) = 2.35 W/kg
Maximum value of SAR (measured) = 19.7 W/kg

SAM Head/Top - 5800/Zoom Scan (8x8x7)/Cube 0: Measurement grid: dx=4mm, dy=4mm, dz=1.4mm

Reference Value = 73.00 V/m; Power Drift = 0.07 dB
Peak SAR (extrapolated) = 36.5 W/kg
SAR(1 g) = 8.62 W/kg; SAR(10 g) = 2.41 W/kg
Maximum value of SAR (measured) = 21.9 W/kg

SAM Head/Mouth - 5200/Zoom Scan (8x8x7)/Cube 0: Measurement grid: dx=4mm, dy=4mm, dz=1.4mm

Reference Value = 72.79 V/m; Power Drift = -0.04 dB
Peak SAR (extrapolated) = 29.5 W/kg
SAR(1 g) = 8.54 W/kg; SAR(10 g) = 2.37 W/kg
Maximum value of SAR (measured) = 20.7 W/kg

SAM Head/Mouth - 5800/Zoom Scan (8x8x7)/Cube 0: Measurement grid: dx=4mm, dy=4mm, dz=1.4mm

Reference Value = 71.69 V/m; Power Drift = -0.07 dB

Peak SAR (extrapolated) = 34.9 W/kg

SAR(1 g) = 8.88 W/kg; SAR(10 g) = 2.44 W/kg

Maximum value of SAR (measured) = 23.0 W/kg

SAM Head/Neck - 5200/Zoom Scan (8x8x7)/Cube 0: Measurement grid: dx=4mm, dy=4mm, dz=1.4mm

Reference Value = 72.48 V/m; Power Drift = 0.05 dB

Peak SAR (extrapolated) = 27.9 W/kg

SAR(1 g) = 8.14 W/kg; SAR(10 g) = 2.37 W/kg

Maximum value of SAR (measured) = 19.3 W/kg

SAM Head/Neck - 5800/Zoom Scan (8x8x7)/Cube 0: Measurement grid: dx=4mm, dy=4mm, dz=1.4mm

Reference Value = 72.90 V/m; Power Drift = 0.01 dB

Peak SAR (extrapolated) = 33.4 W/kg

SAR(1 g) = 8.33 W/kg; SAR(10 g) = 2.35 W/kg

Maximum value of SAR (measured) = 21.8 W/kg

SAM Head/Ear - 5200/Zoom Scan (8x8x7)/Cube 0: Measurement grid: dx=4mm, dy=4mm, dz=1.4mm

Reference Value = 54.68 V/m; Power Drift = 0.03 dB

Peak SAR (extrapolated) = 16.3 W/kg

SAR(1 g) = 5.16 W/kg; SAR(10 g) = 1.76 W/kg

Maximum value of SAR (measured) = 11.1 W/kg

SAM Head/Ear - 5800/Zoom Scan (8x8x7)/Cube 0: Measurement grid: dx=4mm, dy=4mm, dz=1.4mm

Reference Value = 56.96 V/m; Power Drift = -0.05 dB

Peak SAR (extrapolated) = 21.2 W/kg

SAR(1 g) = 5.68 W/kg; SAR(10 g) = 1.89 W/kg

Maximum value of SAR (measured) = 13.8 W/kg



0 dB = 13.8 W/kg = 11.40 dBW/kg

Certification of Calibration

Object: D5GHzV2 – SN: 1057

Calibration procedure(s): Procedure for Calibration Extension for SAR Dipoles.

Extension Calibration date: 1/16/2019

Description: SAR Validation Dipole at 5250, 5600, and 5750 MHz.

Calibration Equipment used:

Manufacturer	Model	Description	Cal Date	Cal Interval	Cal Due	Serial Number
Agilent	8753ES	S-Parameter Network Analyzer	2/8/2018	Annual	2/8/2019	US39170122
Agilent	N5182A	MXG Vector Signal Generator	4/18/2018	Annual	4/18/2019	MY47420800
Amplifier Research	15S1G6	Amplifier	CBT	N/A	CBT	433971
Anritsu	MA2411B	Pulse Power Sensor	3/2/2018	Annual	3/2/2019	1207364
Anritsu	MA2411B	Pulse Power Sensor	3/2/2018	Annual	3/2/2019	1339018
Anritsu	ML2495A	Power Meter	10/21/2018	Annual	10/21/2019	941001
Control Company	4040	Therm./Clock/Humidity Monitor	3/31/2017	Biennial	3/31/2019	170232394
Control Company	4352	Ultra Long Stem Thermometer	5/2/2017	Biennial	5/2/2019	170330156
Keysight	772D	Dual Directional Coupler	CBT	N/A	CBT	MY52180215
Keysight Technologies	85033E	Standard Mechanical Calibration Kit (DC to 9GHz, 3.5mm)	6/4/2018	Annual	6/4/2019	MY53401181
MiniCircuits	VLF-6000+	Low Pass Filter	CBT	N/A	CBT	N/A
Mini-Circuits	BW-N20W5+	DC to 18 GHz Precision Fixed 20 dB Attenuator	CBT	N/A	CBT	N/A
Narda	4772-3	Attenuator (3dB)	CBT	N/A	CBT	9406
Pasternack	PE2209-10	Bidirectional Coupler	CBT	N/A	CBT	N/A
Seekonk	NC-100	Torque Wrench	7/11/2018	Annual	7/11/2019	N/A
SPEAG	DAE4	Dasy Data Acquisition Electronics	10/3/2018	Annual	10/3/2019	1558
SPEAG	DAE4	Dasy Data Acquisition Electronics	6/18/2018	Annual	6/18/2019	1334
SPEAG	DAK-3.5	Dielectric Assessment Kit	9/11/2018	Annual	9/11/2019	1091
SPEAG	EX3DV4	SAR Probe	8/23/2018	Annual	8/23/2019	7308
SPEAG	EX3DV4	SAR Probe	6/25/2018	Annual	6/25/2019	7409

Measurement Uncertainty = $\pm 23\%$ (k=2)

	Name	Function	Signature
Calibrated By:	Brodie Halfoster	Test Engineer	<i>BRODIE HALFOSTER</i>
Approved By:	Kaitlin O'Keefe	Senior Technical Manager	<i>KOK</i>

DIPOLE CALIBRATION EXTENSION

Per KDB 865664 D01, calibration intervals of up to three years may be considered for reference dipoles when it is demonstrated that the SAR target, impedance and return loss of a dipole have remained stable according to the following requirements:

1. The measured SAR does not deviate more than 10% from the target on the calibration certificate.
2. The return-loss does not deviate more than 20% from the previous measurement and meets the required 20dB minimum return-loss requirement.
3. The measurement of real or imaginary parts of impedance does not deviate more than 5Ω from the previous measurement.

The following dipole was checked to pass the above 3 requirements to have 2-year calibration period from the calibration date:

Frequency (MHz)	Calibration Date	Extension Date	Certificate Electrical Delay (ns)	Certificate SAR Target Head (1g) W/kg @ 17.0 dBm	Measured Head SAR (1g) W/kg @ 17.0 dBm	Deviation 1g (%)	Certificate SAR Target Head (10g) W/kg @ 17.0 dBm	Measured Head SAR (10g) W/kg @ 17.0 dBm	Deviation 10g (%)	Certificate Impedance Head (Ohm) Real	Measured Impedance Head (Ohm) Real	Difference (Ohm) Real	Certificate Impedance Head (Ohm) Imaginary	Measured Impedance Head (Ohm) Imaginary	Difference (Ohm) Imaginary	Certificate Return Loss Head (dB)	Measured Return Loss Head (dB)	Deviation (%)	PASS/FAIL
5250	1/16/2018	1/16/2019	1.203	3.95	3.63	-8.33%	1.14	1.04	-8.77%	50	47.6	2.4	-5.5	-8.7	1.2	-25.2	-22.8	9.60%	PASS
5600	1/16/2018	1/16/2019	1.203	4.205	3.84	-8.88%	1.2	1.09	-9.17%	54.7	52.5	2.2	-2.1	1.6	3.7	-26.2	-30.6	-16.80%	PASS
5750	1/16/2018	1/16/2019	1.203	4.025	3.76	-6.58%	1.15	1.07	-6.96%	52.7	54.4	1.7	0	0.1	0.1	-31.5	-27.5	12.70%	PASS
Frequency (MHz)	Calibration Date	Extension Date	Certificate Electrical Delay (ns)	Certificate SAR Target Body (1g) W/kg @ 17.0 dBm	Measured Body SAR (1g) W/kg @ 17.0 dBm	Deviation 1g (%)	Certificate SAR Target Body (10g) W/kg @ 17.0 dBm	Measured Body SAR (10g) W/kg @ 17.0 dBm	Deviation 10g (%)	Certificate Impedance Body (Ohm) Real	Measured Impedance Body (Ohm) Real	Difference (Ohm) Real	Certificate Impedance Body (Ohm) Imaginary	Measured Impedance Body (Ohm) Imaginary	Difference (Ohm) Imaginary	Certificate Return Loss Body (dB)	Measured Return Loss Body (dB)	Deviation (%)	PASS/FAIL
5250	1/16/2018	1/16/2019	1.203	3.795	3.73	-1.71%	1.06	1.03	-2.37%	48.4	45.9	2.5	-3.9	-4	0.1	-27.4	-24.5	10.50%	PASS
5600	1/16/2018	1/16/2019	1.203	3.995	4.06	1.63%	1.12	1.12	0.49%	55.3	51	4.3	-1.6	2.8	4.4	-25.6	-30.7	-20.00%	PASS
5750	1/16/2018	1/16/2019	1.203	3.835	3.65	-4.82%	1.06	1.02	-3.77%	52.6	52.9	0.3	1.1	0.6	0.5	-31.2	-30.7	1.60%	PASS

Impedance & Return-Loss Measurement Plot for Head TSL

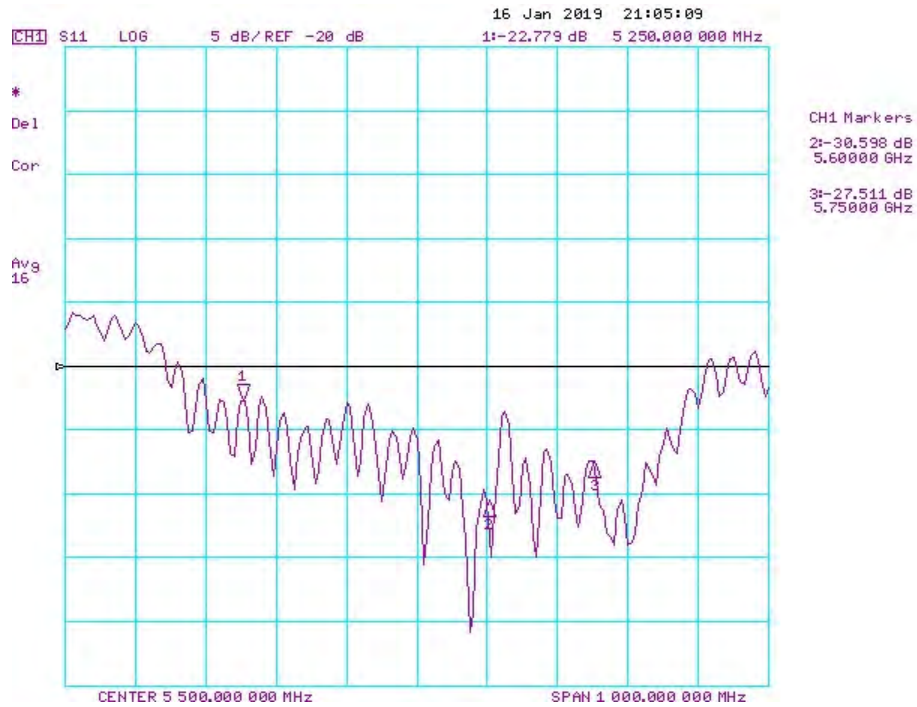
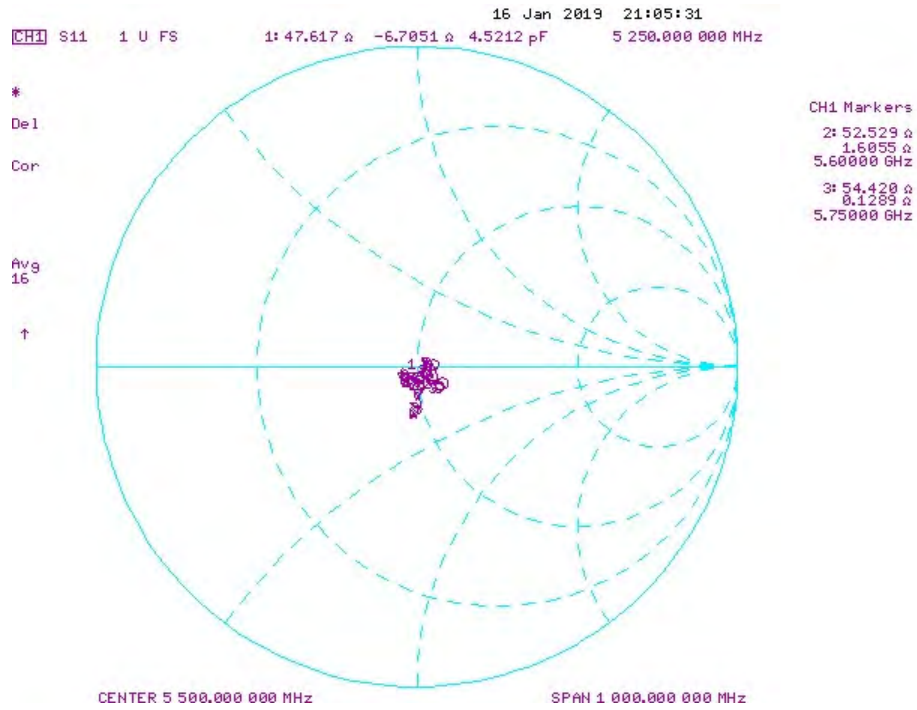

Impedance & Return-Loss Measurement Plot for Body TSL

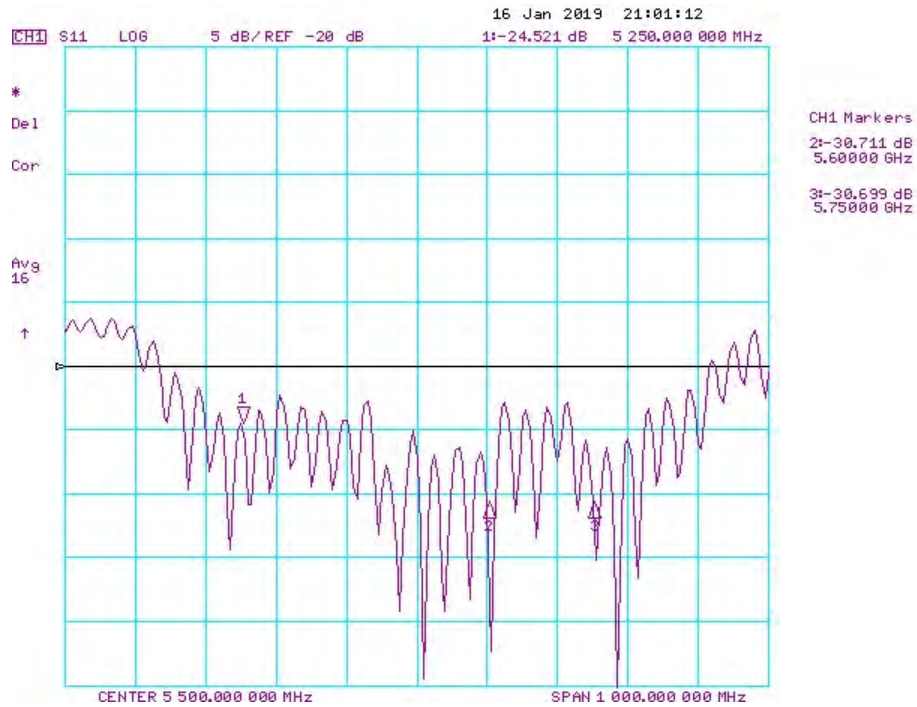
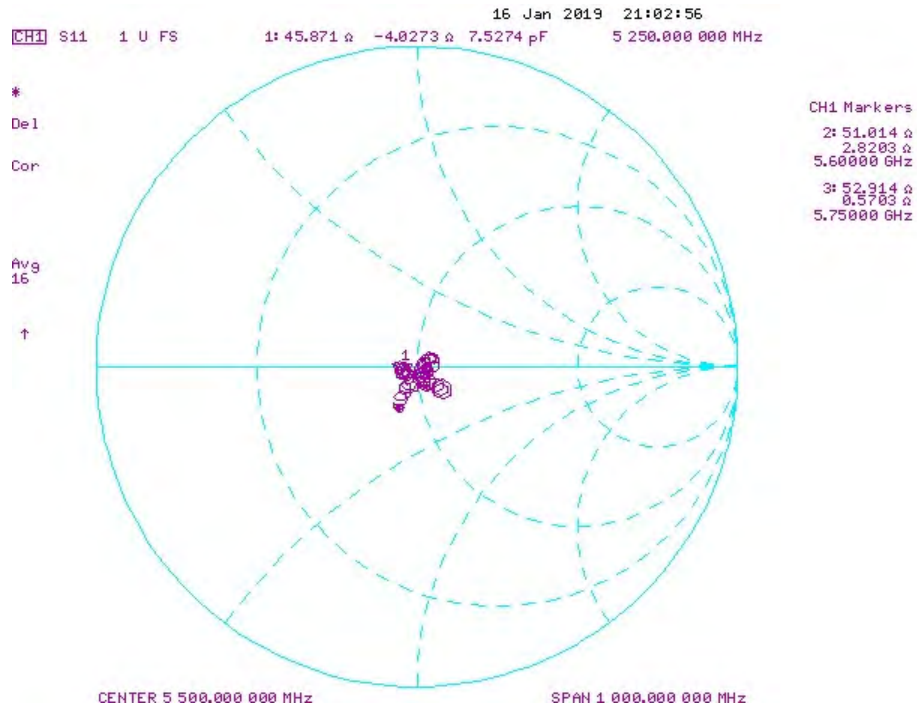



Accredited by the Swiss Accreditation Service (SAS)
The Swiss Accreditation Service is one of the signatories to the EA
Multilateral Agreement for the recognition of calibration certificates

Accreditation No.: **SCS 0108**

Client **PC Test**

Certificate No: **EX3-7357_Apr19**

CALIBRATION CERTIFICATE

Object **EX3DV4 - SN:7357**

Calibration procedure(s) **QA CAL-01.v9, QA CAL-12.v9, QA CAL-14.v5, QA CAL-23.v5,
QA CAL-25.v7
Calibration procedure for dosimetric E-field probes**

Calibration date: **April 24, 2019**

*BN ✓
4-29-2019*

This calibration certificate documents the traceability to national standards, which realize the physical units of measurements (SI).
The measurements and the uncertainties with confidence probability are given on the following pages and are part of the certificate.

All calibrations have been conducted in the closed laboratory facility: environment temperature (22 ± 3)°C and humidity < 70%.

Calibration Equipment used (M&TE critical for calibration)

Primary Standards	ID	Cal Date (Certificate No.)	Scheduled Calibration
Power meter NRP	SN: 104778	03-Apr-19 (No. 217-02892/02893)	Apr-20
Power sensor NRP-Z91	SN: 103244	03-Apr-19 (No. 217-02892)	Apr-20
Power sensor NRP-Z91	SN: 103245	03-Apr-19 (No. 217-02893)	Apr-20
Reference 20 dB Attenuator	SN: S5277 (20x)	04-Apr-19 (No. 217-02894)	Apr-20
DAE4	SN: 660	19-Dec-18 (No. DAE4-660_Dec18)	Dec-19
Reference Probe ES3DV2	SN: 3013	31-Dec-18 (No. ES3-3013_Dec18)	Dec-19
Secondary Standards	ID	Check Date (in house)	Scheduled Check
Power meter E4419B	SN: GB41293874	06-Apr-16 (in house check Jun-18)	In house check: Jun-20
Power sensor E4412A	SN: MY41498087	06-Apr-16 (in house check Jun-18)	In house check: Jun-20
Power sensor E4412A	SN: 000110210	06-Apr-16 (in house check Jun-18)	In house check: Jun-20
RF generator HP 8648C	SN: US3642U01700	04-Aug-99 (in house check Jun-18)	In house check: Jun-20
Network Analyzer E8358A	SN: US41080477	31-Mar-14 (in house check Oct-18)	In house check: Oct-19

Calibrated by: **Claudio Leubler** Name **Laboratory Technician** Function *[Signature]* Signature

Approved by: **Katja Pokovic** Technical Manager *[Signature]*

Issued: April 24, 2019

This calibration certificate shall not be reproduced except in full without written approval of the laboratory.



Accredited by the Swiss Accreditation Service (SAS)

Accreditation No.: **SCS 0108**

The Swiss Accreditation Service is one of the signatories to the EA Multilateral Agreement for the recognition of calibration certificates

Glossary:

TSL	tissue simulating liquid
NORM _{x,y,z}	sensitivity in free space
ConvF	sensitivity in TSL / NORM _{x,y,z}
DCP	diode compression point
CF	crest factor (1/duty_cycle) of the RF signal
A, B, C, D	modulation dependent linearization parameters
Polarization φ	φ rotation around probe axis
Polarization ϑ	ϑ rotation around an axis that is in the plane normal to probe axis (at measurement center), i.e., ϑ = 0 is normal to probe axis
Connector Angle	information used in DASY system to align probe sensor X to the robot coordinate system

Calibration is Performed According to the Following Standards:

- a) IEEE Std 1528-2013, "IEEE Recommended Practice for Determining the Peak Spatial-Averaged Specific Absorption Rate (SAR) in the Human Head from Wireless Communications Devices: Measurement Techniques", June 2013
- b) IEC 62209-1, "Measurement procedure for the assessment of Specific Absorption Rate (SAR) from hand-held and body-mounted devices used next to the ear (frequency range of 300 MHz to 6 GHz)", July 2016
- c) IEC 62209-2, "Procedure to determine the Specific Absorption Rate (SAR) for wireless communication devices used in close proximity to the human body (frequency range of 30 MHz to 6 GHz)", March 2010
- d) KDB 865664, "SAR Measurement Requirements for 100 MHz to 6 GHz"

Methods Applied and Interpretation of Parameters:

- *NORM_{x,y,z}*: Assessed for E-field polarization ϑ = 0 (f ≤ 900 MHz in TEM-cell; f > 1800 MHz: R22 waveguide). *NORM_{x,y,z}* are only intermediate values, i.e., the uncertainties of *NORM_{x,y,z}* does not affect the E²-field uncertainty inside TSL (see below *ConvF*).
- *NORM(f)_{x,y,z}* = *NORM_{x,y,z}* * *frequency_response* (see Frequency Response Chart). This linearization is implemented in DASY4 software versions later than 4.2. The uncertainty of the frequency response is included in the stated uncertainty of *ConvF*.
- *DCP_{x,y,z}*: DCP are numerical linearization parameters assessed based on the data of power sweep with CW signal (no uncertainty required). DCP does not depend on frequency nor media.
- *PAR*: PAR is the Peak to Average Ratio that is not calibrated but determined based on the signal characteristics
- *A_{x,y,z}*; *B_{x,y,z}*; *C_{x,y,z}*; *D_{x,y,z}*; *VR_{x,y,z}*: *A, B, C, D* are numerical linearization parameters assessed based on the data of power sweep for specific modulation signal. The parameters do not depend on frequency nor media. *VR* is the maximum calibration range expressed in RMS voltage across the diode.
- *ConvF and Boundary Effect Parameters*: Assessed in flat phantom using E-field (or Temperature Transfer Standard for f ≤ 800 MHz) and inside waveguide using analytical field distributions based on power measurements for f > 800 MHz. The same setups are used for assessment of the parameters applied for boundary compensation (alpha, depth) of which typical uncertainty values are given. These parameters are used in DASY4 software to improve probe accuracy close to the boundary. The sensitivity in TSL corresponds to *NORM_{x,y,z}* * *ConvF* whereby the uncertainty corresponds to that given for *ConvF*. A frequency dependent *ConvF* is used in DASY version 4.4 and higher which allows extending the validity from ± 50 MHz to ± 100 MHz.
- *Spherical isotropy (3D deviation from isotropy)*: in a field of low gradients realized using a flat phantom exposed by a patch antenna.
- *Sensor Offset*: The sensor offset corresponds to the offset of virtual measurement center from the probe tip (on probe axis). No tolerance required.
- *Connector Angle*: The angle is assessed using the information gained by determining the *NORM_x* (no uncertainty required).

DASY/EASY - Parameters of Probe: EX3DV4 - SN:7357

Basic Calibration Parameters

	Sensor X	Sensor Y	Sensor Z	Unc (k=2)
Norm ($\mu\text{V}/(\text{V}/\text{m})^2$) ^A	0.37	0.48	0.41	$\pm 10.1 \%$
DCP (mV) ^B	87.5	101.0	95.2	

Calibration Results for Modulation Response

UID	Communication System Name		A dB	B dB $\sqrt{\mu\text{V}}$	C	D dB	VR mV	Max dev.	Max Unc ^E (k=2)
0	CW	X	0.00	0.00	1.00	0.00	175.5	$\pm 2.7 \%$	$\pm 4.7 \%$
		Y	0.00	0.00	1.00		162.7		
		Z	0.00	0.00	1.00		160.1		
10352- AAA	Pulse Waveform (200Hz, 10%)	X	1.63	60.99	8.59	10.00	60.0	$\pm 3.2 \%$	$\pm 9.6 \%$
		Y	15.00	88.78	20.10		60.0		
		Z	1.92	62.77	9.39		60.0		
10353- AAA	Pulse Waveform (200Hz, 20%)	X	1.28	62.05	7.66	6.99	80.0	$\pm 2.1 \%$	$\pm 9.6 \%$
		Y	15.00	92.12	20.60		80.0		
		Z	1.44	63.37	8.24		80.0		
10354- AAA	Pulse Waveform (200Hz, 40%)	X	0.53	60.00	5.08	3.98	95.0	$\pm 1.2 \%$	$\pm 9.6 \%$
		Y	15.00	98.74	22.38		95.0		
		Z	0.50	60.00	4.96		95.0		
10355- AAA	Pulse Waveform (200Hz, 60%)	X	0.34	60.00	3.46	2.22	120.0	$\pm 1.3 \%$	$\pm 9.6 \%$
		Y	15.00	122.09	31.59		120.0		
		Z	0.32	60.00	3.17		120.0		
10387- AAA	QPSK Waveform, 1 MHz	X	0.47	60.00	5.85	0.00	150.0	$\pm 3.4 \%$	$\pm 9.6 \%$
		Y	0.84	63.60	10.73		150.0		
		Z	0.47	60.00	5.64		150.0		
10388- AAA	QPSK Waveform, 10 MHz	X	2.22	69.17	16.45	0.00	150.0	$\pm 1.2 \%$	$\pm 9.6 \%$
		Y	2.39	69.28	16.48		150.0		
		Z	2.05	67.86	15.44		150.0		
10396- AAA	64-QAM Waveform, 100 kHz	X	1.74	66.32	18.65	3.01	150.0	$\pm 6.4 \%$	$\pm 9.6 \%$
		Y	3.21	72.13	19.45		150.0		
		Z	2.50	68.64	18.00		150.0		
10399- AAA	64-QAM Waveform, 40 MHz	X	3.50	67.46	16.21	0.00	150.0	$\pm 2.5 \%$	$\pm 9.6 \%$
		Y	3.59	67.57	16.11		150.0		
		Z	3.40	67.11	15.75		150.0		
10414- AAA	WLAN CCDF, 64-QAM, 40MHz	X	4.79	65.80	15.93	0.00	150.0	$\pm 4.6 \%$	$\pm 9.6 \%$
		Y	4.92	65.80	15.71		150.0		
		Z	4.73	65.72	15.66		150.0		

Note: For details on UID parameters see Appendix

The reported uncertainty of measurement is stated as the standard uncertainty of measurement multiplied by the coverage factor k=2, which for a normal distribution corresponds to a coverage probability of approximately 95%.

^A The uncertainties of Norm X,Y,Z do not affect the E²-field uncertainty inside TSL (see Pages 5 and 6).

^B Numerical linearization parameter: uncertainty not required.

^E Uncertainty is determined using the max. deviation from linear response applying rectangular distribution and is expressed for the square of the field value.

DASY/EASY - Parameters of Probe: EX3DV4 - SN:7357

Sensor Model Parameters

	C1 fF	C2 fF	α V ⁻¹	T1 ms.V ⁻²	T2 ms.V ⁻¹	T3 ms	T4 V ⁻²	T5 V ⁻¹	T6
X	37.3	299.85	40.64	5.98	0.77	5.00	0.00	0.00	1.02
Y	48.9	366.83	35.90	10.43	0.11	5.09	1.58	0.24	1.01
Z	37.8	294.77	38.42	5.12	0.55	5.04	0.00	0.43	1.01

Other Probe Parameters

Sensor Arrangement	Triangular
Connector Angle (°)	14.2
Mechanical Surface Detection Mode	enabled
Optical Surface Detection Mode	disabled
Probe Overall Length	337 mm
Probe Body Diameter	10 mm
Tip Length	9 mm
Tip Diameter	2.5 mm
Probe Tip to Sensor X Calibration Point	1 mm
Probe Tip to Sensor Y Calibration Point	1 mm
Probe Tip to Sensor Z Calibration Point	1 mm
Recommended Measurement Distance from Surface	1.4 mm

DASY/EASY - Parameters of Probe: EX3DV4 - SN:7357

Calibration Parameter Determined in Head Tissue Simulating Media

f (MHz) ^C	Relative Permittivity ^F	Conductivity (S/m) ^F	ConvF X	ConvF Y	ConvF Z	Alpha ^G	Depth ^G (mm)	Unc (k=2)
64	54.2	0.75	14.77	14.77	14.77	0.00	1.00	± 13.3 %
750	41.9	0.89	10.26	10.26	10.26	0.45	0.95	± 12.0 %
835	41.5	0.90	9.91	9.91	9.91	0.53	0.85	± 12.0 %
1750	40.1	1.37	8.69	8.69	8.69	0.35	0.80	± 12.0 %
1900	40.0	1.40	8.26	8.26	8.26	0.33	0.84	± 12.0 %
2300	39.5	1.67	7.70	7.70	7.70	0.33	0.85	± 12.0 %
2450	39.2	1.80	7.57	7.57	7.57	0.39	0.85	± 12.0 %
2600	39.0	1.96	7.31	7.31	7.31	0.40	0.80	± 12.0 %
5250	35.9	4.71	5.45	5.45	5.45	0.40	1.80	± 13.1 %
5600	35.5	5.07	4.85	4.85	4.85	0.40	1.80	± 13.1 %
5750	35.4	5.22	5.06	5.06	5.06	0.40	1.80	± 13.1 %

^C Frequency validity above 300 MHz of ± 100 MHz only applies for DASY v4.4 and higher (see Page 2), else it is restricted to ± 50 MHz. The uncertainty is the RSS of the ConvF uncertainty at calibration frequency and the uncertainty for the indicated frequency band. Frequency validity below 300 MHz is ± 10, 25, 40, 50 and 70 MHz for ConvF assessments at 30, 64, 128, 150 and 220 MHz respectively. Validity of ConvF assessed at 6 MHz is 4-9 MHz, and ConvF assessed at 13 MHz is 9-19 MHz. Above 5 GHz frequency validity can be extended to ± 110 MHz.

^F At frequencies below 3 GHz, the validity of tissue parameters (ϵ and σ) can be relaxed to ± 10% if liquid compensation formula is applied to measured SAR values. At frequencies above 3 GHz, the validity of tissue parameters (ϵ and σ) is restricted to ± 5%. The uncertainty is the RSS of the ConvF uncertainty for indicated target tissue parameters.

^G Alpha/Depth are determined during calibration. SPEAG warrants that the remaining deviation due to the boundary effect after compensation is always less than ± 1% for frequencies below 3 GHz and below ± 2% for frequencies between 3-6 GHz at any distance larger than half the probe tip diameter from the boundary.

DASY/EASY - Parameters of Probe: EX3DV4 - SN:7357

Calibration Parameter Determined in Body Tissue Simulating Media

f (MHz) ^C	Relative Permittivity ^F	Conductivity (S/m) ^F	ConvF X	ConvF Y	ConvF Z	Alpha ^G	Depth ^G (mm)	Unc (k=2)
750	55.5	0.96	10.19	10.19	10.19	0.37	0.96	± 12.0 %
835	55.2	0.97	9.95	9.95	9.95	0.47	0.80	± 12.0 %
1750	53.4	1.49	8.26	8.26	8.26	0.35	0.85	± 12.0 %
1900	53.3	1.52	7.93	7.93	7.93	0.32	0.90	± 12.0 %
2300	52.9	1.81	7.72	7.72	7.72	0.30	0.85	± 12.0 %
2450	52.7	1.95	7.59	7.59	7.59	0.35	0.86	± 12.0 %
2600	52.5	2.16	7.39	7.39	7.39	0.32	0.89	± 12.0 %
5250	48.9	5.36	4.61	4.61	4.61	0.50	1.90	± 13.1 %
5600	48.5	5.77	4.03	4.03	4.03	0.50	1.90	± 13.1 %
5750	48.3	5.94	4.15	4.15	4.15	0.50	1.90	± 13.1 %

^C Frequency validity above 300 MHz of ± 100 MHz only applies for DASY v4.4 and higher (see Page 2), else it is restricted to ± 50 MHz. The uncertainty is the RSS of the ConvF uncertainty at calibration frequency and the uncertainty for the indicated frequency band. Frequency validity below 300 MHz is ± 10, 25, 40, 50 and 70 MHz for ConvF assessments at 30, 64, 128, 150 and 220 MHz respectively. Validity of ConvF assessed at 6 MHz is 4-9 MHz, and ConvF assessed at 13 MHz is 9-19 MHz. Above 5 GHz frequency validity can be extended to ± 110 MHz.

^F At frequencies below 3 GHz, the validity of tissue parameters (ϵ and σ) can be relaxed to ± 10% if liquid compensation formula is applied to measured SAR values. At frequencies above 3 GHz, the validity of tissue parameters (ϵ and σ) is restricted to ± 5%. The uncertainty is the RSS of the ConvF uncertainty for indicated target tissue parameters.

^G Alpha/Depth are determined during calibration. SPEAG warrants that the remaining deviation due to the boundary effect after compensation is always less than ± 1% for frequencies below 3 GHz and below ± 2% for frequencies between 3-6 GHz at any distance larger than half the probe tip diameter from the boundary.

Frequency Response of E-Field (TEM-Cell:ifi110 EXX, Waveguide: R22)

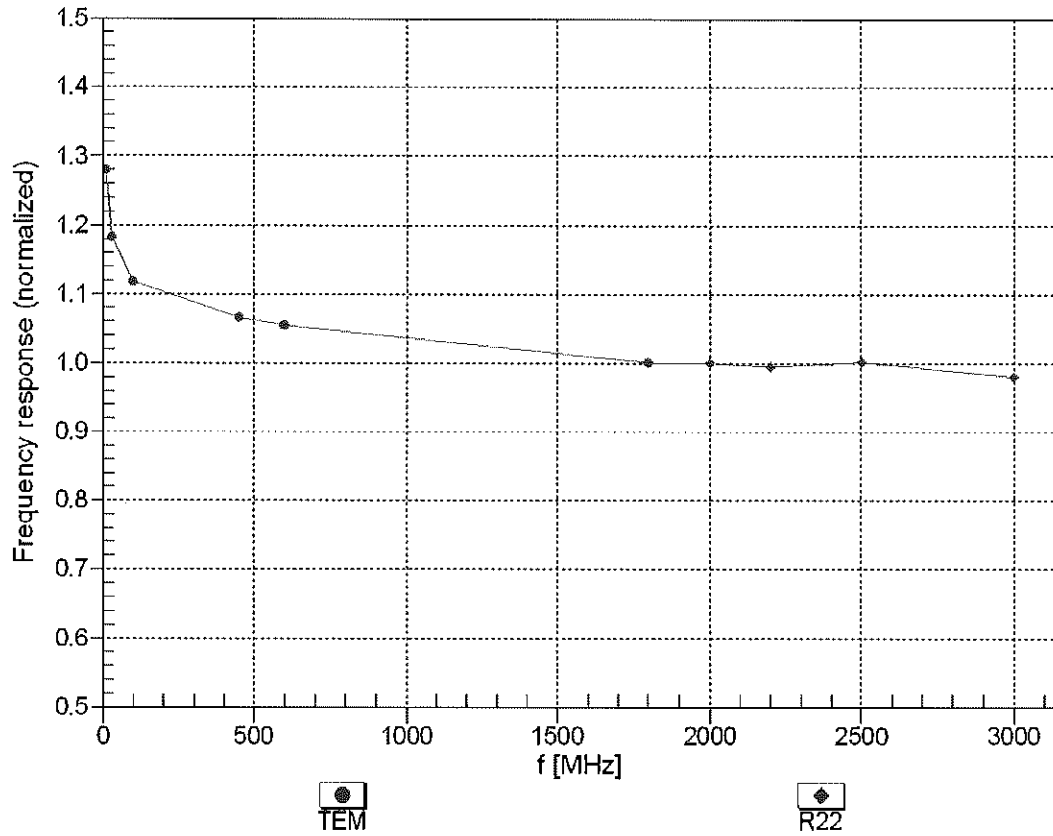

Uncertainty of Frequency Response of E-field: $\pm 6.3\%$ ($k=2$)

Receiving Pattern (ϕ), $\vartheta = 0^\circ$

f=600 MHz,TEM

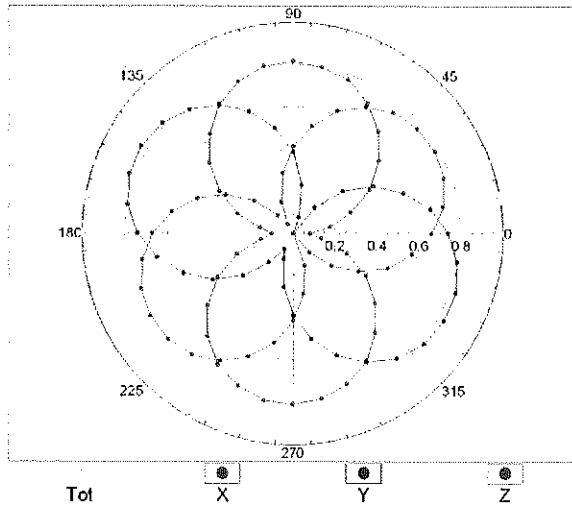

f=1800 MHz,R22

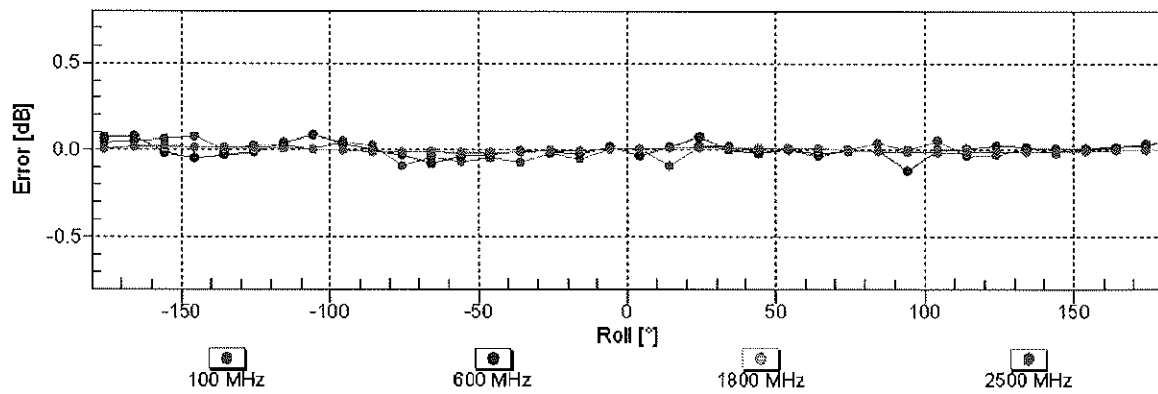
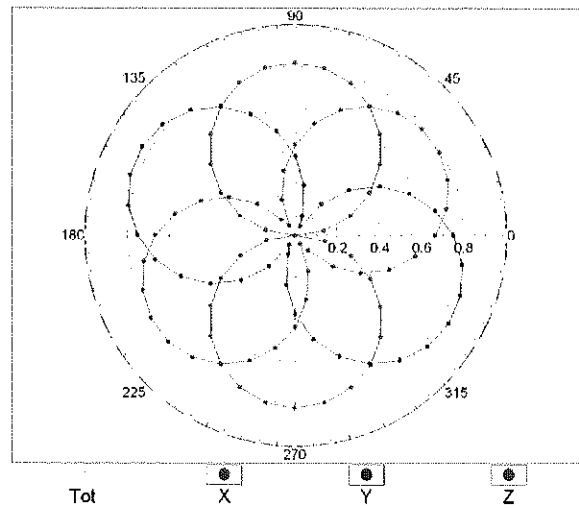

Uncertainty of Axial Isotropy Assessment: $\pm 0.5\%$ ($k=2$)