

HIGH CHANNEL HORIZONTAL

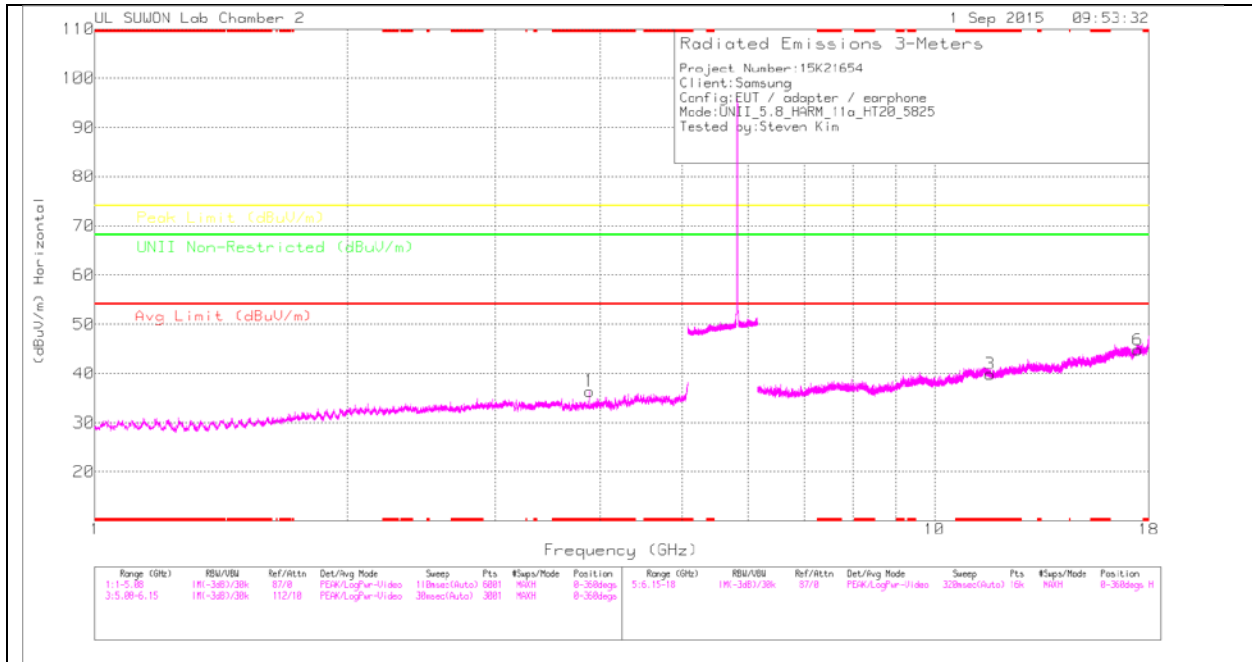

HIGH CHANNEL VERTICAL

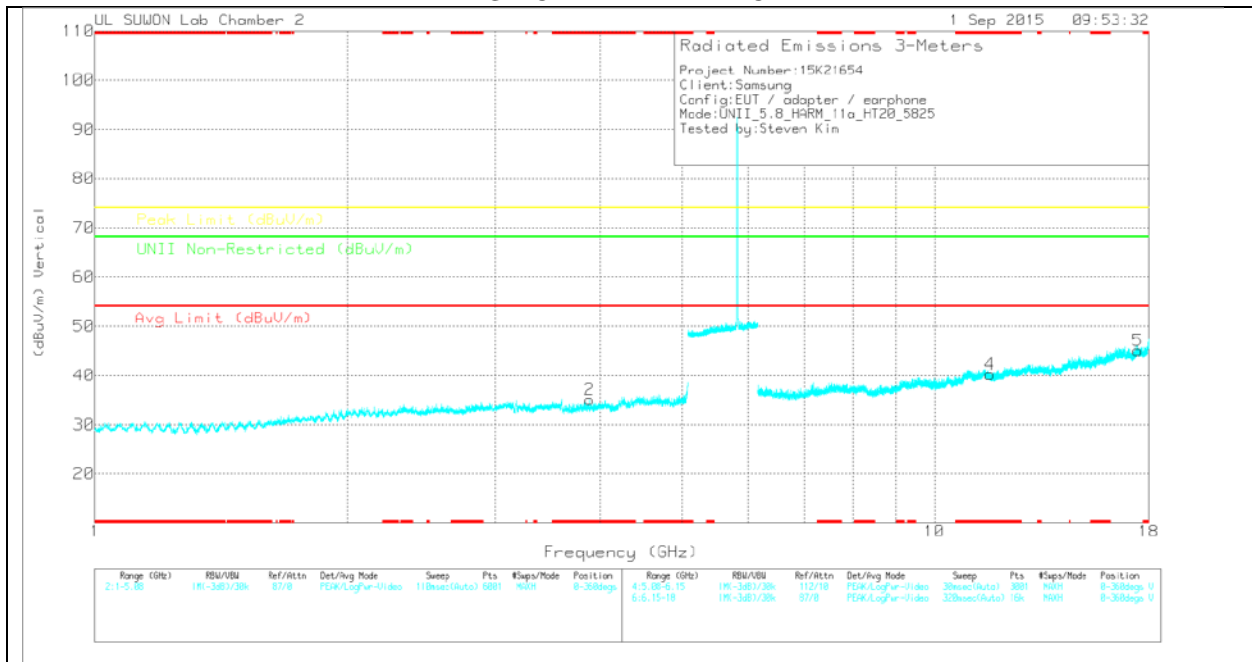

Note: Emission was scanned up to 40GHz; No emissions were detected above the noise floor which was at least 20dB below the specification limit.

HIGH CHANNEL DATA

TRACE MARKERS

Marker	Frequency (GHz)	Meter Reading (dBuV)	Det	3117(001687 8724)_150 619	Path_4	DC Corr (dB)	Corrected Reading (dBuV/m)	Avg Limit (dBuV/m)	Margin (dB)	Peak Limit (dBuV/m)	Margin (dB)	UNII Non-Restricted (dBuV/m)	Margin (dB)	Azimuth (Degs)	Height (cm)	Polarity
1	* 3.884	28.81	PK	33.1	-25.5	0	36.41	-	-	74	-37.59	-	-	0-360	200	H
2	* 3.883	27.47	PK	33.1	-25.5	0	35.07	-	-	74	-38.93	-	-	0-360	200	V
3	* 11.649	18.87	PK	38.4	-17.4	0	39.87	-	-	74	-34.13	-	-	0-360	100	H
6	17.475	17.97	PK	41.3	-14.5	0	44.77	-	-	-	-	68.2	-23.43	0-360	200	H
4	* 11.651	19.23	PK	38.4	-17.4	0	40.23	-	-	74	-33.77	-	-	0-360	100	V
5	17.476	18.22	PK	41.3	-14.5	0	45.02	-	-	-	-	68.2	-23.18	0-360	200	V

* - indicates frequency in CFR15.205/IC7.2.2 Restricted Band

PK – Peak detector

Radiated Emissions

Frequency (GHz)	Meter Reading (dBuV)	Det	3117(001687 24)_150619	Path_4	DC Corr (dB)	Corrected Reading (dBuV/m)	Avg Limit (dBuV/m)	Margin (dB)	Peak Limit (dBuV/m)	Margin (dB)	UNII Non-Restricted (dBuV/m)	Margin (dB)	Azimuth (Degs)	Height (cm)	Polarity
* 3.883	38.02	PK-U	33.1	-25.5	0	45.62	-	-	74	-28.38	-	-	260	392	H
* 3.883	28.9	ADR	33.1	-25.5	0	36.5	54	-17.5	-	-	-	-	260	392	H
* 3.883	37.79	PK-U	33.1	-25.5	0	45.39	-	-	74	-28.61	-	-	191	320	V
* 3.883	26.95	ADR	33.1	-25.5	0	34.55	54	-19.45	-	-	-	-	191	320	V

* - indicates frequency in CFR15.205/IC7.2.2 Restricted Band

PK-U - U-NII: Maximum Peak

ADR - U-NII AD primary method, RMS average

11.4.2. TX ABOVE 1 GHz 802.11n HT20 MODE IN THE 5.8 GHz BAND HARMONICS AND SPURIOUS EMISSIONS HORIZONTAL PEAK PLOT

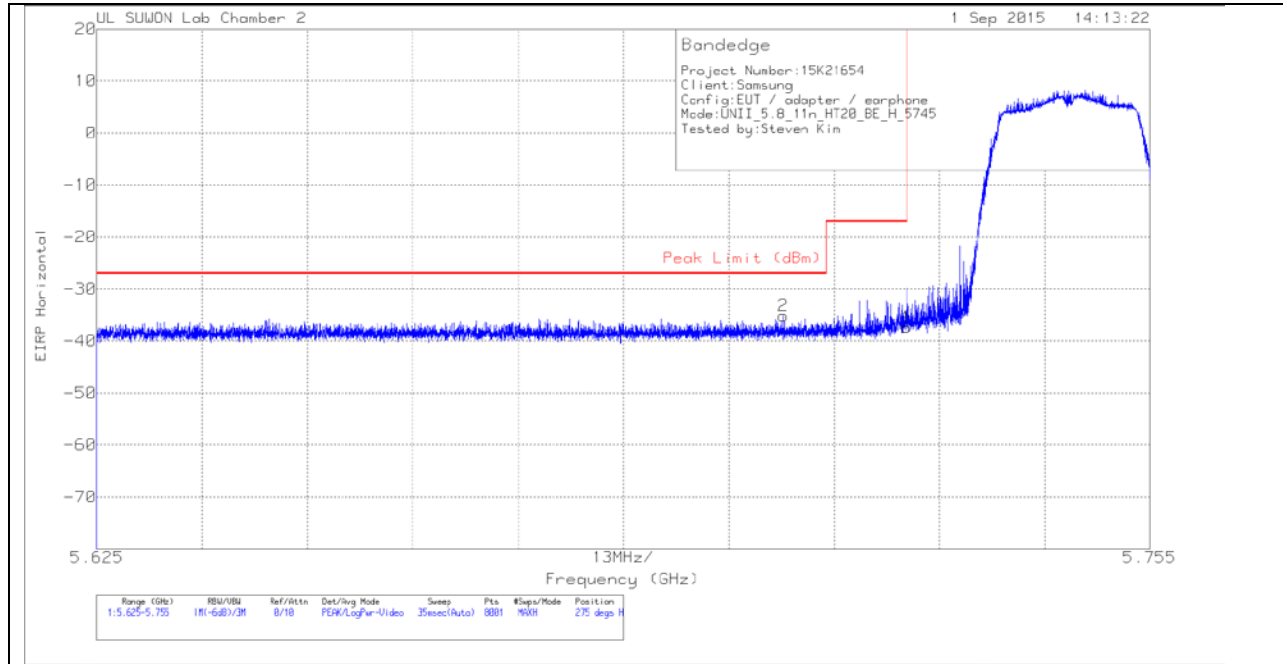

HORIZONTAL DATA

TRACE MARKERS

Marker	Frequency (GHz)	Meter Reading (dBm)	Det	3117(0016 8724)_150 619	Path_2_10 dB	Conversion Factor (dB)	DC Corr (dB)	Corrected Reading EIRP	Peak Limit (dBm)	PK Margin (dB)	Azimuth (Degs)	Height (cm)	Polarity
1	5.725	-68.22	Pk	34.7	-15.6	11.8	0	-37.32	-17	-20.32	275	328	H
2	5.71	-66.04	Pk	34.7	-15.6	11.8	0	-35.14	-27	-8.14	275	328	H

Pk - Peak detector

VERTICAL PEAK PLOT

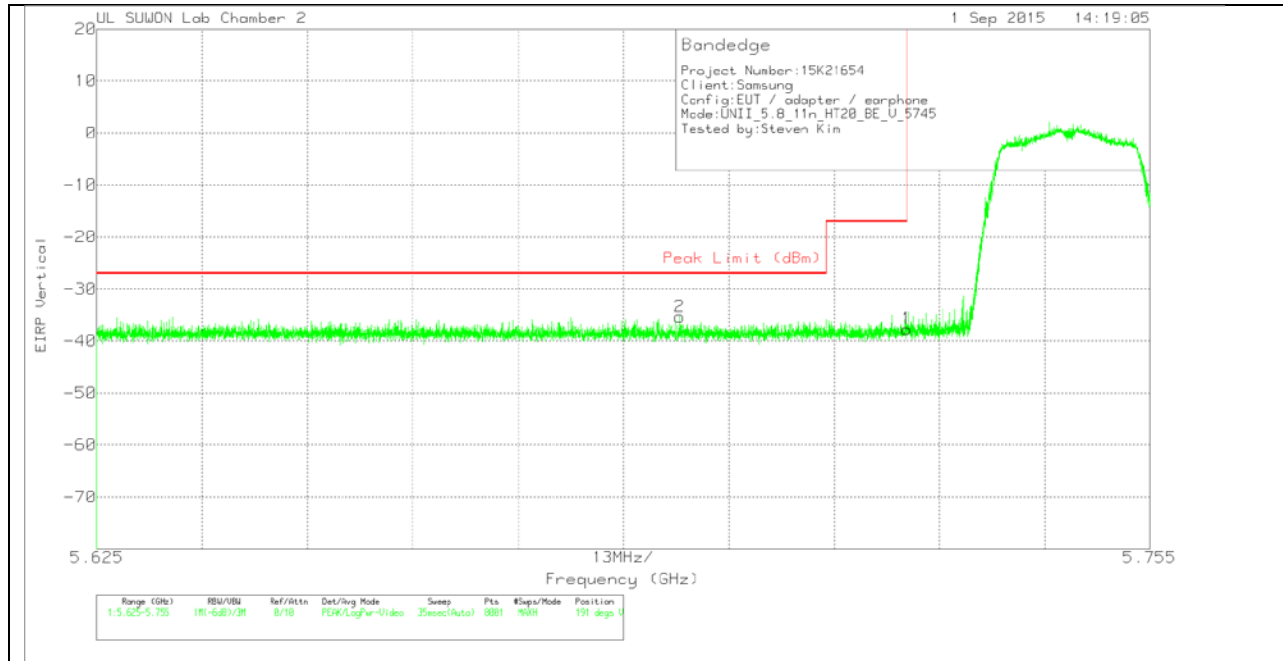

VERTICAL DATA

TRACE MARKERS

Marker	Frequency (GHz)	Meter Reading (dBm)	Det	3117(0016 8724)_150 619	Path_2_10 dB	Conversion Factor (dB)	DC Corr (dB)	Corrected Reading EIRP	Peak Limit (dBm)	PK Margin (dB)	Azimuth (Degs)	Height (cm)	Polarity
1	5.725	-68.55	Pk	34.7	-15.6	11.8	0	-37.65	-17	-20.65	191	117	V
2	5.697	-66.23	Pk	34.7	-15.6	11.8	0	-35.33	-27	-8.33	191	117	V

Pk - Peak detector

AUTHORIZED BANDEDGE (HIGH CHANNEL)

HORIZONTAL PEAK AND AVERAGE PLOT

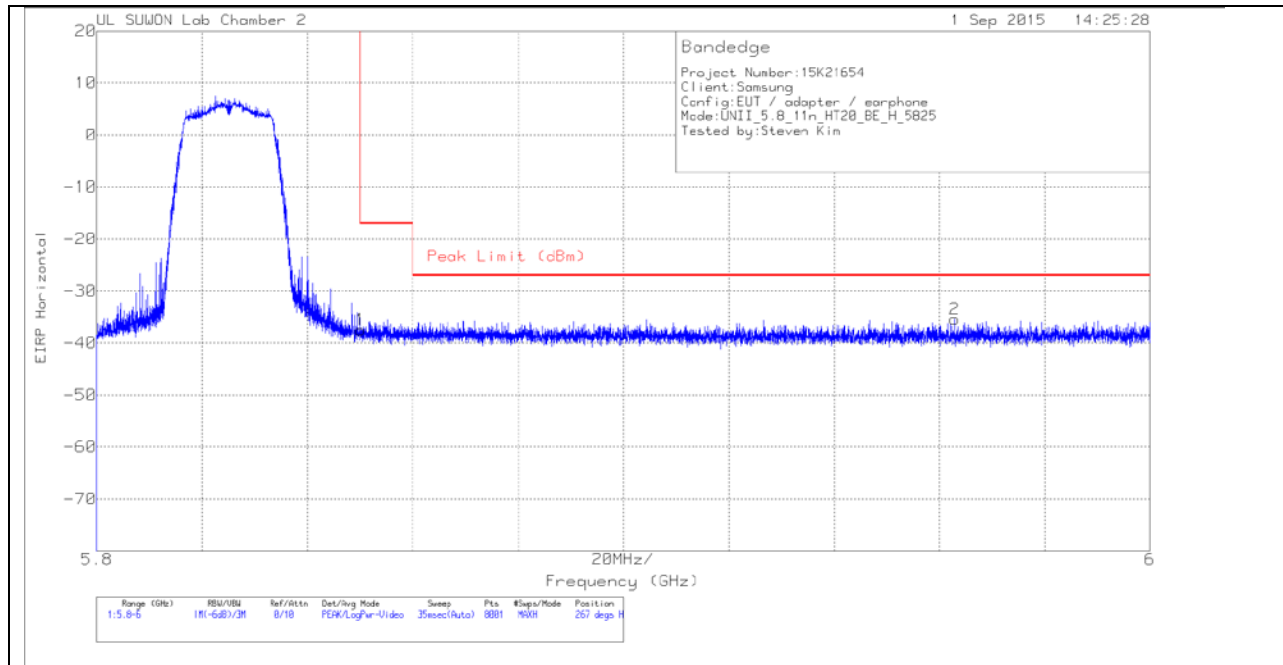

HORIZONTAL DATA

TRACE MARKERS

Marker	Frequency (GHz)	Meter Reading (dBm)	Det	3117(0016 8724)_150 619	Path_2_10 dB	Conversion Factor (dB)	DC Corr (dB)	Corrected Reading EIRP	Peak Limit (dBm)	PK Margin (dB)	Azimuth (Degs)	Height (cm)	Polarity
1	5.85	-68.49	Pk	34.7	-15.5	11.8	0	-37.49	-17	-20.49	267	351	H
2	5.963	-66.61	Pk	34.8	-15.4	11.8	0	-35.41	-27	-8.41	267	351	H

Pk - Peak detector

VERTICAL PEAK PLOT

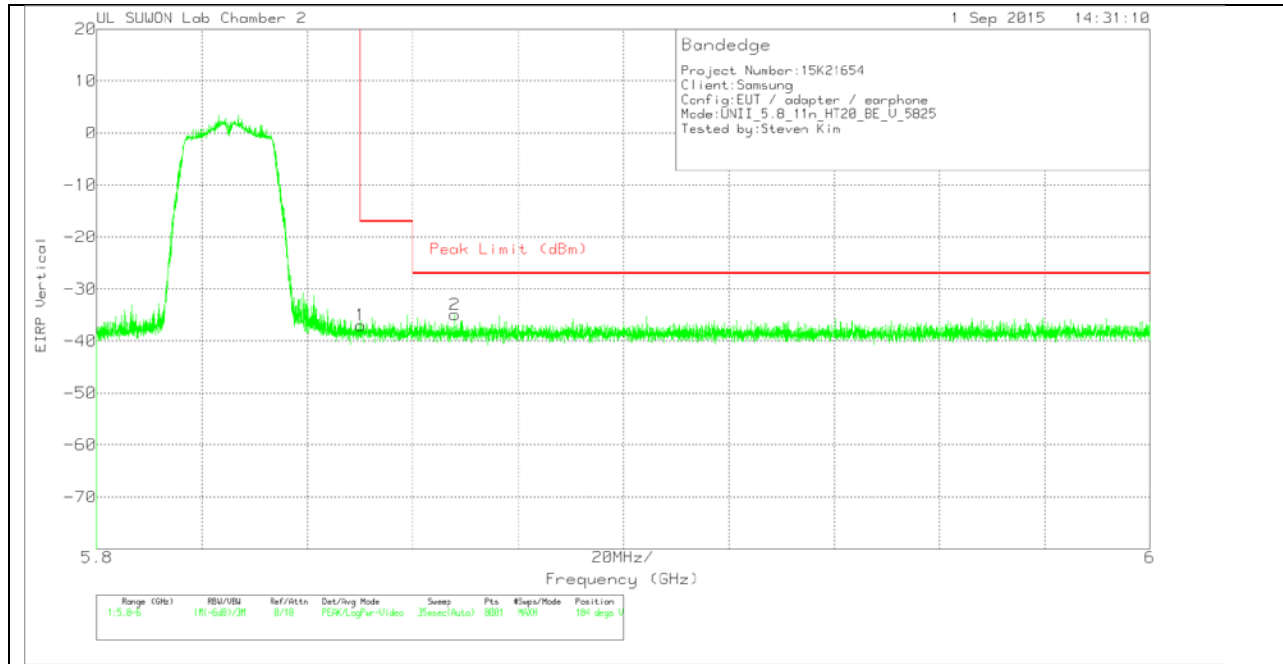

VERTICAL DATA

TRACE MARKERS

Marker	Frequency (GHz)	Meter Reading (dBm)	Det	3117(0016 8724)_150 619	Path_2_10 dB	Conversion Factor (dB)	DC Corr (dB)	Corrected Reading EIRP	Peak Limit (dBm)	PK Margin (dB)	Azimuth (Degs)	Height (cm)	Polarity
1	5.85	-67.96	Pk	34.7	-15.5	11.8	0	-36.96	-17	-19.96	184	366	V
2	5.868	-65.93	Pk	34.7	-15.5	11.8	0	-34.93	-27	-7.93	184	366	V

Pk - Peak detector

LOW CHANNEL HORIZONTAL

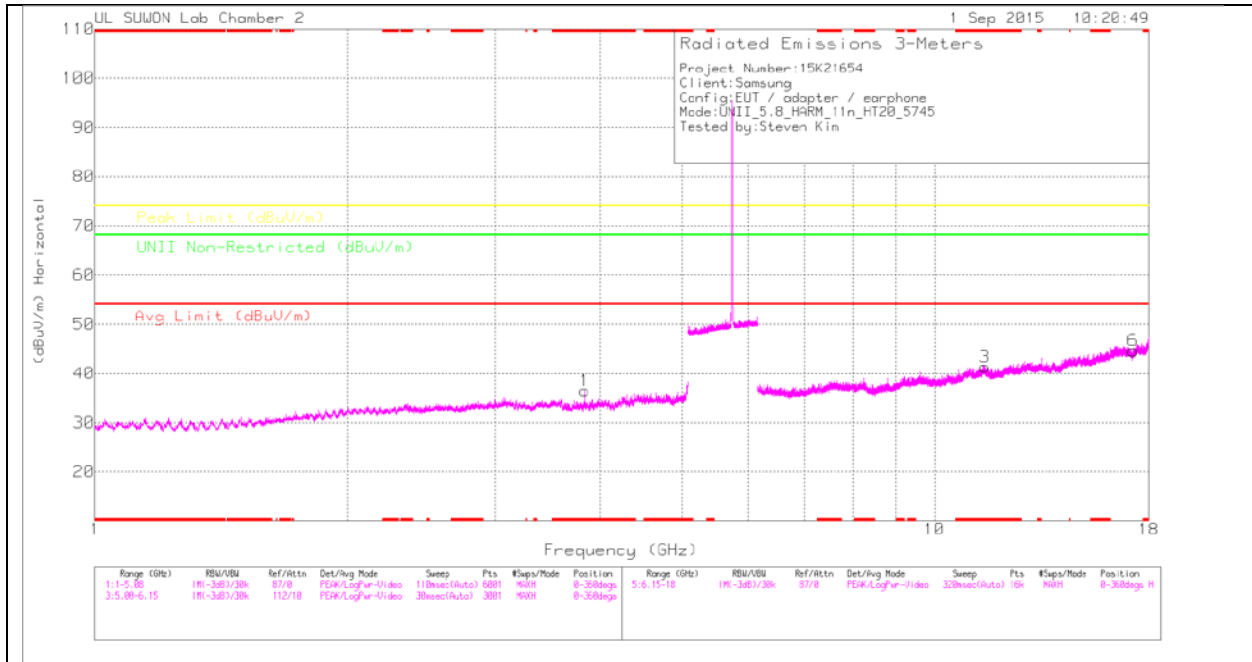

LOW CHANNEL VERTICAL

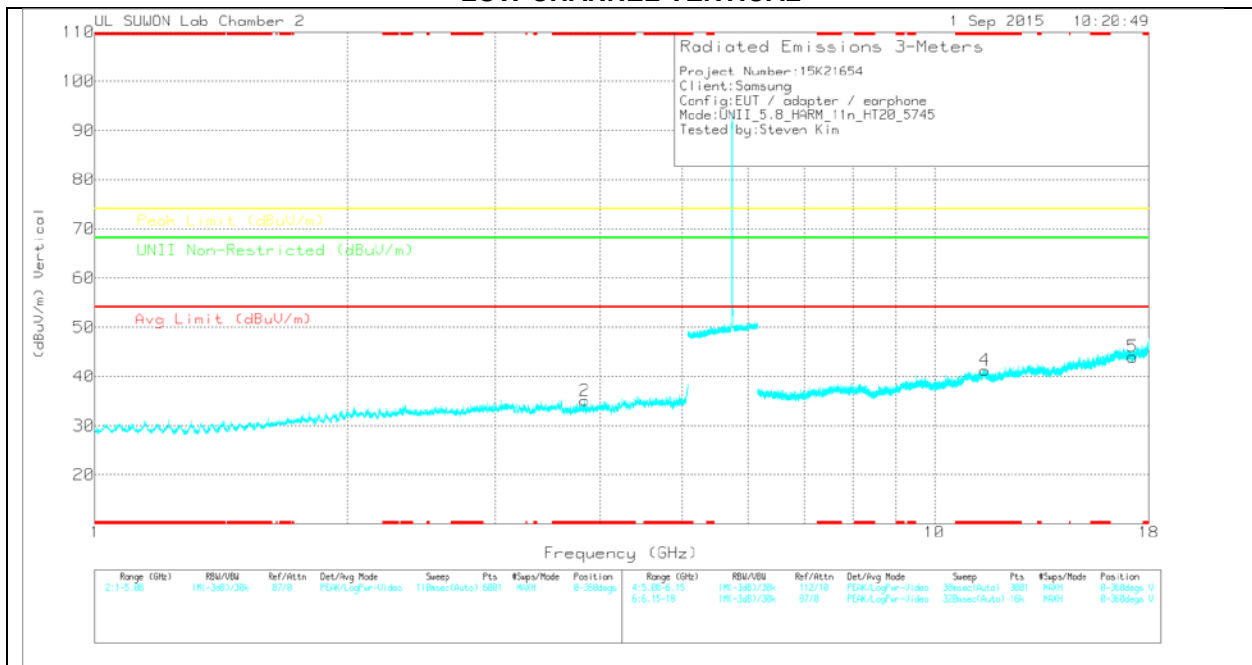

Note: Emission was scanned up to 40GHz; No emissions were detected above the noise floor which was at least 20dB below the specification limit.

LOW CHANNEL DATA

TRACE MARKERS

Marker	Frequency (GHz)	Meter Reading (dBuV)	Det	3117(0016 8724)_150 619	Path_4	DC Corr (dB)	Corrected Reading (dBuV/m)	Avg Limit (dBuV/m)	Margin (dB)	Peak Limit (dBuV/m)	Margin (dB)	UNII Non-Restricted (dBuV/m)	Margin (dB)	Azimuth (Degs)	Height (cm)	Polarity
1	* 3.83	29.09	PK	33.1	-25.7	0	36.49	-	-	74	-37.51	-	-	0-360	200	H
2	* 3.83	27.68	PK	33.1	-25.7	0	35.08	-	-	74	-38.92	-	-	0-360	200	V
3	* 11.482	20.51	PK	38.3	-17.5	0	41.31	-	-	74	-32.69	-	-	0-360	200	H
6	17.243	18.62	PK	41.2	-15.2	0	44.62	-	-	-	-	68.2	-23.58	0-360	100	H
4	* 11.481	20.47	PK	38.3	-17.5	0	41.27	-	-	74	-32.73	-	-	0-360	200	V
5	17.236	17.98	PK	41.2	-15.2	0	43.98	-	-	-	-	68.2	-24.22	0-360	100	V

* - indicates frequency in CFR15.205/IC7.2.2 Restricted Band

PK – Peak detector

Radiated Emissions

Frequency (GHz)	Meter Reading (dBuV)	Det	3117(0016872 4)_150619	Path_4	DC Corr (dB)	Corrected Reading (dBuV/m)	Avg Limit (dBuV/m)	Margin (dB)	Peak Limit (dBuV/m)	Margin (dB)	UNII Non-Restricted (dBuV/m)	Margin (dB)	Azimuth (Degs)	Height (cm)	Polarity
* 3.83	37.63	PK-U	33.1	-25.7	0	45.03	-	-	74	-28.97	-	-	251	299	H
* 3.83	27.4	ADR	33.1	-25.7	0	34.8	54	-19.2	-	-	-	-	251	299	H
* 3.835	37.15	PK-U	33.1	-25.6	0	44.65	-	-	74	-29.35	-	-	292	147	V
* 3.827	23.6	ADR	33.1	-25.7	0	31	54	-23	-	-	-	-	292	147	V

* - indicates frequency in CFR15.205/IC7.2.2 Restricted Band

PK-U - U-NII: Maximum Peak

ADR - U-NII AD primary method, RMS average

MID CHANNEL HORIZONTAL

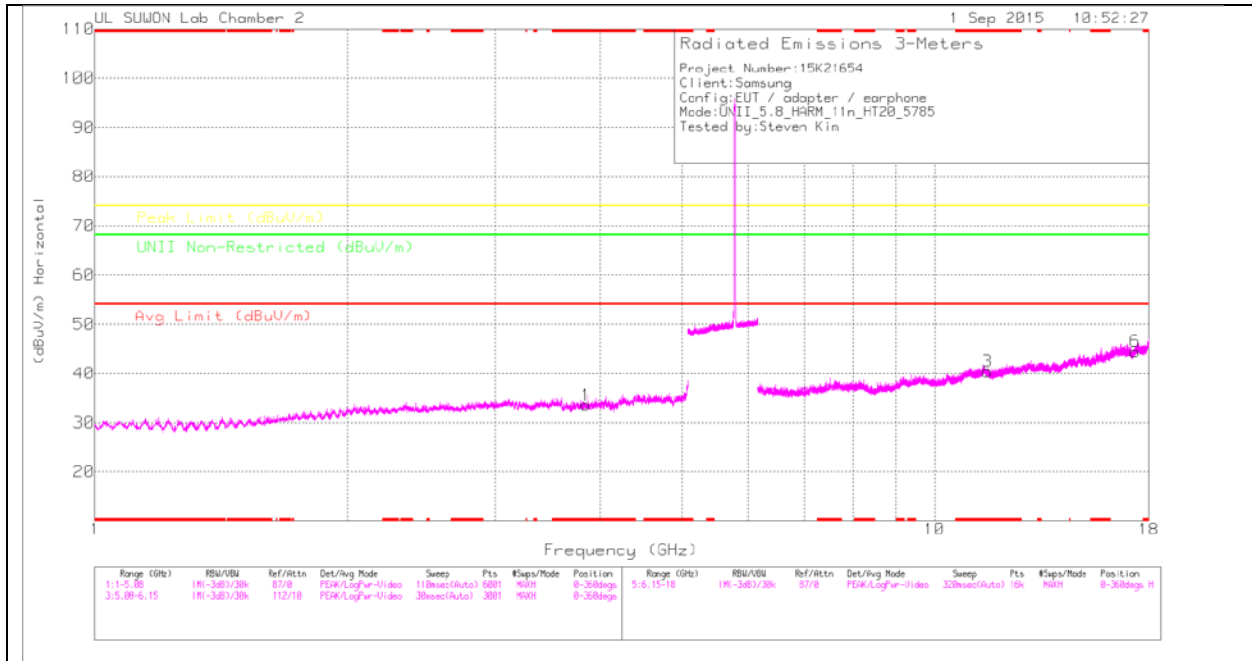

MID CHANNEL VERTICAL

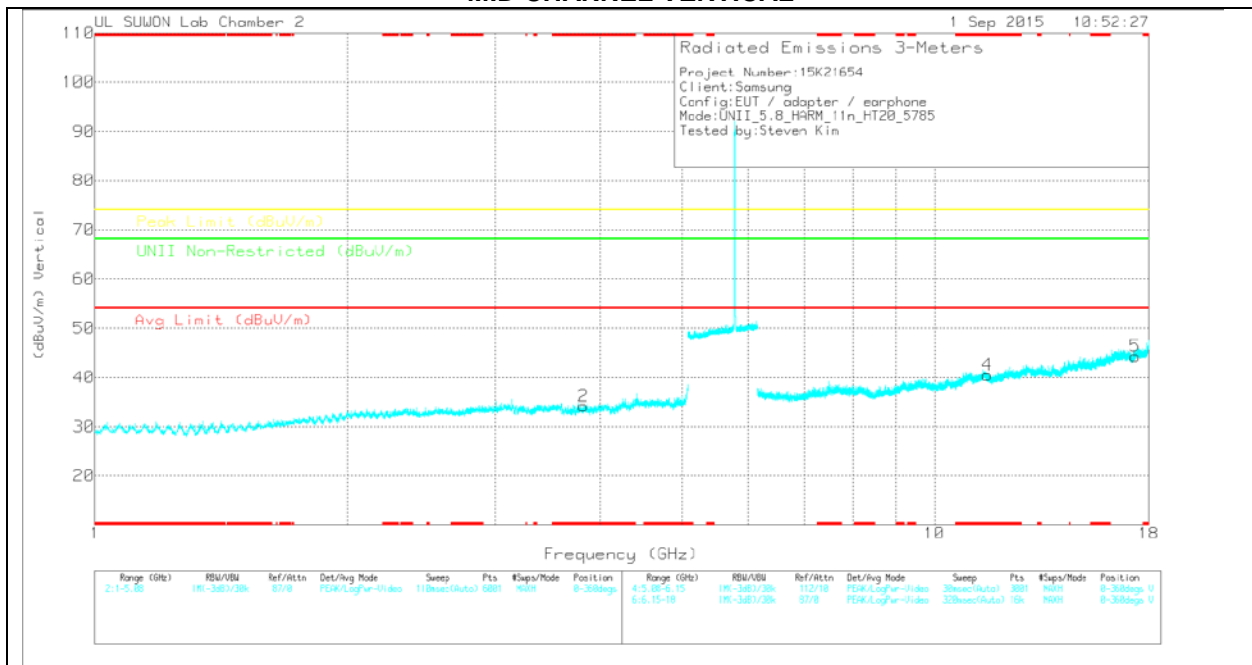

Note: Emission was scanned up to 40GHz; No emissions were detected above the noise floor which was at least 20dB below the specification limit.

MID CHANNEL DATA

TRACE MARKERS

Marker	Frequency (GHz)	Meter Reading (dBuV)	Det	3117/0016 8724_150 619	Path_4	DC Corr (dB)	Corrected Reading (dBuV/m)	Avg Limit (dBuV/m)	Margin (dB)	Peak Limit (dBuV/m)	Margin (dB)	UNII Non-Restricted (dBuV/m)	Margin (dB)	Azimuth (Degs)	Height (cm)	Polarity
1	* 3.845	25.94	PK	33.1	-25.5	0	33.54	-	-	74	-40.46	-	-	0-360	200	H
2	* 3.819	26.86	PK	33.1	-25.8	0	34.16	-	-	74	-39.84	-	-	0-360	100	V
3	* 11.569	19.49	PK	38.4	-17.5	0	40.39	-	-	74	-33.61	-	-	0-360	100	H
6	17.361	18.26	PK	41.2	-15	0	44.46	-	-	-	-	68.2	-23.74	0-360	100	H
4	* 11.575	19.6	PK	38.4	-17.5	0	40.5	-	-	74	-33.5	-	-	0-360	200	V
5	17.357	18.22	PK	41.2	-15.1	0	44.32	-	-	-	-	68.2	-23.88	0-360	100	V

* - indicates frequency in CFR15.205/IC7.2.2 Restricted Band

PK – Peak Detector

Note: Only peak measurement was performed. Because peak measurement result of unwanted emission is less than average limit (54dBuV/m).

HIGH CHANNEL HORIZONTAL

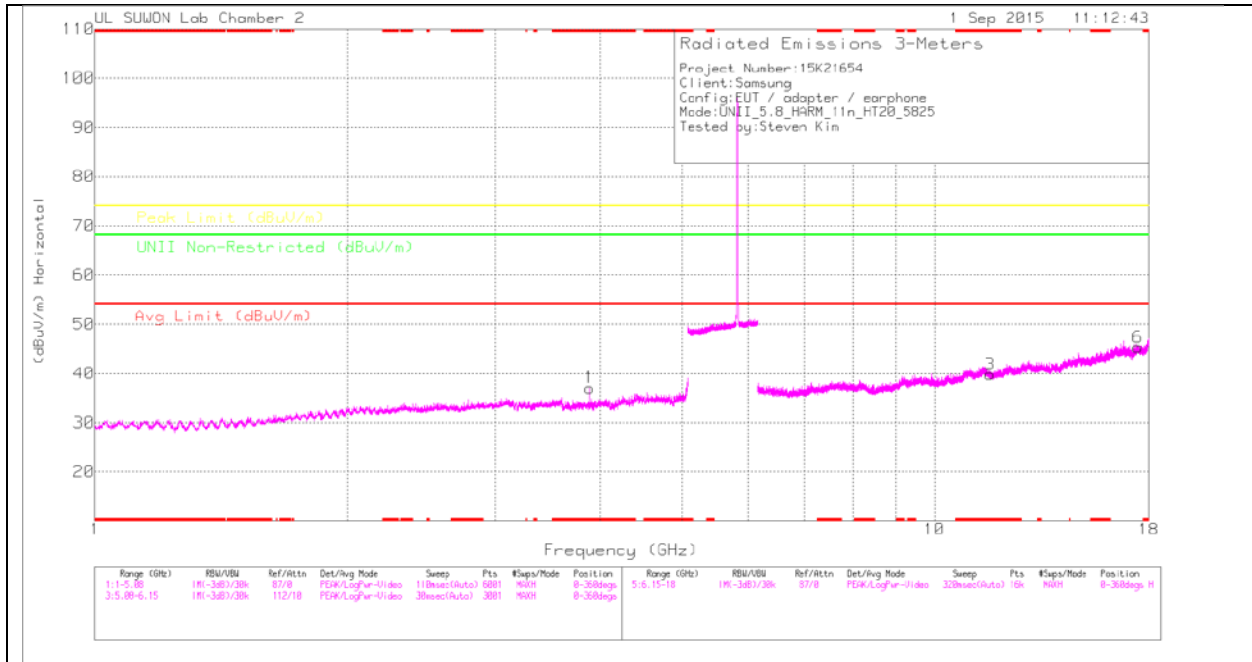

HIGH CHANNEL VERTICAL

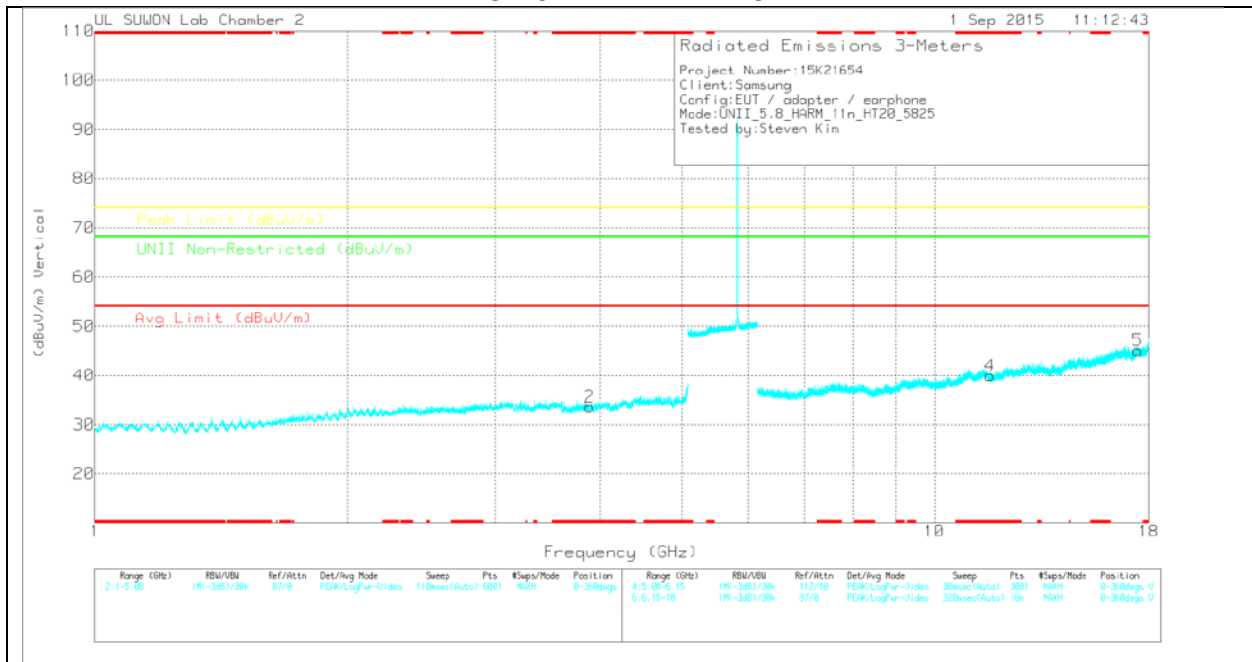

Note: Emission was scanned up to 40GHz; No emissions were detected above the noise floor which was at least 20dB below the specification limit.

HIGH CHANNEL DATA

TRACE MARKERS

Marker	Frequency (GHz)	Meter Reading (dBuV)	Det	3117(00168724)_150619	Path_4	DC Corr (dB)	Corrected Reading (dBuV/m)	Avg Limit (dBuV/m)	Margin (dB)	Peak Limit (dBuV/m)	Margin (dB)	UNII Non-Restricted (dBuV/m)	Margin (dB)	Azimuth (Degs)	Height (cm)	Polarity
1	* 3.883	29.46	PK	33.1	-25.5	0	37.06	-	-	74	-36.94	-	-	0-360	200	H
2	* 3.883	25.99	PK	33.1	-25.5	0	33.59	-	-	74	-40.41	-	-	0-360	100	V
3	* 11.652	18.77	PK	38.4	-17.4	0	39.77	-	-	74	-34.23	-	-	0-360	100	H
6	17.479	18.39	PK	41.3	-14.4	0	45.29	-	-	-	-	68.2	-22.91	0-360	200	H
4	* 11.647	18.93	PK	38.4	-17.4	0	39.93	-	-	74	-34.07	-	-	0-360	200	V
5	17.476	18.19	PK	41.3	-14.4	0	45.09	-	-	-	-	68.2	-23.11	0-360	200	V

* - indicates frequency in CFR15.205/IC7.2.2 Restricted Band

PK – Peak detector

Radiated Emissions

Frequency (GHz)	Meter Reading (dBuV)	Det	3117(00168724)_150619	Path_4	DC Corr (dB)	Corrected Reading (dBuV/m)	Avg Limit (dBuV/m)	Margin (dB)	Peak Limit (dBuV/m)	Margin (dB)	UNII Non-Restricted (dBuV/m)	Margin (dB)	Azimuth (Degs)	Height (cm)	Polarity
* 3.883	37.19	PK-U	33.1	-25.5	0	44.79	-	-	74	-29.21	-	-	247	345	H
* 3.883	27.93	ADR	33.1	-25.5	0	35.53	54	-18.47	-	-	-	-	247	345	H

* - indicates frequency in CFR15.205/IC7.2.2 Restricted Band

PK-U - U-NII: Maximum Peak

ADR - U-NII AD primary method, RMS average

11.4.3. TX ABOVE 1 GHz 802.11n HT40 MODE IN THE 5.8 GHz BAND HARMONICS AND SPURIOUS EMISSIONS HORIZONTAL PEAK PLOT

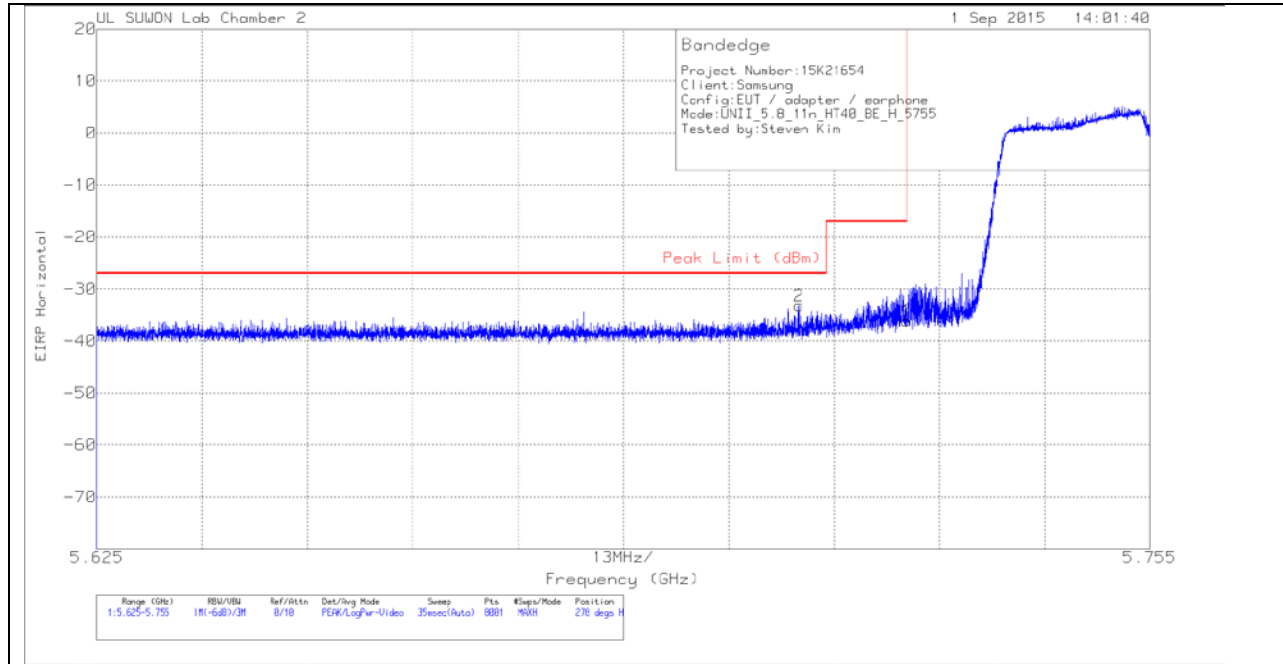

HORIZONTAL DATA

TRACE MARKERS

Marker	Frequency (GHz)	Meter Reading (dBm)	Det	3117(0016 8724)_150 619	Path_2_10 dB	Conversion Factor (dB)	DC Corr (dB)	Corrected Reading EIRP	Peak Limit (dBm)	PK Margin (dB)	Azimuth (Degs)	Height (cm)	Polarity
1	5.725	-67.07	Pk	34.7	-15.6	11.8	0	-36.17	-17	-19.17	278	327	H
2	5.712	-64.14	Pk	34.7	-15.6	11.8	0	-33.24	-27	-6.24	278	327	H

Pk - Peak detector

VERTICAL PEAK PLOT

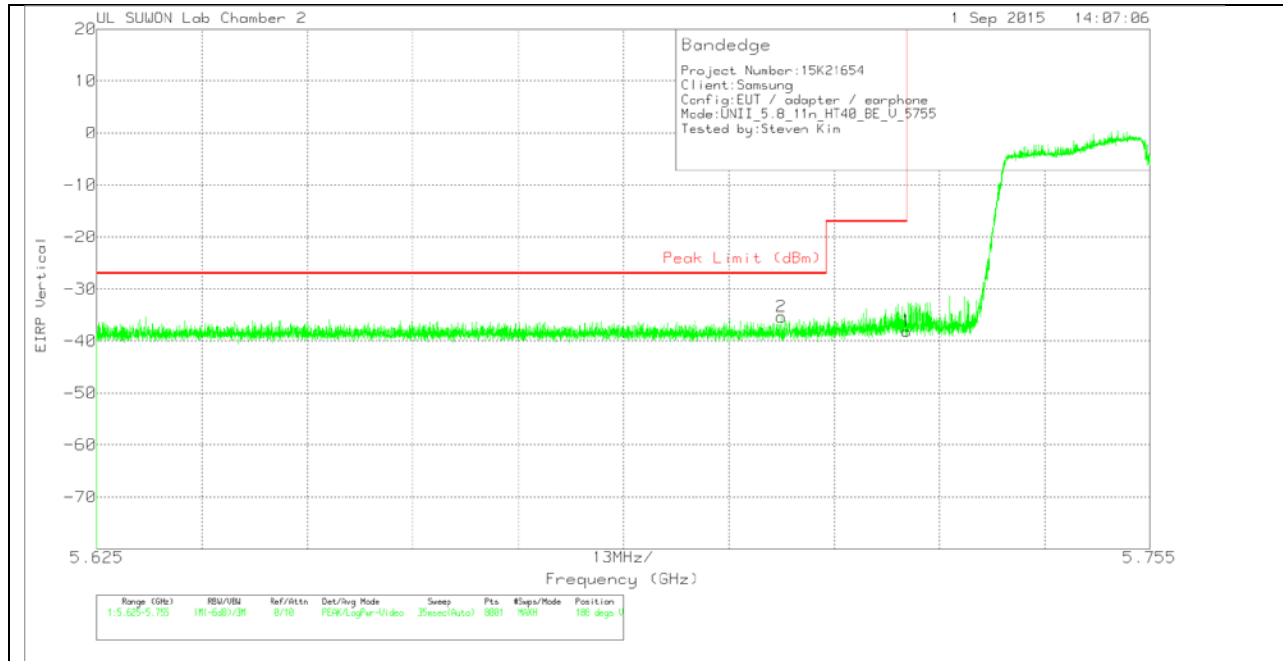

VERTICAL DATA

TRACE MARKERS

Marker	Frequency (GHz)	Meter Reading (dBm)	Det	3117(0016 8724)_150 619	Path_2_10 dB	Conversion Factor (dB)	DC Corr (dB)	Corrected Reading EIRP	Peak Limit (dBm)	PK Margin (dB)	Azimuth (Degs)	Height (cm)	Polarity
1	5.725	-69.03	Pk	34.7	-15.6	11.8	0	-38.13	-17	-21.13	188	118	V
2	5.71	-66.24	Pk	34.7	-15.6	11.8	0	-35.34	-27	-8.34	188	118	V

Pk - Peak detector

AUTHORIZED BANDEDGE (HIGH CHANNEL)

HORIZONTAL PEAK PLOT

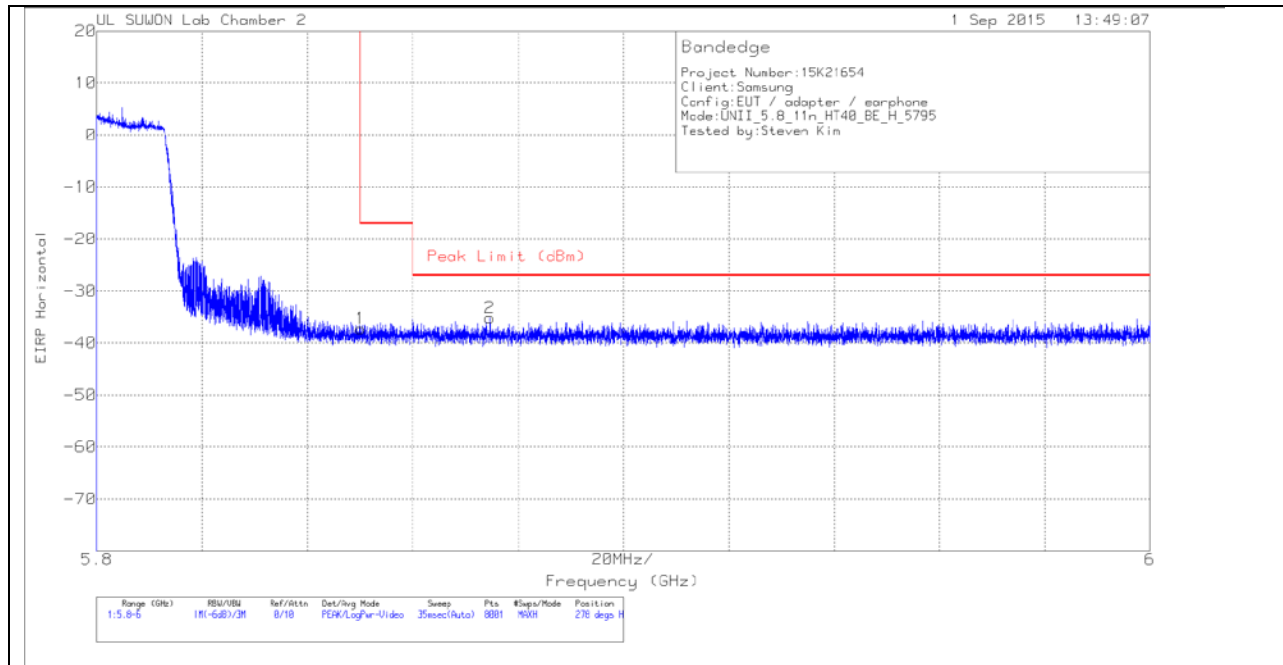

HORIZONTAL DATA

TRACE MARKERS

Marker	Frequency (GHz)	Meter Reading (dBm)	Det	3117(0016 8724)_150 619	Path_2_10 dB	Conversion Factor (dB)	DC Corr (dB)	Corrected Reading EIRP	Peak Limit (dBm)	PK Margin (dB)	Azimuth (Degs)	Height (cm)	Polarity
1	5.85	-68.22	Pk	34.7	-15.5	11.8	0	-37.22	-17	-20.22	278	321	H
2	5.875	-66.17	Pk	34.7	-15.5	11.8	0	-35.17	-27	-8.17	278	321	H

Pk - Peak detector

VERTICAL PEAK PLOT

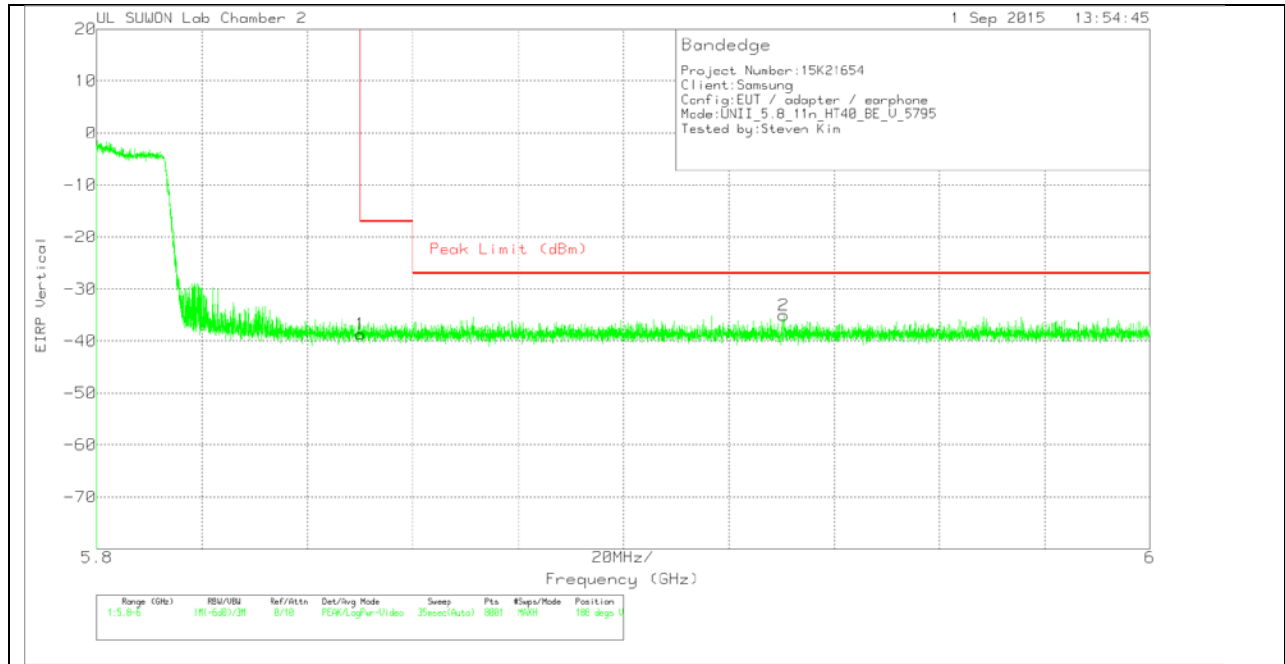

VERTICAL DATA

TRACE MARKERS

Marker	Frequency (GHz)	Meter Reading (dBm)	Det	3117(0016 8724)_150 619	Path_2_10 dB	Conversion Factor (dB)	DC Corr (dB)	Corrected Reading EIRP	Peak Limit (dBm)	PK Margin (dB)	Azimuth (Degs)	Height (cm)	Polarity
1	5.85	-69.67	Pk	34.7	-15.5	11.8	0	-38.67	-17	-21.67	188	373	V
2	5.93	-66.16	Pk	34.8	-15.5	11.8	0	-35.06	-27	-8.06	188	373	V

Pk - Peak detector

LOW CHANNEL HORIZONTAL

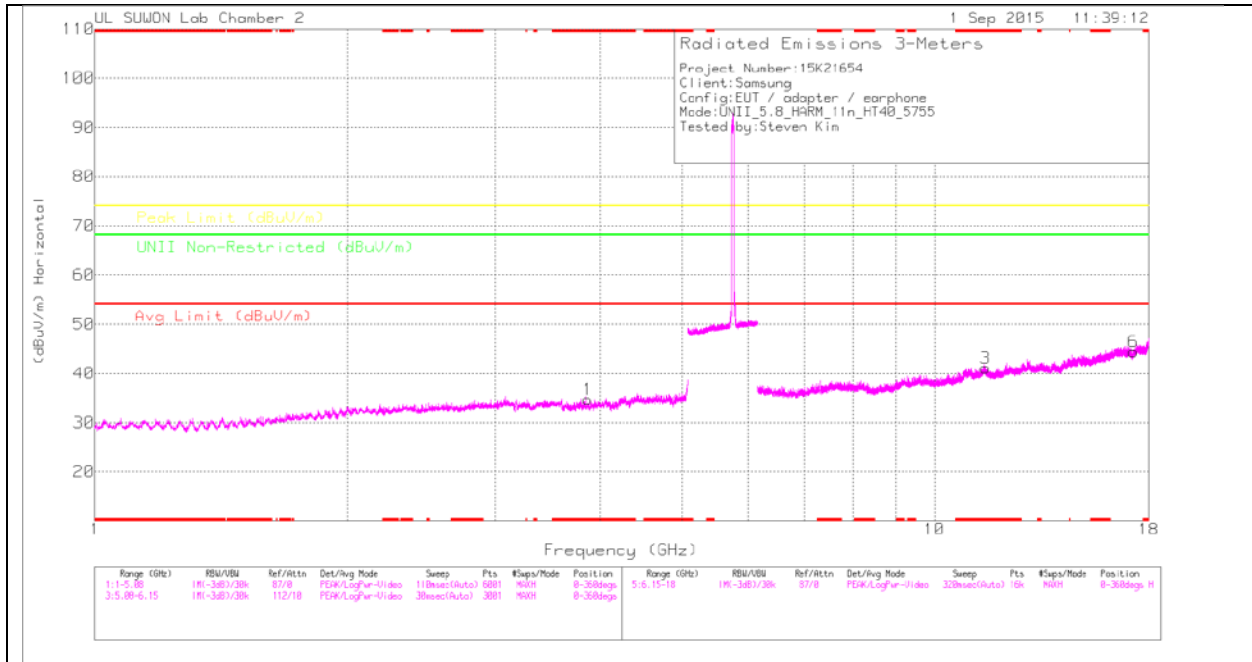

LOW CHANNEL VERTICAL

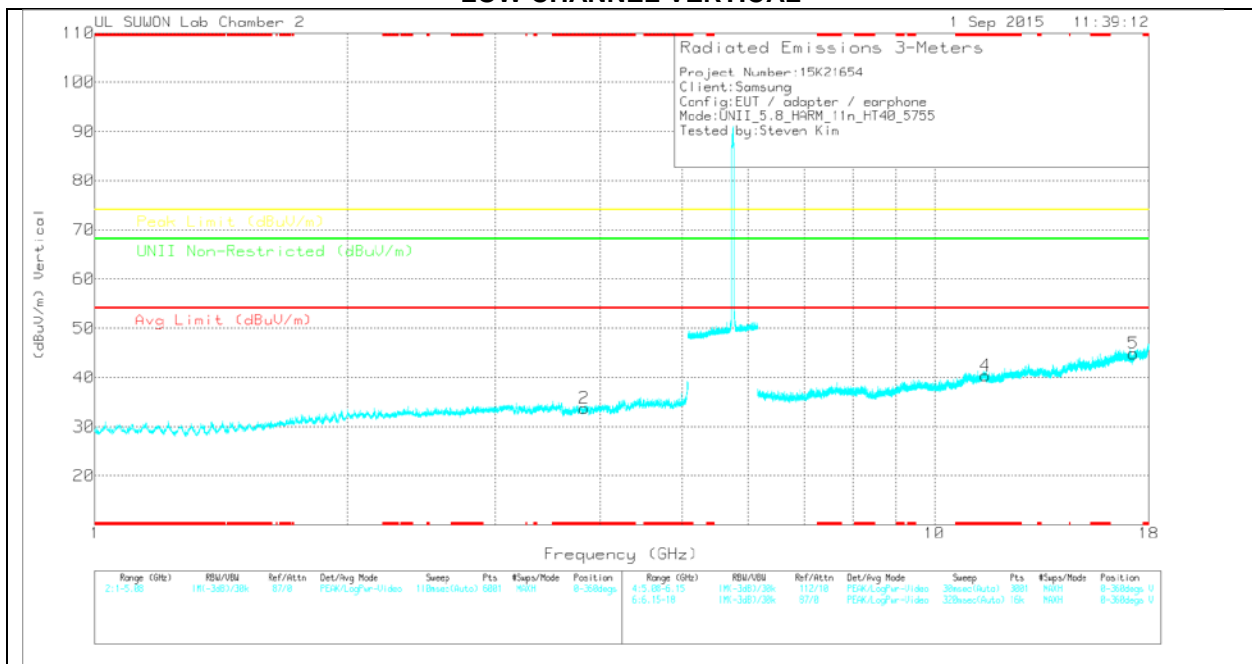

Note: Emission was scanned up to 40GHz; No emissions were detected above the noise floor which was at least 20dB below the specification limit.

LOW CHANNEL DATA

TRACE MARKERS

Marker	Frequency (GHz)	Meter Reading (dBuV)	Det	3117(0016 8724)_150 619	Path_4	DC Corr (dB)	Corrected Reading (dBuV/m)	Avg Limit (dBuV/m)	Margin (dB)	Peak Limit (dBuV/m)	Margin (dB)	UNII Non-Restricted (dBuV/m)	Margin (dB)	Azimuth (Degs)	Height (cm)	Polarity
1	* 3.861	27.09	PK	33.1	-25.5	0	34.69	-	-	74	-39.31	-	-	0-360	100	H
2	* 3.824	26.34	PK	33.1	-25.7	0	33.74	-	-	74	-40.26	-	-	0-360	200	V
3	* 11.513	20.29	PK	38.3	-17.5	0	41.09	-	-	74	-32.91	-	-	0-360	200	H
6	17.266	18.4	PK	41.2	-15.2	0	44.4	-	-	-	-	68.2	-23.8	0-360	200	H
4	* 11.508	19.56	PK	38.3	-17.5	0	40.36	-	-	74	-33.64	-	-	0-360	100	V
5	17.265	18.86	PK	41.2	-15.2	0	44.86	-	-	-	-	68.2	-23.34	0-360	200	V

* - indicates frequency in CFR15.205/IC7.2.2 Restricted Band

PK – Peak Detector

Note: Only peak measurement was performed. Because peak measurement result of unwanted emission is less than average limit (54dBuV/m).

HIGH CHANNEL HORIZONTAL

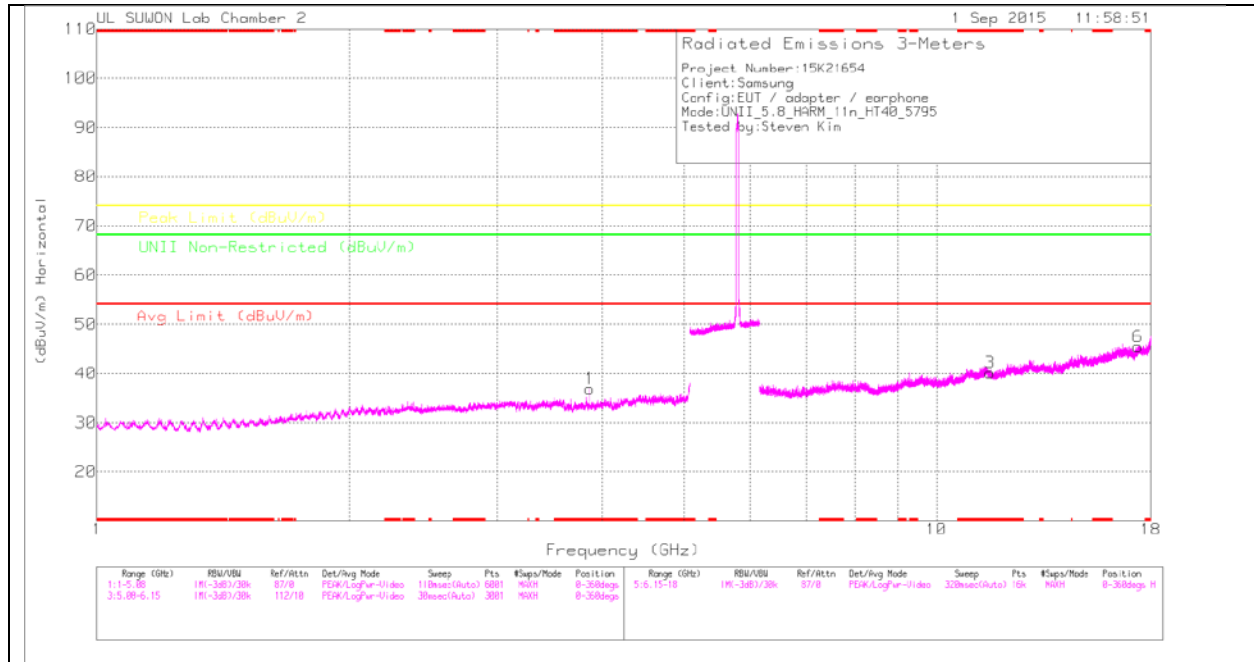

HIGH CHANNEL VERTICAL

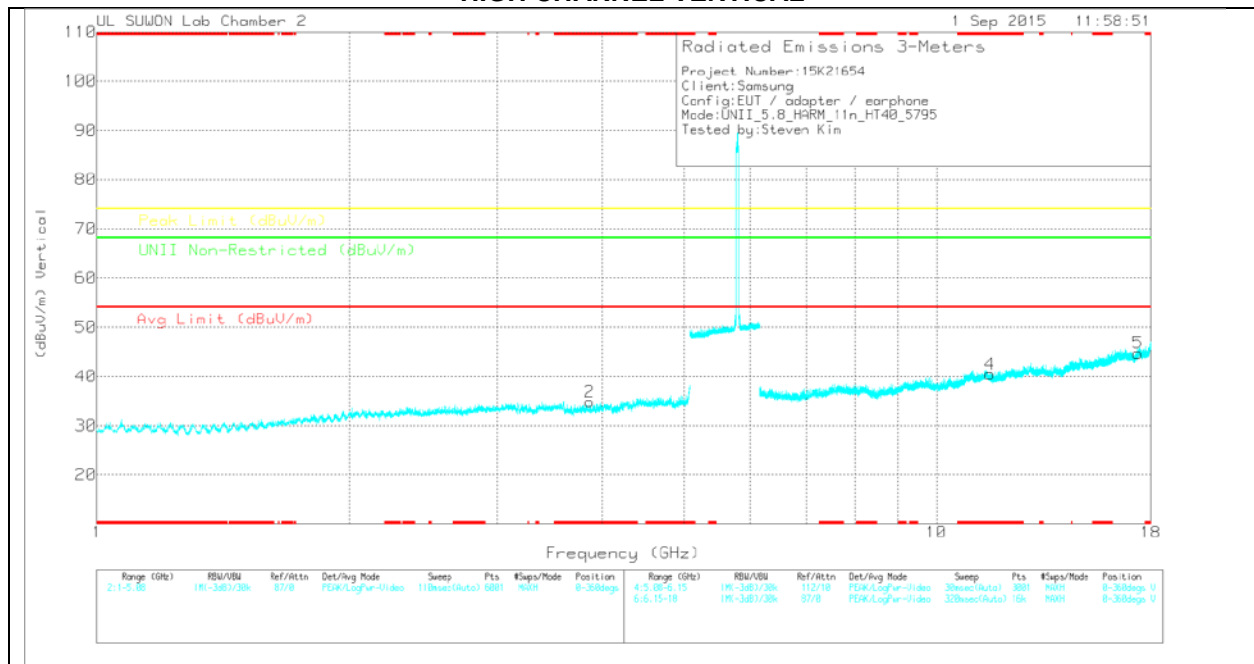

Note: Emission was scanned up to 40GHz; No emissions were detected above the noise floor which was at least 20dB below the specification limit.

HIGH CHANNEL DATA

TRACE MARKERS

Marker	Frequency (GHz)	Meter Reading (dBuV)	Det	3117/0016 8724_150 619	Path_4	DC Corr (dB)	Corrected Reading (dBuV/m)	Avg Limit (dBuV/m)	Margin (dB)	Peak Limit (dBuV/m)	Margin (dB)	UNII Non-Restricted (dBuV/m)	Margin (dB)	Azimuth (Degs)	Height (cm)	Polarity
1	* 3.863	29.27	PK	33.1	-25.5	0	36.87	-	-	74	-37.13	-	-	0-360	200	H
2	* 3.863	27.2	PK	33.1	-25.5	0	34.8	-	-	74	-39.2	-	-	0-360	200	V
3	* 11.59	19.13	PK	38.4	-17.4	0	40.13	-	-	74	-33.87	-	-	0-360	100	H
6	17.386	19.19	PK	41.2	-15	0	45.39	-	-	-	-	68.2	-22.81	0-360	200	H
4	* 11.587	19.42	PK	38.4	-17.4	0	40.42	-	-	74	-33.58	-	-	0-360	200	V
5	17.385	18.53	PK	41.2	-15	0	44.73	-	-	-	-	68.2	-23.47	0-360	200	V

* - indicates frequency in CFR15.205/IC7.2.2 Restricted Band

PK – Peak Detector

Note: Only peak measurement was performed. Because peak measurement result of unwanted emission is less than average limit (54dBuV/m).

11.4.4. TX ABOVE 1 GHz 802.11ac VHT80 MODE IN THE 5.8 GHz BAND HARMONICS AND SPURIOUS EMISSIONS HORIZONTAL PEAK PLOT

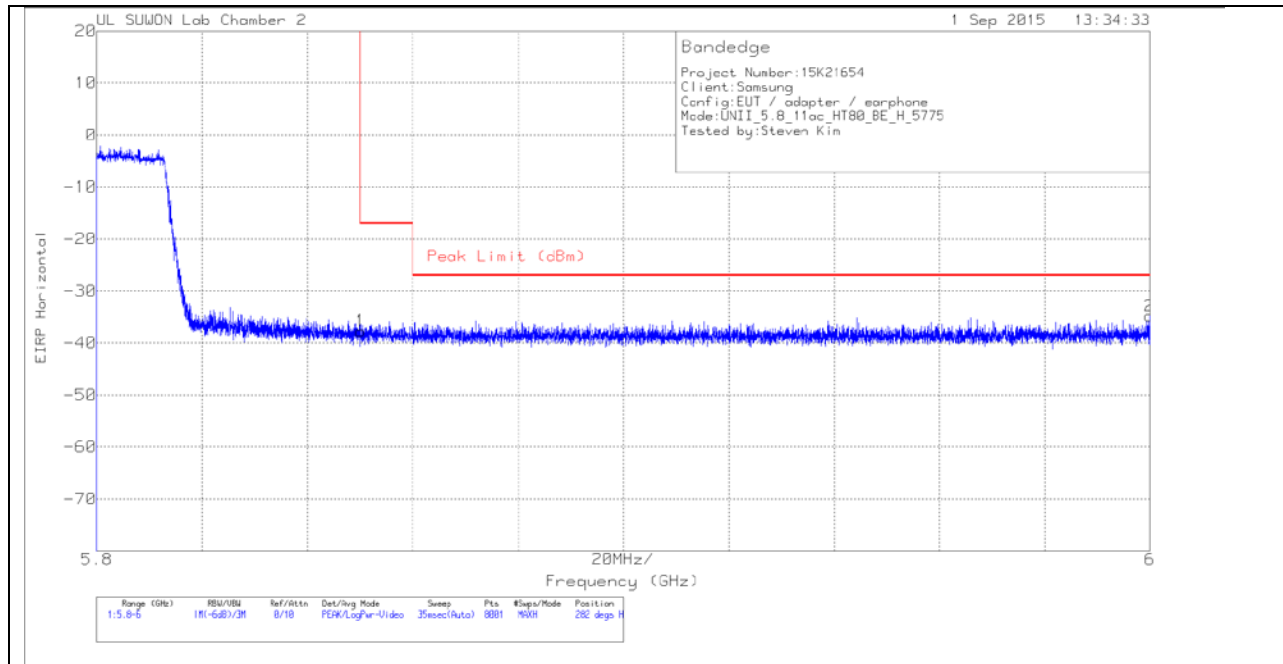

HORIZONTAL DATA

TRACE MARKERS

Marker	Frequency (GHz)	Meter Reading (dBm)	Det	3117(0016 8724)_150 619	Path_2_10 dB	Conversion Factor (dB)	DC Corr (dB)	Corrected Reading EIRP	Peak Limit (dBm)	PK Margin (dB)	Azimuth (Degs)	Height (cm)	Polarity
1	5.85	-68.68	Pk	34.7	-15.5	11.8	0	-37.68	-17	-20.68	282	322	H
2	6	-65.99	Pk	34.8	-15.4	11.8	0	-34.79	-27	-7.79	282	322	H

Pk - Peak detector

VERTICAL PEAK PLOT

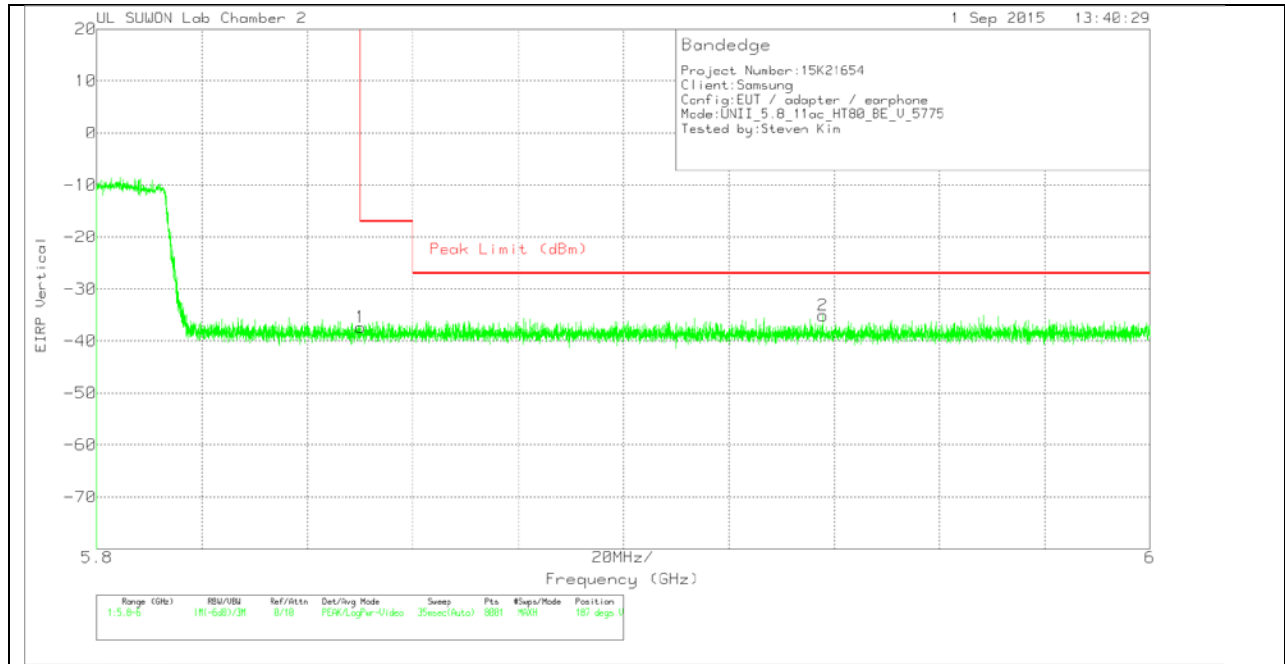

VERTICAL DATA

TRACE MARKERS

Marker	Frequency (GHz)	Meter Reading (dBm)	Det	3117(0016 8724)_150 619	Path_2_10 dB	Conversion Factor (dB)	DC Corr (dB)	Corrected Reading EIRP	Peak Limit (dBm)	PK Margin (dB)	Azimuth (Degs)	Height (cm)	Polarity
1	5.85	-68.37	Pk	34.7	-15.5	11.8	0	-37.37	-17	-20.37	187	100	V
2	5.938	-66.19	Pk	34.8	-15.5	11.8	0	-35.09	-27	-8.09	187	100	V

Pk - Peak detector

LOW CHANNEL HORIZONTAL

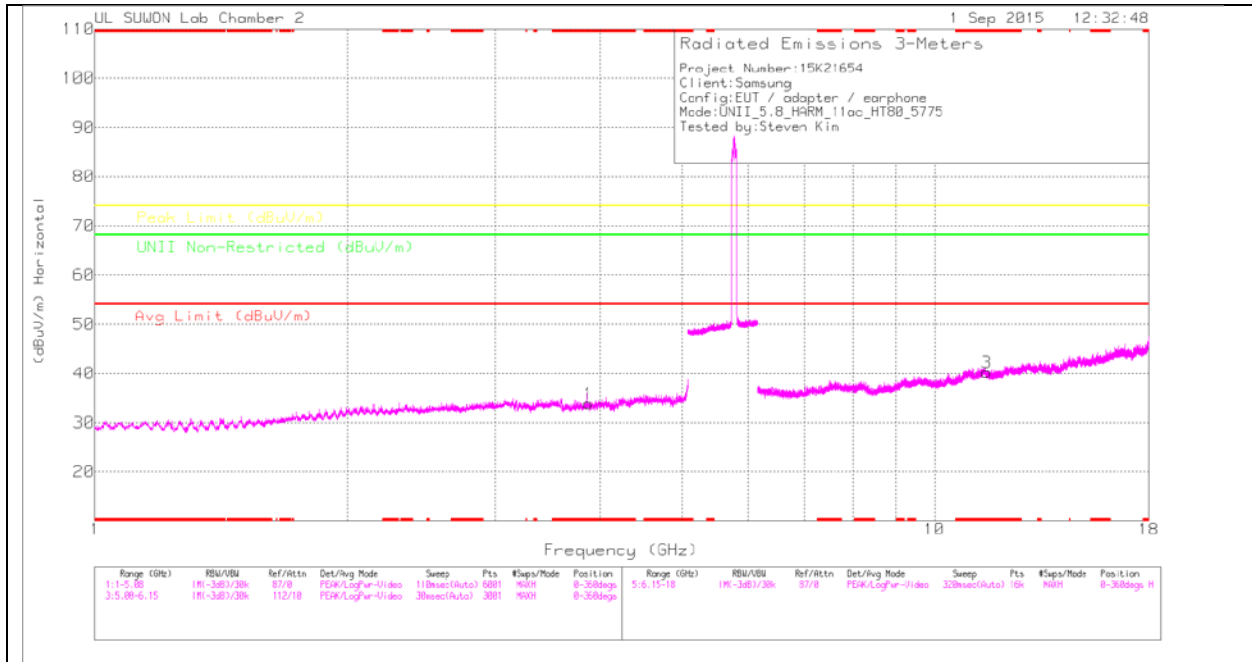

LOW CHANNEL VERTICAL

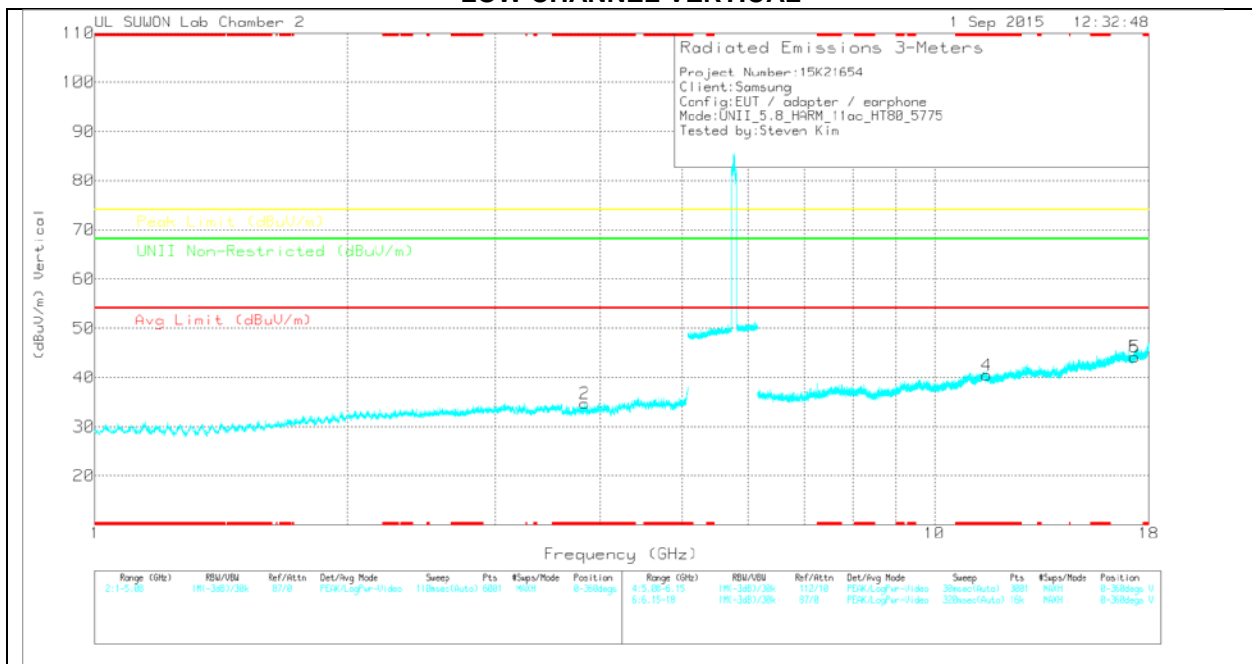

Note: Emission was scanned up to 40GHz; No emissions were detected above the noise floor which was at least 20dB below the specification limit.

LOW CHANNEL DATA

TRACE MARKERS

Marker	Frequency (GHz)	Meter Reading (dBuV)	Det	3117(0016 8724)_150 619	Path_4	DC Corr (dB)	Corrected Reading (dBuV/m)	Avg Limit (dBuV/m)	Margin (dB)	Peak Limit (dBuV/m)	Margin (dB)	UNII Non-Restricted (dBuV/m)	Margin (dB)	Azimuth (Degs)	Height (cm)	Polarity
1	* 3.872	26.17	PK	33.1	-25.5	0	33.77	-	-	74	-40.23	-	-	0-360	200	H
2	* 3.827	27.27	PK	33.1	-25.7	0	34.67	-	-	74	-39.33	-	-	0-360	100	V
3	* 11.551	19.3	PK	38.4	-17.5	0	40.2	-	-	74	-33.8	-	-	0-360	200	H
4	* 11.55	19.55	PK	38.4	-17.5	0	40.45	-	-	74	-33.55	-	-	0-360	200	V
5	17.326	18.06	PK	41.2	-15.1	0	44.16	-	-	-	-	68.2	-24.04	0-360	200	V
6	17.326	18.06	PK	41.2	-15.1	0	44.16	-	-	-	-	68.2	-24.04	0-360	200	V

* - indicates frequency in CFR15.205/IC7.2.2 Restricted Band

PK – Peak Detector

Note: Only peak measurement was performed. Because peak measurement result of unwanted emission is less than average limit (54dBuV/m).

12. WORST-CASE BELOW 1 GHz (in the 5.3 GHz Band)

SPURIOUS EMISSIONS 30 TO 1000 MHz (WORST-CASE CONFIGURATION, HORIZONTAL)

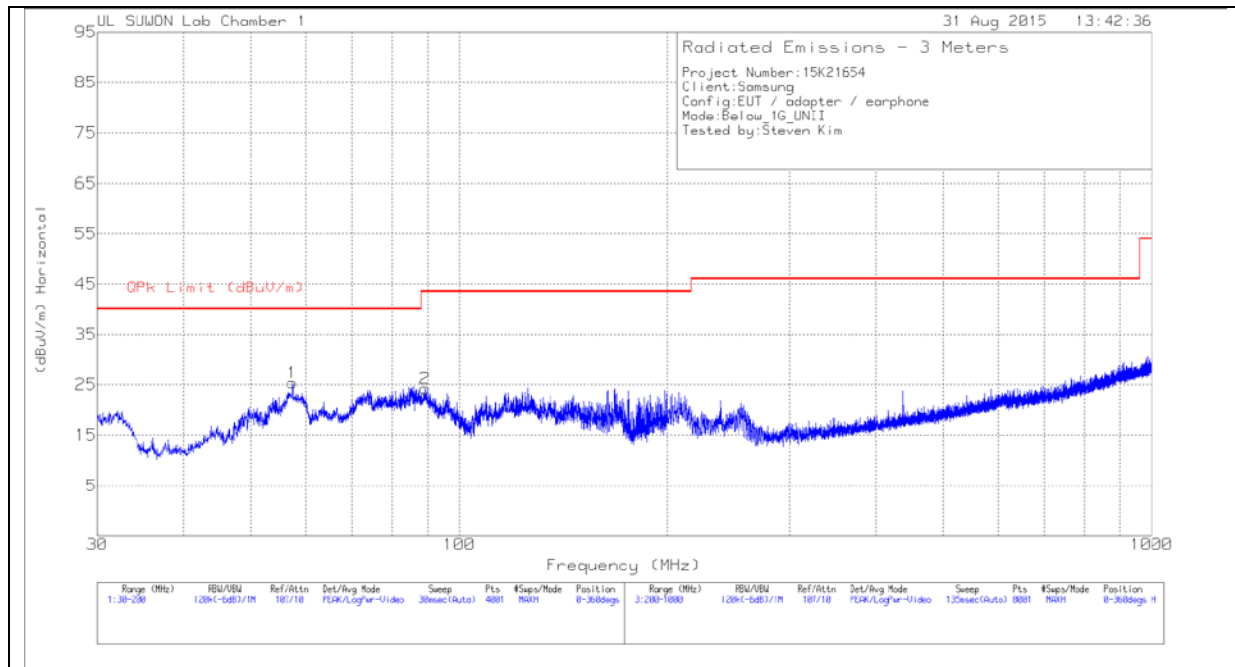

SPURIOUS EMISSIONS 30 TO 1000 MHz (WORST-CASE CONFIGURATION, VERTICAL)

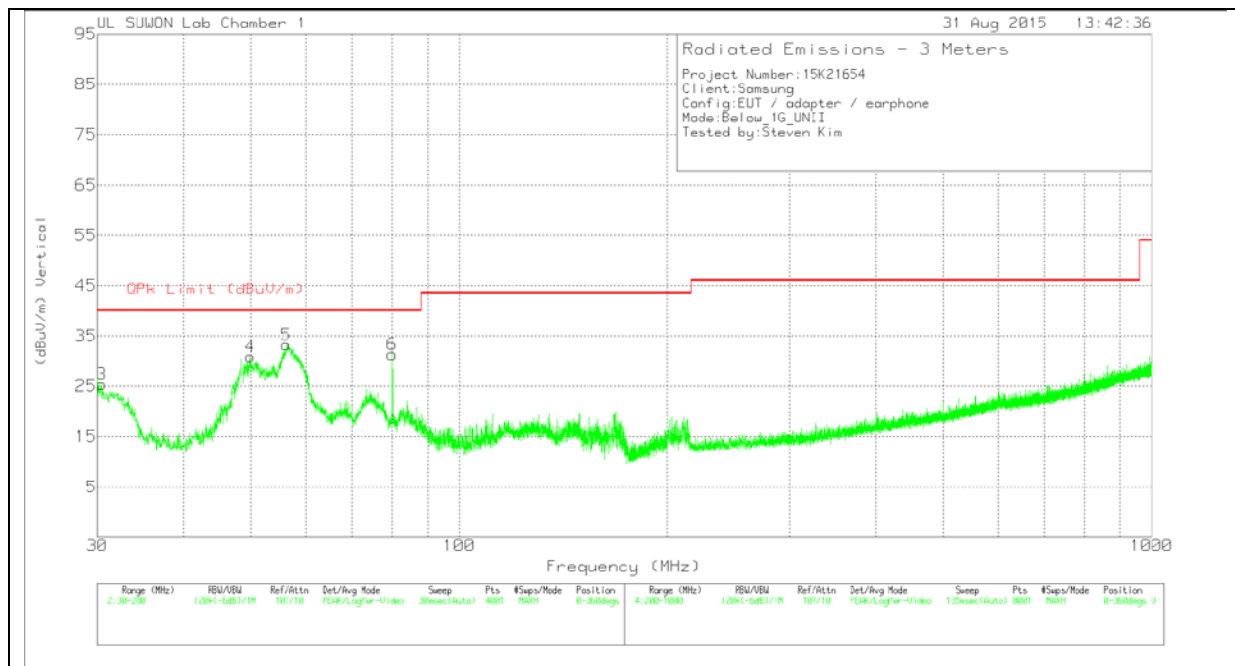

Below 1G Data

TRACE MARKERS

Marker	Frequency (MHz)	Meter Reading (dBuV)	Det	VULB9163-750	Bi-Log	Corrected Reading (dBuV/m)	QPk Limit (dBuV/m)	Margin (dB)	Azimuth (Degs)	Height (cm)	Polarity
1	57.4975	42.36	Pk	13	-30	25.36	40	-14.64	0-360	400	H
2	89.245	44.33	Pk	9.3	-29.4	24.23	43.52	-19.29	0-360	200	H
3	30.4675	45.6	Pk	10.3	-30.5	25.4	40	-14.6	0-360	100	V
4	49.9325	47.16	Pk	13.9	-30.2	30.86	40	-9.14	0-360	100	V
5	56.3075	50.11	Pk	13.1	-30	33.21	40	-6.79	0-360	100	V
6	79.98	54.02	Pk	6.9	-29.6	31.32	40	-8.68	0-360	100	V

* - indicates frequency in CFR15.205/IC7.2.2 Restricted Band

Pk - Peak detector

13. AC POWER LINE CONDUCTED EMISSIONS

LIMITS

FCC §15.207 (a)
IC RSS-GEN Clause 8.8

Frequency of Emission (MHz)	Conducted Limit (dBuV)	
	Quasi-peak	Average
0.15-0.5	66 to 56	56 to 46
0.5-5	56	46
5-30	60	50

* Decreases with the logarithm of the frequency.

TEST PROCEDURE

The EUT is placed on a non-conducting table 40 cm from the vertical ground plane and 80 cm above the horizontal ground plane. The EUT is configured in accordance with ANSI C63.10.

The receiver is set to a resolution bandwidth of 9 kHz. Peak detection is used unless otherwise noted as quasi-peak or average.

Line conducted data is recorded for both NEUTRAL and HOT lines.

RESULTS

6 WORST EMISSIONS

LINE 1 PLOT

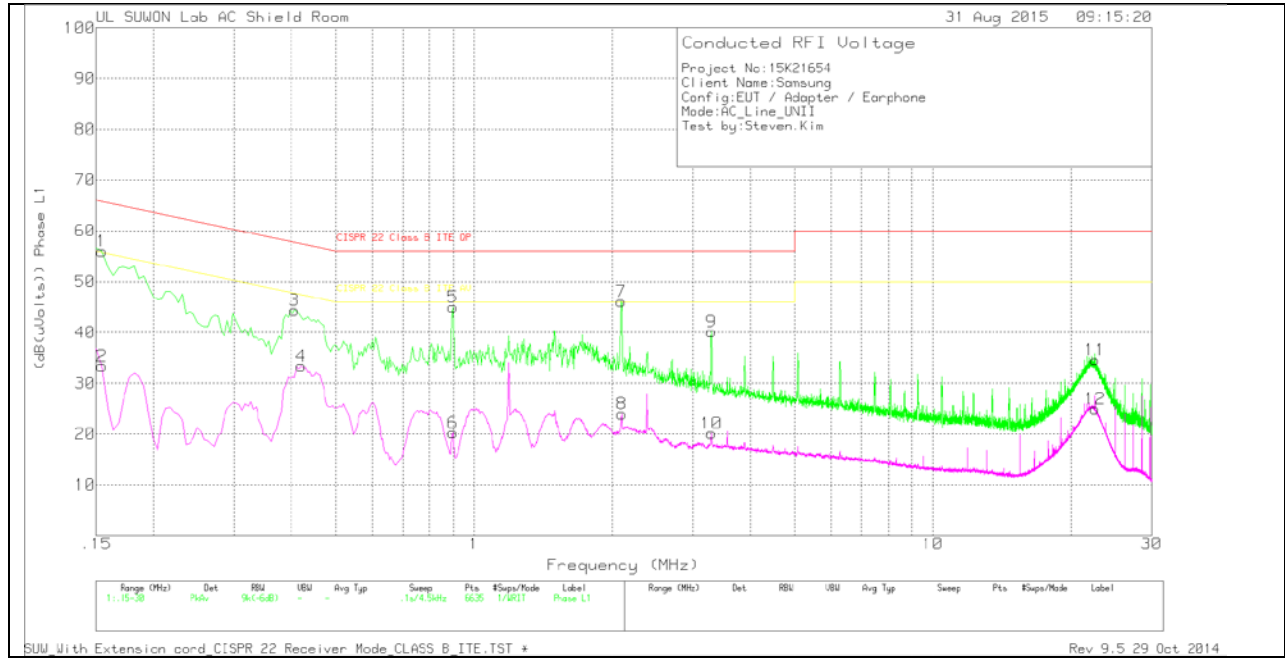

LINE 1 RESULTS

TRACE MARKERS

Phase L1 .15 - 30MHz

Marker	Frequency (MHz)	Meter Reading (dBuV)	Det	101837_w ith ex- cord_L1	CE Shield Room	Corrected Reading (dBuV)	CISPR 22 Class B ITE QP	Margin (dB)	CISPR 22 Class B ITE AV	Margin (dB)
1	.1545	46.06	Pk	9.9	0	55.96	65.75	-9.79	-	-
2	.1545	23.5	Av	9.9	0	33.4	-	-	55.75	-22.35
3	.4065	34.27	Pk	10.1	0	44.37	57.72	-13.35	-	-
4	.42	23.29	Av	10.1	0	33.39	-	-	47.45	-14.06
5	.897	35.05	Pk	9.9	0	44.95	56	-11.05	-	-
6	.897	10.32	Av	9.9	0	20.22	-	-	46	-25.78
7	2.0895	36.25	Pk	9.8	.1	46.15	56	-9.85	-	-
8	2.094	14.01	Av	9.8	.1	23.91	-	-	46	-22.09
9	3.291	30.24	Pk	9.8	.1	40.14	56	-15.86	-	-
10	3.291	10.19	Av	9.8	.1	20.09	-	-	46	-25.91
11	22.5825	23.91	Pk	10.5	.2	34.61	60	-25.39	-	-
12	22.578	14.29	Av	10.5	.2	24.99	-	-	50	-25.01

Pk - Peak detector

Av - Average detection

Quasi-Peak Emissions

Phase L1 .15 - 30MHz

Frequency (MHz)	Meter Reading (dBuV)	Det	101837_wit h ex-cord_L1	CE Shield Room	Corrected Reading (dBuV)	CISPR 22 Class B ITE QP	Margin (dB)	CISPR 22 Class B ITE AV	Margin (dB)
.15	43.92	Qp	9.8	0	53.72	66	-12.28	-	-
2.0931	31.93	Qp	9.8	.1	41.83	56	-14.17	-	-

Qp - Quasi-Peak detector

LINE 2 PLOT

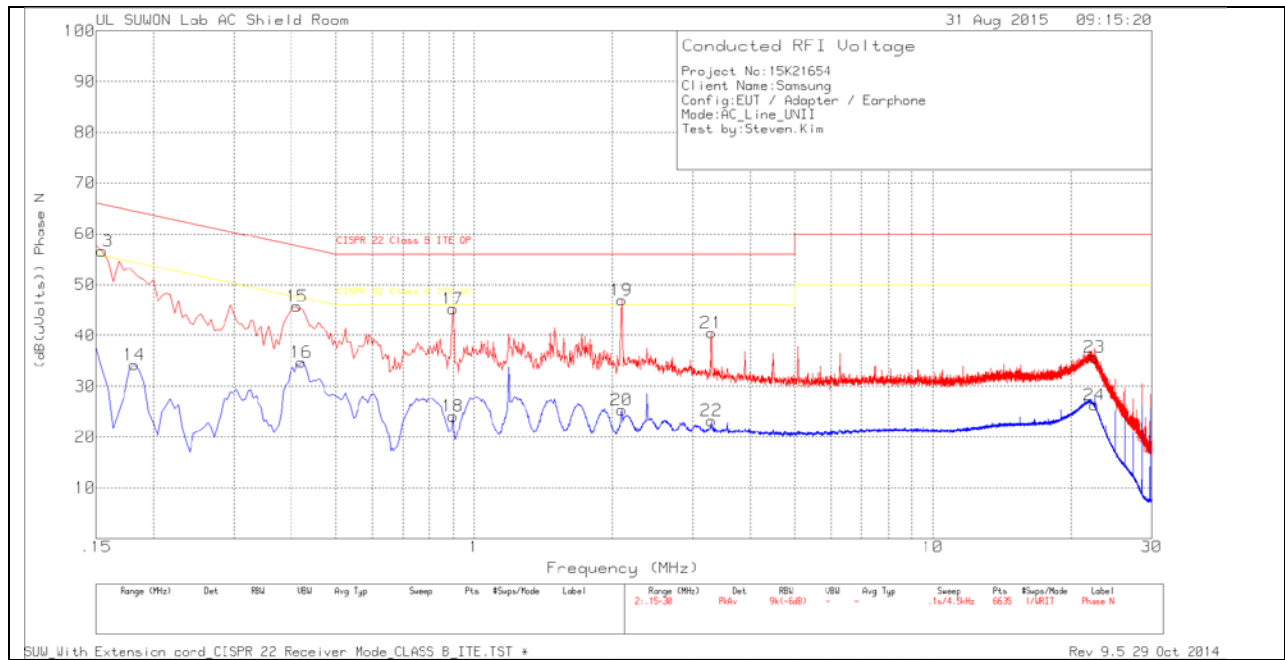

LINE 2 RESULTS

TRACE MARKERS

Phase N .15 - 30MHz

Marker	Frequency (MHz)	Meter Reading (dBuV)	Det	101837_w ith ex-cord_N	CE Shield Room	Corrected Reading (dBuV)	CISPR 22 Class B ITE QP	Margin (dB)	CISPR 22 Class B ITE AV	Margin (dB)
13	.1545	46.73	Pk	9.9	0	56.63	65.75	-9.12	-	-
14	.1815	24.15	Av	10.1	0	34.25	-	-	54.42	-20.17
15	.411	35.64	Pk	10.1	0	45.74	57.63	-11.89	-	-
16	.42	24.6	Av	10.1	0	34.7	-	-	47.45	-12.75
17	.897	35.32	Pk	9.9	0	45.22	56	-10.78	-	-
18	.897	14.21	Av	9.9	0	24.11	-	-	46	-21.89
19	2.094	37.05	Pk	9.8	.1	46.95	56	-9.05	-	-
20	2.094	15.42	Av	9.8	.1	25.32	-	-	46	-20.68
21	3.2865	30.67	Pk	9.8	.1	40.57	56	-15.43	-	-
22	3.291	13.32	Av	9.8	.1	23.22	-	-	46	-22.78
23	22.48125	24.77	Pk	10.7	.2	35.67	60	-24.33	-	-
24	22.4835	15.41	Av	10.7	.2	26.31	-	-	50	-23.69

Pk - Peak detector

Av - Average detection

Quasi-Peak Emissions

Phase N .15 - 30MHz

Frequency (MHz)	Meter Reading (dBuV)	Det	101837_wit h ex-cord_N	CE Shield Room	Corrected Reading (dBuV)	CISPR 22 Class B ITE QP	Margin (dB)	CISPR 22 Class B ITE AV	Margin (dB)
.15	44.76	Qp	9.8	0	54.56	66	-11.44	-	-
2.094	31.89	Qp	9.8	.1	41.79	56	-14.21	-	-

Qp - Quasi-Peak detector

14. DYNAMIC FREQUENCY SELECTION

14.1. OVERVIEW

14.1.1. LIMITS

INDUSTRY CANADA

IC RSS-210 is closely harmonized with FCC Part 15 DFS rules. The deviations are as follows:

RSS-247 Issue §6.3

Note: For the band 5600–5650 MHz, no operation is permitted.

Until further notice, devices subject to this annex shall not be capable of transmitting in the band 5600–5650 MHz. This restriction is for the protection of Environment Canada weather radars operating in this band.

FCC

§15.407 (h), FCC KDB 905462 D02 “COMPLIANCE MEASUREMENT PROCEDURES FOR UNLICENSED-NATIONAL INFORMATION INFRASTRUCTURE DEVICES OPERATING IN THE 5250-5350 MHz AND 5470-5725 MHz BANDS INCORPORATING DYNAMIC FREQUENCY SELECTION” and KDB 905462 D03 “U-NII CLIENT DEVICES WITHOUT RADAR DETECTION CAPABILITY”.

Table 1: Applicability of DFS requirements prior to use of a channel

Requirement	Operational Mode		
	Master	Client (without radar detection)	Client (with radar detection)
Non-Occupancy Period	Yes	Not required	Yes
DFS Detection Threshold	Yes	Not required	Yes
Channel Availability Check Time	Yes	Not required	Not required
U-NII Detection Bandwidth	Yes	Not required	Yes

Table 2: Applicability of DFS requirements during normal operation

Requirement	Operational Mode		
	Master	Client (without DFS)	Client (with DFS)
DFS Detection Threshold	Yes	Not required	Yes
Channel Closing Transmission Time	Yes	Yes	Yes
Channel Move Time	Yes	Yes	Yes
U-NII Detection Bandwidth	Yes	Not required	Yes

Additional requirements for devices with multiple bandwidth modes	Master Device or Client with Radar DFS	Client (without DFS)
U-NII Detection Bandwidth and Statistical Performance Check	All BW modes must be tested	Not required
Channel Move Time and Channel Closing Transmission Time	Test using widest BW mode available	Test using the widest BW mode available for the link
All other tests	Any single BW mode	Not required
Note: Frequencies selected for statistical performance check (Section 7.8.4) should include several frequencies within the radar detection bandwidth and frequencies near the edge of the radar detection bandwidth. For 802.11 devices it is suggested to select frequencies in all 20 MHz channel blocks and a null frequency between the bonded 20 MHz channel blocks.		

Table 3: Interference Threshold values, Master or Client incorporating In-Service Monitoring

Maximum Transmit Power	Value (see notes)
E.I.R.P. \geq 200 mill watt	-64 dBm
E.I.R.P. < 200 mill watt and power spectral density < 10 dBm/MHz	-62 dBm
E.I.R.P. < 200 mill watt that do not meet power spectral density requirement	-64 dBm
<p>Note 1: This is the level at the input of the receiver assuming a 0 dBi receive antenna</p> <p>Note 2: Throughout these test procedures an additional 1 dB has been added to the amplitude of the test transmission waveforms to account for variations in measurement equipment. This will ensure that the test signal is at or above the detection threshold level to trigger a DFS response.</p> <p>Note 3: E.I.R.P. is based on the highest antenna gain. For MIMO devices refer to KDB publication 662911 D01.</p>	

Table 4: DFS Response requirement values

Parameter	Value
<i>Non-occupancy period</i>	30 minutes
<i>Channel Availability Check Time</i>	60 seconds
<i>Channel Move Time</i>	10 seconds (See Note 1)
<i>Channel Closing Transmission Time</i>	200 milliseconds + approx. 60 milliseconds over remaining 10 second period. (See Notes 1 and 2)
<i>U-NII Detection Bandwidth</i>	Minimum 100% of the U-NII 99% transmission power bandwidth. (See Note 3)
<p>Note 1: <i>Channel Move Time</i> and the <i>Channel Closing Transmission Time</i> should be performed with Radar Type 0. The measurement timing begins at the end of the Radar Type 0 burst.</p> <p>Note 2: The <i>Channel Closing Transmission Time</i> is comprised of 200 milliseconds starting at the beginning of the <i>Channel Move Time</i> plus any additional intermittent control signals required to facilitate a <i>Channel</i> move (an aggregate of 60 milliseconds) during the remainder of the 10 second period. The aggregate duration of control signals will not count quiet periods in between transmissions.</p> <p>Note 3: During the <i>U-NII Detection Bandwidth</i> detection test, radar type 0 should be used. For each frequency step the minimum percentage of detection is 90 percent. Measurements are performed with no data traffic.</p>	

Table 5 – Short Pulse Radar Test Waveforms

Radar Type	Pulse Width (usec)	PRI (usec)	Pulses	Minimum Percentage of Successful Detection	Minimum Trials
0	1	1428	18	See Note 1	See Note 1
1	1	Test A: 15 unique PRI values randomly selected from the list of 23 PRI values in table 5a	Roundup: $\{(1/360) \times (19 \times 10^6 \text{ PRI}_{\text{usec}})\}$	60%	30
		Test B: 15 unique PRI values randomly selected within the range of 518-3066 usec. With a minimum increment of 1 usec, excluding PRI values selected in Test A			
2	1-5	150-230	23-29	60%	30
3	6-10	200-500	16-18	60%	30
4	11-20	200-500	12-16	60%	30
Aggregate (Radar Types 1-4)				80%	120
Note 1: Short Pulse Radar Type 0 should be used for the <i>Detection Bandwidth</i> test, <i>Channel Move Time</i> , and <i>Channel Closing Time</i> tests.					

Table 6 – Long Pulse Radar Test Signal

Radar Waveform Type	Pulse Width (µsec)	Chirp Width (MHz)	PRI (µsec)	Pulses per Burst	Number of Bursts	Minimum Percentage of Successful Detection	Minimum Trials
5	50-100	5-20	1000-2000	1-3	8-20	80%	30

Table 7 – Frequency Hopping Radar Test Signal

Radar Waveform Type	Pulse Width (µsec)	PRI (µsec)	Pulses per Hop	Hopping Rate (kHz)	Hopping Sequence Length (msec)	Minimum Percentage of Successful Detection	Minimum Trials
6	1	333	9	0.333	300	70%	30

14.1.1. TEST AND MEASUREMENT SYSTEM

CONDUCTED METHOD SYSTEM BLOCK DIAGRAM

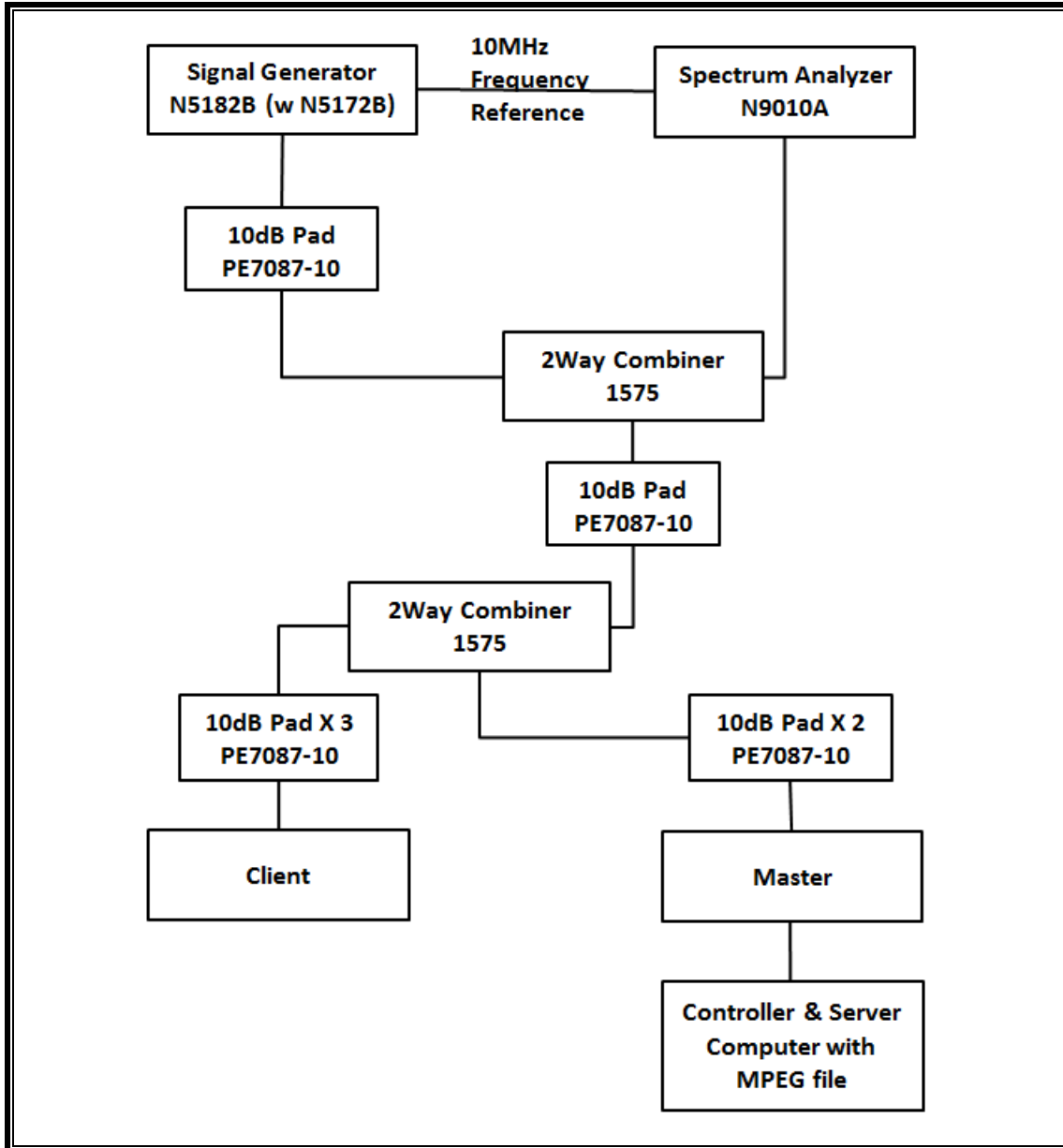

SYSTEM OVERVIEW

The short pulse and long pulse signal generating system utilizes the Keysite Signal Studio for Pulse Building as N5172B. The Vector Signal Generator has been validated by the NTIA. The hopping signal generating system utilizes the CCS simulated hopping method and system, which has been validated by the DoD, FCC and NTIA. The software selects waveform parameters from within the bounds of the signal type on a random basis using uniform distribution.

The short pulse types 1, 2, 3 and 4, and the long pulse type 5 parameters are randomized at run-time.

The hopping type 6 pulse parameters are fixed while the hopping sequence is based on the August 2005 NTIA Hopping Frequency List. The initial starting point randomized at run-time and each subsequent starting point is incremented by 475. Each frequency in the 100-length segment is compared to the boundaries of the EUT Detection Bandwidth and the software creates a hopping burst pattern in accordance with Section 7.4.1.3 Method #2 Simulated Frequency Hopping Radar Waveform Generating Subsystem of KDB 905462 D02. The frequency of the signal generator is incremented in 1 MHz steps from F_L to F_H for each successive trial. This incremental sequence is repeated as required to generate a minimum of 30 total trials and to maintain a uniform frequency distribution over the entire Detection Bandwidth.

The signal monitoring equipment consists of a spectrum analyzer. The aggregate ON time is calculated by multiplying the number of bins above a threshold during a particular observation period by the dwell time per bin, with the analyzer set to peak detection and max hold.

SYSTEM CALIBRATION

A 50-ohm load is connected in place of the spectrum analyzer, and the spectrum analyzer is connected to a horn antenna via a coaxial cable, with the reference level offset set to (horn antenna gain – coaxial cable loss). The signal generator is set to CW mode. The amplitude of the signal generator is adjusted to yield a level of –64 dBm as measured on the spectrum analyzer.

Without changing any of the instrument settings, the spectrum analyzer is reconnected to the Common port of the Spectrum Analyzer Combiner/Divider. The Reference Level Offset of the spectrum analyzer is adjusted so that the displayed amplitude of the signal is –64 dBm.

The spectrum analyzer displays the level of the signal generator as received at the antenna ports of the Master Device. The interference detection threshold may be varied from the calibrated value of –64 dBm and the spectrum analyzer will still indicate the level as received by the Master Device.

ADJUSTMENT OF DISPLAYED TRAFFIC LEVEL

A link is established between the Master and Slave and the distance between the units is adjusted as needed to provide a suitable received level at the Master and Slave devices. The video test file is streamed to generate WLAN traffic. The monitoring antenna is adjusted so that the WLAN traffic level, as displayed on the spectrum analyzer, is at lower amplitude than the radar detection threshold.

TEST AND MEASUREMENT EQUIPMENT

The following test and measurement equipment was utilized for the DFS tests documented in this report:

TEST EQUIPMENT LIST				
Description	Manufacturer	Model	S/N	Cal Due
Spectrum Analyzer, 7 GHz	Agilent / HP	N9010A	MY54200580	08-19-16
Vector Signal Generator, 6GHz	Agilent / HP	N5182B	MY53051241	08-19-16

14.1.2. SETUP OF EUT

CONDUCTED METHOD EUT TEST SETUP

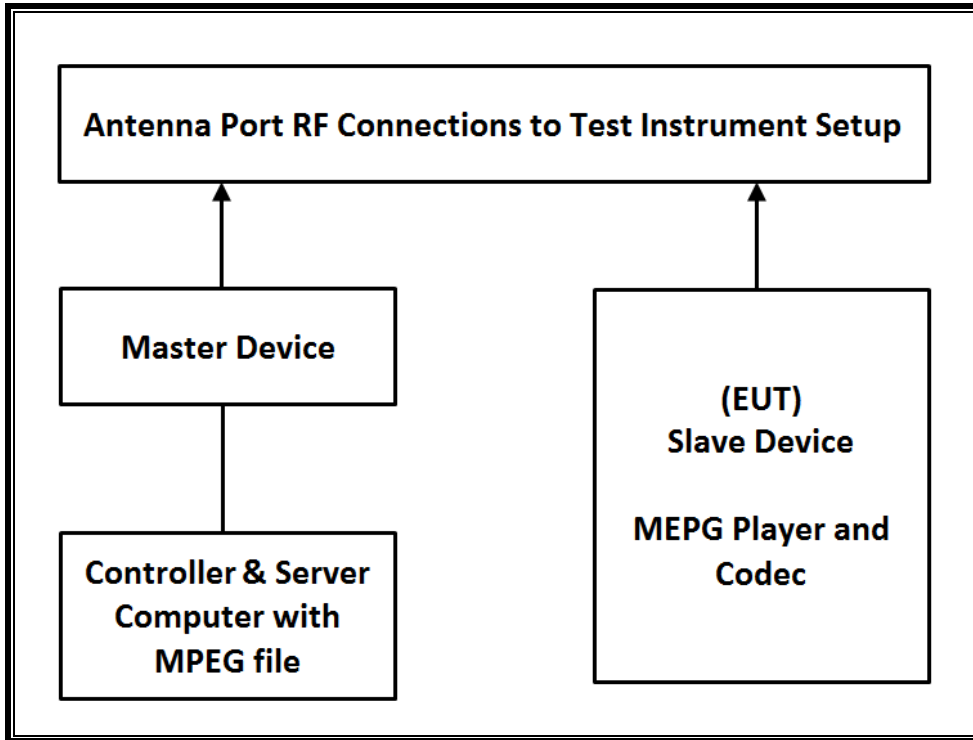

SUPPORT EQUIPMENT

The following support equipment was utilized for the DFS tests documented in this report:

PERIPHERAL SUPPORT EQUIPMENT LIST				
Description	Manufacturer	Model	Serial Number	FCC ID
Wireless Access Point	Cisco	AIR-CAP3702E-A-K9	FTX182276QX	LDK102087
Notebook PC (Controller/Server)	HP	HP EliteDesk 800 G1 TWR	CZC4125J25	DoC

14.1.3. DESCRIPTION OF EUT

The EUT operates over the 5250-5350 MHz and 5470-5725 MHz ranges.

The EUT is a Slave Device without Radar Detection.

The highest power level within these bands is 11.163 dBm in the 5250-5350 MHz band and 11.253 dBm in the 5470-5725 MHz band.

The antenna assembly utilized antenna with the EUT is -0.08 dBi.

The rated output power of the Master unit is > 23dBm (EIRP). Therefore the required interference threshold level is -64 dBm. After correction for procedural adjustments, the required conducted threshold at the antenna port is $-64 + 1 = -63$ dBm.

The calibrated radiated DFS Detection Threshold level is set to -64 dBm. The tested level is lower than the required level hence it provides a margin to the limit.

The EUT uses one transmitter/receiver chain connected to an antenna to perform radiated tests.

WLAN traffic that meets or exceeds the minimum required loading was generated by transferring a data stream from the controller/server PC to the EUT using iPerf version 2.0.5 software package.

TPC is not required since the maximum EIRP is less than 500 mW (27 dBm).

The EUT utilizes the 802.11ac architecture. Three nominal channel bandwidths are implemented: 20 MHz, 40 MHz and 80 MHz.

The software installed in the access point is 12.4(25d)JA1.

UNIFORM CHANNEL SPREADING

This requirement is not applicable to Slave radio devices.

OVERVIEW OF MASTER DEVICE WITH RESPECT TO §15.407 (h) REQUIREMENTS

The Master Device is a Cisco Access Point, FCC ID: LDK102087. The minimum antenna gain for the Master Device is 6 dBi.

The rated output power of the Master unit is > 23dBm (EIRP). Therefore the required interference threshold level is -64 dBm. After correction for procedural adjustments, the required radiated threshold at the antenna port is $-64 + 1 = -63$ dBm.

The calibrated radiated DFS Detection Threshold level is set to -64 dBm. The tested level is lower than the required level hence it provides a margin to the limit.

14.2. RESULTS FOR 20 MHz BANDWIDTH

14.2.1. TEST CHANNEL

All tests were performed at a channel center frequency of 5500 MHz.

14.2.2. RADAR WAVEFORM AND TRAFFIC

RADAR WAVEFORM

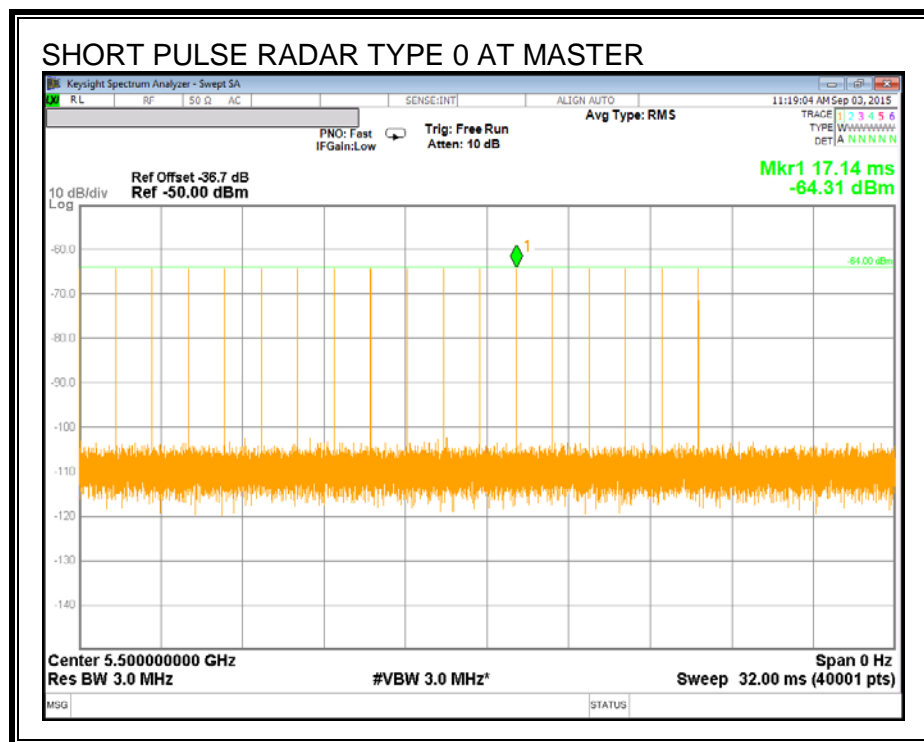

TRAFFIC

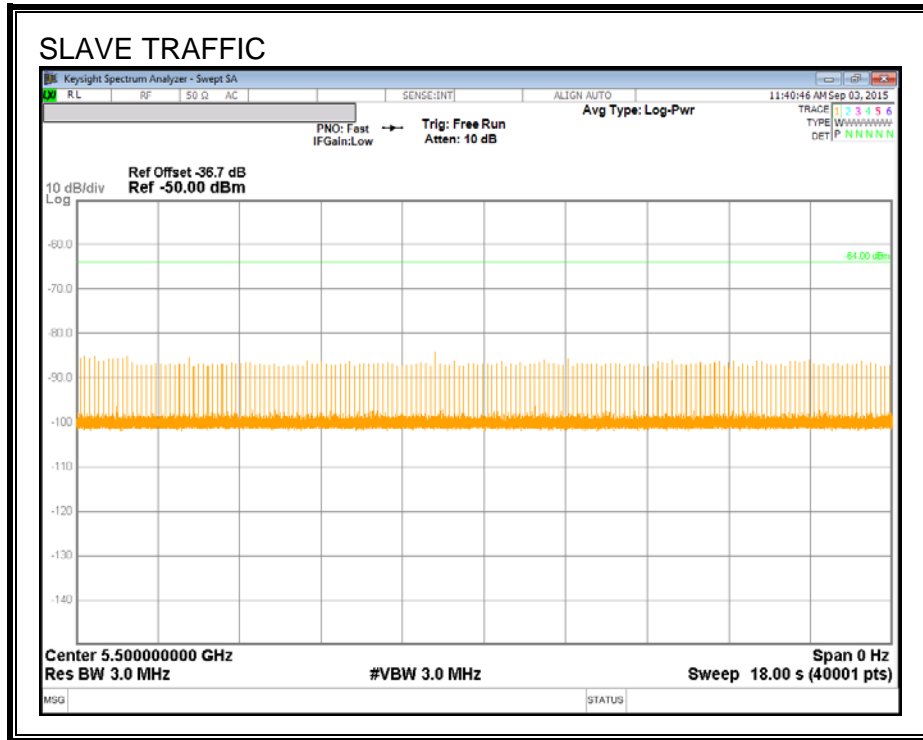

14.2.3. OVERLAPPING CHANNEL TESTS

RESULTS

These tests are not applicable.

14.2.4. MOVE AND CLOSING TIME

REPORTING NOTES

The reference marker is set at the end of last radar pulse.

The delta marker is set at the end of the last WLAN transmission following the radar pulse. This delta is the channel move time.

The aggregate channel closing transmission time is calculated as follows:

Aggregate Transmission Time =
(Number of analyzer bins showing transmission) * (dwell time per bin)

The observation period over which the aggregate time is calculated begins at (Reference Marker + 200 msec) and ends no earlier than (Reference Marker + 10 sec).

RESULTS

Channel Move Time (sec)	Limit (sec)
0.562	10

Aggregate Channel Closing Transmission Time (msec)	Limit (msec)
3.000	60

MOVE TIME & CHANNEL CLOSING TIME

AGGREGATE CHANNEL CLOSING TRANSMISSION TIME

No transmissions are observed during the aggregate monitoring period.

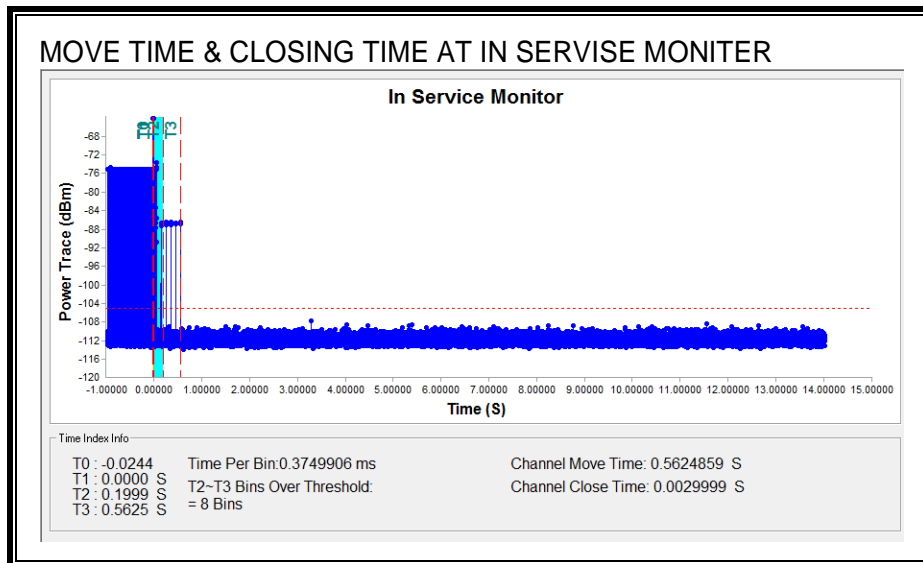
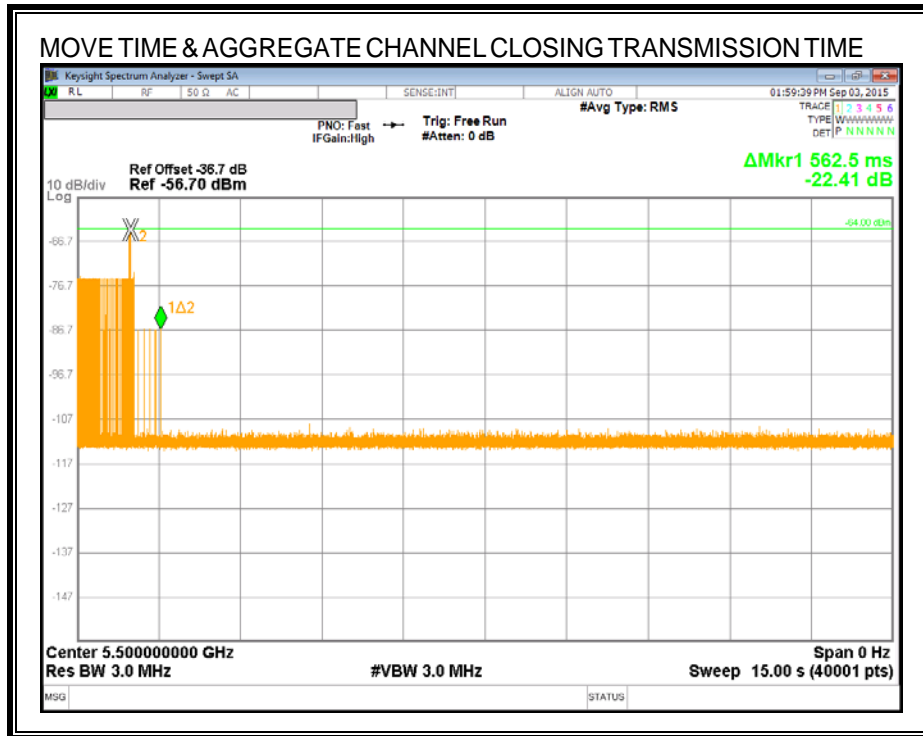

NON-OCCUPANCY PERIOD

RESULTS

No EUT transmissions were observed on the test channel during the 10-minute observation time.

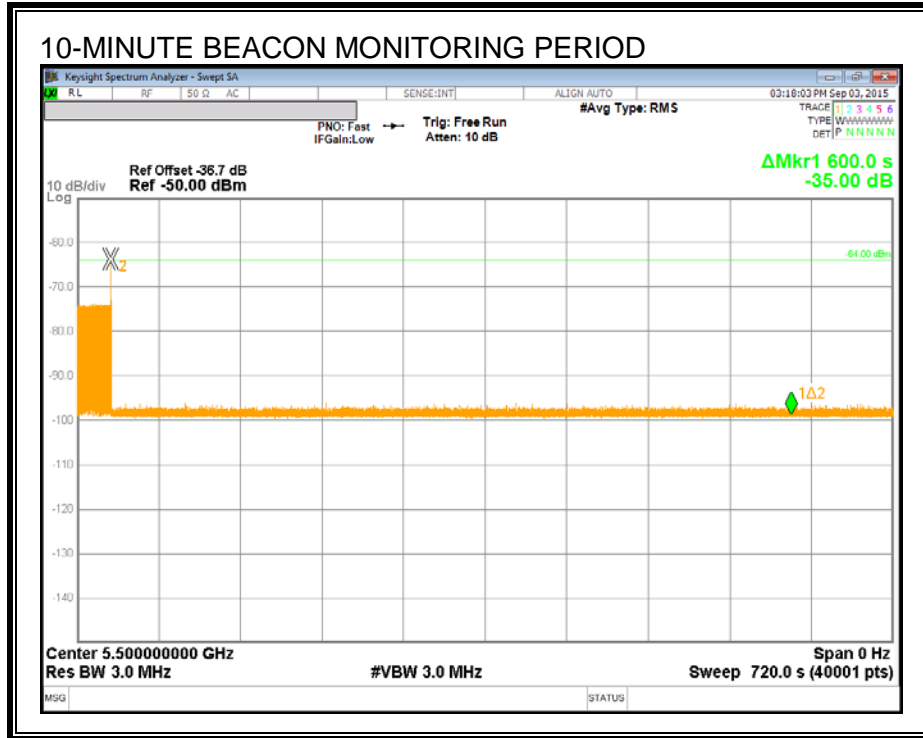

14.3. RESULTS FOR 40 MHz BANDWIDTH

14.3.1. TEST CHANNEL

All tests were performed at a channel center frequency of 5510 MHz.

14.3.2. RADAR WAVEFORM AND TRAFFIC

RADAR WAVEFORM

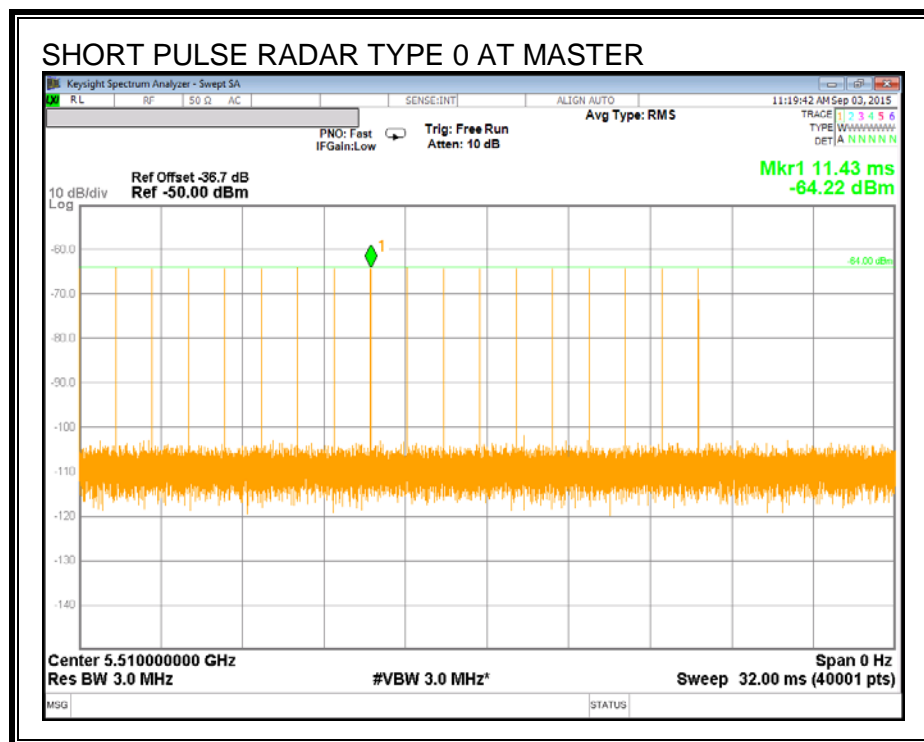

TRAFFIC

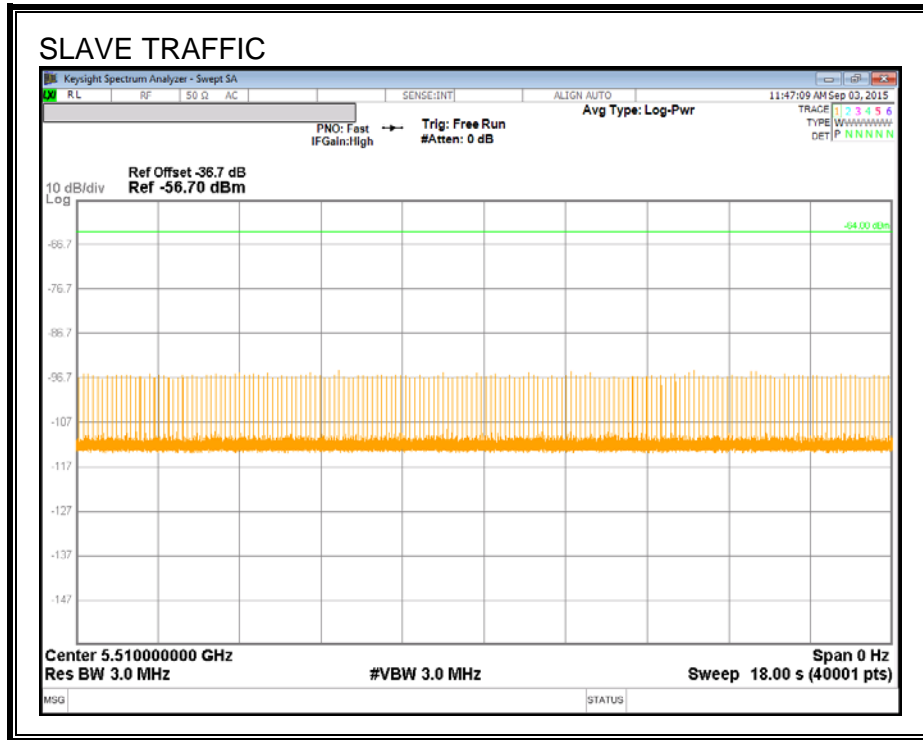

14.3.3. OVERLAPPING CHANNEL TESTS

RESULTS

These tests are not applicable.

14.3.4. MOVE AND CLOSING TIME

REPORTING NOTES

The reference marker is set at the end of last radar pulse.

The delta marker is set at the end of the last WLAN transmission following the radar pulse. This delta is the channel move time.

The aggregate channel closing transmission time is calculated as follows:

Aggregate Transmission Time =
(Number of analyzer bins showing transmission) * (dwell time per bin)

The observation period over which the aggregate time is calculated begins at (Reference Marker + 200 msec) and ends no earlier than (Reference Marker + 10 sec).

RESULTS

Channel Move Time (sec)	Limit (sec)
0.610	10

Aggregate Channel Closing Transmission Time (msec)	Limit (msec)
3.000	60

MOVE TIME & CHANNEL CLOSING TIME

AGGREGATE CHANNEL CLOSING TRANSMISSION TIME

No transmissions are observed during the aggregate monitoring period.

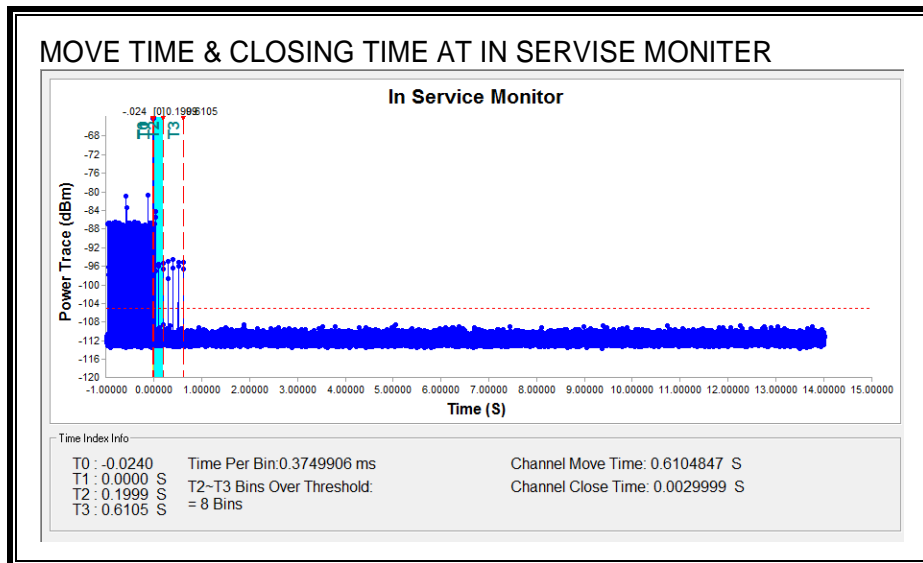
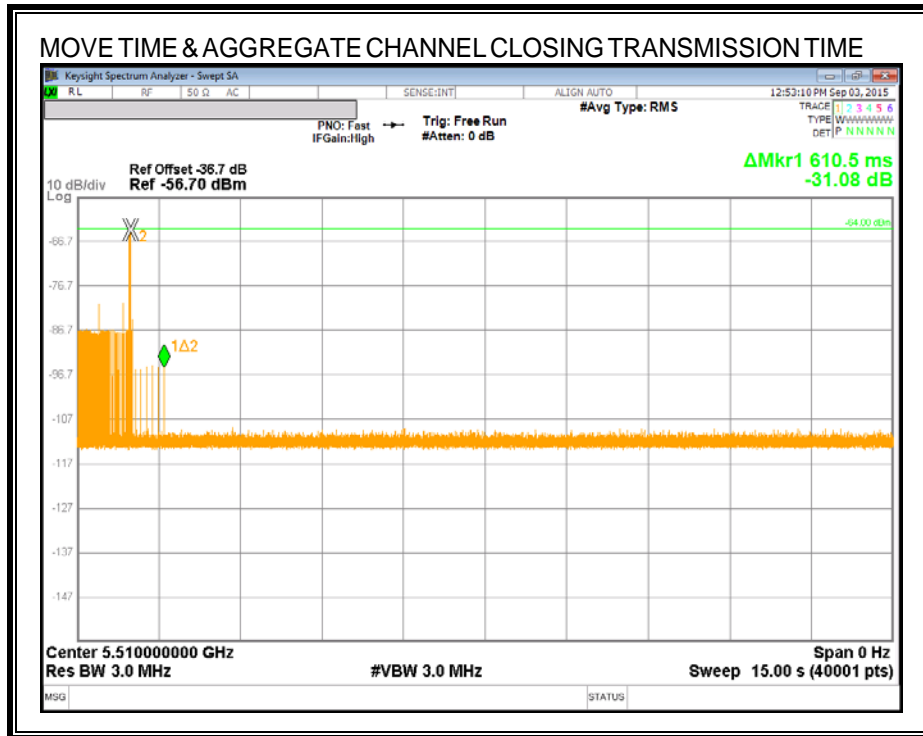

NON-OCCUPANCY PERIOD

RESULTS

No EUT transmissions were observed on the test channel during the 10-minute observation time.

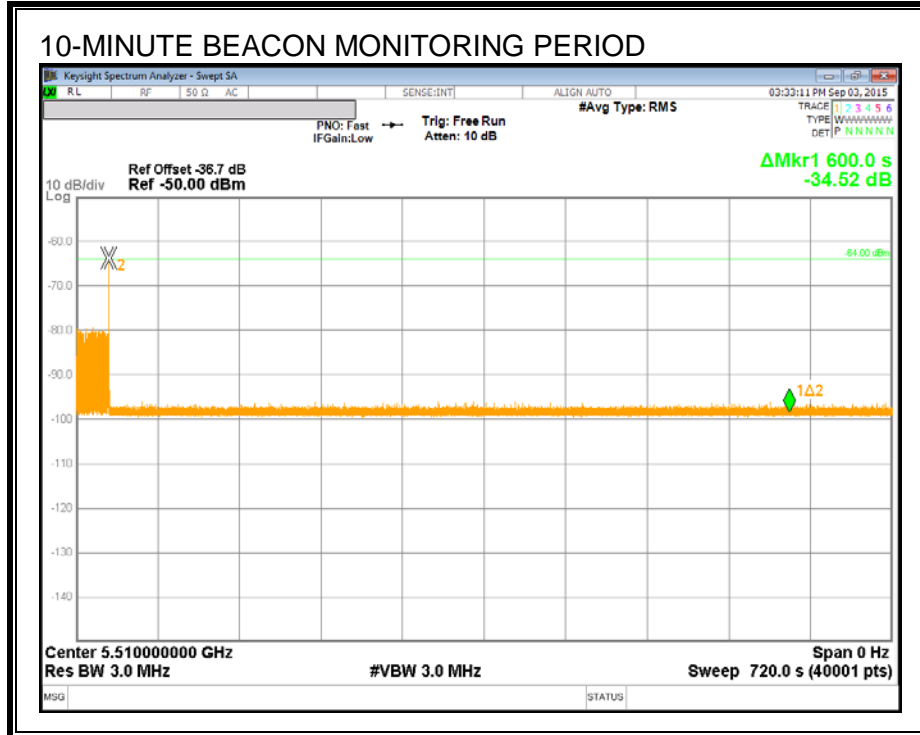

14.4. RESULTS FOR 80 MHz BANDWIDTH

14.4.1. TEST CHANNEL

All tests were performed at a channel center frequency of 5530 MHz.

14.4.2. RADAR WAVEFORM AND TRAFFIC

RADAR WAVEFORM

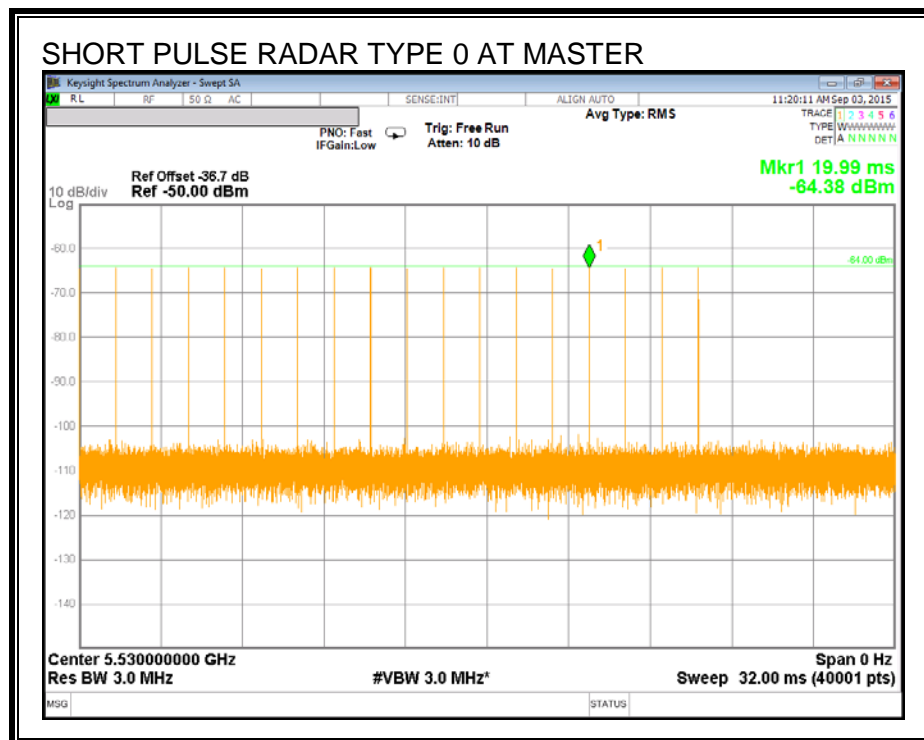

TRAFFIC

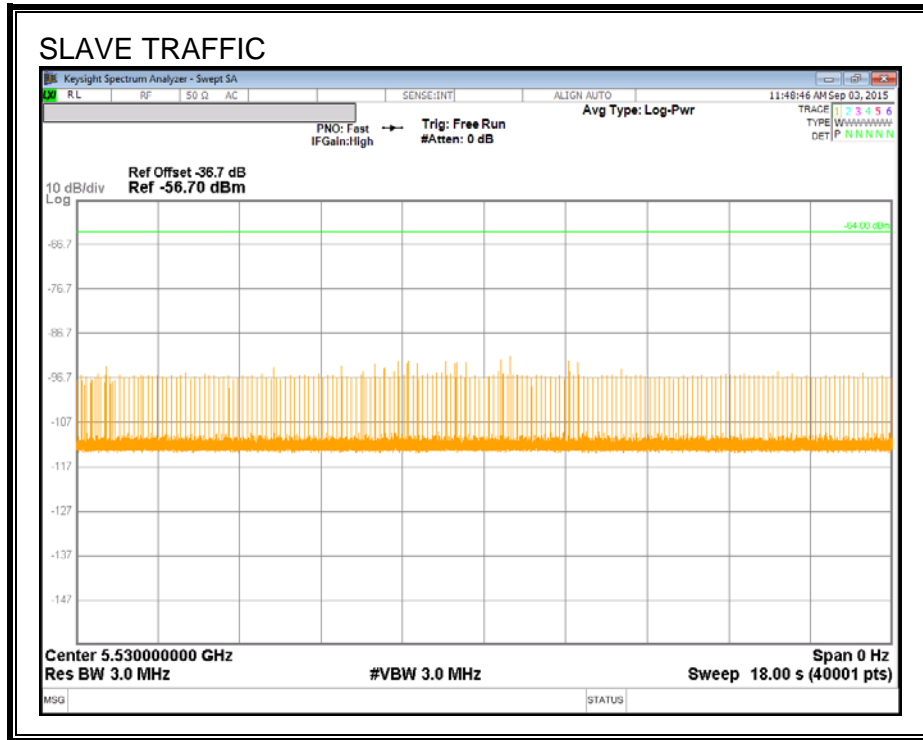

14.4.3. OVERLAPPING CHANNEL TESTS

RESULTS

These tests are not applicable.

14.4.4. MOVE AND CLOSING TIME

REPORTING NOTES

The reference marker is set at the end of last radar pulse.

The delta marker is set at the end of the last WLAN transmission following the radar pulse. This delta is the channel move time.

The aggregate channel closing transmission time is calculated as follows:

Aggregate Transmission Time =
(Number of analyzer bins showing transmission) * (dwell time per bin)

The observation period over which the aggregate time is calculated begins at (Reference Marker + 200 msec) and ends no earlier than (Reference Marker + 10 sec).

RESULTS

Channel Move Time (sec)	Limit (sec)
0.607	10

Aggregate Channel Closing Transmission Time (msec)	Limit (msec)
2.250	60

MOVE TIME & CHANNEL CLOSING TIME

AGGREGATE CHANNEL CLOSING TRANSMISSION TIME

No transmissions are observed during the aggregate monitoring period.

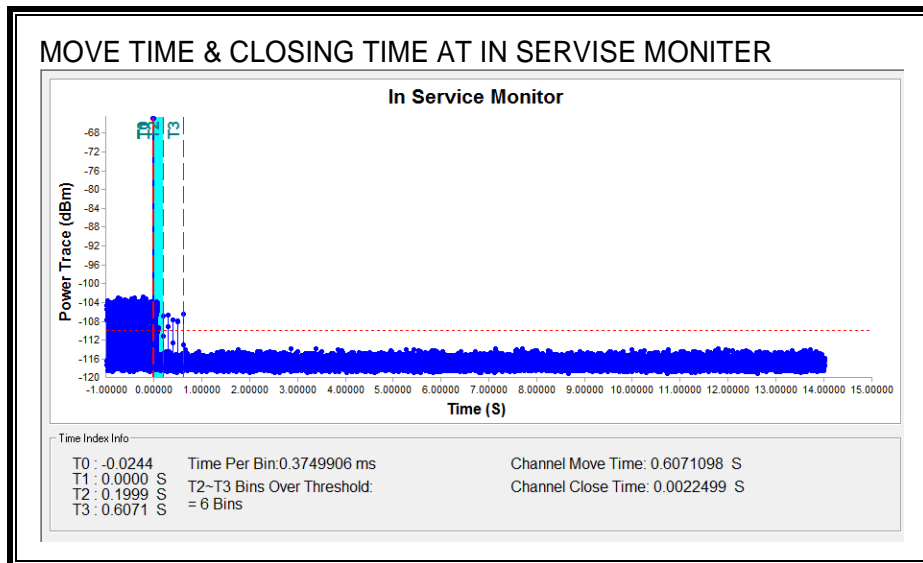
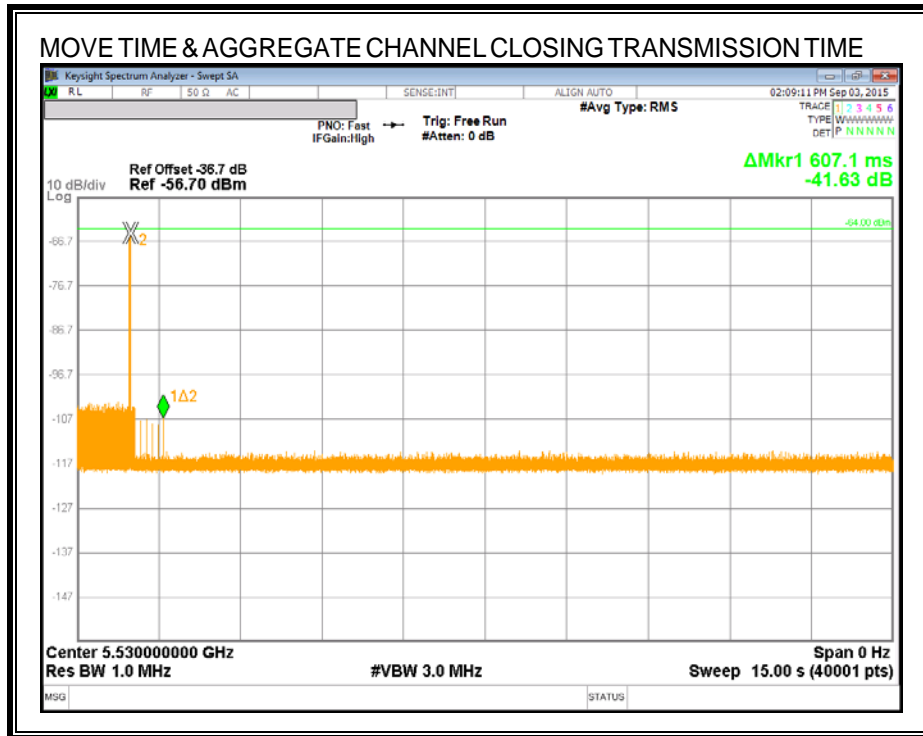

NON-OCCUPANCY PERIOD

RESULTS

No EUT transmissions were observed on the test channel during the 10-minute observation time.

