



CERTIFICATION TEST REPORT

Report Number. : 4790406759-E7V1

Applicant : SAMSUNG ELECTRONICS CO., LTD.
129 SAMSUNG-RO, YEONGTONG-GU, SUWON-SI,
GYEONGGI-DO, 16677, KOREA

Model : SM-T636B, SM-T638B

FCC ID : A3LSMT636B

EUT Description : GSM/WCDMA/LTE/5G NR Tablet + BT/BLE, DTS/UNII a/b/g/n/ac/ax
and NFC.

Test Standard(s) : FCC 47 CFR PART 15 SUBPART C

Date Of Issue:

2022-07-26

Prepared by:

UL Korea, Ltd.

26th floor, 152, Teheran-ro, Gangnam-gu Seoul, 06236, Korea

Suwon Test Site: UL Korea, Ltd. Suwon Laboratory

218 Maeyeong-ro, Yeongtong-gu,
Suwon-si, Gyeonggi-do, 16675, Korea

TEL: (031) 337-9902

FAX: (031) 213-5433



Revision History

| <u>Rev.</u> | <u>Issue Date</u> | <u>Revisions</u> | <u>Revised By</u> |
|-------------|-------------------|------------------|---------------------|
| V1 | 2022-07-26 | Initial issue | Dexter(Hyunsik) Yun |

TABLE OF CONTENTS

| | |
|---|-----------|
| 1. ATTESTATION OF TEST RESULTS | 4 |
| 2. TEST METHODOLOGY | 5 |
| 3. FACILITIES AND ACCREDITATION | 5 |
| 4. CALIBRATION AND UNCERTAINTY | 6 |
| 4.1. MEASURING INSTRUMENT CALIBRATION..... | 6 |
| 4.2. SAMPLE CALCULATION..... | 6 |
| 4.3. MEASUREMENT UNCERTAINTY | 6 |
| 4.4. DECISION RULE | 6 |
| 5. EQUIPMENT UNDER TEST..... | 7 |
| 5.1. DESCRIPTION OF EUT..... | 7 |
| 5.2. MAXIMUM E-FIELD STRENGTH..... | 7 |
| 5.3. WORST-CASE CONFIGURATION AND MODE | 7 |
| 5.4. DESCRIPTION OF TEST SETUP | 8 |
| 6. TEST AND MEASUREMENT EQUIPMENT | 10 |
| 7. 20dB BANDWIDTH | 11 |
| 8. RADIATED EMISSION TEST RESULTS..... | 12 |
| 8.1. LIMITS AND PROCEDURE | 12 |
| 8.1.1. FUNDAMENTAL AND SPURIOUS EMISSIONS (0.15 – 30 MHz) | 14 |
| 8.1.2. SPURIOUS EMISSION 0.009 TO 30 MHz..... | 15 |
| 8.1.3. TX SPURIOUS EMISSION 30 TO 1000 MHz | 16 |
| 8.1.4. FUNDAMENTAL AND SPURIOUS EMISSIONS (0.15 – 30 MHz) [EUT with passive TAG mode] | 17 |
| 8.1.5. SPURIOUS EMISSION 0.09 TO 30 MHz [EUT with passive TAG mode]..... | 18 |
| 8.1.6. TX SPURIOUS EMISSION 30 TO 1000 MHz [EUT with passive TAG mode] | 19 |
| 9. AC MAINS LINE CONDUCTED EMISSIONS..... | 20 |
| 9.1.1. AC Power Line (C to C) | 21 |
| 9.1.2. AC Power Line (A to C)..... | 25 |
| 10. FREQUENCY STABILITY | 29 |

1. ATTESTATION OF TEST RESULTS

COMPANY NAME: SAMSUNG ELECTRONICS CO., LTD.
EUT DESCRIPTION: GSM/WCDMA/LTE/5G NR Tablet + BT/BLE, DTS/UNII a/b/g/n/ac/ax and NFC
MODEL NUMBER: SM-T636B, SM-T638B
SERIAL NUMBER: R32T5002ZQH, R32T5004ZEX (RADIATED);
DATE TESTED: 2022-06-06 ~ 2022-07-26

| APPLICABLE STANDARDS | |
|--------------------------|--------------|
| STANDARD | TEST RESULTS |
| CFR 47 Part 15 Subpart C | Pass |

UL Korea, Ltd. tested the above equipment in accordance with the requirements set forth in the above standards. All indications of Pass/Fail in this report are opinions expressed by UL Korea, Ltd. based on interpretations and/or observations of test results. Measurement Uncertainties were not taken into account and are published for informational purposes only. The test results show that the equipment tested is capable of demonstrating compliance with the requirements as documented in this report.

Note: The results documented in this report apply only to the tested sample, under the conditions and modes of operation as described herein. This document may not be altered or revised in any way unless done so by UL Korea, Ltd. and all revisions are duly noted in the revisions section. Any alteration of this document not carried out by UL Korea, Ltd. will constitute fraud and shall nullify the document. This report must not be used by the client to claim product certification, approval, or endorsement by IAS, any agency of the Federal Government, or any agency of any government.

Approved & Released For
UL Korea, Ltd. By:



Seokhwan Hong
Suwon Lab Engineer
UL Korea, Ltd.

Tested By:



Dexter(Hyunsik) Yun
Suwon Lab Engineer
UL Korea, Ltd.

2. TEST METHODOLOGY

The tests documented in this report were performed in accordance with following methods.

1. FCC CFR 47 Part 2.
2. FCC CFR 47 Part 15.
3. ANSI C63.10-2013.
4. KDB 414788 D01 Radiated Test Site v01r01

3. FACILITIES AND ACCREDITATION

The test sites and measurement facilities used to collect data are located at 218 Maeyeong-ro, Yeongtong-gu, Suwon-si, Gyeonggi-do, 16675, Korea. Line conducted emissions are measured only at the 218 address. The following table identifies which facilities were utilized for radiated emission measurements documented in this report. Specific facilities are also identified in the test results sections.

| 218 Maeyeong-ro | |
|-------------------------------------|-------------------------------------|
| <input checked="" type="checkbox"/> | Chamber 1(3m semi-anechoic chamber) |
| <input checked="" type="checkbox"/> | Chamber 2(3m semi-anechoic chamber) |
| <input type="checkbox"/> | Chamber 3(3m semi-anechoic chamber) |
| <input type="checkbox"/> | Chamber 4(3m Full-anechoic chamber) |
| <input type="checkbox"/> | Chamber 5(3m Full-anechoic chamber) |

UL Korea, Ltd. is accredited by IAS, Laboratory Code TL-637. The full scope of accreditation can be viewed at <https://www.iasonline.org/wp-content/uploads/2017/05/TL-637-cert-New.pdf>.

4. CALIBRATION AND UNCERTAINTY

4.1. MEASURING INSTRUMENT CALIBRATION

The measuring equipment utilized to perform the tests documented in this report has been calibrated in accordance with the manufacturer's recommendations, and is traceable to recognized national standards.

4.2. SAMPLE CALCULATION

Where relevant, the following sample calculation is provided:

$$\begin{aligned} \text{Field Strength (dBuV/m)} &= \text{Measured Voltage (dBuV)} + \text{Antenna Factor (dB/m)} + \\ &\text{Cable Loss (dB)} - \text{Preamp Gain (dB)} \\ 36.5 \text{ dBuV} + 18.7 \text{ dB/m} + 0.6 \text{ dB} - 26.9 \text{ dB} &= 28.9 \text{ dBuV/m} \end{aligned}$$

4.3. MEASUREMENT UNCERTAINTY

Where relevant, the following measurement uncertainty levels have been estimated for tests performed on the apparatus:

| PARAMETER | UNCERTAINTY |
|---------------------------------------|-------------|
| Conducted Disturbance, 0.15 to 30 MHz | 3.02 dB |
| Radiated Disturbance, 9 kHz to 30 MHz | 1.72 dB |
| Radiated Disturbance, 30 MHz to 1 GHz | 4.05 dB |

Uncertainty figures are valid to a confidence level of 95%.

4.4. DECISION RULE

Decision rule for statement(s) of conformity is based on Procedure 2, Clause 4.4.3 in IEC Guide 115:2007.

5. EQUIPMENT UNDER TEST

5.1. DESCRIPTION OF EUT

The EUT is a GSM/WCDMA/LTE/5G NR Tablet + BT/BLE, DTS/UNII a/b/g/n/ac/ax and NFC. This test report addresses the DXX (NFC) operational mode.

SM-T638B model is same hardware thus, SM-T636B was set for final test.

5.2. MAXIMUM E-FIELD STRENGTH

The testing was performed at 3 meter. The transmitter maximum E-field at 30m distance is 23.10 dBuV/m which convert from 3 meter data.

5.3. WORST-CASE CONFIGURATION AND MODE

The NFC function was tested at its' fundamental and only operational frequency of 13.56 MHz.

The NFC with tag mode's fundamental of the EUT was investigated in three orthogonal orientations X, Y and Z. It was determined that the Y orientation was the worst-case orientation; therefore all final radiated testing was performed with the EUT in the Y orientation while generating continuous emissions.

The NFC without tag mode's fundamental of the EUT was investigated in three orthogonal orientations X, Y and Z. It was determined that the Y orientation was the worst-case orientation; therefore all final radiated testing was performed with the EUT in the Y orientation while generating continuous emissions.

The fundamental level of the EUT was investigated each type and bitrate. All test was performed worst case condition(type A and bit rate 106 kbps).

Radiated(fundamental level and spurious emissions) tests were performed both without reading a passive tag condition[test mode] and with reading a passive tag condition.

5.4. DESCRIPTION OF TEST SETUP

SUPPORT EQUIPMENT

| Support Equipment List | | | | |
|------------------------|--------------|-------------|----------------|--------|
| Description | Manufacturer | Model | Serial Number | FCC ID |
| Charger | SAMSUNG | EP-TA200 | R37N6K421B2SE3 | N/A |
| Data Cable | SAMSUNG | EP-DT725BWE | GH39-02020A | N/A |
| Charger | SAMSUNG | EP-TA800 | R37N3MAH988DK3 | N/A |
| Data Cable | SAMSUNG | EP-DN980 | GH39-02115A | N/A |
| Earphone | SAMSUNG | GH59-15055A | EHS64AVFWE | N/A |

I/O CABLE

| I/O Cable List | | | | | | |
|----------------|----------|----------------------|----------------|------------|------------------|---------|
| Cable No. | Port | # of identical ports | Connector Type | Cable Type | Cable Length (m) | Remarks |
| 1 | DC Power | 1 | A to C Type | Shielded | 1.0 m | N/A |
| 2 | DC Power | 1 | C to C Type | Shielded | 1.0 m | N/A |
| 3 | Audio | 2 | Mini-Jack | Unshielded | 0.7 m | N/A |

The EUT is a stand-alone device configured and tested in a worst-case setup.

Note: Worst case is using worst case orientation with AC charger attached to the EUT with NFC signal continuously transmitting.

SETUP DIAGRAM FOR TESTS (RADIATED TEST SETUP)

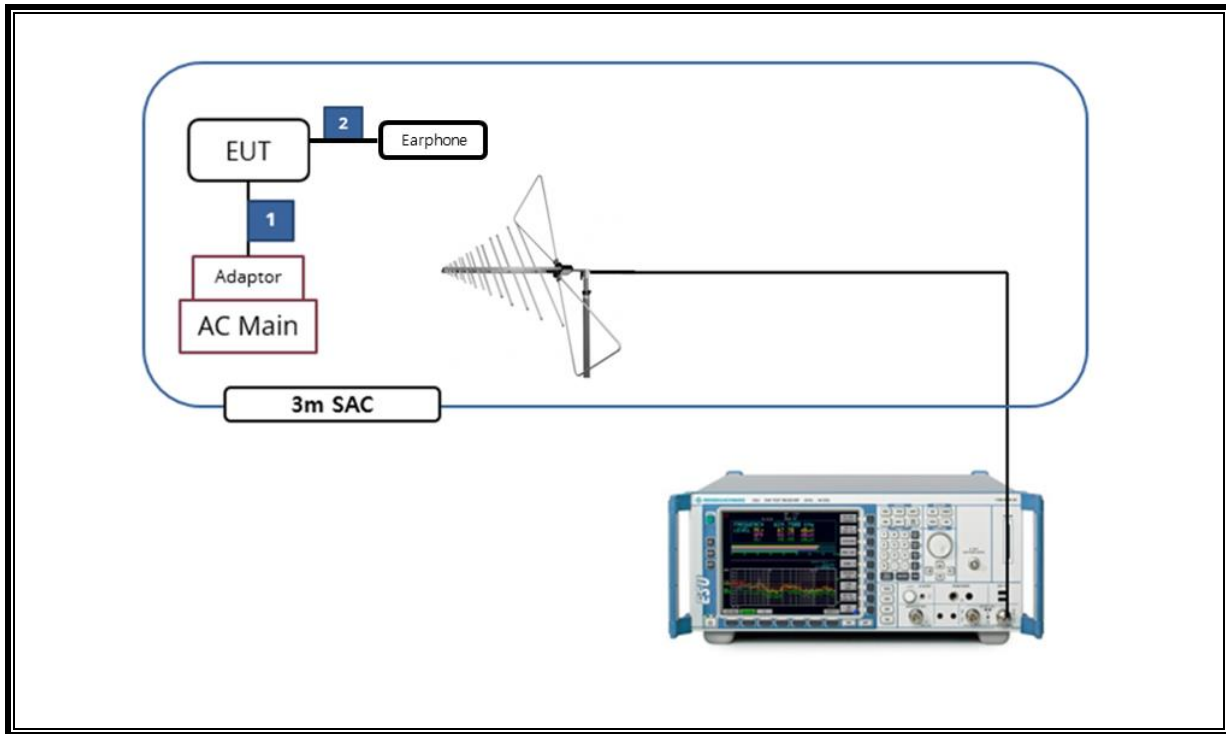

6. TEST AND MEASUREMENT EQUIPMENT

The following test and measurement equipment was utilized for the tests documented in this report:

| Test Equipment List | | | | |
|----------------------------|--------------|----------|------------|------------|
| Description | Manufacturer | Model | S/N | Cal Due |
| Antenna, Bilog, 30MHz-1GHz | SCHWARZBECK | VULB9163 | 845 | 2022-08-13 |
| Antenna, Bilog, 30MHz-1GHz | SCHWARZBECK | VULB9163 | 749 | 2022-08-13 |
| Preamplifier, 1000 MHz | Sonoma | 310N | 341282 | 2022-08-02 |
| Preamplifier, 1000 MHz | Sonoma | 310N | 351741 | 2022-08-02 |
| Spectrum Analyzer, 7 GHz | Agilent / HP | N9010A | MY54200580 | 2022-08-02 |
| EMI Test Receive, 3 GHz | R&S | ESR3 | 101832 | 2022-08-02 |
| DC Power Supply | Agilent / HP | E3640A | MY54226395 | 2022-08-02 |
| Temperature Chamber | ESPEC | SH-642 | 93001109 | 2022-08-02 |
| LISN | R&S | ENV216 | 101837 | 2022-08-05 |
| Antenna, Loop, 9kHz-30MHz | R&S | HFH2-Z2 | 100418 | 2023-10-06 |
| UL Software | | | | |
| Description | Manufacturer | Model | Version | |
| Radiated software | UL | UL EMC | Ver 9.5 | |
| AC Line Conducted software | UL | UL EMC | Ver 9.5 | |

7. 20dB BANDWIDTH

LIMITS

§15.215

(c) Intentional radiators operating under the alternative provisions to the general emission limits, as contained in §§15.217 through 15.257 and in subpart E of this part, must be designed to ensure that the 20 dB bandwidth of the emission, or whatever bandwidth may otherwise be specified in the specific rule section under which the equipment operates, is contained within the frequency band designated in the rule section under which the equipment is operated

§15.225

Operation within the band 13.110 – 14.010MHz

TEST PROCEDURE

The spectrum analyzer connected receive antenna and the EUT placed on near the receive antenna. The RBW is set to 10kHz. The VBW is set to 3 times the RBW. The sweep time is coupled.

RESULTS

| Frequency [MHz] | 20 dB Bandwidth [kHz] |
|-----------------|-----------------------|
| 13.56 | 437.00 |

20dB Bandwidth Plot



8. RADIATED EMISSION TEST RESULTS

8.1. LIMITS AND PROCEDURE

LIMIT

§15.225

(a) The field strength of any emissions within the band 13.553–13.567 MHz shall not exceed 15,848 microvolts/ meter at 30 meters.

(b) Within the bands 13.410–13.553 MHz and 13.567–13.710 MHz, the field strength of any emissions shall not exceed 334 microvolts/meter at 30 meters.

(c) Within the bands 13.110–13.410 MHz and 13.710–14.010 MHz the field strength of any emissions shall not exceed 106 microvolts/meter at 30 meters.

(d) The field strength of any emissions appearing outside of the 13.110– 14.010 MHz and shall not exceed the general radiated emission limits in § 15.209 as follows:

§15.209 (a) Except as provided elsewhere in this subpart, the emissions from an intentional radiator shall not exceed the field strength levels specified in the following table:

| Limits for radiated disturbance of an intentional radiator | | |
|--|-----------------|--------------------------|
| Frequency range (MHz) | Limits (µV/m) | Measurement Distance (m) |
| 0.009 – 0.490 | 2400 / F (kHz) | 300 |
| 0.490 – 1.705 | 24000 / F (kHz) | 30 |
| 1.705 – 30.0 | 30 | 30 |
| 30 – 88 | 100** | 3 |
| 88 - 216 | 150** | 3 |
| 216 – 960 | 200** | 3 |
| Above 960 | 500 | 3 |

** Except as provided in paragraph (g), fundamental emissions from intentional radiators operating under this section shall not be located in the frequency bands 54-72 MHz, 76-88 MHz, 174-216 MHz or 470-806 MHz. However, operation within these frequency bands is permitted under other sections of this part, e.g. §§ 15.231 and 15.241.

§15.209 (b) In the emission table above, the tighter limit applies at the band edges.

Formula for converting the filed strength from uV/m to dBuV/m is:

Limit (dBuV/m) = 20 log limit (uV/m)

In addition:

§15.209 (d) The emission limits shown the above table are based on measurements employing a CISPR quasi-peak detector except for the frequency bands 9-90 kHz, 110-490 kHz and above 1000 MHz. Radiated emissions limits in these three bands are based on measurements employing an average detector.

§15.209 (d) The provisions in §§ 15.225, measuring emissions at distances other than the distances specified in the above table, determining the frequency range over which radiated emissions are to be measured, and limiting peak emissions apply to all devices operated under this part.

TEST PROCEDURE

ANSI C63.10-2013

The EUT is an intentional radiator that incorporates a digital device. The highest fundamental frequency generated or used in the device is 13.56 MHz. The frequency range was investigated from 0.15 MHz to the 10th harmonic of the highest fundamental frequency, or 1000 MHz, whichever is greater (1000MHz)

RESULTS

No non-compliance noted:

8.1.1. FUNDAMENTAL AND SPURIOUS EMISSIONS (0.15 – 30 MHz) [EUT without passive TAG mode]

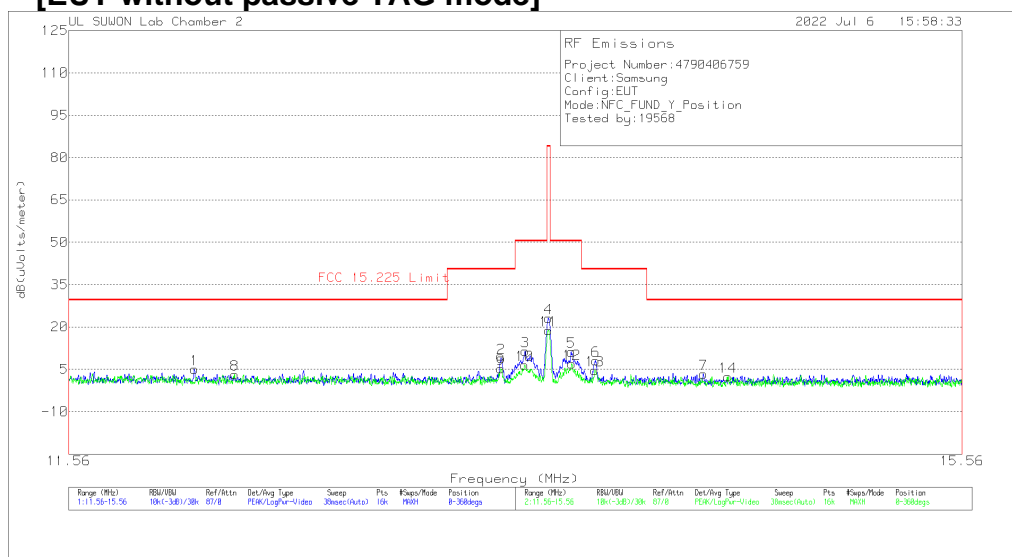

Trace Markers Face on

| Marker | Frequency (MHz) | Meter Reading (dBuV) | Det | HFH2-Z2_Loop Antenna | Dist Corr 30m | Cable Loss | Corrected Reading dB(uVolts/meter) | FCC 15.225 Limit | Margin (dB) | Azimuth (Degs) |
|--------|-----------------|----------------------|-----|----------------------|---------------|------------|------------------------------------|------------------|-------------|----------------|
| 1 | 12.05325 | 24.53 | Pk | 20 | -40 | .5 | 5.03 | 29.54 | -24.51 | 0-360 |
| 2 | 13.34838 | 28.58 | Pk | 20 | -40 | .5 | 9.08 | 40.51 | -31.43 | 0-360 |
| 3 | 13.45513 | 30.97 | Pk | 20 | -40 | .5 | 11.47 | 50.5 | -39.03 | 0-360 |
| **4 | 13.55988 | 42.6 | Pk | 20 | -40 | .5 | 23.1 | 84 | -60.9 | 0-360 |
| 5 | 13.66288 | 30.58 | Pk | 20 | -40 | .6 | 11.18 | 50.5 | -39.32 | 0-360 |
| 6 | 13.77488 | 27.41 | Pk | 20 | -40 | .6 | 8.01 | 40.51 | -32.5 | 0-360 |
| 7 | 14.27663 | 22.84 | Pk | 20 | -40 | .6 | 3.44 | 29.54 | -26.1 | 0-360 |

Face off

| Marker | Frequency (MHz) | Meter Reading (dBuV) | Det | HFH2-Z2_Loop Antenna | Dist Corr 30m | Cable Loss | Corrected Reading dB(uVolts/meter) | FCC 15.225 Limit | Margin (dB) | Azimuth (Degs) |
|--------|-----------------|----------------------|-----|----------------------|---------------|------------|------------------------------------|------------------|-------------|----------------|
| 8 | 12.21575 | 22.6 | Pk | 20 | -40 | .5 | 3.1 | 29.54 | -26.44 | 0-360 |
| 9 | 13.34663 | 24.68 | Pk | 20 | -40 | .5 | 5.18 | 40.51 | -35.33 | 0-360 |
| 10 | 13.45338 | 25.98 | Pk | 20 | -40 | .5 | 6.48 | 50.5 | -44.02 | 0-360 |
| **11 | 13.56025 | 38.39 | Pk | 20 | -40 | .5 | 18.89 | 84 | -65.11 | 0-360 |
| 12 | 13.66563 | 26.34 | Pk | 20 | -40 | .6 | 6.94 | 50.5 | -43.56 | 0-360 |
| 13 | 13.77138 | 24.09 | Pk | 20 | -40 | .6 | 4.69 | 40.51 | -35.82 | 0-360 |
| 14 | 14.39538 | 21.84 | Pk | 20 | -40 | .6 | 2.44 | 29.54 | -27.1 | 0-360 |

Pk - Peak detector
 **Fundamental

Note 1 : Although these tests were performed other than open filed test site, adequate comparison measurements were confirmed against 30 m open are test site. Therefore sufficient tests were made to demonstrate that the alternative site produces results that correlate with the ones of tests made in an open field based on KDB 414788.

Note 2: Radiated test were investigated with three receiving antenna axes: Face-on, Face-off and horizontal (parallel to the ground plane) and the worse orientations of Face-on and Face-off were set for final test.

8.1.2. SPURIOUS EMISSION 0.009 TO 30 MHz

[EUT without passive TAG mode]

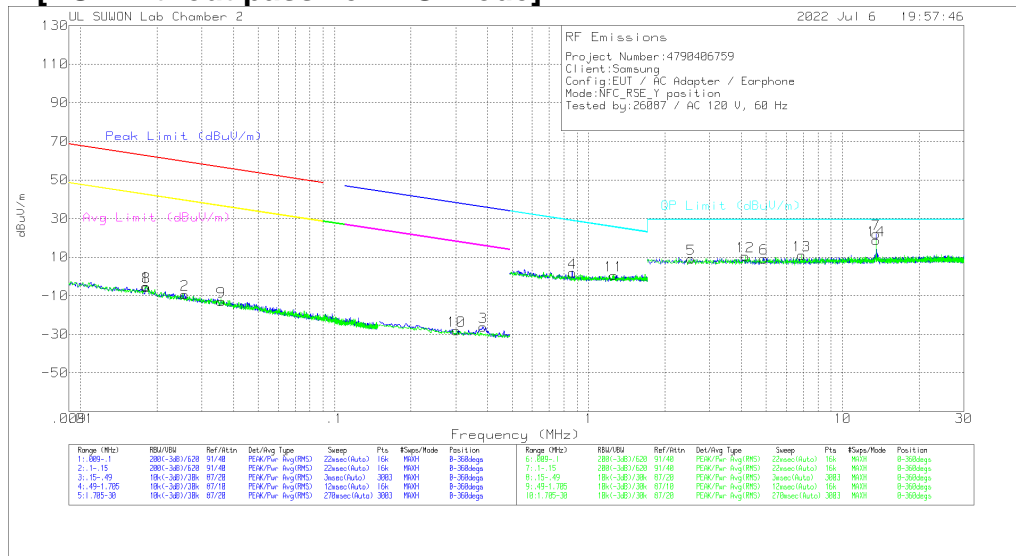

Trace Markers

Face on

| Marker | Frequency (MHz) | Meter Reading (dBuV) | Det | HFH2-Z2_Loop Antenna | Cable Loss | Dist Corr 300m | Corrected Reading dBuV/m | Peak Limit (dBuV/m) | Margin (dB) | Avg Limit (dBuV/m) | Margin (dB) | Azimuth (Degs) |
|--------|-----------------|----------------------|-----|----------------------|------------|----------------|--------------------------|---------------------|-------------|--------------------|-------------|----------------|
| 1 | .01813 | 54.6 | Pk | 20.2 | .1 | -80 | -5.1 | 62.42 | -67.52 | 42.42 | -47.52 | 0-360 |
| 2 | .02567 | 50.45 | Pk | 20.1 | .1 | -80 | -9.35 | 59.39 | -68.74 | 39.39 | -48.74 | 0-360 |
| 3 | .38448 | 33.96 | Pk | 19.7 | .1 | -80 | -26.24 | 35.91 | -62.15 | 15.91 | -42.15 | 0-360 |

| Marker | Frequency (MHz) | Meter Reading (dBuV) | Det | HFH2-Z2_Loop Antenna | Cable Loss | Dist Corr 30m | Corrected Reading dBuV/m | QP Limit (dBuV/m) | Margin (dB) | Azimuth (Degs) |
|--------|-----------------|----------------------|-----|----------------------|------------|---------------|--------------------------|-------------------|-------------|----------------|
| 4 | .86316 | 22.04 | Pk | 19.8 | .2 | -40 | 2.04 | 28.9 | -26.86 | 0-360 |
| 5 | 2.5344 | 28.92 | Pk | 19.9 | .3 | -40 | 9.12 | 29.5 | -20.38 | 0-360 |
| 6 | 4.90008 | 29.14 | Pk | 19.8 | .3 | -40 | 9.24 | 29.5 | -20.26 | 0-360 |
| **7 | 13.56165 | 41.53 | Pk | 20 | .5 | -40 | 22.03 | 29.5 | -7.47 | 0-360 |

Face off

| Marker | Frequency (MHz) | Meter Reading (dBuV) | Det | HFH2-Z2_Loop Antenna | Cable Loss | Dist Corr 300m | Corrected Reading dBuV/m | Peak Limit (dBuV/m) | Margin (dB) | Avg Limit (dBuV/m) | Margin (dB) | Azimuth (Degs) |
|--------|-----------------|----------------------|-----|----------------------|------------|----------------|--------------------------|---------------------|-------------|--------------------|-------------|----------------|
| 8 | .01814 | 54.32 | Pk | 20.2 | .1 | -80 | -5.38 | 62.41 | -67.79 | 42.41 | -47.79 | 0-360 |
| 9 | .03579 | 46.94 | Pk | 20 | .1 | -80 | -12.96 | 56.51 | -69.47 | 36.51 | -49.47 | 0-360 |
| 10 | .30244 | 32.18 | Pk | 19.7 | .1 | -80 | -28.02 | 38 | -66.02 | 18 | -46.02 | 0-360 |

| Marker | Frequency (MHz) | Meter Reading (dBuV) | Det | HFH2-Z2_Loop Antenna | Cable Loss | Dist Corr 30m | Corrected Reading dBuV/m | QP Limit (dBuV/m) | Margin (dB) | Azimuth (Degs) |
|--------|-----------------|----------------------|-----|----------------------|------------|---------------|--------------------------|-------------------|-------------|----------------|
| 11 | 1.25502 | 20.67 | Pk | 19.8 | .2 | -40 | .67 | 25.65 | -24.98 | 0-360 |
| 12 | 4.14608 | 30.35 | Pk | 19.8 | .3 | -40 | 10.45 | 29.5 | -19.05 | 0-360 |
| 13 | 6.89818 | 30.83 | Pk | 19.9 | .4 | -40 | 11.13 | 29.5 | -18.37 | 0-360 |
| **14 | 13.56165 | 38.31 | Pk | 20 | .5 | -40 | 18.81 | 29.5 | -10.69 | 0-360 |

Pk - Peak detector

**Fundamental

Note 1: The data for marker number 7 and 14 are the fundamental signal.

Please refer to section 8.1.1 about the fundamental level.

Frequency range 0.009MHz ~ 0.490MHz, only noise floor level and more than 20dB margin.

Note 2: Radiated test were investigated with three receiving antenna axes: Face-on, Face-off and horizontal (parallel to the ground plane) and the worse orientations of Face-on and Face-off were set for final test.

8.1.3. TX SPURIOUS EMISSION 30 TO 1000 MHz [EUT without passive TAG mode]

HORIZONTAL

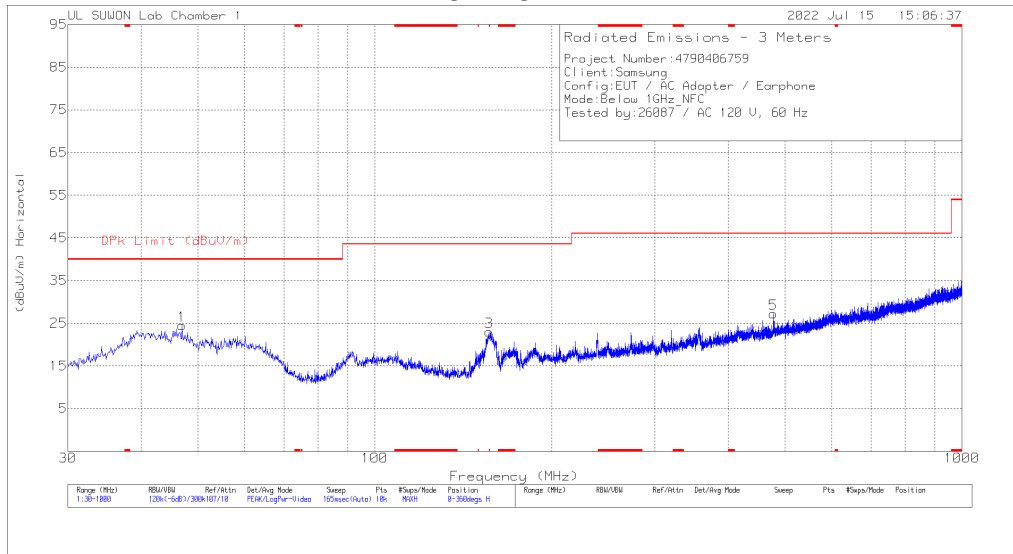

VERTICAL

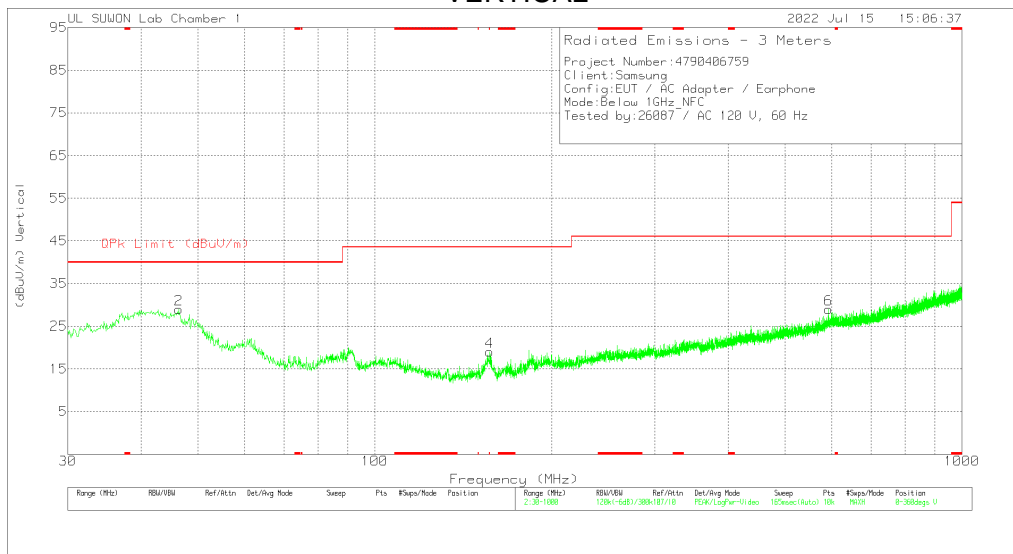

Trace Markers

| Marker | Frequency (MHz) | Meter Reading (dBuV) | Det | VULB9163_750 | Below_1G[dB] | Corrected Reading (dBuV/m) | QPk Limit (dBuV/m) | Margin (dB) | Azimuth (Degs) | Height (cm) | Polarity |
|--------|-----------------|----------------------|-----|--------------|--------------|----------------------------|--------------------|-------------|----------------|-------------|----------|
| 1 | 46.975 | 35.44 | Pk | 19.9 | -30.9 | 24.44 | 40 | -15.56 | 0-360 | 300 | H |
| 3 | 156.488 | 38.58 | Pk | 14.1 | -29.7 | 22.98 | 43.52 | -20.54 | 0-360 | 100 | H |
| 5 | 477.073 | 32.28 | Pk | 22.6 | -27.7 | 27.18 | 46.02 | -18.84 | 0-360 | 100 | H |
| 2 | 46.393 | 40.12 | Pk | 19.9 | -31 | 29.02 | 40 | -10.98 | 0-360 | 200 | V |
| 4 | * 156.876 | 34.38 | Pk | 14.2 | -29.6 | 18.98 | 43.52 | -24.54 | 0-360 | 200 | V |
| 6 | 592.988 | 31.05 | Pk | 25.2 | -27.3 | 28.95 | 46.02 | -17.07 | 0-360 | 300 | V |

* - indicates frequency in CFR47 Pt 15 / IC RSS-Restricted Band
 Pk - Peak detector

8.1.4. FUNDAMENTAL AND SPURIOUS EMISSIONS (0.15 – 30 MHz) [EUT with passive TAG mode]

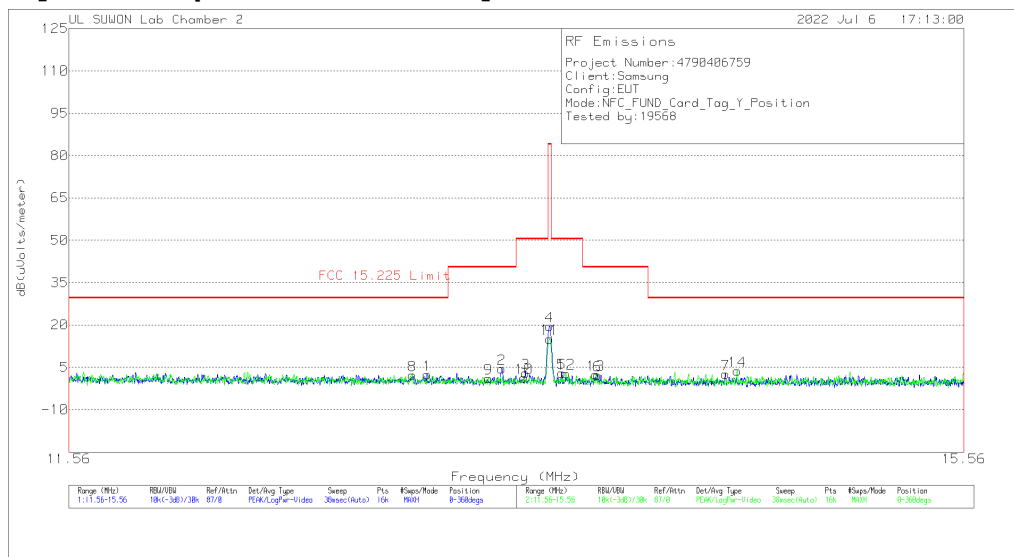

Trace Markers Face on

| Marker | Frequency (MHz) | Meter Reading (dBuV) | Det | HFH2-Z2_Loop Antenna | Dist Corr 30m | Cable Loss | Corrected Reading dB(uVolts/meter) | FCC 15.225 Limit | Margin (dB) | Azimuth (Degs) |
|--------|-----------------|----------------------|-----|----------------------|---------------|------------|------------------------------------|------------------|-------------|----------------|
| 1 | 13.02125 | 21.96 | Pk | 20 | -40 | .5 | 2.46 | 29.54 | -27.08 | 0-360 |
| 2 | 13.3475 | 23.99 | Pk | 20 | -40 | .5 | 4.49 | 40.51 | -36.02 | 0-360 |
| 3 | 13.45325 | 22.55 | Pk | 20 | -40 | .5 | 3.05 | 50.5 | -47.45 | 0-360 |
| **4 | 13.5605 | 39.11 | Pk | 20 | -40 | .5 | 19.61 | 84 | -64.39 | 0-360 |
| 5 | 13.61575 | 22.41 | Pk | 20 | -40 | .6 | 3.01 | 50.5 | -47.49 | 0-360 |
| 6 | 13.77675 | 21.55 | Pk | 20 | -40 | .6 | 2.15 | 40.51 | -38.36 | 0-360 |
| 7 | 14.37575 | 22 | Pk | 20 | -40 | .6 | 2.6 | 29.54 | -26.94 | 0-360 |

Face off

| Marker | Frequency (MHz) | Meter Reading (dBuV) | Det | HFH2-Z2_Loop Antenna | Dist Corr 30m | Cable Loss | Corrected Reading dB(uVolts/meter) | FCC 15.225 Limit | Margin (dB) | Azimuth (Degs) |
|--------|-----------------|----------------------|-----|----------------------|---------------|------------|------------------------------------|------------------|-------------|----------------|
| 8 | 12.95675 | 21.7 | Pk | 20 | -40 | .5 | 2.2 | 29.54 | -27.34 | 0-360 |
| 9 | 13.28875 | 20.67 | Pk | 20 | -40 | .5 | 1.17 | 40.51 | -39.34 | 0-360 |
| 10 | 13.44575 | 20.82 | Pk | 20 | -40 | .5 | 1.32 | 50.5 | -49.18 | 0-360 |
| **11 | 13.5605 | 34.63 | Pk | 20 | -40 | .5 | 15.13 | 84 | -68.87 | 0-360 |
| 12 | 13.6345 | 22.28 | Pk | 20 | -40 | .6 | 2.88 | 50.5 | -47.62 | 0-360 |
| 13 | 13.77 | 21.9 | Pk | 20 | -40 | .6 | 2.5 | 40.51 | -38.01 | 0-360 |
| 14 | 14.43225 | 23.07 | Pk | 20 | -40 | .6 | 3.67 | 29.54 | -25.87 | 0-360 |

Pk - Peak detector
 **Fundamental

Note 1: Although these tests were performed other than open filed test site, adequate comparison measurements were confirmed against 30 m open are test site. Therefore sufficient tests were made to demonstrate that the alternative site produces results that correlate with the ones of tests made in an open field based on KDB 414788.

Note 2: Radiated test were investigated with three receiving antenna axes: Face-on, Face-off and horizontal (parallel to the ground plane) and the worse orientations of Face-on and Face-off were set for final test.

8.1.5. SPURIOUS EMISSION 0.09 TO 30 MHz [EUT with passive TAG mode]

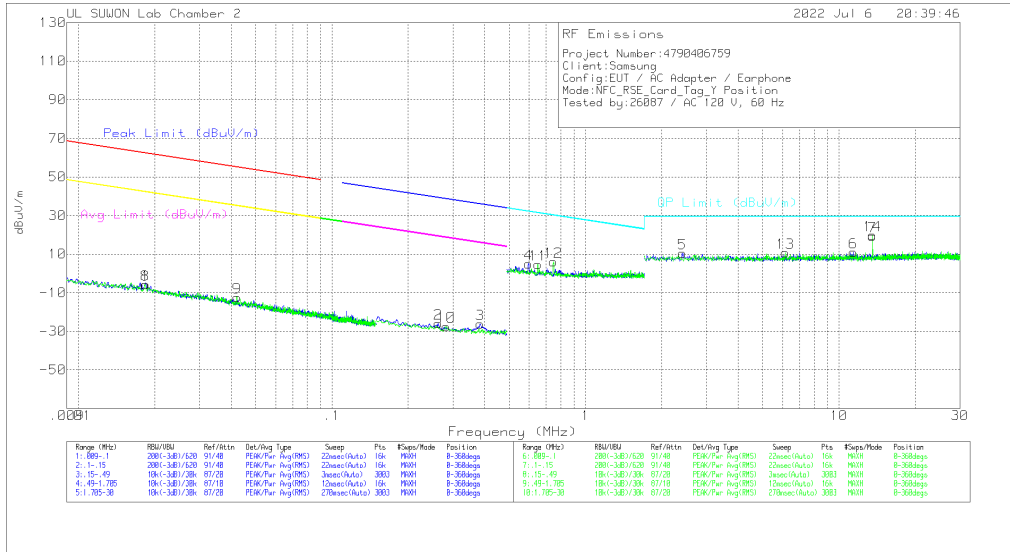

Trace Markers

Face on

| Marker | Frequency (MHz) | Meter Reading (dBuV) | Det | HFH2-Z2_Loop Antenna | Cable Loss | Dist Corr 300m | Corrected Reading dBuV/m | Peak Limit (dBuV/m) | Margin (dB) | Avg Limit (dBuV/m) | Margin (dB) | Azimuth (Degs) |
|--------|-----------------|----------------------|-----|----------------------|------------|----------------|--------------------------|---------------------|-------------|--------------------|-------------|----------------|
| 1 | .01849 | 54.01 | Pk | 20.2 | .1 | -80 | -5.69 | 62.25 | -67.94 | 42.25 | -47.94 | 0-360 |
| 2 | .26272 | 34.23 | Pk | 19.7 | .1 | -80 | -25.97 | 39.22 | -65.19 | 19.22 | -45.19 | 0-360 |
| 3 | .38442 | 33.98 | Pk | 19.7 | .1 | -80 | -26.22 | 35.91 | -62.13 | 15.91 | -42.13 | 0-360 |

| Marker | Frequency (MHz) | Meter Reading (dBuV) | Det | HFH2-Z2_Loop Antenna | Cable Loss | Dist Corr 30m | Corrected Reading dBuV/m | QP Limit (dBuV/m) | Margin (dB) | Azimuth (Degs) |
|--------|-----------------|----------------------|-----|----------------------|------------|---------------|--------------------------|-------------------|-------------|----------------|
| 4 | .59716 | 25.24 | Pk | 19.7 | .1 | -40 | 5.04 | 32.09 | -27.05 | 0-360 |
| 5 | 2.41188 | 30.32 | Pk | 19.9 | .2 | -40 | 10.42 | 29.5 | -19.08 | 0-360 |
| 6 | 11.37505 | 30.51 | Pk | 20 | .5 | -40 | 11.01 | 29.5 | -18.49 | 0-360 |
| **7 | 13.56165 | 38.83 | Pk | 20 | .5 | -40 | 19.33 | 29.5 | -10.17 | 0-360 |

Face off

| Marker | Frequency (MHz) | Meter Reading (dBuV) | Det | HFH2-Z2_Loop Antenna | Cable Loss | Dist Corr 300m | Corrected Reading dBuV/m | Peak Limit (dBuV/m) | Margin (dB) | Avg Limit (dBuV/m) | Margin (dB) | Azimuth (Degs) |
|--------|-----------------|----------------------|-----|----------------------|------------|----------------|--------------------------|---------------------|-------------|--------------------|-------------|----------------|
| 8 | .01833 | 54.02 | Pk | 20.2 | .1 | -80 | -5.68 | 62.32 | -68 | 42.32 | -48 | 0-360 |
| 9 | .04219 | 47.53 | Pk | 19.9 | .1 | -80 | -12.47 | 55.08 | -67.55 | 35.08 | -47.55 | 0-360 |
| 10 | .28227 | 32.78 | Pk | 19.7 | .1 | -80 | -27.42 | 38.6 | -66.02 | 18.6 | -46.02 | 0-360 |

| Marker | Frequency (MHz) | Meter Reading (dBuV) | Det | HFH2-Z2_Loop Antenna | Cable Loss | Dist Corr 30m | Corrected Reading dBuV/m | QP Limit (dBuV/m) | Margin (dB) | Azimuth (Degs) |
|--------|-----------------|----------------------|-----|----------------------|------------|---------------|--------------------------|-------------------|-------------|----------------|
| 11 | .64884 | 24.91 | Pk | 19.7 | .1 | -40 | 4.71 | 31.37 | -26.66 | 0-360 |
| 12 | .74806 | 26.07 | Pk | 19.7 | .2 | -40 | 5.97 | 30.14 | -24.17 | 0-360 |
| 13 | 6.13475 | 30.43 | Pk | 19.8 | .4 | -40 | 10.63 | 29.5 | -18.87 | 0-360 |
| **14 | 13.56165 | 39.32 | Pk | 20 | .5 | -40 | 19.82 | 29.5 | -9.68 | 0-360 |

Pk - Peak detector

**Fundamental

Note 1: The data for marker number 7 and 14 are the fundamental signal.

Please refer to section 8.1.4 about the fundamental level.

Frequency range 0.009MHz ~ 0.490MHz, only noise floor level and more than 20dB margin.

Note 2: Radiated test were investigated with three receiving antenna axes: Face-on, Face-off and horizontal (parallel to the ground plane) and the worse orientations of Face-on and Face-off were set for final test.

8.1.6. TX SPURIOUS EMISSION 30 TO 1000 MHz [EUT with passive TAG mode]

HORIZONTAL

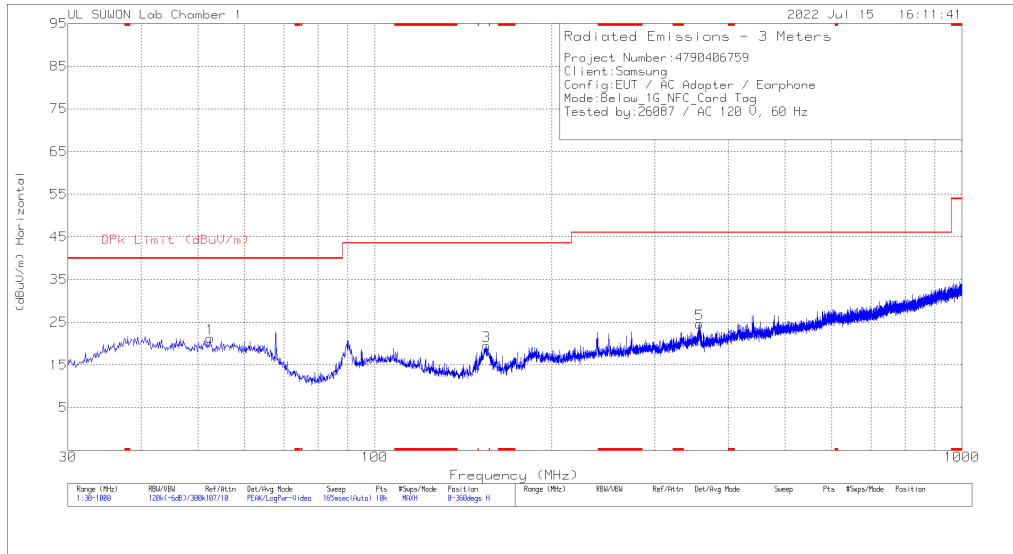

VERTICAL

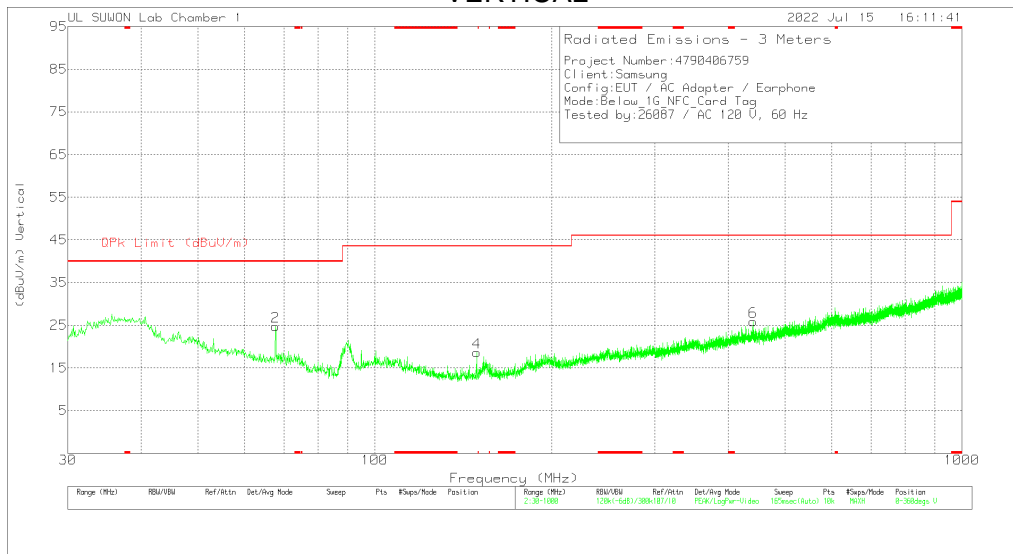

Trace Markers

| Marker | Frequency (MHz) | Meter Reading (dBuV) | Det | VULB9163_750 | Below_1G[dB] | Corrected Reading (dBuV/m) | QPk Limit (dBuV/m) | Margin (dB) | Azimuth (Degs) | Height (cm) | Polarity |
|--------|-----------------|----------------------|-----|--------------|--------------|----------------------------|--------------------|-------------|----------------|-------------|----------|
| 1 | 52.407 | 32.48 | Pk | 19.7 | -30.9 | 21.28 | 40 | -18.72 | 0-360 | 200 | H |
| 3 | 154.839 | 35.13 | Pk | 14.1 | -29.7 | 19.53 | 43.52 | -23.99 | 0-360 | 100 | H |
| 5 | 357.569 | 32.56 | Pk | 20.4 | -28.3 | 24.66 | 46.02 | -21.36 | 0-360 | 100 | H |
| 2 | 67.733 | 39.14 | Pk | 16.3 | -30.7 | 24.74 | 40 | -15.26 | 0-360 | 300 | V |
| 4 | 149.116 | 34.59 | Pk | 13.9 | -29.8 | 18.69 | 43.52 | -24.83 | 0-360 | 200 | V |
| 6 | 440.698 | 31.71 | Pk | 22.1 | -27.9 | 25.91 | 46.02 | -20.11 | 0-360 | 200 | V |

Pk - Peak detector

9. AC MAINS LINE CONDUCTED EMISSIONS

LIMITS

§15.207

(a) Except as shown in paragraphs (b) and (c) of this section, for an intentional radiator that is designed to be connected to the public utility (AC) power line, the radio frequency voltage that is conducted back onto the AC power line on any frequency or frequencies, within the band 150 kHz to 30 MHz, shall not exceed the limits in the following table, as measured using a 50 μ H/50 ohms line impedance stabilization network (LISN). Compliance with the provisions of this paragraph shall be based on the measurement of the radio frequency voltage between each power line and ground at the power terminal. The lower limit applies at the band edges.

| Frequency range (MHz) | Limits (dB μ V) | |
|--------------------------|---------------------|----------|
| | Quasi-peak | Average |
| 0.15 to 0.50 | 66 to 56 | 56 to 46 |
| 0.50 to 5 | 56 | 46 |
| 5 to 30 | 60 | 50 |

Notes:

1. The lower limit shall apply at the transition frequencies
2. The limit decreases linearly with the logarithm of the frequency in the range 0.15 MHz to 0.50 MHz.

TEST PROCEDURE

The EUT is placed on a non-conducting table 40 cm from the vertical ground plane and 80 cm above the horizontal ground plane. The EUT is configured in accordance with ANSI C63.10.

The receiver is set to a resolution bandwidth of 9 kHz. Peak detection is used unless otherwise noted as quasi-peak or average.

Line conducted data is recorded for both NEUTRAL and HOT lines.

RESULTS

No non-compliance noted:

9.1.1. AC Power Line (C to C)

WORST EMISSIONS

LINE 1 PLOT

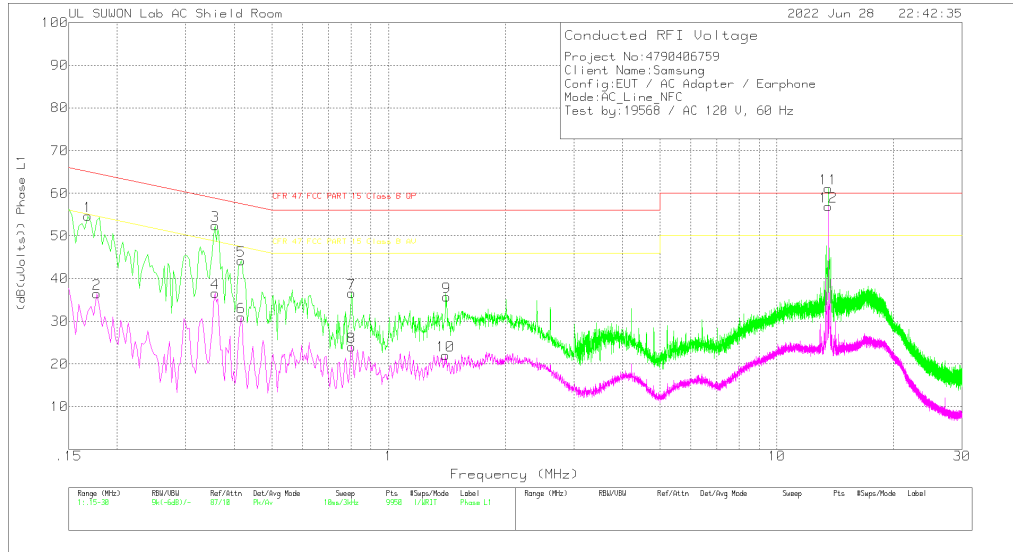

LINE 1 RESULTS

Trace Markers

Range 1: Phase L1 .15 - 30MHz

| Marker | Frequency (MHz) | Meter Reading (dBuV) | Det | 101836_With EX_L1[dB] | CABLELOS S(dB) | Corrected Reading (dB(uVolts)) | CFR 47 FCC PART 15 Class B QP | Margin (dB) | CFR 47 FCC PART 15 Class B AV | Margin (dB) |
|--------|-----------------|----------------------|-----|-----------------------|----------------|--------------------------------|-------------------------------|-------------|-------------------------------|-------------|
| 1 | .168 | 44.61 | Pk | 10 | .1 | 54.71 | 65.06 | -10.35 | - | - |
| 2 | .177 | 26.39 | Av | 9.9 | .2 | 36.49 | - | - | 54.63 | -18.14 |
| 3 | .357 | 42.42 | Pk | 9.8 | .2 | 52.42 | 58.8 | -6.38 | - | - |
| 4 | .357 | 26.56 | Av | 9.8 | .2 | 36.56 | - | - | 48.8 | -12.24 |
| 5 | .417 | 34.19 | Pk | 9.8 | .2 | 44.19 | 57.51 | -13.32 | - | - |
| 6 | .417 | 21.04 | Av | 9.8 | .2 | 31.04 | - | - | 47.51 | -16.47 |
| 7 | .804 | 26.57 | Pk | 9.8 | .2 | 36.57 | 56 | -19.43 | - | - |
| 8 | .804 | 14.04 | Av | 9.8 | .2 | 24.04 | - | - | 46 | -21.96 |
| 9 | 1.41 | 25.78 | Pk | 9.7 | .3 | 35.78 | 56 | -20.22 | - | - |
| 10 | 1.401 | 11.96 | Av | 9.7 | .3 | 21.96 | - | - | 46 | -24.04 |
| 11 | 13.56 | 50.74 | Pk | 10 | .4 | 61.14 | 60 | 1.14 | - | - |
| 12 | 13.56 | 46.56 | Av | 10 | .4 | 56.96 | - | - | 50 | 6.96 |

Pk - Peak detector

Av - Average detection

Quasi-Peak Emissions

Range 1: Phase L1 .15 - 30MHz

| Frequency (MHz) | Meter Reading (dBuV) | Det | 101836_With EX_L1[dB] | CABLELOS S(dB) | Corrected Reading (dB(uVolts)) | CFR 47 FCC PART 15 Class B QP | Margin (dB) | CFR 47 FCC PART 15 Class B AV | Margin (dB) |
|-----------------|----------------------|-----|-----------------------|----------------|--------------------------------|-------------------------------|-------------|-------------------------------|-------------|
| .35775 | 27.35 | Qp | 9.8 | .2 | 37.35 | 58.78 | -21.43 | - | - |
| 13.5602 | 51.59 | Qp | 10 | .4 | 61.99 | 60 | 1.99 | - | - |

Qp - Quasi-Peak detector

LINE 2 PLOT

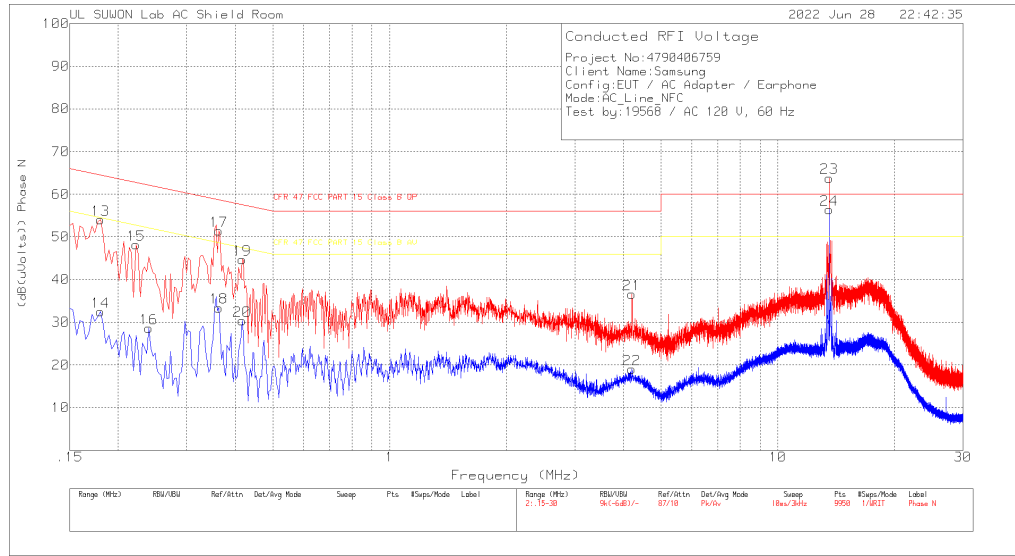

LINE 2 RESULTS

Trace Markers

Range 2: Phase N .15 - 30MHz

| Marker | Frequency (MHz) | Meter Reading (dBuV) | Det | 101836_With EX_N[dB] | CABLELOSS S(dB) | Corrected Reading (dB(uVolts)) | CFR 47 FCC PART 15 Class B QP | Margin (dB) | CFR 47 FCC PART 15 Class B AV | Margin (dB) |
|--------|-----------------|----------------------|-----|----------------------|-----------------|--------------------------------|-------------------------------|-------------|-------------------------------|-------------|
| 13 | .18 | 43.9 | Pk | 9.9 | .2 | 54 | 64.49 | -10.49 | - | - |
| 14 | .18 | 22.34 | Av | 9.9 | .2 | 32.44 | - | - | 54.49 | -22.05 |
| 15 | .222 | 38.27 | Pk | 9.7 | .2 | 48.17 | 62.74 | -14.57 | - | - |
| 16 | .24 | 18.77 | Av | 9.7 | .2 | 28.67 | - | - | 52.1 | -23.43 |
| 17 | .363 | 41.48 | Pk | 9.8 | .2 | 51.48 | 58.66 | -7.18 | - | - |
| 18 | .363 | 23.42 | Av | 9.8 | .2 | 33.42 | - | - | 48.66 | -15.24 |
| 19 | .417 | 34.72 | Pk | 9.8 | .2 | 44.72 | 57.51 | -12.79 | - | - |
| 20 | .417 | 20.38 | Av | 9.8 | .2 | 30.38 | - | - | 47.51 | -17.13 |
| 21 | 4.212 | 26.61 | Pk | 9.7 | .3 | 36.61 | 56 | -19.39 | - | - |
| 22 | 4.212 | 9.04 | Av | 9.7 | .3 | 19.04 | - | - | 46 | -26.96 |
| 23 | 13.56 | 53.43 | Pk | 10 | .4 | 63.83 | 60 | 3.83 | - | - |
| 24 | 13.56 | 46.07 | Av | 10 | .4 | 56.47 | - | - | 50 | 6.47 |

Pk - Peak detector

Av - Average detection

Quasi-Peak Emissions

Range 2: Phase N .15 - 30MHz

| Frequency (MHz) | Meter Reading (dBuV) | Det | 101836_With EX_N[dB] | CABLELOSS (dB) | Corrected Reading (dB(uVolts)) | CFR 47 FCC PART 15 Class B QP | Margin (dB) | CFR 47 FCC PART 15 Class B AV | Margin (dB) |
|-----------------|----------------------|-----|----------------------|----------------|--------------------------------|-------------------------------|-------------|-------------------------------|-------------|
| .36375 | 37.44 | Qp | 9.8 | .2 | 47.44 | 58.64 | -11.2 | - | - |
| 13.5602 | 49.05 | Qp | 10 | .4 | 59.45 | 60 | -.55 | - | - |

Qp - Quasi-Peak detector

TERMINATED EMISSIONS

LINE 1 PLOT

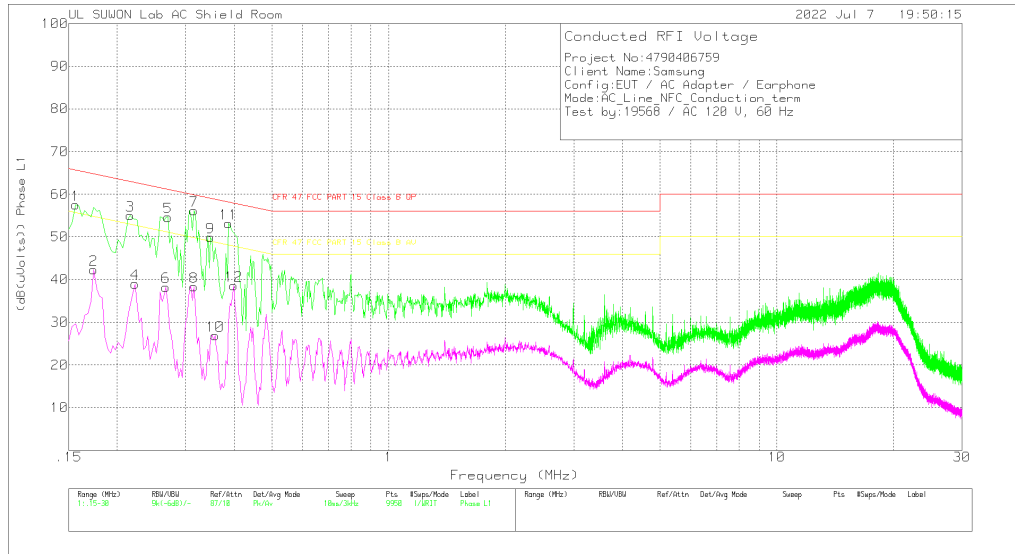

LINE 1 RESULTS

Trace Markers

Range 1: Phase L1 .15 - 30MHz

| Marker | Frequency (MHz) | Meter Reading (dBuV) | Det | 101836_With EX_L1[dB] | CABLELOS S(dB) | Corrected Reading (dB(uVolts)) | CFR 47 FCC PART 15 Class B QP | Margin (dB) | CFR 47 FCC PART 15 Class B AV | Margin (dB) |
|--------|-----------------|----------------------|-----|-----------------------|----------------|--------------------------------|-------------------------------|-------------|-------------------------------|-------------|
| 1 | .156 | 47.67 | Pk | 9.8 | .1 | 57.57 | 65.67 | -8.1 | - | - |
| 2 | .174 | 32.15 | Av | 10 | .2 | 42.35 | - | - | 54.77 | -12.42 |
| 3 | .216 | 45.04 | Pk | 9.8 | .2 | 55.04 | 62.97 | -7.93 | - | - |
| 4 | .222 | 29.13 | Av | 9.7 | .2 | 39.03 | - | - | 52.74 | -13.71 |
| 5 | .27 | 44.81 | Pk | 9.6 | .2 | 54.61 | 61.12 | -6.51 | - | - |
| 6 | .267 | 28.48 | Av | 9.6 | .2 | 38.28 | - | - | 51.21 | -12.93 |
| 7 | .315 | 46.25 | Pk | 9.7 | .2 | 56.15 | 59.84 | -3.69 | - | - |
| 8 | .315 | 28.42 | Av | 9.7 | .2 | 38.32 | - | - | 49.84 | -11.52 |
| 9 | .348 | 39.88 | Pk | 9.8 | .2 | 49.88 | 59.01 | -9.13 | - | - |
| 10 | .357 | 16.83 | Av | 9.8 | .2 | 26.83 | - | - | 48.8 | -21.97 |
| 11 | .387 | 43.16 | Pk | 9.8 | .2 | 53.16 | 58.13 | -4.97 | - | - |
| 12 | .399 | 28.64 | Av | 9.8 | .2 | 38.64 | - | - | 47.87 | -9.23 |

Pk - Peak detector

Av - Average detection

Quasi-Peak Emissions

Range 1: Phase L1 .15 - 30MHz

| Frequency (MHz) | Meter Reading (dBuV) | Det | 101836_With EX_L1[dB] | CABLELOS S(dB) | Corrected Reading (dB(uVolts)) | CFR 47 FCC PART 15 Class B QP | Margin (dB) | CFR 47 FCC PART 15 Class B AV | Margin (dB) |
|-----------------|----------------------|-----|-----------------------|----------------|--------------------------------|-------------------------------|-------------|-------------------------------|-------------|
| .15675 | 40.33 | Qp | 9.8 | .1 | 50.23 | 65.63 | -15.4 | - | - |
| .21675 | 41.58 | Qp | 9.8 | .2 | 51.58 | 62.94 | -11.36 | - | - |
| .26925 | 40.13 | Qp | 9.6 | .2 | 49.93 | 61.14 | -11.21 | - | - |
| .31425 | 42.32 | Qp | 9.7 | .2 | 52.22 | 59.86 | -7.64 | - | - |
| .34725 | 35.22 | Qp | 9.8 | .2 | 45.22 | 59.03 | -13.81 | - | - |
| .38775 | 38.98 | Qp | 9.8 | .2 | 48.98 | 58.11 | -9.13 | - | - |

Qp - Quasi-Peak detector

LINE 2 PLOT

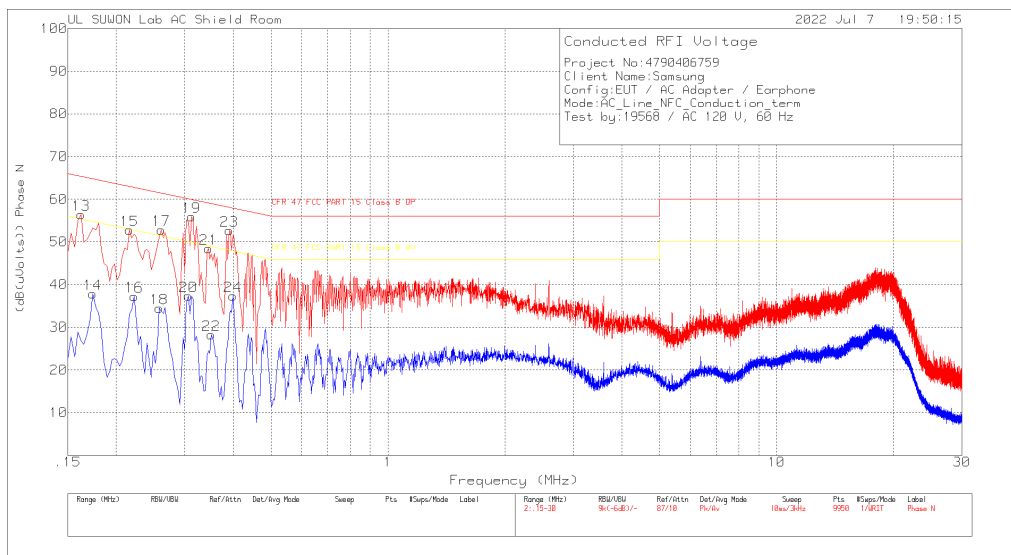

LINE 2 RESULTS

Trace Markers

Range 2: Phase N .15 - 30MHz

| Marker | Frequency (MHz) | Meter Reading (dBuV) | Det | 101836_With EX_N[dB] | CABLELOS S(dB) | Corrected Reading (dB(uVolts)) | CFR 47 FCC PART 15 Class B QP | Margin (dB) | CFR 47 FCC PART 15 Class B AV | Margin (dB) |
|--------|-----------------|----------------------|-----|----------------------|----------------|--------------------------------|-------------------------------|-------------|-------------------------------|-------------|
| 13 | .162 | 46.46 | Pk | 9.9 | .1 | 56.46 | 65.36 | -8.9 | - | - |
| 14 | .174 | 27.65 | Av | 10 | .2 | 37.85 | - | - | 54.77 | -16.92 |
| 15 | .216 | 42.75 | Pk | 9.8 | .2 | 52.75 | 62.97 | -10.22 | - | - |
| 16 | .222 | 27.38 | Av | 9.7 | .2 | 37.28 | - | - | 52.74 | -15.46 |
| 17 | .261 | 43.06 | Pk | 9.6 | .2 | 52.86 | 61.4 | -8.54 | - | - |
| 18 | .258 | 24.66 | Av | 9.6 | .2 | 34.46 | - | - | 51.5 | -17.04 |
| 19 | .312 | 45.98 | Pk | 9.7 | .2 | 55.88 | 59.92 | -4.04 | - | - |
| 20 | .306 | 27.5 | Av | 9.7 | .2 | 37.4 | - | - | 50.08 | -12.68 |
| 21 | .345 | 38.38 | Pk | 9.8 | .2 | 48.38 | 59.08 | -10.7 | - | - |
| 22 | .351 | 18.21 | Av | 9.8 | .2 | 28.21 | - | - | 48.94 | -20.73 |
| 23 | .39 | 42.62 | Pk | 9.8 | .2 | 52.62 | 58.06 | -5.44 | - | - |
| 24 | .399 | 27.31 | Av | 9.8 | .2 | 37.31 | - | - | 47.87 | -10.56 |

Pk - Peak detector

Av - Average detection

Quasi-Peak Emissions

Range 2: Phase N .15 - 30MHz

| Frequency (MHz) | Meter Reading (dBuV) | Det | 101836_With EX_N[dB] | CABLELOS S(dB) | Corrected Reading (dB(uVolts)) | CFR 47 FCC PART 15 Class B QP | Margin (dB) | CFR 47 FCC PART 15 Class B AV | Margin (dB) |
|-----------------|----------------------|-----|----------------------|----------------|--------------------------------|-------------------------------|-------------|-------------------------------|-------------|
| .16125 | 37.99 | Qp | 9.9 | .1 | 47.99 | 65.4 | -17.41 | - | - |
| .26175 | 39.51 | Qp | 9.6 | .2 | 49.31 | 61.38 | -12.07 | - | - |
| .31275 | 42.47 | Qp | 9.7 | .2 | 52.37 | 59.9 | -7.53 | - | - |
| .38925 | 39.3 | Qp | 9.8 | .2 | 49.3 | 58.08 | -8.78 | - | - |

Qp - Quasi-Peak detector

9.1.2. AC Power Line (A to C)

WORST EMISSIONS

LINE 1 PLOT

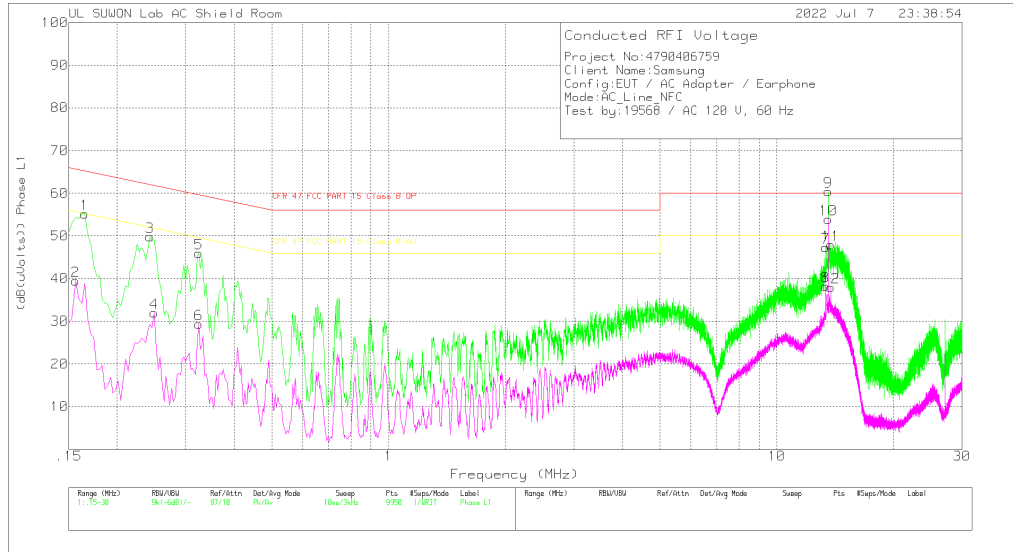

LINE 1 RESULTS

Trace Markers

Range 1: Phase L1 .15 - 30MHz

| Marker | Frequency (MHz) | Meter Reading (dBuV) | Det | 101836_With EX_L1[dB] | CABLELOSS S(dB) | Corrected Reading (dB(uVolts)) | CFR 47 FCC PART 15 Class B QP | Margin (dB) | CFR 47 FCC PART 15 Class B AV | Margin (dB) |
|--------|-----------------|----------------------|-----|-----------------------|-----------------|--------------------------------|-------------------------------|-------------|-------------------------------|-------------|
| 1 | .165 | 45.2 | Pk | 9.9 | .1 | 55.2 | 65.21 | -10.01 | - | - |
| 2 | .156 | 29.53 | Av | 9.8 | .1 | 39.43 | - | - | 55.67 | -16.24 |
| 3 | .243 | 39.96 | Pk | 9.6 | .2 | 49.76 | 61.99 | -12.23 | - | - |
| 4 | .249 | 22.18 | Av | 9.6 | .2 | 31.98 | - | - | 51.79 | -19.81 |
| 5 | .324 | 36.03 | Pk | 9.7 | .2 | 45.93 | 59.6 | -13.67 | - | - |
| 6 | .324 | 19.5 | Av | 9.7 | .2 | 29.4 | - | - | 49.6 | -20.2 |
| 7 | 13.347 | 36.87 | Pk | 10 | .4 | 47.27 | 60 | -12.73 | - | - |
| 8 | 13.347 | 27.84 | Av | 10 | .4 | 38.24 | - | - | 50 | -11.76 |
| 9 | 13.56 | 49.96 | Pk | 10 | .4 | 60.36 | 60 | .36 | - | - |
| 10 | 13.56 | 43.5 | Av | 10 | .4 | 53.9 | - | - | 50 | 3.9 |
| 11 | 13.773 | 37.51 | Pk | 10 | .4 | 47.91 | 60 | -12.09 | - | - |
| 12 | 13.773 | 27.58 | Av | 10 | .4 | 37.98 | - | - | 50 | -12.02 |

Pk - Peak detector

Av - Average detection

Quasi-Peak Emissions

Range 1: Phase L1 .15 - 30MHz

| Frequency (MHz) | Meter Reading (dBuV) | Det | 101836_With EX_L1[dB] | CABLELOSS (dB) | Corrected Reading (dB(uVolts)) | CFR 47 FCC PART 15 Class B QP | Margin (dB) | CFR 47 FCC PART 15 Class B AV | Margin (dB) |
|-----------------|----------------------|-----|-----------------------|----------------|--------------------------------|-------------------------------|-------------|-------------------------------|-------------|
| 13.5602 | 47.43 | Qp | 10 | .4 | 57.83 | 60 | -2.17 | - | - |

Qp - Quasi-Peak detector

LINE 2 PLOT

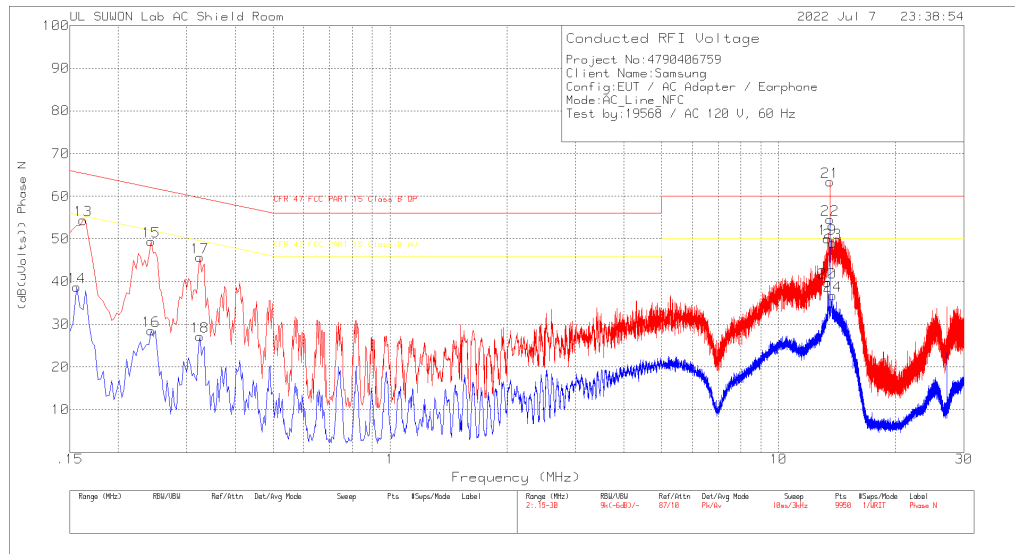

LINE 2 RESULTS

Trace Markers

Range 2: Phase N .15 - 30MHz

| Marker | Frequency (MHz) | Meter Reading (dBuV) | Det | 101836_With EX_N[dB] | CABLELOS S(dB) | Corrected Reading (dB(uVolts)) | CFR 47 FCC PART 15 Class B QP | Margin (dB) | CFR 47 FCC PART 15 Class B AV | Margin (dB) |
|--------|-----------------|----------------------|-----|----------------------|----------------|--------------------------------|-------------------------------|-------------|-------------------------------|-------------|
| 13 | .162 | 44.36 | Pk | 9.9 | .1 | 54.36 | 65.36 | -11 | - | - |
| 14 | .156 | 28.78 | Av | 9.8 | .1 | 38.68 | - | - | 55.67 | -16.99 |
| 15 | .243 | 39.63 | Pk | 9.6 | .2 | 49.43 | 61.99 | -12.56 | - | - |
| 16 | .243 | 18.71 | Av | 9.6 | .2 | 28.51 | - | - | 51.99 | -23.48 |
| 17 | .324 | 35.83 | Pk | 9.7 | .2 | 45.73 | 59.6 | -13.87 | - | - |
| 18 | .324 | 17.24 | Av | 9.7 | .2 | 27.14 | - | - | 49.6 | -22.46 |
| 19 | 13.35 | 39.62 | Pk | 10 | .4 | 50.02 | 60 | -9.98 | - | - |
| 20 | 13.35 | 29.43 | Av | 10 | .4 | 39.83 | - | - | 50 | -10.17 |
| 21 | 13.56 | 53 | Pk | 10 | .4 | 63.4 | 60 | 3.4 | - | - |
| 22 | 13.56 | 44.18 | Av | 10 | .4 | 54.58 | - | - | 50 | 4.58 |
| 23 | 13.791 | 38.71 | Pk | 10 | .4 | 49.11 | 60 | -10.89 | - | - |
| 24 | 13.77 | 26.29 | Av | 10 | .4 | 36.69 | - | - | 50 | -13.31 |

Pk - Peak detector

Av - Average detection

Quasi-Peak Emissions

Range 2: Phase N .15 - 30MHz

| Frequency (MHz) | Meter Reading (dBuV) | Det | 101836_With EX_N[dB] | CABLELOS S(dB) | Corrected Reading (dB(uVolts)) | CFR 47 FCC PART 15 Class B QP | Margin (dB) | CFR 47 FCC PART 15 Class B AV | Margin (dB) |
|-----------------|----------------------|-----|----------------------|----------------|--------------------------------|-------------------------------|-------------|-------------------------------|-------------|
| 13.3493 | 35.41 | Qp | 10 | .4 | 45.81 | 60 | -14.19 | - | - |
| 13.5602 | 49.61 | Qp | 10 | .4 | 60.01 | 60 | .01 | - | - |

Qp - Quasi-Peak detector

TERMINATED EMISSIONS

LINE 1 PLOT

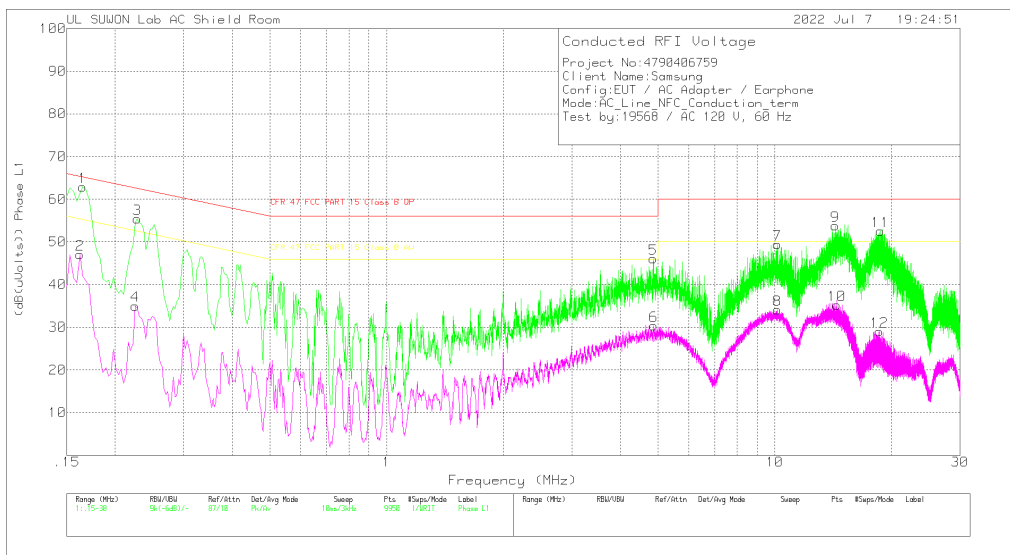

LINE 1 RESULTS

Trace Markers

Range 1: Phase L1 .15 - 30MHz

| Marker | Frequency (MHz) | Meter Reading (dBuV) | Det | 101836_With EX_L1[dB] | CABLELOS S(dB) | Corrected Reading (dB(uVolts)) | CFR 47 FCC PART 15 Class B QP | Margin (dB) | CFR 47 FCC PART 15 Class B AV | Margin (dB) |
|--------|-----------------|----------------------|-----|-----------------------|----------------|--------------------------------|-------------------------------|-------------|-------------------------------|-------------|
| 1 | .165 | 52.92 | Pk | 9.9 | .1 | 62.92 | 65.21 | -2.29 | - | - |
| 2 | .162 | 37.1 | Av | 9.9 | .1 | 47.1 | - | - | 55.36 | -8.26 |
| 3 | .228 | 45.54 | Pk | 9.7 | .2 | 55.44 | 62.52 | -7.08 | - | - |
| 4 | .225 | 25.14 | Av | 9.7 | .2 | 35.04 | - | - | 52.63 | -17.59 |
| 5 | 4.869 | 36.05 | Pk | 9.7 | .3 | 46.05 | 56 | -9.95 | - | - |
| 6 | 4.881 | 20.42 | Av | 9.7 | .3 | 30.42 | - | - | 46 | -15.58 |
| 7 | 10.143 | 39.16 | Pk | 9.9 | .4 | 49.46 | 60 | -10.54 | - | - |
| 8 | 10.143 | 23.84 | Av | 9.9 | .4 | 34.14 | - | - | 50 | -15.86 |
| 9 | 14.298 | 43.42 | Pk | 10 | .4 | 53.82 | 60 | -6.18 | - | - |
| 10 | 14.466 | 24.81 | Av | 10 | .4 | 35.21 | - | - | 50 | -14.79 |
| 11 | 18.732 | 42.1 | Pk | 10.1 | .4 | 52.6 | 60 | -7.4 | - | - |
| 12 | 18.564 | 18.51 | Av | 10.1 | .4 | 29.01 | - | - | 50 | -20.99 |

Pk - Peak detector

Av - Average detection

Quasi-Peak Emissions

Range 1: Phase L1 .15 - 30MHz

| Frequency (MHz) | Meter Reading (dBuV) | Det | 101836_With EX_L1[dB] | CABLELOS S(dB) | Corrected Reading (dB(uVolts)) | CFR 47 FCC PART 15 Class B QP | Margin (dB) | CFR 47 FCC PART 15 Class B AV | Margin (dB) |
|-----------------|----------------------|-----|-----------------------|----------------|--------------------------------|-------------------------------|-------------|-------------------------------|-------------|
| .16575 | 50.76 | Qp | 9.9 | .1 | 60.76 | 65.17 | -4.41 | - | - |
| .22875 | 42.3 | Qp | 9.7 | .2 | 52.2 | 62.49 | -10.29 | - | - |
| 4.86915 | 26.81 | Qp | 9.7 | .3 | 36.81 | 56 | -19.19 | - | - |
| 14.2973 | 35.25 | Qp | 10 | .4 | 45.65 | 60 | -14.35 | - | - |
| 18.7313 | 33.75 | Qp | 10.1 | .4 | 44.25 | 60 | -15.75 | - | - |

Qp - Quasi-Peak detector

LINE 2 PLOT

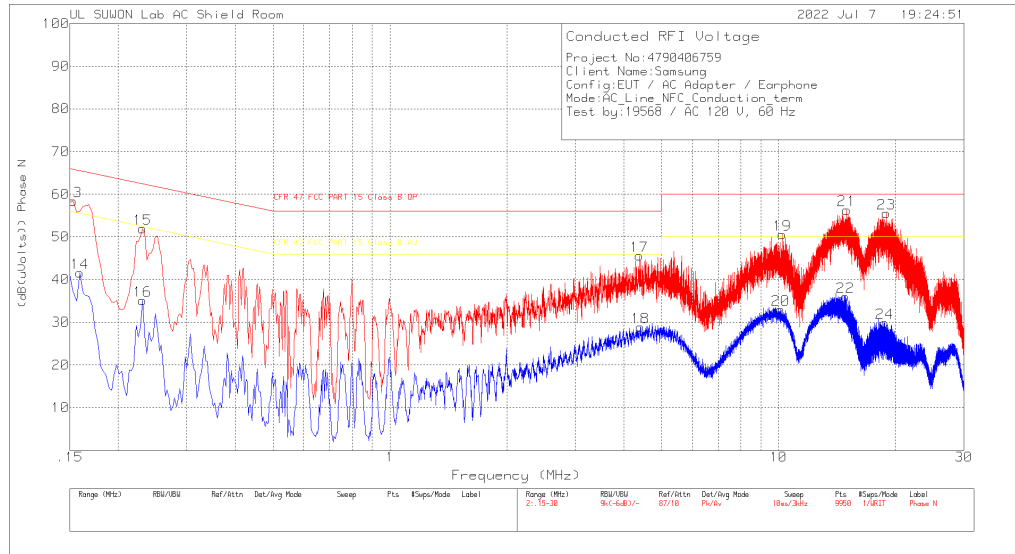

LINE 2 RESULTS

Trace Markers

Range 2: Phase N .15 - 30MHz

| Marker | Frequency (MHz) | Meter Reading (dBuV) | Det | 101836_With EX_N[dB] | CABLELOS S(dB) | Corrected Reading (dB(uVolts)) | CFR 47 FCC PART 15 Class B QP | Margin (dB) | CFR 47 FCC PART 15 Class B AV | Margin (dB) |
|--------|-----------------|----------------------|-----|----------------------|----------------|--------------------------------|-------------------------------|-------------|-------------------------------|-------------|
| 13 | .153 | 48.52 | Pk | 9.8 | .1 | 58.42 | 65.84 | -7.42 | - | - |
| 14 | .159 | 31.65 | Av | 9.8 | .1 | 41.55 | - | - | 55.52 | -13.97 |
| 15 | .231 | 42.03 | Pk | 9.7 | .2 | 51.93 | 62.41 | -10.48 | - | - |
| 16 | .231 | 25.17 | Av | 9.7 | .2 | 35.07 | - | - | 52.41 | -17.34 |
| 17 | 4.386 | 35.54 | Pk | 9.7 | .3 | 45.54 | 56 | -10.46 | - | - |
| 18 | 4.413 | 18.88 | Av | 9.7 | .3 | 28.88 | - | - | 46 | -17.12 |
| 19 | 10.23 | 40.23 | Pk | 9.9 | .4 | 50.53 | 60 | -9.47 | - | - |
| 20 | 10.134 | 22.7 | Av | 9.9 | .4 | 33 | - | - | 50 | -17 |
| 21 | 14.982 | 45.85 | Pk | 10.1 | .4 | 56.35 | 60 | -3.65 | - | - |
| 22 | 14.859 | 25.45 | Av | 10.1 | .4 | 35.95 | - | - | 50 | -14.05 |
| 23 | 18.927 | 44.92 | Pk | 10.2 | .4 | 55.52 | 60 | -4.48 | - | - |
| 24 | 18.783 | 19.29 | Av | 10.2 | .4 | 29.89 | - | - | 50 | -20.11 |

Pk - Peak detector

Av - Average detection

Quasi-Peak Emissions

Range 2: Phase N .15 - 30MHz

| Frequency (MHz) | Meter Reading (dBuV) | Det | 101836_With EX_N[dB] | CABLELOS S(dB) | Corrected Reading (dB(uVolts)) | CFR 47 FCC PART 15 Class B QP | Margin (dB) | CFR 47 FCC PART 15 Class B AV | Margin (dB) |
|-----------------|----------------------|-----|----------------------|----------------|--------------------------------|-------------------------------|-------------|-------------------------------|-------------|
| .15225 | 45.66 | Qp | 9.7 | .1 | 55.46 | 65.88 | -10.42 | - | - |
| 10.2302 | 29.8 | Qp | 9.9 | .4 | 40.1 | 60 | -19.9 | - | - |
| 14.9813 | 37.73 | Qp | 10.1 | .4 | 48.23 | 60 | -11.77 | - | - |
| 18.9278 | 35.91 | Qp | 10.2 | .4 | 46.51 | 60 | -13.49 | - | - |

Qp - Quasi-Peak detector

10. FREQUENCY STABILITY

LIMIT

§15.225 (e) The frequency tolerance of the carrier signal shall be maintained within $\pm 0.01\%$ of the operating frequency, over a temperature variation of -20 degrees to +50 degrees C at normal supply voltage, and for a variation in the primary supply voltage from 85% to 115% of the rated supply voltage at a temperature of 20 degrees C. For battery operated equipment, the equipment tests shall be performed using a new battery.

TEST PROCEDURE

ANSI C63.10 §6.8

RESULTS

| Reference Frequency: EUT Channel 13.56 MHz @ 20°C Limit: ± 100 ppm = 1.356 kHz | | | | | | | | | | |
|---|---------------------|---|----------------|---------------------|----------------|---------------------|----------------|---------------------|----------------|----------------|
| Power Supply (Vdc) | Envir. Temp (°C) | Frequency Deviation Measured with Time Elapse | | | | | | | | |
| | | Start up (MHz) | Delta (ppm) | @ 2mins (MHz) | Delta (ppm) | @ 5mins (MHz) | Delta (ppm) | @ 10 mins (MHz) | Delta (ppm) | Limit (ppm) |
| 3.80 | 50 | 13.559970308 | -7.401 | 13.559961661 | -8.039 | 13.559959544 | -8.195 | 13.559959378 | -8.207 | 100 |
| 3.80 | 40 | 13.559999083 | -5.279 | 13.559993015 | -5.727 | 13.559985477 | -6.282 | 13.559979262 | -6.741 | 100 |
| 3.80 | 30 | 13.560028907 | -3.080 | 13.560021260 | -3.644 | 13.560016195 | -4.017 | 13.56007499 | -4.658 | 100 |
| 3.80 | 20 | 13.560070667 | 0 | 13.560040360 | -2.235 | 13.560040335 | -2.237 | 13.560040308 | -2.239 | 100 |
| 3.80 | 10 | 13.560094218 | 1.737 | 13.560089650 | 1.400 | 13.560084414 | 1.014 | 13.560078643 | 0.588 | 100 |
| 3.80 | 0 | 13.560095704 | 1.846 | 13.560097471 | 1.977 | 13.560097067 | 1.947 | 13.560095525 | 1.833 | 100 |
| 3.80 | -10 | 13.560081097 | 0.769 | 13.560087508 | 1.242 | 13.560091323 | 1.523 | 13.560093997 | 1.720 | 100 |
| 3.80 | -20 | 13.560063147 | -0.555 | 13.560067320 | -0.247 | 13.560070328 | -0.025 | 13.560072683 | 0.149 | 100 |
| 3.80 | -30 | 13.560073013 | 0.173 | 13.560066942 | -0.275 | 13.560066006 | -0.344 | 13.560064603 | -0.447 | 100 |

| Reference Frequency: EUT Channel 13.56 MHz @ 20°C Limit: ± 100 ppm = 1.356 kHz | | | | | | | | | | |
|---|---------------------|---|----------------|---------------------|----------------|---------------------|----------------|---------------------|----------------|----------------|
| Power Supply (Vdc) | Envir. Temp (°C) | Frequency Deviation Measured with Time Elapse | | | | | | | | |
| | | Start up (MHz) | Delta (ppm) | @ 2mins (MHz) | Delta (ppm) | @ 5mins (MHz) | Delta (ppm) | @ 10 mins (MHz) | Delta (ppm) | Limit (ppm) |
| 3.80 | 20 | 13.559976862 | 0 | 13.559978900 | 0.150 | 13.559982003 | 0.379 | 13.559982032 | 0.381 | 100 |
| 3.40 | 20 | 13.559981526 | 0.344 | 13.559983054 | 0.457 | 13.559983247 | 0.471 | 13.559983244 | 0.471 | 100 |
| 4.30 | 20 | 13.559971567 | -0.390 | 13.559977742 | 0.065 | 13.559980835 | 0.293 | 13.559981332 | 0.330 | 100 |

No non-compliance noted.

END OF TEST REPORT