



FCC 47 CFR PART 15 SUBPART B

CERTIFICATION TEST REPORT

FOR

GSM Tablet + Bluetooth, DTS b/g/n

MODEL NUMBER : SM-T561

FCC ID: A3LSMT561

REPORT NUMBER: 15K20424-E5

ISSUE DATE: APRIL 24, 2015

Prepared for

**SAMSUNG ELECTRONICS CO., LTD.
129 SAMSUNG-RO, YEONGTONG-GU, SUWON-SI,
GYEONGGI-DO, 443-742, KOREA**

Prepared by

**UL Korea, Ltd. Suwon Laboratory
218 Maeyeong-ro, Yeongtong-gu,
Suwon-si, Gyeonggi-do, 443-823, Korea
TEL: (031) 337-9902
FAX: (031) 213-5433**



**ACCREDITED
TL-637**

Revision History

<u>Rev.</u>	<u>Issue Date</u>	<u>Revisions</u>	<u>Revised By</u>
--	04/24/15	Initial issue	CY Choi

TABLE OF CONTENTS

1. ATTESTATION OF TEST RESULTS	4
2. TEST METHODOLOGY	5
3. FACILITIES AND ACCREDITATION	5
4. CALIBRATION AND UNCERTAINTY	5
4.1. <i>MEASURING INSTRUMENT CALIBRATION</i>	<i>5</i>
4.2. <i>SAMPLE CALCULATION</i>	<i>5</i>
4.3. <i>MEASUREMENT UNCERTAINTY.....</i>	<i>6</i>
5. EQUIPMENT UNDER TEST	7
5.1. <i>DESCRIPTION OF EUT</i>	<i>7</i>
5.2. <i>PRELIMINARY TEST CONFIGURATIONS.....</i>	<i>7</i>
5.3. <i>MODE(S) OF OPERATION INVESTIGATED.....</i>	<i>7</i>
5.4. <i>MODIFICATIONS</i>	<i>7</i>
5.5. <i>DETAILS OF TESTED SYSTEM</i>	<i>8</i>
6. TEST AND MEASUREMENT EQUIPMENT	10
7. APPLICABLE LIMITS AND TEST RESULTS	11
7.1. <i>RADIATED EMISSIONS.....</i>	<i>11</i>
7.2. <i>AC MAINS LINE CONDUCTED EMISSIONS</i>	<i>16</i>
8. SETUP PHOTOS.....	19

1. ATTESTATION OF TEST RESULTS

COMPANY NAME: SAMSUNG ELECTRONICS CO., LTD.
EUT DESCRIPTION: GSM Tablet + Bluetooth and DTS b/g/n
MODEL NUMBER: SM-T561
SERIAL NUMBER: R32G30232QB
DATE TESTED: MARCH 30 - APRIL 24, 2015

APPLICABLE STANDARDS	
STANDARD	TEST RESULTS
FCC PART 15 SUBPART B	Pass

UL Verification Services Inc. tested the above equipment in accordance with the requirements set forth in the above standards. All indications of Pass/Fail in this report are opinions expressed by UL Verification Services Inc. based on interpretations and/or observations of test results. Measurement Uncertainties were not taken into account and are published for informational purposes only. The test results show that the equipment tested is capable of demonstrating compliance with the requirements as documented in this report.

Note: The results documented in this report apply only to the tested sample, under the conditions and modes of operation as described herein. This document may not be altered or revised in any way unless done so by UL Verification Services Inc. and all revisions are duly noted in the revisions section. Any alteration of this document not carried out by UL Verification Services Inc. will constitute fraud and shall nullify the document. This report must not be used by the client to claim product certification, approval, or endorsement by NVLAP, NIST, any agency of the Federal Government, or any agency of any government.

Approved & Released For
UL Korea, Ltd. By:



Ji Ho Choi
Suwon Lab Manager
UL Korea, Ltd.

Tested By:



CY Choi
Suwon Lab Engineer
UL Korea, Ltd.

2. TEST METHODOLOGY

The tests documented in this report were performed in accordance with ANSI C63.4-2009, FCC CFR 47 Part 2, FCC CFR 47 Part 15.

3. FACILITIES AND ACCREDITATION

The test sites and measurement facilities used to collect data are located at 218 Maeyeong-ro, Yeongtong-gu, Suwon-si, Gyeonggi-do, 443-823, Korea. Line conducted emissions are measured only at the 218 address. The following table identifies which facilities were utilized for radiated emission measurements documented in this report. Specific facilities are also identified in the test results sections.

218 Maeyeong-ro	
<input checked="" type="checkbox"/>	Chamber 1
<input type="checkbox"/>	Chamber 2

UL Korea, Ltd. is accredited by IAS, Laboratory Code TL-637. The full scope of accreditation can be viewed at <http://www.iasonline.org/PDF/TL/TL-637.pdf>.

4. CALIBRATION AND UNCERTAINTY

4.1. MEASURING INSTRUMENT CALIBRATION

The measuring equipment utilized to perform the tests documented in this report has been calibrated in accordance with the manufacturer's recommendations, and is traceable to recognized national standards.

4.2. SAMPLE CALCULATION

Where relevant, the following sample calculation is provided:

$$\begin{aligned} \text{Field Strength (dBuV/m)} &= \text{Measured Voltage (dBuV)} + \text{Antenna Factor (dB/m)} + \\ &\text{Cable Loss (dB)} - \text{Preamp Gain (dB)} \\ 36.5 \text{ dBuV} + 18.7 \text{ dB/m} + 0.6 \text{ dB} - 26.9 \text{ dB} &= 28.9 \text{ dBuV/m} \end{aligned}$$

4.3. MEASUREMENT UNCERTAINTY

Where relevant, the following measurement uncertainty levels have been estimated for tests performed on the apparatus:

PARAMETER	UNCERTAINTY
Conducted Disturbance, 0.15 to 30 MHz	2.32 dB
Radiated Disturbance, Below 1GHz	4.14 dB
Radiated Disturbance, Above 1 GHz	5.97 dB

Uncertainty figures are valid to a confidence level of 95%.

5. EQUIPMENT UNDER TEST

5.1. DESCRIPTION OF EUT

The EUT is a GSM Tablet + Bluetooth and DTS b/g/n.

GENERAL INFORMATION

AC Adapter Power Requirements	100-240 VAC / 50-60 Hz, 2 A
List of frequencies generated or used by the EUT	1.3 GHz (CPU Clock Frequency)

5.2. PRELIMINARY TEST CONFIGURATIONS

The EUT was investigated in three orthogonal orientations X, Y, Z it was determined that X orientation with data transfer was worst-case; therefore, all final radiated testing was performed with the EUT in X orientation with data transfer.

5.3. MODE(S) OF OPERATION INVESTIGATED

Mode	Description
Idle	Receive mode
Data transfer	Copy files from EUT to PC

5.4. MODIFICATIONS

No modifications were made during testing.

5.5. DETAILS OF TESTED SYSTEM

SUPPORT EQUIPMENT & PERIPHERALS

Support Equipment List				
Description	Manufacturer	Model	Serial Number	FCC ID
Desktop	HP	TPC-F047-MT	CZC4430BM3	DoC
Earphone	Samsung	GH59	N/A	DoC
AC Adapter	Samsung	EP-TA12EWE	N/A	N/A
Mouse	HP	SM-2022	FCMHH0C9Z6ZFJ5	N/A
Keyboard	HP	KB-1156	BDMGF0CGA5M2P6	N/A
Monitor	HP	E231	3CQ4250CNN	DoC
SD card	Sandisk	N/A	N/A	DoC

I/O CABLES

I/O Cable List						
Cable No	Port	# of identical ports	Connector Type	Cable Type	Cable Length (m)	Remarks
1	AC Power	1	Power	Unshielded	1.5m	N/A
2	AC Power	1	Power	Unshielded	1.5m	N/A
3	USB	1	Mini-USB	Shielded	1m	N/A
4	Audio	1	Mini-Jack	Unshielded	1m	N/A
5	Keyboard	1	PS/2	Unshielded	1.2m	N/A
6	Mouse	1	USB	Shielded	1.2m	N/A
7	Monitor	1	RGB	Shielded	1.2m	N/A

TEST SETUP

The EUT is installed in a typical configuration. Test software exercised the EUT.

TEST SETUP DIAGRAM

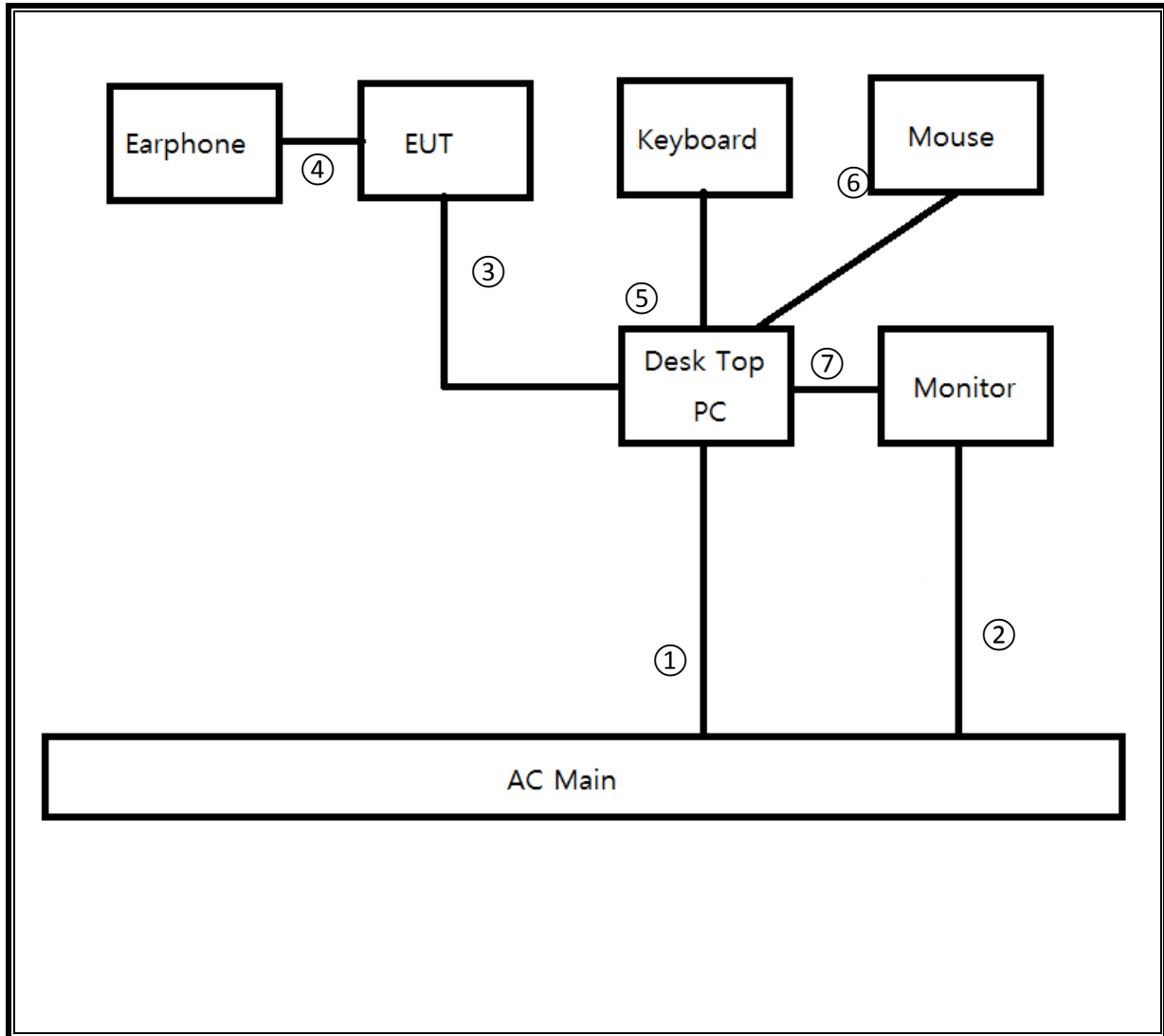

6. TEST AND MEASUREMENT EQUIPMENT

The following test and measurement equipment was utilized for the tests documented in this report:

Test Equipment List				
Description	Manufacturer	Model	S/N	Cal Due
Antenna, Bilog, 30MHz-1GHz	SCHWARZBECK	VULB9163	950	11-17-15
Antenna, Horn, 18 GHz	ETS	3115	00167211	09-20-15
Preamplifier, 1000 MHz	Sonoma	310N	341282	11-17-15
Preamplifier, 18 GHz	Miteq	AFS42-00101800-25-S-42	1876511	11-18-15
EMI Test Receive, 40 GHz	R&S	ESU40	100439	11-17-15
EMI Test Receive, 3 GHz	R&S	ESR3	101832	11-17-15
Attenuator / Switch driver	HP	11713A	3748A04272	N/A
LISN	R&S	ENV-216	101836	04-09-16
LISN	R&S	ENV-216	101837	04-09-16

7. APPLICABLE LIMITS AND TEST RESULTS

7.1. RADIATED EMISSIONS

TEST PROCEDURE

ANSI C63.4: 2009

The highest clock frequency generated or used in the EUT is 1.0GHz therefore the frequency range was investigated from 30 MHz to 18 GHz.

LIMIT

§15.109 (a) Except for Class A digital devices, the field strength of radiated emissions from unintentional radiators at a distance of 3 meters shall not exceed the following values:

Limits for radiated disturbance of Class B ITE at measuring distance of 3 m	
Frequency range (MHz)	Quasi-peak limits (dB μ V/m)
30 to 88	40
88 to 216	43.5
216 to 960	46
Above 960 MHz	54

Note: The lower limit shall apply at the transition frequency.

RESULTS

RADIATED EMISSIONS 30 TO 1000 MHz (WORST-CASE CONFIGURATION)

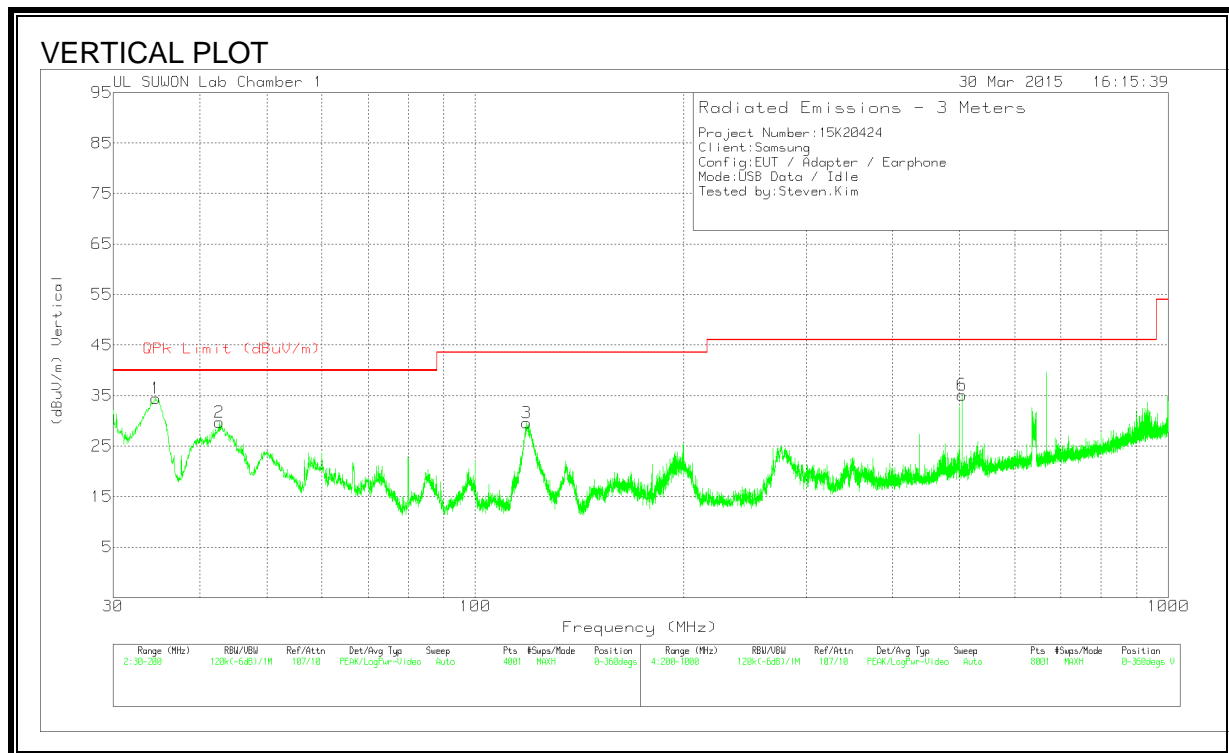
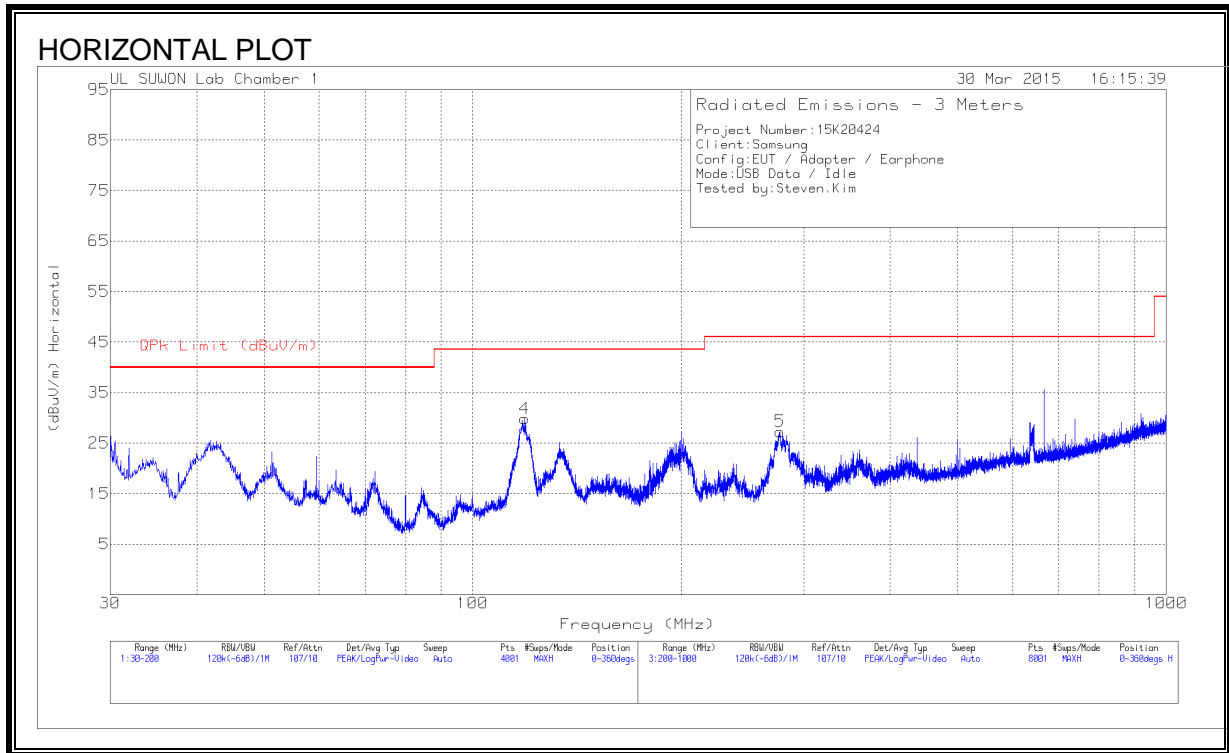

HORIZONTAL AND VERTICAL DATA

Marker	Frequency (MHz)	Meter Reading (dBuV)	Det	VULB9163-750	Bi-Log	Corrected Reading (dBuV/m)	QPk Limit (dBuV/m)	Margin (dB)	Azimuth (Degs)	Height (cm)	Polarity
4	118.91	48.76	Pk	10.1	-29	29.86	43.52	-13.66	0-360	200	H
1	34.59	54.33	Pk	10.5	-30.4	34.43	40	-5.57	0-360	100	V
2	42.7075	46.83	Pk	13.1	-30.2	29.73	40	-10.27	0-360	100	V
3	118.5275	48.47	Pk	10.1	-29	29.57	43.52	-13.95	0-360	100	V
5	277.2	41.98	Pk	12.9	-27.6	27.28	46.02	-18.74	0-360	100	H
6	504	44.21	Pk	17.1	-26.2	35.11	46.02	-10.91	0-360	100	V

Pk - Peak detector

RADIATED EMISSIONS 1GHz to 18GHz (WORST-CASE CONFIGURATION)

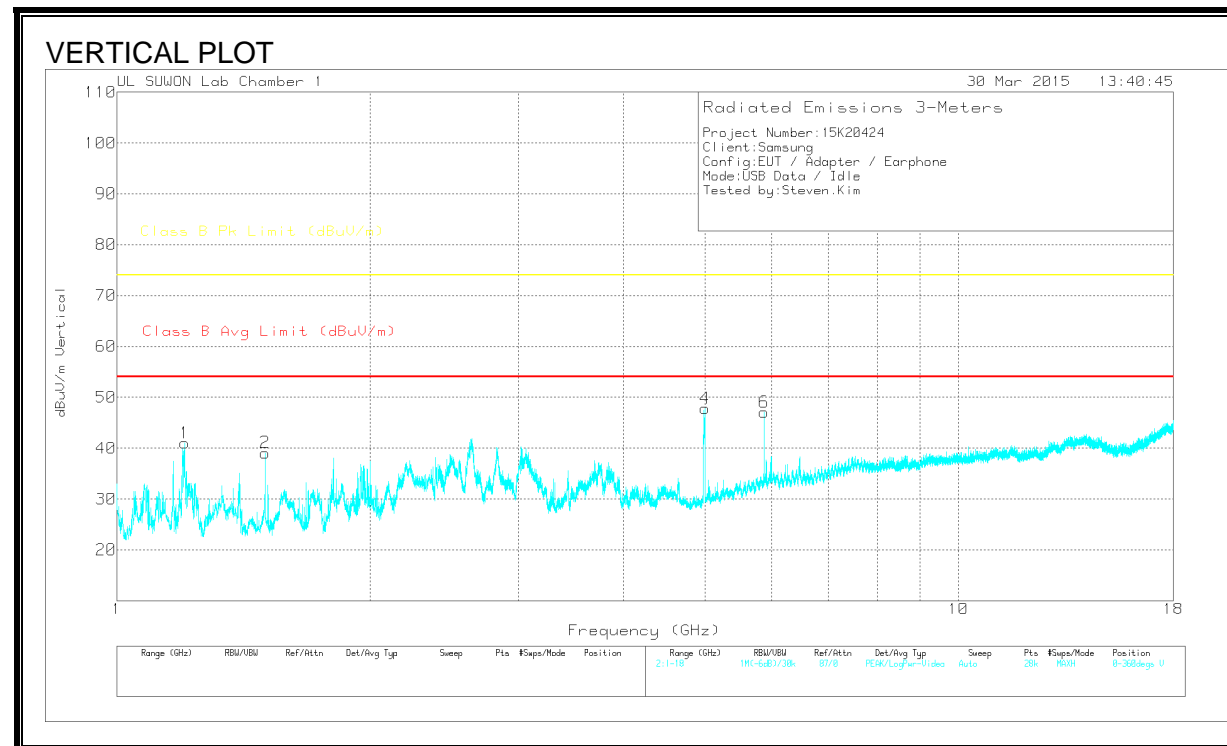
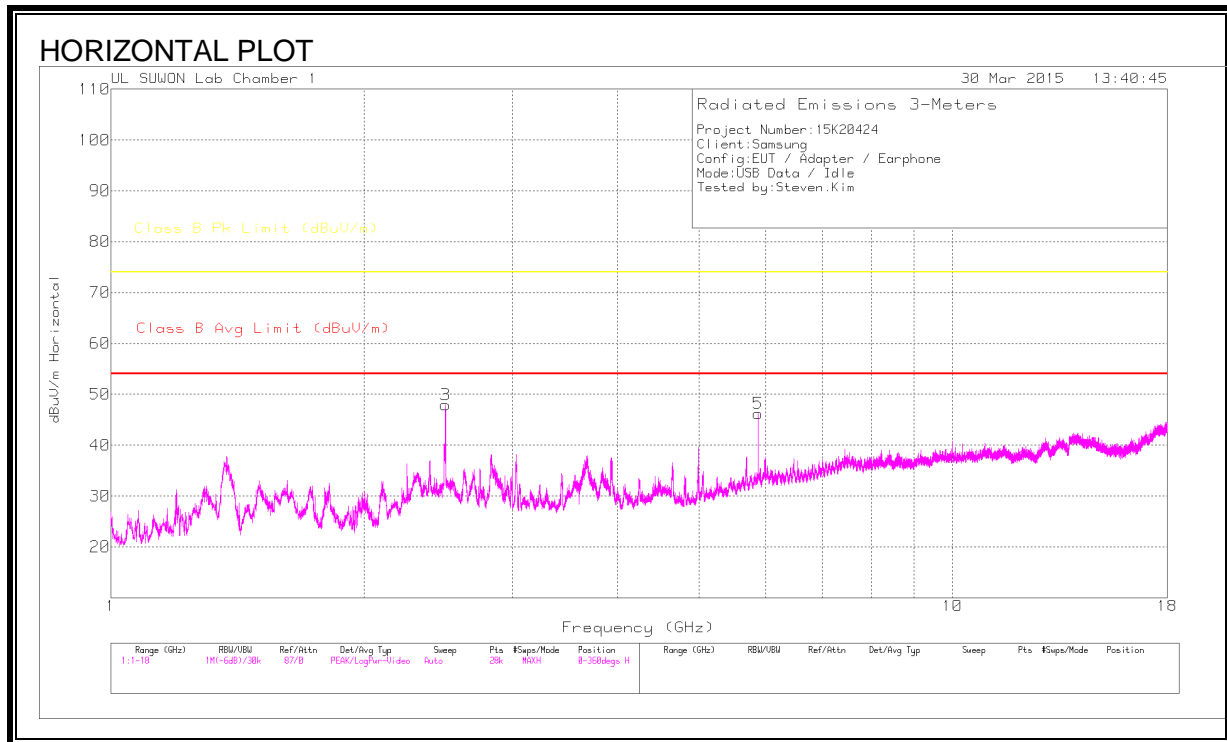

HORIZONTAL AND VERTICAL DATA

Trace Markers

Marker	Frequency (GHz)	Meter Reading (dBuV)	Det	3115D Factor	Path_1_1-18G	Corrected Reading dBuV/m	Class B Avg Limit (dBuV/m)	Av(CISPR) Margin (dB)	Class B Pk Limit (dBuV/m)	Margin (dB)	Azimuth (Degs)	Height (cm)	Polarity
3	2.498	53.19	PK	27.9	-33.2	47.89	-	-	74	-26.11	0-360	200	H
5	5.878	40.56	PK	34.8	-29.1	46.26	-	-	74	-27.74	0-360	200	H
1	1.204	52.88	PK	23.8	-35.7	40.98	-	-	74	-33.02	0-360	100	V
2	1.5	49.6	PK	24.6	-35.1	39.1	-	-	74	-34.9	0-360	200	V
4	4.998	45.47	PK	32.2	-29.8	47.87	-	-	74	-26.13	0-360	200	V
6	5.878	41.38	PK	34.8	-29.1	47.08	-	-	74	-26.92	0-360	200	V

PK – Peak Detector

Radiated Emissions

Frequency (GHz)	Meter Reading (dBuV)	Det	3115D Factor	Path_1_1-18G	Corrected Reading dBuV/m	Class B Avg Limit (dBuV/m)	Av(CISPR) Margin (dB)	Class B Pk Limit (dBuV/m)	Margin (dB)	Azimuth (Degs)	Height (cm)	Polarity
5.879	44.62	Pk	34.8	-29.1	50.32	-	-	74	-23.68	5	149	H
5.879	40.92	Ca	34.8	-29.1	46.62	54	-7.38	74	-27.38	5	149	H
5.879	46.33	Pk	34.8	-29.1	52.03	-	-	74	-21.97	22	167	V
5.88	41.68	Ca	34.8	-29.1	47.38	54	-6.62	74	-26.62	22	200	V

Pk - Peak detector

Ca - CISPR average detection

7.2. AC MAINS LINE CONDUCTED EMISSIONS

TEST PROCEDURE

ANSI C63.4: 2009

LIMIT

§15.107 (a) Except for Class A digital devices, for equipment that is designed to be connected to the public utility (AC) power line, the radio frequency voltage that is conducted back onto the AC power line on any frequency or frequencies within the band 150 kHz to 30 MHz shall not exceed the limits in the following table, as measured using a 50 μ H/50 ohms line impedance stabilization network (LISN). Compliance with the provisions of this paragraph shall be based on the measurement of the radio frequency voltage between each power line and ground at the power terminal. The lower limit applies at the band edges.

Frequency range (MHz)	Limits (dB μ V)	
	Quasi-peak	Average
0.15 to 0.50	66 to 56	56 to 46
0.50 to 5	56	46
5 to 30	60	50

Notes:
1. The lower limit shall apply at the transition frequencies
2. The limit decreases linearly with the logarithm of the frequency in the range 0.15 MHz to 0.50 MHz.

RESULTS

6 WORST EMISSIONS

Line-L1 .15 - 30MHz

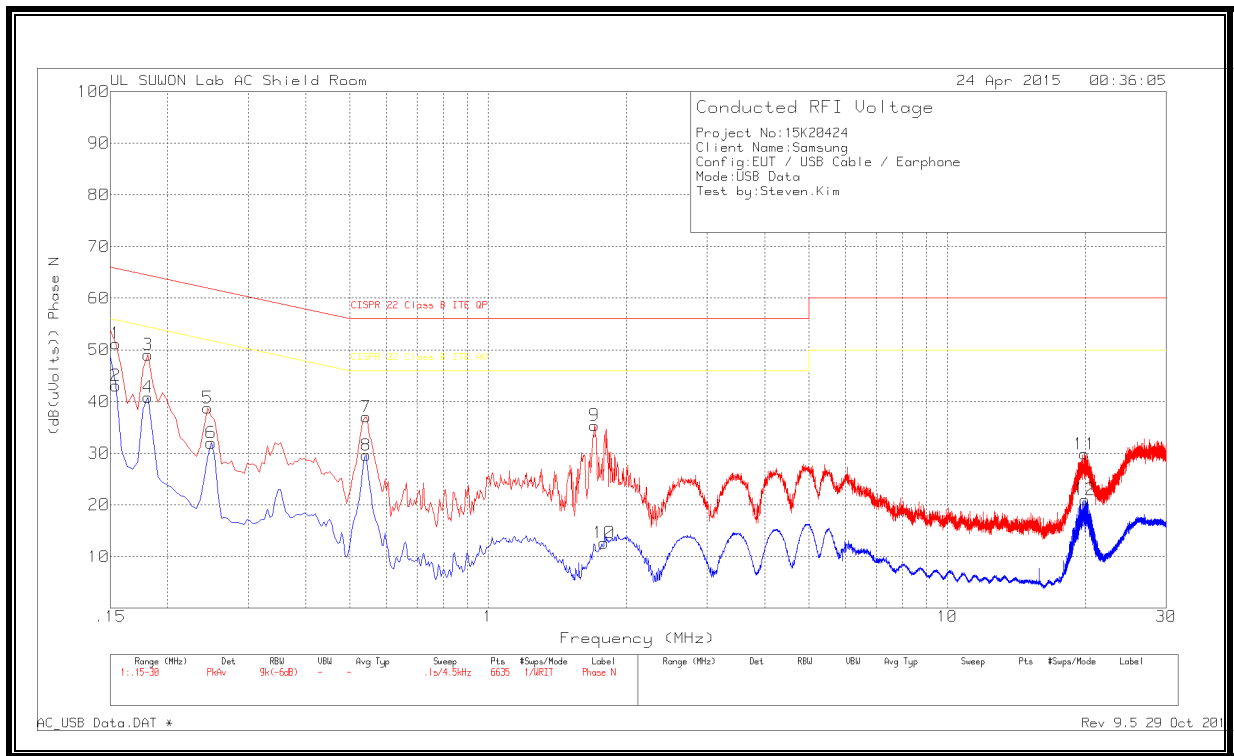

LINE 1 RESULTS

Line-L1 .15 - 30MHz

Marker	Frequency (MHz)	Meter Reading (dBuV)	Det	101837_N	CE Shield Room	Corrected Reading (dBuV)	CISPR 22 Class B ITE QP	Margin (dB)	CISPR 22 Class B ITE AV	Margin (dB)
1	.1545	41.43	Pk	9.8	0	51.23	65.75	-14.52	-	-
2	.1545	33.29	Av	9.8	0	43.09	-	-	55.75	-12.66
3	.1815	38.95	Pk	10.1	0	49.05	64.42	-15.37	-	-
4	.1815	30.75	Av	10.1	0	40.85	-	-	54.42	-13.57
5	.2445	28.87	Pk	9.9	0	38.77	61.94	-23.17	-	-
6	.249	22.11	Av	9.9	0	32.01	-	-	51.79	-19.78
7	.5415	26.92	Pk	10.1	0	37.02	56	-18.98	-	-
8	.5415	19.52	Av	10.1	0	29.62	-	-	46	-16.38
9	1.7025	25.48	Pk	9.8	.1	35.38	56	-20.62	-	-
10	1.788	2.76	Av	9.8	.1	12.66	-	-	46	-33.34
11	19.923	19.87	Pk	9.8	.2	29.87	60	-30.13	-	-
12	19.959	11.01	Av	9.8	.2	21.01	-	-	50	-28.99

Pk - Peak detector
 Av - Average detection

Line-L2 .15 - 30MHz

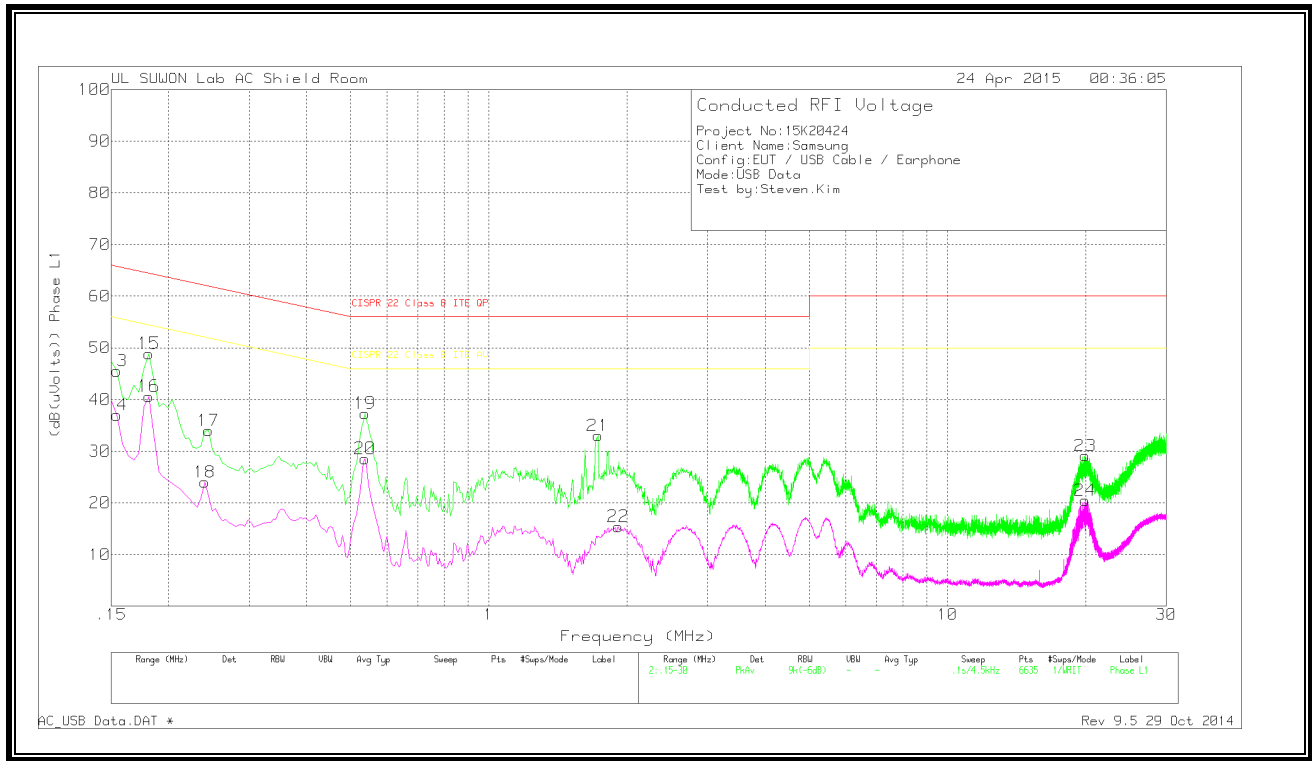

LINE 2 RESULTS

Line-L2 .15 - 30MHz

Phase L1 .15 - 30MHz										
Marker	Frequency (MHz)	Meter Reading (dBuV)	Det	101837_L 1	CE Shield Room	Corrected Reading (dBuV)	CISPR 22 Class B ITE QP	Margin (dB)	CISPR 22 Class B ITE AV	Margin (dB)
13	.1545	35.83	Pk	9.7	0	45.53	65.75	-20.22	-	-
14	.1545	27.3	Av	9.7	0	37	-	-	55.75	-18.75
15	.1815	39.08	Pk	9.8	0	48.88	64.42	-15.54	-	-
16	.1815	30.81	Av	9.8	0	40.61	-	-	54.42	-13.81
17	.2445	24.3	Pk	9.7	0	34	61.94	-27.94	-	-
18	.24	14.31	Av	9.7	0	24.01	-	-	52.1	-28.09
19	.537	27.31	Pk	10	0	37.31	56	-18.69	-	-
20	.537	18.55	Av	10	0	28.55	-	-	46	-17.45
21	1.7295	23.54	Pk	9.4	.1	33.04	56	-22.96	-	-
22	1.914	5.91	Av	9.4	.1	15.41	-	-	46	-30.59
23	19.986	19.51	Pk	9.4	.2	29.11	60	-30.89	-	-
24	19.959	10.9	Av	9.4	.2	20.5	-	-	50	-29.5

Pk - Peak detector
 Av - Average detection