



FCC 47 CFR PART 15 SUBPART E

CERTIFICATION TEST REPORT

FOR

Tablet with Bluetooth, DTS/UNII a/b/g/n, and ANT+

MODEL NUMBER: SM-T333

FCC ID: A3LSMT333

IC: 649E-SMT333

REPORT NUMBER: 15I19760-E4, REVISION B

ISSUE DATE: FEB 3, 2015

Prepared for

**SAMSUNG ELECTRONICS CO., LTD.
129 SAMSUNG-RO, YEONGTONG-GU
SUWON-CITY, GYEONGGI-DO 443-742, SOUTH KOREA**

Prepared by

**UL VERIFICATION SERVICES INC.
47173 BENICIA STREET
FREMONT, CA 94538, U.S.A.
TEL: (510) 771-1000
FAX: (510) 661-0888**



NVLAP LAB CODE 200065-0

Revision History

Rev.	Date	Revisions	Revised By
--	01/28/15	Initial Issue	P. ZHANG
A	2/2/15	Updated Model Number	L. Nguyen
B	2/3/15	Updated page 221, 232, 235.	P. ZHANG

TABLE OF CONTENTS

1. ATTESTATION OF TEST RESULTS.....	6
2. TEST METHODOLOGY	7
3. FACILITIES AND ACCREDITATION.....	7
4. CALIBRATION AND UNCERTAINTY	7
4.1. MEASURING INSTRUMENT CALIBRATION	7
4.2. SAMPLE CALCULATION.....	7
4.3. MEASUREMENT UNCERTAINTY	8
5. EQUIPMENT UNDER TEST	9
5.1. DESCRIPTION OF EUT.....	9
5.2. MAXIMUM OUTPUT POWER.....	9
5.3. DESCRIPTION OF AVAILABLE ANTENNAS.....	9
5.4. WORST-CASE CONFIGURATION AND MODE.....	10
5.5. DESCRIPTION OF TEST SETUP.....	11
6. TEST AND MEASUREMENT EQUIPMENT	13
7. SUMMARY TABLE	14
8. ON TIME, DUTY CYCLE AND MEASUREMENT METHODS.....	15
9. MEASUREMENT METHOD	17
10. ANTENNA PORT TEST RESULTS	18
10.1. 6 dB BANDWIDTH.....	18
10.2. 26 dB BANDWIDTH.....	22
10.3. 99% BANDWIDTH.....	35
10.3.1. 802.11a MODE IN THE 5.2 GHz BAND.....	36
10.3.2. 802.11n HT20 MODE IN THE 5.2 GHz BAND	36
10.3.3. 802.11n HT40 MODE IN THE 5.2 GHz BAND	36
10.3.1. 802.11a MODE IN THE 5.3 GHz BAND.....	37
10.3.1. 802.11n HT20 MODE IN THE 5.3 GHz BAND	37
10.3.2. 802.11n HT40 MODE IN THE 5.3 GHz BAND	37
10.3.3. 802.11a MODE IN THE 5.5 GHz BAND.....	38
10.3.4. 802.11n HT20 MODE IN THE 5.5 GHz BAND	38
10.3.5. 802.11n HT40 MODE IN THE 5.5 GHz BAND.....	38
10.3.6. 802.11a MODE IN THE 5.8 GHz BAND.....	39
10.3.7. 802.11n HT20 MODE IN THE 5.8 GHz BAND	39

10.3.8.	802.11n HT40 MODE IN THE 5.8 GHz BAND.....	39
10.3.1.	99% BANDWIDTH PLOTS.....	40
10.4.	AVERAGE POWER.....	43
10.4.1.	802.11a MODE IN THE 5.2 GHz BAND.....	44
10.4.2.	802.11n HT20 MODE IN THE 5.2 GHz BAND.....	44
10.4.3.	802.11n HT40 MODE IN THE 5.2 GHz BAND.....	44
10.4.4.	802.11a MODE IN THE 5.3 GHz BAND.....	45
10.4.5.	802.11n HT20 MODE IN THE 5.3 GHz BAND.....	45
10.4.6.	802.11n HT40 MODE IN THE 5.3 GHz BAND.....	45
10.4.7.	802.11a MODE IN THE 5.5 GHz BAND.....	46
10.4.8.	802.11n HT20 MODE IN THE 5.5 GHz BAND.....	46
10.4.9.	802.11n HT40 MODE IN THE 5.5 GHz BAND.....	46
10.4.10.	802.11a MODE IN THE 5.8 GHz BAND.....	47
10.4.11.	802.11n HT20 MODE IN THE 5.8 GHz BAND.....	47
10.4.12.	802.11n HT40 MODE IN THE 5.8 GHz BAND.....	47
10.5.	OUTPUT POWER AND PPSD.....	48
10.5.1.	802.11a MODE IN THE 5.2 GHz BAND.....	49
10.5.2.	802.11n HT20 MODE IN THE 5.2 GHz BAND.....	50
10.5.3.	802.11n HT40 MODE IN THE 5.2 GHz BAND.....	51
	802.11a MODE IN THE 5.3 GHz BAND.....	52
10.5.4.	802.11n HT20 MODE IN THE 5.3 GHz BAND.....	53
10.5.5.	802.11n HT40 MODE IN THE 5.3 GHz BAND.....	54
	802.11a MODE IN THE 5.5 GHz BAND.....	55
10.5.6.	802.11n HT20 MODE IN THE 5.5 GHz BAND.....	56
10.5.7.	802.11n HT40 MODE IN THE 5.5 GHz BAND.....	57
	802.11a MODE IN THE 5.8 GHz BAND.....	58
10.5.8.	802.11n HT20 MODE IN THE 5.8 GHz BAND.....	59
10.5.9.	802.11n HT40 MODE IN THE 5.8 GHz BAND.....	60
10.5.10.	OUTPUT POWER AND PPSD PLOTS, Chain 0.....	61
11.	TRANSMITTER ABOVE 1 GHz.....	64
11.1.	5.2 GHz.....	65
11.1.1.	TX ABOVE 1 GHz 802.11a MODE IN THE 5.2 GHz BAND.....	65
11.1.2.	TX ABOVE 1 GHz 802.11n HT20 MODE IN THE 5.2 GHz BAND.....	76
11.1.3.	TX ABOVE 1 GHz 802.11n HT40 MODE IN THE 5.2 GHz BAND.....	87
11.2.	5.3 GHz.....	95
11.2.1.	TX ABOVE 1 GHz 802.11a MODE IN THE 5.3 GHz BAND.....	95
11.2.2.	TX ABOVE 1 GHz 802.11n HT20 MODE IN THE 5.3 GHz BAND.....	106
11.2.3.	TX ABOVE 1 GHz 802.11n HT40 MODE IN THE 5.3 GHz BAND.....	117
11.3.	5.5-5.6 GHz.....	125
11.3.1.	TX ABOVE 1 GHz 802.11a MODE IN THE 5.5 GHz BAND.....	125
11.3.2.	TX ABOVE 1 GHz 802.11n HT20 MODE IN THE 5.5 GHz BAND.....	138
11.3.3.	TX ABOVE 1 GHz 802.11n HT40 MODE IN THE 5.5 GHz BAND.....	151
11.4.	5.8 GHz.....	164
11.4.1.	TX ABOVE 1 GHz 802.11a MODE IN THE 5.8 GHz BAND.....	164

11.4.2. TX ABOVE 1 GHz 802.11n HT20 MODE IN THE 5.8 GHz BAND..... 177
11.4.3. TX ABOVE 1 GHz 802.11n HT40 MODE IN THE 5.8 GHz BAND..... 190

12. WORST-CASE BELOW 1 GHz (in the 5.3 GHz Band).....200

13. AC POWER LINE CONDUCTED EMISSIONS.....203

14. DYNAMIC FREQUENCY SELECTION.....208

14.1. OVERVIEW.....208

14.1.1. LIMITS.....208

14.1.2. TEST AND MEASUREMENT SYSTEM.....215

14.1.3. SETUP OF EUT219

14.1.4. DESCRIPTION OF EUT.....221

14.2. RESULTS FOR 20 MHz BANDWIDTH.....223

14.2.1. TEST CHANNEL.....223

14.2.2. RADAR WAVEFORM AND TRAFFIC.....223

14.2.3. OVERLAPPING CHANNEL TESTS.....225

14.2.4. MOVE AND CLOSING TIME225

14.3. RESULTS FOR 40 MHz BANDWIDTH.....230

14.3.1. TEST CHANNEL.....230

14.3.2. RADAR WAVEFORM AND TRAFFIC.....230

14.3.3. OVERLAPPING CHANNEL TESTS.....232

14.3.4. MOVE AND CLOSING TIME232

14.3.5. 10-MINUTE BEACON MONITORING PERIOD237

15. SETUP PHOTOS.....238

1. ATTESTATION OF TEST RESULTS

COMPANY NAME: SAMSUNG ELECTRONICS CO., LTD.
EUT DESCRIPTION: Tablet with Bluetooth, DTS/UNII a/b/g/n, and ANT+
MODEL NUMBER: SM-T333
SERIAL NUMBER: 2033413 (Conducted); 20333416 (Radiated)
DATE TESTED: JANUARY 12-20, 2015

APPLICABLE STANDARDS	
STANDARD	TEST RESULTS
CFR 47 Part 15 Subpart E	Pass

UL Verification Services Inc. tested the above equipment in accordance with the requirements set forth in the above standards. All indications of Pass/Fail in this report are opinions expressed by UL Verification Services Inc. based on interpretations and/or observations of test results. Measurement Uncertainties were not taken into account and are published for informational purposes only. The test results show that the equipment tested is capable of demonstrating compliance with the requirements as documented in this report.

Note: The results documented in this report apply only to the tested sample, under the conditions and modes of operation as described herein. This document may not be altered or revised in any way unless done so by UL Verification Services Inc. and all revisions are duly noted in the revisions section. Any alteration of this document not carried out by UL Verification Services Inc. will constitute fraud and shall nullify the document. This report must not be used by the client to claim product certification, approval, or endorsement by NVLAP, NIST, any agency of the Federal Government, or any agency of any government.

Approved & Released For
UL Verification Services Inc. By:

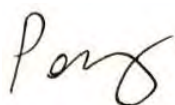

PENG ZHANG
CONSUMER TECHNOLOGY DIVISION
PROJECT LEAD
UL Verification Services Inc.

Tested By:



CHARLES VERGONIO
CONSUMER TECHNOLOGY DIVISION
LAB ENGINEER
UL Verification Services Inc.

2. TEST METHODOLOGY

The tests documented in this report were performed in accordance with FCC CFR 47 Part 2, FCC CFR 47 Part 15, ANSI C63.4-2009.

789033 D02 General UNII Test Procedures New Rules v01

The tests documented in this report were performed in accordance with the DFS portion of FCC CFR 47 Part 2, FCC CFR 47 Part 15, FCC 06-96, FCC KDB 789033, KDB 905462 D02 and D03, ANSI C63.10-2009.

3. FACILITIES AND ACCREDITATION

The test sites and measurement facilities used to collect data are located at 47173 and 47266 Benicia Street, Fremont, California, USA. Line conducted emissions are measured only at the 47173 address. The following table identifies which facilities were utilized for radiated emission measurements documented in this report. Specific facilities are also identified in the test results sections.

47173 Benicia Street	47266 Benicia Street
<input type="checkbox"/> Chamber A(IC: 2324B-1)	<input type="checkbox"/> Chamber D(IC: 2324B-4)
<input checked="" type="checkbox"/> Chamber B(IC: 2324B-2)	<input type="checkbox"/> Chamber E(IC: 2324B-5)
<input checked="" type="checkbox"/> Chamber C(IC: 2324B-3)	<input type="checkbox"/> Chamber F(IC: 2324B-6)
	<input type="checkbox"/> Chamber G(IC: 2324B-7)
	<input type="checkbox"/> Chamber H(IC: 2324B-8)

UL Verification Services Inc. is accredited by NVLAP, Laboratory Code 200065-0. The full scope of accreditation can be viewed at <http://ts.nist.gov/standards/scopes/2000650.htm>.

4. CALIBRATION AND UNCERTAINTY

4.1. MEASURING INSTRUMENT CALIBRATION

The measuring equipment utilized to perform the tests documented in this report has been calibrated in accordance with the manufacturer's recommendations, and is traceable to recognized national standards.

4.2. SAMPLE CALCULATION

Where relevant, the following sample calculation is provided:

$$\begin{aligned} \text{Field Strength (dBuV/m)} &= \text{Measured Voltage (dBuV)} + \text{Antenna Factor (dB/m)} + \\ &\text{Cable Loss (dB)} - \text{Preamp Gain (dB)} \\ 36.5 \text{ dBuV} + 18.7 \text{ dB/m} + 0.6 \text{ dB} - 26.9 \text{ dB} &= 28.9 \text{ dBuV/m} \end{aligned}$$

4.3. MEASUREMENT UNCERTAINTY

Where relevant, the following measurement uncertainty levels have been estimated for tests performed on the apparatus:

PARAMETER	UNCERTAINTY
Conducted Disturbance, 0.15 to 30 MHz	3.52 dB
Radiated Disturbance, 30 to 40000 MHz	4.94 dB

Uncertainty figures are valid to a confidence level of 95%.

5. EQUIPMENT UNDER TEST

5.1. DESCRIPTION OF EUT

The EUT is a TABLET + BLUETOOTH, DTS/UNII a/b/g/n & ANT+.

5.2. MAXIMUM OUTPUT POWER

The transmitter has a maximum conducted output power as follows:

Frequency Range (MHz)	Mode	Total Output Power (dBm)	Total Output Power (mW)
5180 - 5240	802.11a	10.8	12.02
5180 - 5240	802.11n HT20	10.44	11.07
5190 - 5230	802.11n HT40	10.24	10.57
5260 - 5320	802.11a	10.75	11.89
5260 - 5320	802.11n HT20	10.76	11.91
5270 - 5310	802.11n HT40	10.2	10.47
5500 - 5700	802.11a	10.59	11.46
5500 - 5700	802.11n HT20	10.15	10.35
5510 - 5670	802.11n HT40	10.8	12.02
5745 - 5825	802.11a	10.51	11.25
5745 - 5825	802.11n HT20	10.51	11.25
5755 - 5795	802.11n HT40	10.47	11.14

5.3. DESCRIPTION OF AVAILABLE ANTENNAS

The radio utilizes an FPCB antenna, with a maximum gain of -0.5 dBi.

5.4. WORST-CASE CONFIGURATION AND MODE

Radiated emission and power line conducted emission were performed with the EUT set to transmit at the channel with highest output power as worst-case scenario.

The fundamental of the EUT was investigated in three orthogonal orientations X, Y, Z it was determined that the X orientation was worst-case orientation; therefore, all final radiated testing was performed with the EUT in the X orientation.

Based on the baseline scan, the worst-case data rates were:

802.11a mode: 6 Mbps

802.11n HT20mode: MCS0

802.11n HT40mode: MCS0

5.5. DESCRIPTION OF TEST SETUP

SUPPORT EQUIPMENT

Support Equipment List				
Description	Manufacturer	Model	Serial Number	FCC ID
AC Adapter	SAMSUNG	ETA0U81EWE	N/A	N/A
Earphone	SAMSUNG	N/A	N/A	N/A

I/O CABLES

I/O Cable List						
Cable No	Port	# of identical ports	Connector Type	Cable Type	Cable Length (m)	Remarks
1	DC Power	1	Mini-USB	Shielded	1.2m	N/A
2	Audio	1	Mini-Jack	Unshielded	1.0m	N/A

TEST SETUP

EUT was set in the Hidden menu mode to enable WLAN UNII communications.

SETUP DIAGRAM FOR TESTS

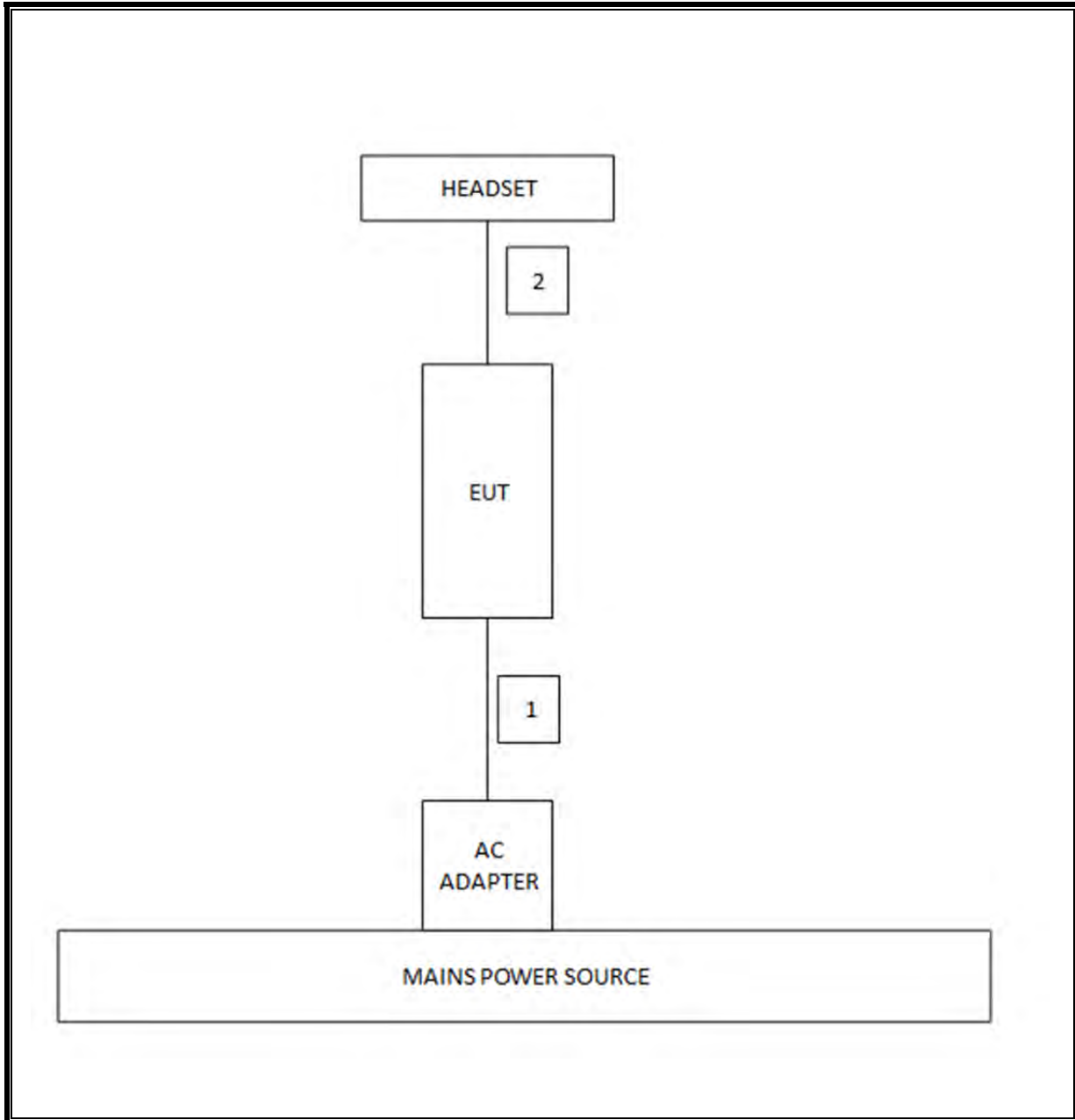

6. TEST AND MEASUREMENT EQUIPMENT

The following test and measurement equipment was utilized for the tests documented in this report:

Test Equipment List				
Description	Manufacturer	Model	Asset	Cal Due
Antenna, Biconolog, 30MHz-1 GHz	Sunol Sciences	JB1	C01171	02/13/15
Antenna, Horn, 18GHz	EMCO	3115	C00783	10/25/15
Antenna, Horn, 26.5 GHz	ARA	MWH-1826/B	C00980	11/14/15
Preamplifier, 1300 MHz	Agilent / HP	8447D	C00580	01/28/15
Preamplifier, 26.5 GHz	Agilent / HP	8449B	C01052	10/22/15
Spectrum Analyzer, 44 GHz	Agilent / HP	E4446A	C01069	12/20/15
CBT Bluetooth Tester	R & S	CBT	None	07/12/15
Peak Power Meter	Agilent / HP	E4416A	C00963	12/13/15
Peak / Average Power Sensor	Agilent / HP	E9327A	C00964	12/13/15
LISN, 30 MHz	FCC	50/250-25-2	C00626	01/14/15
Reject Filter, 2.4GHz	Micro-Tronics	BRM50702	N02684	CNR
Peak Power Meter	Agilent / HP	E4416A	C00963	12/13/15
Peak / Average Power Sensor	Agilent / HP	E9327A	C00964	12/13/15

7. SUMMARY TABLE

FCC Part Section	Test Description	Test Limit	Test Condition	Test Result	Worst Case
15.407 (a)	Occupied Band width (26dB)	N/A	Conducted	Pass	44.88MHz
15.407	6dB Band width (5.8Ghz)	500KHz		Pass	16.41MHz
15.407 (a)(2)	TX Cond. Power 5.15-2.25, 5.25-5.35 & 5.47-5.725	<24dBm or 11+10Log(OBW)		Pass	10.8dBm
15.407 (a)(3)	TX Cond. Power 5.725-5.825	< 30dBm or 17+10Log(OBW)		Pass	10.51dBm
15.407 (a)(5)	PSD (5.2GHz); PSD(5.3,5.5GHz)	<11dBm		Pass	-0.57dBm
15.407 (a)(5)	PSD (5.8GHz)	30dBm per 500kHz		Pass	-3.05dBm
15.207 (a)	AC Power Line conducted emissions	Section 10	Radiated	Pass	46.21dBuV(PK)
15.407 (b) & 15.209	Radiated Spurious Emission	< 54dBuV/m		Pass	53.9dBuV/m
15.407 (h)(2)	Dynamic Frequency Selection	N/A	Radiated / Condcuted	Pass	N/A

8. ON TIME, DUTY CYCLE AND MEASUREMENT METHODS

LIMITS

None; for reporting purposes only.

PROCEDURE

KDB 789033 Zero-Span Spectrum Analyzer Method.

RESULTS

ON TIME AND DUTY CYCLE RESULT AND PLOTS

Mode	ON Time B (msec)	Period (msec)	Duty Cycle x (linear)	Duty Cycle (%)	Duty Cycle Correction Factor (dB)	1/T Minimum VBW (kHz)
802.11a	1.40	1.50	0.928	92.8%	0.32	0.717
802.11n HT20	1.30	1	0.927	92.7%	0.33	0.772
802.11n HT40	0.63	1	0.863	86.3%	0.64	1.575

DUTY CYCLE 802.11a MODE

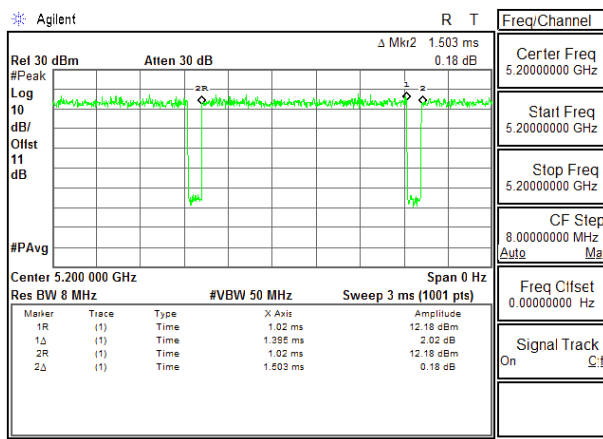

DUTY CYCLE 802.11n HT20 MODE

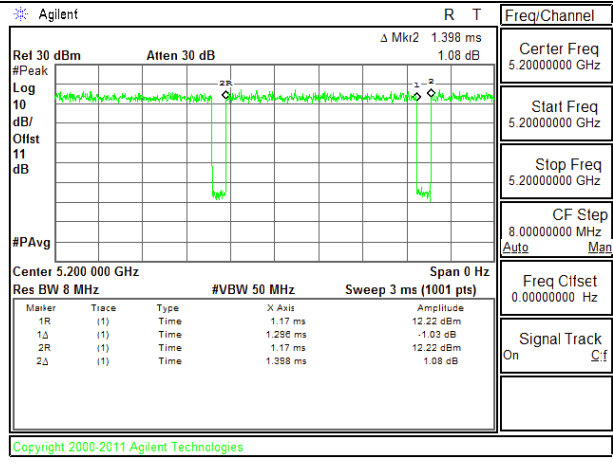

DUTY CYCLE 802.11n HT40 MODE

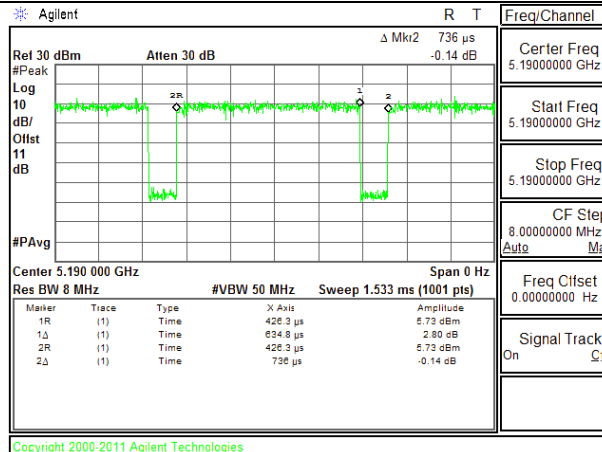

NOTE:

9. MEASUREMENT METHOD

789033 D02 General UNII Test Procedures New Rules v01

The Duty Cycle is less than 98% and consistent therefore KDB 789033 Method SA-2 is used for power and PPSD

The Duty Cycle is less than 98% and consistent, KDB 789033 Method AD with Power RMS Averaging and duty cycle correction is used.

10. ANTENNA PORT TEST RESULTS

10.1.6 dB BANDWIDTH

LIMITS

FCC §15.407

IC RSS-210 A8.2 (a)

The minimum 6 dB bandwidth shall be at least 500 kHz.

TEST PROCEDURE

Reference to 789033 D02 General UNII Test Procedures New Rules v01: The transmitter output is connected to a spectrum analyzer with the RBW set to 100KHz, the VBW $\geq 3 \times$ RBW, peak detector and max hold.

RESULTS

6 dB BANDWIDTH PLOTS AND TABLE

802.11a MODE IN THE 5.8 GHz BAND TEST RESULT TABLE

Channel	Frequency (MHz)	6 dB Bandwidth (MHz)	Minimum Limit (MHz)
Low	5745	16.410	0.5
Mid	5785	16.410	0.5
High	5825	16.440	0.5
Worst		16.440	

11a 5.8 Low Channel

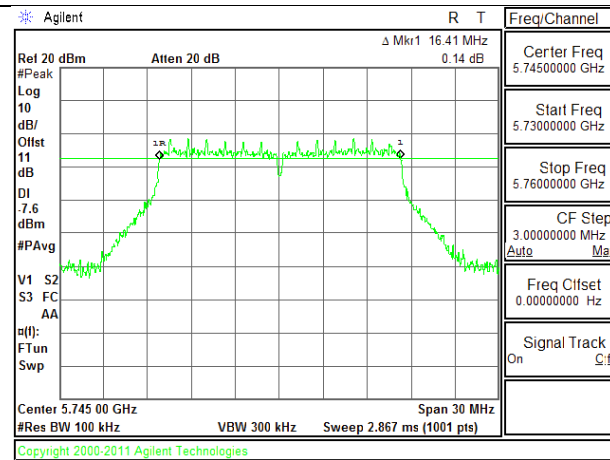

11a 5.8 Mid Channel

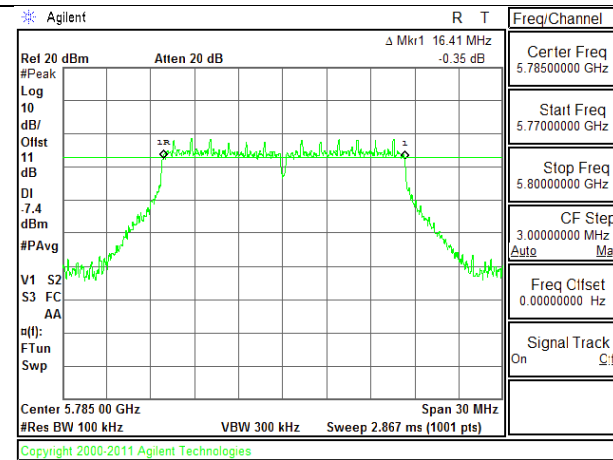

11a 5.8 High Channel

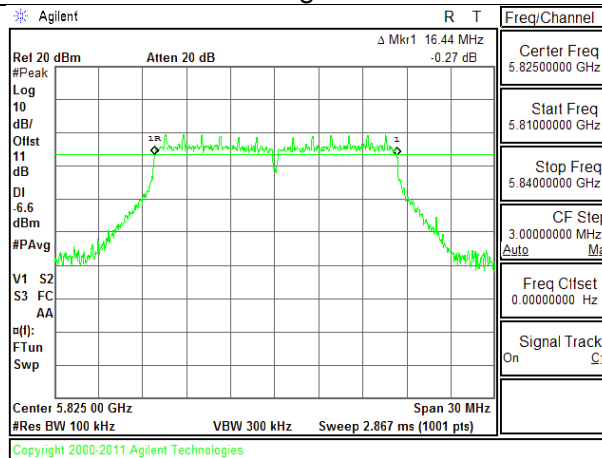

NOTE:

802.11n HT20 MODE IN THE 5.8 GHz BAND TEST RESULT TABLE

Channel	Frequency (MHz)	6 dB Bandwidth (MHz)	Minimum Limit (MHz)
Low	5745	17.640	0.5
Mid	5785	17.640	0.5
High	5825	17.640	0.5
Worst		17.640	

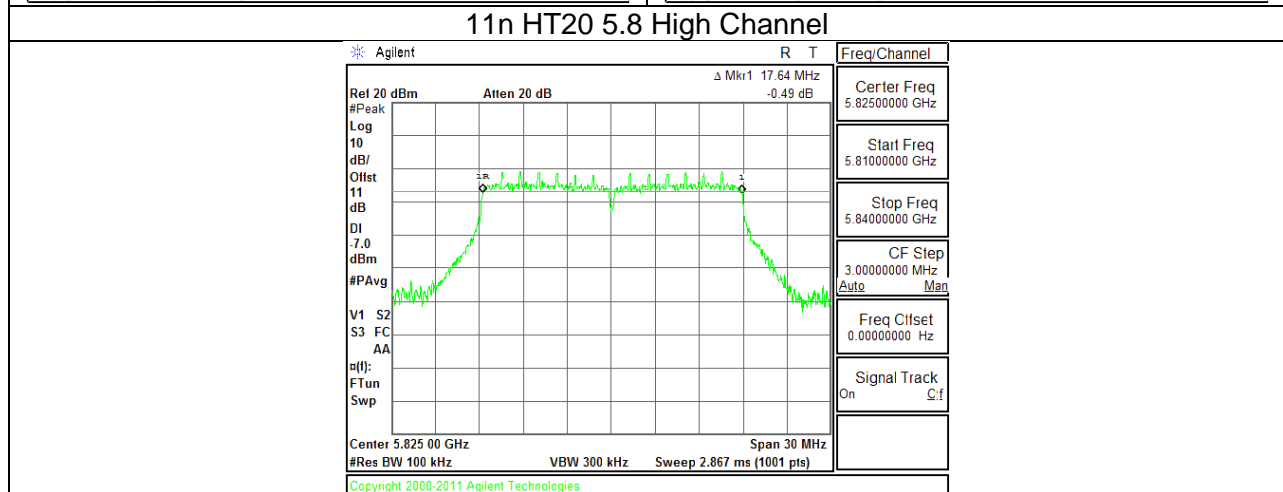
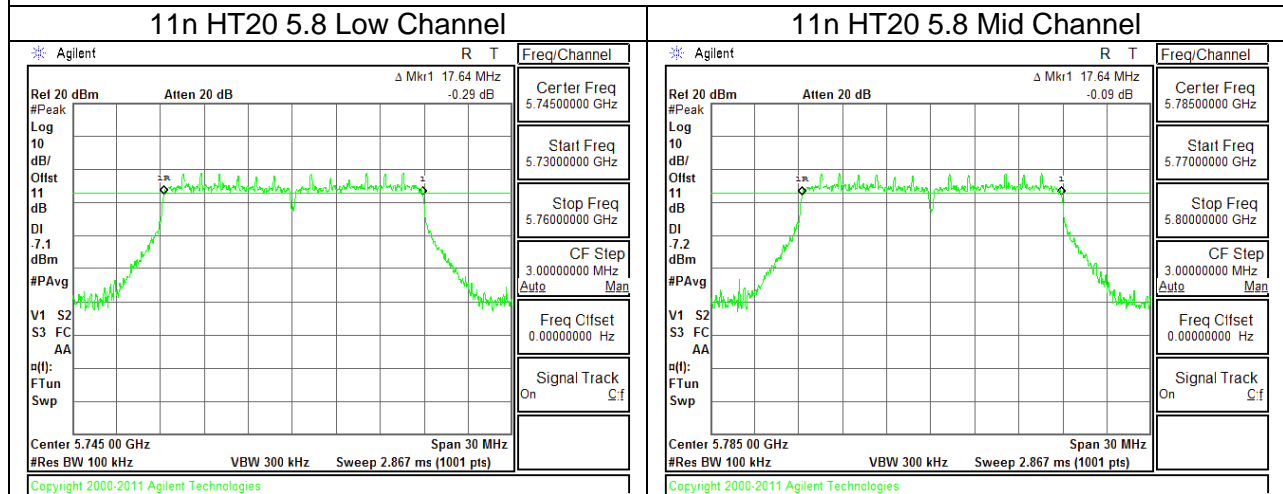

NOTE:

802.11n HT40 MODE IN THE 5.8 GHz BAND TEST RESULT TABLE

Channel	Frequency (MHz)	6 dB Bandwidth (MHz)	Minimum Limit (MHz)
Low	5755	35.820	0.5
High	5795	35.820	0.5
Worst		35.820	

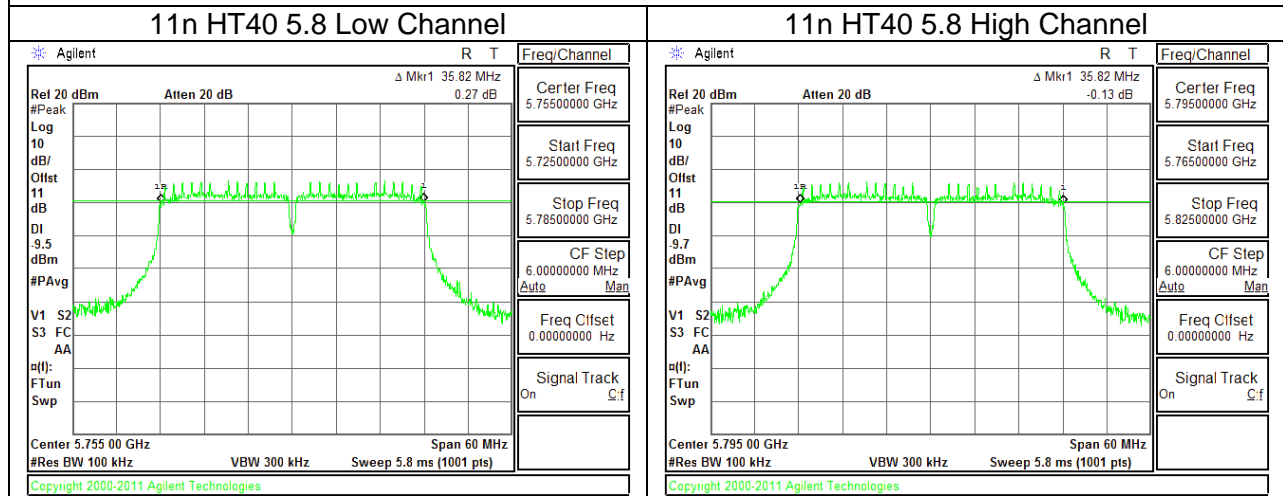

Intentionally blank

NOTE:

10.2. 26 dB BANDWIDTH

LIMITS

None; for reporting purposes only.

RESULTS

26 dB BANDWIDTH PLOTS AND TABLE

802.11a MODE IN THE 5.2 GHz BAND TEST RESULT TABLE

Channel	Frequency (MHz)	26 dB Bandwidth (MHz)
Low	5180	22.32
Mid	5200	21.60
High	5240	21.87
Worst		22.32

11a 5.2 Low Channel

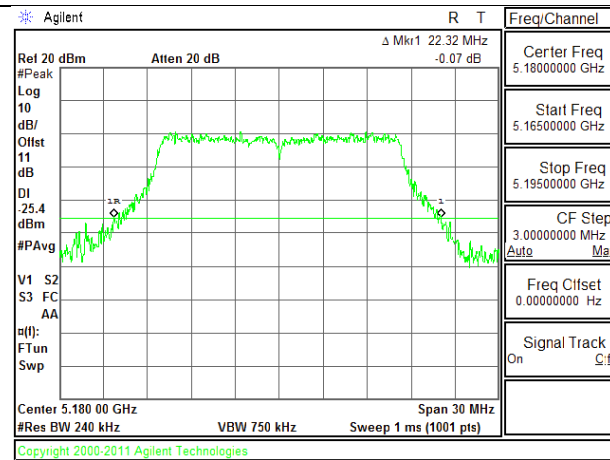

11a 5.2 Mid Channel

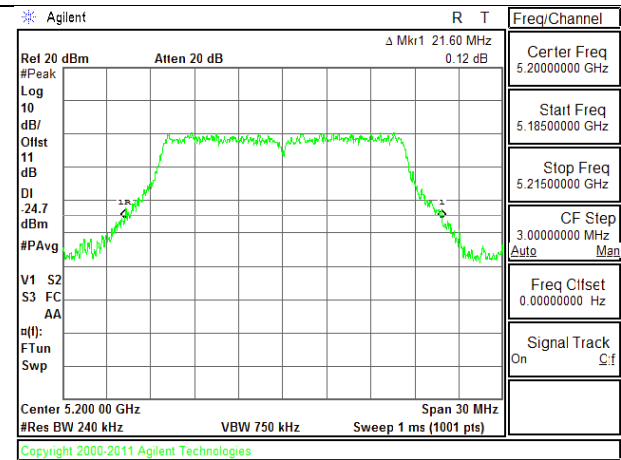

11a 5.2 High Channel

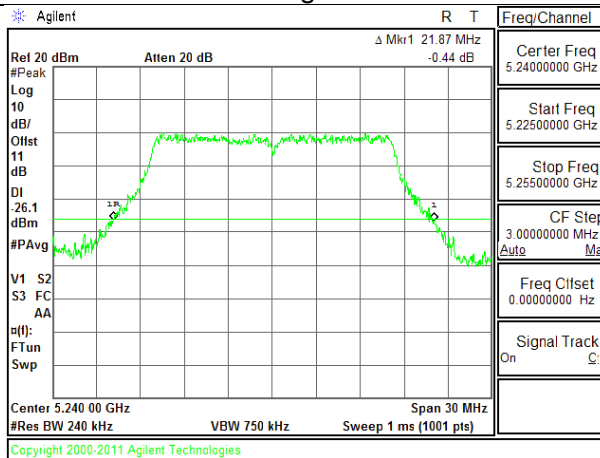

NOTE:

802.11n HT20 MODE IN THE 5.2 GHz BAND TEST RESULT TABLE

Channel	Frequency (MHz)	26 dB Bandwidth (MHz)
Low	5180	21.99
Mid	5200	22.41
High	5240	22.08
Worst		22.41

11n HT20 5.2 Low Channel

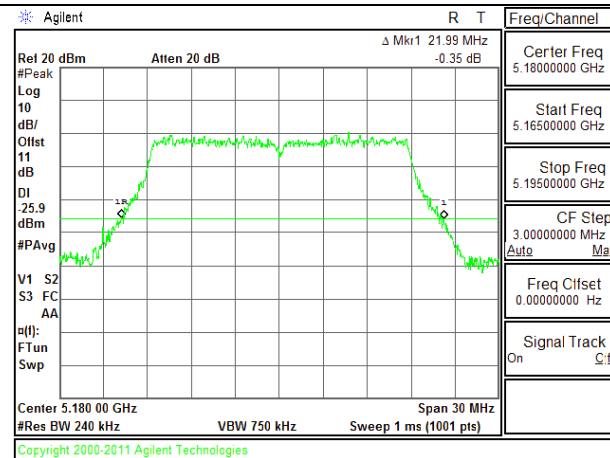

11n HT20 5.2 Mid Channel

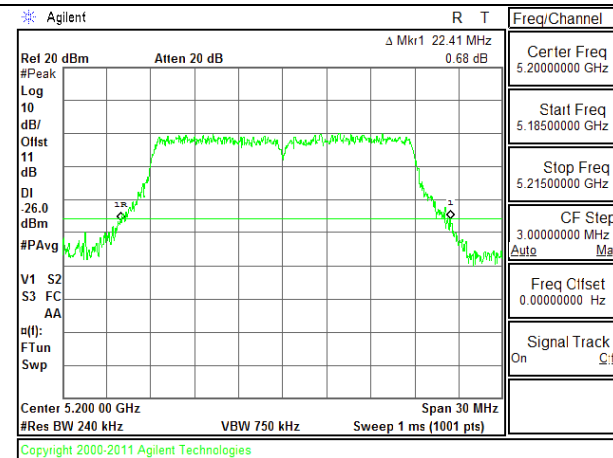

11n HT20 5.2 High Channel

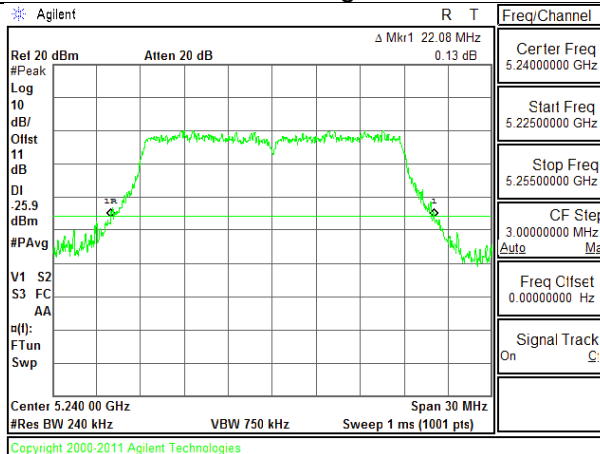

NOTE:

802.11n HT40 MODE IN THE 5.2 GHz BAND TEST RESULT TABLE

Channel	Frequency (MHz)	26dB Bandwidth (MHz)
Low	5190	43.92
Mid	5230	44.88
Worst		44.88

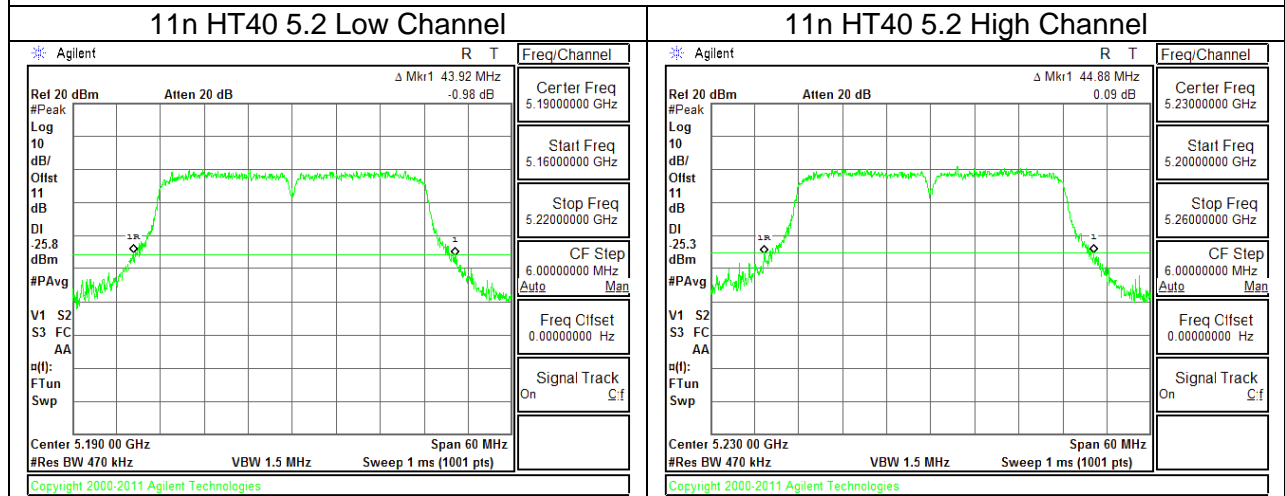

Intentionally blank

NOTE:

802.11a MODE IN THE 5.3 GHz BAND TEST RESULT TABLE

Channel	Frequency (MHz)	26 dB Bandwidth (MHz)
Low	5260	22.14
Mid	5300	22.29
High	5320	22.17
Worst		22.29

11a 5.3 Low Channel

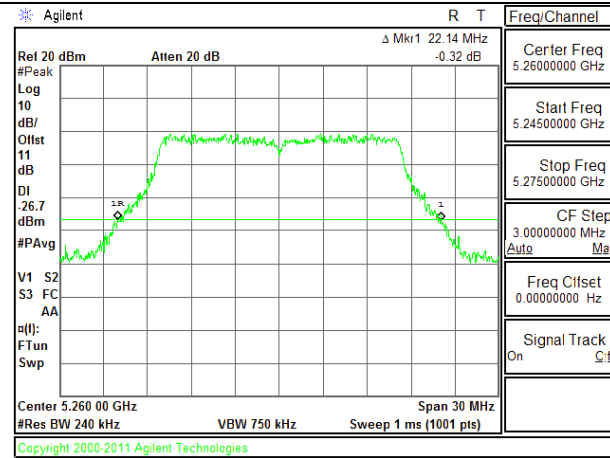

11a 5.3 Mid Channel

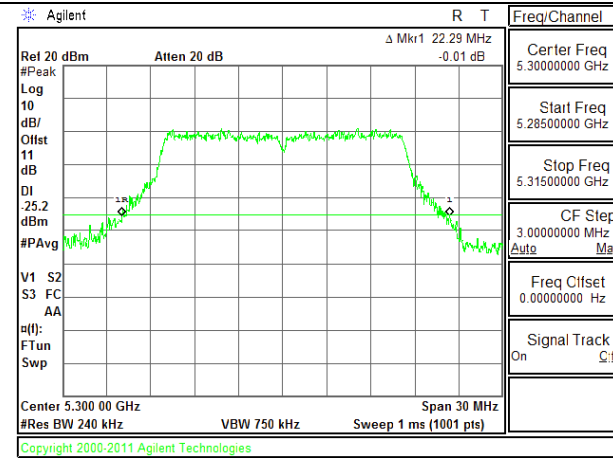

11a 5.3 High Channel

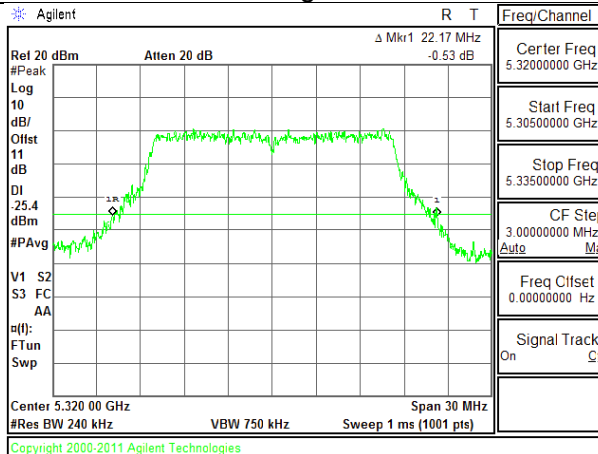

NOTE:

802.11n HT20 MODE IN THE 5.3 GHz BAND TEST RESULT TABLE

Channel	Frequency (MHz)	26 dB Bandwidth (MHz)
Low	5260	22.05
Mid	5300	22.68
High	5320	21.99
Worst		22.68

11n HT20 5.3 Low Channel

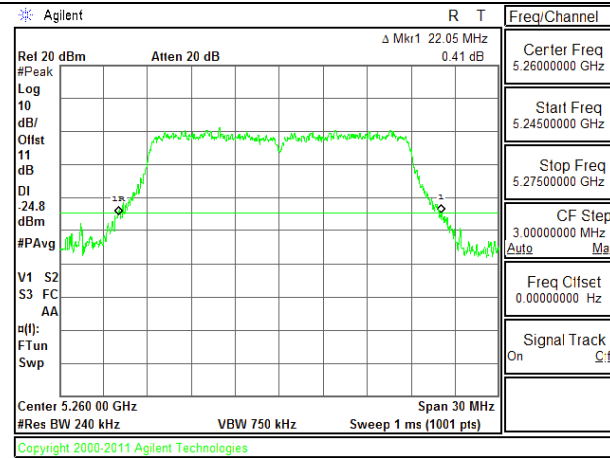

11n HT20 5.3 Mid Channel

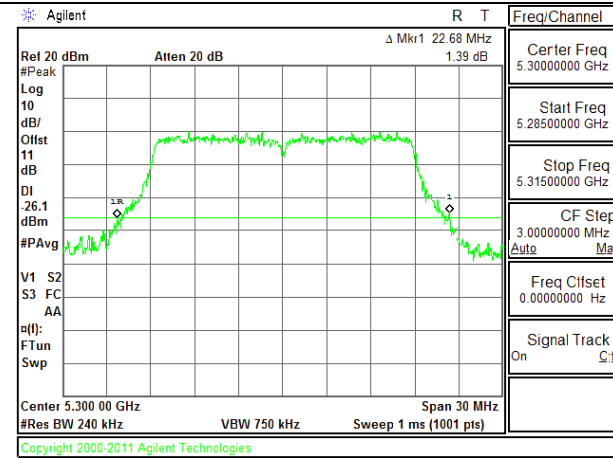

11n HT20 5.3 High Channel

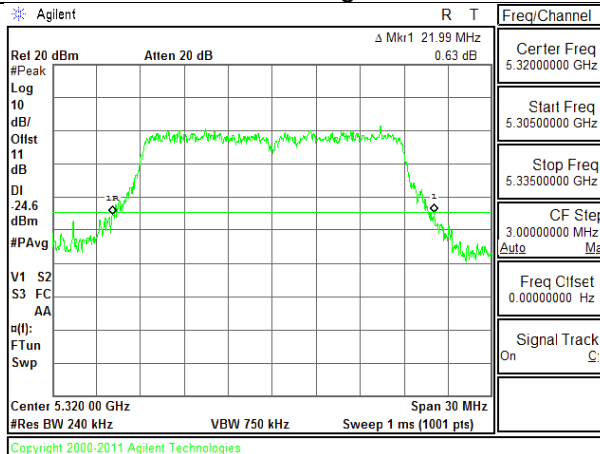

NOTE:

802.11n HT40 MODE IN THE 5.3 GHz BAND TEST RESULT TABLE

Channel	Frequency (MHz)	26 dB Bandwidth (MHz)
Low	5270	43.20
High	5310	44.10
Worst		44.10

11n HT40 5.3 Low Channel

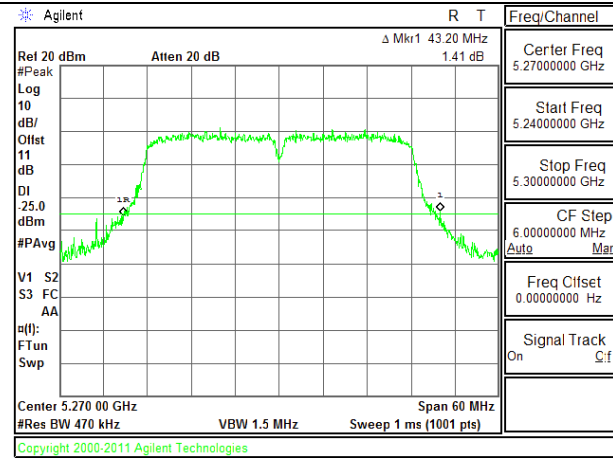

11n HT20 5.3 High Channel

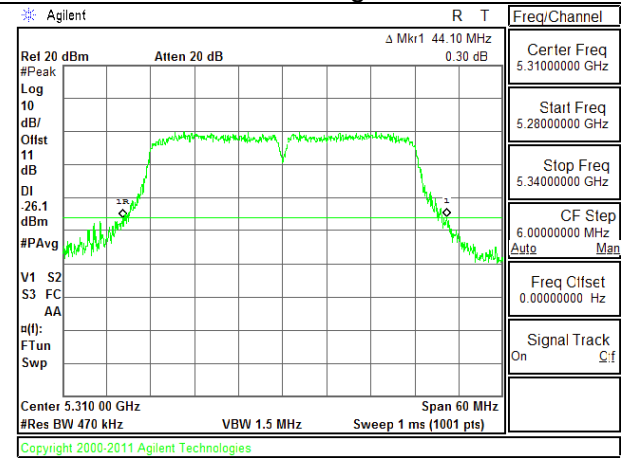

Intentionally blank

NOTE:

802.11a MODE IN THE 5.5 GHz BAND TEST RESULT TABLE

Channel	Frequency (MHz)	26 dB Bandwidth (MHz)
Low	5500	22.98
Mid	5580	22.17
High	5700	21.78
Worst		22.98

11a 5.5 Low Channel

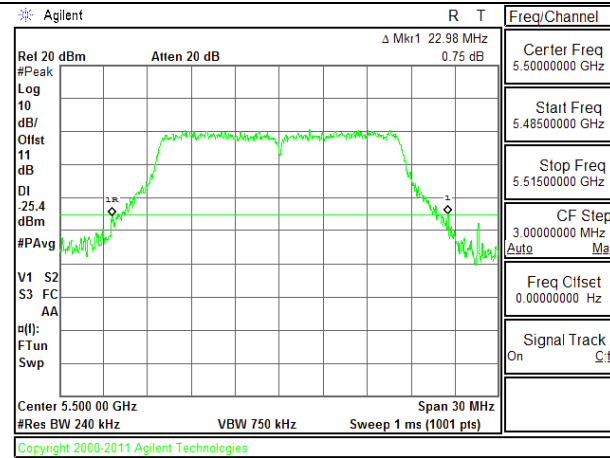

11a 5.5 Mid Channel

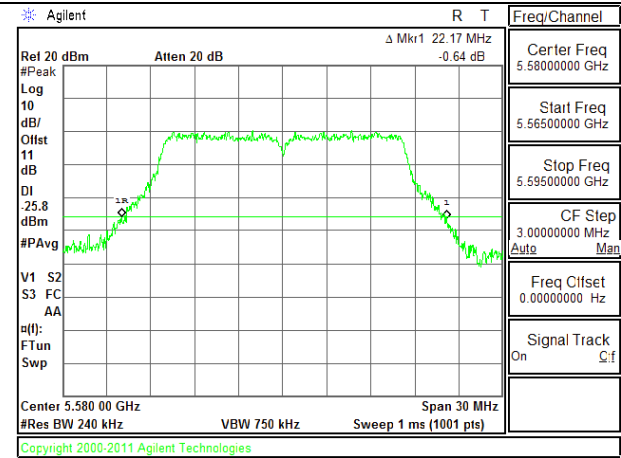

11a 5.5 High Channel

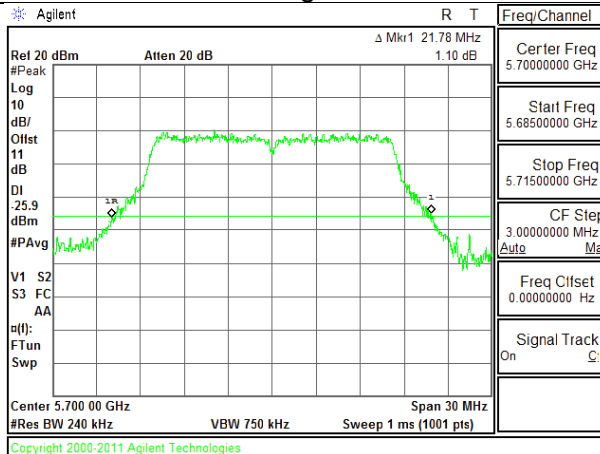

NOTE:

802.11n HT20 MODE IN THE 5.5 GHz BAND TEST RESULT TABLE

Channel	Frequency (MHz)	26 dB Bandwidth (MHz)
Low	5500	22.20
Mid	5580	22.32
High	5700	22.50
Worst		22.50

11n HT20 5.5 Low Channel

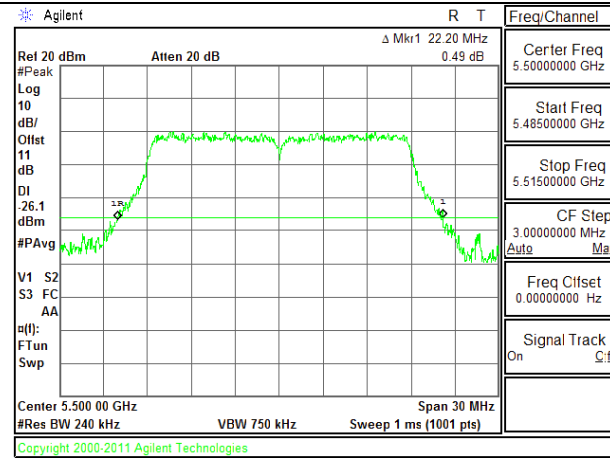

11n HT20 5.5 Mid Channel

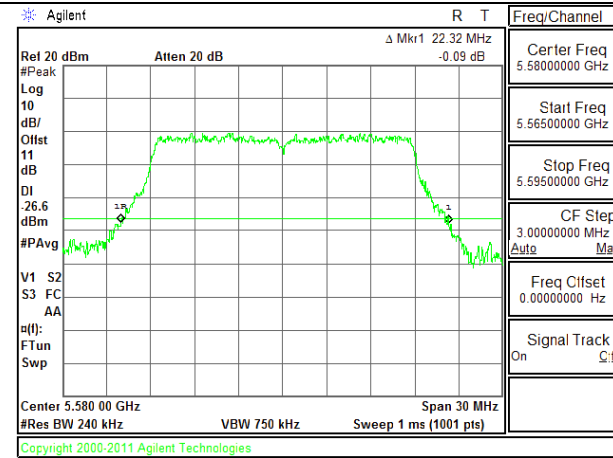

11n HT20 5.5 High Channel

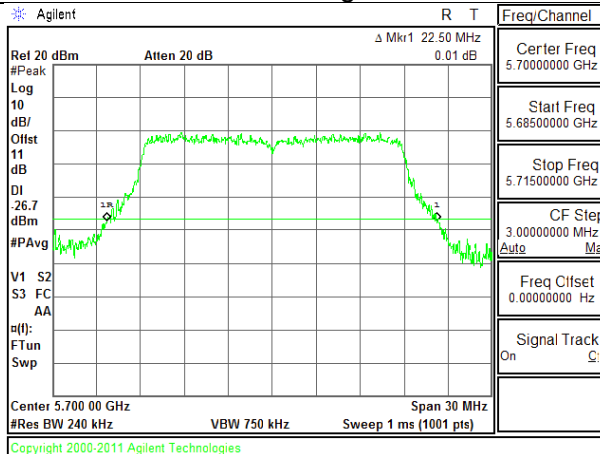

NOTE:

802.11n HT40 MODE IN THE 5.5 GHz BAND TEST RESULT TABLE

Channel	Frequency (MHz)	26 dB Bandwidth (MHz)
Low	5510	44.04
Mid	5550	44.22
High	5670	44.28
Worst		44.28

11n HT40 5.5 Low Channel

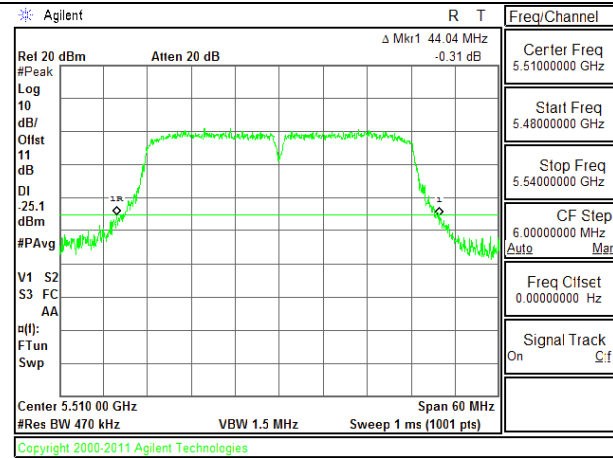

11n HT40 5.5 Mid Channel

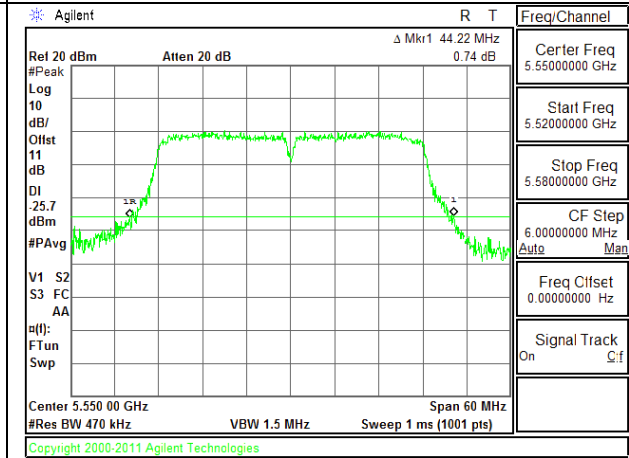

11n HT40 5.5 High Channel

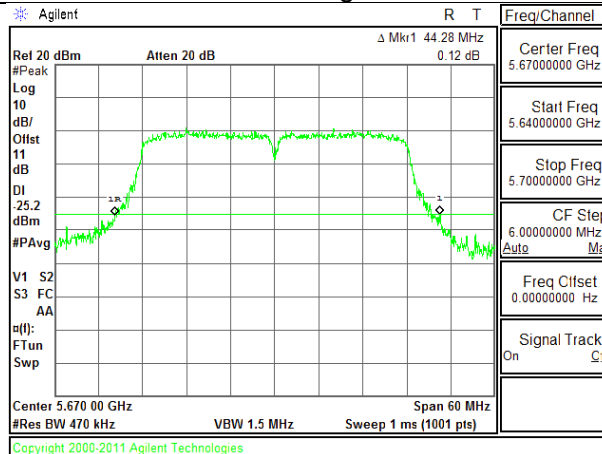

NOTE:

802.11a MODE IN THE 5.8 GHz BAND TEST RESULT TABLE

Channel	Frequency (MHz)	26 dB Bandwidth (MHz)
Low	5745	22.29
Mid	5785	22.08
High	5825	22.23
Worst		22.29

11a 5.8 Low Channel

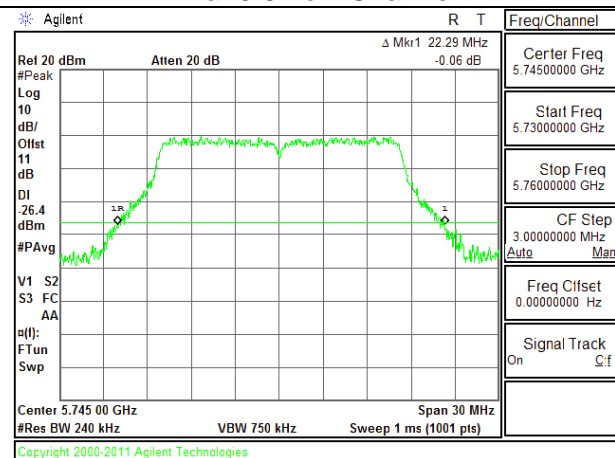

11a 5.8 Mid Channel

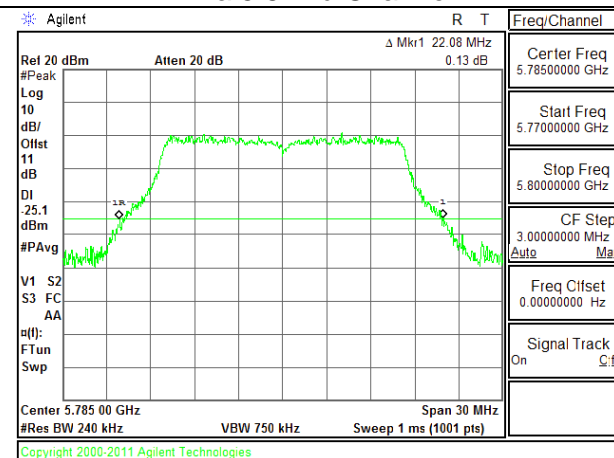

11a 5.8 High Channel

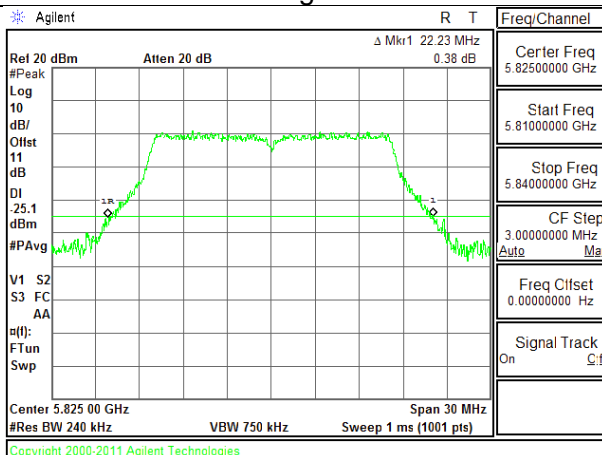

NOTE:

802.11n HT20 MODE IN THE 5.8 GHz BAND TEST RESULT TABLE

Channel	Frequency (MHz)	26 dB Bandwidth (MHz)
Low	5745	21.99
Mid	5785	22.32
High	5825	22.47
Worst		22.47

11n HT20 5.8 Low Channel

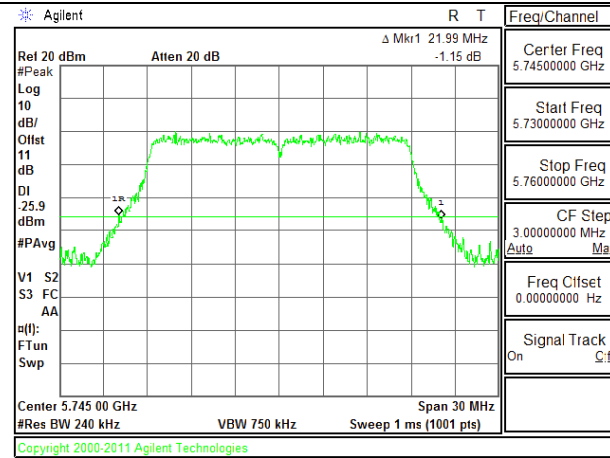

11n HT20 5.8 Mid Channel

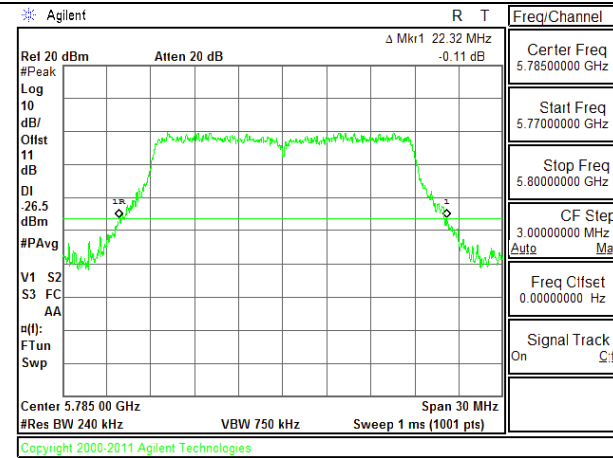

11n HT20 5.8 High Channel

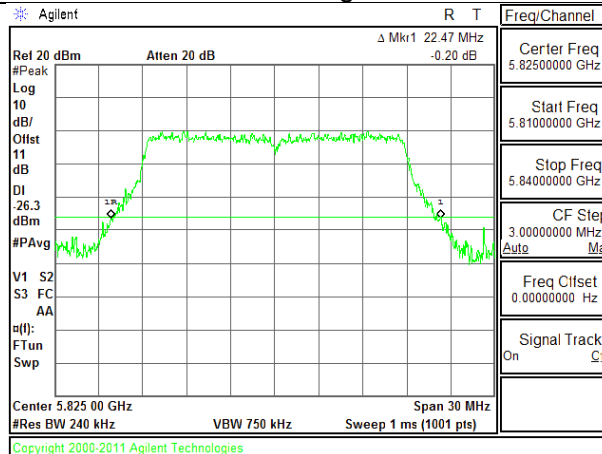

NOTE:

802.11n HT40 MODE IN THE 5.8 GHz BAND TEST RESULT TABLE

Channel	Frequency (MHz)	26 dB Bandwidth (MHz)
Low	5755	44.22
High	5795	43.62
Worst		44.22

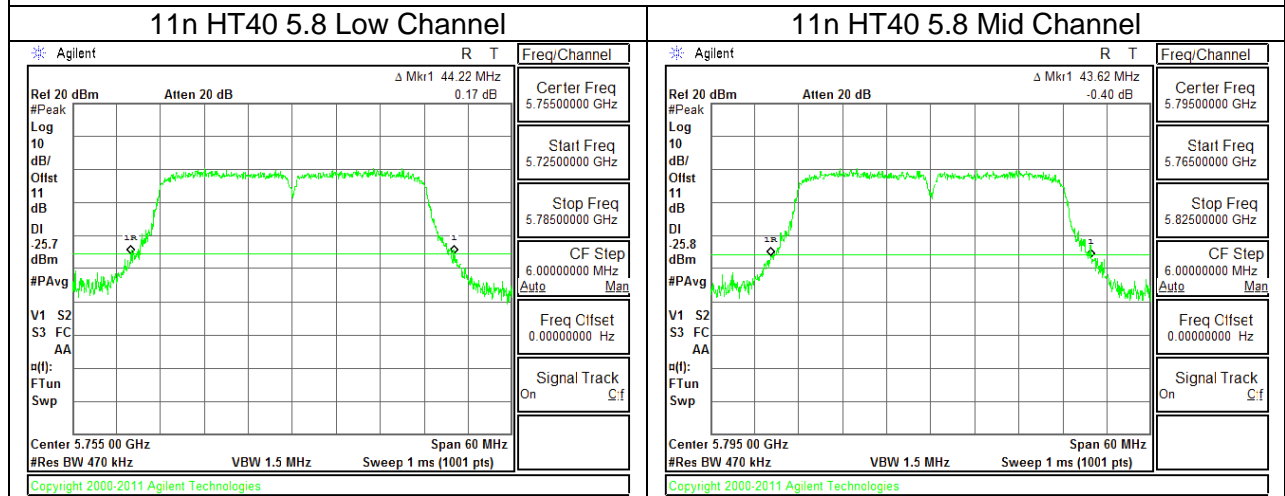

NOTE:

10.3. 99% BANDWIDTH

LIMITS

None; for reporting purposes only.

RESULTS

10.3.1. 802.11a MODE IN THE 5.2 GHz BAND

Channel	Frequency (MHz)	99% Bandwidth (MHz)
Low	5180	16.44
Mid	5200	16.56
High	5240	16.47
Worst		16.56

10.3.2. 802.11n HT20 MODE IN THE 5.2 GHz BAND

Channel	Frequency (MHz)	99% Bandwidth (MHz)
Low	5180	17.68
Mid	5200	17.66
High	5240	17.71
Worst		17.71

10.3.3. 802.11n HT40 MODE IN THE 5.2 GHz BAND

Channel	Frequency (MHz)	99% Bandwidth (MHz)
Low	5190	35.97
Mid	5230	36.05
Worst		36.05

10.3.1. 802.11a MODE IN THE 5.3 GHZ BAND

Channel	Frequency (MHz)	99% Bandwidth (MHz)
Low	5260	16.56
Mid	5300	16.47
High	5320	16.44
Worst		16.56

10.3.1. 802.11n HT20 MODE IN THE 5.3 GHZ BAND

Channel	Frequency (MHz)	99% Bandwidth (MHz)
Low	5260	17.63
Mid	5300	17.71
High	5320	17.64
Worst		17.71

10.3.2. 802.11n HT40 MODE IN THE 5.3 GHZ BAND

Channel	Frequency (MHz)	99% Bandwidth (MHz)
Low	5270	36.11
High	5310	36.05
Worst		36.11

10.3.3. 802.11a MODE IN THE 5.5 GHz BAND

Channel	Frequency (MHz)	99% Bandwidth (MHz)
Low	5500	16.51
Mid	5580	16.58
High	5700	16.45
Worst		16.58

10.3.4. 802.11n HT20 MODE IN THE 5.5 GHz BAND

Channel	Frequency (MHz)	99% Bandwidth (MHz)
Low	5500	17.76
Mid	5580	17.67
High	5700	17.69
Worst		17.76

10.3.5. 802.11n HT40 MODE IN THE 5.5 GHz BAND

Channel	Frequency (MHz)	99% Bandwidth (MHz)
Low	5510	36.19
Mid	5550	36.16
High	5670	36.23
Worst		36.23

10.3.6. 802.11a MODE IN THE 5.8 GHZ BAND

Channel	Frequency (MHz)	99% Bandwidth (MHz)
Low	5745	16.48
Mid	5785	16.47
High	5825	16.47
Worst		16.48

10.3.7. 802.11n HT20 MODE IN THE 5.8 GHZ BAND

Channel	Frequency (MHz)	99% Bandwidth (MHz)
Low	5745	17.70
Mid	5785	17.67
High	5825	17.69
Worst		17.70

10.3.8. 802.11n HT40 MODE IN THE 5.8 GHZ BAND

Channel	Frequency (MHz)	99% Bandwidth (MHz)
Low	5755	36.20
High	5795	36.17
Worst		36.20

10.3.1. 99% BANDWIDTH PLOTS

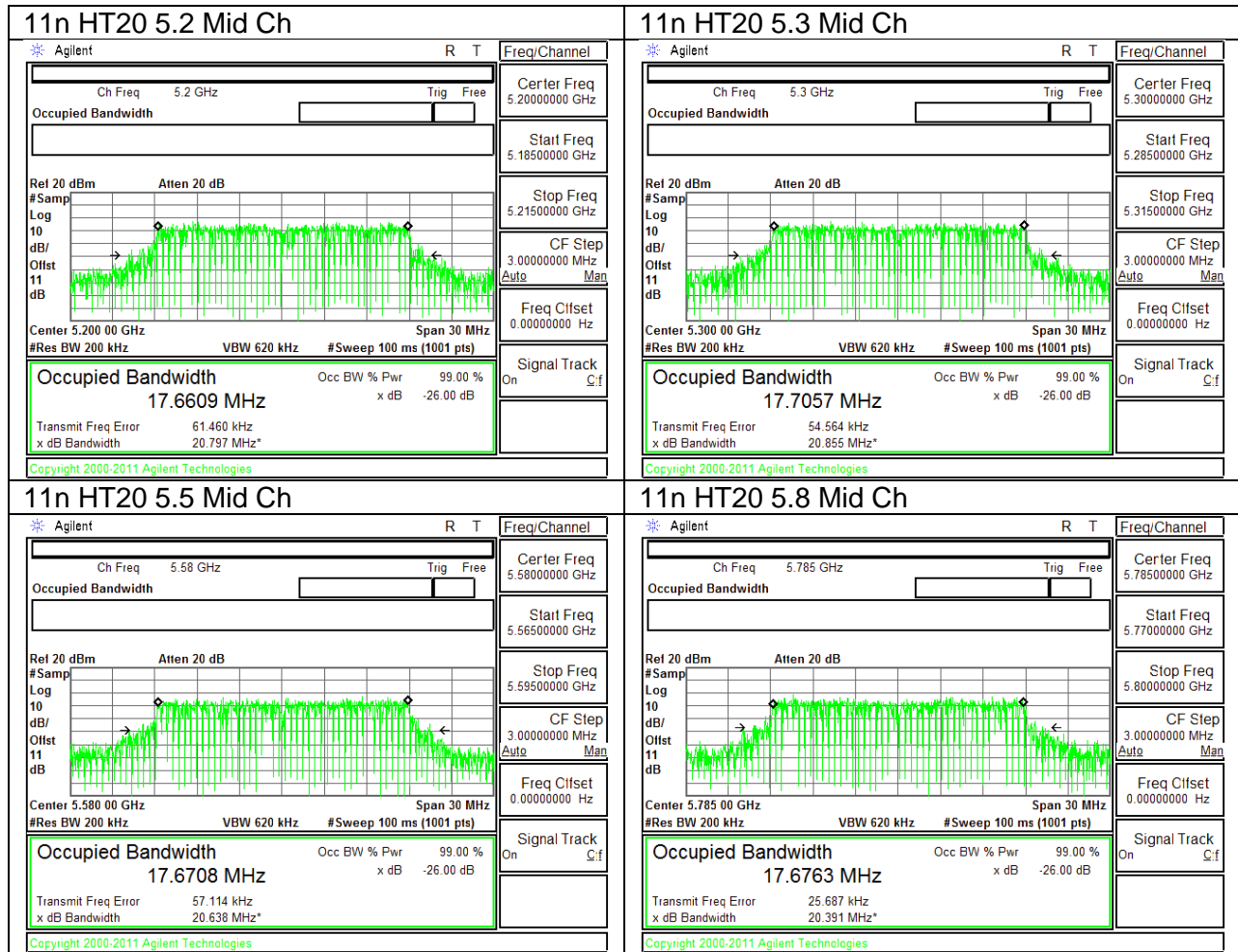

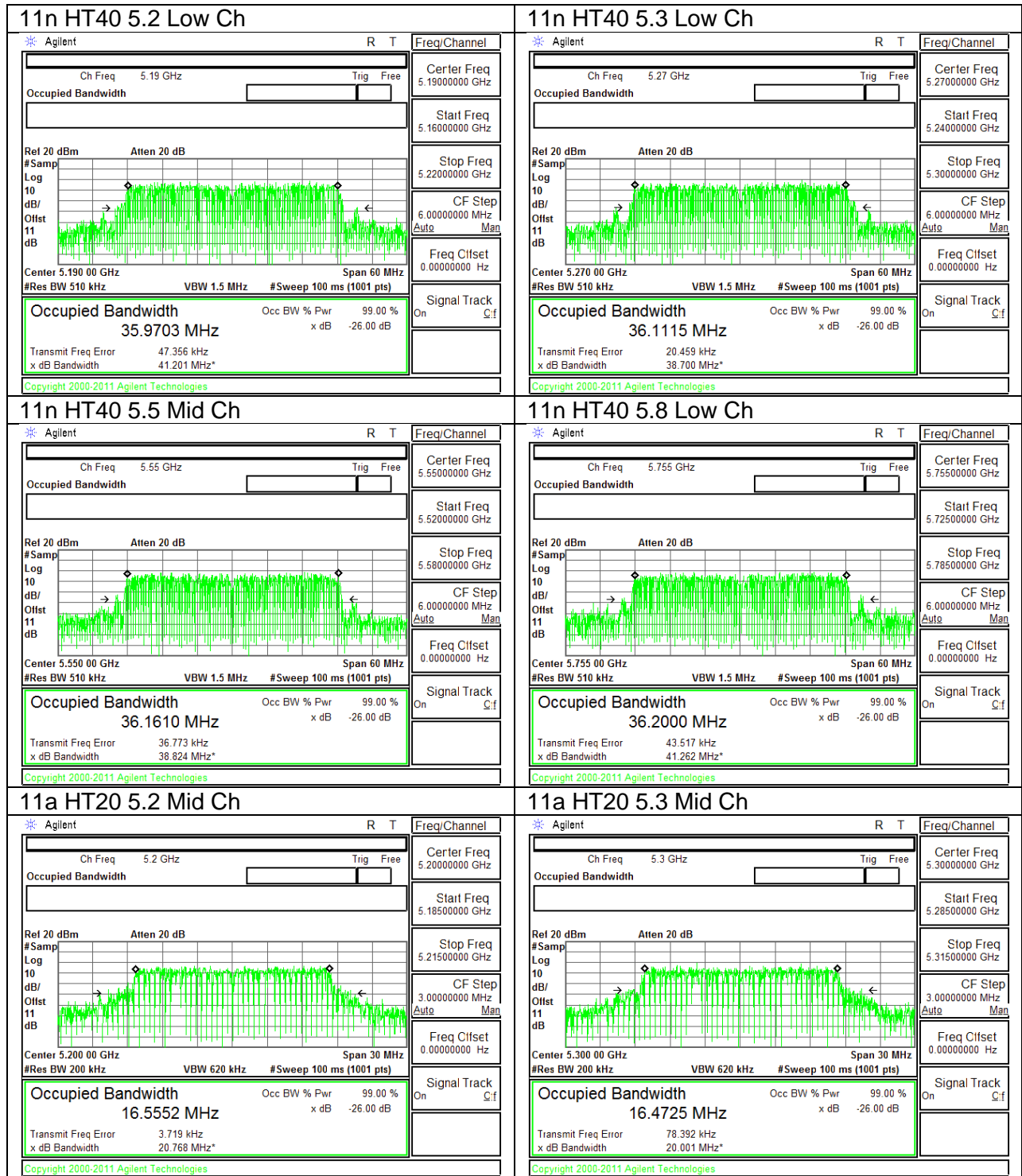

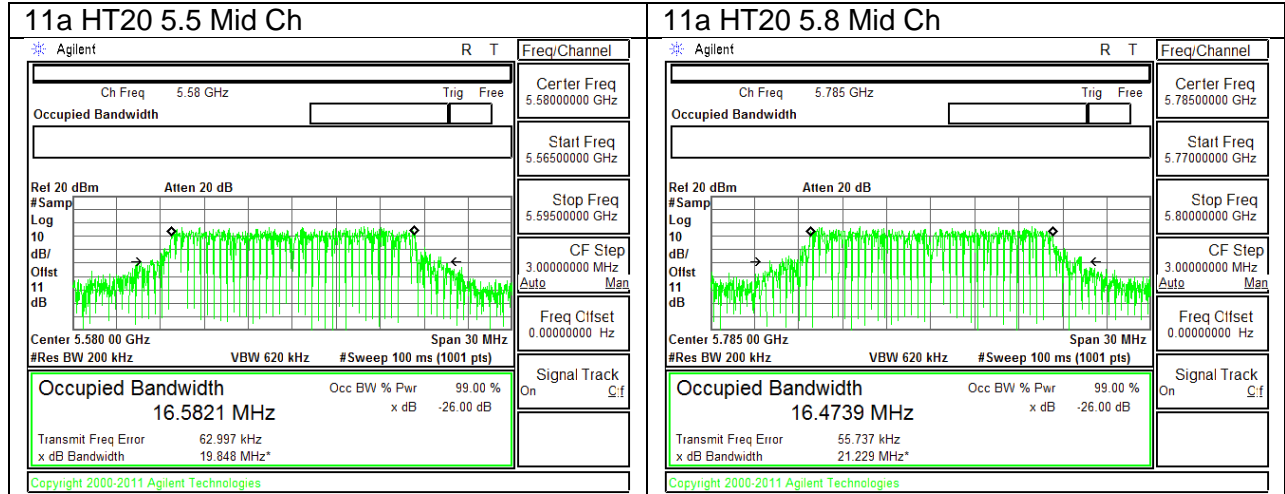

10.4. AVERAGE POWER

LIMITS

None; for reporting purposes only.

TEST PROCEDURE

The transmitter output is connected to a power meter.

The cable assembly insertion loss of 11 dB (including 10 dB pad and 1 dB cable) was entered as an offset in the power meter to allow for direct reading of power.

RESULTS

10.4.1. 802.11a MODE IN THE 5.2 GHZ BAND

Channel	Frequency (MHz)	Avg Power (dBm)
Low	5180	10.50
Mid	5200	10.20
High	5240	9.90
Worst		10.50

10.4.2. 802.11n HT20 MODE IN THE 5.2 GHZ BAND

Channel	Frequency (MHz)	Avg Power (dBm)
Low	5180	9.80
Mid	5200	10.30
High	5240	10.00
Worst		10.30

10.4.3. 802.11n HT40 MODE IN THE 5.2 GHZ BAND

Channel	Frequency (MHz)	Avg Power (dBm)
Low	5190	9.90
Mid	5230	10.10
Worst		10.10

10.4.4. 802.11a MODE IN THE 5.3 GHz BAND

Channel	Frequency (MHz)	Avg Power (dBm)
Low	5260	10.10
Mid	5300	10.30
High	5320	10.20
Worst		10.30

10.4.5. 802.11n HT20 MODE IN THE 5.3 GHz BAND

Channel	Frequency (MHz)	Avg Power (dBm)
Low	5260	10.00
Mid	5300	9.80
High	5320	10.20
Worst		10.20

10.4.6. 802.11n HT40 MODE IN THE 5.3 GHz BAND

Channel	Frequency (MHz)	Avg Power (dBm)
Low	5270	9.80
High	5310	9.90
Worst		9.90

10.4.7. 802.11a MODE IN THE 5.5 GHz BAND

Channel	Frequency (MHz)	Avg Power (dBm)
Low	5500	10.10
Mid	5580	9.90
High	5700	10.30
Worst		10.30

10.4.8. 802.11n HT20 MODE IN THE 5.5 GHz BAND

Channel	Frequency (MHz)	Avg Power (dBm)
Low	5500	9.90
Mid	5580	10.00
High	5700	9.80
Worst		10.00

10.4.9. 802.11n HT40 MODE IN THE 5.5 GHz BAND

Channel	Frequency (MHz)	Avg Power (dBm)
Low	5510	10.10
Mid	5550	10.00
High	5670	10.00
Worst		10.10

10.4.10. 802.11a MODE IN THE 5.8 GHz BAND

Channel	Frequency (MHz)	Avg Power (dBm)
Low	5745	10.10
Mid	5785	10.10
High	5825	9.80
Worst		10.10

10.4.11. 802.11n HT20 MODE IN THE 5.8 GHz BAND

Channel	Frequency (MHz)	Avg Power (dBm)
Low	5745	10.20
Mid	5785	10.20
High	5825	9.80
Worst		10.20

10.4.12. 802.11n HT40 MODE IN THE 5.8 GHz BAND

Channel	Frequency (MHz)	Avg Power (dBm)
Low	5755	9.70
High	5795	10.00
Worst		10.00

10.5. OUTPUT POWER AND PPSD

LIMITS

FCC §15.407 (a) (1)

For the band 5.15–5.25 GHz, the maximum conducted output power over the frequency band of operation shall not exceed the lesser of 250 mW or $11 \text{ dBm} + 10 \log B$, where B is the 26-dB emission bandwidth in MHz. In addition, the peak power spectral density shall not exceed 11 dBm in any 1-MHz band. If transmitting antennas of directional gain greater than 6 dBi are used, both the maximum conducted output power and the peak power spectral density shall be reduced by the amount in dB that the directional gain of the antenna exceeds 6 dBi.

IC RSS-210 A9.2 (1)

The maximum e.i.r.p. shall not exceed 200 mW or $10 + 10 \log_{10} B$, dBm, whichever power is less. B is the 99% emission bandwidth in MHz. The e.i.r.p. spectral density shall not exceed 10 dBm in any 1.0 MHz band.

DIRECTIONAL ANTENNA GAIN

There is only one transmitter output therefore the directional gain is equal to the antenna gain.

Test Methodology

RESULTS

10.5.1. 802.11a MODE IN THE 5.2 GHz BAND

Bandwidth and Antenna Gain

Channel	Frequency (MHz)	Min 26 dB BW (MHz)	Min 99% BW (MHz)	Directional Gain (dBi)
Low	5180	22.32	16.44	-0.50
Mid	5200	21.60	16.56	-0.50
High	5240	21.87	16.47	-0.50

Limits

Channel	Frequency (MHz)	FCC Power Limit (dBm)	IC EIRP Limit (dBm)	Max IC Power (dBm)	Power Limit (dBm)	FCC PPSD Limit (dBm)	IC eirp PSD Limit (dBm)	PPSD Limit (dBm)
Low	5180	24.00	22.16	22.66	22.66	11.00	10.00	10.50
Mid	5200	24.00	22.19	22.69	22.69	11.00	10.00	10.50
High	5240	24.00	22.17	22.67	22.67	11.00	10.00	10.50

Duty Cycle CF (dB)	0.32	Included in Calculations of Corr'd Power & PPSD
---------------------------	------	--

Output Power Results

Channel	Frequency (MHz)	Chain 0 Meas Power (dBm)	Total Corr'd Power (dBm)	Power Limit (dBm)	Power Margin (dB)
Low	5180	10.48	10.80	22.66	-11.86
Mid	5200	10.13	10.45	22.69	-12.24
High	5240	9.87	10.19	22.67	-12.48

PPSD Results

Channel	Frequency (MHz)	Chain 0 Meas PPSD (dBm)	Total Corr'd PPSD (dBm)	PPSD Limit (dBm)	PPSD Margin (dB)
Low	5180	-0.890	-0.57	10.50	-11.07
Mid	5200	-1.060	-0.74	10.50	-11.24
High	5240	-1.410	-1.09	10.50	-11.59

10.5.2. 802.11n HT20 MODE IN THE 5.2 GHz BAND

Bandwidth and Antenna Gain

Channel	Frequency (MHz)	Min 26 dB BW (MHz)	Min 99% BW (MHz)	Directional Gain (dBi)
Low	5180	21.99	17.68	-0.50
Mid	5200	22.41	17.66	-0.50
High	5240	22.08	17.71	-0.50

Limits

Channel	Frequency (MHz)	FCC Power Limit (dBm)	IC EIRP Limit (dBm)	Max IC Power (dBm)	Power Limit (dBm)	FCC PPSD Limit (dBm)	IC eirp PSD Limit (dBm)	PPSD Limit (dBm)
Low	5180	24.00	22.47	22.97	22.97	11.00	10.00	10.50
Mid	5200	24.00	22.47	22.97	22.97	11.00	10.00	10.50
High	5240	24.00	22.48	22.98	22.98	11.00	10.00	10.50

Duty Cycle CF (dB)	0.33	Included in Calculations of Corr'd Power & PPSD
---------------------------	------	--

Output Power Results

Channel	Frequency (MHz)	Chain 0 Meas Power (dBm)	Total Corr'd Power (dBm)	Power Limit (dBm)	Power Margin (dB)
Low	5180	9.430	9.76	22.97	-13.21
Mid	5200	10.110	10.44	22.97	-12.53
High	5240	9.790	10.12	22.98	-12.86

PPSD Results

Channel	Frequency (MHz)	Chain 0 Meas PPSD (dBm)	Total Corr'd PPSD (dBm)	PPSD Limit (dBm)	PPSD Margin (dB)
Low	5180	-2.130	-1.80	10.50	-12.30
Mid	5200	-1.280	-0.95	10.50	-11.45
High	5240	-1.720	-1.39	10.50	-11.89

10.5.3. 802.11n HT40 MODE IN THE 5.2 GHz BAND

Bandwidth and Antenna Gain

Channel	Frequency (MHz)	Min 26 dB BW (MHz)	Min 99% BW (MHz)	Directional Gain (dBi)
Low	5190	43.920	35.970	-0.50
Mid	5230	44.880	36.050	-0.50

Limits

Channel	Frequency (MHz)	FCC Power Limit (dBm)	IC EIRP Limit (dBm)	Max IC Power (dBm)	Power Limit (dBm)	FCC PPSD Limit (dBm)	IC eirp PSD Limit (dBm)	PPSD Limit (dBm)
Low	5190	24.00	23.00	23.50	23.50	11.00	10.00	10.50
Mid	5230	24.00	23.00	23.50	23.50	11.00	10.00	10.50
Duty Cycle CF (dB)		0.64	Included in Calculations of Corr'd Power & PPSD					

Output Power Results

Channel	Frequency (MHz)	Chain 0 Meas Power (dBm)	Total Corr'd Power (dBm)	Power Limit (dBm)	Power Margin (dB)
Low	5190	9.330	9.97	23.50	-13.53
Mid	5230	9.600	10.24	23.50	-13.26

PPSD Results

Channel	Frequency (MHz)	Chain 0 Meas PPSD (dBm)	Total Corr'd PPSD (dBm)	PPSD Limit (dBm)	PPSD Margin (dB)
Low	5190	-4.970	-4.33	10.50	-14.83
Mid	5230	-4.640	-4.00	10.50	-14.50

802.11a MODE IN THE 5.3 GHz BAND

Bandwidth and Antenna Gain

Channel	Frequency (MHz)	Min 26 dB BW (MHz)	Min 99% BW (MHz)	Directional Gain (dBi)
Low	5260	22.14	16.56	-0.50
Mid	5300	22.29	16.47	-0.50
High	5320	22.17	16.44	-0.50

Limits

Channel	Frequency (MHz)	FCC Power Limit (dBm)	IC Power Limit (dBm)	IC EIRP Limit (dBm)	Power Limit (dBm)	FCC PPSD Limit (dBm)	IC PSD Limit (dBm)	PPSD Limit (dBm)
Low	5260	24.00	23.19	29.19	23.19	11.00	11.00	11.00
Mid	5300	24.00	23.17	29.17	23.17	11.00	11.00	11.00
High	5320	24.00	23.16	29.16	23.16	11.00	11.00	11.00

Duty Cycle CF (dB)	0.32	Included in Calculations of Corr'd Power & PPSD
---------------------------	------	--

Output Power Results

Channel	Frequency (MHz)	Chain 0 Meas Power (dBm)	Total Corr'd Power (dBm)	Power Limit (dBm)	Power Margin (dB)
Low	5260	10.050	10.37	24.00	-13.63
Mid	5300	10.020	10.34	24.00	-13.66
High	5320	10.430	10.75	24.00	-13.25

PPSD Results

Channel	Frequency (MHz)	Chain 0 Meas PPSD (dBm)	Total Corr'd PPSD (dBm)	PPSD Limit (dBm)	PPSD Margin (dB)
Low	5260	-1.090	-0.77	11.00	-11.77
Mid	5300	-1.120	-0.80	11.00	-11.80
High	5320	-0.890	-0.57	11.00	-11.57

10.5.4. 802.11n HT20 MODE IN THE 5.3 GHz BAND

Bandwidth and Antenna Gain

Channel	Frequency (MHz)	Min 26 dB BW (MHz)	Min 99% BW (MHz)	Directional Gain (dBi)
Low	5260	22.05	17.63	-0.50
Mid	5300	22.68	17.70	-0.50
High	5320	21.99	17.64	-0.50

Limits

Channel	Frequency (MHz)	FCC Power Limit (dBm)	IC Power Limit (dBm)	IC EIRP Limit (dBm)	Power Limit (dBm)	FCC PPSD Limit (dBm)	IC PSD Limit (dBm)	PPSD Limit (dBm)
Low	5260	24.00	23.46	29.46	23.46	11.00	11.00	11.00
Mid	5300	24.00	23.48	29.48	23.48	11.00	11.00	11.00
High	5320	24.00	23.46	29.46	23.46	11.00	11.00	11.00

Duty Cycle CF (dB)	0.33	Included in Calculations of Corr'd Power & PPSD
---------------------------	------	--

Output Power Results

Channel	Frequency (MHz)	Chain 0 Meas Power (dBm)	Total Corr'd Power (dBm)	Power Limit (dBm)	Power Margin (dB)
Low	5260	10.070	10.40	24.00	-13.60
Mid	5300	9.770	10.10	24.00	-13.90
High	5320	10.430	10.76	24.00	-13.24

PPSD Results

Channel	Frequency (MHz)	Chain 0 Meas PPSD (dBm)	Total Corr'd PPSD (dBm)	PPSD Limit (dBm)	PPSD Margin (dB)
Low	5260	-1.360	-1.03	11.00	-12.03
Mid	5300	-1.680	-1.35	11.00	-12.35
High	5320	-1.000	-0.67	11.00	-11.67

10.5.5. 802.11n HT40 MODE IN THE 5.3 GHz BAND

Bandwidth and Antenna Gain

Channel	Frequency (MHz)	Min 26 dB BW (MHz)	Min 99% BW (MHz)	Directional Gain (dBi)
Low	5270	43.2	36.1	-0.50
High	5310	44.1	36.1	-0.50

Limits

Channel	Frequency (MHz)	FCC Power Limit (dBm)	IC Power Limit (dBm)	IC EIRP Limit (dBm)	Power Limit (dBm)	FCC PPSD Limit (dBm)	IC PSD Limit (dBm)	PPSD Limit (dBm)
Low	5270	24.00	24.00	30.00	24.00	11.00	11.00	11.00
High	5310	24.00	24.00	30.00	24.00	11.00	11.00	11.00

Duty Cycle CF (dB)	0.64	Included in Calculations of Corr'd Power & PSD
---------------------------	------	---

Output Power Results

Channel	Frequency (MHz)	Chain 0 Meas Power (dBm)	Total Corr'd Power (dBm)	Power Limit (dBm)	Power Margin (dB)
Low	5270	9.3	9.98	24.00	-14.02
High	5310	9.6	10.20	24.00	-13.80

PPSD Results

Channel	Frequency (MHz)	Chain 0 Meas PPSD (dBm)	Total Corr'd PPSD (dBm)	PPSD Limit (dBm)	PPSD Margin (dB)
Low	5270	-4.89	-4.25	11.00	-15.25
High	5310	-4.70	-4.06	11.00	-15.06

802.11a MODE IN THE 5.5 GHz BAND

Bandwidth and Antenna Gain

Channel	Frequency (MHz)	Min 26 dB BW (MHz)	Min 99% BW (MHz)	Directional Gain (dBi)
Low	5500	22.980	16.510	-0.50
Mid	5580	22.170	16.580	-0.50
High	5700	21.780	16.450	-0.50

Limits

Channel	Frequency (MHz)	FCC Power Limit (dBm)	IC Power Limit (dBm)	IC EIRP Limit (dBm)	Power Limit (dBm)	FCC PPSD Limit (dBm)	IC PSD Limit (dBm)	PPSD Limit (dBm)
Low	5500	24.00	24.00	29.18	24.00	11.00	11.00	11.00
Mid	5580	24.00	24.00	29.20	24.00	11.00	11.00	11.00
High	5700	24.00	24.00	29.16	24.00	11.00	11.00	11.00

Duty Cycle CF (dB)	0.32	Included in Calculations of Corr'd Power & PPSD
---------------------------	------	--

Output Power Results

Channel	Frequency (MHz)	Chain 0 Meas Power (dBm)	Total Corr'd Power (dBm)	Power Limit (dBm)	Power Margin (dB)
Low	5500	10.030	10.35	24.00	-13.65
Mid	5580	9.770	10.09	24.00	-13.91
High	5700	10.270	10.59	24.00	-13.41

PPSD Results

Channel	Frequency (MHz)	Chain 0 Meas PPSD (dBm)	Total Corr'd PPSD (dBm)	PPSD Limit (dBm)	PPSD Margin (dB)
Low	5500	-1.120	-0.80	11.00	-11.80
Mid	5580	-1.530	-1.21	11.00	-12.21
High	5700	-0.960	-0.64	11.00	-11.64

10.5.6. 802.11n HT20 MODE IN THE 5.5 GHz BAND

Bandwidth and Antenna Gain

Channel	Frequency (MHz)	Min 26 dB BW (MHz)	Min 99% BW (MHz)	Directional Gain (dBi)
Low	5500	22.200	17.760	-0.50
Mid	5580	22.320	17.670	-0.50
High	5700	22.500	17.690	-0.50

Limits

Channel	Frequency (MHz)	FCC Power Limit (dBm)	IC Power Limit (dBm)	IC EIRP Limit (dBm)	Power Limit (dBm)	FCC PPSD Limit (dBm)	IC PSD Limit (dBm)	PPSD Limit (dBm)
Low	5500	24.00	24.00	29.49	24.00	11.00	11.00	11.00
Mid	5580	24.00	24.00	29.47	24.00	11.00	11.00	11.00
High	5700	24.00	24.00	29.48	24.00	11.00	11.00	11.00

Duty Cycle CF (dB)	0.33	Included in Calculations of Corr'd Power & PPSD
---------------------------	------	--

Output Power Results

Channel	Frequency (MHz)	Chain 0 Meas Power (dBm)	Total Corr'd Power (dBm)	Power Limit (dBm)	Power Margin (dB)
Low	5500	9.820	10.15	24.00	-13.85
Mid	5580	9.650	9.98	24.00	-14.02
High	5700	9.510	9.84	24.00	-14.16

PPSD Results

Channel	Frequency (MHz)	Chain 0 Meas PPSD (dBm)	Total Corr'd PPSD (dBm)	PPSD Limit (dBm)	PPSD Margin (dB)
Low	5500	-1.670	-1.34	11.00	-12.34
Mid	5580	-1.860	-1.53	11.00	-12.53
High	5700	-1.660	-1.33	11.00	-12.33

10.5.7. 802.11n HT40 MODE IN THE 5.5 GHz BAND

Bandwidth and Antenna Gain

Channel	Frequency (MHz)	Min 26 dB BW (MHz)	Min 99% BW (MHz)	Directional Gain (dBi)
Low	5510	44.0	36.2	-0.50
Mid	5550	44.2	36.2	-0.50
High	5670	44.3	36.2	-0.50

Limits

Channel	Frequency (MHz)	FCC Power Limit (dBm)	IC Power Limit (dBm)	IC EIRP Limit (dBm)	Power Limit (dBm)	FCC PPSD Limit (dBm)	IC PSD Limit (dBm)	PPSD Limit (dBm)
Low	5510	24.00	24.00	30.00	24.00	11.00	11.00	11.00
Mid	5550	24.00	24.00	30.00	24.00	11.00	11.00	11.00
High	5670	24.00	24.00	30.00	24.00	11.00	11.00	11.00

Duty Cycle CF (dB)	0.64	Included in Calculations of Corr'd Power & PPSD
---------------------------	------	--

Output Power Results

Channel	Frequency (MHz)	Chain 0 Meas Power (dBm)	Total Corr'd Power (dBm)	Power Limit (dBm)	Power Margin (dB)
Low	5510	10.160	10.80	24.00	-13.20
Mid	5550	9.880	10.52	24.00	-13.48
High	5670	9.880	10.52	24.00	-13.48

PPSD Results

Channel	Frequency (MHz)	Chain 0 Meas PPSD (dBm)	Total Corr'd PPSD (dBm)	PPSD Limit (dBm)	PPSD Margin (dB)
Low	5510	-4.210	-3.57	11.00	-14.57
Mid	5550	-4.460	-3.82	11.00	-14.82
High	5670	-4.430	-3.79	11.00	-14.79

802.11a MODE IN THE 5.8 GHz BAND

Bandwidth and Antenna Gain

Channel	Frequency (MHz)	Min 26 dB BW (MHz)	Min 99% BW (MHz)	Directional Gain (dBi)
Low	5745	22.290	16.480	-0.50
Mid	5785	22.080	16.470	-0.50
High	5825	22.230	16.470	-0.50

Limits

Channel	Frequency (MHz)	FCC Power Limit (dBm)	IC Power Limit (dBm)	IC EIRP Limit (dBm)	Power Limit (dBm)	FCC PPSD Limit (dBm)	IC PSD Limit (dBm)	PPSD Limit (dBm)
Low	5745	30.00	30.00	35.17	30.00	17.00	17.00	17.00
Mid	5785	30.00	30.00	35.17	30.00	17.00	17.00	17.00
High	5825	30.00	30.00	35.17	30.00	17.00	17.00	17.00

Duty Cycle CF (dB)	0.32	Included in Calculations of Corr'd Power & PPSD
---------------------------	------	--

Output Power Results

Channel	Frequency (MHz)	Chain 0 Meas Power (dBm)	Total Corr'd Power (dBm)	Power Limit (dBm)	Power Margin (dB)
Low	5745	10.06	10.38	30.00	-19.62
Mid	5785	10.19	10.51	30.00	-19.49
High	5825	9.63	9.95	30.00	-20.05

PPSD Results

Channel	Frequency (MHz)	Chain 0 Meas PPSD (dBm)	Total Corr'd PPSD (dBm)	PPSD Limit (dBm)	PPSD Margin (dB)
Low	5745	-3.37	-3.05	17.00	-20.05
Mid	5785	-3.68	-3.36	17.00	-20.36
High	5825	-4.22	-3.90	17.00	-20.90

10.5.8. 802.11n HT20 MODE IN THE 5.8 GHz BAND

Bandwidth and Antenna Gain

Channel	Frequency (MHz)	Min 26 dB BW (MHz)	Min 99% BW (MHz)	Directional Gain (dBi)
Low	5745	21.990	17.700	-0.50
Mid	5785	22.320	17.680	-0.50
High	5825	22.470	17.690	-0.50

Limits

Channel	Frequency (MHz)	FCC Power Limit (dBm)	IC Power Limit (dBm)	IC EIRP Limit (dBm)	Power Limit (dBm)	FCC PPSD Limit (dBm)	IC PSD Limit (dBm)	PPSD Limit (dBm)
Low	5745	30.00	30.00	35.48	30.00	17.00	17.00	17.00
Mid	5785	30.00	30.00	35.47	30.00	17.00	17.00	17.00
High	5825	30.00	30.00	35.48	30.00	17.00	17.00	17.00

Duty Cycle CF (dB)	0.33	Included in Calculations of Corr'd Power & PPSD
---------------------------	------	--

Output Power Results

Channel	Frequency (MHz)	Chain 0 Meas Power (dBm)	Total Corr'd Power (dBm)	Power Limit (dBm)	Power Margin (dB)
Low	5745	10.18	10.51	30.00	-19.49
Mid	5785	10.18	10.51	30.00	-19.49
High	5825	9.61	9.94	30.00	-20.06

PPSD Results

Channel	Frequency (MHz)	Chain 0 Meas PPSD (dBm)	Total Corr'd PPSD (dBm)	PPSD Limit (dBm)	PPSD Margin (dB)
Low	5745	-3.93	-3.60	17.00	-20.60
Mid	5785	-3.52	-3.19	17.00	-20.19
High	5825	-4.61	-4.28	17.00	-21.28

10.5.9. 802.11n HT40 MODE IN THE 5.8 GHz BAND

Bandwidth and Antenna Gain

Channel	Frequency (MHz)	Min 26 dB BW (MHz)	Min 99% BW (MHz)	Directional Gain (dBi)
Low	5755	44.2	36.2	-0.50
High	5795	43.6	36.2	-0.50

Limits

Channel	Frequency (MHz)	FCC Power Limit (dBm)	IC Power Limit (dBm)	IC EIRP Limit (dBm)	Power Limit (dBm)	FCC PPSD Limit (dBm)	IC PSD Limit (dBm)	PPSD Limit (dBm)
Low	5755	30.00	30.00	36.00	30.00	17.00	17.00	17.00
High	5795	30.00	30.00	36.00	30.00	17.00	17.00	17.00

Duty Cycle CF (dB)	0.64	Included in Calculations of Corr'd Power & PPSD
---------------------------	------	--

Output Power Results

Channel	Frequency (MHz)	Chain 0 Meas Power (dBm)	Total Corr'd Power (dBm)	Power Limit (dBm)	Power Margin (dB)
Low	5755	9.33	9.97	30.00	-20.03
High	5795	9.83	10.47	30.00	-19.53

PPSD Results

Channel	Frequency (MHz)	Chain 0 Meas PPSD (dBm)	Total Corr'd PPSD (dBm)	PPSD Limit (dBm)	PPSD Margin (dB)
Low	5755	-7.51	-6.87	17.00	-23.87
High	5795	-7.12	-6.48	17.00	-23.48

10.5.10. OUTPUT POWER AND PPSD PLOTS, Chain 0

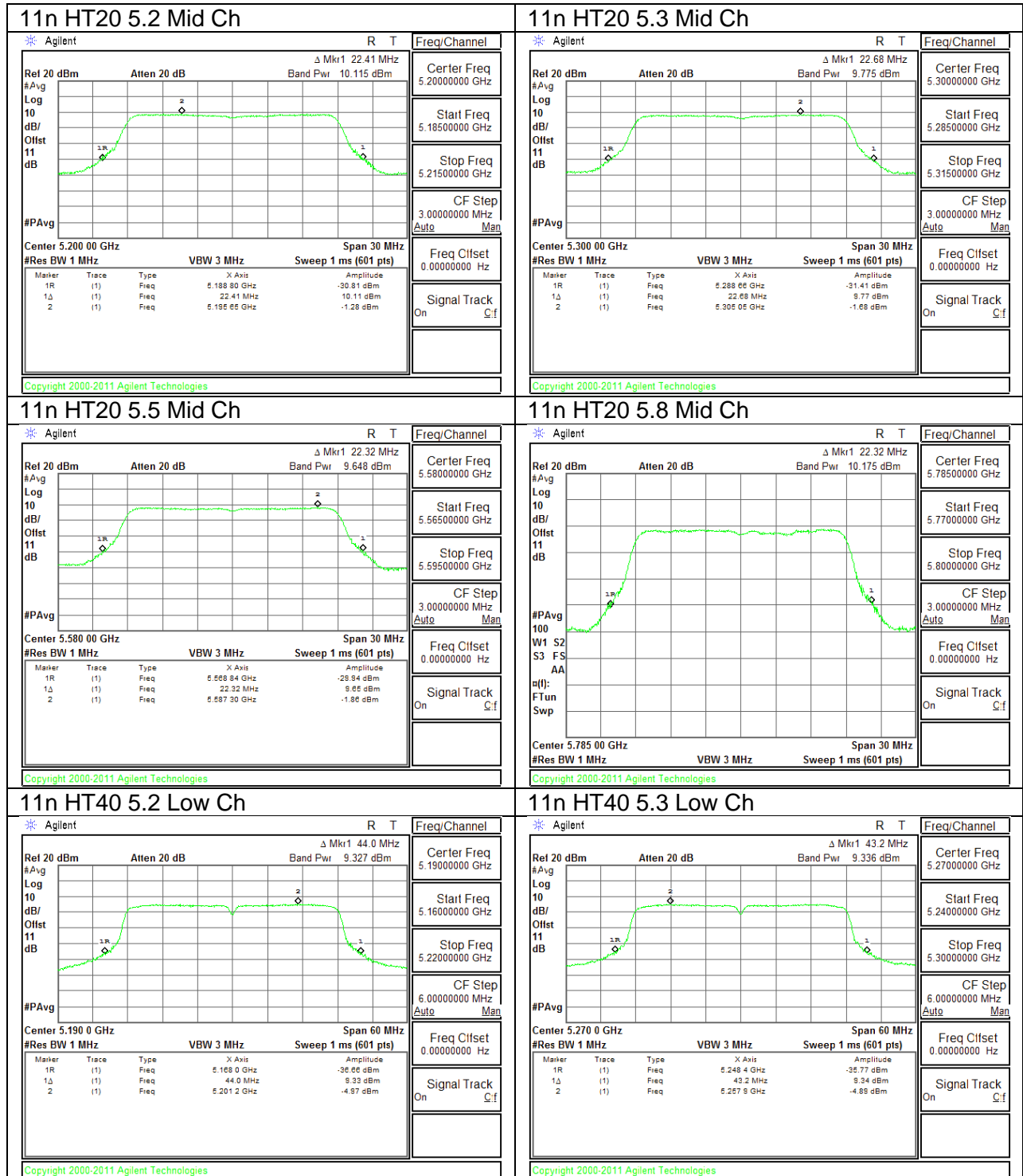

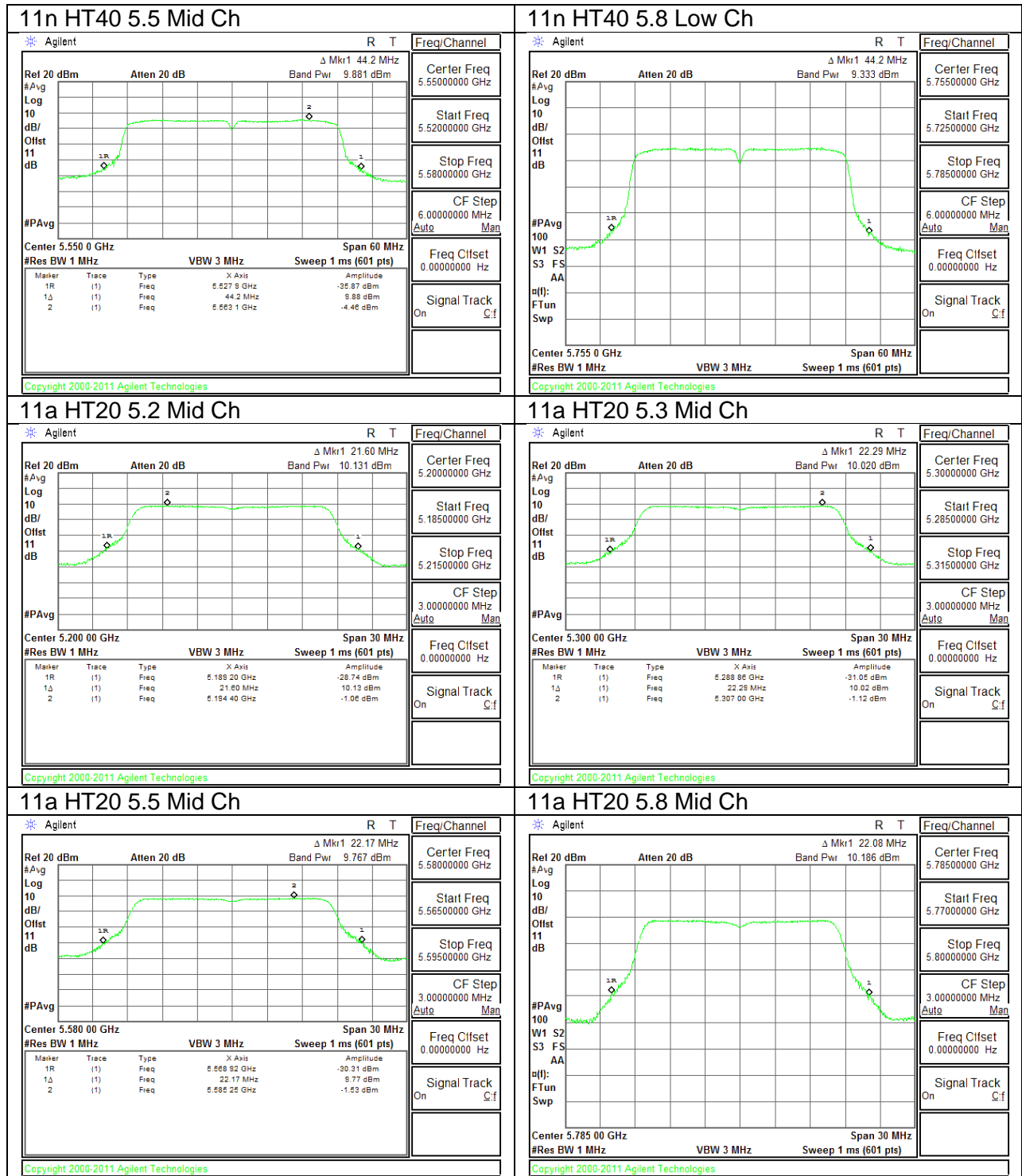

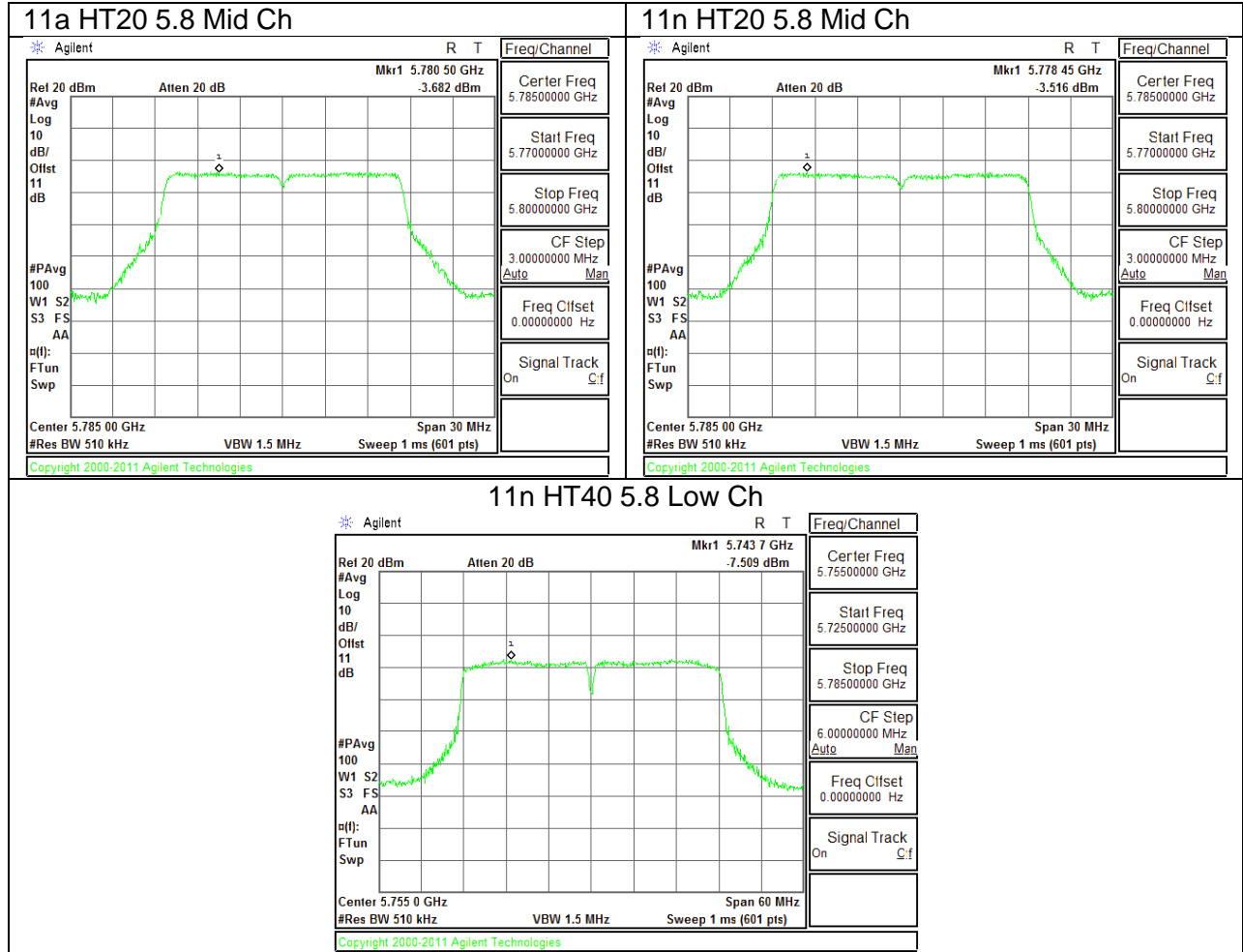

11. TRANSMITTER ABOVE 1 GHz

LIMITS

FCC §15.205 and §15.209

Frequency Range (MHz)	Field Strength Limit (uV/m) at 3 m	Field Strength Limit (dBuV/m) at 3 m
30 - 88	100	40
88 - 216	150	43.5
216 - 960	200	46
Above 960	500	54

TEST PROCEDURE

The EUT is placed on a non-conducting table 80 cm above the ground plane. The antenna to EUT distance is 3 meters.

For measurements below 1 GHz the resolution bandwidth is set to 100 kHz for peak detection measurements or 120 kHz for quasi-peak detection measurements. Peak detection is used unless otherwise noted as quasi-peak.

Reference to KDB 789033 UNII part G) 6) c) Method AD:

For measurements above 1 GHz the resolution bandwidth is set to 1 MHz; the video bandwidth is set to 3 MHz for peak measurements and add duty cycle factor to the reading offset for average measurements.

The spectrum from 1GHz to 40 GHz is investigated with the transmitter set to the lowest, middle, and highest channels in each applicable band.

The frequency range of interest is monitored at a fixed antenna height and EUT azimuth. The EUT is rotated through 360 degrees to maximize emissions received. The antenna is scanned from 1 to 4 meters above the ground plane to further maximize the emission. Measurements are made with the antenna polarized in both the vertical and the horizontal positions.

11.1. 5.2 GHz

11.1.1. TX ABOVE 1 GHz 802.11a MODE IN THE 5.2 GHz BAND

RESTRICTED BANDEDGE (LOW CHANNEL)

HORIZONTAL PEAK AND AVERAGE PLOT

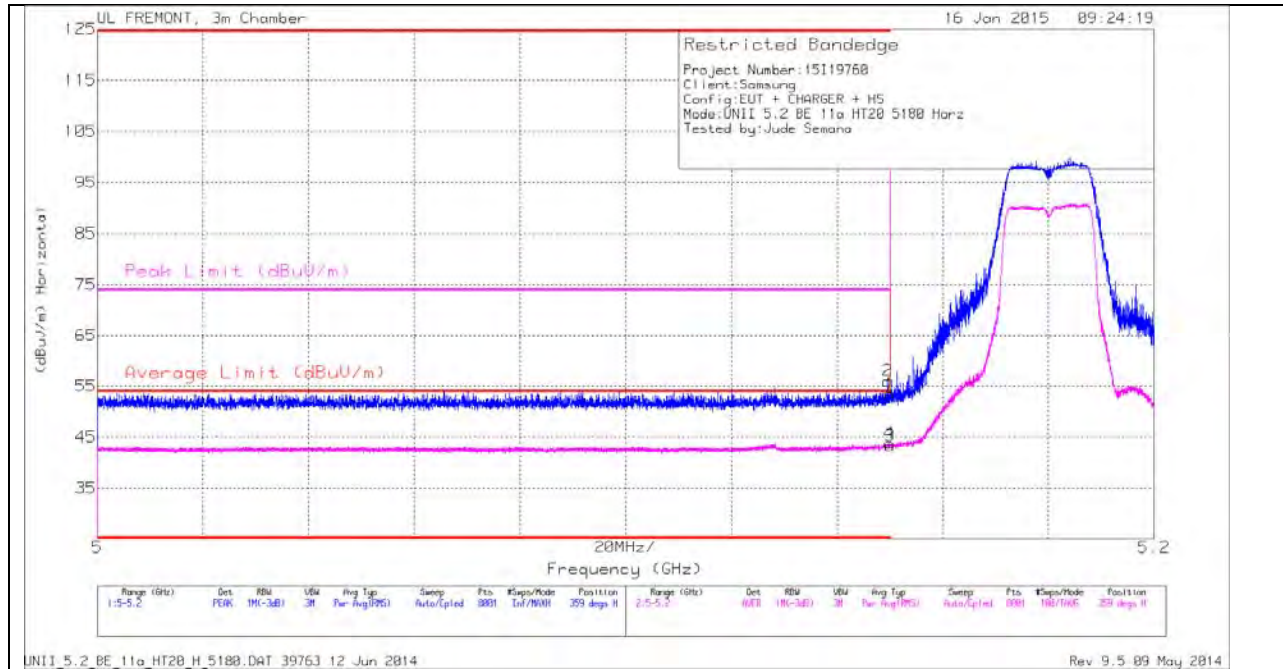

HORIZONTAL DATA

Marker	Frequency (GHz)	Meter Reading (dBuV)	Det	AF T711 (dB/m)	Amp/Cb/Filter/Pad (dB)	DC Corr (dB)	Corrected Reading (dBuV/m)	Average Limit (dBuV/m)	Margin (dB)	Peak Limit (dBuV/m)	PK Margin (dB)	Azimuth (Degs)	Height (cm)	Polarity
1	* 5.15	40.96	PK	34.2	-21.6	0	53.56	-	-	74	-20.44	359	304	H
2	* 5.15	43.38	PK	34.2	-21.6	0	55.98	-	-	74	-18.02	359	304	H
3	* 5.15	30.42	RMS	34.2	-21.6	.32	43.32	54	-10.68	-	-	359	304	H
4	* 5.15	30.86	RMS	34.2	-21.6	.32	43.76	54	-10.24	-	-	359	304	H

VERTICAL PEAK AND AVERAGE PLOT

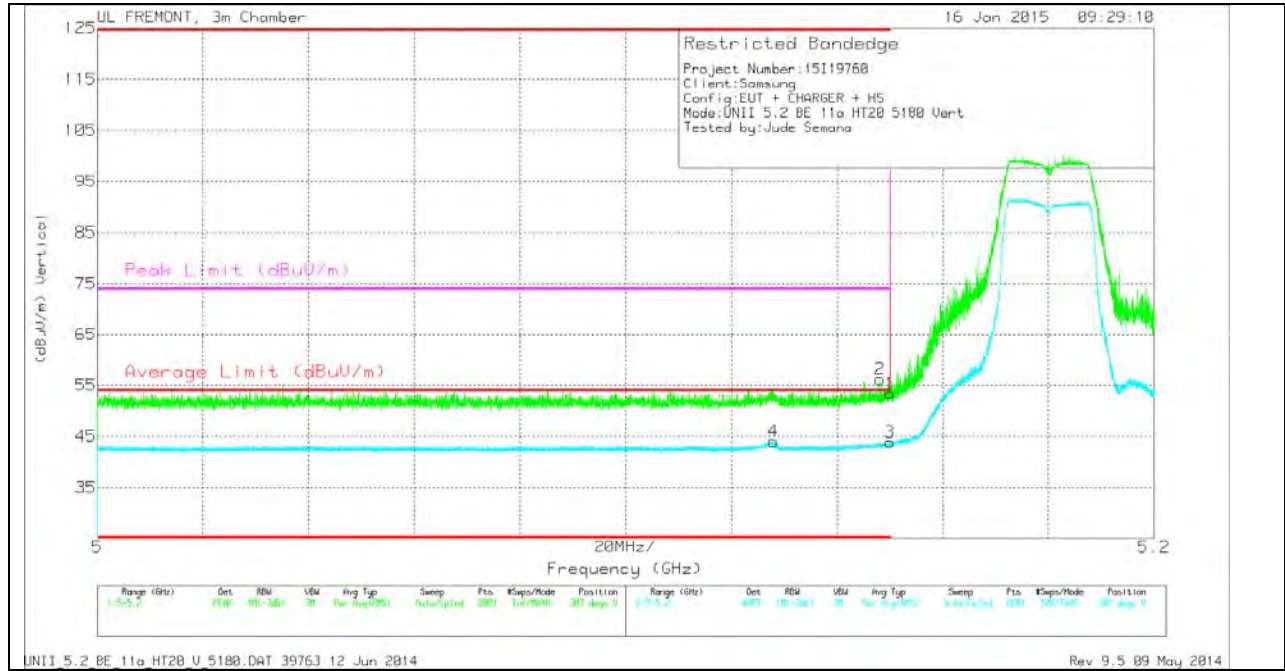

VERTICAL DATA

Marker	Frequency (GHz)	Meter Reading (dBuV)	Det	AF T711 (dB/m)	Amp/Cb/Fit r/Pad (dB)	DC Corr (dB)	Corrected Reading (dBuV/m)	Average Limit (dBuV/m)	Margin (dB)	Peak Limit (dBuV/m)	PK Margin (dB)	Azimuth (Degs)	Height (cm)	Polarity
1	* 5.15	40.82	PK	34.2	-21.6	0	53.42	-	-	74	-20.58	307	278	V
2	* 5.148	43.58	PK	34.2	-21.6	0	56.18	-	-	74	-17.82	307	278	V
3	* 5.15	30.92	RMS	34.2	-21.6	.32	43.82	54	-10.18	-	-	307	278	V
4	* 5.128	31.06	RMS	34.2	-21.5	.32	44.06	54	-9.94	-	-	307	278	V

HARMONICS AND SPURIOUS EMISSIONS

LOW CHANNEL HORIZONTAL

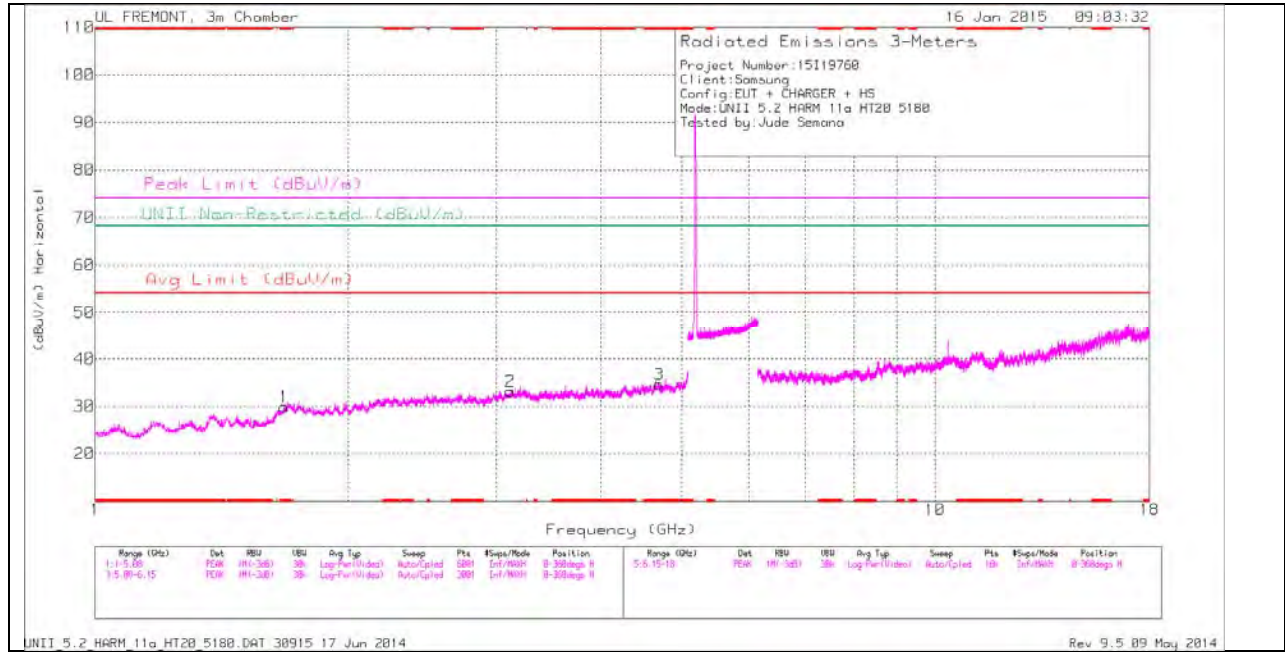

Note: Emission was scanned up to 40GHz; No emissions were detected above the noise floor which was at least 20dB below the specification limit.

LOW CHANNEL VERTICAL

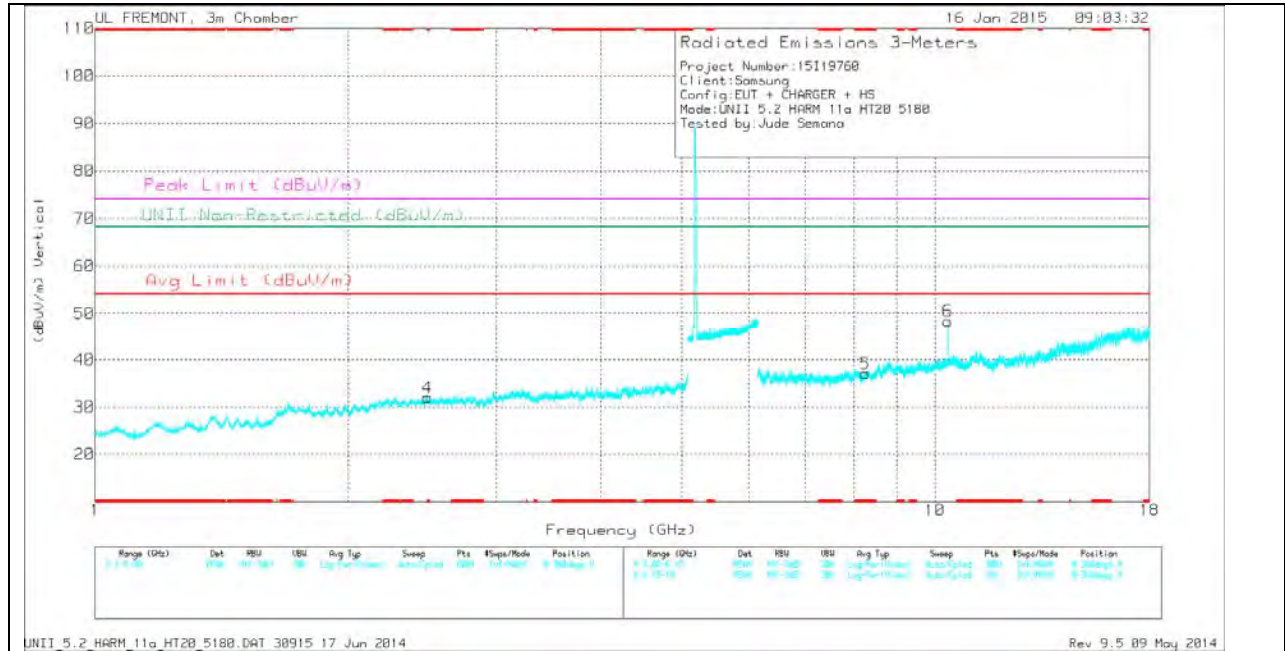

Note: Emission was scanned up to 40GHz; No emissions were detected above the noise floor which was at least 20dB below the specification limit.

LOW CHANNEL DATA

TRACE MARKERS

Marker	Frequency (GHz)	Meter Reading (dBuV)	Det	AF T711 (dB/m)	Amp/Cbl/Ftr/Pad (dB)	DC Corr (dB)	Corrected Reading (dBuV/m)	Avg Limit (dBuV/m)	Margin (dB)	Peak Limit (dBuV/m)	PK Margin (dB)	UNII Non-Restricted (dBuV/m)	PK Margin (dB)	Azimuth (Degs)	Height (cm)	Polarity
1	* 1.68	32.31	PK	30.1	-32.5	0	29.91	-	-	74	-44.09	-	-	0-360	100	H
3	* 4.692	31.23	PK	33.9	-30.5	0	34.63	-	-	74	-39.37	-	-	0-360	200	H
4	* 2.486	32.17	PK	32.1	-32.2	0	32.07	-	-	74	-41.93	-	-	0-360	200	V
5	* 8.26	28.96	PK	36.1	-28	0	37.06	-	-	74	-36.94	-	-	0-360	100	V
2	3.122	32.16	PK	33	-32	0	33.16	-	-	-	-	68.2	-35.04	0-360	200	H
6	10.36	35.77	PK	38	-25.4	0	48.37	-	-	-	-	68.2	-19.83	0-360	200	V

* - indicates frequency in CFR15.205/IC7.2.2 Restricted Band

PK - Peak detector

Radiated Emissions

Frequency (GHz)	Meter Reading (dBuV)	Det	AF T711 (dB/m)	Amp/Cbl/Ftr/Pad (dB)	DC Corr (dB)	Corrected Reading (dBuV/m)	Avg Limit (dBuV/m)	Margin (dB)	Peak Limit (dBuV/m)	PK Margin (dB)	UNII Non-Restricted (dBuV/m)	PK Margin (dB)	Azimuth (Degs)	Height (cm)	Polarity
10.36	40.79	PK1	38	-25.4	0	53.39	-	-	-	-	68.2	-14.81	3	365	V
10.36	35.29	AD1	38	-25.4	.32	48.19	-	-	-	-	-	-	3	365	V

* - indicates frequency in CFR15.205/IC7.2.2 Restricted Band

PK1 - KDB789033 Method: Peak

AD1 - KDB789033 Method: AD Primary Power Average

MID CHANNEL HORIZONTAL

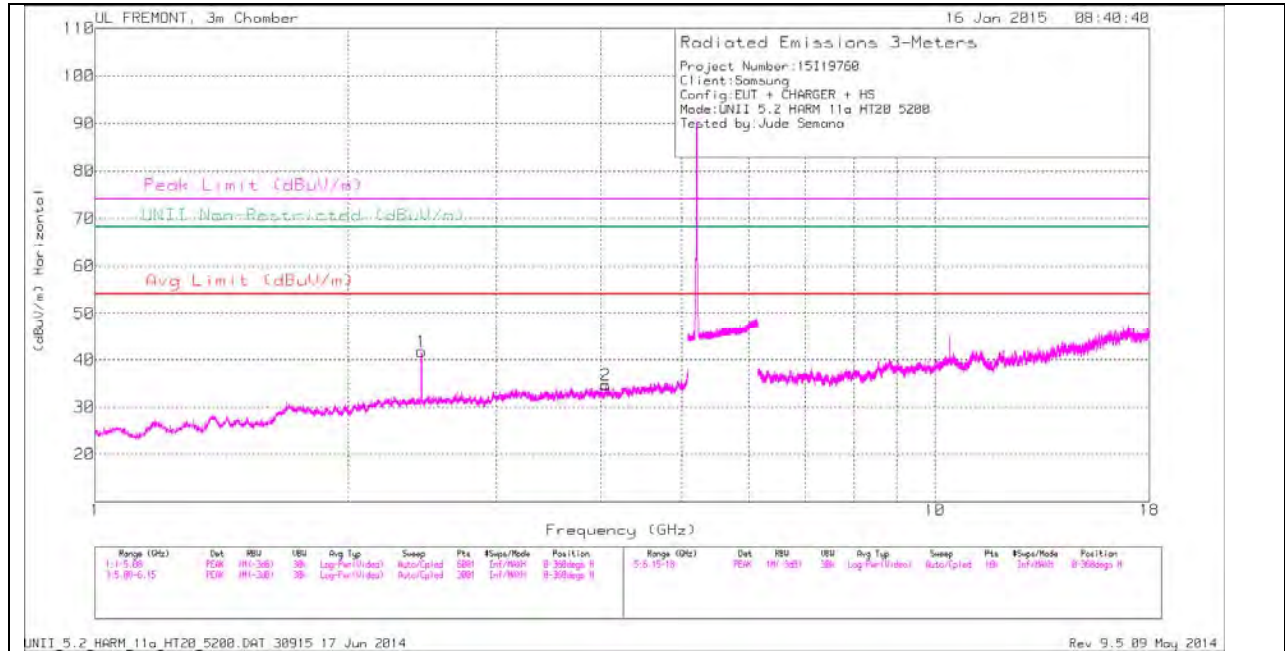

Note: Emission was scanned up to 40GHz; No emissions were detected above the noise floor which was at least 20dB below the specification limit.

MID CHANNEL VERTICAL

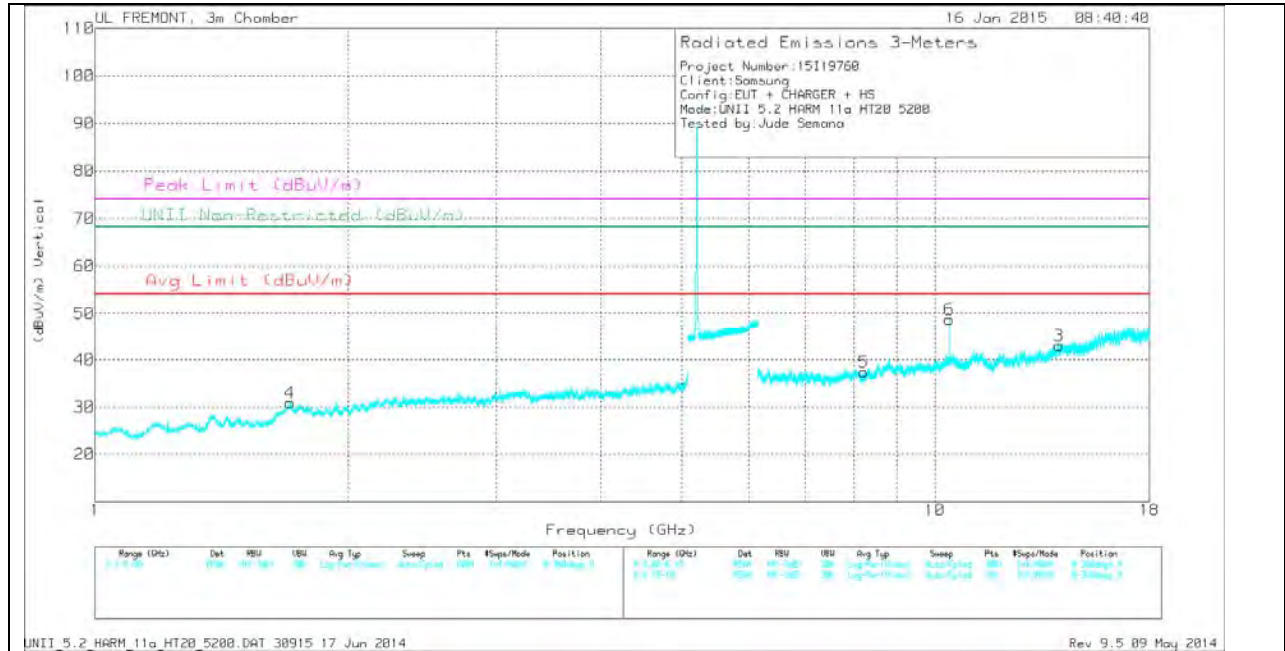

Note: Emission was scanned up to 40GHz; No emissions were detected above the noise floor which was at least 20dB below the specification limit.

MID CHANNEL DATA

TRACE MARKERS

Marker	Frequency (GHz)	Meter Reading (dBuV)	Det	AF T711 (dB/m)	Amp/Cbl/Ftr/Pad (dB)	DC Corr (dB)	Corrected Reading (dBuV/m)	Avg Limit (dBuV/m)	Margin (dB)	Peak Limit (dBuV/m)	PK Margin (dB)	UNII Non-Restricted (dBuV/m)	PK Margin (dB)	Azimuth (Degs)	Height (cm)	Polarity
4	1.707	32.24	PK	30.7	-32	0	30.94	-	-	74	-43.06	-	-	0-360	200	V
1	2.446	42.18	PK	32.1	-32.5	0	41.78	-	-	-	-	68.2	-26.42	0-360	200	H
2	4.056	32.3	PK	33.2	-30.8	0	34.7	-	-	74	-39.3	-	-	0-360	100	H
5	8.227	30.03	PK	36.1	-28.7	0	37.43	-	-	74	-36.57	-	-	0-360	100	V
6	10.4	36.55	PK	38	-25.8	0	48.75	-	-	-	-	68.2	-19.45	0-360	100	V
3	14.048	31.11	PK	39.6	-27.7	0	43.01	-	-	-	-	68.2	-25.19	0-360	200	V

PK - Peak detector

Radiated Emissions

Frequency (GHz)	Meter Reading (dBuV)	Det	AF T711 (dB/m)	Amp/Cbl/Ftr/Pad (dB)	DC Corr (dB)	Corrected Reading (dBuV/m)	Avg Limit (dBuV/m)	Margin (dB)	Peak Limit (dBuV/m)	PK Margin (dB)	UNII Non-Restricted (dBuV/m)	PK Margin (dB)	Azimuth (Degs)	Height (cm)	Polarity
10.4	41.88	PK1	38	-25.8	0	54.08	-	-	-	-	68.2	-14.12	8	329	V
10.4	36.73	AD1	38	-25.8	.32	49.23	-	-	-	-	-	-	8	329	V

PK1 - KDB789033 Method: Peak

AD1 - KDB789033 Method: AD Primary Power Average

HIGH CHANNEL HORIZONTAL

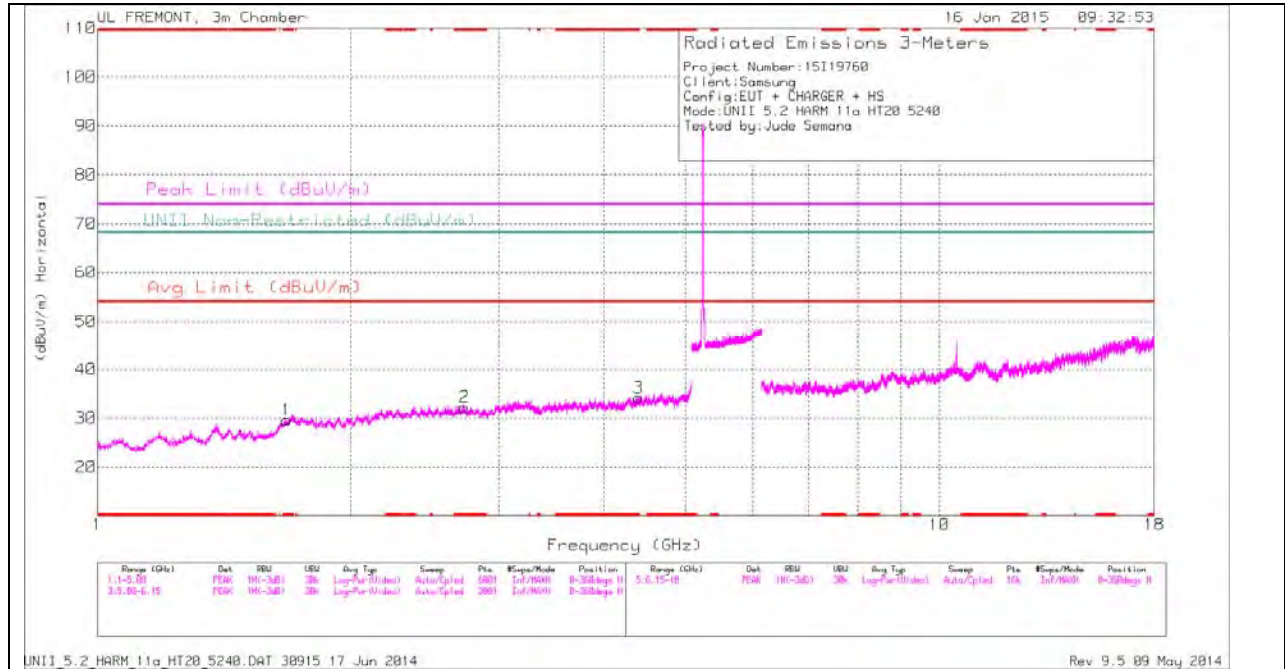

Note: Emission was scanned up to 40GHz; No emissions were detected above the noise floor which was at least 20dB below the specification limit.

HIGH CHANNEL VERTICAL

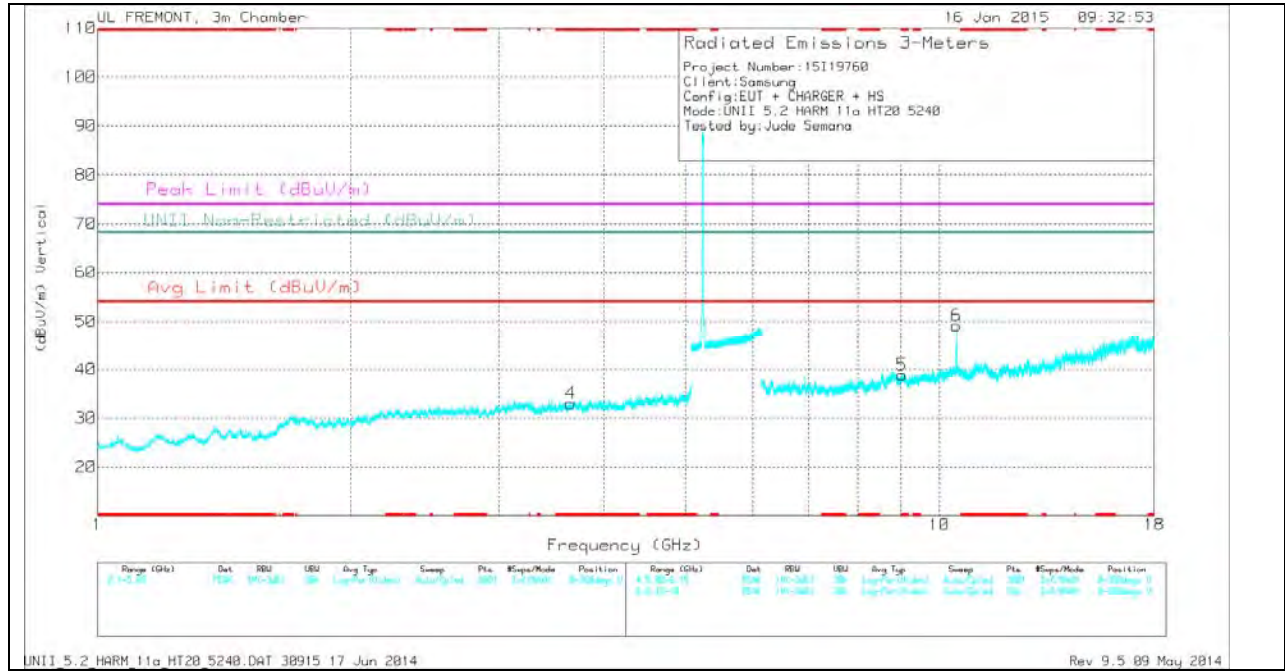

Note: Emission was scanned up to 40GHz; No emissions were detected above the noise floor which was at least 20dB below the specification limit.

HIGH CHANNEL DATA

TRACE MARKERS

Marker	Frequency (GHz)	Meter Reading (dBuV)	Det	AF T711 (dB/m)	Amp/Cbl/Ftr/Pad (dB)	DC Corr (dB)	Corrected Reading (dBuV/m)	Avg Limit (dBuV/m)	Margin (dB)	Peak Limit (dBuV/m)	PK Margin (dB)	UNII Non-Restricted (dBuV/m)	PK Margin (dB)	Azimuth (Degs)	Height (cm)	Polarity
1	* 1.679	32.07	PK	30.1	-32.5	0	29.67	-	-	74	-44.33	-	-	0-360	200	H
2	* 2.732	32.01	PK	32.4	-32.2	0	32.21	-	-	74	-41.79	-	-	0-360	100	H
3	* 4.393	31.57	PK	33.5	-30.9	0	34.17	-	-	74	-39.83	-	-	0-360	200	H
4	* 3.651	30.98	PK	33	-31	0	32.98	-	-	74	-41.02	-	-	0-360	200	V
5	* 9.032	27.64	PK	36.6	-25.4	0	38.84	-	-	74	-35.16	-	-	0-360	200	V
6	10.48	36.75	PK	38.1	-25.7	0	49.15	-	-	-	-	68.2	-19.05	0-360	100	V

* - indicates frequency in CFR15.205/IC7.2.2 Restricted Band

PK - Peak detector

Radiated Emissions

Frequency (GHz)	Meter Reading (dBuV)	Det	AF T711 (dB/m)	Amp/Cbl/Ftr/Pad (dB)	DC Corr (dB)	Corrected Reading (dBuV/m)	Avg Limit (dBuV/m)	Margin (dB)	Peak Limit (dBuV/m)	PK Margin (dB)	UNII Non-Restricted (dBuV/m)	PK Margin (dB)	Azimuth (Degs)	Height (cm)	Polarity
10.48	40.69	PK1	38.1	-25.7	0	53.09	-	-	-	-	68.2	-15.11	215	267	V
10.48	35.03	AD1	38.1	-25.7	.32	47.73	-	-	-	-	-	-	215	267	V

* - indicates frequency in CFR15.205/IC7.2.2 Restricted Band

PK1 - KDB789033 Method: Peak

AD1 - KDB789033 Method: AD Primary Power Average

**11.1.2. TX ABOVE 1 GHz 802.11n HT20 MODE IN THE 5.2 GHz BAND
 RESTRICTED BANDEDGE (LOW CHANNEL)**

HORIZONTAL PEAK AND AVERAGE PLOT

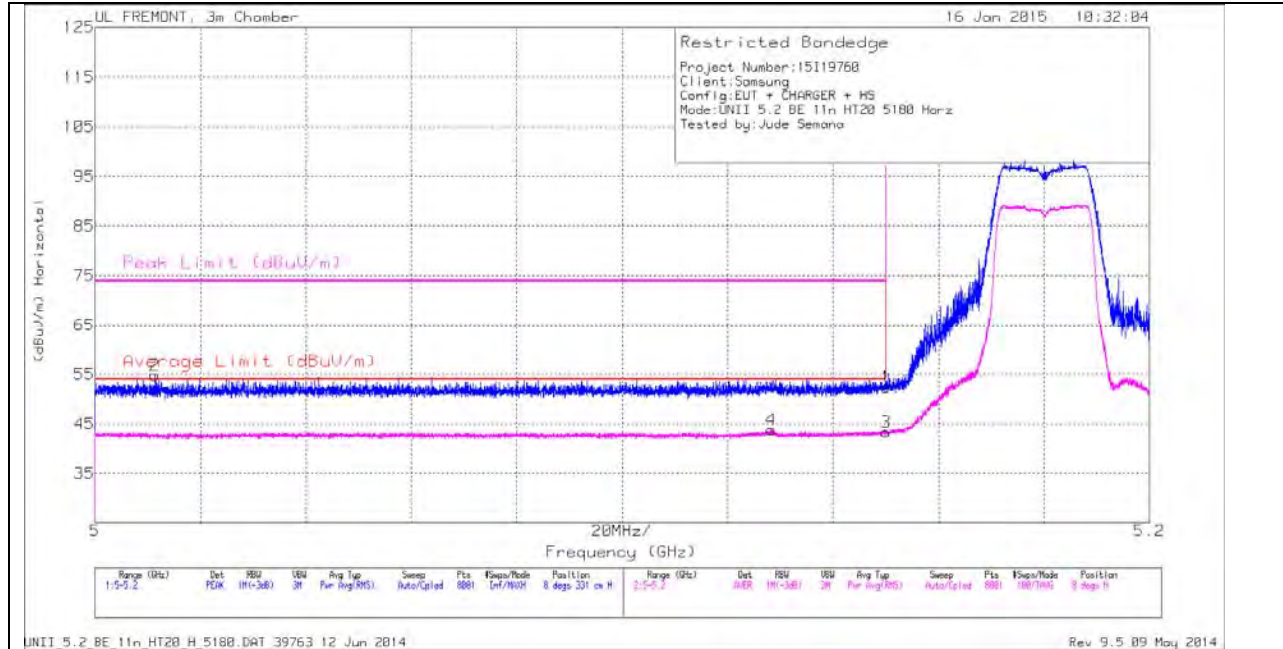

HORIZONTAL DATA

Marker	Frequency (GHz)	Meter Reading (dBuV)	Det	AF T711 (dB/m)	Amp/Cb/Fit r/Pad (dB)	DC Corr (dB)	Corrected Reading (dBuV/m)	Average Limit (dBuV/m)	Margin (dB)	Peak Limit (dBuV/m)	PK Margin (dB)	Azimuth (Degs)	Height (cm)	Polarity
2	5.011	42.25	PK	34	-21.5	0	54.75	-	-	74	-19.25	8	331	H
4	5.128	30.72	RMS	34.2	-21.5	.33	43.72	54	-10.28	-	-	8	331	H
1	5.15	39.79	PK	34.2	-21.6	0	52.39	-	-	74	-21.61	8	331	H
3	5.15	30.33	RMS	34.2	-21.6	.33	43.23	54	-10.77	-	-	8	331	H

VERTICAL PEAK AND AVERAGE PLOT

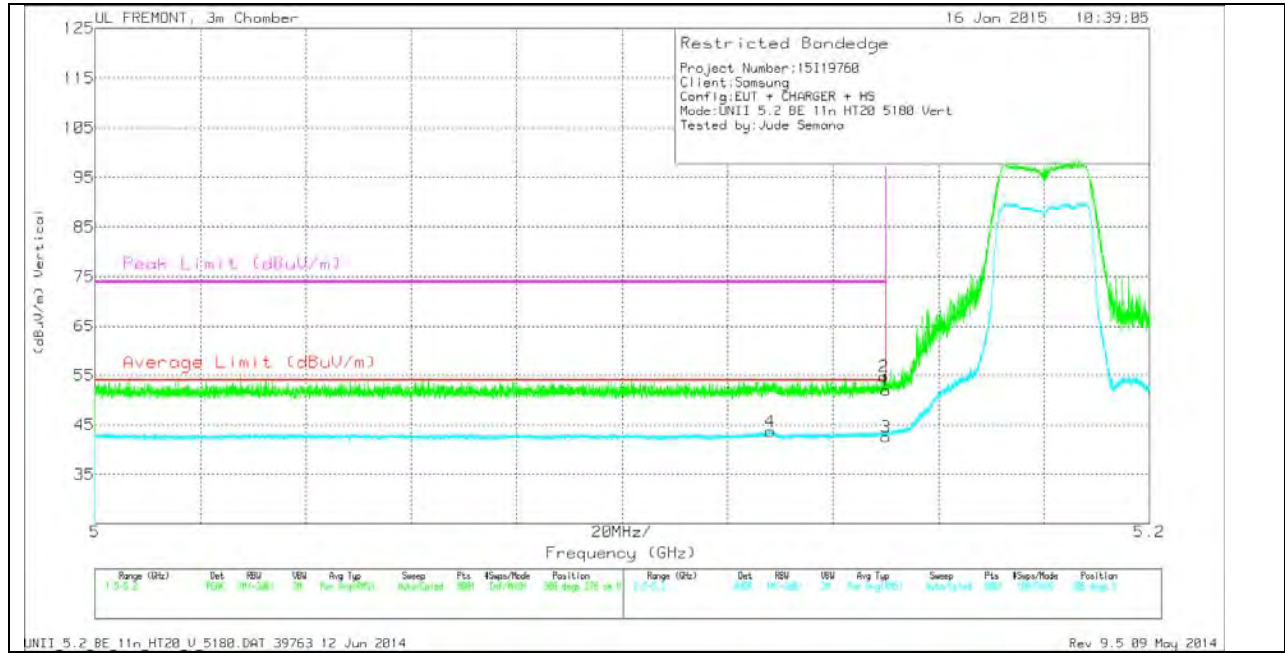

VERTICAL DATA

Marker	Frequency (GHz)	Meter Reading (dBuV)	Det	AF T711 (dB/m)	Amp/Cbl/Fit r/Pad (dB)	DC Corr (dB)	Corrected Reading (dBuV/m)	Average Limit (dBuV/m)	Margin (dB)	Peak Limit (dBuV/m)	PK Margin (dB)	Azimuth (Degs)	Height (cm)	Polarity
4	5.128	30.6	RMS	34.2	-21.5	.33	43.6	54	-10.4	-	-	306	276	V
1	5.15	39.36	PK	34.2	-21.6	0	51.96	-	-	74	-22.04	306	276	V
2	5.15	42.08	PK	34.2	-21.6	0	54.68	-	-	74	-19.32	306	276	V
3	5.15	29.57	RMS	34.2	-21.6	.33	42.47	54	-11.53	-	-	306	276	V

HARMONICS AND SPURIOUS EMISSIONS

LOW CHANNEL HORIZONTAL

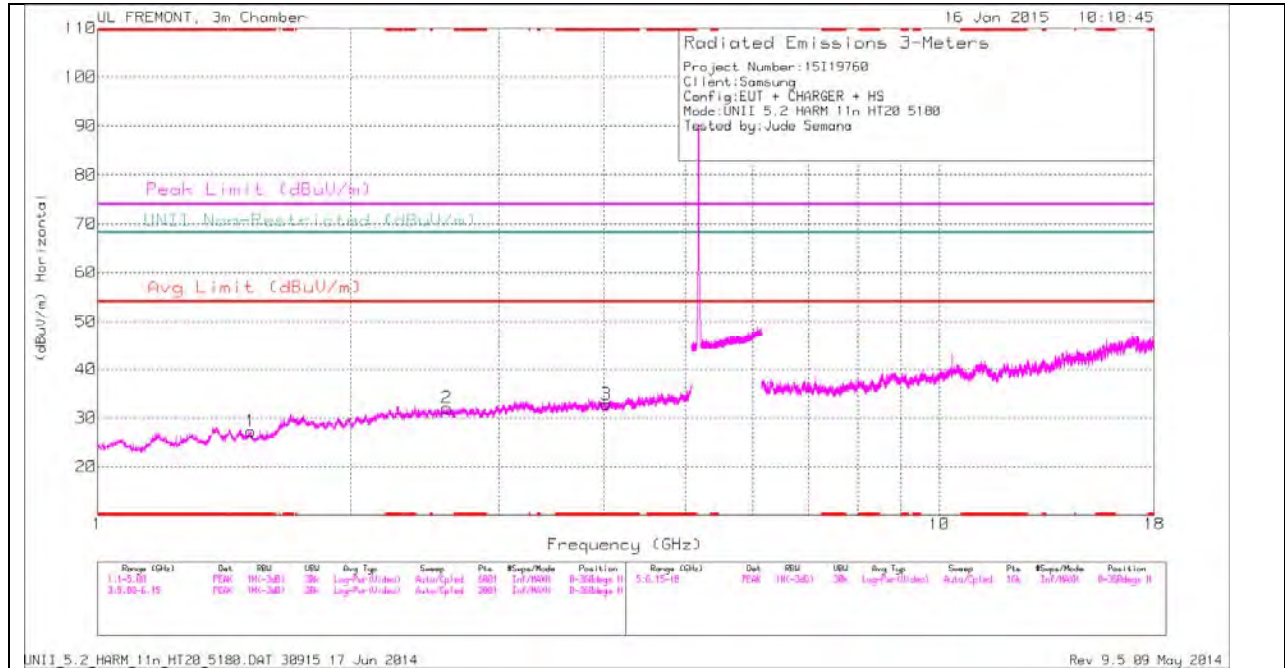

Note: Emission was scanned up to 40GHz; No emissions were detected above the noise floor which was at least 20dB below the specification limit.

LOW CHANNEL VERTICAL

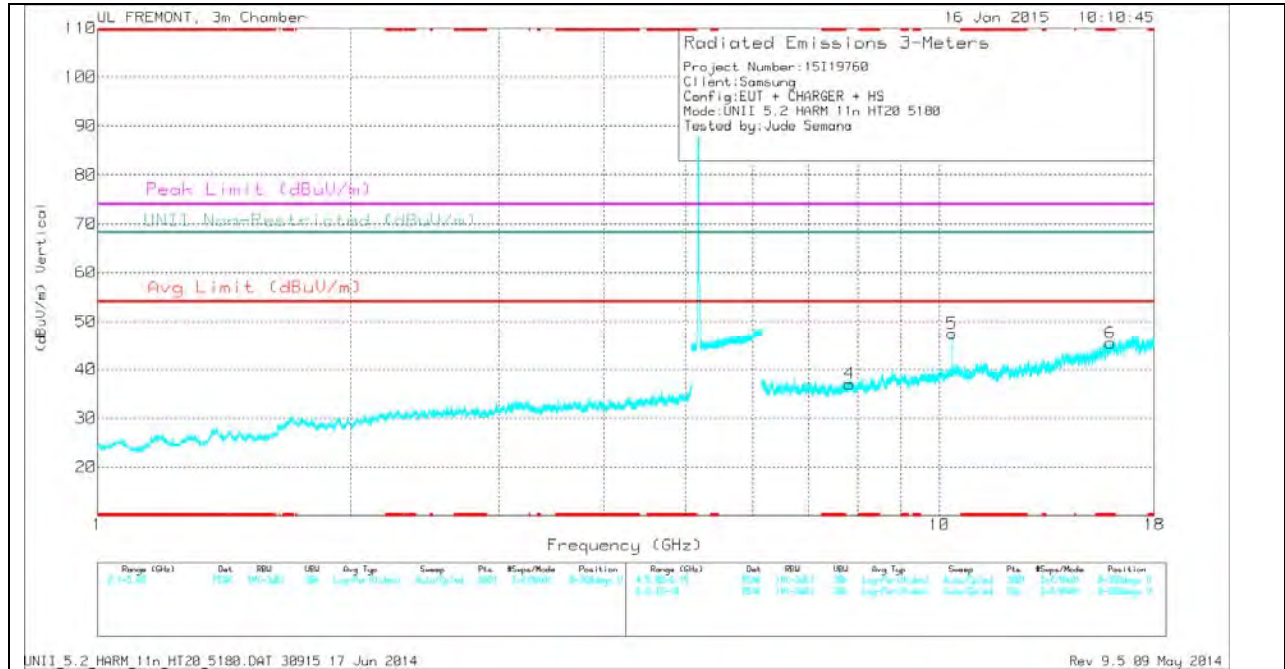

Note: Emission was scanned up to 40GHz; No emissions were detected above the noise floor which was at least 20dB below the specification limit.

LOW CHANNEL DATA

TRACE MARKERS

Marker	Frequency (GHz)	Meter Reading (dBuV)	Det	AF T711 (dB/m)	Amp/Cbl/Ftr/Pad (dB)	DC Corr (dB)	Corrected Reading (dBuV/m)	Avg Limit (dBuV/m)	Margin (dB)	Peak Limit (dBuV/m)	PK Margin (dB)	UNII Non-Restricted (dBuV/m)	PK Margin (dB)	Azimuth (Degs)	Height (cm)	Polarity
1	* 1.522	32.78	PK	27.7	-33.2	0	27.28	-	-	74	-46.72	-	-	0-360	100	H
3	* 4.023	31.11	PK	33.2	-31.5	0	32.81	-	-	74	-41.19	-	-	0-360	100	H
6	* 15.962	29.44	PK	41.9	-25.9	0	45.44	-	-	74	-28.56	-	-	0-360	200	V
2	2.601	32.18	PK	32.3	-32.4	0	32.08	-	-	-	-	68.2	-36.12	0-360	100	H
4	7.826	29.32	PK	35.8	-28.1	0	37.02	-	-	-	-	68.2	-31.18	0-360	200	V
5	10.359	34.95	PK	37.9	-25.4	0	47.45	-	-	-	-	68.2	-20.75	0-360	200	V

* - indicates frequency in CFR15.205/IC7.2.2 Restricted Band

PK - Peak detector

Radiated Emissions

Frequency (GHz)	Meter Reading (dBuV)	Det	AF T711 (dB/m)	Amp/Cbl/Ftr/Pad (dB)	DC Corr (dB)	Corrected Reading (dBuV/m)	Avg Limit (dBuV/m)	Margin (dB)	Peak Limit (dBuV/m)	PK Margin (dB)	UNII Non-Restricted (dBuV/m)	PK Margin (dB)	Azimuth (Degs)	Height (cm)	Polarity
10.36	41.2	PK1	38	-25.4	0	53.8	-	-	-	-	68.2	-14.4	0	364	V
10.36	35.96	AD1	38	-25.4	.33	48.86	-	-	-	-	-	-	0	364	V

* - indicates frequency in CFR15.205/IC7.2.2 Restricted Band

PK1 - KDB789033 Method: Peak

AD1 - KDB789033 Method: AD Primary Power Average

MID CHANNEL HORIZONTAL

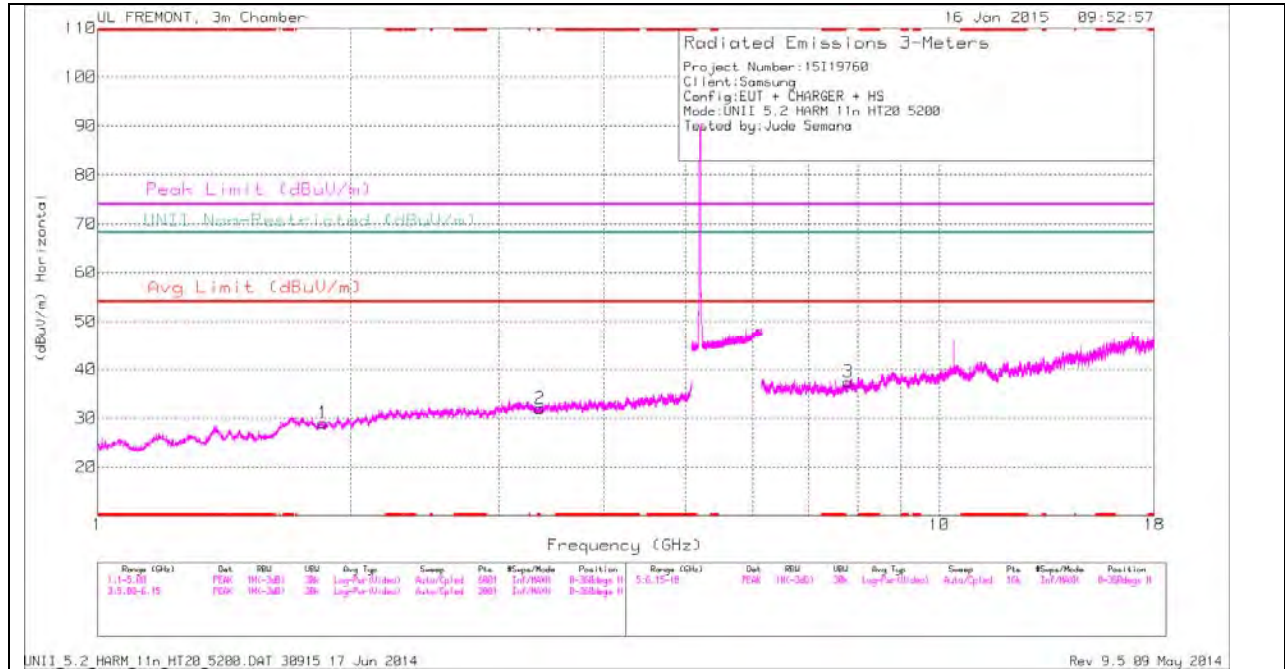

Note: Emission was scanned up to 40GHz; No emissions were detected above the noise floor which was at least 20dB below the specification limit.

MID CHANNEL VERTICAL

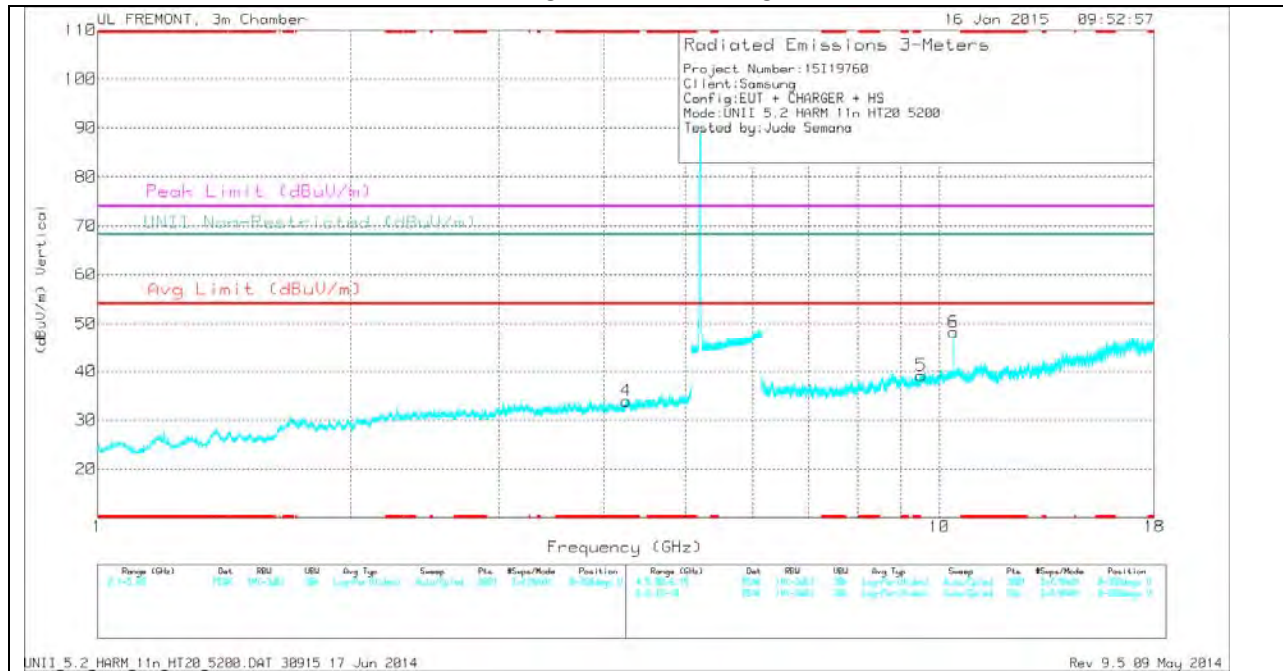

Note: Emission was scanned up to 40GHz; No emissions were detected above the noise floor which was at least 20dB below the specification limit.

MID CHANNEL DATA

TRACE MARKERS

Marker	Frequency (GHz)	Meter Reading (dBuV)	Det	AF T711 (dB/m)	Amp/Cbl/Ftr/Pad (dB)	DC Corr (dB)	Corrected Reading (dBuV/m)	Avg Limit (dBuV/m)	Margin (dB)	Peak Limit (dBuV/m)	PK Margin (dB)	UNII Non-Restricted (dBuV/m)	PK Margin (dB)	Azimuth (Degs)	Height (cm)	Polarity
2	* 3.357	31.32	PK	32.7	-32	0	32.02	-	-	74	-41.98	-	-	0-360	100	H
4	* 4.25	31.57	PK	33.4	-31	0	33.97	-	-	74	-40.03	-	-	0-360	200	V
1	1.855	32.08	PK	30.3	-33.3	0	29.08	-	-	-	-	68.2	-39.12	0-360	100	H
3	7.799	30.06	PK	35.8	-28.4	0	37.46	-	-	-	-	68.2	-30.74	0-360	200	H
5	9.525	27.96	PK	37	-25.8	0	39.16	-	-	-	-	68.2	-29.04	0-360	100	V
6	10.4	36.03	PK	38	-25.8	0	48.23	-	-	-	-	68.2	-19.97	0-360	100	V

* - indicates frequency in CFR15.205/IC7.2.2 Restricted Band

PK - Peak detector

Radiated Emissions

Frequency (GHz)	Meter Reading (dBuV)	Det	AF T711 (dB/m)	Amp/Cbl/Ftr/Pad (dB)	DC Corr (dB)	Corrected Reading (dBuV/m)	Avg Limit (dBuV/m)	Margin (dB)	Peak Limit (dBuV/m)	PK Margin (dB)	UNII Non-Restricted (dBuV/m)	PK Margin (dB)	Azimuth (Degs)	Height (cm)	Polarity
10.4	41.35	PK1	38	-25.8	0	53.55	-	-	-	-	68.2	-14.65	15	267	V
10.4	35.46	AD1	38	-25.8	.33	47.96	-	-	-	-	-	-	15	267	V

* - indicates frequency in CFR15.205/IC7.2.2 Restricted Band

PK1 - KDB789033 Method: Peak

AD1 - KDB789033 Method: AD Primary Power Average

HIGH CHANNEL HORIZONTAL

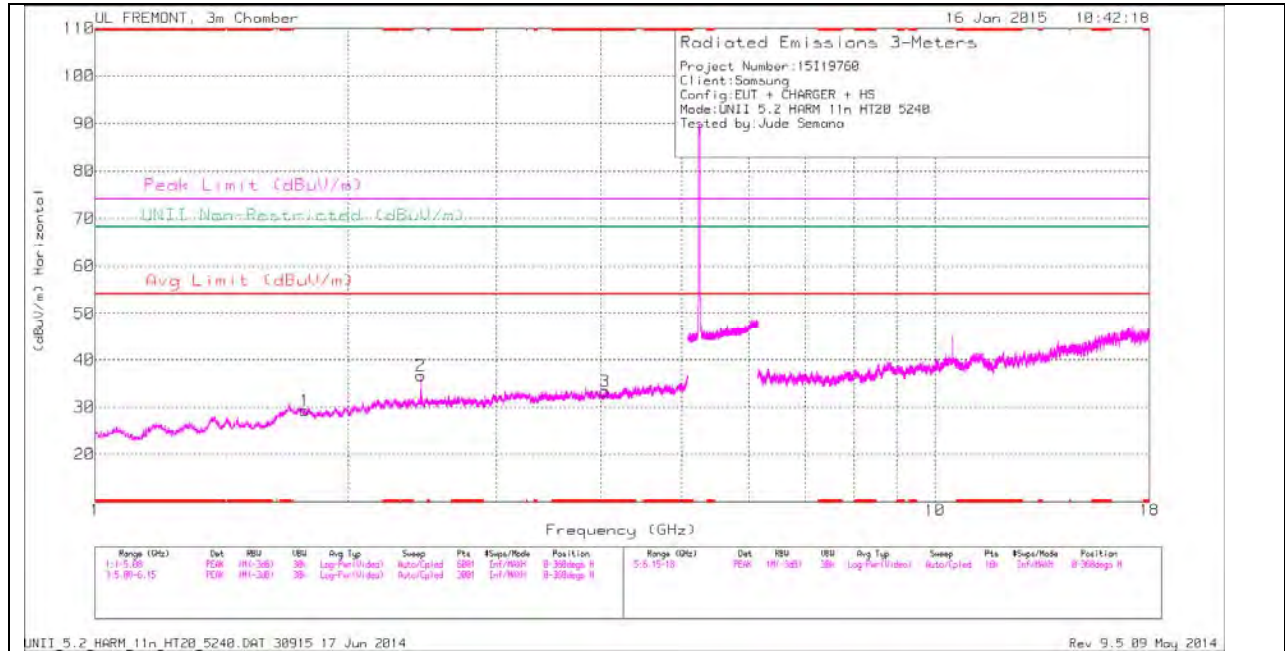

Note: Emission was scanned up to 40GHz; No emissions were detected above the noise floor which was at least 20dB below the specification limit.

HIGH CHANNEL VERTICAL

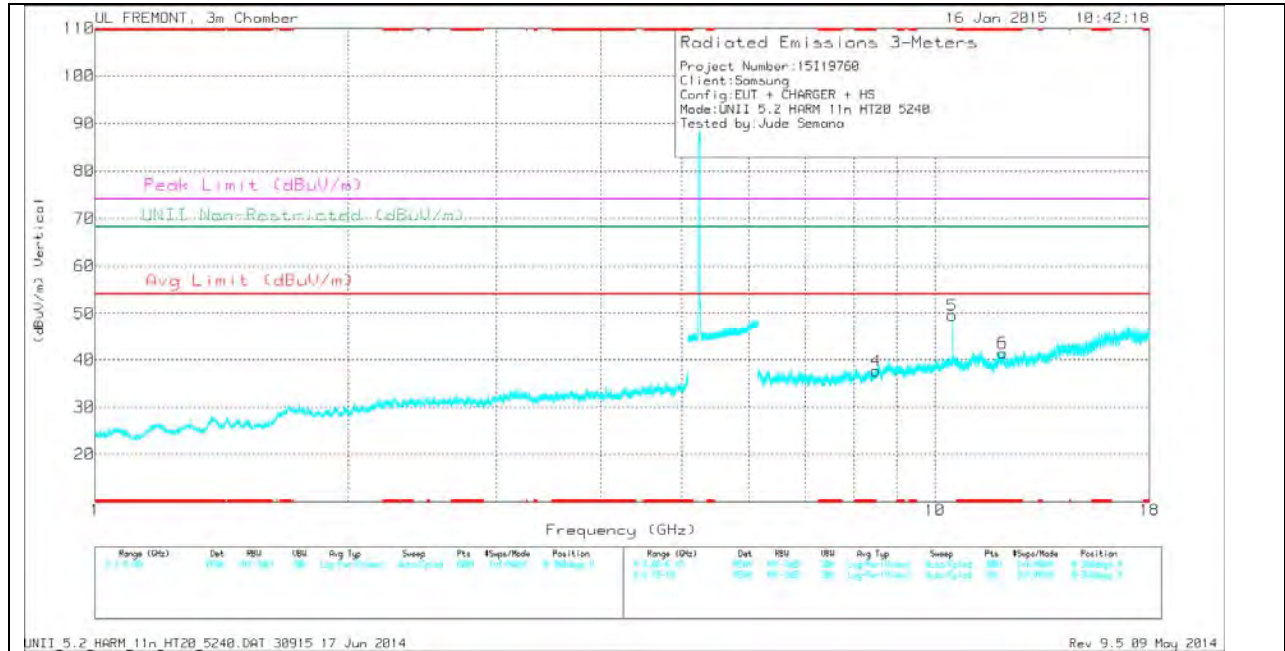

Note: Emission was scanned up to 40GHz; No emissions were detected above the noise floor which was at least 20dB below the specification limit.

HIGH CHANNEL DATA

TRACE MARKERS

Marker	Frequency (GHz)	Meter Reading (dBuV)	Det	AF T711 (dB/m)	Amp/Cbl/Ftr/Pad (dB)	DC Corr (dB)	Corrected Reading (dBuV/m)	Avg Limit (dBuV/m)	Margin (dB)	Peak Limit (dBuV/m)	PK Margin (dB)	UNII Non-Restricted (dBuV/m)	PK Margin (dB)	Azimuth (Degs)	Height (cm)	Polarity
3	* 4.047	31.36	PK	33.2	-31.2	0	33.36	-	-	74	-40.64	-	-	0-360	100	H
6	* 12.038	29.12	PK	38.5	-26.2	0	41.42	-	-	74	-32.58	-	-	0-360	200	V
1	1.777	31.31	PK	30.4	-32.4	0	29.31	-	-	-	-	68.2	-38.89	0-360	100	H
2	2.442	36.97	PK	32.1	-32.4	0	36.67	-	-	-	-	68.2	-31.53	0-360	200	H
4	8.502	28.96	PK	36.2	-27.5	0	37.66	-	-	-	-	68.2	-30.54	0-360	200	V
5	10.48	37.18	PK	38.1	-25.7	0	49.58	-	-	-	-	68.2	-18.62	0-360	100	V

* - indicates frequency in CFR15.205/IC7.2.2 Restricted Band

PK - Peak detector

Radiated Emissions

Frequency (GHz)	Meter Reading (dBuV)	Det	AF T711 (dB/m)	Amp/Cbl/Ftr/Pad (dB)	DC Corr (dB)	Corrected Reading (dBuV/m)	Avg Limit (dBuV/m)	Margin (dB)	Peak Limit (dBuV/m)	PK Margin (dB)	UNII Non-Restricted (dBuV/m)	PK Margin (dB)	Azimuth (Degs)	Height (cm)	Polarity
10.48	41.36	PK1	38.1	-25.7	0	53.76	-	-	-	-	68.2	-14.44	212	102	V
10.48	35.64	AD1	38.1	-25.7	.33	48.34	-	-	-	-	-	-	212	102	V

* - indicates frequency in CFR15.205/IC7.2.2 Restricted Band

PK1 - KDB789033 Method: Peak

AD1 - KDB789033 Method: AD Primary Power Average

**11.1.3. TX ABOVE 1 GHz 802.11n HT40 MODE IN THE 5.2 GHz BAND
 RESTRICTED BANDEDGE (LOW CHANNEL)**

HORIZONTAL PEAK AND AVERAGE PLOT

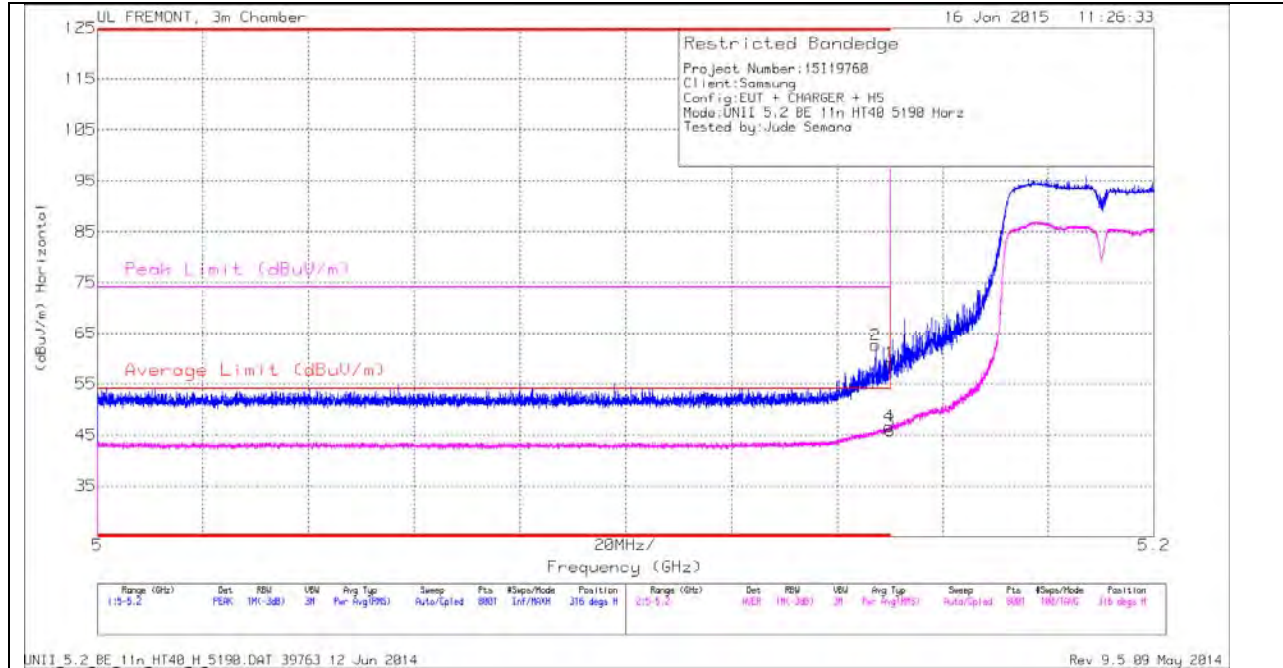

HORIZONTAL DATA

Marker	Frequency (GHz)	Meter Reading (dBuV)	Det	AF T711 (dB/m)	Amp/Cbl/Fitter/Pad (dB)	DC Corr (dB)	Corrected Reading (dBuV/m)	Average Limit (dBuV/m)	Margin (dB)	Peak Limit (dBuV/m)	PK Margin (dB)	Azimuth (Degs)	Height (cm)	Polarity
1	* 5.15	46.47	PK	34.2	-21.6	0	59.07	-	-	74	-14.93	316	232	H
2	* 5.147	50.01	PK	34.2	-21.6	0	62.61	-	-	74	-11.39	316	232	H
3	* 5.15	32.55	RMS	34.2	-21.6	.64	45.75	54	-8.25	-	-	316	232	H
4	* 5.15	33.37	RMS	34.2	-21.6	.64	46.77	54	-7.43	-	-	316	232	H

VERTICAL PEAK AND AVERAGE PLOT

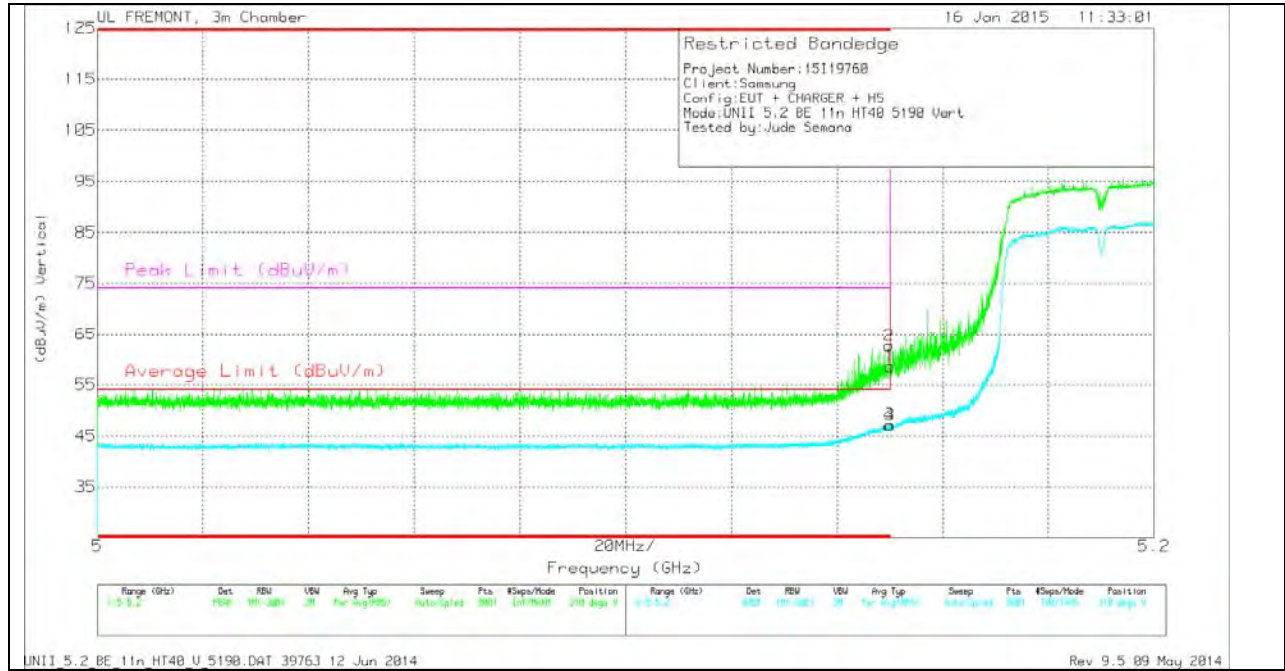

VERTICAL DATA

Marker	Frequency (GHz)	Meter Reading (dBuV)	Det	AF T711 (dB/m)	Amp/Cb/Filter/Pad (dB)	DC Corr (dB)	Corrected Reading (dBuV/m)	Average Limit (dBuV/m)	Margin (dB)	Peak Limit (dBuV/m)	PK Margin (dB)	Azimuth (Degs)	Height (cm)	Polarity
1	* 5.15	45.99	PK	34.2	-21.6	0	58.59	-	-	74	-15.41	310	275	V
2	* 5.15	50.11	PK	34.2	-21.6	0	62.71	-	-	74	-11.29	310	275	V
3	* 5.15	33.88	RMS	34.2	-21.6	.64	47.08	54	-6.72	-	-	310	275	V
4	* 5.15	33.82	RMS	34.2	-21.6	.64	47.02	54	-6.78	-	-	310	275	V

HARMONICS AND SPURIOUS EMISSIONS

LOW CHANNEL HORIZONTAL

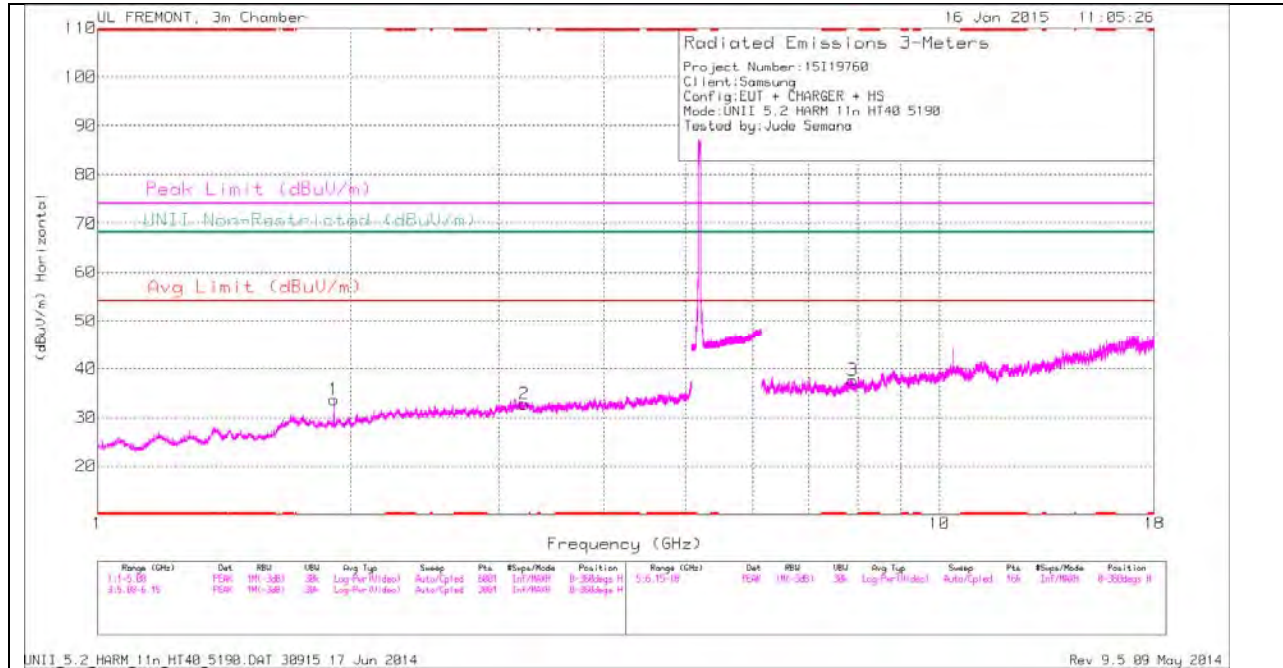

Note: Emission was scanned up to 40GHz; No emissions were detected above the noise floor which was at least 20dB below the specification limit.

LOW CHANNEL VERTICAL

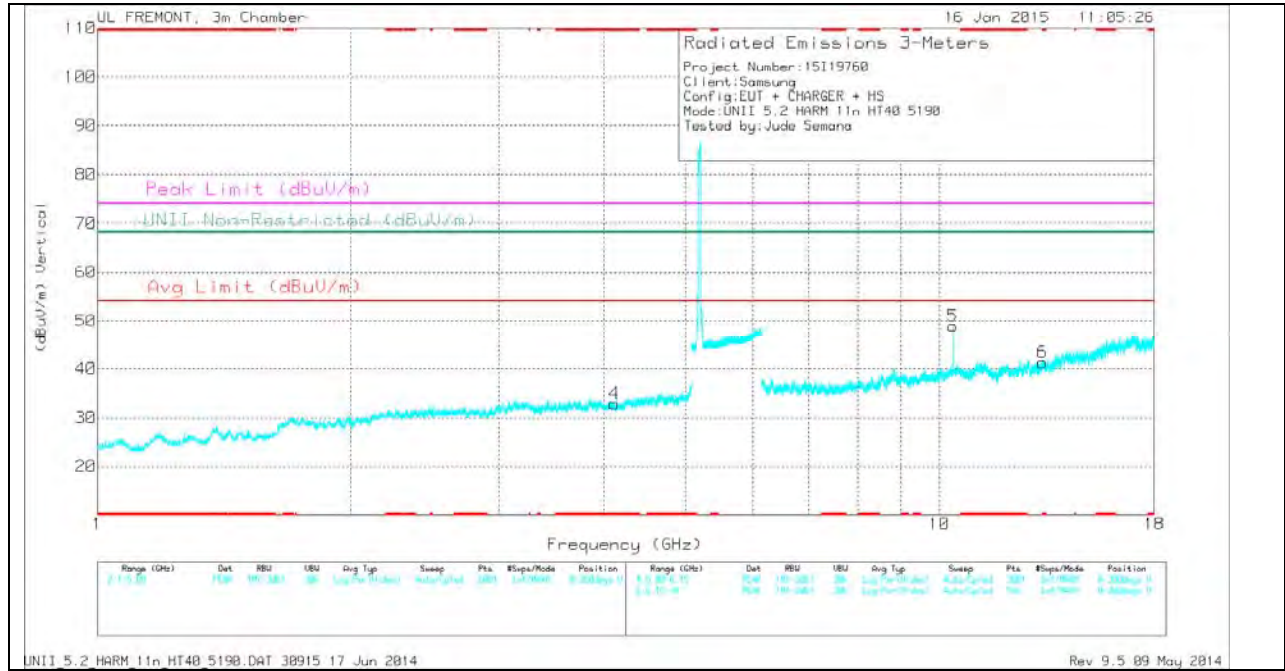

Note: Emission was scanned up to 40GHz; No emissions were detected above the noise floor which was at least 20dB below the specification limit.

LOW CHANNEL DATA

TRACE MARKERS

Marker	Frequency (GHz)	Meter Reading (dBuV)	Det	AF T711 (dB/m)	Amp/Cbl/Ftr/Pad (dB)	DC Corr (dB)	Corrected Reading (dBuV/m)	Avg Limit (dBuV/m)	Margin (dB)	Peak Limit (dBuV/m)	PK Margin (dB)	UNII Non-Restricted (dBuV/m)	PK Margin (dB)	Azimuth (Degs)	Height (cm)	Polarity
4	* 4.114	30.43	PK	33.2	-30.8	0	32.83	-	-	74	-41.17	-	-	0-360	200	V
6	* 13.26	28.83	PK	38.8	-26.3	0	41.33	-	-	74	-32.67	-	-	0-360	200	V
1	1.91	36.12	PK	30.2	-32.7	0	33.62	-	-	-	-	68.2	-34.58	0-360	200	H
2	3.215	30.99	PK	33.1	-31.3	0	32.79	-	-	-	-	68.2	-35.41	0-360	200	H
3	7.891	29.64	PK	35.9	-27.9	0	37.64	-	-	-	-	68.2	-30.56	0-360	100	H
5	10.379	36.57	PK	38	-25.6	0	48.97	-	-	-	-	68.2	-19.23	0-360	200	V

* - indicates frequency in CFR15.205/IC7.2.2 Restricted Band

PK - Peak detector

Radiated Emissions

Frequency (GHz)	Meter Reading (dBuV)	Det	AF T711 (dB/m)	Amp/Cbl/Ftr/Pad (dB)	DC Corr (dB)	Corrected Reading (dBuV/m)	Avg Limit (dBuV/m)	Margin (dB)	Peak Limit (dBuV/m)	PK Margin (dB)	UNII Non-Restricted (dBuV/m)	PK Margin (dB)	Azimuth (Degs)	Height (cm)	Polarity
10.38	41.69	PK1	38	-25.6	0	54.09	-	-	-	-	68.2	-14.11	0	381	V
10.38	36.18	AD1	38	-25.6	.64	49.18	-	-	-	-	-	-	0	381	V

* - indicates frequency in CFR15.205/IC7.2.2 Restricted Band

PK1 - KDB789033 Method: Peak

AD1 - KDB789033 Method: AD Primary Power Average

MID CHANNEL HORIZONTAL

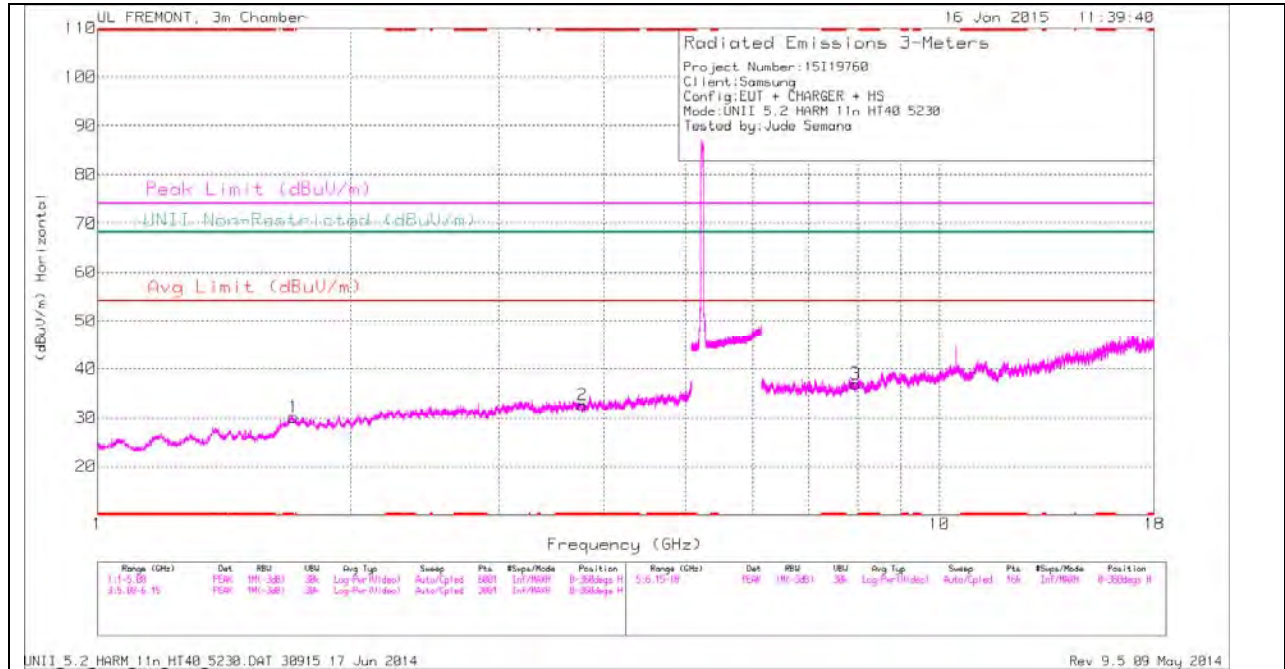

Note: Emission was scanned up to 40GHz; No emissions were detected above the noise floor which was at least 20dB below the specification limit.

MID CHANNEL VERTICAL

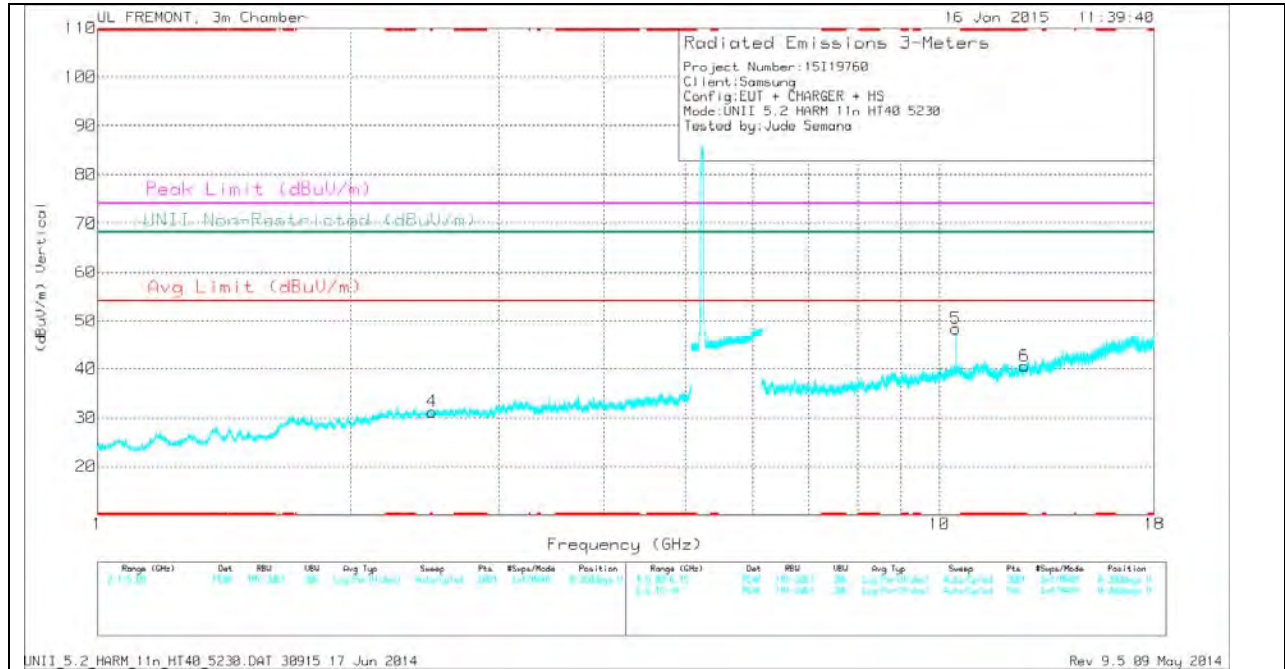

Note: Emission was scanned up to 40GHz; No emissions were detected above the noise floor which was at least 20dB below the specification limit.

MID CHANNEL DATA

TRACE MARKERS

Marker	Frequency (GHz)	Meter Reading (dBuV)	Det	AF T711 (dB/m)	Amp/Cbl/Ftr/Pad (dB)	DC Corr (dB)	Corrected Reading (dBuV/m)	Avg Limit (dBuV/m)	Margin (dB)	Peak Limit (dBuV/m)	PK Margin (dB)	UNII Non-Restricted (dBuV/m)	PK Margin (dB)	Azimuth (Degs)	Height (cm)	Polarity
2	* 3.769	31.46	PK	32.9	-31.8	0	32.56	-	-	74	-41.44	-	-	0-360	200	H
4	* 2.499	31.03	PK	32.1	-31.9	0	31.23	-	-	74	-42.77	-	-	0-360	200	V
6	* 12.626	28.68	PK	38.8	-26.9	0	40.58	-	-	74	-33.42	-	-	0-360	200	V
1	1.711	31.51	PK	30.7	-32.1	0	30.11	-	-	-	-	68.2	-38.09	0-360	100	H
3	7.958	29.56	PK	35.9	-28.6	0	36.86	-	-	-	-	68.2	-31.34	0-360	100	H
5	10.46	36.06	PK	38.1	-25.7	0	48.46	-	-	-	-	68.2	-19.74	0-360	100	V

* - indicates frequency in CFR15.205/IC7.2.2 Restricted Band

PK - Peak detector

Radiated Emissions

Frequency (GHz)	Meter Reading (dBuV)	Det	AF T711 (dB/m)	Amp/Cbl/Ftr/Pad (dB)	DC Corr (dB)	Corrected Reading (dBuV/m)	Avg Limit (dBuV/m)	Margin (dB)	Peak Limit (dBuV/m)	PK Margin (dB)	UNII Non-Restricted (dBuV/m)	PK Margin (dB)	Azimuth (Degs)	Height (cm)	Polarity
10.46	40.9	PK1	38.1	-25.7	0	53.3	-	-	-	-	68.2	-14.9	210	100	V
10.46	35.2	AD1	38.1	-25.7	.64	48.2	-	-	-	-	-	-	210	100	V

* - indicates frequency in CFR15.205/IC7.2.2 Restricted Band

PK1 - KDB789033 Method: Peak

AD1 - KDB789033 Method: AD Primary Power Average

11.2. 5.3 GHz

11.2.1. TX ABOVE 1 GHz 802.11a MODE IN THE 5.3 GHz BAND

AUTHORIZED BANDEDGE (HIGH CHANNEL)

HORIZONTAL PEAK AND AVERAGE PLOT

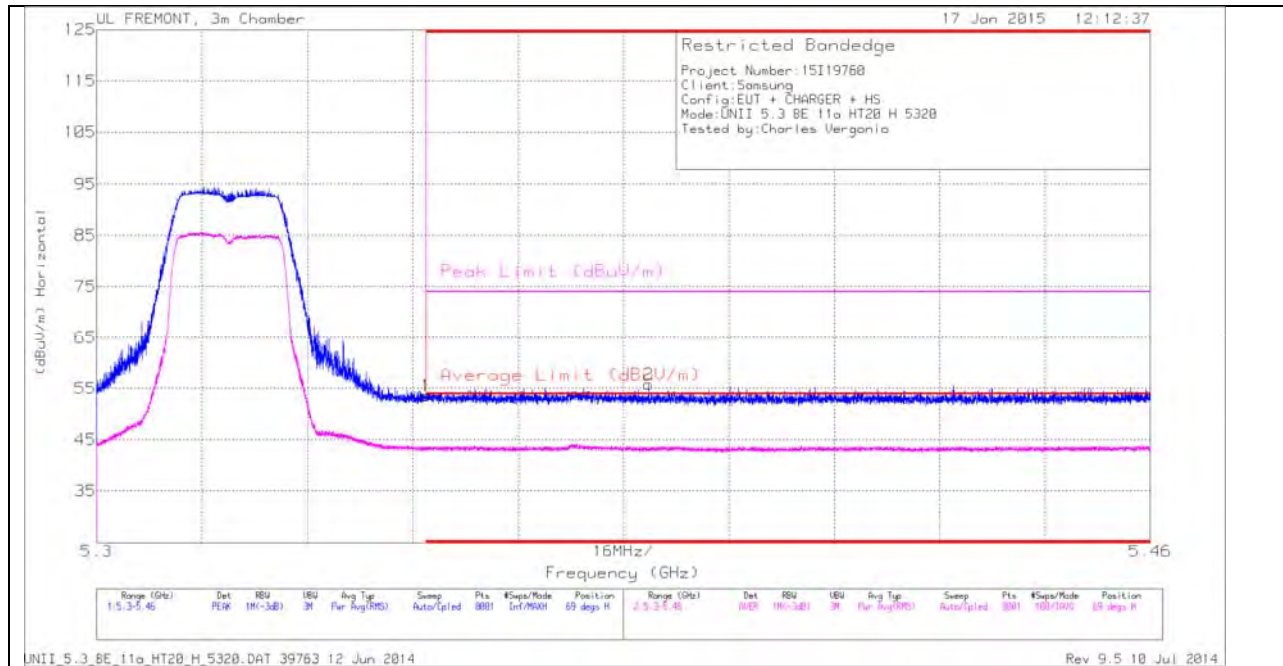

HORIZONTAL DATA

Marker	Frequency (GHz)	Meter Reading (dBuV)	Det	AF T711 (dB/m)	Amp/Cb/Flt r/Pad (dB)	DC Corr (dB)	Corrected Reading (dBuV/m)	Average Limit (dBuV/m)	Margin (dB)	Peak Limit (dBuV/m)	PK Margin (dB)	Azimuth (Degs)	Height (cm)	Polarity
1	* 5.35	40.64	PK	34.3	-21.4	0	53.54	-	-	74	-20.46	69	197	H
3	* 5.35	30.03	RMS	34.3	-21.4	.32	43.23	54	-10.77	-	-	69	197	H
4	* 5.372	31.2	RMS	34.3	-21.5	.32	44.3	54	-9.7	-	-	69	197	H
2	* 5.384	42.85	PK	34.3	-21.4	0	55.75	-	-	74	-18.25	69	197	H

VERTICAL PEAK AND AVERAGE PLOT

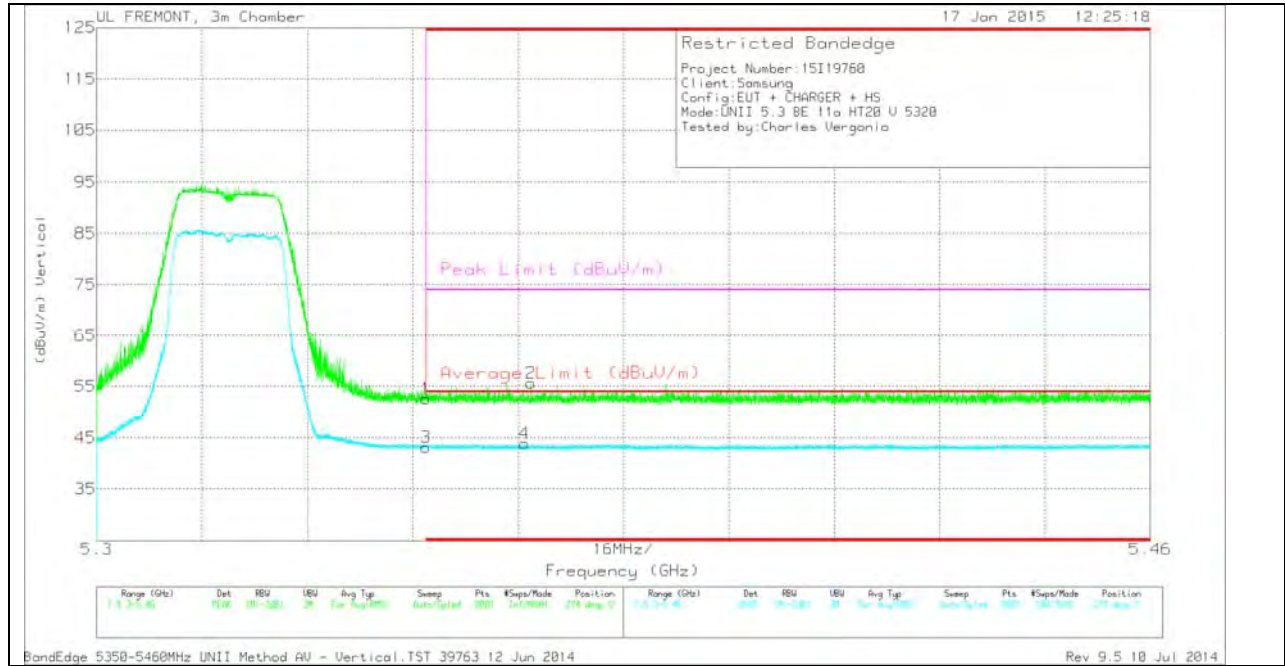

VERTICAL DATA

Marker	Frequency (GHz)	Meter Reading (dBuV)	Det	AF T711 (dB/m)	Amp/Cb/Fit r/Pad (dB)	DC Corr (dB)	Corrected Reading (dBuV/m)	Average Limit (dBuV/m)	Margin (dB)	Peak Limit (dBuV/m)	PK Margin (dB)	Azimuth (Degs)	Height (cm)	Polarity
1	* 5.35	39.65	PK	34.3	-21.4	0	52.55	-	-	74	-21.45	274	198	V
3	* 5.35	29.92	RMS	34.3	-21.4	.32	43.12	54	-10.88	-	-	274	198	V
4	* 5.365	30.8	RMS	34.3	-21.5	.32	43.9	54	-10.1	-	-	274	198	V
2	* 5.366	42.83	PK	34.3	-21.5	0	55.63	-	-	74	-18.37	274	198	V

HARMONICS AND SPURIOUS EMISSIONS

LOW CHANNEL HORIZONTAL

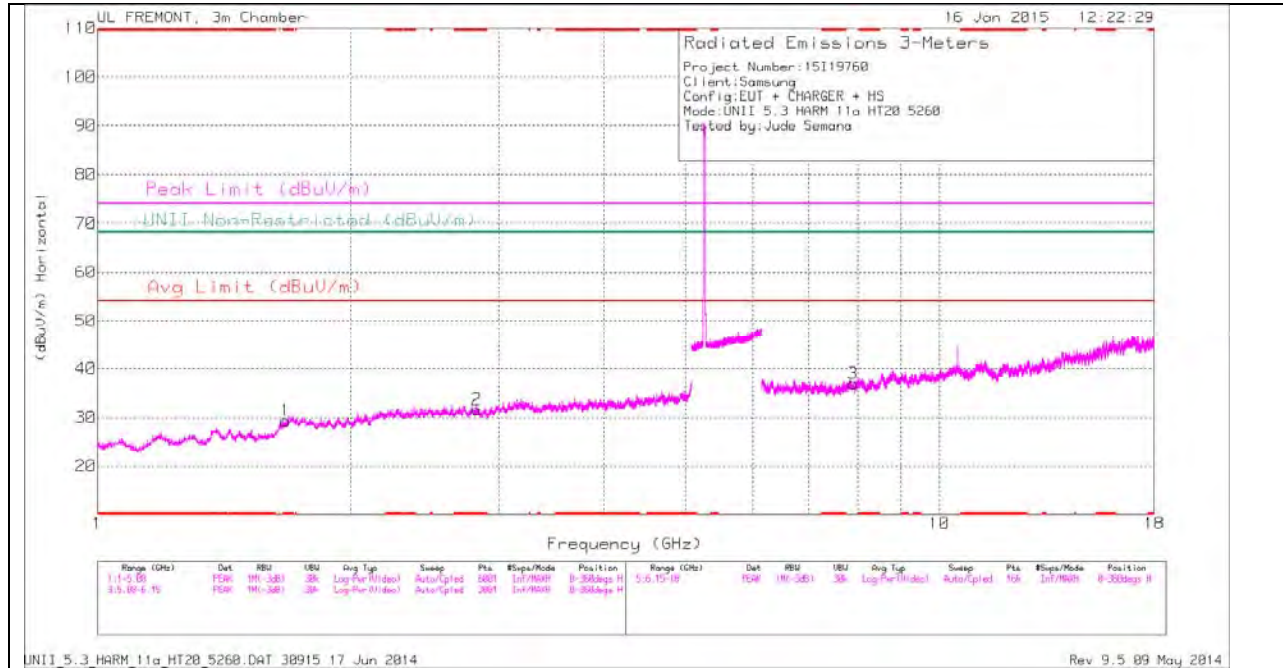

Note: Emission was scanned up to 40GHz; No emissions were detected above the noise floor which was at least 20dB below the specification limit.

LOW CHANNEL VERTICAL

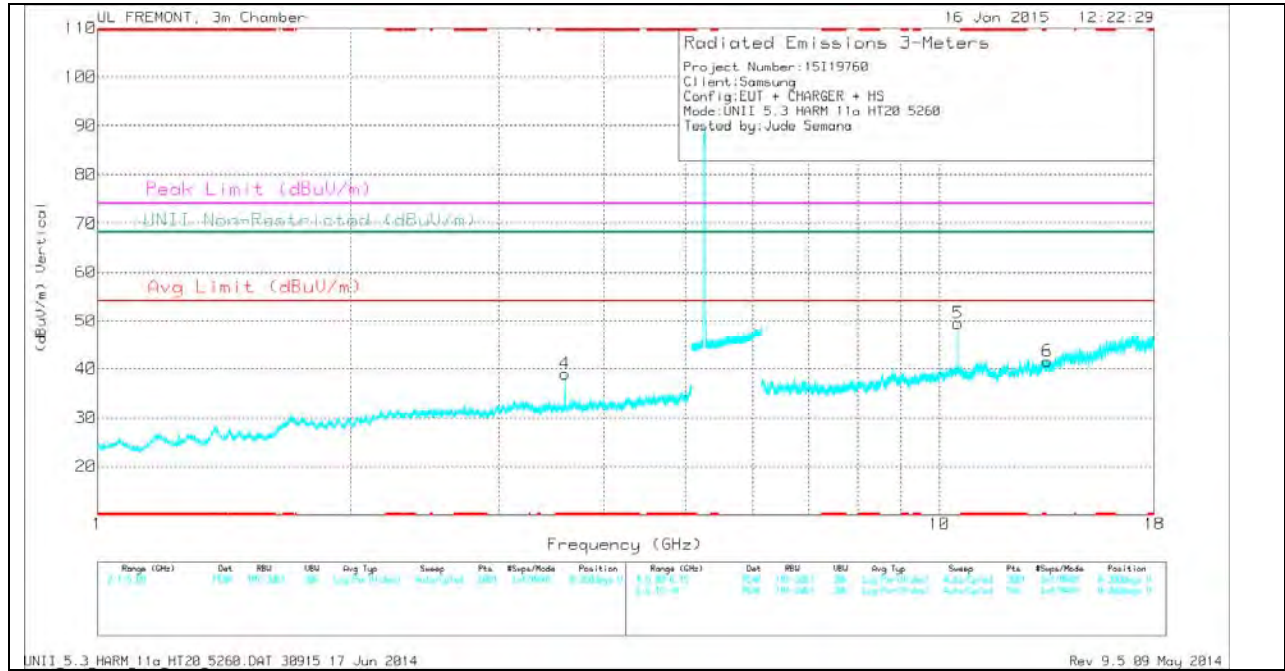

Note: Emission was scanned up to 40GHz; No emissions were detected above the noise floor which was at least 20dB below the specification limit.

LOW CHANNEL DATA

Trace Markers

Marker	Frequency (GHz)	Meter Reading (dBuV)	Det	AF T711 (dB/m)	Amp/Cbl/Ftr/Pad (dB)	DC Corr (dB)	Corrected Reading (dBuV/m)	Avg Limit (dBuV/m)	Margin (dB)	Peak Limit (dBuV/m)	PK Margin (dB)	UNII Non-Restricted (dBuV/m)	PK Margin (dB)	Azimuth (Degs)	Height (cm)	Polarity
1	* 1.675	31.82	PK	29.9	-32.4	0	29.32	-	-	74	-44.68	-	-	0-360	100	H
2	* 2.824	31.81	PK	32.2	-32.4	0	31.61	-	-	74	-42.39	-	-	0-360	100	H
4	* 3.594	37.56	PK	33.2	-31.8	0	38.96	-	-	74	-35.04	-	-	0-360	200	V
3	7.904	29.12	PK	35.9	-28.1	0	36.92	-	-	-	-	68.2	-31.28	0-360	100	H
5	10.52	36.41	PK	38.1	-25	0	49.51	-	-	-	-	68.2	-18.69	0-360	100	V
6	13.444	30.26	PK	38.9	-27.6	0	41.56	-	-	-	-	68.2	-26.64	0-360	100	V

* - indicates frequency in CFR15.205/IC7.2.2 Restricted Band

PK - Peak detector

Radiated Emissions

Frequency (GHz)	Meter Reading (dBuV)	Det	AF T711 (dB/m)	Amp/Cbl/Ftr/Pad (dB)	DC Corr (dB)	Corrected Reading (dBuV/m)	Avg Limit (dBuV/m)	Margin (dB)	Peak Limit (dBuV/m)	PK Margin (dB)	UNII Non-Restricted (dBuV/m)	PK Margin (dB)	Azimuth (Degs)	Height (cm)	Polarity
10.52	39.96	PK1	38.1	-25	0	53.06	-	-	-	-	68.2	-15.14	214	101	V
10.52	34.12	AD1	38.1	-25	-32	47.52	-	-	-	-	-	-	214	101	V

* - indicates frequency in CFR15.205/IC7.2.2 Restricted Band

PK1 - KDB789033 Method: Peak

AD1 - KDB789033 Method: AD Primary Power Average

MID CHANNEL HORIZONTAL

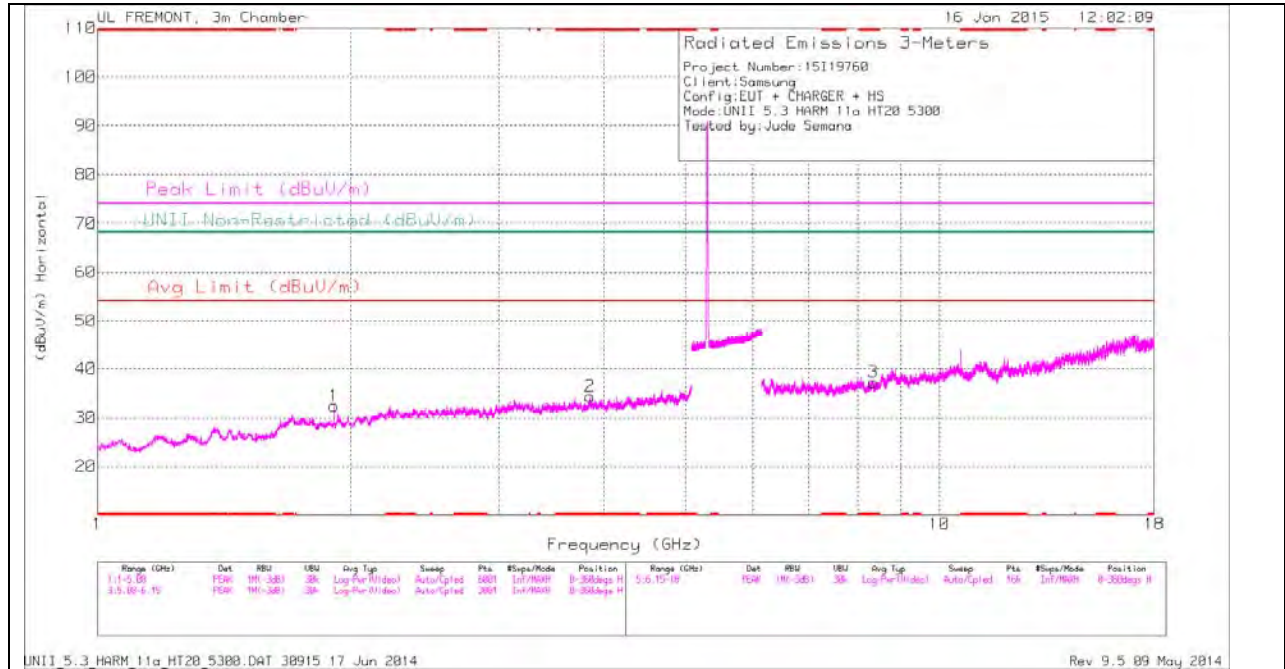

Note: Emission was scanned up to 40GHz; No emissions were detected above the noise floor which was at least 20dB below the specification limit.

MID CHANNEL VERTICAL

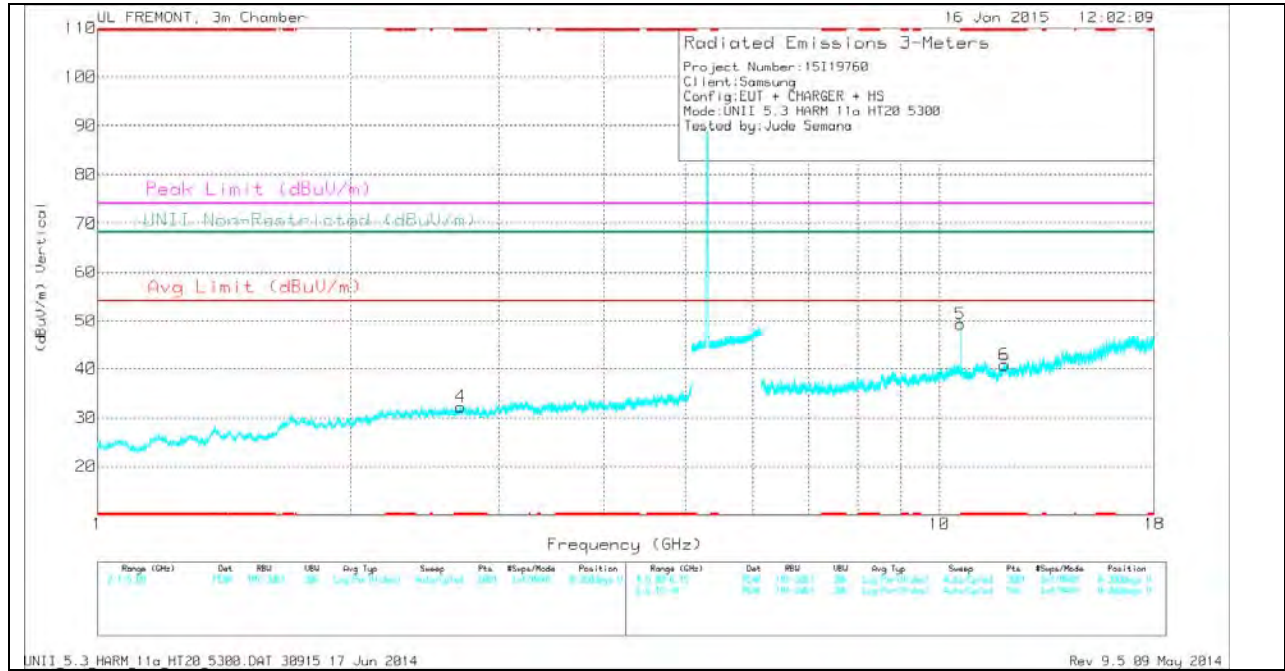

Note: Emission was scanned up to 40GHz; No emissions were detected above the noise floor which was at least 20dB below the specification limit.

MID CHANNEL DATA

Trace Markers

Marker	Frequency (GHz)	Meter Reading (dBuV)	Det	AF T711 (dB/m)	Amp/Cbl/Ftr/Pad (dB)	DC Corr (dB)	Corrected Reading (dBuV/m)	Avg Limit (dBuV/m)	Margin (dB)	Peak Limit (dBuV/m)	PK Margin (dB)	UNII Non-Restricted (dBuV/m)	PK Margin (dB)	Azimuth (Degs)	Height (cm)	Polarity
2	* 3.848	32.27	PK	33	-30.9	0	34.37	-	-	74	-39.63	-	-	0-360	100	H
4	* 2.701	31.92	PK	32.4	-32.1	0	32.22	-	-	74	-41.78	-	-	0-360	200	V
3	* 8.347	27.87	PK	36.1	-26.7	0	37.27	-	-	74	-36.73	-	-	0-360	200	H
5	* 10.6	36.54	PK	38.1	-25.3	0	49.34	-	-	74	-24.66	-	-	0-360	100	V
6	* 11.955	28.81	PK	38.4	-26.4	0	40.81	-	-	74	-33.19	-	-	0-360	200	V
1	1.911	35.04	PK	30.2	-32.8	0	32.44	-	-	-	-	68.2	-35.76	0-360	100	H

* - indicates frequency in CFR15.205/IC7.2.2 Restricted Band

PK - Peak detector

Radiated Emissions

Frequency (GHz)	Meter Reading (dBuV)	Det	AF T711 (dB/m)	Amp/Cbl/Ftr/Pad (dB)	DC Corr (dB)	Corrected Reading (dBuV/m)	Avg Limit (dBuV/m)	Margin (dB)	Peak Limit (dBuV/m)	PK Margin (dB)	UNII Non-Restricted (dBuV/m)	PK Margin (dB)	Azimuth (Degs)	Height (cm)	Polarity
* 10.6	41.9	PK1	38.1	-25.3	0	54.7	-	-	74	-19.3	-	-	213	246	V
* 10.6	36.67	AD1	38.1	-25.3	.32	49.77	54	-4.23	-	-	-	-	213	246	V

* - indicates frequency in CFR15.205/IC7.2.2 Restricted Band

PK1 - KDB789033 Method: Peak

AD1 - KDB789033 Method: AD Primary Power Average

HIGH CHANNEL HORIZONTAL

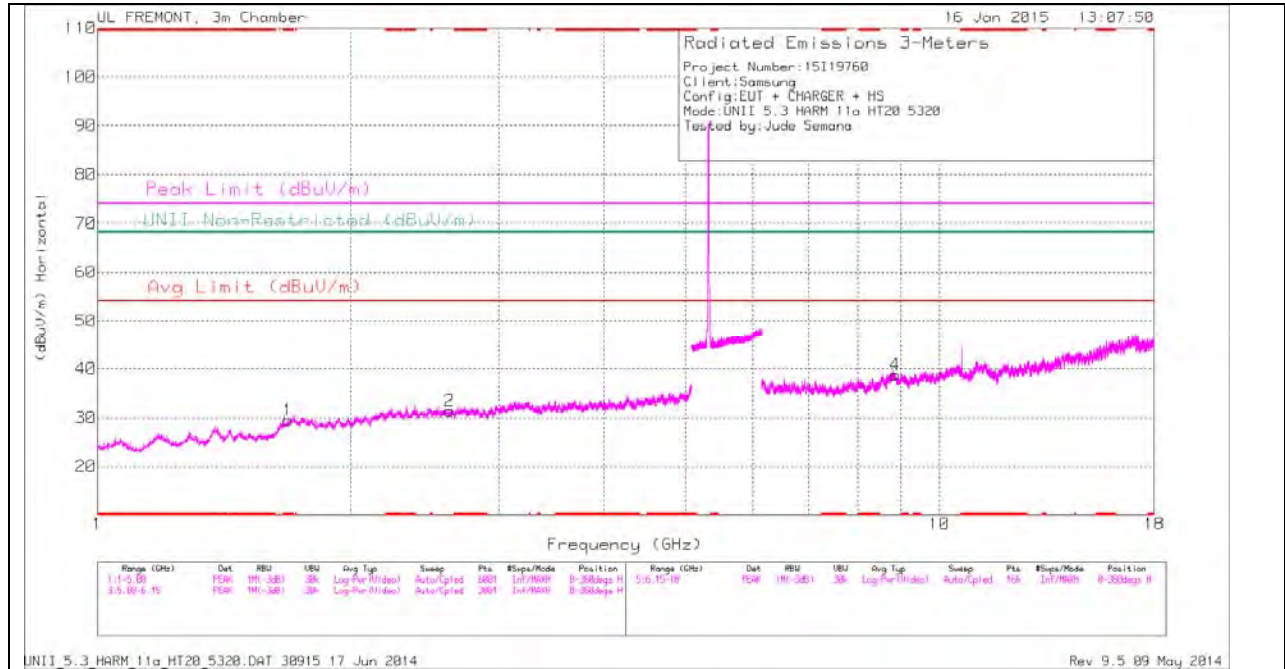

Note: Emission was scanned up to 40GHz; No emissions were detected above the noise floor which was at least 20dB below the specification limit.

HIGH CHANNEL VERTICAL

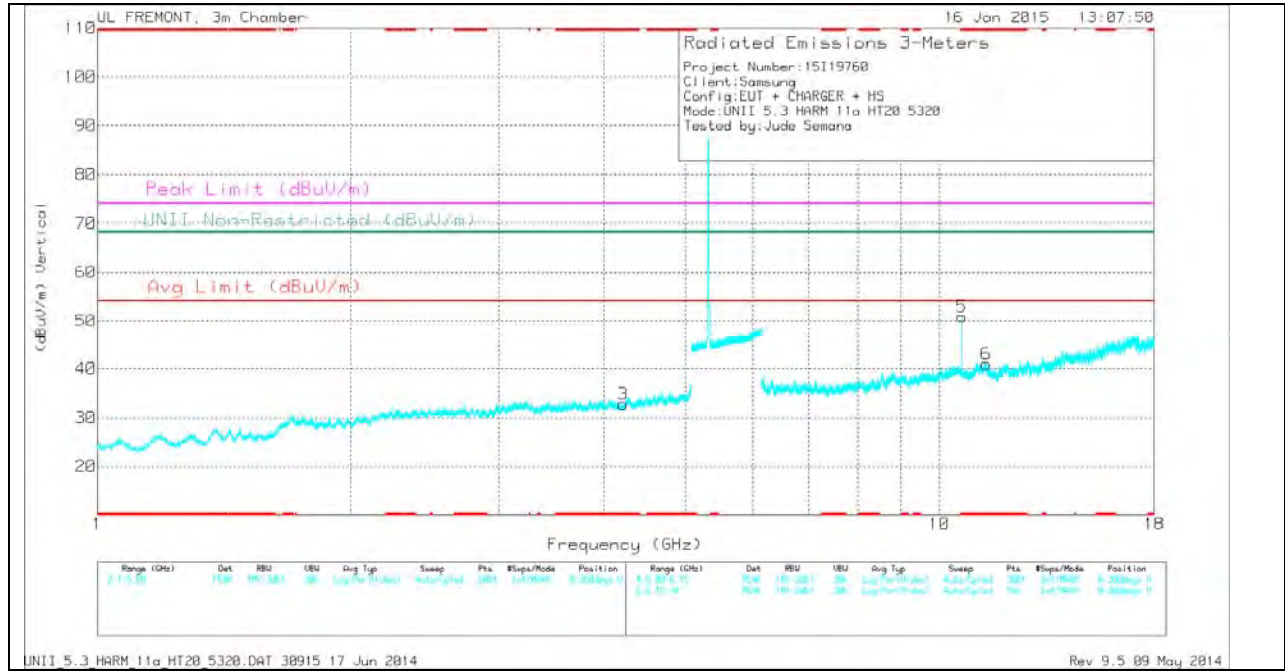

Note: Emission was scanned up to 40GHz; No emissions were detected above the noise floor which was at least 20dB below the specification limit.

HIGH CHANNEL DATA

Trace Markers

Marker	Frequency (GHz)	Meter Reading (dBuV)	Det	AF T711 (dB/m)	Amp/Cbl/Ftr/Pad (dB)	DC Corr (dB)	Corrected Reading (dBuV/m)	Avg Limit (dBuV/m)	Margin (dB)	Peak Limit (dBuV/m)	PK Margin (dB)	UNII Non-Restricted (dBuV/m)	PK Margin (dB)	Azimuth (Degs)	Height (cm)	Polarity
1	* 1.685	31.55	PK	30.3	-32.4	0	29.45	-	-	74	-44.55	-	-	0-360	200	H
3	* 4.213	30.84	PK	33.3	-31.4	0	32.74	-	-	74	-41.26	-	-	0-360	100	V
5	* 10.639	37.86	PK	38.1	-25.1	0	50.86	-	-	74	-23.14	-	-	0-360	100	V
6	* 11.375	28.87	PK	38.2	-26.1	0	40.97	-	-	74	-33.03	-	-	0-360	200	V
2	2.621	31.52	PK	32.3	-32.5	0	31.32	-	-	-	-	68.2	-36.88	0-360	200	H
4	8.867	28.63	PK	36.6	-26.5	0	38.73	-	-	-	-	68.2	-29.47	0-360	100	H

* - indicates frequency in CFR15.205/IC7.2.2 Restricted Band

PK - Peak detector

Radiated Emissions

Frequency (GHz)	Meter Reading (dBuV)	Det	AF T711 (dB/m)	Amp/Cbl/Ftr/Pad (dB)	DC Corr (dB)	Corrected Reading (dBuV/m)	Avg Limit (dBuV/m)	Margin (dB)	Peak Limit (dBuV/m)	PK Margin (dB)	UNII Non-Restricted (dBuV/m)	PK Margin (dB)	Azimuth (Degs)	Height (cm)	Polarity
* 10.64	42.75	PK1	38.1	-25.2	0	55.65	-	-	74	-18.35	-	-	207	100	V
* 10.64	37.92	AD1	38.1	-25.2	:32	51.12	54	-2.88	-	-	-	-	207	100	V

* - indicates frequency in CFR15.205/IC7.2.2 Restricted Band

PK1 - KDB789033 Method: Peak

AD1 - KDB789033 Method: AD Primary Power Average

11.2.2. TX ABOVE 1 GHz 802.11n HT20 MODE IN THE 5.3 GHz BAND

AUTHORIZED BANDEDGE (HIGH CHANNEL)

HORIZONTAL PEAK AND AVERAGE PLOT

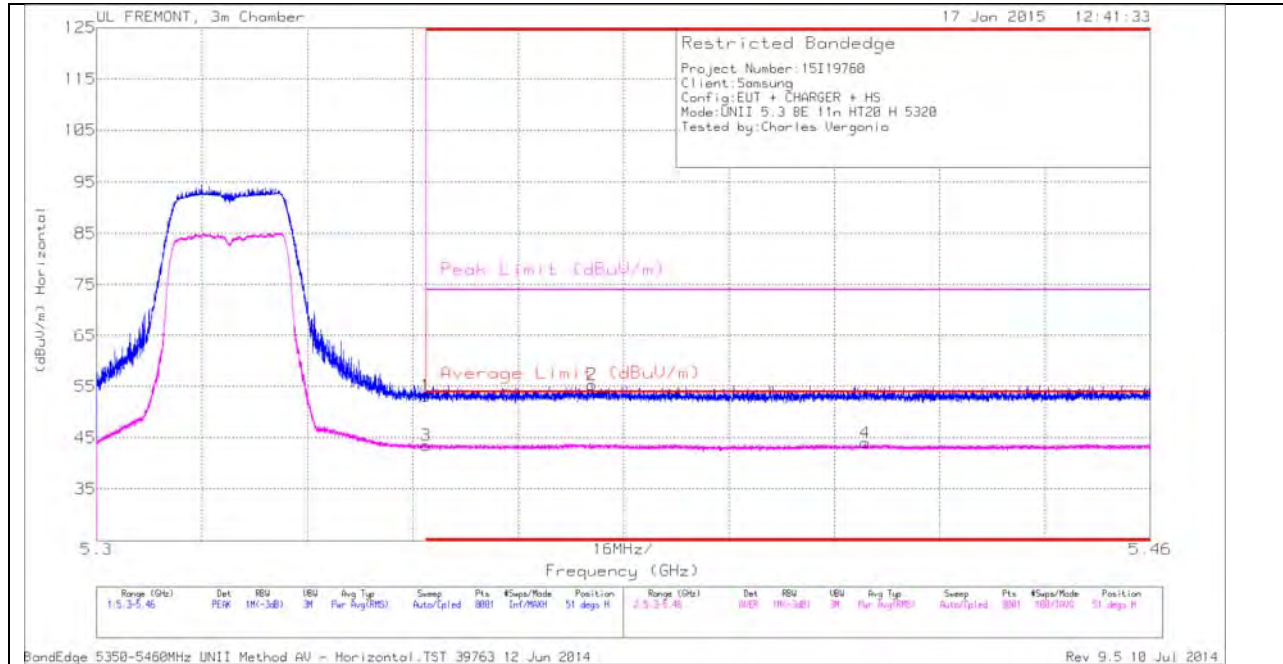

HORIZONTAL DATA

Marker	Frequency (GHz)	Meter Reading (dBuV)	Det	AF T711 (dB/m)	Amp/Cb/Flt r/Pad (dB)	DC Corr (dB)	Corrected Reading (dBuV/m)	Average Limit (dBuV/m)	Margin (dB)	Peak Limit (dBuV/m)	PK Margin (dB)	Azimuth (Degs)	Height (cm)	Polarity
1	* 5.35	40.24	PK	34.3	-21.4	0	53.14	-	-	74	-20.86	51	205	H
3	* 5.35	30.28	RMS	34.3	-21.4	.33	43.48	54	-10.52	-	-	51	205	H
2	* 5.375	42.42	PK	34.3	-21.4	0	55.32	-	-	74	-18.68	51	205	H
4	* 5.417	30.68	RMS	34.4	-21.4	.33	43.98	54	-10.02	-	-	51	205	H

VERTICAL PEAK AND AVERAGE PLOT

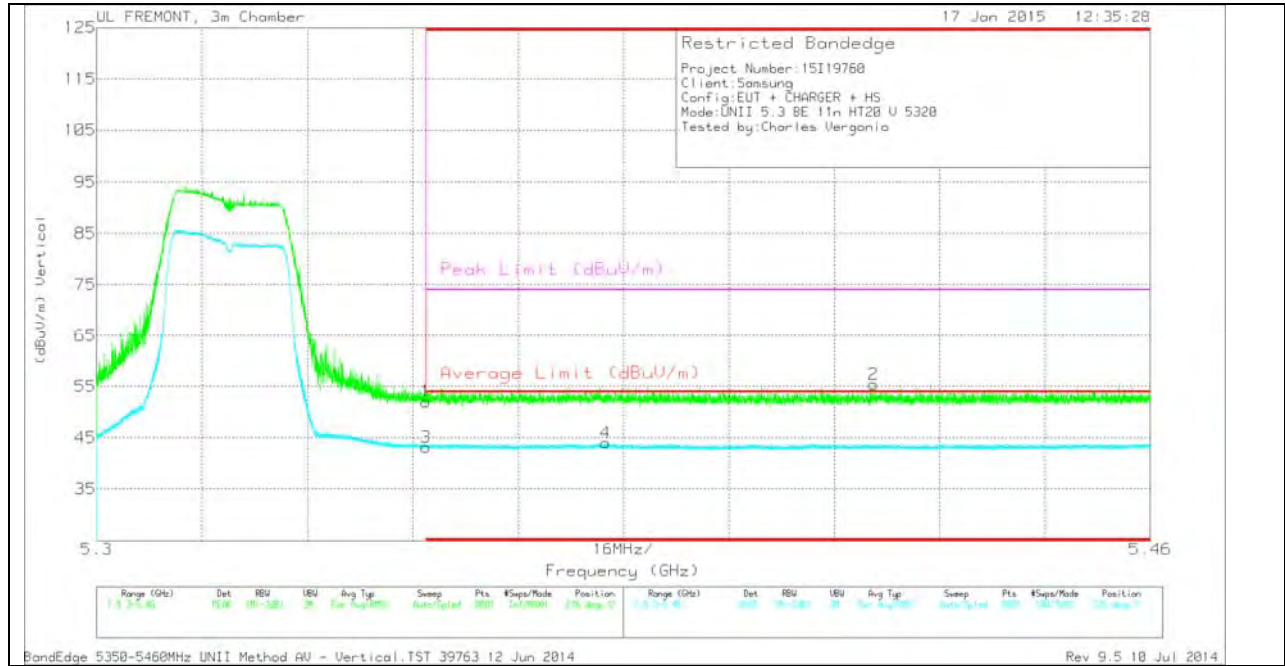

VERTICAL DATA

Marker	Frequency (GHz)	Meter Reading (dBuV)	Det	AF T711 (dB/m)	Amp/Cb/Fit r/Pad (dB)	DC Corr (dB)	Corrected Reading (dBuV/m)	Average Limit (dBuV/m)	Margin (dB)	Peak Limit (dBuV/m)	PK Margin (dB)	Azimuth (Degs)	Height (cm)	Polarity
1	* 5.35	39.13	PK	34.3	-21.4	0	52.03	-	-	74	-21.97	276	196	V
3	* 5.35	29.9	RMS	34.3	-21.4	.33	43.11	54	-10.89	-	-	276	196	V
4	* 5.377	30.7	RMS	34.3	-21.3	.33	44.01	54	-9.99	-	-	276	196	V
2	* 5.418	42.39	PK	34.4	-21.4	0	55.39	-	-	74	-18.61	276	196	V

HARMONICS AND SPURIOUS EMISSIONS

LOW CHANNEL HORIZONTAL

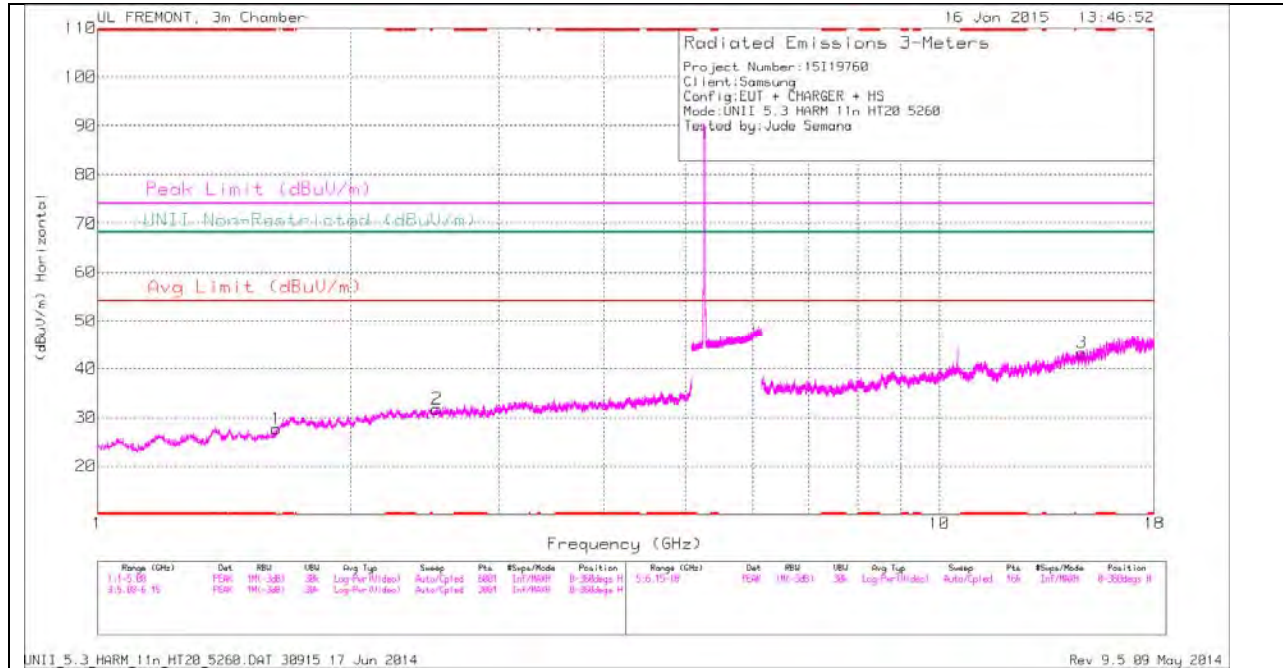

Note: Emission was scanned up to 40GHz; No emissions were detected above the noise floor which was at least 20dB below the specification limit.

LOW CHANNEL VERTICAL

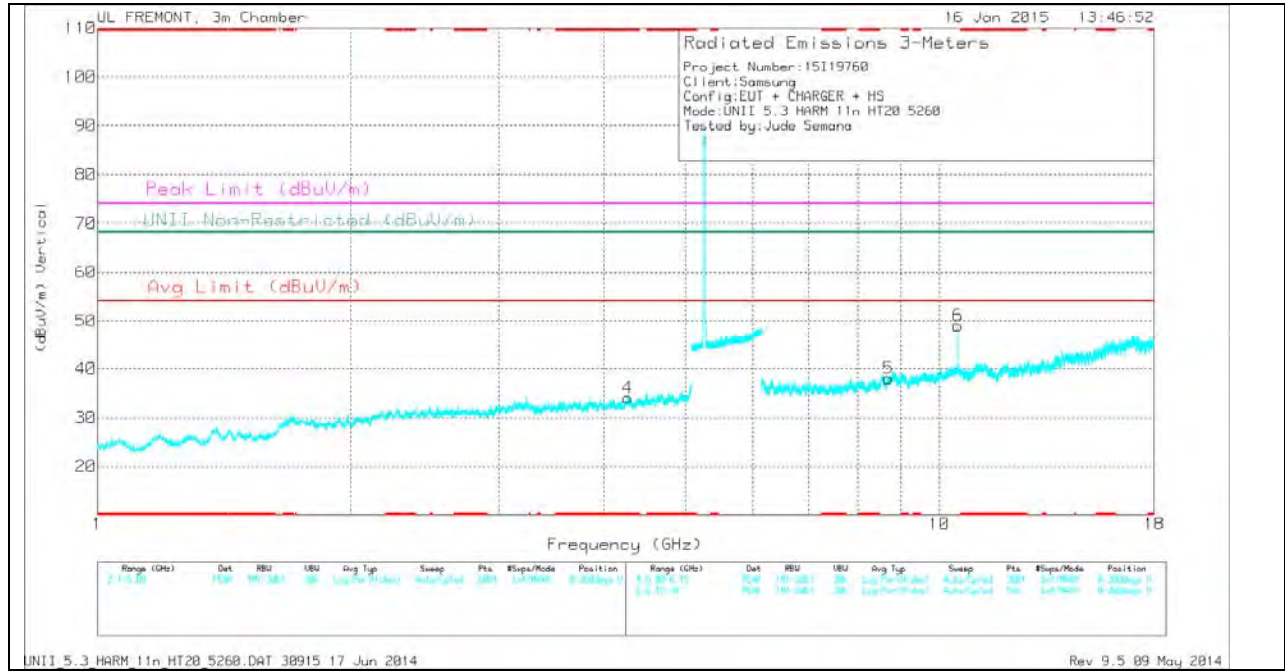

Note: Emission was scanned up to 40GHz; No emissions were detected above the noise floor which was at least 20dB below the specification limit.

LOW CHANNEL DATA

TRACE MARKERS

Marker	Frequency (GHz)	Meter Reading (dBuV)	Det	AF T711 (dB/m)	Amp/Cbl/Ftr/Pad (dB)	DC Corr (dB)	Corrected Reading (dBuV/m)	Avg Limit (dBuV/m)	Margin (dB)	Peak Limit (dBuV/m)	PK Margin (dB)	UNII Non-Restricted (dBuV/m)	PK Margin (dB)	Azimuth (Degs)	Height (cm)	Polarity
4	* 4.268	30.96	PK	33.4	-30.3	0	34.06	-	-	74	-39.94	-	-	0-360	200	V
1	1.632	31.89	PK	28.7	-32.9	0	27.69	-	-	-	-	68.2	-40.51	0-360	200	H
2	2.533	31.64	PK	32.2	-32.1	0	31.74	-	-	-	-	68.2	-36.46	0-360	100	H
5	8.698	29.43	PK	36.5	-27.9	0	38.03	-	-	-	-	68.2	-30.17	0-360	200	V
6	10.52	35.95	PK	38.1	-25	0	49.05	-	-	-	-	68.2	-19.15	0-360	100	V
3	14.768	30.73	PK	40.1	-27.5	0	43.33	-	-	-	-	68.2	-24.87	0-360	200	H

* - indicates frequency in CFR15.205/IC7.2.2 Restricted Band

PK - Peak detector

Radiated Emissions

Frequency (GHz)	Meter Reading (dBuV)	Det	AF T711 (dB/m)	Amp/Cbl/Ftr/Pad (dB)	DC Corr (dB)	Corrected Reading (dBuV/m)	Avg Limit (dBuV/m)	Margin (dB)	Peak Limit (dBuV/m)	PK Margin (dB)	UNII Non-Restricted (dBuV/m)	PK Margin (dB)	Azimuth (Degs)	Height (cm)	Polarity
10.52	41.01	PK1	38.1	-25	0	54.11	-	-	-	-	68.2	-14.09	210	100	V
10.52	34.87	AD1	38.1	-25	.33	48.27	-	-	-	-	-	-	210	100	V

* - indicates frequency in CFR15.205/IC7.2.2 Restricted Band

PK1 - KDB789033 Method: Peak

AD1 - KDB789033 Method: AD Primary Power Average

MID CHANNEL HORIZONTAL

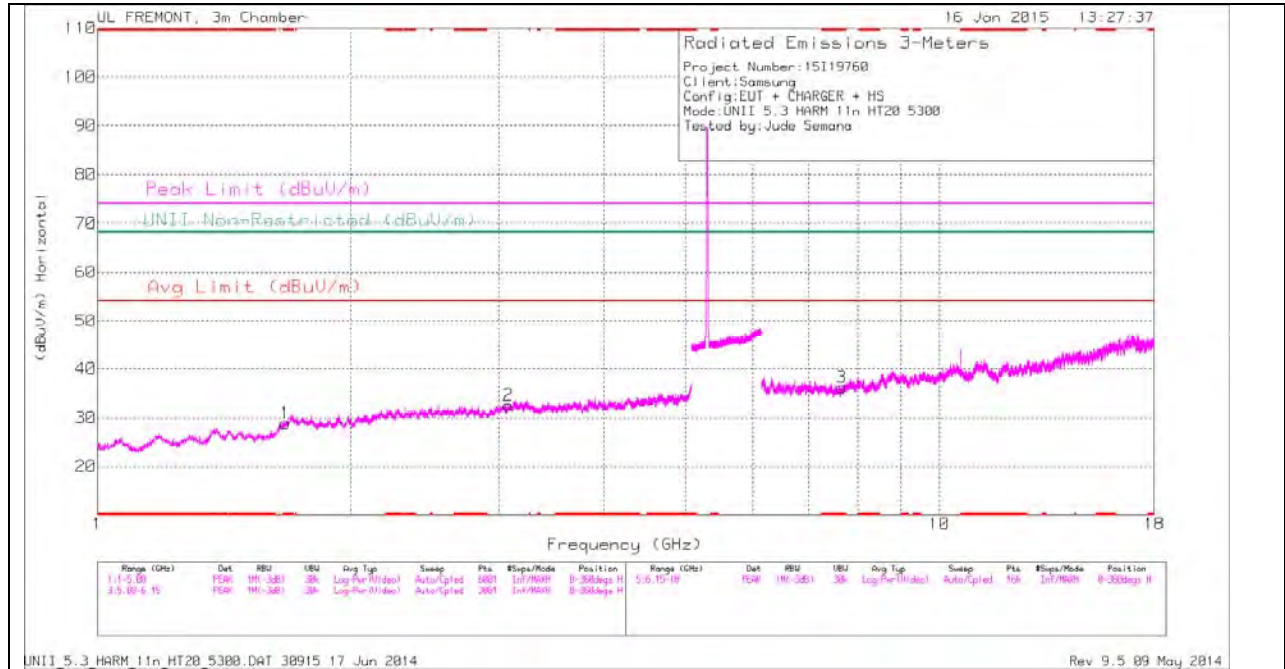

Note: Emission was scanned up to 40GHz; No emissions were detected above the noise floor which was at least 20dB below the specification limit.

MID CHANNEL VERTICAL

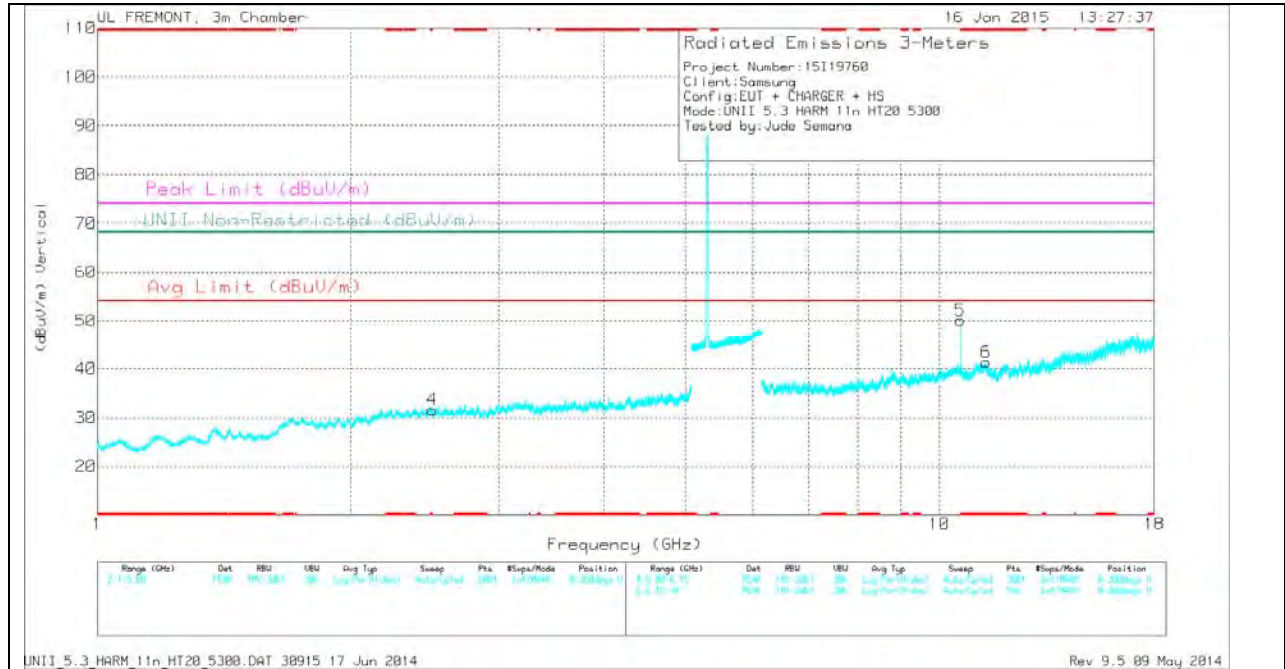

Note: Emission was scanned up to 40GHz; No emissions were detected above the noise floor which was at least 20dB below the specification limit.

MID CHANNEL DATA

TRACE MARKERS

Marker	Frequency (GHz)	Meter Reading (dBuV)	Det	AF T711 (dB/m)	Amp/Cbl/Ftr/Pad (dB)	DC Corr (dB)	Corrected Reading (dBuV/m)	Avg Limit (dBuV/m)	Margin (dB)	Peak Limit (dBuV/m)	PK Margin (dB)	UNII Non-Restricted (dBuV/m)	PK Margin (dB)	Azimuth (Degs)	Height (cm)	Polarity
1	* 1.672	31.44	PK	29.9	-32.5	0	28.84	-	-	74	-45.16	-	-	0-360	100	H
3	* 7.661	29.09	PK	35.7	-28.6	0	36.19	-	-	74	-37.81	-	-	0-360	200	H
5	* 10.6	37.29	PK	38.1	-25.3	0	50.09	-	-	74	-23.91	-	-	0-360	100	V
6	* 11.37	29.14	PK	38.2	-26	0	41.34	-	-	74	-32.66	-	-	0-360	100	V
4	2.501	31.52	PK	32.1	-32	0	31.62	-	-	-	-	68.2	-36.58	0-360	100	V
2	3.08	31.84	PK	32.9	-32.2	0	32.54	-	-	-	-	68.2	-35.66	0-360	200	H

* - indicates frequency in CFR15.205/IC7.2.2 Restricted Band

PK - Peak detector

Radiated Emissions

Frequency (GHz)	Meter Reading (dBuV)	Det	AF T711 (dB/m)	Amp/Cbl/Ftr/Pad (dB)	DC Corr (dB)	Corrected Reading (dBuV/m)	Avg Limit (dBuV/m)	Margin (dB)	Peak Limit (dBuV/m)	PK Margin (dB)	UNII Non-Restricted (dBuV/m)	PK Margin (dB)	Azimuth (Degs)	Height (cm)	Polarity
* 10.6	41.97	PK1	38.1	-25.3	0	54.77	-	-	74	-19.23	-	-	215	247	V
* 10.6	36.52	AD1	38.1	-25.3	.33	49.62	54	-4.38	-	-	-	-	215	247	V

* - indicates frequency in CFR15.205/IC7.2.2 Restricted Band

PK1 - KDB789033 Method: Peak

AD1 - KDB789033 Method: AD Primary Power Average

HIGH CHANNEL HORIZONTAL

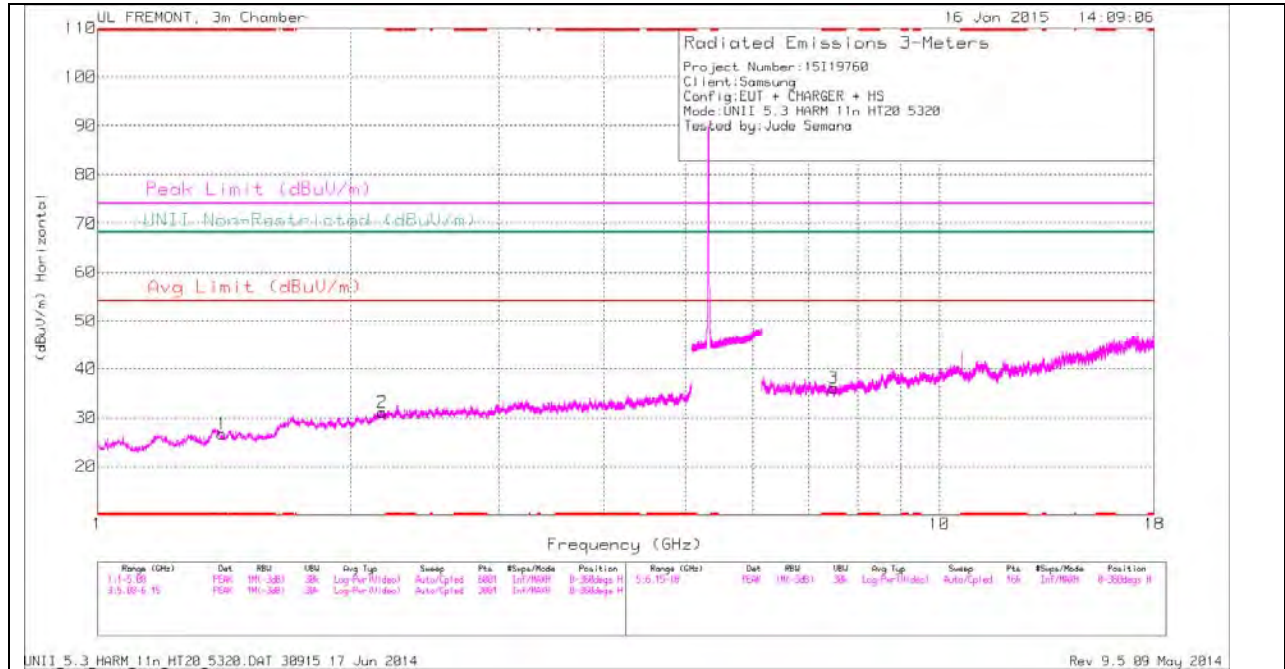

Note: Emission was scanned up to 40GHz; No emissions were detected above the noise floor which was at least 20dB below the specification limit.

HIGH CHANNEL VERTICAL

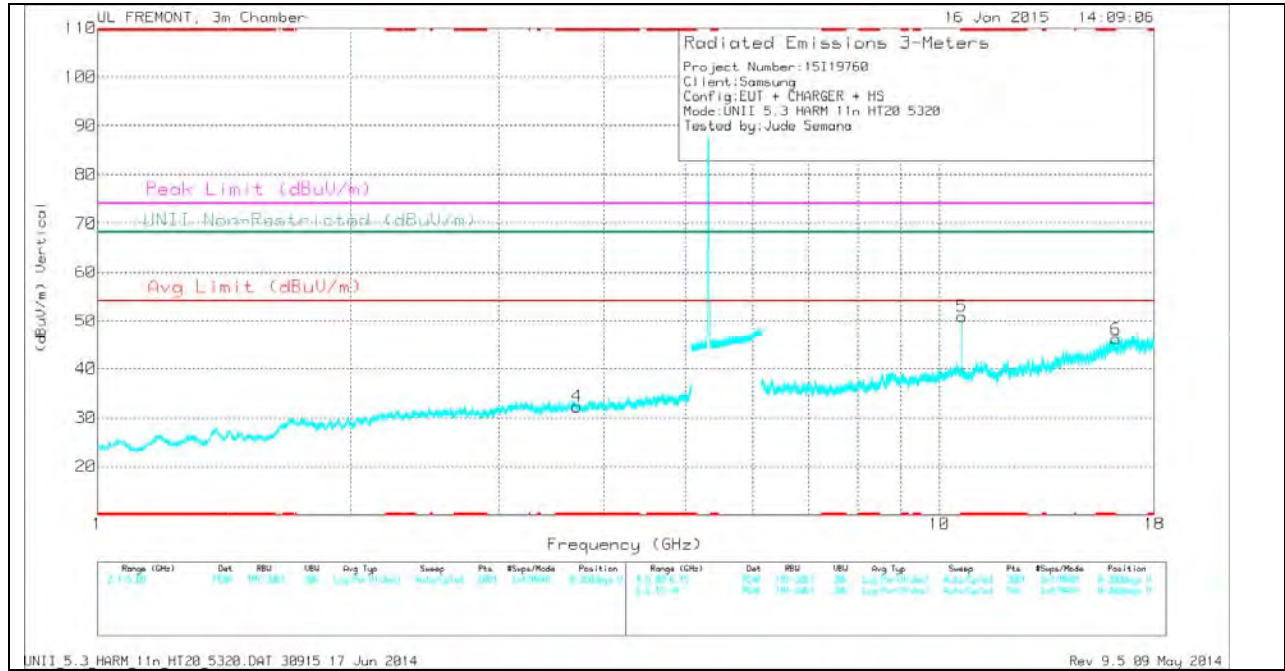

Note: Emission was scanned up to 40GHz; No emissions were detected above the noise floor which was at least 20dB below the specification limit.

HIGH CHANNEL DATA

TRACE MARKERS

Marker	Frequency (GHz)	Meter Reading (dBuV)	Det	AF T711 (dB/m)	Amp/Cbl/Ftr/Pad (dB)	DC Corr (dB)	Corrected Reading (dBuV/m)	Avg Limit (dBuV/m)	Margin (dB)	Peak Limit (dBuV/m)	PK Margin (dB)	UNII Non-Restricted (dBuV/m)	PK Margin (dB)	Azimuth (Degs)	Height (cm)	Polarity
1	* 1.407	31.22	PK	28.4	-32.9	0	26.72	-	-	74	-47.28	-	-	0-360	100	H
4	* 3.715	30.49	PK	32.9	-31.1	0	32.29	-	-	74	-41.71	-	-	0-360	200	V
3	* 7.489	29.36	PK	35.5	-28.8	0	36.06	-	-	74	-37.94	-	-	0-360	200	H
5	* 10.64	38.02	PK	38.1	-25.2	0	50.92	-	-	74	-23.08	-	-	0-360	100	V
2	2.181	31.89	PK	31.9	-32.7	0	31.09	-	-	-	-	68.2	-37.11	0-360	100	H
6	16.226	29.88	PK	41.8	-25.5	0	46.18	-	-	-	-	68.2	-22.02	0-360	200	V

* - indicates frequency in CFR15.205/IC7.2.2 Restricted Band

PK - Peak detector

Radiated Emissions

Frequency (GHz)	Meter Reading (dBuV)	Det	AF T711 (dB/m)	Amp/Cbl/Ftr/Pad (dB)	DC Corr (dB)	Corrected Reading (dBuV/m)	Avg Limit (dBuV/m)	Margin (dB)	Peak Limit (dBuV/m)	PK Margin (dB)	UNII Non-Restricted (dBuV/m)	PK Margin (dB)	Azimuth (Degs)	Height (cm)	Polarity
* 10.64	42.47	PK1	38.1	-25.1	0	55.47	-	-	74	-18.53	-	-	209	100	V
* 10.64	38.02	AD1	38.1	-25.2	.33	51.22	54	-2.78	-	-	-	-	209	100	V

* - indicates frequency in CFR15.205/IC7.2.2 Restricted Band

PK1 - KDB789033 Method: Peak

AD1 - KDB789033 Method: AD Primary Power Average

**11.2.3. TX ABOVE 1 GHz 802.11n HT40 MODE IN THE 5.3 GHz BAND
 AUTHORIZED BANDEDGE (HIGH CHANNEL)**

HORIZONTAL PEAK AND AVERAGE PLOT

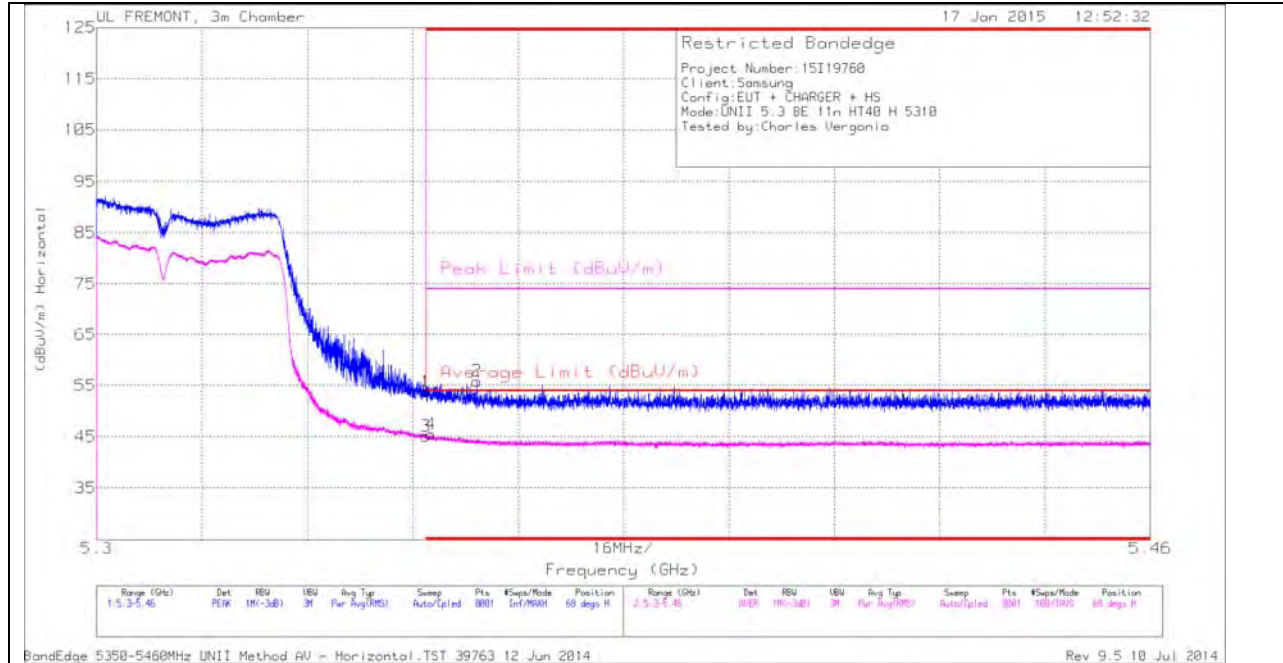

HORIZONTAL DATA

Marker	Frequency (GHz)	Meter Reading (dBuV)	Det	AF T711 (dB/m)	Amp/Cbl/Filter/Pad (dB)	DC Corr (dB)	Corrected Reading (dBuV/m)	Average Limit (dBuV/m)	Margin (dB)	Peak Limit (dBuV/m)	PK Margin (dB)	Azimuth (Degs)	Height (cm)	Polarity
1	* 5.35	40.91	PK	34.3	-21.4	0	53.81	-	-	74	-20.19	68	100	H
3	* 5.35	31.53	RMS	34.3	-21.4	.64	45.07	54	-8.93	-	-	68	100	H
4	* 5.351	31.91	RMS	34.3	-21.4	.64	45.45	54	-8.55	-	-	68	100	H
2	* 5.358	43.04	PK	34.3	-21.5	0	55.84	-	-	74	-18.16	68	100	H

VERTICAL PEAK AND AVERAGE PLOT

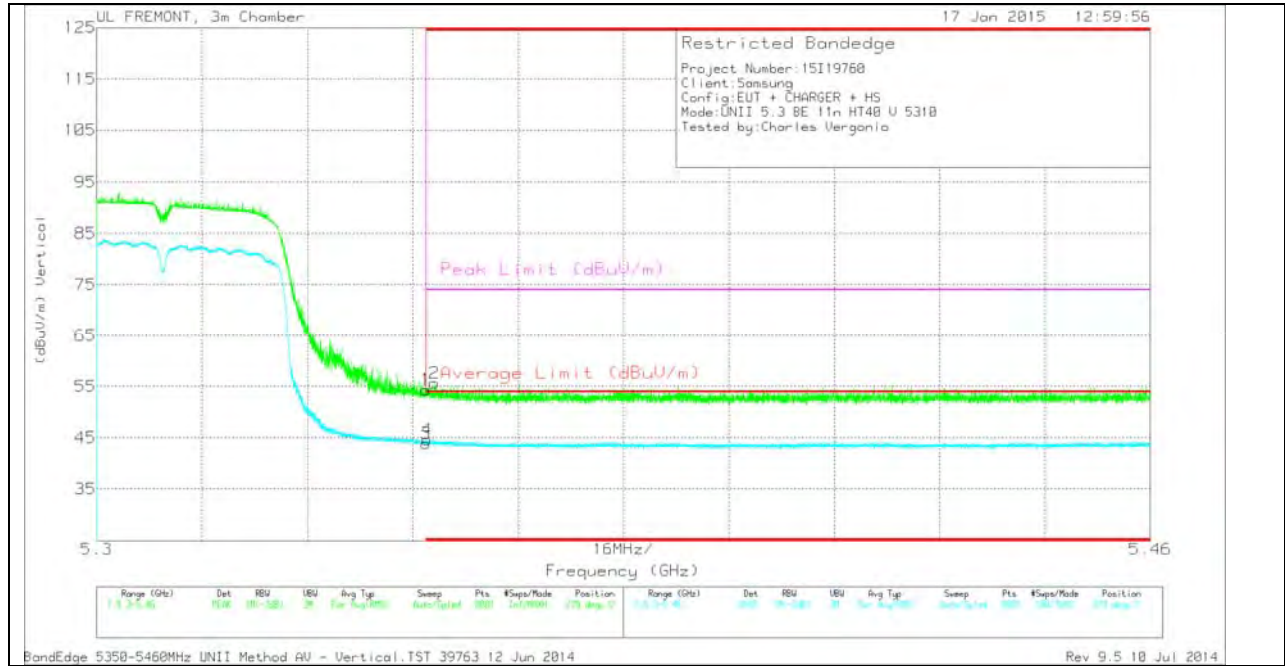

VERTICAL DATA

Marker	Frequency (GHz)	Meter Reading (dBuV)	Det	AF T711 (dB/m)	Amp/Cb/Fit r/Pad (dB)	DC Corr (dB)	Corrected Reading (dBuV/m)	Average Limit (dBuV/m)	Margin (dB)	Peak Limit (dBuV/m)	PK Margin (dB)	Azimuth (Degs)	Height (cm)	Polarity
1	* 5.35	41.44	PK	34.3	-21.4	0	54.34	-	-	74	-19.66	279	202	V
3	* 5.35	30.34	RMS	34.3	-21.4	.64	43.88	54	-10.12	-	-	279	202	V
4	* 5.35	31.05	RMS	34.3	-21.4	.64	44.59	54	-9.41	-	-	279	202	V
2	* 5.351	42.74	PK	34.3	-21.4	0	55.64	-	-	74	-18.36	279	202	V

HARMONICS AND SPURIOUS EMISSIONS

LOW CHANNEL HORIZONTAL

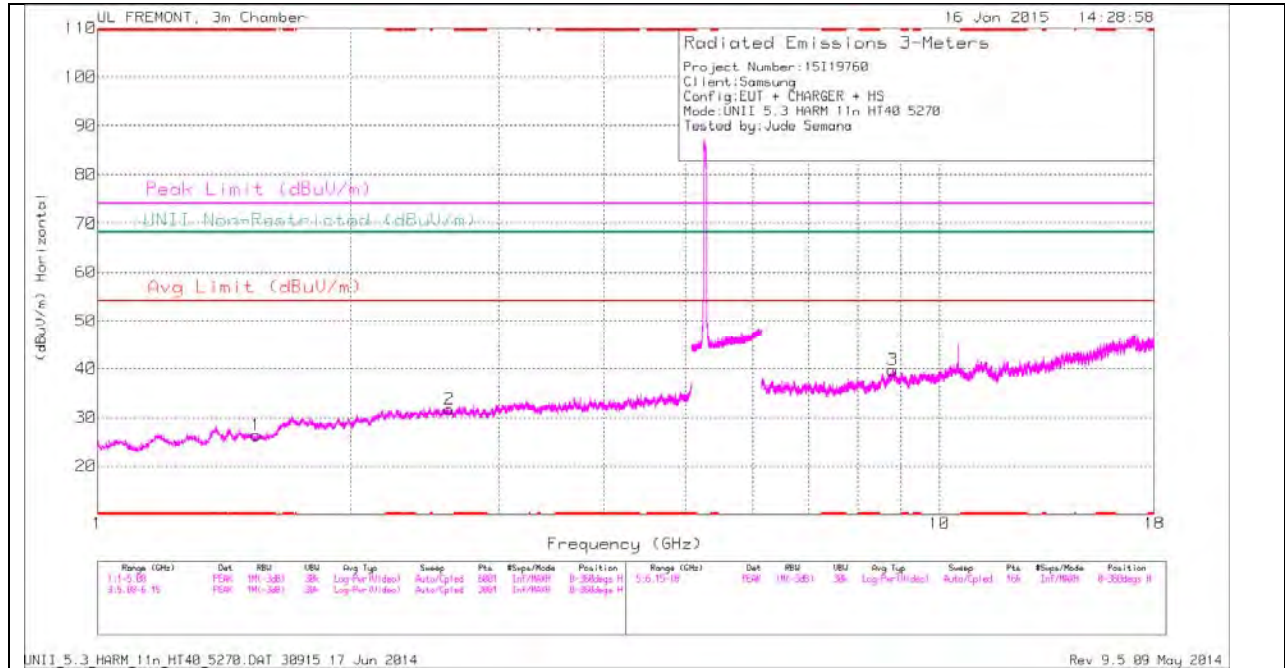

Note: Emission was scanned up to 40GHz; No emissions were detected above the noise floor which was at least 20dB below the specification limit.

LOW CHANNEL VERTICAL

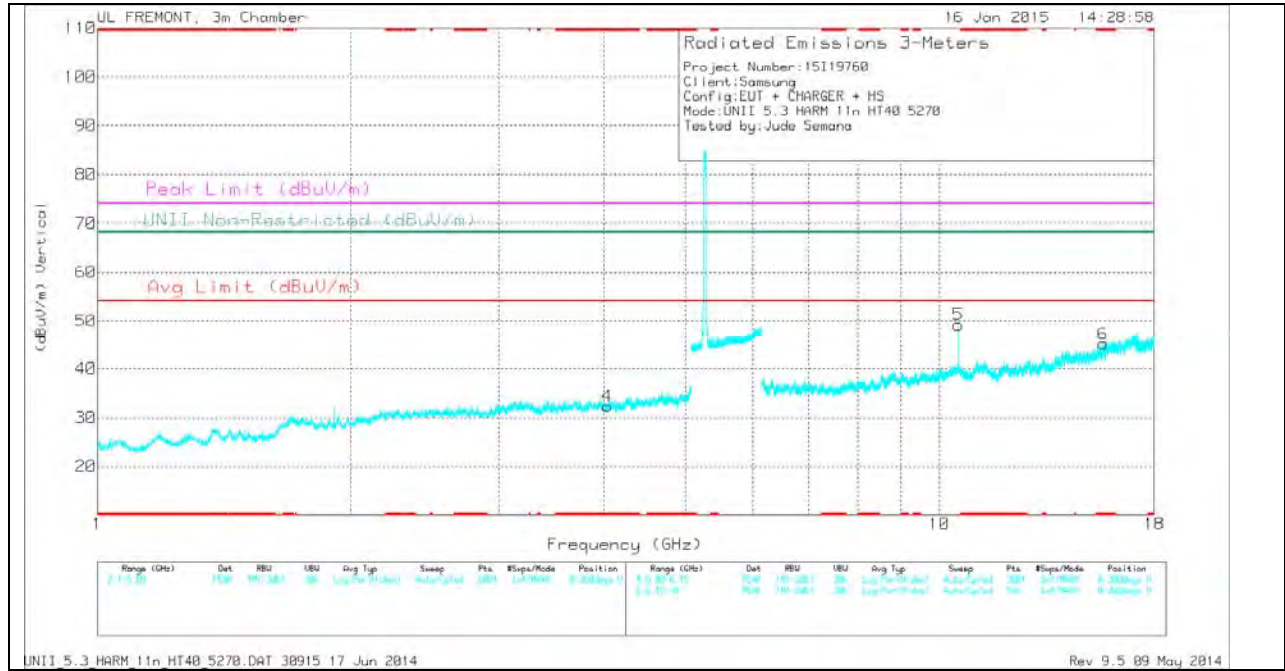

Note: Emission was scanned up to 40GHz; No emissions were detected above the noise floor which was at least 20dB below the specification limit.

LOW CHANNEL DATA

TRACE MARKERS

Marker	Frequency (GHz)	Meter Reading (dBuV)	Det	AF T711 (dB/m)	Amp/Cbl/Ftr/Pad (dB)	DC Corr (dB)	Corrected Reading (dBuV/m)	Avg Limit (dBuV/m)	Margin (dB)	Peak Limit (dBuV/m)	PK Margin (dB)	UNII Non-Restricted (dBuV/m)	PK Margin (dB)	Azimuth (Degs)	Height (cm)	Polarity
1	* 1.545	32.01	PK	27.7	-33.3	0	26.41	-	-	74	-47.59	-	-	0-360	200	H
4	* 4.036	30.63	PK	33.2	-31.5	0	32.33	-	-	74	-41.67	-	-	0-360	200	V
6	* 15.657	30.56	PK	41.3	-26.7	0	45.16	-	-	74	-28.84	-	-	0-360	200	V
2	2.62	31.82	PK	32.3	-32.4	0	31.72	-	-	-	-	68.2	-36.48	0-360	200	H
3	8.803	28.78	PK	36.6	-25.6	0	39.78	-	-	-	-	68.2	-28.42	0-360	200	H
5	10.539	36.4	PK	38.1	-25.3	0	49.2	-	-	-	-	68.2	-19	0-360	100	V

* - indicates frequency in CFR15.205/IC7.2.2 Restricted Band

PK - Peak detector

Radiated Emissions

Frequency (GHz)	Meter Reading (dBuV)	Det	AF T711 (dB/m)	Amp/Cbl/Ftr/Pad (dB)	DC Corr (dB)	Corrected Reading (dBuV/m)	Avg Limit (dBuV/m)	Margin (dB)	Peak Limit (dBuV/m)	PK Margin (dB)	UNII Non-Restricted (dBuV/m)	PK Margin (dB)	Azimuth (Degs)	Height (cm)	Polarity
10.54	41.41	PK1	38.1	-25.4	0	54.11	-	-	-	-	68.2	-14.09	209	108	V
10.54	36.18	AD1	38.1	-25.4	.64	49.48	-	-	-	-	-	-	209	108	V

* - indicates frequency in CFR15.205/IC7.2.2 Restricted Band

PK1 - KDB789033 Method: Peak

AD1 - KDB789033 Method: AD Primary Power Average

HIGH CHANNEL HORIZONTAL

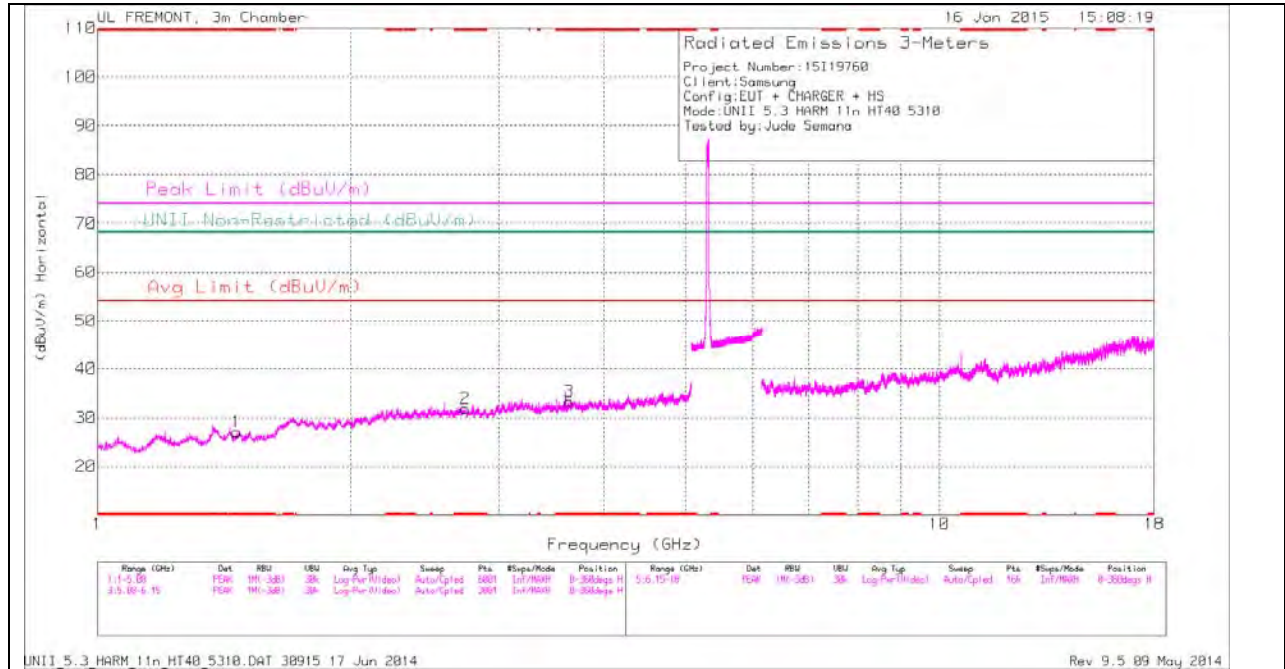

Note: Emission was scanned up to 40GHz; No emissions were detected above the noise floor which was at least 20dB below the specification limit.

HIGH CHANNEL VERTICAL

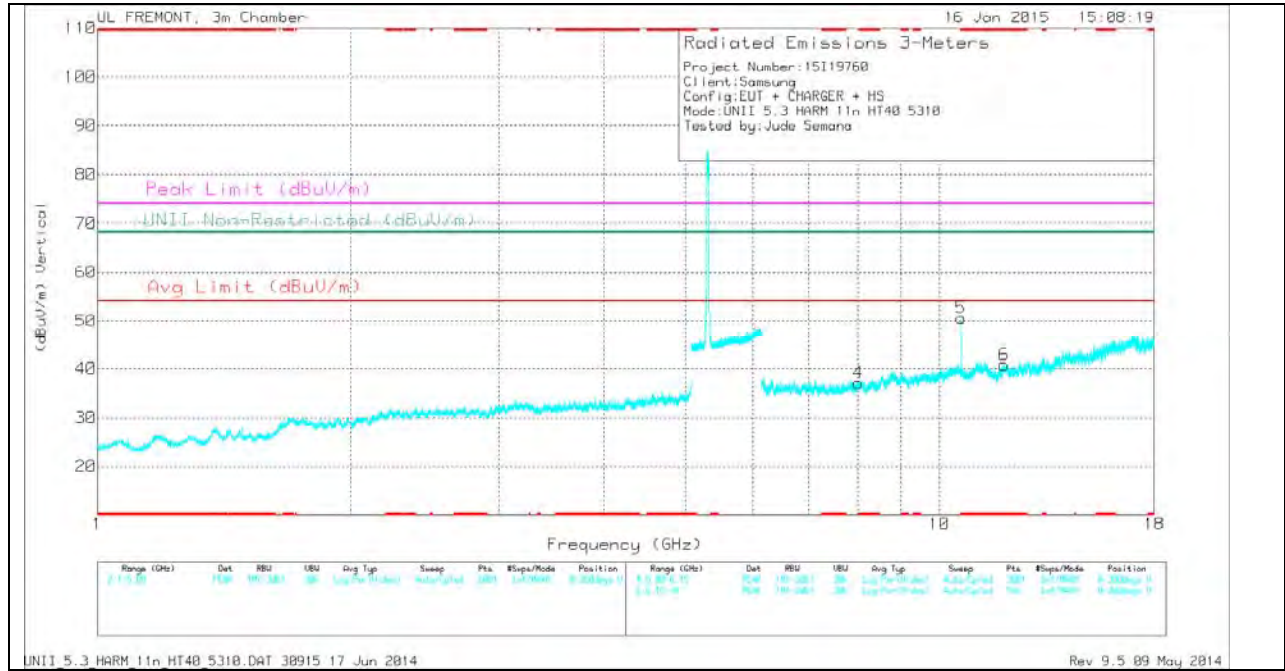

Note: Emission was scanned up to 40GHz; No emissions were detected above the noise floor which was at least 20dB below the specification limit.

HIGH CHANNEL DATA

TRACE MARKERS

Marker	Frequency (GHz)	Meter Reading (dBuV)	Det	AF T711 (dB/m)	Amp/Cbl/Ftr/Pad (dB)	DC Corr (dB)	Corrected Reading (dBuV/m)	Avg Limit (dBuV/m)	Margin (dB)	Peak Limit (dBuV/m)	PK Margin (dB)	UNII Non-Restricted (dBuV/m)	PK Margin (dB)	Azimuth (Degs)	Height (cm)	Polarity
1	* 1.464	32.06	PK	27.9	-32.9	0	27.06	-	-	74	-46.94	-	-	0-360	100	H
2	* 2.736	31.77	PK	32.4	-32.3	0	31.87	-	-	74	-42.13	-	-	0-360	200	H
3	* 3.635	31.38	PK	33.1	-31.2	0	33.28	-	-	74	-40.72	-	-	0-360	100	H
5	* 10.62	37.5	PK	38.1	-25	0	50.6	-	-	74	-23.4	-	-	0-360	100	V
6	* 11.938	28.74	PK	38.4	-26.3	0	40.84	-	-	74	-33.16	-	-	0-360	200	V
4	8.016	29.07	PK	35.9	-27.9	0	37.07	-	-	-	-	68.2	-31.13	0-360	200	V

* - indicates frequency in CFR15.205/IC7.2.2 Restricted Band

PK - Peak detector

Radiated Emissions

Frequency (GHz)	Meter Reading (dBuV)	Det	AF T711 (dB/m)	Amp/Cbl/Ftr/Pad (dB)	DC Corr (dB)	Corrected Reading (dBuV/m)	Avg Limit (dBuV/m)	Margin (dB)	Peak Limit (dBuV/m)	PK Margin (dB)	UNII Non-Restricted (dBuV/m)	PK Margin (dB)	Azimuth (Degs)	Height (cm)	Polarity
* 10.62	41.88	PK1	38.1	-25	0	54.98	-	-	74	-19.02	-	-	206	375	V
* 10.62	36.36	AD1	38.1	-25	.64	50.06	54	-3.94	-	-	-	-	206	375	V

* - indicates frequency in CFR15.205/IC7.2.2 Restricted Band

PK1 - KDB789033 Method: Peak

AD1 - KDB789033 Method: AD Primary Power Average

11.3. 5.5-5.6 GHz

11.3.1. TX ABOVE 1 GHz 802.11a MODE IN THE 5.5 GHz BAND

RESTRICTED BANDEDGE (LOW CHANNEL)

HORIZONTAL PEAK AND AVERAGE PLOT

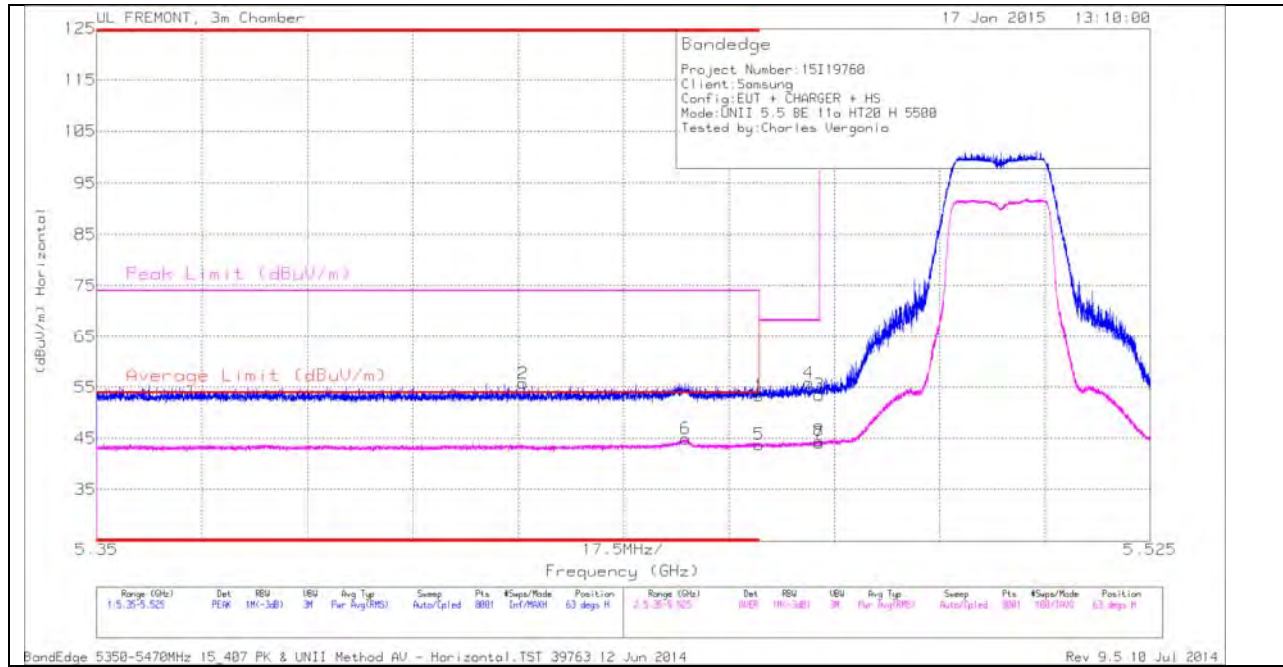

HORIZONTAL DATA

Marker	Frequency (GHz)	Meter Reading (dBuV)	Det	AF T711 (dB/m)	Amp/Cb/Fit r/Pad (dB)	DC Corr (dB)	Corrected Reading (dBuV/m)	Average Limit (dBuV/m)	Margin (dB)	Peak Limit (dBuV/m)	PK Margin (dB)	Azimuth (Degs)	Height (cm)	Polarity
2	* 5.421	42.74	PK	34.4	-21.4	0	55.74	-	-	74	-18.26	63	103	H
6	* 5.448	31.54	RMS	34.5	-21.4	.32	44.94	54	-9.06	-	-	63	103	H
1	* 5.46	40.2	PK	34.5	-21.4	0	53.3	-	-	74	-20.7	63	103	H
5	* 5.46	30.42	RMS	34.5	-21.4	.32	43.82	54	-10.18	-	-	63	103	H
4	5.468	42.66	PK	34.5	-21.3	0	55.86	-	-	68.2	-12.34	63	103	H
3	5.47	40.32	PK	34.5	-21.3	0	53.52	-	-	68.2	-14.68	63	103	H
7	5.47	30.6	RMS	34.5	-21.3	.32	44.1	-	-	-	-	63	103	H
8	5.47	31.05	RMS	34.5	-21.3	.32	44.55	-	-	-	-	63	103	H

VERTICAL PEAK AND AVERAGE PLOT

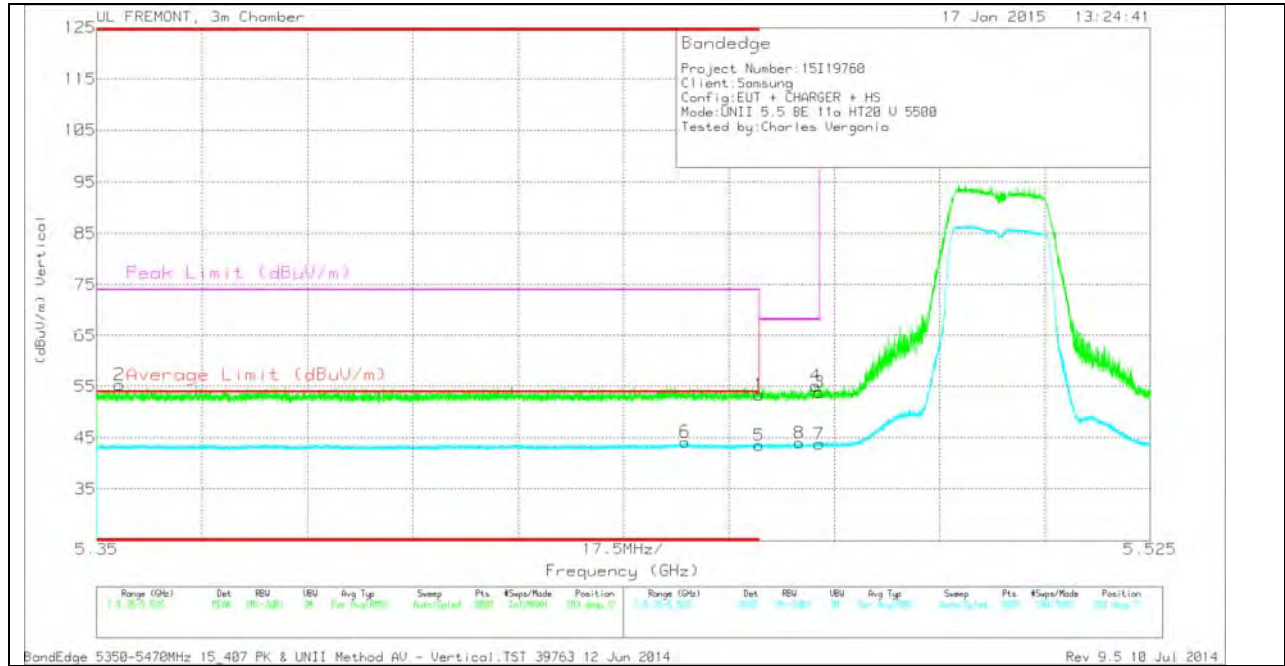

VERTICAL DATA

Marker	Frequency (GHz)	Meter Reading (dBuV)	Det	AF T711 (dB/m)	Amp/Cb/Fit r/Pad (dB)	DC Corr (dB)	Corrected Reading (dBuV/m)	Average Limit (dBuV/m)	Margin (dB)	Peak Limit (dBuV/m)	PK Margin (dB)	Azimuth (Degs)	Height (cm)	Polarity
2	* 5.354	42.43	PK	34.3	-21.4	0	55.33	-	-	74	-18.67	183	131	V
6	* 5.448	30.77	RMS	34.5	-21.4	.32	44.17	54	-9.83	-	-	183	131	V
1	* 5.46	40.3	PK	34.5	-21.4	0	53.4	-	-	74	-20.6	183	131	V
5	* 5.46	30.09	RMS	34.5	-21.4	.32	43.49	54	-10.51	-	-	183	131	V
8	5.467	30.49	RMS	34.5	-21.3	.32	43.99	-	-	-	-	183	131	V
4	5.469	41.92	PK	34.5	-21.3	0	55.12	-	-	68.2	-13.08	183	131	V
3	5.47	40.68	PK	34.5	-21.3	0	53.88	-	-	68.2	-14.32	183	131	V
7	5.47	30.26	RMS	34.5	-21.3	.32	43.76	-	-	-	-	183	131	V

AUTHORIZED BANDEDGE (HIGH CHANNEL)

HORIZONTAL PEAK PLOT

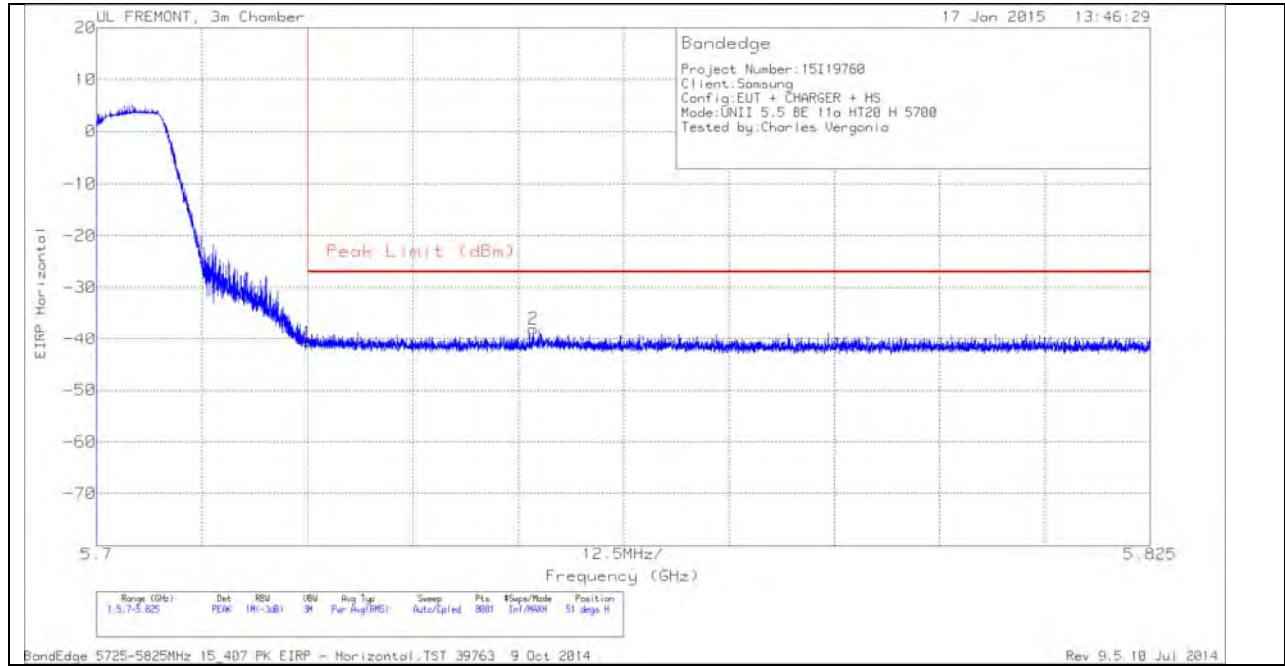

HORIZONTAL DATA

Marker	Frequency (GHz)	Meter Reading (dBm)	Det	AF T711 (dB/m)	Amp/Cbl/F ltr/Pad (dB)	Conversion Factor (dB)	Corrected Reading EIRP	Peak Limit (dBm)	PK Margin (dB)	Azimuth (Degs)	Height (cm)	Polarity
1	5.725	-66.48	PK	35.2	-21.1	11.8	-40.58	-27	-13.58	51	133	H
2	5.752	-63.99	PK	35.3	-21.1	11.8	-37.99	-27	-10.99	51	133	H

VERTICAL PEAK PLOT

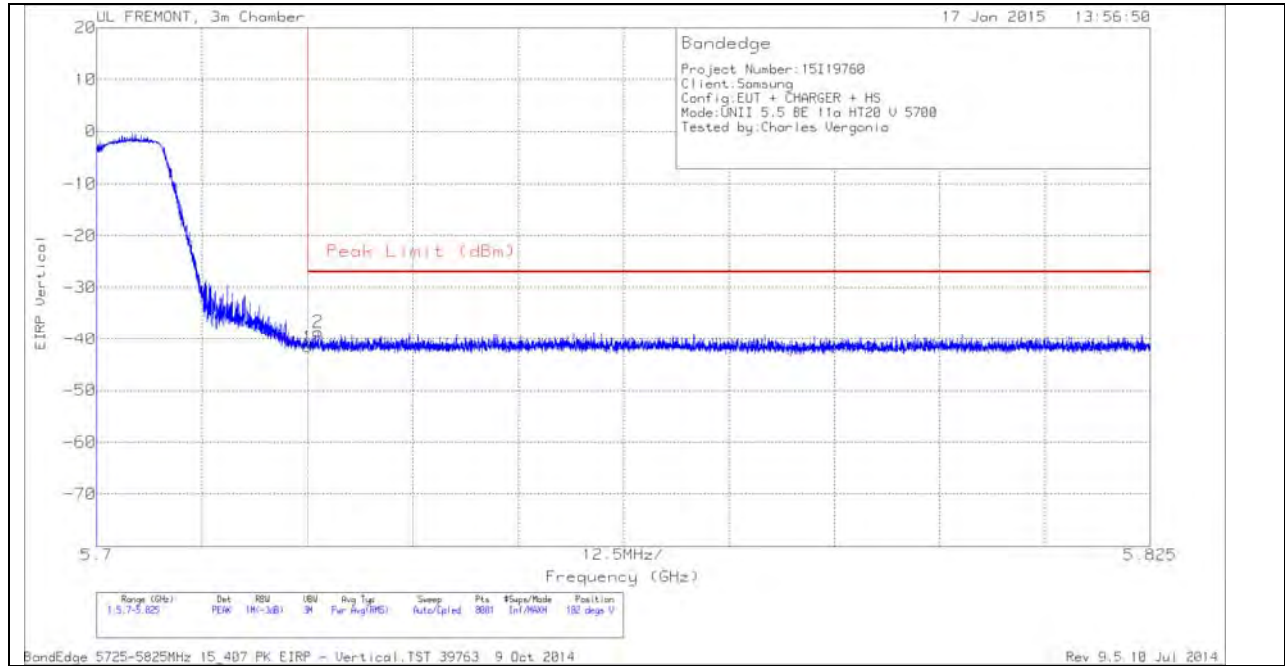

VERTICAL DATA

Marker	Frequency (GHz)	Meter Reading (dBm)	Det	AF T711 (dB/m)	Amp/Cbl/F ltr/Pad (dB)	Conversion Factor (dB)	Corrected Reading EIRP	Peak Limit (dBm)	PK Margin (dB)	Azimuth (Degs)	Height (cm)	Polarity
1	5.725	-67.47	PK	35.2	-21.1	11.8	-41.57	-27	-14.57	182	151	V
2	5.726	-64.5	PK	35.2	-21.1	11.8	-38.6	-27	-11.6	182	151	V

HARMONICS AND SPURIOUS EMISSIONS

LOW CHANNEL HORIZONTAL

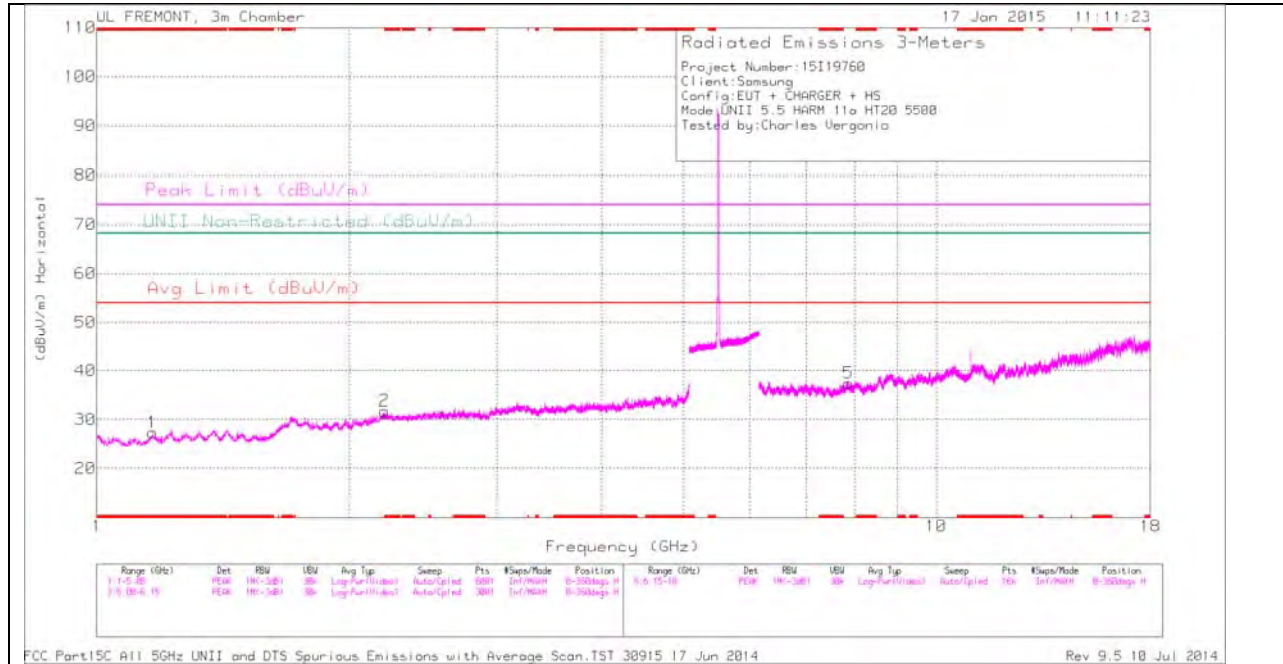

Note: Emission was scanned up to 40GHz; No emissions were detected above the noise floor which was at least 20dB below the specification limit.

LOW CHANNEL VERTICAL

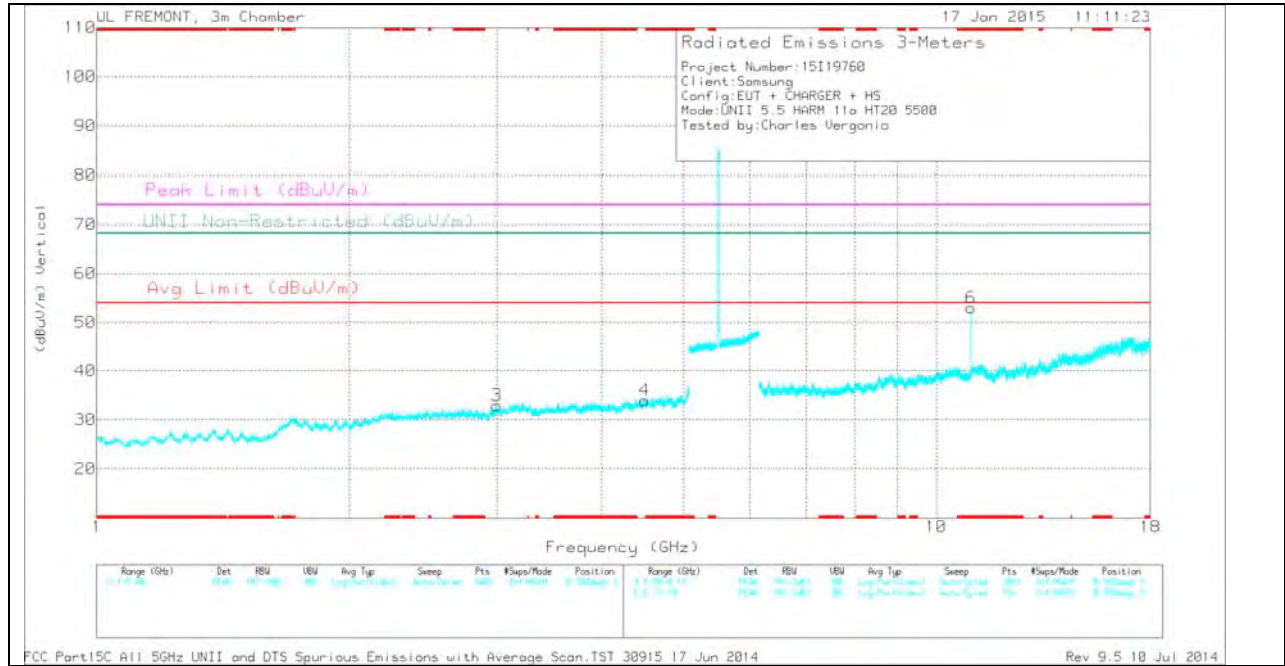

Note: Emission was scanned up to 40GHz; No emissions were detected above the noise floor which was at least 20dB below the specification limit.

LOW CHANNEL DATA

TRACE MARKERS

Marker	Frequency (GHz)	Meter Reading (dBuV)	Det	AF T711 (dB/m)	Amp/Cbl/Ftr/Pad (dB)	DC Corr (dB)	Corrected Reading (dBuV/m)	Avg Limit (dBuV/m)	Margin (dB)	Peak Limit (dBuV/m)	PK Margin (dB)	UNII Non-Restricted (dBuV/m)	PK Margin (dB)	Azimuth (Degs)	Height (cm)	Polarity
1	* 1.165	32.95	PK	27.6	-33.2	0	27.35	-	-	74	-46.65	-	-	0-360	100	H
2	* 2.2	32.36	PK	32	-32.6	0	31.76	-	-	74	-42.24	-	-	0-360	100	H
6	* 11	40.07	PK	38.3	-25.4	0	52.97	-	-	74	-21.03	-	-	0-360	100	V
3	2.995	32.02	PK	32.7	-31.8	0	32.92	-	-	-	-	68.2	-35.28	0-360	100	V
4	4.495	31.35	PK	33.6	-31	0	33.95	-	-	-	-	68.2	-34.25	0-360	100	V
5	7.863	29.12	PK	35.8	-27.5	0	37.42	-	-	-	-	68.2	-30.78	0-360	200	H

* - indicates frequency in CFR15.205/IC7.2.2 Restricted Band

PK - Peak detector

Radiated Emissions

Frequency (GHz)	Meter Reading (dBuV)	Det	AF T711 (dB/m)	Amp/Cbl/Ftr/Pad (dB)	DC Corr (dB)	Corrected Reading (dBuV/m)	Avg Limit (dBuV/m)	Margin (dB)	Peak Limit (dBuV/m)	PK Margin (dB)	UNII Non-Restricted (dBuV/m)	PK Margin (dB)	Azimuth (Degs)	Height (cm)	Polarity
* 11	44.56	PK1	38.3	-25.4	0	57.46	-	-	74	-16.54	-	-	25	107	V
* 11	40.39	AD1	38.3	-25.4	.32	53.59	54	-.41	-	-	-	-	25	107	V
* 11	44.36	PK1	38.3	-25.4	0	57.26	-	-	74	-16.74	-	-	24	101	V
* 11	40.4	AD1	38.3	-25.4	.32	53.6	54	-.4	-	-	-	-	24	101	V

* - indicates frequency in CFR15.205/IC7.2.2 Restricted Band

PK1 - KDB789033 Method: Peak

AD1 - KDB789033 Method: AD Primary Power Average

MID CHANNEL HORIZONTAL

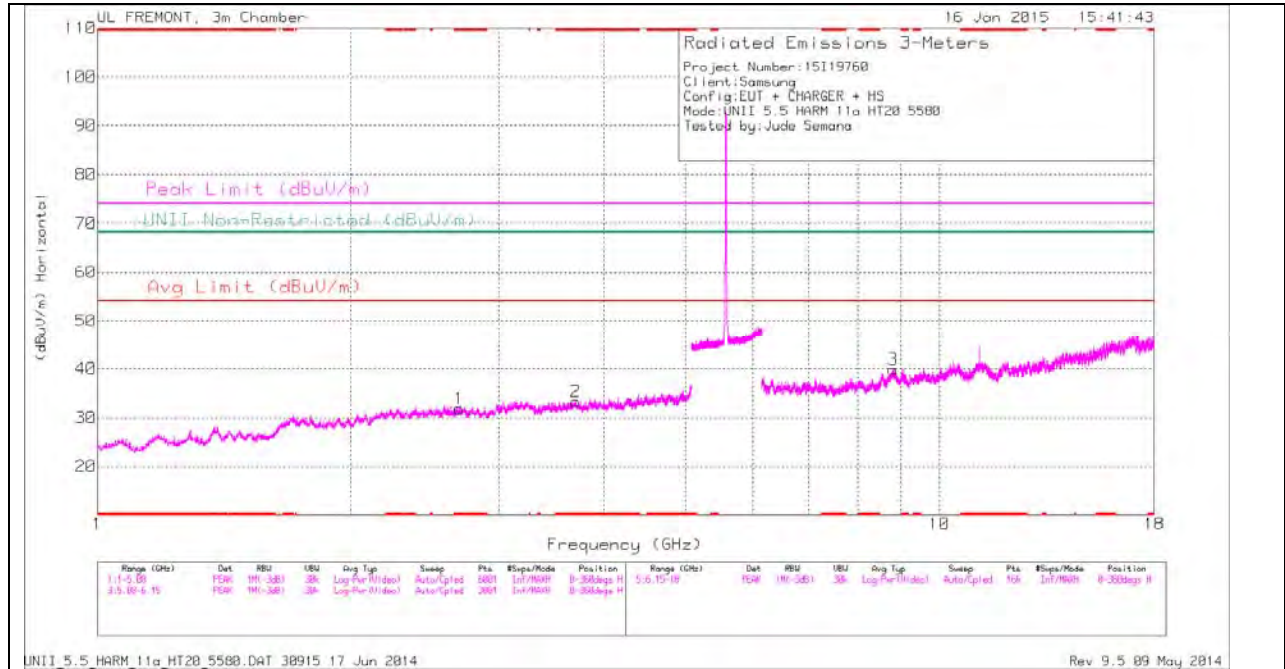

Note: Emission was scanned up to 40GHz; No emissions were detected above the noise floor which was at least 20dB below the specification limit.

MID CHANNEL VERTICAL

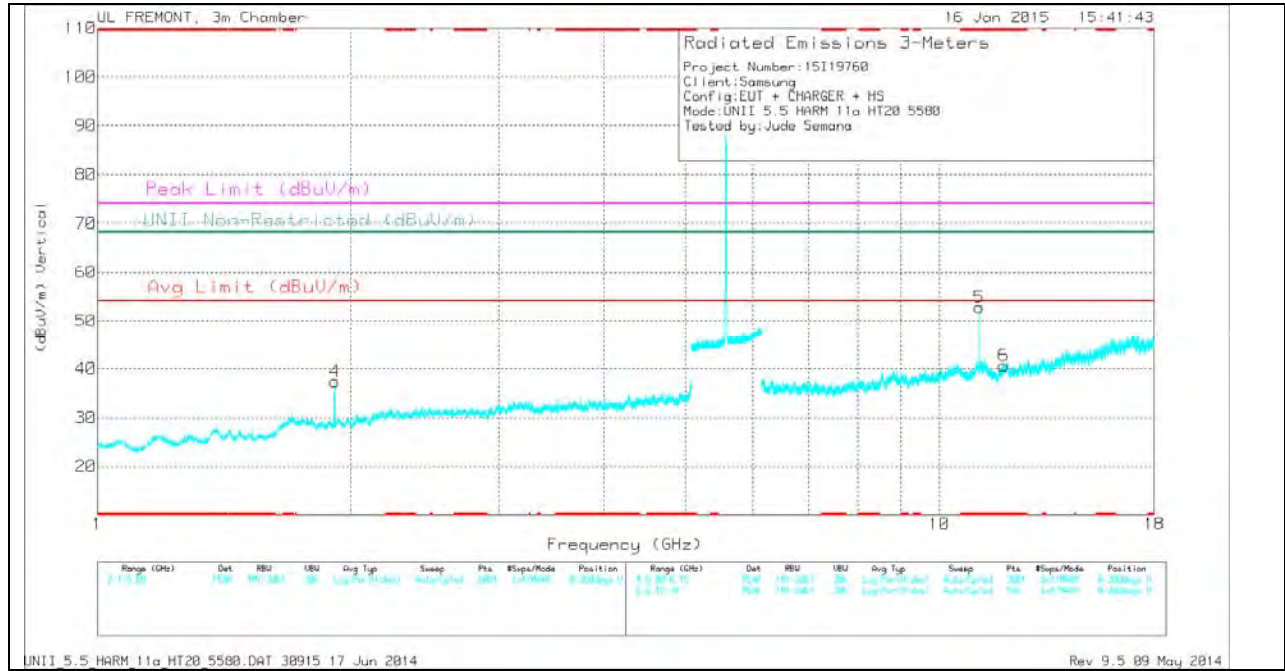

Note: Emission was scanned up to 40GHz; No emissions were detected above the noise floor which was at least 20dB below the specification limit.

MID CHANNEL DATA

TRACE MARKERS

Marker	Frequency (GHz)	Meter Reading (dBuV)	Det	AF T711 (dB/m)	Amp/Cbl/Ftr/Pad (dB)	DC Corr (dB)	Corrected Reading (dBuV/m)	Avg Limit (dBuV/m)	Margin (dB)	Peak Limit (dBuV/m)	PK Margin (dB)	UNII Non-Restricted (dBuV/m)	PK Margin (dB)	Azimuth (Degs)	Height (cm)	Polarity
1	* 2.69	31.71	PK	32.4	-32.3	0	31.81	-	-	74	-42.19	-	-	0-360	200	H
2	* 3.702	31.07	PK	32.9	-30.7	0	33.27	-	-	74	-40.73	-	-	0-360	200	H
5	* 11.16	40.31	PK	38.3	-25.8	0	52.81	-	-	74	-21.19	-	-	0-360	200	V
6	* 11.928	28.48	PK	38.4	-26.2	0	40.68	-	-	74	-33.32	-	-	0-360	100	V
4	1.915	39.98	PK	30.2	-32.8	0	37.38	-	-	-	-	68.2	-30.82	0-360	100	V
3	8.815	28.74	PK	36.6	-25.5	0	39.84	-	-	-	-	68.2	-28.36	0-360	200	H

* - indicates frequency in CFR15.205/IC7.2.2 Restricted Band

PK - Peak detector

Radiated Emissions

Frequency (GHz)	Meter Reading (dBuV)	Det	AF T711 (dB/m)	Amp/Cbl/Ftr/Pad (dB)	DC Corr (dB)	Corrected Reading (dBuV/m)	Avg Limit (dBuV/m)	Margin (dB)	Peak Limit (dBuV/m)	PK Margin (dB)	UNII Non-Restricted (dBuV/m)	PK Margin (dB)	Azimuth (Degs)	Height (cm)	Polarity
* 11.16	43.26	PK1	38.3	-25.8	0	55.76	-	-	74	-18.24	-	-	71	174	V
* 11.16	39.15	AD1	38.3	-25.8	.32	51.95	54	-2.05	-	-	-	-	71	174	V
* 11.57	43.74	PK1	38.1	-26.1	0	55.74	-	-	74	-18.26	-	-	52	319	V
* 11.57	39.33	AD1	38.1	-26.1	.32	51.63	54	-2.37	-	-	-	-	52	319	V

* - indicates frequency in CFR15.205/IC7.2.2 Restricted Band

PK1 - KDB789033 Method: Peak

AD1 - KDB789033 Method: AD Primary Power Average

HIGH CHANNEL HORIZONTAL

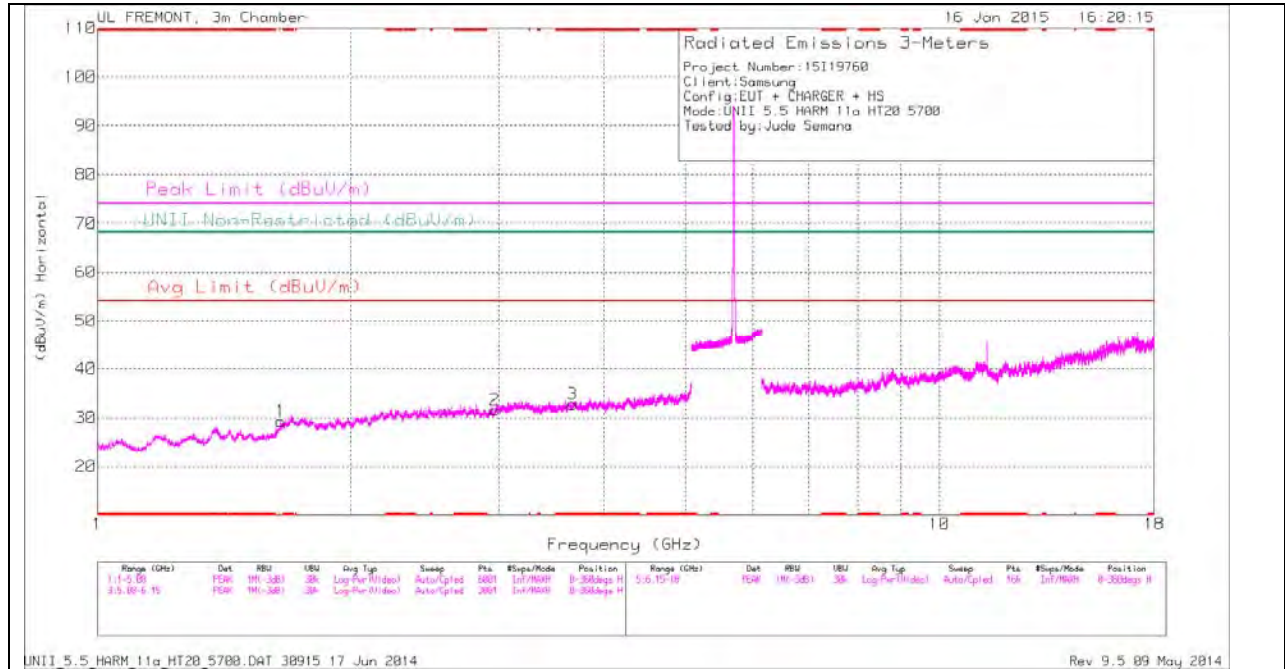

Note: Emission was scanned up to 40GHz; No emissions were detected above the noise floor which was at least 20dB below the specification limit.

HIGH CHANNEL VERTICAL

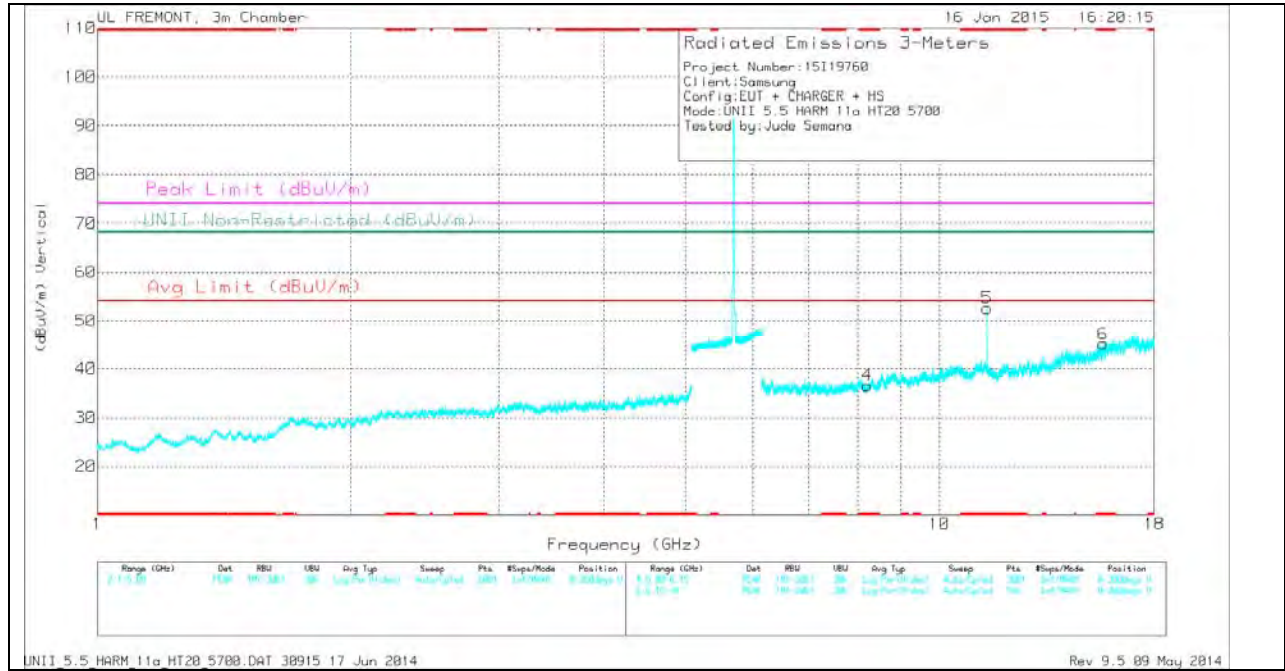

Note: Emission was scanned up to 40GHz; No emissions were detected above the noise floor which was at least 20dB below the specification limit.

HIGH CHANNEL DATA

TRACE MARKERS

Marker	Frequency (GHz)	Meter Reading (dBuV)	Det	AF T711 (dB/m)	Amp/Cbl/Ftr/Pad (dB)	DC Corr (dB)	Corrected Reading (dBuV/m)	Avg Limit (dBuV/m)	Margin (dB)	Peak Limit (dBuV/m)	PK Margin (dB)	UNII Non-Restricted (dBuV/m)	PK Margin (dB)	Azimuth (Degs)	Height (cm)	Polarity
3	* 3.67	30.36	PK	33	-30.6	0	32.76	-	-	74	-41.24	-	-	0-360	200	H
4	* 8.21	29.29	PK	36.1	-28.8	0	36.59	-	-	74	-37.41	-	-	0-360	100	V
5	* 11.4	40.41	PK	38.2	-26	0	52.61	-	-	74	-21.39	-	-	0-360	100	V
6	* 15.658	30.56	PK	41.3	-26.7	0	45.16	-	-	74	-28.84	-	-	0-360	100	V
1	1.651	32.75	PK	29.2	-32.7	0	29.25	-	-	-	-	68.2	-38.95	0-360	100	H
2	2.967	31.27	PK	32.4	-32.1	0	31.57	-	-	-	-	68.2	-36.63	0-360	100	H

* - indicates frequency in CFR15.205/IC7.2.2 Restricted Band

PK - Peak detector

Radiated Emissions

Frequency (GHz)	Meter Reading (dBuV)	Det	AF T711 (dB/m)	Amp/Cbl/Ftr/Pad (dB)	DC Corr (dB)	Corrected Reading (dBuV/m)	Avg Limit (dBuV/m)	Margin (dB)	Peak Limit (dBuV/m)	PK Margin (dB)	UNII Non-Restricted (dBuV/m)	PK Margin (dB)	Azimuth (Degs)	Height (cm)	Polarity
* 11.4	43.02	PK1	38.2	-26	0	55.22	-	-	74	-18.78	-	-	48	110	V
* 11.4	38.72	AD1	38.2	-26	.32	51.22	54	-2.78	-	-	-	-	48	110	V
* 11.57	43.74	PK1	38.1	-26.1	0	55.74	-	-	74	-18.26	-	-	52	319	V
* 11.57	39.33	AD1	38.1	-26.1	.32	51.63	54	-2.37	-	-	-	-	52	319	V

* - indicates frequency in CFR15.205/IC7.2.2 Restricted Band

PK1 - KDB789033 Method: Peak

AD1 - KDB789033 Method: AD Primary Power Average

**11.3.2. TX ABOVE 1 GHz 802.11n HT20 MODE IN THE 5.5 GHz BAND
 RESTRICTED BANDEDGE (LOW CHANNEL)**

HORIZONTAL PEAK AND AVERAGE PLOT

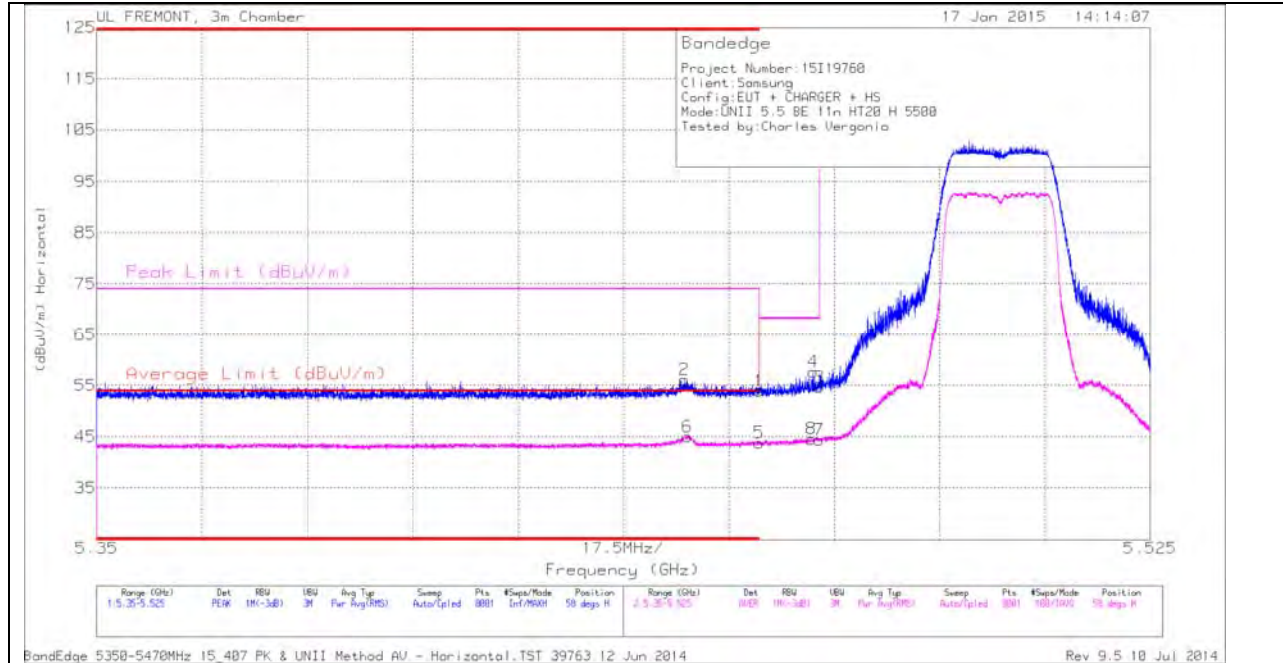

HORIZONTAL DATA

Marker	Frequency (GHz)	Meter Reading (dBuV)	Det	AF T711 (dB/m)	Amp/Cbl/Fit r/Pad (dB)	DC Corr (dB)	Corrected Reading (dBuV/m)	Average Limit (dBuV/m)	Margin (dB)	Peak Limit (dBuV/m)	PK Margin (dB)	Azimuth (Degs)	Height (cm)	Polarity
2	* 5.448	43	PK	34.5	-21.4	0	56.1	-	-	74	-17.9	58	104	H
6	* 5.448	31.89	RMS	34.5	-21.4	.33	45.32	54	-8.68	-	-	58	104	H
1	* 5.46	40.81	PK	34.5	-21.4	0	53.91	-	-	74	-20.09	58	104	H
5	* 5.46	30.7	RMS	34.5	-21.4	.33	44.13	54	-9.87	-	-	58	104	H
4	5.469	44.45	PK	34.5	-21.3	0	57.65	-	-	68.2	-10.55	58	104	H
8	5.469	31.36	RMS	34.5	-21.3	.33	44.89	-	-	-	-	58	104	H
3	5.47	41.48	PK	34.5	-21.3	0	54.68	-	-	68.2	-13.52	58	104	H
7	5.47	31.14	RMS	34.5	-21.3	.33	44.67	-	-	-	-	58	104	H

VERTICAL PEAK AND AVERAGE PLOT

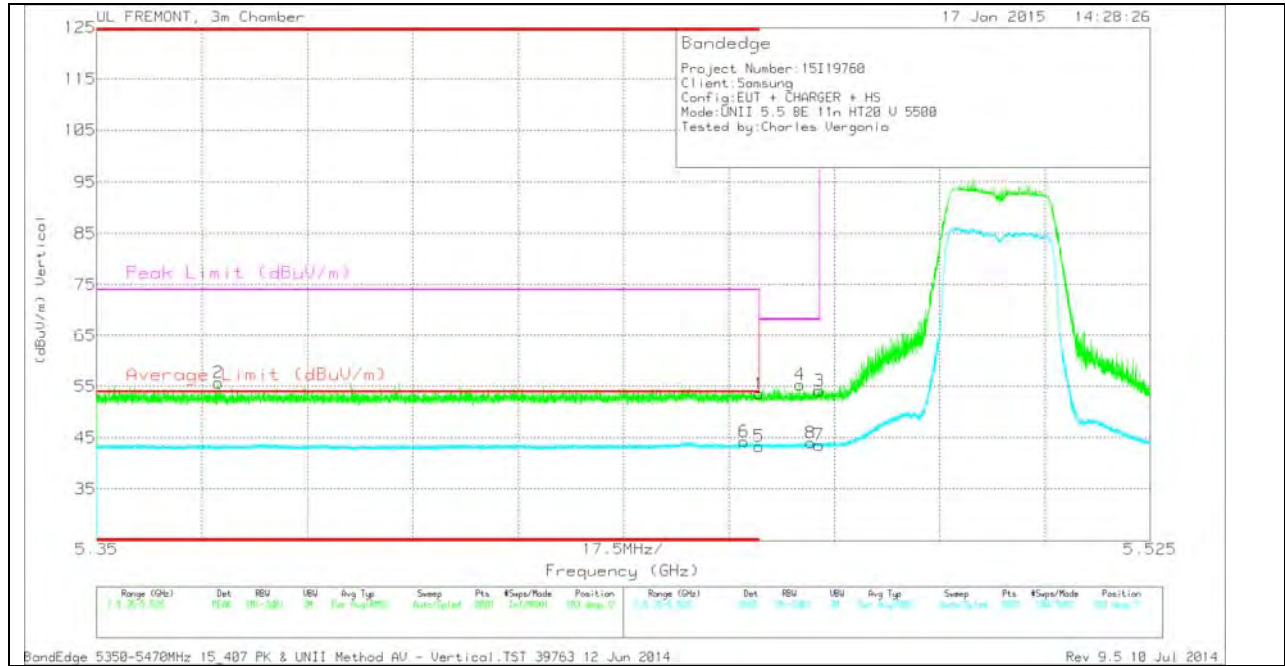

VERTICAL DATA

Marker	Frequency (GHz)	Meter Reading (dBuV)	Det	AF T711 (dB/m)	Amp/Cb/Fit r/Pad (dB)	DC Corr (dB)	Corrected Reading (dBuV/m)	Average Limit (dBuV/m)	Margin (dB)	Peak Limit (dBuV/m)	PK Margin (dB)	Azimuth (Degs)	Height (cm)	Polarity
2	* 5.37	42.92	PK	34.3	-21.5	0	55.72	-	-	74	-18.28	183	135	V
6	* 5.457	30.82	RMS	34.5	-21.4	.33	44.25	54	-9.75	-	-	183	135	V
1	* 5.46	40.48	PK	34.5	-21.4	0	53.58	-	-	74	-20.42	183	135	V
5	* 5.46	29.88	RMS	34.5	-21.4	.33	43.31	54	-10.69	-	-	183	135	V
4	5.467	42.14	PK	34.5	-21.3	0	55.34	-	-	68.2	-12.86	183	135	V
8	5.469	30.48	RMS	34.5	-21.3	.33	44.01	-	-	-	-	183	135	V
3	5.47	41	PK	34.5	-21.3	0	54.2	-	-	68.2	-14	183	135	V
7	5.47	30.04	RMS	34.5	-21.3	.33	43.57	-	-	-	-	183	135	V

AUTHORIZED BANDEDGE (HIGH CHANNEL)

HORIZONTAL PEAK PLOT

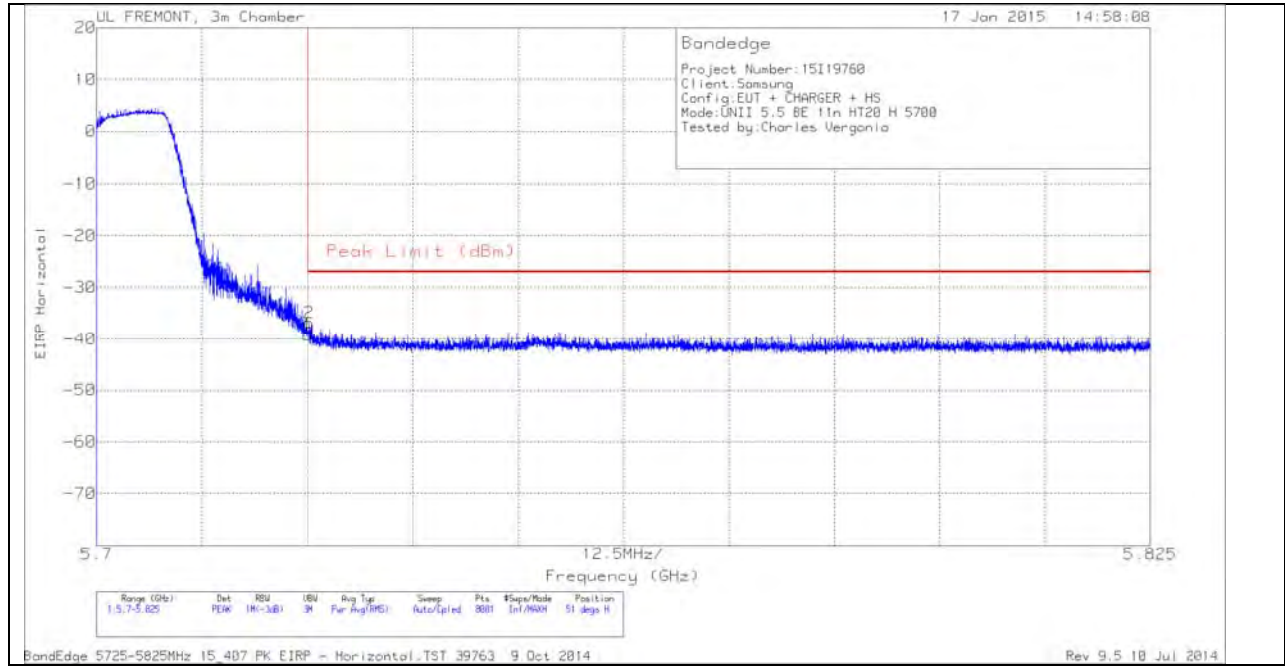

HORIZONTAL DATA

Marker	Frequency (GHz)	Meter Reading (dBm)	Det	AF T711 (dB/m)	Amp/Cbl/F ltr/Pad (dB)	Conversion Factor (dB)	Corrected Reading EIRP	Peak Limit (dBm)	PK Margin (dB)	Azimuth (Degs)	Height (cm)	Polarity
1	5.725	-65.09	PK	35.2	-21.1	11.8	-39.19	-27	-12.19	51	132	H
2	5.725	-62.74	PK	35.2	-21.1	11.8	-36.84	-27	-9.84	51	132	H

VERTICAL PEAK PLOT

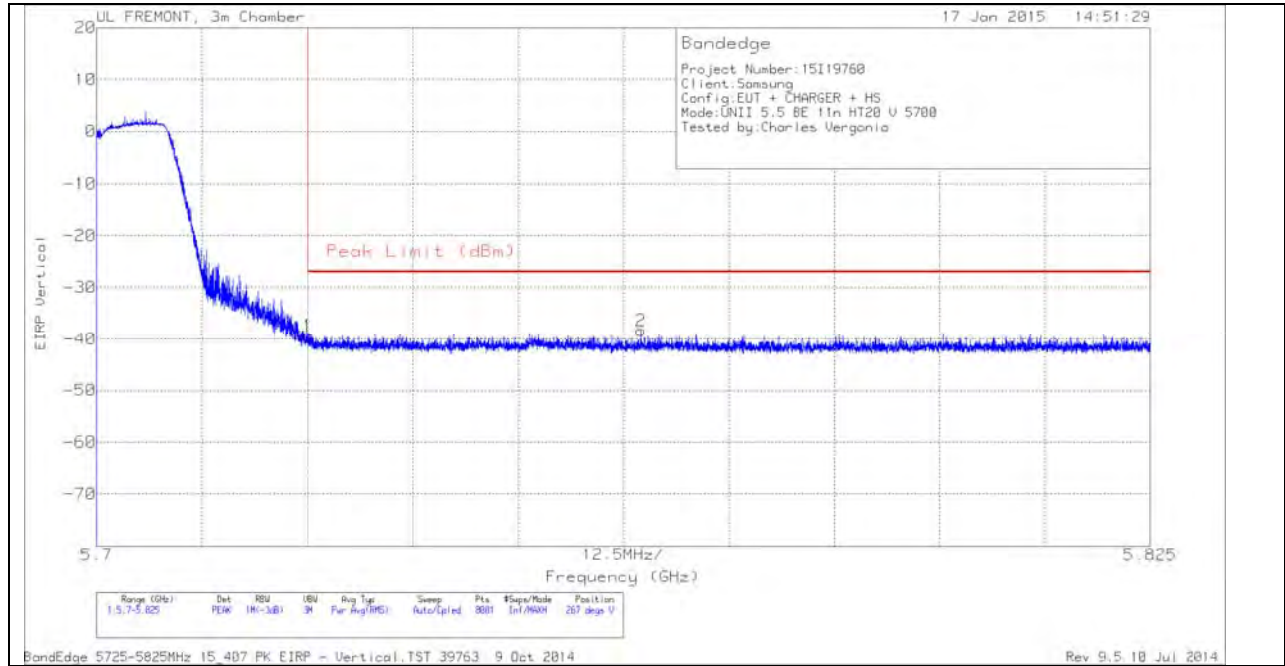

VERTICAL DATA

Marker	Frequency (GHz)	Meter Reading (dBm)	Det	AF T711 (dB/m)	Amp/Cbl/F ltr/Pad (dB)	Conversion Factor (dB)	Corrected Reading EIRP	Peak Limit (dBm)	PK Margin (dB)	Azimuth (Degs)	Height (cm)	Polarity
1	5.725	-65.32	PK	35.2	-21.1	11.8	-39.42	-27	-12.42	267	226	V
2	5.765	-64.38	PK	35.3	-21.1	11.8	-38.38	-27	-11.38	267	226	V

HARMONICS AND SPURIOUS EMISSIONS

LOW CHANNEL HORIZONTAL

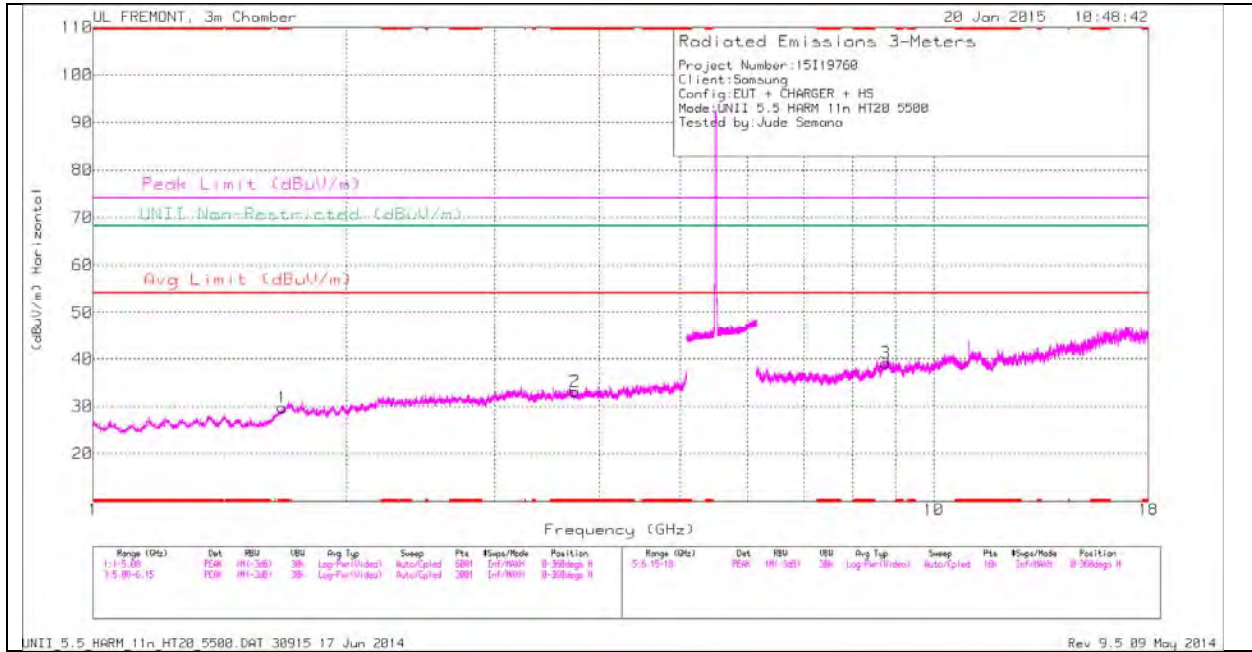

Note: Emission was scanned up to 40GHz; No emissions were detected above the noise floor which was at least 20dB below the specification limit.

LOW CHANNEL VERTICAL

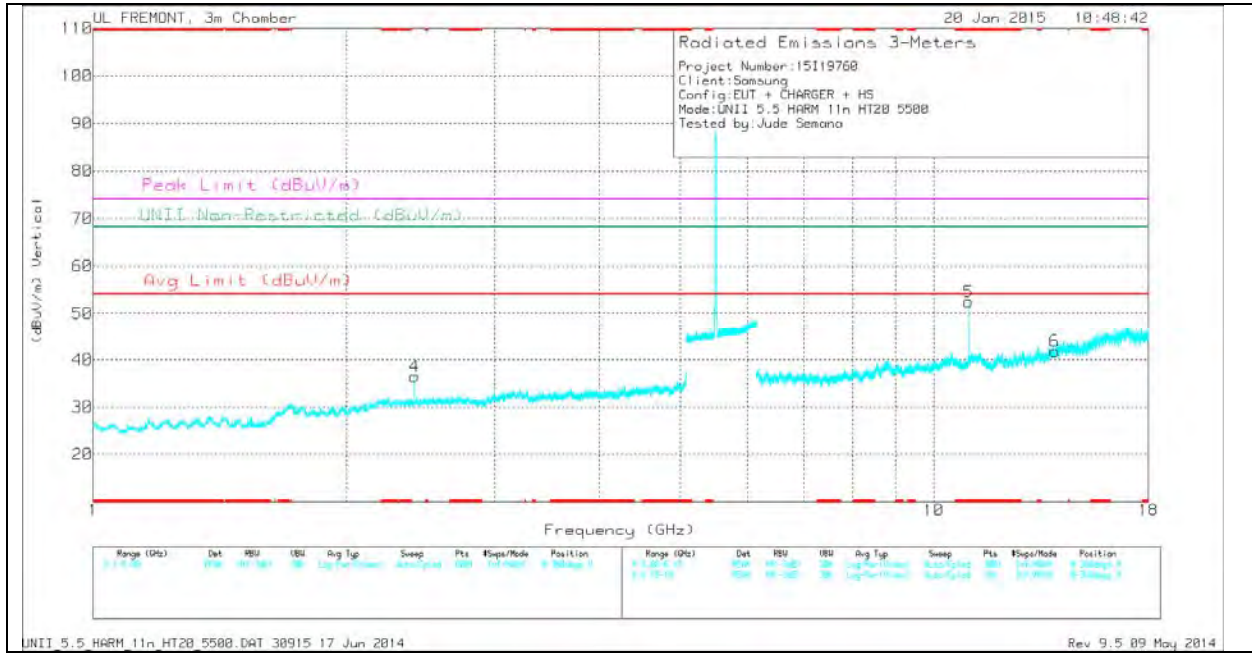

Note: Emission was scanned up to 40GHz; No emissions were detected above the noise floor which was at least 20dB below the specification limit.

LOW CHANNEL DATA

TRACE MARKERS

Marker	Frequency (GHz)	Meter Reading (dBuV)	Det	AF T711 (dB/m)	Amp/Cbl/Ftr/Pad (dB)	DC Corr (dB)	Corrected Reading (dBuV/m)	Avg Limit (dBuV/m)	Margin (dB)	Peak Limit (dBuV/m)	PK Margin (dB)	UNII Non-Restricted (dBuV/m)	PK Margin (dB)	Azimuth (Degs)	Height (cm)	Polarity
1	* 1.679	32.23	PK	30.1	-32.5	0	29.83	-	-	74	-44.17	-	-	0-360	100	H
2	* 3.74	31.67	PK	32.9	-31.4	0	33.17	-	-	74	-40.83	-	-	0-360	100	H
5	* 11	39.54	PK	38.3	-25.4	0	52.44	-	-	74	-21.56	-	-	0-360	200	V
4	2.41	37.11	PK	32.1	-32.7	0	36.51	-	-	-	-	68.2	-31.69	0-360	200	V
3	8.764	28.53	PK	36.6	-26	0	39.13	-	-	-	-	68.2	-29.07	0-360	200	H
6	13.922	30.02	PK	39.4	-27.6	0	41.82	-	-	-	-	68.2	-26.38	0-360	200	V

* - indicates frequency in CFR15.205/IC7.2.2 Restricted Band

PK - Peak detector

Radiated Emissions

Frequency (GHz)	Meter Reading (dBuV)	Det	AF T711 (dB/m)	Amp/Cbl/Ftr/Pad (dB)	DC Corr (dB)	Corrected Reading (dBuV/m)	Avg Limit (dBuV/m)	Margin (dB)	Peak Limit (dBuV/m)	PK Margin (dB)	UNII Non-Restricted (dBuV/m)	PK Margin (dB)	Azimuth (Degs)	Height (cm)	Polarity
* 11	42.76	PK1	38.3	-25.4	0	55.66	-	-	74	-18.34	-	-	318	233	V
* 11	39.04	AD1	38.3	-25.4	.33	52.26	54	-1.74	-	-	-	-	318	233	V

* - indicates frequency in CFR15.205/IC7.2.2 Restricted Band

PK1 - KDB789033 Method: Peak

AD1 - KDB789033 Method: AD Primary Power Average

MID CHANNEL HORIZONTAL

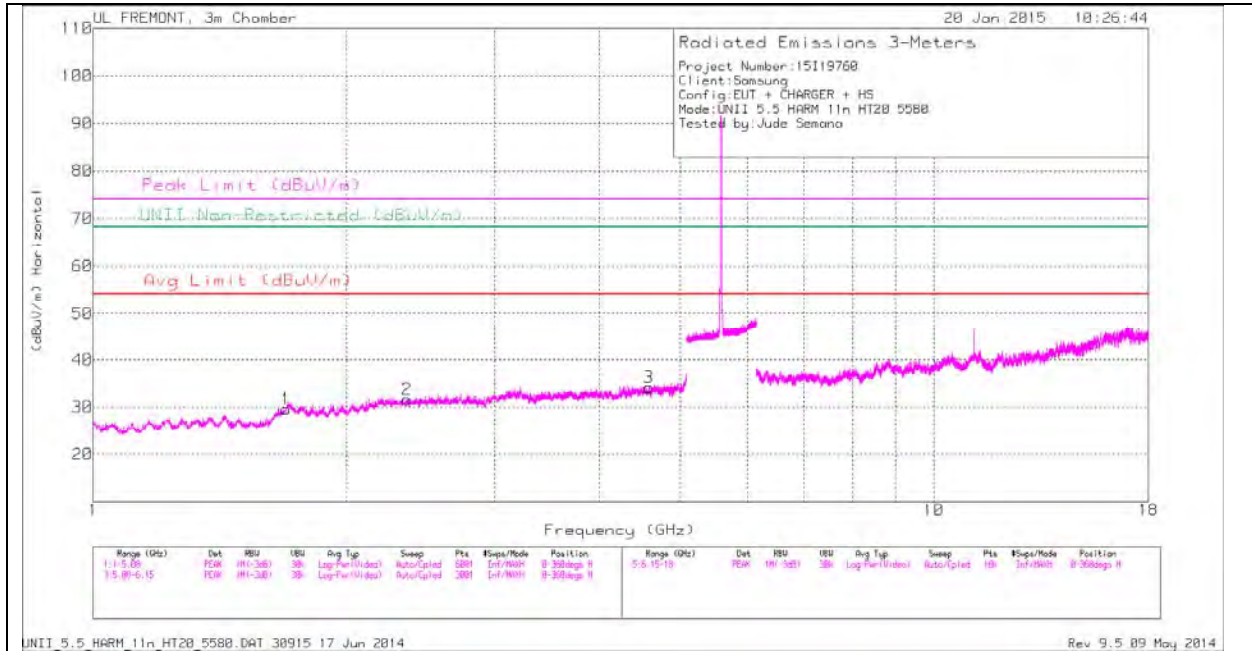

Note: Emission was scanned up to 40GHz; No emissions were detected above the noise floor which was at least 20dB below the specification limit.

MID CHANNEL VERTICAL

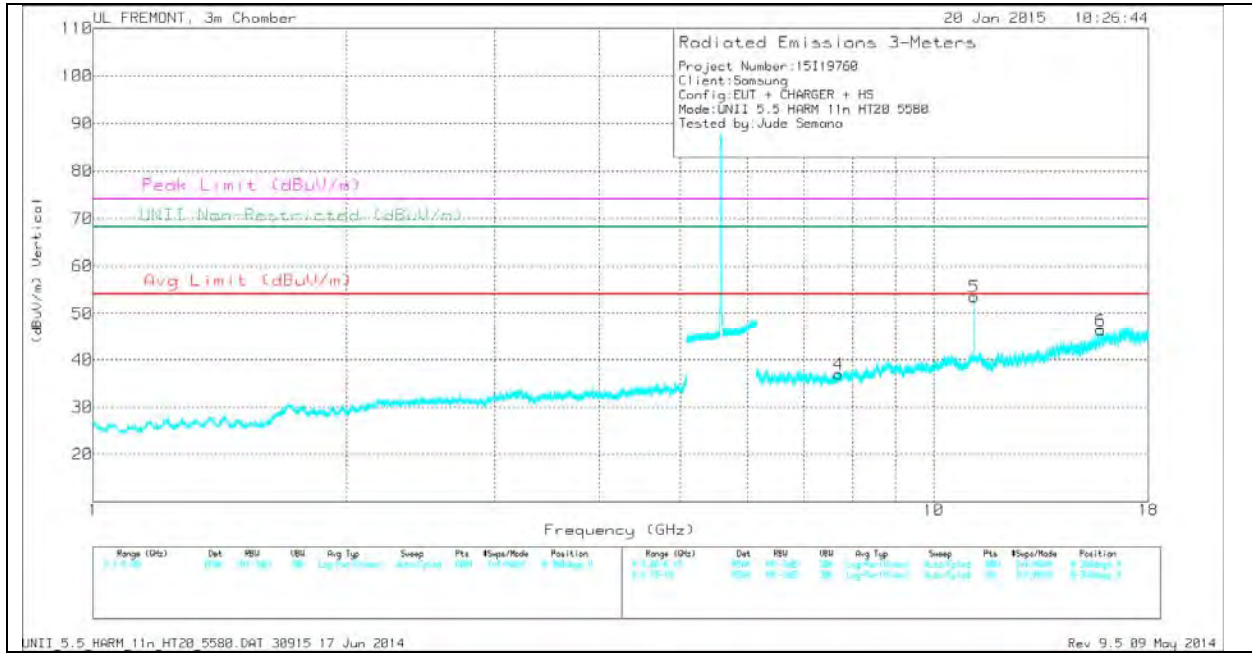

Note: Emission was scanned up to 40GHz; No emissions were detected above the noise floor which was at least 20dB below the specification limit.

MID CHANNEL DATA

TRACE MARKERS

Marker	Frequency (GHz)	Meter Reading (dBuV)	Det	AF T711 (dB/m)	Amp/Cbl/Ftr/Pad (dB)	DC Corr (dB)	Corrected Reading (dBuV/m)	Avg Limit (dBuV/m)	Margin (dB)	Peak Limit (dBuV/m)	PK Margin (dB)	UNII Non-Restricted (dBuV/m)	PK Margin (dB)	Azimuth (Degs)	Height (cm)	Polarity
1	1.696	31.19	PK	30.6	-32.2	0	29.59	-	-	74	-44.41	-	-	0-360	200	H
2	2.363	32.44	PK	32	-32.8	0	31.64	-	-	74	-42.36	-	-	0-360	100	H
3	4.582	31.27	PK	33.5	-30.6	0	34.17	-	-	74	-39.83	-	-	0-360	100	H
4	7.702	30.36	PK	35.7	-29.1	0	36.96	-	-	74	-37.04	-	-	0-360	101	V
5	11.16	41.04	PK	38.3	-25.8	0	53.54	-	-	74	-20.46	-	-	0-360	101	V
6	15.803	31.25	PK	41.7	-26.6	0	46.35	-	-	74	-27.65	-	-	0-360	101	V

PK - Peak detector

Radiated Emissions

Frequency (GHz)	Meter Reading (dBuV)	Det	AF T711 (dB/m)	Amp/Cbl/Ftr/Pad (dB)	DC Corr (dB)	Corrected Reading (dBuV/m)	Avg Limit (dBuV/m)	Margin (dB)	Peak Limit (dBuV/m)	PK Margin (dB)	UNII Non-Restricted (dBuV/m)	PK Margin (dB)	Azimuth (Degs)	Height (cm)	Polarity
11.16	43.99	PK1	38.3	-25.8	0	56.49	-	-	74	-17.51	-	-	66	185	V
11.16	40.16	AD1	38.3	-25.8	.33	52.96	54	-1.04	-	-	-	-	66	185	V

PK1 - KDB789033 Method: Peak

AD1 - KDB789033 Method: AD Primary Power Average

HIGH CHANNEL HORIZONTAL

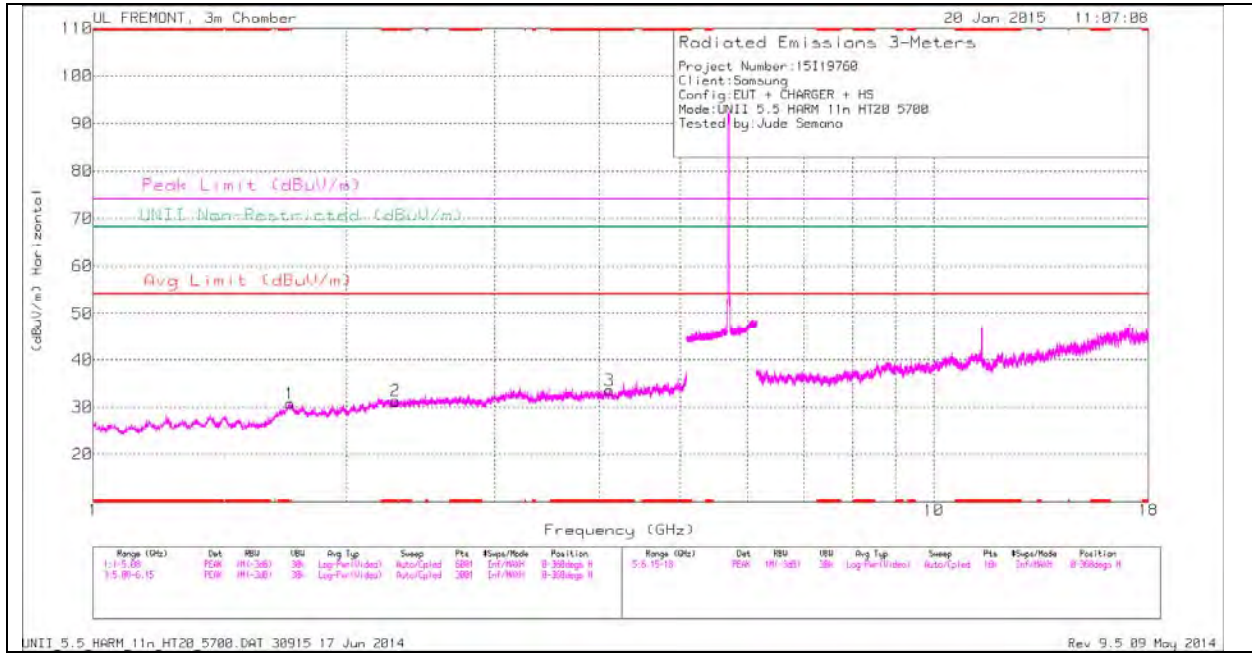

Note: Emission was scanned up to 40GHz; No emissions were detected above the noise floor which was at least 20dB below the specification limit.

HIGH CHANNEL VERTICAL

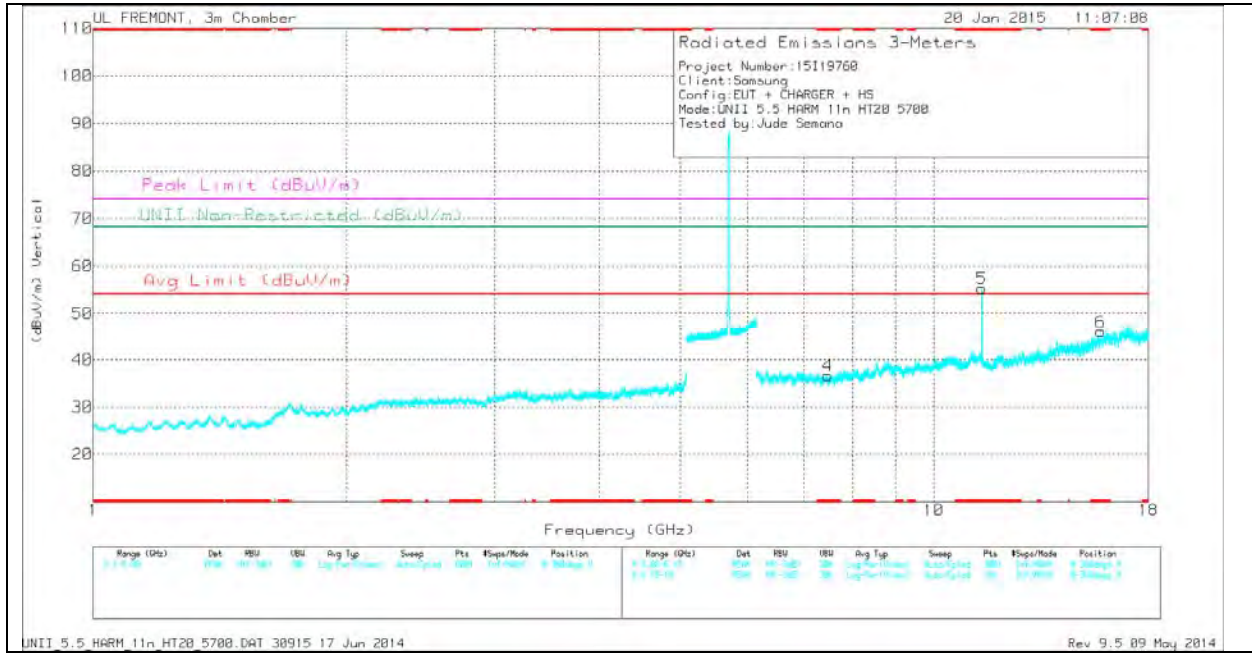

Note: Emission was scanned up to 40GHz; No emissions were detected above the noise floor which was at least 20dB below the specification limit.

HIGH CHANNEL DATA

TRACE MARKERS

Marker	Frequency (GHz)	Meter Reading (dBuV)	Det	AF T711 (dB/m)	Amp/Cbl/Ftr/Pad (dB)	DC Corr (dB)	Corrected Reading (dBuV/m)	Avg Limit (dBuV/m)	Margin (dB)	Peak Limit (dBuV/m)	PK Margin (dB)	UNII Non-Restricted (dBuV/m)	PK Margin (dB)	Azimuth (Degs)	Height (cm)	Polarity
2	* 2.289	31.73	PK	31.9	-32.3	0	31.33	-	-	74	-42.67	-	-	0-360	200	H
3	* 4.112	31.17	PK	33.2	-30.8	0	33.57	-	-	74	-40.43	-	-	0-360	200	H
4	* 7.482	29.85	PK	35.5	-28.7	0	36.65	-	-	74	-37.35	-	-	0-360	100	V
5	* 11.4	43.06	PK	38.2	-26	0	55.26	-	-	74	-18.74	-	-	0-360	200	V
6	* 15.8	31.06	PK	41.7	-26.7	0	46.06	-	-	74	-27.94	-	-	0-360	200	V
1	1.715	32.26	PK	30.6	-32.1	0	30.76	-	-	-	-	68.2	-37.44	0-360	200	H

* - indicates frequency in CFR15.205/IC7.2.2 Restricted Band

PK - Peak detector

Radiated Emissions

Frequency (GHz)	Meter Reading (dBuV)	Det	AF T711 (dB/m)	Amp/Cbl/Ftr/Pad (dB)	DC Corr (dB)	Corrected Reading (dBuV/m)	Avg Limit (dBuV/m)	Margin (dB)	Peak Limit (dBuV/m)	PK Margin (dB)	UNII Non-Restricted (dBuV/m)	PK Margin (dB)	Azimuth (Degs)	Height (cm)	Polarity
* 11.4	45.09	PK1	38.2	-26	0	57.29	-	-	74	-16.71	-	-	52	169	V
* 11.4	41.38	AD1	38.2	-26	.33	53.88	54	-12	-	-	-	-	52	169	V

* - indicates frequency in CFR15.205/IC7.2.2 Restricted Band

PK1 - KDB789033 Method: Peak

AD1 - KDB789033 Method: AD Primary Power Average

**11.3.3. TX ABOVE 1 GHz 802.11n HT40 MODE IN THE 5.5 GHz BAND
 RESTRICTED BANDEDGE (LOW CHANNEL)**

HORIZONTAL PEAK AND AVERAGE PLOT

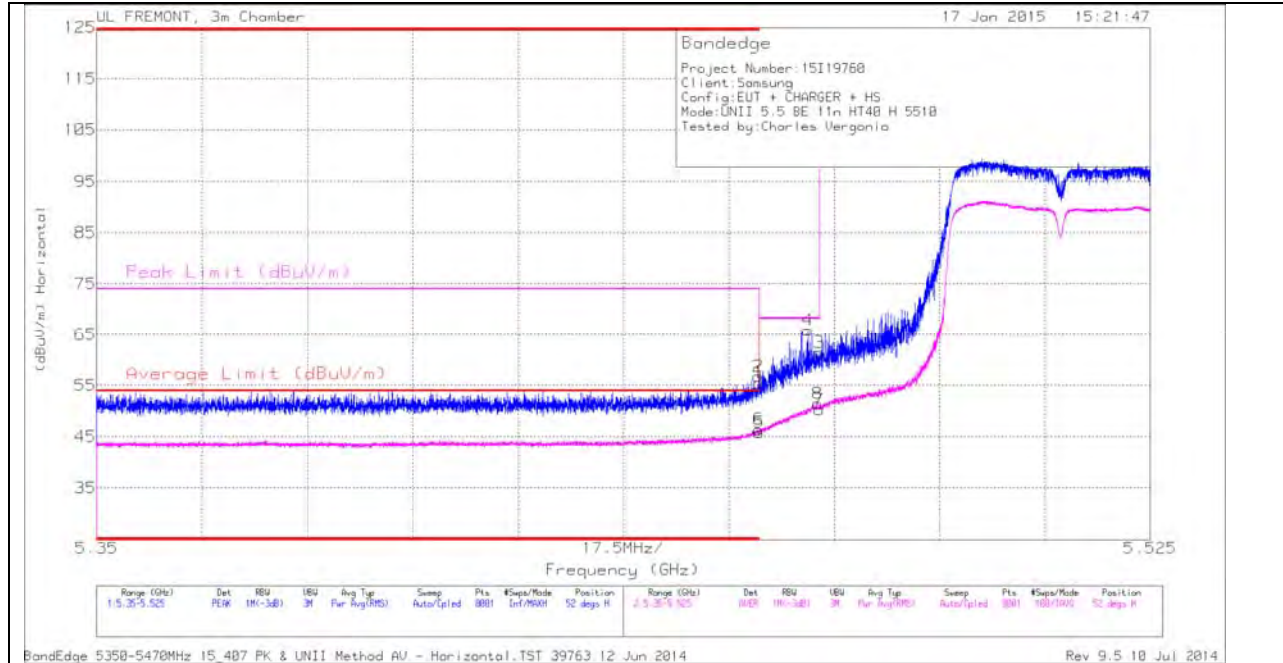

HORIZONTAL DATA

Marker	Frequency (GHz)	Meter Reading (dBuV)	Det	AF T711 (dB/m)	Amp/Cbl/Fit r/Pad (dB)	DC Corr (dB)	Corrected Reading (dBuV/m)	Average Limit (dBuV/m)	Margin (dB)	Peak Limit (dBuV/m)	PK Margin (dB)	Azimuth (Degs)	Height (cm)	Polarity
1	* 5.46	42.38	PK	34.5	-21.4	0	55.48	-	-	74	-18.52	52	103	H
2	* 5.46	43.64	PK	34.5	-21.4	0	56.74	-	-	74	-17.26	52	103	H
5	* 5.46	32.07	RMS	34.5	-21.4	.64	45.81	54	-8.19	-	-	52	103	H
6	* 5.46	32.65	RMS	34.5	-21.4	.64	46.39	54	-7.61	-	-	52	103	H
4	5.468	51.69	PK	34.5	-21.3	0	64.89	-	-	68.2	-3.31	52	103	H
3	5.47	48.25	PK	34.5	-21.3	0	61.45	-	-	68.2	-6.75	52	103	H
7	5.47	36.41	RMS	34.5	-21.3	.64	50.25	-	-	-	-	52	103	H
8	5.47	37.62	RMS	34.5	-21.3	.64	51.46	-	-	-	-	52	103	H

VERTICAL PEAK AND AVERAGE PLOT

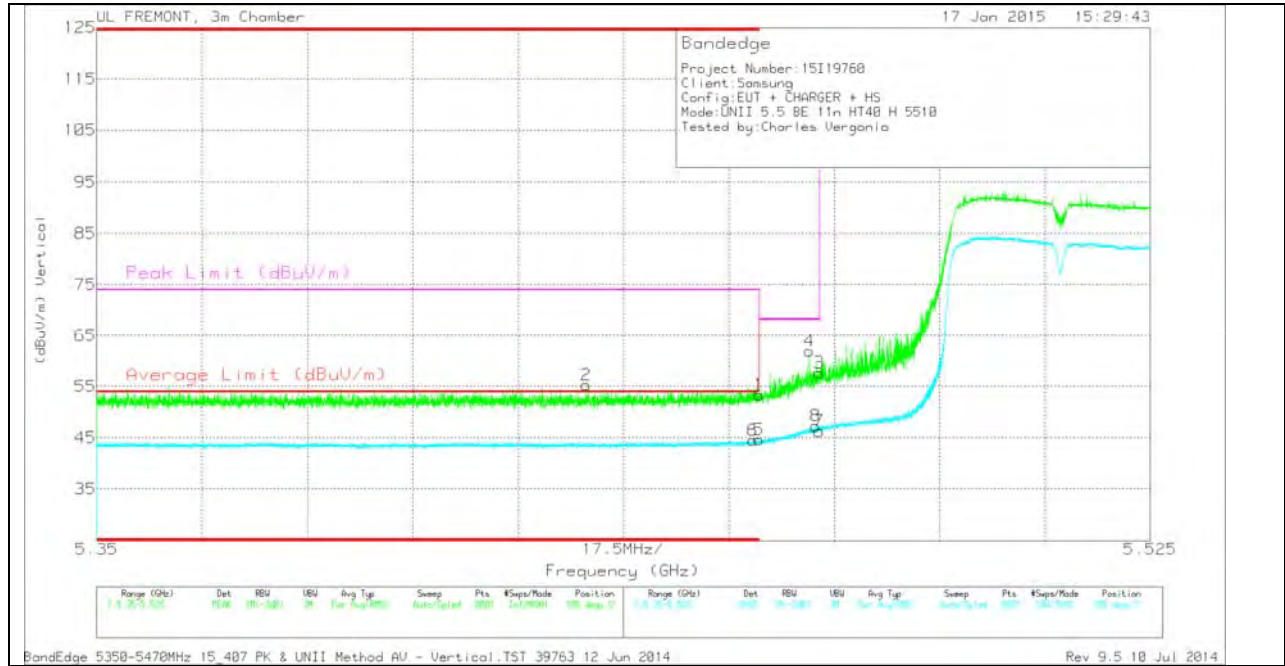

VERTICAL DATA

Marker	Frequency (GHz)	Meter Reading (dBuV)	Det	AF T711 (dB/m)	Amp/Cbl/Fit r/Pad (dB)	DC Corr (dB)	Corrected Reading (dBuV/m)	Average Limit (dBuV/m)	Margin (dB)	Peak Limit (dBuV/m)	PK Margin (dB)	Azimuth (Degs)	Height (cm)	Polarity
2	* 5.431	42.36	PK	34.4	-21.5	0	55.26	-	-	74	-18.74	185	130	V
6	* 5.459	30.76	RMS	34.5	-21.4	.64	44.5	54	-9.5	-	-	185	130	V
1	* 5.46	40.27	PK	34.5	-21.4	0	53.37	-	-	74	-20.63	185	130	V
5	* 5.46	30.84	RMS	34.5	-21.4	.64	44.58	54	-9.42	-	-	185	130	V
4	5.468	48.72	PK	34.5	-21.3	0	61.92	-	-	68.2	-6.28	185	130	V
8	5.469	33.42	RMS	34.5	-21.3	.64	47.26	-	-	-	-	185	130	V
3	5.47	44.45	PK	34.5	-21.3	0	57.65	-	-	68.2	-10.55	185	130	V
7	5.47	32.44	RMS	34.5	-21.3	.64	46.28	-	-	-	-	185	130	V

AUTHORIZED BANDEDGE (HIGH CHANNEL)

HORIZONTAL PEAK PLOT

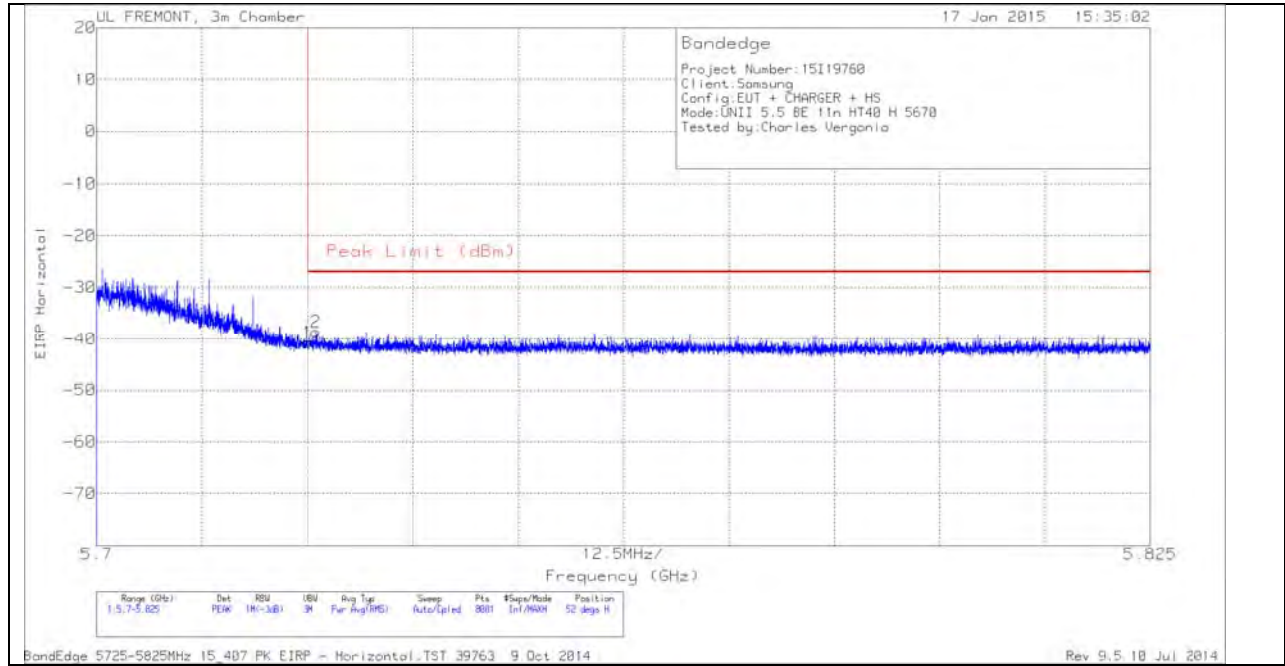

HORIZONTAL DATA

Marker	Frequency (GHz)	Meter Reading (dBm)	Det	AF T711 (dB/m)	Amp/Cbl/F ltr/Pad (dB)	Conversion Factor (dB)	Corrected Reading EIRP	Peak Limit (dBm)	PK Margin (dB)	Azimuth (Degs)	Height (cm)	Polarity
1	5.725	-66.58	PK	35.2	-21.1	11.8	-40.68	-27	-13.68	52	165	H
2	5.726	-64.52	PK	35.2	-21.1	11.8	-38.62	-27	-11.62	52	165	H

VERTICAL PEAK AND AVERAGE PLOT

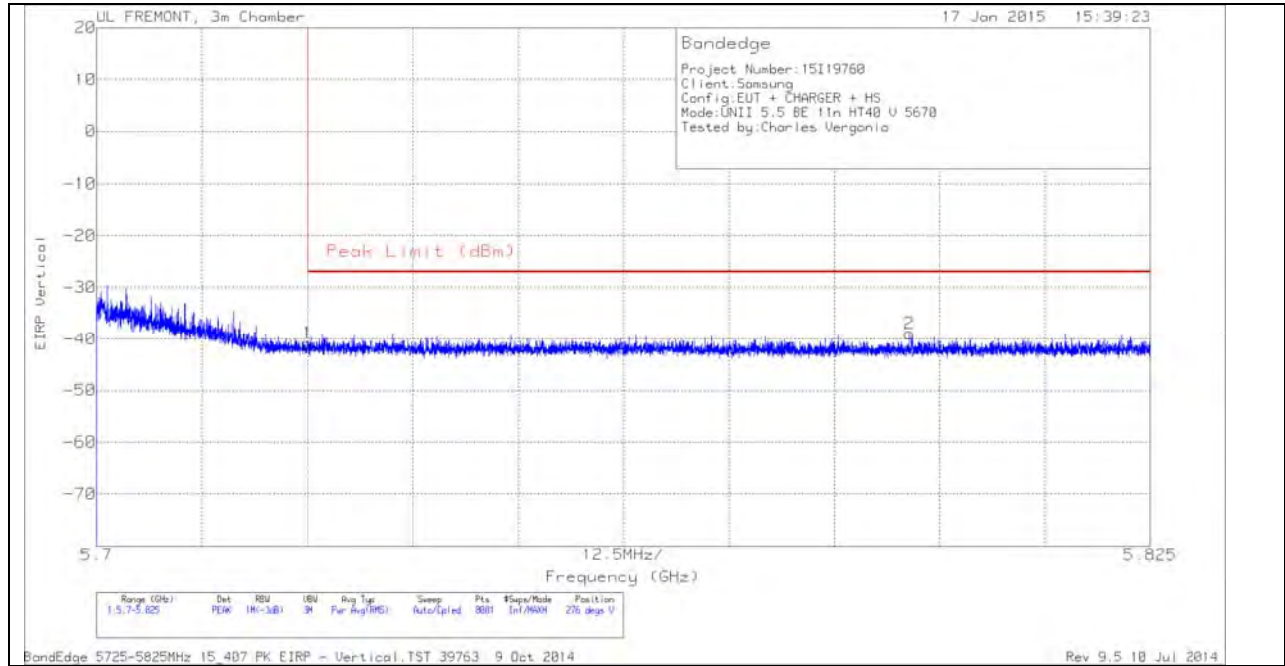

VERTICAL DATA

Marker	Frequency (GHz)	Meter Reading (dBm)	Det	AF T711 (dB/m)	Amp/Cbl/F ltr/Pad (dB)	Conversion Factor (dB)	Corrected Reading EIRP	Peak Limit (dBm)	PK Margin (dB)	Azimuth (Degs)	Height (cm)	Polarity
1	5.725	-66.77	PK	35.2	-21.1	11.8	-40.87	-27	-13.87	276	193	V
2	5.796	-64.93	PK	35.4	-21.2	11.8	-38.93	-27	-11.93	276	193	V

HARMONICS AND SPURIOUS EMISSIONS

LOW CHANNEL HORIZONTAL

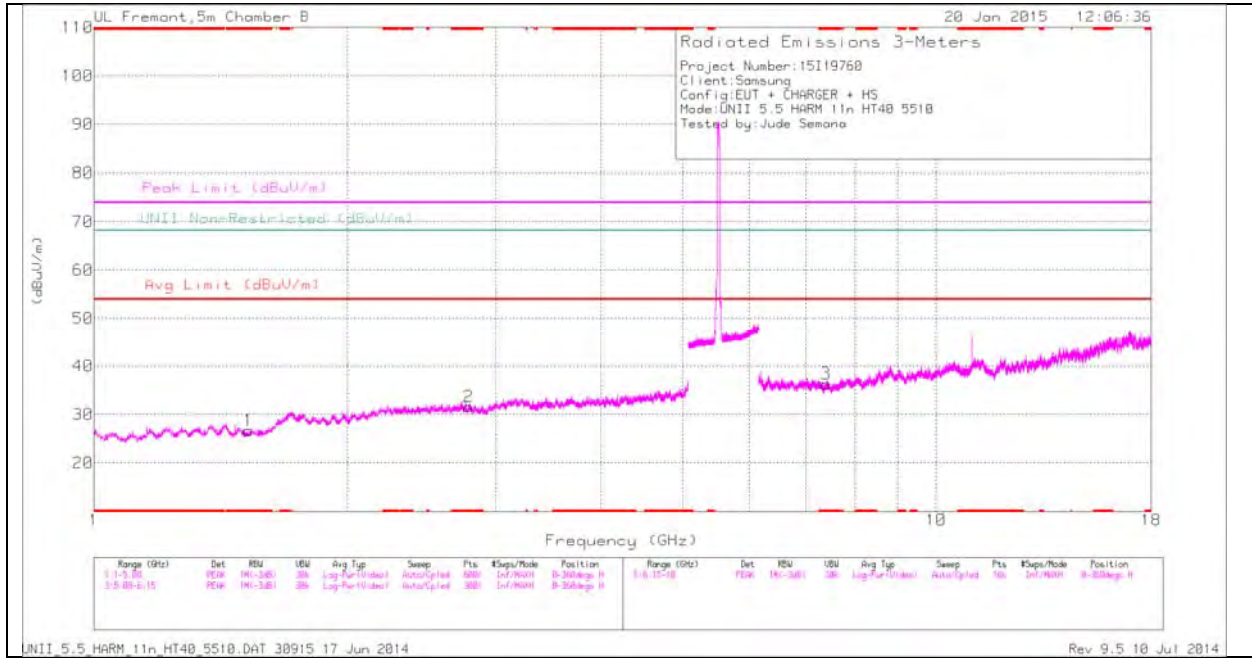

Note: Emission was scanned up to 40GHz; No emissions were detected above the noise floor which was at least 20dB below the specification limit.

LOW CHANNEL VERTICAL

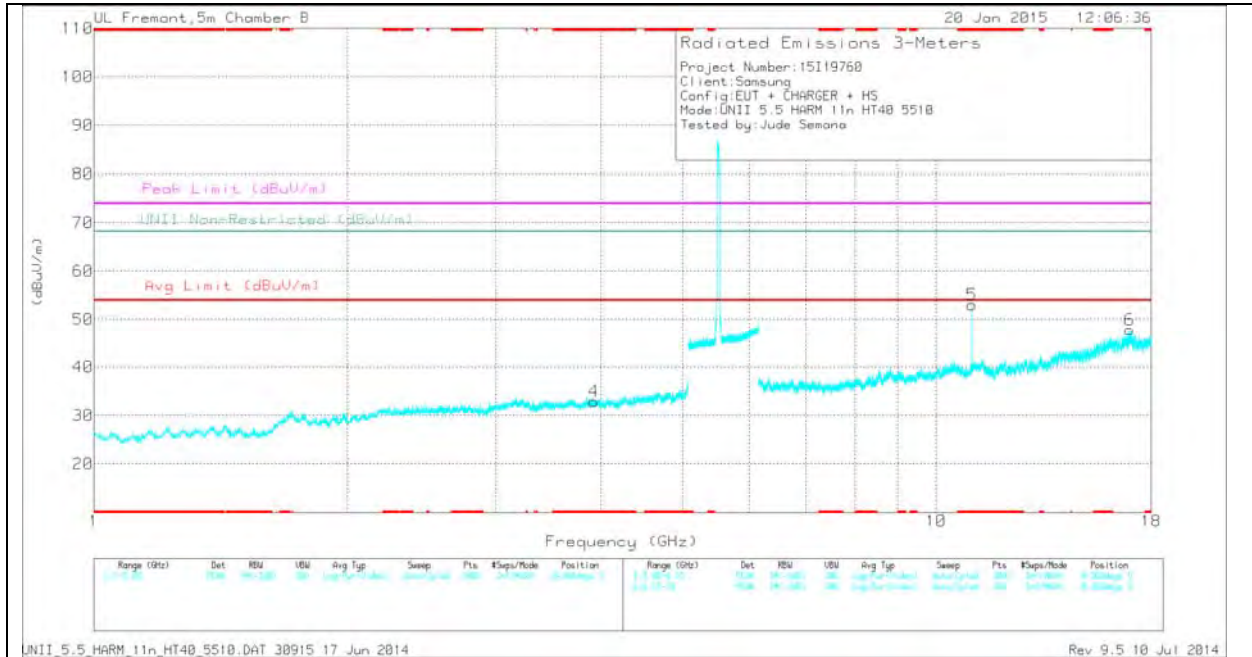

Note: Emission was scanned up to 40GHz; No emissions were detected above the noise floor which was at least 20dB below the specification limit.

LOW CHANNEL DATA

TRACE MARKERS

Marker	Frequency (GHz)	Meter Reading (dBuV)	Det	AF T711 (dB/m)	Amp/Cbl/Ftr/Pad (dB)	DC Corr (dB)	Corrected Reading (dBuV/m)	Avg Limit (dBuV/m)	Margin (dB)	Peak Limit (dBuV/m)	PK Margin (dB)	UNII Non-Restricted (dBuV/m)	PK Margin (dB)	Azimuth (Degs)	Height (cm)	Polarity
1	* 1.526	32.3	PK	27.7	-33.3	0	26.7	-	-	74	-47.3	-	-	0-360	100	H
2	* 2.786	31.61	PK	32.4	-32.4	0	31.61	-	-	74	-42.39	-	-	0-360	100	H
4	* 3.919	31.04	PK	33.1	-31.2	0	32.94	-	-	74	-41.06	-	-	0-360	200	V
3	* 7.394	29.35	PK	35.6	-28.6	0	36.35	-	-	74	-37.65	-	-	0-360	200	H
5	* 11.02	40.29	PK	38.3	-25.5	0	53.09	-	-	74	-20.91	-	-	0-360	100	V
6	16.979	28.64	PK	42.7	-23.5	0	47.84	-	-	-	-	68.2	-20.36	0-360	200	V

* - indicates frequency in CFR15.205/IC7.2.2 Restricted Band

PK - Peak detector

Radiated Emissions

Frequency (GHz)	Meter Reading (dBuV)	Det	AF T711 (dB/m)	Amp/Cbl/Ftr/Pad (dB)	DC Corr (dB)	Corrected Reading (dBuV/m)	Avg Limit (dBuV/m)	Margin (dB)	Peak Limit (dBuV/m)	PK Margin (dB)	UNII Non-Restricted (dBuV/m)	PK Margin (dB)	Azimuth (Degs)	Height (cm)	Polarity
* 11.02	42.33	PK1	38.3	-25.5	0	55.13	-	-	74	-18.87	-	-	317	244	V
* 11.02	38.66	AD1	38.3	-25.5	64	52.06	54	-1.94	-	-	-	-	317	244	V

* - indicates frequency in CFR15.205/IC7.2.2 Restricted Band

PK1 - KDB789033 Method: Peak

AD1 - KDB789033 Method: AD Primary Power Average

MID CHANNEL HORIZONTAL

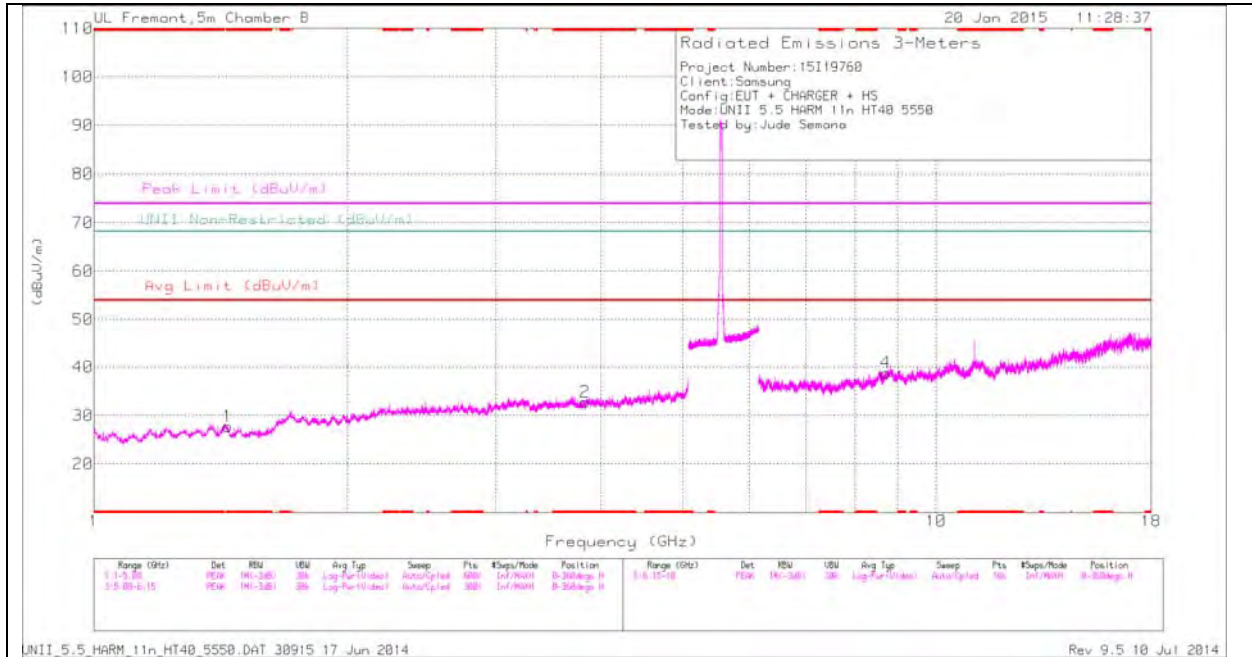

Note: Emission was scanned up to 40GHz; No emissions were detected above the noise floor which was at least 20dB below the specification limit.

MID CHANNEL VERTICAL

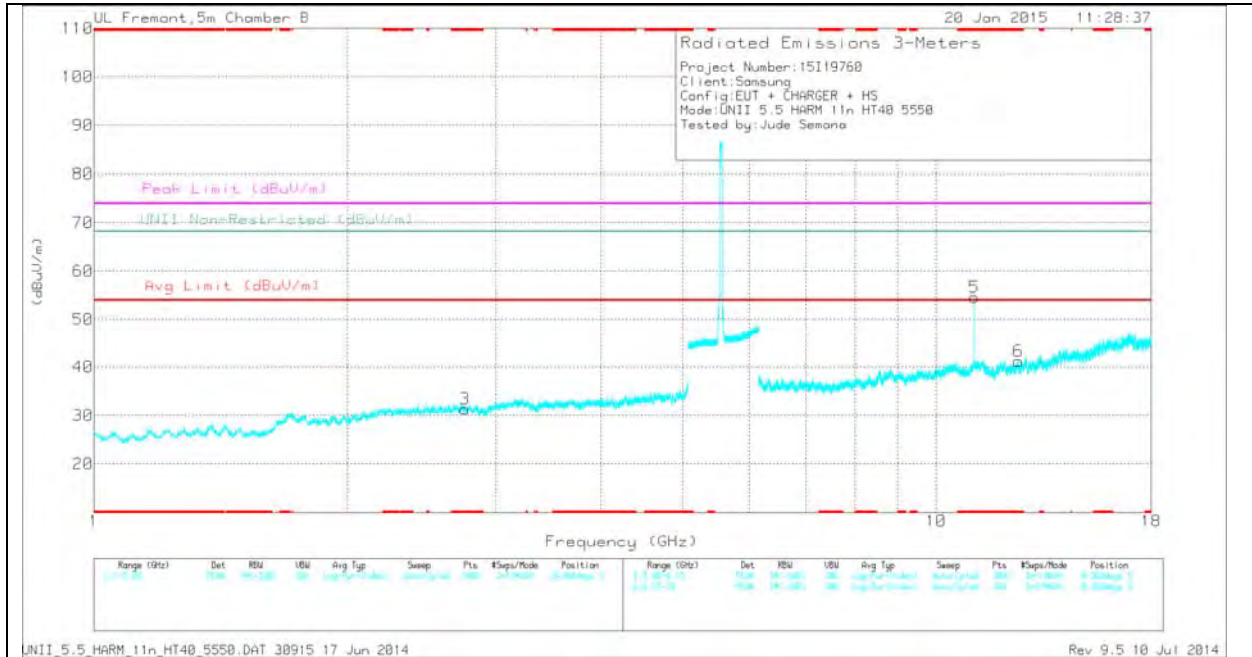

Note: Emission was scanned up to 40GHz; No emissions were detected above the noise floor which was at least 20dB below the specification limit.

MID CHANNEL DATA

TRACE MARKERS

Marker	Frequency (GHz)	Meter Reading (dBuV)	Det	AF T711 (dB/m)	Amp/Cbl/Ftr/Pad (dB)	DC Corr (dB)	Corrected Reading (dBuV/m)	Avg Limit (dBuV/m)	Margin (dB)	Peak Limit (dBuV/m)	PK Margin (dB)	UNII Non-Restricted (dBuV/m)	PK Margin (dB)	Azimuth (Degs)	Height (cm)	Polarity
1	* 1.441	32.37	PK	28.1	-32.7	0	27.77	-	-	74	-46.23	-	-	0-360	200	H
2	* 3.83	31.03	PK	33	-31.2	0	32.83	-	-	74	-41.17	-	-	0-360	200	H
3	* 2.758	31.16	PK	32.4	-32.2	0	31.36	-	-	74	-42.64	-	-	0-360	200	V
5	* 11.1	41.55	PK	38.4	-25.3	0	54.65	-	-	74	-19.35	-	-	0-360	200	V
6	* 12.512	28.81	PK	38.8	-26.4	0	41.21	-	-	74	-32.79	-	-	0-360	200	V
4	8.714	30.22	PK	36.5	-27.9	0	38.82	-	-	-	-	68.2	-29.38	0-360	100	H

* - indicates frequency in CFR15.205/IC7.2.2 Restricted Band

PK - Peak detector

Radiated Emissions

Frequency (GHz)	Meter Reading (dBuV)	Det	AF T711 (dB/m)	Amp/Cbl/Ftr/Pad (dB)	DC Corr (dB)	Corrected Reading (dBuV/m)	Avg Limit (dBuV/m)	Margin (dB)	Peak Limit (dBuV/m)	PK Margin (dB)	UNII Non-Restricted (dBuV/m)	PK Margin (dB)	Azimuth (Degs)	Height (cm)	Polarity
* 11.1	43.51	PK1	38.4	-25.3	0	56.61	-	-	74	-17.39	-	-	322	150	V
* 11.1	40.14	AD1	38.4	-25.3	.64	53.84	54	-16	-	-	-	-	322	150	V

* - indicates frequency in CFR15.205/IC7.2.2 Restricted Band

PK1 - KDB789033 Method: Peak

AD1 - KDB789033 Method: AD Primary Power Average

HIGH CHANNEL HORIZONTAL

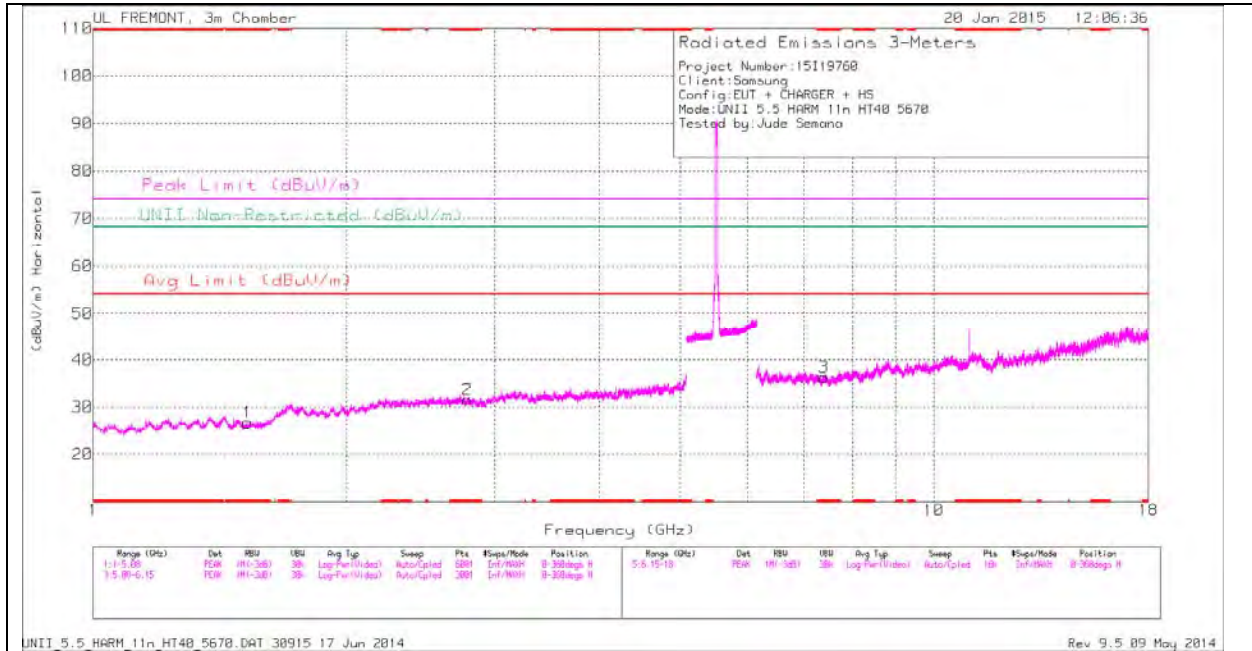

Note: Emission was scanned up to 40GHz; No emissions were detected above the noise floor which was at least 20dB below the specification limit.

HIGH CHANNEL VERTICAL

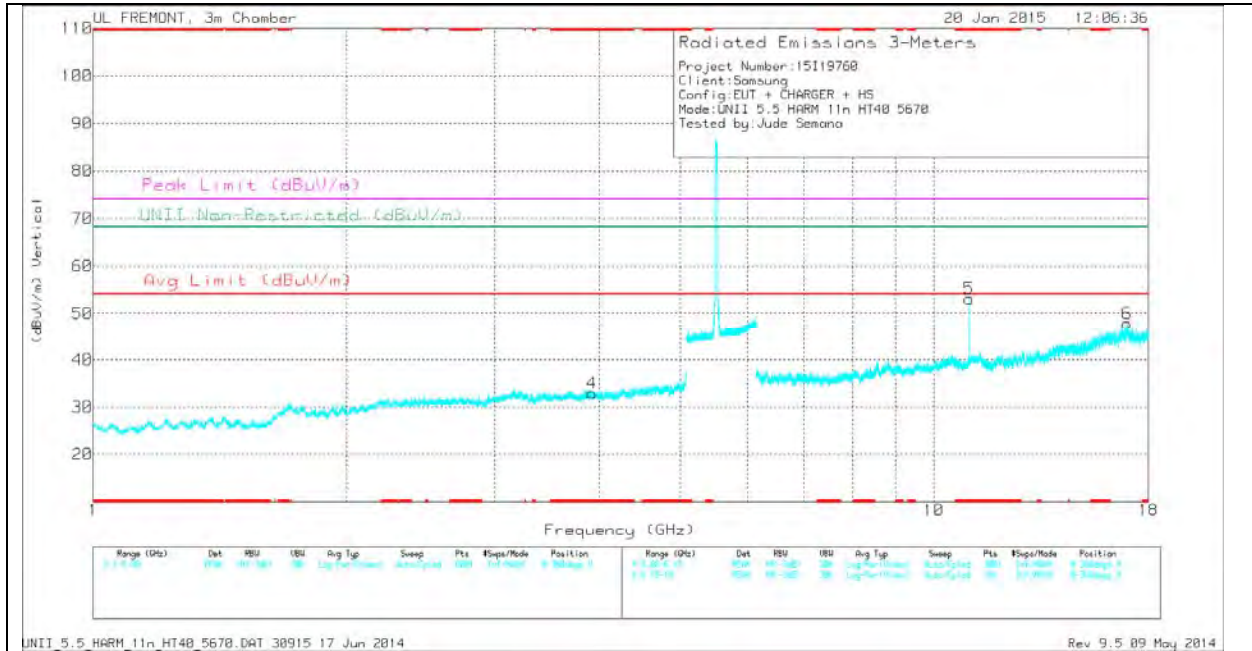

Note: Emission was scanned up to 40GHz; No emissions were detected above the noise floor which was at least 20dB below the specification limit.

HIGH CHANNEL DATA

TRACE MARKERS

Marker	Frequency (GHz)	Meter Reading (dBuV)	Det	AF T711 (dB/m)	Amp/Cbl/Ftr/Pad (dB)	DC Corr (dB)	Corrected Reading (dBuV/m)	Avg Limit (dBuV/m)	Margin (dB)	Peak Limit (dBuV/m)	PK Margin (dB)	UNII Non-Restricted (dBuV/m)	PK Margin (dB)	Azimuth (Degs)	Height (cm)	Polarity
1	* 1.526	32.3	PK	27.7	-33.3	0	26.7	-	-	74	-47.3	-	-	0-360	100	H
2	* 2.786	31.61	PK	32.4	-32.4	0	31.61	-	-	74	-42.39	-	-	0-360	100	H
4	* 3.919	31.04	PK	33.1	-31.2	0	32.94	-	-	74	-41.06	-	-	0-360	200	V
3	* 7.394	29.35	PK	35.6	-28.6	0	36.35	-	-	74	-37.65	-	-	0-360	200	H
5	* 11.02	40.29	PK	38.3	-25.5	0	53.09	-	-	74	-20.91	-	-	0-360	100	V
6	16.979	28.64	PK	42.7	-23.5	0	47.84	-	-	-	-	68.2	-20.36	0-360	200	V

* - indicates frequency in CFR15.205/IC7.2.2 Restricted Band

PK - Peak detector

Radiated Emissions

Frequency (GHz)	Meter Reading (dBuV)	Det	AF T711 (dB/m)	Amp/Cbl/Ftr/Pad (dB)	DC Corr (dB)	Corrected Reading (dBuV/m)	Avg Limit (dBuV/m)	Margin (dB)	Peak Limit (dBuV/m)	PK Margin (dB)	UNII Non-Restricted (dBuV/m)	PK Margin (dB)	Azimuth (Degs)	Height (cm)	Polarity
* 11.02	36.89	PK1	38.3	-25.5	0	49.69	-	-	74	-24.31	-	-	25	314	V
* 11.022	24.82	AD1	38.3	-25.5	.64	38.22	54	-15.78	-	-	-	-	25	314	V

* - indicates frequency in CFR15.205/IC7.2.2 Restricted Band

PK1 - KDB789033 Method: Peak

AD1 - KDB789033 Method: AD Primary Power Average

11.4. 5.8 GHz

11.4.1. TX ABOVE 1 GHz 802.11a MODE IN THE 5.8 GHz BAND

AUTHORIZED BANDEDGE (LOW CHANNEL)

HORIZONTAL PEAK PLOT

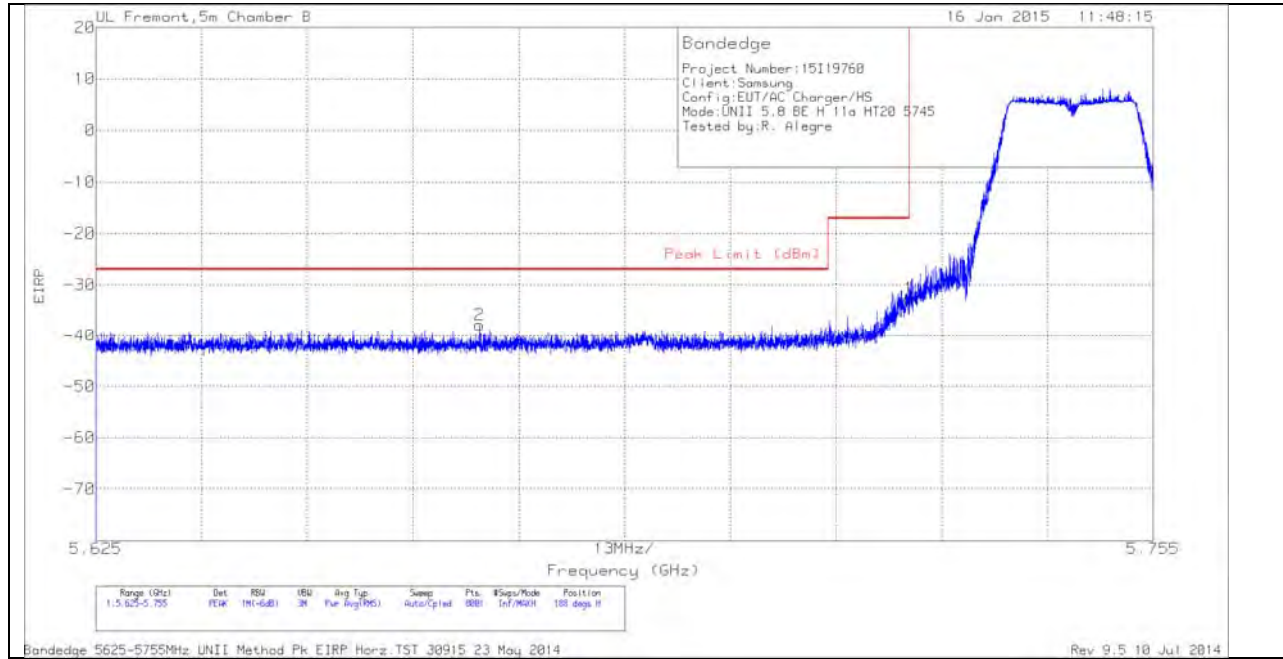

HORIZONTAL DATA

Marker	Frequency (GHz)	Meter Reading (dBm)	Det	AF T345 (dB/m)	Amp/Cb/ Ftr/Pad (dB)	Conversion Factor (dB)	DC Corr (dB)	Corrected Reading EIRP	Peak Limit (dBm)	PK Margin (dB)	Azimuth (Degs)	Height (cm)	Polarity
2	5.672	-63.86	PK	34.5	-20.2	11.8	0	-37.76	-27	-10.76	188	291	H
1	5.725	-58.95	PK	34.6	-20.1	11.8	0	-32.65	-17	-15.65	188	291	H

VERTICAL PEAK PLOT

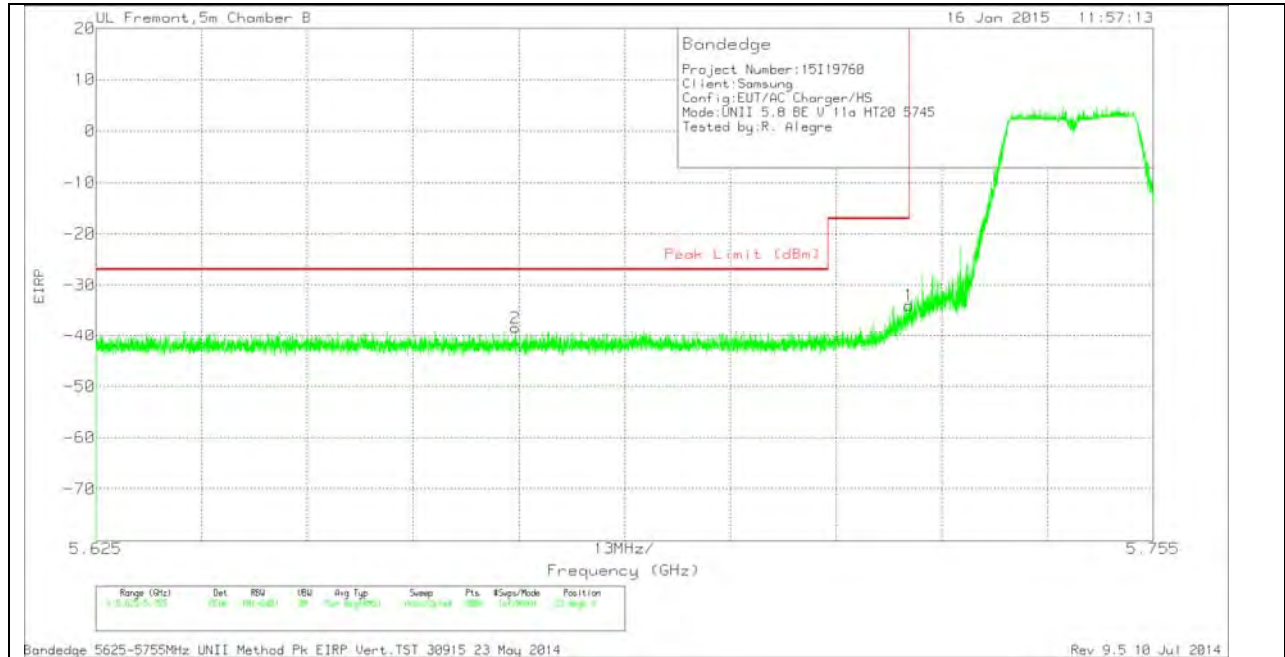

VERTICAL DATA

Marker	Frequency (GHz)	Meter Reading (dBm)	Det	AF T345 (dB/m)	Amp/Cbl/F ltr/Pad (dB)	Conversion Factor (dB)	Corrected Reading EIRP	Peak Limit (dBm)	PK Margin (dB)	Azimuth (Degs)	Height (cm)	Polarity
2	5.677	-64.58	PK	34.5	-20.2	11.8	-38.48	-27	-11.48	23	255	V
1	5.725	-60.35	PK	34.6	-20.1	11.8	-34.05	-17	-17.05	23	255	V

AUTHORIZED BANDEGE (HIGH CHANNEL)

HORIZONTAL PEAK PLOT

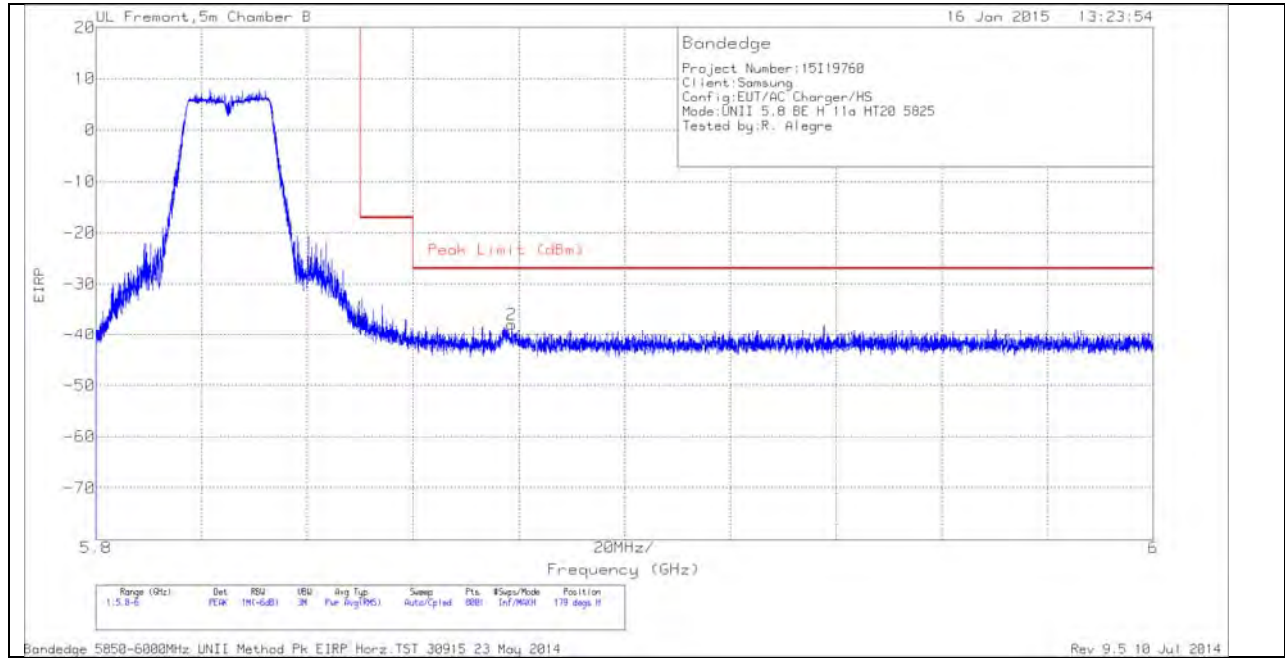

HORIZONTAL DATA

Marker	Frequency (GHz)	Meter Reading (dBm)	Det	AF T345 (dB/m)	Amp/Cb/F ltr/Pad (dB)	Conversion Factor (dB)	Corrected Reading EIRP	Peak Limit (dBm)	PK Margin (dB)	Azimuth (Degs)	Height (cm)	Polarity
1	5.85	-63.24	PK	34.8	-19.9	11.8	-36.54	-17	-19.54	179	211	H
2	5.879	-64.71	PK	34.9	-19.9	11.8	-37.91	-27	-10.91	179	211	H

VERTICAL PEAK PLOT

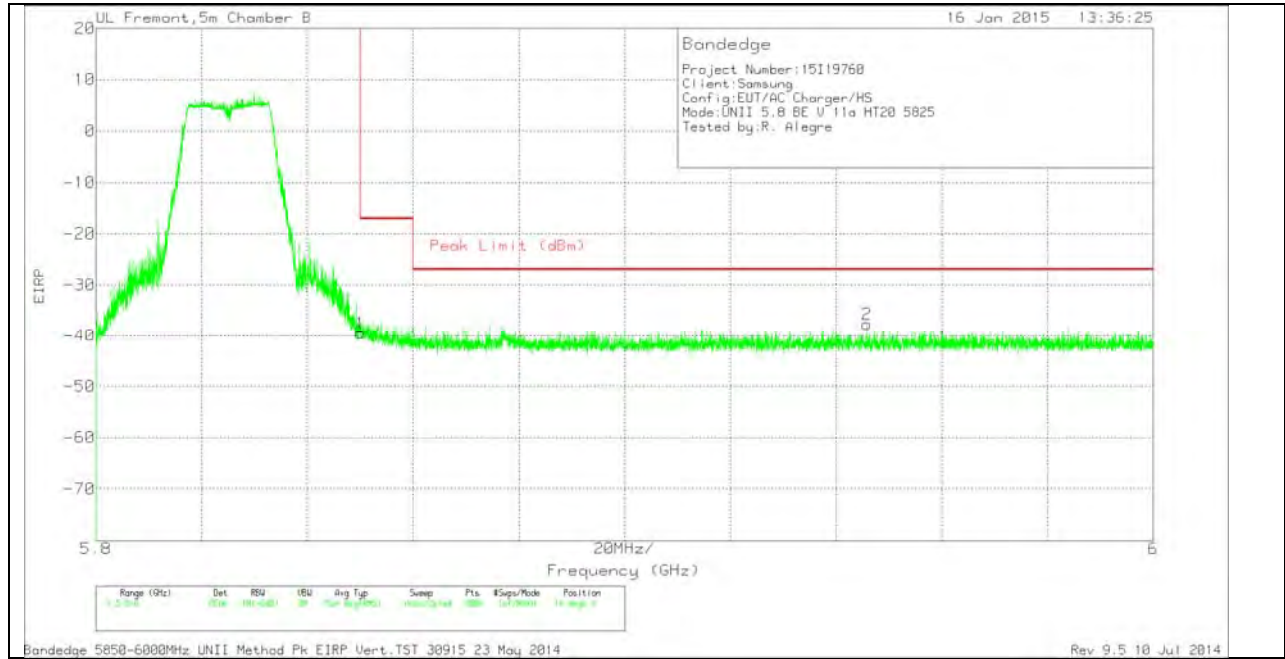

VERTICAL DATA

Marker	Frequency (GHz)	Meter Reading (dBm)	Det	AF T345 (dB/m)	Amp/Cbl/Filtr/Pad (dB)	Conversion Factor (dB)	DC Corr (dB)	Corrected Reading EIRP	Peak Limit (dBm)	PK Margin (dB)	Azimuth (Degs)	Height (cm)	Polarity
1	5.85	-66.23	PK	34.8	-19.9	11.8	0	-39.53	-17	-22.53	14	207	V
2	5.946	-65.06	PK	35.1	-19.5	11.8	0	-37.66	-27	-10.66	14	207	V

HARMONICS AND SPURIOUS EMISSIONS

LOW CHANNEL HORIZONTAL

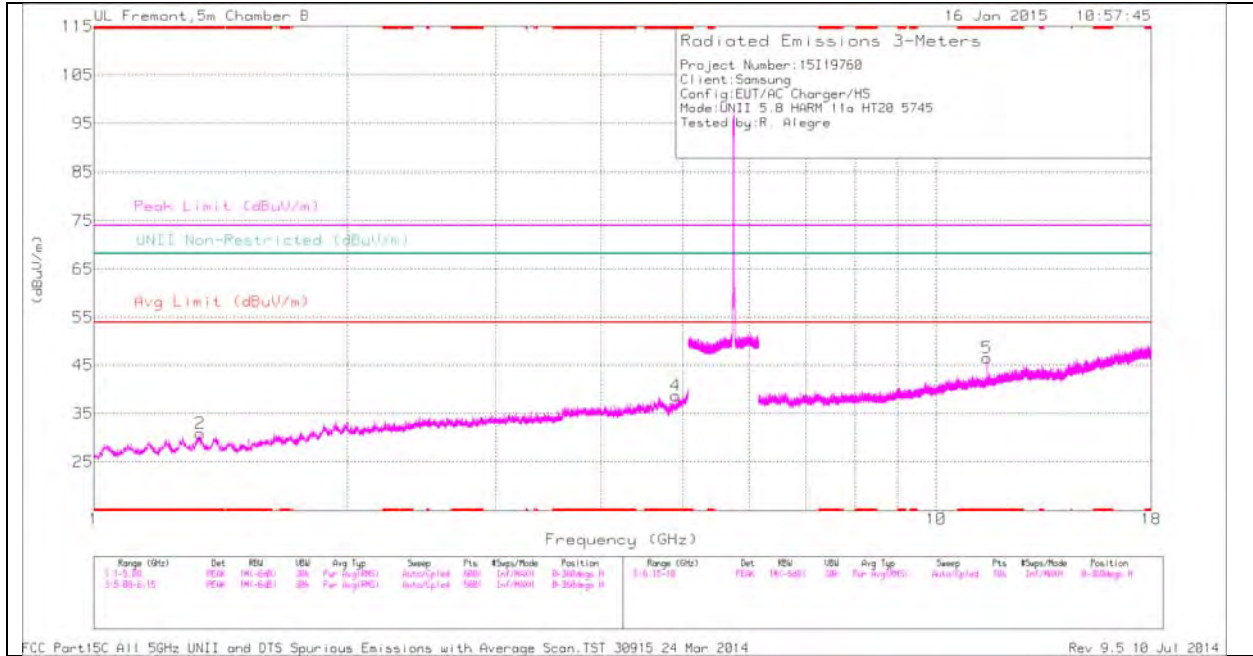

Note: Emission was scanned up to 40GHz; No emissions were detected above the noise floor which was at least 20dB below the specification limit.

LOW CHANNEL VERTICAL

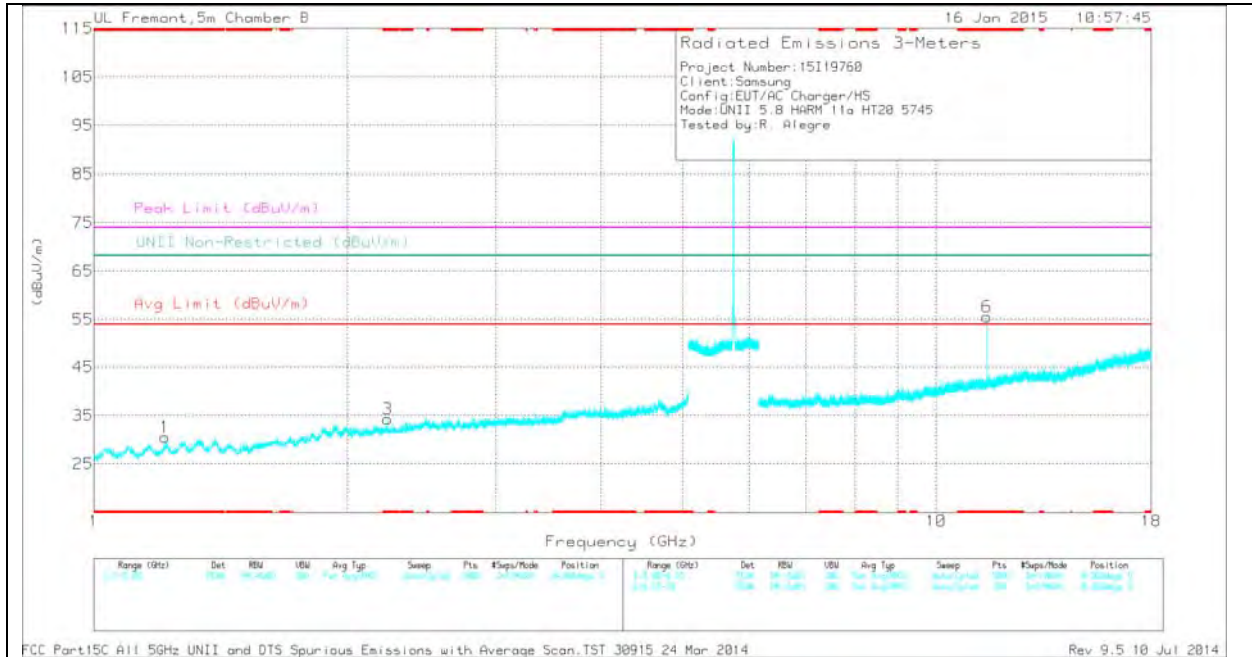

Note: Emission was scanned up to 40GHz; No emissions were detected above the noise floor which was at least 20dB below the specification limit.

LOW CHANNEL DATA

TRACE MARKERS

Marker	Frequency (GHz)	Meter Reading (dBuV)	Det	AF T345 (dB/m)	Amp/Cbl/Ftr/Pad (dB)	DC Corr (dB)	Corrected Reading (dBuV/m)	Avg Limit (dBuV/m)	Margin (dB)	Peak Limit (dBuV/m)	PK Margin (dB)	UNII Non-Restricted (dBuV/m)	PK Margin (dB)	Azimuth (Degs)	Height (cm)	Polarity
2	* 1.336	35.96	PK	28.7	-33.8	0	30.86	-	-	74	-43.14	-	-	0-360	199	H
4	* 4.903	34.15	PK	34.2	-29.7	0	38.65	-	-	74	-35.35	-	-	0-360	199	H
1	* 1.214	36.85	PK	28.3	-34.6	0	30.55	-	-	74	-43.45	-	-	0-360	101	V
3	* 2.231	35.35	PK	31.4	-32.5	0	34.25	-	-	74	-39.75	-	-	0-360	199	V
5	* 11.489	31.33	PK	38	-22.9	0	46.43	-	-	74	-27.57	-	-	0-360	200	H
6	* 11.49	40.42	PK	38	-22.9	0	55.52	-	-	74	-18.48	-	-	0-360	200	V

* - indicates frequency in CFR15.205/IC7.2.2 Restricted Band

PK - Peak detector

Radiated Emissions

Frequency (GHz)	Meter Reading (dBuV)	Det	AF T345 (dB/m)	Amp/Cbl/Ftr/Pad (dB)	DC Corr (dB)	Corrected Reading (dBuV/m)	Avg Limit (dBuV/m)	Margin (dB)	Peak Limit (dBuV/m)	PK Margin (dB)	UNII Non-Restricted (dBuV/m)	PK Margin (dB)	Azimuth (Degs)	Height (cm)	Polarity
* 11.49	42.16	PK1	38	-22.9	0	57.26	-	-	74	-16.74	-	-	120	201	V
* 11.49	38.5	AD1	38	-22.9	.32	53.9	54	-1	-	-	-	-	120	201	V

* - indicates frequency in CFR15.205/IC7.2.2 Restricted Band

PK1 - KDB789033 Method: Peak

AD1 - KDB789033 Method: AD Primary Power Average

MID CHANNEL HORIZONTAL

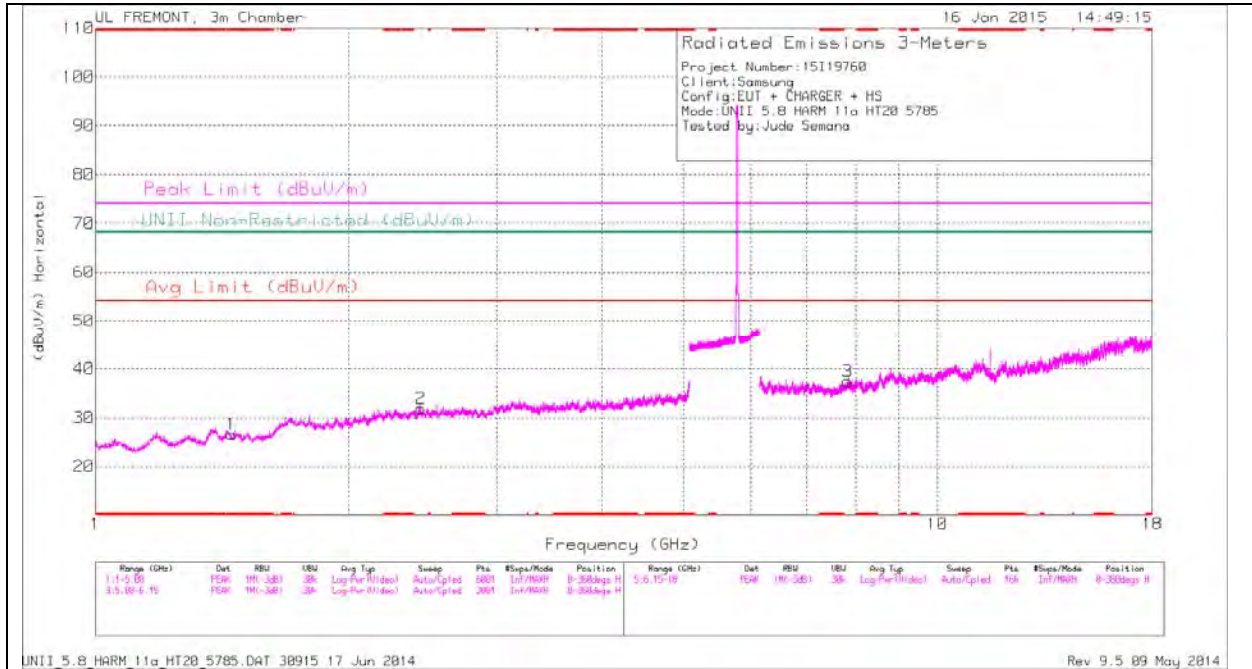

Note: Emission was scanned up to 40GHz; No emissions were detected above the noise floor which was at least 20dB below the specification limit.

MID CHANNEL VERTICAL

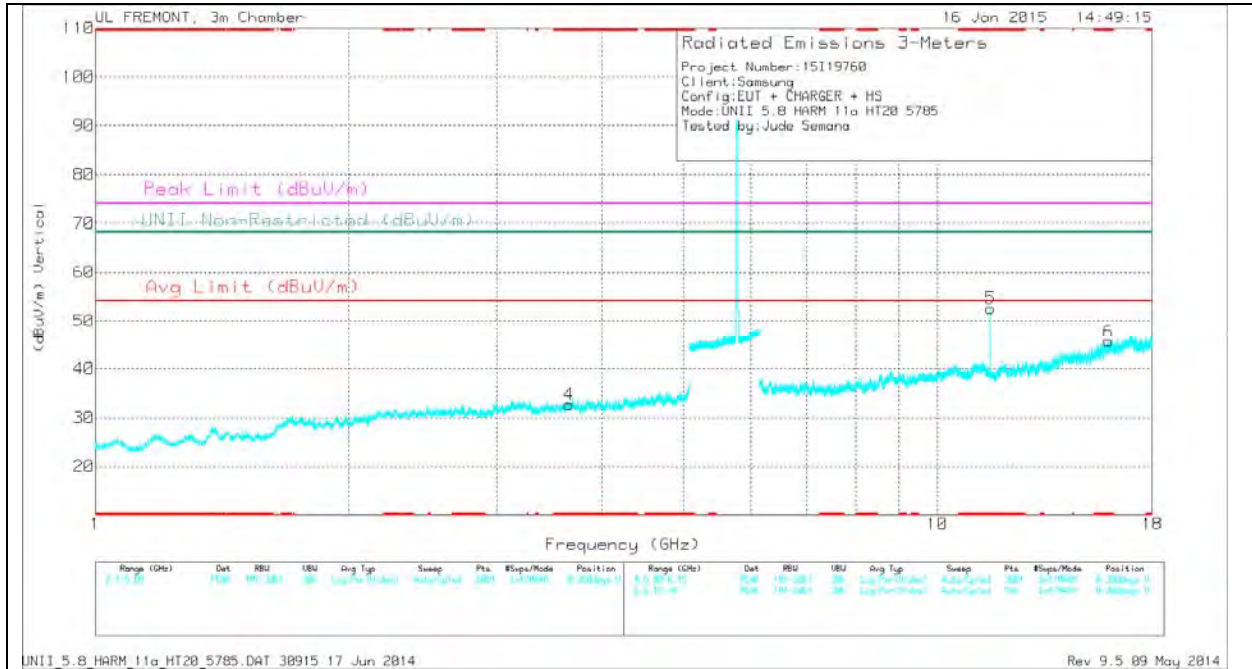

Note: Emission was scanned up to 40GHz; No emissions were detected above the noise floor which was at least 20dB below the specification limit.

MID CHANNEL DATA

TRACE MARKERS

Marker	Frequency (GHz)	Meter Reading (dBuV)	Det	AF T711 (dB/m)	Amp/Cbl/Ftr/Pad (dB)	DC Corr (dB)	Corrected Reading (dBuV/m)	Avg Limit (dBuV/m)	Margin (dB)	Peak Limit (dBuV/m)	PK Margin (dB)	UNII Non-Restricted (dBuV/m)	PK Margin (dB)	Azimuth (Degs)	Height (cm)	Polarity
1	* 1.452	31.29	PK	28	-32.7	0	26.59	-	-	74	-47.41	-	-	0-360	100	H
4	* 3.654	30.69	PK	33	-31	0	32.69	-	-	74	-41.31	-	-	0-360	200	V
5	* 11.57	40.58	PK	38.1	-26.1	0	52.58	-	-	74	-21.42	-	-	0-360	100	V
6	* 15.969	29.39	PK	41.9	-25.6	0	45.69	-	-	74	-28.31	-	-	0-360	100	V
2	2.436	32.28	PK	32.1	-32.5	0	31.88	-	-	-	-	68.2	-36.32	0-360	200	H
3	7.825	29.7	PK	35.8	-28.1	0	37.4	-	-	-	-	68.2	-30.8	0-360	200	H

* - indicates frequency in CFR15.205/IC7.2.2 Restricted Band

PK - Peak detector

Radiated Emissions

Frequency (GHz)	Meter Reading (dBuV)	Det	AF T711 (dB/m)	Amp/Cbl/Ftr/Pad (dB)	DC Corr (dB)	Corrected Reading (dBuV/m)	Avg Limit (dBuV/m)	Margin (dB)	Peak Limit (dBuV/m)	PK Margin (dB)	UNII Non-Restricted (dBuV/m)	PK Margin (dB)	Azimuth (Degs)	Height (cm)	Polarity
* 11.57	44.63	PK1	38.1	-26.1	0	56.63	-	-	74	-17.37	-	-	45	100	V
* 11.57	40.06	AD1	38.1	-26.1	.32	52.36	54	-1.64	-	-	-	-	45	100	V

* - indicates frequency in CFR15.205/IC7.2.2 Restricted Band

PK1 - KDB789033 Method: Peak

AD1 - KDB789033 Method: AD Primary Power Average

HIGH CHANNEL HORIZONTAL

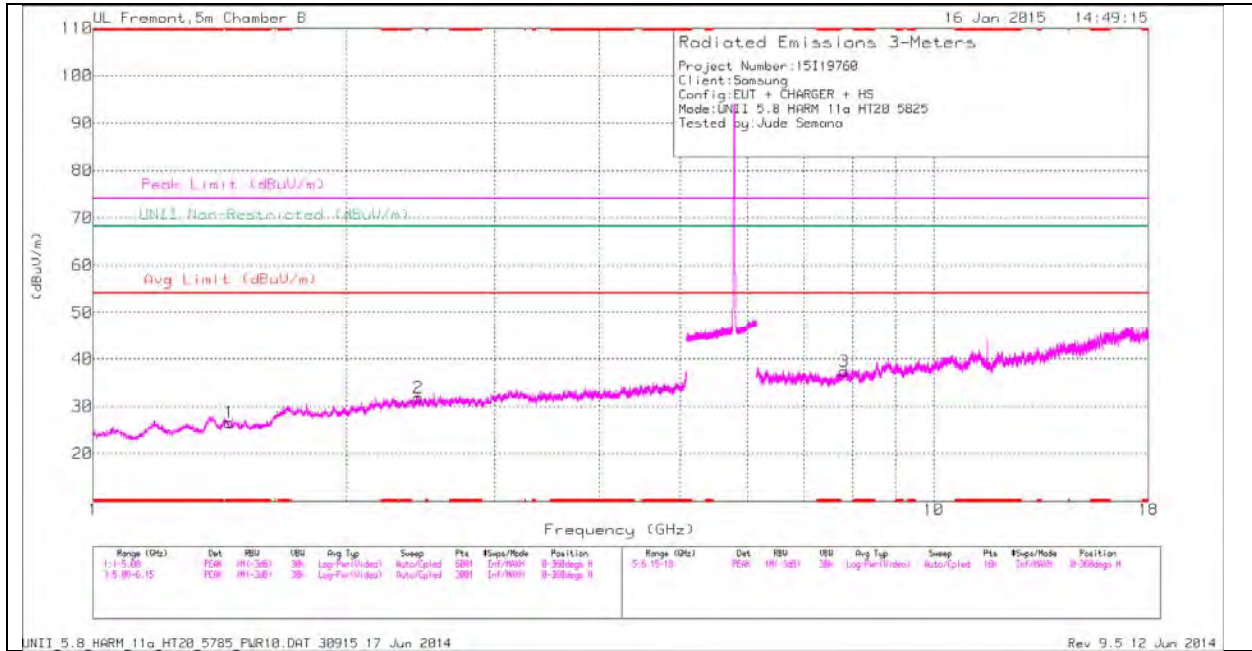

Note: Emission was scanned up to 40GHz; No emissions were detected above the noise floor which was at least 20dB below the specification limit.

HIGH CHANNEL VERTICAL

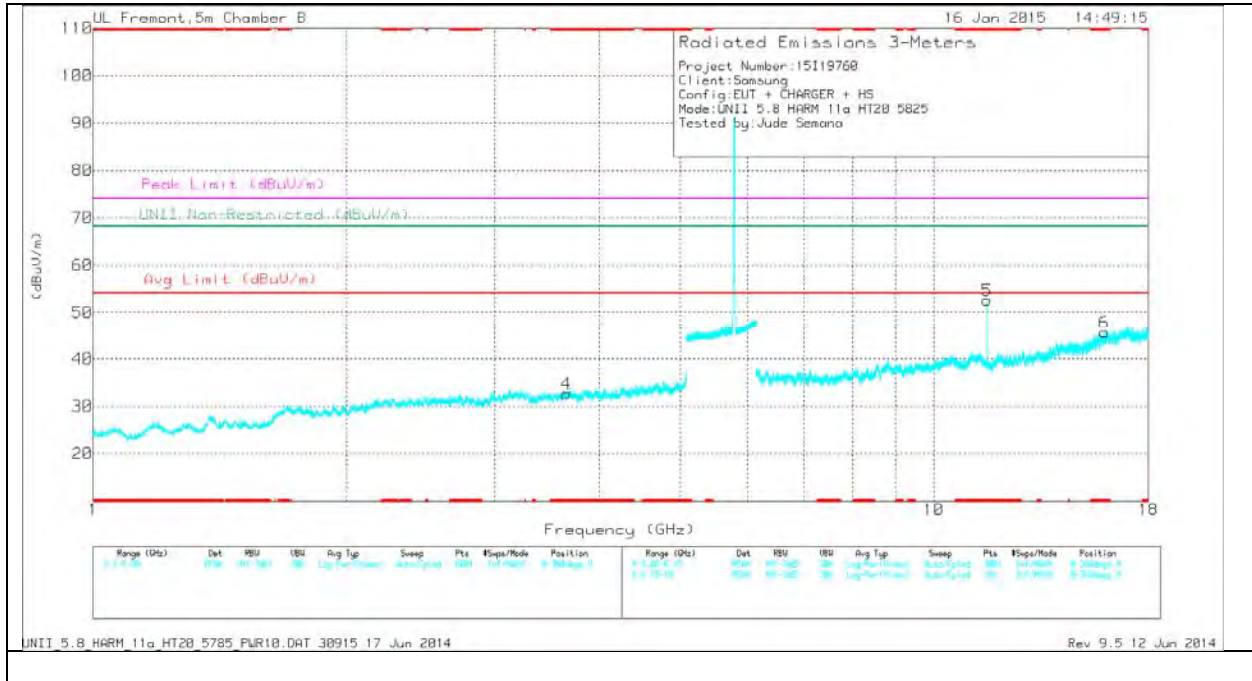

Note: Emission was scanned up to 40GHz; No emissions were detected above the noise floor which was at least 20dB below the specification limit.

HIGH CHANNEL DATA

TRACE MARKERS

Marker	Frequency (GHz)	Meter Reading (dBuV)	Det	AF T711 (dB/m)	Amp/Cbl/Ftr/Pad (dB)	DC Corr (dB)	Corrected Reading (dBuV/m)	Avg Limit (dBuV/m)	Margin (dB)	Peak Limit (dBuV/m)	PK Margin (dB)	UNII Non-Restricted (dBuV/m)	PK Margin (dB)	Azimuth (Degs)	Height (cm)	Polarity
1	* 1.452	31.29	PK	28	-32.7	0	26.59	-	-	74	-47.41	-	-	0-360	100	H
4	* 3.654	30.69	PK	33	-31	0	32.69	-	-	74	-41.31	-	-	0-360	200	V
5	* 11.57	40.58	PK	38.1	-26.1	0	52.58	-	-	74	-21.42	-	-	0-360	100	V
6	* 15.969	29.39	PK	41.9	-25.6	0	45.69	-	-	74	-28.31	-	-	0-360	100	V
2	2.436	32.28	PK	32.1	-32.5	0	31.88	-	-	-	-	68.2	-36.32	0-360	200	H
3	7.825	29.7	PK	35.8	-28.1	0	37.4	-	-	-	-	68.2	-30.8	0-360	200	H

* - indicates frequency in CFR15.205/IC7.2.2 Restricted Band

PK - Peak detector

Radiated Emissions

Frequency (GHz)	Meter Reading (dBuV)	Det	AF T711 (dB/m)	Amp/Cbl/Ftr/Pad (dB)	DC Corr (dB)	Corrected Reading (dBuV/m)	Avg Limit (dBuV/m)	Margin (dB)	Peak Limit (dBuV/m)	PK Margin (dB)	UNII Non-Restricted (dBuV/m)	PK Margin (dB)	Azimuth (Degs)	Height (cm)	Polarity
* 11.57	44.63	PK1	38.1	-26.1	0	56.63	-	-	74	-17.37	-	-	45	100	V
* 11.57	40.06	AD1	38.1	-26.1	.32	52.36	54	-1.64	-	-	-	-	45	100	V
* 11.57	43.74	PK1	38.1	-26.1	0	55.74	-	-	74	-18.26	-	-	52	319	V
* 11.57	39.33	AD1	38.1	-26.1	.32	51.63	54	-2.37	-	-	-	-	52	319	V

* - indicates frequency in CFR15.205/IC7.2.2 Restricted Band

PK1 - KDB789033 Method: Peak

AD1 - KDB789033 Method: AD Primary Power Average

11.4.2. TX ABOVE 1 GHz 802.11n HT20 MODE IN THE 5.8 GHz BAND

AUTHORIZED BANDEDGE (LOW CHANNEL)

HORIZONTAL PEAK PLOT

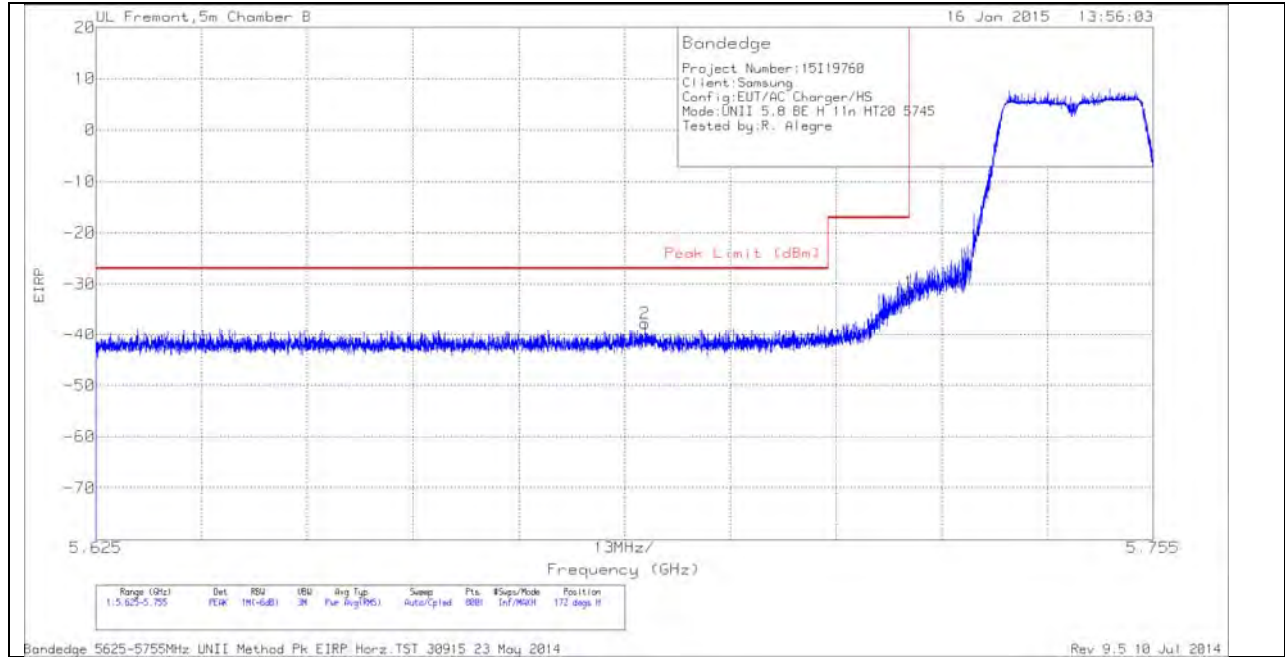

HORIZONTAL DATA

Marker	Frequency (GHz)	Meter Reading (dBm)	Det	AF T345 (dB/m)	Amp/Cbl/F ltr/Pad (dB)	Conversion Factor (dB)	Corrected Reading EIRP	Peak Limit (dBm)	PK Margin (dB)	Azimuth (Degs)	Height (cm)	Polarity
2	5.692	-63.83	PK	34.5	-20.2	11.8	-37.73	-27	-10.73	172	237	H
1	5.725	-58	PK	34.6	-20.1	11.8	-31.7	-17	-14.7	172	237	H

AUTHORIZED BANDEDGE (HIGH CHANNEL)

HORIZONTAL PEAK PLOT

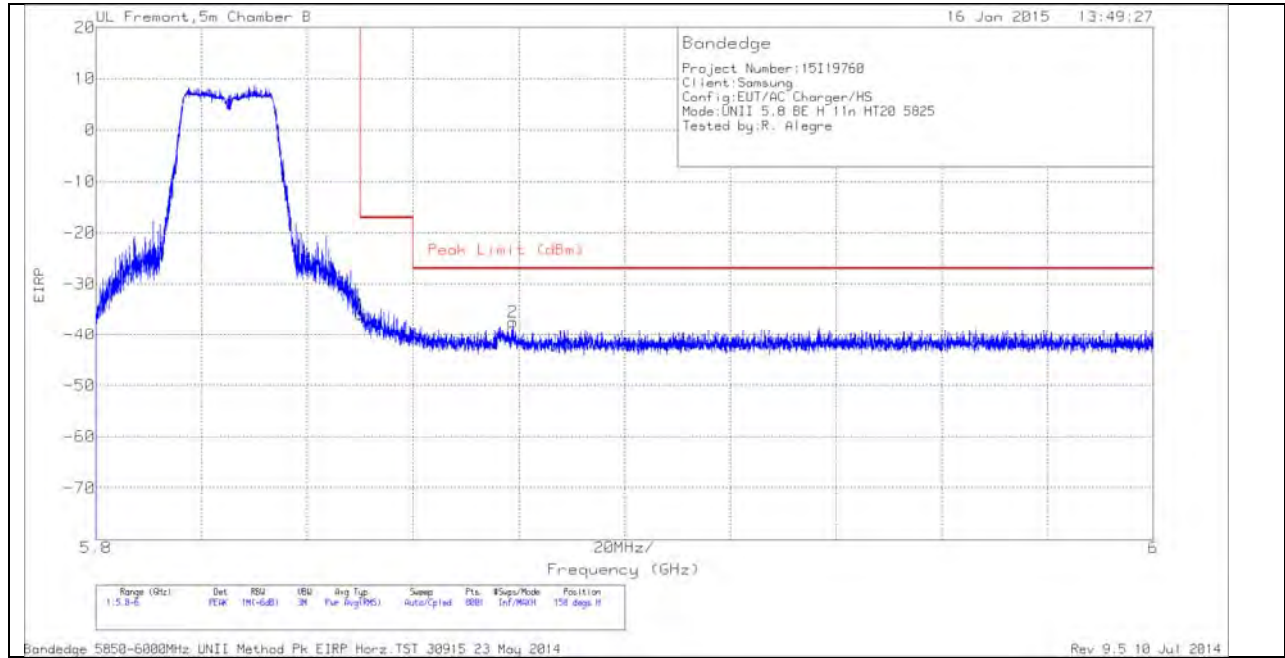

HORIZONTAL DATA

Marker	Frequency (GHz)	Meter Reading (dBm)	Det	AF T345 (dB/m)	Amp/Cbl/F ltr/Pad (dB)	Conversion Factor (dB)	Corrected Reading EIRP	Peak Limit (dBm)	PK Margin (dB)	Azimuth (Degs)	Height (cm)	Polarity
1	5.85	-62.66	PK	34.8	-19.9	11.8	-35.96	-17	-18.96	158	212	H
2	5.879	-64.2	PK	34.9	-19.9	11.8	-37.4	-27	-10.4	158	212	H

VERTICAL PEAK PLOT

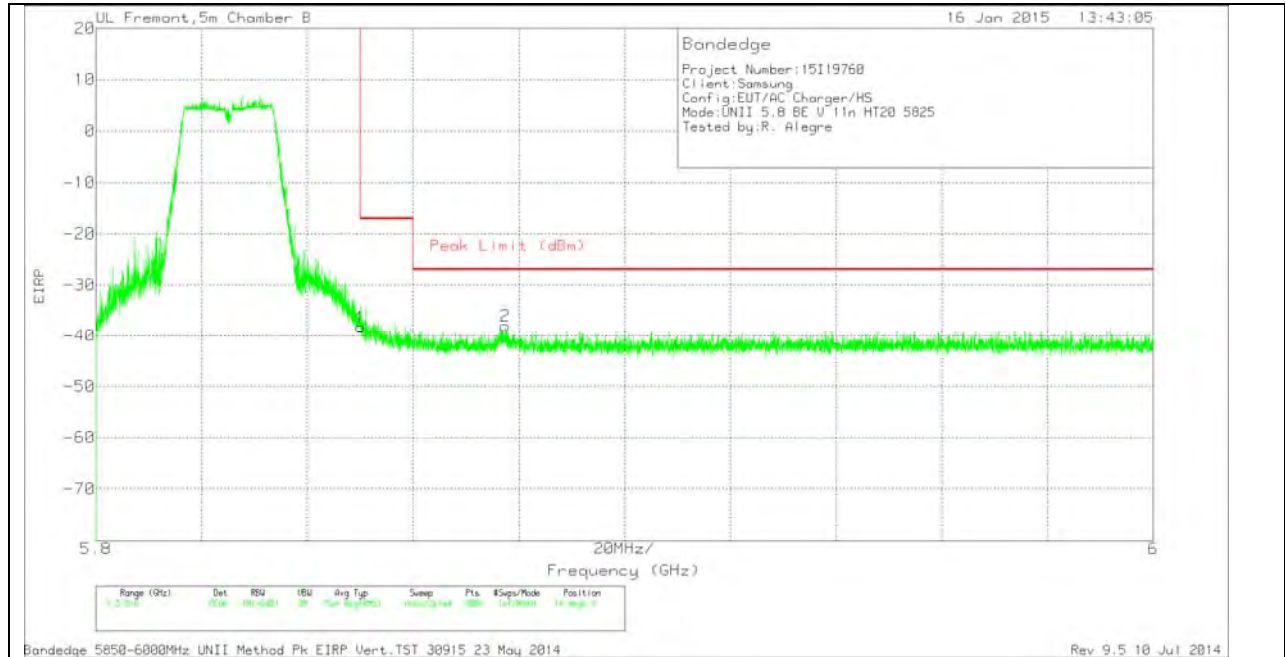

VERTICAL DATA

Marker	Frequency (GHz)	Meter Reading (dBm)	Det	AF T345 (dB/m)	Amp/Cbl/Filtr/Pad (dB)	Conversion Factor (dB)	DC Corr (dB)	Corrected Reading EIRP	Peak Limit (dBm)	PK Margin (dB)	Azimuth (Degs)	Height (cm)	Polarity
1	5.85	-65.02	PK	34.8	-19.9	11.8	0	-38.32	-17	-21.32	14	207	V
2	5.877	-64.87	PK	34.9	-19.9	11.8	0	-38.07	-27	-11.07	14	207	V

HARMONICS AND SPURIOUS EMISSIONS

LOW CHANNEL HORIZONTAL

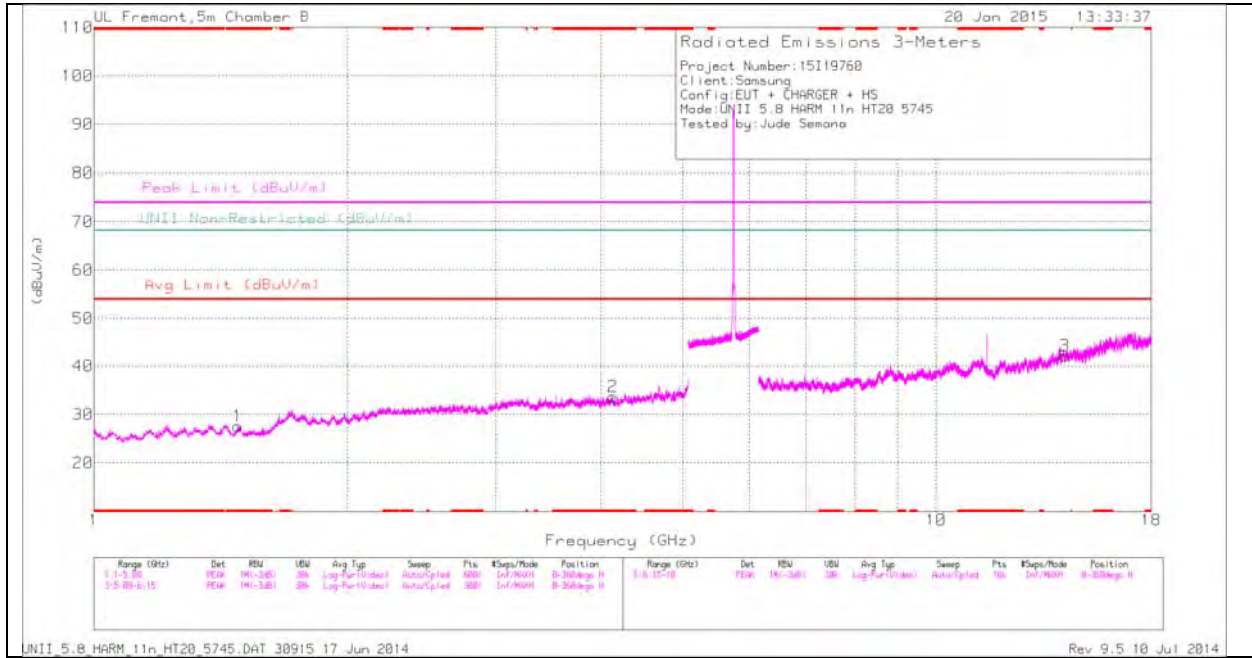

Note: Emission was scanned up to 40GHz; No emissions were detected above the noise floor which was at least 20dB below the specification limit.

LOW CHANNEL VERTICAL

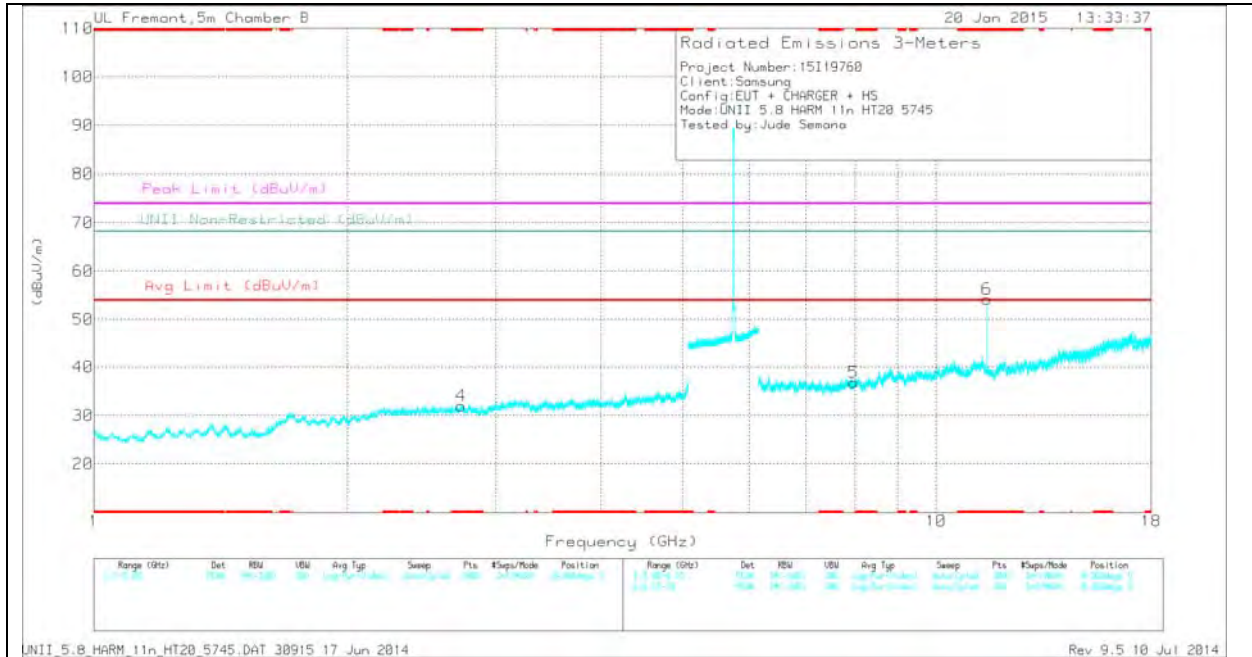

Note: Emission was scanned up to 40GHz; No emissions were detected above the noise floor which was at least 20dB below the specification limit.

LOW CHANNEL DATA

TRACE MARKERS

Marker	Frequency (GHz)	Meter Reading (dBuV)	Det	AF T711 (dB/m)	Amp/Cbl/Ftr/Pad (dB)	DC Corr (dB)	Corrected Reading (dBuV/m)	Avg Limit (dBuV/m)	Margin (dB)	Peak Limit (dBuV/m)	PK Margin (dB)	UNII Non-Restricted (dBuV/m)	PK Margin (dB)	Azimuth (Degs)	Height (cm)	Polarity
1	* 1.483	32.59	PK	27.8	-32.8	0	27.59	-	-	74	-46.41	-	-	0-360	100	H
2	* 4.13	31.65	PK	33.2	-31.2	0	33.65	-	-	74	-40.35	-	-	0-360	200	H
4	* 2.73	31.85	PK	32.4	-32.2	0	32.05	-	-	74	-41.95	-	-	0-360	100	V
6	* 11.49	42.07	PK	38.1	-26	0	54.17	-	-	74	-19.83	-	-	0-360	100	V
5	7.982	29.48	PK	35.9	-28.6	0	36.78	-	-	-	-	68.2	-31.42	0-360	100	V
3	14.206	29.53	PK	39.7	-27.1	0	42.13	-	-	-	-	68.2	-26.07	0-360	200	H

* - indicates frequency in CFR15.205/IC7.2.2 Restricted Band

PK - Peak detector

Radiated Emissions

Frequency (GHz)	Meter Reading (dBuV)	Det	AF T711 (dB/m)	Amp/Cbl/Ftr/Pad (dB)	DC Corr (dB)	Corrected Reading (dBuV/m)	Avg Limit (dBuV/m)	Margin (dB)	Peak Limit (dBuV/m)	PK Margin (dB)	UNII Non-Restricted (dBuV/m)	PK Margin (dB)	Azimuth (Degs)	Height (cm)	Polarity
* 11.49	42.98	PK1	38.1	-26	0	55.08	-	-	74	-18.92	-	-	303	227	V
* 11.49	39.79	AD1	38.1	-26	.32	52.19	54	-1.81	-	-	-	-	303	227	V

* - indicates frequency in CFR15.205/IC7.2.2 Restricted Band

PK1 - KDB789033 Method: Peak

AD1 - KDB789033 Method: AD Primary Power Average

MID CHANNEL HORIZONTAL

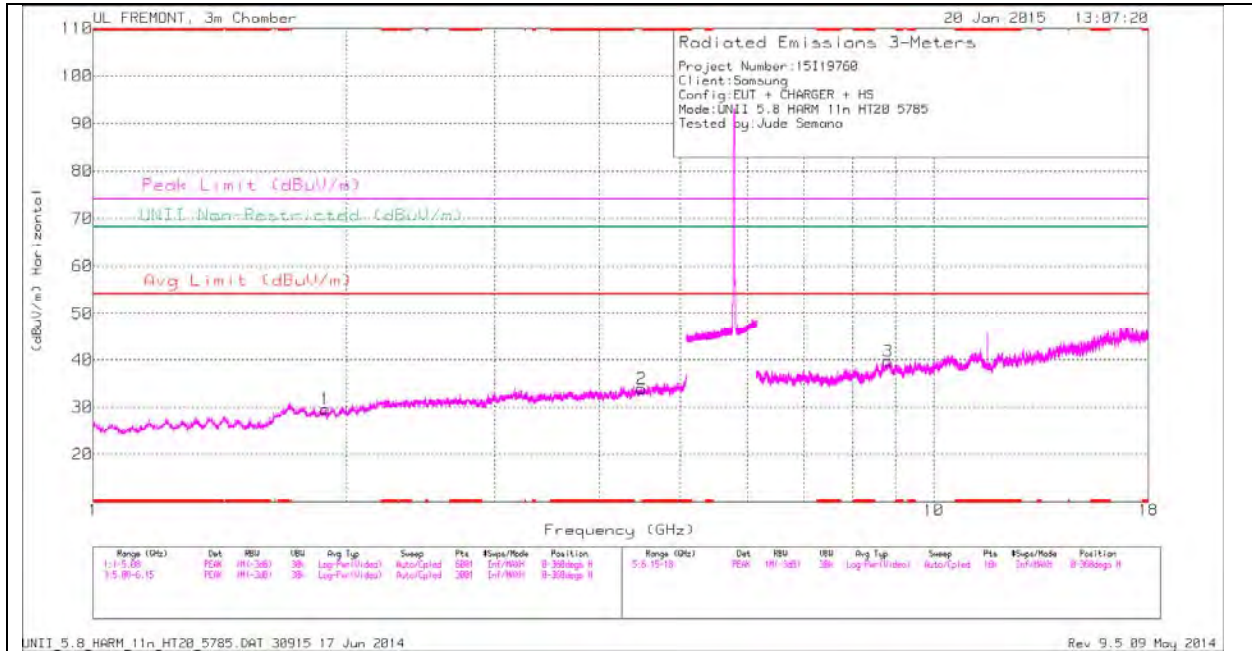

Note: Emission was scanned up to 40GHz; No emissions were detected above the noise floor which was at least 20dB below the specification limit.

MID CHANNEL VERTICAL

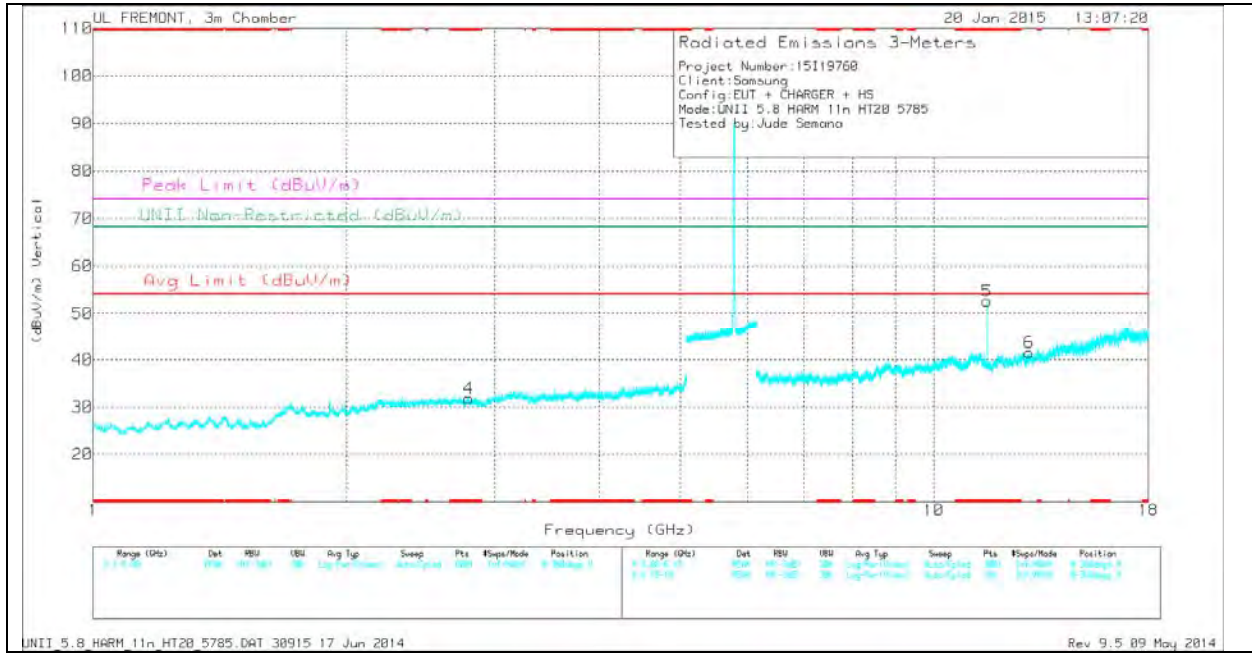

Note: Emission was scanned up to 40GHz; No emissions were detected above the noise floor which was at least 20dB below the specification limit.

MID CHANNEL DATA

TRACE MARKERS

Marker	Frequency (GHz)	Meter Reading (dBuV)	Det	AF T711 (dB/m)	Amp/Cbl/Ftr/Pad (dB)	DC Corr (dB)	Corrected Reading (dBuV/m)	Avg Limit (dBuV/m)	Margin (dB)	Peak Limit (dBuV/m)	PK Margin (dB)	UNII Non-Restricted (dBuV/m)	PK Margin (dB)	Azimuth (Degs)	Height (cm)	Polarity
4	* 2.797	31.88	PK	32.4	-32.4	0	31.88	-	-	74	-42.12	-	-	0-360	200	V
5	* 11.57	40.6	PK	38.1	-26.1	0	52.6	-	-	74	-21.4	-	-	0-360	100	V
1	1.889	32.33	PK	30.3	-33	0	29.63	-	-	-	-	68.2	-38.57	0-360	200	H
2	4.492	31.22	PK	33.6	-30.9	0	33.92	-	-	-	-	68.2	-34.28	0-360	100	H
3	8.821	28.82	PK	36.6	-25.7	0	39.72	-	-	-	-	68.2	-28.48	0-360	100	H
6	12.986	29.85	PK	38.8	-27.1	0	41.55	-	-	-	-	68.2	-26.65	0-360	200	V

* - indicates frequency in CFR15.205/IC7.2.2 Restricted Band

PK - Peak detector

Radiated Emissions

Frequency (GHz)	Meter Reading (dBuV)	Det	AF T711 (dB/m)	Amp/Cbl/Ftr/Pad (dB)	DC Corr (dB)	Corrected Reading (dBuV/m)	Avg Limit (dBuV/m)	Margin (dB)	Peak Limit (dBuV/m)	PK Margin (dB)	UNII Non-Restricted (dBuV/m)	PK Margin (dB)	Azimuth (Degs)	Height (cm)	Polarity
* 11.57	45.27	PK1	38.1	-26.1	0	57.27	-	-	74	-16.73	-	-	45	265	V
* 11.57	41.32	AD1	38.1	-26.1	.33	53.62	54	-38	-	-	-	-	45	265	V

* - indicates frequency in CFR15.205/IC7.2.2 Restricted Band

PK1 - KDB789033 Method: Peak

AD1 - KDB789033 Method: AD Primary Power Average

HIGH CHANNEL HORIZONTAL

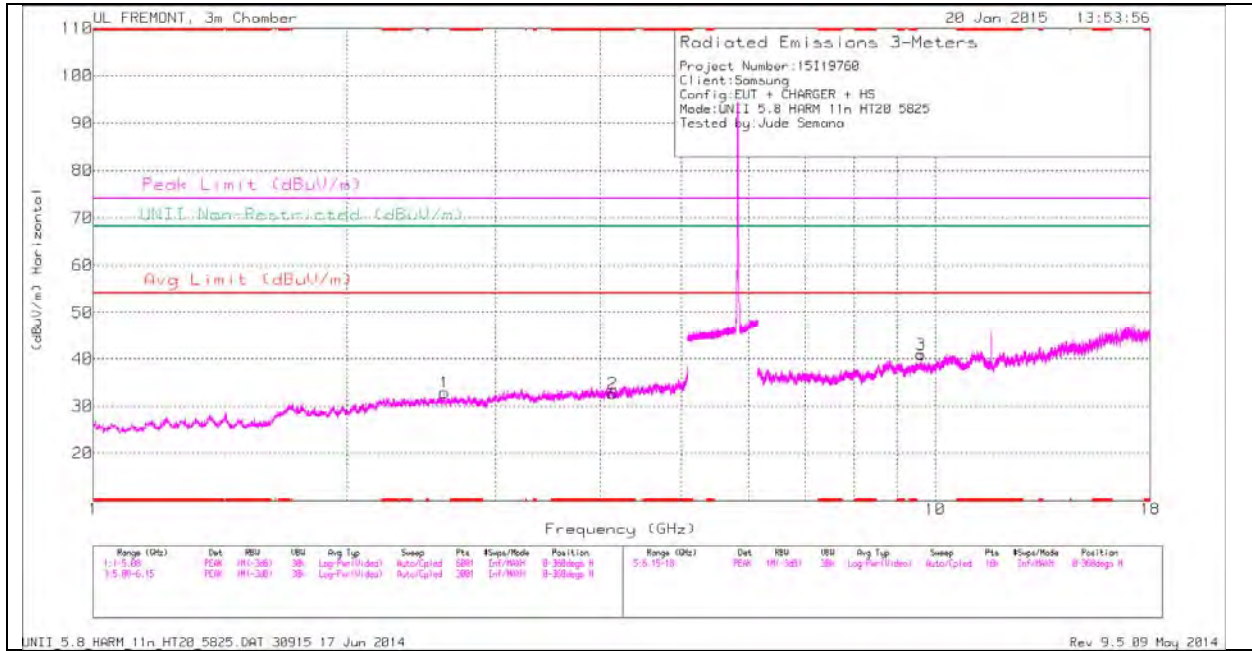

Note: Emission was scanned up to 40GHz; No emissions were detected above the noise floor which was at least 20dB below the specification limit.

HIGH CHANNEL VERTICAL

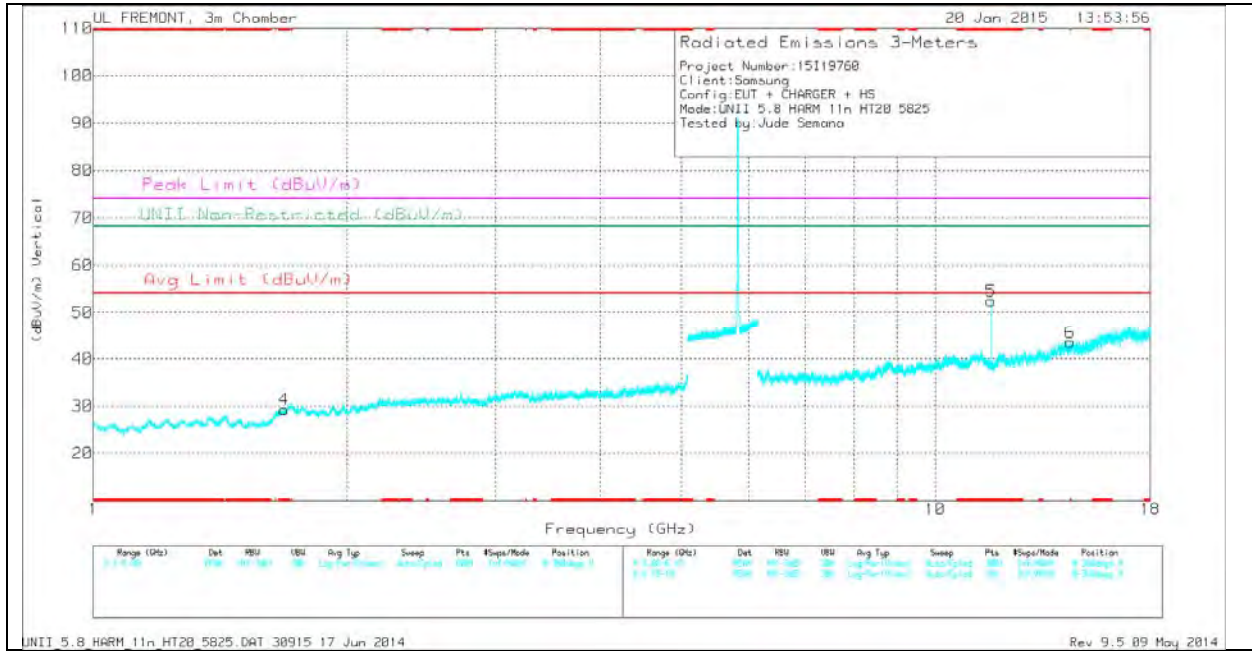

Note: Emission was scanned up to 40GHz; No emissions were detected above the noise floor which was at least 20dB below the specification limit.

HIGH CHANNEL DATA

TRACE MARKERS

Marker	Frequency (GHz)	Meter Reading (dBuV)	Det	AF T711 (dB/m)	Amp/Cbl/Ftr/Pad (dB)	DC Corr (dB)	Corrected Reading (dBuV/m)	Avg Limit (dBuV/m)	Margin (dB)	Peak Limit (dBuV/m)	PK Margin (dB)	UNII Non-Restricted (dBuV/m)	PK Margin (dB)	Azimuth (Degs)	Height (cm)	Polarity
2	* 4.135	30.75	PK	33.2	-31.3	0	32.65	-	-	74	-41.35	-	-	0-360	200	H
4	* 1.685	31.5	PK	30.2	-32.4	0	29.3	-	-	74	-44.7	-	-	0-360	100	V
5	* 11.65	40.4	PK	38.2	-26.2	0	52.4	-	-	74	-21.6	-	-	0-360	100	V
1	2.612	32.99	PK	32.3	-32.4	0	32.89	-	-	-	-	68.2	-35.31	0-360	200	H
3	9.616	29.05	PK	37.1	-25.2	0	40.95	-	-	-	-	68.2	-27.25	0-360	100	H
6	14.453	30.88	PK	40	-27.4	0	43.48	-	-	-	-	68.2	-24.72	0-360	200	V

* - indicates frequency in CFR15.205/IC7.2.2 Restricted Band

PK - Peak detector

Radiated Emissions

Frequency (GHz)	Meter Reading (dBuV)	Det	AF T711 (dB/m)	Amp/Cbl/Ftr/Pad (dB)	DC Corr (dB)	Corrected Reading (dBuV/m)	Avg Limit (dBuV/m)	Margin (dB)	Peak Limit (dBuV/m)	PK Margin (dB)	UNII Non-Restricted (dBuV/m)	PK Margin (dB)	Azimuth (Degs)	Height (cm)	Polarity
* 11.65	44.93	PK1	38.2	-26.2	0	56.93	-	-	74	-17.07	-	-	206	100	V
* 11.65	41.34	AD1	38.2	-26.2	.33	53.64	54	-36	-	-	-	-	206	100	V

* - indicates frequency in CFR15.205/IC7.2.2 Restricted Band

PK1 - KDB789033 Method: Peak

AD1 - KDB789033 Method: AD Primary Power Average

11.4.3. TX ABOVE 1 GHz 802.11n HT40 MODE IN THE 5.8 GHz BAND

AUTHORIZED BANDEDGE (LOW CHANNEL)

HORIZONTAL PEAK PLOT

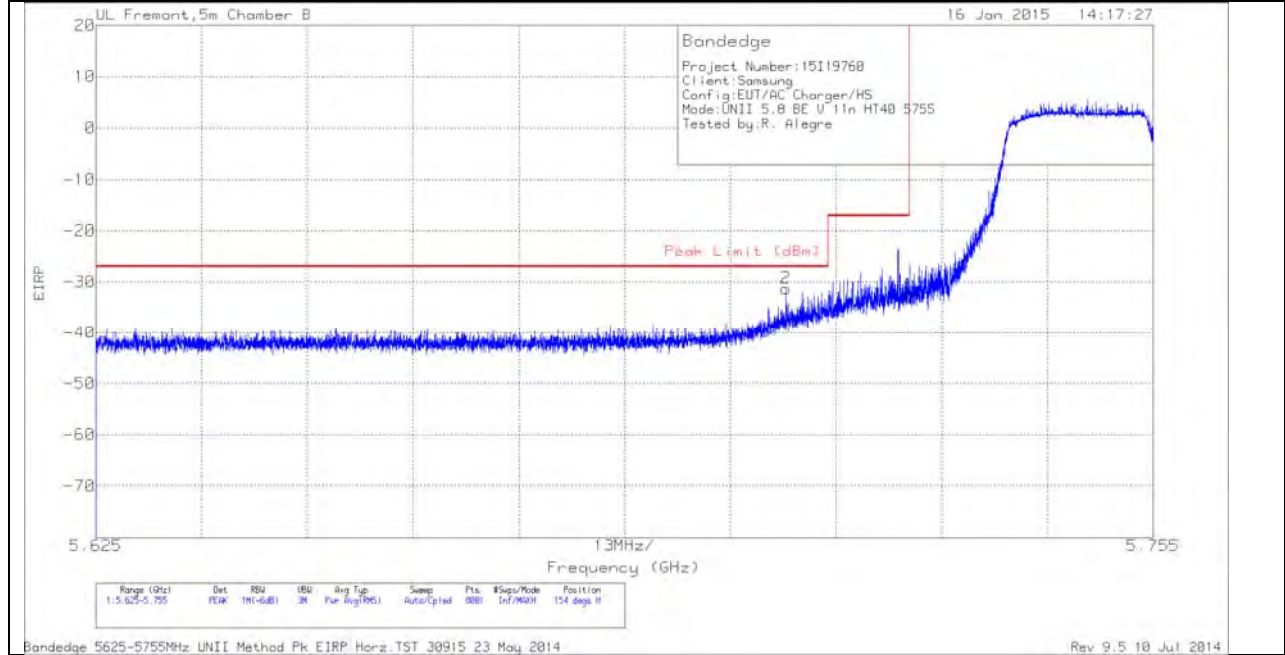

HORIZONTAL DATA

Marker	Frequency (GHz)	Meter Reading (dBm)	Det	AF T345 (dB/m)	Amp/Cbl/F ltr/Pad (dB)	Conversion Factor (dB)	Corrected Reading EIRP	Peak Limit (dBm)	PK Margin (dB)	Azimuth (Degs)	Height (cm)	Polarity
2	5.71	-57.44	PK	34.5	-20.1	11.8	-31.24	-27	-4.24	154	259	H
1	5.725	-58.77	PK	34.6	-20.1	11.8	-32.47	-17	-15.47	154	259	H

AUTHORIZED BANDEGE (HIGH CHANNEL)

HORIZONTAL PEAK PLOT

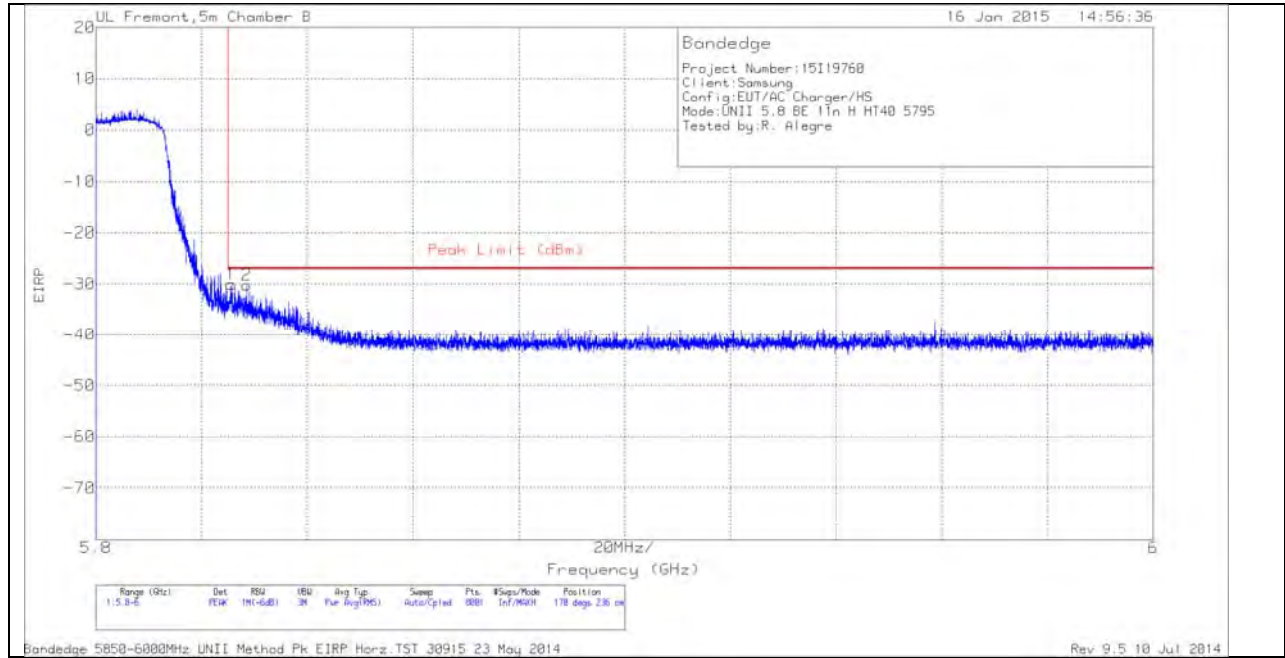

HORIZONTAL DATA

Marker	Frequency (GHz)	Meter Reading (dBm)	Det	AF T345 (dB/m)	Amp/Cb/F ltr/Pad (dB)	Conversion Factor (dB)	Corrected Reading EIRP	Peak Limit (dBm)	PK Margin (dB)	Azimuth (Degs)	Height (cm)	Polarity
1	5.826	-56.62	PK	34.8	-20	11.8	-30.02	-27	-3.02	170	236	H
2	5.829	-56.9	PK	34.8	-19.9	11.8	-30.2	-27	-3.2	170	236	H

VERTICAL PEAK AND AVERAGE PLOT

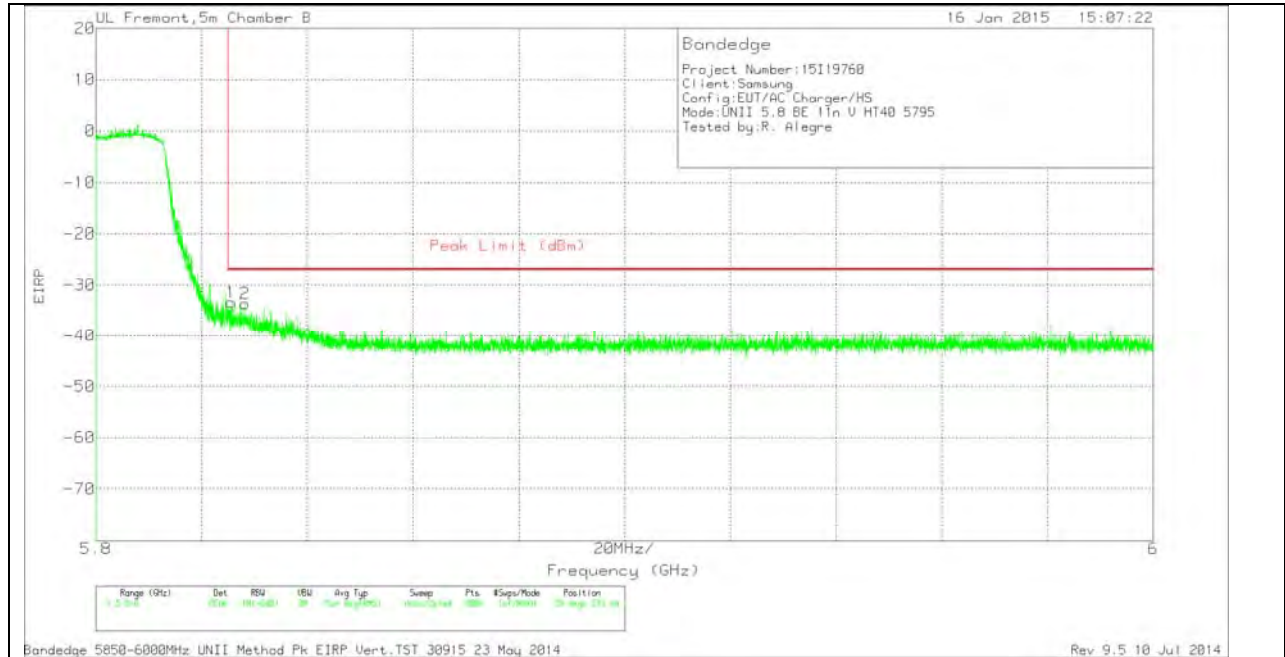

VERTICAL DATA

Marker	Frequency (GHz)	Meter Reading (dBm)	Det	AF T345 (dB/m)	Amp/Cbl/F ltr/Pad (dB)	Conversion Factor (dB)	Corrected Reading EIRP	Peak Limit (dBm)	PK Margin (dB)	Azimuth (Degs)	Height (cm)	Polarity
1	5.826	-59.97	PK	34.8	-20	11.8	-33.37	-27	-6.37	29	273	V
2	5.828	-60.39	PK	34.8	-19.9	11.8	-33.69	-27	-6.69	29	273	V

HARMONICS AND SPURIOUS EMISSIONS

LOW CHANNEL HORIZONTAL

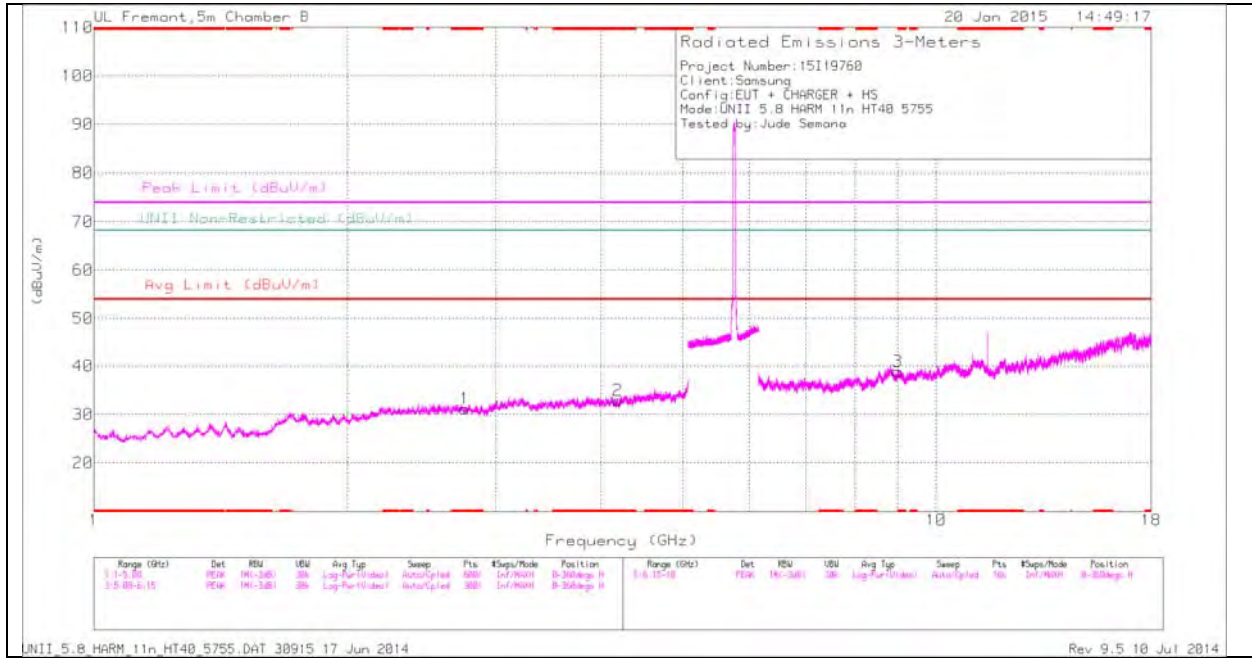

Note: Emission was scanned up to 40GHz; No emissions were detected above the noise floor which was at least 20dB below the specification limit.

LOW CHANNEL VERTICAL

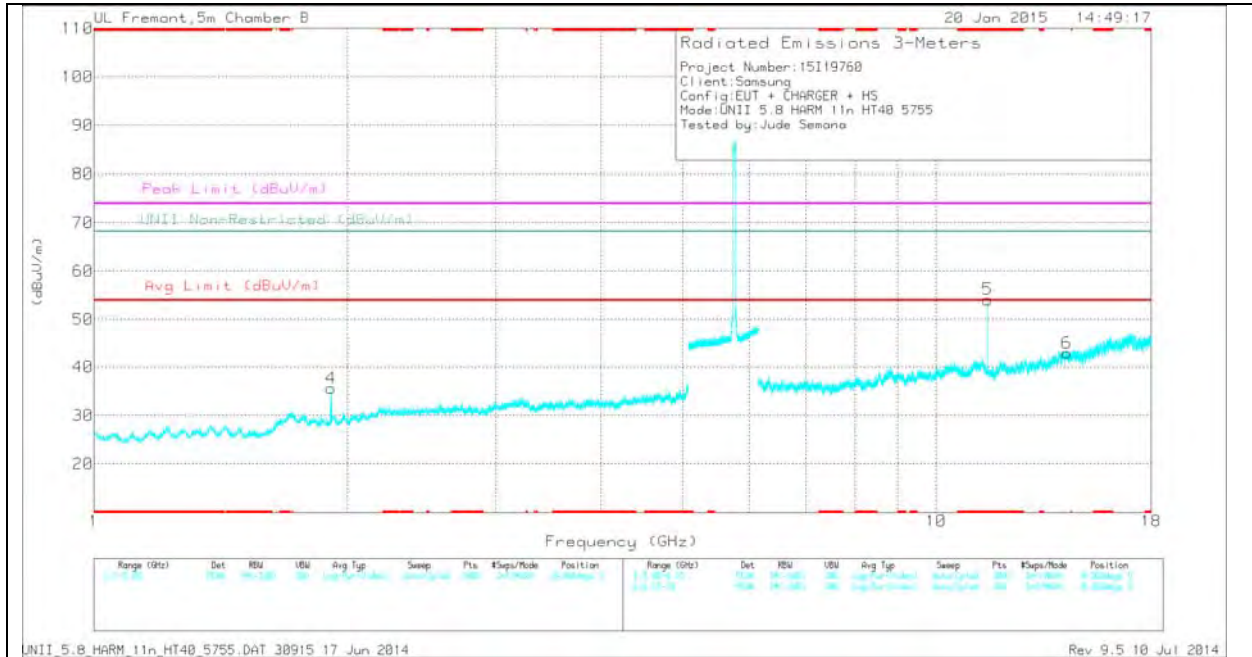

Note: Emission was scanned up to 40GHz; No emissions were detected above the noise floor which was at least 20dB below the specification limit.

LOW CHANNEL DATA

TRACE MARKERS

Marker	Frequency (GHz)	Meter Reading (dBuV)	Det	AF T711 (dB/m)	Amp/Cbl/Ftr/Pad (dB)	DC Corr (dB)	Corrected Reading (dBuV/m)	Avg Limit (dBuV/m)	Margin (dB)	Peak Limit (dBuV/m)	PK Margin (dB)	UNII Non-Restricted (dBuV/m)	PK Margin (dB)	Azimuth (Degs)	Height (cm)	Polarity
1	* 2.757	31.03	PK	32.4	-32.2	0	31.23	-	-	74	-42.77	-	-	0-360	200	H
2	* 4.185	31	PK	33.3	-31.4	0	32.9	-	-	74	-41.1	-	-	0-360	100	H
3	* 9.006	28.39	PK	36.6	-26.1	0	38.89	-	-	74	-35.11	-	-	0-360	200	H
5	* 11.51	42.24	PK	38.1	-26.2	0	54.14	-	-	74	-19.86	-	-	0-360	200	V
4	1.911	38.22	PK	30.2	-32.8	0	35.62	-	-	-	-	68.2	-32.58	0-360	100	V
6	14.301	30.24	PK	40	-27.3	0	42.94	-	-	-	-	68.2	-25.26	0-360	200	V

* - indicates frequency in CFR15.205/IC7.2.2 Restricted Band

PK - Peak detector

Radiated Emissions

Frequency (GHz)	Meter Reading (dBuV)	Det	AF T711 (dB/m)	Amp/Cbl/Ftr/Pad (dB)	DC Corr (dB)	Corrected Reading (dBuV/m)	Avg Limit (dBuV/m)	Margin (dB)	Peak Limit (dBuV/m)	PK Margin (dB)	UNII Non-Restricted (dBuV/m)	PK Margin (dB)	Azimuth (Degs)	Height (cm)	Polarity
* 11.51	42.58	PK1	38.1	-26.2	0	54.48	-	-	74	-19.52	-	-	118	202	V
* 11.51	38.99	AD1	38.1	-26.2	.64	51.54	54	-2.46	-	-	-	-	118	202	V
* 11.49	42.98	PK1	38.1	-26	0	55.08	-	-	74	-18.92	-	-	303	227	V
* 11.49	39.79	AD1	38.1	-26	.64	52.54	54	-1.46	-	-	-	-	303	227	V

* - indicates frequency in CFR15.205/IC7.2.2 Restricted Band

PK1 - KDB789033 Method: Peak

AD1 - KDB789033 Method: AD Primary Power Average

HIGH CHANNEL HORIZONTAL

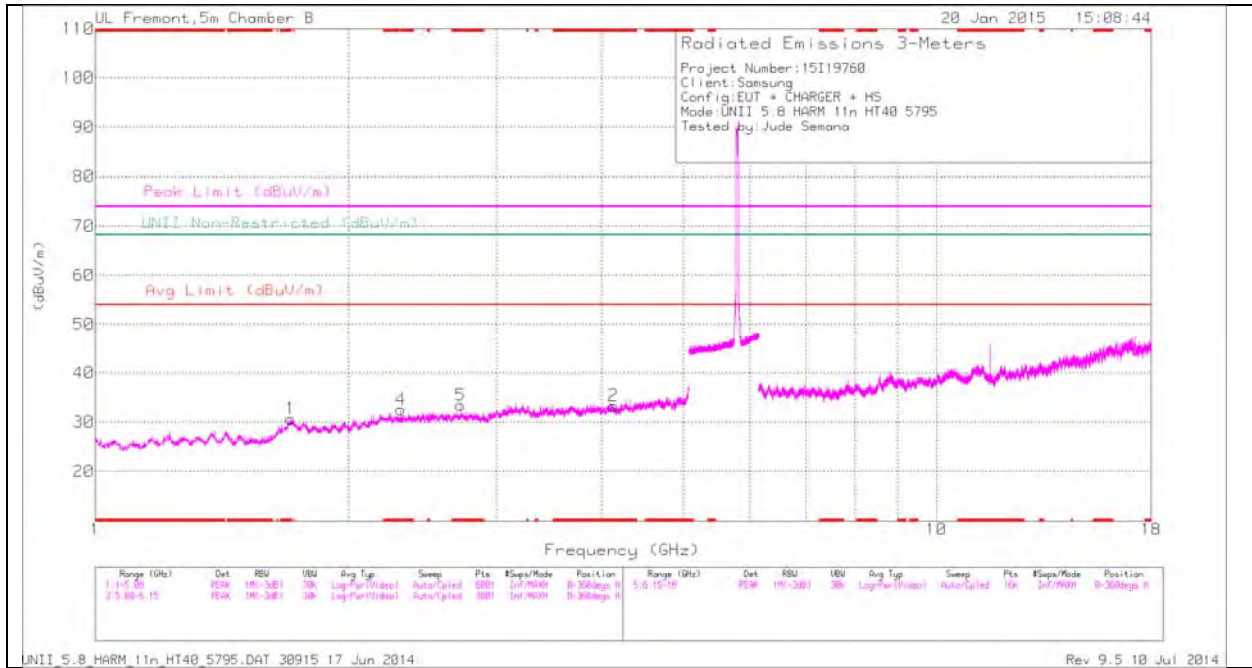

Note: Emission was scanned up to 40GHz; No emissions were detected above the noise floor which was at least 20dB below the specification limit.

HIGH CHANNEL VERTICAL

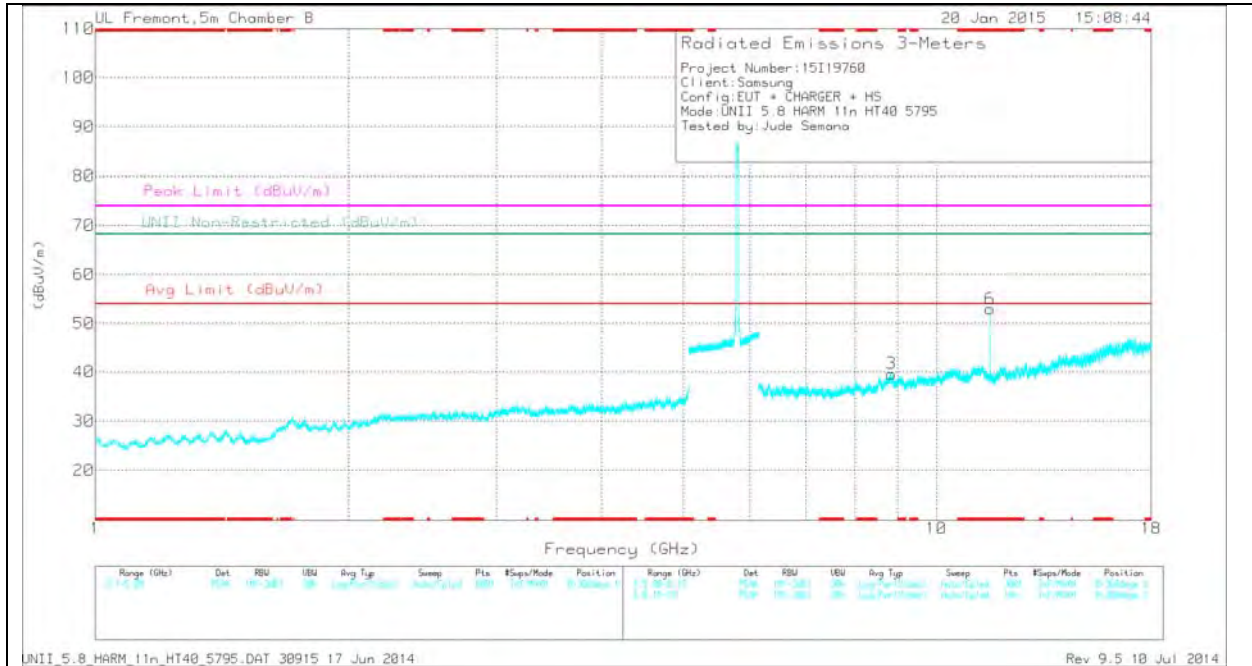

Note: Emission was scanned up to 40GHz; No emissions were detected above the noise floor which was at least 20dB below the specification limit.

HIGH CHANNEL DATA

TRACE MARKERS

Marker	Frequency (GHz)	Meter Reading (dBuV)	Det	AF T711 (dB/m)	Amp/Cb/ Ftr/Pad (dB)	DC Corr (dB)	Corrected Reading (dBuV/m)	Avg Limit (dBuV/m)	Margin (dB)	Peak Limit (dBuV/m)	PK Margin (dB)	UNII Non-Restricted (dBuV/m)	PK Margin (dB)	Azimuth (Degs)	Height (cm)	Polarity
1	* 1.709	32.1	PK	30.7	-32.1	0	30.7	-	-	74	-43.3	-	-	0-360	100	H
2	* 4.131	31.34	PK	33.2	-31.2	0	33.34	-	-	74	-40.66	-	-	0-360	200	H
5	* 2.719	33.22	PK	32.4	-32.2	0	33.42	-	-	74	-40.58	-	-	0-360	200	H
6	* 11.59	40.8	PK	38.1	-25.9	0	53	-	-	74	-21	-	-	0-360	100	V
4	2.308	33.26	PK	31.9	-32.6	0	32.56	-	-	-	-	68.2	-35.64	0-360	200	H
3	8.838	29.24	PK	36.6	-26.2	0	39.64	-	-	-	-	68.2	-28.56	0-360	100	V

* - indicates frequency in CFR15.205/IC7.2.2 Restricted Band

PK - Peak detector

Radiated Emissions

Frequency (GHz)	Meter Reading (dBuV)	Det	AF T711 (dB/m)	Amp/Cb/ Ftr/Pad (dB)	DC Corr (dB)	Corrected Reading (dBuV/m)	Avg Limit (dBuV/m)	Margin (dB)	Peak Limit (dBuV/m)	PK Margin (dB)	UNII Non-Restricted (dBuV/m)	PK Margin (dB)	Azimuth (Degs)	Height (cm)	Polarity
* 11.59	42.97	PK1	38.1	-25.9	0	55.17	-	-	74	-18.83	-	-	304	244	H
* 11.59	28.48	AD1	38.1	-25.9	.64	41.33	54	-12.67	-	-	-	-	304	244	H
* 11.59	37.11	PK1	38.1	-25.9	0	49.31	-	-	74	-24.69	-	-	304	244	H
* 11.59	28.55	AD1	38.1	-25.9	.64	41.4	54	-12.6	-	-	-	-	304	244	H

* - indicates frequency in CFR15.205/IC7.2.2 Restricted Band

PK1 - KDB789033 Method: Peak

AD1 - KDB789033 Method: AD Primary Power Average

12. WORST-CASE BELOW 1 GHz (in the 5.3 GHz Band)

SPURIOUS EMISSIONS 30 TO 1000 MHz (WORST-CASE CONFIGURATION, HORIZONTAL)

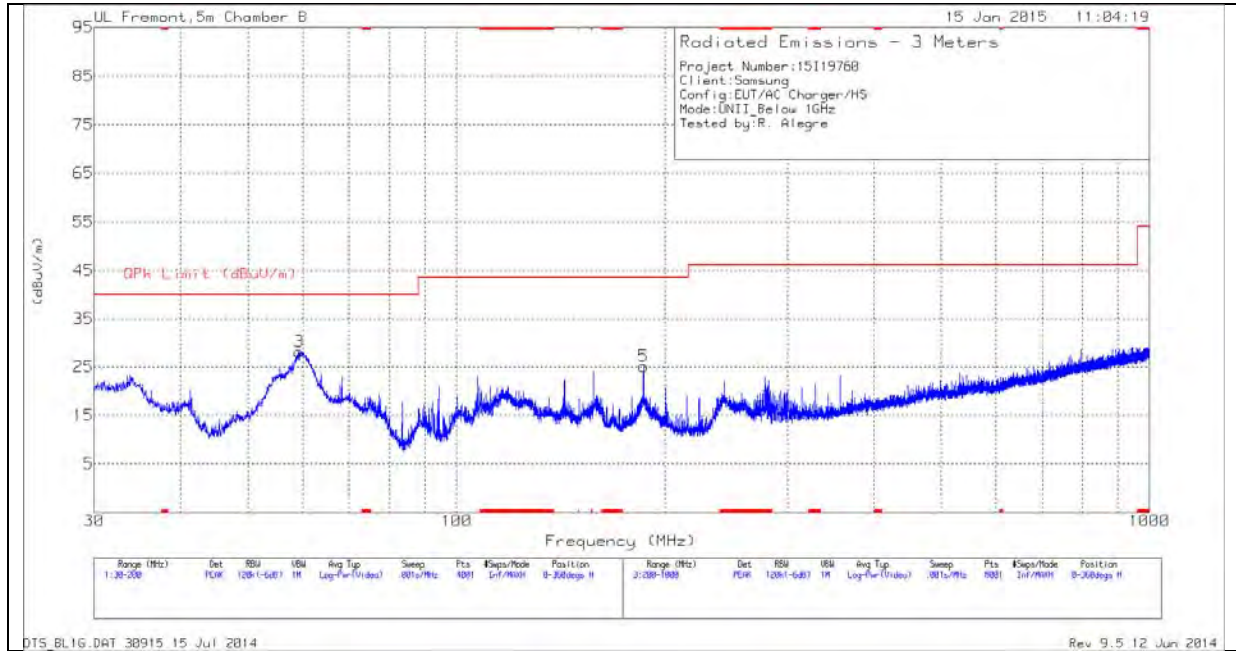

SPURIOUS EMISSIONS 30 TO 1000 MHz (WORST-CASE CONFIGURATION, VERTICAL)

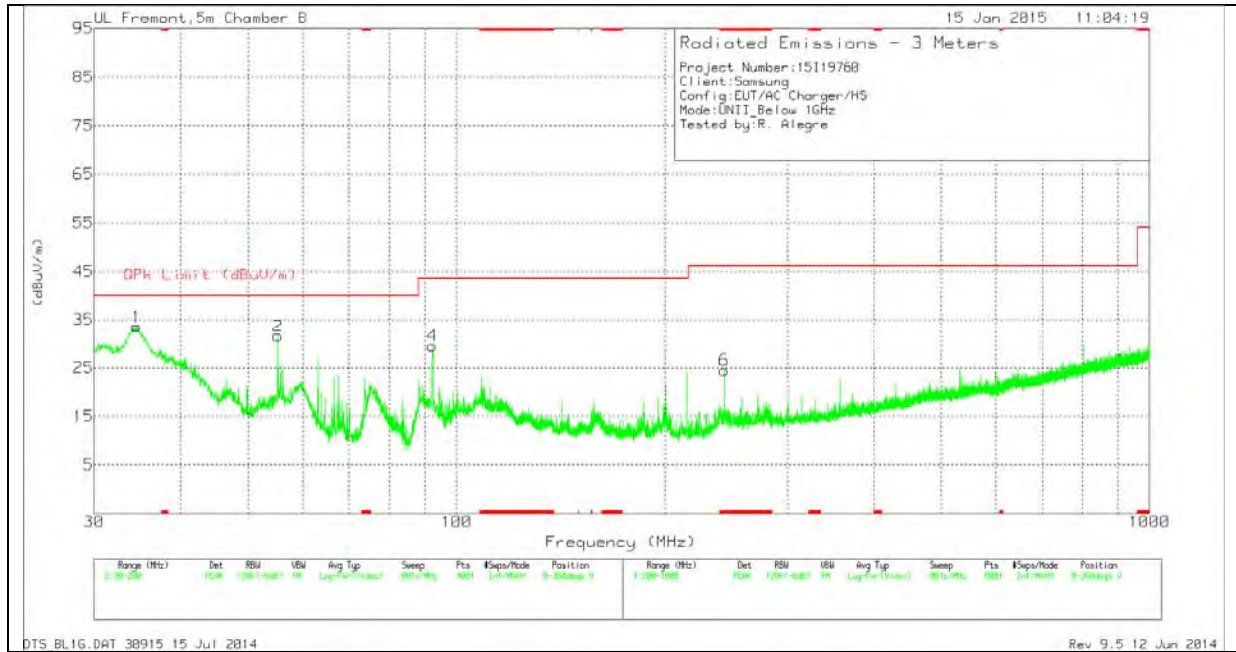

Below 1G Data

Marker	Frequency (MHz)	Meter Reading (dBuV)	Det	AF T243 (dB/m)	Amp/Cbl (dB)	Corrected Reading (dBuV/m)	QPk Limit (dBuV/m)	Margin (dB)	Azimuth (Degs)	Height (cm)	Polarity
6	* 243.4	39.27	PK	11.6	-26.4	24.47	46.02	-21.55	0-360	101	V
1	34.505	44.49	PK	17.8	-28.7	33.59	40	-6.41	0-360	101	V
2	55.2025	52.79	PK	7.3	-28.5	31.59	40	-8.41	0-360	101	V
3	59.24	48.99	PK	7.5	-28.4	28.09	40	-11.91	0-360	400	H
4	92.305	49.4	PK	8.2	-28.1	29.5	43.52	-14.02	0-360	101	V
5	186.145	40.8	PK	11.3	-27	25.1	43.52	-18.42	0-360	100	H

13. AC POWER LINE CONDUCTED EMISSIONS

LIMITS

FCC §15.207 (a)

Frequency of Emission (MHz)	Conducted Limit (dBuV)	
	Quasi-peak	Average
0.15-0.5	66 to 56	56 to 46
0.5-5	56	46
5-30	60	50

*Decreases with the logarithm of the frequency.

TEST PROCEDURE

The EUT is placed on a non-conducting table 40 cm from the vertical ground plane and 80 cm above the horizontal ground plane. The EUT is configured in accordance with ANSI C63.4.

The receiver is set to a resolution bandwidth of 9 kHz. Peak detection is used unless otherwise noted as quasi-peak or average.

Line conducted data is recorded for both NEUTRAL and HOT lines.

RESULTS

6 WORST EMISSIONS

LINE 1 PLOT

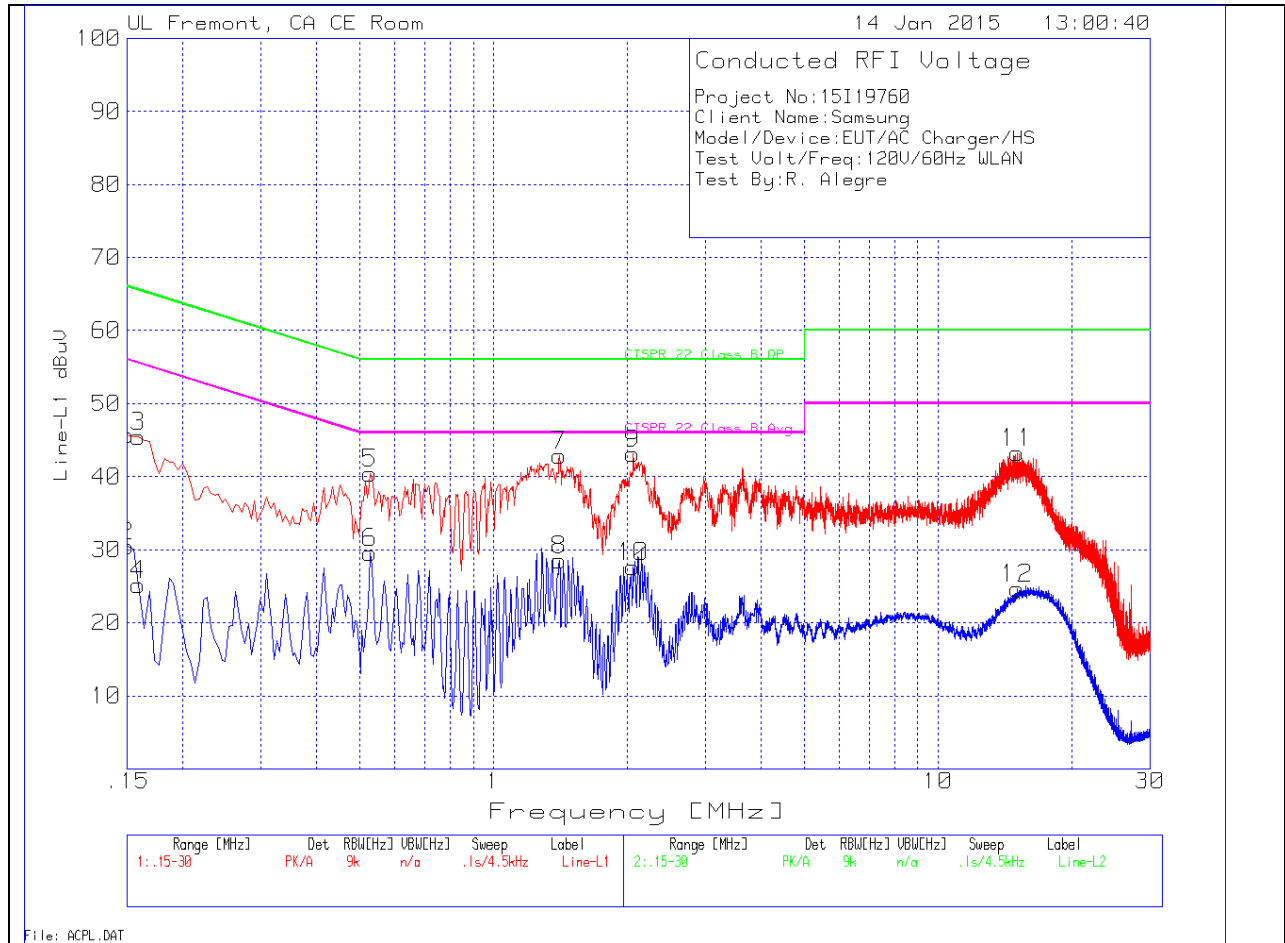

LINE 1 RESULTS

Trace Markers

Marker	Frequency (MHz)	Meter Reading (dBuV)	Det	T24 IL L1 (dB)	LC Cables 1&3 (dB)	Corrected Reading dBuV	CISPR 22 Class B QP	Margin to Limit (dB)	CISPR 22 Class B Avg	Margin to Limit (dB)
1	.15	44.28	PK	1.4	0	45.68	66	-20.32	-	-
2	.15	29.03	Av	1.4	0	30.43	-	-	56	-25.57
3	.159	44.22	PK	1.3	0	45.52	65.5	-19.98	-	-
4	.159	23.88	Av	1.3	0	25.18	-	-	55.5	-30.32
5	.528	40.11	PK	.3	0	40.41	56	-15.59	-	-
6	.528	29.23	Av	.3	0	29.53	-	-	46	-16.47
7	1.4055	42.72	PK	.2	0	42.92	56	-13.08	-	-
8	1.4055	28.39	Av	.2	0	28.59	-	-	46	-17.41
9	2.0625	42.79	PK	.2	.1	43.09	56	-12.91	-	-
10	2.0625	27.31	Av	.2	.1	27.61	-	-	46	-18.39
11	15.0675	42.77	PK	.3	.2	43.27	60	-16.73	-	-
12	15.0675	24.15	Av	.3	.2	24.65	-	-	50	-25.35

LINE 2 PLOT

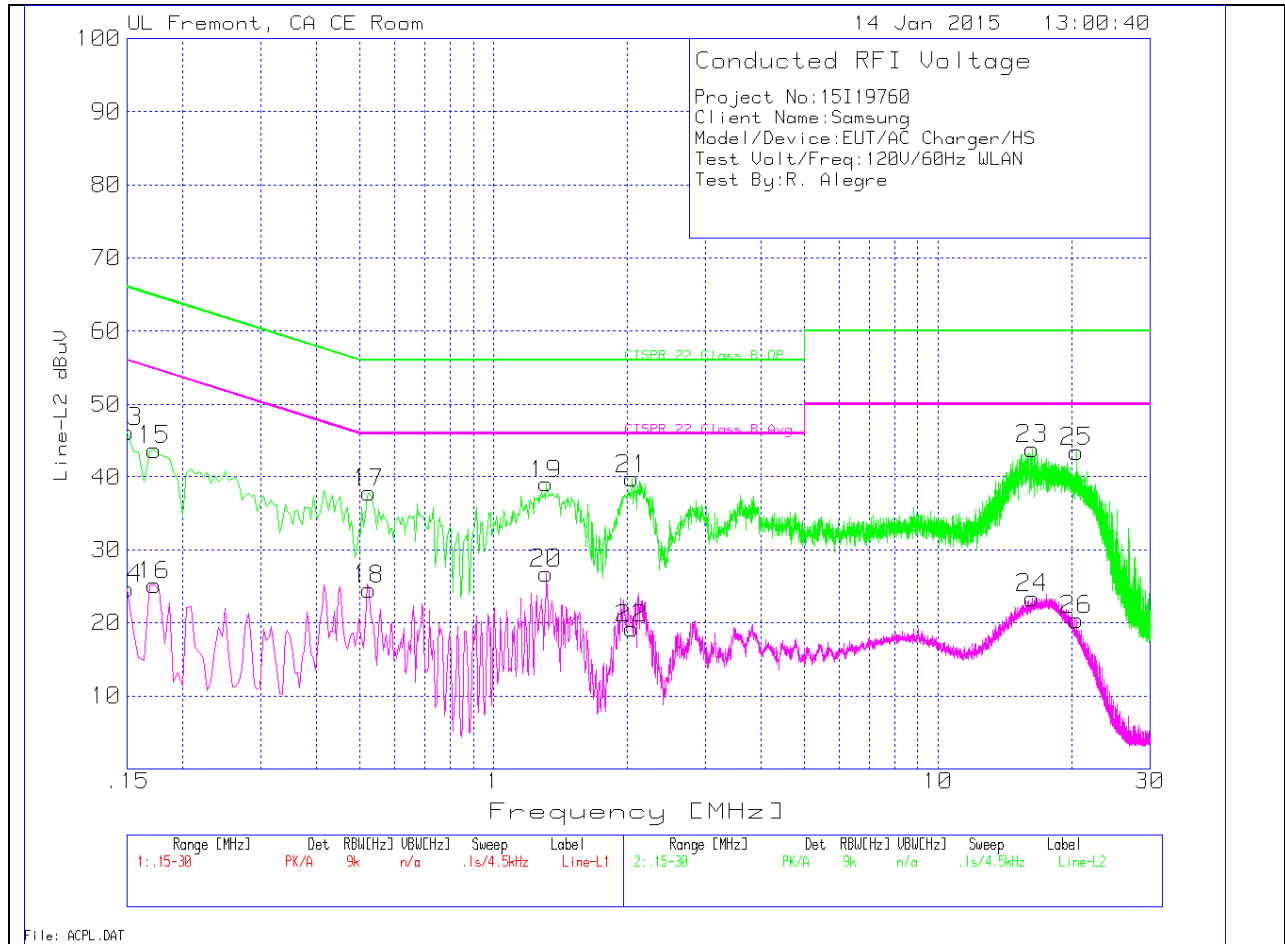

LINE 2 RESULTS

Trace Markers

Marker	Frequency (MHz)	Meter Reading (dBuV)	Det	T24 IL L2 (dB)	LC Cables 2&3 (dB)	Corrected Reading dBuV	CISPR 22 Class B QP	Margin to Limit (dB)	CISPR 22 Class B Avg	Margin to Limit (dB)
13	.15	44.71	PK	1.5	0	46.21	66	-19.79	-	-
14	.15	23.18	Av	1.5	0	24.68	-	-	56	-31.32
15	.1725	42.6	PK	1.2	0	43.8	64.8	-21	-	-
16	.1725	23.93	Av	1.2	0	25.13	-	-	54.8	-29.67
17	.5235	37.4	PK	.4	0	37.8	56	-18.2	-	-
18	.5235	24.18	Av	.4	0	24.58	-	-	46	-21.42
19	1.3155	38.77	PK	.2	.1	39.07	56	-16.93	-	-
20	1.3155	26.43	Av	.2	.1	26.73	-	-	46	-19.27
21	2.049	39.51	PK	.2	.1	39.81	56	-16.19	-	-
22	2.049	18.89	Av	.2	.1	19.19	-	-	46	-26.81
23	16.305	43.39	PK	.3	.2	43.89	60	-16.11	-	-
24	16.305	22.89	Av	.3	.2	23.39	-	-	50	-26.61
25	20.535	43.08	PK	.3	.2	43.58	60	-16.42	-	-
26	20.535	19.9	Av	.3	.2	20.4	-	-	50	-29.6

14. DYNAMIC FREQUENCY SELECTION

14.1. OVERVIEW

14.1.1. LIMITS

INDUSTRY CANADA

IC RSS-210 is closely harmonized with FCC Part 15 DFS rules. The deviations are as follows:

RSS-210 Issue 8 A9.3

Note: For the band 5600–5650 MHz, no operation is permitted.

Until further notice, devices subject to this annex shall not be capable of transmitting in the band 5600–5650 MHz. This restriction is for the protection of Environment Canada weather radars operating in this band.

FCC

§15.407 (h), FCC KDB 905462 D02 “COMPLIANCE MEASUREMENT PROCEDURES FOR UNLICENSED-NATIONAL INFORMATION INFRASTRUCTURE DEVICES OPERATING IN THE 5250-5350 MHz AND 5470-5725 MHz BANDS INCORPORATING DYNAMIC FREQUENCY SELECTION” and KDB 905462 D03 “U-NII CLIENT DEVICES WITHOUT RADAR DETECTION CAPABILITY”.

Table 1: Applicability of DFS requirements prior to use of a channel

Requirement	Operational Mode		
	Master	Client (without radar detection)	Client (with radar detection)
Non-Occupancy Period	Yes	Not required	Yes
DFS Detection Threshold	Yes	Not required	Yes
Channel Availability Check Time	Yes	Not required	Not required
U-NII Detection Bandwidth	Yes	Not required	Yes

Table 2: Applicability of DFS requirements during normal operation

Requirement	Operational Mode		
	Master	Client (without DFS)	Client (with DFS)
DFS Detection Threshold	Yes	Not required	Yes
Channel Closing Transmission Time	Yes	Yes	Yes
Channel Move Time	Yes	Yes	Yes
U-NII Detection Bandwidth	Yes	Not required	Yes

Additional requirements for devices with multiple bandwidth modes	Master Device or Client with Radar DFS	Client (without DFS)
---	--	-------------------------

<i>U-NII Detection Bandwidth and Statistical Performance Check</i>	All BW modes must be tested	Not required
<i>Channel Move Time and Channel Closing Transmission Time</i>	Test using widest BW mode available	Test using the widest BW mode available for the link
<i>All other tests</i>	Any single BW mode	Not required
Note: Frequencies selected for statistical performance check (Section 7.8.4) should include several frequencies within the radar detection bandwidth and frequencies near the edge of the radar detection bandwidth. For 802.11 devices it is suggested to select frequencies in all 20 MHz channel blocks and a null frequency between the bonded 20 MHz channel blocks.		

Table 3: Interference Threshold values, Master or Client incorporating In-Service Monitoring

Maximum Transmit Power	Value
	(see notes)
E.I.R.P. \geq 200 mill watt	-64 dBm
E.I.R.P. < 200 mill watt and power spectral density < 10 dBm/MHz	-62 dBm
E.I.R.P. < 200 mill watt that do not meet power spectral density requirement	-64 dBm
<p>Note 1: This is the level at the input of the receiver assuming a 0 dBi receive antenna</p> <p>Note 2: Throughout these test procedures an additional 1 dB has been added to the amplitude of the test transmission waveforms to account for variations in measurement equipment. This will ensure that the test signal is at or above the detection threshold level to trigger a DFS response.</p> <p>Note 3: E.I.R.P. is based on the highest antenna gain. For MIMO devices refer to KDB publication 662911 D01.</p>	

Table 4: DFS Response requirement values

Parameter	Value
<i>Non-occupancy period</i>	30 minutes
<i>Channel Availability Check Time</i>	60 seconds
<i>Channel Move Time</i>	10 seconds (See Note 1)
<i>Channel Closing Transmission Time</i>	200 milliseconds + approx. 60 milliseconds over remaining 10 second period. (See Notes 1 and 2)

<i>U-NII Detection Bandwidth</i>	Minimum 100% of the U-NII 99% transmission power bandwidth. (See Note 3)
<p>Note 1: <i>Channel Move Time</i> and the <i>Channel Closing Transmission Time</i> should be performed with Radar Type 0. The measurement timing begins at the end of the Radar Type 0 burst.</p> <p>Note 2: The <i>Channel Closing Transmission Time</i> is comprised of 200 milliseconds starting at the beginning of the <i>Channel Move Time</i> plus any additional intermittent control signals required to facilitate a <i>Channel</i> move (an aggregate of 60 milliseconds) during the remainder of the 10 second period. The aggregate duration of control signals will not count quiet periods in between transmissions.</p> <p>Note 3: During the <i>U-NII Detection Bandwidth</i> detection test, radar type 0 should be used. For each frequency step the minimum percentage of detection is 90 percent. Measurements are performed with no data traffic.</p>	

Table 5 – Short Pulse Radar Test Waveforms

Radar Type	Pulse Width (usec)	PRI (usec)	Pulses	Minimum Percentage of Successful Detection	Minimum Trials
0	1	1428	18	See Note 1	See Note 1
1	1	Test A: 15 unique PRI values randomly selected from the list of 23 PRI values in table 5a	Roundup: $\{(1/360) \times (19 \times 10^6 \text{ PRI}_{\text{usec}})\}$	60%	30
		Test B: 15 unique PRI values randomly selected within the range of 518-3066 usec. With a minimum increment of 1 usec, excluding PRI values selected in Test A			
2	1-5	150-230	23-29	60%	30
3	6-10	200-500	16-18	60%	30
4	11-20	200-500	12-16	60%	30
Aggregate (Radar Types 1-4)				80%	120
<p>Note 1: Short Pulse Radar Type 0 should be used for the <i>Detection Bandwidth</i> test, <i>Channel Move Time</i>, and <i>Channel Closing Time</i> tests.</p>					

Table 6 – Long Pulse Radar Test Signal

Radar Waveform Type	Pulse Width (μsec)	Chirp Width (MHz)	PRI (μsec)	Pulses per Burst	Number of Bursts	Minimum Percentage of Successful Detection	Minimum Trials
5	50-100	5-20	1000-2000	1-3	8-20	80%	30

Table 7 – Frequency Hopping Radar Test Signal

Radar Waveform Type	Pulse Width (μsec)	PRI (μsec)	Pulses per Hop	Hopping Rate (kHz)	Hopping Sequence Length (msec)	Minimum Percentage of Successful Detection	Minimum Trials
6	1	333	9	0.333	300	70%	30

14.1.2. TEST AND MEASUREMENT SYSTEM

RADIATED METHOD SYSTEM BLOCK DIAGRAM

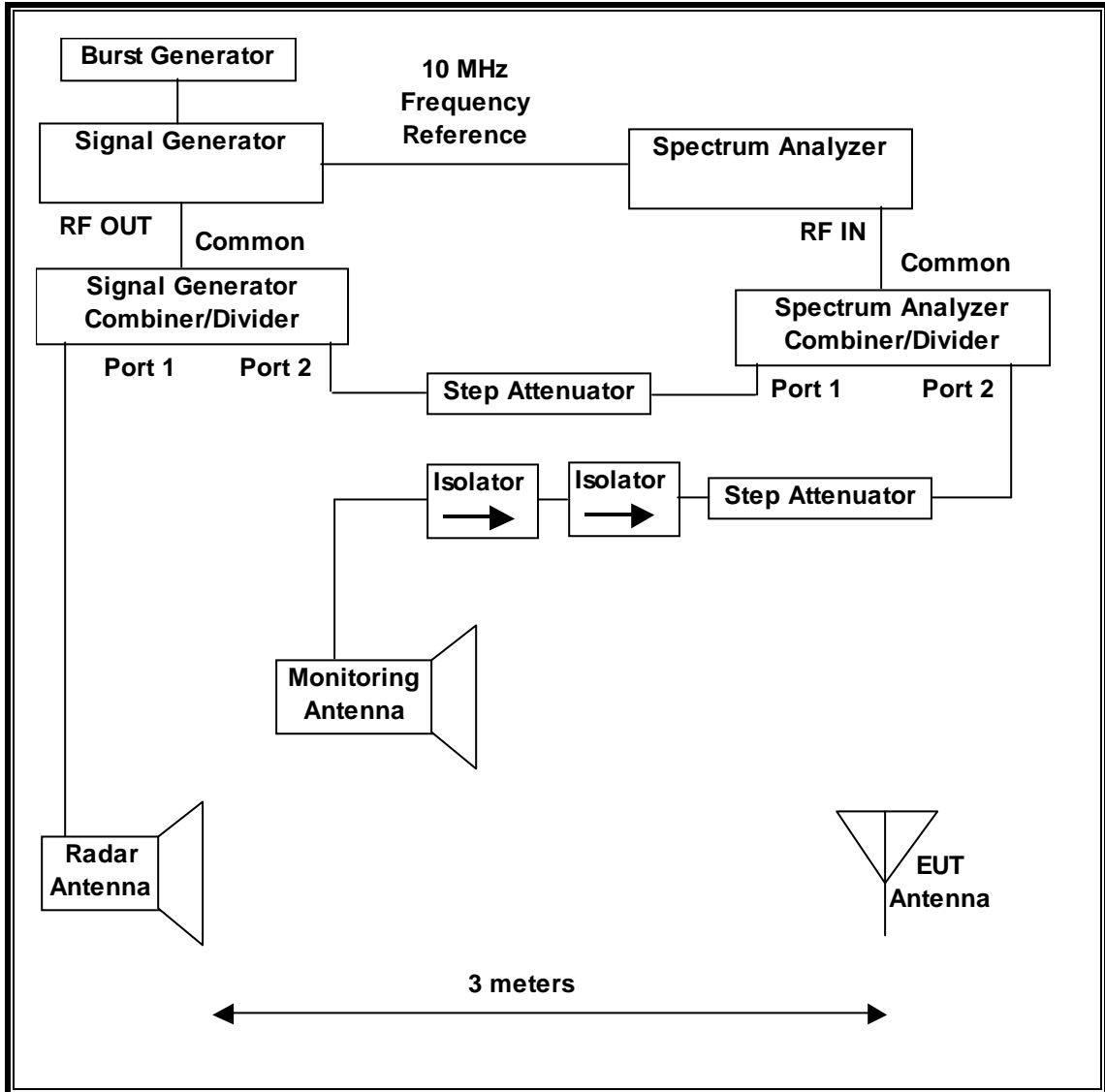

SYSTEM OVERVIEW

The short pulse and long pulse signal generating system utilizes the NTIA software. The Vector Signal Generator has been validated by the NTIA. The hopping signal generating system utilizes the CCS simulated hopping method and system, which has been validated by the DoD, FCC and NTIA. The software selects waveform parameters from within the bounds of the signal type on a random basis using uniform distribution.

The short pulse types 1, 2, 3 and 4, and the long pulse type 5 parameters are randomized at run-time.

The hopping type 6 pulse parameters are fixed while the hopping sequence is based on the August 2005 NTIA Hopping Frequency List. The initial starting point randomized at run-time and each subsequent starting point is incremented by 475. Each frequency in the 100-length segment is compared to the boundaries of the EUT Detection Bandwidth and the software creates a hopping burst pattern in accordance with Section 7.4.1.3 Method #2 Simulated Frequency Hopping Radar Waveform Generating Subsystem of KDB 905462 D02. The frequency of the signal generator is incremented in 1 MHz steps from F_L to F_H for each successive trial. This incremental sequence is repeated as required to generate a minimum of 30 total trials and to maintain a uniform frequency distribution over the entire Detection Bandwidth.

The signal monitoring equipment consists of a spectrum analyzer. The aggregate ON time is calculated by multiplying the number of bins above a threshold during a particular observation period by the dwell time per bin, with the analyzer set to peak detection and max hold.

SYSTEM CALIBRATION

A 50-ohm load is connected in place of the spectrum analyzer, and the spectrum analyzer is connected to a horn antenna via a coaxial cable, with the reference level offset set to (horn antenna gain – coaxial cable loss). The signal generator is set to CW mode. The amplitude of the signal generator is adjusted to yield a level of –64 dBm as measured on the spectrum analyzer.

Without changing any of the instrument settings, the spectrum analyzer is reconnected to the Common port of the Spectrum Analyzer Combiner/Divider. The Reference Level Offset of the spectrum analyzer is adjusted so that the displayed amplitude of the signal is -64 dBm.

The spectrum analyzer displays the level of the signal generator as received at the antenna ports of the Master Device. The interference detection threshold may be varied from the calibrated value of -64 dBm and the spectrum analyzer will still indicate the level as received by the Master Device.

ADJUSTMENT OF DISPLAYED TRAFFIC LEVEL

A link is established between the Master and Slave and the distance between the units is adjusted as needed to provide a suitable received level at the Master and Slave devices. The video test file is streamed to generate WLAN traffic. The monitoring antenna is adjusted so that the WLAN traffic level, as displayed on the spectrum analyzer, is at lower amplitude than the radar detection threshold.

TEST AND MEASUREMENT EQUIPMENT

The following test and measurement equipment was utilized for the DFS tests documented in this report:

TEST EQUIPMENT LIST				
Description	Manufacturer	Model	Asset Number	Cal Due
Spectrum Analyzer, 26.5 GHz	Agilent / HP	E4440A	C01178	09/05/15
Vector Signal Generator, 20GHz	Agilent / HP	E8267C	C01066	09/03/15
Arbitrary Waveform Generator	Agilent / HP	33220A	C01146	04/03/15

14.1.3. SETUP OF EUT

RADIATED METHOD EUT TEST SETUP

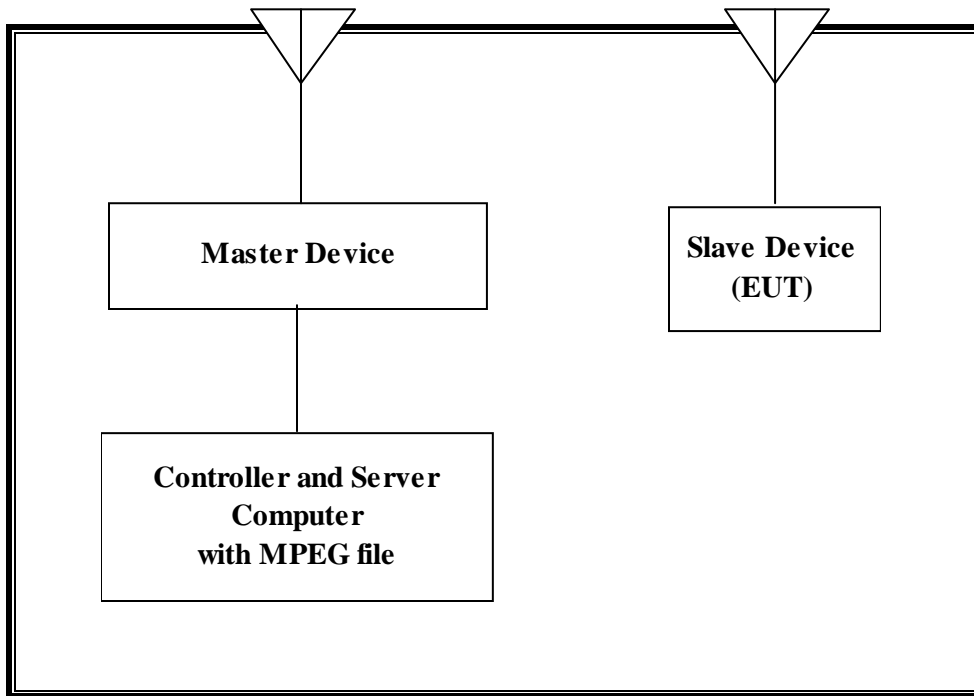

SUPPORT EQUIPMENT

The following support equipment was utilized for the DFS tests documented in this report:

PERIPHERAL SUPPORT EQUIPMENT LIST				
Description	Manufacturer	Model	Serial Number	FCC ID
802.11ac Access Point (Master Device 1)	Cisco	AIR-CAP3702E-A-K9	FTX181570A6	LDK102087
P.O.E. Injector (Master 1)	Phihong	POE30U-560(G)	PHI170102N2	DoC
Notebook PC (Controller/Server)	Dell	PP18L	10657517725	DoC
AC Adapter (Controller/Server PC)	Dell	LA65SN0-00	CN-ODF263-71615-6AU-1019	DoC

14.1.4. DESCRIPTION OF EUT

For FCC the EUT operates over the 5250-5350 MHz and 5470-5725 MHz ranges.

For IC the EUT operates over the 5250-5350 MHz and 5470-5725 MHz ranges, excluding the 5600-5650 MHz range.

The EUT is a Slave Device without Radar Detection.

The highest power level within these bands is 10.5 dBm EIRP in the 5250-5350 MHz band and 10.3 dBm EIRP in the 5470-5725 MHz band.

The only antenna assembly utilized with the EUT has a gain of -0.5 dBi.

The rated output power of the Master unit is > 23dBm (EIRP). Therefore the required interference threshold level is -64 dBm. After correction for procedural adjustments, the required radiated threshold at the antenna port is $-64 + 1 = -63$ dBm.

The calibrated radiated DFS Detection Threshold level is set to -64 dBm. The tested level is lower than the required level hence it provides a margin to the limit.

The EUT uses one transmitter/receiver chain, connected to an antenna to perform radiated tests.

WLAN traffic is generated by streaming the video file TestFile.mp2 "6 ½ Magic Hours" from the Master to the Slave in full motion video mode using the media player with the V2.61 Codec package.

TPC is not required since the maximum EIRP is less than 500 mW (27 dBm).

The EUT utilizes the 802.11a/n architecture. Two nominal channel bandwidths are implemented: 20 MHz and 40 MHz.

UNIFORM CHANNEL SPREADING

This function is not required per KDB 905462.

OVERVIEW OF MASTER DEVICE WITH RESPECT TO §15.407 (h) REQUIREMENTS

The Master Device is a Cisco Access Point, FCC ID: LDK102087. The minimum antenna gain for the Master Device is 3.5 dBi.

The rated output power of the Master unit is $> 23\text{dBm}$ (EIRP). Therefore the required interference threshold level is -64 dBm . After correction for procedural adjustments, the required radiated threshold at the antenna port is $-64 + 1 = -63\text{ dBm}$.

The calibrated radiated DFS Detection Threshold level is set to -64 dBm . The tested level is lower than the required level hence it provides a margin to the limit.

14.2. RESULTS FOR 20 MHz BANDWIDTH

14.2.1. TEST CHANNEL

All tests were performed at a channel center frequency of 5500 MHz.

14.2.2. RADAR WAVEFORM AND TRAFFIC

RADAR WAVEFORM

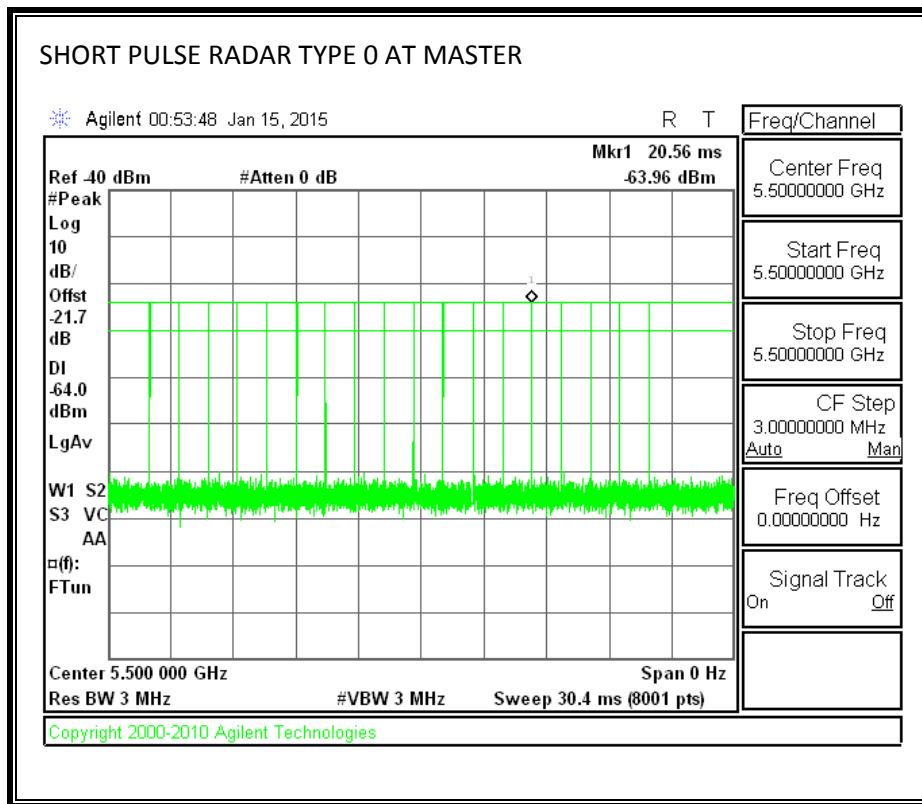

TRAFFIC

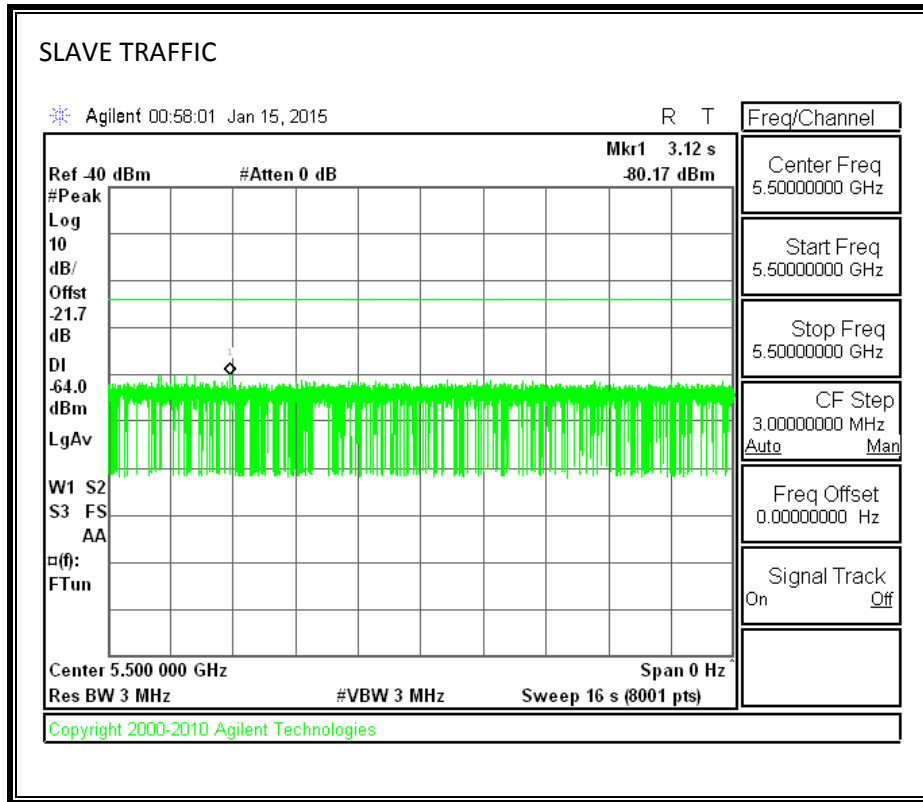

14.2.3. OVERLAPPING CHANNEL TESTS

RESULTS

These tests are not applicable.

14.2.4. MOVE AND CLOSING TIME

REPORTING NOTES

The reference marker is set at the end of last radar pulse.

The delta marker is set at the end of the last WLAN transmission following the radar pulse. This delta is the channel move time.

The aggregate channel closing transmission time is calculated as follows:

Aggregate Transmission Time =

(Number of analyzer bins showing transmission) * (dwell time per bin)

The observation period over which the aggregate time is calculated begins at (Reference Marker + 200 msec) and ends no earlier than (Reference Marker + 10 sec).

RESULTS

Channel Move Time (sec)	Limit (sec)
0.606	10

Aggregate Channel Closing Transmission Time (msec)	Limit (msec)
10.0	60

MOVE TIME

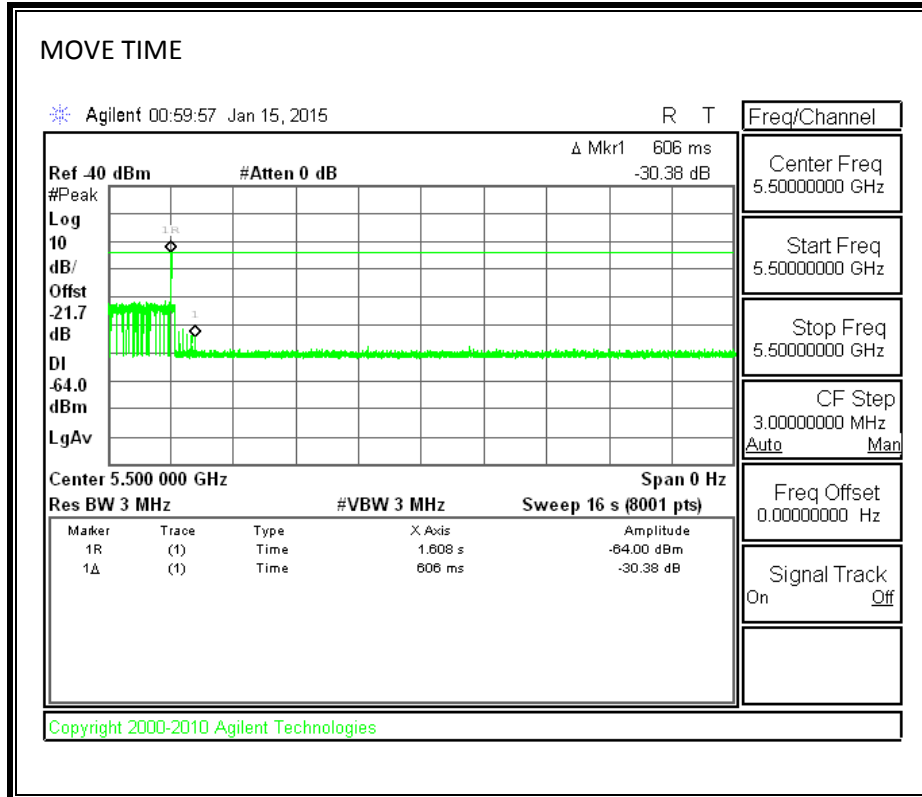

CHANNEL CLOSING TIME

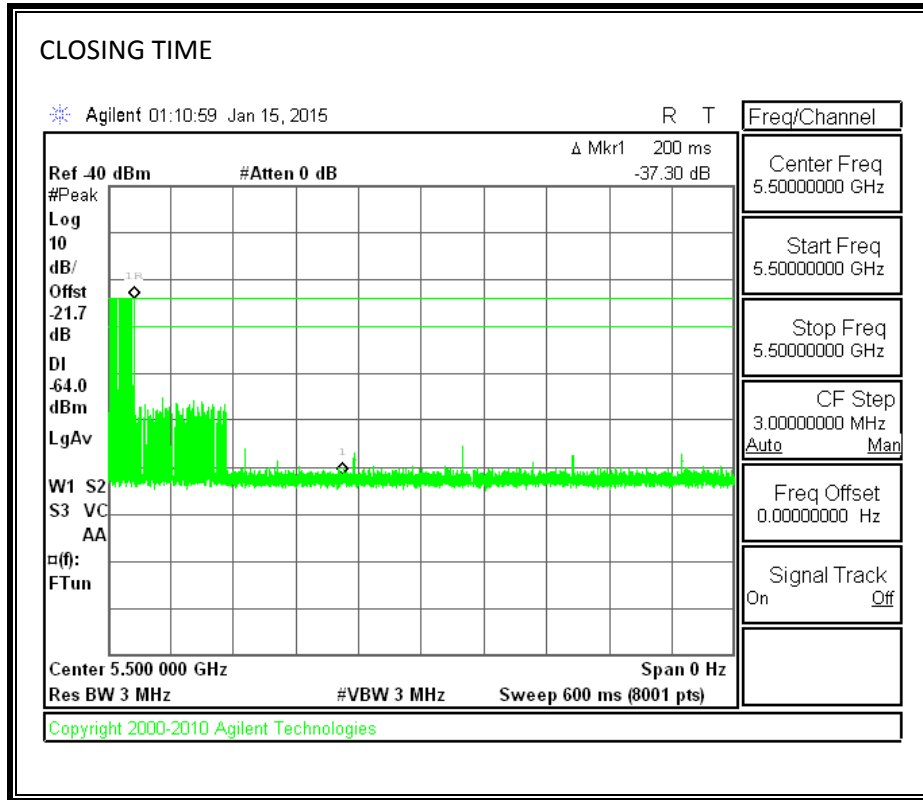

AGGREGATE CHANNEL CLOSING TRANSMISSION TIME

Only intermittent transmissions are observed during the aggregate monitoring period.

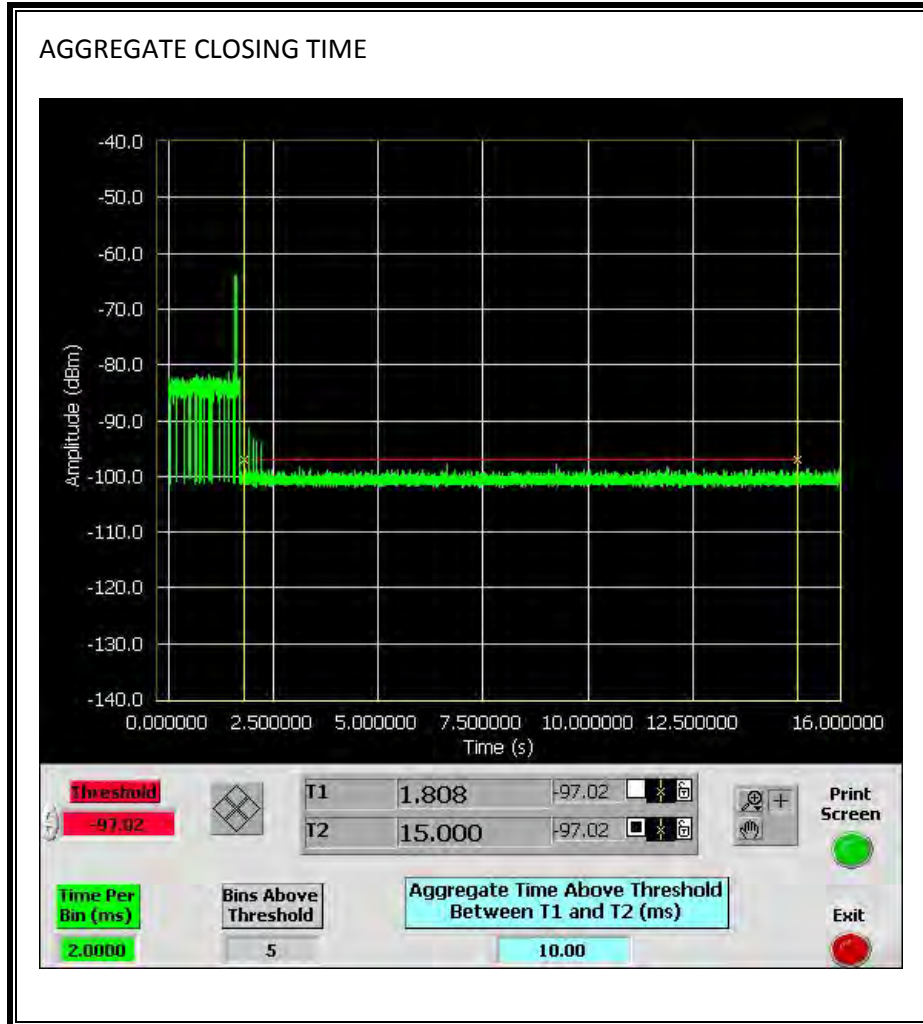

14.3. RESULTS FOR 40 MHz BANDWIDTH

14.3.1. TEST CHANNEL

All tests were performed at a channel center frequency of 5510 MHz.

14.3.2. RADAR WAVEFORM AND TRAFFIC

RADAR WAVEFORM

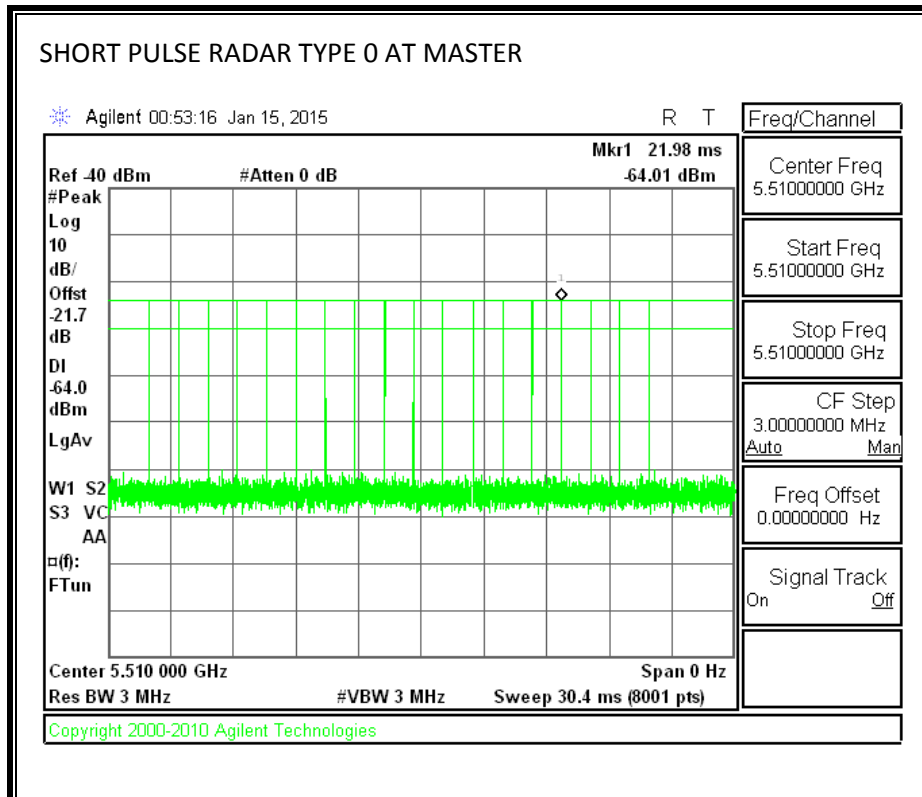

TRAFFIC

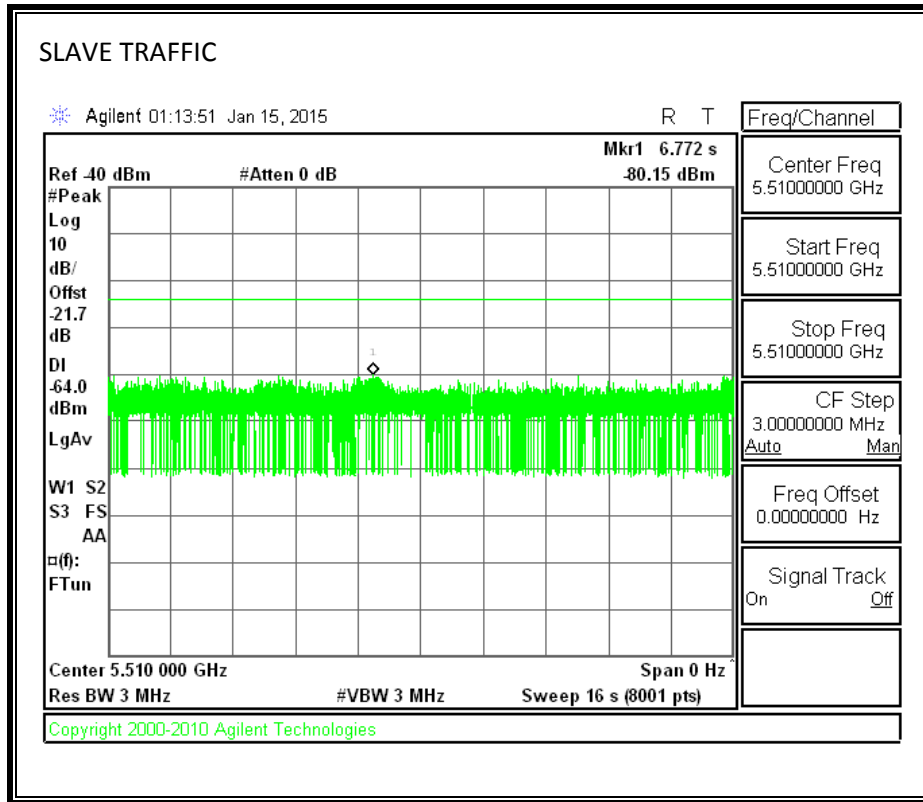

14.3.3. OVERLAPPING CHANNEL TESTS

RESULTS

These tests are not applicable.

14.3.4. MOVE AND CLOSING TIME

REPORTING NOTES

The reference marker is set at the end of last radar pulse.

The delta marker is set at the end of the last WLAN transmission following the radar pulse. This delta is the channel move time.

The aggregate channel closing transmission time is calculated as follows:

Aggregate Transmission Time =

(Number of analyzer bins showing transmission) * (dwell time per bin)

The observation period over which the aggregate time is calculated begins at (Reference Marker + 200 msec) and ends no earlier than (Reference Marker + 10 sec).

RESULTS

Channel Move Time (sec)	Limit (sec)
0.626	10

Aggregate Channel Closing Transmission Time (msec)	Limit (msec)
12.0	60

CHANNEL CLOSING TIME

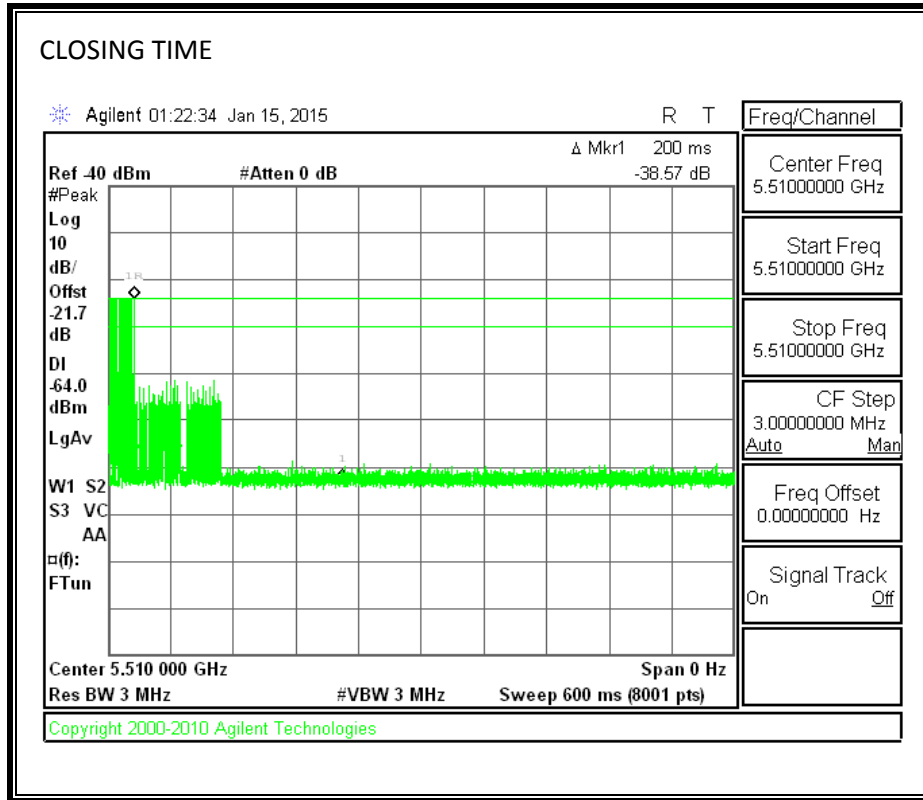

AGGREGATE CHANNEL CLOSING TRANSMISSION TIME

No transmissions are observed during the aggregate monitoring period.

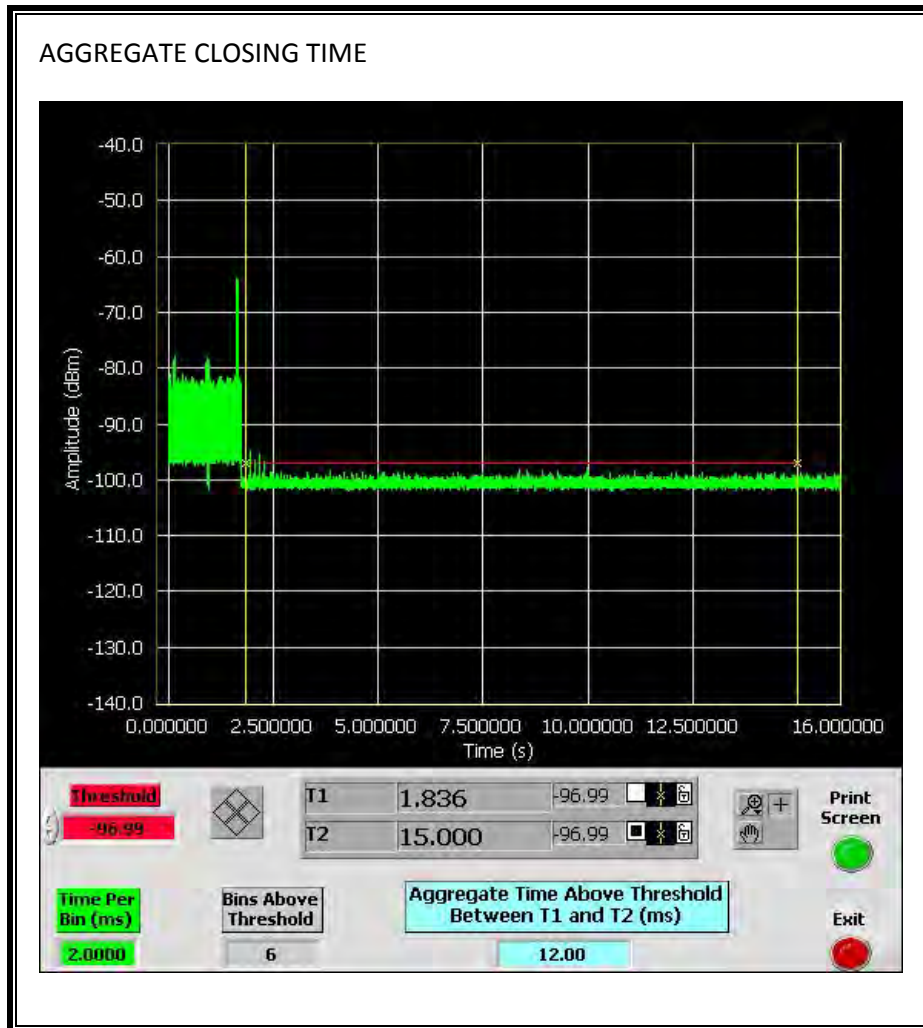

14.3.5. 10-MINUTE BEACON MONITORING PERIOD

RESULTS

No EUT transmissions were observed on the test channel during the 10-minute observation time.

