



## SAR EVALUATION REPORT

**Applicant Name:**  
 Samsung Electronics, Co. Ltd.  
 129, Samsung-ro, Maetan dong,  
 Yeongtong-gu, Suwon-si  
 Gyeonggi-do 443-742, Korea

**Date of Testing:**  
 01/06/2014-01/24/2014  
**Test Site/Location:**  
 PCTEST Lab, Columbia, MD, USA  
**Document Serial No.:**  
 0Y1312302508.A3L

**FCC ID:** A3LSMT331

**APPLICANT:** SAMSUNG ELECTRONICS, CO. LTD.

**DUT Type:** Portable Tablet  
**Application Type:** Certification  
**FCC Rule Part(s):** CFR §2.1093  
**Model(s):** SM-T331

| Equipment Class                                   | Band & Mode        | Tx Frequency          | Measured Conducted Power [dBm] | SAR              |                      |
|---|--------------------|-----------------------|--------------------------------|------------------|----------------------|
|   |                    |                       |                                | 1 gm Head (W/kg) | 1 gm Body SAR (W/kg) |
| PCE   | GSM/GPRS/EDGE 850  | 824.20 - 848.80 MHz   | 29.56                          | 0.98             | 0.98                 |
| PCE   | GSM/GPRS/EDGE 1900 | 1850.20 - 1909.80 MHz | 25.55                          | 0.50             | 0.60                 |
| PCE   | UMTS 850           | 826.40 - 846.60 MHz   | 22.91                          | 1.07             | 0.55                 |
| PCE   | UMTS 1900          | 1852.4 - 1907.6 MHz   | 21.63                          | 0.51             | 0.91                 |
| DTS   | 2.4 GHz WLAN       | 2412 - 2462 MHz       | 15.13                          | < 0.1            | 0.29                 |
| DTS   | Bluetooth LE       | 2402-2480 MHz         | 3.20                           | N/A              |                      |
| DTS   | 5.8 GHz WLAN       | 5745 - 5825 MHz       | 10.33                          | < 0.1            | 0.62                 |
| NII   | 5.2 GHz WLAN       | 5180 - 5240 MHz       | 9.89                           | < 0.1            | 1.07                 |
| NII   | 5.3 GHz WLAN       | 5260 - 5320 MHz       | 10.48                          | < 0.1            | 0.98                 |
| NII   | 5.5 GHz WLAN       | 5500 - 5700 MHz       | 10.12                          | < 0.1            | 1.04                 |
| DSS   | Bluetooth          | 2402 - 2480 MHz       | 10.18                          | N/A              | 0.13                 |
| <b>Simultaneous SAR per KDB 690783 D01v01r02:</b> |                    |                       |                                | 1.11             | 1.55                 |



Note: Powers in the above table represent output powers for the SAR test configurations and may not represent the highest output powers for all configurations for each mode.

This wireless portable device has been shown to be capable of compliance for localized specific absorption rate (SAR) for uncontrolled environment/general population exposure limits specified in ANSI/IEEE C95.1-1992 and has been tested in accordance with the measurement procedures specified in Section 1.7 of this report; for North American frequency bands only.

I attest to the accuracy of data. All measurements reported herein were performed by me or were made under my supervision and are correct to the best of my knowledge and belief. I assume full responsibility for the completeness of these measurements and vouch for the qualifications of all persons taking them. Test results reported herein relate only to the item(s) tested.



  
 Randy Ortanez  
 President



|  |   |                                     |   |  |
|--|---|-------------------------------------|---|--|
| <b>FCC ID:</b> A3LSMT331                 |  | <b>SAR EVALUATION REPORT</b>        |  | <b>Reviewed by:</b><br>Quality Manager |
| <b>Document S/N:</b><br>0Y1312302508.A3L | <b>Test Dates:</b><br>01/06/2014-01/24/2014   | <b>DUT Type:</b><br>Portable Tablet | Page 1 of 47  |  |

# TABLE OF CONTENTS

|   |  |    |
|---|--|----|
| 1   | DEVICE UNDER TEST .....                          | 3  |
| 2   | INTRODUCTION .....                               | 8  |
| 3   | DOSIMETRIC ASSESSMENT .....                      | 9  |
| 4   | DEFINITION OF REFERENCE POINTS .....             | 10 |
| 5   | TEST CONFIGURATION POSITIONS FOR HANDSETS .....  | 11 |
| 6   | RF EXPOSURE LIMITS .....                         | 13 |
| 7   | FCC MEASUREMENT PROCEDURES.....                  | 14 |
| 8   | RF CONDUCTED POWERS.....                         | 17 |
| 9   | SYSTEM VERIFICATION.....                         | 24 |
| 10  | SAR DATA SUMMARY .....                           | 26 |
| 11  | FCC MULTI-TX AND ANTENNA SAR CONSIDERATIONS..... | 32 |
| 12  | SAR MEASUREMENT VARIABILITY .....                | 41 |
| 13  | EQUIPMENT LIST.....                              | 42 |
| 14  | MEASUREMENT UNCERTAINTIES .....                  | 43 |
| 15  | CONCLUSION.....                                  | 45 |
| 16  | REFERENCES .....                                 | 46 |
| APPENDIX A: SAR TEST PLOTS                            |  |    |
| APPENDIX B: SAR DIPOLE VERIFICATION PLOTS             |  |    |
| APPENDIX C: PROBE AND DIPOLE CALIBRATION CERTIFICATES |  |    |
| APPENDIX D: SAR TISSUE SPECIFICATIONS                 |  |    |
| APPENDIX E: SAR SYSTEM VALIDATION                     |  |    |
| APPENDIX F: SAR TEST SETUP PHOTOGRAPHS                |  |    |
| APPENDIX G: SAR SENSOR TRIGGERING DATA SUMMARY        |  |    |

|  |   |                                     |   |  |
|--|---|-------------------------------------|---|--|
| <b>FCC ID:</b> A3LSMT331                 |  | <b>SAR EVALUATION REPORT</b>        |  | <b>Reviewed by:</b><br>Quality Manager |
| <b>Document S/N:</b><br>0Y1312302508.A3L | <b>Test Dates:</b><br>01/06/2014-01/24/2014   | <b>DUT Type:</b><br>Portable Tablet |   | Page 2 of 47                           |

# 1 DEVICE UNDER TEST

## 1.1 Device Overview

| Band & Mode        | Operating Modes | Tx Frequency          |
|--------------------|-----------------|-----------------------|
| GSM/GPRS/EDGE 850  | Voice/Data      | 824.20 - 848.80 MHz   |
| GSM/GPRS/EDGE 1900 | Voice/Data      | 1850.20 - 1909.80 MHz |
| UMTS 850           | Voice/Data      | 826.40 - 846.60 MHz   |
| UMTS 1900          | Voice/Data      | 1852.4 - 1907.6 MHz   |
| 2.4 GHz WLAN       | Data            | 2412 - 2462 MHz       |
| Bluetooth LE       | Data            | 2402-2480 MHz         |
| 5.8 GHz WLAN       | Data            | 5745 - 5825 MHz       |
| 5.2 GHz WLAN       | Data            | 5180 - 5240 MHz       |
| 5.3 GHz WLAN       | Data            | 5260 - 5320 MHz       |
| 5.5 GHz WLAN       | Data            | 5500 - 5700 MHz       |
| Bluetooth          | Data            | 2402 - 2480 MHz       |
| ANT+               | Data            | 2402 - 2480 MHz       |

## 1.2 Power Reduction for SAR

This device uses one proximity sensor for SAR compliance. The capacitive proximity sensor is activated when the device is held to ear and used in close proximity to the user's body. The proximity sensor triggers power reduction for all voice and data modes. There are no body-worn accessories for this device.



The held-to-ear RF exposure conditions were evaluated at reduced power according to the Head SAR test positions described in IEEE 1528. Since the device is a full size tablet, the Body SAR was evaluated per FCC KDB Publication 616217 D04 for full sized tablets.

## 1.3 Nominal and Maximum Output Power Specifications

This device operates using the following maximum and nominal output power specifications. SAR values were scaled to the maximum allowed power to determine compliance per KDB Publication 447498 D01v05.

### 1.3.1 Maximum Power – Capacitive Sensor Not Active:

| Mode / Band        |         | Voice (dBm) | Burst Average GMSK (dBm) |       |       |       | Burst Average 8-PSK (dBm) |       |       |       |
|--------------------|---------|-------------|--------------------------|-------|-------|-------|---------------------------|-------|-------|-------|
|                    |         |             | 1 TX                     | 2 TX  | 3 TX  | 4 TX  | 1 TX                      | 2 TX  | 3 TX  | 4 TX  |
|                    |         |             | Slot                     | Slots | Slots | Slots | Slots                     | Slots | Slots | Slots |
| GSM/GPRS/EDGE 850  | Maximum | 33.5        | 33.5                     | 30.5  | 29.0  | 27.0  | 27.0                      | 26.5  | 26.5  | 23.0  |
|                    | Nominal | 33.0        | 33.0                     | 30.0  | 28.5  | 26.5  | 26.5                      | 26.0  | 26.0  | 22.5  |
| GSM/GPRS/EDGE 1900 | Maximum | 30.5        | 30.5                     | 28.5  | 26.5  | 25.0  | 25.5                      | 25.5  | 25.0  | 22.0  |
|                    | Nominal | 30.0        | 30.0                     | 28.0  | 26.0  | 24.5  | 25.0                      | 25.0  | 24.5  | 21.5  |

|                                   |   |                              |   |                                 |
|-----------------------------------|---|------------------------------|---|---------------------------------|
| FCC ID: A3LSMT331                 |  | <b>SAR EVALUATION REPORT</b> |  | Reviewed by:<br>Quality Manager |
| Document S/N:<br>0Y1312302508.A3L | Test Dates:<br>01/06/2014-01/24/2014  | DUT Type:<br>Portable Tablet |   | Page 3 of 47                    |



| Mode / Band            |         | Modulated Average (dBm) |               |               |
|------------------------|---------|-------------------------|---------------|---------------|
|                        |         | 3GPP<br>WCDMA           | 3GPP<br>HSDPA | 3GPP<br>HSUPA |
|                        |         | Rel 99                  | Rel 5         | Rel 6         |
| UMTS Band 5 (850 MHz)  | Maximum | <b>23.5</b>             | <b>22.5</b>   | <b>22.0</b>   |
|                        | Nominal | <b>23.0</b>             | <b>22.0</b>   | <b>21.5</b>   |
| UMTS Band 2 (1900 MHz) | Maximum | <b>22.0</b>             | <b>21.5</b>   | <b>21.0</b>   |
|                        | Nominal | <b>21.5</b>             | <b>21.0</b>   | <b>20.5</b>   |

| Mode / Band                       |         | Modulated Average (dBm) |
|-----------------------------------|---------|-------------------------|
| IEEE 802.11b (2.4 GHz)            | Maximum | <b>15.5</b>             |
|                                   | Nominal | <b>15.0</b>             |
| IEEE 802.11g (2.4 GHz)            | Maximum | <b>13.5</b>             |
|                                   | Nominal | <b>13.0</b>             |
| IEEE 802.11n (2.4 GHz)            | Maximum | <b>11.0</b>             |
|                                   | Nominal | <b>10.5</b>             |
| IEEE 802.11a (5 GHz)              | Maximum | <b>10.5</b>             |
|                                   | Nominal | <b>10.0</b>             |
| IEEE 802.11n<br>(5 GHz 40 MHz BW) | Maximum | <b>7.5</b>              |
|                                   | Nominal | <b>7.0</b>              |
| IEEE 802.11n<br>(5 GHz 20 MHz BW) | Maximum | <b>10.5</b>             |
|                                   | Nominal | <b>10.0</b>             |
| Bluetooth                         | Maximum | <b>10.5</b>             |
|                                   | Nominal | <b>10.0</b>             |
| Bluetooth LE                      | Maximum | <b>3.5</b>              |
|                                   | Nominal | <b>3.0</b>              |

### 1.3.2 Reduced Power – Capacitive Sensor Active:

| Mode / Band        |         | Voice (dBm) | Burst Average GMSK (dBm) |             |             |             | Burst Average 8-PSK (dBm) |             |             |             |
|--------------------|---------|-------------|--------------------------|-------------|-------------|-------------|---------------------------|-------------|-------------|-------------|
|                    |         |             | 1 TX Slot                | 1 TX Slots  | 2 TX Slots  | 3 TX Slots  | 4 TX Slots                | 1 TX Slots  | 2 TX Slots  | 3 TX Slots  |
| GSM/GPRS/EDGE 850  | Maximum | <b>30.5</b> | <b>30.5</b>              | <b>27.0</b> | <b>26.0</b> | <b>24.0</b> | <b>25.5</b>               | <b>25.5</b> | <b>25.5</b> | <b>23.0</b> |
|                    | Nominal | <b>30.0</b> | <b>30.0</b>              | <b>26.5</b> | <b>25.5</b> | <b>23.5</b> | <b>25.0</b>               | <b>25.0</b> | <b>25.0</b> | <b>22.5</b> |
| GSM/GPRS/EDGE 1900 | Maximum | <b>23.5</b> | <b>23.5</b>              | <b>21.0</b> | <b>19.0</b> | <b>18.0</b> | <b>22.5</b>               | <b>20.0</b> | <b>18.5</b> | <b>17.5</b> |
|                    | Nominal | <b>23.0</b> | <b>23.0</b>              | <b>20.5</b> | <b>18.5</b> | <b>17.5</b> | <b>22.0</b>               | <b>19.5</b> | <b>18.0</b> | <b>17.0</b> |

| Mode / Band            |         | Modulated Average (dBm) |               |               |
|------------------------|---------|-------------------------|---------------|---------------|
|                        |         | 3GPP<br>WCDM            | 3GPP<br>HSDPA | 3GPP<br>HSUPA |
|                        |         | Rel 99                  | Rel 5         | Rel 6         |
| UMTS Band 5 (850 MHz)  | Maximum | <b>22.0</b>             | <b>21.0</b>   | <b>20.5</b>   |
|                        | Nominal | <b>21.5</b>             | <b>20.5</b>   | <b>20.0</b>   |
| UMTS Band 2 (1900 MHz) | Maximum | <b>14.5</b>             | <b>13.5</b>   | <b>13.0</b>   |
|                        | Nominal | <b>14.0</b>             | <b>13.0</b>   | <b>12.5</b>   |

|  |   |                                     |   |  |
|--|---|-------------------------------------|---|--|
| FCC ID: A3LSMT331                        |  <b>PCTEST</b><br>ENGINEERING LABORATORY, INC. | <b>SAR EVALUATION REPORT</b>        |  | <b>Reviewed by:</b><br>Quality Manager |
| <b>Document S/N:</b><br>0Y1312302508.A3L | <b>Test Dates:</b><br>01/06/2014-01/24/2014   | <b>DUT Type:</b><br>Portable Tablet |   | Page 4 of 47                           |

## 1.4 DUT Antenna Locations

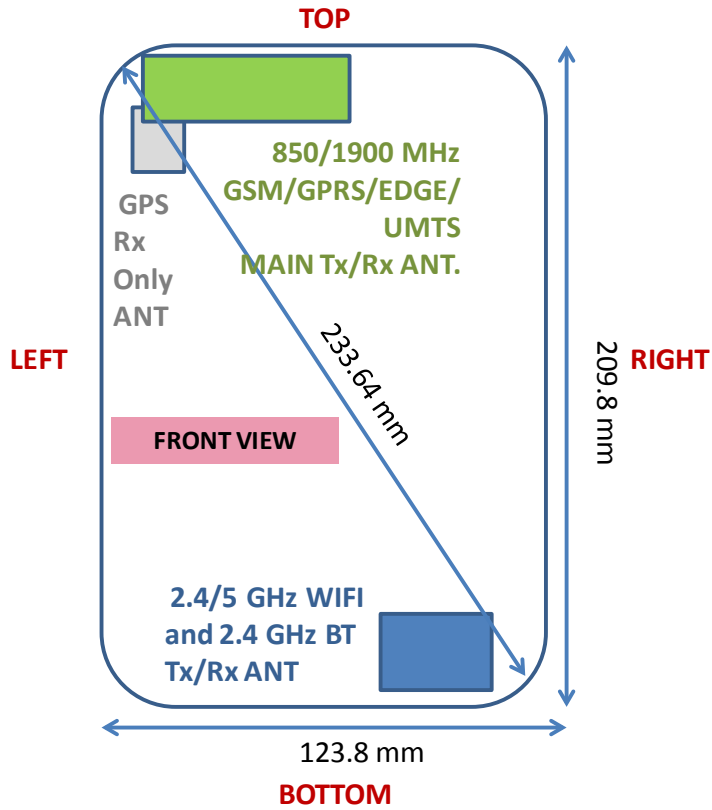



Figure 1-1  
DUT Antenna Locations

Table 1-1  
Body Sides for SAR Testing

| Mode         | Back | Top | Bottom | Right | Left |
|--------------|------|-----|--------|-------|------|
| GPRS 850     | Yes  | Yes | No     | No    | Yes  |
| GPRS 1900    | Yes  | Yes | No     | No    | Yes  |
| UMTS 850     | Yes  | Yes | No     | No    | Yes  |
| UMTS 1900    | Yes  | Yes | No     | No    | Yes  |
| 2.4 GHz WLAN | Yes  | No  | Yes    | Yes   | No   |
| Bluetooth    | Yes  | No  | Yes    | Yes   | No   |
| 5 GHz WLAN   | Yes  | No  | Yes    | Yes   | No   |

Note: Per FCC KDB 616217 D04v01r01, Particular DUT edges were not required to be evaluated for SAR based on the SAR exclusion threshold in KDB 447498 D01v05r01. The antenna document shows the distances between the transmit antennas and the edges of the device.

|                                   |  |                              |   |                                 |
|-----------------------------------|--|------------------------------|---|---------------------------------|
| FCC ID: A3LSMT331                 |  PCTEST<br>ENGINEERING LABORATORY, INC. | SAR EVALUATION REPORT        |  | Reviewed by:<br>Quality Manager |
| Document S/N:<br>0Y1312302508.A3L | Test Dates:<br>01/06/2014-01/24/2014   | DUT Type:<br>Portable Tablet |   | Page 5 of 47                    |

## 1.5 Simultaneous Transmission Capabilities

According to FCC KDB Publication 447498 D05v01, transmitters are considered to be transmitting simultaneously when there is overlapping transmission, with the exception of transmissions during network hand-offs with maximum hand-off duration less than 30 seconds. This device contains multiple transmitters that may operate simultaneously, and therefore requires a simultaneous transmission analysis according to FCC KDB Publication 447498 D01v05 3) procedures.

**Table 1-2  
Simultaneous Transmission Scenarios**

| No. | Capable Transmit Configuration      | Head | Body |
|-----|-------------------------------------|------|------|
| 1   | GSM voice + 2.4 GHz WI-FI           | Yes  | Yes  |
| 2   | GSM voice + 5 GHz WI-FI             | Yes  | Yes  |
| 3   | GSM voice + 2.4 GHz Bluetooth       | N/A  | Yes  |
| 4   | UMTS voice/data + 2.4 GHz WI-FI     | Yes  | Yes  |
| 5   | UMTS voice/data + 5 GHz WI-FI       | Yes  | Yes  |
| 6   | UMTS voice/data + 2.4 GHz Bluetooth | N/A  | Yes  |
| 10  | GPRS/EDGE data + 2.4 GHz WI-FI      | N/A  | Yes  |
| 11  | GPRS/EDGE data + 5 GHz WI-FI        | N/A  | Yes  |
| 12  | GPRS/EDGE data + 2.4 GHz Bluetooth  | N/A  | Yes  |

**Notes:**

- 2.4 GHz WLAN, 2.4 GHz Bluetooth, and 5 GHz WLAN share the same antenna path and cannot transmit simultaneously.
- When the user utilizes multiple services in UMTS 3G mode, it uses multi-Radio Access Bearer or multi-RAB. The power control is based on a physical control channel (Dedicated Physical Control Channel [DOCCH]) and power control will be adjusted to meet the needs of both services. Therefore, the UMTS+WLAN scenario also represents the UMTS Voice/DATA + WLAN Hotspot scenario.
- Per FCC KDB 616217 D04, when voice mode is limited to speaker mode or headset operations for body configurations only, additional SAR testing for tablet voice use is not required. Therefore Voice standalone and simultaneous combinations are not evaluated for body configurations.

## 1.6 SAR Test Exclusions Applied



### (A) WIFI/BT

Per FCC KDB 447498 D01v05, the SAR exclusion threshold for distances <50mm is defined by the following equation:

$$\frac{\text{Max Power of Channel (mW)}}{\text{Test Separation Dist (mm)}} * \sqrt{\text{Frequency(GHz)}} \leq 3.0$$

Based on the maximum conducted power of Bluetooth LE (rounded to the nearest mW) and the antenna to user separation distance, Bluetooth LE SAR was not required;  $[(2/5) * \sqrt{2.44}] = 0.6 < 3.0$ . Per KDB Publication 447498 D01v05, the maximum power of the channel was rounded to the nearest mW before calculation.

This device supports 20 MHz and 40 MHz Bandwidths for IEEE 802.11n for 5 GHz WIFI only. IEEE 802.11n was not evaluated for SAR since the average output power of 20 MHz and 40 MHz bandwidths was not more than 0.25 dB higher than the average output power of IEEE 802.11a.

|                                   |  |                              |   |                                 |
|-----------------------------------|--|------------------------------|---|---------------------------------|
| FCC ID: A3LSMT331                 |  PCTEST<br>ENGINEERING LABORATORY, INC. | SAR EVALUATION REPORT        |  | Reviewed by:<br>Quality Manager |
| Document S/N:<br>0Y1312302508.A3L | Test Dates:<br>01/06/2014-01/24/2014   | DUT Type:<br>Portable Tablet |   | Page 6 of 47                    |

## (B) Licensed Transmitter(s)

GSM/GPRS/EDGE DTM is not supported for US bands. Therefore, the GSM Voice modes in this report do not transmit simultaneously with GPRS/EDGE Data.

This device is only capable of QPSK HSUPA in the uplink. Therefore, no additional SAR tests are required beyond that described for devices with HSUPA in KDB 941225 D01v02.



### 1.7 Guidance Applied

- IEEE 1528-2003
- FCC KDB Publication 941225 D01-D06 (2G/3G)
- FCC KDB Publication 248227 D01v01r02 (SAR Considerations for 802.11 Devices)
- FCC KDB Publication 447498 D01v05 (General SAR Guidance)
- FCC KDB Publication 865664 D01-D02 (SAR Measurements up to 6 GHz)
- FCC KDB Publication 616217 D04 (Tablet SAR Considerations)
- October 2013 TCB Workshop Notes (GPRS SAR consideration)

### 1.8 Device Serial Numbers

Several samples were used with identical hardware to support SAR testing. The manufacturer has confirmed that the device(s) tested have the same physical, mechanical and thermal characteristics and are within operational tolerances expected for production units.

| Mode/Band          | Head Serial Number | Max Power Body Serial Number | Reduced Power Serial Number |
|--------------------|--------------------|------------------------------|-----------------------------|
| GSM/GPRS/EDGE 850  | 30-12-02           | PCT04                        | PCT03                       |
| GSM/GPRS/EDGE 1900 | 30-12-02           | PCT04                        | PCT03                       |
| UMTS 850           | 30-12-02           | 16-01-01                     | 30-12-02                    |
| UMTS 1900          | 30-12-02           | 16-01-01                     | 30-12-02                    |
| Bluetooth          | -                  | 000815/3                     | -                           |
| 2.4 GHz WLAN       | 000323/8           | 000410/3                     | -                           |
| 5 GHz WLAN         | 000323/8           | 000815/3                     | -                           |

|  |   |                                     |   |  |
|--|---|-------------------------------------|---|--|
| FCC ID: A3LSMT331                        |  <b>PCTEST</b><br>ENGINEERING LABORATORY, INC. | <b>SAR EVALUATION REPORT</b>        |  | <b>Reviewed by:</b><br>Quality Manager |
| <b>Document S/N:</b><br>0Y1312302508.A3L | <b>Test Dates:</b><br>01/06/2014-01/24/2014   | <b>DUT Type:</b><br>Portable Tablet |   | Page 7 of 47                           |

## 2 INTRODUCTION

The FCC and Industry Canada have adopted the guidelines for evaluating the environmental effects of radio frequency (RF) radiation in ET Docket 93-62 on Aug. 6, 1996 and Health Canada Safety Code 6 to protect the public and workers from the potential hazards of RF emissions due to FCC-regulated portable devices. [1]

The safety limits used for the environmental evaluation measurements are based on the criteria published by the American National Standards Institute (ANSI) for localized specific absorption rate (SAR) in IEEE/ANSI C95.1-1992 Standard for Safety Levels with Respect to Human Exposure to Radio Frequency Electromagnetic Fields, 3 kHz to 300 GHz [3] and Health Canada RF Exposure Guidelines Safety Code 6 [22]. The measurement procedure described in IEEE/ANSI C95.3-2002 Recommended Practice for the Measurement of Potentially Hazardous Electromagnetic Fields - RF and Microwave [4] is used for guidance in measuring the Specific Absorption Rate (SAR) due to the RF radiation exposure from the Equipment Under Test (EUT). These criteria for SAR evaluation are similar to those recommended by the International Committee for Non-Ionizing Radiation Protection (ICNIRP) in Biological Effects and Exposure Criteria for Radiofrequency Electromagnetic Fields," Report No. Vol 74. SAR is a measure of the rate of energy absorption due to exposure to an RF transmitting source. SAR values have been related to threshold levels for potential biological hazards.

### 2.1 SAR Definition

Specific Absorption Rate is defined as the time derivative (rate) of the incremental energy (dU) absorbed by (dissipated in) an incremental mass (dm) contained in a volume element (dV) of a given density ( $\rho$ ). It is also defined as the rate of RF energy absorption per unit mass at a point in an absorbing body (see Equation 2-1).

**Equation 2-1**  
**SAR Mathematical Equation**

$$SAR = \frac{d}{dt} \left( \frac{dU}{dm} \right) = \frac{d}{dt} \left( \frac{dU}{\rho dv} \right)$$



**SAR is expressed in units of Watts per Kilogram (W/kg).**

$$SAR = \frac{\sigma \cdot E^2}{\rho}$$

where:

- $\sigma$  = conductivity of the tissue-simulating material (S/m)
- $\rho$  = mass density of the tissue-simulating material ( $\text{kg/m}^3$ )
- E = Total RMS electric field strength (V/m)

NOTE: The primary factors that control rate of energy absorption were found to be the wavelength of the incident field in relation to the dimensions and geometry of the irradiated organism, the orientation of the organism in relation to the polarity of field vectors, the presence of reflecting surfaces, and whether conductive contact is made by the organism with a ground plane.[6]

|  |   |                                     |   |  |
|--|---|-------------------------------------|---|--|
| FCC ID: A3LSMT331                        |  <b>PCTEST</b><br>ENGINEERING LABORATORY, INC. | <b>SAR EVALUATION REPORT</b>        |  | <b>Reviewed by:</b><br>Quality Manager |
| <b>Document S/N:</b><br>0Y1312302508.A3L | <b>Test Dates:</b><br>01/06/2014-01/24/2014   | <b>DUT Type:</b><br>Portable Tablet | Page 8 of 47  |  |

## 3 DOSIMETRIC ASSESSMENT

### 3.1 Measurement Procedure

The evaluation was performed using the following procedure compliant to FCC KDB Publication 865664 D01v01 and IEEE 1528-2013:

1. The SAR distribution at the exposed side of the head or body was measured at a distance no greater than 5.0 mm from the inner surface of the shell. The area covered the entire dimension of the device-head and body interface and the horizontal grid resolution was determined per FCC KDB Publication 865664 D01v01 (See Table 3-1) and IEEE 1528-2013.
2. The point SAR measurement was taken at the maximum SAR region determined from Step 1 to enable the monitoring of SAR fluctuations/drifts during the 1g/10g cube evaluation. SAR at this fixed point was measured and used as a reference value.
3. Based on the area scan data, the peak of the region with maximum SAR was determined by spline interpolation. Around this point, a volume was assessed according to the measurement resolution and volume size requirements of FCC KDB Publication 865664 D01v01 (See Table 3-1) and IEEE 1528-2013. On the basis of this data set, the spatial peak SAR value was evaluated with the following procedure (see references or the DASYS manual online for more details):
  - a. SAR values at the inner surface of the phantom are extrapolated from the measured values along the line away from the surface with spacing no greater than that in Table 3-1. The extrapolation was based on a least-squares algorithm. A polynomial of the fourth order was calculated through the points in the z-axis (normal to the phantom shell).
  - b. After the maximum interpolated values were calculated between the points in the cube, the SAR was averaged over the spatial volume (1g or 10g) using a 3D-Spline interpolation algorithm. The 3D-spline is composed of three one-dimensional splines with the “Not a knot” condition (in x, y, and z directions). The volume was then integrated with the trapezoidal algorithm. One thousand points (10 x 10 x 10) were obtained through interpolation, in order to calculate the averaged SAR.
  - c. All neighboring volumes were evaluated until no neighboring volume with a higher average value was found.
4. The SAR reference value, at the same location as step 2, was re-measured after the zoom scan was complete to calculate the SAR drift. If the drift deviated by more than 5%, the SAR test and drift measurements were repeated.

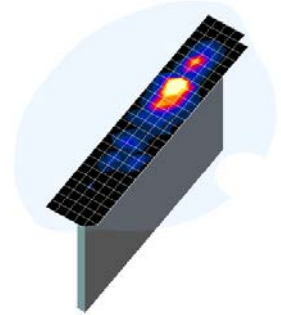



**Figure 3-1**  
Sample SAR Area Scan

**Table 3-1**  
Area and Zoom Scan Resolutions per FCC KDB Publication 865664 D01v01\*

| Frequency | Maximum Area Scan Resolution (mm)<br>( $\Delta x_{area}, \Delta y_{area}$ ) | Maximum Zoom Scan Resolution (mm)<br>( $\Delta x_{zoom}, \Delta y_{zoom}$ ) | Maximum Zoom Scan Spatial Resolution (mm) |                        |                               | Minimum Zoom Scan Volume (mm)<br>(x,y,z) |
|-----------|---|---|---|------------------------|-------------------------------|--|
|           |   |   | Uniform Grid<br>$\Delta z_{zoom}(n)$      | Graded Grid            |                               |  |
|           |   |   |   | $\Delta z_{zoom}(1)^*$ | $\Delta z_{zoom}(n-1)^*$      |  |
| ≤ 2 GHz   | ≤ 15  | ≤ 8   | ≤ 5                                       | ≤ 4                    | ≤ 1.5* $\Delta z_{zoom}(n-1)$ | ≥ 30                                     |
| 2-3 GHz   | ≤ 12  | ≤ 5   | ≤ 5                                       | ≤ 4                    | ≤ 1.5* $\Delta z_{zoom}(n-1)$ | ≥ 30                                     |
| 3-4 GHz   | ≤ 12  | ≤ 5   | ≤ 4                                       | ≤ 3                    | ≤ 1.5* $\Delta z_{zoom}(n-1)$ | ≥ 28                                     |
| 4-5 GHz   | ≤ 10  | ≤ 4   | ≤ 3                                       | ≤ 2.5                  | ≤ 1.5* $\Delta z_{zoom}(n-1)$ | ≥ 25                                     |
| 5-6 GHz   | ≤ 10  | ≤ 4   | ≤ 2                                       | ≤ 2                    | ≤ 1.5* $\Delta z_{zoom}(n-1)$ | ≥ 22                                     |

\*Also compliant to IEEE 1528-2013 Table 6

|                                   |   |                              |   |                                 |
|-----------------------------------|---|------------------------------|---|---------------------------------|
| FCC ID: A3LSMT331                 |  | <b>SAR EVALUATION REPORT</b> |  | Reviewed by:<br>Quality Manager |
| Document S/N:<br>0Y1312302508.A3L | Test Dates:<br>01/06/2014-01/24/2014  | DUT Type:<br>Portable Tablet |   | Page 9 of 47                    |

# 4 DEFINITION OF REFERENCE POINTS

## 4.1 EAR REFERENCE POINT

Figure 4-2 shows the front, back and side views of the SAM Twin Phantom. The point “M” is the reference point for the center of the mouth, “LE” is the left ear reference point (ERP), and “RE” is the right ERP. The ERP is 15mm posterior to the entrance to the ear canal (EEC) along the B-M line (Back-Mouth), as shown in Figure 4-1. The plane passing through the two ear canals and M is defined as the Reference Plane. The line N-F (Neck-Front), also called the Reference Pivoting Line, is not perpendicular to the reference plane (see Figure 4-1). Line B-M is perpendicular to the N-F line. Both N-F and B-M lines are marked on the external phantom shell to facilitate handset positioning [5].

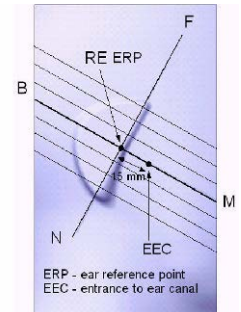

**Figure 4-1**  
Close-Up Side view of ERP

## 4.2 HANDSET REFERENCE POINTS



Two imaginary lines on the handset were established: the vertical centerline and the horizontal line. The test device was placed in a normal operating position with the acoustic output located along the “vertical centerline” on the front of the device aligned to the “ear reference point” (See Figure 4-3). The acoustic output was then located at the same level as the center of the ear reference point. The test device was positioned so that the “vertical centerline” was bisecting the front surface of the handset at its top and bottom edges, positioning the “ear reference point” on the outer surface of the both the left and right head phantoms on the ear reference point.

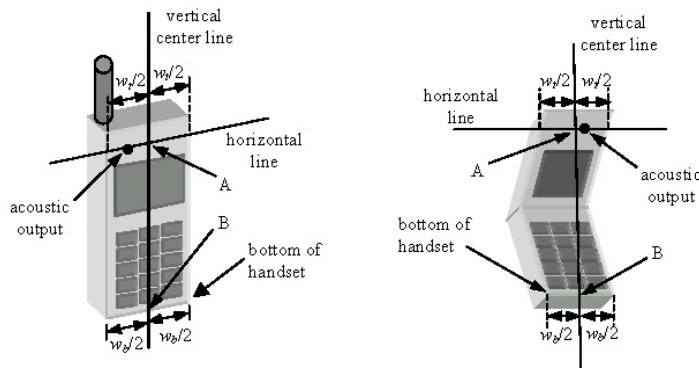

**Figure 4-2**  
Front, back and side view of SAM Twin Phantom



**Figure 4-3**  
Handset Vertical Center & Horizontal Line Reference Points

|                                   |  |                              |   |                                 |
|-----------------------------------|--|------------------------------|---|---------------------------------|
| FCC ID: A3LSMT331                 |  PCTEST<br>ENGINEERING LABORATORY, INC. | SAR EVALUATION REPORT        |  | Reviewed by:<br>Quality Manager |
| Document S/N:<br>0Y1312302508.A3L | Test Dates:<br>01/06/2014-01/24/2014   | DUT Type:<br>Portable Tablet |   | Page 10 of 47                   |

## 5 TEST CONFIGURATION POSITIONS FOR HANDSETS

### 5.1 Device Holder

The device holder is made out of low-loss POM material having the following dielectric parameters: relative permittivity  $\epsilon = 3$  and loss tangent  $\delta = 0.02$ .

### 5.2 Positioning for Cheek

1. The test device was positioned with the device close to the surface of the phantom such that point A is on the (virtual) extension of the line passing through points RE and LE on the phantom (see Figure 5-1), such that the plane defined by the vertical center line and the horizontal line of the phone is approximately parallel to the sagittal plane of the phantom.

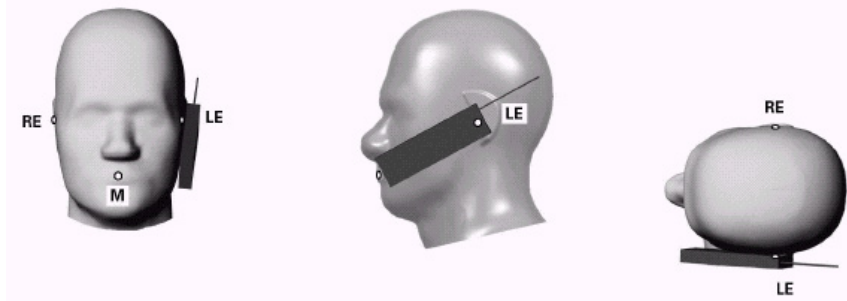



Figure 5-1 Front, Side and Top View of Cheek Position

2. The handset was translated towards the phantom along the line passing through RE & LE until the handset touches the pinna.
3. While maintaining the handset in this plane, the handset was rotated around the LE-RE line until the vertical centerline was in the reference plane.
4. The phone was then rotated around the vertical centerline until the phone (horizontal line) was symmetrical with respect to the line NF.
5. While maintaining the vertical centerline in the reference plane, keeping point A on the line passing through RE and LE, and maintaining the device contact with the ear, the device was rotated about the NF line until any point on the handset made contact with a phantom point below the ear (cheek) (See Figure 5-2).

### 5.3 Positioning for Ear / 15° Tilt

With the test device aligned in the “Cheek Position”:

1. While maintaining the orientation of the phone, the phone was retracted parallel to the reference plane far enough to enable a rotation of the phone by 15 degrees.
2. The phone was then rotated around the horizontal line by 15 degrees.
3. While maintaining the orientation of the phone, the phone was moved parallel to the reference plane until any part of the handset touched the head. (In this position, point A was located on the line RE-LE). The tilted position is obtained when the contact is on the pinna. If the contact was at any location other than the pinna, the angle of the phone would then be reduced. In this situation, the tilted position was obtained when any part of the phone was in contact of the ear as well as a second part of the phone was in contact with the head (see Figure 5-2).

|                                   |   |                              |   |                                 |
|-----------------------------------|---|------------------------------|---|---------------------------------|
| FCC ID: A3LSMT331                 |  | SAR EVALUATION REPORT        |  | Reviewed by:<br>Quality Manager |
| Document S/N:<br>0Y1312302508.A3L | Test Dates:<br>01/06/2014-01/24/2014  | DUT Type:<br>Portable Tablet |   | Page 11 of 47                   |

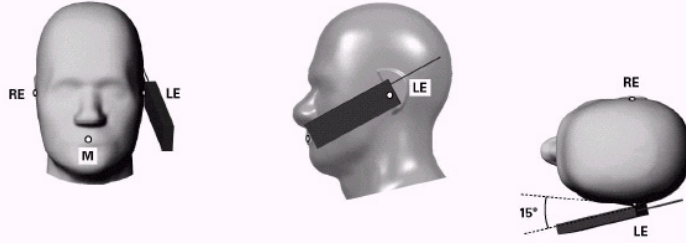

**Figure 5-2 Front, Side and Top View of Ear/15° Tilt Position**

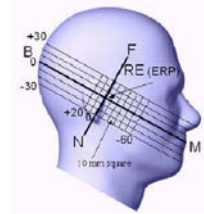

**Figure 5-3 Side view w/ relevant markings**

#### 5.4 SAR Testing for Tablet per KDB Publication 616217 D04v01



This device can be used also in full sized tablet exposure conditions, due to its size. Per FCC KDB 616217, the back surface and edges of the tablet should be tested for SAR compliance with the tablet touching the phantom. The SAR Exclusion Threshold in KDB 447498 D01v05 can be applied to determine SAR test exclusion for adjacent edge configurations. The closest distance from the antenna to an adjacent tablet edge is used to determine if SAR testing is required for the adjacent edges, with the adjacent edge positioned against the phantom and the edge containing the antenna positioned perpendicular to the phantom.

#### 5.5 Additional Test Positions due to Proximity Sensor Considerations

This device uses a proximity sensor to reduce voice/data powers in tablet-device use conditions.

While the device is touching the user on the antenna, the proximity sensor activates and thus reduces the maximum output power allowed. However, when the device is moved beyond the sensor triggering distance, the sensors de-activate and thus maximum output power is no longer limited. Therefore, an additional exposure condition is needed in the vicinity of the triggering distance to ensure SAR is compliant when the device is allowed to operate at a non-reduced output power level. FCC KDB 616217 D04 Section 6 was used as a guideline for selecting SAR test distances for this device at these additional exposure conditions. Since the capacitive proximity sensor activation distance for the back side of the device is 13 mm, a conservative distance of 12 mm was tested for SAR on the back side at maximum power. Since the capacitive proximity sensor activation distance for the top edge of the device is 10 mm, a conservative distance of 9 mm was tested for SAR on the top edge at maximum power. Sensor triggering distance summary data is included in Appendix G. The capacitive proximity sensor does not trigger power reduction from the bottom edge, left edge or right edge of the device.

The sensor is designed to support sufficient detection range and sensitivity to cover regions of the sensors in all applicable directions since the sensor entirely covers the antenna.

|                                   |   |                              |   |                                 |
|-----------------------------------|---|------------------------------|---|---------------------------------|
| FCC ID: A3LSMT331                 |  | SAR EVALUATION REPORT        |  | Reviewed by:<br>Quality Manager |
| Document S/N:<br>0Y1312302508.A3L | Test Dates:<br>01/06/2014-01/24/2014  | DUT Type:<br>Portable Tablet |   | Page 12 of 47                   |

## 6 RF EXPOSURE LIMITS

### 6.1 Uncontrolled Environment

UNCONTROLLED ENVIRONMENTS are defined as locations where there is the exposure of individuals who have no knowledge or control of their exposure. The general population/uncontrolled exposure limits are applicable to situations in which the general public may be exposed or in which persons who are exposed as a consequence of their employment may not be made fully aware of the potential for exposure or cannot exercise control over their exposure. Members of the general public would come under this category when exposure is not employment-related; for example, in the case of a wireless transmitter that exposes persons in its vicinity.



### 6.2 Controlled Environment

CONTROLLED ENVIRONMENTS are defined as locations where there is exposure that may be incurred by persons who are aware of the potential for exposure, (i.e. as a result of employment or occupation). In general, occupational/controlled exposure limits are applicable to situations in which persons are exposed as a consequence of their employment, who have been made fully aware of the potential for exposure and can exercise control over their exposure. This exposure category is also applicable when the exposure is of a transient nature due to incidental passage through a location where the exposure levels may be higher than the general population/uncontrolled limits, but the exposed person is fully aware of the potential for exposure and can exercise control over his or her exposure by leaving the area or by some other appropriate means.

**Table 6-1**  
**SAR Human Exposure Specified in ANSI/IEEE C95.1-1992 and Health Canada Safety Code 6**

| HUMAN EXPOSURE LIMITS   |   |   |
|---|---|---|
|   | UNCONTROLLED ENVIRONMENT<br><i>General Population</i><br>(W/kg) or (mW/g) | CONTROLLED ENVIRONMENT<br><i>Occupational</i><br>(W/kg) or (mW/g) |
| <b>Peak Spatial Average SAR</b><br>Head                             | 1.6   | 8.0   |
| <b>Whole Body SAR</b>   | 0.08  | 0.4   |
| <b>Peak Spatial Average SAR</b><br>Hands, Feet, Ankle, Wrists, etc. | 4.0   | 20  |

1. The Spatial Peak value of the SAR averaged over any 1 gram of tissue (defined as a tissue volume in the shape of a cube) and over the appropriate averaging time.
2. The Spatial Average value of the SAR averaged over the whole body.
3. The Spatial Peak value of the SAR averaged over any 10 grams of tissue (defined as a tissue volume in the shape of a cube) and over the appropriate averaging time.

|                                   |   |                              |   |                                 |
|-----------------------------------|---|------------------------------|---|---------------------------------|
| FCC ID: A3LSMT331                 |  | SAR EVALUATION REPORT        |  | Reviewed by:<br>Quality Manager |
| Document S/N:<br>0Y1312302508.A3L | Test Dates:<br>01/06/2014-01/24/2014  | DUT Type:<br>Portable Tablet |   | Page 13 of 47                   |

## 7 FCC MEASUREMENT PROCEDURES

Power measurements were performed using a base station simulator under digital average power.

### 7.1 Measured and Reported SAR

Per FCC KDB Publication 447498 D01v05, When SAR is not measured at the maximum power level allowed for production units, the results must be scaled to the maximum tune-up tolerance limit according to the power applied to the individual channels tested to determine compliance. For simultaneous transmission, the measured aggregate SAR must be scaled according to the sum of the differences between the maximum tune-up tolerance and actual power used to test each transmitter. When SAR is measured at or scaled to the maximum tune-up tolerance limit, the results are referred to as *reported* SAR. The highest *reported* SAR results are identified on the grant of equipment authorization according to procedures in KDB 690783 D01v01r02.

### 7.2 Procedures Used to Establish RF Signal for SAR

The following procedures are according to FCC KDB Publication 941225 D01 "SAR Measurement Procedures for 3G Devices" v02, October 2007.

The device was placed into a simulated call using a base station simulator in a RF shielded chamber. Establishing connections in this manner ensure a consistent means for testing SAR and are recommended for evaluating SAR [4]. Devices under test were evaluated prior to testing, with a fully charged battery and were configured to operate at maximum output power. In order to verify that the device was tested throughout the SAR test at maximum output power, the SAR measurement system measures a "point SAR" at an arbitrary reference point at the start and end of the 1 gram SAR evaluation, to assess for any power drifts during the evaluation. If the power drift deviated by more than 5%, the SAR test and drift measurements were repeated.

### 7.3 SAR Measurement Conditions for UMTS



#### 7.3.1 Output Power Verification

Maximum output power is measured on the High, Middle and Low channels for each applicable transmission band according to the general descriptions in section 5.2 of 3GPP TS 34.121, using the appropriate RMC or AMR with TPC (transmit power control) set to all "1s".

Maximum output power is verified on the High, Middle and Low channels according to the general descriptions in section 5.2 of 3GPP TS 34.121 (release 5), using the appropriate RMC with TPC (transmit power control) set to all "1s" or applying the required inner loop power control procedures to maintain maximum output power while HSUPA is active. Results for all applicable physical channel configurations (DPCCH, DPDCHe and spreading codes, HS-DPCCH etc) are tabulated in this test report. All configurations that are not supported by the DUT or cannot be measured due to technical or equipment limitations are identified.

#### 7.3.2 Head SAR Measurements for Handsets

SAR for head exposure configurations is measured using the 12.2 kbps RMC with TPC bits configured to all "1s". SAR in AMR configurations is not required when the maximum average output of each RF channel for 12.2 kbps AMR is less than 0.25 dB higher than that measured in 12.2 kbps RMC. Otherwise, SAR is measured on the maximum output channel in 12.2 AMR with a

|                                   |  |                              |   |                                 |
|-----------------------------------|--|------------------------------|---|---------------------------------|
| FCC ID: A3LSMT331                 |  PCTEST<br>ENGINEERING LABORATORY, INC. | SAR EVALUATION REPORT        |  | Reviewed by:<br>Quality Manager |
| Document S/N:<br>0Y1312302508.A3L | Test Dates:<br>01/06/2014-01/24/2014   | DUT Type:<br>Portable Tablet |   | Page 14 of 47                   |

3.4 kbps SRB (signaling radio bearer) using the exposure configuration that resulted in the highest SAR for that RF channel in the 12.2 kbps RMC mode.

### 7.3.3 Body SAR Measurements

SAR for body exposure configurations is measured using the 12.2 kbps RMC with the TPC bits all "1s".

### 7.3.4 Procedures Used to Establish RF Signal for SAR HSDPA Data Devices

The following procedures are applicable to HSDPA data devices operating under 3GPP Release 5. Body exposure conditions are typically applicable to these devices, including handsets and data modems operating in various electronic devices. HSDPA operates in conjunction with UMTS and requires an active DPCCH. The default test configuration is to measure SAR in UMTS without HSDPA, with an established radio link between the DUT and a communication test set with 12.2 kbps RMC mode configured in Test Loop Mode 1; and tested with HSDPA with FRC and a 12.2 kbps RMC using the highest SAR configuration in UMTS. SAR is selectively confirmed for other physical channel configurations according to output power, exposure conditions and device operating capabilities. Maximum output power is verified according to 3GPP TS 23.121 (Release 5) and SAR must be measured according to these maximum output conditions.

| Sub-Test | $\beta_c$      | $\beta_d$      | $\beta_d$ (SF) | $\beta_c/\beta_d$ | $\beta_{HS}$ (Note 1, Note 2) | CM (dB) (Note 3) | MPR (dB) (Note 3) |
|----------|----------------|----------------|----------------|-------------------|-------------------------------|------------------|-------------------|
| 1        | 2/15           | 15/15          | 64             | 2/15              | 4/15                          | 0.0              | 0.0               |
| 2        | 12/15 (Note 4) | 15/15 (Note 4) | 64             | 12/15 (Note 4)    | 24/15                         | 1.0              | 0.0               |
| 3        | 15/15          | 8/15           | 64             | 15/8              | 30/15                         | 1.5              | 0.5               |
| 4        | 15/15          | 4/15           | 64             | 15/4              | 30/15                         | 1.5              | 0.5               |



Note 1:  $\Delta_{ACK}$ ,  $\Delta_{NACK}$  and  $\Delta_{CQI} = 8 \Leftrightarrow A_{HS} = \beta_{HS}/\beta_c = 30/15 \Leftrightarrow \beta_{HS} = 30/15 * \beta_c$ .  
 Note 2: For the HS-DPCCH power mask requirement test in clause 5.2C, 5.7A, and the Error Vector Magnitude (EVM) with HS-DPCCH test in clause 5.13.1A, and HSDPA EVM with phase discontinuity in clause 5.13.1AA,  $\Delta_{ACK}$  and  $\Delta_{NACK} = 8$  ( $A_{HS} = 30/15$ ) with  $\beta_{HS} = 30/15 * \beta_c$ , and  $\Delta_{CQI} = 7$  ( $A_{HS} = 24/15$ ) with  $\beta_{HS} = 24/15 * \beta_c$ .  
 Note 3: CM = 1 for  $\beta_c/\beta_d = 12/15$ ,  $\beta_{HS}/\beta_c = 24/15$ . For all other combinations of DPDCH, DPCCH and HS-DPCCH the MPR is based on the relative CM difference. This is applicable for only UEs that support HSDPA in release 6 and later releases.

Figure 7-1  
Table C.10.1.4 of TS 234.121-1

### 7.3.5 SAR Measurement Conditions for HSUPA Data Devices

SAR for body exposure configurations are measured according to the 'Body SAR Measurements' procedures in the 'WCDMA Handsets' section of the KDB 941225 D01 FCC 3G document. In addition, Body SAR is also measured for HSPA when the maximum average output of each RF channel with HSPA active is at least ¼ dB higher of that measured without HSPA in 12.2 kbps RMC mode or the maximum SAR for 12.2 kbps RMC is above 75% of the SAR limit. Body SAR for HSPA is measured with E-DCH Sub-test 5, using H-Set 1 and QPSK for FRC and a 12.2 kbps RMC configured in Test Loop Mode 1 with power control algorithm 2, according to the highest body SAR configuration in 12.2 kbps RMC without HSPA. When VOIP is applicable for head exposure, SAR is not required when the maximum output of each RF channel with HSPA is less than ¼ dB higher than that measured using 12.2 kbps RMC; otherwise, the same HSPA configuration used for body measurements should be used to test for head exposure.

Due to inner loop power control requirements in HSPA, a commercial communication test set should be used for the output power and SAR tests. The 12.2 kbps RMC, FRC H-set 1 and EDCH

|                                   |  |                              |   |                                 |
|-----------------------------------|--|------------------------------|---|---------------------------------|
| FCC ID: A3LSMT331                 |  PCTEST<br>ENGINEERING LABORATORY, INC. | SAR EVALUATION REPORT        |  | Reviewed by:<br>Quality Manager |
| Document S/N:<br>0Y1312302508.A3L | Test Dates:<br>01/06/2014-01/24/2014   | DUT Type:<br>Portable Tablet |   | Page 15 of 47                   |

configurations for HSPA should be configured according to the  $\beta$  values indicated below as well as other applicable procedures described in the 'WCDMA Handset' and 'Release 5 HSDPA Data Devices' sections of the FCC 3G document.

| Sub-test | $\beta_c$            | $\beta_d$            | $\beta_d$ (SF) | $\beta_c/\beta_d$    | $\beta_{1s}^{(1)}$ | $\beta_{ec}$ | $\beta_{ed}$                                 | $\beta_{ed}$ (SF) | $\beta_{ed}$ (codes) | CM <sup>(2)</sup> (dB) | MPR (dB) | AG <sup>(4)</sup> Index | E-TFCI |
|----------|----------------------|----------------------|----------------|----------------------|--------------------|--------------|--|-------------------|----------------------|------------------------|----------|-------------------------|--------|
| 1        | 11/15 <sup>(3)</sup> | 15/15 <sup>(3)</sup> | 64             | 11/15 <sup>(3)</sup> | 22/15              | 209/225      | 1039/225                                     | 4                 | 1                    | 1.0                    | 0.0      | 20                      | 75     |
| 2        | 6/15                 | 15/15                | 64             | 6/15                 | 12/15              | 12/15        | 94/75  | 4                 | 1                    | 3.0                    | 2.0      | 12                      | 67     |
| 3        | 15/15                | 9/15                 | 64             | 15/9                 | 30/15              | 30/15        | $\beta_{ed1}: 47/15$<br>$\beta_{ed2}: 47/15$ | 4                 | 2                    | 2.0                    | 1.0      | 15                      | 92     |
| 4        | 2/15                 | 15/15                | 64             | 2/15                 | 4/15               | 2/15         | 56/75  | 4                 | 1                    | 3.0                    | 2.0      | 17                      | 71     |
| 5        | 15/15 <sup>(4)</sup> | 15/15 <sup>(4)</sup> | 64             | 15/15 <sup>(4)</sup> | 30/15              | 24/15        | 134/15                                       | 4                 | 1                    | 1.0                    | 0.0      | 21                      | 81     |

Note 1:  $\Delta_{ACK}$ ,  $\Delta_{NACK}$  and  $\Delta_{CQI} = 8 \Leftrightarrow A_{1s} = \beta_{1s}/\beta_c = 30/15 \Leftrightarrow \beta_{1s} = 30/15 * \beta_c$ .  
 Note 2: CM = 1 for  $\beta_c/\beta_d = 12/15$ ,  $\beta_{1s}/\beta_c = 24/15$ . For all other combinations of DPDCH, DPCCCH, HS-DPCCH, E-DPDCH and E-DPCCH the MPR is based on the relative CM difference.  
 Note 3: For subtest 1 the  $\beta_c/\beta_d$  ratio of 11/15 for the TFC during the measurement period (TF1, TF0) is achieved by setting the signaled gain factors for the reference TFC (TF1, TF1) to  $\beta_c = 10/15$  and  $\beta_d = 15/15$ .  
 Note 4: For subtest 5 the  $\beta_c/\beta_d$  ratio of 15/15 for the TFC during the measurement period (TF1, TF0) is achieved by setting the signaled gain factors for the reference TFC (TF1, TF1) to  $\beta_c = 14/15$  and  $\beta_d = 15/15$ .  
 Note 5: Testing UE using E-DPDCH Physical Layer category 1 Sub-test 3 is not required according to TS 25.306 Table 5.1g.  
 Note 6:  $\beta_{ed}$  can not be set directly; it is set by Absolute Grant Value.

## 7.4 SAR Testing with 802.11 Transmitters

Normal network operating configurations are not suitable for measuring the SAR of 802.11 a/b/g/n transmitters. Unpredictable fluctuations in network traffic and antenna diversity conditions can introduce undesirable variations in SAR results. The SAR for these devices should be measured using chipset based test mode software to ensure the results are consistent and reliable. See KDB Publication 248227 D01v01r02 for more details.

### 7.4.1 General Device Setup



Chipset based test mode software is hardware dependent and generally varies among manufacturers. The device operating parameters established in test mode for SAR measurements must be identical to those programmed in production units, including output power levels, amplifier gain settings and other RF performance tuning parameters. The test frequencies should correspond to actual channel frequencies defined for domestic use. SAR for devices with switched diversity should be measured with only one antenna transmitting at a time during each SAR measurement, according to a fixed modulation and data rate. The same data pattern should be used for all measurements.

### 7.4.2 Frequency Channel Configurations [24]

For 2.4 GHz, the highest average RF output power channel between the low, mid and high channel at the lowest data rate was selected for SAR evaluation in 802.11b mode. 802.11g/n modes and higher data rates for 802.11b were additionally evaluated for SAR if the output power of the respective mode was 0.25 dB or higher than the powers of the SAR configurations tested in the 802.11b mode.

For 5 GHz, the highest average RF output power channel across the default test channels at the lowest data rate was selected for SAR evaluation in 802.11a. When the adjacent channels are higher in power than the default channels, these "required channels" were considered instead of the default channels for SAR testing. 802.11n modes and higher data rates for 802.11a/n were evaluated only if the respective mode was higher than 0.25 dB or more than the 802.11a mode.

If the maximum extrapolated peak SAR of the zoom scan for the highest output channel was less than 1.6 W/kg and if the 1g averaged SAR was less than 0.8 W/kg, SAR testing was not required for the other test channels in the band.



|                                   |   |                              |   |                                 |
|-----------------------------------|---|------------------------------|---|---------------------------------|
| FCC ID: A3LSMT331                 |  | SAR EVALUATION REPORT        |  | Reviewed by:<br>Quality Manager |
| Document S/N:<br>0Y1312302508.A3L | Test Dates:<br>01/06/2014-01/24/2014  | DUT Type:<br>Portable Tablet |   | Page 16 of 47                   |

# 8 RF CONDUCTED POWERS

## 8.1 GSM Conducted Powers

**Table 9-1**  
**Maximum GSM/GPRS/EDGE Average RF Conducted Powers**  
**(Representing Capacitive Sensor Not Active)**

|                 |                       | Maximum Burst-Averaged Output Power            |                            |                            |                            |                            |                            |                            |                            |                            |
|-----------------|-----------------------|--|----------------------------|----------------------------|----------------------------|----------------------------|----------------------------|----------------------------|----------------------------|----------------------------|
|                 |                       | Voice  | GPRS/EDGE Data (GMSK)      |                            |                            |                            | EDGE Data (8-PSK)          |                            |                            |                            |
| Band            | Channel               | GSM [dBm]<br>CS<br>(1 Slot)                    | GPRS [dBm]<br>1 Tx<br>Slot | GPRS [dBm]<br>2 Tx<br>Slot | GPRS [dBm]<br>3 Tx<br>Slot | GPRS [dBm]<br>4 Tx<br>Slot | EDGE [dBm]<br>1 Tx<br>Slot | EDGE [dBm]<br>2 Tx<br>Slot | EDGE [dBm]<br>3 Tx<br>Slot | EDGE [dBm]<br>4 Tx<br>Slot |
| <b>GSM 850</b>  | 128                   | 32.39  | 32.27                      | 29.98                      | <b>28.45</b>               | 26.96                      | 26.70                      | 25.50                      | 25.07                      | 22.90                      |
|                 | 190                   | 32.37  | 32.27                      | 30.03                      | <b>28.50</b>               | 26.95                      | 26.71                      | 25.73                      | 25.10                      | 22.86                      |
|                 | 251                   | 32.40  | 32.31                      | 29.98                      | <b>28.45</b>               | 26.96                      | 26.81                      | 25.95                      | 24.93                      | 22.85                      |
| <b>GSM 1900</b> | 512                   | 29.15  | 29.30                      | 27.00                      | <b>25.72</b>               | 24.75                      | 25.30                      | 24.72                      | 23.75                      | 21.57                      |
|                 | 661                   | 29.20  | 29.09                      | 27.93                      | <b>25.55</b>               | 24.80                      | 25.41                      | 24.60                      | 24.10                      | 21.53                      |
|                 | 810                   | 29.08  | 29.53                      | 27.53                      | <b>25.40</b>               | 24.50                      | 24.92                      | 24.67                      | 23.82                      | 21.77                      |
|                 |                       | Calculated Maximum Frame-Averaged Output Power |                            |                            |                            |                            |                            |                            |                            |                            |
|                 |                       | Voice  | GPRS/EDGE Data (GMSK)      |                            |                            |                            | EDGE Data (8-PSK)          |                            |                            |                            |
| Band            | Channel               | GSM [dBm]<br>CS<br>(1 Slot)                    | GPRS [dBm]<br>1 Tx<br>Slot | GPRS [dBm]<br>2 Tx<br>Slot | GPRS [dBm]<br>3 Tx<br>Slot | GPRS [dBm]<br>4 Tx<br>Slot | EDGE [dBm]<br>1 Tx<br>Slot | EDGE [dBm]<br>2 Tx<br>Slot | EDGE [dBm]<br>3 Tx<br>Slot | EDGE [dBm]<br>4 Tx<br>Slot |
| <b>GSM 850</b>  | 128                   | 23.36  | 23.24                      | 23.96                      | <b>24.19</b>               | 23.95                      | 17.67                      | 19.48                      | 20.81                      | 19.89                      |
|                 | 190                   | 23.34  | 23.24                      | 24.01                      | <b>24.24</b>               | 23.94                      | 17.68                      | 19.71                      | 20.84                      | 19.85                      |
|                 | 251                   | 23.37  | 23.28                      | 23.96                      | <b>24.19</b>               | 23.95                      | 17.78                      | 19.93                      | 20.67                      | 19.84                      |
| <b>GSM 1900</b> | 512                   | 20.12  | 20.27                      | 20.98                      | <b>21.46</b>               | 21.74                      | 16.27                      | 18.70                      | 19.49                      | 18.56                      |
|                 | 661                   | 20.17  | 20.06                      | 21.91                      | <b>21.29</b>               | 21.79                      | 16.38                      | 18.58                      | 19.84                      | 18.52                      |
|                 | 810                   | 20.05  | 20.50                      | 21.51                      | <b>21.14</b>               | 21.49                      | 15.89                      | 18.65                      | 19.56                      | 18.76                      |
| <b>GSM 850</b>  | Frame<br>Avg.Targets: | 23.97  | 23.97                      | 23.98                      | <b>24.24</b>               | 23.49                      | 17.47                      | 19.98                      | 21.74                      | 19.49                      |
| <b>GSM 1900</b> |                       | 20.97  | 20.97                      | 21.98                      | <b>21.74</b>               | 21.49                      | 15.97                      | 18.98                      | 20.24                      | 18.49                      |

|                                   |   |                              |   |                                 |
|-----------------------------------|---|------------------------------|---|---------------------------------|
| FCC ID: A3LSMT331                 |  <b>PCTEST</b><br>ENGINEERING LABORATORY, INC. | <b>SAR EVALUATION REPORT</b> |  | Reviewed by:<br>Quality Manager |
| Document S/N:<br>0Y1312302508.A3L | Test Dates:<br>01/06/2014-01/24/2014  | DUT Type:<br>Portable Tablet |   | Page 17 of 47                   |

**Table 9-2  
Reduced GSM/GPRS/EDGE Average RF Conducted Powers  
(Representing Capacitive Sensor Active)**

|                 |                           | Maximum Burst-Averaged Output Power            |                            |                            |                            |                            |                            |                            |                            |                            |
|-----------------|---------------------------|--|----------------------------|----------------------------|----------------------------|----------------------------|----------------------------|----------------------------|----------------------------|----------------------------|
|                 |                           | Voice  | GPRS/EDGE Data (GMSK)      |                            |                            |                            | EDGE Data (8-PSK)          |                            |                            |                            |
| Band            | Channel                   | GSM [dBm]<br>CS<br>(1 Slot)                    | GPRS [dBm]<br>1 Tx<br>Slot | GPRS [dBm]<br>2 Tx<br>Slot | GPRS [dBm]<br>3 Tx<br>Slot | GPRS [dBm]<br>4 Tx<br>Slot | EDGE [dBm]<br>1 Tx<br>Slot | EDGE [dBm]<br>2 Tx<br>Slot | EDGE [dBm]<br>3 Tx<br>Slot | EDGE [dBm]<br>4 Tx<br>Slot |
| <b>GSM 850</b>  | 128                       | 29.54  | 29.47                      | 26.73                      | <b>25.68</b>               | 23.68                      | 25.42                      | 25.26                      | 25.12                      | 21.98                      |
|                 | 190                       | 29.44  | 29.51                      | 26.74                      | <b>25.60</b>               | 23.63                      | 25.42                      | 25.29                      | 25.13                      | 21.94                      |
|                 | 251                       | 29.56  | 29.49                      | 26.82                      | <b>25.62</b>               | 23.61                      | 25.43                      | 25.25                      | 25.02                      | 21.95                      |
| <b>GSM 1900</b> | 512                       | 22.43  | 22.47                      | 20.04                      | 17.71                      | <b>16.71</b>               | 22.37                      | 19.61                      | 17.23                      | 16.48                      |
|                 | 661                       | 22.71  | 22.74                      | 20.16                      | 17.80                      | <b>16.91</b>               | 22.42                      | 19.84                      | 17.43                      | 16.05                      |
|                 | 810                       | 22.57  | 22.63                      | 20.14                      | 17.86                      | <b>16.94</b>               | 22.40                      | 19.80                      | 17.38                      | 16.00                      |
|                 |                           | Calculated Maximum Frame-Averaged Output Power |                            |                            |                            |                            |                            |                            |                            |                            |
|                 |                           | Voice  | GPRS/EDGE Data (GMSK)      |                            |                            |                            | EDGE Data (8-PSK)          |                            |                            |                            |
| Band            | Channel                   | GSM [dBm]<br>CS<br>(1 Slot)                    | GPRS [dBm]<br>1 Tx<br>Slot | GPRS [dBm]<br>2 Tx<br>Slot | GPRS [dBm]<br>3 Tx<br>Slot | GPRS [dBm]<br>4 Tx<br>Slot | EDGE [dBm]<br>1 Tx<br>Slot | EDGE [dBm]<br>2 Tx<br>Slot | EDGE [dBm]<br>3 Tx<br>Slot | EDGE [dBm]<br>4 Tx<br>Slot |
| <b>GSM 850</b>  | 128                       | 20.51  | 20.44                      | 20.71                      | <b>21.42</b>               | 20.67                      | 16.39                      | 19.24                      | 20.86                      | 18.97                      |
|                 | 190                       | 20.41  | 20.48                      | 20.72                      | <b>21.34</b>               | 20.62                      | 16.39                      | 19.27                      | 20.87                      | 18.93                      |
|                 | 251                       | 20.53  | 20.46                      | 20.80                      | <b>21.36</b>               | 20.60                      | 16.40                      | 19.23                      | 20.76                      | 18.94                      |
| <b>GSM 1900</b> | 512                       | 13.40  | 13.44                      | 14.02                      | 13.45                      | <b>13.70</b>               | 13.34                      | 13.59                      | 12.97                      | 13.47                      |
|                 | 661                       | 13.68  | 13.71                      | 14.14                      | 13.54                      | <b>13.90</b>               | 13.39                      | 13.82                      | 13.17                      | 13.04                      |
|                 | 810                       | 13.54  | 13.60                      | 14.12                      | 13.60                      | <b>13.93</b>               | 13.37                      | 13.78                      | 13.12                      | 12.99                      |
| <b>GSM 850</b>  | <b>Frame Avg. Targets</b> | 20.97  | 20.97                      | 20.48                      | <b>21.24</b>               | 20.49                      | 15.97                      | 18.98                      | 20.74                      | 19.49                      |
| <b>GSM 1900</b> |                           | 13.97  | 13.97                      | 14.48                      | 14.24                      | <b>14.49</b>               | 12.97                      | 13.48                      | 13.74                      | 13.99                      |

Notes:

- Both burst-averaged and calculated frame-averaged powers are included. Frame-averaged power was calculated from the measured burst-averaged power by converting the slot powers into linear units and calculating the energy over 8 timeslots.
- Per October 2013 TCB Workshop Notes, the source-based frame-averaged output power was evaluated for all GPRS/EDGE slot configurations. The configuration with the highest target frame averaged output power was evaluated for body SAR. When the maximum frame-averaged powers are equivalent across two or more slots (within 0.25 dB), the configuration with the most number of time slots was tested.
- GPRS/EDGE (GMSK) output powers were measured with coding scheme setting of 1 (CS1) on the base station simulator. CS1 was configured to measure GPRS output power measurements and SAR to ensure GMSK modulation in the signal. Our Investigation has shown that CS1 - CS4 settings do not have any impact on the output levels or modulation in the GPRS modes.
- EDGE (8-PSK) output powers were measured with MCS7 on the base station simulator. MCS7 coding scheme was used to measure the output powers for EDGE since investigation has shown that choosing MCS7 coding scheme will ensure 8-PSK modulation. It has been shown that MCS levels that produce 8PSK modulation do not have an impact on output power.

**GSM Class: B**  
**GPRS Multislot class: 33 (Max 4 Tx uplink slots)**  
**EDGE Multislot class: 33 (Max 4 Tx uplink slots)**  
**DTM Multislot Class: N/A**



**Figure 8-1  
Power Measurement Setup**

|                                   |                                      |                              |  |                                 |
|-----------------------------------|--------------------------------------|------------------------------|--|---------------------------------|
| FCC ID: A3LSMT331                 |                                      | <b>SAR EVALUATION REPORT</b> |  | Reviewed by:<br>Quality Manager |
| Document S/N:<br>0Y1312302508.A3L | Test Dates:<br>01/06/2014-01/24/2014 | DUT Type:<br>Portable Tablet |  | Page 18 of 47                   |

## 8.2 UMTS Conducted Powers

**Table 9-3**  
**Maximum UMTS Average RF Conducted Powers**  
**(Representing Capacitive Sensor Not Active)**

| 3GPP Release Version | Mode  | 3GPP 34.121 Subtest | Cellular Band [dBm] |       |       | PCS Band [dBm] |       |       | 3GPP MPR [dB] |
|----------------------|-------|---------------------|---------------------|-------|-------|----------------|-------|-------|---------------|
|                      |       |                     | 4132                | 4183  | 4233  | 9262           | 9400  | 9538  |               |
| 99                   | WCDMA | 12.2 kbps RMC       | 22.80               | 22.91 | 23.19 | 21.54          | 21.63 | 21.50 | -             |
| 99                   |       | 12.2 kbps AMR       | 21.77               | 22.87 | 23.16 | 21.48          | 21.52 | 21.45 | -             |
| 6                    | HSDPA | Subtest 1           | 21.47               | 21.73 | 21.75 | 20.49          | 20.76 | 20.41 | 0             |
| 6                    |       | Subtest 2           | 21.39               | 21.53 | 21.59 | 20.43          | 20.53 | 20.18 | 0             |
| 6                    |       | Subtest 3           | 20.72               | 20.62 | 20.71 | 21.32          | 21.43 | 21.09 | 0.5           |
| 6                    |       | Subtest 4           | 20.57               | 20.36 | 20.88 | 21.48          | 21.35 | 21.48 | 0.5           |
| 6                    | HSUPA | Subtest 1           | 21.76               | 21.69 | 21.88 | 20.74          | 20.36 | 20.90 | 0             |
| 6                    |       | Subtest 2           | 20.31               | 20.01 | 20.79 | 19.46          | 19.35 | 19.78 | 2             |
| 6                    |       | Subtest 3           | 20.97               | 20.73 | 20.64 | 19.34          | 19.76 | 19.64 | 1             |
| 6                    |       | Subtest 4           | 19.46               | 19.42 | 19.58 | 20.03          | 19.46 | 19.25 | 2             |
| 6                    |       | Subtest 5           | 21.63               | 21.50 | 21.67 | 20.66          | 20.74 | 20.13 | 0             |

**Table 9-4**  
**Reduced UMTS Average RF Conducted Powers**  
**(Representing Capacitive Sensor Active)**

| 3GPP Release Version | Mode  | 3GPP 34.121 Subtest | Cellular Band [dBm] |       |       | PCS Band [dBm] |       |       | 3GPP MPR [dB] |
|----------------------|-------|---------------------|---------------------|-------|-------|----------------|-------|-------|---------------|
|                      |       |                     | 4132                | 4183  | 4233  | 9262           | 9400  | 9538  |               |
| 99                   | WCDMA | 12.2 kbps RMC       | 21.18               | 21.08 | 21.16 | 13.56          | 13.41 | 13.38 | -             |
| 99                   |       | 12.2 kbps AMR       | 21.10               | 21.06 | 21.22 | 13.50          | 13.44 | 13.41 | -             |
| 6                    | HSDPA | Subtest 1           | 20.13               | 20.16 | 20.23 | 12.54          | 12.40 | 12.38 | 0             |
| 6                    |       | Subtest 2           | 20.14               | 20.17 | 20.28 | 12.51          | 12.46 | 12.47 | 0             |
| 6                    |       | Subtest 3           | 19.72               | 19.74 | 19.77 | 12.02          | 11.96 | 12.07 | 0.5           |
| 6                    |       | Subtest 4           | 19.61               | 19.60 | 19.73 | 12.11          | 11.97 | 11.98 | 0.5           |
| 6                    | HSUPA | Subtest 1           | 19.52               | 19.50 | 19.93 | 11.76          | 11.75 | 11.82 | 0             |
| 6                    |       | Subtest 2           | 18.89               | 19.03 | 18.82 | 11.42          | 11.37 | 11.34 | 2             |
| 6                    |       | Subtest 3           | 19.01               | 19.23 | 18.68 | 11.28          | 11.25 | 11.32 | 1             |
| 6                    |       | Subtest 4           | 19.46               | 19.42 | 19.58 | 11.88          | 11.85 | 11.44 | 2             |
| 6                    |       | Subtest 5           | 19.68               | 19.70 | 19.69 | 11.80          | 11.94 | 12.07 | 0             |

UMTS SAR was tested under RMC 12.2 kbps with HSPA Inactive per KDB Publication 941225 D01v02. HSPA SAR was not required since the average output power of the HSPA subtests was not more than 0.25 dB higher than the RMC level and SAR was less than 1.2 W/kg.

This device does not support DC-HSDPA.

It is expected by the manufacturer that MPR for some HSPA subtests may be up to 1 dB more than specified by 3GPP, but also as low as 0 dB according to the chipset implementation in this model.



**Figure 8-2**  
**Power Measurement Setup**

|                                   |  |                              |  |                                 |
|-----------------------------------|--|------------------------------|--|---------------------------------|
| FCC ID: A3LSMT331                 | PCTEST<br>ENGINEERING LABORATORY, INC. | SAR EVALUATION REPORT        |  | Reviewed by:<br>Quality Manager |
| Document S/N:<br>0Y1312302508.A3L | Test Dates:<br>01/06/2014-01/24/2014   | DUT Type:<br>Portable Tablet |  | Page 19 of 47                   |

### 8.3 BT/WLAN Conducted Powers

**Table 8-1**  
**IEEE 802.11b Average RF Power**



| Mode    | Freq  | Channel | 802.11b (2.4 GHz) Conducted Power [dBm] |       |       |       |
|---------|-------|---------|---|-------|-------|-------|
|         |       |         | Data Rate [Mbps]                        |       |       |       |
|         | [MHz] |         | 1                                       | 2     | 5.5   | 11    |
| 802.11b | 2412  | 1*      | 14.67                                   | 14.61 | 14.72 | 14.64 |
| 802.11b | 2437  | 6*      | 14.00                                   | 14.01 | 14.01 | 13.93 |
| 802.11b | 2462  | 11*     | 15.13                                   | 15.10 | 15.17 | 15.10 |

**Table 8-2**  
**IEEE 802.11g Average RF Power**

| Mode    | Freq  | Channel | 802.11g (2.4 GHz) Conducted Power [dBm] |       |       |       |       |       |       |       |
|---------|-------|---------|---|-------|-------|-------|-------|-------|-------|-------|
|         |       |         | Data Rate [Mbps]                        |       |       |       |       |       |       |       |
|         | [MHz] |         | 6                                       | 9     | 12    | 18    | 24    | 36    | 48    | 54    |
| 802.11g | 2412  | 1       | 12.32                                   | 12.36 | 12.43 | 12.41 | 12.31 | 12.34 | 12.49 | 12.45 |
| 802.11g | 2437  | 6       | 11.83                                   | 11.84 | 11.84 | 11.88 | 11.79 | 11.79 | 11.98 | 11.92 |
| 802.11g | 2462  | 11      | 12.88                                   | 12.93 | 12.99 | 12.94 | 12.95 | 12.92 | 13.07 | 13.01 |

**Table 8-3**  
**IEEE 802.11n Average RF Power**

| Mode    | Freq  | Channel | 802.11n (2.4 GHz) Conducted Power [dBm] |       |       |       |       |       |       |       |
|---------|-------|---------|---|-------|-------|-------|-------|-------|-------|-------|
|         |       |         | Data Rate [Mbps]                        |       |       |       |       |       |       |       |
|         | [MHz] |         | 6.5                                     | 13    | 20    | 26    | 39    | 52    | 58    | 65    |
| 802.11n | 2412  | 1       | 10.41                                   | 10.47 | 10.43 | 10.44 | 10.41 | 10.44 | 10.53 | 10.42 |
| 802.11n | 2437  | 6       | 9.94                                    | 9.95  | 10.01 | 10.05 | 9.97  | 9.92  | 10.07 | 9.90  |
| 802.11n | 2462  | 11      | 10.63                                   | 10.66 | 10.65 | 10.70 | 10.64 | 10.64 | 10.68 | 10.59 |



|                                   |   |                              |   |  |
|-----------------------------------|---|------------------------------|---|--|
| FCC ID: A3LSMT331                 |  | <b>SAR EVALUATION REPORT</b> |  | <b>Reviewed by:</b><br>Quality Manager |
| Document S/N:<br>0Y1312302508.A3L | Test Dates:<br>01/06/2014-01/24/2014  | DUT Type:<br>Portable Tablet |   | Page 20 of 47                          |

**Table 8-4**  
**IEEE 802.11a Average RF Power**

| Mode    | Freq [MHz] | Channel | 802.11a Conducted Power [dBm] |       |       |       |       |       |       |       |
|---------|------------|---------|-------------------------------|-------|-------|-------|-------|-------|-------|-------|
|         |            |         | Data Rate [Mbps]              |       |       |       |       |       |       |       |
|         |            |         | 6                             | 9     | 12    | 18    | 24    | 36    | 48    | 54    |
| 802.11a | 5180       | 36*     | 9.20                          | 9.22  | 9.19  | 9.41  | 9.27  | 9.39  | 9.44  | 9.42  |
| 802.11a | 5200       | 40      | 9.23                          | 9.30  | 9.26  | 9.48  | 9.31  | 9.42  | 9.46  | 9.43  |
| 802.11a | 5220       | 44      | 9.89                          | 9.91  | 9.92  | 10.08 | 9.90  | 10.06 | 10.09 | 10.08 |
| 802.11a | 5240       | 48*     | 9.27                          | 9.31  | 9.28  | 9.47  | 9.34  | 9.47  | 9.47  | 9.45  |
| 802.11a | 5260       | 52*     | 9.96                          | 9.79  | 10.03 | 10.03 | 9.94  | 9.81  | 10.03 | 9.79  |
| 802.11a | 5280       | 56      | 10.21                         | 10.05 | 10.27 | 10.38 | 10.16 | 10.02 | 10.23 | 10.03 |
| 802.11a | 5300       | 60      | 10.48                         | 10.31 | 10.40 | 10.45 | 10.44 | 10.29 | 10.48 | 10.30 |
| 802.11a | 5320       | 64*     | 9.46                          | 9.31  | 9.55  | 9.52  | 9.44  | 9.31  | 9.48  | 9.29  |
| 802.11a | 5500       | 100     | 8.85                          | 9.03  | 9.08  | 9.09  | 9.08  | 9.04  | 9.03  | 8.87  |
| 802.11a | 5520       | 104*    | 9.36                          | 9.50  | 9.62  | 9.69  | 9.59  | 9.64  | 9.55  | 9.34  |
| 802.11a | 5540       | 108     | 9.57                          | 9.77  | 9.83  | 9.86  | 9.80  | 9.76  | 9.74  | 9.65  |
| 802.11a | 5560       | 112     | 8.84                          | 9.00  | 9.11  | 9.17  | 9.03  | 9.00  | 9.07  | 8.86  |
| 802.11a | 5580       | 116*    | 10.12                         | 9.84  | 9.95  | 9.76  | 10.22 | 10.04 | 10.15 | 10.05 |
| 802.11a | 5600       | 120     | N/A                           | N/A   | N/A   | N/A   | N/A   | N/A   | N/A   | N/A   |
| 802.11a | 5620       | 124     | N/A                           | N/A   | N/A   | N/A   | N/A   | N/A   | N/A   | N/A   |
| 802.11a | 5640       | 128     | N/A                           | N/A   | N/A   | N/A   | N/A   | N/A   | N/A   | N/A   |
| 802.11a | 5660       | 132     | 9.81                          | 9.97  | 10.06 | 10.12 | 10.12 | 9.98  | 9.99  | 9.84  |
| 802.11a | 5680       | 136*    | 9.72                          | 9.91  | 9.95  | 10.02 | 9.95  | 9.87  | 9.88  | 9.77  |
| 802.11a | 5700       | 140     | 10.12                         | 10.26 | 10.23 | 10.23 | 10.25 | 10.33 | 10.29 | 10.10 |
| 802.11a | 5745       | 149*    | 8.88                          | 8.89  | 8.91  | 8.84  | 8.92  | 8.97  | 8.96  | 8.88  |
| 802.11a | 5765       | 153     | 9.43                          | 9.44  | 9.47  | 9.39  | 9.40  | 9.47  | 9.54  | 9.49  |
| 802.11a | 5785       | 157*    | 9.42                          | 9.43  | 9.45  | 9.40  | 9.48  | 9.47  | 9.48  | 9.50  |
| 802.11a | 5805       | 161     | 9.45                          | 9.42  | 9.48  | 9.34  | 9.42  | 9.51  | 9.51  | 9.52  |
| 802.11a | 5825       | 165*    | 10.33                         | 10.36 | 10.40 | 10.23 | 10.40 | 10.35 | 10.47 | 10.37 |

Per FCC KDB Publication 443999 and RSS-210 A9.2(3), transmission on channels which overlap the 5600-5650 MHz is prohibited as a client. This device does not transmit any beacons or initiate any transmissions in 5.3 and 5.5 GHz Band.

(\*) – indicates default channels per KDB Publication 248227 D01v01r02. When the adjacent channels are higher in power than the default channels, these “required channels” are considered for SAR testing instead of the default channels.

|                                   |   |                              |   |                                 |
|-----------------------------------|---|------------------------------|---|---------------------------------|
| FCC ID: A3LSMT331                 |  | <b>SAR EVALUATION REPORT</b> |  | Reviewed by:<br>Quality Manager |
| Document S/N:<br>0Y1312302508.A3L | Test Dates:<br>01/06/2014-01/24/2014  | DUT Type:<br>Portable Tablet |   | Page 21 of 47                   |

**Table 8-5**  
**IEEE 802.11n Average RF Power – 20 MHz Bandwidth**

| Mode    | Freq<br>[MHz] | Channel | 20MHz BW 802.11n (5GHz) Conducted Power [dBm] |       |       |       |       |       |       |       |
|---------|---------------|---------|---|-------|-------|-------|-------|-------|-------|-------|
|         |               |         | Data Rate [Mbps]                              |       |       |       |       |       |       |       |
|         |               |         | 6.5   | 13    | 19.5  | 26    | 39    | 52    | 58.5  | 65    |
| 802.11n | 5180          | 36      | 9.44  | 9.53  | 9.31  | 9.42  | 9.48  | 9.44  | 9.46  | 9.41  |
| 802.11n | 5200          | 40      | 9.51  | 9.62  | 9.31  | 9.48  | 9.51  | 9.49  | 9.44  | 9.42  |
| 802.11n | 5220          | 44      | 9.94  | 10.07 | 9.79  | 9.90  | 10.01 | 9.89  | 10.03 | 9.92  |
| 802.11n | 5240          | 48      | 9.51  | 9.62  | 9.36  | 9.56  | 9.54  | 9.51  | 9.53  | 9.52  |
| 802.11n | 5260          | 52      | 9.92  | 10.04 | 10.00 | 9.97  | 9.98  | 10.03 | 9.95  | 9.92  |
| 802.11n | 5280          | 56      | 10.31   | 10.39 | 10.39 | 10.33 | 10.37 | 10.48 | 10.38 | 10.37 |
| 802.11n | 5300          | 60      | 10.35   | 10.48 | 10.47 | 10.34 | 10.34 | 10.47 | 10.44 | 10.34 |
| 802.11n | 5320          | 64      | 9.60  | 9.78  | 9.67  | 9.63  | 9.61  | 9.69  | 9.66  | 9.69  |
| 802.11n | 5500          | 100     | 8.84  | 9.07  | 9.22  | 9.08  | 9.16  | 9.02  | 9.25  | 9.15  |
| 802.11n | 5520          | 104     | 9.49  | 9.70  | 9.92  | 9.73  | 9.78  | 9.70  | 9.94  | 9.86  |
| 802.11n | 5540          | 108     | 9.55  | 9.75  | 9.92  | 9.84  | 9.98  | 9.76  | 10.02 | 9.86  |
| 802.11n | 5560          | 112     | 9.13  | 9.37  | 9.58  | 9.35  | 9.46  | 9.34  | 9.57  | 9.51  |
| 802.11n | 5580          | 116     | 8.97  | 9.24  | 9.40  | 9.16  | 9.23  | 9.12  | 9.45  | 9.25  |
| 802.11n | 5600          | 120     | N/A   | N/A   | N/A   | N/A   | N/A   | N/A   | N/A   | N/A   |
| 802.11n | 5620          | 124     | N/A   | N/A   | N/A   | N/A   | N/A   | N/A   | N/A   | N/A   |
| 802.11n | 5640          | 128     | N/A   | N/A   | N/A   | N/A   | N/A   | N/A   | N/A   | N/A   |
| 802.11n | 5660          | 132     | 9.85  | 10.04 | 10.27 | 10.16 | 10.18 | 10.07 | 10.27 | 10.21 |
| 802.11n | 5680          | 136     | 9.76  | 10.08 | 10.18 | 9.96  | 10.10 | 9.95  | 10.20 | 10.09 |
| 802.11n | 5700          | 140     | 10.12   | 10.24 | 10.27 | 10.26 | 10.25 | 10.19 | 10.23 | 10.20 |
| 802.11n | 5745          | 149     | 8.99  | 9.06  | 9.05  | 8.95  | 9.02  | 9.02  | 9.14  | 9.11  |
| 802.11n | 5765          | 153     | 9.54  | 9.59  | 9.56  | 9.43  | 9.54  | 9.55  | 9.66  | 9.74  |
| 802.11n | 5785          | 157     | 9.37  | 9.43  | 9.41  | 9.31  | 9.39  | 9.42  | 9.47  | 9.49  |
| 802.11n | 5805          | 161     | 9.43  | 9.47  | 9.46  | 9.43  | 9.52  | 9.43  | 9.56  | 9.61  |
| 802.11n | 5825          | 165     | 10.34   | 10.47 | 10.39 | 10.36 | 10.37 | 10.37 | 10.49 | 10.42 |

**Table 8-6**  
**IEEE 802.11n Average RF Power – 40 MHz Bandwidth**

| Mode    | Freq<br>[MHz] | Channel | 40MHz BW 802.11n (5GHz) Conducted Power [dBm] |      |      |      |      |      |       |      |
|---------|---------------|---------|---|------|------|------|------|------|-------|------|
|         |               |         | Data Rate [Mbps]                              |      |      |      |      |      |       |      |
|         |               |         | 13.5  | 27   | 40.5 | 54   | 81   | 108  | 121.5 | 135  |
| 802.11n | 5190          | 38      | 7.48  | 7.45 | 7.41 | 7.43 | 7.42 | 7.46 | 7.48  | 7.44 |
| 802.11n | 5230          | 46      | 7.27  | 7.37 | 7.42 | 7.39 | 7.39 | 7.34 | 7.37  | 7.41 |
| 802.11n | 5270          | 54      | 7.06  | 7.10 | 7.06 | 6.99 | 7.17 | 7.21 | 7.14  | 7.02 |
| 802.11n | 5310          | 62      | 7.18  | 7.20 | 7.20 | 7.15 | 7.27 | 7.29 | 7.26  | 7.16 |
| 802.11n | 5510          | 102     | 7.32  | 7.41 | 7.43 | 7.33 | 7.41 | 7.38 | 7.38  | 7.47 |
| 802.11n | 5550          | 110     | 7.45  | 7.40 | 7.45 | 7.44 | 7.46 | 7.43 | 7.47  | 7.40 |
| 802.11n | 5590          | 118     | N/A   | N/A  | N/A  | N/A  | N/A  | N/A  | N/A   | N/A  |
| 802.11n | 5630          | 126     | N/A   | N/A  | N/A  | N/A  | N/A  | N/A  | N/A   | N/A  |
| 802.11n | 5670          | 134     | 7.43  | 7.45 | 7.42 | 7.47 | 7.46 | 7.42 | 7.43  | 7.41 |
| 802.11n | 5755          | 151     | 7.49  | 7.38 | 7.36 | 7.48 | 7.36 | 7.42 | 7.47  | 7.33 |
| 802.11n | 5795          | 159     | 7.04  | 7.20 | 7.19 | 7.13 | 7.18 | 7.25 | 7.17  | 7.08 |

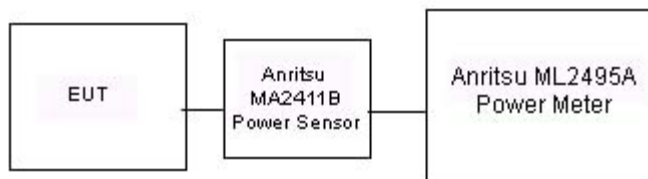
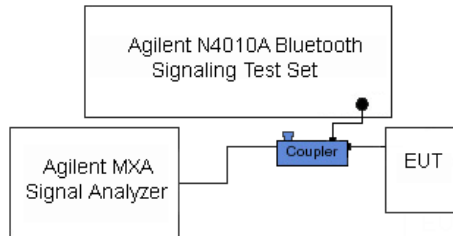

**Figure 8-3**  
**Power Measurement Setup for Bandwidths < 50 MHz**

|                                   |                                      |                              |  |                                 |
|-----------------------------------|--------------------------------------|------------------------------|--|---------------------------------|
| FCC ID: A3LSMT331                 |                                      | <b>SAR EVALUATION REPORT</b> |  | Reviewed by:<br>Quality Manager |
| Document S/N:<br>0Y1312302508.A3L | Test Dates:<br>01/06/2014-01/24/2014 | DUT Type:<br>Portable Tablet |  | Page 22 of 47                   |

**Table 8-7  
Bluetooth Average RF Power**



| Frequency [MHz] | Data Rate [Mbps] | Channel No. | Avg Conducted Power |        |
|-----------------|------------------|-------------|---------------------|--------|
|                 |                  |             | [dBm]               | [mW]   |
| 2402            | 1.0              | 0           | 9.86                | 9.673  |
| 2441            | 1.0              | 39          | 10.14               | 10.317 |
| 2480            | 1.0              | 78          | <b>10.18</b>        | 10.422 |
| 2402            | 2.0              | 0           | 8.14                | 6.515  |
| 2441            | 2.0              | 39          | 8.40                | 6.911  |
| 2480            | 2.0              | 78          | 8.13                | 6.505  |
| 2402            | 3.0              | 0           | 7.84                | 6.084  |
| 2441            | 3.0              | 39          | 8.10                | 6.453  |
| 2480            | 3.0              | 78          | 8.72                | 7.440  |



**Figure 8-4  
Bluetooth Power Measurement Setup**

Justification for reduced test configurations for WIFI channels per KDB Publication 248227 D01v01r02 and October 2012/April 2013 FCC/TCB Meeting Notes:

- For 2.4 GHz, highest average RF output power channel for the lowest data rate for IEEE 802.11b were selected for SAR evaluation. Other IEEE 802.11 modes (including 802.11g/n) were not investigated since the average output powers over all channels and data rates were not more than 0.25 dB higher than the tested channel in the lowest data rate of IEEE 802.11b mode.
- For 5 GHz, highest average RF output power channel for the lowest data rate for IEEE 802.11a were selected for SAR evaluation. Other IEEE 802.11 modes (including 802.11n 20 MHz and 40 MHz) were not investigated since the average output powers over all channels and data rates were not more than 0.25 dB higher than the tested channel in the lowest data rate of IEEE 802.11a mode.
- When the maximum extrapolated peak SAR of the zoom scan for the maximum output channel is <1.6 W/kg and the reported 1g averaged SAR is <0.8 W/kg, SAR testing on other channels is not required. Otherwise, the other default (or corresponding required) test channels were additionally tested using the lowest data rate.
- The bolded data rate and channel above were tested for SAR.

|                                   |   |                              |   |                                 |
|-----------------------------------|---|------------------------------|---|---------------------------------|
| FCC ID: A3LSMT331                 |  | SAR EVALUATION REPORT        |  | Reviewed by:<br>Quality Manager |
| Document S/N:<br>0Y1312302508.A3L | Test Dates:<br>01/06/2014-01/24/2014  | DUT Type:<br>Portable Tablet |   | Page 23 of 47                   |



# 9 SYSTEM VERIFICATION

## 9.1 Tissue Verification

**Table 9-1  
Measured Tissue Properties**

| Calibrated for Tests Performed on: | Tissue Type | Tissue Temp During Calibration (C°) | Measured Frequency (MHz) | Measured Conductivity, $\sigma$ (S/m) | Measured Dielectric Constant, $\epsilon$ | TARGET Conductivity, $\sigma$ (S/m) | TARGET Dielectric Constant, $\epsilon$ | % dev $\sigma$ | % dev $\epsilon$ |
|------------------------------------|-------------|-------------------------------------|--------------------------|---------------------------------------|--|-------------------------------------|--|----------------|------------------|
| 1/6/2014                           | 835H        | 22.0                                | 820                      | 0.902                                 | 41.164                                   | 0.899                               | 41.578                                 | 0.33%          | -1.00%           |
|                                    |             |                                     | 835                      | 0.916                                 | 40.979                                   | 0.900                               | 41.500                                 | 1.78%          | -1.26%           |
|                                    |             |                                     | 850                      | 0.930                                 | 40.798                                   | 0.916                               | 41.500                                 | 1.53%          | -1.69%           |
| 1/8/2014                           | 835H        | 21.2                                | 820                      | 0.906                                 | 41.963                                   | 0.899                               | 41.578                                 | 0.78%          | 0.93%            |
|                                    |             |                                     | 835                      | 0.920                                 | 41.792                                   | 0.900                               | 41.500                                 | 2.22%          | 0.70%            |
|                                    |             |                                     | 850                      | 0.936                                 | 41.610                                   | 0.916                               | 41.500                                 | 2.18%          | 0.27%            |
| 1/8/2014                           | 1900H       | 21.1                                | 1850                     | 1.383                                 | 39.343                                   | 1.400                               | 40.000                                 | -1.21%         | -1.64%           |
|                                    |             |                                     | 1880                     | 1.417                                 | 39.234                                   | 1.400                               | 40.000                                 | 1.21%          | -1.92%           |
|                                    |             |                                     | 1910                     | 1.448                                 | 39.107                                   | 1.400                               | 40.000                                 | 3.43%          | -2.23%           |
| 1/6/2014                           | 2450H       | 21.5                                | 2401                     | 1.820                                 | 39.320                                   | 1.756                               | 39.287                                 | 3.64%          | 0.08%            |
|                                    |             |                                     | 2450                     | 1.877                                 | 39.133                                   | 1.800                               | 39.200                                 | 4.28%          | -0.17%           |
|                                    |             |                                     | 2499                     | 1.934                                 | 38.920                                   | 1.853                               | 39.138                                 | 4.37%          | -0.56%           |
| 1/10/2014                          | 5200H-5800H | 23.4                                | 5200                     | 4.494                                 | 36.716                                   | 4.655                               | 35.986                                 | -3.46%         | 2.03%            |
|                                    |             |                                     | 5220                     | 4.521                                 | 36.658                                   | 4.676                               | 35.963                                 | -3.31%         | 1.93%            |
|                                    |             |                                     | 5300                     | 4.591                                 | 36.609                                   | 4.758                               | 35.871                                 | -3.51%         | 2.06%            |
|                                    |             |                                     | 5580                     | 4.867                                 | 36.212                                   | 5.045                               | 35.551                                 | -3.53%         | 1.86%            |
|                                    |             |                                     | 5600                     | 4.909                                 | 36.184                                   | 5.065                               | 35.529                                 | -3.08%         | 1.84%            |
|                                    |             |                                     | 5800                     | 5.110                                 | 35.984                                   | 5.270                               | 35.300                                 | -3.04%         | 1.94%            |
|                                    |             |                                     | 5825                     | 5.135                                 | 35.915                                   | 5.296                               | 35.271                                 | -3.04%         | 1.83%            |
| 1/8/2014                           | 835B        | 21.2                                | 820                      | 0.989                                 | 54.182                                   | 0.969                               | 55.258                                 | 2.06%          | -1.95%           |
|                                    |             |                                     | 835                      | 1.003                                 | 54.041                                   | 0.970                               | 55.200                                 | 3.40%          | -2.10%           |
|                                    |             |                                     | 850                      | 1.018                                 | 53.917                                   | 0.988                               | 55.154                                 | 3.04%          | -2.24%           |
| 1/16/2014                          | 835B        | 22.3                                | 820                      | 0.986                                 | 53.648                                   | 0.969                               | 55.258                                 | 1.75%          | -2.91%           |
|                                    |             |                                     | 835                      | 0.999                                 | 53.539                                   | 0.970                               | 55.200                                 | 2.99%          | -3.01%           |
|                                    |             |                                     | 850                      | 1.015                                 | 53.347                                   | 0.988                               | 55.154                                 | 2.73%          | -3.28%           |
| 1/13/2014                          | 1900B       | 20.8                                | 1850                     | 1.522                                 | 51.448                                   | 1.520                               | 53.300                                 | 0.13%          | -3.47%           |
|                                    |             |                                     | 1880                     | 1.557                                 | 51.363                                   | 1.520                               | 53.300                                 | 2.43%          | -3.63%           |
|                                    |             |                                     | 1910                     | 1.589                                 | 51.259                                   | 1.520                               | 53.300                                 | 4.54%          | -3.83%           |
| 1/16/2014                          | 1900B       | 22.5                                | 1850                     | 1.521                                 | 51.299                                   | 1.520                               | 53.300                                 | 0.07%          | -3.75%           |
|                                    |             |                                     | 1880                     | 1.557                                 | 51.245                                   | 1.520                               | 53.300                                 | 2.43%          | -3.86%           |
|                                    |             |                                     | 1910                     | 1.583                                 | 51.110                                   | 1.520                               | 53.300                                 | 4.14%          | -4.11%           |
| 1/17/2014                          | 2450B       | 22.5                                | 2401                     | 1.980                                 | 50.967                                   | 1.903                               | 52.765                                 | 4.05%          | -3.41%           |
|                                    |             |                                     | 2450                     | 2.041                                 | 50.745                                   | 1.950                               | 52.700                                 | 4.67%          | -3.71%           |
|                                    |             |                                     | 2499                     | 2.118                                 | 50.578                                   | 2.019                               | 52.638                                 | 4.90%          | -3.91%           |
| 1/24/2014                          | 2450B       | 23.8                                | 2401                     | 1.866                                 | 50.279                                   | 1.903                               | 52.765                                 | -1.94%         | -4.71%           |
|                                    |             |                                     | 2450                     | 1.944                                 | 50.337                                   | 1.950                               | 52.700                                 | -0.31%         | -4.48%           |
|                                    |             |                                     | 2499                     | 1.988                                 | 50.013                                   | 2.019                               | 52.638                                 | -1.54%         | -4.99%           |
| 1/23/2014                          | 5200B-5800B | 22.3                                | 5200                     | 5.318                                 | 47.709                                   | 5.299                               | 49.014                                 | 0.36%          | -2.66%           |
|                                    |             |                                     | 5220                     | 5.360                                 | 47.649                                   | 5.323                               | 48.987                                 | 0.70%          | -2.73%           |
|                                    |             |                                     | 5280                     | 5.453                                 | 47.540                                   | 5.393                               | 48.906                                 | 1.11%          | -2.79%           |
|                                    |             |                                     | 5300                     | 5.470                                 | 47.466                                   | 5.416                               | 48.879                                 | 1.00%          | -2.89%           |
|                                    |             |                                     | 5500                     | 5.792                                 | 46.979                                   | 5.650                               | 48.607                                 | 2.51%          | -3.35%           |
|                                    |             |                                     | 5540                     | 5.841                                 | 46.888                                   | 5.696                               | 48.553                                 | 2.55%          | -3.43%           |
|                                    |             |                                     | 5580                     | 5.889                                 | 46.772                                   | 5.743                               | 48.499                                 | 2.54%          | -3.56%           |
|                                    |             |                                     | 5600                     | 5.932                                 | 46.707                                   | 5.766                               | 48.471                                 | 2.88%          | -3.64%           |
|                                    |             |                                     | 5700                     | 6.086                                 | 46.472                                   | 5.883                               | 48.336                                 | 3.45%          | -3.86%           |
|                                    |             |                                     | 5765                     | 6.202                                 | 46.361                                   | 5.959                               | 48.248                                 | 4.08%          | -3.91%           |
|                                    |             |                                     | 5785                     | 6.218                                 | 46.328                                   | 5.982                               | 48.220                                 | 3.95%          | -3.92%           |
|                                    |             |                                     | 5800                     | 6.236                                 | 46.236                                   | 6.000                               | 48.200                                 | 3.93%          | -4.07%           |
|                                    |             |                                     | 5805                     | 6.253                                 | 46.219                                   | 6.006                               | 48.193                                 | 4.11%          | -4.10%           |
|                                    |             |                                     | 5825                     | 6.279                                 | 46.139                                   | 6.029                               | 48.166                                 | 4.15%          | -4.21%           |

The above measured tissue parameters were used in the DASY software. The DASY software was used to perform interpolation to determine the dielectric parameters at the SAR test device frequencies (per KDB 865664 and IEEE 1528-2013 6.6.1.2). The tissue parameters listed in the SAR test plots may slightly differ from the table above due to significant digit rounding in the software.

|                                   |   |                              |   |                                 |
|-----------------------------------|---|------------------------------|---|---------------------------------|
| FCC ID: A3LSMT331                 |  <b>PCTEST</b><br>ENGINEERING LABORATORY, INC. | <b>SAR EVALUATION REPORT</b> |  | Reviewed by:<br>Quality Manager |
| Document S/N:<br>0Y1312302508.A3L | Test Dates:<br>01/06/2014-01/24/2014  | DUT Type:<br>Portable Tablet |   | Page 24 of 47                   |

## 9.2 Test System Verification

Prior to SAR assessment, the system is verified to  $\pm 10\%$  of the SAR measurement on the reference dipole at the time of calibration by the calibration facility. Full system validation status and result summary can be found in Appendix E.

**Table 9-2**  
**System Verification Results**

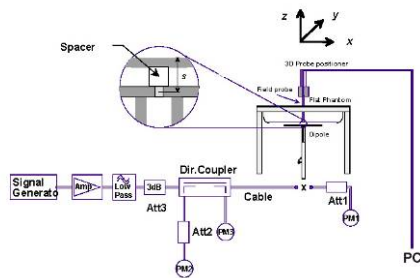

| System Verification<br>TARGET & MEASURED |                        |             |            |                |                  |                 |           |          |                                   |                                     |   |                             |
|--|------------------------|-------------|------------|----------------|------------------|-----------------|-----------|----------|-----------------------------------|-------------------------------------|---|-----------------------------|
| SAR System #                             | Tissue Frequency (MHz) | Tissue Type | Date:      | Amb. Temp (°C) | Liquid Temp (°C) | Input Power (W) | Dipole SN | Probe SN | Measured SAR <sub>1g</sub> (W/kg) | 1 W Target SAR <sub>1g</sub> (W/kg) | 1 W Normalized SAR <sub>1g</sub> (W/kg) | Deviation <sub>1g</sub> (%) |
| D  | 835                    | HEAD        | 01/06/2014 | 22.4           | 22.2             | 0.100           | 4d119     | 3022     | 0.945                             | 9.680                               | 9.450                                   | -2.38%                      |
| D  | 835                    | HEAD        | 01/08/2014 | 23.8           | 21.2             | 0.100           | 4d119     | 3022     | 0.971                             | 9.680                               | 9.710                                   | 0.31%                       |
| G  | 1900                   | HEAD        | 01/08/2014 | 23.9           | 21.1             | 0.100           | 5d148     | 3209     | 4.000                             | 39.700                              | 40.000                                  | 0.76%                       |
| C  | 2450                   | HEAD        | 01/06/2014 | 19.8           | 20.4             | 0.100           | 882       | 3263     | 5.200                             | 51.700                              | 52.000                                  | 0.58%                       |
| E  | 5200                   | HEAD        | 01/10/2014 | 24.1           | 23.3             | 0.040           | 1120      | 3914     | 3.000                             | 76.000                              | 75.000                                  | -1.32%                      |
| E  | 5300                   | HEAD        | 01/10/2014 | 24.1           | 23.1             | 0.040           | 1120      | 3914     | 3.120                             | 78.700                              | 78.000                                  | -0.89%                      |
| E  | 5600                   | HEAD        | 01/10/2014 | 24.1           | 23.1             | 0.040           | 1120      | 3914     | 3.270                             | 79.900                              | 81.750                                  | 2.32%                       |
| E  | 5800                   | HEAD        | 01/10/2014 | 24.0           | 23.3             | 0.040           | 1120      | 3914     | 3.020                             | 74.900                              | 75.500                                  | 0.80%                       |
| K  | 835                    | BODY        | 01/08/2014 | 24.2           | 21.5             | 0.100           | 4d119     | 3333     | 0.939                             | 9.540                               | 9.390                                   | -1.57%                      |
| D  | 835                    | BODY        | 01/16/2014 | 24.3           | 22.3             | 0.100           | 4d119     | 3022     | 0.973                             | 9.540                               | 9.730                                   | 1.99%                       |
| I  | 1900                   | BODY        | 01/13/2014 | 23.6           | 20.8             | 0.100           | 5d149     | 3319     | 3.850                             | 40.500                              | 38.500                                  | -4.94%                      |
| K  | 1900                   | BODY        | 01/16/2014 | 23.8           | 22.5             | 0.100           | 5d148     | 3333     | 3.980                             | 40.800                              | 39.800                                  | -2.45%                      |
| G  | 2450                   | BODY        | 01/17/2014 | 21.9           | 22.9             | 0.100           | 719       | 3209     | 5.310                             | 51.700                              | 53.100                                  | 2.71%                       |
| K  | 2450                   | BODY        | 01/24/2014 | 23.5           | 23.2             | 0.100           | 719       | 3333     | 5.520                             | 51.700                              | 55.200                                  | 6.77%                       |
| E  | 5200                   | BODY        | 01/23/2014 | 24.1           | 22.3             | 0.100           | 1120      | 3914     | 7.820                             | 76.600                              | 78.200                                  | 2.09%                       |
| E  | 5300                   | BODY        | 01/23/2014 | 23.8           | 22.2             | 0.100           | 1120      | 3914     | 7.790                             | 76.800                              | 77.900                                  | 1.43%                       |
| E  | 5500                   | BODY        | 01/23/2014 | 24.1           | 22.3             | 0.100           | 1120      | 3914     | 8.110                             | 79.800                              | 81.100                                  | 1.63%                       |
| E  | 5600                   | BODY        | 01/23/2014 | 24.3           | 22.3             | 0.100           | 1120      | 3914     | 8.300                             | 80.700                              | 83.000                                  | 2.85%                       |
| E  | 5800                   | BODY        | 01/23/2014 | 24.4           | 22.3             | 0.100           | 1120      | 3914     | 7.180                             | 75.500                              | 71.800                                  | -4.90%                      |



**Figure 9-1**  
**System Verification Setup Diagram**



**Figure 9-2**  
**System Verification Setup Photo**

|                                   |   |                              |   |                                 |
|-----------------------------------|---|------------------------------|---|---------------------------------|
| FCC ID: A3LSMT331                 |  | SAR EVALUATION REPORT        |  | Reviewed by:<br>Quality Manager |
| Document S/N:<br>0Y1312302508.A3L | Test Dates:<br>01/06/2014-01/24/2014  | DUT Type:<br>Portable Tablet |   | Page 25 of 47                   |

# 10 SAR DATA SUMMARY

## 10.1 Standalone Head SAR Data

**Table 10-1  
GSM 850 Head SAR**



| MEASUREMENT RESULTS   |     |           |         |                             |                       |                  |   |               |                      |            |          |                |                 |        |
|---|-----|-----------|---------|-----------------------------|-----------------------|------------------|---|---------------|----------------------|------------|----------|----------------|-----------------|--------|
| FREQUENCY   |     | Mode/Band | Service | Maximum Allowed Power [dBm] | Conducted Power [dBm] | Power Drift [dB] | Side  | Test Position | Device Serial Number | Duty Cycle | SAR (1g) | Scaling Factor | Scaled SAR (1g) | Plot # |
| MHz   | Ch. |           |         |                             |                       |                  |   |               |                      |            | (W/kg)   |                | (W/kg)          |        |
| 824.20  | 128 | GSM850    | GSM     | 30.5                        | 29.54                 | -0.02            | Right   | Cheek         | 30-12-02             | 1:8.3      | 0.785    | 1.247          | 0.979           | A1     |
| 836.60  | 190 | GSM850    | GSM     | 30.5                        | 29.44                 | -0.06            | Right   | Cheek         | 30-12-02             | 1:8.3      | 0.717    | 1.276          | 0.915           |        |
| 848.80  | 251 | GSM850    | GSM     | 30.5                        | 29.56                 | -0.03            | Right   | Cheek         | 30-12-02             | 1:8.3      | 0.633    | 1.242          | 0.786           |        |
| 836.60  | 190 | GSM850    | GSM     | 30.5                        | 29.44                 | -0.04            | Right   | Tilt          | 30-12-02             | 1:8.3      | 0.519    | 1.276          | 0.662           |        |
| 836.60  | 190 | GSM850    | GSM     | 30.5                        | 29.44                 | -0.13            | Left  | Cheek         | 30-12-02             | 1:8.3      | 0.595    | 1.276          | 0.759           |        |
| 836.60  | 190 | GSM850    | GSM     | 30.5                        | 29.44                 | -0.01            | Left  | Tilt          | 30-12-02             | 1:8.3      | 0.408    | 1.276          | 0.521           |        |
| ANSI / IEEE C95.1 1992 - SAFETY LIMIT<br>Spatial Peak<br>Uncontrolled Exposure/General Population |     |           |         |                             |                       |                  | Head<br>1.6 W/kg (mW/g)<br>averaged over 1 gram |               |                      |            |          |                |                 |        |

**Table 10-2  
GSM 1900 Head SAR**

| MEASUREMENT RESULTS   |     |           |         |                             |                       |                  |   |               |                      |            |          |                |                 |        |
|---|-----|-----------|---------|-----------------------------|-----------------------|------------------|---|---------------|----------------------|------------|----------|----------------|-----------------|--------|
| FREQUENCY   |     | Mode/Band | Service | Maximum Allowed Power [dBm] | Conducted Power [dBm] | Power Drift [dB] | Side  | Test Position | Device Serial Number | Duty Cycle | SAR (1g) | Scaling Factor | Scaled SAR (1g) | Plot # |
| MHz   | Ch. |           |         |                             |                       |                  |   |               |                      |            | (W/kg)   |                | (W/kg)          |        |
| 1880.00   | 661 | GSM1900   | GSM     | 23.5                        | 22.71                 | 0.16             | Right   | Cheek         | 30-12-02             | 1:8.3      | 0.418    | 1.199          | 0.501           | A2     |
| 1880.00   | 661 | GSM1900   | GSM     | 23.5                        | 22.71                 | 0.20             | Right   | Tilt          | 30-12-02             | 1:8.3      | 0.399    | 1.199          | 0.478           |        |
| 1880.00   | 661 | GSM1900   | GSM     | 23.5                        | 22.71                 | 0.04             | Left  | Cheek         | 30-12-02             | 1:8.3      | 0.146    | 1.199          | 0.175           |        |
| 1880.00   | 661 | GSM1900   | GSM     | 23.5                        | 22.71                 | -0.06            | Left  | Tilt          | 30-12-02             | 1:8.3      | 0.145    | 1.199          | 0.174           |        |
| ANSI / IEEE C95.1 1992 - SAFETY LIMIT<br>Spatial Peak<br>Uncontrolled Exposure/General Population |     |           |         |                             |                       |                  | Head<br>1.6 W/kg (mW/g)<br>averaged over 1 gram |               |                      |            |          |                |                 |        |

**Table 10-3  
UMTS 850 Head SAR**

| MEASUREMENT RESULTS   |      |           |         |                             |                       |                  |   |               |                      |            |          |                |                 |        |
|---|------|-----------|---------|-----------------------------|-----------------------|------------------|---|---------------|----------------------|------------|----------|----------------|-----------------|--------|
| FREQUENCY   |      | Mode/Band | Service | Maximum Allowed Power [dBm] | Conducted Power [dBm] | Power Drift [dB] | Side  | Test Position | Device Serial Number | Duty Cycle | SAR (1g) | Scaling Factor | Scaled SAR (1g) | Plot # |
| MHz   | Ch.  |           |         |                             |                       |                  |   |               |                      |            | (W/kg)   |                | (W/kg)          |        |
| 826.40  | 4132 | UMTS 850  | RMC     | 22.0                        | 21.18                 | 0.07             | Right   | Cheek         | 30-12-02             | 1:1        | 0.883    | 1.208          | 1.067           | A3     |
| 836.60  | 4183 | UMTS 850  | RMC     | 22.0                        | 21.08                 | -0.08            | Right   | Cheek         | 30-12-02             | 1:1        | 0.839    | 1.236          | 1.037           |        |
| 846.60  | 4233 | UMTS 850  | RMC     | 22.0                        | 21.16                 | -0.14            | Right   | Cheek         | 30-12-02             | 1:1        | 0.877    | 1.213          | 1.064           |        |
| 836.60  | 4183 | UMTS 850  | RMC     | 22.0                        | 21.08                 | -0.03            | Right   | Tilt          | 30-12-02             | 1:1        | 0.630    | 1.236          | 0.779           |        |
| 826.40  | 4132 | UMTS 850  | RMC     | 22.0                        | 21.18                 | 0.10             | Left  | Cheek         | 30-12-02             | 1:1        | 0.528    | 1.208          | 0.638           |        |
| 836.60  | 4183 | UMTS 850  | RMC     | 22.0                        | 21.08                 | 0.05             | Left  | Cheek         | 30-12-02             | 1:1        | 0.658    | 1.236          | 0.813           |        |
| 846.60  | 4233 | UMTS 850  | RMC     | 22.0                        | 21.16                 | 0.09             | Left  | Cheek         | 30-12-02             | 1:1        | 0.602    | 1.213          | 0.730           |        |
| 836.60  | 4183 | UMTS 850  | RMC     | 22.0                        | 21.08                 | -0.03            | Left  | Tilt          | 30-12-02             | 1:1        | 0.450    | 1.236          | 0.556           |        |
| ANSI / IEEE C95.1 1992 - SAFETY LIMIT<br>Spatial Peak<br>Uncontrolled Exposure/General Population |      |           |         |                             |                       |                  | Head<br>1.6 W/kg (mW/g)<br>averaged over 1 gram |               |                      |            |          |                |                 |        |

|                                   |   |                              |   |                                 |
|-----------------------------------|---|------------------------------|---|---------------------------------|
| FCC ID: A3LSMT331                 |  | <b>SAR EVALUATION REPORT</b> |  | Reviewed by:<br>Quality Manager |
| Document S/N:<br>0Y1312302508.A3L | Test Dates:<br>01/06/2014-01/24/2014  | DUT Type:<br>Portable Tablet |   | Page 26 of 47                   |

**Table 10-4  
UMTS 1900 Head SAR**



| MEASUREMENT RESULTS   |      |           |         |                             |                       |                  |   |               |                      |            |          |                |                 |        |
|---|------|-----------|---------|-----------------------------|-----------------------|------------------|---|---------------|----------------------|------------|----------|----------------|-----------------|--------|
| FREQUENCY   |      | Mode/Band | Service | Maximum Allowed Power [dBm] | Conducted Power [dBm] | Power Drift [dB] | Side  | Test Position | Device Serial Number | Duty Cycle | SAR (1g) | Scaling Factor | Scaled SAR (1g) | Plot # |
| MHz   | Ch.  |           |         |                             |                       |                  |   |               |                      |            | (W/kg)   |                | (W/kg)          |        |
| 1880.00   | 9400 | UMTS 1900 | RMC     | 14.5                        | 13.41                 | 0.12             | Right   | Cheek         | 30-12-02             | 1:1        | 0.399    | 1.285          | 0.513           | A4     |
| 1880.00   | 9400 | UMTS 1900 | RMC     | 14.5                        | 13.41                 | 0.15             | Right   | Tilt          | 30-12-02             | 1:1        | 0.349    | 1.285          | 0.448           |        |
| 1880.00   | 9400 | UMTS 1900 | RMC     | 14.5                        | 13.41                 | 0.03             | Left  | Cheek         | 30-12-02             | 1:1        | 0.150    | 1.285          | 0.193           |        |
| 1880.00   | 9400 | UMTS 1900 | RMC     | 14.5                        | 13.41                 | 0.05             | Left  | Tilt          | 30-12-02             | 1:1        | 0.146    | 1.285          | 0.188           |        |
| ANSI / IEEE C95.1 1992 - SAFETY LIMIT<br>Spatial Peak<br>Uncontrolled Exposure/General Population |      |           |         |                             |                       |                  | Head<br>1.6 W/kg (mW/g)<br>averaged over 1 gram |               |                      |            |          |                |                 |        |

**Table 10-5  
DTS Head SAR**

| MEASUREMENT RESULTS   |     |              |         |                             |                       |                  |   |               |                      |                  |            |          |                |                 |        |
|---|-----|--------------|---------|-----------------------------|-----------------------|------------------|---|---------------|----------------------|------------------|------------|----------|----------------|-----------------|--------|
| FREQUENCY   |     | Mode         | Service | Maximum Allowed Power [dBm] | Conducted Power [dBm] | Power Drift [dB] | Side  | Test Position | Device Serial Number | Data Rate (Mbps) | Duty Cycle | SAR (1g) | Scaling Factor | Scaled SAR (1g) | Plot # |
| MHz   | Ch. |              |         |                             |                       |                  |   |               |                      |                  |            | (W/kg)   |                | (W/kg)          |        |
| 2462  | 11  | IEEE 802.11b | DSSS    | 15.5                        | 15.13                 | 0.03             | Right   | Cheek         | 000323/8             | 1                | 1:1        | 0.042    | 1.089          | 0.046           |        |
| 2462  | 11  | IEEE 802.11b | DSSS    | 15.5                        | 15.13                 | -0.01            | Right   | Tilt          | 000323/8             | 1                | 1:1        | 0.026    | 1.089          | 0.028           |        |
| 2462  | 11  | IEEE 802.11b | DSSS    | 15.5                        | 15.13                 | 0.05             | Left  | Cheek         | 000323/8             | 1                | 1:1        | 0.029    | 1.089          | 0.032           |        |
| 2462  | 11  | IEEE 802.11b | DSSS    | 15.5                        | 15.13                 | 0.03             | Left  | Tilt          | 000323/8             | 1                | 1:1        | 0.043    | 1.089          | 0.047           | A5     |
| 5825  | 165 | IEEE 802.11a | OFDM    | 10.5                        | 10.33                 | 0.00             | Right   | Cheek         | 000323/8             | 6                | 1:1        | 0.000    | 1.040          | 0.000           |        |
| 5825  | 165 | IEEE 802.11a | OFDM    | 10.5                        | 10.33                 | 0.00             | Right   | Tilt          | 000323/8             | 6                | 1:1        | 0.000    | 1.040          | 0.000           |        |
| 5825  | 165 | IEEE 802.11a | OFDM    | 10.5                        | 10.33                 | 0.05             | Left  | Cheek         | 000323/8             | 6                | 1:1        | 0.011    | 1.040          | 0.011           |        |
| 5825  | 165 | IEEE 802.11a | OFDM    | 10.5                        | 10.33                 | 0.04             | Left  | Tilt          | 000323/8             | 6                | 1:1        | 0.013    | 1.040          | 0.014           | A6     |
| ANSI / IEEE C95.1 1992 - SAFETY LIMIT<br>Spatial Peak<br>Uncontrolled Exposure/General Population |     |              |         |                             |                       |                  | Head<br>1.6 W/kg (mW/g)<br>averaged over 1 gram |               |                      |                  |            |          |                |                 |        |

**Table 10-6  
NII Head SAR**

| MEASUREMENT RESULTS   |     |              |         |                             |                       |                  |   |               |                      |                  |            |          |                |                 |        |
|---|-----|--------------|---------|-----------------------------|-----------------------|------------------|---|---------------|----------------------|------------------|------------|----------|----------------|-----------------|--------|
| FREQUENCY   |     | Mode         | Service | Maximum Allowed Power [dBm] | Conducted Power [dBm] | Power Drift [dB] | Side  | Test Position | Device Serial Number | Data Rate (Mbps) | Duty Cycle | SAR (1g) | Scaling Factor | Scaled SAR (1g) | Plot # |
| MHz   | Ch. |              |         |                             |                       |                  |   |               |                      |                  |            | (W/kg)   |                | (W/kg)          |        |
| 5220  | 44  | IEEE 802.11a | OFDM    | 10.5                        | 9.89                  | 0.00             | Right   | Cheek         | 000323/8             | 6                | 1:1        | 0.000    | 1.151          | 0.000           |        |
| 5220  | 44  | IEEE 802.11a | OFDM    | 10.5                        | 9.89                  | 0.00             | Right   | Tilt          | 000323/8             | 6                | 1:1        | 0.000    | 1.151          | 0.000           |        |
| 5220  | 44  | IEEE 802.11a | OFDM    | 10.5                        | 9.89                  | -0.01            | Left  | Cheek         | 000323/8             | 6                | 1:1        | 0.000    | 1.151          | 0.000           |        |
| 5220  | 44  | IEEE 802.11a | OFDM    | 10.5                        | 9.89                  | -0.03            | Left  | Tilt          | 000323/8             | 6                | 1:1        | 0.012    | 1.151          | 0.014           |        |
| 5300  | 60  | IEEE 802.11a | OFDM    | 10.5                        | 10.48                 | 0.00             | Right   | Cheek         | 000323/8             | 6                | 1:1        | 0.000    | 1.005          | 0.000           |        |
| 5300  | 60  | IEEE 802.11a | OFDM    | 10.5                        | 10.48                 | 0.00             | Right   | Tilt          | 000323/8             | 6                | 1:1        | 0.000    | 1.005          | 0.000           |        |
| 5300  | 60  | IEEE 802.11a | OFDM    | 10.5                        | 10.48                 | 0.00             | Left  | Cheek         | 000323/8             | 6                | 1:1        | 0.000    | 1.005          | 0.000           |        |
| 5300  | 60  | IEEE 802.11a | OFDM    | 10.5                        | 10.48                 | -0.02            | Left  | Tilt          | 000323/8             | 6                | 1:1        | 0.012    | 1.005          | 0.012           |        |
| 5580  | 116 | IEEE 802.11a | OFDM    | 10.5                        | 10.12                 | 0.00             | Right   | Cheek         | 000323/8             | 6                | 1:1        | 0.000    | 1.091          | 0.000           |        |
| 5580  | 116 | IEEE 802.11a | OFDM    | 10.5                        | 10.12                 | 0.00             | Right   | Tilt          | 000323/8             | 6                | 1:1        | 0.000    | 1.091          | 0.000           |        |
| 5580  | 116 | IEEE 802.11a | OFDM    | 10.5                        | 10.12                 | 0.03             | Left  | Cheek         | 000323/8             | 6                | 1:1        | 0.011    | 1.091          | 0.012           |        |
| 5580  | 116 | IEEE 802.11a | OFDM    | 10.5                        | 10.12                 | -0.01            | Left  | Tilt          | 000323/8             | 6                | 1:1        | 0.014    | 1.091          | 0.015           | A7     |
| ANSI / IEEE C95.1 1992 - SAFETY LIMIT<br>Spatial Peak<br>Uncontrolled Exposure/General Population |     |              |         |                             |                       |                  | Head<br>1.6 W/kg (mW/g)<br>averaged over 1 gram |               |                      |                  |            |          |                |                 |        |



|                                   |   |                              |   |                                 |
|-----------------------------------|---|------------------------------|---|---------------------------------|
| FCC ID: A3LSMT331                 |  | <b>SAR EVALUATION REPORT</b> |  | Reviewed by:<br>Quality Manager |
| Document S/N:<br>0Y1312302508.A3L | Test Dates:<br>01/06/2014-01/24/2014  | DUT Type:<br>Portable Tablet |   | Page 27 of 47                   |

## 10.2 Standalone Body SAR Data

**Table 10-7  
GSM/UMTS Body SAR Data**

| MEASUREMENT RESULTS   |      |           |         |                             |                       |                  |   |                      |                 |            |      |          |                |                 |        |
|---|------|-----------|---------|-----------------------------|-----------------------|------------------|---|----------------------|-----------------|------------|------|----------|----------------|-----------------|--------|
| FREQUENCY   |      | Mode      | Service | Maximum Allowed Power [dBm] | Conducted Power [dBm] | Power Drift [dB] | Spacing   | Device Serial Number | # of GPRS Slots | Duty Cycle | Side | SAR (1g) | Scaling Factor | Scaled SAR (1g) | Plot # |
| MHz   | Ch.  |           |         |                             |                       |                  |   |                      |                 |            |      | (W/kg)   |                | (W/kg)          |        |
| 836.60  | 190  | GSM 850   | GPRS    | 29.0                        | 28.50                 | -0.01            | 12 mm   | PCT04                | 3               | 1:2.76     | back | 0.506    | 1.122          | 0.568           |        |
| 824.20  | 128  | GSM 850   | GPRS    | 26.0                        | 25.68                 | 0.00             | 0 mm  | PCT03                | 3               | 1:2.76     | back | 0.909    | 1.076          | 0.978           | A8     |
| 836.60  | 190  | GSM 850   | GPRS    | 26.0                        | 25.60                 | -0.03            | 0 mm  | PCT03                | 3               | 1:2.76     | back | 0.826    | 1.096          | 0.905           |        |
| 848.80  | 251  | GSM 850   | GPRS    | 26.0                        | 25.62                 | -0.01            | 0 mm  | PCT03                | 3               | 1:2.76     | back | 0.802    | 1.091          | 0.875           |        |
| 836.60  | 190  | GSM 850   | GPRS    | 29.0                        | 28.50                 | 0.02             | 9 mm  | PCT04                | 3               | 1:2.76     | top  | 0.392    | 1.122          | 0.440           |        |
| 836.60  | 190  | GSM 850   | GPRS    | 26.0                        | 25.60                 | 0.01             | 0 mm  | PCT03                | 3               | 1:2.76     | top  | 0.369    | 1.096          | 0.404           |        |
| 836.60  | 190  | GSM 850   | GPRS    | 29.0                        | 28.50                 | 0.00             | 0 mm  | PCT04                | 3               | 1:2.76     | left | 0.416    | 1.122          | 0.467           |        |
| 824.20  | 128  | GSM 850   | GPRS    | 26.0                        | 25.68                 | 0.00             | 0 mm  | PCT03                | 3               | 1:2.76     | back | 0.839    | 1.076          | 0.903           |        |
| 1880.00   | 661  | GSM 1900  | GPRS    | 26.5                        | 25.55                 | -0.01            | 12 mm   | PCT04                | 3               | 1:2.76     | back | 0.308    | 1.245          | 0.383           |        |
| 1880.00   | 661  | GSM 1900  | GPRS    | 18.0                        | 16.91                 | -0.04            | 0 mm  | PCT03                | 4               | 1:2.076    | back | 0.364    | 1.285          | 0.468           |        |
| 1880.00   | 661  | GSM 1900  | GPRS    | 26.5                        | 25.55                 | -0.04            | 9 mm  | PCT04                | 3               | 1:2.76     | top  | 0.482    | 1.245          | 0.600           | A9     |
| 1880.00   | 661  | GSM 1900  | GPRS    | 18.0                        | 16.91                 | -0.06            | 0 mm  | PCT03                | 4               | 1:2.076    | top  | 0.418    | 1.285          | 0.537           |        |
| 1880.00   | 661  | GSM 1900  | GPRS    | 26.5                        | 25.55                 | -0.08            | 0 mm  | PCT04                | 3               | 1:2.76     | left | 0.320    | 1.245          | 0.398           |        |
| 836.60  | 4183 | UMTS 850  | RMC     | 23.5                        | 22.91                 | -0.02            | 12 mm   | 16-01-01             | N/A             | 1:1        | back | 0.476    | 1.146          | 0.545           | A10    |
| 836.60  | 4183 | UMTS 850  | RMC     | 22.0                        | 21.08                 | -0.01            | 0 mm  | 30-12-02             | N/A             | 1:1        | back | 0.389    | 1.236          | 0.481           |        |
| 836.60  | 4183 | UMTS 850  | RMC     | 23.5                        | 22.91                 | 0.00             | 9 mm  | 16-01-01             | N/A             | 1:1        | top  | 0.437    | 1.146          | 0.501           |        |
| 836.60  | 4183 | UMTS 850  | RMC     | 22.0                        | 21.08                 | -0.02            | 0 mm  | 30-12-02             | N/A             | 1:1        | top  | 0.154    | 1.236          | 0.190           |        |
| 836.60  | 4183 | UMTS 850  | RMC     | 23.5                        | 22.91                 | -0.10            | 0 mm  | 16-01-01             | N/A             | 1:1        | left | 0.255    | 1.146          | 0.292           |        |
| 1880.00   | 9400 | UMTS 1900 | RMC     | 22.0                        | 21.63                 | 0.03             | 12 mm   | 16-01-01             | N/A             | 1:1        | back | 0.674    | 1.089          | 0.734           |        |
| 1880.00   | 9400 | UMTS 1900 | RMC     | 14.5                        | 13.41                 | 0.00             | 0 mm  | 30-12-02             | N/A             | 1:1        | back | 0.356    | 1.285          | 0.457           |        |
| 1852.40   | 9262 | UMTS 1900 | RMC     | 22.0                        | 21.54                 | -0.02            | 9 mm  | 16-01-01             | N/A             | 1:1        | top  | 0.739    | 1.112          | 0.822           |        |
| 1880.00   | 9400 | UMTS 1900 | RMC     | 22.0                        | 21.63                 | -0.05            | 9 mm  | 16-01-01             | N/A             | 1:1        | top  | 0.818    | 1.089          | 0.891           |        |
| 1907.60   | 9538 | UMTS 1900 | RMC     | 22.0                        | 21.50                 | -0.01            | 9 mm  | 16-01-01             | N/A             | 1:1        | top  | 0.808    | 1.122          | 0.907           |        |
| 1880.00   | 9400 | UMTS 1900 | RMC     | 14.5                        | 13.41                 | -0.02            | 0 mm  | 30-12-02             | N/A             | 1:1        | top  | 0.364    | 1.285          | 0.468           |        |
| 1880.00   | 9400 | UMTS 1900 | RMC     | 22.0                        | 21.63                 | 0.06             | 0 mm  | 16-01-01             | N/A             | 1:1        | left | 0.277    | 1.089          | 0.302           |        |
| 1880.00   | 9400 | UMTS 1900 | RMC     | 22.0                        | 21.63                 | -0.02            | 9 mm  | 16-01-01             | N/A             | 1:1        | top  | 0.833    | 1.089          | 0.907           | A11    |
| ANSI / IEEE C95.1 1992 - SAFETY LIMIT<br>Spatial Peak<br>Uncontrolled Exposure/General Population |      |           |         |                             |                       |                  | Body<br>1.6 W/kg (mW/g)<br>averaged over 1 gram |                      |                 |            |      |          |                |                 |        |

**Note: Variability tests are highlighted blue in the above table.**

|                                   |   |                              |   |                                 |
|-----------------------------------|---|------------------------------|---|---------------------------------|
| FCC ID: A3LSMT331                 |  | SAR EVALUATION REPORT        |  | Reviewed by:<br>Quality Manager |
| Document S/N:<br>0Y1312302508.A3L | Test Dates:<br>01/06/2014-01/24/2014  | DUT Type:<br>Portable Tablet | Page 28 of 47   |                                 |



**Table 10-9  
DTS Body SAR**

| MEASUREMENT RESULTS   |     |              |         |                             |                       |                  |   |                      |                  |        |            |          |                |                 |        |
|---|-----|--------------|---------|-----------------------------|-----------------------|------------------|---|----------------------|------------------|--------|------------|----------|----------------|-----------------|--------|
| FREQUENCY   |     | Mode         | Service | Maximum Allowed Power [dBm] | Conducted Power [dBm] | Power Drift [dB] | Spacing   | Device Serial Number | Data Rate (Mbps) | Side   | Duty Cycle | SAR (1g) | Scaling Factor | Scaled SAR (1g) | Plot # |
| MHz   | Ch. |              |         |                             |                       |                  |   |                      |                  |        |            | (W/kg)   |                | (W/kg)          |        |
| 2462  | 11  | IEEE 802.11b | DSSS    | 15.5                        | 15.13                 | 0.19             | 0 mm  | 000410/3             | 1                | back   | 1:1        | 0.266    | 1.089          | 0.290           | A12    |
| 2462  | 11  | IEEE 802.11b | DSSS    | 15.5                        | 15.13                 | 0.11             | 0 mm  | 000410/3             | 1                | bottom | 1:1        | 0.000    | 1.089          | 0.000           |        |
| 2462  | 11  | IEEE 802.11b | DSSS    | 15.5                        | 15.13                 | 0.05             | 0 mm  | 000410/3             | 1                | right  | 1:1        | 0.000    | 1.089          | 0.000           |        |
| 5765  | 153 | IEEE 802.11a | OFDM    | 10.5                        | 9.43                  | 0.07             | 0 mm  | 000815/3             | 6                | back   | 1:1        | 0.486    | 1.279          | 0.622           | A13    |
| 5805  | 161 | IEEE 802.11a | OFDM    | 10.5                        | 9.45                  | 0.10             | 0 mm  | 000815/3             | 6                | back   | 1:1        | 0.449    | 1.274          | 0.572           |        |
| 5825  | 165 | IEEE 802.11a | OFDM    | 10.5                        | 10.33                 | 0.05             | 0 mm  | 000815/3             | 6                | back   | 1:1        | 0.396    | 1.040          | 0.412           |        |
| 5825  | 165 | IEEE 802.11a | OFDM    | 10.5                        | 10.33                 | -0.19            | 0 mm  | 000815/3             | 6                | bottom | 1:1        | 0.156    | 1.040          | 0.162           |        |
| 5825  | 165 | IEEE 802.11a | OFDM    | 10.5                        | 10.33                 | -0.05            | 0 mm  | 000815/3             | 6                | right  | 1:1        | 0.015    | 1.040          | 0.016           |        |
| ANSI / IEEE C95.1 1992 - SAFETY LIMIT<br>Spatial Peak<br>Uncontrolled Exposure/General Population |     |              |         |                             |                       |                  | Body<br>1.6 W/kg (mW/g)<br>averaged over 1 gram |                      |                  |        |            |          |                |                 |        |

**Table 10-10  
NII Body SAR**

| MEASUREMENT RESULTS   |     |              |         |                             |                       |                  |   |                      |                  |        |            |          |                |                 |        |
|---|-----|--------------|---------|-----------------------------|-----------------------|------------------|---|----------------------|------------------|--------|------------|----------|----------------|-----------------|--------|
| FREQUENCY   |     | Mode         | Service | Maximum Allowed Power [dBm] | Conducted Power [dBm] | Power Drift [dB] | Spacing   | Device Serial Number | Data Rate (Mbps) | Side   | Duty Cycle | SAR (1g) | Scaling Factor | Scaled SAR (1g) | Plot # |
| MHz   | Ch. |              |         |                             |                       |                  |   |                      |                  |        |            | (W/kg)   |                | (W/kg)          |        |
| 5200  | 40  | IEEE 802.11a | OFDM    | 10.5                        | 9.23                  | 0.04             | 0 mm  | 000815/3             | 6                | back   | 1:1        | 0.793    | 1.340          | 1.063           |        |
| 5220  | 44  | IEEE 802.11a | OFDM    | 10.5                        | 9.89                  | 0.05             | 0 mm  | 000815/3             | 6                | back   | 1:1        | 0.838    | 1.151          | 0.965           |        |
| 5220  | 44  | IEEE 802.11a | OFDM    | 10.5                        | 9.89                  | -0.07            | 0 mm  | 000815/3             | 6                | bottom | 1:1        | 0.264    | 1.151          | 0.304           |        |
| 5220  | 44  | IEEE 802.11a | OFDM    | 10.5                        | 9.89                  | 0.02             | 0 mm  | 000815/3             | 6                | right  | 1:1        | 0.038    | 1.151          | 0.044           |        |
| 5220  | 44  | IEEE 802.11a | OFDM    | 10.5                        | 9.89                  | 0.04             | 0 mm  | 000815/3             | 6                | back   | 1:1        | 0.928    | 1.151          | 1.068           |        |
| 5280  | 56  | IEEE 802.11a | OFDM    | 10.5                        | 10.21                 | 0.06             | 0 mm  | 000815/3             | 6                | back   | 1:1        | 0.920    | 1.069          | 0.983           |        |
| 5300  | 60  | IEEE 802.11a | OFDM    | 10.5                        | 10.48                 | 0.04             | 0 mm  | 000815/3             | 6                | back   | 1:1        | 0.945    | 1.005          | 0.950           |        |
| 5300  | 60  | IEEE 802.11a | OFDM    | 10.5                        | 10.48                 | -0.09            | 0 mm  | 000815/3             | 6                | bottom | 1:1        | 0.307    | 1.005          | 0.309           |        |
| 5300  | 60  | IEEE 802.11a | OFDM    | 10.5                        | 10.48                 | -0.12            | 0 mm  | 000815/3             | 6                | right  | 1:1        | 0.039    | 1.005          | 0.039           |        |
| 5300  | 60  | IEEE 802.11a | OFDM    | 10.5                        | 10.48                 | -0.01            | 0 mm  | 000815/3             | 6                | back   | 1:1        | 0.948    | 1.005          | 0.953           | A14    |
| 5540  | 108 | IEEE 802.11a | OFDM    | 10.5                        | 9.57                  | 0.06             | 0 mm  | 000815/3             | 6                | back   | 1:1        | 0.831    | 1.239          | 1.030           |        |
| 5580  | 116 | IEEE 802.11a | OFDM    | 10.5                        | 10.12                 | 0.07             | 0 mm  | 000815/3             | 6                | back   | 1:1        | 0.863    | 1.091          | 0.942           |        |
| 5700  | 140 | IEEE 802.11a | OFDM    | 10.5                        | 10.12                 | 0.03             | 0 mm  | 000815/3             | 6                | back   | 1:1        | 0.645    | 1.091          | 0.704           |        |
| 5580  | 116 | IEEE 802.11a | OFDM    | 10.5                        | 10.12                 | 0.03             | 0 mm  | 000815/3             | 6                | bottom | 1:1        | 0.240    | 1.091          | 0.262           |        |
| 5580  | 116 | IEEE 802.11a | OFDM    | 10.5                        | 10.12                 | 0.05             | 0 mm  | 000815/3             | 6                | right  | 1:1        | 0.022    | 1.091          | 0.024           |        |
| 5540  | 108 | IEEE 802.11a | OFDM    | 10.5                        | 9.57                  | 0.00             | 0 mm  | 000815/3             | 6                | back   | 1:1        | 0.837    | 1.239          | 1.037           |        |
| 5580  | 116 | IEEE 802.11a | OFDM    | 10.5                        | 10.12                 | 0.00             | 0 mm  | 000815/3             | 6                | back   | 1:1        | 0.860    | 1.091          | 0.938           |        |
| ANSI / IEEE C95.1 1992 - SAFETY LIMIT<br>Spatial Peak<br>Uncontrolled Exposure/General Population |     |              |         |                             |                       |                  | Body<br>1.6 W/kg (mW/g)<br>averaged over 1 gram |                      |                  |        |            |          |                |                 |        |

**Note: Variability tests are highlighted blue in the above table.**

|                                   |   |                              |   |                                 |
|-----------------------------------|---|------------------------------|---|---------------------------------|
| FCC ID: A3LSMT331                 |  | <b>SAR EVALUATION REPORT</b> |  | Reviewed by:<br>Quality Manager |
| Document S/N:<br>0Y1312302508.A3L | Test Dates:<br>01/06/2014-01/24/2014  | DUT Type:<br>Portable Tablet | Page 29 of 47   |                                 |



**Table 10-11  
DSS Body SAR**

| MEASUREMENT RESULTS   |     |           |         |                             |                       |                  |   |                      |                  |        |            |          |                |                 |        |
|---|-----|-----------|---------|-----------------------------|-----------------------|------------------|---|----------------------|------------------|--------|------------|----------|----------------|-----------------|--------|
| FREQUENCY   |     | Mode      | Service | Maximum Allowed Power [dBm] | Conducted Power [dBm] | Power Drift [dB] | Spacing   | Device Serial Number | Data Rate (Mbps) | Side   | Duty Cycle | SAR (1g) | Scaling Factor | Scaled SAR (1g) | Plot # |
| MHz   | Ch. |           |         |                             |                       |                  |   |                      |                  |        |            | (W/kg)   |                | (W/kg)          |        |
| 2480  | 78  | Bluetooth | FHSS    | 10.5                        | 10.18                 | 0.16             | 0 mm  | 000815/3             | 1                | back   | 1:1        | 0.124    | 1.076          | 0.133           | A15    |
| 2480  | 78  | Bluetooth | FHSS    | 10.5                        | 10.18                 | 0.03             | 0 mm  | 000815/3             | 1                | bottom | 1:1        | 0.021    | 1.076          | 0.023           |        |
| 2480  | 78  | Bluetooth | FHSS    | 10.5                        | 10.18                 | 0.03             | 0 mm  | 000815/3             | 1                | right  | 1:1        | 0.016    | 1.076          | 0.017           |        |
| ANSI / IEEE C95.1 1992 - SAFETY LIMIT<br>Spatial Peak<br>Uncontrolled Exposure/General Population |     |           |         |                             |                       |                  | Body<br>1.6 W/kg (mW/g)<br>averaged over 1 gram |                      |                  |        |            |          |                |                 |        |

## 10.2 SAR Test Notes

### General Notes:

1. The test data reported are the worst-case SAR values according to test procedures specified in IEEE 1528-2003, FCC KDB 616217 D04, and FCC KDB Publication 447498 D01v05.
2. Batteries are fully charged at the beginning of the SAR measurements.
3. Liquid tissue depth was at least 15.0 cm for all frequencies.
4. The manufacturer has confirmed that the device(s) tested have the same physical, mechanical and thermal characteristics and are within operational tolerances expected for production units.
5. SAR results were scaled to the maximum allowed power to demonstrate compliance per FCC KDB Publication 447498 D01v05.
6. Per FCC KDB 865664 D01v01, variability SAR test was performed when the measured SAR result for a frequency band were greater than 0.8 W/kg. Repeat SAR measurement is highlighted blue in the table above for clarity. Please see Section 12 for variability analysis.
7. Per FCC KDB 616217 D04 Section 4.3, SAR tests are required for the back surface and edges of the tablet with the tablet touching the phantom. The SAR Exclusion Threshold in FCC KDB 447498 D01v05 was applied to determine SAR test exclusion for adjacent edge configurations. SAR tests were required for top and left edge for the main antenna and bottom and right edge for the BT/WLAN antenna.
8. Head SAR testing was required for this tablet because it has a speaker/receiver and microphone positioning that allows for a held-to-ear configuration usage. All head SAR tests were performed at reduced power levels for GSM/UMTS.

|                                   |   |                              |   |                                 |
|-----------------------------------|---|------------------------------|---|---------------------------------|
| FCC ID: A3LSMT331                 |  | <b>SAR EVALUATION REPORT</b> |  | Reviewed by:<br>Quality Manager |
| Document S/N:<br>0Y1312302508.A3L | Test Dates:<br>01/06/2014-01/24/2014  | DUT Type:<br>Portable Tablet | Page 30 of 47   |                                 |

**GSM Test Notes:**



1. Justification for reduced test configurations per KDB Publication 941225 D03v01 and October 2013 TCB Workshop Notes: The source-based frame-averaged output power was evaluated for all GPRS/EDGE slot configurations. The configuration with the highest target frame averaged output power was evaluated for SAR. When the maximum frame-averaged powers are equivalent across two or more slots (within 0.25 dB), the configuration with the most number of time slots was tested.
2. Per FCC KDB Publication 447498 D01v05, if the reported (scaled) SAR measured at the middle channel or highest output power channel for each test configuration is  $\leq 0.8$  W/kg then testing at the other channels is not required for such test configuration(s). When the maximum output power variation across the required test channels is  $> \frac{1}{2}$  dB, instead of the middle channel, the highest output power channel was used.

**UMTS Notes:**

1. UMTS mode in was tested under RMC 12.2 kbps with HSPA Inactive per KDB Publication 941225 D01v02. HSPA SAR was not required since the average output power of the HSPA subtests was not more than 0.25 dB higher than the RMC level and SAR was less than 1.2 W/kg.
2. Per FCC KDB Publication 447498 D01v05, if the reported (scaled) SAR measured at the middle channel or highest output power channel for each test configuration is  $\leq 0.8$  W/kg then testing at the other channels is not required for such test configuration(s). When the maximum output power variation across the required test channels is  $> \frac{1}{2}$  dB, instead of the middle channel, the highest output power channel was used.

**WLAN/ BT Notes:**

1. Justification for reduced test configurations for WIFI channels per KDB Publication 248227 D01v01r02 and October 2012 FCC/TCB Meeting Notes for 2.4 GHz WIFI: Highest average RF output power channel for the lowest data rate was selected for SAR evaluation in 802.11b. Other IEEE 802.11 modes (including 802.11g/n) were not investigated since the average output powers over all channels and data rates were not more than 0.25 dB higher than the tested channel in the lowest data rate of IEEE 802.11b mode.
2. Justification for reduced test configurations for WIFI channels per KDB Publication 248227 D01v01r02 and October 2012 FCC/TCB Meeting Notes for 5 GHz WIFI: Highest average RF output power channel for the lowest data rate was selected for SAR evaluation in 802.11a. Other IEEE 802.11 modes (including 802.11n 20 MHz and 40 MHz bandwidths) were not investigated since the average output powers over all channels and data rates were not more than 0.25 dB higher than the tested channel in the lowest data rate of IEEE 802.11a mode.
3. There is no sensor power reduction mechanism applied for WIFI/BT modes.
4. WIFI transmission was verified using an uncalibrated spectrum analyzer.
5. Since the maximum extrapolated peak SAR of the zoom scan for the maximum output channel is  $>1.6$  W/kg and the reported 1g averaged SAR is  $>0.8$  W/kg, SAR testing on other default channels was required.

|  |   |                                     |   |  |
|--|---|-------------------------------------|---|--|
| <b>FCC ID:</b> A3LSMT331                 |  | <b>SAR EVALUATION REPORT</b>        |  | <b>Reviewed by:</b><br>Quality Manager |
| <b>Document S/N:</b><br>0Y1312302508.A3L | <b>Test Dates:</b><br>01/06/2014-01/24/2014   | <b>DUT Type:</b><br>Portable Tablet | Page 31 of 47   |  |

# 11 FCC MULTI-TX AND ANTENNA SAR CONSIDERATIONS

## 11.1 Introduction

The following procedures adopted from FCC KDB Publication 447498 D01v05 are applicable to handsets with built-in unlicensed transmitters such as 802.11a/b/g/n and Bluetooth devices which may simultaneously transmit with the licensed transmitter.

## 11.2 Simultaneous Transmission Procedures

This device contains transmitters that may operate simultaneously. Therefore simultaneous transmission analysis is required. Per FCC KDB 447498 D01v05 IV.C.1.iii and IEEE 1528-2013 Section 6.3.4.1.2, simultaneous transmission SAR test exclusion may be applied when the sum of the 1-g SAR for all the simultaneous transmitting antennas in a specific physical test configuration is  $\leq 1.6$  W/kg. When standalone SAR is not required to be measured, per FCC KDB 447498 D01v05 4.3.2 2), the following equation must be used to estimate the standalone 1g SAR for simultaneous transmission assessment involving that transmitter.



$$\text{Estimated SAR} = \frac{\sqrt{f(\text{GHz})}}{7.5} * \frac{(\text{Max Power of channel, mW})}{\text{Min. Separation Distance, mm}}$$

**Table 11-1  
Estimated SAR**

| Mode         | Configuration                    | Frequency | Maximum Allowed Power | Separation Distance (Body) | Estimated SAR (Body) |
|--------------|----------------------------------|-----------|-----------------------|----------------------------|----------------------|
|              |                                  | [MHz]     | [dBm]                 | [mm]                       | [W/kg]               |
| Bluetooth LE | Bottom and Right Edges Touching* | 2440      | 3.50                  | 5                          | <b>0.083</b>         |

**Notes:**

1. Held-to ear configurations are not applicable to Bluetooth operations and therefore were not considered for simultaneous transmission.
2. Per KDB Publication 447498 D01v05, the maximum power of the channel was rounded to the nearest mW before calculation.
3. When the test separation distance was > 50 mm, an estimated SAR of 0.4 W/kg was used to determine simultaneous transmission SAR exclusion, for configurations excluded per FCC KDB Publication 447498 D01v05. When the test separation distance was < 50 mm, an estimated SAR was determined per FCC KDB Publication 447498 D01v05.
4. (\*) – Per FCC KDB 447498, when the test separation distance is < 5 mm, a distance of 5 mm is applied to determine estimated SAR.

|  |   |                                     |   |  |
|--|---|-------------------------------------|---|--|
| FCC ID: A3LSMT331                        |  <b>PCTEST</b><br>ENGINEERING LABORATORY, INC. | <b>SAR EVALUATION REPORT</b>        |  | <b>Reviewed by:</b><br>Quality Manager |
| <b>Document S/N:</b><br>0Y1312302508.A3L | <b>Test Dates:</b><br>01/06/2014-01/24/2014   | <b>DUT Type:</b><br>Portable Tablet | Page 32 of 47   |  |



## 11.3 Head SAR Simultaneous Transmission Analysis

**Table 11-2**  
**Simultaneous Transmission Scenario with 2.4 GHz WLAN (Held to Ear)**

| Simult Tx | Configuration | GSM 850 SAR (W/kg)  | 2.4 GHz WLAN SAR (W/kg) | Σ SAR (W/kg) | Simult Tx | Configuration | GSM 1900 SAR (W/kg)  | 2.4 GHz WLAN SAR (W/kg) | Σ SAR (W/kg) |
|-----------|---------------|---------------------|-------------------------|--------------|-----------|---------------|----------------------|-------------------------|--------------|
| Head SAR  | Right Cheek   | 0.979               | 0.046                   | <b>1.025</b> | Head SAR  | Right Cheek   | 0.501                | 0.046                   | <b>0.547</b> |
|           | Right Tilt    | 0.662               | 0.028                   | 0.690        |           | Right Tilt    | 0.478                | 0.028                   | 0.506        |
|           | Left Cheek    | 0.759               | 0.032                   | 0.791        |           | Left Cheek    | 0.175                | 0.032                   | 0.207        |
|           | Left Tilt     | 0.521               | 0.047                   | 0.568        |           | Left Tilt     | 0.174                | 0.047                   | 0.221        |
| Simult Tx | Configuration | UMTS 850 SAR (W/kg) | 2.4 GHz WLAN SAR (W/kg) | Σ SAR (W/kg) | Simult Tx | Configuration | UMTS 1900 SAR (W/kg) | 2.4 GHz WLAN SAR (W/kg) | Σ SAR (W/kg) |
| Head SAR  | Right Cheek   | 1.067               | 0.046                   | <b>1.113</b> | Head SAR  | Right Cheek   | 0.513                | 0.046                   | <b>0.559</b> |
|           | Right Tilt    | 0.779               | 0.028                   | 0.807        |           | Right Tilt    | 0.448                | 0.028                   | 0.476        |
|           | Left Cheek    | 0.813               | 0.032                   | 0.845        |           | Left Cheek    | 0.193                | 0.032                   | 0.225        |
|           | Left Tilt     | 0.556               | 0.047                   | 0.603        |           | Left Tilt     | 0.188                | 0.047                   | 0.235        |

**Table 11-3**  
**Simultaneous Transmission Scenario with 5 GHz WLAN (Held to Ear)**

| Simult Tx | Configuration | GSM 850 SAR (W/kg)  | 5 GHz WLAN SAR (W/kg) | Σ SAR (W/kg) | Simult Tx | Configuration | GSM 1900 SAR (W/kg)  | 5 GHz WLAN SAR (W/kg) | Σ SAR (W/kg) |
|-----------|---------------|---------------------|-----------------------|--------------|-----------|---------------|----------------------|-----------------------|--------------|
| Head SAR  | Right Cheek   | 0.979               | 0.000                 | <b>0.979</b> | Head SAR  | Right Cheek   | 0.501                | 0.000                 | <b>0.501</b> |
|           | Right Tilt    | 0.662               | 0.000                 | 0.662        |           | Right Tilt    | 0.478                | 0.000                 | 0.478        |
|           | Left Cheek    | 0.759               | 0.012                 | 0.771        |           | Left Cheek    | 0.175                | 0.012                 | 0.187        |
|           | Left Tilt     | 0.521               | 0.015                 | 0.536        |           | Left Tilt     | 0.174                | 0.015                 | 0.189        |
| Simult Tx | Configuration | UMTS 850 SAR (W/kg) | 5 GHz WLAN SAR (W/kg) | Σ SAR (W/kg) | Simult Tx | Configuration | UMTS 1900 SAR (W/kg) | 5 GHz WLAN SAR (W/kg) | Σ SAR (W/kg) |
| Head SAR  | Right Cheek   | 1.067               | 0.000                 | <b>1.067</b> | Head SAR  | Right Cheek   | 0.513                | 0.000                 | <b>0.513</b> |
|           | Right Tilt    | 0.779               | 0.000                 | 0.779        |           | Right Tilt    | 0.448                | 0.000                 | 0.448        |
|           | Left Cheek    | 0.813               | 0.012                 | 0.825        |           | Left Cheek    | 0.193                | 0.012                 | 0.205        |
|           | Left Tilt     | 0.556               | 0.015                 | 0.571        |           | Left Tilt     | 0.188                | 0.015                 | 0.203        |

|                                   |   |                              |   |  |
|-----------------------------------|---|------------------------------|---|--|
| FCC ID: A3LSMT331                 |  | <b>SAR EVALUATION REPORT</b> |  | <b>Reviewed by:</b><br>Quality Manager |
| Document S/N:<br>0Y1312302508.A3L | Test Dates:<br>01/06/2014-01/24/2014  | DUT Type:<br>Portable Tablet |   | Page 33 of 47                          |



## 11.4 Body Simultaneous Transmission Analysis

**Table 11-4**  
**Simultaneous Transmission Scenario with 2.4 GHz WLAN (Body at 0.0 cm)**

| Simult Tx | Configuration | GPRS 850 SAR (W/kg) | 2.4 GHz WLAN SAR (W/kg) | $\Sigma$ SAR (W/kg) | Simult Tx | Configuration | GPRS 1900 SAR (W/kg) | 2.4 GHz WLAN SAR (W/kg) | $\Sigma$ SAR (W/kg) |
|-----------|---------------|---------------------|-------------------------|---------------------|-----------|---------------|----------------------|-------------------------|---------------------|
| Body SAR  | Back          | 0.978               | 0.290                   | <b>1.268</b>        | Body SAR  | Back          | 0.468                | 0.290                   | 0.758               |
|           | Top           | 0.404               | 0.400                   | 0.804               |           | Top           | 0.537                | 0.400                   | <b>0.937</b>        |
|           | Bottom        | 0.400               | 0.000                   | 0.400               |           | Bottom        | 0.400                | 0.000                   | 0.400               |
|           | Right         | 0.400               | 0.000                   | 0.400               |           | Right         | 0.400                | 0.000                   | 0.400               |
|           | Left          | 0.467               | 0.400                   | 0.867               |           | Left          | 0.398                | 0.400                   | 0.798               |
| Simult Tx | Configuration | UMTS 850 SAR (W/kg) | 2.4 GHz WLAN SAR (W/kg) | $\Sigma$ SAR (W/kg) | Simult Tx | Configuration | UMTS 1900 SAR (W/kg) | 2.4 GHz WLAN SAR (W/kg) | $\Sigma$ SAR (W/kg) |
| Body SAR  | Back          | 0.481               | 0.290                   | <b>0.771</b>        | Body SAR  | Back          | 0.457                | 0.290                   | 0.747               |
|           | Top           | 0.190               | 0.400                   | 0.590               |           | Top           | 0.468                | 0.400                   | <b>0.868</b>        |
|           | Bottom        | 0.400               | 0.000                   | 0.400               |           | Bottom        | 0.400                | 0.000                   | 0.400               |
|           | Right         | 0.400               | 0.000                   | 0.400               |           | Right         | 0.400                | 0.000                   | 0.400               |
|           | Left          | 0.292               | 0.400                   | 0.692               |           | Left          | 0.302                | 0.400                   | 0.702               |

**Table 11-5**  
**Simultaneous Transmission Scenario with 5 GHz WLAN (Body at 0.0 cm)**

| Simult Tx | Configuration | GPRS 850 SAR (W/kg) | 5 GHz WLAN SAR (W/kg) | $\Sigma$ SAR (W/kg) | SPLSR     | Simult Tx     | Configuration        | GPRS 1900 SAR (W/kg)  | 5 GHz WLAN SAR (W/kg) | $\Sigma$ SAR (W/kg) |
|-----------|---------------|---------------------|-----------------------|---------------------|-----------|---------------|----------------------|-----------------------|-----------------------|---------------------|
| Body SAR  | Back          | 0.978               | 1.068                 | See note 1          | 0.01      | Body SAR      | Back                 | 0.468                 | 1.068                 | <b>1.536</b>        |
|           | Top           | 0.404               | 0.400                 | 0.804               | N/A       |               | Top                  | 0.537                 | 0.400                 | 0.937               |
|           | Bottom        | 0.400               | 0.309                 | 0.709               | N/A       |               | Bottom               | 0.400                 | 0.309                 | 0.709               |
|           | Right         | 0.400               | 0.044                 | 0.444               | N/A       |               | Right                | 0.400                 | 0.044                 | 0.444               |
|           | Left          | 0.467               | 0.400                 | 0.867               | N/A       |               | Left                 | 0.398                 | 0.400                 | 0.798               |
| Simult Tx | Configuration | UMTS 850 SAR (W/kg) | 5 GHz WLAN SAR (W/kg) | $\Sigma$ SAR (W/kg) | Simult Tx | Configuration | UMTS 1900 SAR (W/kg) | 5 GHz WLAN SAR (W/kg) | $\Sigma$ SAR (W/kg)   |                     |
| Body SAR  | Back          | 0.481               | 1.068                 | <b>1.549</b>        | Body SAR  | Back          | 0.457                | 1.068                 | <b>1.525</b>          |                     |
|           | Top           | 0.190               | 0.400                 | 0.590               |           | Top           | 0.468                | 0.400                 | 0.868                 |                     |
|           | Bottom        | 0.400               | 0.309                 | 0.709               |           | Bottom        | 0.400                | 0.309                 | 0.709                 |                     |
|           | Right         | 0.400               | 0.044                 | 0.444               |           | Right         | 0.400                | 0.044                 | 0.444                 |                     |
|           | Left          | 0.292               | 0.400                 | 0.692               |           | Left          | 0.302                | 0.400                 | 0.702                 |                     |

|                                   |   |                              |   |  |
|-----------------------------------|---|------------------------------|---|--|
| FCC ID: A3LSMT331                 |  | <b>SAR EVALUATION REPORT</b> |  | <b>Reviewed by:</b><br>Quality Manager |
| Document S/N:<br>0Y1312302508.A3L | Test Dates:<br>01/06/2014-01/24/2014  | DUT Type:<br>Portable Tablet |   | Page 34 of 47                          |

**Table 11-6**  
**Simultaneous Transmission Scenario with Bluetooth (Body at 0.0 cm)**

| Simult Tx | Configuration | GPRS 850 SAR (W/kg) | Bluetooth SAR (W/kg) | Σ SAR (W/kg) | Simult Tx | Configuration | GPRS 1900 SAR (W/kg) | Bluetooth SAR (W/kg) | Σ SAR (W/kg) |
|-----------|---------------|---------------------|----------------------|--------------|-----------|---------------|----------------------|----------------------|--------------|
| Body SAR  | Back          | 0.978               | 0.133                | 1.111        | Body SAR  | Back          | 0.468                | 0.133                | 0.601        |
|           | Top           | 0.404               | 0.400                | 0.804        |           | Top           | 0.537                | 0.400                | <b>0.937</b> |
|           | Bottom        | 0.400               | 0.083                | 0.483        |           | Bottom        | 0.400                | 0.083                | 0.483        |
|           | Right         | 0.400               | 0.083                | 0.483        |           | Right         | 0.400                | 0.083                | 0.483        |
|           | Left          | 0.467               | 0.400                | 0.867        |           | Left          | 0.398                | 0.400                | 0.798        |
| Simult Tx | Configuration | UMTS 850 SAR (W/kg) | Bluetooth SAR (W/kg) | Σ SAR (W/kg) | Simult Tx | Configuration | UMTS 1900 SAR (W/kg) | Bluetooth SAR (W/kg) | Σ SAR (W/kg) |
| Body SAR  | Back          | 0.481               | 0.133                | 0.614        | Body SAR  | Back          | 0.457                | 0.133                | 0.590        |
|           | Top           | 0.190               | 0.400                | 0.590        |           | Top           | 0.468                | 0.400                | <b>0.868</b> |
|           | Bottom        | 0.400               | 0.083                | 0.483        |           | Bottom        | 0.400                | 0.083                | 0.483        |
|           | Right         | 0.400               | 0.083                | 0.483        |           | Right         | 0.400                | 0.083                | 0.483        |
|           | Left          | 0.292               | 0.400                | <b>0.692</b> |           | Left          | 0.302                | 0.400                | 0.702        |

Note: Estimated Bluetooth LE SAR was used to evaluate Bottom and Right Edges since these were more conservative than the measured Bluetooth values.

**Table 11-7**  
**Simultaneous Transmission Scenario with 2.4 GHz WLAN (Body at 12 mm)**



| Configuration | Mode      | 2G/3G SAR (W/kg) | 2.4 GHz WLAN SAR (W/kg) | Σ SAR (W/kg) |
|---------------|-----------|------------------|-------------------------|--------------|
| Back Side     | GSM 850   | 0.568            | <0.290                  | <0.858       |
| Back Side     | GSM 1900  | 0.383            | <0.290                  | <0.673       |
| Back Side     | UMTS 850  | 0.545            | <0.290                  | <0.835       |
| Back Side     | UMTS 1900 | 0.734            | <0.290                  | <1.024       |

**Table 11-8**  
**Simultaneous Transmission Scenario with 5 GHz WLAN (Body at 12 mm)**

| Configuration | Mode      | 2G/3G SAR (W/kg) | 5 GHz WLAN SAR (W/kg) | Σ SAR (W/kg) | SPLSR |
|---------------|-----------|------------------|-----------------------|--------------|-------|
| Back Side     | GSM 850   | 0.568            | <1.068                | See Note 1   | <0.01 |
| Back Side     | GSM 1900  | 0.383            | <1.068                | <1.451       | N/A   |
| Back Side     | UMTS 850  | 0.545            | <1.068                | See Note 1   | <0.01 |
| Back Side     | UMTS 1900 | 0.734            | <1.068                | See Note 1   | <0.01 |

**Table 11-9**  
**Simultaneous Transmission Scenario with Bluetooth (Body at 12 mm)**

| Configuration | Mode      | 2G/3G SAR (W/kg) | Bluetooth SAR (W/kg) | Σ SAR (W/kg) |
|---------------|-----------|------------------|----------------------|--------------|
| Back Side     | GSM 850   | 0.568            | <0.133               | <0.701       |
| Back Side     | GSM 1900  | 0.383            | <0.133               | <0.516       |
| Back Side     | UMTS 850  | 0.545            | <0.133               | <0.678       |
| Back Side     | UMTS 1900 | 0.734            | <0.133               | <0.867       |

|                                   |  |   |                                 |
|-----------------------------------|--|---|---------------------------------|
| FCC ID: A3LSMT331                 |  <b>SAR EVALUATION REPORT</b> |  | Reviewed by:<br>Quality Manager |
| Document S/N:<br>0Y1312302508.A3L | Test Dates:<br>01/06/2014-01/24/2014   | DUT Type:<br>Portable Tablet  | Page 35 of 47                   |

**Table 11-10**  
**Simultaneous Transmission Scenario with 2.4 GHz WLAN (Body at 9 mm)**

| Configuration | Mode      | 2G/3G SAR (W/kg) | 2.4 GHz WLAN SAR (W/kg) | Σ SAR (W/kg) |
|---------------|-----------|------------------|-------------------------|--------------|
| Top Edge      | GSM 850   | 0.440            | 0.400                   | 0.840        |
| Top Edge      | GSM 1900  | 0.600            | 0.400                   | 1.000        |
| Top Edge      | UMTS 850  | 0.501            | 0.400                   | 0.901        |
| Top Edge      | UMTS 1900 | 0.907            | 0.400                   | 1.307        |

**Table 11-11**  
**Simultaneous Transmission Scenario with 5 GHz WLAN (Body at 9 mm)**



| Configuration | Mode      | 2G/3G SAR (W/kg) | 5 GHz WLAN SAR (W/kg) | Σ SAR (W/kg) |
|---------------|-----------|------------------|-----------------------|--------------|
| Top Edge      | GSM 850   | 0.440            | 0.400                 | 0.840        |
| Top Edge      | GSM 1900  | 0.600            | 0.400                 | 1.000        |
| Top Edge      | UMTS 850  | 0.501            | 0.400                 | 0.901        |
| Top Edge      | UMTS 1900 | 0.907            | 0.400                 | 1.307        |

**Table 11-12**  
**Simultaneous Transmission Scenario with Bluetooth (Body at 9 mm)**

| Configuration | Mode      | 2G/3G SAR (W/kg) | Bluetooth SAR (W/kg) | Σ SAR (W/kg) |
|---------------|-----------|------------------|----------------------|--------------|
| Top Edge      | GSM 850   | 0.440            | 0.400                | 0.840        |
| Top Edge      | GSM 1900  | 0.600            | 0.400                | 1.000        |
| Top Edge      | UMTS 850  | 0.501            | 0.400                | 0.901        |
| Top Edge      | UMTS 1900 | 0.907            | 0.400                | 1.307        |

**Notes:**

1. No evaluation was performed to determine the aggregate 1g SAR for these configurations as the SPLS ratio between the antenna pairs was not higher than 0.04 per FCC KDB 447498 D01v05. See Section 11.5 for detailed SPLS ratio analysis.
2. When the test separation distance was > 50 mm, an estimated SAR of 0.4 W/kg was used to determine simultaneous transmission SAR exclusion, for configuration excluded per FCC KDB 447498 D01v05.
3. For SAR summations for body 1.2 cm, 2.4 GHz WLAN, 5 GHz WLAN, and Bluetooth SAR values for 0.0 cm were used since the 0.0 cm test distance for 2.4 GHz WLAN, 5 GHz WLAN and Bluetooth were more conservative. "<" denotes that the 0.0 cm 2.4 GHz WLAN, 5 GHz WLAN and Bluetooth SAR values were used for summation purposes.
4. Per FCC KDB 616217 D04 4.3, when the voice mode is limited to speaker mode or headset operations only for body configurations, additional SAR testing for tablet voice use is not required. Therefore voice standalone and simultaneous combinations with Bluetooth are not evaluated for body configurations

|                                   |   |                              |   |                                 |
|-----------------------------------|---|------------------------------|---|---------------------------------|
| FCC ID: A3LSMT331                 |  | <b>SAR EVALUATION REPORT</b> |  | Reviewed by:<br>Quality Manager |
| Document S/N:<br>0Y1312302508.A3L | Test Dates:<br>01/06/2014-01/24/2014  | DUT Type:<br>Portable Tablet |   | Page 36 of 47                   |

## 11.5 SPLSR Evaluation and Analysis

Per FCC KDB Publication 447498 D01v05, when the sum of the standalone transmitters is more than 1.6 W/kg, the SAR sum to peak locations can be analyzed to determine SAR distribution overlaps. When the SAR peak to location ratio (shown below) for each pair of antennas is  $\leq 0.04$ , simultaneous SAR evaluation is not required. The distance between the transmitters was calculated using the following formula.

$$\text{Distance}_{\text{Tx1} - \text{Tx2}} = R_i = \sqrt{(x_1 - x_2)^2 + (y_1 - y_2)^2 + (z_1 - z_2)^2}$$

$$\text{SPLS Ratio} = \frac{(SAR_1 + SAR_2)^{1.5}}{R_i}$$

The sum of the standalone SAR values was above 1.6 W/kg for the Body Back side configuration at a separation distance of 0 mm with GPRS 850 MHz antenna operating at limited output power with 5 GHz WIFI.

**Table 11-13**  
**Peak SAR Locations for Body Back Side at 0 mm GPRS 850 MHz and 5 GHz WLAN**

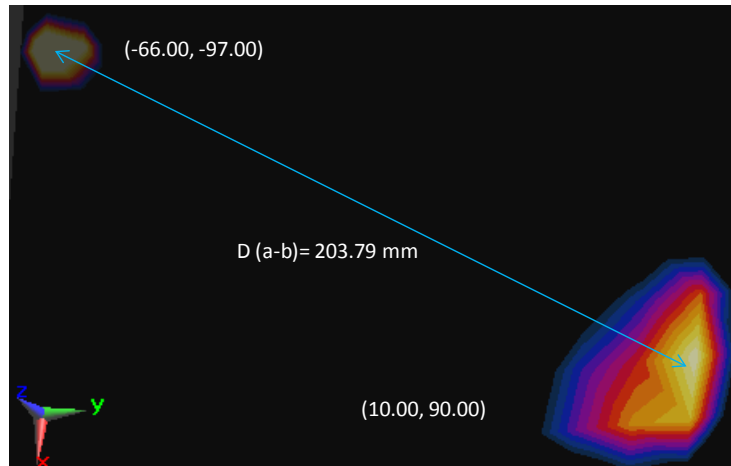

| Mode/Band    | x (mm) | y (mm) |
|--------------|--------|--------|
| 5 GHz WLAN   | -66.00 | -97.00 |
| 850 MHz GPRS | 10.00  | 90.00  |



**Figure 11-1**  
**Peak SAR Locations of 5 GHz WLAN and GPRS 850 MHz**

**Table 11-14**  
**SAR Sum to Peak Location Separation Ratio Calculation**

| Antenna Pair |              | Standalone 1g SAR (W/kg) |       | Standalone SAR Sum (W/kg) | Peak SAR Separation Distance (mm) | SPLS Ratio                             |
|--------------|--------------|--------------------------|-------|---------------------------|-----------------------------------|--|
| Ant "a"      | Ant "b"      | a                        | b     | a+b                       | D <sub>a-b</sub>                  | (a+b) <sup>1.5</sup> /D <sub>a-b</sub> |
| 5 GHz WLAN   | 850 MHz GPRS | 1.068                    | 0.978 | 2.046                     | 203.79                            | 0.01                                   |

|                                   |   |                              |   |                                 |
|-----------------------------------|---|------------------------------|---|---------------------------------|
| FCC ID: A3LSMT331                 |  PCTEST ENGINEERING LABORATORY, INC. | SAR EVALUATION REPORT        |  | Reviewed by:<br>Quality Manager |
| Document S/N:<br>0Y1312302508.A3L | Test Dates:<br>01/06/2014-01/24/2014  | DUT Type:<br>Portable Tablet |   | Page 37 of 47                   |

The sum of the standalone SAR values was above 1.6 W/kg for the Body Back side configuration at a separation distance of 12 mm with GPRS 850 MHz antenna operating at max output power with 5 GHz WIFI.

**Table 11-15**  
**Peak SAR Locations for Body Back Side at 12 mm GPRS 850 MHz and 5 GHz WLAN**

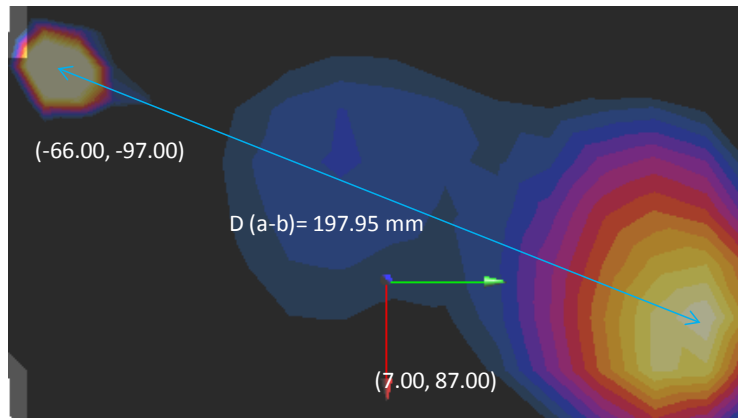

| Mode/Band    | x (mm) | y (mm) |
|--------------|--------|--------|
| 5 GHz WLAN   | -66.00 | -97.00 |
| 850 MHz GPRS | 7.00   | 87.00  |



**Figure 11-2**  
**Peak SAR Locations of 5 GHz WLAN and GPRS 850 MHz**

**Table 11-16**  
**SAR Sum to Peak Location Separation Ratio Calculation**

| Antenna Pair |              | Standalone 1g SAR (W/kg) |       | Standalone SAR Sum (W/kg) | Peak SAR Separation Distance (mm) | SPLS Ratio            |
|--------------|--------------|--------------------------|-------|---------------------------|-----------------------------------|-----------------------|
| Ant "a"      | Ant "b"      | a                        | b     | a+b                       | $D_{a-b}$                         | $(a+b)^{1.5}/D_{a-b}$ |
| 5 GHz WLAN   | 850 MHz GPRS | <1.068                   | 0.568 | < 1.636                   | 197.95                            | < 0.01                |

|                                   |  |                              |   |                                 |
|-----------------------------------|--|------------------------------|---|---------------------------------|
| FCC ID: A3LSMT331                 |  PCTEST<br>ENGINEERING LABORATORY, INC. | SAR EVALUATION REPORT        |  | Reviewed by:<br>Quality Manager |
| Document S/N:<br>0Y1312302508.A3L | Test Dates:<br>01/06/2014-01/24/2014   | DUT Type:<br>Portable Tablet |   | Page 38 of 47                   |

The sum of the standalone SAR values was above 1.6 W/kg for the Body Back side configuration at a separation distance of 12 mm with UMTS 850 MHz antenna operating at max output power with 5 GHz WIFI.

**Table 11-17**  
**Peak SAR Locations for Body Back Side at 12 mm UMTS 850 MHz and 5 GHz WLAN**

| Mode/Band    | x (mm) | y (mm) |
|--------------|--------|--------|
| 5 GHz WLAN   | -66.00 | -97.00 |
| 850 MHz UMTS | 20.50  | 91.00  |

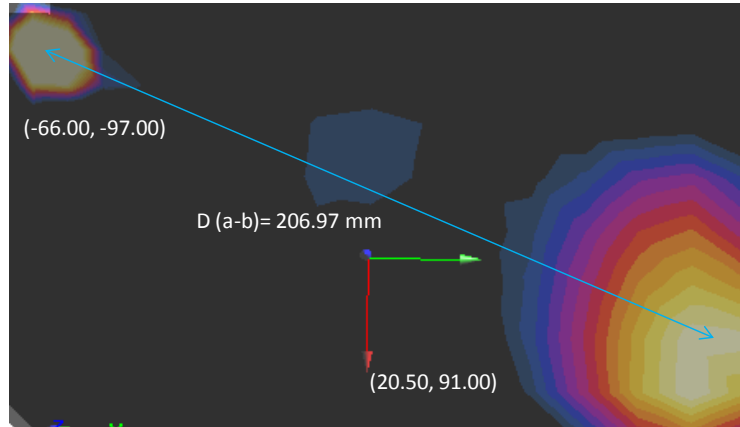

**Figure 11-3**  
**Peak SAR Locations of 5 GHz WLAN and UMTS 850 MHz**

**Table 11-18**  
**SAR Sum to Peak Location Separation Ratio Calculation**

| Antenna Pair |              | Standalone 1g SAR (W/kg) |       | Standalone SAR Sum (W/kg) | Peak SAR Separation Distance (mm) | SPLS Ratio            |
|--------------|--------------|--------------------------|-------|---------------------------|-----------------------------------|-----------------------|
| Ant "a"      | Ant "b"      | a                        | b     | a+b                       | $D_{a-b}$                         | $(a+b)^{1.5}/D_{a-b}$ |
| 5 GHz WLAN   | 850 MHz UMTS | < 1.068                  | 0.545 | < 1.613                   | 206.97                            | <0.01                 |

The sum of the standalone SAR values was above 1.6 W/kg for the Body Back side configuration at a separation distance of 12 mm with UMTS 1900 MHz antenna operating at max output power with 5 GHz WIFI.

**Table 11-19**  
**Peak SAR Locations for Body Back Side at 12 mm UMTS 1900 MHz and 5 GHz WLAN**

| Mode/Band     | x (mm) | y (mm) |
|---------------|--------|--------|
| 5 GHz WLAN    | -66.00 | -97.00 |
| 1900 MHz UMTS | 20.50  | 101.00 |

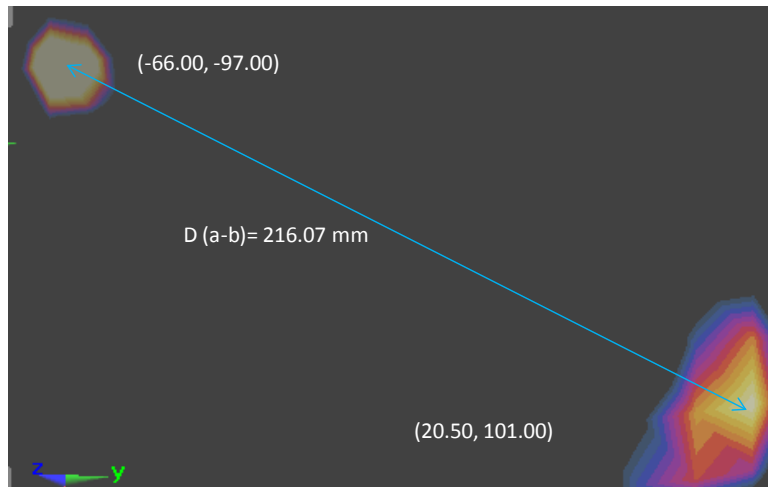

**Figure 11-4**  
**Peak SAR Locations of 5 GHz WLAN and UMT 1900 MHz**

**Table 11-20**  
**SAR Sum to Peak Location Separation Ratio Calculation**

| Antenna Pair |               | Standalone 1g SAR (W/kg) |       | Standalone SAR Sum (W/kg) | Peak SAR Separation Distance (mm) | SPLS Ratio            |
|--------------|---------------|--------------------------|-------|---------------------------|-----------------------------------|-----------------------|
| Ant "a"      | Ant "b"       | a                        | b     | a+b                       | $D_{a-b}$                         | $(a+b)^{1.5}/D_{a-b}$ |
| 5 GHz WLAN   | 1900 MHz UMTS | < 1.068                  | 0.734 | <1.802                    | 216.07                            | < 0.01                |

## 11.6 Simultaneous Transmission Conclusion

The above numerical summed SAR and SPLSR analysis results for all the worst-case simultaneous transmission conditions were below the SAR limit. Therefore, the above analysis is sufficient to determine that simultaneous transmission cases will not exceed the SAR limit and therefore no measured volumetric simultaneous SAR summation is required per FCC KDB Publication 447498 D01v05 and IEEE 1528-2013 Section 6.3.4.1.2.

|                                   |  |                              |  |                                 |
|-----------------------------------|--|------------------------------|--|---------------------------------|
| FCC ID: A3LSMT331                 | PCTEST<br>ENGINEERING LABORATORY, INC. | SAR EVALUATION REPORT        |  | Reviewed by:<br>Quality Manager |
| Document S/N:<br>0Y1312302508.A3L | Test Dates:<br>01/06/2014-01/24/2014   | DUT Type:<br>Portable Tablet |  | Page 40 of 47                   |

## 12 SAR MEASUREMENT VARIABILITY

### 12.1 Measurement Variability

Per FCC KDB Publication 865664 D01v01, SAR measurement variability was assessed for each frequency band, which was determined by the SAR probe calibration point and tissue-equivalent medium used for the device measurements. When both head and body tissue-equivalent media were required for SAR measurements in a frequency band, the variability measurement procedures were applied to the tissue medium with the highest measured SAR, using the highest measured SAR configuration for that tissue-equivalent medium. These additional measurements were repeated after the completion of all measurements requiring the same head or body tissue-equivalent medium in a frequency band. The test device was returned to ambient conditions (normal room temperature) with the battery fully charged before it was re-mounted on the device holder for the repeated measurement(s) to minimize any unexpected variations in the repeated results.

SAR Measurement Variability was assessed using the following procedures for each frequency band:



- 1) When the original highest measured SAR is  $\geq 0.80$  W/kg, the measurement was repeated once.
- 2) A second repeated measurement was performed only if the ratio of largest to smallest SAR for the original and first repeated measurements was  $> 1.20$  or when the original or repeated measurement was  $\geq 1.45$  W/kg ( $\sim 10\%$  from the 1-g SAR limit).
- 3) A third repeated measurement was performed only if the original, first or second repeated measurement was  $\geq 1.5$  W/kg and the ratio of largest to smallest SAR for the original, first and second repeated measurements is  $> 1.20$ .
- 4) Repeated measurements are not required when the original highest measured SAR is  $< 0.80$  W/kg

**Table 12-1  
Body SAR Measurement Variability Result**

| BODY VARIABILITY RESULTS  |           |      |              |         |                 |                  |      |   |                   |                       |       |                       |       |                       |       |
|---|-----------|------|--------------|---------|-----------------|------------------|------|---|-------------------|-----------------------|-------|-----------------------|-------|-----------------------|-------|
| Band  | FREQUENCY |      | Mode         | Service | # of Time Slots | Data Rate (Mbps) | Side | Spacing   | Measured SAR (1g) | 1st Repeated SAR (1g) | Ratio | 2nd Repeated SAR (1g) | Ratio | 3rd Repeated SAR (1g) | Ratio |
|   | MHz       | Ch.  |              |         |                 |                  |      |   | (W/kg)            | (W/kg)                |       | (W/kg)                |       | (W/kg)                |       |
| 835   | 824.20    | 128  | GSM 850      | GPRS    | 3               | N/A              | back | 0 mm  | 0.909             | 0.839                 | 1.08  | N/A                   | N/A   | N/A                   | N/A   |
| 1900  | 1880.00   | 9400 | UMTS 1900    | RMC     | N/A             | N/A              | top  | 9 mm  | 0.818             | 0.833                 | 1.02  | N/A                   | N/A   | N/A                   | N/A   |
| 5200  | 5220.00   | 44   | IEEE 802.11a | OFDM    | N/A             | 6                | back | 0 mm  | 0.838             | 0.928                 | 1.11  | N/A                   | N/A   | N/A                   | N/A   |
| 5300  | 5300.00   | 60   | IEEE 802.11a | OFDM    | N/A             | 6                | back | 0 mm  | 0.945             | 0.948                 | 1.00  | N/A                   | N/A   | N/A                   | N/A   |
| 5500  | 5540.00   | 108  | IEEE 802.11a | OFDM    | N/A             | 6                | back | 0 mm  | 0.831             | 0.837                 | 1.01  | N/A                   | N/A   | N/A                   | N/A   |
| 5600  | 5580.00   | 116  | IEEE 802.11a | OFDM    | N/A             | 6                | back | 0 mm  | 0.863             | 0.860                 | 1.00  | N/A                   | N/A   | N/A                   | N/A   |
| ANSI / IEEE C95.1 1992 - SAFETY LIMIT<br>Spatial Peak<br>Uncontrolled Exposure/General Population |           |      |              |         |                 |                  |      | Body<br>1.6 W/kg (mW/g)<br>averaged over 1 gram |                   |                       |       |                       |       |                       |       |

### 12.2 Measurement Uncertainty



The measured SAR was  $< 1.5$  W/kg for all frequency bands. Therefore, per KDB Publication 865664 D01v01, the extended measurement uncertainty analysis per IEEE 1528-2003 was not required.

|                                   |  |                              |   |                                 |
|-----------------------------------|--|------------------------------|---|---------------------------------|
| FCC ID: A3LSMT331                 |  PCTEST<br>ENGINEERING LABORATORY, INC. | SAR EVALUATION REPORT        |  | Reviewed by:<br>Quality Manager |
| Document S/N:<br>0Y1312302508.A3L | Test Dates:<br>01/06/2014-01/24/2014   | DUT Type:<br>Portable Tablet |   | Page 41 of 47                   |

# 13 EQUIPMENT LIST

| Manufacturer       | Model           | Description                                   | Cal Date   | Cal Interval | Cal Due    | Serial Number |
|--------------------|-----------------|---|------------|--------------|------------|---------------|
| Agilent            | 8753E           | (30kHz-6GHz) Network Analyzer                 | 4/16/2013  | Annual       | 4/16/2014  | JP38020182    |
| Agilent            | E8257D          | (250kHz-20GHz) Signal Generator               | 4/16/2013  | Annual       | 4/16/2014  | MY45470194    |
| Agilent            | N9020A          | MXA Signal Analyzer                           | 10/29/2013 | Annual       | 10/29/2014 | US46470561    |
| Agilent            | 8648D           | (9kHz-4GHz) Signal Generator                  | 4/17/2013  | Annual       | 4/17/2014  | 3629U00687    |
| Agilent            | E5515C          | Wireless Communications Test Set              | 5/9/2013   | Biennial     | 5/9/2015   | GB43304447    |
| Agilent            | 8753E           | (30kHz-6GHz) Network Analyzer                 | 7/23/2013  | Annual       | 7/23/2014  | US37390350    |
| Agilent            | N4010A          | Wireless Connectivity Test Set                | N/A        | N/A          | N/A        | GB46170464    |
| Agilent            | E5515C          | Wireless Communications Test Set              | 10/18/2012 | Biennial     | 10/18/2014 | GB43193563    |
| Agilent            | 85047A          | S-Parameter Test Set                          | N/A        | N/A          | N/A        | 2904A00579    |
| Agilent            | N5182A          | MXG Vector Signal Generator                   | 10/28/2013 | Annual       | 10/28/2014 | US46240505    |
| Agilent            | 8753ES          | S-Parameter Network Analyzer                  | 10/29/2013 | Annual       | 10/29/2014 | US39170122    |
| Amplifier Research | 5S1G4           | 5W, 800MHz-4.2GHz                             | CBT        | N/A          | CBT        | 21910         |
| Anritsu            | MT8820C         | Radio Communication Analyzer                  | 12/12/2013 | Annual       | 12/12/2014 | 6200901190    |
| Anritsu            | MA2411B         | Pulse Power Sensor                            | 11/14/2013 | Annual       | 11/14/2014 | 1126066       |
| Anritsu            | MT8820C         | Radio Communication Analyzer                  | 6/28/2013  | Annual       | 6/28/2014  | 6201240328    |
| Anritsu            | ML2495A         | Power Meter                                   | 10/31/2013 | Annual       | 10/31/2014 | 0941001       |
| Anritsu            | MA24106A        | USB Power Sensor                              | 1/3/2014   | Annual       | 1/3/2015   | 1349503       |
| Anritsu            | MA24106A        | USB Power Sensor                              | 1/3/2014   | Annual       | 1/3/2015   | 1349509       |
| Anritsu            | MA24106A        | USB Power Sensor                              | 1/3/2014   | Annual       | 1/3/2015   | 1349511       |
| COMTECH            | AR85729-5/5759B | Solid State Amplifier                         | CBT        | N/A          | CBT        | M3W1A00-1002  |
| COMTECH            | AR85729-5       | Solid State Amplifier                         | CBT        | N/A          | CBT        | M1S5A00-009   |
| Gigatronics        | 80701A          | (0.05-18GHz) Power Sensor                     | 10/30/2013 | Annual       | 10/30/2014 | 1833460       |
| Gigatronics        | 8651A           | Universal Power Meter                         | 10/30/2013 | Annual       | 10/30/2014 | 8650319       |
| MCL                | BW-N6W5+        | 6dB Attenuator                                | CBT        | N/A          | CBT        | 1139          |
| MiniCircuits       | SLP-2400+       | Low Pass Filter                               | CBT        | N/A          | CBT        | R8979500903   |
| MiniCircuits       | VLF-6000+       | Low Pass Filter                               | CBT        | N/A          | CBT        | N/A           |
| Mini-Circuits      | BW-N20W5+       | DC to 18 GHz Precision Fixed 20 dB Attenuator | CBT        | N/A          | CBT        | N/A           |
| Mini-Circuits      | NLP-2950+       | Low Pass Filter DC to 2700 MHz                | CBT        | N/A          | CBT        | N/A           |
| Mini-Circuits      | NLP-1200+       | Low Pass Filter DC to 1000 MHz                | CBT        | N/A          | CBT        | N/A           |
| Mini-Circuits      | BW-N20W5        | Power Attenuator                              | CBT        | N/A          | CBT        | 1226          |
| Narda              | BW-S3W2         | Attenuator (3dB)                              | CBT        | N/A          | CBT        | 120           |
| Narda              | 4014C-6         | 4 - 8 GHz SMA 6 dB Directional Coupler        | CBT        | N/A          | CBT        | N/A           |
| Pasternack         | PE2208-6        | Bidirectional Coupler                         | CBT        | N/A          | CBT        | N/A           |
| Pasternack         | PE2209-10       | Bidirectional Coupler                         | CBT        | N/A          | CBT        | N/A           |
| Rohde & Schwarz    | CMU200          | Base Station Simulator                        | 5/3/2013   | Annual       | 5/3/2014   | 836371/0079   |
| Rohde & Schwarz    | NRVD            | Dual Channel Power Meter                      | 10/12/2012 | Biennial     | 10/12/2014 | 101695        |
| Rohde & Schwarz    | NRVS            | Single Channel Power Meter                    | 10/31/2013 | Annual       | 10/31/2014 | 835360/0079   |
| Rohde & Schwarz    | NRV-Z32         | Peak Power Sensor                             | 10/12/2012 | Biennial     | 10/12/2014 | 836019/013    |
| Rohde & Schwarz    | SMIQ03B         | Signal Generator                              | 4/17/2013  | Annual       | 4/17/2014  | DE27259       |
| Rohde & Schwarz    | SME06           | Signal Generator                              | 10/30/2013 | Annual       | 10/30/2014 | 832026        |
| Rohde & Schwarz    | CMW500          | Radio Communication Tester                    | 10/4/2013  | Annual       | 10/4/2014  | 108798        |
| Seekonk            | NC-100          | Torque Wrench (8" lb)                         | 11/29/2011 | Triennial    | 11/29/2014 | 21053         |
| SPEAG              | D2450V2         | 2450 MHz SAR Dipole                           | 8/23/2013  | Annual       | 8/23/2014  | 719           |
| SPEAG              | ES3DV2          | SAR Probe                                     | 8/22/2013  | Annual       | 8/22/2014  | 3022          |
| SPEAG              | DAE4            | Dasy Data Acquisition Electronics             | 5/13/2013  | Annual       | 5/13/2014  | 859           |
| SPEAG              | ES3DV3          | SAR Probe                                     | 3/15/2013  | Annual       | 3/15/2014  | 3209          |
| SPEAG              | ES3DV3          | SAR Probe                                     | 5/16/2013  | Annual       | 5/16/2014  | 3263          |
| SPEAG              | D835V2          | 835 MHz SAR Dipole                            | 4/25/2013  | Annual       | 4/25/2014  | 4d119         |
| SPEAG              | D2450V2         | 2450 MHz SAR Dipole                           | 2/11/2013  | Annual       | 2/11/2014  | 882           |
| SPEAG              | D1900V2         | 1900 MHz SAR Dipole                           | 7/22/2013  | Annual       | 7/22/2014  | 5d149         |
| SPEAG              | DAE4            | Dasy Data Acquisition Electronics             | 11/19/2013 | Annual       | 11/19/2014 | 1333          |
| SPEAG              | D5GHzV2         | 5 GHz SAR Dipole                              | 2/14/2013  | Annual       | 2/14/2014  | 1120          |
| SPEAG              | D1900V2         | 1900 MHz SAR Dipole                           | 2/6/2013   | Annual       | 2/6/2014   | 5d148         |
| SPEAG              | DAE4            | Dasy Data Acquisition Electronics             | 8/21/2013  | Annual       | 8/21/2014  | 1322          |
| SPEAG              | DAE4            | Dasy Data Acquisition Electronics             | 3/8/2013   | Annual       | 3/8/2014   | 1334          |
| SPEAG              | EX3DV4          | SAR Probe                                     | 10/23/2013 | Annual       | 10/23/2014 | 3914          |
| SPEAG              | ES3DV3          | SAR Probe                                     | 4/29/2013  | Annual       | 4/29/2014  | 3319          |
| SPEAG              | DAE4            | Dasy Data Acquisition Electronics             | 4/22/2013  | Annual       | 4/22/2014  | 1368          |
| SPEAG              | ES3DV3          | SAR Probe                                     | 11/22/2013 | Annual       | 11/22/2014 | 3333          |
| SPEAG              | DAE4            | Dasy Data Acquisition Electronics             | 11/19/2013 | Annual       | 11/19/2014 | 1408          |
| Tektronix          | RSA6114A        | Real Time Spectrum Analyzer                   | 4/17/2013  | Annual       | 4/17/2014  | B010177       |
| VWR                | 23226-658       | Long Stem Thermometer                         | 3/30/2012  | Biennial     | 3/30/2014  | 122179874     |
| VWR                | 36934-158       | Wall-Mounted Thermometer                      | 8/8/2013   | Annual       | 8/8/2014   | 130477877     |

Note: CBT (Calibrated Before Testing). Prior to testing, the measurement paths containing a cable, amplifier, attenuator, coupler or filter were connected to a calibrated source (i.e. a signal generator) to determine the losses of the measurement path. The power meter offset was then adjusted to compensate for the measurement system losses. This level offset is stored within the power meter before measurements are made. This calibration verification procedure applies to the system verification and output power measurements. The calibrated reading is then taken directly from the power meter after compensation of the losses for all final power measurements.



|  |   |                                     |   |  |
|--|---|-------------------------------------|---|--|
| FCC ID: A3LSMT331                        |  <b>PCTEST</b><br>ENGINEERING LABORATORY, INC. | <b>SAR EVALUATION REPORT</b>        |  | <b>Reviewed by:</b><br>Quality Manager |
| <b>Document S/N:</b><br>0Y1312302508.A3L | <b>Test Dates:</b><br>01/06/2014-01/24/2014   | <b>DUT Type:</b><br>Portable Tablet | Page 42 of 47   |  |

# 14 MEASUREMENT UNCERTAINTIES

Applicable for frequencies less than 3000 MHz.

| a   | b                    | c             | d              | e=<br>f(d,k) | f                     | g                        | h =<br>c x f/e                 | i =<br>c x g/e                   | k              |
|---|----------------------|---------------|----------------|--------------|-----------------------|--------------------------|--------------------------------|----------------------------------|----------------|
| Uncertainty<br>Component  | IEEE<br>1528<br>Sec. | Tol.<br>(± %) | Prob.<br>Dist. | Div.         | c <sub>i</sub><br>1gm | c <sub>i</sub><br>10 gms | 1gm<br>u <sub>i</sub><br>(± %) | 10gms<br>u <sub>i</sub><br>(± %) | v <sub>i</sub> |
| <b>Measurement System</b>   |                      |               |                |              |                       |                          |                                |                                  |                |
| Probe Calibration   | E.2.1                | 6.0           | N              | 1            | 1.0                   | 1.0                      | 6.0                            | 6.0                              | ∞              |
| Axial Isotropy  | E.2.2                | 0.25          | N              | 1            | 0.7                   | 0.7                      | 0.2                            | 0.2                              | ∞              |
| Hemishperical Isotropy  | E.2.2                | 1.3           | N              | 1            | 1.0                   | 1.0                      | 1.3                            | 1.3                              | ∞              |
| Boundary Effect   | E.2.3                | 0.4           | N              | 1            | 1.0                   | 1.0                      | 0.4                            | 0.4                              | ∞              |
| Linearity   | E.2.4                | 0.3           | N              | 1            | 1.0                   | 1.0                      | 0.3                            | 0.3                              | ∞              |
| System Detection Limits   | E.2.5                | 5.1           | N              | 1            | 1.0                   | 1.0                      | 5.1                            | 5.1                              | ∞              |
| Readout Electronics   | E.2.6                | 1.0           | N              | 1            | 1.0                   | 1.0                      | 1.0                            | 1.0                              | ∞              |
| Response Time   | E.2.7                | 0.8           | R              | 1.73         | 1.0                   | 1.0                      | 0.5                            | 0.5                              | ∞              |
| Integration Time  | E.2.8                | 2.6           | R              | 1.73         | 1.0                   | 1.0                      | 1.5                            | 1.5                              | ∞              |
| RF Ambient Conditions   | E.6.1                | 3.0           | R              | 1.73         | 1.0                   | 1.0                      | 1.7                            | 1.7                              | ∞              |
| Probe Positioner Mechanical Tolerance   | E.6.2                | 0.4           | R              | 1.73         | 1.0                   | 1.0                      | 0.2                            | 0.2                              | ∞              |
| Probe Positioning w/ respect to Phantom                                       | E.6.3                | 2.9           | R              | 1.73         | 1.0                   | 1.0                      | 1.7                            | 1.7                              | ∞              |
| Extrapolation, Interpolation & Integration algorithms for Max. SAR Evaluation | E.5                  | 1.0           | R              | 1.73         | 1.0                   | 1.0                      | 0.6                            | 0.6                              | ∞              |
| <b>Test Sample Related</b>  |                      |               |                |              |                       |                          |                                |                                  |                |
| Test Sample Positioning   | E.4.2                | 6.0           | N              | 1            | 1.0                   | 1.0                      | 6.0                            | 6.0                              | 287            |
| Device Holder Uncertainty   | E.4.1                | 3.32          | R              | 1.73         | 1.0                   | 1.0                      | 1.9                            | 1.9                              | ∞              |
| Output Power Variation - SAR drift measurement                                | 6.6.2                | 5.0           | R              | 1.73         | 1.0                   | 1.0                      | 2.9                            | 2.9                              | ∞              |
| <b>Phantom &amp; Tissue Parameters</b>  |                      |               |                |              |                       |                          |                                |                                  |                |
| Phantom Uncertainty (Shape & Thickness tolerances)                            | E.3.1                | 4.0           | R              | 1.73         | 1.0                   | 1.0                      | 2.3                            | 2.3                              | ∞              |
| Liquid Conductivity - deviation from target values                            | E.3.2                | 5.0           | R              | 1.73         | 0.64                  | 0.43                     | 1.8                            | 1.2                              | ∞              |
| Liquid Conductivity - measurement uncertainty                                 | E.3.3                | 3.8           | N              | 1            | 0.64                  | 0.43                     | 2.4                            | 1.6                              | 6              |
| Liquid Permittivity - deviation from target values                            | E.3.2                | 5.0           | R              | 1.73         | 0.60                  | 0.49                     | 1.7                            | 1.4                              | ∞              |
| Liquid Permittivity - measurement uncertainty                                 | E.3.3                | 4.5           | N              | 1            | 0.60                  | 0.49                     | 2.7                            | 2.2                              | 6              |
| <b>Combined Standard Uncertainty (k=1)</b>                                    |                      |               |                | RSS          |                       |                          | 12.1                           | 11.7                             | 299            |
| <b>Expanded Uncertainty<br/>(95% CONFIDENCE LEVEL)</b>                        |                      |               |                | k=2          |                       |                          | 24.2                           | 23.5                             |                |



The above measurement uncertainties are according to IEEE Std. 1528-2003

|  |   |                                     |   |  |
|--|---|-------------------------------------|---|--|
| FCC ID: A3LSMT331                        |  <b>PCTEST</b><br>ENGINEERING LABORATORY, INC. | <b>SAR EVALUATION REPORT</b>        |  | <b>Reviewed by:</b><br>Quality Manager |
| <b>Document S/N:</b><br>0Y1312302508.A3L | <b>Test Dates:</b><br>01/06/2014-01/24/2014   | <b>DUT Type:</b><br>Portable Tablet | Page 43 of 47   |  |

Applicable for frequencies up to 6 GHz.

| a   | b                    | c             | d              | e=<br>f(d,k) | f                     | g                        | h=<br>c x f/e                  | i=<br>c x g/e                    | k              |     |
|---|----------------------|---------------|----------------|--------------|-----------------------|--------------------------|--------------------------------|----------------------------------|----------------|-----|
| Uncertainty<br>Component  | IEEE<br>1528<br>Sec. | Tol.<br>(± %) | Prob.<br>Dist. | Div.         | c <sub>i</sub><br>1gm | c <sub>i</sub><br>10 gms | 1gm<br>u <sub>i</sub><br>(± %) | 10gms<br>u <sub>i</sub><br>(± %) | v <sub>i</sub> |     |
| <b>Measurement System</b>   |                      |               |                |              |                       |                          |                                |                                  |                |     |
| Probe Calibration   | E.2.1                | 6.55          | N              | 1            | 1.0                   | 1.0                      | 6.6                            | 6.6                              | ∞              |     |
| Axial Isotropy  | E.2.2                | 0.25          | N              | 1            | 0.7                   | 0.7                      | 0.2                            | 0.2                              | ∞              |     |
| Hemishperical Isotropy  | E.2.2                | 1.3           | N              | 1            | 1.0                   | 1.0                      | 1.3                            | 1.3                              | ∞              |     |
| Boundary Effect   | E.2.3                | 0.4           | N              | 1            | 1.0                   | 1.0                      | 0.4                            | 0.4                              | ∞              |     |
| Linearity   | E.2.4                | 0.3           | N              | 1            | 1.0                   | 1.0                      | 0.3                            | 0.3                              | ∞              |     |
| System Detection Limits   | E.2.5                | 5.1           | N              | 1            | 1.0                   | 1.0                      | 5.1                            | 5.1                              | ∞              |     |
| Readout Electronics   | E.2.6                | 1.0           | N              | 1            | 1.0                   | 1.0                      | 1.0                            | 1.0                              | ∞              |     |
| Response Time   | E.2.7                | 0.8           | R              | 1.73         | 1.0                   | 1.0                      | 0.5                            | 0.5                              | ∞              |     |
| Integration Time  | E.2.8                | 2.6           | R              | 1.73         | 1.0                   | 1.0                      | 1.5                            | 1.5                              | ∞              |     |
| RF Ambient Conditions   | E.6.1                | 3.0           | R              | 1.73         | 1.0                   | 1.0                      | 1.7                            | 1.7                              | ∞              |     |
| Probe Positioner Mechanical Tolerance   | E.6.2                | 0.4           | R              | 1.73         | 1.0                   | 1.0                      | 0.2                            | 0.2                              | ∞              |     |
| Probe Positioning w/ respect to Phantom                                       | E.6.3                | 2.9           | R              | 1.73         | 1.0                   | 1.0                      | 1.7                            | 1.7                              | ∞              |     |
| Extrapolation, Interpolation & Integration algorithms for Max. SAR Evaluation | E.5                  | 1.0           | R              | 1.73         | 1.0                   | 1.0                      | 0.6                            | 0.6                              | ∞              |     |
| <b>Test Sample Related</b>  |                      |               |                |              |                       |                          |                                |                                  |                |     |
| Test Sample Positioning   | E.4.2                | 6.0           | N              | 1            | 1.0                   | 1.0                      | 6.0                            | 6.0                              | 287            |     |
| Device Holder Uncertainty   | E.4.1                | 3.32          | R              | 1.73         | 1.0                   | 1.0                      | 1.9                            | 1.9                              | ∞              |     |
| Output Power Variation - SAR drift measurement                                | 6.6.2                | 5.0           | R              | 1.73         | 1.0                   | 1.0                      | 2.9                            | 2.9                              | ∞              |     |
| <b>Phantom &amp; Tissue Parameters</b>  |                      |               |                |              |                       |                          |                                |                                  |                |     |
| Phantom Uncertainty (Shape & Thickness tolerances)                            | E.3.1                | 4.0           | R              | 1.73         | 1.0                   | 1.0                      | 2.3                            | 2.3                              | ∞              |     |
| Liquid Conductivity - deviation from target values                            | E.3.2                | 5.0           | R              | 1.73         | 0.64                  | 0.43                     | 1.8                            | 1.2                              | ∞              |     |
| Liquid Conductivity - measurement uncertainty                                 | E.3.3                | 3.8           | N              | 1            | 0.64                  | 0.43                     | 2.4                            | 1.6                              | 6              |     |
| Liquid Permittivity - deviation from target values                            | E.3.2                | 5.0           | R              | 1.73         | 0.60                  | 0.49                     | 1.7                            | 1.4                              | ∞              |     |
| Liquid Permittivity - measurement uncertainty                                 | E.3.3                | 4.5           | N              | 1            | 0.60                  | 0.49                     | 2.7                            | 2.2                              | 6              |     |
| <b>Combined Standard Uncertainty (k=1)</b>                                    |                      |               |                |              |                       |                          | RSS                            | 12.4                             | 12.0           | 299 |
| <b>Expanded Uncertainty</b><br>(95% CONFIDENCE LEVEL)                         |                      |               |                |              |                       |                          | k=2                            | 24.7                             | 24.0           |     |

The above measurement uncertainties are according to IEEE Std. 1528-2003



|  |   |                                     |   |  |
|--|---|-------------------------------------|---|--|
| FCC ID: A3LSMT331                        |  | <b>SAR EVALUATION REPORT</b>        |  | <b>Reviewed by:</b><br>Quality Manager |
| <b>Document S/N:</b><br>0Y1312302508.A3L | <b>Test Dates:</b><br>01/06/2014-01/24/2014   | <b>DUT Type:</b><br>Portable Tablet |   | Page 44 of 47                          |

## 15 CONCLUSION

### 15.1 Measurement Conclusion



The SAR evaluation indicates that the EUT complies with the RF radiation exposure limits of the FCC and Industry Canada, with respect to all parameters subject to this test. These measurements were taken to simulate the RF effects of RF exposure under worst-case conditions. Precise laboratory measures were taken to assure repeatability of the tests. The results and statements relate only to the item(s) tested.

Please note that the absorption and distribution of electromagnetic energy in the body are very complex phenomena that depend on the mass, shape, and size of the body, the orientation of the body with respect to the field vectors, and the electrical properties of both the body and the environment. Other variables that may play a substantial role in possible biological effects are those that characterize the environment (e.g. ambient temperature, air velocity, relative humidity, and body insulation) and those that characterize the individual (e.g. age, gender, activity level, debilitation, or disease). Because various factors may interact with one another to vary the specific biological outcome of an exposure to electromagnetic fields, any protection guide should consider maximal amplification of biological effects as a result of field-body interactions, environmental conditions, and physiological variables. [3]



|  |   |                                     |   |  |
|--|---|-------------------------------------|---|--|
| <b>FCC ID:</b> A3LSMT331                 |  | <b>SAR EVALUATION REPORT</b>        |  | <b>Reviewed by:</b><br>Quality Manager |
| <b>Document S/N:</b><br>0Y1312302508.A3L | <b>Test Dates:</b><br>01/06/2014-01/24/2014   | <b>DUT Type:</b><br>Portable Tablet |   | Page 45 of 47                          |

## 16 REFERENCES

- [1] Federal Communications Commission, ET Docket 93-62, Guidelines for Evaluating the Environmental Effects of Radiofrequency Radiation, Aug. 1996.
- [2] ANSI/IEEE C95.1-2005, American National Standard safety levels with respect to human exposure to radio frequency electromagnetic fields, 3kHz to 300GHz, New York: IEEE, 2006.
- [3] ANSI/IEEE C95.1-1992, American National Standard safety levels with respect to human exposure to radio frequency electromagnetic fields, 3kHz to 300GHz, New York: IEEE, Sept. 1992.
- [4] ANSI/IEEE C95.3-2002, IEEE Recommended Practice for the Measurement of Potentially Hazardous Electromagnetic Fields - RF and Microwave, New York: IEEE, December 2002.
- [5] IEEE Standards Coordinating Committee 39 –Standards Coordinating Committee 34 – IEEE Std. 1528-2003, Recommended Practice for Determining the Peak Spatial-Average Specific Absorption Rate (SAR) in the Human Body Due to Wireless Communications Devices.
- [6] NCRP, National Council on Radiation Protection and Measurements, Biological Effects and Exposure Criteria for RadioFrequency Electromagnetic Fields, NCRP Report No. 86, 1986. Reprinted Feb. 1995.
- [7] T. Schmid, O. Egger, N. Kuster, Automated E-field scanning system for dosimetric assessments, IEEE Transaction on Microwave Theory and Techniques, vol. 44, Jan. 1996, pp. 105-113.
- [8] K. Pokovic, T. Schmid, N. Kuster, Robust setup for precise calibration of E-field probes in tissue simulating liquids at mobile communications frequencies, ICECOM97, Oct. 1997, pp. -124.
- [9] K. Pokovic, T. Schmid, and N. Kuster, E-field Probe with improved isotropy in brain simulating liquids, Proceedings of the ELMAR, Zadar, Croatia, June 23-25, 1996, pp. 172-175.
- [10] Schmid & Partner Engineering AG, Application Note: Data Storage and Evaluation, June 1998, p2.
- [11] V. Hombach, K. Meier, M. Burkhardt, E. Kuhn, N. Kuster, The Dependence of EM Energy Absorption upon Human Modeling at 900 MHz, IEEE Transaction on Microwave Theory and Techniques, vol. 44 no. 10, Oct. 1996, pp. 1865-1873.
- [12] N. Kuster and Q. Balzano, Energy absorption mechanism by biological bodies in the near field of dipole antennas above 300MHz, IEEE Transaction on Vehicular Technology, vol. 41, no. 1, Feb. 1992, pp. 17-23.
- [13] G. Hartsgrove, A. Kraszewski, A. Surowiec, Simulated Biological Materials for Electromagnetic Radiation Absorption Studies, University of Ottawa, Bioelectromagnetics, Canada: 1987, pp. 29-36.
- [14] Q. Balzano, O. Garay, T. Manning Jr., Electromagnetic Energy Exposure of Simulated Users of Portable Cellular Telephones, IEEE Transactions on Vehicular Technology, vol. 44, no.3, Aug. 1995.
- [15] W. Gander, Computermathematick, Birkhaeuser, Basel, 1992.
- [16] W.H. Press, S.A. Teukolsky, W.T. Vetterling, and B.P. Flannery, Numerical Recipes in C, The Art of Scientific Computing, Second edition, Cambridge University Press, 1992.
- [17] N. Kuster, R. Kastle, T. Schmid, Dosimetric evaluation of mobile communications equipment with known precision, IEEE Transaction on Communications, vol. E80-B, no. 5, May 1997, pp. 645-652.
- [18] CENELEC CLC/SC111B, European Prestandard (prENV 50166-2), Human Exposure to Electromagnetic Fields High-frequency: 10kHz-300GHz, Jan. 1995.

|  |   |                                     |   |  |
|--|---|-------------------------------------|---|--|
| <b>FCC ID:</b> A3LSMT331                 |  | <b>SAR EVALUATION REPORT</b>        |  | <b>Reviewed by:</b><br>Quality Manager |
| <b>Document S/N:</b><br>0Y1312302508.A3L | <b>Test Dates:</b><br>01/06/2014-01/24/2014   | <b>DUT Type:</b><br>Portable Tablet | Page 46 of 47   |  |

- [19] Prof. Dr. Niels Kuster, ETH, Eidgenössische Technische Hochschule Zürich, Dosimetric Evaluation of the Cellular Phone.
- [20] IEC 62209-1, Human exposure to radio frequency fields from hand-held and body-mounted wireless communication devices - Human models, instrumentation, and procedures - Part 1: Procedure to determine the specific absorption rate (SAR) for hand-held devices used in close proximity to the ear (frequency range of 300 MHz to 3 GHz), Feb. 2005.
- [21] Industry Canada RSS-102 Radio Frequency Exposure Compliance of Radiocommunication Apparatus (All Frequency Bands) Issue 4, March 2010.
- [22] Health Canada Safety Code 6 Limits of Human Exposure to Radio Frequency Electromagnetic Fields in the Frequency Range from 3 kHz – 300 GHz, 2009
- [23] FCC SAR Test Procedures for 2G-3G Devices, Mobile Hotspot and UMPC Devices KDB Publications 941225, D01-D07
- [24] SAR Measurement procedures for IEEE 802.11a/b/g KDB Publication 248227 D01v01r02
- [25] FCC SAR Considerations for Handsets with Multiple Transmitters and Antennas, KDB Publications 648474 D02-D04
- [26] FCC SAR Evaluation Considerations for Laptop, Notebook, Netbook and Tablet Computers, FCC KDB Publication 616217 D04
- [27] FCC SAR Measurement and Reporting Requirements for 100MHz – 6 GHz, KDB Publications 865664 D01-D02
- [28] FCC General RF Exposure Guidance and SAR Procedures for Dongles, KDB Publication 447498, D01-D02
- [29] Anexo à Resolução No. 533, de 10 de Setembro de 2009.
- [30] IEC 62209-2, Human exposure to radio frequency fields from hand-held and body-mounted wireless communication devices - Human models, instrumentation, and procedures - Part 2: Procedure to determine the specific absorption rate (SAR) for wireless communication devices used in close proximity to the human body (frequency range of 30 MHz to 6 GHz), Mar. 2010.

|  |   |                                     |   |  |
|--|---|-------------------------------------|---|--|
| <b>FCC ID:</b> A3LSMT331                 |  <b>PCTEST</b><br>ENGINEERING LABORATORY, INC. | <b>SAR EVALUATION REPORT</b>        |  | <b>Reviewed by:</b><br>Quality Manager |
| <b>Document S/N:</b><br>0Y1312302508.A3L | <b>Test Dates:</b><br>01/06/2014-01/24/2014   | <b>DUT Type:</b><br>Portable Tablet | Page 47 of 47   |  |

## APPENDIX A: SAR TEST DATA

# PCTEST ENGINEERING LABORATORY, INC.

**DUT: A3LSMT331; Type: Portable Tablet ; Serial: 30-12-02**

Communication System: UID 0, GSM ; Frequency: 824.2 MHz;Duty Cycle: 1:8.3

Medium: 835 Head Medium parameters used (interpolated):

$f = 824.2 \text{ MHz}$ ;  $\sigma = 0.906 \text{ S/m}$ ;  $\epsilon_r = 41.112$ ;  $\rho = 1000 \text{ kg/m}^3$

Phantom section: Right Section

Test Date: 01-06-2014; Ambient Temp: 22.4°C; Tissue Temp: 22.2°C

Probe: ES3DV2 - SN3022; ConvF(6.09, 6.09, 6.09); Calibrated: 8/22/2013;

Sensor-Surface: 4mm (Mechanical Surface Detection)

Electronics: DAE4 Sn1322; Calibrated: 8/21/2013

Phantom: SAM v5.0 front; Type: QD000P40CD; Serial: TP-1646

Measurement SW: DASY52, Version 52.8 (7); SEMCAD X Version 14.6.10 (7164)

**Mode: GSM 850, Right Head, Cheek, Low ch**

**Area Scan (13x17x1):** Measurement grid: dx=15mm, dy=15mm

**Zoom Scan (5x6x7)/Cube 0:** Measurement grid: dx=8mm, dy=8mm, dz=5mm

Reference Value = 29.608 V/m; Power Drift = -0.02 dB

Peak SAR (extrapolated) = 1.53 W/kg

**SAR(1 g) = 0.785 W/kg**

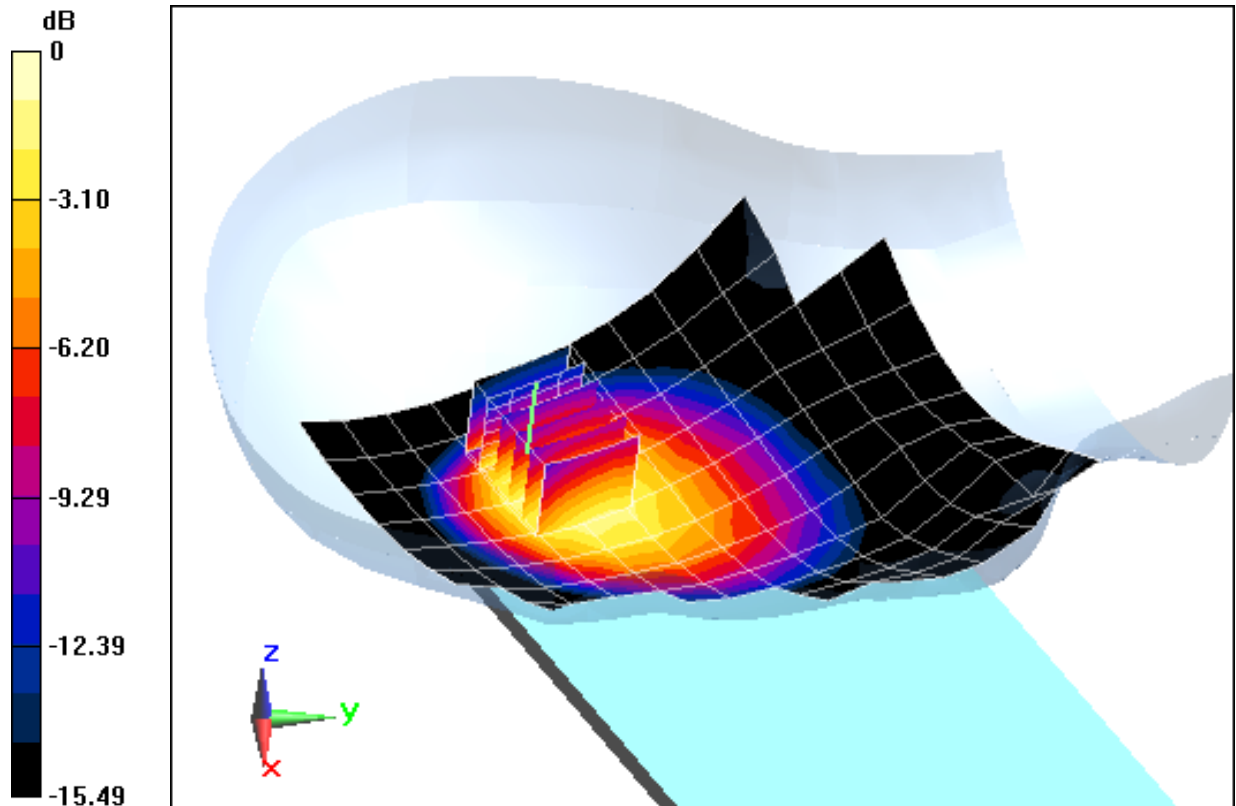

0 dB = 0.808 W/kg = -0.93 dBW/kg

# PCTEST ENGINEERING LABORATORY, INC.

**DUT: A3LSMT331; Type: Portable Tablet; Serial: 30-12-02**

Communication System: UID 0, GSM; Frequency: 1880 MHz; Duty Cycle: 1:8:3

Medium: 1900 Head Medium parameters used:

$f = 1880 \text{ MHz}$ ;  $\sigma = 1.417 \text{ S/m}$ ;  $\epsilon_r = 39.234$ ;  $\rho = 1000 \text{ kg/m}^3$

Phantom section: Right Section

Test Date: 01-08-2014; Ambient Temp: 23.9°C; Tissue Temp: 21.1°C

Probe: ES3DV3 - SN3209; ConvF(5.21, 5.21, 5.21); Calibrated: 3/15/2013;

Sensor-Surface: 4mm (Mechanical Surface Detection)

Electronics: DAE4 Sn1334; Calibrated: 3/8/2013

Phantom: SAM Front; Type: SAM; Serial: 1686

Measurement SW: DASY52, Version 52.8 (7); SEMCAD X Version 14.6.10 (7164)

**Mode: GSM 1900, Right Head, Cheek, Mid.ch**

**Area Scan (11x15x1):** Measurement grid: dx=15mm, dy=15mm

**Zoom Scan (5x5x7)/Cube 0:** Measurement grid: dx=8mm, dy=8mm, dz=5mm

Reference Value = 16.933 V/m; Power Drift = 0.16 dB

Peak SAR (extrapolated) = 0.859 W/kg

**SAR(1 g) = 0.418 W/kg**

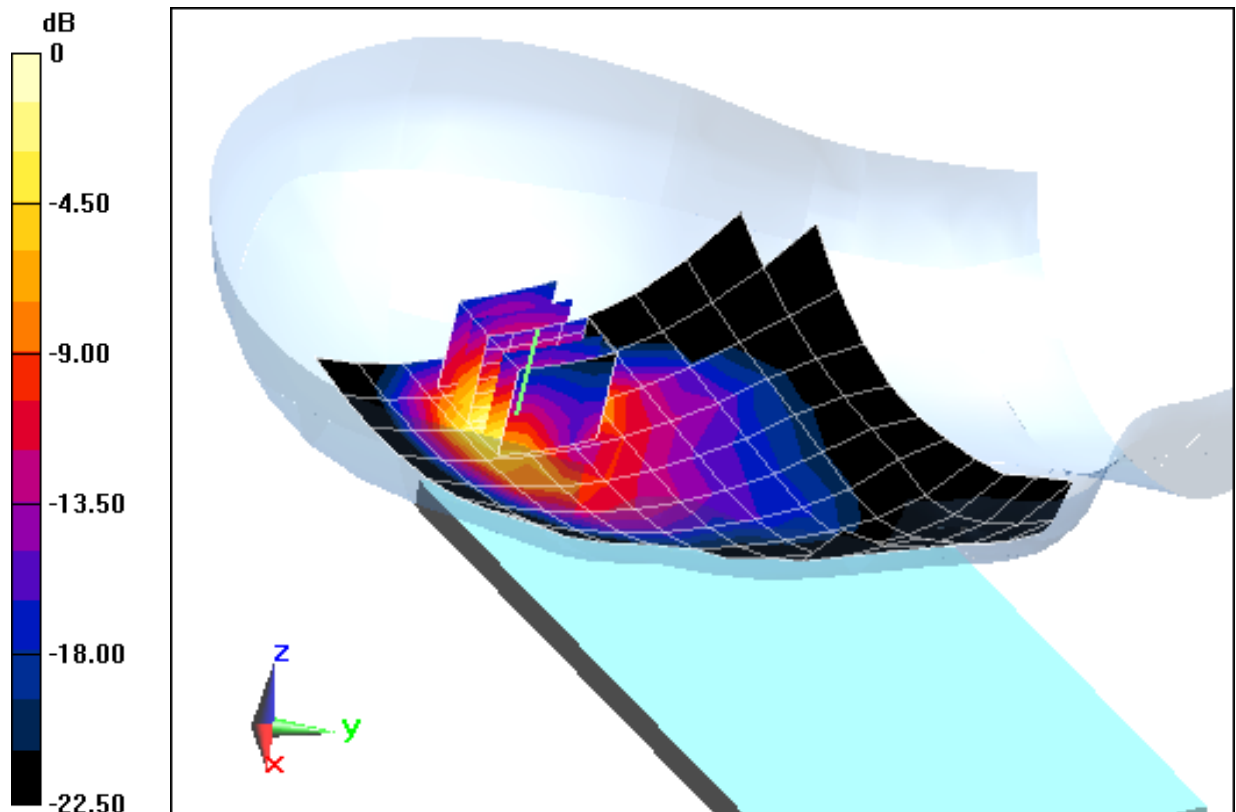

0 dB = 0.498 W/kg = -3.03 dBW/kg

# PCTEST ENGINEERING LABORATORY, INC.

**DUT: A3LSMT331; Type: Portable Tablet ; Serial: 30-12-02**

Communication System: UID 0, UMTS; Frequency: 826.4 MHz; Duty Cycle: 1:1

Medium: 835 Head Medium parameters used (interpolated):

$f = 826.4 \text{ MHz}$ ;  $\sigma = 0.912 \text{ S/m}$ ;  $\epsilon_r = 41.89$ ;  $\rho = 1000 \text{ kg/m}^3$

Phantom section: Right Section

Test Date: 01-08-2014; Ambient Temp: 23.8°C; Tissue Temp: 21.2°C

Probe: ES3DV2 - SN3022; ConvF(6.09, 6.09, 6.09); Calibrated: 8/22/2013;

Sensor-Surface: 4mm (Mechanical Surface Detection)

Electronics: DAE4 Sn1322; Calibrated: 8/21/2013

Phantom: SAM v5.0 front; Type: QD000P40CD; Serial: TP-1646

Measurement SW: DASY52, Version 52.8 (7); SEMCAD X Version 14.6.10 (7164)

**Mode: UMTS 850, Right Head, Cheek, Low ch**

**Area Scan (13x17x1):** Measurement grid: dx=15mm, dy=15mm

**Zoom Scan (5x5x7)/Cube 0:** Measurement grid: dx=8mm, dy=8mm, dz=5mm

Reference Value = 31.454 V/m; Power Drift = 0.07 dB

Peak SAR (extrapolated) = 1.61 W/kg

**SAR(1 g) = 0.883 W/kg**

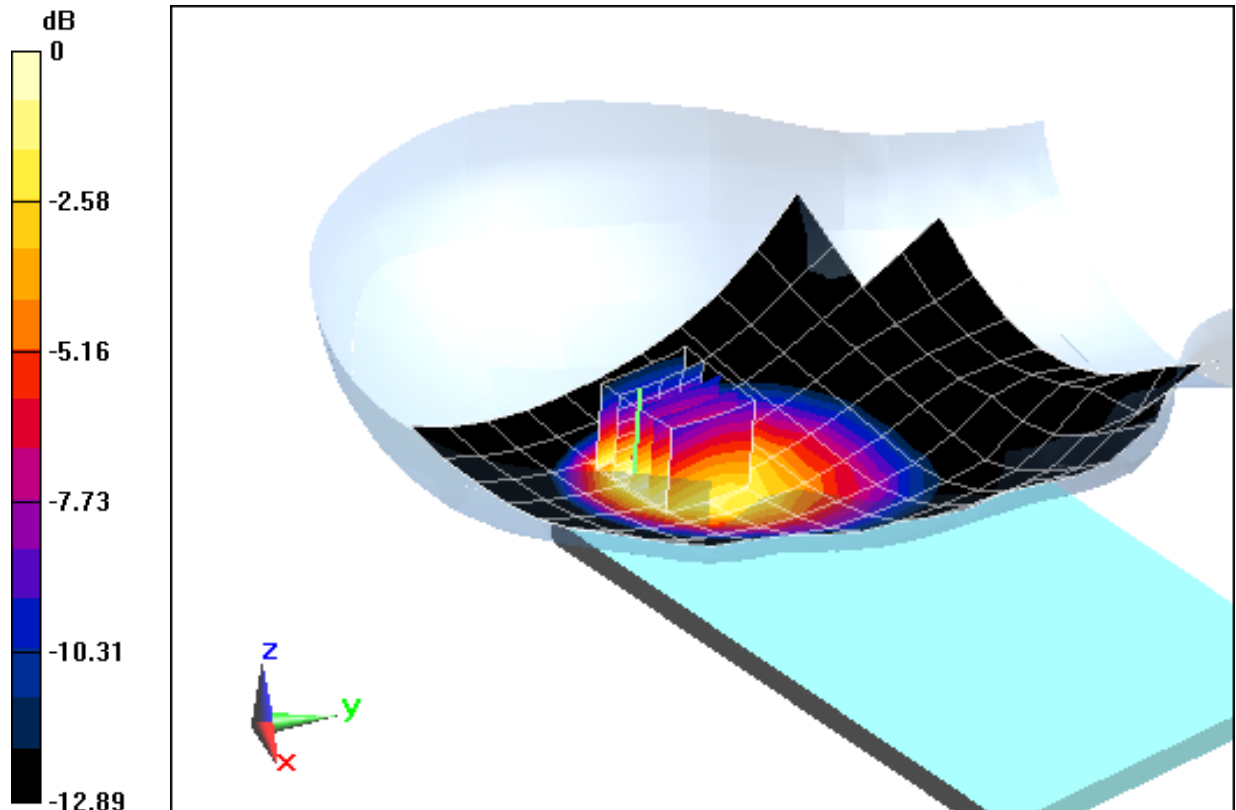

0 dB = 0.926 W/kg = -0.33 dBW/kg

# PCTEST ENGINEERING LABORATORY, INC.

**DUT: A3LSMT331; Type: Portable Tablet; Serial: 30-12-02**

Communication System: UID 0, UMTS; Frequency: 1880 MHz; Duty Cycle: 1:1

Medium: 1900 Head Medium parameters used:

$f = 1880 \text{ MHz}$ ;  $\sigma = 1.417 \text{ S/m}$ ;  $\epsilon_r = 39.234$ ;  $\rho = 1000 \text{ kg/m}^3$

Phantom section: Right Section

Test Date: 01-08-2014; Ambient Temp: 23.9°C; Tissue Temp: 21.1°C

Probe: ES3DV3 - SN3209; ConvF(5.21, 5.21, 5.21); Calibrated: 3/15/2013;

Sensor-Surface: 4mm (Mechanical Surface Detection)

Electronics: DAE4 Sn1334; Calibrated: 3/8/2013

Phantom: SAM Front; Type: SAM; Serial: 1686

Measurement SW: DASY52, Version 52.8 (7); SEMCAD X Version 14.6.10 (7164)

**Mode: UMTS 1900, Right Head, Cheek, Mid.ch**

**Area Scan (11x15x1):** Measurement grid: dx=15mm, dy=15mm

**Zoom Scan (5x5x7)/Cube 0:** Measurement grid: dx=8mm, dy=8mm, dz=5mm

Reference Value = 17.602 V/m; Power Drift = 0.12 dB

Peak SAR (extrapolated) = 0.820 W/kg

**SAR(1 g) = 0.399 W/kg**

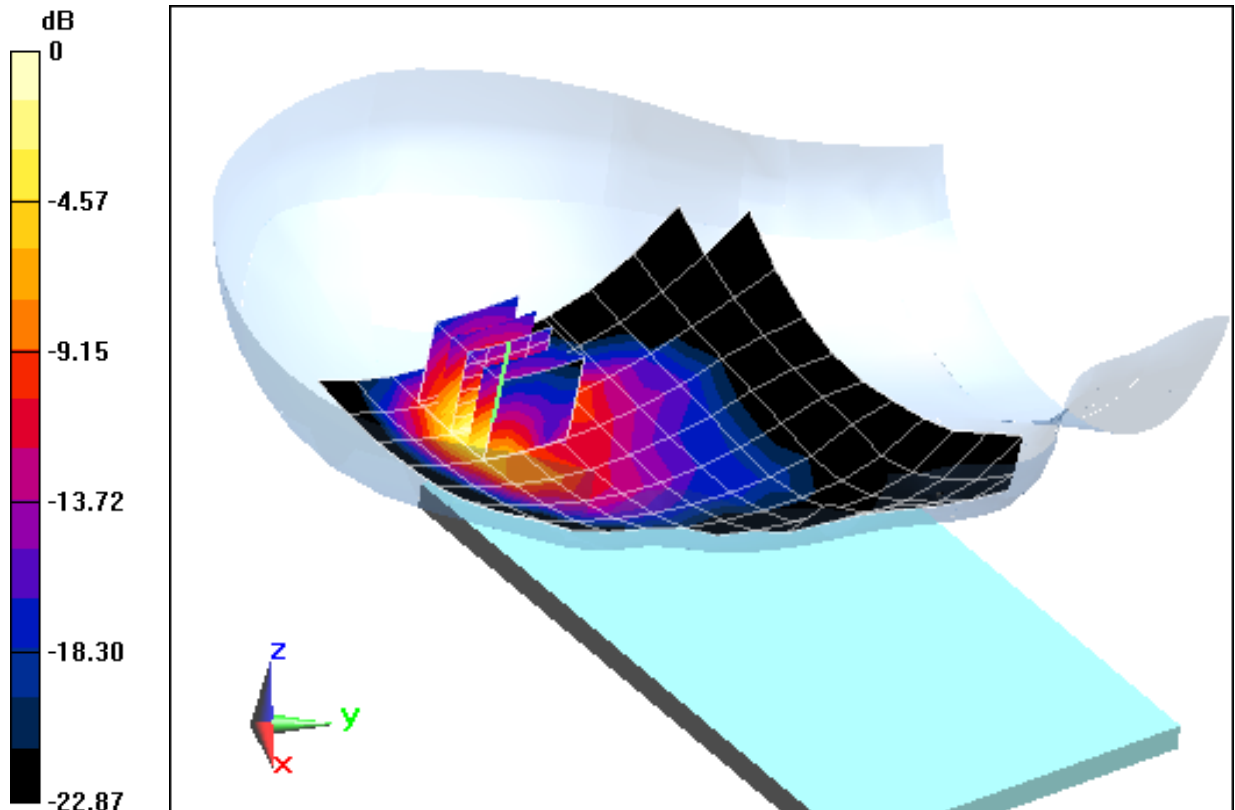

0 dB = 0.473 W/kg = -3.25 dBW/kg

# PCTEST ENGINEERING LABORATORY, INC.

**DUT: A3LSMT331; Type: Portable Tablet; Serial: 000323/8**

Communication System: UID 0, IEEE 802.11b; Frequency: 2462 MHz; Duty Cycle: 1:1  
Medium: 2450 Head; Medium parameters used (interpolated):  
 $f = 2462 \text{ MHz}$ ;  $\sigma = 1.891 \text{ S/m}$ ;  $\epsilon_r = 39.081$ ;  $\rho = 1000 \text{ kg/m}^3$

Phantom section: Left Section

Test Date: 01-06-2014; Ambient Temp: 19.8°C; Tissue Temp: 20.4°C

Probe: ES3DV3 - SN3263; ConvF(4.47, 4.47, 4.47); Calibrated: 5/16/2013;  
Sensor-Surface: 3mm (Mechanical Surface Detection)  
Electronics: DAE4 Sn859; Calibrated: 5/13/2013  
Phantom: SAM Main; Type: SAM 4.0; Serial: TP-1406

Measurement SW: DASY4, Version 4.7 (80); SEMCAD X Version 14.6.10 (7164)

**Mode: IEEE 802.11b, Left Head, Tilt, Ch 11, 1 Mbps**

**Area Scan (11x19x1):** Measurement grid: dx=12mm, dy=12mm

**Zoom Scan (7x7x7)/Cube 0:** Measurement grid: dx=5mm, dy=5mm, dz=5mm

Reference Value = 5.013 V/m; Power Drift = 0.03 dB

Peak SAR (extrapolated) = 0.0850 W/kg

**SAR(1 g) = 0.043 W/kg**

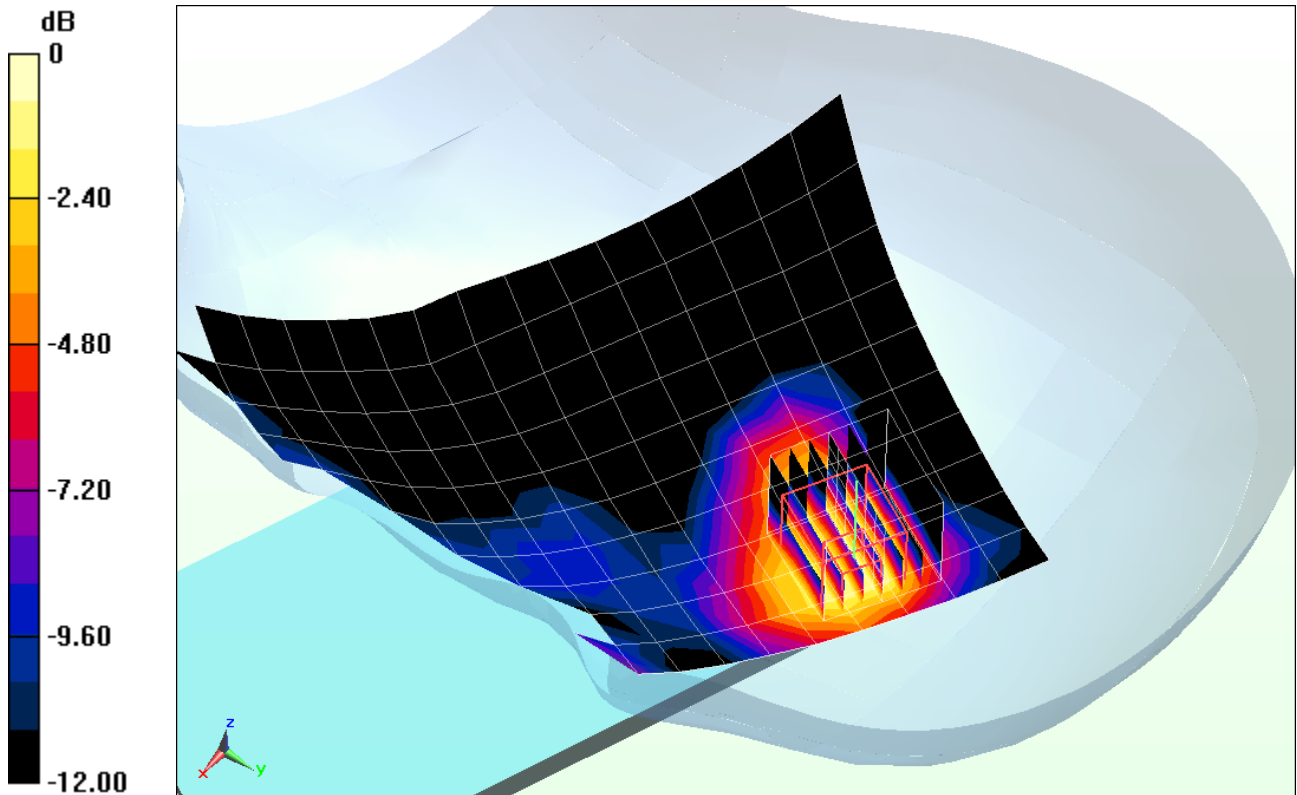

0 dB = 0.0543 W/kg = -12.65 dBW/kg

# PCTEST ENGINEERING LABORATORY, INC.

**DUT: A3LSMT331; Type: Portable Tablet; Serial: 000323/8**

Communication System: UID 0, IEEE 802.11a; Frequency: 5825 MHz; Duty Cycle: 1:1  
Medium: 5 GHz Head; Medium parameters used:

$$f = 5825 \text{ MHz}; \sigma = 5.135 \text{ S/m}; \epsilon_r = 35.915; \rho = 1000 \text{ kg/m}^3$$

Phantom section: Left Section

Test Date: 01-10-2014; Ambient Temp: 24.0°C; Tissue Temp: 23.3°C

Probe: EX3DV4 - SN3914; ConvF(4.52, 4.52, 4.52); Calibrated: 10/23/2013;

Sensor-Surface: 1.4mm (Mechanical Surface Detection)

Electronics: DAE4 Sn1333; Calibrated: 11/19/2013

Phantom: SAM V5.0 Right; Type: QD000P40CD; Serial: 1647

Measurement SW: DASY52, Version 52.8 (7); SEMCAD X Version 14.6.10 (7164)

**Mode: IEEE 802.11a, 5.8 GHz, Left Head, Tilt, Ch 165, 6 Mbps**

**Area Scan (13x22x1):** Measurement grid: dx=10mm, dy=10mm

**Zoom Scan (7x7x7)/Cube 0:** Measurement grid: dx=4mm, dy=4mm, dz=1.4mm; Graded Ratio: 1.4

Reference Value = 1.372 V/m; Power Drift = 0.04 dB

Peak SAR (extrapolated) = 0.208 W/kg

**SAR(1 g) = 0.013 W/kg**

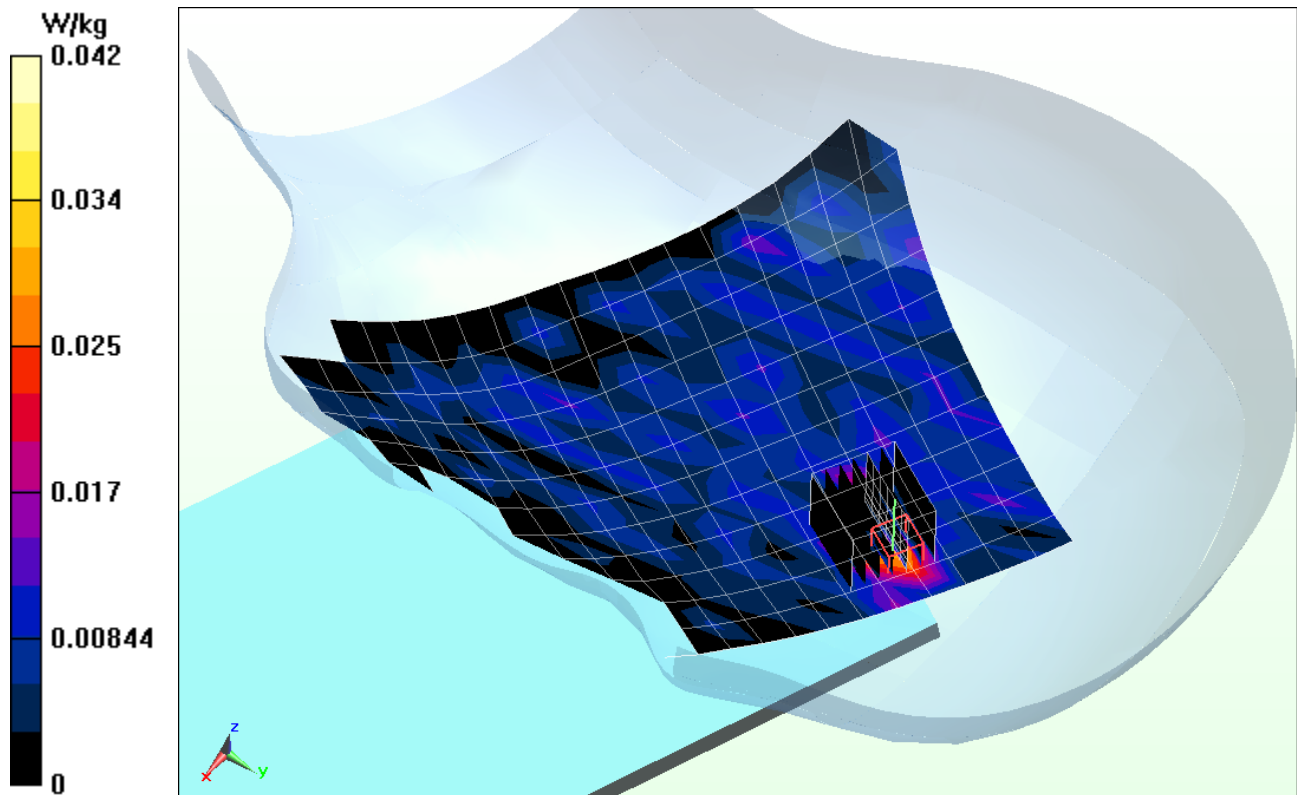

# PCTEST ENGINEERING LABORATORY, INC.

**DUT: A3LSMT331; Type: Portable Tablet; Serial: 000323/8**

Communication System: UID 0, IEEE 802.11a; Frequency: 5580 MHz; Duty Cycle: 1:1  
Medium: 5 GHz Head; Medium parameters used:

$$f = 5580 \text{ MHz}; \sigma = 4.867 \text{ S/m}; \epsilon_r = 36.212; \rho = 1000 \text{ kg/m}^3$$

Phantom section: Left Section

Test Date: 01-10-2014; Ambient Temp: 24.1°C; Tissue Temp: 23.1°C

Probe: EX3DV4 - SN3914; ConvF(4.37, 4.37, 4.37); Calibrated: 10/23/2013;

Sensor-Surface: 1.4mm (Mechanical Surface Detection)

Electronics: DAE4 Sn1333; Calibrated: 11/19/2013

Phantom: SAM V5.0 Right; Type: QD000P40CD; Serial: 1647

Measurement SW: DASY52, Version 52.8 (7);SEMCAD X Version 14.6.10 (7164)

**Mode: IEEE 802.11a, 5.5 - 5.7 GHz, Left Head, Tilt, Ch 116, 6 Mbps**

**Area Scan (13x22x1):** Measurement grid: dx=10mm, dy=10mm

**Zoom Scan (7x7x7)/Cube 0:** Measurement grid:dx=4mm,dy=4mm,dz=1.4mm;Graded Ratio:1.4

Reference Value = 1.459 V/m; Power Drift = -0.01 dB

Peak SAR (extrapolated) = 0.0980 W/kg

**SAR(1 g) = 0.014 W/kg**

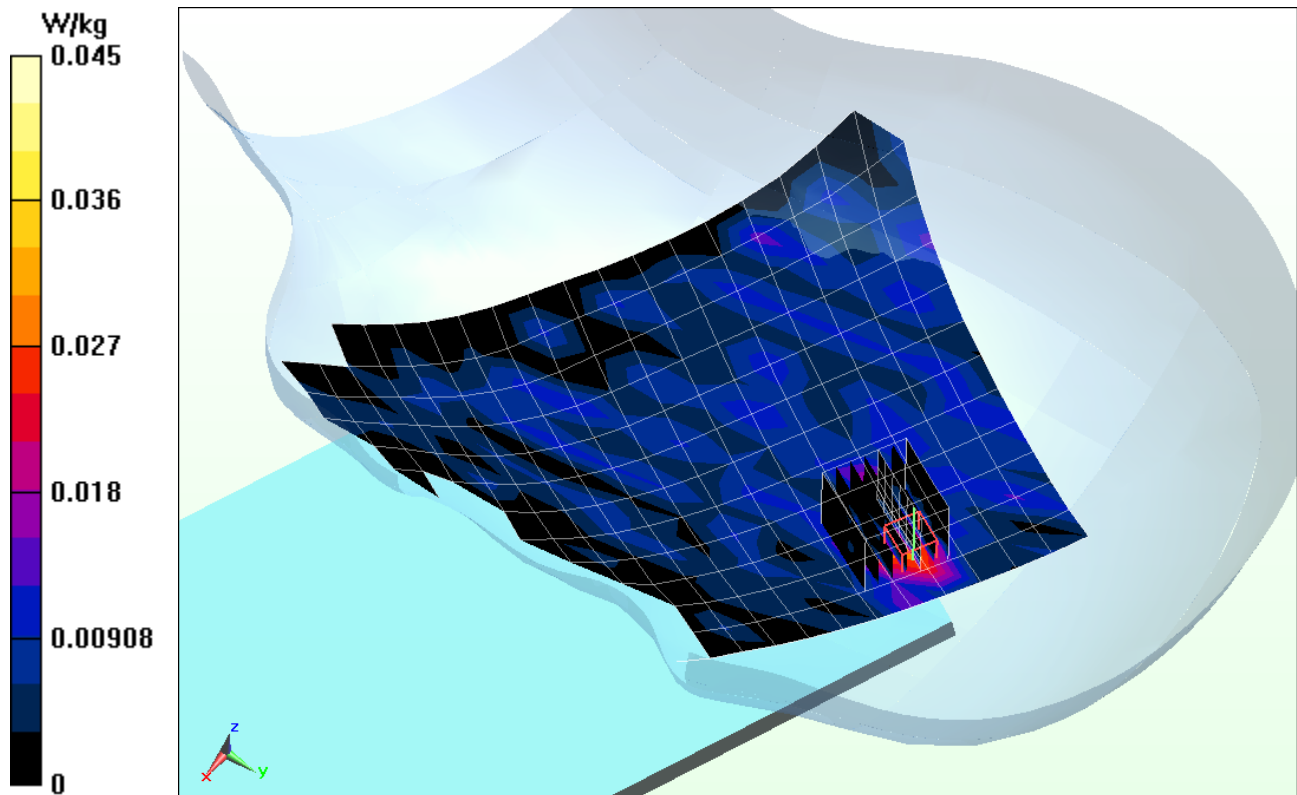

# PCTEST ENGINEERING LABORATORY, INC.

**DUT: A3LSMT331; Type: Portable Tablet; Serial: PCT03**

Communication System: UID 0, GSM GPRS; 3 Tx slots; Frequency: 824.2 MHz; Duty Cycle: 1:2.76

Medium: 835 Body Medium parameters used (interpolated):

$f = 824.2 \text{ MHz}$ ;  $\sigma = 0.993 \text{ S/m}$ ;  $\epsilon_r = 54.143$ ;  $\rho = 1000 \text{ kg/m}^3$

Phantom section: Flat Section; Space: 0 mm

Test Date: 01-08-2014; Ambient Temp: 24.2°C; Tissue Temp: 21.5°C

Probe: ES3DV3 - SN3333; ConvF(6.07, 6.07, 6.07); Calibrated: 11/22/2013;

Sensor-Surface: 4mm (Mechanical Surface Detection)

Electronics: DAE4 Sn1408; Calibrated: 11/19/2013

Phantom: ELI v5.0; Type: QDOVA001BB; Serial: 1229

Measurement SW: DASY52, Version 52.8 (7); SEMCAD X Version 14.6.10 (7164)

**Mode: GPRS 850, Body SAR, Back side, Low ch, 3 Tx Slots**

**Area Scan (11x17x1):** Measurement grid: dx=15mm, dy=15mm

**Zoom Scan (5x5x7)/Cube 0:** Measurement grid: dx=8mm, dy=8mm, dz=5mm

Reference Value = 33.065 V/m; Power Drift = 0.00 dB

Peak SAR (extrapolated) = 1.82 W/kg

**SAR(1 g) = 0.909 W/kg**

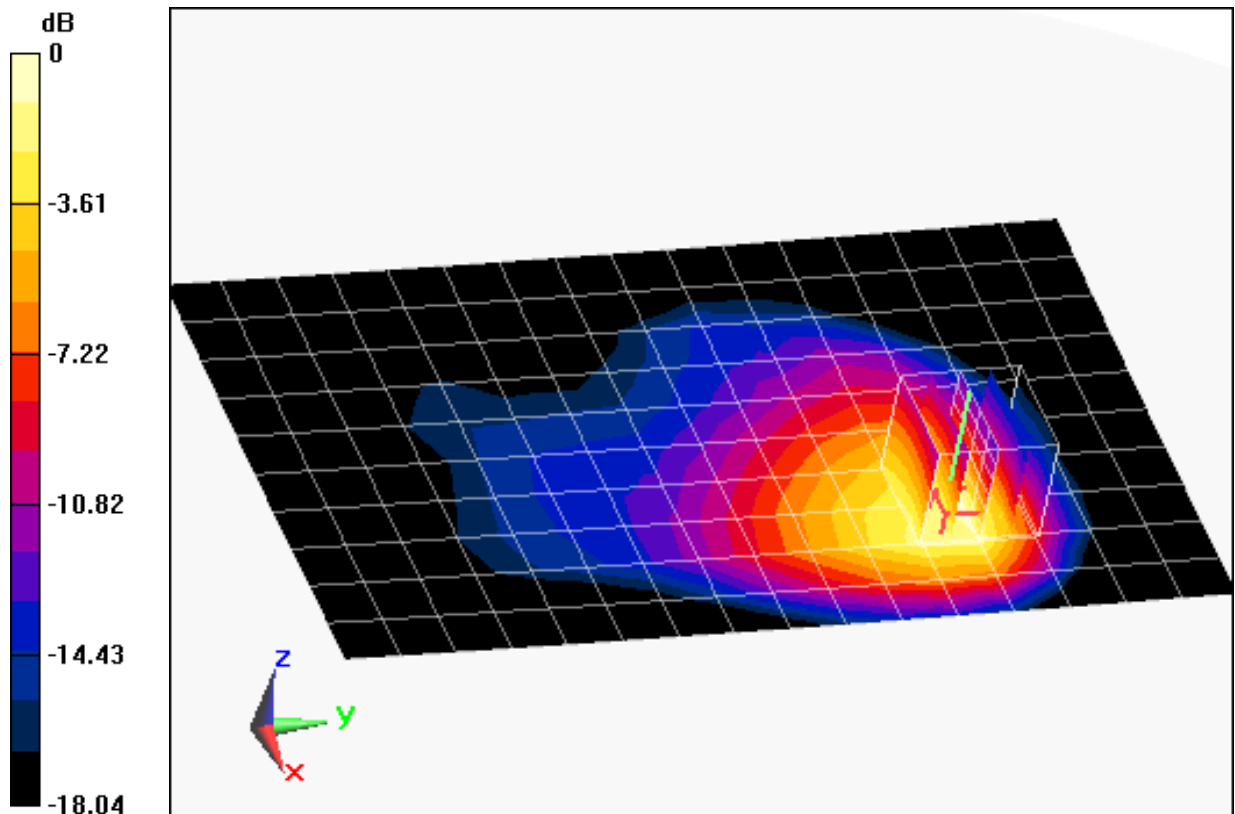

0 dB = 1.09 W/kg = 0.37 dBW/kg

# PCTEST ENGINEERING LABORATORY, INC.

**DUT: A3LSMT331; Type: Portable Tablet; Serial: PCT04**

Communication System: UID 0, GSM1900 GPRS; 3 Tx slots; Frequency: 1880 MHz; Duty Cycle: 1:2.76

Medium: 1900 Body Medium parameters used:

$f = 1880 \text{ MHz}$ ;  $\sigma = 1.557 \text{ S/m}$ ;  $\epsilon_r = 51.363$ ;  $\rho = 1000 \text{ kg/m}^3$

Phantom section: Flat Section; Space: 9 mm

Test Date: 01-13-2014; Ambient Temp: 23.6°C; Tissue Temp: 20.8°C

Probe: ES3DV3 - SN3319; ConvF(4.85, 4.85, 4.85); Calibrated: 4/29/2013;

Sensor-Surface: 4mm (Mechanical Surface Detection)

Electronics: DAE4 Sn1368; Calibrated: 4/22/2013

Phantom: SAM front; Type: QD000P40CD; Serial: TP:1759

Measurement SW: DASY52, Version 52.8 (7); SEMCAD X Version 14.6.10 (7164)

**Mode: GPRS 1900, Body SAR, Top Edge, Mid.ch, 3 Tx Slots**

**Area Scan (11x12x1):** Measurement grid: dx=5mm, dy=15mm

**Zoom Scan (5x5x7)/Cube 0:** Measurement grid: dx=8mm, dy=8mm, dz=5mm

Reference Value = 19.084 V/m; Power Drift = -0.04 dB

Peak SAR (extrapolated) = 0.803 W/kg

**SAR(1 g) = 0.482 W/kg**

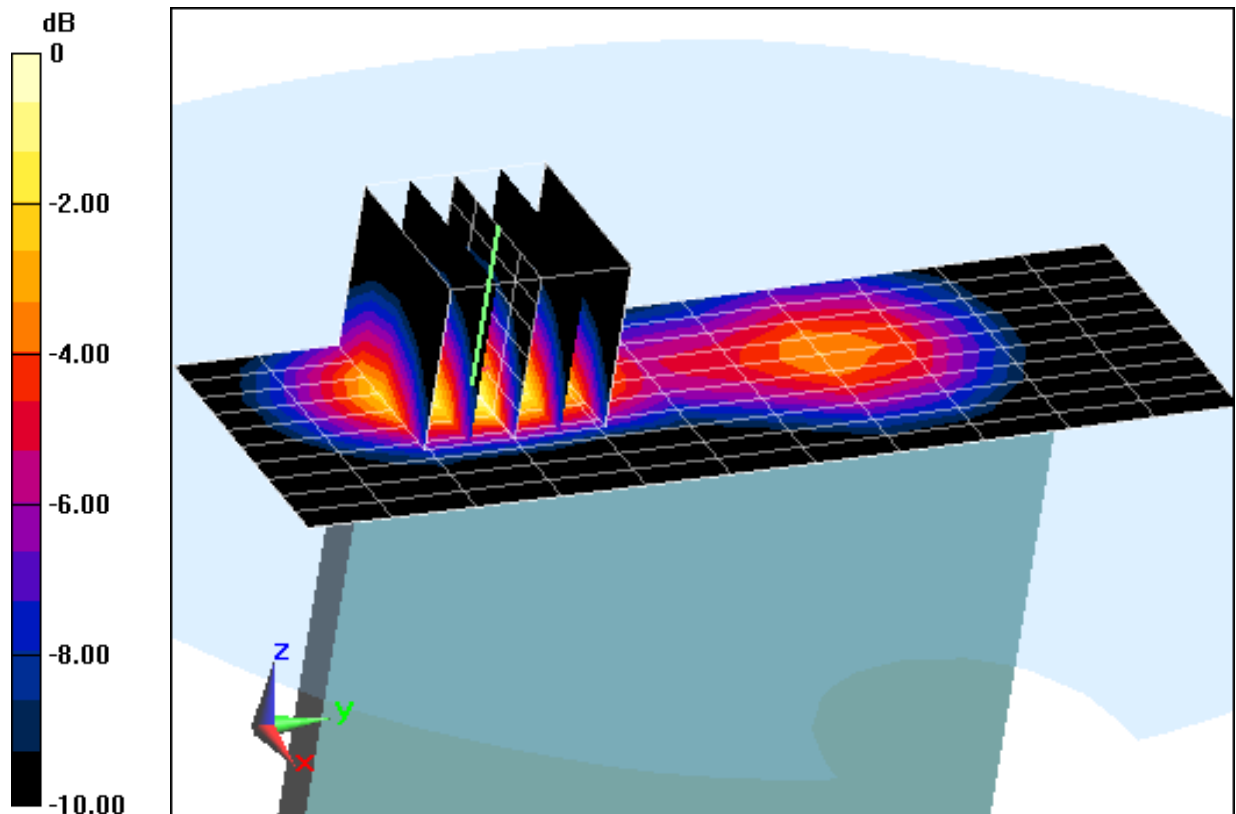

0 dB = 0.545 W/kg = -2.64 dBW/kg

# PCTEST ENGINEERING LABORATORY, INC.

**DUT: A3LSMT331; Type: Portable Tablet; Serial: 16-01-01**

Communication System: UID 0, UMTS; Frequency: 836.6 MHz; Duty Cycle: 1:1

Medium: 835 Body Medium parameters used (interpolated):

$f = 836.6 \text{ MHz}$ ;  $\sigma = 1.001 \text{ S/m}$ ;  $\epsilon_r = 53.519$ ;  $\rho = 1000 \text{ kg/m}^3$

Phantom section: Flat Section; Space: 12 mm

Test Date: 01-16-2014; Ambient Temp: 24.3°C; Tissue Temp: 22.3°C

Probe: ES3DV2 - SN3022; ConvF(5.91, 5.91, 5.91); Calibrated: 8/22/2013;

Sensor-Surface: 4mm (Mechanical Surface Detection)

Electronics: DAE4 Sn1322; Calibrated: 8/21/2013

Phantom: SAM v5.0 Left; Type: QD000P40CD; Serial: TP: 1687

Measurement SW: DASY52, Version 52.8 (7); SEMCAD X Version 14.6.10 (7164)

**Mode: UMTS 850, Body SAR, Back side, Mid.ch**

**Area Scan (13x19x1):** Measurement grid: dx=15mm, dy=15mm

**Zoom Scan (5x5x7)/Cube 0:** Measurement grid: dx=8mm, dy=8mm, dz=5mm

Reference Value = 21.728 V/m; Power Drift = -0.02 dB

Peak SAR (extrapolated) = 0.689 W/kg

**SAR(1 g) = 0.476 W/kg**

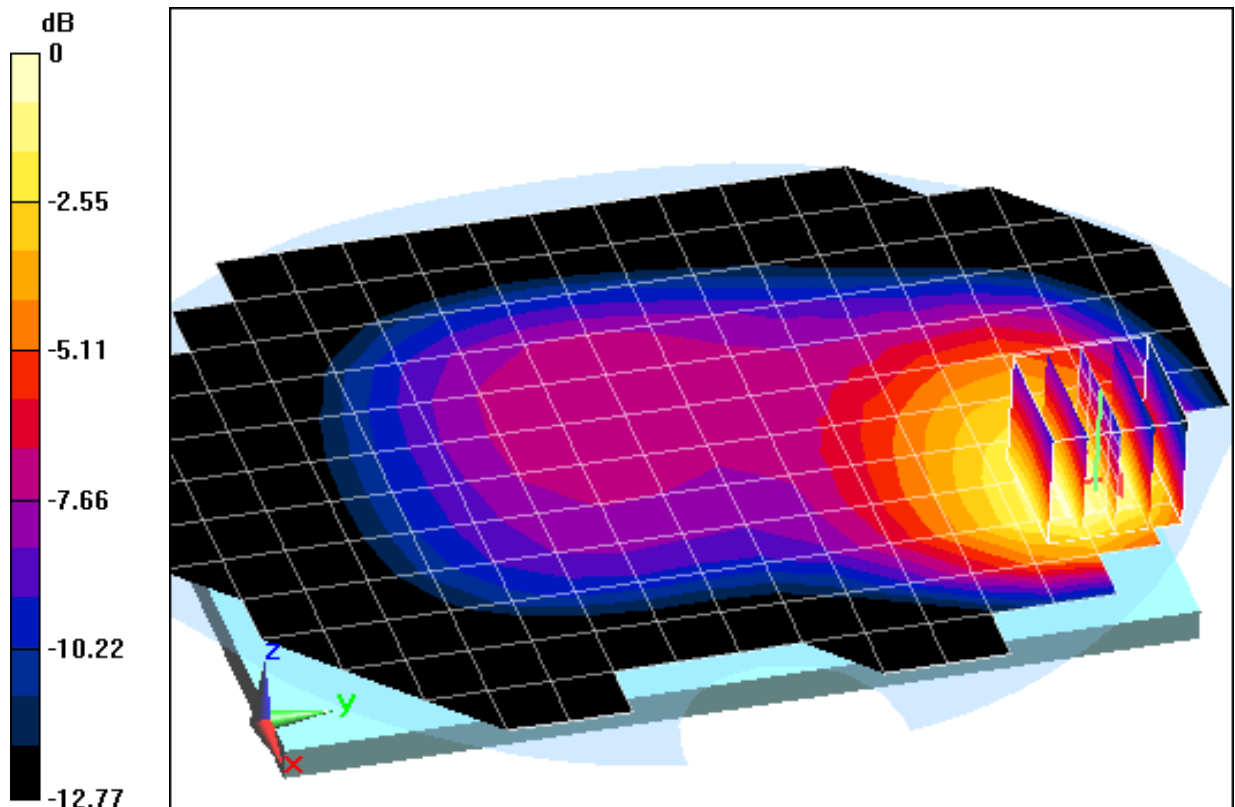

0 dB = 0.511 W/kg = -2.92 dBW/kg

# PCTEST ENGINEERING LABORATORY, INC.

**DUT: A3LSMT331; Type: Portable Tablet; Serial: 16-01-01**

Communication System: UID 0, UMTS; Frequency: 1880 MHz; Duty Cycle: 1:1

Medium: 1900 Body Medium parameters used:

$f = 1880 \text{ MHz}$ ;  $\sigma = 1.557 \text{ S/m}$ ;  $\epsilon_r = 51.245$ ;  $\rho = 1000 \text{ kg/m}^3$

Phantom section: Flat Section; Space: 9 mm

Test Date: 01-16-2014; Ambient Temp: 23.8°C; Tissue Temp: 22.5°C

Probe: ES3DV3 - SN3333; ConvF(4.71, 4.71, 4.71); Calibrated: 11/22/2013;

Sensor-Surface: 4mm (Mechanical Surface Detection)

Electronics: DAE4 Sn1408; Calibrated: 11/19/2013

Phantom: ELI v5.0; Type: QDOVA001BB; Serial: 1229

Measurement SW: DASY52, Version 52.8 (7); SEMCAD X Version 14.6.10(7164)

**Mode: UMTS 1900, Body SAR, Top Edge, Mid.ch**

**Area Scan (11x12x1):** Measurement grid: dx=5mm, dy=15mm

**Zoom Scan (5x5x7)/Cube 0:** Measurement grid: dx=8mm, dy=8mm, dz=5mm

Reference Value = 24.569 V/m; Power Drift = -0.02 dB

Peak SAR (extrapolated) = 1.44 W/kg

**SAR(1 g) = 0.833 W/kg**

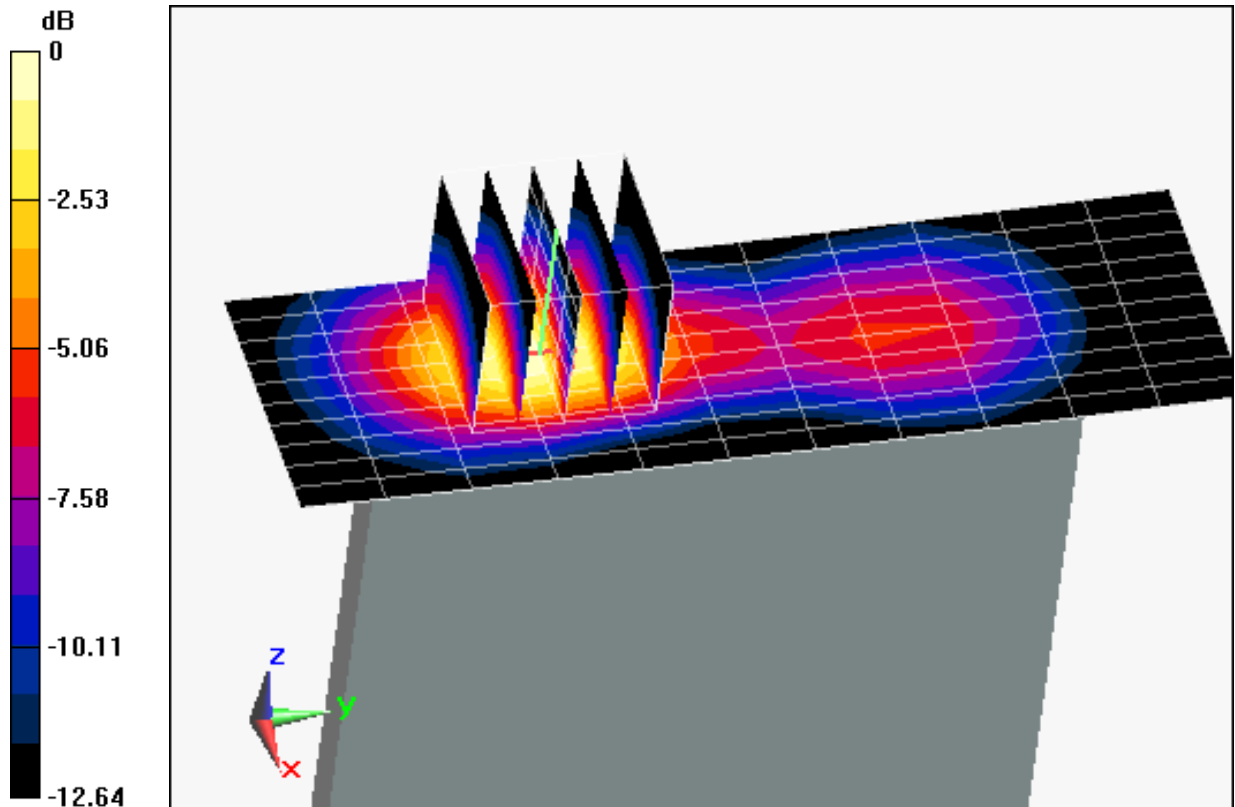

0 dB = 0.937 W/kg = -0.28 dBW/kg

# PCTEST ENGINEERING LABORATORY, INC.

**DUT: A3LSMT331; Type: Portable Tablet; Serial: 000410/3**

Communication System: UID 0, IEEE 802.11b; Frequency: 2462 MHz; Duty Cycle: 1:1

Medium: 2450 Body; Medium parameters used (interpolated):

$$f = 2462 \text{ MHz}; \sigma = 2.06 \text{ S/m}; \epsilon_r = 50.704; \rho = 1000 \text{ kg/m}^3$$

Phantom section: Flat Section; Space: 0.0 mm

Test Date: 01-17-2014; Ambient Temp: 21.9°C; Tissue Temp: 22.9°C

Probe: ES3DV3 - SN3209; ConvF(4.34, 4.34, 4.34); Calibrated: 3/15/2013;

Sensor-Surface: 3mm (Mechanical Surface Detection)

Electronics: DAE4 Sn1334; Calibrated: 3/8/2013

Phantom: ELI v5.0; Type: QDOVA002AA; Serial: TP-1158

Measurement SW: DASY52, Version 52.8 (7);SEMCAD X Version 14.6.10 (7164)

**Mode: IEEE 802.11b, Body SAR, Ch 11, 1 Mbps, Back Side**

**Area Scan (14x22x1):** Measurement grid: dx=12mm, dy=12mm

**Zoom Scan (7x7x7)/Cube 0:** Measurement grid: dx=5mm, dy=5mm, dz=5mm

Reference Value = 9.821 V/m; Power Drift = 0.19 dB

Peak SAR (extrapolated) = 0.837 W/kg

**SAR(1 g) = 0.266 W/kg**

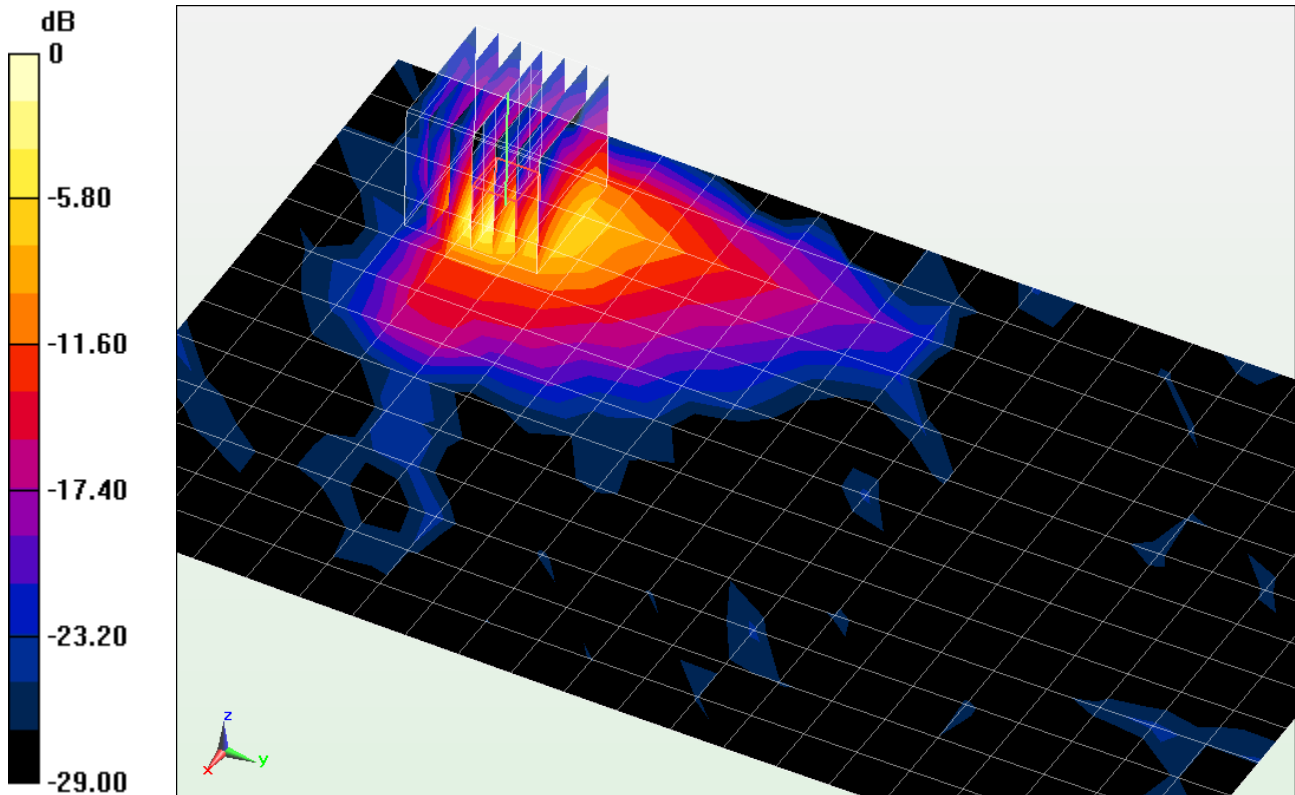

0 dB = 0.401 W/kg = -3.97 dBW/kg

# PCTEST ENGINEERING LABORATORY, INC.

**DUT: A3LSMT331; Type: Portable Tablet; Serial: 000815/3**

Communication System: UID 0, IEEE 802.11a; Frequency: 5765 MHz; Duty Cycle: 1:1

Medium: 5 GHz Body; Medium parameters used:

$$f = 5765 \text{ MHz}; \sigma = 6.202 \text{ S/m}; \epsilon_r = 46.361; \rho = 1000 \text{ kg/m}^3$$

Phantom section: Flat Section; Space: 0.0 mm

Test Date: 01-23-2014; Ambient Temp: 24.4°C; Tissue Temp: 22.3°C

Probe: EX3DV4 - SN3914; ConvF(4.14, 4.14, 4.14); Calibrated: 10/23/2013;

Sensor-Surface: 1.4mm (Mechanical Surface Detection)

Electronics: DAE4 Sn1333; Calibrated: 11/19/2013

Phantom: SAM V5.0 Right; Type: QD000P40CD; Serial: 1647

Measurement SW: DASY52, Version 52.8 (7); SEMCAD X Version 14.6.10 (7164)

**Mode: IEEE 802.11a, 5.8 GHz, Body SAR, Ch 153, 6 Mbps, Back Side**

**Area Scan (17x25x1):** Measurement grid: dx=10mm, dy=10mm

**Zoom Scan (8x8x7)/Cube 0:** Measurement grid: dx=4mm, dy=4mm, dz=1.4mm; Graded Ratio: 1.4

Reference Value = 8.970 V/m; Power Drift = 0.07 dB

Peak SAR (extrapolated) = 2.76 W/kg

**SAR(1 g) = 0.486 W/kg**

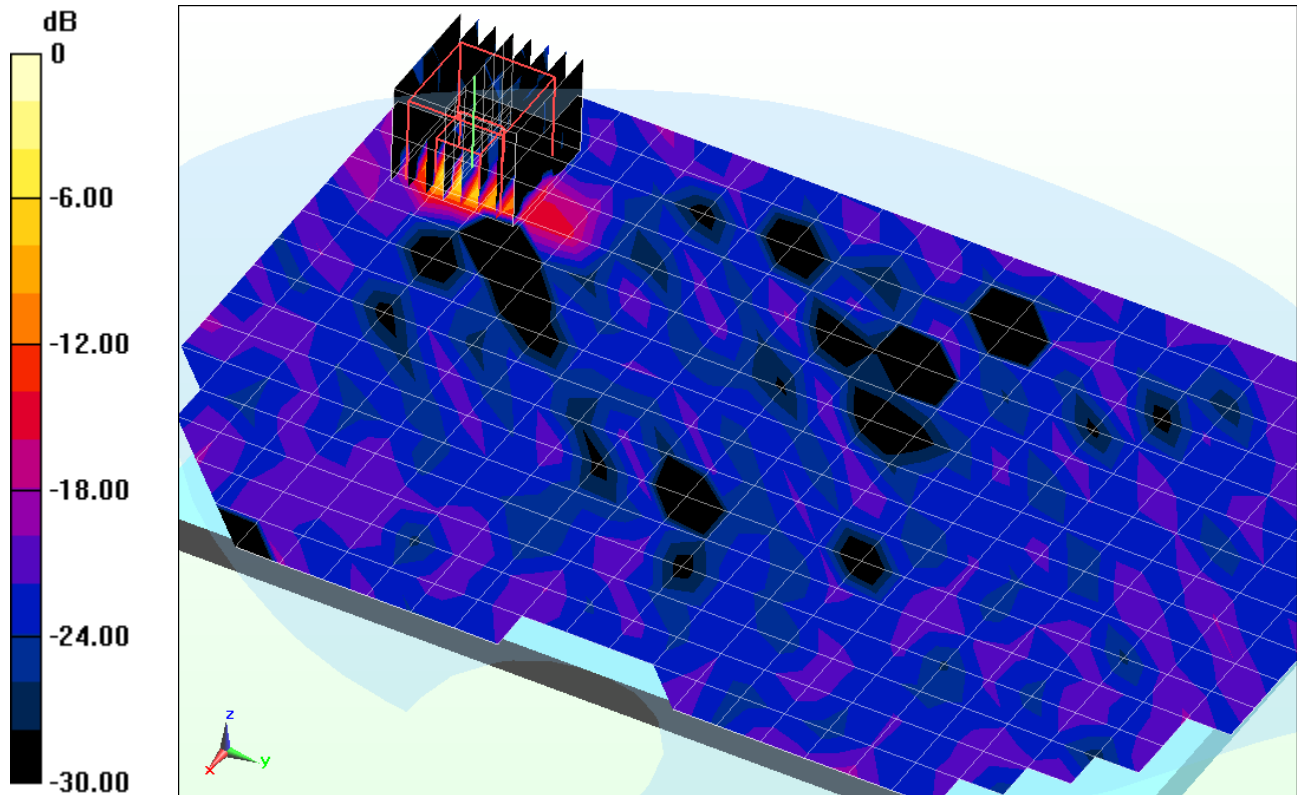

0 dB = 1.33 W/kg = 1.24 dBW/kg

# PCTEST ENGINEERING LABORATORY, INC.

**DUT: A3LSMT331; Type: Portable Tablet; Serial: 000815/3**

Communication System: UID 0, IEEE 802.11a; Frequency: 5300 MHz; Duty Cycle: 1:1  
Medium: 5 GHz Body; Medium parameters used:

$$f = 5300 \text{ MHz}; \sigma = 5.47 \text{ S/m}; \epsilon_r = 47.466; \rho = 1000 \text{ kg/m}^3$$

Phantom section: Flat Section; Space: 0.0 mm

Test Date: 01-23-2014; Ambient Temp: 23.8°C; Tissue Temp: 22.2°C

Probe: EX3DV4 - SN3914; ConvF(4.32, 4.32, 4.32); Calibrated: 10/23/2013;

Sensor-Surface: 1.4mm (Mechanical Surface Detection)

Electronics: DAE4 Sn1333; Calibrated: 11/19/2013

Phantom: SAM V5.0 Right; Type: QD000P40CD; Serial: 1647

Measurement SW: DASY52, Version 52.8 (7); SEMCAD X Version 14.6.10 (7164)

**Mode: IEEE 802.11a, 5.3 GHz, Body SAR, Ch 60, 6 Mbps, Back Side**

**Area Scan (17x25x1):** Measurement grid: dx=10mm, dy=10mm

**Zoom Scan (7x7x7)/Cube 0:** Measurement grid: dx=4mm, dy=4mm, dz=1.4mm; Graded Ratio: 1.4

Reference Value = 14.659 V/m; Power Drift = -0.01 dB

Peak SAR (extrapolated) = 5.63 W/kg

**SAR(1 g) = 0.948 W/kg**

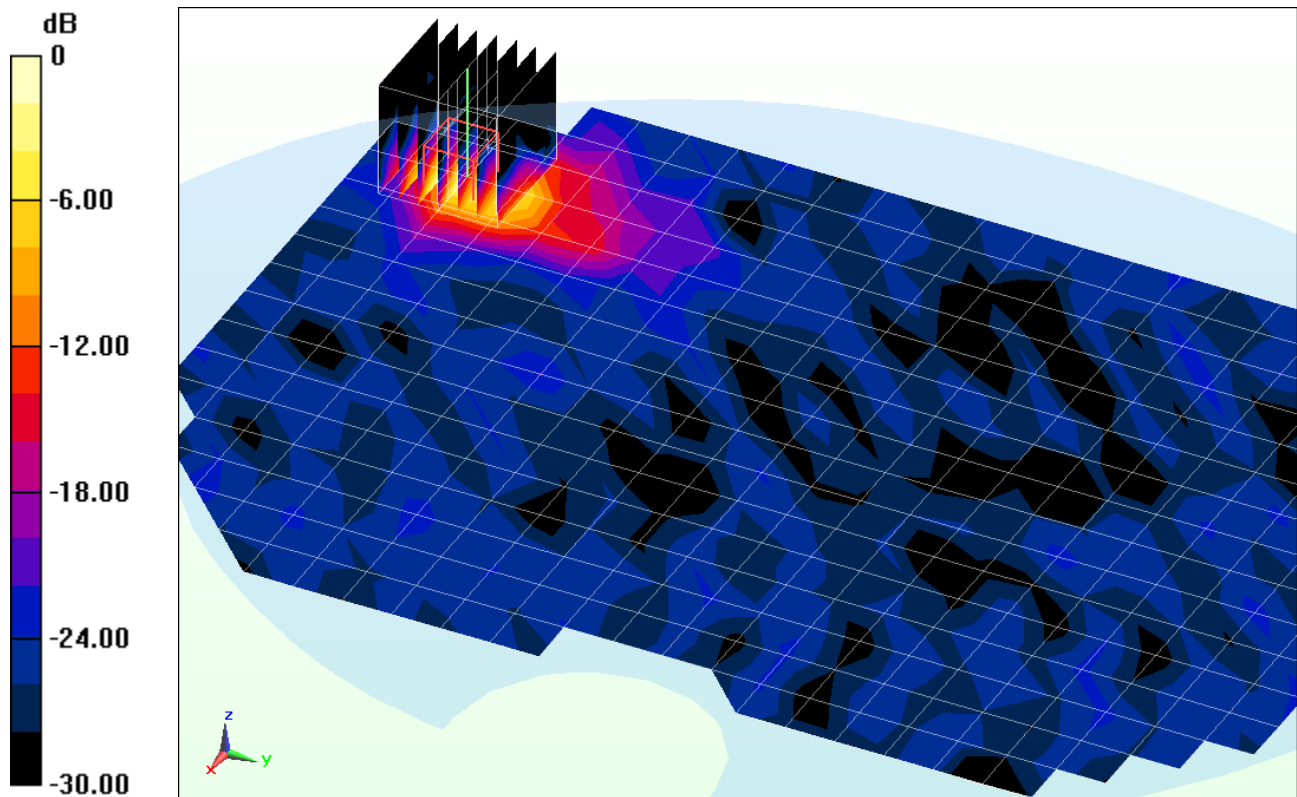

0 dB = 2.83 W/kg = 4.52 dBW/kg

# PCTEST ENGINEERING LABORATORY, INC.

**DUT: A3LSMT331; Type: Portable Tablet; Serial: 000815/3**

Communication System: UID 0, Bluetooth; Frequency: 2480 MHz; Duty Cycle: 1:1  
Medium: 2450 Body; Medium parameters used (interpolated):

$$f = 2480 \text{ MHz}; \sigma = 1.971 \text{ S/m}; \epsilon_r = 50.139; \rho = 1000 \text{ kg/m}^3$$

Phantom section: Flat Section; Space: 0.0 mm

Test Date: 01-24-2014; Ambient Temp: 23.5°C; Tissue Temp: 23.2°C

Probe: ES3DV3 - SN3333; ConvF(4.22, 4.22, 4.22); Calibrated: 11/22/2013;

Sensor-Surface: 3mm (Mechanical Surface Detection)

Electronics: DAE4 Sn1408; Calibrated: 11/19/2013

Phantom: SAM CRP v4.0; Type: QD000P40CD; Serial: TP:1797

Measurement SW: DASY52, Version 52.8 (7); SEMCAD X Version 14.6.10 (7164)

**Mode: Bluetooth, Body SAR, Ch 78, 1 Mbps, Back Side**

**Area Scan (13x21x1):** Measurement grid: dx=12mm, dy=12mm

**Zoom Scan (7x7x7)/Cube 0:** Measurement grid: dx=5mm, dy=5mm, dz=5mm

Reference Value = 6.259 V/m; Power Drift = 0.16 dB

Peak SAR (extrapolated) = 0.388 W/kg

**SAR(1 g) = 0.124 W/kg**

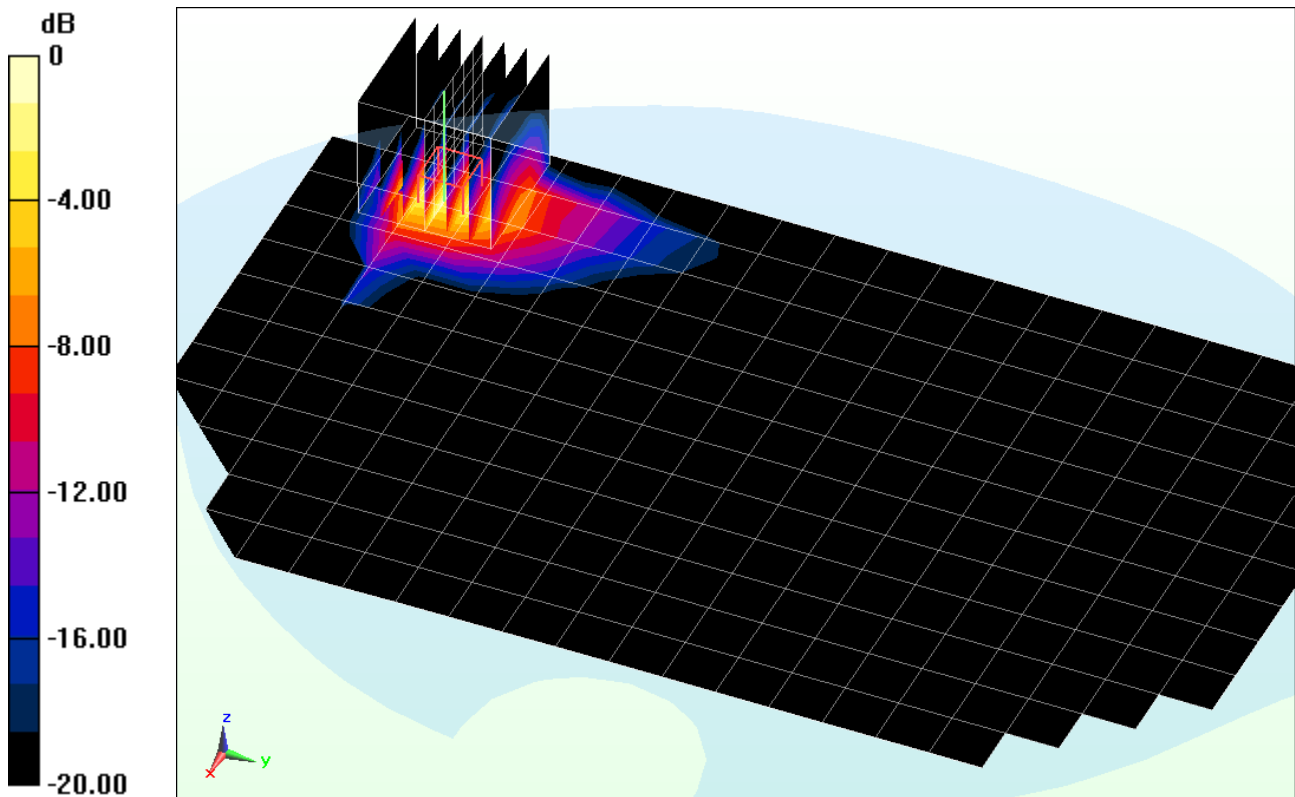

0 dB = 0.180 W/kg = -7.45 dBW/kg

## APPENDIX B: SYSTEM VERIFICATION

# PCTEST ENGINEERING LABORATORY, INC.

**DUT: Dipole 835 MHz; Type: D835V2; Serial: 4d119**

Communication System: UID 0, CW; Frequency: 835 MHz; Duty Cycle: 1:1

Medium: 835 Head Medium parameters used:

$f = 835 \text{ MHz}$ ;  $\sigma = 0.916 \text{ S/m}$ ;  $\epsilon_r = 40.979$ ;  $\rho = 1000 \text{ kg/m}^3$

Phantom section: Flat Section; Space: 1.5 cm

Test Date: 01-06-2014; Ambient Temp: 22.4°C; Tissue Temp: 22.2°C

Probe: ES3DV2 - SN3022; ConvF(6.09, 6.09, 6.09); Calibrated: 8/22/2013;

Sensor-Surface: 4mm (Mechanical Surface Detection)

Electronics: DAE4 Sn1322; Calibrated: 8/21/2013

Phantom: SAM v5.0 front; Type: QD000P40CD; Serial: TP-1646

Measurement SW: DASY52, Version 52.8 (7); SEMCAD X Version 14.6.10 (7164)

## 835 MHz System Verification

**Area Scan (7x14x1):** Measurement grid:  $dx=15\text{mm}$ ,  $dy=15\text{mm}$

**Zoom Scan (5x5x7)/Cube 0:** Measurement grid:  $dx=8\text{mm}$ ,  $dy=8\text{mm}$ ,  $dz=5\text{mm}$

Input Power: 20 dBm (100 mW)

Peak SAR (extrapolated) = 1.38 W/kg

**SAR(1 g) = 0.945 W/kg**

Deviation = -2.38%

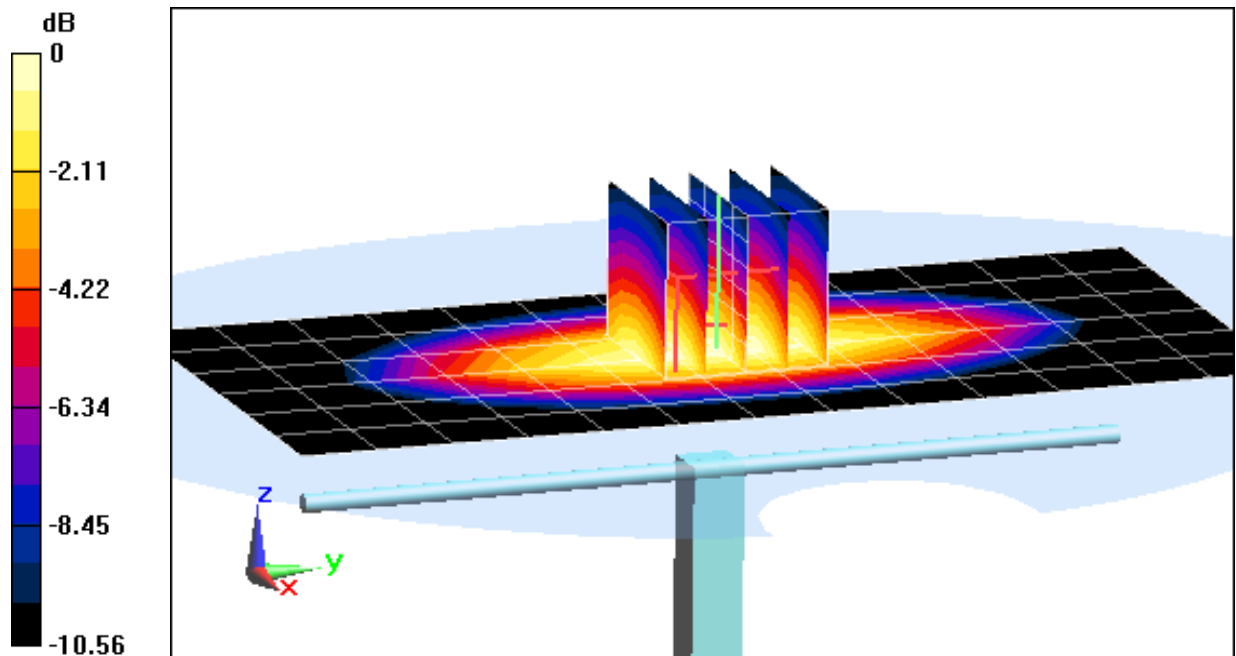

0 dB = 1.02 W/kg = 0.09 dBW/kg

# PCTEST ENGINEERING LABORATORY, INC.

**DUT: Dipole 1900 MHz; Type: D1900V2; Serial: 5d148**

Communication System: UID 0, CW; Frequency: 1900 MHz; Duty Cycle: 1:1

Medium: 1900 Head Medium parameters used (interpolated):

$f = 1900 \text{ MHz}$ ;  $\sigma = 1.438 \text{ S/m}$ ;  $\epsilon_r = 39.149$ ;  $\rho = 1000 \text{ kg/m}^3$

Phantom section: Flat Section; Space: 1.0 cm

Test Date: 01-08-2014; Ambient Temp: 23.9°C; Tissue Temp: 21.1°C

Probe: ES3DV3 - SN3209; ConvF(5.21, 5.21, 5.21); Calibrated: 3/15/2013;

Sensor-Surface: 4mm (Mechanical Surface Detection)

Electronics: DAE4 Sn1334; Calibrated: 3/8/2013

Phantom: SAM Front; Type: SAM; Serial: 1686

Measurement SW: DASY52, Version 52.8 (7); SEMCAD X Version 14.6.10 (7164)

## 1900 MHz System Verification

**Area Scan (7x10x1):** Measurement grid: dx=15mm, dy=15mm

**Zoom Scan (5x5x7)/Cube 0:** Measurement grid: dx=8mm, dy=8mm, dz=5mm

Input Power: 20 dBm (100 mW)

Peak SAR (extrapolated) = 7.38 W/kg

**SAR(1 g) = 4 W/kg**

Deviation= 0.76%

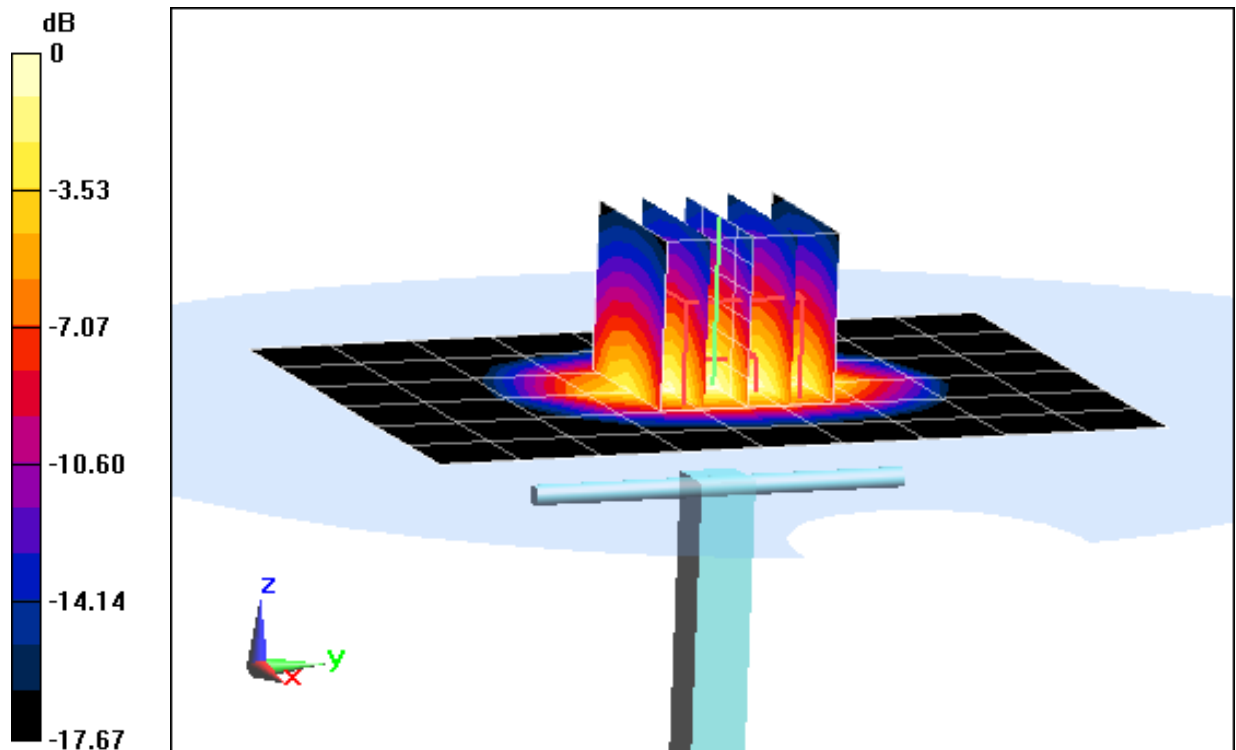

0 dB = 4.50 W/kg = 6.53 dBW/kg

# PCTEST ENGINEERING LABORATORY, INC.

**DUT: Dipole 2450 MHz; Type: D2450V2; Serial: 882**

Communication System: UID 0, CW; Frequency: 2450 MHz; Duty Cycle: 1:1

Medium: 2450 Head Medium parameters used:

$f = 2450 \text{ MHz}$ ;  $\sigma = 1.877 \text{ S/m}$ ;  $\epsilon_r = 39.133$ ;  $\rho = 1000 \text{ kg/m}^3$

Phantom section: Flat Section; Space: 1.0 cm

Test Date: 01-06-2014; Ambient Temp: 19.8°C; Tissue Temp: 20.4°C

Probe: ES3DV3 - SN3263; ConvF(4.47, 4.47, 4.47); Calibrated: 5/16/2013;

Sensor-Surface: 3mm (Mechanical Surface Detection)

Electronics: DAE4 Sn859; Calibrated: 5/13/2013

Phantom: SAM Main; Type: SAM 4.0; Serial: TP-1406

Measurement SW: DASY4, Version 4.7 (80); SEMCAD X Version 14.6.10 (7164)

## 2450MHz System Verification

**Area Scan (6x9x1):** Measurement grid: dx=12mm, dy=12mm

**Zoom Scan (7x7x7)/Cube 0:** Measurement grid: dx=5mm, dy=5mm, dz=5mm

Input Power: 20 dBm (100 mW)

Peak SAR (extrapolated) = 11.1 W/kg

**SAR(1 g) = 5.2 W/kg;**

Deviation= 0.58%

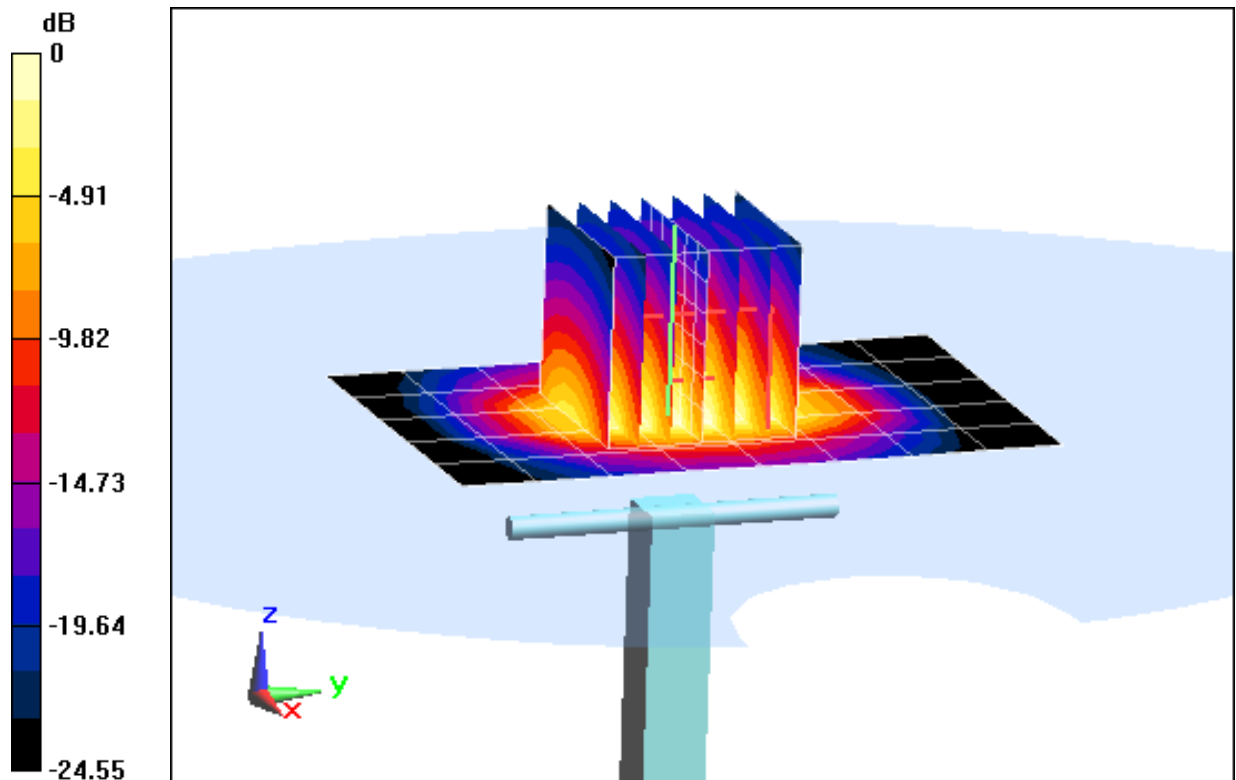

0 dB = 6.69 W/kg = 8.25 dBW/kg

# PCTEST ENGINEERING LABORATORY, INC.

**DUT: Dipole 5200 MHz; Type: D5GHzV2; Serial: 1120**

Communication System: UID 0, CW; Frequency: 5200 MHz; Duty Cycle: 1:1

Medium: 5 GHz Head Medium parameters used:

$f = 5200 \text{ MHz}$ ;  $\sigma = 4.494 \text{ S/m}$ ;  $\epsilon_r = 36.716$ ;  $\rho = 1000 \text{ kg/m}^3$

Phantom section: Flat Section; Space: 1.0 cm

Test Date: 01-10-2014; Ambient Temp: 24.1°C; Tissue Temp: 23.3°C

Probe: EX3DV4 - SN3914; ConvF(4.99, 4.99, 4.99); Calibrated: 10/23/2013;

Sensor-Surface: 1.4mm (Mechanical Surface Detection)

Electronics: DAE4 Sn1333; Calibrated: 11/19/2013

Phantom: SAM V5.0 Right; Type: QD000P40CD; Serial: 1647

Measurement SW: DASY52, Version 52.8 (7); SEMCAD X Version 14.6.10 (7164)

## 5200 MHz System Verification

**Area Scan (7x7x1):** Measurement grid: dx=10mm, dy=10mm

**Zoom Scan (7x7x7)/Cube 0:** Measurement grid: dx=4mm, dy=4mm, dz=1.4mm; Graded Ratio: 1.4

Input Power: 16 dBm (40 mW)

Peak SAR (extrapolated) = 12.5 W/kg

**SAR(1 g) = 3 W/kg**

Deviation= -1.32%

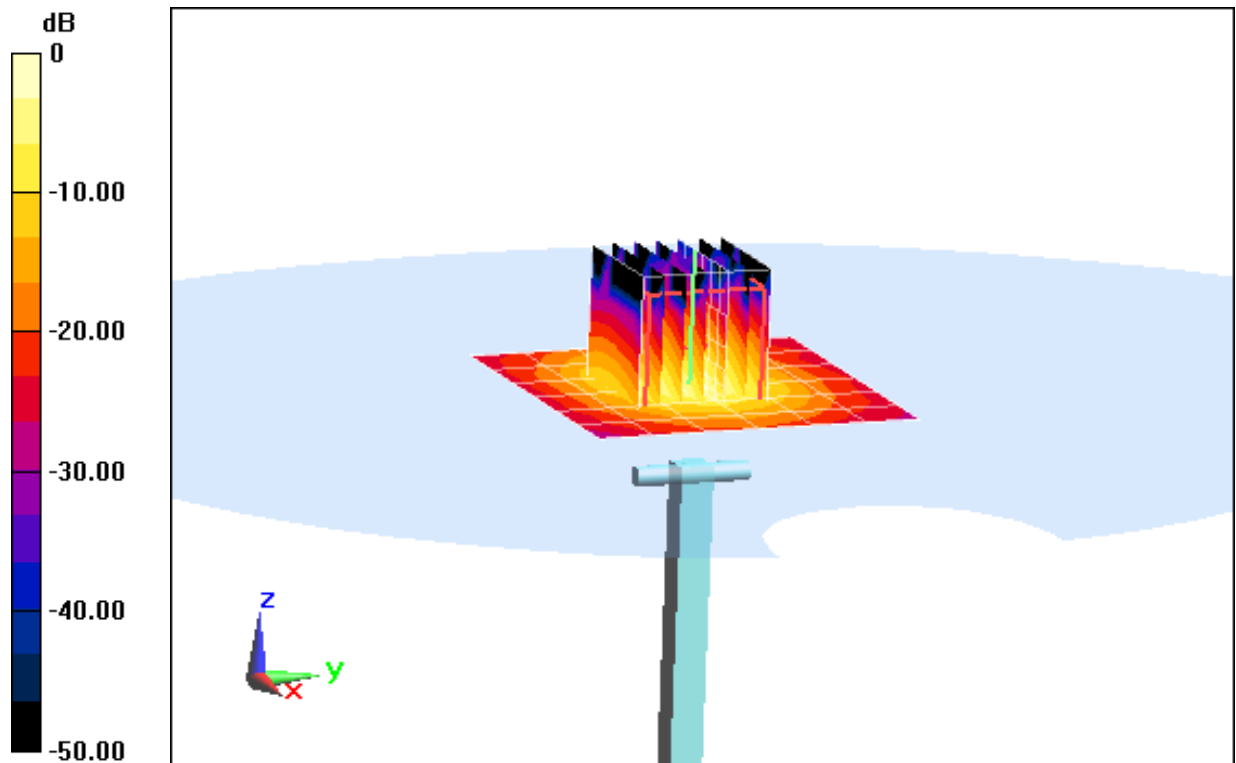

# PCTEST ENGINEERING LABORATORY, INC.

**DUT: Dipole 5300 MHz; Type: D5GHzV2; Serial: 1120**

Communication System: UID 0, CW; Frequency: 5300 MHz; Duty Cycle: 1:1

Medium: 5 GHz Head Medium parameters used:

$f = 5300 \text{ MHz}$ ;  $\sigma = 4.591 \text{ S/m}$ ;  $\epsilon_r = 36.609$ ;  $\rho = 1000 \text{ kg/m}^3$

Phantom section: Flat Section; Space: 1.0 cm

Test Date: 01-10-2014; Ambient Temp: 24.1°C; Tissue Temp: 23.1°C

Probe: EX3DV4 - SN3914; ConvF(4.82, 4.82, 4.82); Calibrated: 10/23/2013;

Sensor-Surface: 1.4 mm (Mechanical Surface Detection)

Electronics: DAE4 Sn1333; Calibrated: 11/19/2013

Phantom: SAM V5.0 Right; Type: QD000P40CD; Serial: 1647

Measurement SW: DASY52, Version 52.8 (7); SEMCAD X Version 14.6.10 (7164)

## 5300 MHz System Verification

**Area Scan (7x8x1):** Measurement grid: dx=10mm, dy=10mm

**Zoom Scan (7x7x7)/Cube 0:** Measurement grid: dx=4mm, dy=4mm, dz=1.4mm; Graded Ratio: 1.4

Input Power: 16 dBm (40 mW)

Peak SAR (extrapolated) = 13.2 W/kg

**SAR(1 g) = 3.12 W/kg**

Deviation= -0.89%

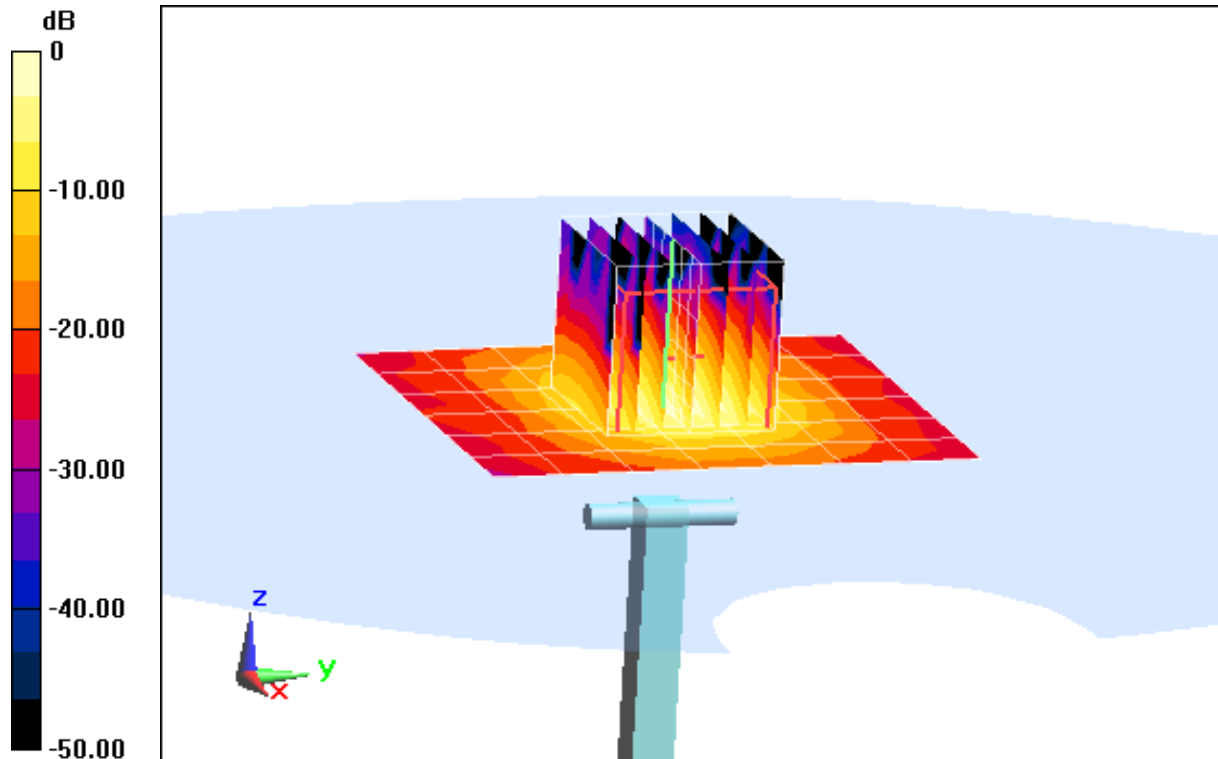

0 dB = 6.05 W/kg = 7.82 dBW/kg

# PCTEST ENGINEERING LABORATORY, INC.

**DUT: Dipole 5600 MHz; Type: D5GHzV2; Serial: 1120**

Communication System: UID 0, CW; Frequency: 5600 MHz; Duty Cycle: 1:1

Medium: 5 GHz Head Medium parameters used:

$f = 5600 \text{ MHz}$ ;  $\sigma = 4.909 \text{ S/m}$ ;  $\epsilon_r = 36.184$ ;  $\rho = 1000 \text{ kg/m}^3$

Phantom section: Flat Section; Space: 1.0 cm

Test Date: 1-10-2014; Ambient Temp: 24.1°C; Tissue Temp: 23.1°C

Probe: EX3DV4 - SN3914; ConvF(4.37, 4.37, 4.37); Calibrated: 10/23/2013;

Sensor-Surface: 1.4mm (Mechanical Surface Detection)

Electronics: DAE4 Sn1333; Calibrated: 11/19/2013

Phantom: SAM V5.0 Right; Type: QD000P40CD; Serial: 1647

Measurement SW: DASY52, Version 52.8 (7); SEMCAD X Version 14.6.10 (7164)

## 5600 MHz System Verification

**Area Scan (7x7x1):** Measurement grid: dx=10mm, dy=10mm

**Zoom Scan (7x7x7)/Cube 0:** Measurement grid: dx=4mm, dy=4mm, dz=1.4mm; Graded Ratio: 1.4

Input Power: 16 dBm (40 mW)

Peak SAR (extrapolated) = 14.7 W/kg

**SAR(1 g) = 3.27 W/kg**

Deviation= 2.32%

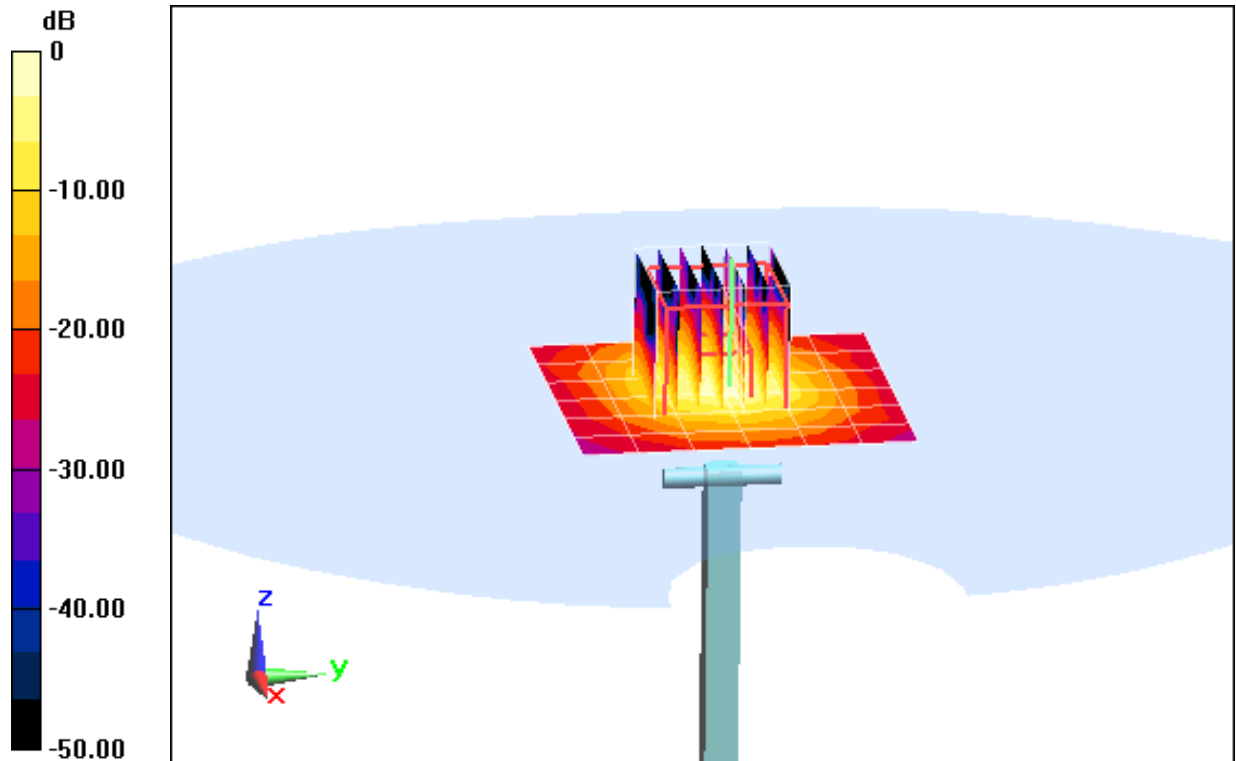

0 dB = 7.97 W/kg = 9.01 dBW/kg

# PCTEST ENGINEERING LABORATORY, INC.

**DUT: Dipole 5800 MHz; Type: D5GHzV2; Serial: 1120**

Communication System: UID 0; CW; Frequency: 5800 MHz; Duty Cycle: 1:1

Medium: 5 GHz Head Medium parameters used:

$f = 5800 \text{ MHz}$ ;  $\sigma = 5.11 \text{ S/m}$ ;  $\epsilon_r = 35.984$ ;  $\rho = 1000 \text{ kg/m}^3$

Phantom section: Flat Section; Space: 1.0 cm

Test Date: 01-10-2014; Ambient Temp: 24.0°C; Tissue Temp: 23.3°C

Probe: EX3DV4 - SN3914; ConvF(4.52, 4.52, 4.52); Calibrated: 10/23/2013;

Sensor-Surface: 1.4mm (Mechanical Surface Detection)

Electronics: DAE4 Sn1333; Calibrated: 11/19/2013

Phantom: SAM V5.0 Right; Type: QD000P40CD; Serial: 1647

Measurement SW: DASY52, Version 52.8 (7); SEMCAD X Version 14.6.10 (7164)

## 5800 MHz System Verification

**Area Scan (7x7x1):** Measurement grid: dx=10mm, dy=10mm

**Zoom Scan (7x7x7)/Cube 0:** Measurement grid: dx=4mm, dy=4mm, dz=1.4mm; Graded Ratio: 1.4

Input Power: 16 dBm (40 mW)

Peak SAR (extrapolated) = 14.4 W/kg

**SAR(1 g) = 3.02 W/kg;**

Deviation= 0.80%

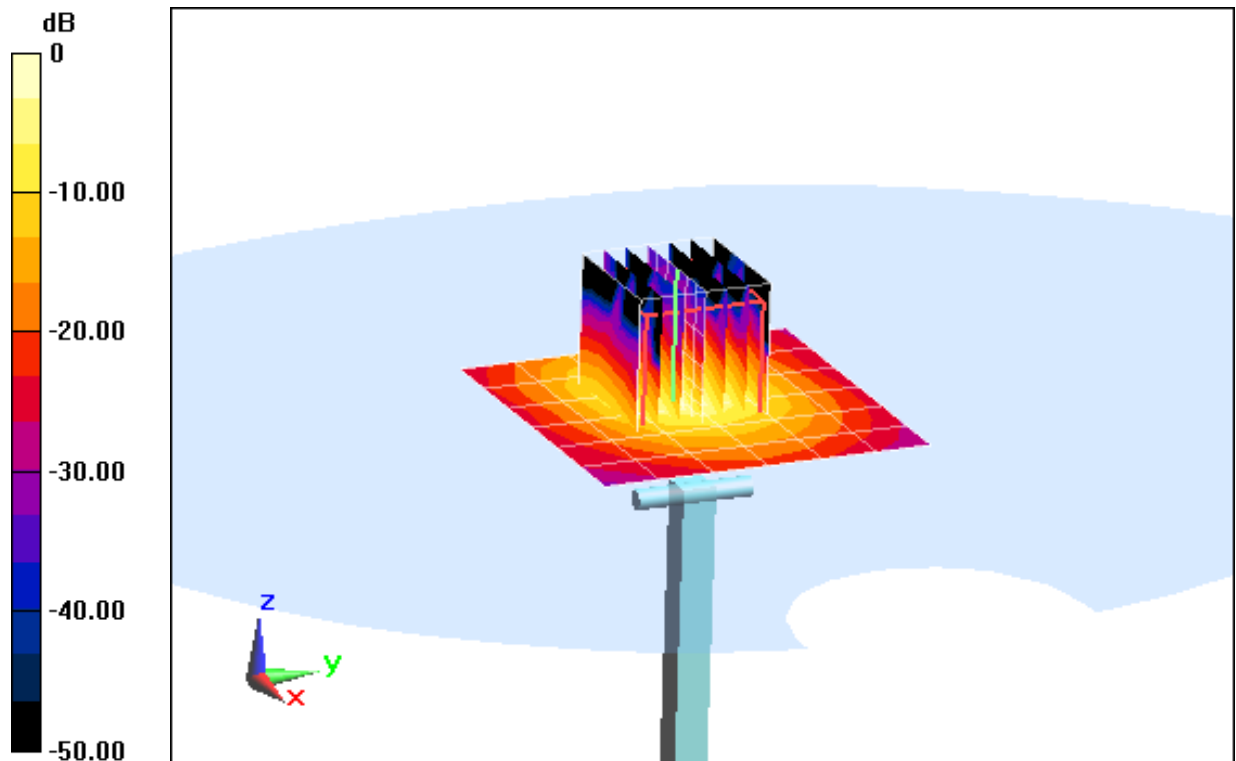

0 dB = 7.48 W/kg = 8.74 dBW/kg

# PCTEST ENGINEERING LABORATORY, INC.

**DUT: Dipole 835 MHz; Type: D835V2; Serial: 4d119**

Communication System: UID 0, CW; Frequency: 835 MHz; Duty Cycle: 1:1

Medium: 835 Body Medium parameters used:

$f = 835 \text{ MHz}$ ;  $\sigma = 1.003 \text{ S/m}$ ;  $\epsilon_r = 54.041$ ;  $\rho = 1000 \text{ kg/m}^3$

Phantom section: Flat Section; Space: 1.5 cm

Test Date: 01-08-2014; Ambient Temp: 24.2°C; Tissue Temp: 21.5°C

Probe: ES3DV3 - SN3333; ConvF(6.07, 6.07, 6.07); Calibrated: 11/22/2013;

Sensor-Surface: 4mm (Mechanical Surface Detection)

Electronics: DAE4 Sn1408; Calibrated: 11/19/2013

Phantom: ELI v5.0; Type: QDOVA001BB; Serial: 1229

Measurement SW: DASY52, Version 52.8 (7); SEMCAD X Version 14.6.10 (7164)

## 835 MHz System Verification

**Area Scan (7x14x1):** Measurement grid: dx=15mm, dy=15mm

**Zoom Scan (5x5x7)/Cube 0:** Measurement grid: dx=8mm, dy=8mm, dz=5mm

Input Power: 20 dBm (100 mW)

Peak SAR (extrapolated) = 1.38 W/kg

**SAR(1 g) = 0.939 W/kg**

Deviation = -1.57%

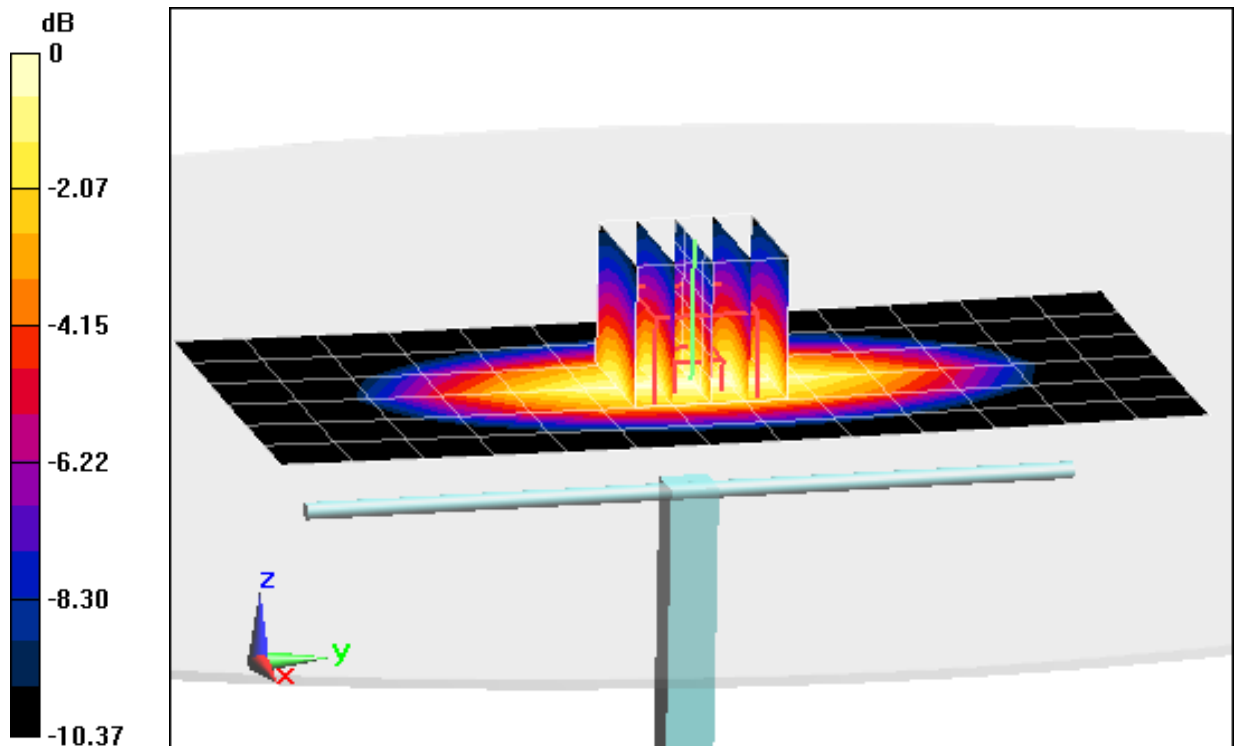

0 dB = 1.01 W/kg = 0.04 dBW/kg

# PCTEST ENGINEERING LABORATORY, INC.

**DUT: Dipole 835 MHz; Type: D835V2; Serial: 4d119**

Communication System: UID 0, CW; Frequency: 835 MHz; Duty Cycle: 1:1

Medium: 835 Body Medium parameters used:

$f = 835 \text{ MHz}$ ;  $\sigma = 0.999 \text{ S/m}$ ;  $\epsilon_r = 53.539$ ;  $\rho = 1000 \text{ kg/m}^3$

Phantom section: Flat Section; Space: 1.5 cm

Test Date: 01-16-2014; Ambient Temp: 24.3°C; Tissue Temp: 22.3°C

Probe: ES3DV2 - SN3022; ConvF(5.91, 5.91, 5.91); Calibrated: 8/22/2013;

Sensor-Surface: 4mm (Mechanical Surface Detection)

Electronics: DAE4 Sn1322; Calibrated: 8/21/2013

Phantom: SAM v5.0 Left; Type: QD000P40CD; Serial: TP: 1687

Measurement SW: DASY52, Version 52.8 (7); SEMCAD X Version 14.6.10 (7164)

## 835 MHz System Verification

**Area Scan (7x14x1):** Measurement grid: dx=15mm, dy=15mm

**Zoom Scan (5x5x7)/Cube 0:** Measurement grid: dx=8mm, dy=8mm, dz=5mm

Input Power: 20 dBm (100 mW)

Peak SAR (extrapolated) = 1.40 W/kg

**SAR(1 g) = 0.973 W/kg**

Deviation = 1.99%

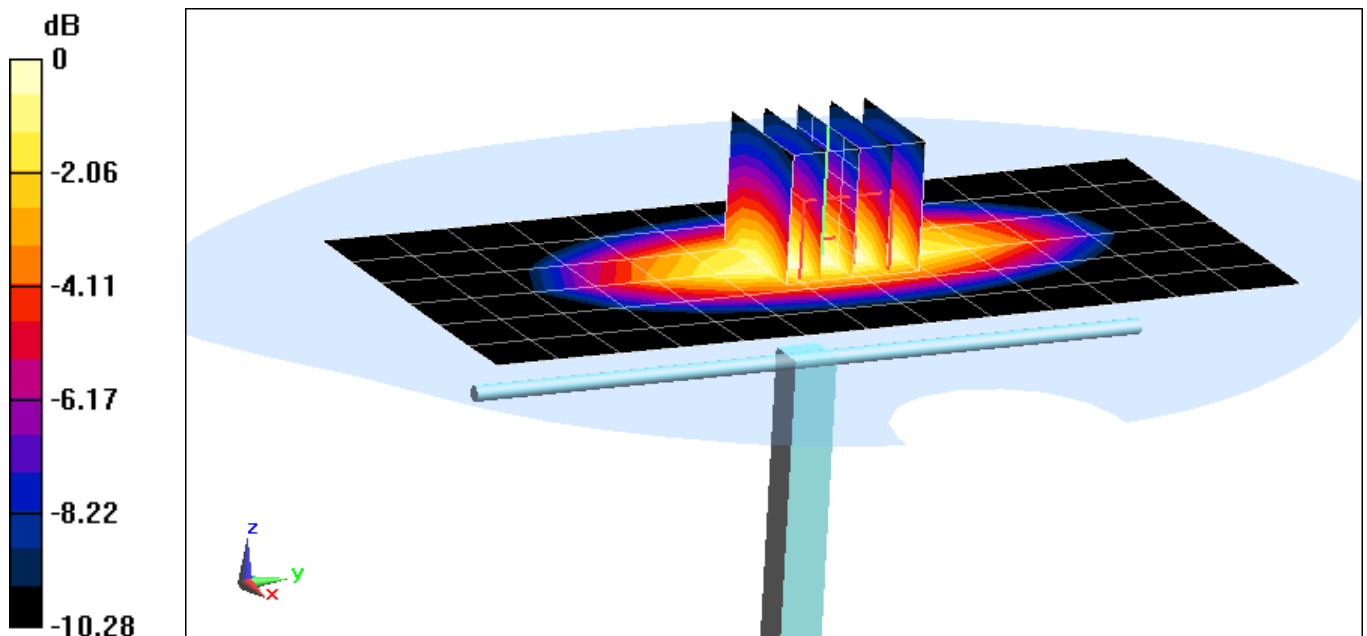

0 dB = 1.05 W/kg = 0.21 dBW/kg

# PCTEST ENGINEERING LABORATORY, INC.

**DUT:Dipole 1900 MHz; Type: D1900V2; Serial: 5d149**

Communication System: UID 0, CW; Frequency: 1900 MHz;Duty Cycle: 1:1

Medium: 1900 Body Medium parameters used (interpolated):

$f = 1900 \text{ MHz}$ ;  $\sigma = 1.578 \text{ S/m}$ ;  $\epsilon_r = 51.294$ ;  $\rho = 1000 \text{ kg/m}^3$

Phantom section: Flat Section; Space: 1.0 cm

Test Date: 01-13-2014; Ambient Temp: 23.6°C; Tissue Temp: 20.8°C

Probe: ES3DV3 - SN3319; ConvF(4.85, 4.85, 4.85); Calibrated: 4/29/2013;

Sensor-Surface: 4mm (Mechanical Surface Detection)

Electronics: DAE4 Sn1368; Calibrated: 4/22/2013

Phantom: SAM front; Type: QD000P40CD; Serial: TP:1759

Measurement SW: DASY52, Version 52.8 (7); SEMCAD X Version 14.6.10 (7164)

## 1900 MHz System Verification

**Area Scan (7x10x1):** Measurement grid: dx=15mm, dy=15mm

**Zoom Scan (5x5x7)/Cube 0:** Measurement grid: dx=8mm, dy=8mm, dz=5mm

Input Power: 20 dBm (100 mW)

Peak SAR (extrapolated) = 6.97 W/kg

**SAR(1 g) = 3.85 W/kg**

Deviation= -4.94%

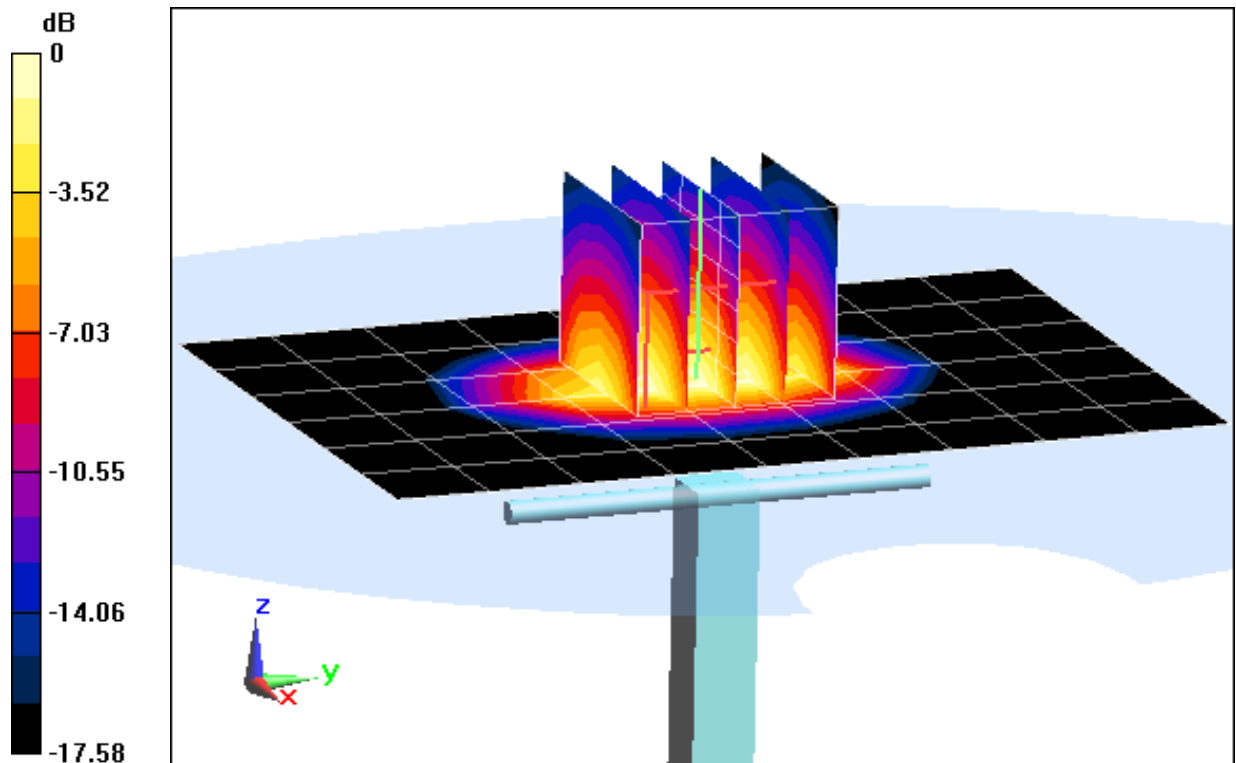

0 dB = 4.34 W/kg = 6.37 dBW/kg

# PCTEST ENGINEERING LABORATORY, INC.

**DUT:Dipole 1900 MHz; Type: D1900V2; Serial: 5d148**

Communication System: UID 0, CW; Frequency: 1900 MHz;Duty Cycle: 1:1

Medium: 1900 Body Medium parameters used (interpolated):

$f = 1900 \text{ MHz}$ ;  $\sigma = 1.574 \text{ S/m}$ ;  $\epsilon_r = 51.155$ ;  $\rho = 1000 \text{ kg/m}^3$

Phantom section: Flat Section; Space: 1.0 cm

Test Date: 01-16-2014; Ambient Temp: 23.8°C; Tissue Temp: 22.5°C

Probe: ES3DV3 - SN3333; ConvF(4.71, 4.71, 4.71); Calibrated: 11/22/2013;

Sensor-Surface: 4mm (Mechanical Surface Detection)

Electronics: DAE4 Sn1408; Calibrated: 11/19/2013

Phantom: ELI v5.0; Type: QDOVA001BB; Serial: 1229

Measurement SW: DASY52, Version 52.8 (7); SEMCAD X Version 14.6.10 (7164)

## 1900 MHz System Verification

**Area Scan (7x10x1):** Measurement grid: dx=15mm, dy=15mm

**Zoom Scan (5x5x7)/Cube 0:** Measurement grid: dx=8mm, dy=8mm, dz=5mm

Input Power: 20 dBm (100 mW)

Peak SAR (extrapolated) = 7.27 W/kg

**SAR(1 g) = 3.98 W/kg**

Deviation= -2.45%

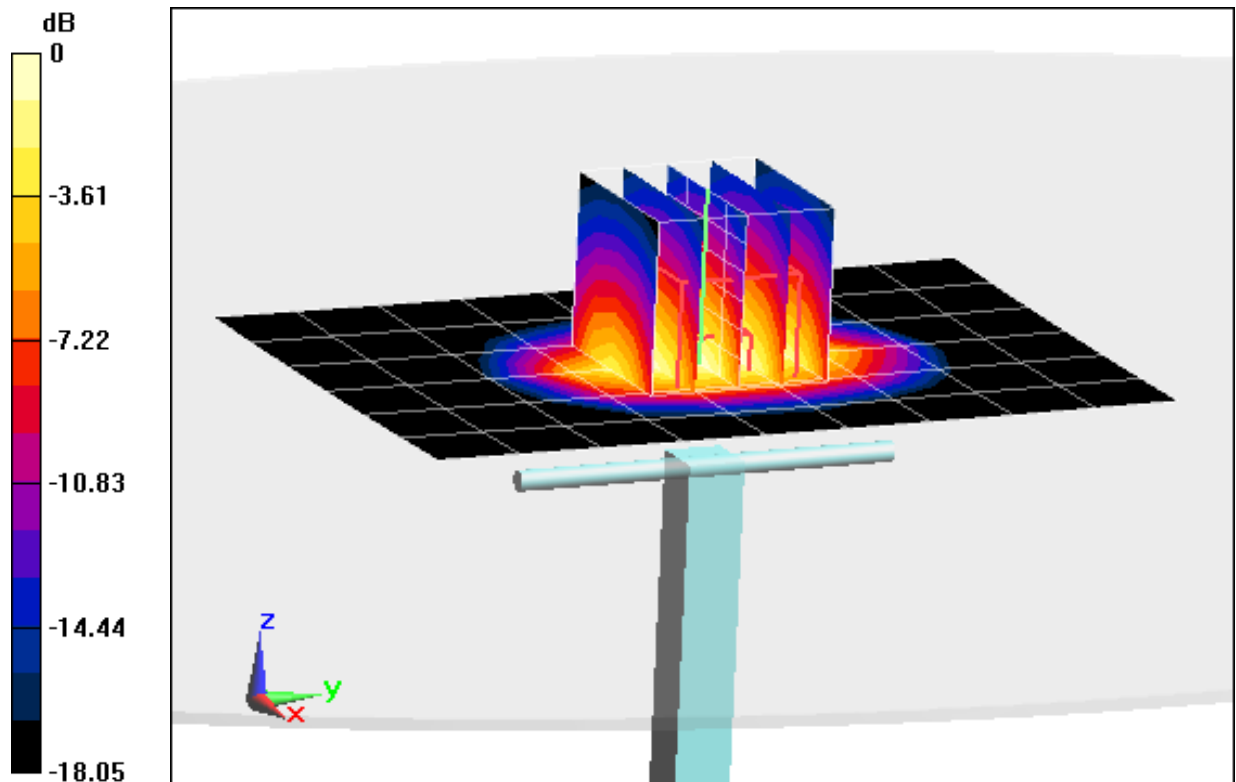

0 dB = 4.46 W/kg = 6.49 dBW/kg

# PCTEST ENGINEERING LABORATORY, INC.

**DUT: Dipole 2450 MHz; Type: D2450V2; Serial: 719**

Communication System: UID 0, CW; Frequency: 2450 MHz; Duty Cycle: 1:1

Medium: 2450 Body Medium parameters used:

$f = 2450 \text{ MHz}$ ;  $\sigma = 2.041 \text{ S/m}$ ;  $\epsilon_r = 50.745$ ;  $\rho = 1000 \text{ kg/m}^3$

Phantom section: Flat Section; Space: 1.0 cm

Test Date: 01-17-2014; Ambient Temp: 21.9°C; Tissue Temp: 22.9°C

Probe: ES3DV3 - SN3209; ConvF(4.34, 4.34, 4.34); Calibrated: 3/15/2013;

Sensor-Surface: 3mm (Mechanical Surface Detection)

Electronics: DAE4 Sn1334; Calibrated: 3/8/2013

Phantom: ELI v5.0; Type: QDOVA002AA; Serial: TP-1158

Measurement SW: DASY52, Version 52.8 (7); SEMCAD X Version 14.6.10 (7164)

## 2450 MHz System Verification

**Area Scan (8x9x1):** Measurement grid: dx=12mm, dy=12mm

**Zoom Scan (7x7x7)/Cube 0:** Measurement grid: dx=5mm, dy=5mm, dz=5mm

Input Power: 20 dBm (100 mW)

Peak SAR (extrapolated) = 11.2 W/kg

**SAR(1 g) = 5.31 W/kg**

Deviation= 2.71%

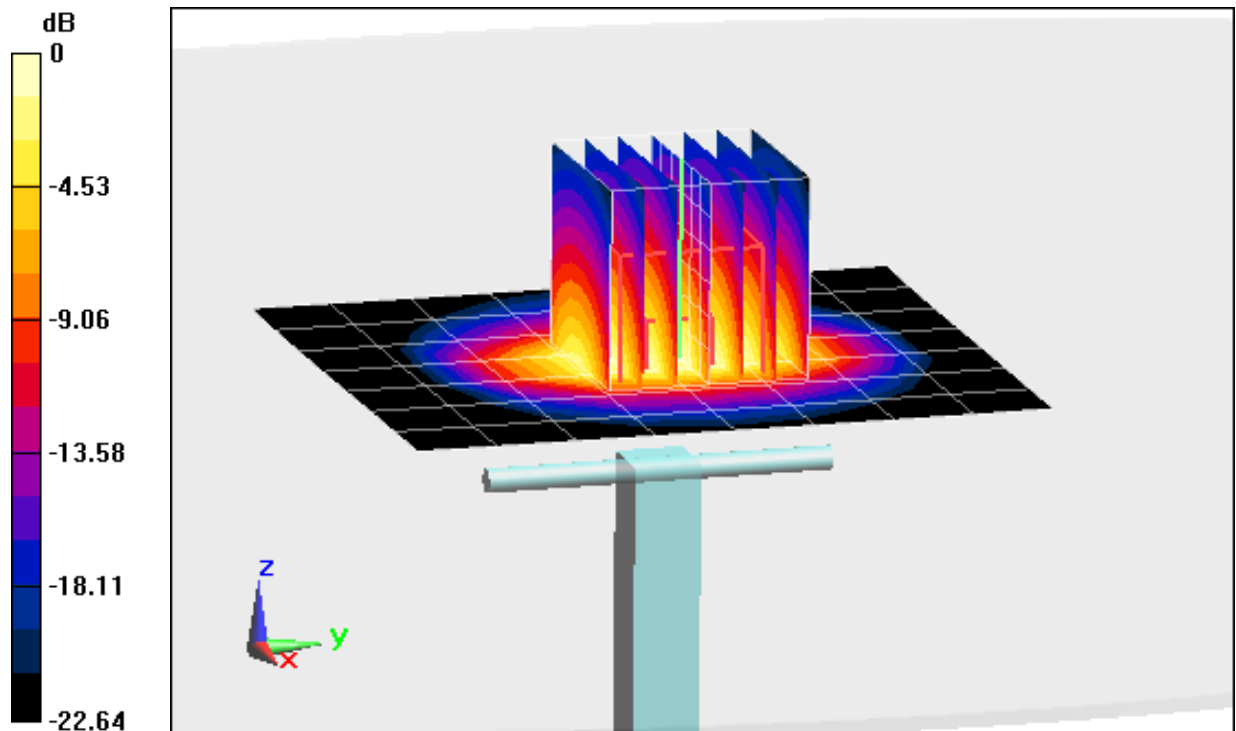

0 dB = 6.85 W/kg = 8.36 dBW/kg

# PCTEST ENGINEERING LABORATORY, INC.

**DUT: Dipole 2450 MHz; Type: D2450V2; Serial: 719**

Communication System: UID 0, CW; Frequency: 2450 MHz; Duty Cycle: 1:1

Medium: 2450 Body Medium parameters used:

$f = 2450 \text{ MHz}$ ;  $\sigma = 1.944 \text{ S/m}$ ;  $\epsilon_r = 50.337$ ;  $\rho = 1000 \text{ kg/m}^3$

Phantom section: Flat Section; Space: 1.0 cm

Test Date: 01-24-2014; Ambient Temp: 23.5°C; Tissue Temp: 23.2°C

Probe: ES3DV3 - SN3333; ConvF(4.22, 4.22, 4.22); Calibrated: 11/22/2013;

Sensor-Surface: 3mm (Mechanical Surface Detection)

Electronics: DAE4 Sn1408; Calibrated: 11/19/2013

Phantom: SAM CRP v4.0; Type: QD000P40CD; Serial: TP:1797

Measurement SW: DASY52, Version 52.8 (7); SEMCAD X Version 14.6.10 (7164)

## 2450 MHz System Verification

**Area Scan (8x9x1):** Measurement grid: dx=12mm, dy=12mm

**Zoom Scan (7x7x7)/Cube 0:** Measurement grid: dx=5mm, dy=5mm, dz=5mm

Input Power: 20 dBm (100 mW)

Peak SAR (extrapolated) = 12.2 W/kg

**SAR(1 g) = 5.52 W/kg**

Deviation= 6.77%

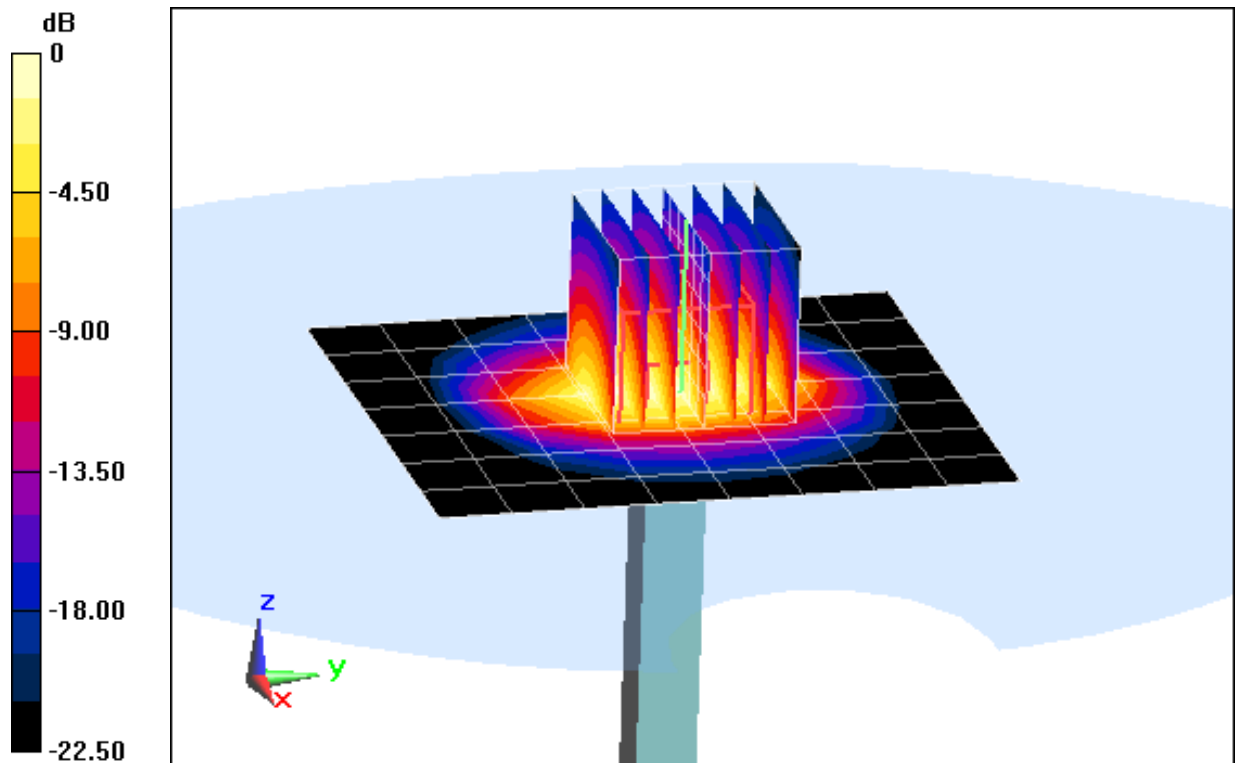

0 dB = 7.17 W/kg = 8.56 dBW/kg

# PCTEST ENGINEERING LABORATORY, INC.

**DUT: Dipole 5200 MHz; Type: D5GHzV2; Serial: 1120**

Communication System: UID 0, CW; Frequency: 5200 MHz; Duty Cycle: 1:1

Medium: 5 GHz Body; Medium parameters used:

$f = 5200 \text{ MHz}$ ;  $\sigma = 5.318 \text{ S/m}$ ;  $\epsilon_r = 47.709$ ;  $\rho = 1000 \text{ kg/m}^3$

Phantom section: Flat Section; Space: 1.0 cm

Test Date: 01-23-2014; Ambient Temp: 24.1°C; Tissue Temp: 22.3°C

Probe: EX3DV4 - SN3914; ConvF(4.52, 4.52, 4.52); Calibrated: 10/23/2013;

Sensor-Surface: 1.4mm (Mechanical Surface Detection)

Electronics: DAE4 Sn1333; Calibrated: 11/19/2013

Phantom: SAM V5.0 Right; Type: QD000P40CD; Serial: 1647

Measurement SW: DASY52, Version 52.8 (7); SEMCAD X Version 14.6.10 (7164)

## 5200 MHz System Verification

**Area Scan (7x8x1):** Measurement grid: dx=10mm, dy=10mm

**Zoom Scan (7x7x7)/Cube 0:** Measurement grid: dx=4mm, dy=4mm, dz=1.4mm; Graded Ratio: 1.4

Input Power: 20.0 dBm (100 mW)

Peak SAR (extrapolated) = 33.0 W/kg

**SAR(1 g) = 7.82 W/kg**

Deviation= 2.09%

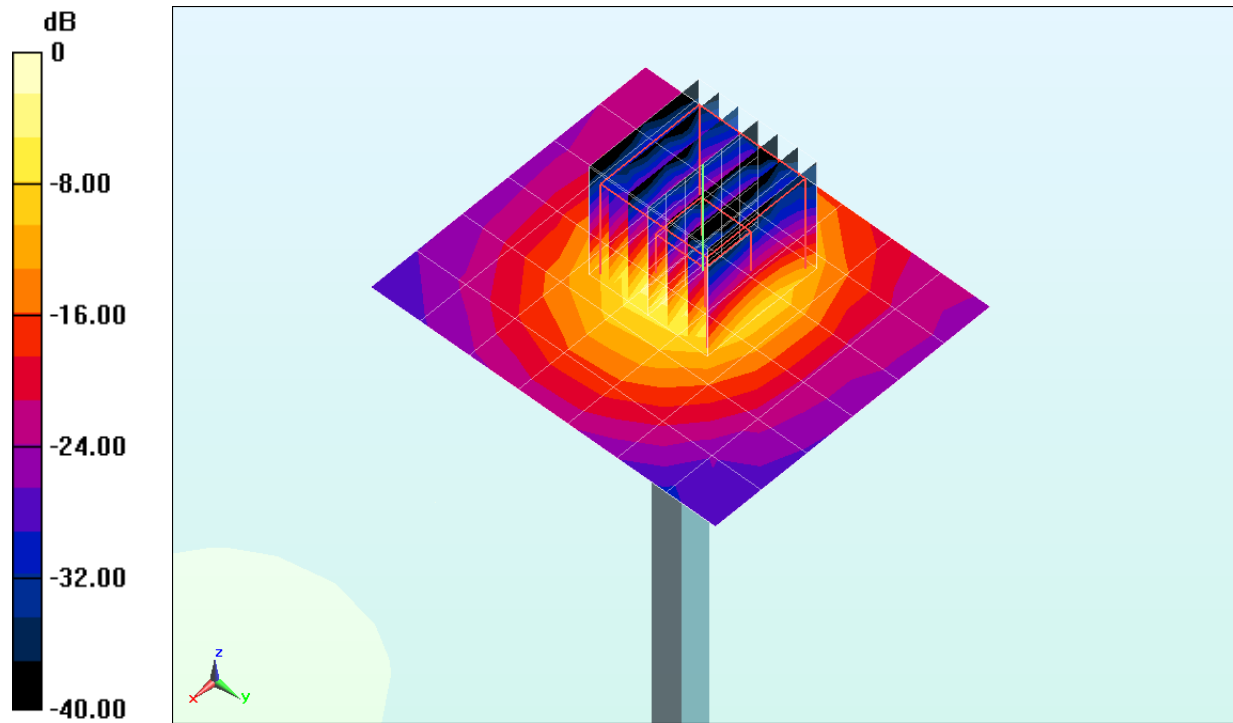

0 dB = 19.9 W/kg = 12.99 dBW/kg

# PCTEST ENGINEERING LABORATORY, INC.

**DUT: Dipole 5300 MHz; Type: D5GHzV2; Serial: 1120**

Communication System: UID 0, CW; Frequency: 5300 MHz; Duty Cycle: 1:1

Medium: 5 GHz Body; Medium parameters used:

$f = 5300 \text{ MHz}$ ;  $\sigma = 5.47 \text{ S/m}$ ;  $\epsilon_r = 47.466$ ;  $\rho = 1000 \text{ kg/m}^3$

Phantom section: Flat Section; Space: 1.0 cm

Test Date: 01-23-2014; Ambient Temp: 23.8°C; Tissue Temp: 22.2°C

Probe: EX3DV4 - SN3914; ConvF(4.32, 4.32, 4.32); Calibrated: 10/23/2013;

Sensor-Surface: 1.4mm (Mechanical Surface Detection)

Electronics: DAE4 Sn1333; Calibrated: 11/19/2013

Phantom: SAM V5.0 Right; Type: QD000P40CD; Serial: 1647

Measurement SW: DASY52, Version 52.8 (7); SEMCAD X Version 14.6.10 (7164)

## 5300 MHz System Verification

**Area Scan (7x8x1):** Measurement grid: dx=10mm, dy=10mm

**Zoom Scan (8x8x7)/Cube 0:** Measurement grid: dx=4mm, dy=4mm, dz=1.4mm; Graded Ratio: 1.4

Input Power: 20.0 dBm (100 mW)

Peak SAR (extrapolated) = 35.0 W/kg

**SAR(1 g) = 7.97 W/kg**

Deviation = 3.78%

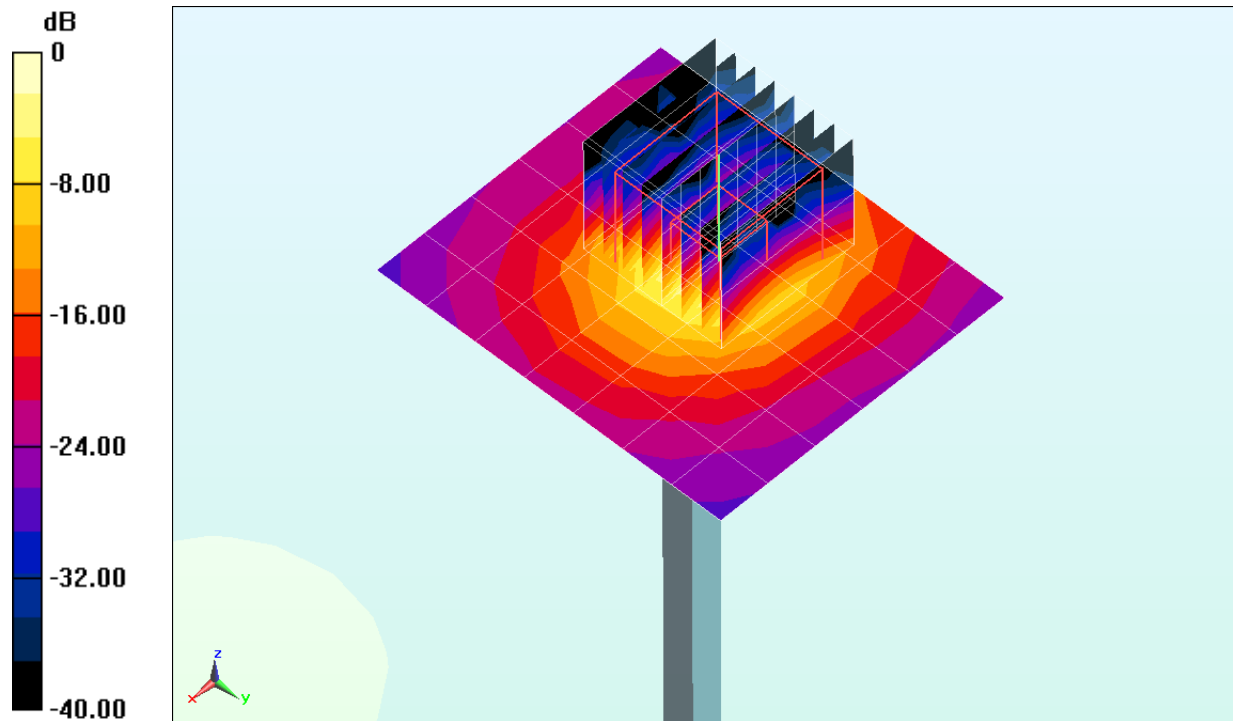

0 dB = 20.5 W/kg = 13.12 dBW/kg

# PCTEST ENGINEERING LABORATORY, INC.

**DUT: Dipole 5500 MHz; Type: D5GHzV2; Serial: 1120**

Communication System: UID 0, CW; Frequency: 5500 MHz; Duty Cycle: 1:1

Medium: 5 GHz Body; Medium parameters used:

$f = 5500 \text{ MHz}$ ;  $\sigma = 5.792 \text{ S/m}$ ;  $\epsilon_r = 46.979$ ;  $\rho = 1000 \text{ kg/m}^3$

Phantom section: Flat Section; Space: 1.0 cm

Test Date: 01-23-2014; Ambient Temp: 24.1°C; Tissue Temp: 22.3°C

Probe: EX3DV4 - SN3914; ConvF(4.07, 4.07, 4.07); Calibrated: 10/23/2013;

Sensor-Surface: 1.4mm (Mechanical Surface Detection)

Electronics: DAE4 Sn1333; Calibrated: 11/19/2013

Phantom: SAM V5.0 Right; Type: QD000P40CD; Serial: 1647

Measurement SW: DASYS2, Version 52.8 (7); SEMCAD X Version 14.6.10 (7164)

## 5500 MHz System Verification

**Area Scan (7x8x1):** Measurement grid: dx=10mm, dy=10mm

**Zoom Scan (7x7x7)/Cube 0:** Measurement grid: dx=4mm, dy=4mm, dz=1.4mm; Graded Ratio: 1.4

Input Power: 20.0 dBm (100 mW)

Peak SAR (extrapolated) = 37.4 W/kg

**SAR(1 g) = 8.11 W/kg**

Deviation = 1.63%

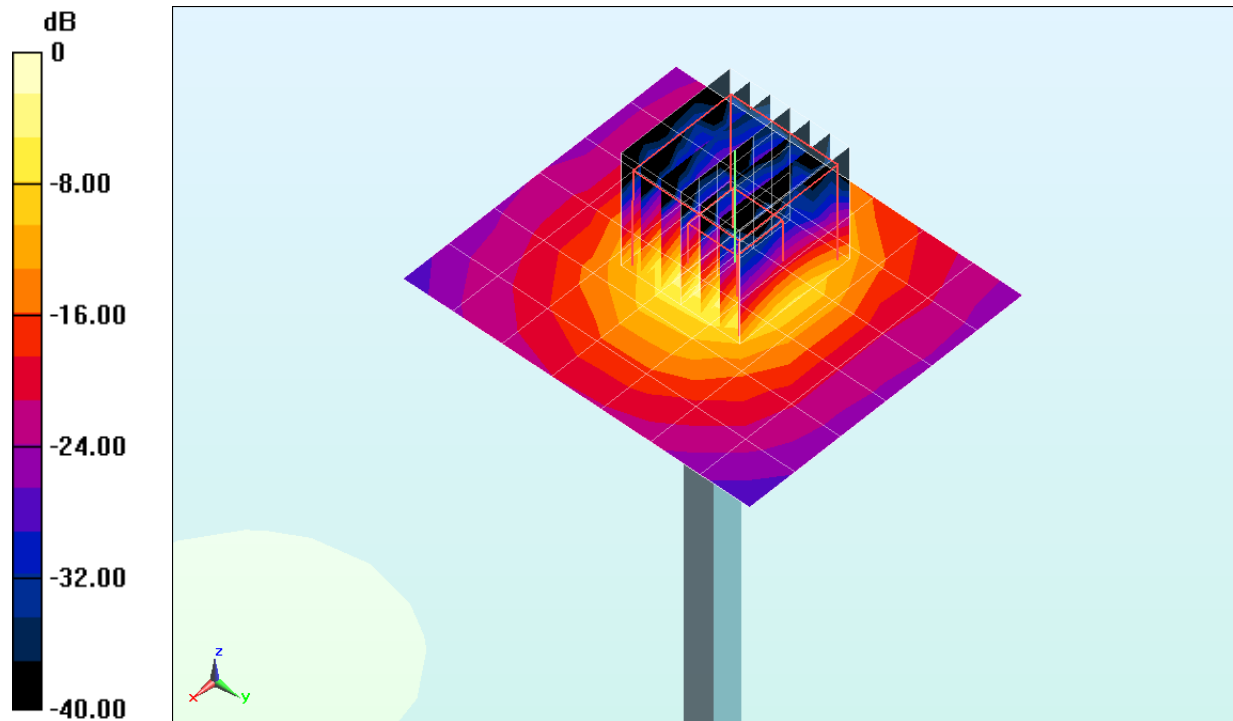

0 dB = 21.3 W/kg = 13.28 dBW/kg

# PCTEST ENGINEERING LABORATORY, INC.

**DUT: Dipole 5600 MHz; Type: D5GHzV2; Serial: 1120**

Communication System: UID 0, CW; Frequency: 5600 MHz; Duty Cycle: 1:1

Medium: 5 GHz Body; Medium parameters used:

$f = 5600 \text{ MHz}$ ;  $\sigma = 5.932 \text{ S/m}$ ;  $\epsilon_r = 46.707$ ;  $\rho = 1000 \text{ kg/m}^3$

Phantom section: Flat Section; Space: 1.0 cm

Test Date: 01-23-2014; Ambient Temp: 24.3°C; Tissue Temp: 22.3°C

Probe: EX3DV4 - SN3914; ConvF(3.97, 3.97, 3.97); Calibrated: 10/23/2013;

Sensor-Surface: 1.4mm (Mechanical Surface Detection)

Electronics: DAE4 Sn1333; Calibrated: 11/19/2013

Phantom: SAM V5.0 Right; Type: QD000P40CD; Serial: 1647

Measurement SW: DASY52, Version 52.8 (7); SEMCAD X Version 14.6.10 (7164)

## 5600 MHz System Verification

**Area Scan (7x8x1):** Measurement grid: dx=10mm, dy=10mm

**Zoom Scan (7x7x7)/Cube 0:** Measurement grid: dx=4mm, dy=4mm, dz=1.4mm; Graded Ratio: 1.4

Input Power: 20.0 dBm (100 mW)

Peak SAR (extrapolated) = 39.4 W/kg

**SAR(1 g) = 8.3 W/kg**

Deviation = 2.85%

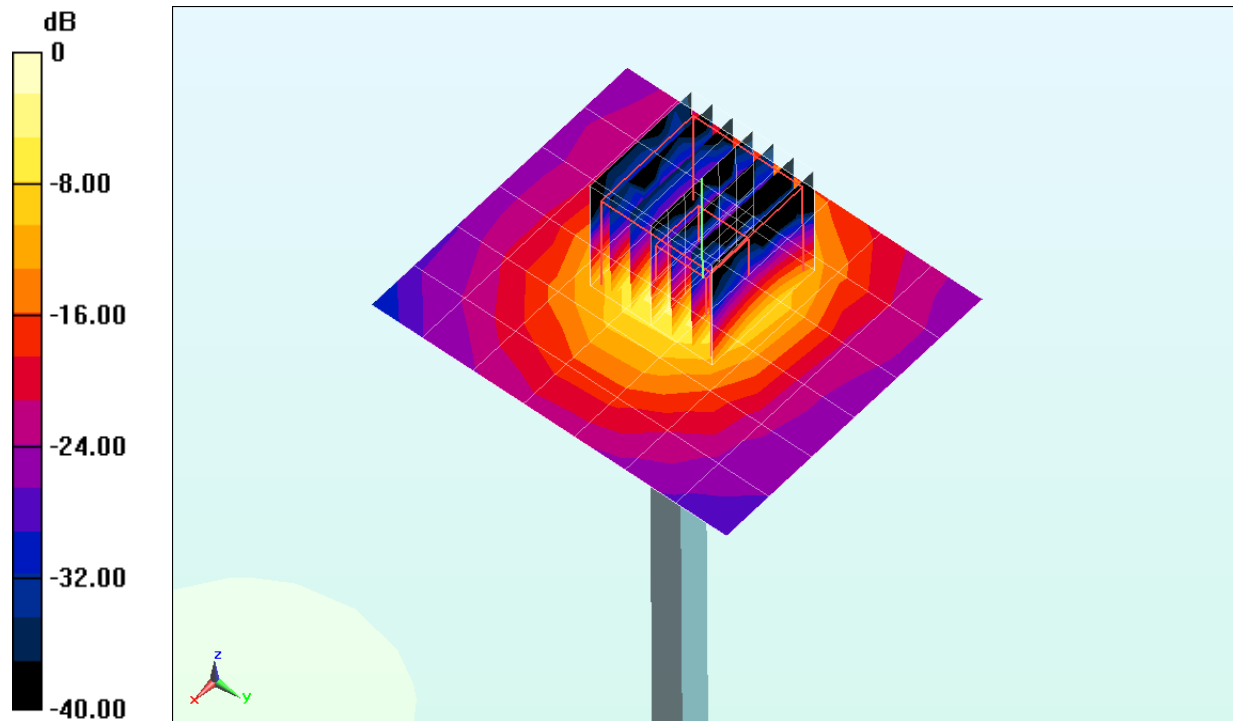

0 dB = 22.0 W/kg = 13.42 dBW/kg

# PCTEST ENGINEERING LABORATORY, INC.

**DUT: Dipole 5800 MHz; Type: D5GHzV2; Serial: 1120**

Communication System: UID 0, CW; Frequency: 5800 MHz; Duty Cycle: 1:1

Medium: 5 GHz Body; Medium parameters used:

$f = 5800 \text{ MHz}$ ;  $\sigma = 6.236 \text{ S/m}$ ;  $\epsilon_r = 46.236$ ;  $\rho = 1000 \text{ kg/m}^3$

Phantom section: Flat Section; Space: 1.0 cm

Test Date: 01-23-2014; Ambient Temp: 24.4°C; Tissue Temp: 22.3°C

Probe: EX3DV4 - SN3914; ConvF(4.14, 4.14, 4.14); Calibrated: 10/23/2013;

Sensor-Surface: 1.4mm (Mechanical Surface Detection)

Electronics: DAE4 Sn1333; Calibrated: 11/19/2013

Phantom: SAM V5.0 Right; Type: QD000P40CD; Serial: 1647

Measurement SW: DASY52, Version 52.8 (7); SEMCAD X Version 14.6.10 (7164)

## 5800 MHz System Verification

**Area Scan (7x8x1):** Measurement grid: dx=10mm, dy=10mm

**Zoom Scan (8x8x7)/Cube 0:** Measurement grid: dx=4mm, dy=4mm, dz=1.4mm; Graded Ratio: 1.4

Input Power: 20.0 dBm (100 mW)

Peak SAR (extrapolated) = 35.1 W/kg

**SAR(1 g) = 7.18 W/kg**

Deviation = -4.90%

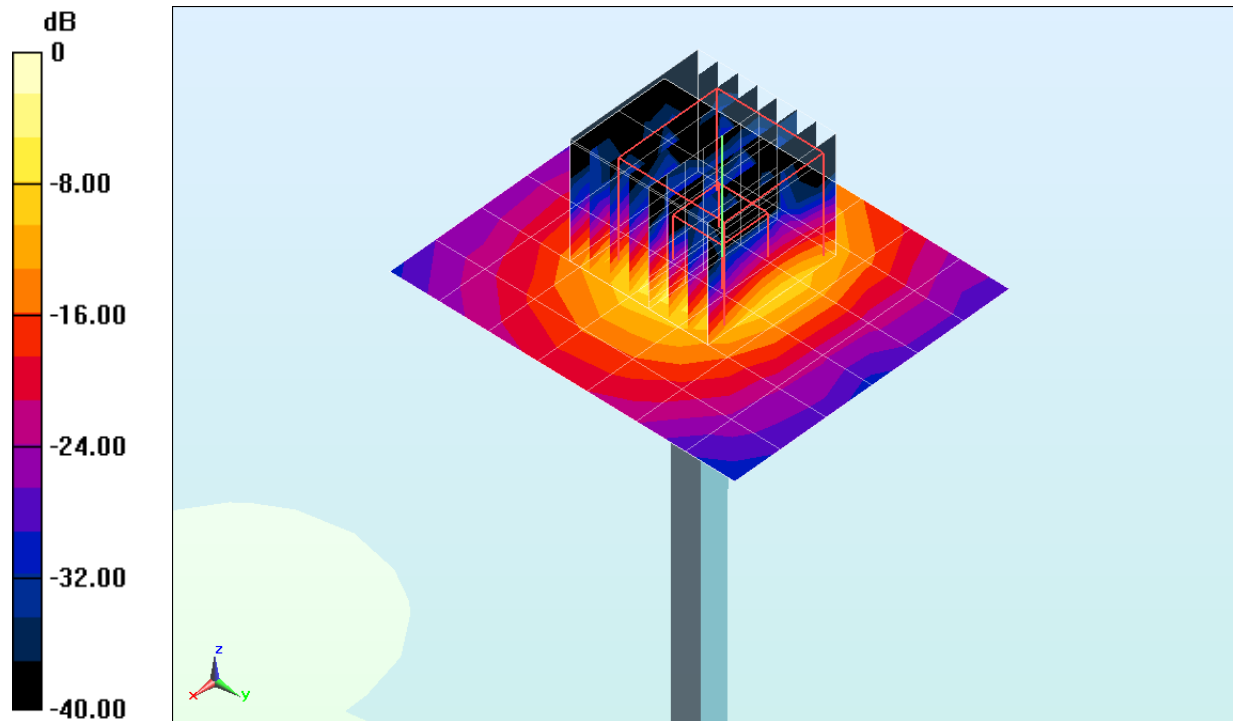

0 dB = 19.2 W/kg = 12.83 dBW/kg

## APPENDIX C: PROBE CALIBRATION



Accredited by the Swiss Accreditation Service (SAS)  
The Swiss Accreditation Service is one of the signatories to the EA  
Multilateral Agreement for the recognition of calibration certificates

Accreditation No.: **SCS 108**

Client **PC Test**

Certificate No: **D835V2-4d119\_Apr13**

## CALIBRATION CERTIFICATE

Object **D835V2 - SN: 4d119**

Calibration procedure(s) **QA CAL-05.v9  
Calibration procedure for dipole validation kits above 700 MHz**

Calibration date: **April 25, 2013**

✓  
KOK  
5/8/13

This calibration certificate documents the traceability to national standards, which realize the physical units of measurements (SI).  
The measurements and the uncertainties with confidence probability are given on the following pages and are part of the certificate.

All calibrations have been conducted in the closed laboratory facility: environment temperature ( $22 \pm 3$ )°C and humidity < 70%.

Calibration Equipment used (M&TE critical for calibration)

| Primary Standards           | ID #               | Cal Date (Certificate No.)        | Scheduled Calibration  |
|-----------------------------|--------------------|-----------------------------------|------------------------|
| Power meter EPM-442A        | GB37480704         | 01-Nov-12 (No. 217-01640)         | Oct-13                 |
| Power sensor HP 8481A       | US37292783         | 01-Nov-12 (No. 217-01640)         | Oct-13                 |
| Reference 20 dB Attenuator  | SN: 5058 (20k)     | 04-Apr-13 (No. 217-01736)         | Apr-14                 |
| Type-N mismatch combination | SN: 5047.3 / 06327 | 04-Apr-13 (No. 217-01739)         | Apr-14                 |
| Reference Probe ES3DV3      | SN: 3205           | 28-Dec-12 (No. ES3-3205_Dec12)    | Dec-13                 |
| DAE4                        | SN: 909            | 11-Sep-12 (No. DAE4-909_Sep12)    | Sep-13                 |
| Secondary Standards         | ID #               | Check Date (in house)             | Scheduled Check        |
| Power sensor HP 8481A       | MY41092317         | 18-Oct-02 (in house check Oct-11) | In house check: Oct-13 |
| RF generator R&S SMT-06     | 100005             | 04-Aug-99 (in house check Oct-11) | In house check: Oct-13 |
| Network Analyzer HP 8753E   | US37390585 S4206   | 18-Oct-01 (in house check Oct-12) | In house check: Oct-13 |

Calibrated by: **Claudio Leubler**      Name: **Claudio Leubler**      Function: **Laboratory Technician**

Approved by: **Katja Pokovic**      Name: **Katja Pokovic**      Technical Manager

Signature

Issued: April 26, 2013

This calibration certificate shall not be reproduced except in full without written approval of the laboratory.



Accredited by the Swiss Accreditation Service (SAS)  
The Swiss Accreditation Service is one of the signatories to the EA  
Multilateral Agreement for the recognition of calibration certificates

Accreditation No.: **SCS 108**

### Glossary:

|       |                                 |
|-------|---------------------------------|
| TSL   | tissue simulating liquid        |
| ConvF | sensitivity in TSL / NORM x,y,z |
| N/A   | not applicable or not measured  |

### Calibration is Performed According to the Following Standards:

- IEEE Std 1528-2003, "IEEE Recommended Practice for Determining the Peak Spatial-Averaged Specific Absorption Rate (SAR) in the Human Head from Wireless Communications Devices: Measurement Techniques", December 2003
- IEC 62209-1, "Procedure to measure the Specific Absorption Rate (SAR) for hand-held devices used in close proximity to the ear (frequency range of 300 MHz to 3 GHz)", February 2005
- Federal Communications Commission Office of Engineering & Technology (FCC OET), "Evaluating Compliance with FCC Guidelines for Human Exposure to Radiofrequency Electromagnetic Fields; Additional Information for Evaluating Compliance of Mobile and Portable Devices with FCC Limits for Human Exposure to Radiofrequency Emissions", Supplement C (Edition 01-01) to Bulletin 65

### Additional Documentation:

- DASY4/5 System Handbook

### Methods Applied and Interpretation of Parameters:

- Measurement Conditions:** Further details are available from the Validation Report at the end of the certificate. All figures stated in the certificate are valid at the frequency indicated.
- Antenna Parameters with TSL:** The dipole is mounted with the spacer to position its feed point exactly below the center marking of the flat phantom section, with the arms oriented parallel to the body axis.
- Feed Point Impedance and Return Loss:** These parameters are measured with the dipole positioned under the liquid filled phantom. The impedance stated is transformed from the measurement at the SMA connector to the feed point. The Return Loss ensures low reflected power. No uncertainty required.
- Electrical Delay:** One-way delay between the SMA connector and the antenna feed point. No uncertainty required.
- SAR measured:** SAR measured at the stated antenna input power.
- SAR normalized:** SAR as measured, normalized to an input power of 1 W at the antenna connector.
- SAR for nominal TSL parameters:** The measured TSL parameters are used to calculate the nominal SAR result.

The reported uncertainty of measurement is stated as the standard uncertainty of measurement multiplied by the coverage factor  $k=2$ , which for a normal distribution corresponds to a coverage probability of approximately 95%.

## Measurement Conditions

DASY system configuration, as far as not given on page 1.

|                              |                        |             |
|------------------------------|------------------------|-------------|
| DASY Version                 | DASY5                  | V52.8.6     |
| Extrapolation                | Advanced Extrapolation |             |
| Phantom                      | Modular Flat Phantom   |             |
| Distance Dipole Center - TSL | 15 mm                  | with Spacer |
| Zoom Scan Resolution         | dx, dy, dz = 5 mm      |             |
| Frequency                    | 835 MHz $\pm$ 1 MHz    |             |

## Head TSL parameters

The following parameters and calculations were applied.

|   | Temperature         | Permittivity   | Conductivity         |
|---|---------------------|----------------|----------------------|
| Nominal Head TSL parameters             | 22.0 °C             | 41.5           | 0.90 mho/m           |
| Measured Head TSL parameters            | (22.0 $\pm$ 0.2) °C | 40.8 $\pm$ 6 % | 0.94 mho/m $\pm$ 6 % |
| Head TSL temperature change during test | < 0.5 °C            | ----           | ----                 |

## SAR result with Head TSL

| SAR averaged over 1 cm <sup>3</sup> (1 g) of Head TSL | Condition          |  |
|---|--------------------|--|
| SAR measured  | 250 mW input power | 2.51 W/kg                                      |
| SAR for nominal Head TSL parameters                   | normalized to 1W   | <b>9.68 W/kg <math>\pm</math> 17.0 % (k=2)</b> |

| SAR averaged over 10 cm <sup>3</sup> (10 g) of Head TSL | condition          |  |
|---|--------------------|--|
| SAR measured  | 250 mW input power | 1.62 W/kg                                      |
| SAR for nominal Head TSL parameters                     | normalized to 1W   | <b>6.30 W/kg <math>\pm</math> 16.5 % (k=2)</b> |

## Body TSL parameters

The following parameters and calculations were applied.

|   | Temperature         | Permittivity   | Conductivity         |
|---|---------------------|----------------|----------------------|
| Nominal Body TSL parameters             | 22.0 °C             | 55.2           | 0.97 mho/m           |
| Measured Body TSL parameters            | (22.0 $\pm$ 0.2) °C | 54.0 $\pm$ 6 % | 1.01 mho/m $\pm$ 6 % |
| Body TSL temperature change during test | < 0.5 °C            | ----           | ----                 |

## SAR result with Body TSL

| SAR averaged over 1 cm <sup>3</sup> (1 g) of Body TSL | Condition          |  |
|---|--------------------|--|
| SAR measured  | 250 mW input power | 2.47 W/kg                                      |
| SAR for nominal Body TSL parameters                   | normalized to 1W   | <b>9.54 W/kg <math>\pm</math> 17.0 % (k=2)</b> |

| SAR averaged over 10 cm <sup>3</sup> (10 g) of Body TSL | condition          |  |
|---|--------------------|--|
| SAR measured  | 250 mW input power | 1.62 W/kg                                      |
| SAR for nominal Body TSL parameters                     | normalized to 1W   | <b>6.31 W/kg <math>\pm</math> 16.5 % (k=2)</b> |

## Appendix

### Antenna Parameters with Head TSL

|                                      |                                |
|--------------------------------------|--------------------------------|
| Impedance, transformed to feed point | 50.1 $\Omega$ - 4.7 j $\Omega$ |
| Return Loss                          | - 26.6 dB                      |

### Antenna Parameters with Body TSL

|                                      |                                |
|--------------------------------------|--------------------------------|
| Impedance, transformed to feed point | 45.8 $\Omega$ - 6.3 j $\Omega$ |
| Return Loss                          | - 22.1 dB                      |

### General Antenna Parameters and Design

|                                  |          |
|----------------------------------|----------|
| Electrical Delay (one direction) | 1.385 ns |
|----------------------------------|----------|

After long term use with 100W radiated power, only a slight warming of the dipole near the feedpoint can be measured.

The dipole is made of standard semirigid coaxial cable. The center conductor of the feeding line is directly connected to the second arm of the dipole. The antenna is therefore short-circuited for DC-signals. On some of the dipoles, small end caps are added to the dipole arms in order to improve matching when loaded according to the position as explained in the "Measurement Conditions" paragraph. The SAR data are not affected by this change. The overall dipole length is still according to the Standard.

No excessive force must be applied to the dipole arms, because they might bend or the soldered connections near the feedpoint may be damaged.

### Additional EUT Data

|                 |               |
|-----------------|---------------|
| Manufactured by | SPEAG         |
| Manufactured on | June 29, 2010 |

## DASY5 Validation Report for Head TSL

Date: 25.04.2013

Test Laboratory: SPEAG, Zurich, Switzerland

**DUT: Dipole 835 MHz; Type: D835V2; Serial: D835V2 - SN: 4d119**

Communication System: UID 0 - CW; Frequency: 835 MHz

Medium parameters used:  $f = 835$  MHz;  $\sigma = 0.94$  S/m;  $\epsilon_r = 40.8$ ;  $\rho = 1000$  kg/m<sup>3</sup>

Phantom section: Flat Section

Measurement Standard: DASY5 (IEEE/IEC/ANSI C63.19-2007)

DASY52 Configuration:

- Probe: ES3DV3 - SN3205; ConvF(6.05, 6.05, 6.05); Calibrated: 28.12.2012;
- Sensor-Surface: 3mm (Mechanical Surface Detection)
- Electronics: DAE4 Sn909; Calibrated: 11.09.2012
- Phantom: Flat Phantom 4.9L; Type: QD000P49AA; Serial: 1001
- DASY52 52.8.6(1115); SEMCAD X 14.6.9(7117)

**Dipole Calibration for Head Tissue/Pin=250 mW, d=15mm/Zoom Scan (7x7x7)/Cube 0:**

Measurement grid: dx=5mm, dy=5mm, dz=5mm

Reference Value = 57.387 V/m; Power Drift = 0.03 dB

Peak SAR (extrapolated) = 3.86 W/kg

**SAR(1 g) = 2.51 W/kg; SAR(10 g) = 1.62 W/kg**

Maximum value of SAR (measured) = 2.93 W/kg

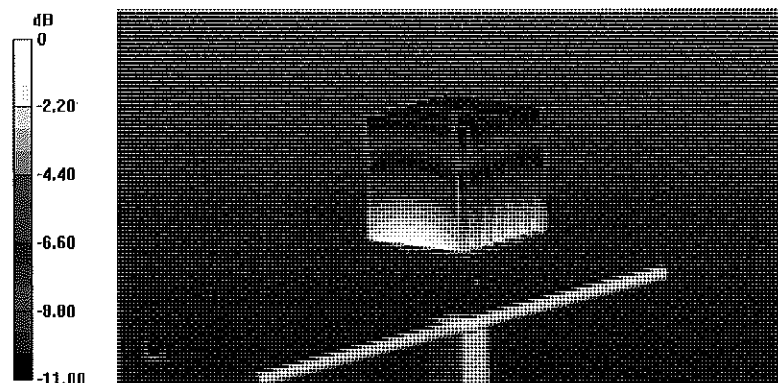

0 dB = 2.93 W/kg = 4.67 dBW/kg

# Impedance Measurement Plot for Head TSL

25 Apr 2013 09:11:06

CH1 S11 1 U FS

1: 50.061  $\Omega$  -4.6621  $\Omega$  40.884 pF

835.000 000 MHz

\*  
Del

CA

Avg  
16

H1 d

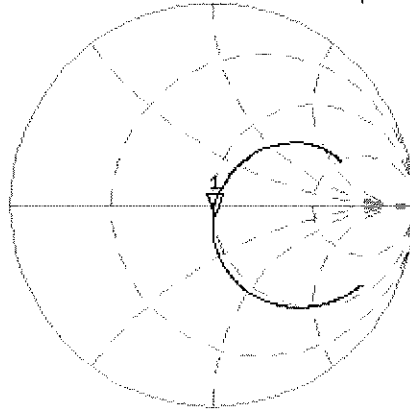

CH2 S11 LOG

5 dB/REF -20 dB

1: -26.641 dB 835.000 000 MHz

CA

Avg  
16

H1 d

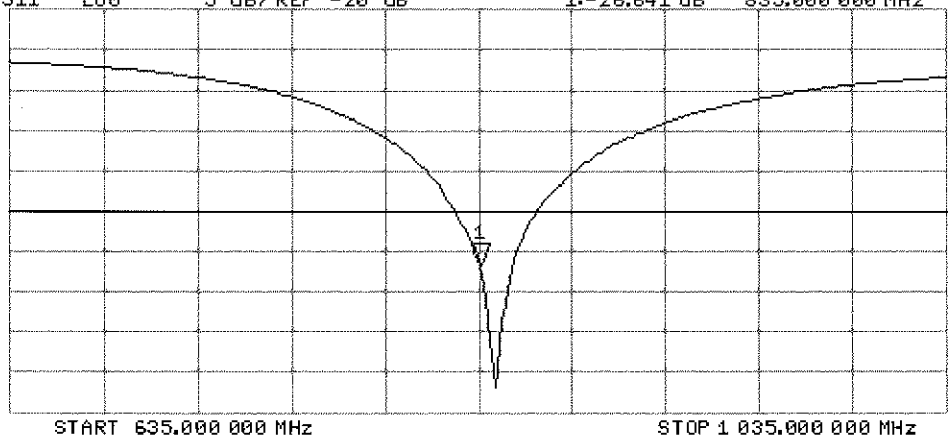

## DASY5 Validation Report for Body TSL

Date: 24.04.2013

Test Laboratory: SPEAG, Zurich, Switzerland

**DUT: Dipole 835 MHz; Type: D835V2; Serial: D835V2 - SN: 4d119**

Communication System: UID 0 - CW; Frequency: 835 MHz

Medium parameters used:  $f = 835$  MHz;  $\sigma = 1.01$  S/m;  $\epsilon_r = 54$ ;  $\rho = 1000$  kg/m<sup>3</sup>

Phantom section: Flat Section

Measurement Standard: DASY5 (IEEE/IEC/ANSI C63.19-2007)

DASY52 Configuration:

- Probe: ES3DV3 - SN3205; ConvF(6.04, 6.04, 6.04); Calibrated: 28.12.2012;
- Sensor-Surface: 3mm (Mechanical Surface Detection)
- Electronics: DAE4 Sn909; Calibrated: 11.09.2012
- Phantom: Flat Phantom 4.9L; Type: QD000P49AA; Serial: 1001
- DASY52 52.8.6(1115); SEMCAD X 14.6.9(7117)

### **Dipole Calibration for Body Tissue/Pin=250 mW, d=15mm/Zoom Scan (7x7x7)/Cube 0:**

Measurement grid: dx=5mm, dy=5mm, dz=5mm

Reference Value = 55.178 V/m; Power Drift = 0.03 dB

Peak SAR (extrapolated) = 3.68 W/kg

**SAR(1 g) = 2.47 W/kg; SAR(10 g) = 1.62 W/kg**

Maximum value of SAR (measured) = 2.89 W/kg

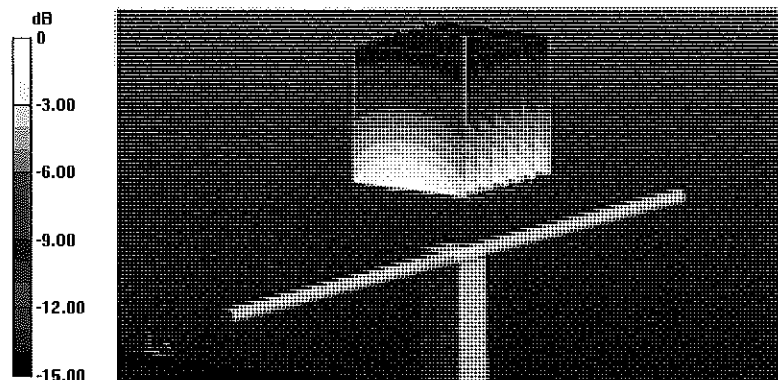

0 dB = 2.89 W/kg = 4.61 dBW/kg

# Impedance Measurement Plot for Body TSL

24 Apr 2013 11:33:44

CH1 S11 1 U FS

2: 45.773  $\Omega$  -6.2773  $\Delta$  30.364 pF

835.000 000 MHz

\*  
DeI

CΔ

Avg  
16

H1d

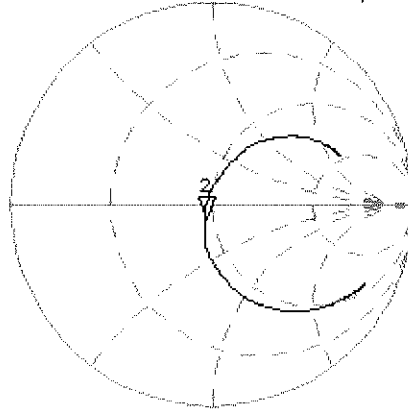

CH2 S11 LOG

5 dB/REF -20 dB

2: -22.065 dB

835.000 000 MHz

CΔ

Avg  
16

H1d

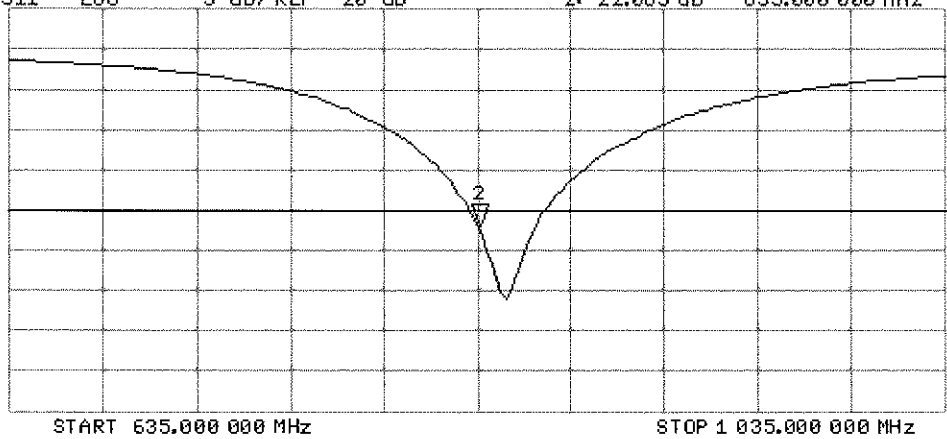

START 635.000 000 MHz

STOP 1 035.000 000 MHz



Accredited by the Swiss Accreditation Service (SAS)  
 The Swiss Accreditation Service is one of the signatories to the EA  
 Multilateral Agreement for the recognition of calibration certificates

Accreditation No.: **SCS 108**

Client **PC Test**

Certificate No: **ES3-3022\_Aug13**

**CALIBRATION CERTIFICATE**

Object **ES3DV2 - SN:3022**

Calibration procedure(s) **QA CAL-01.v9, QA CAL-23.v5, QA CAL-25.v6  
 Calibration procedure for dosimetric E-field probes**

Calibration date: **August 22, 2013** *UTC*  
*9/13/13*

This calibration certificate documents the traceability to national standards, which realize the physical units of measurements (SI).  
 The measurements and the uncertainties with confidence probability are given on the following pages and are part of the certificate.

All calibrations have been conducted in the closed laboratory facility: environment temperature (22 ± 3)°C and humidity < 70%.

Calibration Equipment used (M&TE critical for calibration)

| Primary Standards          | ID              | Cal Date (Certificate No.)        | Scheduled Calibration  |
|----------------------------|-----------------|-----------------------------------|------------------------|
| Power meter E4419B         | GB41293874      | 04-Apr-13 (No. 217-01733)         | Apr-14                 |
| Power sensor E4412A        | MY41498087      | 04-Apr-13 (No. 217-01733)         | Apr-14                 |
| Reference 3 dB Attenuator  | SN: S5054 (3c)  | 04-Apr-13 (No. 217-01737)         | Apr-14                 |
| Reference 20 dB Attenuator | SN: S5277 (20x) | 04-Apr-13 (No. 217-01735)         | Apr-14                 |
| Reference 30 dB Attenuator | SN: S5129 (30b) | 04-Apr-13 (No. 217-01738)         | Apr-14                 |
| Reference Probe ES3DV2     | SN: 3013        | 28-Dec-12 (No. ES3-3013_Dec12)    | Dec-13                 |
| DAE4                       | SN: 660         | 31-Jan-13 (No. DAE4-660_Jan13)    | Jan-14                 |
| Secondary Standards        | ID              | Check Date (in house)             | Scheduled Check        |
| RF generator HP 8648C      | US3642U01700    | 4-Aug-99 (in house check Apr-13)  | In house check: Apr-15 |
| Network Analyzer HP 8753E  | US37390585      | 18-Oct-01 (in house check Oct-12) | In house check: Oct-13 |

|                | Name           | Function              | Signature |
|----------------|----------------|-----------------------|-----------|
| Calibrated by: | Jeton Kastrati | Laboratory Technician |           |
| Approved by:   | Katja Pokovic  | Technical Manager     |           |

Issued: August 23, 2013

This calibration certificate shall not be reproduced except in full without written approval of the laboratory.



Accredited by the Swiss Accreditation Service (SAS)

Accreditation No.: **SCS 108**

The Swiss Accreditation Service is one of the signatories to the EA Multilateral Agreement for the recognition of calibration certificates

### Glossary:

|                          |  |
|--------------------------|--|
| TSL                      | tissue simulating liquid   |
| NORM <sub>x,y,z</sub>    | sensitivity in free space  |
| ConvF                    | sensitivity in TSL / NORM <sub>x,y,z</sub>   |
| DCP                      | diode compression point  |
| CF                       | crest factor (1/duty_cycle) of the RF signal   |
| A, B, C, D               | modulation dependent linearization parameters  |
| Polarization $\varphi$   | $\varphi$ rotation around probe axis   |
| Polarization $\vartheta$ | $\vartheta$ rotation around an axis that is in the plane normal to probe axis (at measurement center), i.e., $\vartheta = 0$ is normal to probe axis |

### Calibration is Performed According to the Following Standards:

- IEEE Std 1528-2003, "IEEE Recommended Practice for Determining the Peak Spatial-Averaged Specific Absorption Rate (SAR) in the Human Head from Wireless Communications Devices: Measurement Techniques", December 2003
- IEC 62209-1, "Procedure to measure the Specific Absorption Rate (SAR) for hand-held devices used in close proximity to the ear (frequency range of 300 MHz to 3 GHz)", February 2005

### Methods Applied and Interpretation of Parameters:

- NORM<sub>x,y,z</sub>**: Assessed for E-field polarization  $\vartheta = 0$  ( $f \leq 900$  MHz in TEM-cell;  $f > 1800$  MHz: R22 waveguide). NORM<sub>x,y,z</sub> are only intermediate values, i.e., the uncertainties of NORM<sub>x,y,z</sub> does not affect the E<sup>2</sup>-field uncertainty inside TSL (see below ConvF).
- NORM(f)<sub>x,y,z</sub>** = NORM<sub>x,y,z</sub> \* frequency\_response (see Frequency Response Chart). This linearization is implemented in DASY4 software versions later than 4.2. The uncertainty of the frequency response is included in the stated uncertainty of ConvF.
- DCP<sub>x,y,z</sub>**: DCP are numerical linearization parameters assessed based on the data of power sweep with CW signal (no uncertainty required). DCP does not depend on frequency nor media.
- PAR**: PAR is the Peak to Average Ratio that is not calibrated but determined based on the signal characteristics
- A<sub>x,y,z</sub>; B<sub>x,y,z</sub>; C<sub>x,y,z</sub>; D<sub>x,y,z</sub>; VR<sub>x,y,z</sub>**: A, B, C, D are numerical linearization parameters assessed based on the data of power sweep for specific modulation signal. The parameters do not depend on frequency nor media. VR is the maximum calibration range expressed in RMS voltage across the diode.
- ConvF and Boundary Effect Parameters**: Assessed in flat phantom using E-field (or Temperature Transfer Standard for  $f \leq 800$  MHz) and inside waveguide using analytical field distributions based on power measurements for  $f > 800$  MHz. The same setups are used for assessment of the parameters applied for boundary compensation (alpha, depth) of which typical uncertainty values are given. These parameters are used in DASY4 software to improve probe accuracy close to the boundary. The sensitivity in TSL corresponds to NORM<sub>x,y,z</sub> \* ConvF whereby the uncertainty corresponds to that given for ConvF. A frequency dependent ConvF is used in DASY version 4.4 and higher which allows extending the validity from  $\pm 50$  MHz to  $\pm 100$  MHz.
- Spherical isotropy (3D deviation from isotropy)**: in a field of low gradients realized using a flat phantom exposed by a patch antenna.
- Sensor Offset**: The sensor offset corresponds to the offset of virtual measurement center from the probe tip (on probe axis). No tolerance required.

# Probe ES3DV2

## SN:3022

Manufactured: April 15, 2003  
Calibrated: August 22, 2013

Calibrated for DASY/EASY Systems  
(Note: non-compatible with DASY2 system!)

## DASY/EASY - Parameters of Probe: ES3DV2 - SN:3022

### Basic Calibration Parameters

|   | Sensor X | Sensor Y | Sensor Z | Unc (k=2) |
|---|----------|----------|----------|-----------|
| Norm ( $\mu\text{V}/(\text{V}/\text{m})^2$ ) <sup>A</sup> | 1.00     | 1.04     | 0.99     | ± 10.1 %  |
| DCP (mV) <sup>B</sup>                                     | 100.7    | 97.4     | 99.7     |           |

### Modulation Calibration Parameters

| UID | Communication System Name |   | A<br>dB | B<br>dB/μV | C   | D<br>dB | VR<br>mV | Unc <sup>E</sup><br>(k=2) |
|-----|---------------------------|---|---------|------------|-----|---------|----------|---------------------------|
| 0   | CW                        | X | 0.0     | 0.0        | 1.0 | 0.00    | 178.6    | ±3.0 %                    |
|     |                           | Y | 0.0     | 0.0        | 1.0 |         | 141.9    |                           |
|     |                           | Z | 0.0     | 0.0        | 1.0 |         | 134.7    |                           |

The reported uncertainty of measurement is stated as the standard uncertainty of measurement multiplied by the coverage factor k=2, which for a normal distribution corresponds to a coverage probability of approximately 95%.

<sup>A</sup> The uncertainties of NormX,Y,Z do not affect the E<sup>2</sup>-field uncertainty inside TSL (see Pages 5 and 6).

<sup>B</sup> Numerical linearization parameter: uncertainty not required.

<sup>E</sup> Uncertainty is determined using the max. deviation from linear response applying rectangular distribution and is expressed for the square of the field value.

## DASY/EASY - Parameters of Probe: ES3DV2 - SN:3022

### Calibration Parameter Determined in Head Tissue Simulating Media

| f (MHz) <sup>C</sup> | Relative Permittivity <sup>F</sup> | Conductivity (S/m) <sup>F</sup> | ConvF X | ConvF Y | ConvF Z | Alpha | Depth (mm) | Unct. (k=2) |
|----------------------|------------------------------------|---------------------------------|---------|---------|---------|-------|------------|-------------|
| 750                  | 41.9                               | 0.89                            | 6.21    | 6.21    | 6.21    | 0.19  | 2.37       | ± 12.0 %    |
| 835                  | 41.5                               | 0.90                            | 6.09    | 6.09    | 6.09    | 0.30  | 1.70       | ± 12.0 %    |
| 1750                 | 40.1                               | 1.37                            | 5.19    | 5.19    | 5.19    | 0.65  | 1.23       | ± 12.0 %    |
| 1900                 | 40.0                               | 1.40                            | 5.03    | 5.03    | 5.03    | 0.51  | 1.43       | ± 12.0 %    |
| 2450                 | 39.2                               | 1.80                            | 4.36    | 4.36    | 4.36    | 0.51  | 1.51       | ± 12.0 %    |
| 2600                 | 39.0                               | 1.96                            | 4.16    | 4.16    | 4.16    | 0.74  | 1.29       | ± 12.0 %    |

<sup>C</sup> Frequency validity of ± 100 MHz only applies for DASY v4.4 and higher (see Page 2), else it is restricted to ± 50 MHz. The uncertainty is the RSS of the ConvF uncertainty at calibration frequency and the uncertainty for the indicated frequency band.

<sup>F</sup> At frequencies below 3 GHz, the validity of tissue parameters ( $\epsilon$  and  $\sigma$ ) can be relaxed to ± 10% if liquid compensation formula is applied to measured SAR values. At frequencies above 3 GHz, the validity of tissue parameters ( $\epsilon$  and  $\sigma$ ) is restricted to ± 5%. The uncertainty is the RSS of the ConvF uncertainty for indicated target tissue parameters.

## DASY/EASY - Parameters of Probe: ES3DV2 - SN:3022

### Calibration Parameter Determined in Body Tissue Simulating Media

| f (MHz) <sup>C</sup> | Relative Permittivity <sup>F</sup> | Conductivity (S/m) <sup>F</sup> | ConvF X | ConvF Y | ConvF Z | Alpha | Depth (mm) | Unct. (k=2) |
|----------------------|------------------------------------|---------------------------------|---------|---------|---------|-------|------------|-------------|
| 750                  | 55.5                               | 0.96                            | 5.92    | 5.92    | 5.92    | 0.24  | 1.99       | ± 12.0 %    |
| 835                  | 55.2                               | 0.97                            | 5.91    | 5.91    | 5.91    | 0.29  | 1.85       | ± 12.0 %    |
| 1750                 | 53.4                               | 1.49                            | 4.75    | 4.75    | 4.75    | 0.52  | 1.52       | ± 12.0 %    |
| 1900                 | 53.3                               | 1.52                            | 4.49    | 4.49    | 4.49    | 0.49  | 1.56       | ± 12.0 %    |
| 2450                 | 52.7                               | 1.95                            | 4.01    | 4.01    | 4.01    | 0.70  | 1.02       | ± 12.0 %    |
| 2600                 | 52.5                               | 2.16                            | 3.85    | 3.85    | 3.85    | 0.58  | 0.90       | ± 12.0 %    |

<sup>C</sup> Frequency validity of ± 100 MHz only applies for DASY v4.4 and higher (see Page 2), else it is restricted to ± 50 MHz. The uncertainty is the RSS of the ConvF uncertainty at calibration frequency and the uncertainty for the indicated frequency band.

<sup>F</sup> At frequencies below 3 GHz, the validity of tissue parameters ( $\epsilon$  and  $\sigma$ ) can be relaxed to ± 10% if liquid compensation formula is applied to measured SAR values. At frequencies above 3 GHz, the validity of tissue parameters ( $\epsilon$  and  $\sigma$ ) is restricted to ± 5%. The uncertainty is the RSS of the ConvF uncertainty for indicated target tissue parameters.

### Frequency Response of E-Field (TEM-Cell:ifi110 EXX, Waveguide: R22)

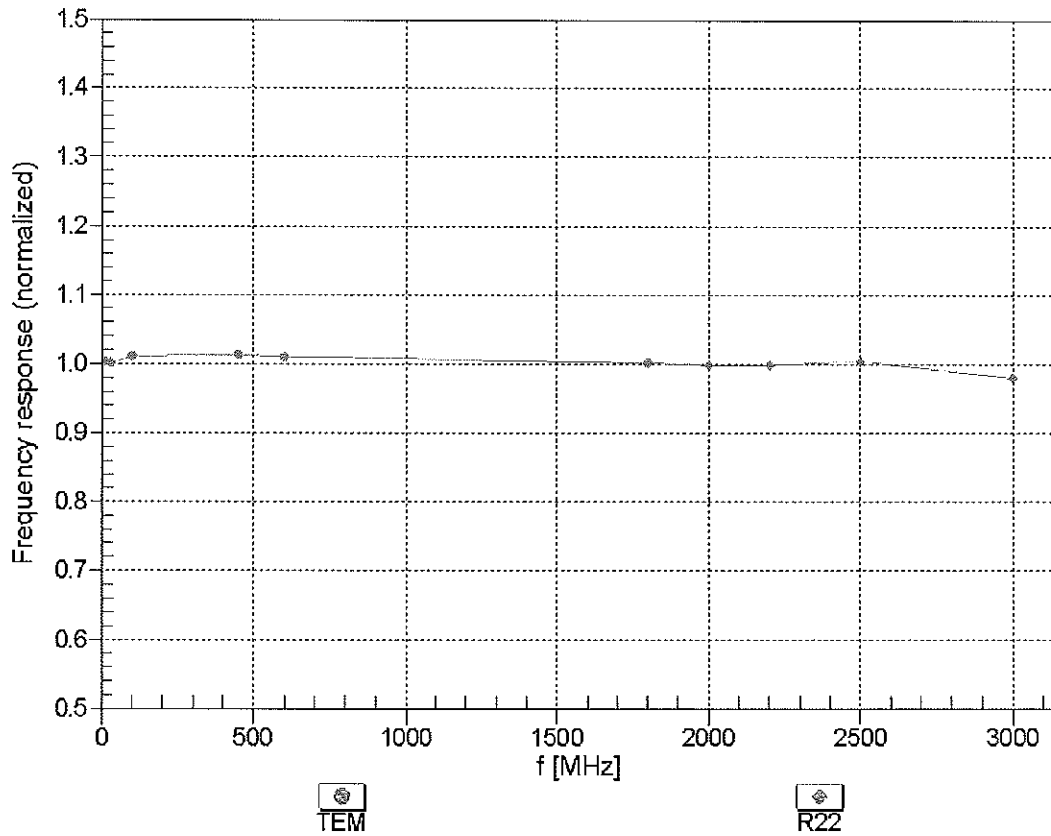

Uncertainty of Frequency Response of E-field:  $\pm 6.3\%$  (k=2)

### Receiving Pattern ( $\phi$ ), $\theta = 0^\circ$

f=600 MHz,TEM

f=1800 MHz,R22

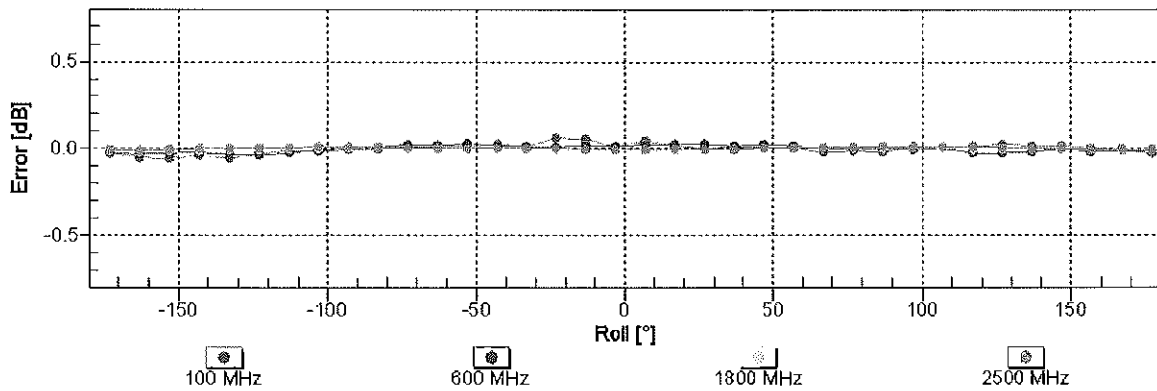
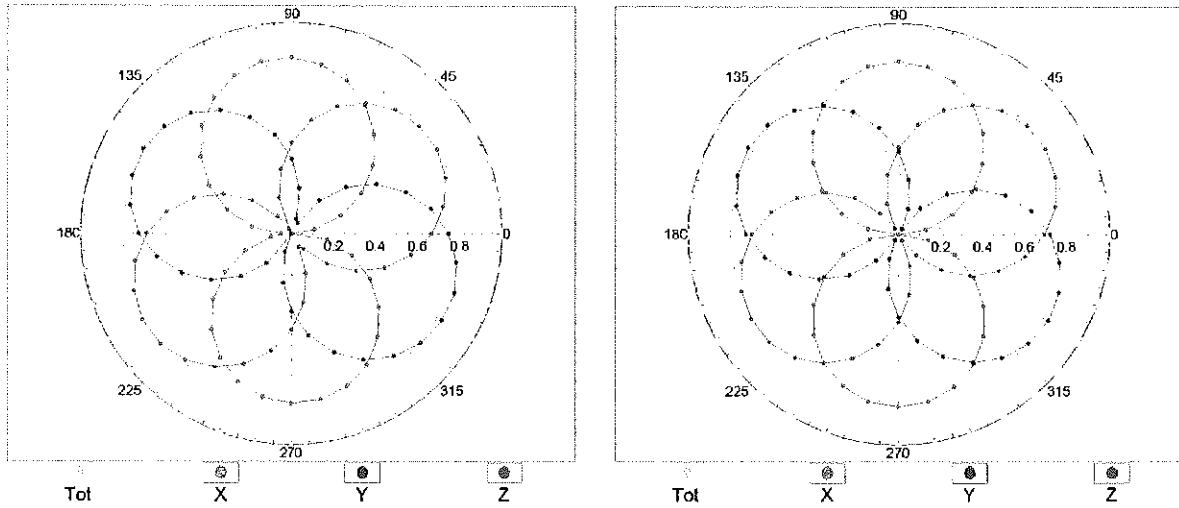

Uncertainty of Axial Isotropy Assessment:  $\pm 0.5\%$  (k=2)

### Dynamic Range f(SAR<sub>head</sub>) (TEM cell , f = 900 MHz)

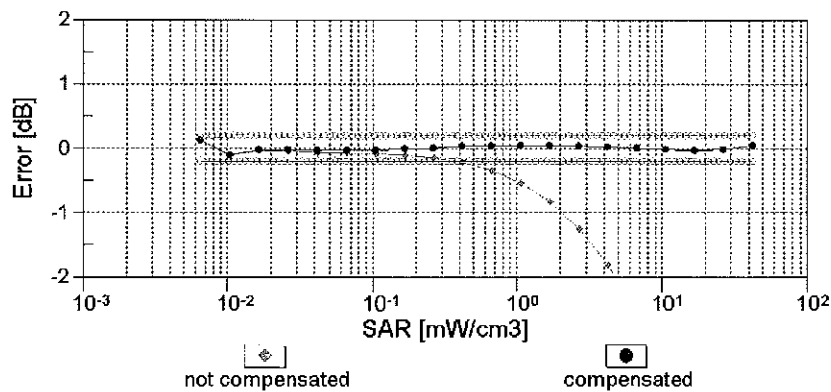
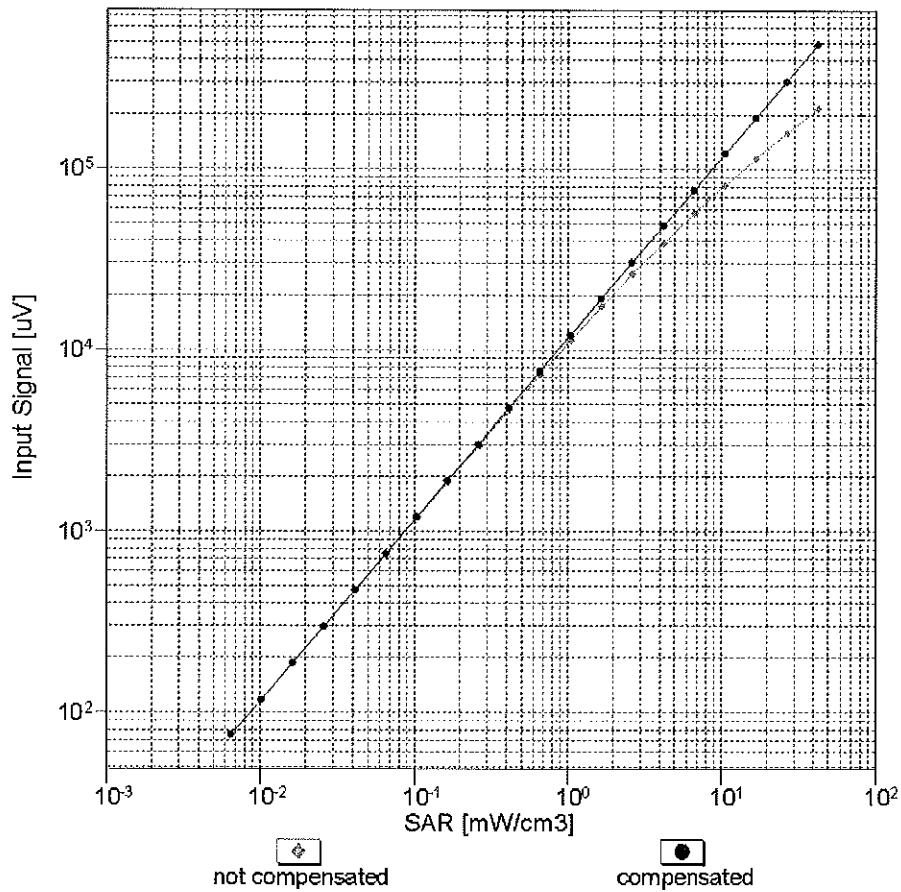

**Uncertainty of Linearity Assessment: ± 0.6% (k=2)**

# Conversion Factor Assessment

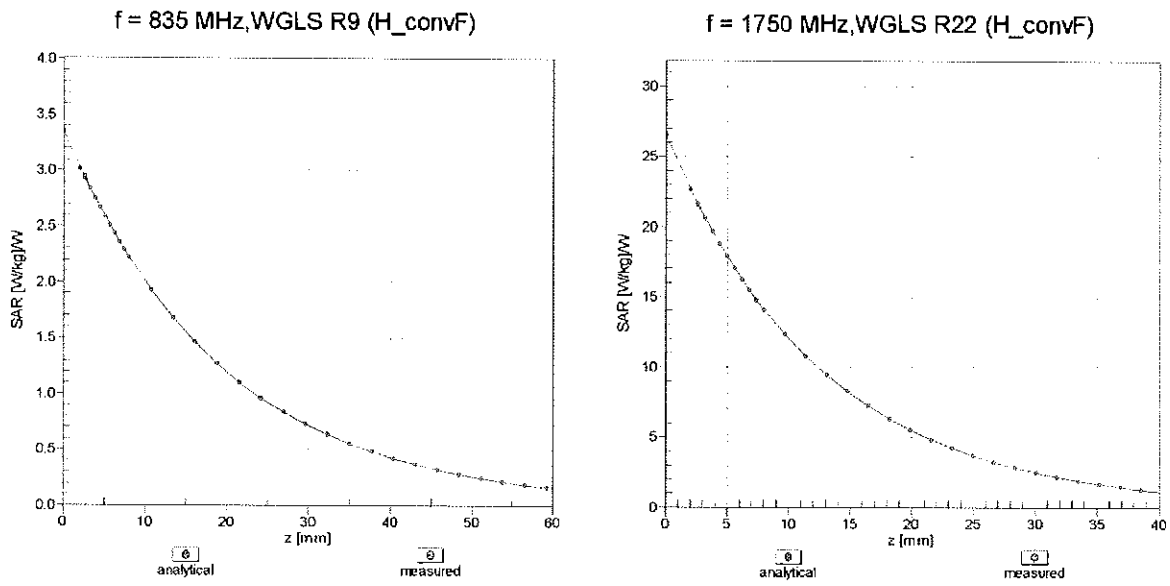

## Deviation from Isotropy in Liquid Error ( $\phi, \theta$ ), $f = 900$ MHz

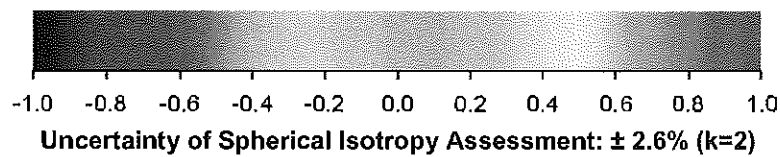
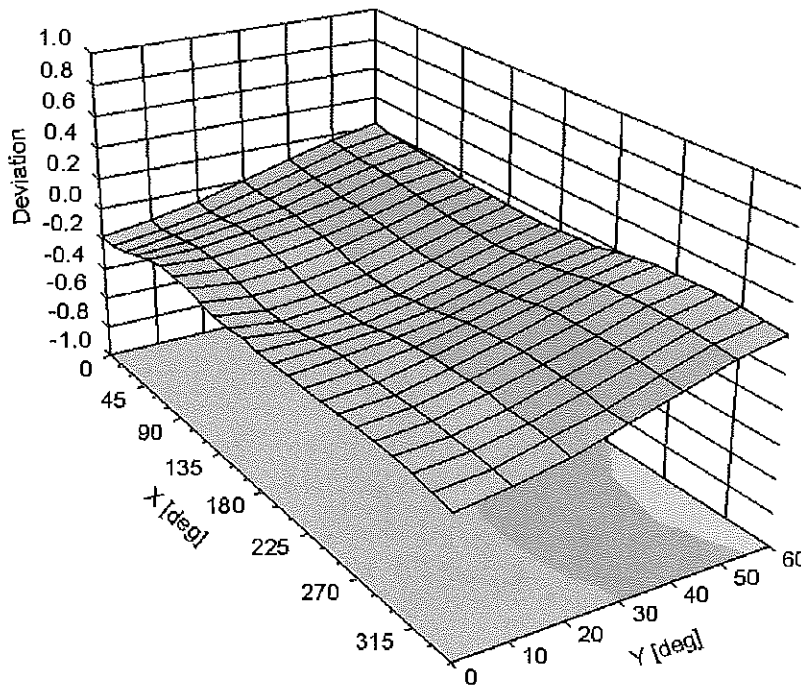

## DASY/EASY - Parameters of Probe: ES3DV2 - SN:3022

### Other Probe Parameters

|   |            |
|---|------------|
| Sensor Arrangement                            | Triangular |
| Connector Angle (°)                           | -83.1      |
| Mechanical Surface Detection Mode             | enabled    |
| Optical Surface Detection Mode                | disabled   |
| Probe Overall Length                          | 337 mm     |
| Probe Body Diameter                           | 10 mm      |
| Tip Length                                    | 10 mm      |
| Tip Diameter                                  | 4 mm       |
| Probe Tip to Sensor X Calibration Point       | 2 mm       |
| Probe Tip to Sensor Y Calibration Point       | 2 mm       |
| Probe Tip to Sensor Z Calibration Point       | 2 mm       |
| Recommended Measurement Distance from Surface | 3 mm       |



Accredited by the Swiss Accreditation Service (SAS)  
The Swiss Accreditation Service is one of the signatories to the EA  
Multilateral Agreement for the recognition of calibration certificates

Accreditation No.: **SCS 108**

Client **PC Test**

Certificate No: **D1900V2-5d148\_Feb13**

## CALIBRATION CERTIFICATE

Object **D1900V2 - SN: 5d148**

Calibration procedure(s) **QA CAL-05.v9  
Calibration procedure for dipole validation kits above 700 MHz**

Calibration date: **February 06, 2013**

*KOK  
2/21/13*

This calibration certificate documents the traceability to national standards, which realize the physical units of measurements (SI).  
The measurements and the uncertainties with confidence probability are given on the following pages and are part of the certificate.

All calibrations have been conducted in the closed laboratory facility: environment temperature ( $22 \pm 3$ )°C and humidity < 70%.

Calibration Equipment used (M&TE critical for calibration)

| Primary Standards           | ID #               | Cal Date (Certificate No.)        | Scheduled Calibration  |
|-----------------------------|--------------------|-----------------------------------|------------------------|
| Power meter EPM-442A        | GB37480704         | 01-Nov-12 (No. 217-01640)         | Oct-13                 |
| Power sensor HP 8481A       | US37292783         | 01-Nov-12 (No. 217-01640)         | Oct-13                 |
| Reference 20 dB Attenuator  | SN: 5058 (20k)     | 27-Mar-12 (No. 217-01530)         | Apr-13                 |
| Type-N mismatch combination | SN: 5047.3 / 06327 | 27-Mar-12 (No. 217-01533)         | Apr-13                 |
| Reference Probe ES3DV3      | SN: 3205           | 28-Dec-12 (No. ES3-3205_Dec12)    | Dec-13                 |
| DAE4                        | SN: 601            | 27-Jun-12 (No. DAE4-601_Jun12)    | Jun-13                 |
| Secondary Standards         | ID #               | Check Date (in house)             | Scheduled Check        |
| Power sensor HP 8481A       | MY41092317         | 18-Oct-02 (in house check Oct-11) | In house check: Oct-13 |
| RF generator R&S SMT-06     | 100005             | 04-Aug-99 (in house check Oct-11) | In house check: Oct-13 |
| Network Analyzer HP 8753E   | US37390585 S4206   | 18-Oct-01 (in house check Oct-12) | In house check: Oct-13 |

|                |               |                       |                      |
|----------------|---------------|-----------------------|----------------------|
|                | <b>Name</b>   | <b>Function</b>       | <b>Signature</b>     |
| Calibrated by: | Leif Klysner  | Laboratory Technician | <i>Leif Klysner</i>  |
| Approved by:   | Katja Pokovic | Technical Manager     | <i>Katja Pokovic</i> |

Issued: February 6, 2013

This calibration certificate shall not be reproduced except in full without written approval of the laboratory.



Accredited by the Swiss Accreditation Service (SAS)

The Swiss Accreditation Service is one of the signatories to the EA Multilateral Agreement for the recognition of calibration certificates

Accreditation No.: **SCS 108**

### Glossary:

|       |                                 |
|-------|---------------------------------|
| TSL   | tissue simulating liquid        |
| ConvF | sensitivity in TSL / NORM x,y,z |
| N/A   | not applicable or not measured  |

### Calibration is Performed According to the Following Standards:

- IEEE Std 1528-2003, "IEEE Recommended Practice for Determining the Peak Spatial-Averaged Specific Absorption Rate (SAR) in the Human Head from Wireless Communications Devices: Measurement Techniques", December 2003
- IEC 62209-1, "Procedure to measure the Specific Absorption Rate (SAR) for hand-held devices used in close proximity to the ear (frequency range of 300 MHz to 3 GHz)", February 2005
- Federal Communications Commission Office of Engineering & Technology (FCC OET), "Evaluating Compliance with FCC Guidelines for Human Exposure to Radiofrequency Electromagnetic Fields; Additional Information for Evaluating Compliance of Mobile and Portable Devices with FCC Limits for Human Exposure to Radiofrequency Emissions", Supplement C (Edition 01-01) to Bulletin 65

### Additional Documentation:

- DASY4/5 System Handbook

### Methods Applied and Interpretation of Parameters:

- Measurement Conditions:* Further details are available from the Validation Report at the end of the certificate. All figures stated in the certificate are valid at the frequency indicated.
- Antenna Parameters with TSL:* The dipole is mounted with the spacer to position its feed point exactly below the center marking of the flat phantom section, with the arms oriented parallel to the body axis.
- Feed Point Impedance and Return Loss:* These parameters are measured with the dipole positioned under the liquid filled phantom. The impedance stated is transformed from the measurement at the SMA connector to the feed point. The Return Loss ensures low reflected power. No uncertainty required.
- Electrical Delay:* One-way delay between the SMA connector and the antenna feed point. No uncertainty required.
- SAR measured:* SAR measured at the stated antenna input power.
- SAR normalized:* SAR as measured, normalized to an input power of 1 W at the antenna connector.
- SAR for nominal TSL parameters:* The measured TSL parameters are used to calculate the nominal SAR result.

The reported uncertainty of measurement is stated as the standard uncertainty of measurement multiplied by the coverage factor  $k=2$ , which for a normal distribution corresponds to a coverage probability of approximately 95%.

## Measurement Conditions

DASY system configuration, as far as not given on page 1.

|                                     |                        |             |
|-------------------------------------|------------------------|-------------|
| <b>DASY Version</b>                 | DASY5                  | V52.8.5     |
| <b>Extrapolation</b>                | Advanced Extrapolation |             |
| <b>Phantom</b>                      | Modular Flat Phantom   |             |
| <b>Distance Dipole Center - TSL</b> | 10 mm                  | with Spacer |
| <b>Zoom Scan Resolution</b>         | dx, dy, dz = 5 mm      |             |
| <b>Frequency</b>                    | 1900 MHz $\pm$ 1 MHz   |             |

## Head TSL parameters

The following parameters and calculations were applied.

|  | Temperature         | Permittivity   | Conductivity         |
|--|---------------------|----------------|----------------------|
| <b>Nominal Head TSL parameters</b>             | 22.0 °C             | 40.0           | 1.40 mho/m           |
| <b>Measured Head TSL parameters</b>            | (22.0 $\pm$ 0.2) °C | 39.4 $\pm$ 6 % | 1.38 mho/m $\pm$ 6 % |
| <b>Head TSL temperature change during test</b> | < 0.5 °C            | ----           | ----                 |

## SAR result with Head TSL

| <b>SAR averaged over 1 cm<sup>3</sup> (1 g) of Head TSL</b> | Condition          |  |
|---|--------------------|--|
| SAR measured  | 250 mW input power | 9.87 W/kg                                      |
| SAR for nominal Head TSL parameters                         | normalized to 1W   | <b>39.7 W/kg <math>\pm</math> 17.0 % (k=2)</b> |

| <b>SAR averaged over 10 cm<sup>3</sup> (10 g) of Head TSL</b> | condition          |  |
|---|--------------------|--|
| SAR measured  | 250 mW input power | 5.18 W/kg                                      |
| SAR for nominal Head TSL parameters                           | normalized to 1W   | <b>20.8 W/kg <math>\pm</math> 16.5 % (k=2)</b> |

## Body TSL parameters

The following parameters and calculations were applied.

|  | Temperature         | Permittivity   | Conductivity         |
|--|---------------------|----------------|----------------------|
| <b>Nominal Body TSL parameters</b>             | 22.0 °C             | 53.3           | 1.52 mho/m           |
| <b>Measured Body TSL parameters</b>            | (22.0 $\pm$ 0.2) °C | 51.9 $\pm$ 6 % | 1.53 mho/m $\pm$ 6 % |
| <b>Body TSL temperature change during test</b> | < 0.5 °C            | ----           | ----                 |

## SAR result with Body TSL

| <b>SAR averaged over 1 cm<sup>3</sup> (1 g) of Body TSL</b> | Condition          |  |
|---|--------------------|--|
| SAR measured  | 250 mW input power | 10.3 W/kg                                      |
| SAR for nominal Body TSL parameters                         | normalized to 1W   | <b>40.8 W/kg <math>\pm</math> 17.0 % (k=2)</b> |

| <b>SAR averaged over 10 cm<sup>3</sup> (10 g) of Body TSL</b> | condition          |  |
|---|--------------------|--|
| SAR measured  | 250 mW input power | 5.45 W/kg                                      |
| SAR for nominal Body TSL parameters                           | normalized to 1W   | <b>21.7 W/kg <math>\pm</math> 16.5 % (k=2)</b> |

## Appendix

### Antenna Parameters with Head TSL

|                                      |                                |
|--------------------------------------|--------------------------------|
| Impedance, transformed to feed point | 52.1 $\Omega$ + 5.9 j $\Omega$ |
| Return Loss                          | - 24.3 dB                      |

### Antenna Parameters with Body TSL

|                                      |                                |
|--------------------------------------|--------------------------------|
| Impedance, transformed to feed point | 48.3 $\Omega$ + 6.3 j $\Omega$ |
| Return Loss                          | - 23.6 dB                      |

### General Antenna Parameters and Design

|                                  |          |
|----------------------------------|----------|
| Electrical Delay (one direction) | 1.199 ns |
|----------------------------------|----------|

After long term use with 100W radiated power, only a slight warming of the dipole near the feedpoint can be measured.

The dipole is made of standard semirigid coaxial cable. The center conductor of the feeding line is directly connected to the second arm of the dipole. The antenna is therefore short-circuited for DC-signals. On some of the dipoles, small end caps are added to the dipole arms in order to improve matching when loaded according to the position as explained in the "Measurement Conditions" paragraph. The SAR data are not affected by this change. The overall dipole length is still according to the Standard.

No excessive force must be applied to the dipole arms, because they might bend or the soldered connections near the feedpoint may be damaged.

### Additional EUT Data

|                 |                |
|-----------------|----------------|
| Manufactured by | SPEAG          |
| Manufactured on | March 11, 2011 |

## DASY5 Validation Report for Head TSL

Date: 06.02.2013

Test Laboratory: SPEAG, Zurich, Switzerland

**DUT: Dipole 1900 MHz; Type: D1900V2; Serial: D1900V2 - SN: 5d148**

Communication System: CW; Frequency: 1900 MHz

Medium parameters used:  $f = 1900$  MHz;  $\sigma = 1.38$  S/m;  $\epsilon_r = 39.4$ ;  $\rho = 1000$  kg/m<sup>3</sup>

Phantom section: Flat Section

Measurement Standard: DASY5 (IEEE/IEC/ANSI C63.19-2007)

DASY52 Configuration:

- Probe: ES3DV3 - SN3205; ConvF(4.98, 4.98, 4.98); Calibrated: 28.12.2012;
- Sensor-Surface: 3mm (Mechanical Surface Detection)
- Electronics: DAE4 Sn601; Calibrated: 27.06.2012
- Phantom: Flat Phantom 5.0 (front); Type: QD000P50AA; Serial: 1001
- DASY52 52.8.5(1059); SEMCAD X 14.6.8(7028)

### **Dipole Calibration for Head Tissue/Pin=250 mW, d=10mm/Zoom Scan (7x7x7)/Cube 0:**

Measurement grid: dx=5mm, dy=5mm, dz=5mm

Reference Value = 96.534 V/m; Power Drift = 0.05 dB

Peak SAR (extrapolated) = 17.8 W/kg

**SAR(1 g) = 9.87 W/kg; SAR(10 g) = 5.18 W/kg**

Maximum value of SAR (measured) = 12.1 W/kg

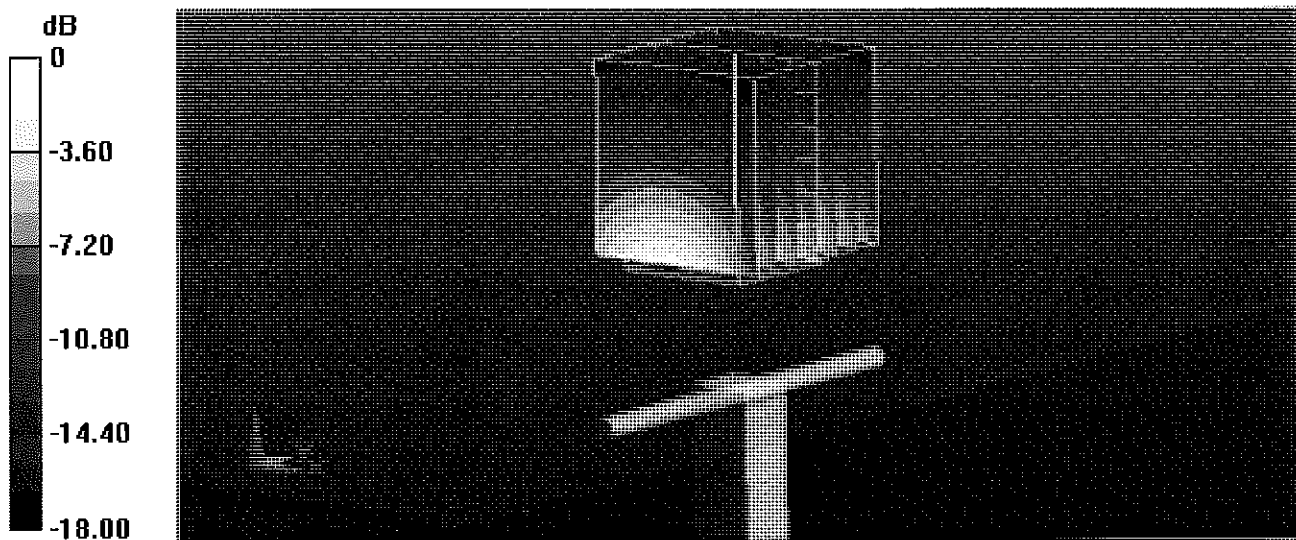

0 dB = 12.1 W/kg = 10.83 dBW/kg

# Impedance Measurement Plot for Head TSL

6 Feb 2013 09:25:10

CH1 S11 1 U FS

1: 52.125  $\Omega$  5.8711  $\Omega$  491.80  $\mu$ H

1 900.000 000 MHz

\*  
Del  
CA  
Avg  
16  
H1d

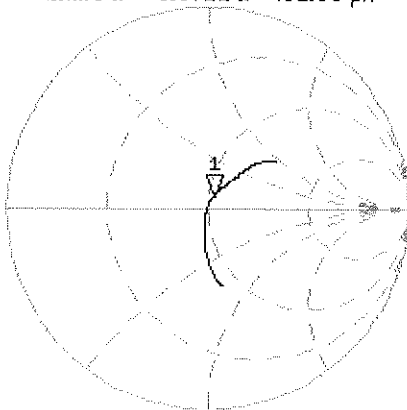

CH2 S11 LOG

5 dB/REF -20 dB

1: -24.287 dB 1 900.000 000 MHz

CA  
Avg  
16  
H1d

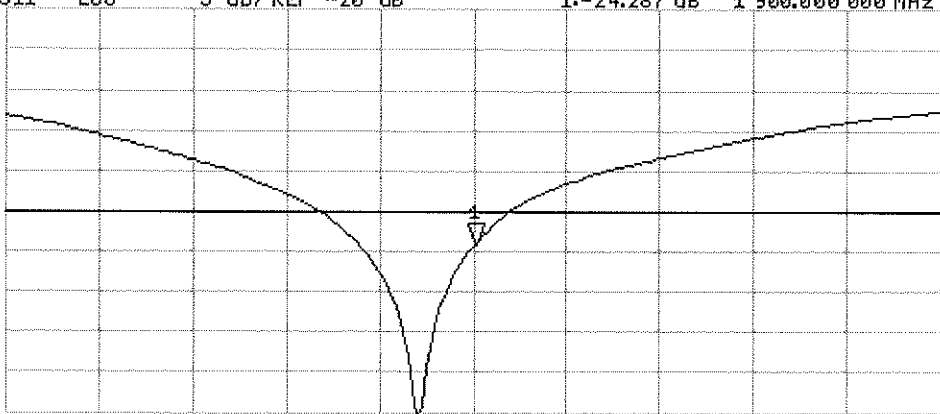

START 1 700.000 000 MHz

STOP 2 100.000 000 MHz

## DASY5 Validation Report for Body TSL

Date: 06.02.2013

Test Laboratory: SPEAG, Zurich, Switzerland

**DUT: Dipole 1900 MHz; Type: D1900V2; Serial: D1900V2 - SN: 5d148**

Communication System: CW; Frequency: 1900 MHz

Medium parameters used:  $f = 1900$  MHz;  $\sigma = 1.53$  S/m;  $\epsilon_r = 51.9$ ;  $\rho = 1000$  kg/m<sup>3</sup>

Phantom section: Flat Section

Measurement Standard: DASY5 (IEEE/IEC/ANSI C63.19-2007)

DASY52 Configuration:

- Probe: ES3DV3 - SN3205; ConvF(4.6, 4.6, 4.6); Calibrated: 28.12.2012;
- Sensor-Surface: 3mm (Mechanical Surface Detection)
- Electronics: DAE4 Sn601; Calibrated: 27.06.2012
- Phantom: Flat Phantom 5.0 (back); Type: QD000P50AA; Serial: 1002
- DASY52 52.8.5(1059); SEMCAD X 14.6.8(7028)

### Dipole Calibration for Body Tissue/Pin=250 mW, d=10mm/Zoom Scan (7x7x7)/Cube 0:

Measurement grid: dx=5mm, dy=5mm, dz=5mm

Reference Value = 96.534 V/m; Power Drift = -0.02 dB

Peak SAR (extrapolated) = 17.9 W/kg

**SAR(1 g) = 10.3 W/kg; SAR(10 g) = 5.45 W/kg**

Maximum value of SAR (measured) = 13.1 W/kg

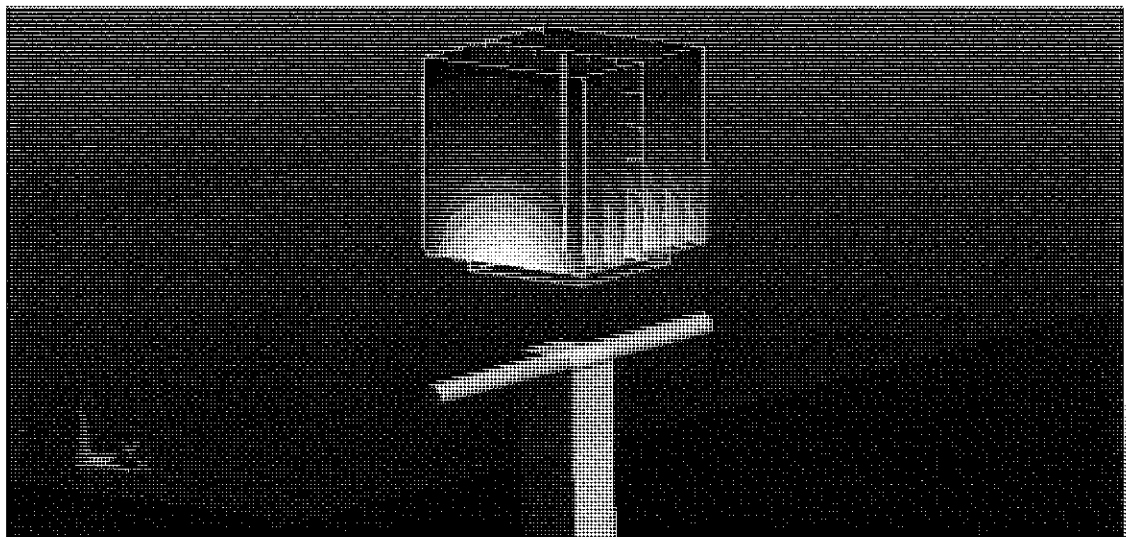
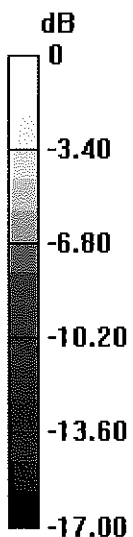

0 dB = 13.1 W/kg = 11.17 dBW/kg

# Impedance Measurement Plot for Body TSL

6 Feb 2013 09:24:17

CH1 S11 1 U FS 1: 48.344  $\Omega$  6.2715  $\Omega$  525.34  $\mu$ H 1 900.000 000 MHz

\*  
De1

CA

Avg  
16

H1d

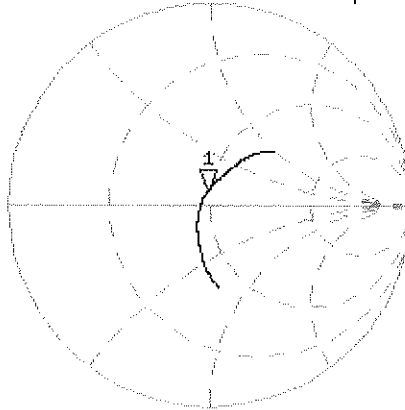

CH2 S11 LOG 5 dB/REF -20 dB 1:-23.628 dB 1 900.000 000 MHz

CA

Avg  
16

H1d

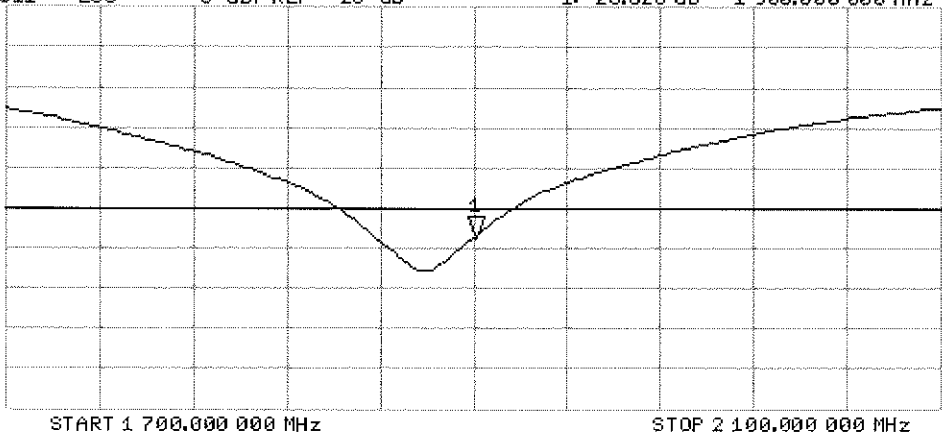

**Calibration Laboratory of  
Schmid & Partner  
Engineering AG**  
Zeughausstrasse 43, 8004 Zurich, Switzerland



**S  
C  
S** Schweizerischer Kalibrierdienst  
Service suisse d'étalonnage  
Servizio svizzero di taratura  
Swiss Calibration Service

Accredited by the Swiss Accreditation Service (SAS)  
The Swiss Accreditation Service is one of the signatories to the EA  
Multilateral Agreement for the recognition of calibration certificates

Accreditation No.: **SCS 108**

Client **PC Test**

Certificate No: **ES3-3209\_Mar13**

**CALIBRATION CERTIFICATE**

Object **ES3DV3 - SN:3209**

Calibration procedure(s) **QA CAL-01.v8, QA CAL-23.v4, QA CAL-25.v4  
Calibration procedure for dosimetric E-field probes**

Calibration date: **March 15, 2013**

This calibration certificate documents the traceability to national standards, which realize the physical units of measurements (SI).  
The measurements and the uncertainties with confidence probability are given on the following pages and are part of the certificate.

All calibrations have been conducted in the closed laboratory facility: environment temperature (22 ± 3)°C and humidity < 70%.

*✓ KOK  
3/22/13*

Calibration Equipment used (M&TE critical for calibration)

| Primary Standards          | ID              | Cal Date (Certificate No.)        | Scheduled Calibration  |
|----------------------------|-----------------|-----------------------------------|------------------------|
| Power meter E4419B         | GB41293874      | 29-Mar-12 (No. 217-01508)         | Apr-13                 |
| Power sensor E4412A        | MY41498087      | 29-Mar-12 (No. 217-01508)         | Apr-13                 |
| Reference 3 dB Attenuator  | SN: S5054 (3c)  | 27-Mar-12 (No. 217-01531)         | Apr-13                 |
| Reference 20 dB Attenuator | SN: S5086 (20b) | 27-Mar-12 (No. 217-01529)         | Apr-13                 |
| Reference 30 dB Attenuator | SN: S5129 (30b) | 27-Mar-12 (No. 217-01532)         | Apr-13                 |
| Reference Probe ES3DV2     | SN: 3013        | 28-Dec-12 (No. ES3-3013_Dec12)    | Dec-13                 |
| DAE4                       | SN: 660         | 31-Jan-13 (No. DAE4-660_Jan13)    | Jan-14                 |
| Secondary Standards        | ID              | Check Date (in house)             | Scheduled Check        |
| RF generator HP 8648C      | US3642U01700    | 4-Aug-99 (in house check Apr-11)  | In house check: Apr-13 |
| Network Analyzer HP 8753E  | US37390585      | 18-Oct-01 (in house check Oct-12) | In house check: Oct-13 |

|                | Name           | Function              | Signature             |
|----------------|----------------|-----------------------|-----------------------|
| Calibrated by: | Israe El-Naouq | Laboratory Technician | <i>Israe El-Naouq</i> |
| Approved by:   | Katja Pokovic  | Technical Manager     | <i>Katja Pokovic</i>  |

Issued: March 15, 2013

This calibration certificate shall not be reproduced except in full without written approval of the laboratory.

80242



Accredited by the Swiss Accreditation Service (SAS)

Accreditation No.: **SCS 108**

The Swiss Accreditation Service is one of the signatories to the EA  
 Multilateral Agreement for the recognition of calibration certificates

**Glossary:**

|                       |   |
|-----------------------|---|
| TSL                   | tissue simulating liquid  |
| NORM <sub>x,y,z</sub> | sensitivity in free space   |
| ConvF                 | sensitivity in TSL / NORM <sub>x,y,z</sub>  |
| DCP                   | diode compression point   |
| CF                    | crest factor (1/duty_cycle) of the RF signal  |
| A, B, C, D            | modulation dependent linearization parameters   |
| Polarization φ        | φ rotation around probe axis  |
| Polarization ϑ        | ϑ rotation around an axis that is in the plane normal to probe axis (at measurement center),<br>i.e., ϑ = 0 is normal to probe axis |

**Calibration is Performed According to the Following Standards:**

- a) IEEE Std 1528-2003, "IEEE Recommended Practice for Determining the Peak Spatial-Averaged Specific Absorption Rate (SAR) in the Human Head from Wireless Communications Devices: Measurement Techniques", December 2003
- b) IEC 62209-1, "Procedure to measure the Specific Absorption Rate (SAR) for hand-held devices used in close proximity to the ear (frequency range of 300 MHz to 3 GHz)", February 2005

**Methods Applied and Interpretation of Parameters:**

- NORM<sub>x,y,z</sub>: Assessed for E-field polarization ϑ = 0 (f ≤ 900 MHz in TEM-cell; f > 1800 MHz: R22 waveguide). NORM<sub>x,y,z</sub> are only intermediate values, i.e., the uncertainties of NORM<sub>x,y,z</sub> does not affect the E<sup>2</sup>-field uncertainty inside TSL (see below ConvF).
- NORM(f)<sub>x,y,z</sub> = NORM<sub>x,y,z</sub> \* frequency\_response (see Frequency Response Chart). This linearization is implemented in DASY4 software versions later than 4.2. The uncertainty of the frequency response is included in the stated uncertainty of ConvF.
- DCP<sub>x,y,z</sub>: DCP are numerical linearization parameters assessed based on the data of power sweep with CW signal (no uncertainty required). DCP does not depend on frequency nor media.
- PAR: PAR is the Peak to Average Ratio that is not calibrated but determined based on the signal characteristics
- Ax,y,z; Bx,y,z; Cx,y,z; Dx,y,z; VRx,y,z; A, B, C, D are numerical linearization parameters assessed based on the data of power sweep for specific modulation signal. The parameters do not depend on frequency nor media. VR is the maximum calibration range expressed in RMS voltage across the diode.
- ConvF and Boundary Effect Parameters: Assessed in flat phantom using E-field (or Temperature Transfer Standard for f ≤ 800 MHz) and inside waveguide using analytical field distributions based on power measurements for f > 800 MHz. The same setups are used for assessment of the parameters applied for boundary compensation (alpha, depth) of which typical uncertainty values are given. These parameters are used in DASY4 software to improve probe accuracy close to the boundary. The sensitivity in TSL corresponds to NORM<sub>x,y,z</sub> \* ConvF whereby the uncertainty corresponds to that given for ConvF. A frequency dependent ConvF is used in DASY version 4.4 and higher which allows extending the validity from ± 50 MHz to ± 100 MHz.
- Spherical isotropy (3D deviation from isotropy): in a field of low gradients realized using a flat phantom exposed by a patch antenna.
- Sensor Offset: The sensor offset corresponds to the offset of virtual measurement center from the probe tip (on probe axis). No tolerance required.

# Probe ES3DV3

## SN:3209

Manufactured: October 14, 2008  
Calibrated: March 15, 2013

Calibrated for DASY/EASY Systems  
(Note: non-compatible with DASY2 system!)

## DASY/EASY - Parameters of Probe: ES3DV3 - SN:3209

### Basic Calibration Parameters

|   | Sensor X | Sensor Y | Sensor Z | Unc (k=2)     |
|---|----------|----------|----------|---------------|
| Norm ( $\mu\text{V}/(\text{V}/\text{m})^2$ ) <sup>A</sup> | 1.35     | 1.33     | 1.14     | $\pm 10.1 \%$ |
| DCP (mV) <sup>B</sup>                                     | 99.2     | 97.8     | 98.3     |               |

### Modulation Calibration Parameters

| UID | Communication System Name |   | A<br>dB | B<br>dB $\sqrt{\mu\text{V}}$ | C   | D<br>dB | VR<br>mV | Unc <sup>E</sup><br>(k=2) |
|-----|---------------------------|---|---------|------------------------------|-----|---------|----------|---------------------------|
| 0   | CW                        | X | 0.0     | 0.0                          | 1.0 | 0.00    | 163.6    | $\pm 3.5 \%$              |
|     |                           | Y | 0.0     | 0.0                          | 1.0 |         | 170.3    |                           |
|     |                           | Z | 0.0     | 0.0                          | 1.0 |         | 158.7    |                           |

The reported uncertainty of measurement is stated as the standard uncertainty of measurement multiplied by the coverage factor  $k=2$ , which for a normal distribution corresponds to a coverage probability of approximately 95%.

<sup>A</sup> The uncertainties of NormX,Y,Z do not affect the  $E^2$ -field uncertainty inside TSL (see Pages 5 and 6).

<sup>B</sup> Numerical linearization parameter: uncertainty not required.

<sup>E</sup> Uncertainty is determined using the max. deviation from linear response applying rectangular distribution and is expressed for the square of the field value.

## DASY/EASY - Parameters of Probe: ES3DV3 - SN:3209

### Calibration Parameter Determined in Head Tissue Simulating Media

| f (MHz) <sup>C</sup> | Relative Permittivity <sup>F</sup> | Conductivity (S/m) <sup>F</sup> | ConvF X | ConvF Y | ConvF Z | Alpha | Depth (mm) | Unct. (k=2) |
|----------------------|------------------------------------|---------------------------------|---------|---------|---------|-------|------------|-------------|
| 750                  | 41.9                               | 0.89                            | 6.74    | 6.74    | 6.74    | 0.76  | 1.18       | ± 12.0 %    |
| 835                  | 41.5                               | 0.90                            | 6.46    | 6.46    | 6.46    | 0.31  | 1.81       | ± 12.0 %    |
| 1750                 | 40.1                               | 1.37                            | 5.39    | 5.39    | 5.39    | 0.80  | 1.21       | ± 12.0 %    |
| 1900                 | 40.0                               | 1.40                            | 5.21    | 5.21    | 5.21    | 0.78  | 1.26       | ± 12.0 %    |
| 2450                 | 39.2                               | 1.80                            | 4.57    | 4.57    | 4.57    | 0.65  | 1.43       | ± 12.0 %    |
| 2600                 | 39.0                               | 1.96                            | 4.43    | 4.43    | 4.43    | 0.75  | 1.36       | ± 12.0 %    |

<sup>C</sup> Frequency validity of ± 100 MHz only applies for DASY v4.4 and higher (see Page 2), else it is restricted to ± 50 MHz. The uncertainty is the RSS of the ConvF uncertainty at calibration frequency and the uncertainty for the indicated frequency band.

<sup>F</sup> At frequencies below 3 GHz, the validity of tissue parameters ( $\epsilon$  and  $\sigma$ ) can be relaxed to ± 10% if liquid compensation formula is applied to measured SAR values. At frequencies above 3 GHz, the validity of tissue parameters ( $\epsilon$  and  $\sigma$ ) is restricted to ± 5%. The uncertainty is the RSS of the ConvF uncertainty for indicated target tissue parameters.

## DASY/EASY - Parameters of Probe: ES3DV3 - SN:3209

### Calibration Parameter Determined in Body Tissue Simulating Media

| f (MHz) <sup>C</sup> | Relative Permittivity <sup>F</sup> | Conductivity (S/m) <sup>F</sup> | ConvF X | ConvF Y | ConvF Z | Alpha | Depth (mm) | Unct. (k=2) |
|----------------------|------------------------------------|---------------------------------|---------|---------|---------|-------|------------|-------------|
| 750                  | 55.5                               | 0.96                            | 6.38    | 6.38    | 6.38    | 0.80  | 1.16       | ± 12.0 %    |
| 835                  | 55.2                               | 0.97                            | 6.28    | 6.28    | 6.28    | 0.52  | 1.45       | ± 12.0 %    |
| 1750                 | 53.4                               | 1.49                            | 5.03    | 5.03    | 5.03    | 0.58  | 1.45       | ± 12.0 %    |
| 1900                 | 53.3                               | 1.52                            | 4.77    | 4.77    | 4.77    | 0.70  | 1.36       | ± 12.0 %    |
| 2450                 | 52.7                               | 1.95                            | 4.34    | 4.34    | 4.34    | 0.80  | 1.15       | ± 12.0 %    |
| 2600                 | 52.5                               | 2.16                            | 4.11    | 4.11    | 4.11    | 0.80  | 1.00       | ± 12.0 %    |

<sup>C</sup> Frequency validity of ± 100 MHz only applies for DASY v4.4 and higher (see Page 2), else it is restricted to ± 50 MHz. The uncertainty is the RSS of the ConvF uncertainty at calibration frequency and the uncertainty for the indicated frequency band.

<sup>F</sup> At frequencies below 3 GHz, the validity of tissue parameters ( $\epsilon$  and  $\sigma$ ) can be relaxed to ± 10% if liquid compensation formula is applied to measured SAR values. At frequencies above 3 GHz, the validity of tissue parameters ( $\epsilon$  and  $\sigma$ ) is restricted to ± 5%. The uncertainty is the RSS of the ConvF uncertainty for indicated target tissue parameters.

# Frequency Response of E-Field (TEM-Cell:ifi110 EXX, Waveguide: R22)

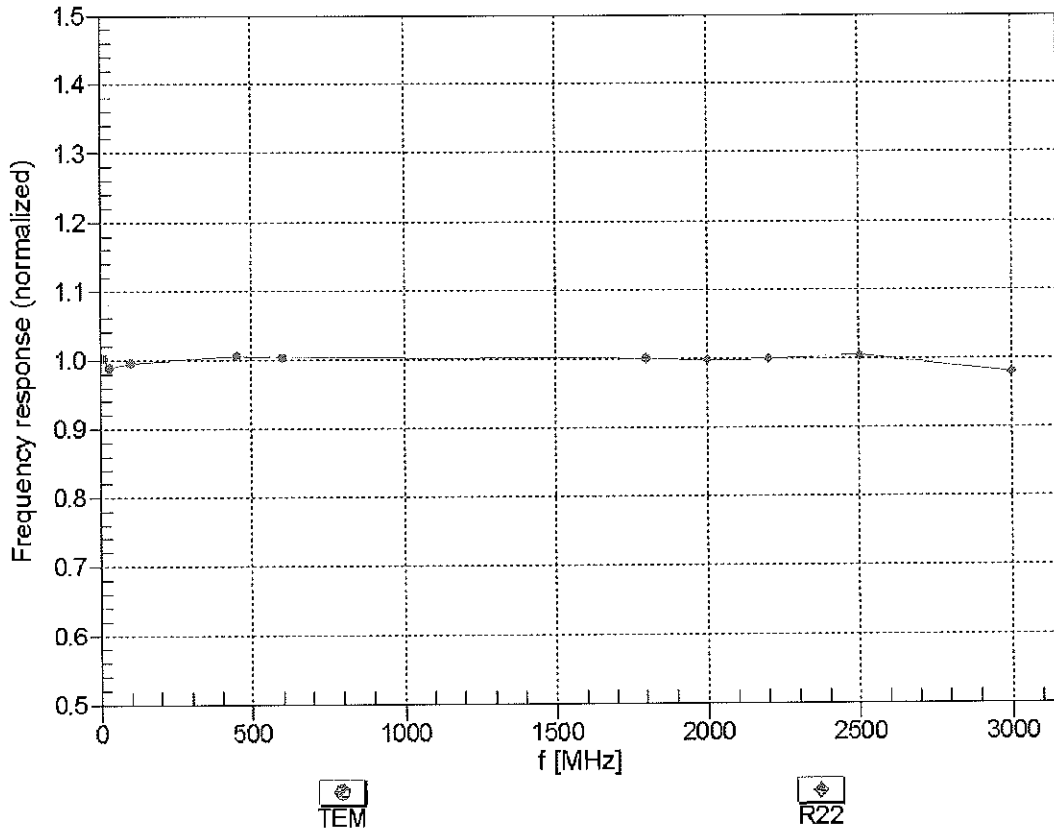

Uncertainty of Frequency Response of E-field:  $\pm 6.3\%$  (k=2)

### Receiving Pattern ( $\phi$ ), $\theta = 0^\circ$

f=600 MHz,TEM

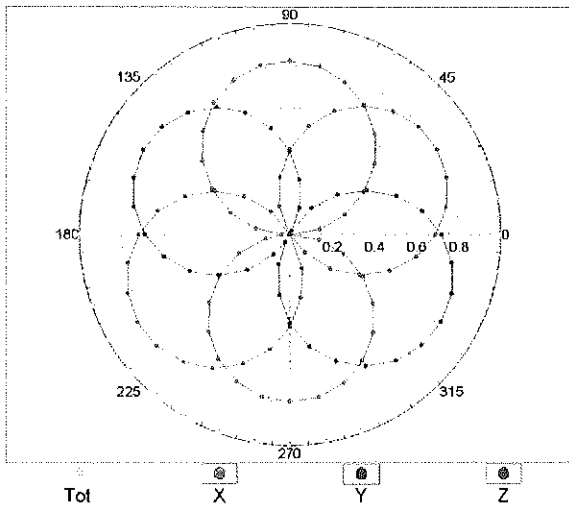

f=1800 MHz,R22

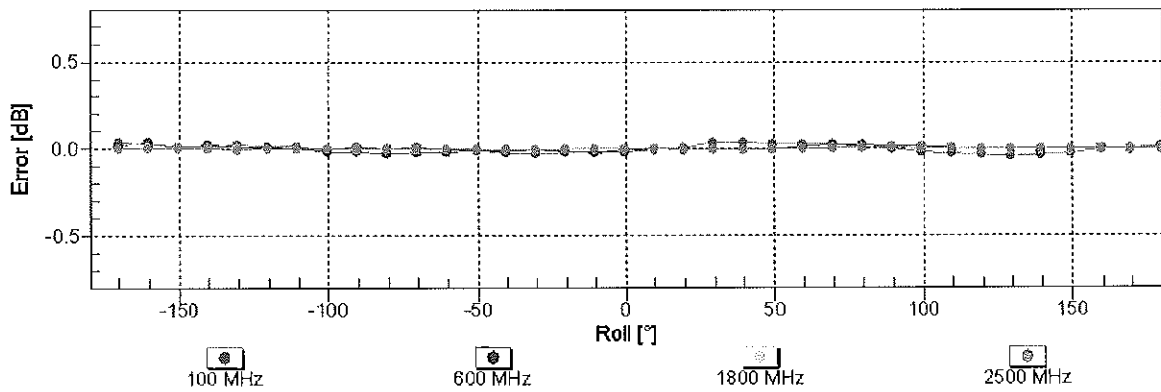
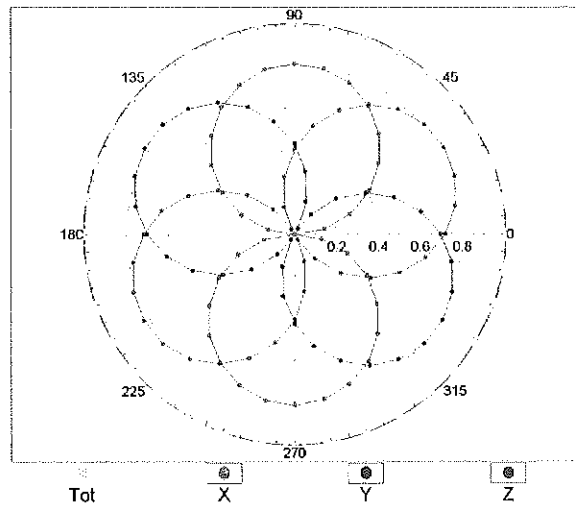

Uncertainty of Axial Isotropy Assessment:  $\pm 0.5\%$  (k=2)

## Dynamic Range $f(\text{SAR}_{\text{head}})$ (TEM cell , $f = 900 \text{ MHz}$ )

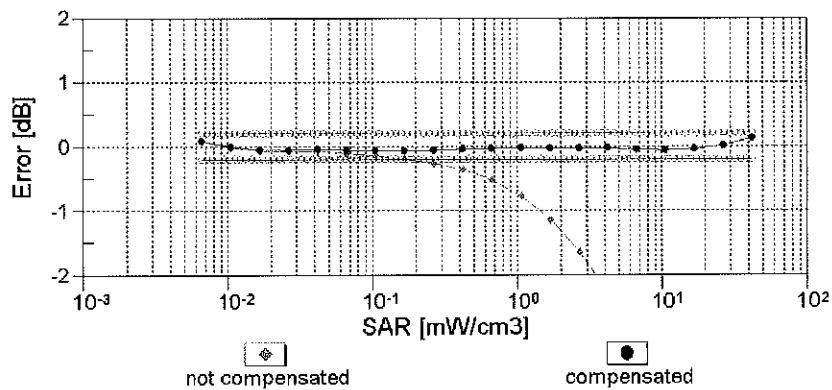
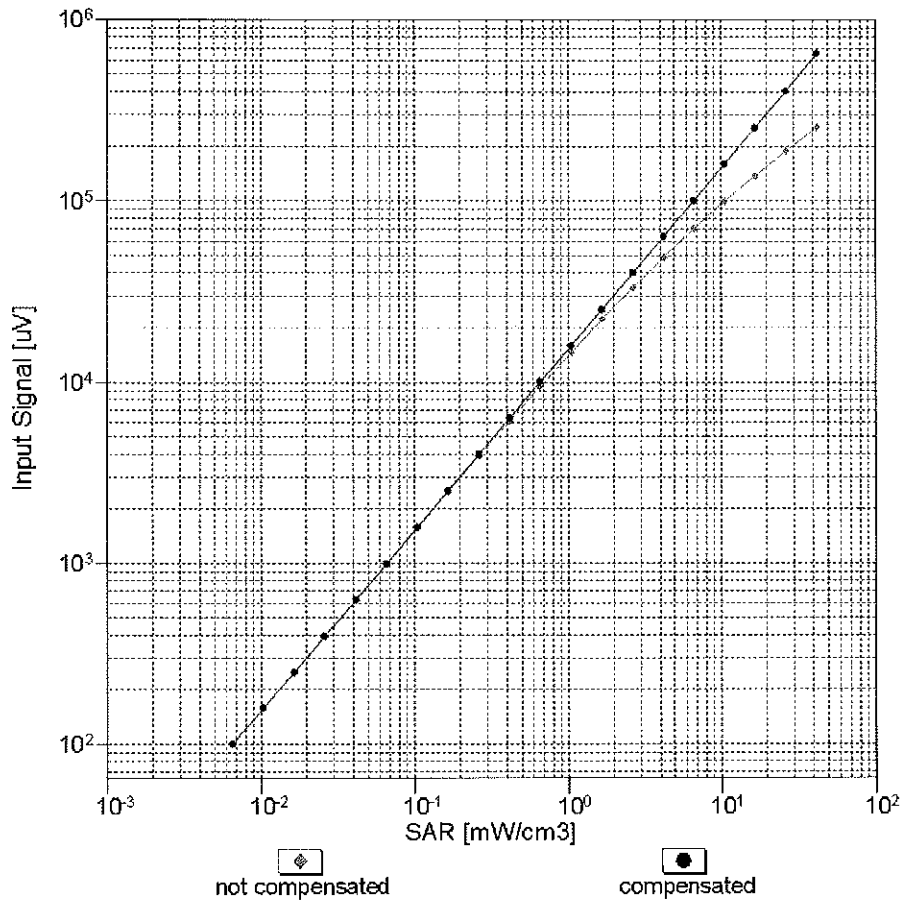

**Uncertainty of Linearity Assessment:  $\pm 0.6\%$  ( $k=2$ )**

# Conversion Factor Assessment

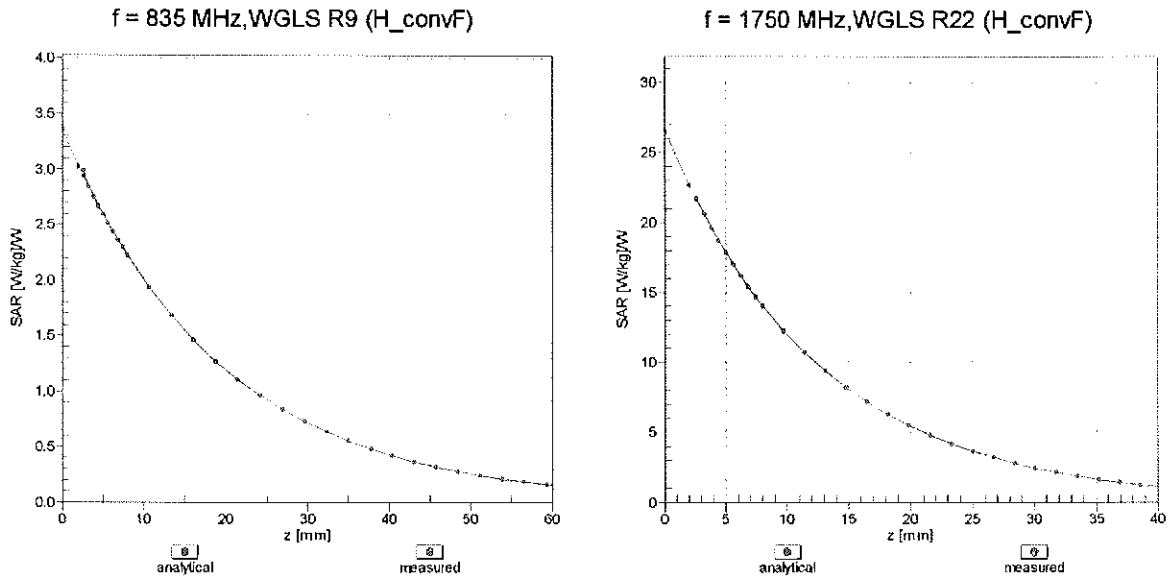

## Deviation from Isotropy in Liquid Error ( $\phi, \theta$ ), f = 900 MHz

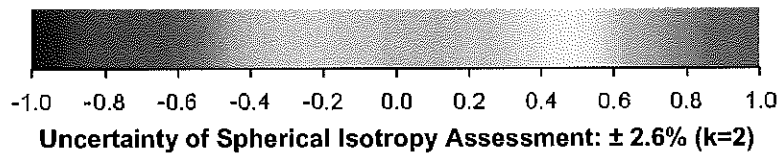
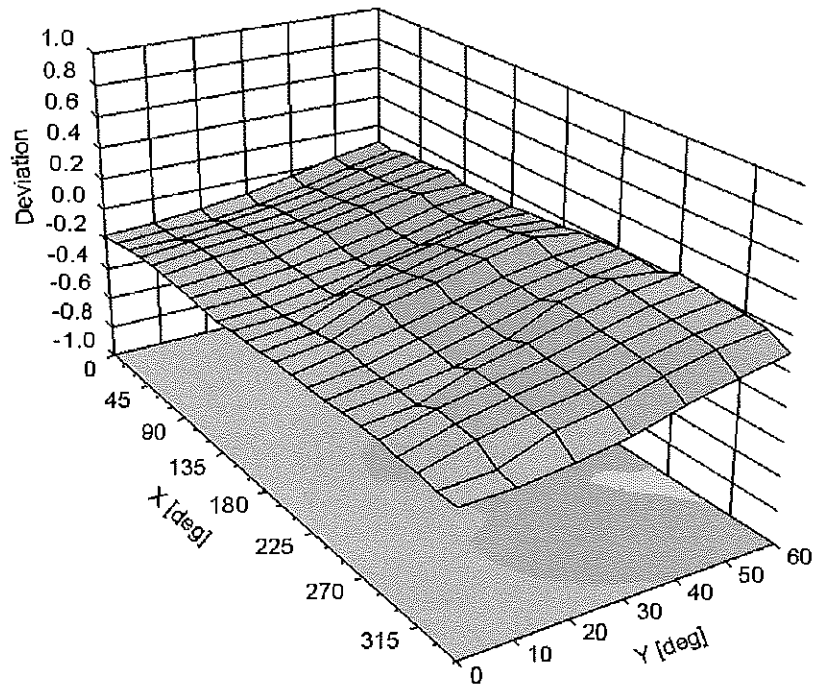

## DASY/EASY - Parameters of Probe: ES3DV3 - SN:3209

### Other Probe Parameters

|   |            |
|---|------------|
| Sensor Arrangement                            | Triangular |
| Connector Angle (°)                           | -40.6      |
| Mechanical Surface Detection Mode             | enabled    |
| Optical Surface Detection Mode                | disabled   |
| Probe Overall Length                          | 337 mm     |
| Probe Body Diameter                           | 10 mm      |
| Tip Length                                    | 10 mm      |
| Tip Diameter                                  | 4 mm       |
| Probe Tip to Sensor X Calibration Point       | 2 mm       |
| Probe Tip to Sensor Y Calibration Point       | 2 mm       |
| Probe Tip to Sensor Z Calibration Point       | 2 mm       |
| Recommended Measurement Distance from Surface | 3 mm       |



Accredited by the Swiss Accreditation Service (SAS)  
The Swiss Accreditation Service is one of the signatories to the EA  
Multilateral Agreement for the recognition of calibration certificates

Accreditation No.: **SCS 108**

Client **PC Test**

Certificate No: **ES3-3263\_May13**

## CALIBRATION CERTIFICATE

Object **ES3DV3 - SN:3263**

Calibration procedure(s) **QA CAL-01.v8, QA CAL-23.v4, QA CAL-25.v4  
Calibration procedure for dosimetric E-field probes**

Calibration date: **May 16, 2013**

*✓ KOK  
5/23/13*

This calibration certificate documents the traceability to national standards, which realize the physical units of measurements (SI).  
The measurements and the uncertainties with confidence probability are given on the following pages and are part of the certificate.

All calibrations have been conducted in the closed laboratory facility: environment temperature (22 ± 3)°C and humidity < 70%.

Calibration Equipment used (M&TE critical for calibration)

| Primary Standards          | ID              | Cal Date (Certificate No.)        | Scheduled Calibration  |
|----------------------------|-----------------|-----------------------------------|------------------------|
| Power meter E4419B         | GB41293874      | 04-Apr-13 (No. 217-01733)         | Apr-14                 |
| Power sensor E4412A        | MY41498087      | 04-Apr-13 (No. 217-01733)         | Apr-14                 |
| Reference 3 dB Attenuator  | SN: S5054 (3c)  | 04-Apr-13 (No. 217-01737)         | Apr-14                 |
| Reference 20 dB Attenuator | SN: S5277 (20x) | 04-Apr-13 (No. 217-01735)         | Apr-14                 |
| Reference 30 dB Attenuator | SN: S5129 (30b) | 04-Apr-13 (No. 217-01738)         | Apr-14                 |
| Reference Probe ES3DV2     | SN: 3013        | 28-Dec-12 (No. ES3-3013_Dec12)    | Dec-13                 |
| DAE4                       | SN: 660         | 31-Jan-13 (No. DAE4-660_Jan13)    | Jan-14                 |
| Secondary Standards        | ID              | Check Date (in house)             | Scheduled Check        |
| RF generator HP 8648C      | US3642U01700    | 4-Aug-99 (in house check Apr-13)  | In house check: Apr-15 |
| Network Analyzer HP 8753E  | US37390585      | 18-Oct-01 (in house check Oct-12) | In house check: Oct-13 |

|                | Name          | Function              | Signature            |
|----------------|---------------|-----------------------|----------------------|
| Calibrated by: | Leif Klysner  | Laboratory Technician | <i>Leif Klysner</i>  |
| Approved by:   | Katja Pokovic | Technical Manager     | <i>Katja Pokovic</i> |
|                |               |                       | Issued: May 17, 2013 |

This calibration certificate shall not be reproduced except in full without written approval of the laboratory.



Accredited by the Swiss Accreditation Service (SAS)

Accreditation No.: **SCS 108**

The Swiss Accreditation Service is one of the signatories to the EA  
 Multilateral Agreement for the recognition of calibration certificates

**Glossary:**

|                          |   |
|--------------------------|---|
| TSL                      | tissue simulating liquid  |
| NORM <sub>x,y,z</sub>    | sensitivity in free space   |
| ConvF                    | sensitivity in TSL / NORM <sub>x,y,z</sub>  |
| DCP                      | diode compression point   |
| CF                       | crest factor (1/duty_cycle) of the RF signal  |
| A, B, C, D               | modulation dependent linearization parameters   |
| Polarization $\varphi$   | $\varphi$ rotation around probe axis  |
| Polarization $\vartheta$ | $\vartheta$ rotation around an axis that is in the plane normal to probe axis (at measurement center),<br>i.e., $\vartheta = 0$ is normal to probe axis |

**Calibration is Performed According to the Following Standards:**

- a) IEEE Std 1528-2003, "IEEE Recommended Practice for Determining the Peak Spatial-Averaged Specific Absorption Rate (SAR) in the Human Head from Wireless Communications Devices: Measurement Techniques", December 2003
- b) IEC 62209-1, "Procedure to measure the Specific Absorption Rate (SAR) for hand-held devices used in close proximity to the ear (frequency range of 300 MHz to 3 GHz)", February 2005

**Methods Applied and Interpretation of Parameters:**

- *NORM<sub>x,y,z</sub>*: Assessed for E-field polarization  $\vartheta = 0$  ( $f \leq 900$  MHz in TEM-cell;  $f > 1800$  MHz: R22 waveguide). *NORM<sub>x,y,z</sub>* are only intermediate values, i.e., the uncertainties of *NORM<sub>x,y,z</sub>* does not affect the  $E^2$ -field uncertainty inside TSL (see below *ConvF*).
- *NORM(f)<sub>x,y,z</sub>* = *NORM<sub>x,y,z</sub>* \* *frequency\_response* (see Frequency Response Chart). This linearization is implemented in DASY4 software versions later than 4.2. The uncertainty of the frequency response is included in the stated uncertainty of *ConvF*.
- *DCP<sub>x,y,z</sub>*: DCP are numerical linearization parameters assessed based on the data of power sweep with CW signal (no uncertainty required). DCP does not depend on frequency nor media.
- *PAR*: PAR is the Peak to Average Ratio that is not calibrated but determined based on the signal characteristics
- *A<sub>x,y,z</sub>*; *B<sub>x,y,z</sub>*; *C<sub>x,y,z</sub>*; *D<sub>x,y,z</sub>*; *VR<sub>x,y,z</sub>*; *A, B, C, D* are numerical linearization parameters assessed based on the data of power sweep for specific modulation signal. The parameters do not depend on frequency nor media. *VR* is the maximum calibration range expressed in RMS voltage across the diode.
- *ConvF and Boundary Effect Parameters*: Assessed in flat phantom using E-field (or Temperature Transfer Standard for  $f \leq 800$  MHz) and inside waveguide using analytical field distributions based on power measurements for  $f > 800$  MHz. The same setups are used for assessment of the parameters applied for boundary compensation (alpha, depth) of which typical uncertainty values are given. These parameters are used in DASY4 software to improve probe accuracy close to the boundary. The sensitivity in TSL corresponds to *NORM<sub>x,y,z</sub>* \* *ConvF* whereby the uncertainty corresponds to that given for *ConvF*. A frequency dependent *ConvF* is used in DASY version 4.4 and higher which allows extending the validity from  $\pm 50$  MHz to  $\pm 100$  MHz.
- *Spherical isotropy (3D deviation from isotropy)*: in a field of low gradients realized using a flat phantom exposed by a patch antenna.
- *Sensor Offset*: The sensor offset corresponds to the offset of virtual measurement center from the probe tip (on probe axis). No tolerance required.

# Probe ES3DV3

## SN:3263

Manufactured: January 25, 2010  
Calibrated: May 16, 2013

Calibrated for DASY/EASY Systems  
(Note: non-compatible with DASY2 system!)

## DASY/EASY - Parameters of Probe: ES3DV3 - SN:3263

### Basic Calibration Parameters

|   | Sensor X | Sensor Y | Sensor Z | Unc (k=2)     |
|---|----------|----------|----------|---------------|
| Norm ( $\mu\text{V}/(\text{V}/\text{m})^2$ ) <sup>A</sup> | 1.21     | 1.25     | 1.12     | $\pm 10.1 \%$ |
| DCP (mV) <sup>B</sup>                                     | 101.2    | 100.2    | 103.7    |               |

### Modulation Calibration Parameters

| UID | Communication System Name |   | A<br>dB | B<br>dB $\sqrt{\mu\text{V}}$ | C   | D<br>dB | VR<br>mV | Unc <sup>E</sup><br>(k=2) |
|-----|---------------------------|---|---------|------------------------------|-----|---------|----------|---------------------------|
| 0   | CW                        | X | 0.0     | 0.0                          | 1.0 | 0.00    | 156.5    | $\pm 2.5 \%$              |
|     |                           | Y | 0.0     | 0.0                          | 1.0 |         | 153.2    |                           |
|     |                           | Z | 0.0     | 0.0                          | 1.0 |         | 147.2    |                           |

The reported uncertainty of measurement is stated as the standard uncertainty of measurement multiplied by the coverage factor  $k=2$ , which for a normal distribution corresponds to a coverage probability of approximately 95%.

<sup>A</sup> The uncertainties of NormX,Y,Z do not affect the  $E^2$ -field uncertainty inside TSL (see Pages 5 and 6).

<sup>B</sup> Numerical linearization parameter: uncertainty not required.

<sup>E</sup> Uncertainty is determined using the max. deviation from linear response applying rectangular distribution and is expressed for the square of the field value.

## DASY/EASY - Parameters of Probe: ES3DV3 - SN:3263

### Calibration Parameter Determined in Head Tissue Simulating Media

| f (MHz) <sup>C</sup> | Relative Permittivity <sup>F</sup> | Conductivity (S/m) <sup>F</sup> | ConvF X | ConvF Y | ConvF Z | Alpha | Depth (mm) | Unct. (k=2) |
|----------------------|------------------------------------|---------------------------------|---------|---------|---------|-------|------------|-------------|
| 750                  | 41.9                               | 0.89                            | 6.51    | 6.51    | 6.51    | 0.21  | 2.29       | ± 12.0 %    |
| 835                  | 41.5                               | 0.90                            | 6.29    | 6.29    | 6.29    | 0.50  | 1.38       | ± 12.0 %    |
| 1750                 | 40.1                               | 1.37                            | 5.30    | 5.30    | 5.30    | 0.45  | 1.54       | ± 12.0 %    |
| 1900                 | 40.0                               | 1.40                            | 5.11    | 5.11    | 5.11    | 0.57  | 1.38       | ± 12.0 %    |
| 2450                 | 39.2                               | 1.80                            | 4.47    | 4.47    | 4.47    | 0.59  | 1.49       | ± 12.0 %    |
| 2600                 | 39.0                               | 1.96                            | 4.31    | 4.31    | 4.31    | 0.80  | 1.28       | ± 12.0 %    |

<sup>C</sup> Frequency validity of ± 100 MHz only applies for DASY v4.4 and higher (see Page 2), else it is restricted to ± 50 MHz. The uncertainty is the RSS of the ConvF uncertainty at calibration frequency and the uncertainty for the indicated frequency band.

<sup>F</sup> At frequencies below 3 GHz, the validity of tissue parameters ( $\epsilon$  and  $\sigma$ ) can be relaxed to ± 10% if liquid compensation formula is applied to measured SAR values. At frequencies above 3 GHz, the validity of tissue parameters ( $\epsilon$  and  $\sigma$ ) is restricted to ± 5%. The uncertainty is the RSS of the ConvF uncertainty for indicated target tissue parameters.

## DASY/EASY - Parameters of Probe: ES3DV3 - SN:3263

### Calibration Parameter Determined in Body Tissue Simulating Media

| f (MHz) <sup>C</sup> | Relative Permittivity <sup>F</sup> | Conductivity (S/m) <sup>F</sup> | ConvF X | ConvF Y | ConvF Z | Alpha | Depth (mm) | Unct. (k=2) |
|----------------------|------------------------------------|---------------------------------|---------|---------|---------|-------|------------|-------------|
| 750                  | 55.5                               | 0.96                            | 6.37    | 6.37    | 6.37    | 0.34  | 1.82       | ± 12.0 %    |
| 835                  | 55.2                               | 0.97                            | 6.29    | 6.29    | 6.29    | 0.54  | 1.39       | ± 12.0 %    |
| 1750                 | 53.4                               | 1.49                            | 5.01    | 5.01    | 5.01    | 0.72  | 1.27       | ± 12.0 %    |
| 1900                 | 53.3                               | 1.52                            | 4.78    | 4.78    | 4.78    | 0.53  | 1.56       | ± 12.0 %    |
| 2450                 | 52.7                               | 1.95                            | 4.33    | 4.33    | 4.33    | 0.80  | 1.14       | ± 12.0 %    |
| 2600                 | 52.5                               | 2.16                            | 4.14    | 4.14    | 4.14    | 0.80  | 1.02       | ± 12.0 %    |

<sup>C</sup> Frequency validity of ± 100 MHz only applies for DASY v4.4 and higher (see Page 2), else it is restricted to ± 50 MHz. The uncertainty is the RSS of the ConvF uncertainty at calibration frequency and the uncertainty for the indicated frequency band.

<sup>F</sup> At frequencies below 3 GHz, the validity of tissue parameters ( $\epsilon$  and  $\sigma$ ) can be relaxed to ± 10% if liquid compensation formula is applied to measured SAR values. At frequencies above 3 GHz, the validity of tissue parameters ( $\epsilon$  and  $\sigma$ ) is restricted to ± 5%. The uncertainty is the RSS of the ConvF uncertainty for indicated target tissue parameters.

### Frequency Response of E-Field (TEM-Cell:ifi110 EXX, Waveguide: R22)

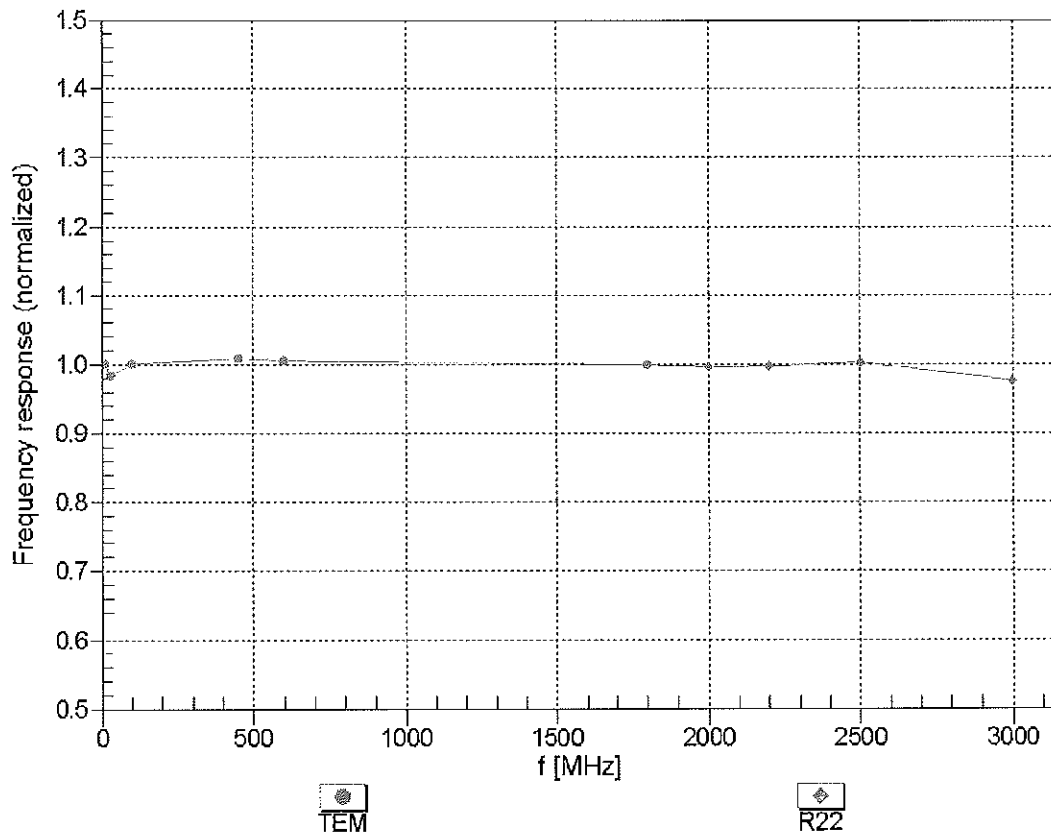

Uncertainty of Frequency Response of E-field:  $\pm 6.3\%$  (k=2)

### Receiving Pattern ( $\phi$ ), $\theta = 0^\circ$

f=600 MHz,TEM

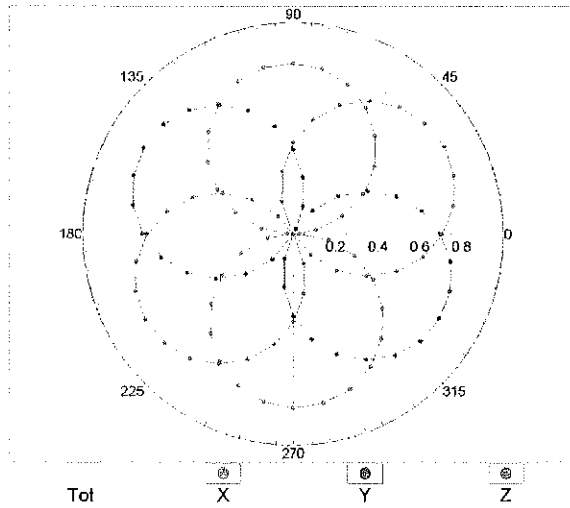

f=1800 MHz,R22

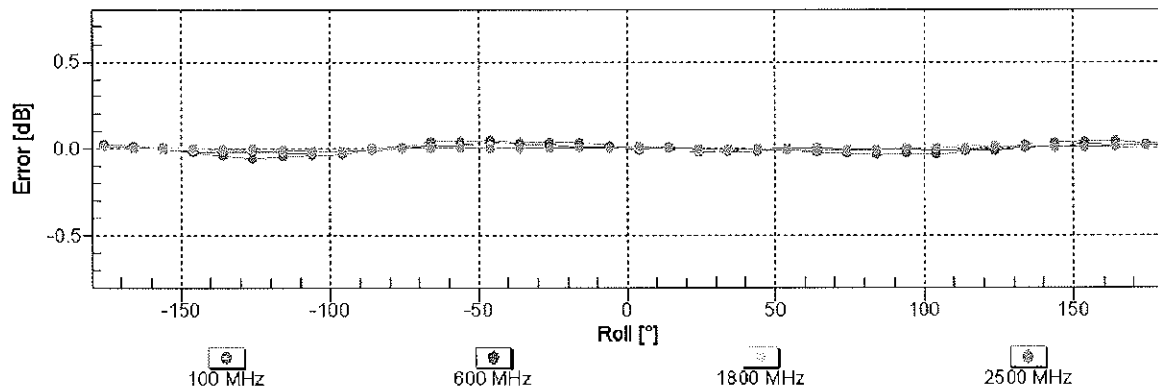
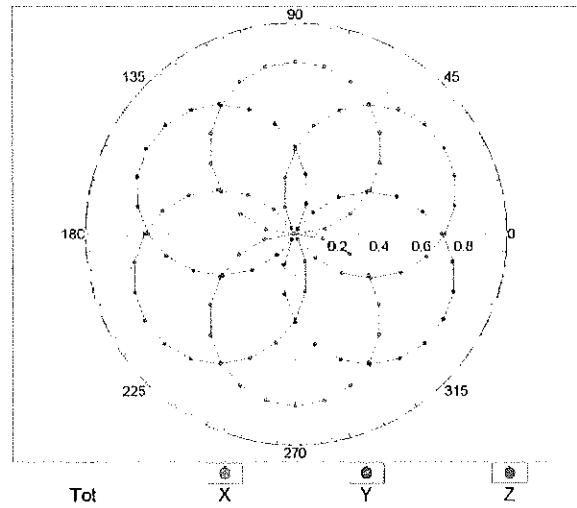

Uncertainty of Axial Isotropy Assessment:  $\pm 0.5\%$  (k=2)

### Dynamic Range f(SAR<sub>head</sub>) (TEM cell , f = 900 MHz)

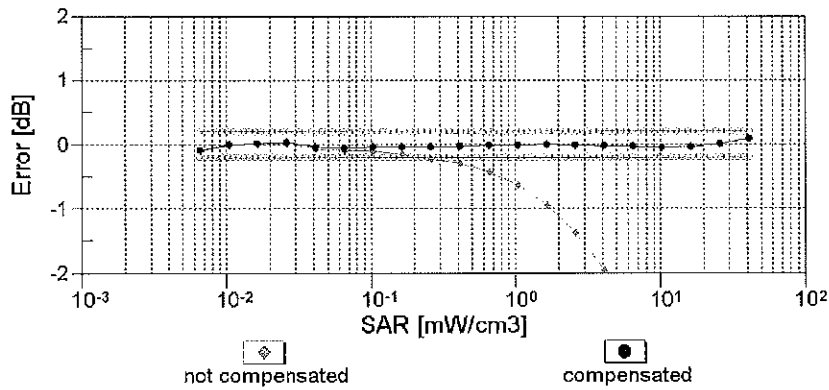
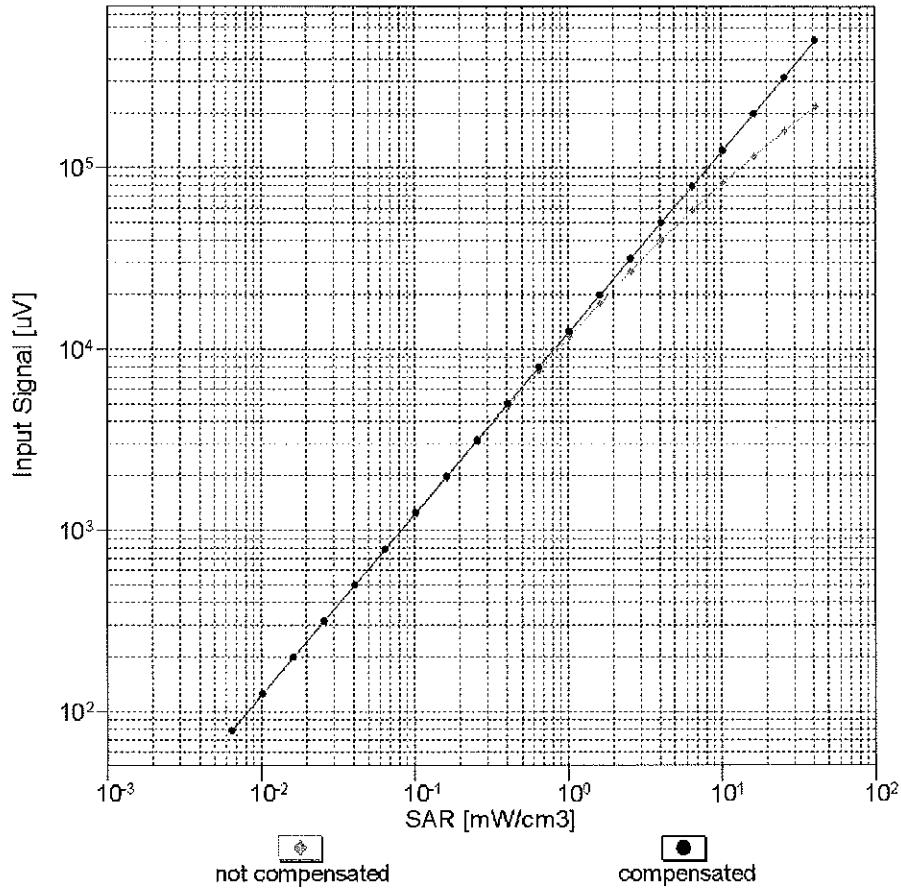

Uncertainty of Linearity Assessment: ± 0.6% (k=2)

## Conversion Factor Assessment

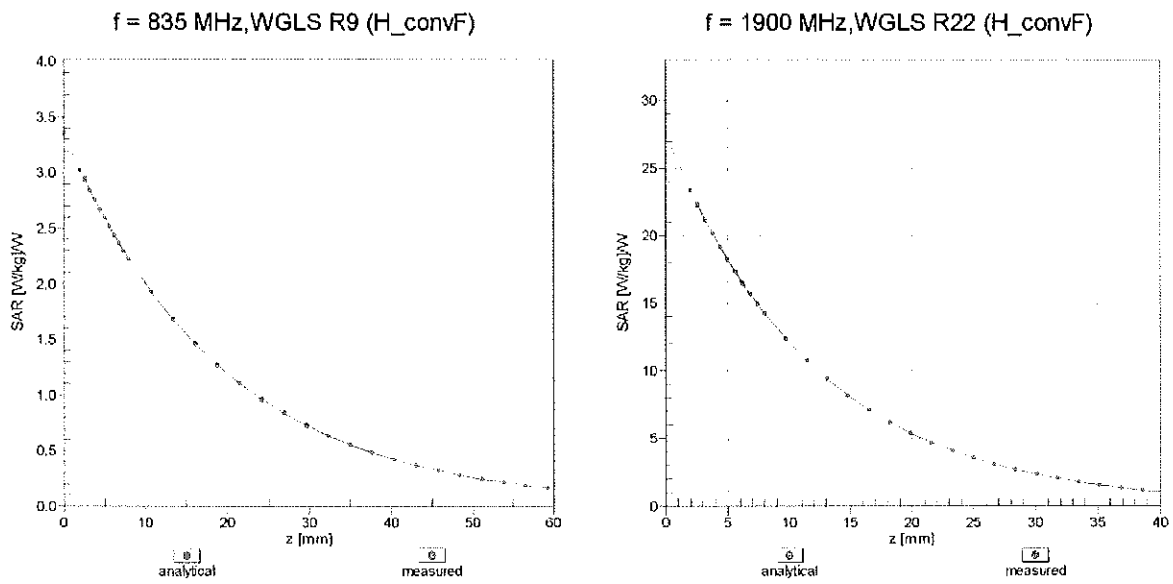

## Deviation from Isotropy in Liquid Error ( $\phi, \theta$ ), f = 900 MHz

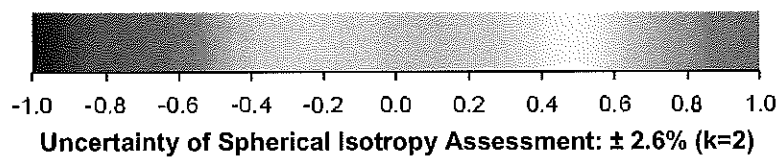
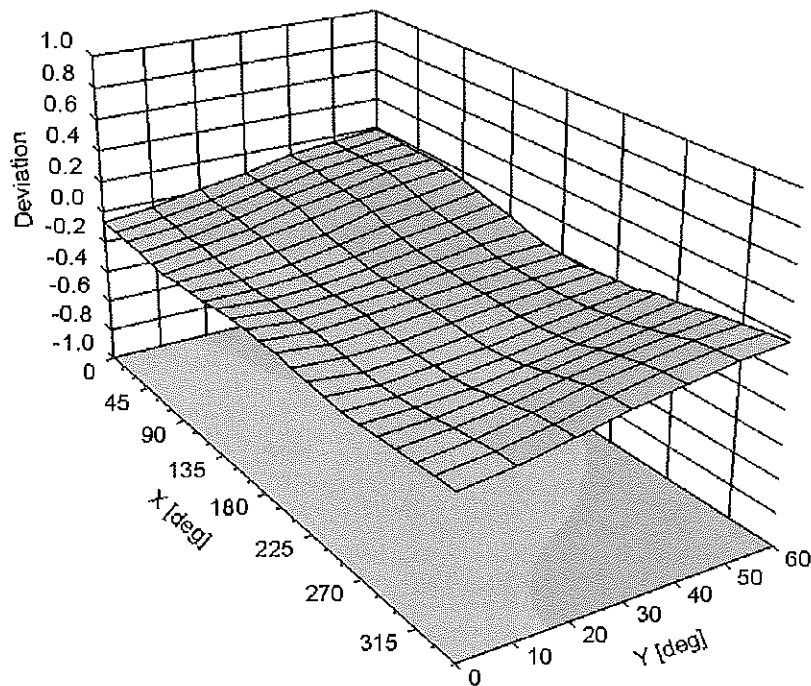

## DASY/EASY - Parameters of Probe: ES3DV3 - SN:3263

### Other Probe Parameters

|   |            |
|---|------------|
| Sensor Arrangement                            | Triangular |
| Connector Angle (°)                           | -116       |
| Mechanical Surface Detection Mode             | enabled    |
| Optical Surface Detection Mode                | disabled   |
| Probe Overall Length                          | 337 mm     |
| Probe Body Diameter                           | 10 mm      |
| Tip Length                                    | 10 mm      |
| Tip Diameter                                  | 4 mm       |
| Probe Tip to Sensor X Calibration Point       | 2 mm       |
| Probe Tip to Sensor Y Calibration Point       | 2 mm       |
| Probe Tip to Sensor Z Calibration Point       | 2 mm       |
| Recommended Measurement Distance from Surface | 3 mm       |



Accredited by the Swiss Accreditation Service (SAS)  
The Swiss Accreditation Service is one of the signatories to the EA  
Multilateral Agreement for the recognition of calibration certificates

Accreditation No.: **SCS 108**

Client **PC Test**

Certificate No: **D5GHzV2-1120\_Feb13**

## CALIBRATION CERTIFICATE

Object **D5GHzV2 - SN: 1120**

Calibration procedure(s) **QA CAL-22.v2  
Calibration procedure for dipole validation kits between 3-6 GHz**

Calibration date: **February 14, 2013**

*✓  
Kok  
2/2/13*

This calibration certificate documents the traceability to national standards, which realize the physical units of measurements (SI).  
The measurements and the uncertainties with confidence probability are given on the following pages and are part of the certificate.

All calibrations have been conducted in the closed laboratory facility: environment temperature ( $22 \pm 3$ )°C and humidity < 70%.

Calibration Equipment used (M&TE critical for calibration)

| Primary Standards           | ID #               | Cal Date (Certificate No.)        | Scheduled Calibration  |
|-----------------------------|--------------------|-----------------------------------|------------------------|
| Power meter EPM-442A        | GB37480704         | 01-Nov-12 (No. 217-01640)         | Oct-13                 |
| Power sensor HP 8481A       | US37292783         | 01-Nov-12 (No. 217-01640)         | Oct-13                 |
| Reference 20 dB Attenuator  | SN: 5058 (20k)     | 27-Mar-12 (No. 217-01530)         | Apr-13                 |
| Type-N mismatch combination | SN: 5047.3 / 06327 | 27-Mar-12 (No. 217-01533)         | Apr-13                 |
| Reference Probe EX3DV4      | SN: 3503           | 28-Dec-12 (No. EX3-3503_Dec12)    | Dec-13                 |
| DAE4                        | SN: 601            | 27-Jun-12 (No. DAE4-601_Jun12)    | Jun-13                 |
| Secondary Standards         | ID #               | Check Date (in house)             | Scheduled Check        |
| Power sensor HP 8481A       | MY41092317         | 18-Oct-02 (in house check Oct-11) | In house check: Oct-13 |
| RF generator R&S SMT-06     | 100005             | 04-Aug-99 (in house check Oct-11) | In house check: Oct-13 |
| Network Analyzer HP 8753E   | US37390585 S4206   | 18-Oct-01 (in house check Oct-12) | In house check: Oct-13 |

Calibrated by: **Israe El-Naouq**      Function: **Laboratory Technician**

Approved by: **Katja Pokovic**      Technical Manager

Signature  
*Israe El-Naouq*  
*Katja Pokovic*

Issued: February 14, 2013

This calibration certificate shall not be reproduced except in full without written approval of the laboratory.



Accredited by the Swiss Accreditation Service (SAS)  
The Swiss Accreditation Service is one of the signatories to the EA  
Multilateral Agreement for the recognition of calibration certificates

Accreditation No.: **SCS 108**

### Glossary:

|       |                                 |
|-------|---------------------------------|
| TSL   | tissue simulating liquid        |
| ConvF | sensitivity in TSL / NORM x,y,z |
| N/A   | not applicable or not measured  |

### Calibration is Performed According to the Following Standards:

- IEC 62209-2, "Evaluation of Human Exposure to Radio Frequency Fields from Handheld and Body-Mounted Wireless Communication Devices in the Frequency Range of 30 MHz to 6 GHz: Human models, Instrumentation, and Procedures"; Part 2: "Procedure to determine the Specific Absorption Rate (SAR) for including accessories and multiple transmitters", March 2010
- Federal Communications Commission Office of Engineering & Technology (FCC OET), "Evaluating Compliance with FCC Guidelines for Human Exposure to Radiofrequency Electromagnetic Fields; Additional Information for Evaluating Compliance of Mobile and Portable Devices with FCC Limits for Human Exposure to Radiofrequency Emissions", Supplement C (Edition 01-01) to Bulletin 65

### Additional Documentation:

- DASY4/5 System Handbook

### Methods Applied and Interpretation of Parameters:

- Measurement Conditions:** Further details are available from the Validation Report at the end of the certificate. All figures stated in the certificate are valid at the frequency indicated.
- Antenna Parameters with TSL:** The dipole is mounted with the spacer to position its feed point exactly below the center marking of the flat phantom section, with the arms oriented parallel to the body axis.
- Feed Point Impedance and Return Loss:** These parameters are measured with the dipole positioned under the liquid filled phantom. The impedance stated is transformed from the measurement at the SMA connector to the feed point. The Return Loss ensures low reflected power. No uncertainty required.
- Electrical Delay:** One-way delay between the SMA connector and the antenna feed point. No uncertainty required.
- SAR measured:** SAR measured at the stated antenna input power.
- SAR normalized:** SAR as measured, normalized to an input power of 1 W at the antenna connector.
- SAR for nominal TSL parameters:** The measured TSL parameters are used to calculate the nominal SAR result.

The reported uncertainty of measurement is stated as the standard uncertainty of measurement multiplied by the coverage factor  $k=2$ , which for a normal distribution corresponds to a coverage probability of approximately 95%.

## Measurement Conditions

DASY system configuration, as far as not given on page 1.

|                                     |  |                                  |
|-------------------------------------|--|----------------------------------|
| <b>DASY Version</b>                 | DASY5  | V52.8.5                          |
| <b>Extrapolation</b>                | Advanced Extrapolation   |                                  |
| <b>Phantom</b>                      | Modular Flat Phantom V5.0  |                                  |
| <b>Distance Dipole Center - TSL</b> | 10 mm  | with Spacer                      |
| <b>Zoom Scan Resolution</b>         | dx, dy = 4.0 mm, dz = 1.4 mm   | Graded Ratio = 1.4 (Z direction) |
| <b>Frequency</b>                    | 5200 MHz ± 1 MHz<br>5300 MHz ± 1 MHz<br>5500 MHz ± 1 MHz<br>5600 MHz ± 1 MHz<br>5800 MHz ± 1 MHz |                                  |

## Head TSL parameters at 5200 MHz

The following parameters and calculations were applied.

|  | Temperature     | Permittivity | Conductivity     |
|--|-----------------|--------------|------------------|
| <b>Nominal Head TSL parameters</b>             | 22.0 °C         | 36.0         | 4.66 mho/m       |
| <b>Measured Head TSL parameters</b>            | (22.0 ± 0.2) °C | 34.7 ± 6 %   | 4.47 mho/m ± 6 % |
| <b>Head TSL temperature change during test</b> | < 0.5 °C        | ----         | ----             |

## SAR result with Head TSL at 5200 MHz

| <b>SAR averaged over 1 cm<sup>3</sup> (1 g) of Head TSL</b> | Condition          |                                 |
|---|--------------------|---------------------------------|
| SAR measured  | 100 mW input power | 7.67 W/kg                       |
| SAR for nominal Head TSL parameters                         | normalized to 1W   | <b>76.0 W/kg ± 19.9 % (k=2)</b> |

| <b>SAR averaged over 10 cm<sup>3</sup> (10 g) of Head TSL</b> | condition          |                                 |
|---|--------------------|---------------------------------|
| SAR measured  | 100 mW input power | 2.18 W/kg                       |
| SAR for nominal Head TSL parameters                           | normalized to 1W   | <b>21.5 W/kg ± 19.5 % (k=2)</b> |

### Head TSL parameters at 5300 MHz

The following parameters and calculations were applied.

|   | Temperature     | Permittivity | Conductivity     |
|---|-----------------|--------------|------------------|
| Nominal Head TSL parameters             | 22.0 °C         | 35.9         | 4.76 mho/m       |
| Measured Head TSL parameters            | (22.0 ± 0.2) °C | 34.5 ± 6 %   | 4.57 mho/m ± 6 % |
| Head TSL temperature change during test | < 0.5 °C        | ----         | ----             |

### SAR result with Head TSL at 5300 MHz

| SAR averaged over 1 cm <sup>3</sup> (1 g) of Head TSL | Condition          |                                   |
|---|--------------------|-----------------------------------|
| SAR measured  | 100 mW input power | 7.94 W/kg                         |
| SAR for nominal Head TSL parameters                   | normalized to 1W   | <b>78.7 W / kg ± 19.9 % (k=2)</b> |

| SAR averaged over 10 cm <sup>3</sup> (10 g) of Head TSL | condition          |                                 |
|---|--------------------|---------------------------------|
| SAR measured  | 100 mW input power | 2.27 W/kg                       |
| SAR for nominal Head TSL parameters                     | normalized to 1W   | <b>22.4 W/kg ± 19.5 % (k=2)</b> |

### Head TSL parameters at 5500 MHz

The following parameters and calculations were applied.

|   | Temperature     | Permittivity | Conductivity     |
|---|-----------------|--------------|------------------|
| Nominal Head TSL parameters             | 22.0 °C         | 35.6         | 4.96 mho/m       |
| Measured Head TSL parameters            | (22.0 ± 0.2) °C | 34.2 ± 6 %   | 4.74 mho/m ± 6 % |
| Head TSL temperature change during test | < 0.5 °C        | ----         | ----             |

### SAR result with Head TSL at 5500 MHz

| SAR averaged over 1 cm <sup>3</sup> (1 g) of Head TSL | Condition          |                                 |
|---|--------------------|---------------------------------|
| SAR measured  | 100 mW input power | 8.09 W/kg                       |
| SAR for nominal Head TSL parameters                   | normalized to 1W   | <b>80.1 W/kg ± 19.9 % (k=2)</b> |

| SAR averaged over 10 cm <sup>3</sup> (10 g) of Head TSL | condition          |                                 |
|---|--------------------|---------------------------------|
| SAR measured  | 100 mW input power | 2.29 W/kg                       |
| SAR for nominal Head TSL parameters                     | normalized to 1W   | <b>22.6 W/kg ± 19.5 % (k=2)</b> |

### Head TSL parameters at 5600 MHz

The following parameters and calculations were applied.

|   | Temperature     | Permittivity | Conductivity     |
|---|-----------------|--------------|------------------|
| Nominal Head TSL parameters             | 22.0 °C         | 35.5         | 5.07 mho/m       |
| Measured Head TSL parameters            | (22.0 ± 0.2) °C | 34.1 ± 6 %   | 4.83 mho/m ± 6 % |
| Head TSL temperature change during test | < 0.5 °C        | ----         | ----             |

### SAR result with Head TSL at 5600 MHz

| SAR averaged over 1 cm <sup>3</sup> (1 g) of Head TSL | Condition          |                                 |
|---|--------------------|---------------------------------|
| SAR measured  | 100 mW input power | 8.08 W/kg                       |
| SAR for nominal Head TSL parameters                   | normalized to 1W   | <b>79.9 W/kg ± 19.9 % (k=2)</b> |

| SAR averaged over 10 cm <sup>3</sup> (10 g) of Head TSL | condition          |                                 |
|---|--------------------|---------------------------------|
| SAR measured  | 100 mW input power | 2.28 W/kg                       |
| SAR for nominal Head TSL parameters                     | normalized to 1W   | <b>22.5 W/kg ± 19.5 % (k=2)</b> |

### Head TSL parameters at 5800 MHz

The following parameters and calculations were applied.

|   | Temperature     | Permittivity | Conductivity     |
|---|-----------------|--------------|------------------|
| Nominal Head TSL parameters             | 22.0 °C         | 35.3         | 5.27 mho/m       |
| Measured Head TSL parameters            | (22.0 ± 0.2) °C | 33.9 ± 6 %   | 5.05 mho/m ± 6 % |
| Head TSL temperature change during test | < 0.5 °C        | ----         | ----             |

### SAR result with Head TSL at 5800 MHz

| SAR averaged over 1 cm <sup>3</sup> (1 g) of Head TSL | Condition          |                                 |
|---|--------------------|---------------------------------|
| SAR measured  | 100 mW input power | 7.57 W/kg                       |
| SAR for nominal Head TSL parameters                   | normalized to 1W   | <b>74.9 W/kg ± 19.9 % (k=2)</b> |

| SAR averaged over 10 cm <sup>3</sup> (10 g) of Head TSL | condition          |                                 |
|---|--------------------|---------------------------------|
| SAR measured  | 100 mW input power | 2.13 W/kg                       |
| SAR for nominal Head TSL parameters                     | normalized to 1W   | <b>21.0 W/kg ± 19.5 % (k=2)</b> |

### Body TSL parameters at 5200 MHz

The following parameters and calculations were applied.

|   | Temperature     | Permittivity | Conductivity     |
|---|-----------------|--------------|------------------|
| Nominal Body TSL parameters             | 22.0 °C         | 49.0         | 5.30 mho/m       |
| Measured Body TSL parameters            | (22.0 ± 0.2) °C | 46.9 ± 6 %   | 5.36 mho/m ± 6 % |
| Body TSL temperature change during test | < 0.5 °C        | ----         | ----             |

### SAR result with Body TSL at 5200 MHz

| SAR averaged over 1 cm <sup>3</sup> (1 g) of Body TSL | Condition          |                                 |
|---|--------------------|---------------------------------|
| SAR measured  | 100 mW input power | 7.73 W/kg                       |
| SAR for nominal Body TSL parameters                   | normalized to 1W   | <b>76.6 W/kg ± 19.9 % (k=2)</b> |

| SAR averaged over 10 cm <sup>3</sup> (10 g) of Body TSL | condition          |                                 |
|---|--------------------|---------------------------------|
| SAR measured  | 100 mW input power | 2.17 W/kg                       |
| SAR for nominal Body TSL parameters                     | normalized to 1W   | <b>21.5 W/kg ± 19.5 % (k=2)</b> |

### Body TSL parameters at 5300 MHz

The following parameters and calculations were applied.

|   | Temperature     | Permittivity | Conductivity     |
|---|-----------------|--------------|------------------|
| Nominal Body TSL parameters             | 22.0 °C         | 48.9         | 5.42 mho/m       |
| Measured Body TSL parameters            | (22.0 ± 0.2) °C | 46.7 ± 6 %   | 5.48 mho/m ± 6 % |
| Body TSL temperature change during test | < 0.5 °C        | ----         | ----             |

### SAR result with Body TSL at 5300 MHz

| SAR averaged over 1 cm <sup>3</sup> (1 g) of Body TSL | Condition          |                                 |
|---|--------------------|---------------------------------|
| SAR measured  | 100 mW input power | 7.75 W/kg                       |
| SAR for nominal Body TSL parameters                   | normalized to 1W   | <b>76.8 W/kg ± 19.9 % (k=2)</b> |

| SAR averaged over 10 cm <sup>3</sup> (10 g) of Body TSL | condition          |                                 |
|---|--------------------|---------------------------------|
| SAR measured  | 100 mW input power | 2.18 W/kg                       |
| SAR for nominal Body TSL parameters                     | normalized to 1W   | <b>21.5 W/kg ± 19.5 % (k=2)</b> |

### Body TSL parameters at 5500 MHz

The following parameters and calculations were applied.

|   | Temperature     | Permittivity | Conductivity     |
|---|-----------------|--------------|------------------|
| Nominal Body TSL parameters             | 22.0 °C         | 48.6         | 5.65 mho/m       |
| Measured Body TSL parameters            | (22.0 ± 0.2) °C | 46.3 ± 6 %   | 5.71 mho/m ± 6 % |
| Body TSL temperature change during test | < 0.5 °C        | ----         | ----             |

### SAR result with Body TSL at 5500 MHz

| SAR averaged over 1 cm <sup>3</sup> (1 g) of Body TSL | Condition          |                                 |
|---|--------------------|---------------------------------|
| SAR measured  | 100 mW input power | 8.06 W/kg                       |
| SAR for nominal Body TSL parameters                   | normalized to 1W   | <b>79.8 W/kg ± 19.9 % (k=2)</b> |

| SAR averaged over 10 cm <sup>3</sup> (10 g) of Body TSL | condition          |                                 |
|---|--------------------|---------------------------------|
| SAR measured  | 100 mW input power | 2.24 W/kg                       |
| SAR for nominal Body TSL parameters                     | normalized to 1W   | <b>22.1 W/kg ± 19.5 % (k=2)</b> |

### Body TSL parameters at 5600 MHz

The following parameters and calculations were applied.

|   | Temperature     | Permittivity | Conductivity     |
|---|-----------------|--------------|------------------|
| Nominal Body TSL parameters             | 22.0 °C         | 48.5         | 5.77 mho/m       |
| Measured Body TSL parameters            | (22.0 ± 0.2) °C | 46.2 ± 6 %   | 5.83 mho/m ± 6 % |
| Body TSL temperature change during test | < 0.5 °C        | ----         | ----             |

### SAR result with Body TSL at 5600 MHz

| SAR averaged over 1 cm <sup>3</sup> (1 g) of Body TSL | Condition          |                                 |
|---|--------------------|---------------------------------|
| SAR measured  | 100 mW input power | 8.15 W/kg                       |
| SAR for nominal Body TSL parameters                   | normalized to 1W   | <b>80.7 W/kg ± 19.9 % (k=2)</b> |

| SAR averaged over 10 cm <sup>3</sup> (10 g) of Body TSL | condition          |                                 |
|---|--------------------|---------------------------------|
| SAR measured  | 100 mW input power | 2.26 W/kg                       |
| SAR for nominal Body TSL parameters                     | normalized to 1W   | <b>22.3 W/kg ± 19.5 % (k=2)</b> |

### Body TSL parameters at 5800 MHz

The following parameters and calculations were applied.

|   | Temperature     | Permittivity | Conductivity     |
|---|-----------------|--------------|------------------|
| Nominal Body TSL parameters             | 22.0 °C         | 48.2         | 6.00 mho/m       |
| Measured Body TSL parameters            | (22.0 ± 0.2) °C | 45.9 ± 6 %   | 6.12 mho/m ± 6 % |
| Body TSL temperature change during test | < 0.5 °C        | ----         | ----             |

### SAR result with Body TSL at 5800 MHz

| SAR averaged over 1 cm <sup>3</sup> (1 g) of Body TSL | Condition          |                                 |
|---|--------------------|---------------------------------|
| SAR measured  | 100 mW input power | 7.62 W/kg                       |
| SAR for nominal Body TSL parameters                   | normalized to 1W   | <b>75.5 W/kg ± 19.9 % (k=2)</b> |

| SAR averaged over 10 cm <sup>3</sup> (10 g) of Body TSL | condition          |                                 |
|---|--------------------|---------------------------------|
| SAR measured  | 100 mW input power | 2.12 W/kg                       |
| SAR for nominal Body TSL parameters                     | normalized to 1W   | <b>20.9 W/kg ± 19.5 % (k=2)</b> |

## Appendix

### Antenna Parameters with Head TSL at 5200 MHz

|                                      |                                |
|--------------------------------------|--------------------------------|
| Impedance, transformed to feed point | 53.8 $\Omega$ - 6.3 j $\Omega$ |
| Return Loss                          | - 23.0 dB                      |

### Antenna Parameters with Head TSL at 5300 MHz

|                                      |                                |
|--------------------------------------|--------------------------------|
| Impedance, transformed to feed point | 50.1 $\Omega$ + 0.5 j $\Omega$ |
| Return Loss                          | - 45.3 dB                      |

### Antenna Parameters with Head TSL at 5500 MHz

|                                      |                                |
|--------------------------------------|--------------------------------|
| Impedance, transformed to feed point | 51.0 $\Omega$ - 0.9 j $\Omega$ |
| Return Loss                          | - 37.9 dB                      |

### Antenna Parameters with Head TSL at 5600 MHz

|                                      |                                |
|--------------------------------------|--------------------------------|
| Impedance, transformed to feed point | 55.3 $\Omega$ - 0.9 j $\Omega$ |
| Return Loss                          | - 25.8 dB                      |

### Antenna Parameters with Head TSL at 5800 MHz

|                                      |                                |
|--------------------------------------|--------------------------------|
| Impedance, transformed to feed point | 53.5 $\Omega$ + 3.3 j $\Omega$ |
| Return Loss                          | - 26.7 dB                      |

### Antenna Parameters with Body TSL at 5200 MHz

|                                      |                                |
|--------------------------------------|--------------------------------|
| Impedance, transformed to feed point | 53.7 $\Omega$ - 4.8 j $\Omega$ |
| Return Loss                          | - 24.8 dB                      |

### Antenna Parameters with Body TSL at 5300 MHz

|                                      |                                |
|--------------------------------------|--------------------------------|
| Impedance, transformed to feed point | 50.2 $\Omega$ + 2.4 j $\Omega$ |
| Return Loss                          | - 32.5 dB                      |

### Antenna Parameters with Body TSL at 5500 MHz

|                                      |                                |
|--------------------------------------|--------------------------------|
| Impedance, transformed to feed point | 51.6 $\Omega$ - 1.5 j $\Omega$ |
| Return Loss                          | - 33.3 dB                      |

### Antenna Parameters with Body TSL at 5600 MHz

|                                      |                                |
|--------------------------------------|--------------------------------|
| Impedance, transformed to feed point | 57.4 $\Omega$ + 0.9 j $\Omega$ |
| Return Loss                          | - 23.2 dB                      |

## Antenna Parameters with Body TSL at 5800 MHz

|                                      |                                |
|--------------------------------------|--------------------------------|
| Impedance, transformed to feed point | 53.5 $\Omega$ + 3.2 j $\Omega$ |
| Return Loss                          | - 26.7 dB                      |

## General Antenna Parameters and Design

|                                  |          |
|----------------------------------|----------|
| Electrical Delay (one direction) | 1.206 ns |
|----------------------------------|----------|

After long term use with 100W radiated power, only a slight warming of the dipole near the feedpoint can be measured.

The dipole is made of standard semirigid coaxial cable. The center conductor of the feeding line is directly connected to the second arm of the dipole. The antenna is therefore short-circuited for DC-signals. On some of the dipoles, small end caps are added to the dipole arms in order to improve matching when loaded according to the position as explained in the "Measurement Conditions" paragraph. The SAR data are not affected by this change. The overall dipole length is still according to the Standard.

No excessive force must be applied to the dipole arms, because they might bend or the soldered connections near the feedpoint may be damaged.

## Additional EUT Data

|                 |                    |
|-----------------|--------------------|
| Manufactured by | SPEAG              |
| Manufactured on | September 08, 2011 |

## DASY5 Validation Report for Head TSL

Date: 08.02.2013

Test Laboratory: SPEAG, Zurich, Switzerland

**DUT: Dipole 5GHz; Type: D5GHzV2; Serial: D5GHzV2 - SN: 1120**

Communication System: CW; Frequency: 5200 MHz, Frequency: 5300 MHz, Frequency: 5500 MHz, Frequency: 5600 MHz, Frequency: 5800 MHz

Medium parameters used:  $f = 5200$  MHz;  $\sigma = 4.47$  S/m;  $\epsilon_r = 34.7$ ;  $\rho = 1000$  kg/m<sup>3</sup>, Medium parameters used:  $f = 5300$  MHz;  $\sigma = 4.57$  S/m;  $\epsilon_r = 34.5$ ;  $\rho = 1000$  kg/m<sup>3</sup>, Medium parameters used:  $f = 5500$  MHz;  $\sigma = 4.74$  S/m;  $\epsilon_r = 34.2$ ;  $\rho = 1000$  kg/m<sup>3</sup>, Medium parameters used:  $f = 5600$  MHz;  $\sigma = 4.83$  S/m;  $\epsilon_r = 34.1$ ;  $\rho = 1000$  kg/m<sup>3</sup>, Medium parameters used:  $f = 5800$  MHz;  $\sigma = 5.05$  S/m;  $\epsilon_r = 33.9$ ;  $\rho = 1000$  kg/m<sup>3</sup>

Phantom section: Flat Section

Measurement Standard: DASY5 (IEEE/IEC/ANSI C63.19-2007)

DASY52 Configuration:

- Probe: EX3DV4 - SN3503; ConvF(5.41, 5.41, 5.41); Calibrated: 28.12.2012, ConvF(5.1, 5.1, 5.1); Calibrated: 28.12.2012, ConvF(4.91, 4.91, 4.91); Calibrated: 28.12.2012, ConvF(4.76, 4.76, 4.76); Calibrated: 28.12.2012, ConvF(4.81, 4.81, 4.81); Calibrated: 28.12.2012;
- Sensor-Surface: 1.4mm (Mechanical Surface Detection)
- Electronics: DAE4 Sn601; Calibrated: 27.06.2012
- Phantom: Flat Phantom 5.0 (front); Type: QD000P50AA; Serial: 1001
- DASY52 52.8.5(1059); SEMCAD X 14.6.8(7028)

**Dipole Calibration for Head Tissue/Pin=100mW, dist=10mm, f=5200 MHz/Zoom Scan, dist=1.4mm (8x8x7)/Cube 0:** Measurement grid: dx=4mm, dy=4mm, dz=1.4mm

Reference Value = 61.561 V/m; Power Drift = 0.05 dB

Peak SAR (extrapolated) = 28.8 W/kg

**SAR(1 g) = 7.67 W/kg; SAR(10 g) = 2.18 W/kg**

Maximum value of SAR (measured) = 17.7 W/kg

**Dipole Calibration for Head Tissue/Pin=100mW, dist=10mm, f=5300 MHz/Zoom Scan, dist=1.4mm (8x8x7)/Cube 0:** Measurement grid: dx=4mm, dy=4mm, dz=1.4mm

Reference Value = 62.429 V/m; Power Drift = 0.03 dB

Peak SAR (extrapolated) = 30.3 W/kg

**SAR(1 g) = 7.94 W/kg; SAR(10 g) = 2.27 W/kg**

Maximum value of SAR (measured) = 18.5 W/kg

**Dipole Calibration for Head Tissue/Pin=100mW, dist=10mm, f=5500 MHz/Zoom Scan, dist=1.4mm (8x8x7)/Cube 0:** Measurement grid: dx=4mm, dy=4mm, dz=1.4mm

Reference Value = 61.998 V/m; Power Drift = 0.08 dB

Peak SAR (extrapolated) = 32.7 W/kg

**SAR(1 g) = 8.09 W/kg; SAR(10 g) = 2.29 W/kg**

Maximum value of SAR (measured) = 19.3 W/kg

**Dipole Calibration for Head Tissue/Pin=100mW, dist=10mm, f=5600 MHz/Zoom Scan, dist=1.4mm (8x8x7)/Cube 0:** Measurement grid: dx=4mm, dy=4mm, dz=1.4mm  
Reference Value = 62.540 V/m; Power Drift = 0.02 dB  
Peak SAR (extrapolated) = 33.3 W/kg  
**SAR(1 g) = 8.08 W/kg; SAR(10 g) = 2.28 W/kg**  
Maximum value of SAR (measured) = 19.5 W/kg

**Dipole Calibration for Head Tissue/Pin=100mW, dist=10mm, f=5800 MHz/Zoom Scan, dist=1.4mm (8x8x7)/Cube 0:** Measurement grid: dx=4mm, dy=4mm, dz=1.4mm  
Reference Value = 58.600 V/m; Power Drift = 0.09 dB  
Peak SAR (extrapolated) = 32.9 W/kg  
**SAR(1 g) = 7.57 W/kg; SAR(10 g) = 2.13 W/kg**  
Maximum value of SAR (measured) = 18.8 W/kg

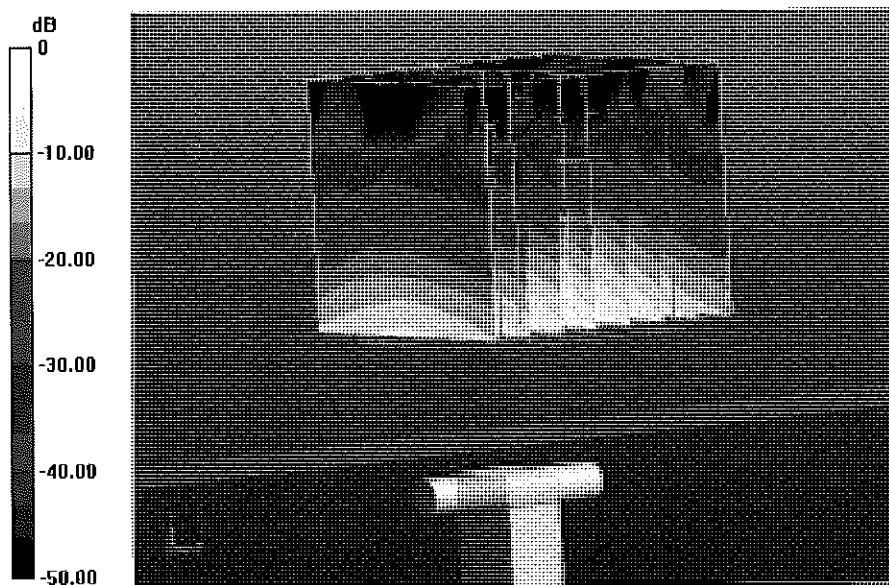

0 dB = 18.8 W/kg = 12.74 dBW/kg

# Impedance Measurement Plot for Head TSL

8 Feb 2013 10:10:29

CH1 S11 1 U FS 1: 53.764  $\Omega$  -6.3086  $\Omega$  4.8516 pF 5 200.000 000 MHz

\*  
De1  
Cor  
Avg  
0  
H1d

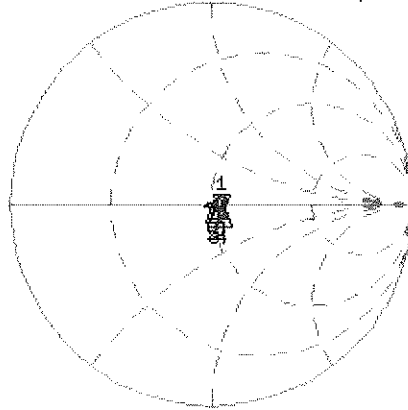

CH1 Markers  
2: 50.104  $\Omega$   
0.5313  $\Omega$   
5.30000 GHz  
3: 50.959  $\Omega$   
-853.52 m $\Omega$   
5.50000 GHz  
4: 55.305  $\Omega$   
-902.34 m $\Omega$   
5.60000 GHz  
5: 53.500  $\Omega$   
3.3027  $\Omega$   
5.80000 GHz

CH2 S11 LOG 5 dB/REF -20 dB 1: -23.013 dB 5 200.000 000 MHz

Cor  
Avg  
0  
H1d

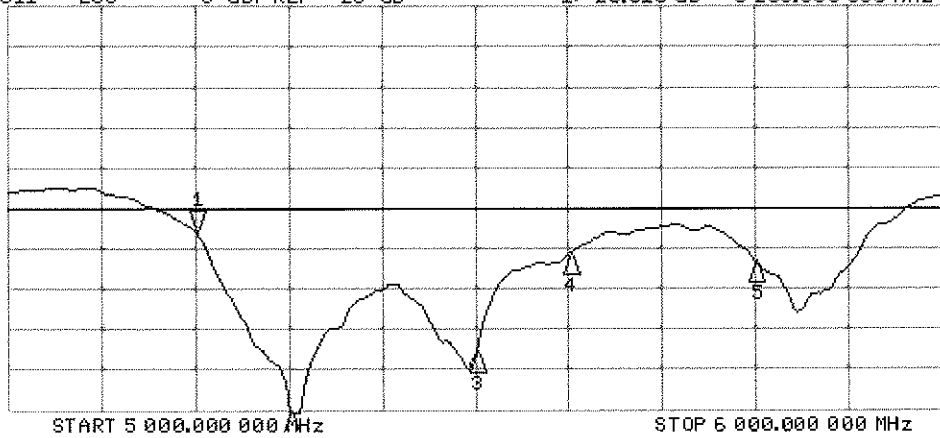

CH2 Markers  
2: -45.321 dB  
5.30000 GHz  
3: -37.887 dB  
5.50000 GHz  
4: -25.835 dB  
5.60000 GHz  
5: -26.651 dB  
5.80000 GHz

## DASY5 Validation Report for Body TSL

Date: 14.02.2013

Test Laboratory: SPEAG, Zurich, Switzerland

**DUT: Dipole 5GHz; Type: D5GHzV2; Serial: D5GHzV2 - SN: 1120**

Communication System: CW; Frequency: 5200 MHz, Frequency: 5300 MHz, Frequency: 5500 MHz, Frequency: 5600 MHz, Frequency: 5800 MHz

Medium parameters used:  $f = 5200$  MHz;  $\sigma = 5.36$  S/m;  $\epsilon_r = 46.9$ ;  $\rho = 1000$  kg/m<sup>3</sup>, Medium parameters used:  $f = 5300$  MHz;  $\sigma = 5.48$  S/m;  $\epsilon_r = 46.7$ ;  $\rho = 1000$  kg/m<sup>3</sup>, Medium parameters used:  $f = 5500$  MHz;  $\sigma = 5.71$  S/m;  $\epsilon_r = 46.3$ ;  $\rho = 1000$  kg/m<sup>3</sup>, Medium parameters used:  $f = 5600$  MHz;  $\sigma = 5.83$  S/m;  $\epsilon_r = 46.2$ ;  $\rho = 1000$  kg/m<sup>3</sup>, Medium parameters used:  $f = 5800$  MHz;  $\sigma = 6.12$  S/m;  $\epsilon_r = 45.9$ ;  $\rho = 1000$  kg/m<sup>3</sup>

Phantom section: Flat Section

Measurement Standard: DASY5 (IEEE/IEC/ANSI C63.19-2007)

DASY52 Configuration:

- Probe: EX3DV4 - SN3503; ConvF(4.91, 4.91, 4.91); Calibrated: 28.12.2012, ConvF(4.67, 4.67, 4.67); Calibrated: 28.12.2012, ConvF(4.43, 4.43, 4.43); Calibrated: 28.12.2012, ConvF(4.22, 4.22, 4.22); Calibrated: 28.12.2012, ConvF(4.38, 4.38, 4.38); Calibrated: 28.12.2012;
- Sensor-Surface: 1.4mm (Mechanical Surface Detection)
- Electronics: DAE4 Sn601; Calibrated: 27.06.2012
- Phantom: Flat Phantom 5.0 (back); Type: QD000P50AA; Serial: 1002
- DASY52 52.8.5(1059); SEMCAD X 14.6.8(7028)

**Dipole Calibration for Body Tissue/Pin=100mW, dist=10mm, f=5200 MHz/Zoom Scan,**

**dist=1.4mm (8x8x7)/Cube 0:** Measurement grid: dx=4mm, dy=4mm, dz=1.4mm

Reference Value = 61.053 V/m; Power Drift = -0.08 dB

Peak SAR (extrapolated) = 31.1 W/kg

**SAR(1 g) = 7.73 W/kg; SAR(10 g) = 2.17 W/kg**

Maximum value of SAR (measured) = 18.2 W/kg

**Dipole Calibration for Body Tissue/Pin=100mW, dist=10mm, f=5300 MHz/Zoom Scan,**

**dist=1.4mm (8x8x7)/Cube 0:** Measurement grid: dx=4mm, dy=4mm, dz=1.4mm

Reference Value = 60.021 V/m; Power Drift = -0.02 dB

Peak SAR (extrapolated) = 32.1 W/kg

**SAR(1 g) = 7.75 W/kg; SAR(10 g) = 2.18 W/kg**

Maximum value of SAR (measured) = 18.5 W/kg

**Dipole Calibration for Body Tissue/Pin=100mW, dist=10mm, f=5500 MHz/Zoom Scan,**

**dist=1.4mm (8x8x7)/Cube 0:** Measurement grid: dx=4mm, dy=4mm, dz=1.4mm

Reference Value = 59.894 V/m; Power Drift = -0.02 dB

Peak SAR (extrapolated) = 35.3 W/kg

**SAR(1 g) = 8.06 W/kg; SAR(10 g) = 2.24 W/kg**

Maximum value of SAR (measured) = 19.4 W/kg

**Dipole Calibration for Body Tissue/Pin=100mW, dist=10mm, f=5600 MHz/Zoom Scan,**

**dist=1.4mm (8x8x7)/Cube 0:** Measurement grid: dx=4mm, dy=4mm, dz=1.4mm

Reference Value = 59.730 V/m; Power Drift = -0.02 dB

Peak SAR (extrapolated) = 36.8 W/kg

**SAR(1 g) = 8.15 W/kg; SAR(10 g) = 2.26 W/kg**

Maximum value of SAR (measured) = 19.9 W/kg

**Dipole Calibration for Body Tissue/Pin=100mW, dist=10mm, f=5800 MHz/Zoom Scan,**

**dist=1.4mm (8x8x7)/Cube 0:** Measurement grid: dx=4mm, dy=4mm, dz=1.4mm

Reference Value = 56.663 V/m; Power Drift = -0.02 dB

Peak SAR (extrapolated) = 36.4 W/kg

**SAR(1 g) = 7.62 W/kg; SAR(10 g) = 2.12 W/kg**

Maximum value of SAR (measured) = 19.0 W/kg

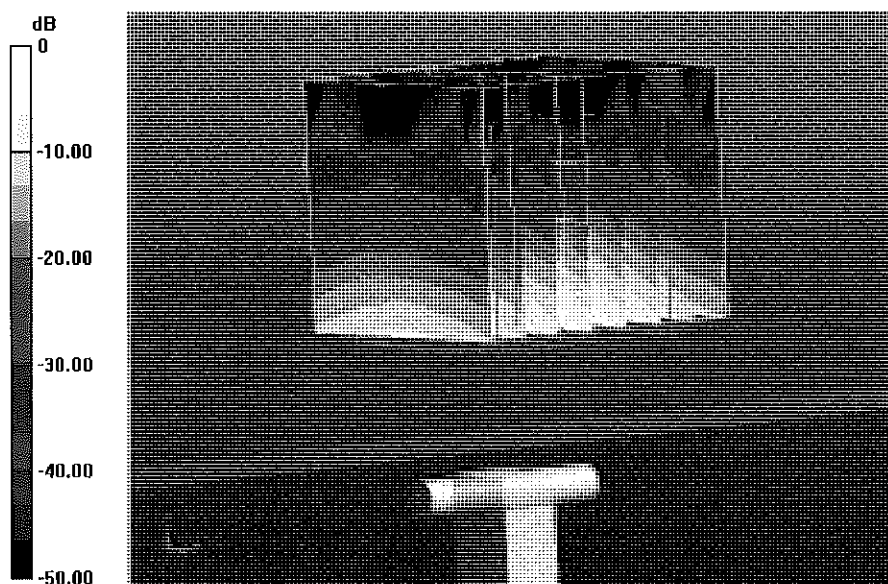

0 dB = 19.0 W/kg = 12.79 dBW/kg

# Impedance Measurement Plot for Body TSL

14 Feb 2013 15:47:05

CH1 S11 1 U FS 1: 53.672  $\Omega$  -4.7539  $\Omega$  6.4382 pF 5 200.000 000 MHz

\*  
De1  
Cor  
Avg  
16  
H1d

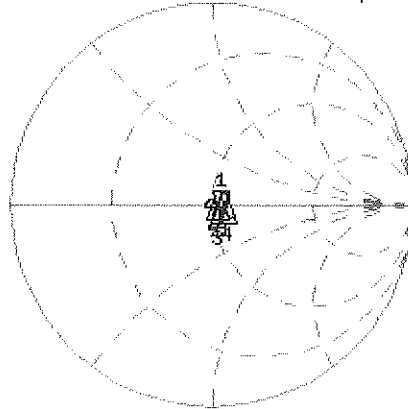

CH1 Markers  
2: 50.250  $\Omega$   
2.3555  $\Omega$   
5.30000 GHz  
3: 51.629  $\Omega$   
-1.4824  $\Omega$   
5.50000 GHz  
4: 57.389  $\Omega$   
0.9180  $\Omega$   
5.60000 GHz  
5: 53.543  $\Omega$   
3.2441  $\Omega$   
5.80000 GHz

CH2 S11 LOG 5 dB/REF -20 dB 1: -24.750 dB 5 200.000 000 MHz

Cor  
Avg  
16  
H1d

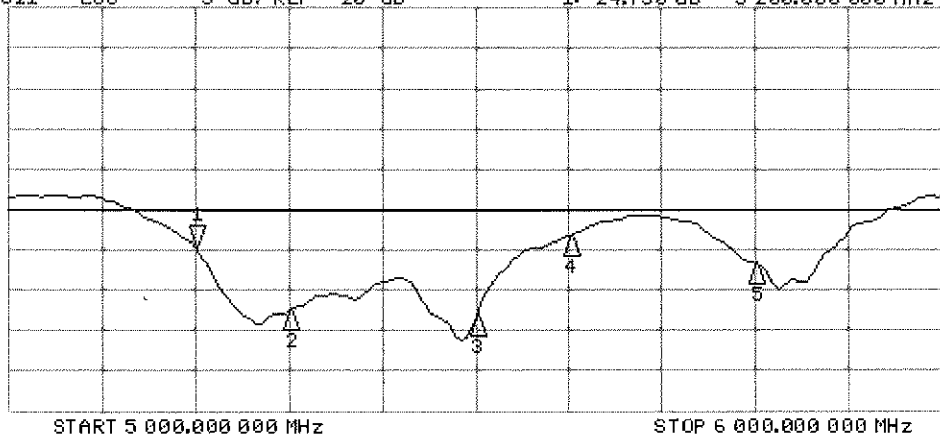

CH2 Markers  
2: -32.508 dB  
5.30000 GHz  
3: -33.267 dB  
5.50000 GHz  
4: -23.183 dB  
5.60000 GHz  
5: -26.672 dB  
5.80000 GHz

START 5 000.000 000 MHz

STOP 6 000.000 000 MHz

Calibration Laboratory of  
Schmid & Partner  
Engineering AG  
Zeughausstrasse 43, 8004 Zurich, Switzerland



SCS Schweizerischer Kalibrierdienst  
Service suisse d'étalonnage  
Servizio svizzero di taratura  
Swiss Calibration Service

Accredited by the Swiss Accreditation Service (SAS)  
The Swiss Accreditation Service is one of the signatories to the EA  
Multilateral Agreement for the recognition of calibration certificates

Accreditation No.: **SCS 108**

Client **PC Test**

Certificate No: **EX3-3914\_Oct13**

## CALIBRATION CERTIFICATE

Object: **EX3DV4 - SN:3914**

Calibration procedure(s): **DIA CAL-01 v3, GA CAL-14 v4, GA CAL-23 v5, DIA CAL-25 v6**  
*Calibration procedure for dielectric E-field probes*

Calibration date: **October 23, 2013** VCC  
11/20/2013

This calibration certificate documents the traceability to national standards, which realize the physical units of measurements (SI).  
The measurements and the uncertainties with confidence probability are given on the following pages and are part of the certificate.

All calibrations have been conducted in the closed laboratory facility: environment temperature (22 ± 3)°C and humidity < 70%.

Calibration Equipment used (M&TE critical for calibration)

| Primary Standards          | ID              | Cal Date (Certificate No.)        | Scheduled Calibration  |
|----------------------------|-----------------|-----------------------------------|------------------------|
| Power meter E4419B         | GB41293874      | 04-Apr-13 (No. 217-01733)         | Apr-14                 |
| Power sensor E4412A        | MY41498087      | 04-Apr-13 (No. 217-01733)         | Apr-14                 |
| Reference 3 dB Attenuator  | SN: S5054 (3c)  | 04-Apr-13 (No. 217-01737)         | Apr-14                 |
| Reference 20 dB Attenuator | SN: S5277 (20x) | 04-Apr-13 (No. 217-01735)         | Apr-14                 |
| Reference 30 dB Attenuator | SN: S5129 (30b) | 04-Apr-13 (No. 217-01738)         | Apr-14                 |
| Reference Probe ES3DV2     | SN: 3013        | 28-Dec-12 (No. ES3-3013_Dec12)    | Dec-13                 |
| DAE4                       | SN: 660         | 4-Sep-13 (No. DAE4-660_Sep13)     | Sep-14                 |
| Secondary Standards        | ID              | Check Date (in house)             | Scheduled Check        |
| RF generator HP 8648C      | US3642U01700    | 4-Aug-99 (in house check Apr-13)  | In house check: Apr-15 |
| Network Analyzer HP 8753E  | US37390585      | 18-Oct-01 (in house check Oct-13) | In house check: Oct-14 |

|                |               |                       |                          |
|----------------|---------------|-----------------------|--------------------------|
|                | Name          | Function              | Signature                |
| Calibrated by: | Leif Klysner  | Laboratory Technician |                          |
| Approved by:   | Katja Pokovic | Technical Manager     |                          |
|                |               |                       | Issued: October 25, 2013 |

This calibration certificate shall not be reproduced except in full without written approval of the laboratory.

PCT # 81072



Accredited by the Swiss Accreditation Service (SAS)  
 The Swiss Accreditation Service is one of the signatories to the EA  
 Multilateral Agreement for the recognition of calibration certificates

Accreditation No.: **SCS 108**

**Glossary:**

|                          |   |
|--------------------------|---|
| TSL                      | tissue simulating liquid  |
| NORM <sub>x,y,z</sub>    | sensitivity in free space   |
| ConvF                    | sensitivity in TSL / NORM <sub>x,y,z</sub>  |
| DCP                      | diode compression point   |
| CF                       | crest factor (1/duty_cycle) of the RF signal  |
| A, B, C, D               | modulation dependent linearization parameters   |
| Polarization $\varphi$   | $\varphi$ rotation around probe axis  |
| Polarization $\vartheta$ | $\vartheta$ rotation around an axis that is in the plane normal to probe axis (at measurement center),<br>i.e., $\vartheta = 0$ is normal to probe axis |
| Connector Angle          | information used in DASY system to align probe sensor X to the robot coordinate system  |

**Calibration is Performed According to the Following Standards:**

- a) IEEE Std 1528-2013, "IEEE Recommended Practice for Determining the Peak Spatial-Averaged Specific Absorption Rate (SAR) in the Human Head from Wireless Communications Devices: Measurement Techniques", June 2013
- b) IEC 62209-1, "Procedure to measure the Specific Absorption Rate (SAR) for hand-held devices used in close proximity to the ear (frequency range of 300 MHz to 3 GHz)", February 2005

**Methods Applied and Interpretation of Parameters:**

- **NORM<sub>x,y,z</sub>**: Assessed for E-field polarization  $\vartheta = 0$  ( $f \leq 900$  MHz in TEM-cell;  $f > 1800$  MHz: R22 waveguide). NORM<sub>x,y,z</sub> are only intermediate values, i.e., the uncertainties of NORM<sub>x,y,z</sub> does not affect the E<sup>2</sup>-field uncertainty inside TSL (see below *ConvF*).
- **NORM(f)<sub>x,y,z</sub>** = NORM<sub>x,y,z</sub> \* *frequency\_response* (see Frequency Response Chart). This linearization is implemented in DASY4 software versions later than 4.2. The uncertainty of the frequency response is included in the stated uncertainty of *ConvF*.
- **DCP<sub>x,y,z</sub>**: DCP are numerical linearization parameters assessed based on the data of power sweep with CW signal (no uncertainty required). DCP does not depend on frequency nor media.
- **PAR**: PAR is the Peak to Average Ratio that is not calibrated but determined based on the signal characteristics
- **A<sub>x,y,z</sub>; B<sub>x,y,z</sub>; C<sub>x,y,z</sub>; D<sub>x,y,z</sub>; VR<sub>x,y,z</sub>; A, B, C, D** are numerical linearization parameters assessed based on the data of power sweep for specific modulation signal. The parameters do not depend on frequency nor media. VR is the maximum calibration range expressed in RMS voltage across the diode.
- **ConvF and Boundary Effect Parameters**: Assessed in flat phantom using E-field (or Temperature Transfer Standard for  $f \leq 800$  MHz) and inside waveguide using analytical field distributions based on power measurements for  $f > 800$  MHz. The same setups are used for assessment of the parameters applied for boundary compensation (alpha, depth) of which typical uncertainty values are given. These parameters are used in DASY4 software to improve probe accuracy close to the boundary. The sensitivity in TSL corresponds to NORM<sub>x,y,z</sub> \* *ConvF* whereby the uncertainty corresponds to that given for *ConvF*. A frequency dependent *ConvF* is used in DASY version 4.4 and higher which allows extending the validity from  $\pm 50$  MHz to  $\pm 100$  MHz.
- **Spherical isotropy (3D deviation from isotropy)**: in a field of low gradients realized using a flat phantom exposed by a patch antenna.
- **Sensor Offset**: The sensor offset corresponds to the offset of virtual measurement center from the probe tip (on probe axis). No tolerance required.
- **Connector Angle**: The angle is assessed using the information gained by determining the NORM<sub>x</sub> (no uncertainty required).

# Probe EX3DV4

## SN:3914

Manufactured: December 18, 2012  
Calibrated: October 23, 2013

Calibrated for DASY/EASY Systems  
(Note: non-compatible with DASY2 system!)

## DASY/EASY - Parameters of Probe: EX3DV4 - SN:3914

### Basic Calibration Parameters

|   | Sensor X | Sensor Y | Sensor Z | Unc (k=2)     |
|---|----------|----------|----------|---------------|
| Norm ( $\mu\text{V}/(\text{V}/\text{m})^2$ ) <sup>A</sup> | 0.47     | 0.49     | 0.51     | $\pm 10.1 \%$ |
| DCP (mV) <sup>B</sup>                                     | 99.2     | 98.9     | 98.2     |               |

### Modulation Calibration Parameters

| UID           | Communication System Name                |   | A<br>dB | B<br>dB $\sqrt{\mu\text{V}}$ | C    | D<br>dB | VR<br>mV | Unc <sup>E</sup><br>(k=2) |
|---------------|--|---|---------|------------------------------|------|---------|----------|---------------------------|
| 0             | CW                                       | X | 0.0     | 0.0                          | 1.0  | 0.00    | 158.3    | $\pm 3.0 \%$              |
|               |  | Y | 0.0     | 0.0                          | 1.0  |         | 154.6    |                           |
|               |  | Z | 0.0     | 0.0                          | 1.0  |         | 170.8    |                           |
| 10010-<br>CAA | SAR Validation (Square, 100ms, 10ms)     | X | 0.71    | 53.3                         | 6.1  | 10.00   | 48.4     | $\pm 2.5 \%$              |
|               |  | Y | 2.43    | 67.0                         | 13.8 |         | 39.9     |                           |
|               |  | Z | 4.18    | 68.7                         | 13.8 |         | 45.7     |                           |
| 10011-<br>CAA | UMTS-FDD (WCDMA)                         | X | 3.05    | 64.4                         | 16.5 | 2.91    | 122.4    | $\pm 0.5 \%$              |
|               |  | Y | 3.31    | 66.5                         | 18.2 |         | 123.5    |                           |
|               |  | Z | 3.34    | 66.3                         | 17.8 |         | 136.6    |                           |
| 10012-<br>CAA | IEEE 802.11b WiFi 2.4 GHz (DSSS, 1 Mbps) | X | 2.49    | 64.8                         | 16.1 | 1.87    | 120.6    | $\pm 0.5 \%$              |
|               |  | Y | 2.94    | 68.6                         | 18.7 |         | 123.6    |                           |
|               |  | Z | 2.63    | 65.9                         | 17.0 |         | 135.4    |                           |
| 10021-<br>DAA | GSM-FDD (TDMA, GMSK)                     | X | 1.52    | 61.5                         | 10.9 | 9.39    | 83.6     | $\pm 1.2 \%$              |
|               |  | Y | 2.22    | 67.4                         | 15.0 |         | 116.0    |                           |
|               |  | Z | 2.47    | 66.8                         | 14.7 |         | 95.9     |                           |
| 10023-<br>DAA | GPRS-FDD (TDMA, GMSK, TN 0)              | X | 1.73    | 63.3                         | 11.9 | 9.57    | 81.5     | $\pm 1.7 \%$              |
|               |  | Y | 2.11    | 66.2                         | 14.2 |         | 111.8    |                           |
|               |  | Z | 2.76    | 69.0                         | 16.0 |         | 93.6     |                           |
| 10024-<br>DAA | GPRS-FDD (TDMA, GMSK, TN 0-1)            | X | 1.34    | 62.1                         | 9.4  | 6.56    | 121.0    | $\pm 1.2 \%$              |
|               |  | Y | 4.24    | 78.6                         | 17.9 |         | 130.0    |                           |
|               |  | Z | 2.91    | 70.7                         | 14.9 |         | 141.4    |                           |
| 10027-<br>DAA | GPRS-FDD (TDMA, GMSK, TN 0-1-2)          | X | 1.25    | 63.5                         | 9.7  | 4.80    | 143.5    | $\pm 1.4 \%$              |
|               |  | Y | 1.59    | 66.9                         | 12.2 |         | 149.7    |                           |
|               |  | Z | 2.98    | 71.5                         | 14.0 |         | 123.3    |                           |
| 10028-<br>DAA | GPRS-FDD (TDMA, GMSK, TN 0-1-2-3)        | X | 0.51    | 58.3                         | 7.4  | 3.55    | 113.4    | $\pm 1.2 \%$              |
|               |  | Y | 25.43   | 100.0                        | 22.6 |         | 121.3    |                           |
|               |  | Z | 38.67   | 97.5                         | 20.6 |         | 133.3    |                           |
| 10032-<br>CAA | IEEE 802.15.1 Bluetooth (GFSK, DH5)      | X | 0.28    | 58.6                         | 5.3  | 1.16    | 134.7    | $\pm 0.9 \%$              |
|               |  | Y | 65.75   | 99.6                         | 18.6 |         | 141.3    |                           |
|               |  | Z | 0.20    | 55.6                         | 4.1  |         | 112.1    |                           |
| 10039-<br>CAA | CDMA2000 (1xRTT, RC1)                    | X | 4.33    | 64.6                         | 17.4 | 4.57    | 113.8    | $\pm 0.7 \%$              |
|               |  | Y | 4.55    | 66.0                         | 18.6 |         | 120.8    |                           |
|               |  | Z | 4.85    | 66.2                         | 18.4 |         | 135.9    |                           |
| 10062-<br>CAA | IEEE 802.11a/h WiFi 5 GHz (OFDM, 6 Mbps) | X | 9.83    | 67.6                         | 20.7 | 8.68    | 109.0    | $\pm 2.5 \%$              |
|               |  | Y | 10.06   | 68.4                         | 21.5 |         | 118.2    |                           |
|               |  | Z | 10.66   | 69.2                         | 21.7 |         | 134.0    |                           |

|           |   |   |       |      |      |      |       |        |
|-----------|---|---|-------|------|------|------|-------|--------|
| 10081-CAA | CDMA2000 (1xRTT, RC3)                         | X | 3.59  | 63.9 | 16.9 | 3.97 | 113.6 | ±0.7 % |
|           |   | Y | 3.84  | 65.6 | 18.2 |      | 119.6 |        |
|           |   | Z | 3.95  | 65.4 | 17.8 |      | 134.5 |        |
| 10098-CAA | UMTS-FDD (HSUPA, Subtest 2)                   | X | 4.41  | 65.2 | 17.3 | 3.98 | 126.0 | ±0.7 % |
|           |   | Y | 4.73  | 66.9 | 18.6 |      | 132.5 |        |
|           |   | Z | 4.51  | 65.5 | 17.7 |      | 105.6 |        |
| 10100-CAB | LTE-FDD (SC-FDMA, 100% RB, 20 MHz, QPSK)      | X | 6.26  | 66.2 | 18.6 | 5.67 | 130.5 | ±1.2 % |
|           |   | Y | 6.61  | 67.7 | 19.8 |      | 139.3 |        |
|           |   | Z | 6.21  | 66.0 | 18.7 |      | 107.7 |        |
| 10108-CAB | LTE-FDD (SC-FDMA, 100% RB, 10 MHz, QPSK)      | X | 6.13  | 65.8 | 18.6 | 5.80 | 126.3 | ±1.2 % |
|           |   | Y | 6.40  | 67.1 | 19.6 |      | 135.6 |        |
|           |   | Z | 6.10  | 65.5 | 18.5 |      | 107.4 |        |
| 10110-CAB | LTE-FDD (SC-FDMA, 100% RB, 5 MHz, QPSK)       | X | 5.78  | 65.3 | 18.3 | 5.75 | 123.1 | ±1.2 % |
|           |   | Y | 5.97  | 66.3 | 19.2 |      | 131.5 |        |
|           |   | Z | 5.86  | 65.3 | 18.4 |      | 104.9 |        |
| 10114-CAA | IEEE 802.11n (HT Greenfield, 13.5 Mbps, BPSK) | X | 9.92  | 67.7 | 20.3 | 8.10 | 115.7 | ±2.5 % |
|           |   | Y | 10.25 | 68.7 | 21.2 |      | 126.8 |        |
|           |   | Z | 10.71 | 69.4 | 21.3 |      | 146.0 |        |
| 10117-CAA | IEEE 802.11n (HT Mixed, 13.5 Mbps, BPSK)      | X | 9.95  | 67.8 | 20.3 | 8.07 | 116.6 | ±2.5 % |
|           |   | Y | 10.26 | 68.7 | 21.1 |      | 128.3 |        |
|           |   | Z | 10.70 | 69.4 | 21.3 |      | 146.9 |        |
| 10151-CAB | LTE-TDD (SC-FDMA, 50% RB, 20 MHz, QPSK)       | X | 7.19  | 67.3 | 21.5 | 9.28 | 145.0 | ±2.2 % |
|           |   | Y | 7.40  | 68.3 | 22.4 |      | 110.8 |        |
|           |   | Z | 7.79  | 68.4 | 22.0 |      | 128.0 |        |
| 10154-CAB | LTE-FDD (SC-FDMA, 50% RB, 10 MHz, QPSK)       | X | 5.79  | 65.3 | 18.3 | 5.75 | 124.2 | ±1.2 % |
|           |   | Y | 6.03  | 66.5 | 19.4 |      | 131.9 |        |
|           |   | Z | 6.29  | 66.9 | 19.3 |      | 149.7 |        |
| 10160-CAB | LTE-FDD (SC-FDMA, 50% RB, 15 MHz, QPSK)       | X | 6.23  | 65.9 | 18.6 | 5.82 | 128.3 | ±1.2 % |
|           |   | Y | 6.51  | 67.2 | 19.7 |      | 136.9 |        |
|           |   | Z | 6.24  | 65.7 | 18.6 |      | 107.3 |        |
| 10169-CAB | LTE-FDD (SC-FDMA, 1 RB, 20 MHz, QPSK)         | X | 4.83  | 66.0 | 18.9 | 5.73 | 147.5 | ±1.2 % |
|           |   | Y | 4.72  | 65.8 | 19.2 |      | 113.8 |        |
|           |   | Z | 5.03  | 66.1 | 19.1 |      | 129.7 |        |
| 10172-CAB | LTE-TDD (SC-FDMA, 1 RB, 20 MHz, QPSK)         | X | 5.83  | 69.2 | 22.8 | 9.21 | 149.9 | ±1.9 % |
|           |   | Y | 5.81  | 69.4 | 23.4 |      | 120.3 |        |
|           |   | Z | 6.38  | 70.0 | 23.2 |      | 137.2 |        |
| 10175-CAB | LTE-FDD (SC-FDMA, 1 RB, 10 MHz, QPSK)         | X | 4.86  | 66.1 | 18.9 | 5.72 | 149.8 | ±1.2 % |
|           |   | Y | 4.72  | 65.8 | 19.2 |      | 113.3 |        |
|           |   | Z | 5.09  | 66.4 | 19.1 |      | 126.0 |        |
| 10181-CAB | LTE-FDD (SC-FDMA, 1 RB, 15 MHz, QPSK)         | X | 4.83  | 66.0 | 18.9 | 5.72 | 146.3 | ±1.2 % |
|           |   | Y | 4.69  | 65.6 | 19.1 |      | 112.2 |        |
|           |   | Z | 5.02  | 66.1 | 19.0 |      | 125.1 |        |
| 10193-CAA | IEEE 802.11n (HT Greenfield, 6.5 Mbps, BPSK)  | X | 9.51  | 67.4 | 20.2 | 8.09 | 108.6 | ±2.5 % |
|           |   | Y | 9.72  | 68.1 | 20.9 |      | 118.2 |        |
|           |   | Z | 10.30 | 68.9 | 21.1 |      | 135.0 |        |

|           |   |   |       |      |      |      |       |        |
|-----------|---|---|-------|------|------|------|-------|--------|
| 10196-CAA | IEEE 802.11n (HT Mixed, 6.5 Mbps, BPSK)                   | X | 9.52  | 67.4 | 20.2 | 8.10 | 111.6 | ±2.5 % |
|           |   | Y | 9.79  | 68.3 | 21.1 |      | 121.3 |        |
|           |   | Z | 10.30 | 68.9 | 21.2 |      | 139.2 |        |
| 10219-CAA | IEEE 802.11n (HT Mixed, 7.2 Mbps, BPSK)                   | X | 9.47  | 67.4 | 20.2 | 8.03 | 111.8 | ±2.2 % |
|           |   | Y | 9.67  | 68.3 | 21.0 |      | 120.0 |        |
|           |   | Z | 10.20 | 68.9 | 21.1 |      | 138.0 |        |
| 10222-CAA | IEEE 802.11n (HT Mixed, 15 Mbps, BPSK)                    | X | 9.96  | 67.9 | 20.4 | 8.06 | 118.4 | ±2.5 % |
|           |   | Y | 10.25 | 68.8 | 21.2 |      | 128.2 |        |
|           |   | Z | 10.65 | 69.3 | 21.3 |      | 144.5 |        |
| 10225-CAA | UMTS-FDD (HSPA+)  | X | 6.96  | 66.7 | 18.9 | 5.97 | 140.0 | ±1.4 % |
|           |   | Y | 7.23  | 67.9 | 20.0 |      | 148.9 |        |
|           |   | Z | 7.03  | 66.4 | 18.9 |      | 115.6 |        |
| 10237-CAB | LTE-TDD (SC-FDMA, 1 RB, 10 MHz, QPSK)                     | X | 5.51  | 67.5 | 21.8 | 9.21 | 114.2 | ±1.9 % |
|           |   | Y | 5.82  | 69.4 | 23.4 |      | 123.0 |        |
|           |   | Z | 6.49  | 70.6 | 23.6 |      | 140.2 |        |
| 10252-CAB | LTE-TDD (SC-FDMA, 50% RB, 10 MHz, QPSK)                   | X | 6.83  | 67.1 | 21.4 | 9.24 | 136.6 | ±1.9 % |
|           |   | Y | 7.30  | 69.4 | 23.2 |      | 147.3 |        |
|           |   | Z | 7.36  | 68.1 | 22.0 |      | 117.5 |        |
| 10267-CAB | LTE-TDD (SC-FDMA, 100% RB, 10 MHz, QPSK)                  | X | 7.26  | 67.5 | 21.6 | 9.30 | 142.7 | ±1.9 % |
|           |   | Y | 7.44  | 68.4 | 22.4 |      | 110.5 |        |
|           |   | Z | 7.84  | 68.7 | 22.2 |      | 122.6 |        |
| 10274-CAA | UMTS-FDD (HSUPA, Subtest 5, 3GPP Rel8.10)                 | X | 5.86  | 66.2 | 18.2 | 4.87 | 135.4 | ±0.9 % |
|           |   | Y | 6.12  | 67.5 | 19.2 |      | 142.3 |        |
|           |   | Z | 5.91  | 65.9 | 18.2 |      | 107.6 |        |
| 10275-CAA | UMTS-FDD (HSUPA, Subtest 5, 3GPP Rel8.4)                  | X | 4.17  | 64.8 | 17.3 | 3.96 | 115.6 | ±0.7 % |
|           |   | Y | 4.42  | 66.4 | 18.5 |      | 124.6 |        |
|           |   | Z | 4.47  | 66.0 | 18.0 |      | 132.6 |        |
| 10291-AAA | CDMA2000, RC3, SO55, Full Rate                            | X | 3.36  | 64.7 | 17.1 | 3.46 | 109.4 | ±0.5 % |
|           |   | Y | 3.55  | 66.2 | 18.3 |      | 118.2 |        |
|           |   | Z | 3.60  | 65.6 | 17.7 |      | 120.9 |        |
| 10292-AAA | CDMA2000, RC3, SO32, Full Rate                            | X | 3.34  | 64.9 | 17.2 | 3.39 | 110.1 | ±0.5 % |
|           |   | Y | 3.57  | 66.7 | 18.5 |      | 121.0 |        |
|           |   | Z | 3.54  | 65.6 | 17.7 |      | 123.9 |        |
| 10297-AAA | LTE-FDD (SC-FDMA, 50% RB, 20 MHz, QPSK)                   | X | 6.14  | 65.8 | 18.6 | 5.81 | 125.1 | ±1.2 % |
|           |   | Y | 6.44  | 67.2 | 19.7 |      | 135.7 |        |
|           |   | Z | 6.52  | 67.0 | 19.3 |      | 142.2 |        |
| 10311-AAA | LTE-FDD (SC-FDMA, 100% RB, 15 MHz, QPSK)                  | X | 6.76  | 66.6 | 19.1 | 6.06 | 131.8 | ±1.4 % |
|           |   | Y | 7.03  | 67.8 | 20.0 |      | 142.5 |        |
|           |   | Z | 7.15  | 67.7 | 19.7 |      | 148.6 |        |
| 10315-AAA | IEEE 802.11b WiFi 2.4 GHz (DSSS, 1 Mbps, 96pc duty cycle) | X | 2.42  | 64.6 | 16.1 | 1.71 | 116.8 | ±0.5 % |
|           |   | Y | 3.00  | 69.3 | 19.0 |      | 126.9 |        |
|           |   | Z | 2.61  | 66.3 | 17.2 |      | 128.2 |        |
| 10317-AAA | IEEE 802.11a WiFi 5 GHz (OFDM, 6 Mbps, 96pc duty cycle)   | X | 9.71  | 67.6 | 20.5 | 8.36 | 111.7 | ±2.5 % |
|           |   | Y | 9.99  | 68.6 | 21.4 |      | 122.2 |        |
|           |   | Z | 10.38 | 68.9 | 21.3 |      | 129.5 |        |

|           |   |   |       |      |      |      |       |        |
|-----------|---|---|-------|------|------|------|-------|--------|
| 10400-AAA | IEEE 802.11ac WiFi (20MHz, 64-QAM, 99pc duty cycle) | X | 9.83  | 67.8 | 20.6 | 8.37 | 112.9 | ±2.5 % |
|           |   | Y | 10.09 | 68.7 | 21.4 |      | 123.9 |        |
|           |   | Z | 10.48 | 68.9 | 21.3 |      | 130.5 |        |
| 10402-AAA | IEEE 802.11ac WiFi (80MHz, 64-QAM, 99pc duty cycle) | X | 10.61 | 68.3 | 20.7 | 8.53 | 121.1 | ±2.5 % |
|           |   | Y | 11.25 | 70.0 | 21.9 |      | 135.4 |        |
|           |   | Z | 11.15 | 69.4 | 21.4 |      | 137.4 |        |
| 10403-AAA | CDMA2000 (1xEV-DO, Rev. 0)                          | X | 4.51  | 67.4 | 17.8 | 3.76 | 119.2 | ±0.5 % |
|           |   | Y | 4.91  | 69.5 | 19.3 |      | 128.3 |        |
|           |   | Z | 4.84  | 67.5 | 18.1 |      | 135.4 |        |
| 10404-AAA | CDMA2000 (1xEV-DO, Rev. A)                          | X | 4.51  | 67.7 | 18.0 | 3.77 | 117.4 | ±0.5 % |
|           |   | Y | 4.92  | 69.8 | 19.5 |      | 125.4 |        |
|           |   | Z | 4.71  | 67.3 | 18.0 |      | 131.9 |        |

The reported uncertainty of measurement is stated as the standard uncertainty of measurement multiplied by the coverage factor  $k=2$ , which for a normal distribution corresponds to a coverage probability of approximately 95%.

<sup>A</sup> The uncertainties of NormX,Y,Z do not affect the  $E^2$ -field uncertainty inside TSL (see Pages 8 and 9).

<sup>B</sup> Numerical linearization parameter: uncertainty not required.

<sup>E</sup> Uncertainty is determined using the max. deviation from linear response applying rectangular distribution and is expressed for the square of the field value.

## DASY/EASY - Parameters of Probe: EX3DV4 - SN:3914

### Calibration Parameter Determined in Head Tissue Simulating Media

| f (MHz) <sup>C</sup> | Relative Permittivity <sup>F</sup> | Conductivity (S/m) <sup>F</sup> | ConvF X | ConvF Y | ConvF Z | Alpha <sup>G</sup> | Depth <sup>G</sup> (mm) | Unct. (k=2) |
|----------------------|------------------------------------|---------------------------------|---------|---------|---------|--------------------|-------------------------|-------------|
| 750                  | 41.9                               | 0.89                            | 9.70    | 9.70    | 9.70    | 0.34               | 1.01                    | ± 12.0 %    |
| 835                  | 41.5                               | 0.90                            | 9.34    | 9.34    | 9.34    | 0.67               | 0.67                    | ± 12.0 %    |
| 1750                 | 40.1                               | 1.37                            | 7.99    | 7.99    | 7.99    | 0.79               | 0.56                    | ± 12.0 %    |
| 1900                 | 40.0                               | 1.40                            | 7.69    | 7.69    | 7.69    | 0.80               | 0.58                    | ± 12.0 %    |
| 2450                 | 39.2                               | 1.80                            | 6.95    | 6.95    | 6.95    | 0.41               | 0.77                    | ± 12.0 %    |
| 2600                 | 39.0                               | 1.96                            | 6.79    | 6.79    | 6.79    | 0.40               | 0.82                    | ± 12.0 %    |
| 5200                 | 36.0                               | 4.66                            | 4.99    | 4.99    | 4.99    | 0.30               | 1.80                    | ± 13.1 %    |
| 5300                 | 35.9                               | 4.76                            | 4.82    | 4.82    | 4.82    | 0.30               | 1.80                    | ± 13.1 %    |
| 5500                 | 35.6                               | 4.96                            | 4.55    | 4.55    | 4.55    | 0.35               | 1.80                    | ± 13.1 %    |
| 5600                 | 35.5                               | 5.07                            | 4.37    | 4.37    | 4.37    | 0.35               | 1.80                    | ± 13.1 %    |
| 5800                 | 35.3                               | 5.27                            | 4.52    | 4.52    | 4.52    | 0.35               | 1.80                    | ± 13.1 %    |

<sup>C</sup> Frequency validity of ± 100 MHz only applies for DASY v4.4 and higher (see Page 2), else it is restricted to ± 50 MHz. The uncertainty is the RSS of the ConvF uncertainty at calibration frequency and the uncertainty for the indicated frequency band.

<sup>F</sup> At frequencies below 3 GHz, the validity of tissue parameters ( $\epsilon$  and  $\sigma$ ) can be relaxed to ± 10% if liquid compensation formula is applied to measured SAR values. At frequencies above 3 GHz, the validity of tissue parameters ( $\epsilon$  and  $\sigma$ ) is restricted to ± 5%. The uncertainty is the RSS of the ConvF uncertainty for indicated target tissue parameters.

<sup>G</sup> Alpha/Depth are determined during calibration. SPEAG warrants that the remaining deviation due to the boundary effect after compensation is always less than ± 1% for frequencies below 3 GHz and below ± 2% for frequencies between 3-6 GHz at any distance larger than half the probe tip diameter from the boundary.

## DASY/EASY - Parameters of Probe: EX3DV4 - SN:3914

### Calibration Parameter Determined in Body Tissue Simulating Media

| f (MHz) <sup>C</sup> | Relative Permittivity <sup>F</sup> | Conductivity (S/m) <sup>F</sup> | ConvF X | ConvF Y | ConvF Z | Alpha <sup>G</sup> | Depth <sup>G</sup> (mm) | Unct. (k=2) |
|----------------------|------------------------------------|---------------------------------|---------|---------|---------|--------------------|-------------------------|-------------|
| 750                  | 55.5                               | 0.96                            | 9.39    | 9.39    | 9.39    | 0.63               | 0.74                    | ± 12.0 %    |
| 835                  | 55.2                               | 0.97                            | 9.31    | 9.31    | 9.31    | 0.56               | 0.76                    | ± 12.0 %    |
| 1750                 | 53.4                               | 1.49                            | 7.89    | 7.89    | 7.89    | 0.32               | 1.03                    | ± 12.0 %    |
| 1900                 | 53.3                               | 1.52                            | 7.51    | 7.51    | 7.51    | 0.51               | 0.76                    | ± 12.0 %    |
| 2450                 | 52.7                               | 1.95                            | 7.02    | 7.02    | 7.02    | 0.80               | 0.50                    | ± 12.0 %    |
| 2600                 | 52.5                               | 2.16                            | 6.81    | 6.81    | 6.81    | 0.80               | 0.50                    | ± 12.0 %    |
| 5200                 | 49.0                               | 5.30                            | 4.52    | 4.52    | 4.52    | 0.35               | 1.90                    | ± 13.1 %    |
| 5300                 | 48.9                               | 5.42                            | 4.32    | 4.32    | 4.32    | 0.35               | 1.90                    | ± 13.1 %    |
| 5500                 | 48.6                               | 5.65                            | 4.07    | 4.07    | 4.07    | 0.35               | 1.90                    | ± 13.1 %    |
| 5600                 | 48.5                               | 5.77                            | 3.97    | 3.97    | 3.97    | 0.35               | 1.90                    | ± 13.1 %    |
| 5800                 | 48.2                               | 6.00                            | 4.14    | 4.14    | 4.14    | 0.40               | 1.90                    | ± 13.1 %    |

<sup>C</sup> Frequency validity of ± 100 MHz only applies for DASY v4.4 and higher (see Page 2), else it is restricted to ± 50 MHz. The uncertainty is the RSS of the ConvF uncertainty at calibration frequency and the uncertainty for the indicated frequency band.

<sup>F</sup> At frequencies below 3 GHz, the validity of tissue parameters ( $\epsilon$  and  $\sigma$ ) can be relaxed to ± 10% if liquid compensation formula is applied to measured SAR values. At frequencies above 3 GHz, the validity of tissue parameters ( $\epsilon$  and  $\sigma$ ) is restricted to ± 5%. The uncertainty is the RSS of the ConvF uncertainty for indicated target tissue parameters.

<sup>G</sup> Alpha/Depth are determined during calibration. SPEAG warrants that the remaining deviation due to the boundary effect after compensation is always less than ± 1% for frequencies below 3 GHz and below ± 2% for frequencies between 3-6 GHz at any distance larger than half the probe tip diameter from the boundary.

# Frequency Response of E-Field

(TEM-Cell:ifi110 EXX, Waveguide: R22)

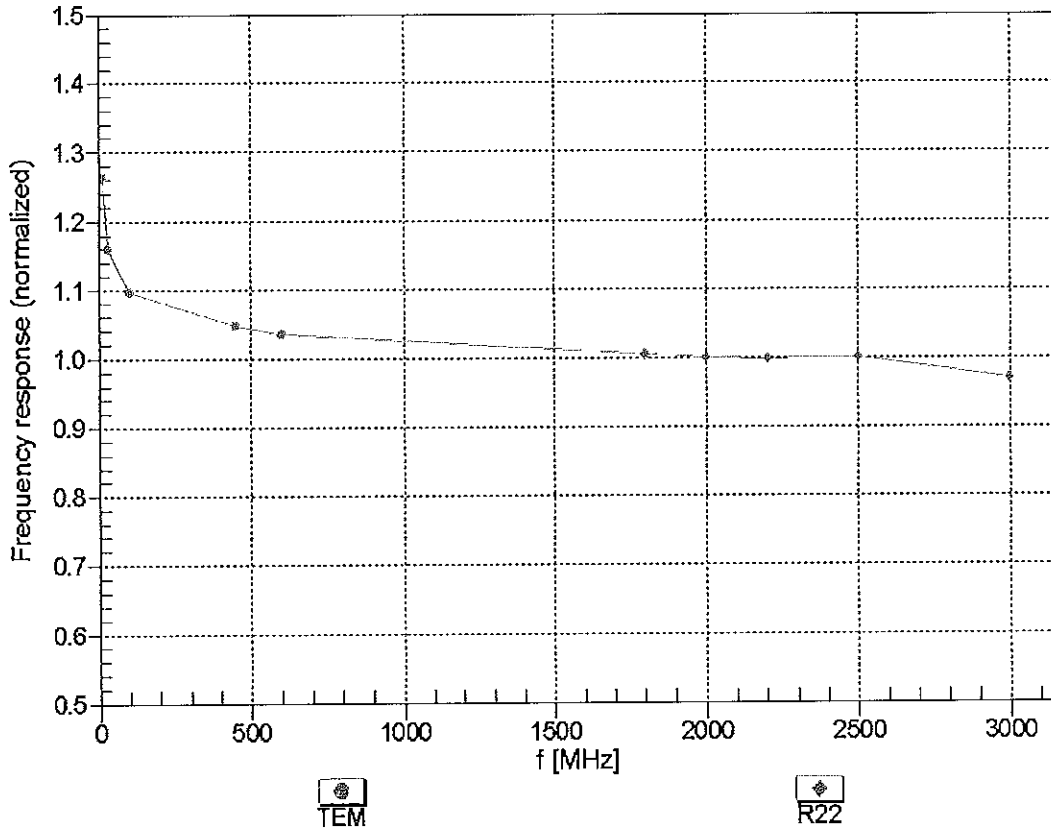

Uncertainty of Frequency Response of E-field:  $\pm 6.3\%$  (k=2)

### Receiving Pattern ( $\phi$ ), $\theta = 0^\circ$

f=600 MHz,TEM

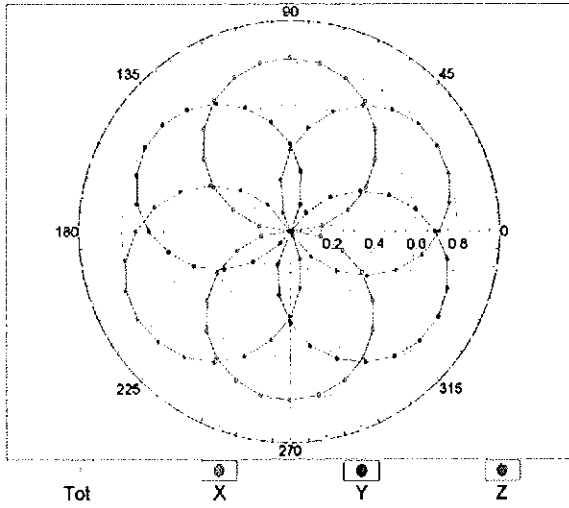

f=1800 MHz,R22

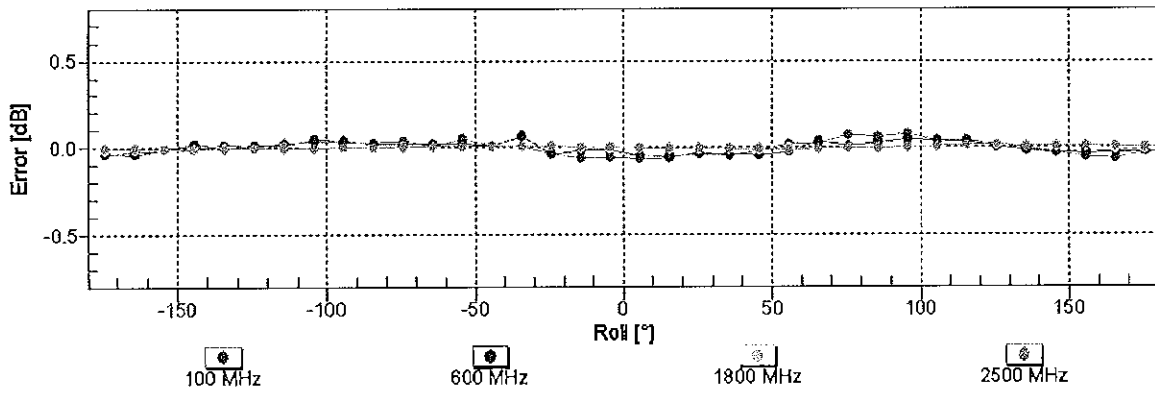
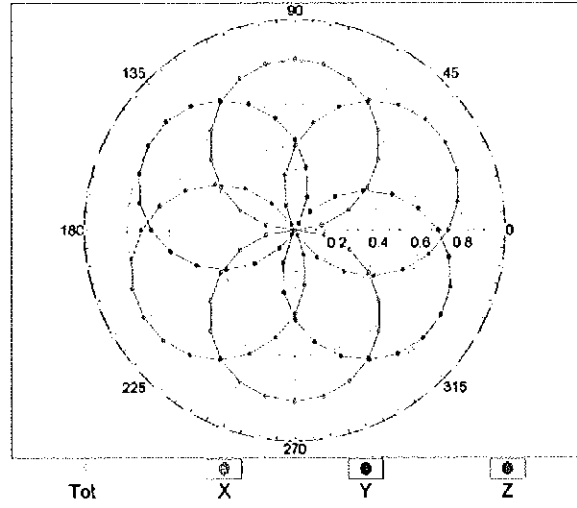

Uncertainty of Axial Isotropy Assessment:  $\pm 0.5\%$  (k=2)

### Dynamic Range $f(\text{SAR}_{\text{head}})$ (TEM cell , $f = 900 \text{ MHz}$ )

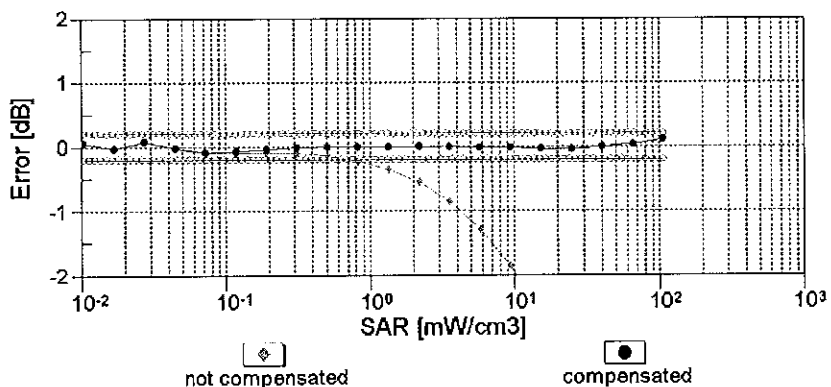
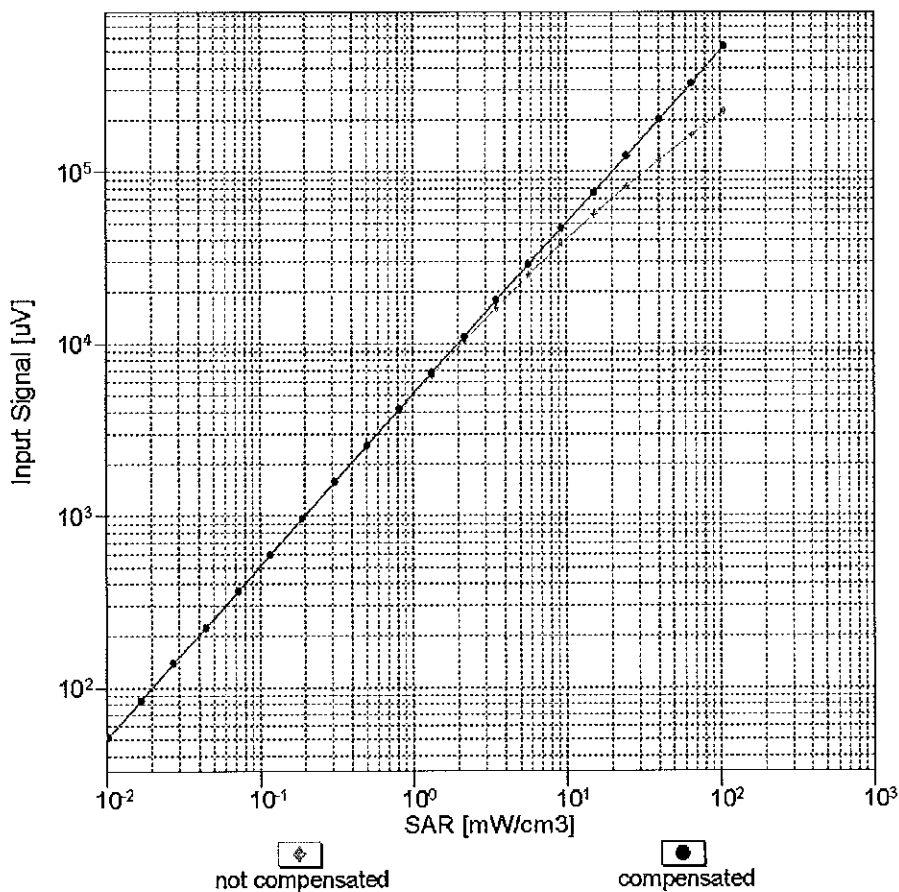

Uncertainty of Linearity Assessment:  $\pm 0.6\%$  ( $k=2$ )

# Conversion Factor Assessment

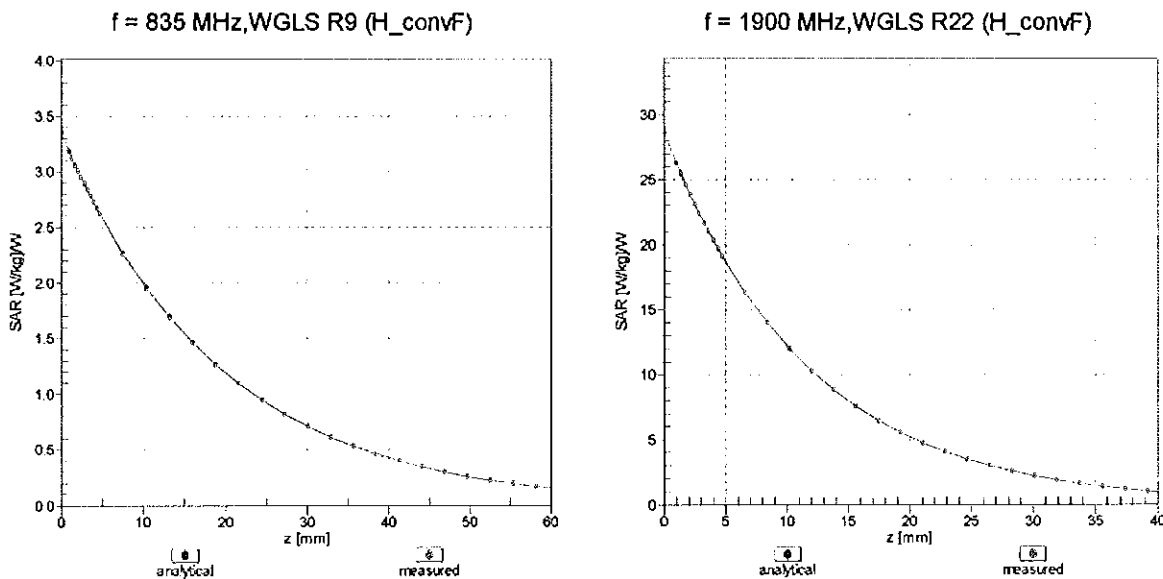

## Deviation from Isotropy in Liquid

Error ( $\phi, \theta$ ), f = 900 MHz

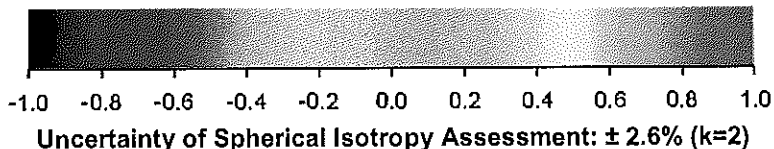
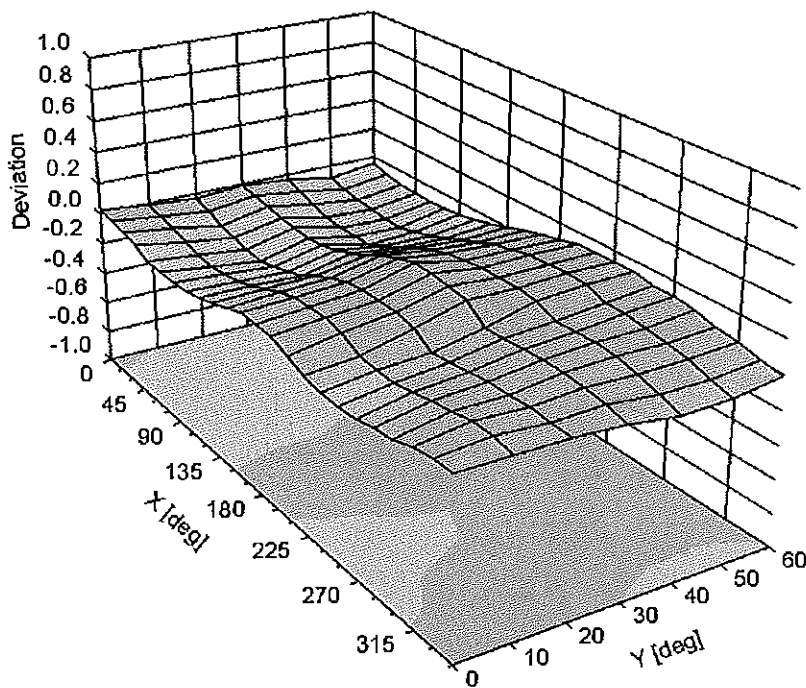

**DASY/EASY - Parameters of Probe: EX3DV4 - SN:3914****Other Probe Parameters**

|   |            |
|---|------------|
| Sensor Arrangement                            | Triangular |
| Connector Angle (°)                           | -24.3      |
| Mechanical Surface Detection Mode             | enabled    |
| Optical Surface Detection Mode                | disabled   |
| Probe Overall Length                          | 337 mm     |
| Probe Body Diameter                           | 10 mm      |
| Tip Length                                    | 9 mm       |
| Tip Diameter                                  | 2.5 mm     |
| Probe Tip to Sensor X Calibration Point       | 1 mm       |
| Probe Tip to Sensor Y Calibration Point       | 1 mm       |
| Probe Tip to Sensor Z Calibration Point       | 1 mm       |
| Recommended Measurement Distance from Surface | 2 mm       |



Accredited by the Swiss Accreditation Service (SAS)  
The Swiss Accreditation Service is one of the signatories to the EA  
Multilateral Agreement for the recognition of calibration certificates

Accreditation No.: **SCS 108**

Client **PC Test**

Certificate No: **ES3-3333\_Nov13**

**CALIBRATION CERTIFICATE**

Object **ES3DV3 - SN:3333**

Calibration procedure(s) **QA CAL 01.15, QA CAL 23.15, QA CAL 25.15  
Calibration procedure for dielectric E-field probes**

Calibration date: **November 22, 2013**

*KOK  
11/21/14*

This calibration certificate documents the traceability to national standards, which realize the physical units of measurements (SI).  
The measurements and the uncertainties with confidence probability are given on the following pages and are part of the certificate.

All calibrations have been conducted in the closed laboratory facility: environment temperature (22 ± 3)°C and humidity < 70%.

Calibration Equipment used (M&TE critical for calibration)

| Primary Standards          | ID              | Cal Date (Certificate No.)        | Scheduled Calibration  |
|----------------------------|-----------------|-----------------------------------|------------------------|
| Power meter E4419B         | GB41293874      | 04-Apr-13 (No. 217-01733)         | Apr-14                 |
| Power sensor E4412A        | MY41498087      | 04-Apr-13 (No. 217-01733)         | Apr-14                 |
| Reference 3 dB Attenuator  | SN: S5054 (3c)  | 04-Apr-13 (No. 217-01737)         | Apr-14                 |
| Reference 20 dB Attenuator | SN: S5277 (20x) | 04-Apr-13 (No. 217-01735)         | Apr-14                 |
| Reference 30 dB Attenuator | SN: S5129 (30b) | 04-Apr-13 (No. 217-01738)         | Apr-14                 |
| Reference Probe ES3DV2     | SN: 3013        | 28-Dec-12 (No. ES3-3013_Dec12)    | Dec-13                 |
| DAE4                       | SN: 660         | 4-Sep-13 (No. DAE4-660_Sep13)     | Sep-14                 |
| Secondary Standards        | ID              | Check Date (in house)             | Scheduled Check        |
| RF generator HP 8648C      | US3642U01700    | 4-Aug-99 (in house check Apr-13)  | In house check: Apr-15 |
| Network Analyzer HP 8753E  | US37390585      | 18-Oct-01 (in house check Oct-13) | In house check: Oct-14 |

|                | Name           | Function              | Signature          |
|----------------|----------------|-----------------------|--------------------|
| Calibrated by: | Jeton Kastrati | Laboratory Technician | <i>[Signature]</i> |
| Approved by:   | Katja Pokovic  | Technical Manager     | <i>[Signature]</i> |

Issued: November 25, 2013

This calibration certificate shell not be reproduced except in full without written approval of the laboratory.



Accredited by the Swiss Accreditation Service (SAS)

Accreditation No.: **SCS 108**

The Swiss Accreditation Service is one of the signatories to the EA  
Multilateral Agreement for the recognition of calibration certificates

### Glossary:

|                          |   |
|--------------------------|---|
| TSL                      | tissue simulating liquid  |
| NORM <sub>x,y,z</sub>    | sensitivity in free space   |
| ConvF                    | sensitivity in TSL / NORM <sub>x,y,z</sub>  |
| DCP                      | diode compression point   |
| CF                       | crest factor (1/duty_cycle) of the RF signal  |
| A, B, C, D               | modulation dependent linearization parameters   |
| Polarization $\phi$      | $\phi$ rotation around probe axis   |
| Polarization $\vartheta$ | $\vartheta$ rotation around an axis that is in the plane normal to probe axis (at measurement center),<br>i.e., $\vartheta = 0$ is normal to probe axis |
| Connector Angle          | information used in DASY system to align probe sensor X to the robot coordinate system  |

### Calibration is Performed According to the Following Standards:

- IEEE Std 1528-2013, "IEEE Recommended Practice for Determining the Peak Spatial-Averaged Specific Absorption Rate (SAR) in the Human Head from Wireless Communications Devices: Measurement Techniques", June 2013
- IEC 62209-1, "Procedure to measure the Specific Absorption Rate (SAR) for hand-held devices used in close proximity to the ear (frequency range of 300 MHz to 3 GHz)", February 2005

### Methods Applied and Interpretation of Parameters:

- NORM<sub>x,y,z</sub>**: Assessed for E-field polarization  $\vartheta = 0$  ( $f \leq 900$  MHz in TEM-cell;  $f > 1800$  MHz: R22 waveguide). NORM<sub>x,y,z</sub> are only intermediate values, i.e., the uncertainties of NORM<sub>x,y,z</sub> does not affect the E<sup>2</sup>-field uncertainty inside TSL (see below ConvF).
- NORM(f)<sub>x,y,z</sub>** = NORM<sub>x,y,z</sub> \* frequency\_response (see Frequency Response Chart). This linearization is implemented in DASY4 software versions later than 4.2. The uncertainty of the frequency response is included in the stated uncertainty of ConvF.
- DCP<sub>x,y,z</sub>**: DCP are numerical linearization parameters assessed based on the data of power sweep with CW signal (no uncertainty required). DCP does not depend on frequency nor media.
- PAR**: PAR is the Peak to Average Ratio that is not calibrated but determined based on the signal characteristics
- A<sub>x,y,z</sub>; B<sub>x,y,z</sub>; C<sub>x,y,z</sub>; D<sub>x,y,z</sub>; VR<sub>x,y,z</sub>; A, B, C, D** are numerical linearization parameters assessed based on the data of power sweep for specific modulation signal. The parameters do not depend on frequency nor media. VR is the maximum calibration range expressed in RMS voltage across the diode.
- ConvF and Boundary Effect Parameters**: Assessed in flat phantom using E-field (or Temperature Transfer Standard for  $f \leq 800$  MHz) and inside waveguide using analytical field distributions based on power measurements for  $f > 800$  MHz. The same setups are used for assessment of the parameters applied for boundary compensation (alpha, depth) of which typical uncertainty values are given. These parameters are used in DASY4 software to improve probe accuracy close to the boundary. The sensitivity in TSL corresponds to NORM<sub>x,y,z</sub> \* ConvF whereby the uncertainty corresponds to that given for ConvF. A frequency dependent ConvF is used in DASY version 4.4 and higher which allows extending the validity from  $\pm 50$  MHz to  $\pm 100$  MHz.
- Spherical isotropy (3D deviation from isotropy)**: in a field of low gradients realized using a flat phantom exposed by a patch antenna.
- Sensor Offset**: The sensor offset corresponds to the offset of virtual measurement center from the probe tip (on probe axis). No tolerance required.
- Connector Angle**: The angle is assessed using the information gained by determining the NORM<sub>x</sub> (no uncertainty required).

# Probe ES3DV3

## SN:3333

Manufactured: January 24, 2012  
Calibrated: November 22, 2013

Calibrated for DASY/EASY Systems  
(Note: non-compatible with DASY2 system!)

## DASY/EASY - Parameters of Probe: ES3DV3 - SN:3333

### Basic Calibration Parameters

|   | Sensor X | Sensor Y | Sensor Z | Unc (k=2)     |
|---|----------|----------|----------|---------------|
| Norm ( $\mu\text{V}/(\text{V}/\text{m})^2$ ) <sup>A</sup> | 1.08     | 0.90     | 0.88     | $\pm 10.1 \%$ |
| DCP (mV) <sup>B</sup>                                     | 104.9    | 103.3    | 101.7    |               |

### Modulation Calibration Parameters

| UID | Communication System Name |   | A<br>dB | B<br>dB $\sqrt{\mu\text{V}}$ | C   | D<br>dB | VR<br>mV | Unc <sup>E</sup><br>(k=2) |
|-----|---------------------------|---|---------|------------------------------|-----|---------|----------|---------------------------|
| 0   | CW                        | X | 0.0     | 0.0                          | 1.0 | 0.00    | 140.9    | $\pm 2.2 \%$              |
|     |                           | Y | 0.0     | 0.0                          | 1.0 |         | 132.0    |                           |
|     |                           | Z | 0.0     | 0.0                          | 1.0 |         | 170.3    |                           |

The reported uncertainty of measurement is stated as the standard uncertainty of measurement multiplied by the coverage factor  $k=2$ , which for a normal distribution corresponds to a coverage probability of approximately 95%.

<sup>A</sup> The uncertainties of NormX,Y,Z do not affect the  $E^2$ -field uncertainty inside TSL (see Pages 5 and 6).

<sup>B</sup> Numerical linearization parameter: uncertainty not required.

<sup>E</sup> Uncertainty is determined using the max. deviation from linear response applying rectangular distribution and is expressed for the square of the field value.

## DASY/EASY - Parameters of Probe: ES3DV3 - SN:3333

### Calibration Parameter Determined in Head Tissue Simulating Media

| f (MHz) <sup>C</sup> | Relative Permittivity <sup>F</sup> | Conductivity (S/m) <sup>F</sup> | ConvF X | ConvF Y | ConvF Z | Alpha <sup>G</sup> | Depth <sup>G</sup> (mm) | Unct. (k=2) |
|----------------------|------------------------------------|---------------------------------|---------|---------|---------|--------------------|-------------------------|-------------|
| 750                  | 41.9                               | 0.89                            | 6.56    | 6.56    | 6.56    | 0.44               | 1.54                    | ± 12.0 %    |
| 850                  | 41.5                               | 0.92                            | 6.30    | 6.30    | 6.30    | 0.46               | 1.48                    | ± 12.0 %    |
| 1750                 | 40.1                               | 1.37                            | 5.23    | 5.23    | 5.23    | 0.77               | 1.17                    | ± 12.0 %    |
| 1900                 | 40.0                               | 1.40                            | 5.05    | 5.05    | 5.05    | 0.80               | 1.19                    | ± 12.0 %    |
| 2450                 | 39.2                               | 1.80                            | 4.42    | 4.42    | 4.42    | 0.74               | 1.31                    | ± 12.0 %    |
| 2600                 | 39.0                               | 1.96                            | 4.28    | 4.28    | 4.28    | 0.80               | 1.30                    | ± 12.0 %    |

<sup>C</sup> Frequency validity of ± 100 MHz only applies for DASY v4.4 and higher (see Page 2), else it is restricted to ± 50 MHz. The uncertainty is the RSS of the ConvF uncertainty at calibration frequency and the uncertainty for the indicated frequency band.

<sup>F</sup> At frequencies below 3 GHz, the validity of tissue parameters ( $\epsilon$  and  $\sigma$ ) can be relaxed to ± 10% if liquid compensation formula is applied to measured SAR values. At frequencies above 3 GHz, the validity of tissue parameters ( $\epsilon$  and  $\sigma$ ) is restricted to ± 5%. The uncertainty is the RSS of the ConvF uncertainty for indicated target tissue parameters.

<sup>G</sup> Alpha/Depth are determined during calibration. SPEAG warrants that the remaining deviation due to the boundary effect after compensation is always less than ± 1% for frequencies below 3 GHz and below ± 2% for frequencies between 3-6 GHz at any distance larger than half the probe tip diameter from the boundary.

## DASY/EASY - Parameters of Probe: ES3DV3 - SN:3333

### Calibration Parameter Determined in Body Tissue Simulating Media

| f (MHz) <sup>C</sup> | Relative Permittivity <sup>F</sup> | Conductivity (S/m) <sup>F</sup> | ConvF X | ConvF Y | ConvF Z | Alpha <sup>G</sup> | Depth <sup>G</sup> (mm) | Unct. (k=2) |
|----------------------|------------------------------------|---------------------------------|---------|---------|---------|--------------------|-------------------------|-------------|
| 750                  | 55.5                               | 0.96                            | 6.11    | 6.11    | 6.11    | 0.33               | 1.90                    | ± 12.0 %    |
| 850                  | 55.2                               | 0.99                            | 6.07    | 6.07    | 6.07    | 0.80               | 1.19                    | ± 12.0 %    |
| 1750                 | 53.4                               | 1.49                            | 4.95    | 4.95    | 4.95    | 0.80               | 1.26                    | ± 12.0 %    |
| 1900                 | 53.3                               | 1.52                            | 4.71    | 4.71    | 4.71    | 0.49               | 1.54                    | ± 12.0 %    |
| 2450                 | 52.7                               | 1.95                            | 4.22    | 4.22    | 4.22    | 0.80               | 0.95                    | ± 12.0 %    |
| 2600                 | 52.5                               | 2.16                            | 4.16    | 4.16    | 4.16    | 0.80               | 1.07                    | ± 12.0 %    |

<sup>C</sup> Frequency validity of ± 100 MHz only applies for DASY v4.4 and higher (see Page 2), else it is restricted to ± 50 MHz. The uncertainty is the RSS of the ConvF uncertainty at calibration frequency and the uncertainty for the indicated frequency band.

<sup>F</sup> At frequencies below 3 GHz, the validity of tissue parameters ( $\epsilon$  and  $\sigma$ ) can be relaxed to ± 10% if liquid compensation formula is applied to measured SAR values. At frequencies above 3 GHz, the validity of tissue parameters ( $\epsilon$  and  $\sigma$ ) is restricted to ± 5%. The uncertainty is the RSS of the ConvF uncertainty for indicated target tissue parameters.

<sup>G</sup> Alpha/Depth are determined during calibration. SPEAG warrants that the remaining deviation due to the boundary effect after compensation is always less than ± 1% for frequencies below 3 GHz and below ± 2% for frequencies between 3-6 GHz at any distance larger than half the probe tip diameter from the boundary.

### Frequency Response of E-Field (TEM-Cell:ifi110 EXX, Waveguide: R22)

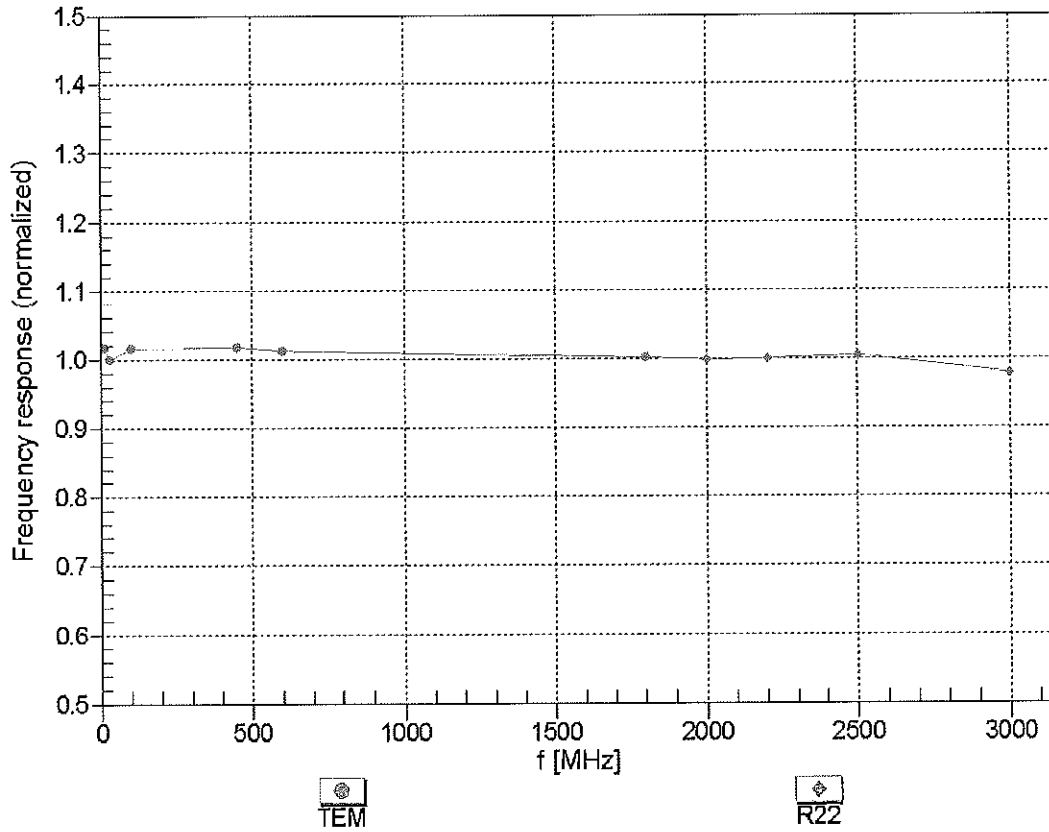

Uncertainty of Frequency Response of E-field:  $\pm 6.3\%$  (k=2)

### Receiving Pattern ( $\phi$ ), $\theta = 0^\circ$

f=600 MHz,TEM

f=1800 MHz,R22

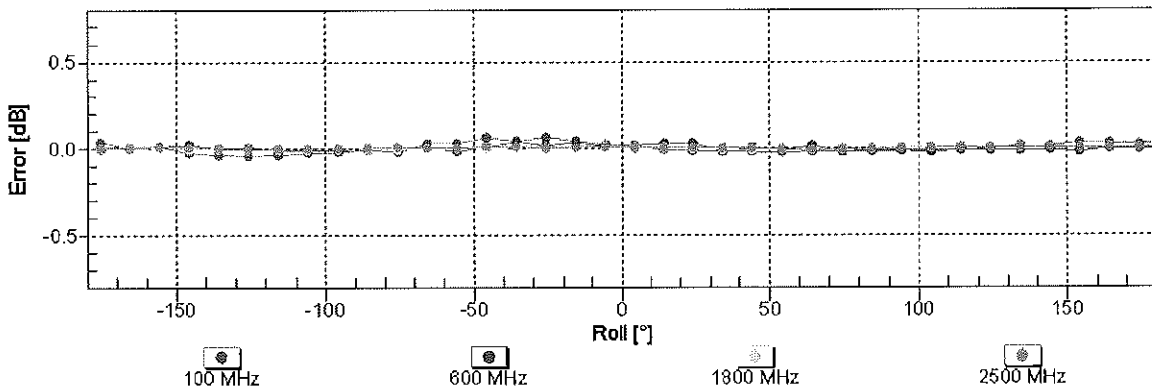
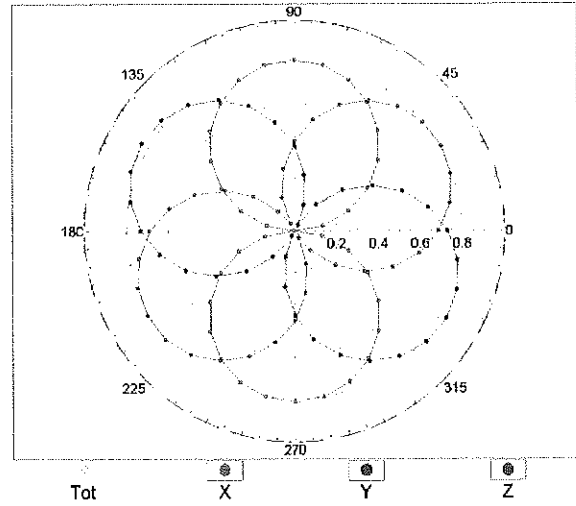
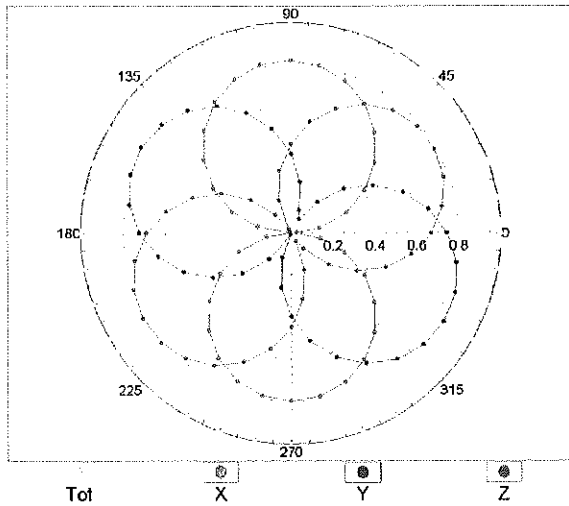

Uncertainty of Axial Isotropy Assessment:  $\pm 0.5\%$  (k=2)

### Dynamic Range $f(\text{SAR}_{\text{head}})$ (TEM cell , $f = 900 \text{ MHz}$ )

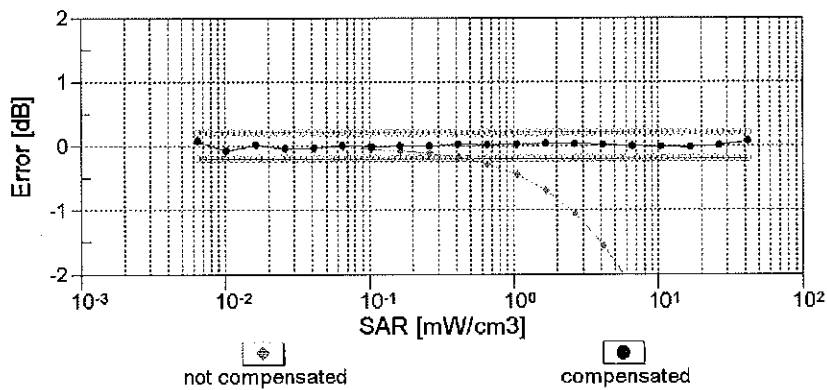
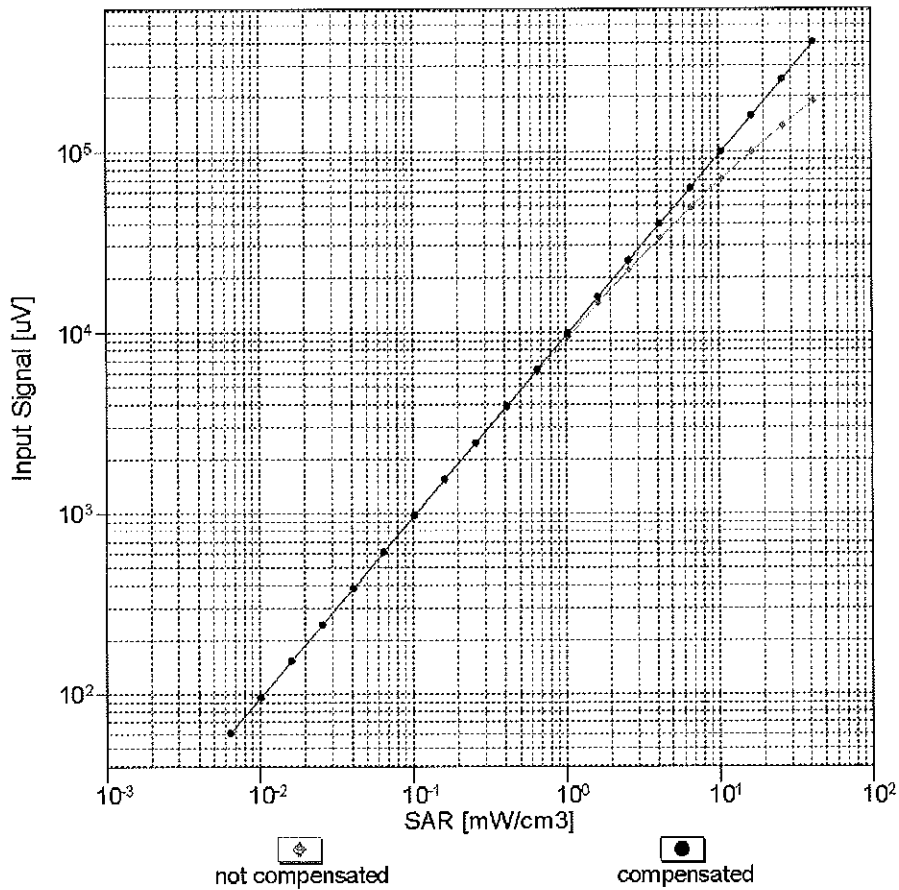

Uncertainty of Linearity Assessment:  $\pm 0.6\%$  ( $k=2$ )

# Conversion Factor Assessment

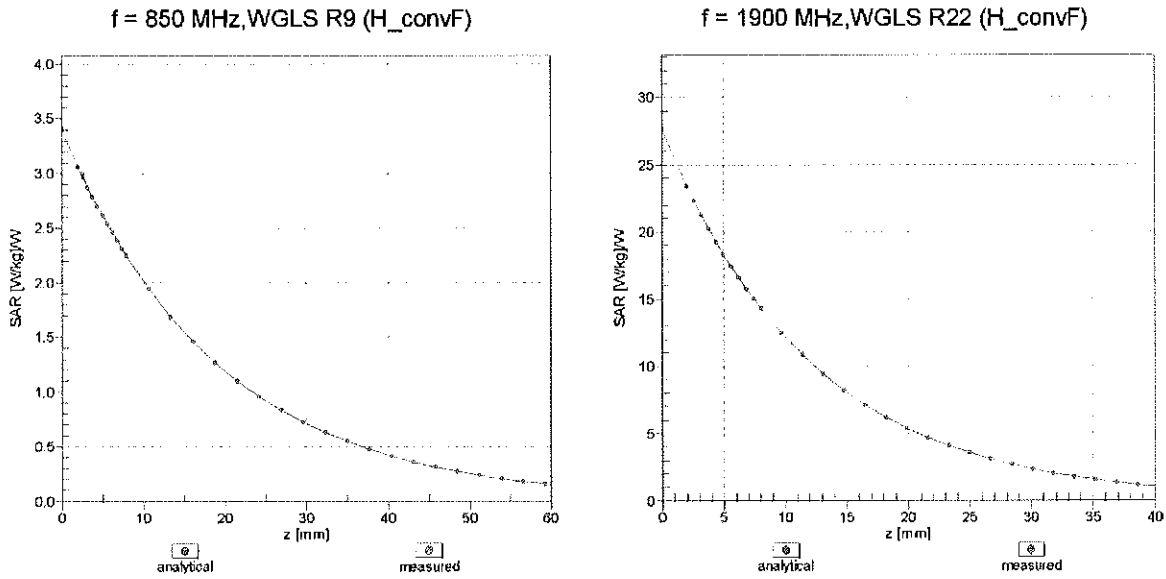

## Deviation from Isotropy in Liquid Error ( $\phi, \theta$ ), f = 900 MHz

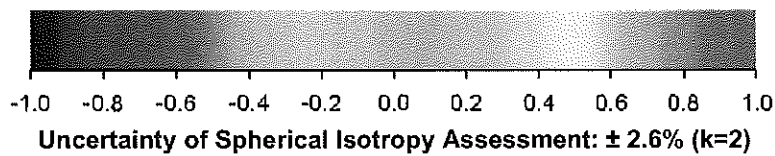
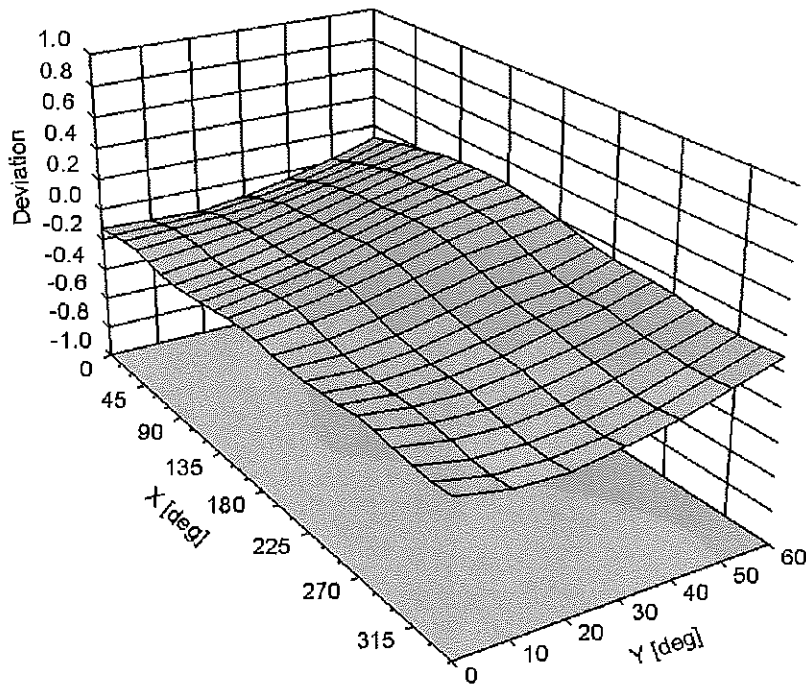

## DASY/EASY - Parameters of Probe: ES3DV3 - SN:3333

### Other Probe Parameters

|   |            |
|---|------------|
| Sensor Arrangement                            | Triangular |
| Connector Angle (°)                           | -35.7      |
| Mechanical Surface Detection Mode             | enabled    |
| Optical Surface Detection Mode                | disabled   |
| Probe Overall Length                          | 337 mm     |
| Probe Body Diameter                           | 10 mm      |
| Tip Length                                    | 10 mm      |
| Tip Diameter                                  | 4 mm       |
| Probe Tip to Sensor X Calibration Point       | 2 mm       |
| Probe Tip to Sensor Y Calibration Point       | 2 mm       |
| Probe Tip to Sensor Z Calibration Point       | 2 mm       |
| Recommended Measurement Distance from Surface | 3 mm       |



Accredited by the Swiss Accreditation Service (SAS)  
The Swiss Accreditation Service is one of the signatories to the EA  
Multilateral Agreement for the recognition of calibration certificates

Accreditation No.: **SCS 108**

Client **PC Test**

Certificate No: **D2450V2-882\_Feb13**

## CALIBRATION CERTIFICATE

Object **D2450V2 - SN: 882**

Calibration procedure(s) **QA CAL-05.v9  
Calibration procedure for dipole validation kits above 700 MHz**

Calibration date: **February 11, 2013**

*KOK  
2/21/13*

This calibration certificate documents the traceability to national standards, which realize the physical units of measurements (SI).  
The measurements and the uncertainties with confidence probability are given on the following pages and are part of the certificate.

All calibrations have been conducted in the closed laboratory facility: environment temperature ( $22 \pm 3$ )°C and humidity < 70%.

Calibration Equipment used (M&TE critical for calibration)

| Primary Standards           | ID #               | Cal Date (Certificate No.)     | Scheduled Calibration |
|-----------------------------|--------------------|--------------------------------|-----------------------|
| Power meter EPM-442A        | GB37480704         | 01-Nov-12 (No. 217-01640)      | Oct-13                |
| Power sensor HP 8481A       | US37292783         | 01-Nov-12 (No. 217-01640)      | Oct-13                |
| Reference 20 dB Attenuator  | SN: 5058 (20k)     | 27-Mar-12 (No. 217-01530)      | Apr-13                |
| Type-N mismatch combination | SN: 5047.3 / 06327 | 27-Mar-12 (No. 217-01533)      | Apr-13                |
| Reference Probe ES3DV3      | SN: 3205           | 28-Dec-12 (No. ES3-3205_Dec12) | Dec-13                |
| DAE4                        | SN: 601            | 27-Jun-12 (No. DAE4-601_Jun12) | Jun-13                |

| Secondary Standards       | ID #             | Check Date (in house)             | Scheduled Check        |
|---------------------------|------------------|-----------------------------------|------------------------|
| Power sensor HP 8481A     | MY41092317       | 18-Oct-02 (in house check Oct-11) | In house check: Oct-13 |
| RF generator R&S SMT-06   | 100005           | 04-Aug-99 (in house check Oct-11) | In house check: Oct-13 |
| Network Analyzer HP 8753E | US37390585 S4206 | 18-Oct-01 (in house check Oct-12) | In house check: Oct-13 |

Calibrated by: **Israe El-Naouq**      Name: **Israe El-Naouq**      Function: **Laboratory Technician**

Approved by: **Katja Pokovic**      Name: **Katja Pokovic**      Technical Manager

Signature  
*Israe El-Naouq*  
*Katja Pokovic*

Issued: February 11, 2013

This calibration certificate shall not be reproduced except in full without written approval of the laboratory.



Accredited by the Swiss Accreditation Service (SAS)  
The Swiss Accreditation Service is one of the signatories to the EA  
Multilateral Agreement for the recognition of calibration certificates

Accreditation No.: **SCS 108**

**Glossary:**

|       |                                 |
|-------|---------------------------------|
| TSL   | tissue simulating liquid        |
| ConvF | sensitivity in TSL / NORM x,y,z |
| N/A   | not applicable or not measured  |

**Calibration is Performed According to the Following Standards:**

- a) IEEE Std 1528-2003, "IEEE Recommended Practice for Determining the Peak Spatial-Averaged Specific Absorption Rate (SAR) in the Human Head from Wireless Communications Devices: Measurement Techniques", December 2003
- b) IEC 62209-1, "Procedure to measure the Specific Absorption Rate (SAR) for hand-held devices used in close proximity to the ear (frequency range of 300 MHz to 3 GHz)", February 2005
- c) Federal Communications Commission Office of Engineering & Technology (FCC OET), "Evaluating Compliance with FCC Guidelines for Human Exposure to Radiofrequency Electromagnetic Fields; Additional Information for Evaluating Compliance of Mobile and Portable Devices with FCC Limits for Human Exposure to Radiofrequency Emissions", Supplement C (Edition 01-01) to Bulletin 65

**Additional Documentation:**

- d) DASY4/5 System Handbook

**Methods Applied and Interpretation of Parameters:**

- *Measurement Conditions:* Further details are available from the Validation Report at the end of the certificate. All figures stated in the certificate are valid at the frequency indicated.
- *Antenna Parameters with TSL:* The dipole is mounted with the spacer to position its feed point exactly below the center marking of the flat phantom section, with the arms oriented parallel to the body axis.
- *Feed Point Impedance and Return Loss:* These parameters are measured with the dipole positioned under the liquid filled phantom. The impedance stated is transformed from the measurement at the SMA connector to the feed point. The Return Loss ensures low reflected power. No uncertainty required.
- *Electrical Delay:* One-way delay between the SMA connector and the antenna feed point. No uncertainty required.
- *SAR measured:* SAR measured at the stated antenna input power.
- *SAR normalized:* SAR as measured, normalized to an input power of 1 W at the antenna connector.
- *SAR for nominal TSL parameters:* The measured TSL parameters are used to calculate the nominal SAR result.

The reported uncertainty of measurement is stated as the standard uncertainty of measurement multiplied by the coverage factor  $k=2$ , which for a normal distribution corresponds to a coverage probability of approximately 95%.

## Measurement Conditions

DASY system configuration, as far as not given on page 1.

|                                     |                        |             |
|-------------------------------------|------------------------|-------------|
| <b>DASY Version</b>                 | DASY5                  | V52.8.5     |
| <b>Extrapolation</b>                | Advanced Extrapolation |             |
| <b>Phantom</b>                      | Modular Flat Phantom   |             |
| <b>Distance Dipole Center - TSL</b> | 10 mm                  | with Spacer |
| <b>Zoom Scan Resolution</b>         | dx, dy, dz = 5 mm      |             |
| <b>Frequency</b>                    | 2450 MHz $\pm$ 1 MHz   |             |

## Head TSL parameters

The following parameters and calculations were applied.

|  | Temperature         | Permittivity   | Conductivity         |
|--|---------------------|----------------|----------------------|
| <b>Nominal Head TSL parameters</b>             | 22.0 °C             | 39.2           | 1.80 mho/m           |
| <b>Measured Head TSL parameters</b>            | (22.0 $\pm$ 0.2) °C | 37.9 $\pm$ 6 % | 1.85 mho/m $\pm$ 6 % |
| <b>Head TSL temperature change during test</b> | < 0.5 °C            | ----           | ----                 |

## SAR result with Head TSL

| <b>SAR averaged over 1 cm<sup>3</sup> (1 g) of Head TSL</b> | Condition          |  |
|---|--------------------|--|
| SAR measured  | 250 mW input power | 13.2 W/kg                                      |
| SAR for nominal Head TSL parameters                         | normalized to 1W   | <b>51.7 W/kg <math>\pm</math> 17.0 % (k=2)</b> |

| <b>SAR averaged over 10 cm<sup>3</sup> (10 g) of Head TSL</b> | condition          |  |
|---|--------------------|--|
| SAR measured  | 250 mW input power | 6.07 W/kg                                      |
| SAR for nominal Head TSL parameters                           | normalized to 1W   | <b>24.0 W/kg <math>\pm</math> 16.5 % (k=2)</b> |

## Body TSL parameters

The following parameters and calculations were applied.

|  | Temperature         | Permittivity   | Conductivity         |
|--|---------------------|----------------|----------------------|
| <b>Nominal Body TSL parameters</b>             | 22.0 °C             | 52.7           | 1.95 mho/m           |
| <b>Measured Body TSL parameters</b>            | (22.0 $\pm$ 0.2) °C | 50.9 $\pm$ 6 % | 2.02 mho/m $\pm$ 6 % |
| <b>Body TSL temperature change during test</b> | < 0.5 °C            | ----           | ----                 |

## SAR result with Body TSL

| <b>SAR averaged over 1 cm<sup>3</sup> (1 g) of Body TSL</b> | Condition          |  |
|---|--------------------|--|
| SAR measured  | 250 mW input power | 12.8 W/kg                                      |
| SAR for nominal Body TSL parameters                         | normalized to 1W   | <b>49.9 W/kg <math>\pm</math> 17.0 % (k=2)</b> |

| <b>SAR averaged over 10 cm<sup>3</sup> (10 g) of Body TSL</b> | condition          |  |
|---|--------------------|--|
| SAR measured  | 250 mW input power | 5.91 W/kg                                      |
| SAR for nominal Body TSL parameters                           | normalized to 1W   | <b>23.3 W/kg <math>\pm</math> 16.5 % (k=2)</b> |

## Appendix

### Antenna Parameters with Head TSL

|                                      |                                |
|--------------------------------------|--------------------------------|
| Impedance, transformed to feed point | 53.6 $\Omega$ - 0.4 j $\Omega$ |
| Return Loss                          | - 29.0 dB                      |

### Antenna Parameters with Body TSL

|                                      |                                |
|--------------------------------------|--------------------------------|
| Impedance, transformed to feed point | 49.5 $\Omega$ + 1.2 j $\Omega$ |
| Return Loss                          | - 37.4 dB                      |

### General Antenna Parameters and Design

|                                  |          |
|----------------------------------|----------|
| Electrical Delay (one direction) | 1.157 ns |
|----------------------------------|----------|

After long term use with 100W radiated power, only a slight warming of the dipole near the feedpoint can be measured.

The dipole is made of standard semirigid coaxial cable. The center conductor of the feeding line is directly connected to the second arm of the dipole. The antenna is therefore short-circuited for DC-signals. On some of the dipoles, small end caps are added to the dipole arms in order to improve matching when loaded according to the position as explained in the "Measurement Conditions" paragraph. The SAR data are not affected by this change. The overall dipole length is still according to the Standard.

No excessive force must be applied to the dipole arms, because they might bend or the soldered connections near the feedpoint may be damaged.

### Additional EUT Data

|                 |                  |
|-----------------|------------------|
| Manufactured by | SPEAG            |
| Manufactured on | October 06, 2011 |

## DASY5 Validation Report for Head TSL

Date: 11.02.2013

Test Laboratory: SPEAG, Zurich, Switzerland

**DUT: Dipole 2450 MHz; Type: D2450V2; Serial: D2450V2 - SN: 882**

Communication System: CW; Frequency: 2450 MHz

Medium parameters used:  $f = 2450$  MHz;  $\sigma = 1.85$  S/m;  $\epsilon_r = 37.9$ ;  $\rho = 1000$  kg/m<sup>3</sup>

Phantom section: Flat Section

Measurement Standard: DASY5 (IEEE/IEC/ANSI C63.19-2007)

DASY52 Configuration:

- Probe: ES3DV3 - SN3205; ConvF(4.52, 4.52, 4.52); Calibrated: 28.12.2012;
- Sensor-Surface: 3mm (Mechanical Surface Detection)
- Electronics: DAE4 Sn601; Calibrated: 27.06.2012
- Phantom: Flat Phantom 5.0 (front); Type: QD000P50AA; Serial: 1001
- DASY52 52.8.5(1059); SEMCAD X 14.6.8(7028)

### Dipole Calibration for Head Tissue/Pin=250 mW, d=10mm/Zoom Scan (7x7x7)/Cube 0:

Measurement grid: dx=5mm, dy=5mm, dz=5mm

Reference Value = 97.806 V/m; Power Drift = 0.05 dB

Peak SAR (extrapolated) = 27.6 W/kg

**SAR(1 g) = 13.2 W/kg; SAR(10 g) = 6.07 W/kg**

Maximum value of SAR (measured) = 16.7 W/kg

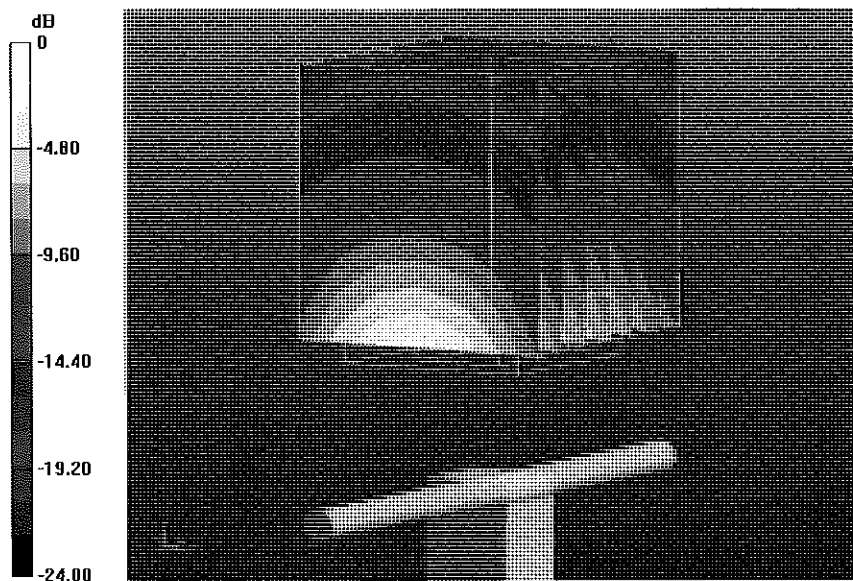

0 dB = 16.7 W/kg = 12.23 dBW/kg

# Impedance Measurement Plot for Head TSL

11 Feb 2013 11:51:51

CH1 S11 1 U FS 1: 53.639  $\Omega$  -363.28  $m\Omega$  178.82  $\mu F$  2 450.000 000 MHz

\*  
Del  
Cor  
Avg  
16  
H1d

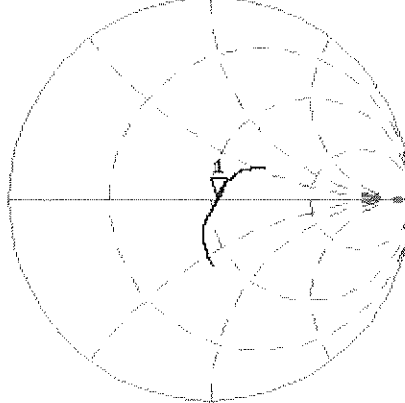

CH2 S11 LOG 5 dB/REF -20 dB 1:-29.047 dB 2 450.000 000 MHz

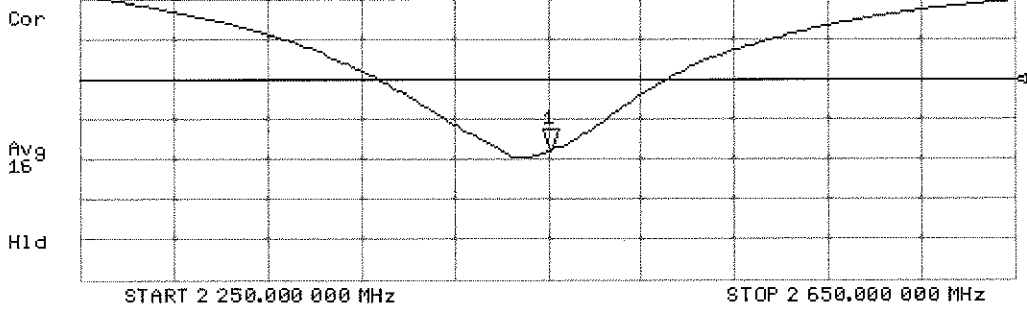

# DASY5 Validation Report for Body TSL

Date: 11.02.2013

Test Laboratory: SPEAG, Zurich, Switzerland

**DUT: Dipole 2450 MHz; Type: D2450V2; Serial: D2450V2 - SN: 882**

Communication System: CW; Frequency: 2450 MHz

Medium parameters used:  $f = 2450$  MHz;  $\sigma = 2.02$  S/m;  $\epsilon_r = 50.9$ ;  $\rho = 1000$  kg/m<sup>3</sup>

Phantom section: Flat Section

Measurement Standard: DASY5 (IEEE/IEC/ANSI C63.19-2007)

DASY52 Configuration:

- Probe: ES3DV3 - SN3205; ConvF(4.42, 4.42, 4.42); Calibrated: 28.12.2012;
- Sensor-Surface: 3mm (Mechanical Surface Detection)
- Electronics: DAE4 Sn601; Calibrated: 27.06.2012
- Phantom: Flat Phantom 5.0 (back); Type: QD000P50AA; Serial: 1002
- DASY52 52.8.5(1059); SEMCAD X 14.6.8(7028)

## Dipole Calibration for Body Tissue/Pin=250 mW, d=10mm/Zoom Scan (7x7x7)/Cube 0:

Measurement grid: dx=5mm, dy=5mm, dz=5mm

Reference Value = 94.474 V/m; Power Drift = 0.03 dB

Peak SAR (extrapolated) = 27.1 W/kg

**SAR(1 g) = 12.8 W/kg; SAR(10 g) = 5.91 W/kg**

Maximum value of SAR (measured) = 16.9 W/kg

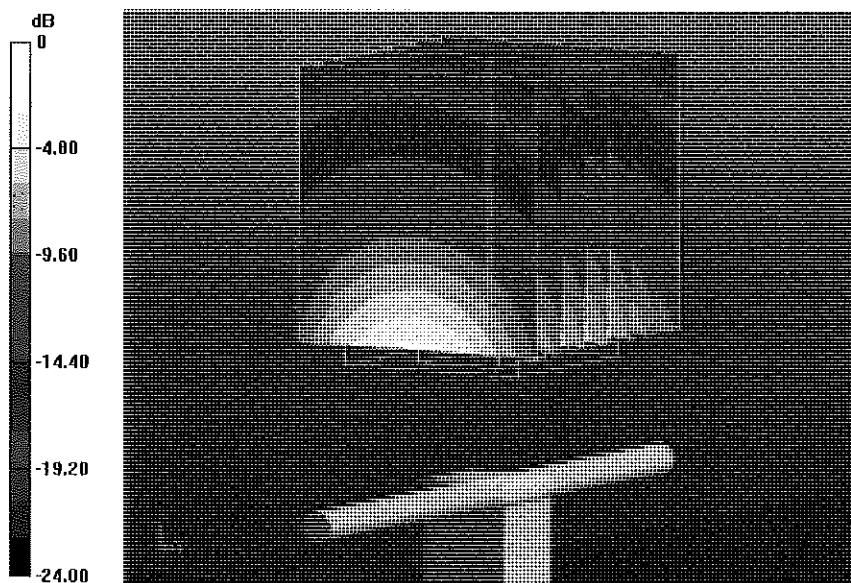

0 dB = 16.9 W/kg = 12.28 dBW/kg

# Impedance Measurement Plot for Body TSL

11 Feb 2013 11:51:25

CH1 S11 1 U FS 1: 49.500  $\Omega$  1.2461  $\Omega$  80.948 pF 2 450.000 000 MHz

\*  
De1  
Cor  
Avg  
16  
H1d

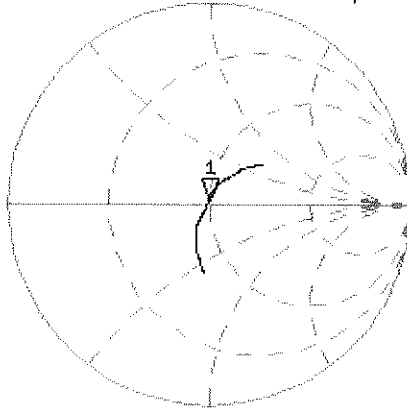

CH2 S11 LOG 5 dB/REF -20 dB 1: -37.374 dB 2 450.000 000 MHz

Cor  
Avg  
16  
H1d

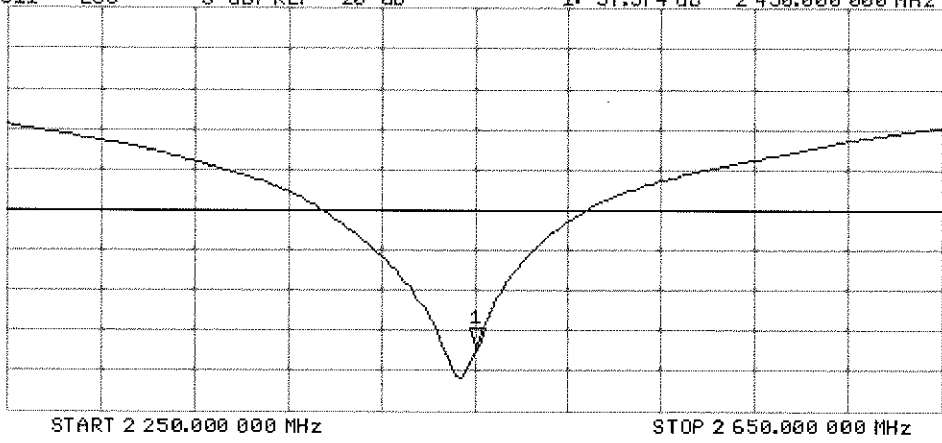



Accredited by the Swiss Accreditation Service (SAS)  
The Swiss Accreditation Service is one of the signatories to the EA  
Multilateral Agreement for the recognition of calibration certificates

Accreditation No.: **SCS 108**

Client **PC Test**

Certificate No: **D1900V2-5d149\_Jul13**

## CALIBRATION CERTIFICATE

Object **D1900V2 - SN: 5d149**

Calibration procedure(s) **QA CAL-05.v9  
Calibration procedure for dipole validation kits above 700 MHz**

Calibration date: **July 22, 2013**

*✓  
Kok  
8/19/13*

This calibration certificate documents the traceability to national standards, which realize the physical units of measurements (SI).  
The measurements and the uncertainties with confidence probability are given on the following pages and are part of the certificate.

All calibrations have been conducted in the closed laboratory facility: environment temperature (22 ± 3)°C and humidity < 70%.

Calibration Equipment used (M&TE critical for calibration)

| Primary Standards           | ID #               | Cal Date (Certificate No.)        | Scheduled Calibration  |
|-----------------------------|--------------------|-----------------------------------|------------------------|
| Power meter EPM-442A        | GB37480704         | 01-Nov-12 (No. 217-01640)         | Oct-13                 |
| Power sensor HP 8481A       | US37292783         | 01-Nov-12 (No. 217-01640)         | Oct-13                 |
| Reference 20 dB Attenuator  | SN: 5058 (20k)     | 04-Apr-13 (No. 217-01736)         | Apr-14                 |
| Type-N mismatch combination | SN: 5047.3 / 06327 | 04-Apr-13 (No. 217-01739)         | Apr-14                 |
| Reference Probe ES3DV3      | SN: 3205           | 28-Dec-12 (No. ES3-3205_Dec12)    | Dec-13                 |
| DAE4                        | SN: 601            | 25-Apr-13 (No. DAE4-601_Apr13)    | Apr-14                 |
| Secondary Standards         | ID #               | Check Date (in house)             | Scheduled Check        |
| Power sensor HP 8481A       | MY41092317         | 18-Oct-02 (in house check Oct-11) | In house check: Oct-13 |
| RF generator R&S SMT-06     | 100005             | 04-Aug-99 (in house check Oct-11) | In house check: Oct-13 |
| Network Analyzer HP 8753E   | US37390585 S4206   | 18-Oct-01 (in house check Oct-12) | In house check: Oct-13 |

|                |                |                       |                  |
|----------------|----------------|-----------------------|------------------|
|                | <b>Name</b>    | <b>Function</b>       | <b>Signature</b> |
| Calibrated by: | Jeton Kastrali | Laboratory Technician |                  |
| Approved by:   | Katja Pokovic  | Technical Manager     |                  |

Issued: July 22, 2013

This calibration certificate shall not be reproduced except in full without written approval of the laboratory.



Accredited by the Swiss Accreditation Service (SAS)  
The Swiss Accreditation Service is one of the signatories to the EA  
Multilateral Agreement for the recognition of calibration certificates

Accreditation No.: **SCS 108**

**Glossary:**

|       |                                 |
|-------|---------------------------------|
| TSL   | tissue simulating liquid        |
| ConvF | sensitivity in TSL / NORM x,y,z |
| N/A   | not applicable or not measured  |

**Calibration is Performed According to the Following Standards:**

- a) IEEE Std 1528-2003, "IEEE Recommended Practice for Determining the Peak Spatial-Averaged Specific Absorption Rate (SAR) in the Human Head from Wireless Communications Devices: Measurement Techniques", December 2003
- b) IEC 62209-1, "Procedure to measure the Specific Absorption Rate (SAR) for hand-held devices used in close proximity to the ear (frequency range of 300 MHz to 3 GHz)", February 2005
- c) Federal Communications Commission Office of Engineering & Technology (FCC OET), "Evaluating Compliance with FCC Guidelines for Human Exposure to Radiofrequency Electromagnetic Fields; Additional Information for Evaluating Compliance of Mobile and Portable Devices with FCC Limits for Human Exposure to Radiofrequency Emissions", Supplement C (Edition 01-01) to Bulletin 65

**Additional Documentation:**

- d) DASY4/5 System Handbook

**Methods Applied and Interpretation of Parameters:**

- *Measurement Conditions:* Further details are available from the Validation Report at the end of the certificate. All figures stated in the certificate are valid at the frequency indicated.
- *Antenna Parameters with TSL:* The dipole is mounted with the spacer to position its feed point exactly below the center marking of the flat phantom section, with the arms oriented parallel to the body axis.
- *Feed Point Impedance and Return Loss:* These parameters are measured with the dipole positioned under the liquid filled phantom. The impedance stated is transformed from the measurement at the SMA connector to the feed point. The Return Loss ensures low reflected power. No uncertainty required.
- *Electrical Delay:* One-way delay between the SMA connector and the antenna feed point. No uncertainty required.
- *SAR measured:* SAR measured at the stated antenna input power.
- *SAR normalized:* SAR as measured, normalized to an input power of 1 W at the antenna connector.
- *SAR for nominal TSL parameters:* The measured TSL parameters are used to calculate the nominal SAR result.

The reported uncertainty of measurement is stated as the standard uncertainty of measurement multiplied by the coverage factor  $k=2$ , which for a normal distribution corresponds to a coverage probability of approximately 95%.

## Measurement Conditions

DASY system configuration, as far as not given on page 1.

|                                     |                        |             |
|-------------------------------------|------------------------|-------------|
| <b>DASY Version</b>                 | DASY5                  | V52.8.7     |
| <b>Extrapolation</b>                | Advanced Extrapolation |             |
| <b>Phantom</b>                      | Modular Flat Phantom   |             |
| <b>Distance Dipole Center - TSL</b> | 10 mm                  | with Spacer |
| <b>Zoom Scan Resolution</b>         | dx, dy, dz = 5 mm      |             |
| <b>Frequency</b>                    | 1900 MHz $\pm$ 1 MHz   |             |

## Head TSL parameters

The following parameters and calculations were applied.

|  | Temperature         | Permittivity   | Conductivity         |
|--|---------------------|----------------|----------------------|
| <b>Nominal Head TSL parameters</b>             | 22.0 °C             | 40.0           | 1.40 mho/m           |
| <b>Measured Head TSL parameters</b>            | (22.0 $\pm$ 0.2) °C | 38.9 $\pm$ 6 % | 1.36 mho/m $\pm$ 6 % |
| <b>Head TSL temperature change during test</b> | < 0.5 °C            | ----           | ----                 |

## SAR result with Head TSL

| <b>SAR averaged over 1 cm<sup>3</sup> (1 g) of Head TSL</b> | Condition          |  |
|---|--------------------|--|
| SAR measured  | 250 mW input power | 9.99 W/kg                                      |
| SAR for nominal Head TSL parameters                         | normalized to 1W   | <b>40.4 W/kg <math>\pm</math> 17.0 % (k=2)</b> |

| <b>SAR averaged over 10 cm<sup>3</sup> (10 g) of Head TSL</b> | condition          |  |
|---|--------------------|--|
| SAR measured  | 250 mW input power | 5.28 W/kg                                      |
| SAR for nominal Head TSL parameters                           | normalized to 1W   | <b>21.3 W/kg <math>\pm</math> 16.5 % (k=2)</b> |

## Body TSL parameters

The following parameters and calculations were applied.

|  | Temperature         | Permittivity   | Conductivity         |
|--|---------------------|----------------|----------------------|
| <b>Nominal Body TSL parameters</b>             | 22.0 °C             | 53.3           | 1.52 mho/m           |
| <b>Measured Body TSL parameters</b>            | (22.0 $\pm$ 0.2) °C | 53.4 $\pm$ 6 % | 1.49 mho/m $\pm$ 6 % |
| <b>Body TSL temperature change during test</b> | < 0.5 °C            | ----           | ----                 |

## SAR result with Body TSL

| <b>SAR averaged over 1 cm<sup>3</sup> (1 g) of Body TSL</b> | Condition          |  |
|---|--------------------|--|
| SAR measured  | 250 mW input power | 10.0 W/kg                                      |
| SAR for nominal Body TSL parameters                         | normalized to 1W   | <b>40.5 W/kg <math>\pm</math> 17.0 % (k=2)</b> |

| <b>SAR averaged over 10 cm<sup>3</sup> (10 g) of Body TSL</b> | condition          |  |
|---|--------------------|--|
| SAR measured  | 250 mW input power | 5.36 W/kg                                      |
| SAR for nominal Body TSL parameters                           | normalized to 1W   | <b>21.6 W/kg <math>\pm</math> 16.5 % (k=2)</b> |

## Appendix

### Antenna Parameters with Head TSL

|                                      |                                |
|--------------------------------------|--------------------------------|
| Impedance, transformed to feed point | 52.9 $\Omega$ + 6.0 j $\Omega$ |
| Return Loss                          | - 23.8 dB                      |

### Antenna Parameters with Body TSL

|                                      |                                |
|--------------------------------------|--------------------------------|
| Impedance, transformed to feed point | 48.5 $\Omega$ + 6.4 j $\Omega$ |
| Return Loss                          | - 23.5 dB                      |

### General Antenna Parameters and Design

|                                  |          |
|----------------------------------|----------|
| Electrical Delay (one direction) | 1.196 ns |
|----------------------------------|----------|

After long term use with 100W radiated power, only a slight warming of the dipole near the feedpoint can be measured.

The dipole is made of standard semirigid coaxial cable. The center conductor of the feeding line is directly connected to the second arm of the dipole. The antenna is therefore short-circuited for DC-signals. On some of the dipoles, small end caps are added to the dipole arms in order to improve matching when loaded according to the position as explained in the "Measurement Conditions" paragraph. The SAR data are not affected by this change. The overall dipole length is still according to the Standard.

No excessive force must be applied to the dipole arms, because they might bend or the soldered connections near the feedpoint may be damaged.

### Additional EUT Data

|                 |                |
|-----------------|----------------|
| Manufactured by | SPEAG          |
| Manufactured on | March 11, 2011 |

## DASY5 Validation Report for Head TSL

Date: 22.07.2013

Test Laboratory: SPEAG, Zurich, Switzerland

**DUT: Dipole 1900 MHz; Type: D1900V2; Serial: D1900V2 - SN: 5d149**

Communication System: UID 0 - CW ; Frequency: 1900 MHz

Medium parameters used:  $f = 1900$  MHz;  $\sigma = 1.36$  S/m;  $\epsilon_r = 38.9$ ;  $\rho = 1000$  kg/m<sup>3</sup>

Phantom section: Flat Section

Measurement Standard: DASY5 (IEEE/IEC/ANSI C63.19-2007)

DASY52 Configuration:

- Probe: ES3DV3 - SN3205; ConvF(4.98, 4.98, 4.98); Calibrated: 28.12.2012;
- Sensor-Surface: 3mm (Mechanical Surface Detection)
- Electronics: DAE4 Sn601; Calibrated: 25.04.2013
- Phantom: Flat Phantom 5.0 (front); Type: QD000P50AA; Serial: 1001
- DASY52 52.8.7(1137); SEMCAD X 14.6.10(7164)

### **Dipole Calibration for Head Tissue/Pin=250 mW, d=10mm/Zoom Scan (7x7x7)/Cube 0:**

Measurement grid: dx=5mm, dy=5mm, dz=5mm

Reference Value = 96.173 V/m; Power Drift = 0.04 dB

Peak SAR (extrapolated) = 18.0 W/kg

**SAR(1 g) = 9.99 W/kg; SAR(10 g) = 5.28 W/kg**

Maximum value of SAR (measured) = 12.4 W/kg

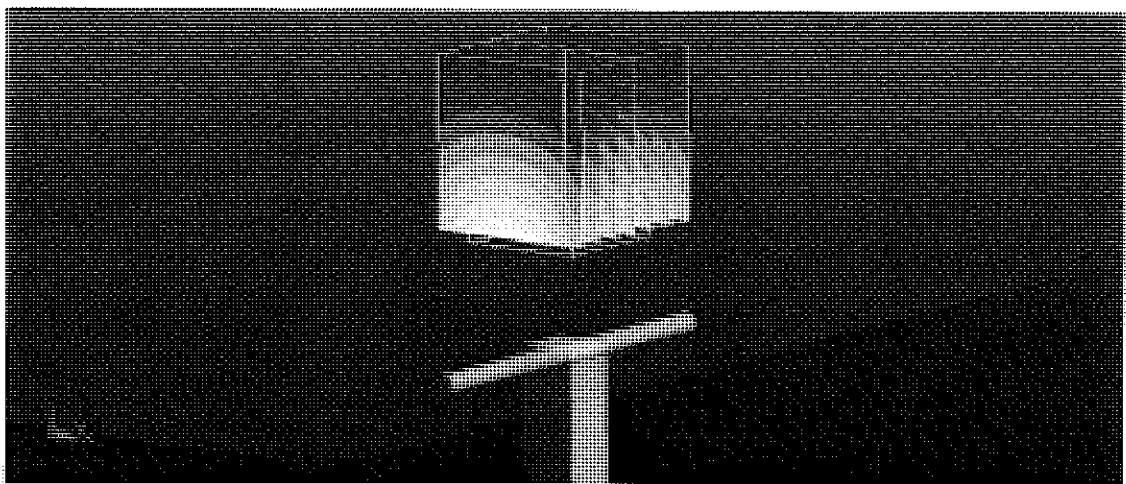
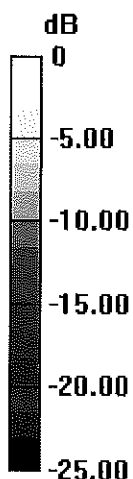

0 dB = 12.4 W/kg = 10.93 dBW/kg

# Impedance Measurement Plot for Head TSL

22 Jul 2013 11:59:34

CH1 S11 1 U FS 1: 52.941  $\Omega$  6.0059  $\Omega$  503.09  $\rho H$  1 900.000 000 MHz

\*  
De1  
CA  
Avg  
16  
H1d

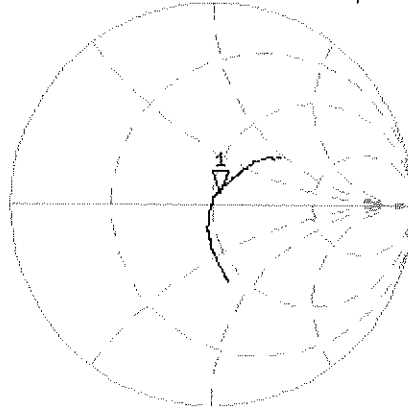

CH2 S11 LOG 5 dB/REF -20 dB 1:-23.758 dB 1 900.000 000 MHz

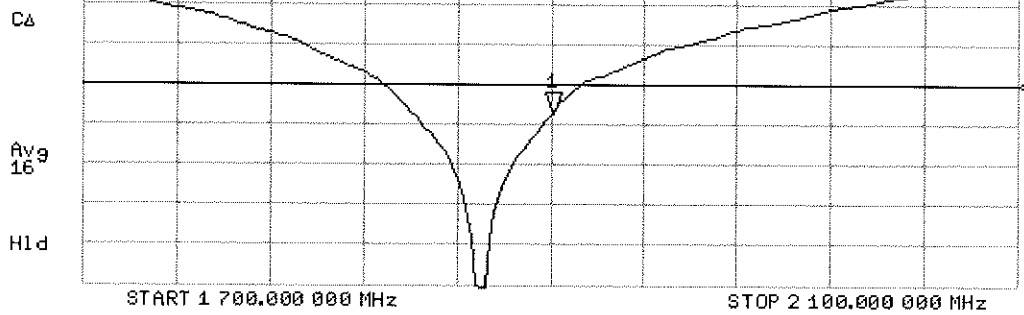

# DASY5 Validation Report for Body TSL

Date: 22.07.2013

Test Laboratory: SPEAG, Zurich, Switzerland

**DUT: Dipole 1900 MHz; Type: D1900V2; Serial: D1900V2 - SN: 5d149**

Communication System: UID 0 - CW ; Frequency: 1900 MHz

Medium parameters used:  $f = 1900$  MHz;  $\sigma = 1.49$  S/m;  $\epsilon_r = 53.4$ ;  $\rho = 1000$  kg/m<sup>3</sup>

Phantom section: Flat Section

Measurement Standard: DASY5 (IEEE/IEC/ANSI C63.19-2007)

DASY52 Configuration:

- Probe: ES3DV3 - SN3205; ConvF(4.6, 4.6, 4.6); Calibrated: 28.12.2012;
- Sensor-Surface: 3mm (Mechanical Surface Detection)
- Electronics: DAE4 Sn601; Calibrated: 25.04.2013
- Phantom: Flat Phantom 5.0 (back); Type: QD000P50AA; Serial: 1002
- DASY52 52.8.7(1137); SEMCAD X 14.6.10(7164)

## Dipole Calibration for Body Tissue/Pin=250 mW, d=10mm/Zoom Scan (7x7x7)/Cube 0:

Measurement grid: dx=5mm, dy=5mm, dz=5mm

Reference Value = 96.173 V/m; Power Drift = 0.01 dB

Peak SAR (extrapolated) = 17.0 W/kg

**SAR(1 g) = 10 W/kg; SAR(10 g) = 5.36 W/kg**

Maximum value of SAR (measured) = 12.6 W/kg

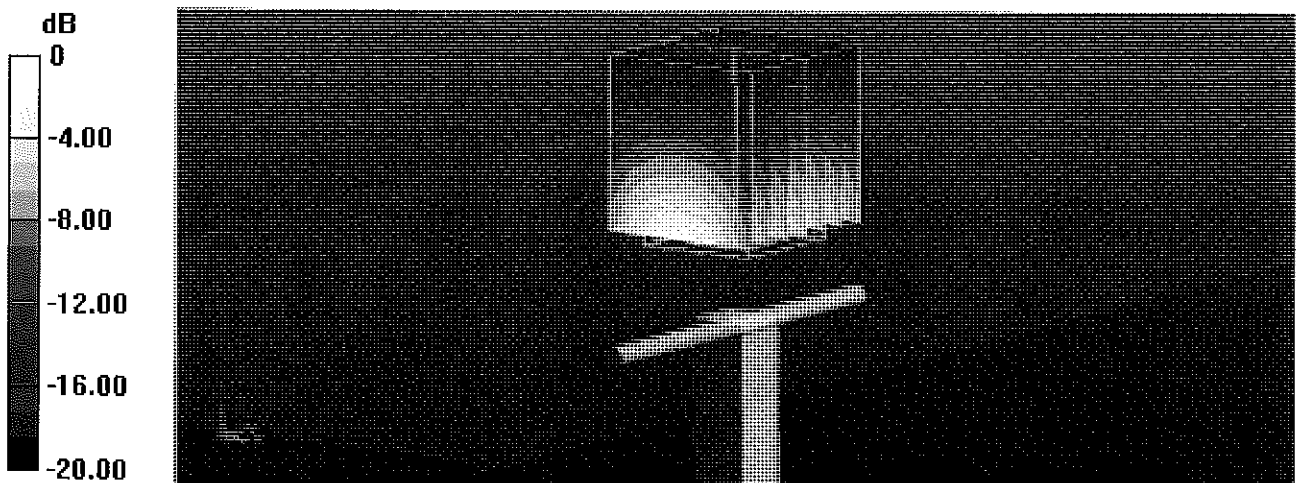

0 dB = 12.6 W/kg = 11.00 dBW/kg

# Impedance Measurement Plot for Body TSL

22 Jul 2013 11:32:14

CH1 S11 1 U FS 1: 48.525  $\Omega$  6.3906  $\mu$  535.32 pF 1 900.000 000 MHz

\*  
De1  
CA

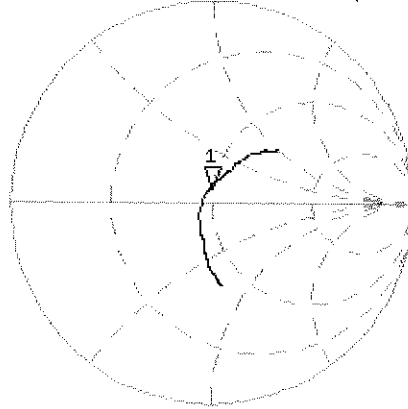

Avg  
16

H1d

CH2 S11 LOG 5 dB/REF -20 dB 1:-23.547 dB 1 900.000 000 MHz

CA

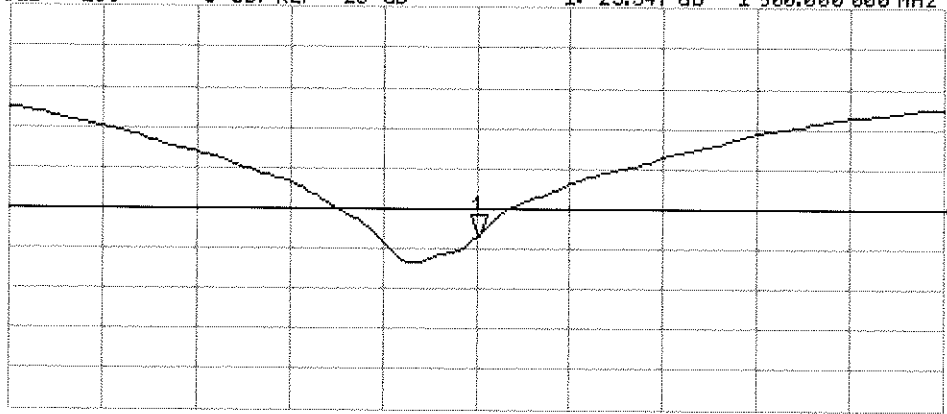

START 1 700.000 000 MHz

STOP 2 100.000 000 MHz



Accredited by the Swiss Accreditation Service (SAS)  
The Swiss Accreditation Service is one of the signatories to the EA  
Multilateral Agreement for the recognition of calibration certificates

Accreditation No.: **SCS 108**

Client **PC Test**

Certificate No: **ES3-3319\_Apr13**

## CALIBRATION CERTIFICATE

Object **ES3DV3 - SN:3319**

Calibration procedure(s) **QA CAL-01.v8, QA CAL-23.v4, QA CAL-25.v4  
Calibration procedure for dosimetric E-field probes**

Calibration date: **April 29, 2013**

VCC  
6/14/13

This calibration certificate documents the traceability to national standards, which realize the physical units of measurements (SI).  
The measurements and the uncertainties with confidence probability are given on the following pages and are part of the certificate.

All calibrations have been conducted in the closed laboratory facility: environment temperature (22 ± 3)°C and humidity < 70%.

Calibration Equipment used (M&TE critical for calibration)

| Primary Standards          | ID              | Cal Date (Certificate No.)        | Scheduled Calibration  |
|----------------------------|-----------------|-----------------------------------|------------------------|
| Power meter E4419B         | GB41293874      | 04-Apr-13 (No. 217-01733)         | Apr-14                 |
| Power sensor E4412A        | MY41498087      | 04-Apr-13 (No. 217-01733)         | Apr-14                 |
| Reference 3 dB Attenuator  | SN: S5054 (3c)  | 04-Apr-13 (No. 217-01737)         | Apr-14                 |
| Reference 20 dB Attenuator | SN: S5277 (20x) | 04-Apr-13 (No. 217-01735)         | Apr-14                 |
| Reference 30 dB Attenuator | SN: S5129 (30b) | 04-Apr-13 (No. 217-01738)         | Apr-14                 |
| Reference Probe ES3DV2     | SN: 3013        | 28-Dec-12 (No. ES3-3013_Dec12)    | Dec-13                 |
| DAE4                       | SN: 660         | 31-Jan-13 (No. DAE4-660_Jan13)    | Jan-14                 |
| Secondary Standards        | ID              | Check Date (in house)             | Scheduled Check        |
| RF generator HP 8648C      | US3642U01700    | 4-Aug-99 (in house check Apr-13)  | In house check: Apr-15 |
| Network Analyzer HP 8753E  | US37390585      | 18-Oct-01 (in house check Oct-12) | In house check: Oct-13 |

|                | Name          | Function              | Signature              |
|----------------|---------------|-----------------------|------------------------|
| Calibrated by: | Dimce Iliev   | Laboratory Technician |                        |
| Approved by:   | Katja Pokovic | Technical Manager     |                        |
|                |               |                       | Issued: April 29, 2013 |

This calibration certificate shall not be reproduced except in full without written approval of the laboratory.



Accredited by the Swiss Accreditation Service (SAS)

Accreditation No.: **SCS 108**

The Swiss Accreditation Service is one of the signatories to the EA  
Multilateral Agreement for the recognition of calibration certificates

### Glossary:

|                          |   |
|--------------------------|---|
| TSL                      | tissue simulating liquid  |
| NORM <sub>x,y,z</sub>    | sensitivity in free space   |
| ConvF                    | sensitivity in TSL / NORM <sub>x,y,z</sub>  |
| DCP                      | diode compression point   |
| CF                       | crest factor (1/duty_cycle) of the RF signal  |
| A, B, C, D               | modulation dependent linearization parameters   |
| Polarization $\varphi$   | $\varphi$ rotation around probe axis  |
| Polarization $\vartheta$ | $\vartheta$ rotation around an axis that is in the plane normal to probe axis (at measurement center),<br>i.e., $\vartheta = 0$ is normal to probe axis |

### Calibration is Performed According to the Following Standards:

- IEEE Std 1528-2003, "IEEE Recommended Practice for Determining the Peak Spatial-Averaged Specific Absorption Rate (SAR) in the Human Head from Wireless Communications Devices: Measurement Techniques", December 2003
- IEC 62209-1, "Procedure to measure the Specific Absorption Rate (SAR) for hand-held devices used in close proximity to the ear (frequency range of 300 MHz to 3 GHz)", February 2005

### Methods Applied and Interpretation of Parameters:

- NORM<sub>x,y,z</sub>**: Assessed for E-field polarization  $\vartheta = 0$  ( $f \leq 900$  MHz in TEM-cell;  $f > 1800$  MHz: R22 waveguide). NORM<sub>x,y,z</sub> are only intermediate values, i.e., the uncertainties of NORM<sub>x,y,z</sub> does not affect the E<sup>2</sup>-field uncertainty inside TSL (see below ConvF).
- NORM(f)<sub>x,y,z</sub>** = NORM<sub>x,y,z</sub> \* frequency\_response (see Frequency Response Chart). This linearization is implemented in DASY4 software versions later than 4.2. The uncertainty of the frequency response is included in the stated uncertainty of ConvF.
- DCP<sub>x,y,z</sub>**: DCP are numerical linearization parameters assessed based on the data of power sweep with CW signal (no uncertainty required). DCP does not depend on frequency nor media.
- PAR**: PAR is the Peak to Average Ratio that is not calibrated but determined based on the signal characteristics
- A<sub>x,y,z</sub>; B<sub>x,y,z</sub>; C<sub>x,y,z</sub>; D<sub>x,y,z</sub>; VR<sub>x,y,z</sub>; A, B, C, D** are numerical linearization parameters assessed based on the data of power sweep for specific modulation signal. The parameters do not depend on frequency nor media. VR is the maximum calibration range expressed in RMS voltage across the diode.
- ConvF and Boundary Effect Parameters**: Assessed in flat phantom using E-field (or Temperature Transfer Standard for  $f \leq 800$  MHz) and inside waveguide using analytical field distributions based on power measurements for  $f > 800$  MHz. The same setups are used for assessment of the parameters applied for boundary compensation (alpha, depth) of which typical uncertainty values are given. These parameters are used in DASY4 software to improve probe accuracy close to the boundary. The sensitivity in TSL corresponds to NORM<sub>x,y,z</sub> \* ConvF whereby the uncertainty corresponds to that given for ConvF. A frequency dependent ConvF is used in DASY version 4.4 and higher which allows extending the validity from  $\pm 50$  MHz to  $\pm 100$  MHz.
- Spherical isotropy (3D deviation from isotropy)**: in a field of low gradients realized using a flat phantom exposed by a patch antenna.
- Sensor Offset**: The sensor offset corresponds to the offset of virtual measurement center from the probe tip (on probe axis). No tolerance required.

# Probe ES3DV3

## SN:3319

Manufactured: January 10, 2012  
Calibrated: April 29, 2013

Calibrated for DASY/EASY Systems  
(Note: non-compatible with DASY2 system!)

## DASY/EASY - Parameters of Probe: ES3DV3 - SN:3319

### Basic Calibration Parameters

|   | Sensor X | Sensor Y | Sensor Z | Unc (k=2)     |
|---|----------|----------|----------|---------------|
| Norm ( $\mu\text{V}/(\text{V}/\text{m})^2$ ) <sup>A</sup> | 1.12     | 1.20     | 1.22     | $\pm 10.1 \%$ |
| DCP (mV) <sup>B</sup>                                     | 100.7    | 102.6    | 102.4    |               |

### Modulation Calibration Parameters

| UID | Communication System Name |   | A<br>dB | B<br>dB $\sqrt{\mu\text{V}}$ | C   | D<br>dB | VR<br>mV | Unc <sup>E</sup><br>(k=2) |
|-----|---------------------------|---|---------|------------------------------|-----|---------|----------|---------------------------|
| 0   | CW                        | X | 0.0     | 0.0                          | 1.0 | 0.00    | 152.0    | $\pm 3.8 \%$              |
|     |                           | Y | 0.0     | 0.0                          | 1.0 |         | 159.0    |                           |
|     |                           | Z | 0.0     | 0.0                          | 1.0 |         | 149.8    |                           |

The reported uncertainty of measurement is stated as the standard uncertainty of measurement multiplied by the coverage factor  $k=2$ , which for a normal distribution corresponds to a coverage probability of approximately 95%.

<sup>A</sup> The uncertainties of NormX,Y,Z do not affect the  $E^2$ -field uncertainty inside TSL (see Pages 5 and 6).

<sup>B</sup> Numerical linearization parameter: uncertainty not required.

<sup>E</sup> Uncertainty is determined using the max. deviation from linear response applying rectangular distribution and is expressed for the square of the field value.

## DASY/EASY - Parameters of Probe: ES3DV3 - SN:3319

### Calibration Parameter Determined in Head Tissue Simulating Media

| f (MHz) <sup>C</sup> | Relative Permittivity <sup>F</sup> | Conductivity (S/m) <sup>F</sup> | ConvF X | ConvF Y | ConvF Z | Alpha | Depth (mm) | Unct. (k=2) |
|----------------------|------------------------------------|---------------------------------|---------|---------|---------|-------|------------|-------------|
| 750                  | 41.9                               | 0.89                            | 6.49    | 6.49    | 6.49    | 0.28  | 1.97       | ± 12.0 %    |
| 850                  | 41.5                               | 0.92                            | 6.23    | 6.23    | 6.23    | 0.42  | 1.57       | ± 12.0 %    |
| 1900                 | 40.0                               | 1.40                            | 5.22    | 5.22    | 5.22    | 0.80  | 1.24       | ± 12.0 %    |
| 2450                 | 39.2                               | 1.80                            | 4.57    | 4.57    | 4.57    | 0.80  | 1.32       | ± 12.0 %    |

<sup>C</sup> Frequency validity of ± 100 MHz only applies for DASY v4.4 and higher (see Page 2), else it is restricted to ± 50 MHz. The uncertainty is the RSS of the ConvF uncertainty at calibration frequency and the uncertainty for the indicated frequency band.

<sup>F</sup> At frequencies below 3 GHz, the validity of tissue parameters ( $\epsilon$  and  $\sigma$ ) can be relaxed to ± 10% if liquid compensation formula is applied to measured SAR values. At frequencies above 3 GHz, the validity of tissue parameters ( $\epsilon$  and  $\sigma$ ) is restricted to ± 5%. The uncertainty is the RSS of the ConvF uncertainty for indicated target tissue parameters.

## DASY/EASY - Parameters of Probe: ES3DV3 - SN:3319

### Calibration Parameter Determined in Body Tissue Simulating Media

| f (MHz) <sup>C</sup> | Relative Permittivity <sup>F</sup> | Conductivity (S/m) <sup>F</sup> | ConvF X | ConvF Y | ConvF Z | Alpha | Depth (mm) | Unct. (k=2) |
|----------------------|------------------------------------|---------------------------------|---------|---------|---------|-------|------------|-------------|
| 750                  | 55.5                               | 0.96                            | 6.30    | 6.30    | 6.30    | 0.45  | 1.53       | ± 12.0 %    |
| 850                  | 55.2                               | 0.99                            | 6.15    | 6.15    | 6.15    | 0.42  | 1.65       | ± 12.0 %    |
| 1900                 | 53.3                               | 1.52                            | 4.85    | 4.85    | 4.85    | 0.63  | 1.49       | ± 12.0 %    |
| 2450                 | 52.7                               | 1.95                            | 4.32    | 4.32    | 4.32    | 0.69  | 1.20       | ± 12.0 %    |

<sup>C</sup> Frequency validity of ± 100 MHz only applies for DASY v4.4 and higher (see Page 2), else it is restricted to ± 50 MHz. The uncertainty is the RSS of the ConvF uncertainty at calibration frequency and the uncertainty for the indicated frequency band.

<sup>F</sup> At frequencies below 3 GHz, the validity of tissue parameters ( $\epsilon$  and  $\sigma$ ) can be relaxed to ± 10% if liquid compensation formula is applied to measured SAR values. At frequencies above 3 GHz, the validity of tissue parameters ( $\epsilon$  and  $\sigma$ ) is restricted to ± 5%. The uncertainty is the RSS of the ConvF uncertainty for indicated target tissue parameters.

### Frequency Response of E-Field (TEM-Cell:ifi110 EXX, Waveguide: R22)

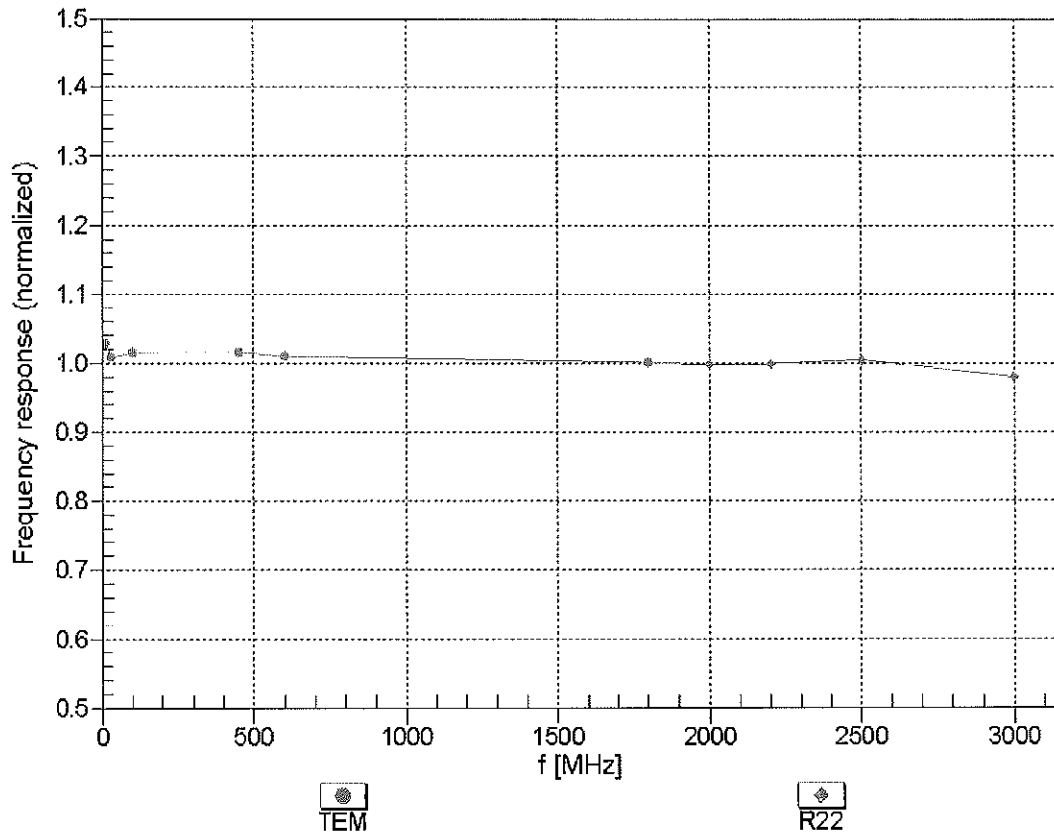

Uncertainty of Frequency Response of E-field:  $\pm 6.3\%$  (k=2)

### Receiving Pattern ( $\phi$ ), $\theta = 0^\circ$

f=600 MHz,TEM

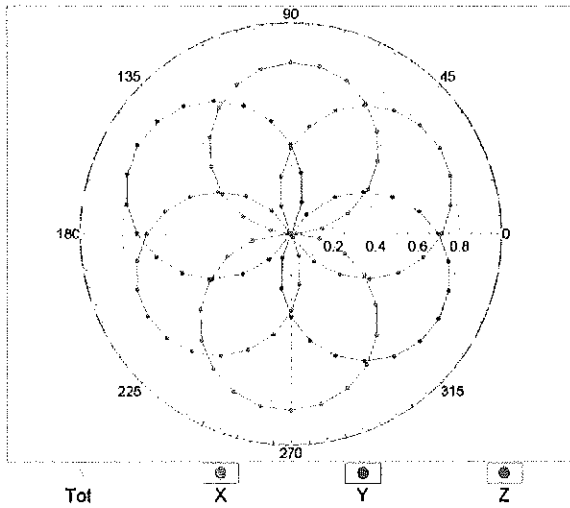

f=1800 MHz,R22

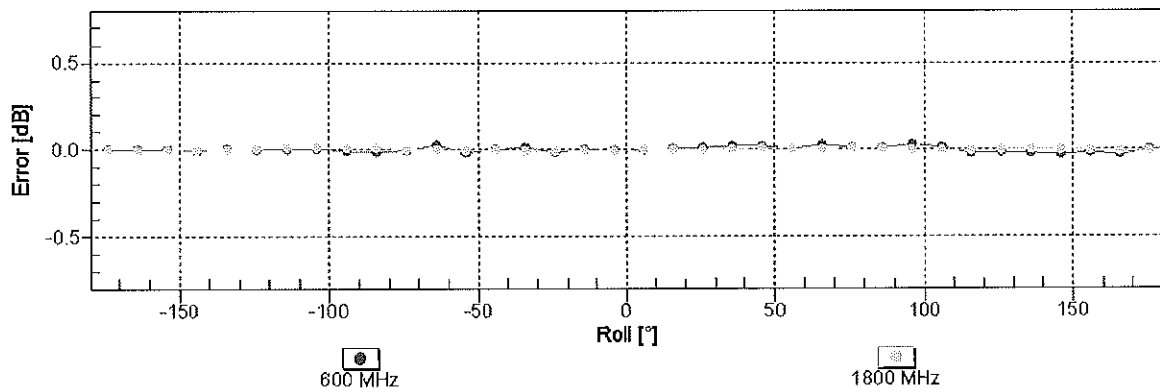
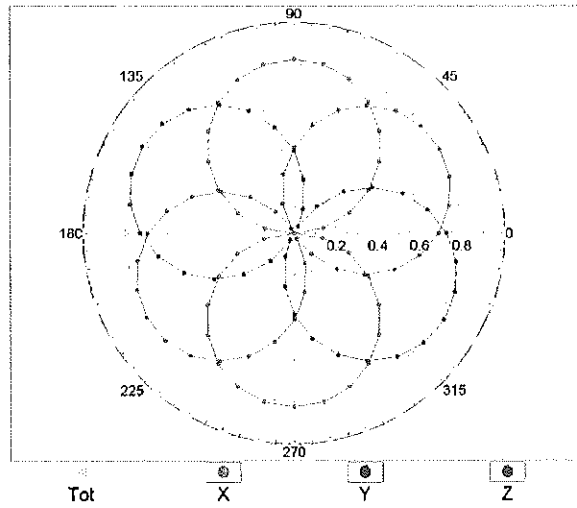

Uncertainty of Axial Isotropy Assessment:  $\pm 0.5\%$  (k=2)

### Dynamic Range $f(\text{SAR}_{\text{head}})$ (TEM cell , $f = 900 \text{ MHz}$ )

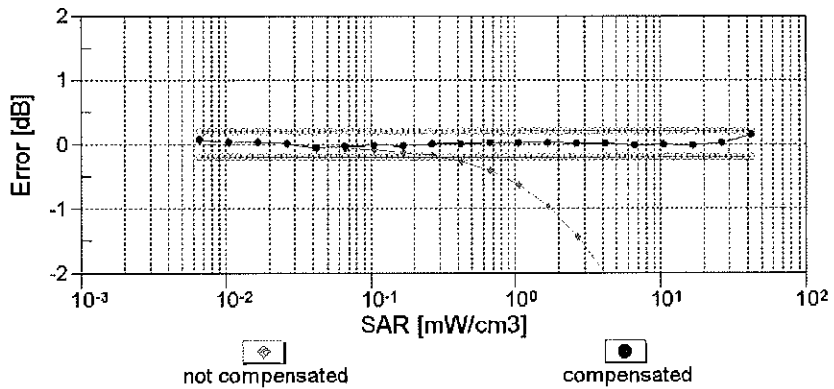
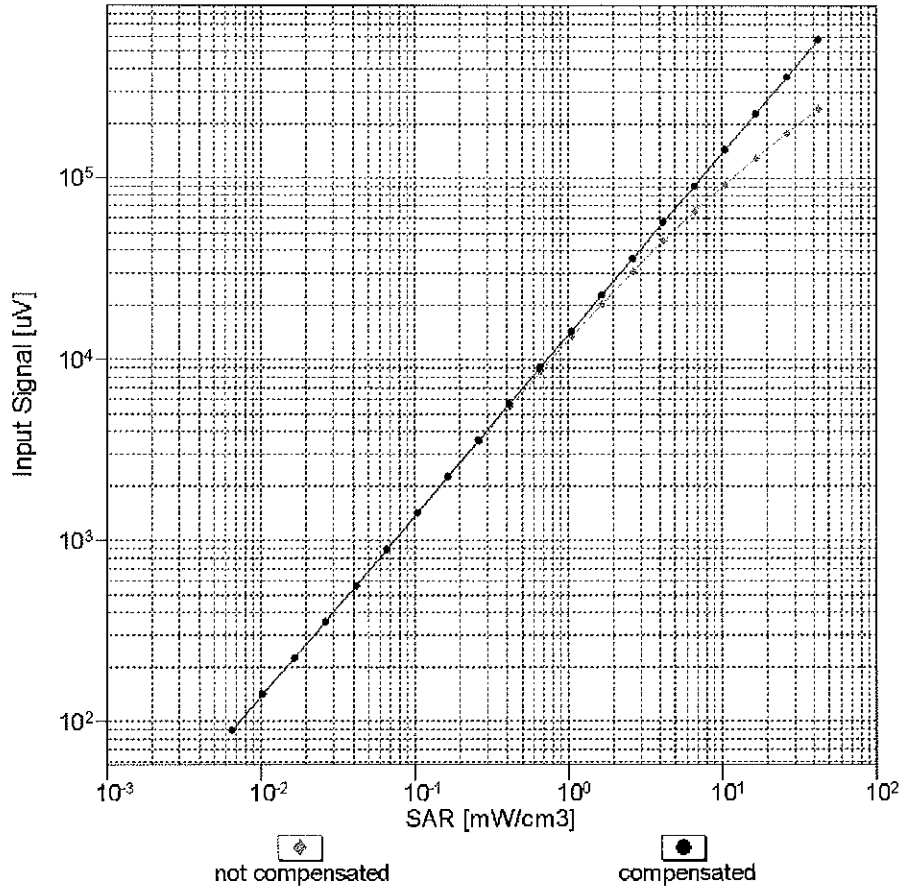

Uncertainty of Linearity Assessment:  $\pm 0.6\%$  ( $k=2$ )

# Conversion Factor Assessment

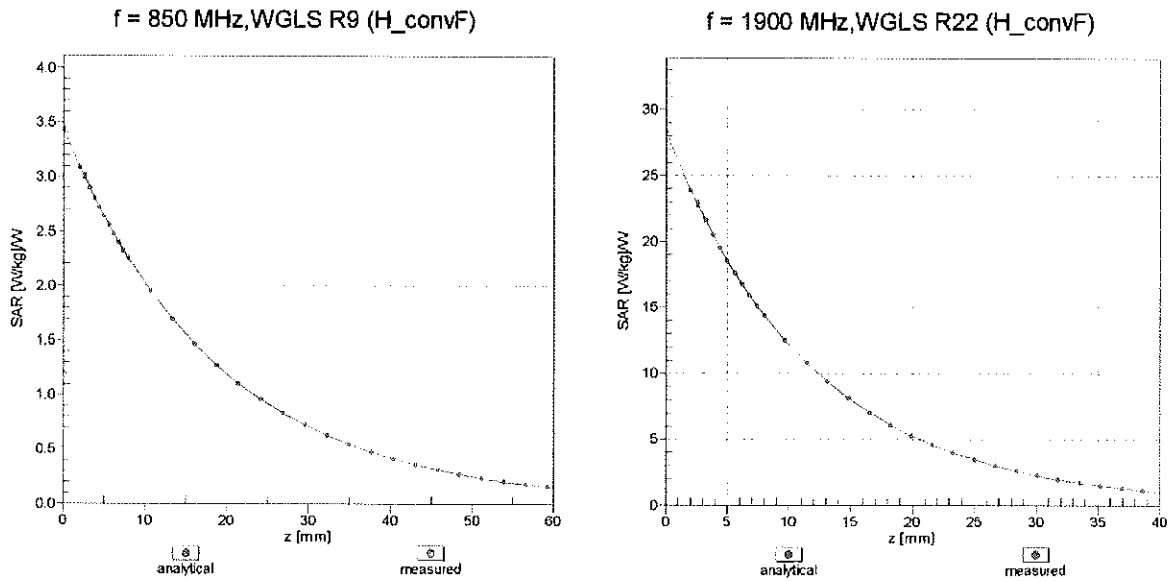

## Deviation from Isotropy in Liquid Error ( $\phi, \theta$ ), f = 900 MHz

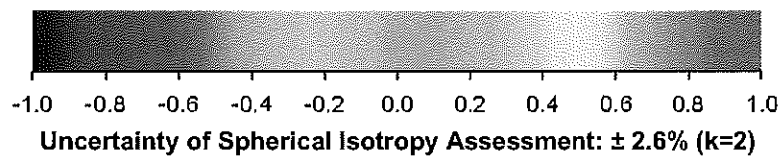
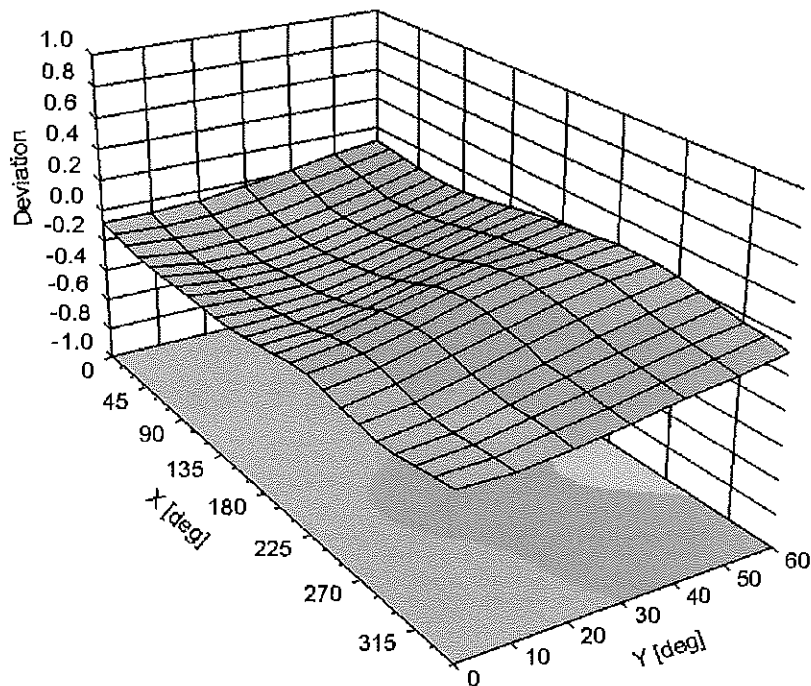

## DASY/EASY - Parameters of Probe: ES3DV3 - SN:3319

### Other Probe Parameters

|   |            |
|---|------------|
| Sensor Arrangement                            | Triangular |
| Connector Angle (°)                           | -104.1     |
| Mechanical Surface Detection Mode             | enabled    |
| Optical Surface Detection Mode                | disabled   |
| Probe Overall Length                          | 337 mm     |
| Probe Body Diameter                           | 10 mm      |
| Tip Length                                    | 10 mm      |
| Tip Diameter                                  | 4 mm       |
| Probe Tip to Sensor X Calibration Point       | 2 mm       |
| Probe Tip to Sensor Y Calibration Point       | 2 mm       |
| Probe Tip to Sensor Z Calibration Point       | 2 mm       |
| Recommended Measurement Distance from Surface | 3 mm       |

## Additional Conversion Factors for Dosimetric E-Field Probe

|                         |                       |
|-------------------------|-----------------------|
| Type:                   | <b>ES3DV3</b>         |
| Serial Number:          | <b>3319</b>           |
| Place of Assessment:    | <b>Zurich</b>         |
| Date of Assessment:     | <b>June 19, 2013</b>  |
| Probe Calibration Date: | <b>April 29, 2013</b> |

Schmid & Partner Engineering AG hereby certifies that conversion factor(s) of this probe have been evaluated on the date indicated above. The assessment was performed using the FDTD numerical code SEMCAD of Schmid & Partner Engineering AG. The evaluation is coupled with measured conversion factors (probe calibration date indicated above). The uncertainty of the numerical assessment is based on the extrapolation from measured value at 835 MHz or at 1900 MHz.

Assessed by:

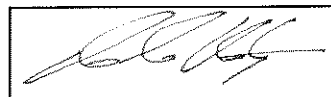

✓  
KOK  
6/25/13

**Dosimetric E-Field Probe ES3DV3 SN:3319**Conversion factor ( $\pm$  standard deviation)1750  $\pm$  50 MHz      *ConvF*      5.59  $\pm$  7% $\epsilon_r = 40.1 \pm 5\%$   
 $\sigma = 1.37 \pm 5\%$  mho/m  
(head tissue)1750  $\pm$  50 MHz      *ConvF*      5.22  $\pm$  7% $\epsilon_r = 53.4 \pm 5\%$   
 $\sigma = 1.49 \pm 5\%$  mho/m  
(body tissue)**Important Note:**

For numerically assessed probe conversion factors, parameters Alpha and Delta in the DASY software must have the following entries: Alpha = 0 and Delta = 1.

Please see also DASY Manual.



Accredited by the Swiss Accreditation Service (SAS)  
The Swiss Accreditation Service is one of the signatories to the EA  
Multilateral Agreement for the recognition of calibration certificates

Accreditation No.: **SCS 108**

Client **PC Test**

Certificate No: **D2450V2-719\_Aug13**

## CALIBRATION CERTIFICATE

Object **D2450V2 - SN: 719**

Calibration procedure(s) **QA CAL-05.v9  
Calibration procedure for dipole validation kits above 700 MHz**

Calibration date: **August 23, 2013**

*✓cc  
9/13/13*

This calibration certificate documents the traceability to national standards, which realize the physical units of measurements (SI).  
The measurements and the uncertainties with confidence probability are given on the following pages and are part of the certificate.

All calibrations have been conducted in the closed laboratory facility: environment temperature (22 ± 3)°C and humidity < 70%.

Calibration Equipment used (M&TE critical for calibration)

| Primary Standards           | ID #               | Cal Date (Certificate No.)        | Scheduled Calibration  |
|-----------------------------|--------------------|-----------------------------------|------------------------|
| Power meter EPM-442A        | GB37480704         | 01-Nov-12 (No. 217-01640)         | Oct-13                 |
| Power sensor HP 8481A       | US37292783         | 01-Nov-12 (No. 217-01640)         | Oct-13                 |
| Reference 20 dB Attenuator  | SN: 5058 (20k)     | 04-Apr-13 (No. 217-01736)         | Apr-14                 |
| Type-N mismatch combination | SN: 5047.3 / 06327 | 04-Apr-13 (No. 217-01739)         | Apr-14                 |
| Reference Probe ES3DV3      | SN: 3205           | 28-Dec-12 (No. ES3-3205_Dec12)    | Dec-13                 |
| DAE4                        | SN: 601            | 25-Apr-13 (No. DAE4-601_Apr13)    | Apr-14                 |
| Secondary Standards         | ID #               | Check Date (in house)             | Scheduled Check        |
| Power sensor HP 8481A       | MY41092317         | 18-Oct-02 (in house check Oct-11) | In house check: Oct-13 |
| RF generator R&S SMT-06     | 100005             | 04-Aug-99 (in house check Oct-11) | In house check: Oct-13 |
| Network Analyzer HP 8753E   | US37390585 S4206   | 18-Oct-01 (in house check Oct-12) | In house check: Oct-13 |

|                |                               |                                   |               |
|----------------|-------------------------------|-----------------------------------|---------------|
| Calibrated by: | Name<br><b>Jeton Kastrati</b> | Function<br>Laboratory Technician | Signature<br> |
| Approved by:   | Name<br><b>Katja Pokovic</b>  | Function<br>Technical Manager     | Signature<br> |

Issued: August 23, 2013

This calibration certificate shall not be reproduced except in full without written approval of the laboratory.



Accredited by the Swiss Accreditation Service (SAS)

The Swiss Accreditation Service is one of the signatories to the EA  
Multilateral Agreement for the recognition of calibration certificates

Accreditation No.: **SCS 108**

### Glossary:

|       |                                 |
|-------|---------------------------------|
| TSL   | tissue simulating liquid        |
| ConvF | sensitivity in TSL / NORM x,y,z |
| N/A   | not applicable or not measured  |

### Calibration is Performed According to the Following Standards:

- IEEE Std 1528-2003, "IEEE Recommended Practice for Determining the Peak Spatial-Averaged Specific Absorption Rate (SAR) in the Human Head from Wireless Communications Devices: Measurement Techniques", December 2003
- IEC 62209-1, "Procedure to measure the Specific Absorption Rate (SAR) for hand-held devices used in close proximity to the ear (frequency range of 300 MHz to 3 GHz)", February 2005
- KDB 865664, "SAR Measurement Requirements for 100 MHz to 6 GHz"

### Additional Documentation:

- DASY4/5 System Handbook

### Methods Applied and Interpretation of Parameters:

- Measurement Conditions:* Further details are available from the Validation Report at the end of the certificate. All figures stated in the certificate are valid at the frequency indicated.
- Antenna Parameters with TSL:* The dipole is mounted with the spacer to position its feed point exactly below the center marking of the flat phantom section, with the arms oriented parallel to the body axis.
- Feed Point Impedance and Return Loss:* These parameters are measured with the dipole positioned under the liquid filled phantom. The impedance stated is transformed from the measurement at the SMA connector to the feed point. The Return Loss ensures low reflected power. No uncertainty required.
- Electrical Delay:* One-way delay between the SMA connector and the antenna feed point. No uncertainty required.
- SAR measured:* SAR measured at the stated antenna input power.
- SAR normalized:* SAR as measured, normalized to an input power of 1 W at the antenna connector.
- SAR for nominal TSL parameters:* The measured TSL parameters are used to calculate the nominal SAR result.

The reported uncertainty of measurement is stated as the standard uncertainty of measurement multiplied by the coverage factor  $k=2$ , which for a normal distribution corresponds to a coverage probability of approximately 95%.

## Measurement Conditions

DASY system configuration, as far as not given on page 1.

|                                     |                        |             |
|-------------------------------------|------------------------|-------------|
| <b>DASY Version</b>                 | DASY5                  | V52.8.7     |
| <b>Extrapolation</b>                | Advanced Extrapolation |             |
| <b>Phantom</b>                      | Modular Flat Phantom   |             |
| <b>Distance Dipole Center - TSL</b> | 10 mm                  | with Spacer |
| <b>Zoom Scan Resolution</b>         | dx, dy, dz = 5 mm      |             |
| <b>Frequency</b>                    | 2450 MHz $\pm$ 1 MHz   |             |

## Head TSL parameters

The following parameters and calculations were applied.

|  | Temperature         | Permittivity   | Conductivity         |
|--|---------------------|----------------|----------------------|
| <b>Nominal Head TSL parameters</b>             | 22.0 °C             | 39.2           | 1.80 mho/m           |
| <b>Measured Head TSL parameters</b>            | (22.0 $\pm$ 0.2) °C | 37.8 $\pm$ 6 % | 1.80 mho/m $\pm$ 6 % |
| <b>Head TSL temperature change during test</b> | < 0.5 °C            | ----           | ----                 |

## SAR result with Head TSL

| <b>SAR averaged over 1 cm<sup>3</sup> (1 g) of Head TSL</b> | Condition          |  |
|---|--------------------|--|
| SAR measured  | 250 mW input power | 13.4 W/kg                                      |
| SAR for nominal Head TSL parameters                         | normalized to 1W   | <b>53.2 W/kg <math>\pm</math> 17.0 % (k=2)</b> |

| <b>SAR averaged over 10 cm<sup>3</sup> (10 g) of Head TSL</b> | condition          |  |
|---|--------------------|--|
| SAR measured  | 250 mW input power | 6.23 W/kg                                      |
| SAR for nominal Head TSL parameters                           | normalized to 1W   | <b>24.8 W/kg <math>\pm</math> 16.5 % (k=2)</b> |

## Body TSL parameters

The following parameters and calculations were applied.

|  | Temperature         | Permittivity   | Conductivity         |
|--|---------------------|----------------|----------------------|
| <b>Nominal Body TSL parameters</b>             | 22.0 °C             | 52.7           | 1.95 mho/m           |
| <b>Measured Body TSL parameters</b>            | (22.0 $\pm$ 0.2) °C | 50.6 $\pm$ 6 % | 2.03 mho/m $\pm$ 6 % |
| <b>Body TSL temperature change during test</b> | < 0.5 °C            | ----           | ----                 |

## SAR result with Body TSL

| <b>SAR averaged over 1 cm<sup>3</sup> (1 g) of Body TSL</b> | Condition          |  |
|---|--------------------|--|
| SAR measured  | 250 mW input power | 13.3 W/kg                                      |
| SAR for nominal Body TSL parameters                         | normalized to 1W   | <b>51.7 W/kg <math>\pm</math> 17.0 % (k=2)</b> |

| <b>SAR averaged over 10 cm<sup>3</sup> (10 g) of Body TSL</b> | condition          |  |
|---|--------------------|--|
| SAR measured  | 250 mW input power | 6.14 W/kg                                      |
| SAR for nominal Body TSL parameters                           | normalized to 1W   | <b>24.1 W/kg <math>\pm</math> 16.5 % (k=2)</b> |

## Appendix

### Antenna Parameters with Head TSL

|                                      |                                |
|--------------------------------------|--------------------------------|
| Impedance, transformed to feed point | 54.6 $\Omega$ + 3.5 j $\Omega$ |
| Return Loss                          | - 25.1 dB                      |

### Antenna Parameters with Body TSL

|                                      |                                |
|--------------------------------------|--------------------------------|
| Impedance, transformed to feed point | 51.1 $\Omega$ + 5.4 j $\Omega$ |
| Return Loss                          | - 25.3 dB                      |

### General Antenna Parameters and Design

|                                  |          |
|----------------------------------|----------|
| Electrical Delay (one direction) | 1.149 ns |
|----------------------------------|----------|

After long term use with 100W radiated power, only a slight warming of the dipole near the feedpoint can be measured.

The dipole is made of standard semirigid coaxial cable. The center conductor of the feeding line is directly connected to the second arm of the dipole. The antenna is therefore short-circuited for DC-signals. On some of the dipoles, small end caps are added to the dipole arms in order to improve matching when loaded according to the position as explained in the "Measurement Conditions" paragraph. The SAR data are not affected by this change. The overall dipole length is still according to the Standard.

No excessive force must be applied to the dipole arms, because they might bend or the soldered connections near the feedpoint may be damaged.

### Additional EUT Data

|                 |                    |
|-----------------|--------------------|
| Manufactured by | SPEAG              |
| Manufactured on | September 10, 2002 |

## DASY5 Validation Report for Head TSL

Date: 22.08.2013

Test Laboratory: SPEAG, Zurich, Switzerland

**DUT: Dipole 2450 MHz; Type: D2450V2; Serial: D2450V2 - SN: 719**

Communication System: UID 0 - CW ; Frequency: 2450 MHz

Medium parameters used:  $f = 2450$  MHz;  $\sigma = 1.8$  S/m;  $\epsilon_r = 37.8$ ;  $\rho = 1000$  kg/m<sup>3</sup>

Phantom section: Flat Section

Measurement Standard: DASY5 (IEEE/IEC/ANSI C63.19-2007)

DASY52 Configuration:

- Probe: ES3DV3 - SN3205; ConvF(4.52, 4.52, 4.52); Calibrated: 28.12.2012;
- Sensor-Surface: 3mm (Mechanical Surface Detection)
- Electronics: DAE4 Sn601; Calibrated: 25.04.2013
- Phantom: Flat Phantom 5.0 (front); Type: QD000P50AA; Serial: 1001
- DASY52 52.8.7(1137); SEMCAD X 14.6.10(7164)

### Dipole Calibration for Head Tissue/Pin=250 mW, d=10mm/Zoom Scan (7x7x7)/Cube 0:

Measurement grid: dx=5mm, dy=5mm, dz=5mm

Reference Value = 100.7 V/m; Power Drift = 0.06 dB

Peak SAR (extrapolated) = 27.9 W/kg

**SAR(1 g) = 13.4 W/kg; SAR(10 g) = 6.23 W/kg**

Maximum value of SAR (measured) = 17.0 W/kg

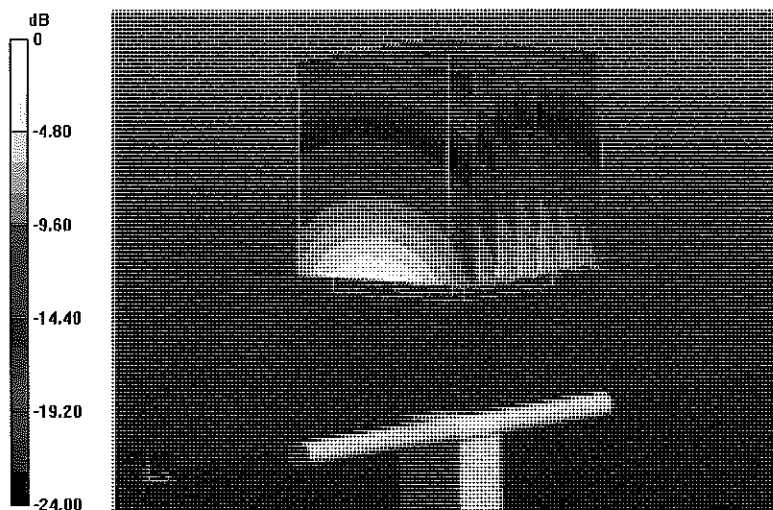

# Impedance Measurement Plot for Head TSL

22 Aug 2013 11:00:15

CH1 S11 1 U FS

4: 54.639  $\Omega$  3.5215  $\Omega$  228.76 pF

2 450.000 000 MHz

\*

De1

CA

Avg  
16

H1d

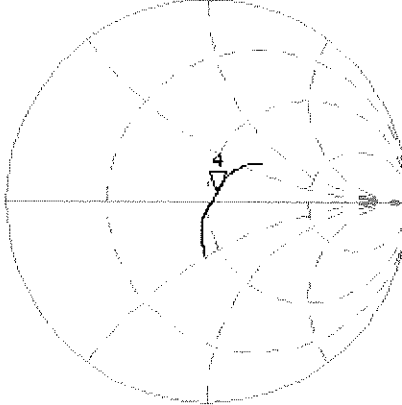

CH2 S11 LOG

5 dB/REF -20 dB

4: -25.093 dB 2 450.000 000 MHz

CA

Avg  
16

H1d

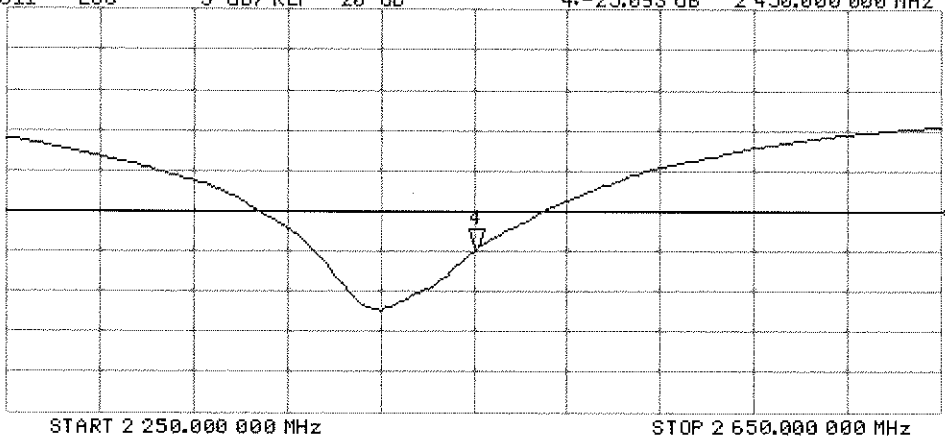

START 2 250.000 000 MHz

STOP 2 650.000 000 MHz

# DASY5 Validation Report for Body TSL

Date: 23.08.2013

Test Laboratory: SPEAG, Zurich, Switzerland

**DUT: Dipole 2450 MHz; Type: D2450V2; Serial: D2450V2 - SN: 719**

Communication System: UID 0 - CW ; Frequency: 2450 MHz

Medium parameters used:  $f = 2450$  MHz;  $\sigma = 2.03$  S/m;  $\epsilon_r = 50.6$ ;  $\rho = 1000$  kg/m<sup>3</sup>

Phantom section: Flat Section

Measurement Standard: DASY5 (IEEE/IEC/ANSI C63.19-2007)

DASY52 Configuration:

- Probe: ES3DV3 - SN3205; ConvF(4.42, 4.42, 4.42); Calibrated: 28.12.2012;
- Sensor-Surface: 3mm (Mechanical Surface Detection)
- Electronics: DAE4 Sn601; Calibrated: 25.04.2013
- Phantom: Flat Phantom 5.0 (back); Type: QD000P50AA; Serial: 1002
- DASY52 52.8.7(1137); SEMCAD X 14.6.10(7164)

## Dipole Calibration for Body Tissue/Pin=250 mW, d=10mm/Zoom Scan (7x7x7)/Cube 0:

Measurement grid: dx=5mm, dy=5mm, dz=5mm

Reference Value = 94.688 V/m; Power Drift = 0.06 dB

Peak SAR (extrapolated) = 27.9 W/kg

**SAR(1 g) = 13.3 W/kg; SAR(10 g) = 6.14 W/kg**

Maximum value of SAR (measured) = 17.2 W/kg

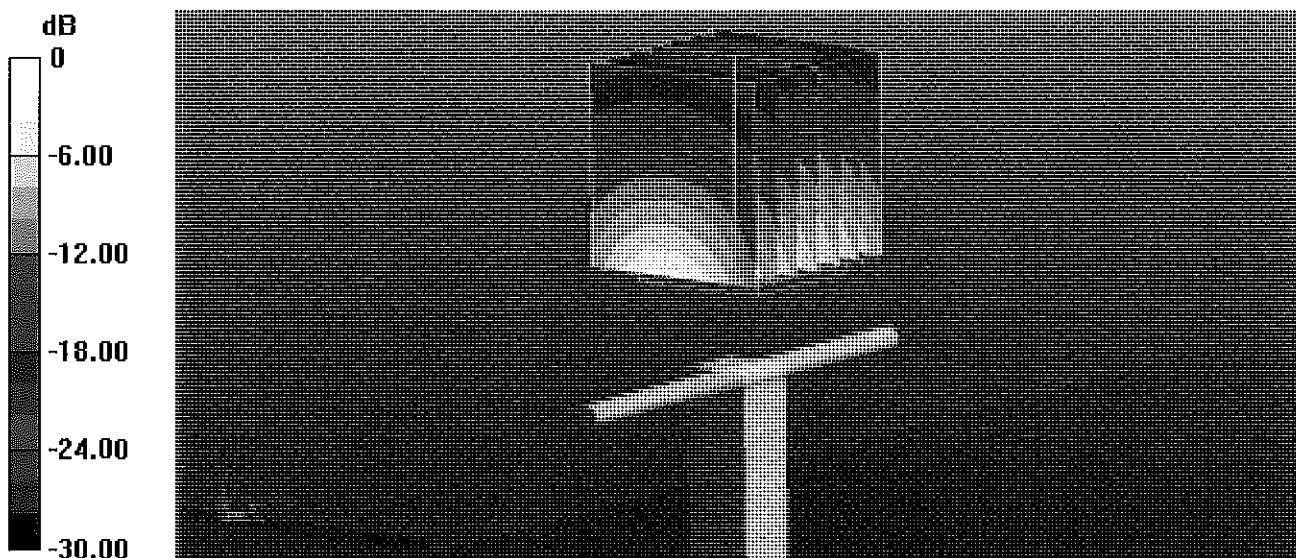

0 dB = 17.2 W/kg = 12.36 dBW/kg

# Impedance Measurement Plot for Body TSL

23 Aug 2013 09:00:38

CH1 S11 1 U FS

3: 51.135  $\Omega$  5.3965  $\Omega$  350.56  $\mu$ H

2 450.000 000 MHz

#

De1

CΔ

Avg

16

H1 d

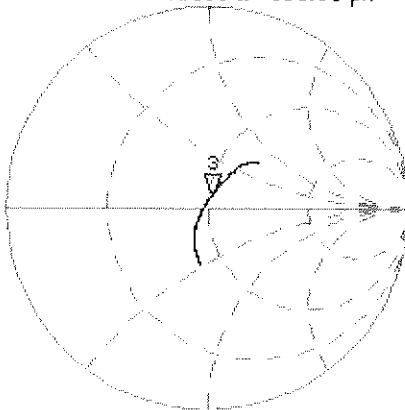

CH2 S11 LOG

5 dB/REF -20 dB

3:-25.274 dB

2 450.000 000 MHz

CΔ

Avg

16

H1 d

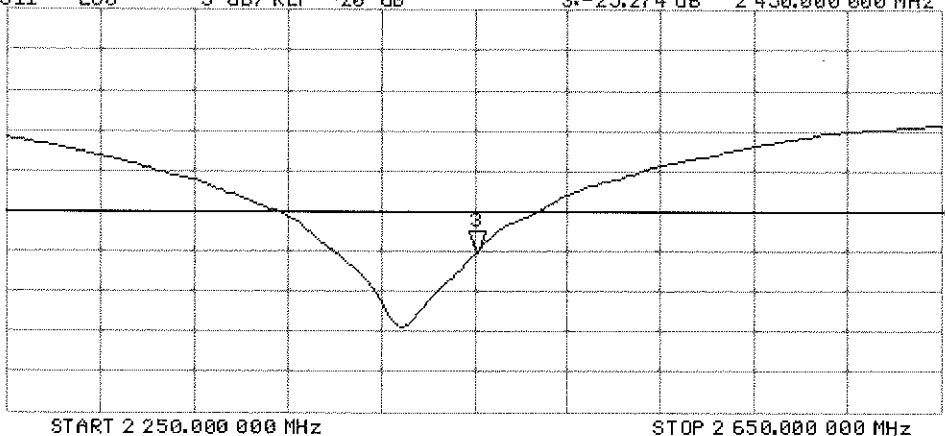

## APPENDIX D: SAR TISSUE SPECIFICATIONS

Measurement Procedure for Tissue verification:



- 5) The network analyzer and probe system was configured and calibrated.
- 6) The probe was immersed in the tissue. The tissue was placed in a nonmetallic container. Trapped air bubbles beneath the flange were minimized by placing the probe at a slight angle.
- 7) The complex admittance with respect to the probe aperture was measured
- 8) The complex relative permittivity  $\epsilon$  can be calculated from the below equation (Pournaropoulos and Misra):

$$Y = \frac{j2\omega\epsilon_r\epsilon_0}{[\ln(b/a)]^2} \int_a^b \int_a^b \int_0^\pi \cos\phi' \frac{\exp[-j\omega r(\mu_0\epsilon_r'\epsilon_0)^{1/2}]}{r} d\phi' d\rho' d\rho$$

where  $Y$  is the admittance of the probe in contact with the sample, the primed and unprimed coordinates refer to source and observation points, respectively,  $r^2 = \rho^2 + \rho'^2 - 2\rho\rho' \cos\phi'$ ,  $\omega$  is the angular frequency, and  $j = \sqrt{-1}$ .

**Table D-I  
Composition of the Tissue Equivalent Matter**

| Frequency (MHz)           | 835   | 835   | 1900  | 1900  | 2450       | 2450 | 5200-5800  | 5200-5800 |
|---------------------------|-------|-------|-------|-------|------------|------|------------|-----------|
| Tissue                    | Head  | Body  | Head  | Body  | Head       | Body | Head       | Body      |
| Ingredients (% by weight) |       |       |       |       |            |      |            |           |
| Bactericide               | 0.1   | 0.1   |       |       | See Page 2 |      | See Page 3 |           |
| DGBE                      |       |       | 44.92 | 29.44 |            | 26.7 |            |           |
| HEC                       | 1     | 1     |       |       |            |      |            |           |
| NaCl                      | 1.45  | 0.94  | 0.18  | 0.39  |            | 0.1  |            |           |
| Sucrose                   | 57    | 44.9  |       |       |            |      |            |           |
| Polysorbate (Tween) 80    |       |       |       |       |            |      |            | 20        |
| Water                     | 40.45 | 53.06 | 54.9  | 70.17 |            | 73.2 |            | 80        |

|  |   |                       |   |                                 |
|--|---|-----------------------|---|---------------------------------|
| FCC ID: A3LSMT331                      |  | SAR EVALUATION REPORT |  | Reviewed by:<br>Quality Manager |
| Test Dates:<br>01/06/2014 – 01/24/2014 | DUT Type:<br>Portable Tablet  |                       |   | APPENDIX D:<br>Page 1 of 3      |

## 2 Composition / Information on ingredients

The Item is composed of the following ingredients:

|         |   |
|---------|---|
| H2O     | Water, 52 – 75%   |
| C8H18O3 | Diethylene glycol monobutyl ether (DGBE), 25 – 48%<br>(CAS-No. 112-34-5, EC-No. 203-961-6, EC-index-No. 603-096-00-8)<br>Relevant for safety; Refer to the respective Safety Data Sheet*. |
| NaCl    | Sodium Chloride, <1.0%  |

**Figure D-1**  
**Composition of 2.4 GHz Head Tissue Equivalent Matter**

**Note:** 2.4 GHz head liquid recipes are proprietary SPEAG. Since the composition is approximate to the actual liquids utilized, the manufacturer tissue-equivalent liquid data sheets are provided below.

### Measurement Certificate / Material Test

|              |  |
|--------------|--|
| Item Name    | Head Tissue Simulating Liquid (HSL 2450) |
| Product No.  | SL AAH 245 BA (Charge: 120112-4)         |
| Manufacturer | SPEAG                                    |

### Measurement Method

TSL dielectric parameters measured using calibrated OCP probe (type DAK).

### Target Parameters

Target parameters as defined in the IEEE 1528 and IEC 62209 compliance standards.

### Test Condition

Ambient Condition 22°C; 30% humidity  
TSL Temperature 23°C  
Test Date 18-Jan-12

### Additional Information



TSL Density 0.988 g/cm<sup>3</sup>  
TSL Heat-capacity 3.680 kJ/(kg\*K)

### Results

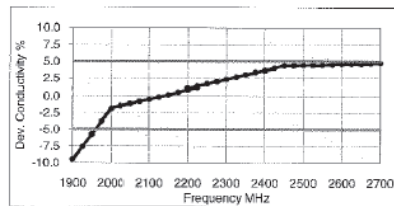
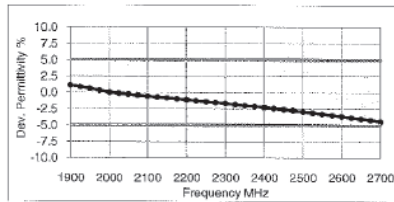
| f [MHz] | Measured |        |       |      | Target |       | Diff.to Target [%] |  |
|---------|----------|--------|-------|------|--------|-------|--------------------|--|
|         | HP-e'    | HP-e'' | sigma | eps  | sigma  | Δ-eps | Δ-sigma            |  |
| 1900    | 40.5     | 11.99  | 1.27  | 40.0 | 1.40   | 1.1   | -9.5               |  |
| 1925    | 40.3     | 12.08  | 1.29  | 40.0 | 1.40   | 0.9   | -7.6               |  |
| 1950    | 40.2     | 12.17  | 1.32  | 40.0 | 1.40   | 0.6   | -5.7               |  |
| 1975    | 40.1     | 12.26  | 1.35  | 40.0 | 1.40   | 0.3   | -3.8               |  |
| 2000    | 40.0     | 12.35  | 1.37  | 40.0 | 1.40   | 0.0   | -1.9               |  |
| 2025    | 39.9     | 12.44  | 1.40  | 40.0 | 1.42   | -0.1  | -1.5               |  |
| 2050    | 39.8     | 12.53  | 1.43  | 39.9 | 1.44   | -0.3  | -1.1               |  |
| 2075    | 39.7     | 12.60  | 1.46  | 39.9 | 1.47   | -0.4  | -0.8               |  |
| 2100    | 39.6     | 12.68  | 1.48  | 39.8 | 1.49   | -0.6  | -0.5               |  |
| 2125    | 39.5     | 12.76  | 1.51  | 39.8 | 1.51   | -0.7  | -0.2               |  |
| 2150    | 39.4     | 12.84  | 1.54  | 39.7 | 1.53   | -0.8  | 0.2                |  |
| 2175    | 39.3     | 12.93  | 1.56  | 39.7 | 1.56   | -1.0  | 0.6                |  |
| 2200    | 39.2     | 13.02  | 1.59  | 39.6 | 1.59   | -1.1  | 1.0                |  |
| 2225    | 39.1     | 13.09  | 1.62  | 39.6 | 1.60   | -1.3  | 1.3                |  |
| 2250    | 39.0     | 13.17  | 1.65  | 39.6 | 1.62   | -1.4  | 1.6                |  |
| 2275    | 38.9     | 13.25  | 1.68  | 39.5 | 1.64   | -1.5  | 2.0                |  |
| 2300    | 38.8     | 13.33  | 1.71  | 39.5 | 1.67   | -1.7  | 2.3                |  |
| 2325    | 38.7     | 13.40  | 1.73  | 39.4 | 1.69   | -1.8  | 2.7                |  |
| 2350    | 38.6     | 13.48  | 1.76  | 39.4 | 1.71   | -2.0  | 3.0                |  |
| 2375    | 38.5     | 13.56  | 1.79  | 39.3 | 1.73   | -2.1  | 3.3                |  |
| 2400    | 38.4     | 13.63  | 1.82  | 39.3 | 1.76   | -2.3  | 3.7                |  |
| 2425    | 38.3     | 13.71  | 1.85  | 39.2 | 1.78   | -2.4  | 4.0                |  |
| 2450    | 38.2     | 13.78  | 1.88  | 39.2 | 1.80   | -2.6  | 4.4                |  |
| 2475    | 38.1     | 13.85  | 1.91  | 39.2 | 1.83   | -2.7  | 4.4                |  |
| 2500    | 38.0     | 13.93  | 1.94  | 39.1 | 1.85   | -2.9  | 4.4                |  |
| 2525    | 37.9     | 13.99  | 1.97  | 39.1 | 1.88   | -3.1  | 4.4                |  |
| 2550    | 37.8     | 14.06  | 1.99  | 39.1 | 1.91   | -3.3  | 4.4                |  |
| 2575    | 37.7     | 14.13  | 2.02  | 39.0 | 1.94   | -3.5  | 4.5                |  |
| 2600    | 37.6     | 14.20  | 2.05  | 39.0 | 1.96   | -3.7  | 4.6                |  |
| 2625    | 37.5     | 14.28  | 2.08  | 39.0 | 1.99   | -3.8  | 4.6                |  |
| 2650    | 37.4     | 14.32  | 2.11  | 38.9 | 2.02   | -4.0  | 4.6                |  |
| 2675    | 37.3     | 14.39  | 2.14  | 38.9 | 2.05   | -4.3  | 4.7                |  |
| 2700    | 37.1     | 14.46  | 2.17  | 38.9 | 2.07   | -4.5  | 4.8                |  |



**Figure D-2**  
**2.4 GHz Head Tissue Equivalent Matter**

|  |   |                       |   |                                 |
|--|---|-----------------------|---|---------------------------------|
| FCC ID: A3LSMT331                      |  | SAR EVALUATION REPORT |  | Reviewed by:<br>Quality Manager |
| Test Dates:<br>01/06/2014 – 01/24/2014 | DUT Type:<br>Portable Tablet  |                       |   | APPENDIX D:<br>Page 2 of 3      |

## 2 Composition / Information on ingredients

The Item is composed of the following ingredients:

|             |          |
|-------------|----------|
| Water       | 50 – 65% |
| Mineral oil | 10 – 30% |
| Emulsifiers | 8 – 25%  |
| Sodium salt | 0 – 1.5% |

**Figure D-3**  
**Composition of 5 GHz Head Tissue Equivalent Matter**

**Note:** 5GHz head liquid recipes are proprietary SPEAG. Since the composition is approximate to the actual liquids utilized, the manufacturer tissue-equivalent liquid data sheets are provided below.

### Measurement Certificate / Material Test

|              |   |
|--------------|---|
| Item Name    | Head Tissue Simulating Liquid (HBBL3500-5800V5) |
| Product No.  | SL AAH 502 AB (Charge: 120402-2)                |
| Manufacturer | SPEAG   |

### Measurement Method

TSL dielectric parameters measured using calibrated OCP probe (type DAK).

### Target Parameters

Target parameters as defined in the IEEE 1528 and IEC 62209 compliance standards.

### Test Condition

Ambient Condition 22°C ; 30% humidity  
TSL Temperature 22°C  
Test Date 4-Apr-12

### Additional Information



TSL Density 0.985 g/cm<sup>3</sup>  
TSL Heat-capacity 3.383 kJ/(kg\*K)

### Results

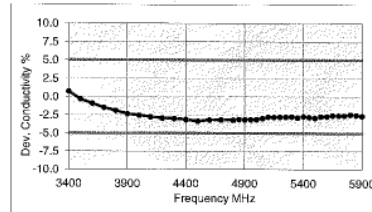
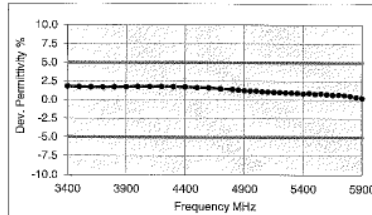
| f [MHz] | Measured |        |       | Target |       | Diff. to Target [%] |         |
|---------|----------|--------|-------|--------|-------|---------------------|---------|
|         | HP-e'    | HP-e'' | sigma | eps    | sigma | Δ-eps               | Δ-sigma |
| 3400    | 38.7     | 14.96  | 2.83  | 38.0   | 2.81  | 1.8                 | 0.7     |
| 3500    | 38.8     | 14.91  | 2.90  | 37.9   | 2.91  | 1.7                 | -0.3    |
| 3600    | 38.5     | 14.92  | 2.99  | 37.8   | 3.02  | 1.7                 | -0.9    |
| 3700    | 38.3     | 14.92  | 3.07  | 37.7   | 3.12  | 1.7                 | -1.5    |
| 3800    | 38.2     | 14.94  | 3.16  | 37.6   | 3.22  | 1.7                 | -1.9    |
| 3900    | 38.1     | 14.95  | 3.24  | 37.5   | 3.32  | 1.7                 | -2.4    |
| 4000    | 38.0     | 15.00  | 3.34  | 37.4   | 3.43  | 1.8                 | -2.5    |
| 4100    | 37.9     | 15.04  | 3.43  | 37.2   | 3.53  | 1.8                 | -2.6    |
| 4200    | 37.8     | 15.08  | 3.52  | 37.1   | 3.63  | 1.8                 | -2.9    |
| 4300    | 37.7     | 15.14  | 3.62  | 37.0   | 3.73  | 1.8                 | -3.0    |
| 4400    | 37.5     | 15.18  | 3.71  | 36.9   | 3.84  | 1.7                 | -3.1    |
| 4500    | 37.4     | 15.20  | 3.81  | 36.8   | 3.94  | 1.6                 | -3.3    |
| 4600    | 37.3     | 15.29  | 3.91  | 36.7   | 4.04  | 1.6                 | -3.2    |
| 4700    | 37.1     | 15.34  | 4.01  | 36.6   | 4.14  | 1.5                 | -3.2    |
| 4800    | 37.0     | 15.39  | 4.11  | 36.4   | 4.25  | 1.4                 | -3.2    |
| 4850    | 36.9     | 15.43  | 4.16  | 36.4   | 4.30  | 1.3                 | -3.1    |
| 4900    | 36.8     | 15.45  | 4.21  | 36.3   | 4.35  | 1.3                 | -3.1    |
| 4950    | 36.7     | 15.47  | 4.26  | 36.3   | 4.40  | 1.2                 | -3.1    |
| 5000    | 36.7     | 15.50  | 4.31  | 36.2   | 4.45  | 1.2                 | -3.1    |
| 5050    | 36.6     | 15.55  | 4.37  | 36.2   | 4.50  | 1.1                 | -3.0    |
| 5100    | 36.5     | 15.60  | 4.43  | 36.1   | 4.55  | 1.1                 | -2.8    |
| 5150    | 36.4     | 15.62  | 4.48  | 36.0   | 4.60  | 1.0                 | -2.8    |
| 5200    | 36.4     | 15.65  | 4.53  | 36.0   | 4.66  | 1.0                 | -2.8    |
| 5250    | 36.3     | 15.67  | 4.58  | 35.9   | 4.71  | 1.0                 | -2.8    |
| 5300    | 36.2     | 15.70  | 4.63  | 35.9   | 4.76  | 1.0                 | -2.7    |
| 5350    | 36.1     | 15.70  | 4.67  | 35.8   | 4.81  | 0.9                 | -2.9    |
| 5400    | 36.1     | 15.74  | 4.73  | 35.8   | 4.86  | 0.8                 | -2.7    |
| 5450    | 36.0     | 15.75  | 4.77  | 35.7   | 4.91  | 0.9                 | -2.8    |
| 5500    | 35.9     | 15.75  | 4.82  | 35.6   | 4.96  | 0.8                 | -2.9    |
| 5550    | 35.9     | 15.80  | 4.88  | 35.6   | 5.01  | 0.8                 | -2.7    |
| 5600    | 35.8     | 15.82  | 4.93  | 35.5   | 5.07  | 0.7                 | -2.7    |
| 5650    | 35.7     | 15.86  | 4.98  | 35.5   | 5.12  | 0.7                 | -2.6    |
| 5700    | 35.7     | 15.88  | 5.03  | 35.4   | 5.17  | 0.7                 | -2.6    |
| 5750    | 35.6     | 15.90  | 5.08  | 35.4   | 5.22  | 0.6                 | -2.6    |
| 5800    | 35.5     | 15.94  | 5.14  | 35.3   | 5.27  | 0.6                 | -2.4    |
| 5850    | 35.4     | 15.98  | 5.20  | 35.3   | 5.34  | 0.4                 | -2.5    |
| 5900    | 35.4     | 16.02  | 5.26  | 35.3   | 5.40  | 0.2                 | -2.6    |



**Figure D-4**  
**5GHz Head Tissue Equivalent Matter**

|  |   |                       |   |                                 |
|--|---|-----------------------|---|---------------------------------|
| FCC ID: A3LSMT331                      |  | SAR EVALUATION REPORT |  | Reviewed by:<br>Quality Manager |
| Test Dates:<br>01/06/2014 – 01/24/2014 | DUT Type:<br>Portable Tablet  |                       |   | APPENDIX D:<br>Page 3 of 3      |

## APPENDIX E: SAR SYSTEM VALIDATION



Per FCC KDB 865664 D02v01, SAR system validation status should be documented to confirm measurement accuracy. The SAR systems (including SAR probes, system components and software versions) used for this device were validated against its performance specifications prior to the SAR measurements. Reference dipoles were used with the required tissue- equivalent media for system validation, according to the procedures outlined in FCC KDB 865664 D01 v01 and IEEE 1528-2013. Since SAR probe calibrations are frequency dependent, each probe calibration point was validated at a frequency within the valid frequency range of the probe calibration point, using the system that normally operates with the probe for routine SAR measurements and according to the required tissue-equivalent media.

A tabulated summary of the system validation status including the validation date(s), measurement frequencies, SAR probes and tissue dielectric parameters has been included.



**Table E-I**  
**SAR System Validation Summary**

| SAR SYSTEM # | FREQ. [MHz] | DATE       | PROBE SN | PROBE TYPE | PROBE CAL. POINT |      | COND. | PERM.             | CW VALIDATION |                 |                | MOD. VALIDATION |             |      |
|--------------|-------------|------------|----------|------------|------------------|------|-------|-------------------|---------------|-----------------|----------------|-----------------|-------------|------|
|              |             |            |          |            |                  |      | (σ)   | (ε <sub>r</sub> ) | SENSI-TIVITY  | PROBE LINEARITY | PROBE ISOTROPY | MOD. TYPE       | DUTY FACTOR | PAR  |
| D            | 835         | 10/7/2013  | 3022     | ES3DV2     | 835              | Head | 0.910 | 39.82             | PASS          | PASS            | PASS           | GMSK            | PASS        | N/A  |
| G            | 1900        | 12/16/2013 | 3209     | ES3DV3     | 1900             | Head | 1.437 | 38.75             | PASS          | PASS            | PASS           | GMSK            | PASS        | N/A  |
| C            | 2450        | 8/12/2013  | 3263     | ES3DV3     | 2450             | Head | 1.863 | 38.51             | PASS          | PASS            | PASS           | OFDM            | N/A         | PASS |
| E            | 5200        | 12/3/2013  | 3914     | EX3DV4     | 5200             | Head | 4.482 | 34.70             | PASS          | PASS            | PASS           | OFDM            | N/A         | PASS |
| E            | 5300        | 12/3/2013  | 3914     | EX3DV4     | 5300             | Head | 4.604 | 34.60             | PASS          | PASS            | PASS           | OFDM            | N/A         | PASS |
| E            | 5600        | 12/3/2013  | 3914     | EX3DV4     | 5600             | Head | 4.907 | 34.13             | PASS          | PASS            | PASS           | OFDM            | N/A         | PASS |
| E            | 5800        | 12/3/2013  | 3914     | EX3DV4     | 5800             | Head | 5.133 | 33.89             | PASS          | PASS            | PASS           | OFDM            | N/A         | PASS |
| D            | 835         | 10/8/2013  | 3022     | ES3DV2     | 835              | Body | 1.012 | 53.65             | PASS          | PASS            | PASS           | GMSK            | PASS        | N/A  |
| K            | 835         | 12/19/2013 | 3333     | ES3DV3     | 835              | Body | 1.006 | 53.18             | PASS          | PASS            | PASS           | GMSK            | PASS        | N/A  |
| I            | 1900        | 7/1/2013   | 3319     | ES3DV3     | 1900             | Body | 1.502 | 52.10             | PASS          | PASS            | PASS           | GMSK            | PASS        | N/A  |
| K            | 1900        | 1/15/2014  | 3333     | ES3DV3     | 1900             | Body | 1.539 | 51.48             | PASS          | PASS            | PASS           | GMSK            | PASS        | N/A  |
| G            | 2450        | 1/17/2014  | 3209     | ES3DV3     | 2450             | Body | 2.041 | 50.75             | PASS          | PASS            | PASS           | OFDM            | N/A         | PASS |
| K            | 2450        | 1/23/2014  | 3333     | ES3DV3     | 2450             | Body | 1.944 | 50.34             | PASS          | PASS            | PASS           | OFDM            | N/A         | PASS |
| E            | 5200        | 12/7/2013  | 3914     | EX3DV4     | 5200             | Body | 5.330 | 48.16             | PASS          | PASS            | PASS           | OFDM            | N/A         | PASS |
| E            | 5300        | 12/7/2013  | 3914     | EX3DV4     | 5300             | Body | 5.481 | 47.91             | PASS          | PASS            | PASS           | OFDM            | N/A         | PASS |
| E            | 5500        | 12/7/2013  | 3914     | EX3DV4     | 5500             | Body | 5.807 | 47.39             | PASS          | PASS            | PASS           | OFDM            | N/A         | PASS |
| E            | 5600        | 12/7/2013  | 3914     | EX3DV4     | 5600             | Body | 5.933 | 47.15             | PASS          | PASS            | PASS           | OFDM            | N/A         | PASS |
| E            | 5800        | 12/7/2013  | 3914     | EX3DV4     | 5800             | Body | 6.240 | 46.70             | PASS          | PASS            | PASS           | OFDM            | N/A         | PASS |

NOTE: While the probes have been calibrated for both a CW and modulated signals, all measurements were performed using communication systems calibrated for CW signals only. Modulations in the table above represent test configurations for which the measurement system has been validated per FCC KDB Publication 865664 D01v01 for scenarios when CW probe calibrations are used with other signal types. SAR systems were validated for modulated signals with a periodic duty cycle, such as GMSK, or with a high peak to average ratio (>5 dB), such as OFDM according to KDB 865664.

|  |  |                              |   |                                 |
|--|--|------------------------------|---|---------------------------------|
| FCC ID: A3LSMT331                      |  <b>PCTEST</b><br><small>ENGINEERING LABORATORY, INC.</small> | <b>SAR EVALUATION REPORT</b> |  | Reviewed by:<br>Quality Manager |
| Test Dates:<br>01/06/2014 – 01/24/2014 | DUT Type:<br>Portable Tablet   |                              |   | APPENDIX E:<br>Page 1 of 1      |

# APPENDIX G: SENSOR TRIGGERING DATA SUMMARY

|   |   |                              |   |  |
|---|---|------------------------------|---|--|
| <b>FCC ID:</b> A3LSMT331                    |  | <b>SAR EVALUATION REPORT</b> |  | <b>Reviewed by:</b><br>Quality Manager |
| <b>Test Dates:</b><br>01/06/2014-01/24/2014 | <b>DUT Type:</b><br>Portable Tablet   |                              |   | <b>APPENDIX G:</b><br>Page 1 of 4      |

## A3LSMT331 Sensor Triggering Data Summary

Per FCC KDB Publication 616217 D04v01, this device was tested by the manufacturer to determine the proximity sensor triggering distances for the back and left edge of the device. The measured output power within  $\pm 5$  mm of the triggering points (or until touching the phantom) is included for back side and each applicable edge.



To ensure all production units are compliant it is necessary to test SAR at a distance 1 mm less than the smallest distance from the device and SAR phantom (determined from these triggering tests according to the KDB 616217 D04v01) with the device at maximum output power without power reduction. These SAR Tests are included in addition to the SAR tests for the device touching the SAR phantom, with reduced power.

The operational description contains information explaining how this device remains compliant in the event of a sensor malfunction.

### Back Side

Moving device toward the phantom:



| KDB 616217 6.2.6     |       |       |       |       |       |       |       |       |       |       |       |
|----------------------|-------|-------|-------|-------|-------|-------|-------|-------|-------|-------|-------|
| Measured Power [dBm] |       |       |       |       |       |       |       |       |       |       |       |
| Distance[mm]         | 18    | 17    | 16    | 15    | 14    | 13    | 12    | 11    | 10    | 9     | 8     |
| GSM850               | 33.21 | 33.22 | 33.27 | 33.19 | 33.18 | 30.17 | 30.29 | 30.16 | 30.46 | 30.47 | 30.21 |
| GSM1900              | 30.42 | 30.34 | 30.38 | 30.25 | 30.44 | 23.22 | 23.39 | 23.46 | 23.33 | 23.23 | 23.17 |
| GPRS850 1Tx          | 33.40 | 33.15 | 33.32 | 33.43 | 33.29 | 30.21 | 30.21 | 30.48 | 30.27 | 30.31 | 30.21 |
| GPRS850 2Tx          | 30.21 | 30.47 | 30.18 | 30.24 | 30.40 | 26.65 | 26.66 | 26.92 | 26.87 | 26.96 | 26.66 |
| GPRS850 3Tx          | 28.75 | 28.66 | 28.65 | 28.82 | 28.70 | 25.94 | 25.82 | 25.67 | 25.73 | 25.69 | 25.90 |
| GPRS850 4Tx          | 26.75 | 26.74 | 26.65 | 26.92 | 26.85 | 23.80 | 23.72 | 23.68 | 23.72 | 23.93 | 23.78 |
| GPRS1900 1Tx         | 30.38 | 30.35 | 30.26 | 30.19 | 30.25 | 23.38 | 23.37 | 23.15 | 23.46 | 23.41 | 23.35 |
| GPRS1900 2Tx         | 28.29 | 28.23 | 28.19 | 28.23 | 28.31 | 20.79 | 20.81 | 20.92 | 20.70 | 20.70 | 20.68 |
| GPRS1900 3Tx         | 26.24 | 26.33 | 26.43 | 26.42 | 26.45 | 18.87 | 18.66 | 18.75 | 18.66 | 18.81 | 18.87 |
| GPRS1900 4Tx         | 24.69 | 24.76 | 24.67 | 24.65 | 24.70 | 17.99 | 17.71 | 17.66 | 17.97 | 17.73 | 17.78 |
| WCDMA850             | 23.24 | 23.22 | 23.38 | 23.41 | 23.24 | 21.63 | 21.68 | 21.82 | 21.83 | 21.85 | 21.65 |
| WCDMA1900            | 21.72 | 21.77 | 21.86 | 21.65 | 21.96 | 14.17 | 14.37 | 14.32 | 14.42 | 14.17 | 14.28 |
| EDGE850 1Tx          | 26.93 | 26.84 | 26.93 | 26.79 | 26.90 | 25.28 | 25.42 | 25.15 | 25.31 | 25.40 | 25.39 |
| EDGE850 2Tx          | 26.26 | 26.45 | 26.31 | 26.17 | 26.31 | 25.27 | 25.16 | 25.35 | 25.29 | 25.22 | 25.30 |
| EDGE850 3Tx          | 26.39 | 26.20 | 26.26 | 26.17 | 26.31 | 25.49 | 25.16 | 25.28 | 25.34 | 25.37 | 25.23 |
| EDGE850 4Tx          | 22.79 | 22.79 | 22.78 | 22.97 | 22.90 | 22.86 | 22.75 | 22.85 | 22.88 | 22.87 | 22.81 |
| EDGE1900 1Tx         | 25.43 | 25.42 | 25.48 | 25.43 | 25.26 | 22.28 | 22.44 | 22.29 | 22.26 | 22.30 | 22.25 |
| EDGE1900 2Tx         | 25.39 | 25.22 | 25.31 | 25.44 | 25.28 | 19.88 | 19.66 | 19.73 | 19.87 | 19.85 | 19.91 |
| EDGE1900 3Tx         | 24.66 | 24.77 | 24.65 | 24.90 | 24.79 | 18.26 | 18.38 | 18.27 | 18.27 | 18.45 | 18.46 |
| EDGE1900 4Tx         | 21.78 | 21.92 | 21.91 | 21.93 | 21.71 | 17.28 | 17.32 | 17.16 | 17.35 | 17.26 | 17.16 |

|                                      |  |                            |   |                                 |
|--------------------------------------|--|----------------------------|---|---------------------------------|
| FCC ID: A3LSMT331                    |  PCTEST<br>ENGINEERING LABORATORY, INC. | SAR EVALUATION REPORT      |  | Reviewed by:<br>Quality Manager |
| Test Dates:<br>01/06/2014-01/24/2014 | DUT Type:<br>Portable Tablet   | APPENDIX G:<br>Page 2 of 4 |   |                                 |

Moving device away from the phantom:

| KDB 616217 6.2.8     |       |       |       |       |       |       |       |       |       |       |       |       |       |       |       |       |       |
|----------------------|-------|-------|-------|-------|-------|-------|-------|-------|-------|-------|-------|-------|-------|-------|-------|-------|-------|
| Measured Power [dBm] |       |       |       |       |       |       |       |       |       |       |       |       |       |       |       |       |       |
| Distance[mm]         | 25    | 22    | 19    | 18    | 17    | 16    | 15    | 14    | 13    | 12    | 11    | 10    | 9     | 8     | 5     | 2     | 0     |
| GSM850               | 33.45 | 33.29 | 33.32 | 33.22 | 33.29 | 33.43 | 33.32 | 33.48 | 30.23 | 30.47 | 30.48 | 30.17 | 30.43 | 30.25 | 30.34 | 30.43 | 30.21 |
| GSM1900              | 30.41 | 30.41 | 30.33 | 30.29 | 30.45 | 30.28 | 30.49 | 30.17 | 23.29 | 23.46 | 23.45 | 23.45 | 23.33 | 23.18 | 23.32 | 23.21 | 23.23 |
| GPRS850 1Tx          | 33.39 | 33.41 | 33.44 | 33.41 | 33.33 | 33.49 | 33.22 | 33.30 | 30.40 | 30.27 | 30.29 | 30.25 | 30.27 | 30.48 | 30.47 | 30.22 | 30.28 |
| GPRS850 2Tx          | 30.22 | 30.49 | 30.31 | 30.46 | 30.39 | 30.47 | 30.29 | 30.25 | 26.70 | 26.84 | 26.86 | 26.83 | 26.98 | 26.98 | 26.81 | 26.98 | 26.96 |
| GPRS850 3Tx          | 28.81 | 28.71 | 28.91 | 28.98 | 28.73 | 28.95 | 28.90 | 28.73 | 25.70 | 25.76 | 25.66 | 25.89 | 25.96 | 25.92 | 25.93 | 25.90 | 25.88 |
| GPRS850 4Tx          | 26.66 | 26.66 | 26.94 | 26.72 | 26.70 | 26.70 | 26.81 | 26.72 | 23.76 | 23.87 | 23.77 | 23.78 | 23.93 | 23.78 | 23.93 | 23.95 | 23.74 |
| GPRS1900 1Tx         | 30.33 | 30.27 | 30.49 | 30.23 | 30.45 | 30.43 | 30.32 | 30.48 | 23.46 | 23.38 | 23.26 | 23.37 | 23.22 | 23.16 | 23.19 | 23.40 | 23.22 |
| GPRS1900 2Tx         | 28.35 | 28.18 | 28.39 | 28.32 | 28.21 | 28.19 | 28.38 | 28.40 | 20.76 | 20.84 | 20.85 | 20.82 | 20.98 | 20.87 | 20.90 | 20.97 | 20.94 |
| GPRS1900 3Tx         | 26.15 | 26.44 | 26.33 | 26.20 | 26.36 | 26.40 | 26.31 | 26.19 | 18.97 | 18.88 | 18.88 | 18.72 | 18.67 | 18.95 | 18.70 | 18.78 | 18.78 |
| GPRS1900 4Tx         | 24.81 | 24.67 | 24.86 | 24.95 | 24.84 | 24.93 | 24.67 | 24.90 | 17.97 | 17.77 | 17.98 | 17.95 | 17.69 | 17.82 | 17.70 | 17.69 | 17.81 |
| WCDMA850             | 23.25 | 23.45 | 23.45 | 23.30 | 23.17 | 23.33 | 23.19 | 23.32 | 21.79 | 21.76 | 21.76 | 21.76 | 21.88 | 21.88 | 21.78 | 21.75 | 21.86 |
| WCDMA1900            | 21.76 | 21.87 | 21.97 | 21.80 | 21.98 | 21.67 | 21.91 | 21.67 | 14.35 | 14.49 | 14.45 | 14.45 | 14.32 | 14.39 | 14.39 | 14.30 | 14.39 |
| EDGE850 1Tx          | 26.78 | 26.96 | 26.99 | 26.80 | 26.78 | 26.95 | 26.95 | 26.78 | 25.48 | 25.46 | 25.38 | 25.36 | 25.33 | 25.19 | 25.19 | 25.46 | 25.21 |
| EDGE850 2Tx          | 26.46 | 26.44 | 26.16 | 26.26 | 26.32 | 26.35 | 26.48 | 26.40 | 25.31 | 25.21 | 25.48 | 25.29 | 25.23 | 25.41 | 25.43 | 25.18 | 25.49 |
| EDGE850 3Tx          | 26.49 | 26.21 | 26.31 | 26.31 | 26.20 | 26.46 | 26.37 | 26.38 | 25.22 | 25.42 | 25.15 | 25.40 | 25.30 | 25.43 | 25.30 | 25.34 | 25.45 |
| EDGE850 4Tx          | 22.74 | 22.83 | 22.96 | 22.83 | 22.97 | 22.85 | 22.71 | 22.71 | 22.84 | 22.74 | 22.94 | 22.78 | 22.95 | 22.81 | 22.98 | 22.71 | 22.75 |
| EDGE1900 1Tx         | 25.22 | 25.31 | 25.35 | 25.25 | 25.45 | 25.32 | 25.15 | 25.20 | 22.15 | 22.16 | 22.31 | 22.37 | 22.19 | 22.32 | 22.49 | 22.21 | 22.32 |
| EDGE1900 2Tx         | 25.48 | 25.29 | 25.22 | 25.17 | 25.42 | 25.18 | 25.40 | 25.15 | 19.67 | 19.83 | 19.96 | 19.93 | 19.84 | 19.88 | 19.77 | 19.69 | 19.69 |
| EDGE1900 3Tx         | 24.83 | 24.77 | 24.75 | 24.85 | 24.67 | 24.81 | 24.74 | 24.90 | 18.26 | 18.16 | 18.45 | 18.31 | 18.21 | 18.43 | 18.16 | 18.34 | 18.33 |
| EDGE1900 4Tx         | 21.92 | 21.79 | 21.88 | 21.77 | 21.92 | 21.97 | 21.82 | 21.89 | 17.28 | 17.30 | 17.42 | 17.37 | 17.36 | 17.24 | 17.34 | 17.25 | 17.31 |

Based on the most conservative measured triggering distance of 13 mm, additional SAR measurements were required at 12 mm from the back side.

|                                      |   |                              |   |                                 |
|--------------------------------------|---|------------------------------|---|---------------------------------|
| FCC ID: A3LSMT331                    |  <b>PCTEST</b><br>ENGINEERING LABORATORY, INC. | <b>SAR EVALUATION REPORT</b> |  | Reviewed by:<br>Quality Manager |
| Test Dates:<br>01/06/2014-01/24/2014 | DUT Type:<br>Portable Tablet  | APPENDIX G:<br>Page 3 of 4   |   |                                 |

## Top Edge



Moving device toward the phantom:

| KDB 616217 6.2.6     |       |       |       |       |       |       |       |       |       |       |       |
|----------------------|-------|-------|-------|-------|-------|-------|-------|-------|-------|-------|-------|
| Measured Power [dBm] |       |       |       |       |       |       |       |       |       |       |       |
| Distance[mm]         | 15    | 14    | 13    | 12    | 11    | 10    | 9     | 8     | 7     | 6     | 5     |
| GSM850               | 33.37 | 33.41 | 33.24 | 33.42 | 33.30 | 30.42 | 30.25 | 30.43 | 30.37 | 30.36 | 30.23 |
| GSM1900              | 30.32 | 30.26 | 30.48 | 30.17 | 30.21 | 23.33 | 23.16 | 23.36 | 23.26 | 23.47 | 23.34 |
| GPRS850 1Tx          | 33.40 | 33.29 | 33.38 | 33.38 | 33.25 | 30.16 | 30.31 | 30.35 | 30.15 | 30.28 | 30.18 |
| GPRS850 2Tx          | 30.49 | 30.47 | 30.32 | 30.34 | 30.35 | 26.87 | 26.89 | 26.89 | 26.82 | 26.81 | 26.65 |
| GPRS850 3Tx          | 28.73 | 28.75 | 28.73 | 28.92 | 28.99 | 25.91 | 25.83 | 25.78 | 25.88 | 25.97 | 25.67 |
| GPRS850 4Tx          | 26.91 | 26.82 | 26.89 | 26.90 | 26.65 | 23.72 | 23.67 | 23.79 | 23.87 | 23.97 | 23.86 |
| GPRS1900 1Tx         | 30.40 | 30.33 | 30.34 | 30.36 | 30.44 | 23.24 | 23.43 | 23.41 | 23.42 | 23.41 | 23.44 |
| GPRS1900 2Tx         | 28.32 | 28.29 | 28.39 | 28.42 | 28.32 | 20.69 | 20.65 | 20.90 | 20.67 | 20.78 | 20.86 |
| GPRS1900 3Tx         | 26.19 | 26.26 | 26.16 | 26.16 | 26.34 | 18.84 | 18.97 | 18.67 | 18.73 | 18.84 | 18.91 |
| GPRS1900 4Tx         | 24.71 | 24.91 | 24.85 | 24.68 | 24.85 | 17.76 | 17.94 | 17.88 | 17.90 | 17.73 | 17.99 |
| WCDMA850             | 23.20 | 23.43 | 23.30 | 23.15 | 23.43 | 21.56 | 21.75 | 21.69 | 21.75 | 21.59 | 21.72 |
| WCDMA1900            | 21.99 | 21.76 | 21.90 | 21.83 | 21.84 | 14.48 | 14.43 | 14.41 | 14.48 | 14.45 | 14.32 |
| EDGE850 1Tx          | 26.75 | 26.79 | 26.97 | 26.95 | 26.74 | 25.46 | 25.29 | 25.27 | 25.33 | 25.30 | 25.41 |
| EDGE850 2Tx          | 26.15 | 26.37 | 26.20 | 26.37 | 26.19 | 25.19 | 25.29 | 25.33 | 25.47 | 25.34 | 25.20 |
| EDGE850 3Tx          | 26.18 | 26.47 | 26.33 | 26.19 | 26.40 | 25.44 | 25.15 | 25.20 | 25.33 | 25.44 | 25.18 |
| EDGE850 4Tx          | 22.89 | 22.67 | 22.65 | 22.75 | 22.92 | 22.83 | 22.99 | 22.91 | 22.72 | 22.69 | 22.85 |
| EDGE1900 1Tx         | 25.38 | 25.19 | 25.26 | 25.27 | 25.46 | 22.26 | 22.17 | 22.34 | 22.27 | 22.21 | 22.32 |
| EDGE1900 2Tx         | 25.18 | 25.48 | 25.37 | 25.22 | 25.39 | 19.91 | 19.91 | 19.94 | 19.67 | 19.69 | 19.83 |
| EDGE1900 3Tx         | 24.80 | 24.89 | 24.84 | 24.72 | 24.92 | 18.29 | 18.47 | 18.32 | 18.29 | 18.36 | 18.40 |
| EDGE1900 4Tx         | 21.94 | 21.65 | 21.68 | 21.87 | 21.90 | 17.27 | 17.24 | 17.15 | 17.30 | 17.39 | 17.16 |

Moving device away from the phantom:

| KDB 616217 6.2.8     |       |       |       |       |       |       |       |       |       |       |       |       |       |       |       |
|----------------------|-------|-------|-------|-------|-------|-------|-------|-------|-------|-------|-------|-------|-------|-------|-------|
| Measured Power [dBm] |       |       |       |       |       |       |       |       |       |       |       |       |       |       |       |
| Distance[mm]         | 21    | 18    | 15    | 14    | 13    | 12    | 11    | 10    | 9     | 8     | 7     | 6     | 5     | 2     | 0     |
| GSM850               | 33.35 | 33.32 | 33.19 | 33.24 | 33.20 | 33.40 | 33.16 | 30.34 | 30.16 | 30.34 | 30.39 | 30.20 | 30.45 | 30.29 | 30.43 |
| GSM1900              | 30.25 | 30.35 | 30.48 | 30.38 | 30.15 | 30.42 | 30.44 | 23.20 | 23.24 | 23.40 | 23.24 | 23.41 | 23.31 | 23.39 | 23.39 |
| GPRS850 1Tx          | 33.29 | 33.43 | 33.28 | 33.27 | 33.47 | 33.42 | 33.34 | 30.22 | 30.22 | 30.42 | 30.35 | 30.39 | 30.40 | 30.47 | 30.18 |
| GPRS850 2Tx          | 30.19 | 30.48 | 30.23 | 30.22 | 30.31 | 30.48 | 30.23 | 26.93 | 26.70 | 26.82 | 26.83 | 26.87 | 26.94 | 26.86 | 26.87 |
| GPRS850 3Tx          | 28.99 | 28.81 | 28.68 | 28.86 | 28.75 | 28.94 | 28.81 | 25.98 | 25.73 | 25.88 | 25.97 | 25.77 | 25.66 | 25.87 | 25.99 |
| GPRS850 4Tx          | 26.91 | 26.82 | 26.91 | 26.82 | 26.88 | 26.94 | 26.91 | 23.87 | 23.96 | 23.78 | 23.94 | 23.69 | 23.88 | 23.97 | 23.82 |
| GPRS1900 1Tx         | 30.31 | 30.41 | 30.25 | 30.34 | 30.22 | 30.49 | 30.46 | 23.34 | 23.27 | 23.33 | 23.43 | 23.34 | 23.49 | 23.40 | 23.31 |
| GPRS1900 2Tx         | 28.41 | 28.35 | 28.31 | 28.36 | 28.49 | 28.29 | 28.40 | 20.98 | 20.99 | 20.90 | 20.84 | 20.85 | 20.98 | 20.69 | 20.76 |
| GPRS1900 3Tx         | 26.37 | 26.29 | 26.42 | 26.17 | 26.46 | 26.21 | 26.30 | 18.99 | 18.93 | 18.79 | 18.88 | 18.67 | 18.86 | 18.78 | 18.66 |
| GPRS1900 4Tx         | 24.94 | 24.98 | 24.75 | 24.79 | 24.71 | 24.95 | 24.73 | 17.76 | 17.72 | 17.65 | 17.90 | 17.97 | 17.67 | 17.81 | 17.76 |
| WCDMA850             | 23.16 | 23.45 | 23.37 | 23.49 | 23.29 | 23.41 | 23.42 | 21.88 | 21.63 | 21.60 | 21.70 | 21.60 | 21.58 | 21.61 | 21.67 |
| WCDMA1900            | 21.82 | 21.84 | 21.78 | 21.69 | 21.98 | 21.80 | 21.85 | 14.35 | 14.22 | 14.39 | 14.37 | 14.42 | 14.26 | 14.34 | 14.24 |
| EDGE850 1Tx          | 26.99 | 26.85 | 26.67 | 26.92 | 26.78 | 26.95 | 26.99 | 25.27 | 25.31 | 25.15 | 25.35 | 25.28 | 25.35 | 25.42 | 25.19 |
| EDGE850 2Tx          | 26.39 | 26.42 | 26.30 | 26.30 | 26.16 | 26.41 | 26.36 | 25.42 | 25.18 | 25.22 | 25.24 | 25.37 | 25.22 | 25.20 | 25.49 |
| EDGE850 3Tx          | 26.44 | 26.15 | 26.41 | 26.46 | 26.32 | 26.32 | 26.16 | 25.17 | 25.17 | 25.15 | 25.18 | 25.32 | 25.19 | 25.28 | 25.28 |
| EDGE850 4Tx          | 22.93 | 22.91 | 22.97 | 22.94 | 22.99 | 22.71 | 22.86 | 22.70 | 22.90 | 22.76 | 22.87 | 22.84 | 22.83 | 22.84 | 22.85 |
| EDGE1900 1Tx         | 25.48 | 25.25 | 25.45 | 25.31 | 25.29 | 25.34 | 25.32 | 22.44 | 22.15 | 22.21 | 22.33 | 22.38 | 22.42 | 22.28 | 22.29 |
| EDGE1900 2Tx         | 25.43 | 25.15 | 25.47 | 25.28 | 25.31 | 25.22 | 25.25 | 19.87 | 19.77 | 19.75 | 19.91 | 19.95 | 19.79 | 19.77 | 19.74 |
| EDGE1900 3Tx         | 24.85 | 24.77 | 24.89 | 24.76 | 24.93 | 24.79 | 24.96 | 18.30 | 18.38 | 18.40 | 18.29 | 18.43 | 18.21 | 18.17 | 18.34 |
| EDGE1900 4Tx         | 21.96 | 21.72 | 21.75 | 21.67 | 21.95 | 21.79 | 21.71 | 17.36 | 17.48 | 17.30 | 17.31 | 17.37 | 17.15 | 17.27 | 17.43 |

Based on the most conservative measured triggering distance of 10 mm, additional SAR measurements were required at 9 mm from the top edge.

|                                      |  |                            |   |                                 |
|--------------------------------------|--|----------------------------|---|---------------------------------|
| FCC ID: A3LSMT331                    |  PCTEST<br>Engineering Laboratory, Inc. | SAR EVALUATION REPORT      |  | Reviewed by:<br>Quality Manager |
| Test Dates:<br>01/06/2014-01/24/2014 | DUT Type:<br>Portable Tablet   | APPENDIX G:<br>Page 4 of 4 |   |                                 |