



FCC CFR47 PART 22 SUBPART H

WWAN

CERTIFICATION TEST REPORT

FOR

LTE Watch + Bluetooth/BLE and DTS b/g/n

MODEL NUMBER : SM-R765, SM-R765S, SM-R765K, SM-R765L

FCC ID: A3LSMR765KOR

REPORT NUMBER: 16K23792-E4V3

ISSUE DATE: SEP 01, 2016

Prepared for
SAMSUNG ELECTRONICS CO., LTD.
129 SAMSUNG-RO, YEONGTONG-GU, SUWON-SI,
GYEONGGI-DO, 16677, KOREA

Prepared by
UL Korea, Ltd. Suwon Laboratory
218 Maeyeong-ro, Yeongtong-gu,
Suwon-si, Gyeonggi-do, 16675, Korea
TEL: (031) 337-9902
FAX: (031) 213-5433



Revision History

<u>Rev.</u>	<u>Issue Date</u>	<u>Revisions</u>	<u>Revised By</u>
V1	08/26/16	Initial issue	Junwhan Lee
V2	08/30/16	Revised section 5.1, 10.3.2	Junwhan Lee
V3	09/01/16	Revised section 2	Junwhan Lee

TABLE OF CONTENTS

1. ATTESTATION OF TEST RESULTS	5
2. TEST METHODOLOGY	6
3. FACILITIES AND ACCREDITATION	6
4. CALIBRATION AND UNCERTAINTY	6
4.1. MEASURING INSTRUMENT CALIBRATION	6
4.2. SAMPLE CALCULATION	6
4.3. MEASUREMENT UNCERTAINTY	6
5. EQUIPMENT UNDER TEST	7
5.1. DESCRIPTION OF EUT	7
5.2. MAXIMUM OUTPUT POWER (LTE)	7
5.3. DESCRIPTION OF TEST SETUP	8
6. TEST AND MEASUREMENT EQUIPMENT	10
7. Summary Table	11
8. RF POWER OUTPUT VERIFICATION	12
8.1. LTE OUTPUT VERIFICATION	12
8.1.1. LTE OUTPUT POWER RESULT	13
9. PEAK TO AVERAGE RATIO	14
9.1. CONDUCTED PEAK TO AVERAGE RESULT	14
9.2. CONDUCTED PEAK TO AVERAGE PLOTS	15
10. LIMITS AND CONDUCTED RESULTS	16
10.1. OCCUPIED BANDWIDTH	16
10.1.1. OCCUPIED BANDWIDTH PLOTS	17
10.2. BAND EDGE EMISSIONS	21
10.2.1. BAND EDGE PLOTS	23
10.3. OUT OF BAND EMISSIONS	27
10.3.1. OUT OF BAND EMISSIONS RESULT	28
10.3.2. OUT OF BAND EMISSIONS PLOTS	29
10.4. FREQUENCY STABILITY	33
10.4.1. FREQUENCY STABILITY RESULTS	34
11. RADIATED TEST RESULTS	35
11.1. RADIATED POWER (ERP & EIRP)	35
11.1.1. ERP/EIRP Results	36
11.1.2. ERP/EIRP DATA	37

11.2.	FIELD STRENGTH OF SPURIOUS RADIATION	41
11.2.1.	SPURIOUS RADIATION PLOTS.....	42
12.	SETUP PHOTOS.....	46

1. ATTESTATION OF TEST RESULTS

COMPANY NAME: SAMSUNG ELECTRONICS CO., LTD.
EUT DESCRIPTION: LTE Watch + Bluetooth/BLE and DTS b/g/n
MODEL NUMBER: SM-R765, SM-R765S, SM-R765K, SM-R765L
SERIAL NUMBER: R3AH800BKLY, R3AH800BKKH,
R3AH800BKJZ, R3AH800BK9X (RADIATED);
R3AH800BKHR, R3AH800BKBM (CONDUCTED)
DATE TESTED: AUG 17, 2016 - AUG 30, 2016

APPLICABLE STANDARDS	
STANDARD	TEST RESULTS
FCC PART 22H	Pass

UL Korea, Ltd. tested the above equipment in accordance with the requirements set forth in the above standards. All indications of Pass/Fail in this report are opinions expressed by UL Korea, Ltd. based on interpretations and/or observations of test results. Measurement Uncertainties were not taken into account and are published for informational purposes only. The test results show that the equipment tested is capable of demonstrating compliance with the requirements as documented in this report.

Note: The results documented in this report apply only to the tested sample, under the conditions and modes of operation as described herein. This document may not be altered or revised in any way unless done so by UL Korea, Ltd. and all revisions are duly noted in the revisions section. Any alteration of this document not carried out by UL Korea, Ltd. will constitute fraud and shall nullify the document. This report must not be used by the client to claim product certification, approval, or endorsement by IAS, any agency of the Federal Government, or any agency of any government.

Approved & Released For
UL Korea, Ltd. By:



CY Choi
Suwon Lab Engineer
UL Korea, Ltd.

Tested By:



Junwhan Lee
Suwon Lab Engineer
UL Korea, Ltd.

2. TEST METHODOLOGY

The tests documented in this report were performed in accordance with TIA-603-D, FCC CFR 47 Part 2 and Part 22.

3. FACILITIES AND ACCREDITATION

The test sites and measurement facilities used to collect data are located at 218 Maeyeong-ro, Yeongtong-gu, Suwon-si, Gyeonggi-do, 16675, Korea. Line conducted emissions are measured only at the 218 address. The following table identifies which facilities were utilized for radiated emission measurements documented in this report. Specific facilities are also identified in the test results sections.

218 Maeyeong-ro	
<input type="checkbox"/>	Chamber 1
<input checked="" type="checkbox"/>	Chamber 2

UL Korea, Ltd. is accredited by IAS, Laboratory Code TL-637. The full scope of accreditation can be viewed at <http://www.iasonline.org/PDF/TL/TL-637.pdf>.

4. CALIBRATION AND UNCERTAINTY

4.1. MEASURING INSTRUMENT CALIBRATION

The measuring equipment utilized to perform the tests documented in this report has been calibrated in accordance with the manufacturer's recommendations, and is traceable to recognized national standards.

4.2. SAMPLE CALCULATION

Where relevant, the following sample calculation is provided:

EIRP = PSA reading with EUT worst orientation (dBm) + Path loss (dB) – cable loss(between the SG and substitution antenna) + Substitution Antenna Factor (dBi)

ERP = PSA reading with EUT worst orientation (dBm) + Path loss (dB) – cable loss(between the SG and substitution antenna)
 (Path loss = Signal generator output – PSA reading with substitution antenna)

4.3. MEASUREMENT UNCERTAINTY

Where relevant, the following measurement uncertainty levels have been estimated for tests performed on the apparatus:

PARAMETER	UNCERTAINTY
Conducted Disturbance, 0.15 to 30 MHz	2.32 dB
Radiated Disturbance, Below 1GHz	4.14 dB
Radiated Disturbance, Above 1 GHz	5.97 dB

Uncertainty figures are valid to a confidence level of 95%.

5. EQUIPMENT UNDER TEST

5.1. DESCRIPTION OF EUT

The EUT is a LTE Watch + Bluetooth/BLE and DTS b/g/n.

SM-R765, SM-R765S, SM-R765K and SM-R765L are same H/W, only difference is UI (App, Booting logo) for network operator. SM-R765 was used for the tests.

5.2. MAXIMUM OUTPUT POWER (LTE)

The transmitter has a maximum peak conducted and radiated ERP / EIRP output powers as follows:

LTE Band 5

FCC Part 22							
Band	Frequency Range [MHz]	BandWidth [MHz]	Modulation Peak	Conducted		Radiated	
				Avg [dBm]	Avg [mW]	Avg [dBm]	Avg [mW]
Band 5	824 ~ 849	10	QPSK	22.75	188.36	-2.12	0.61
			16QAM	20.69	117.22	-3.10	0.49
		5	QPSK	22.74	187.93	-3.48	0.45
			16QAM	20.75	118.85	-4.43	0.36
		3	QPSK	22.80	190.55	-2.33	0.58
			16QAM	20.67	116.68	-3.39	0.46
		1.4	QPSK	22.71	186.64	-4.10	0.39
			16QAM	20.61	115.08	-5.02	0.31

DESCRIPTION OF AVAILABLE ANTENNAS

The radio utilizes a FPCB antenna for the [List the bands supported with a maximum peak gain as follow:

Frequency (MHz)	Peak Gain (dBi)
LTE Band 5 824 ~ 849 MHz	-14.5

5.3. DESCRIPTION OF TEST SETUP

SUPPORT EQUIPMENT

Support Equipment List				
Description	Manufacturer	Model	Serial Number	FCC ID
Adapter	SAMSUNG	EP-TA60EBE	R37G9A2082RT3	N/A
Wireless Charger	SAMSUNG	EP-YO760	N/A	A3LEPYO760

I/O CABLES

I/O Cable List						
Cable No	Port	# of identical ports	Connector Type	Cable Type	Cable Length (m)	Remarks
1	DC Power	1	Mini-USB	Shielded	0.8m	N/A

TEST SETUP

The EUT is continuously communicated to the call box during the tests.

SETUP DIAGRAM FOR TESTS (CONDUCTED TEST SETUP)

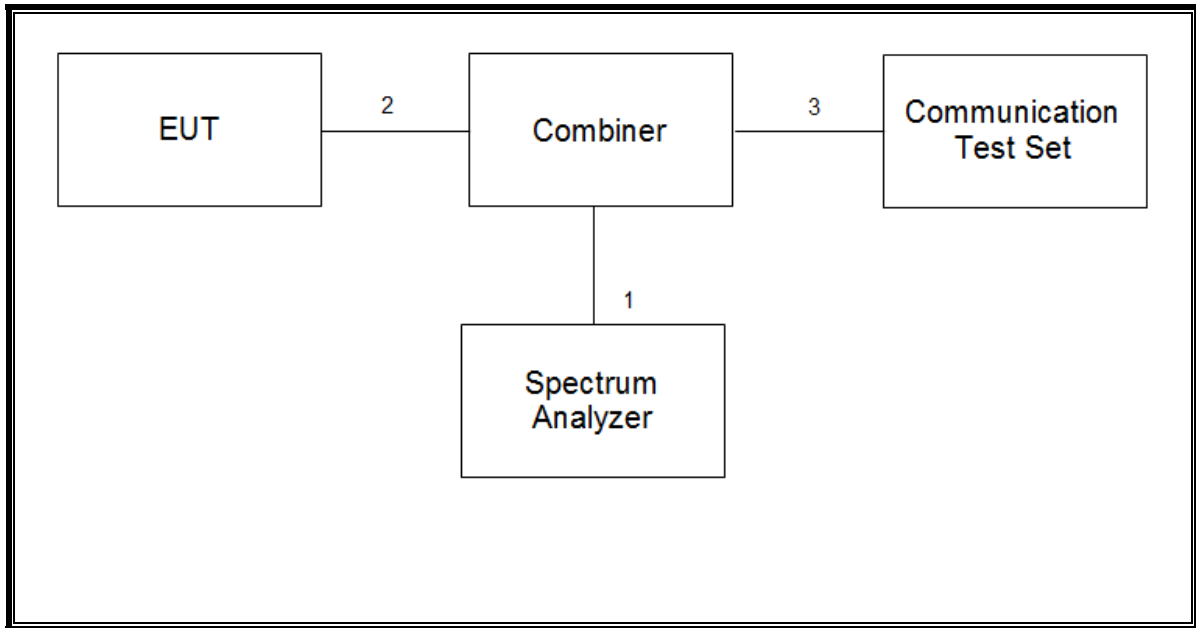

SETUP DIAGRAM FOR TESTS (RADIATED TEST SETUP)

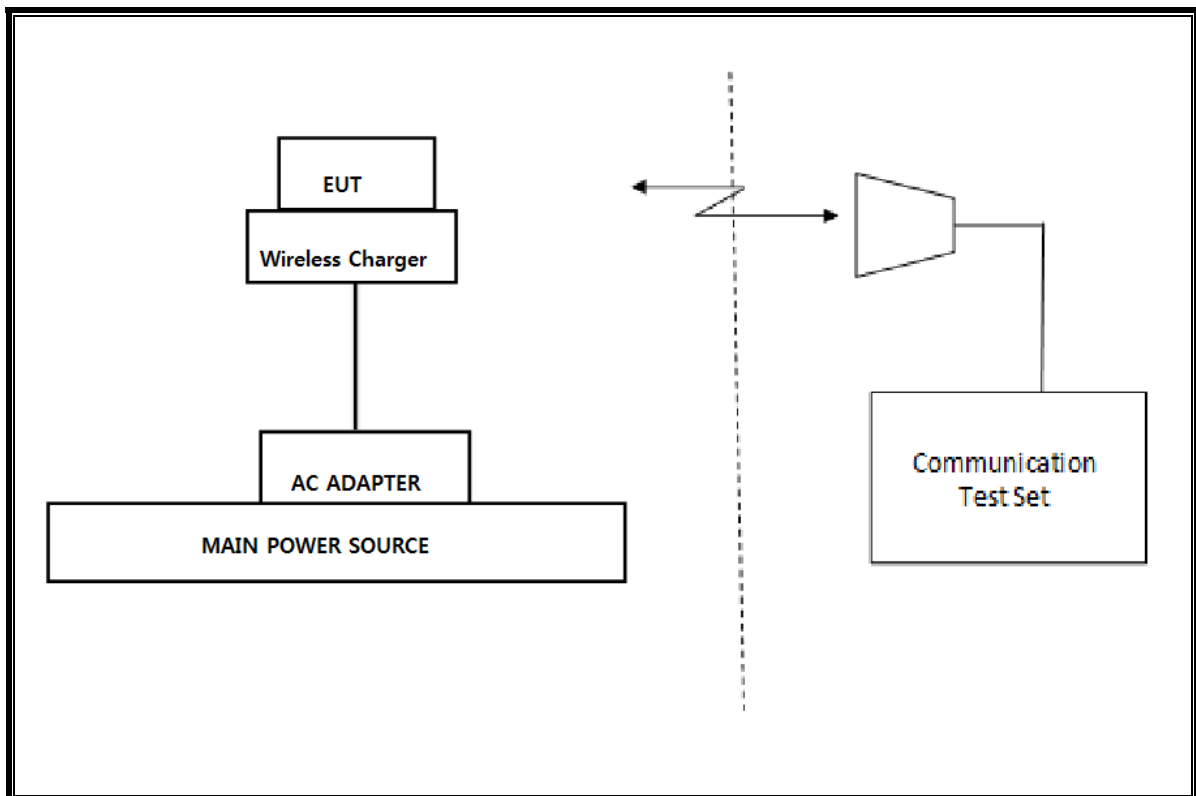

6. TEST AND MEASUREMENT EQUIPMENT

The following test and measurement equipment was utilized for the tests documented in this report:

Test Equipment List				
Description	Manufacturer	Model	S/N	Cal Due
Antenna, Tuned Dipole 400~1000 MHz	ETS	3121D DB4	00164753	07-28-17
Antenna, Horn, 40 GHz	ETS	3116C	00166155	11-30-17
Antenna, Horn, 40 GHz	ETS	3116C-PA	00168841	12-15-17
Antenna, Bilog, 30MHz-1GHz	SCHWARZBECK	VULB9163	750	11-17-16
Antenna, Bilog, 30MHz-1GHz	SCHWARZBECK	VULB9163	749	04-25-17
Antenna, Horn, 18 GHz	ETS	3115	00167211	09-20-16
Antenna, Horn, 18 GHz	ETS	3115	00161451	05-17-17
Antenna, Horn, 18 GHz	ETS	3117	00168724	06-17-17
Antenna, Horn, 18 GHz	ETS	3117	00168717	06-17-17
Combiner	WEINSCHTEL	1575	2152	08-16-17
Communications Test Set	R&S	CMW500	150312	08-17-17
Communications Test Set	R&S	CMW500	115331	08-17-17
DC Power Supply	Agilent / HP	E3640A	MY54226395	08-16-17
Preamplifier, 1000 MHz	Sonoma	310N	341282	08-17-17
Preamplifier, 1000 MHz	Sonoma	310N	351741	08-16-17
Preamplifier	ETS	3115-PA	00167475	08-17-17
Preamplifier, 18 GHz	Miteq	AFS42-00101800-25-S-42	1896138	08-16-17
Spectrum Analyzer, 44 GHz	Agilent / HP	N9030A	MY54170614	08-17-17
Spectrum Analyzer, 44 GHz	Agilent / HP	N9030A	MY54490312	08-16-17
Bluetooth Tester	TESCOM	TC-3000C	3000C000546	08-18-17
Average Power Sensor	R&S	NRZ-Z91	102681	08-16-17
Average Power Sensor	Agilent / HP	U2000	MY54270007	08-17-17
EMI Test Receive, 40 GHz	R&S	ESU40	100439	08-17-17
EMI Test Receive, 40 GHz	R&S	ESU40	100457	08-16-17
EMI Test Receive, 3 GHz	R&S	ESR3	101832	08-16-17
Attenuator / Switch driver	HP	11713A	3748A04272	N/A
High Pass Filter 1.2GHz	Micro-Tronics	HPM50108-02	G005	08-17-17
High Pass Filter 1.2GHz	Micro-Tronics	HPM50108-02	G006	08-17-17
High Pass Filter 2.8GHz	Micro-Tronics	HPM50111-02	010	08-17-17
High Pass Filter 2.8GHz	Micro-Tronics	HPM50111-02	011	08-17-17
High Pass Filter 4GHz	Micro-Tronics	HPM50118-02	G001	08-17-17
High Pass Filter 4GHz	Micro-Tronics	HPM50118-02	G002	08-17-17
LISN	R&S	ENV-216	101836	08-16-17
LISN	R&S	ENV-216	101837	08-16-17
Attenuator	PASTERNAK	PE7087-10	A009	08-16-17

7. Summary Table

FCC Part Section	Test Description	Test Limit	Test Condition	Test Result	Note
2.1049	Occupied Band width (99%)	N/A	Conducted	Pass	8.9572 MHz
22.917(a)	Band Edge / Conducted Spurious Emission	-13dBm		Pass	-15.642dBm
2.1046	Conducted output power	N/A		Pass	22.75 dBm
22.355	Frequency Stability	2.5PPM		Pass	-0.018PPM
22.913(a)(2)	Effective Radiated Power	38 dBm	Radiated	Pass	-2.12 dBm
22.917(a)	Radiated Spurious Emission	-13dBm		Pass	-52.1 dBm

FCC Rule Part	Frequency Range [MHz]	Output Power [W]	Frequency Tolerance	Emission Designator	Emission Bandwidth	Communication Type
LTE Band 5						
22H	829.0 - 844.0	0.00061	2.5 ppm	8M96G7W	10	QPSK
22H	829.0 - 844.0	0.00049	2.5 ppm	8M96D7W	10	16QAM

8. RF POWER OUTPUT VERIFICATION

8.1. LTE OUTPUT VERIFICATION

The following tests were conducted according to the test requirements outlined in section 6.2 of the 3GPP TS36.101 specification.

UE Power Class: 3 (23 +/- 2dBm). The allowed Maximum Power Reduction (MPR) for the maximum output power due to higher order modulation and transmit bandwidth configuration (resource blocks) is specified in Table 6.2.3-1 of the 3GPP TS36.101.

Table 6.2.3-1: Maximum Power Reduction (MPR) for Power Class 3

Modulation	Channel bandwidth / Transmission bandwidth (RB)						MPR (dB)
	1.4 MHz	3.0 MHz	5 MHz	10 MHz	15 MHz	20 MHz	
QPSK	> 5	> 4	> 8	> 12	> 16	> 18	≤ 1
16 QAM	≤ 5	≤ 4	≤ 8	≤ 12	≤ 16	≤ 18	≤ 1
16 QAM	> 5	> 4	> 8	> 12	> 16	> 18	≤ 2

The allowed A-MPR values specified below in Table 6.2.4.-1 of 3GPP TS36.101 are in addition to the allowed MPR requirements. All the measurements below were performed with A-MPR disabled, by using Network Signalling Value of “NS_01”.

Table 6.2.4-1: Additional Maximum Power Reduction (A-MPR)

Network Signalling value	Requirements (sub-clause)	E-UTRA Band	Channel bandwidth (MHz)	Resources Blocks (N_{RB})	A-MPR (dB)
NS_01	6.6.2.1.1	Table 5.5-1	1.4, 3, 5, 10, 15, 20	Table 5.6-1	NA
NS_03	6.6.2.2.1	2, 4, 10, 23, 25, 35, 36	3	>5	≤ 1
			5	>6	≤ 1
			10	>6	≤ 1
			15	>8	≤ 1
			20	>10	≤ 1
NS_04	6.6.2.2.2	41	5	>6	≤ 1
			10, 15, 20	See Table 6.2.4-4	
NS_05	6.6.3.3.1	1	10,15,20	≥ 50	≤ 1
NS_06	6.6.2.2.3	12, 13, 14, 17	1.4, 3, 5, 10	Table 5.6-1	n/a
NS_07	6.6.2.2.3	13	10	Table 6.2.4-2	Table 6.2.4-2
	6.6.3.3.2				
NS_08	6.6.3.3.3	19	10, 15	> 44	≤ 3
NS_09	6.6.3.3.4	21	10, 15	> 40	≤ 1
				> 55	≤ 2
NS_10		20	15, 20	Table 6.2.4-3	Table 6.2.4-3
NS_11	6.6.2.2.1	23 ¹	1.4, 3, 5, 10	Table 6.2.4-5	Table 6.2.4-5
..					
NS_32	-	-	-	-	-

Note 1: Applies to the lower block of Band 23, i.e. a carrier placed in the 2000-2010 MHz region.

8.1.1. LTE OUTPUT POWER RESULT

LTE Band 5 Measured Results

Band	BW (MHz)	Mode	RB Allocation	RB offset	Target MPR	Avg Pwr [dBm]		
						Max. Power		
						829 MHz	836.5 MHz	844 MHz
LTE Band 5	10	QPSK	1	0	0	22.75	22.70	22.72
			1	25	0	22.69	22.66	22.67
			1	49	0	22.66	22.68	22.70
			25	0	1	20.72	20.65	20.60
			25	12	1	20.68	20.64	20.58
			25	25	1	20.66	20.63	20.60
		16QAM	50	0	1	20.70	20.62	20.57
			1	0	1	20.62	20.49	20.69
			1	25	1	20.50	20.45	20.65
			1	49	1	20.51	20.44	20.68
			25	0	2	19.70	19.65	19.61
			25	12	2	19.68	19.61	19.57
			25	25	2	19.66	19.63	19.54
			50	0	2	19.68	19.60	19.54
Band	BW (MHz)	Mode	RB Allocation	RB offset	Target MPR	Avg Pwr [dBm]		
						Max. Power		
						826.5 MHz	836.5 MHz	846.5 MHz
LTE Band 5	5	QPSK	1	0	0	22.74	22.61	22.73
			1	12	0	22.69	22.59	22.71
			1	24	0	22.69	22.60	22.72
			12	0	1	20.72	20.60	20.61
			12	7	1	20.68	20.60	20.61
			12	13	1	20.67	20.59	20.61
		16QAM	25	0	1	20.71	20.61	20.62
			1	0	1	20.75	20.45	20.39
			1	12	1	20.71	20.42	20.38
			1	24	1	20.70	20.43	20.40
			12	0	2	19.62	19.50	19.54
			12	7	2	19.63	19.47	19.55
			12	13	2	19.64	19.46	19.45
			25	0	2	19.66	19.64	19.58
Band	BW (MHz)	Mode	RB Allocation	RB offset	Target MPR	Avg Pwr [dBm]		
						Max. Power		
						825.5 MHz	836.5 MHz	847.5 MHz
LTE Band 5	3	QPSK	1	0	0	22.80	22.65	22.62
			1	8	0	22.75	22.63	22.62
			1	14	0	22.73	22.66	22.62
			8	0	1	20.68	20.57	20.57
			8	4	1	20.64	20.56	20.55
			8	7	1	20.67	20.55	20.57
		16QAM	15	0	1	20.67	20.52	20.57
			1	0	1	20.56	20.45	20.51
			1	8	1	20.60	20.44	20.64
			1	14	1	20.67	20.59	20.58
			8	0	2	19.69	19.50	19.43
			8	4	2	19.66	19.50	19.40
			8	7	2	19.69	19.49	19.38
			15	0	2	19.65	19.46	19.52
Band	BW (MHz)	Mode	RB Allocation	RB offset	Target MPR	Avg Pwr [dBm]		
						Max. Power		
						824.7 MHz	836.5 MHz	848.3 MHz
LTE Band 5	1.4	QPSK	1	0	0	22.71	22.57	22.56
			1	3	0	22.71	22.58	22.57
			1	5	0	22.70	22.54	22.60
			3	0	0	22.66	22.53	22.55
			3	1	0	22.67	22.55	22.56
			3	3	0	22.65	22.56	22.56
		16QAM	6	0	1	20.64	20.57	20.53
			1	0	1	20.33	20.50	20.35
			1	3	1	20.41	20.51	20.45
			1	5	1	20.32	20.47	20.38
			3	0	1	20.60	20.51	20.53
			3	1	1	20.61	20.53	20.54
			3	3	1	20.61	20.53	20.56
			6	0	2	19.66	19.41	19.53

9. PEAK TO AVERAGE RATIO

Test Procedure

Per KDB 971168 D01 Power Meas License Digital Systems v02r02;

The transmitter output was connected to a CMW500 Test Set and configured to operate at maximum power. The PAR were measured on the Spectrum Analyzer.

Test Spec

In addition, when the transmitter power is measured in terms of average value, the peak-to-average ratio of the power shall not exceed 13 dB.

9.1. CONDUCTED PEAK TO AVERAGE RESULT

LTE Band 5

Band	BW [MHz]	Channel	f [MHz]	Mode	Ratio [dB]	Limit [dB]
Band 5	10	20525	836.5	QPSK	3.65	13.00
				16QAM	5.56	
	5			QPSK	3.70	
				16QAM	5.36	
	3			QPSK	3.71	
				16QAM	5.65	
	1.4			QPSK	3.72	
				16QAM	5.54	

9.2. CONDUCTED PEAK TO AVERAGE PLOTS

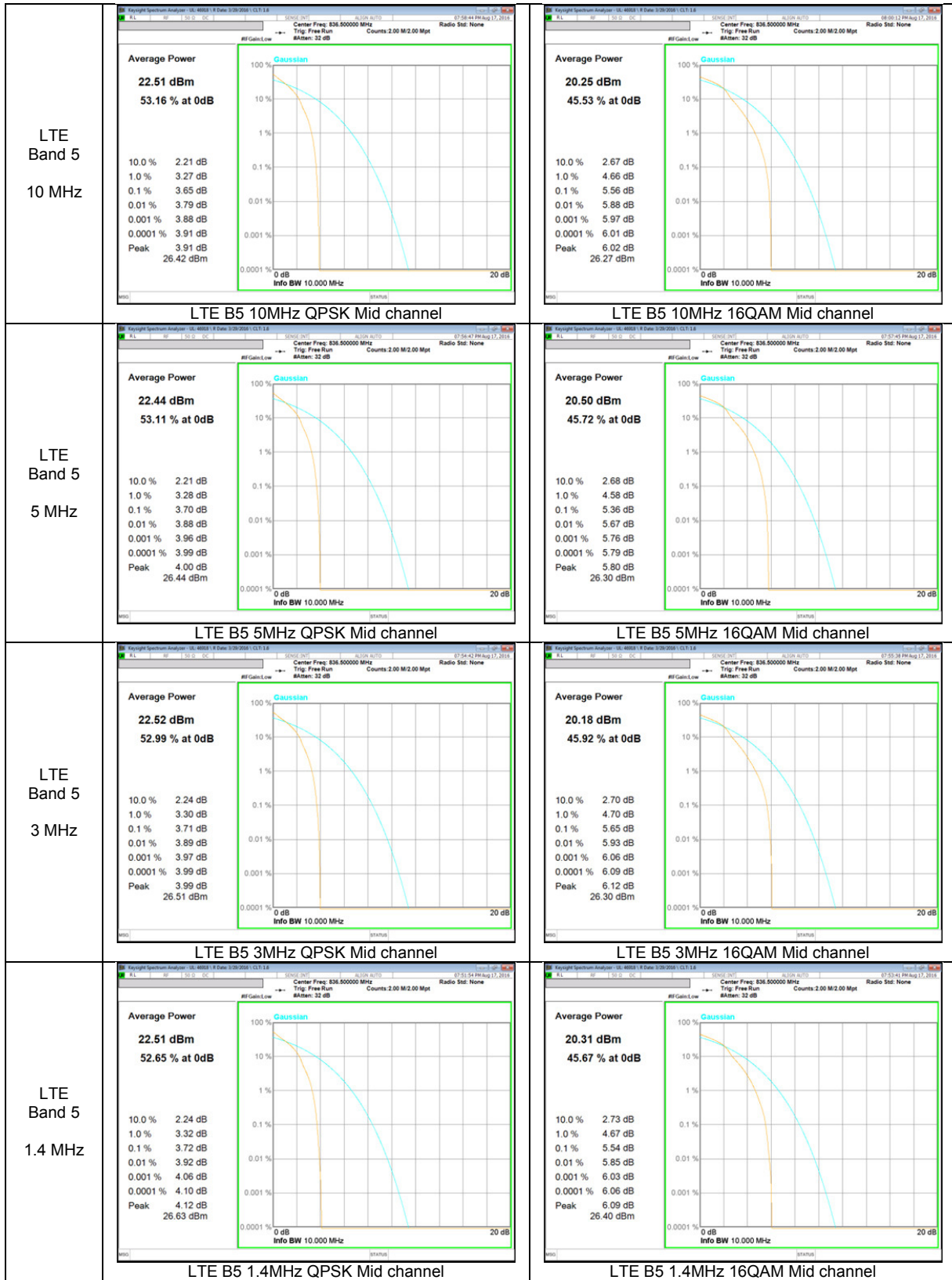

10. LIMITS AND CONDUCTED RESULTS

10.1. OCCUPIED BANDWIDTH

RULE PART(S)

FCC: §2.1049

LIMITS

For reporting purposes only

TEST PROCEDURE

The transmitter output was connected to a calibrated coaxial cable and coupler, the other end of which was connected to a spectrum analyzer. The occupied bandwidth was measured with the spectrum analyzer at the low, middle and high channel in each band. The -26dB bandwidth was also measured and recorded.

(KDB 971168 D01 Power Meas License Digital Systems v02r02)

LTE Band 5

Band	BW [MHz]	Channel	f [MHz]	Mode	99% BW [MHz]	26dB BW [MHz]
Band 5	10	20450	829.0	QPSK	8.9278	10.14
				16QAM	8.9226	9.990
		20524	836.5	QPSK	8.9499	10.16
				16QAM	8.9512	10.18
		20599	844.0	QPSK	8.9572	10.21
				16QAM	8.9564	10.21
	5	20425	826.5	QPSK	4.5035	5.182
				16QAM	4.5113	5.327
		20524	836.5	QPSK	4.5008	5.299
				16QAM	4.5083	5.222
		20624	846.5	QPSK	4.4993	5.218
				16QAM	4.5006	5.345
	3	20415	825.5	QPSK	2.6916	3.062
				16QAM	2.7010	3.084
		20524	836.5	QPSK	2.7208	3.120
				16QAM	2.6992	3.076
		20634	847.5	QPSK	2.7020	3.079
				16QAM	2.6965	3.108
	1.4	20407	824.7	QPSK	1.0907	1.367
				16QAM	1.0905	1.370
		20524	836.5	QPSK	1.0910	1.411
				16QAM	1.0909	1.343
		20624	848.3	QPSK	1.0927	1.373
				16QAM	1.0916	1.408

10.1.1. OCCUPIED BANDWIDTH PLOTS
LTE Band 5

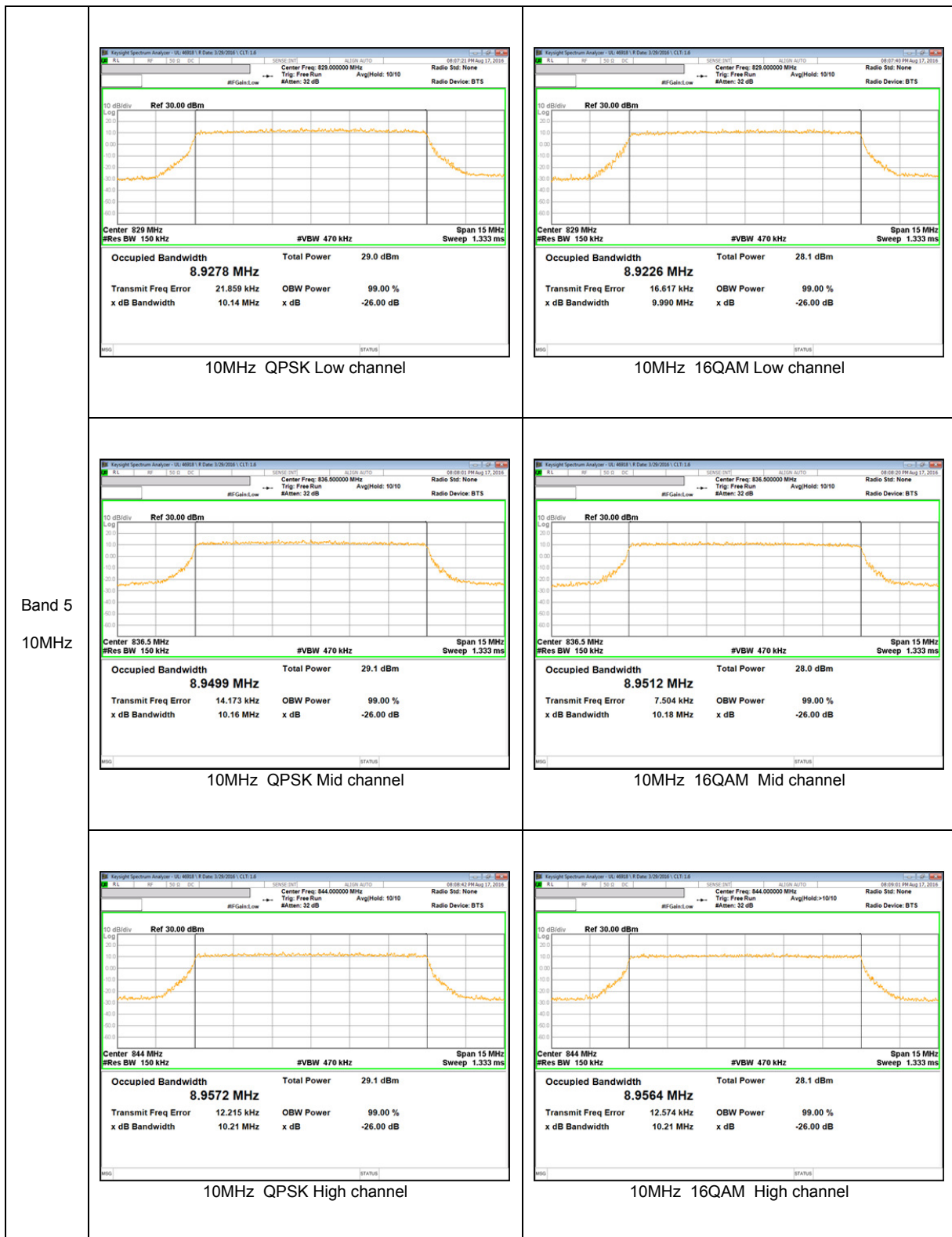

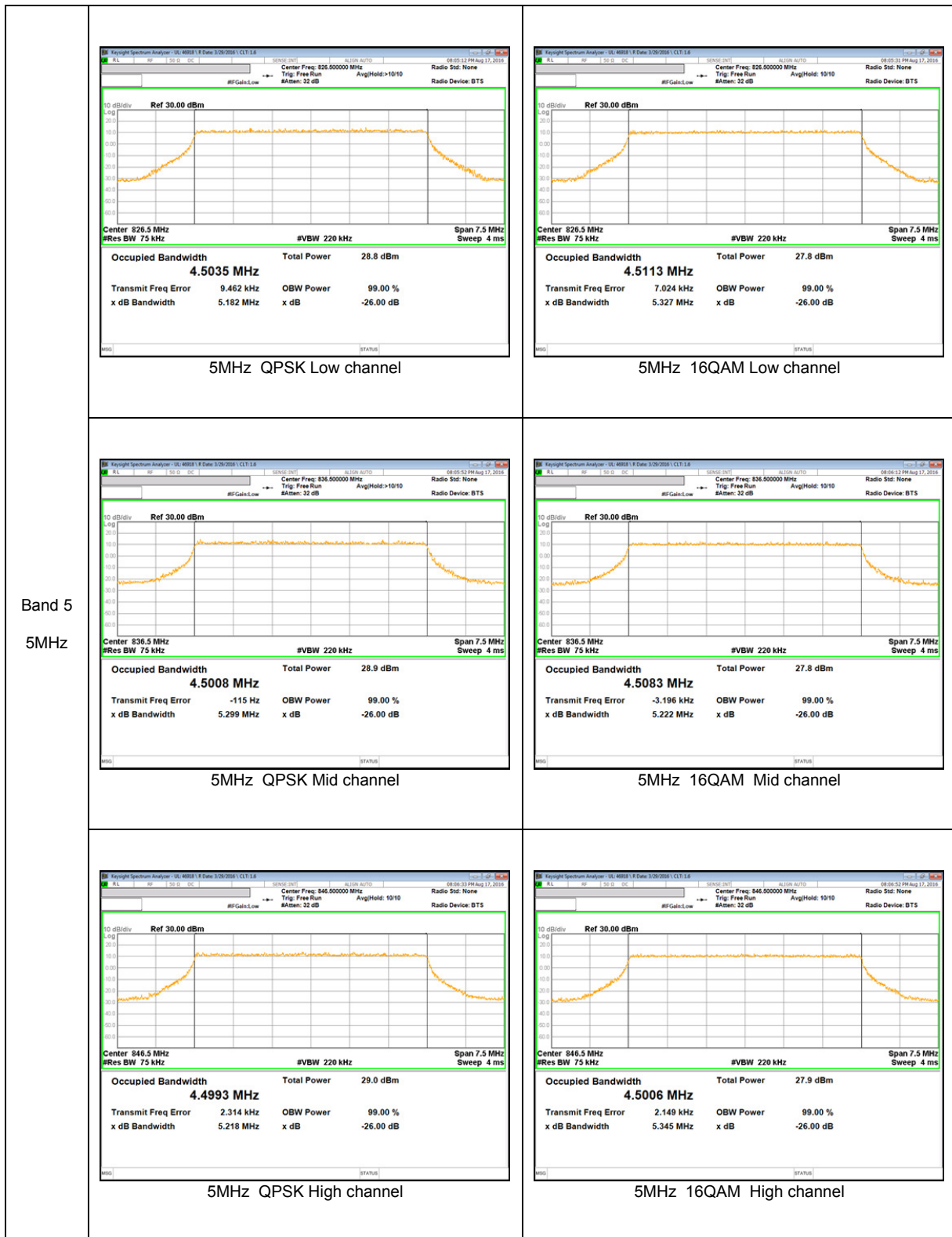



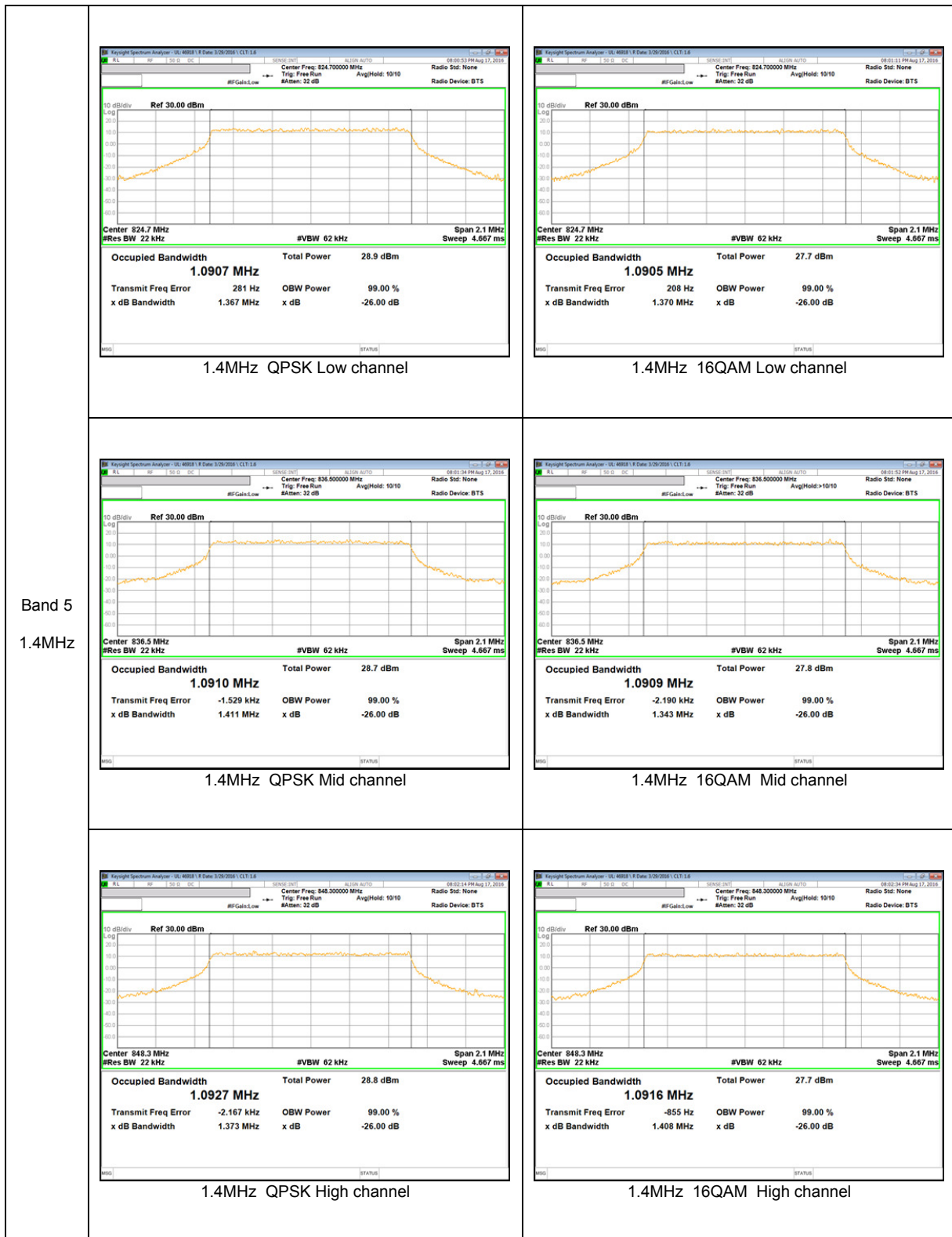

10.2. BAND EDGE EMISSIONS

RULE PART(S)

FCC: §22.359

LIMITS

The power of any emission outside of the authorized operating frequency ranges must be attenuated below the transmitting power (P) by a factor of at least $43 + 10 \log (P)$ dB.

TEST PROCEDURE

Per KDB 971168 D01 Power Meas License Digital Systems v02r02

The transmitter output was connected to a CMW500 Test Set and configured to operate at maximum power. The band edge emissions were measured at the required operating frequencies in each band on the Spectrum Analyzer.

RESULTS

LTE 5

Bandwidth	Mode	Side	RB Status	f [MHz]	Level [dBm]	Limit [dBm]
10 MHz	QPSK	Lower	1RB	824.000	-34.713	-13.00
			FRB	824.000	-27.236	
		Upper	1RB	849.000	-26.107	
			FRB	849.000	-28.291	
	16QAM	Lower	1RB	824.000	-35.186	
			FRB	824.000	-31.538	
		Upper	1RB	849.000	-28.025	
			FRB	849.000	-31.340	
5 MHz	QPSK	Lower	1RB	824.000	-20.552	
			FRB	824.000	-25.719	
		Upper	1RB	849.000	-18.501	
			FRB	849.000	-25.056	
	16QAM	Lower	1RB	824.000	-24.989	
			FRB	824.000	-24.778	
		Upper	1RB	849.000	-24.086	
			FRB	849.000	-27.199	
3 MHz	QPSK	Lower	1RB	824.000	-20.394	
			FRB	824.000	-23.854	
		Upper	1RB	849.000	-15.642	
			FRB	849.000	-24.077	
	16QAM	Lower	1RB	824.000	-22.167	
			FRB	824.000	-28.492	
		Upper	1RB	849.000	-20.371	
			FRB	849.000	-23.515	
1.4 MHz	QPSK	Lower	1RB	824.000	-25.460	
			FRB	824.000	-25.298	
		Upper	1RB	849.000	-22.545	
			FRB	849.000	-23.973	
	16QAM	Lower	1RB	824.000	-26.561	
			FRB	824.000	-24.759	
		Upper	1RB	849.000	-26.107	
			FRB	849.000	-25.052	

10.2.1. BAND EDGE PLOTS

LTE Band 5

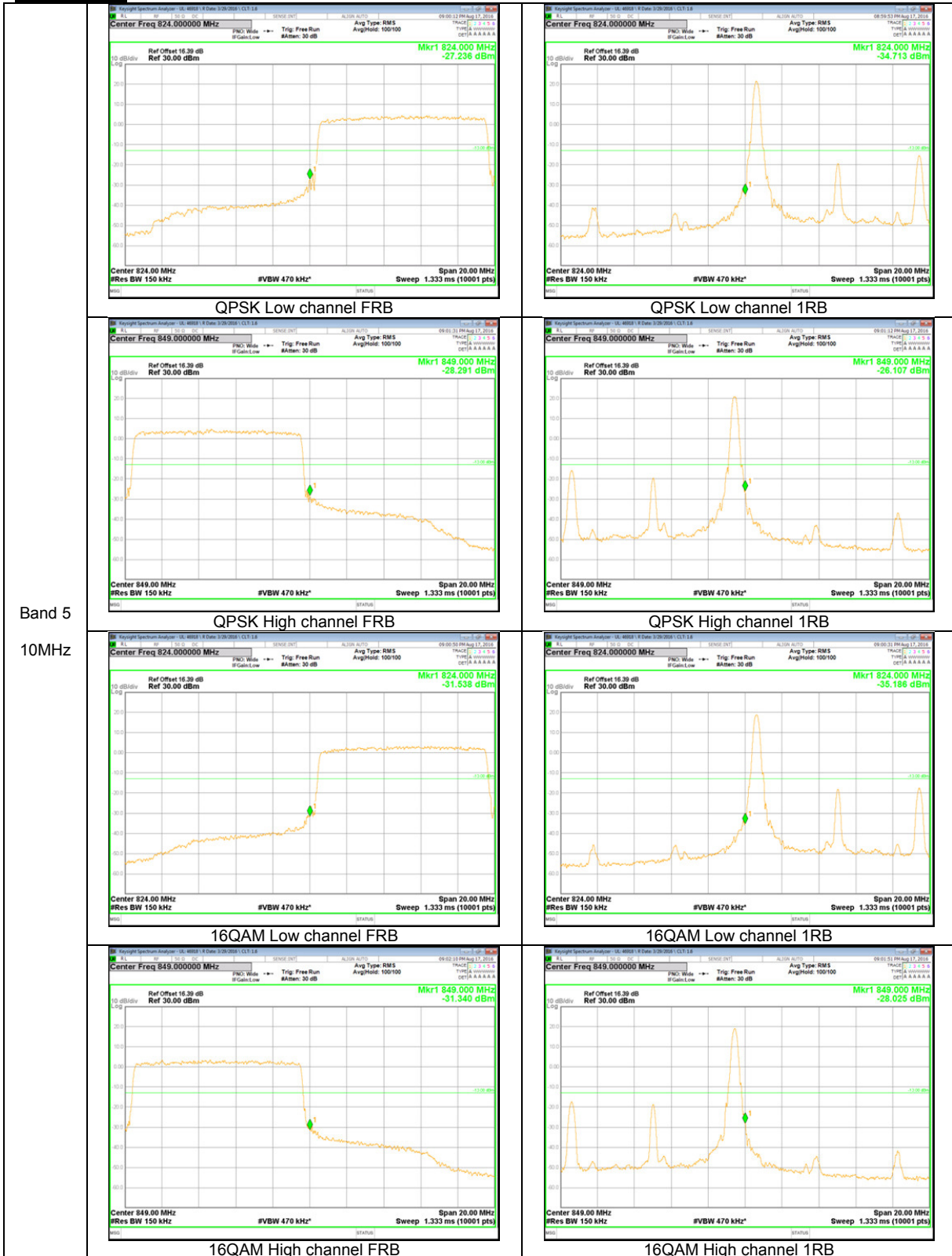

Band 5
10MHz

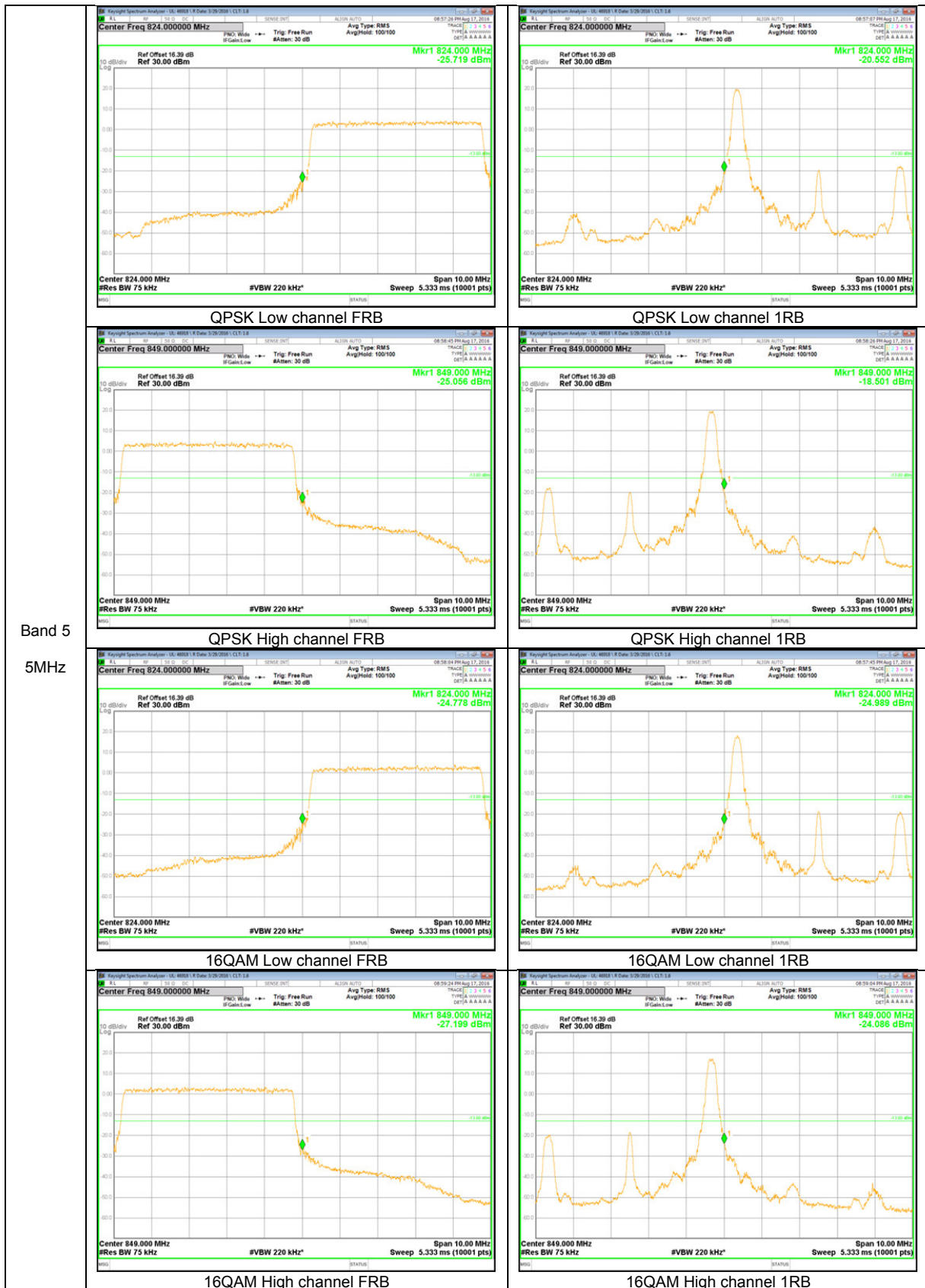

Band 5
 5MHz

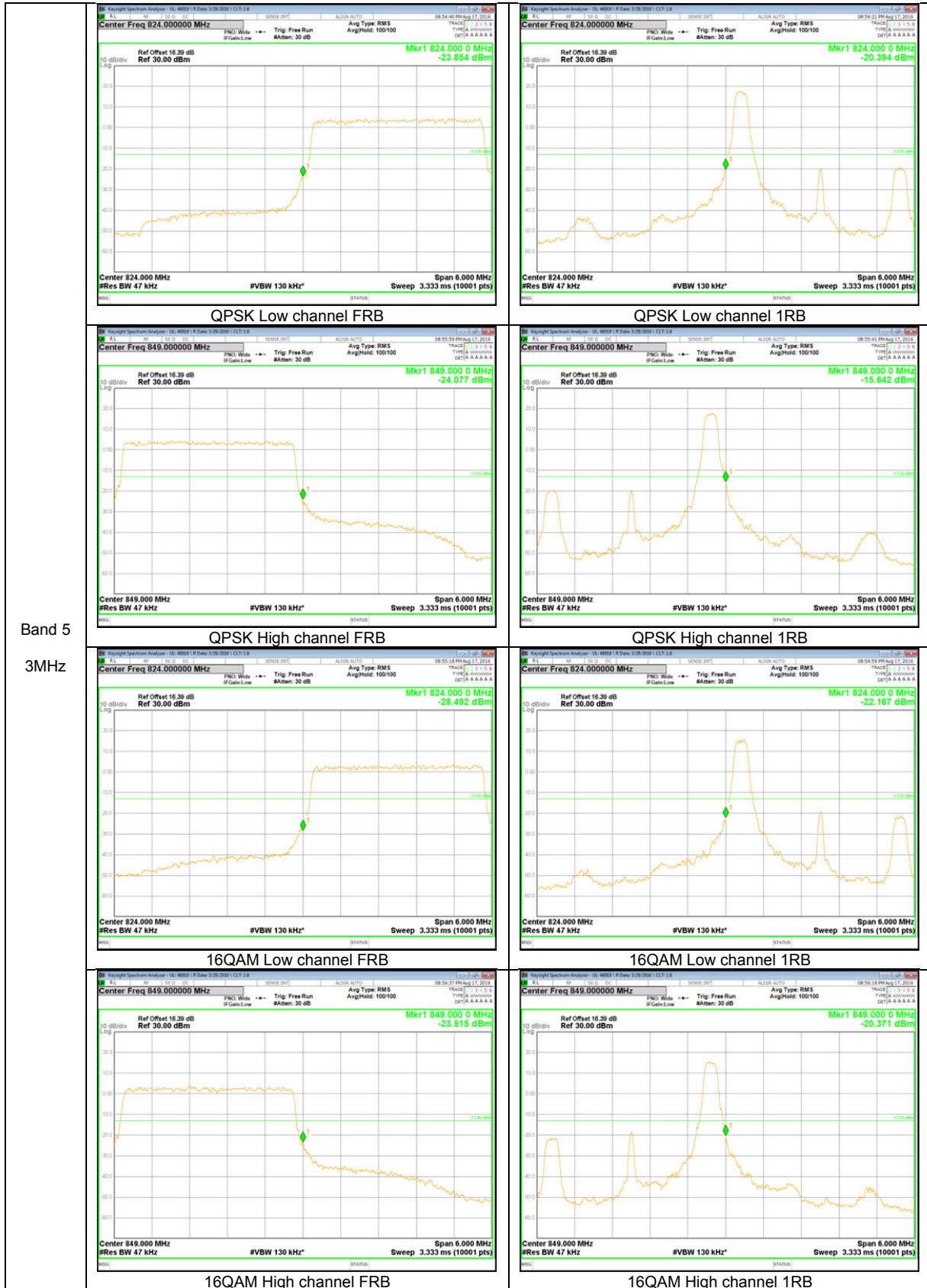

Band 5
3MHz

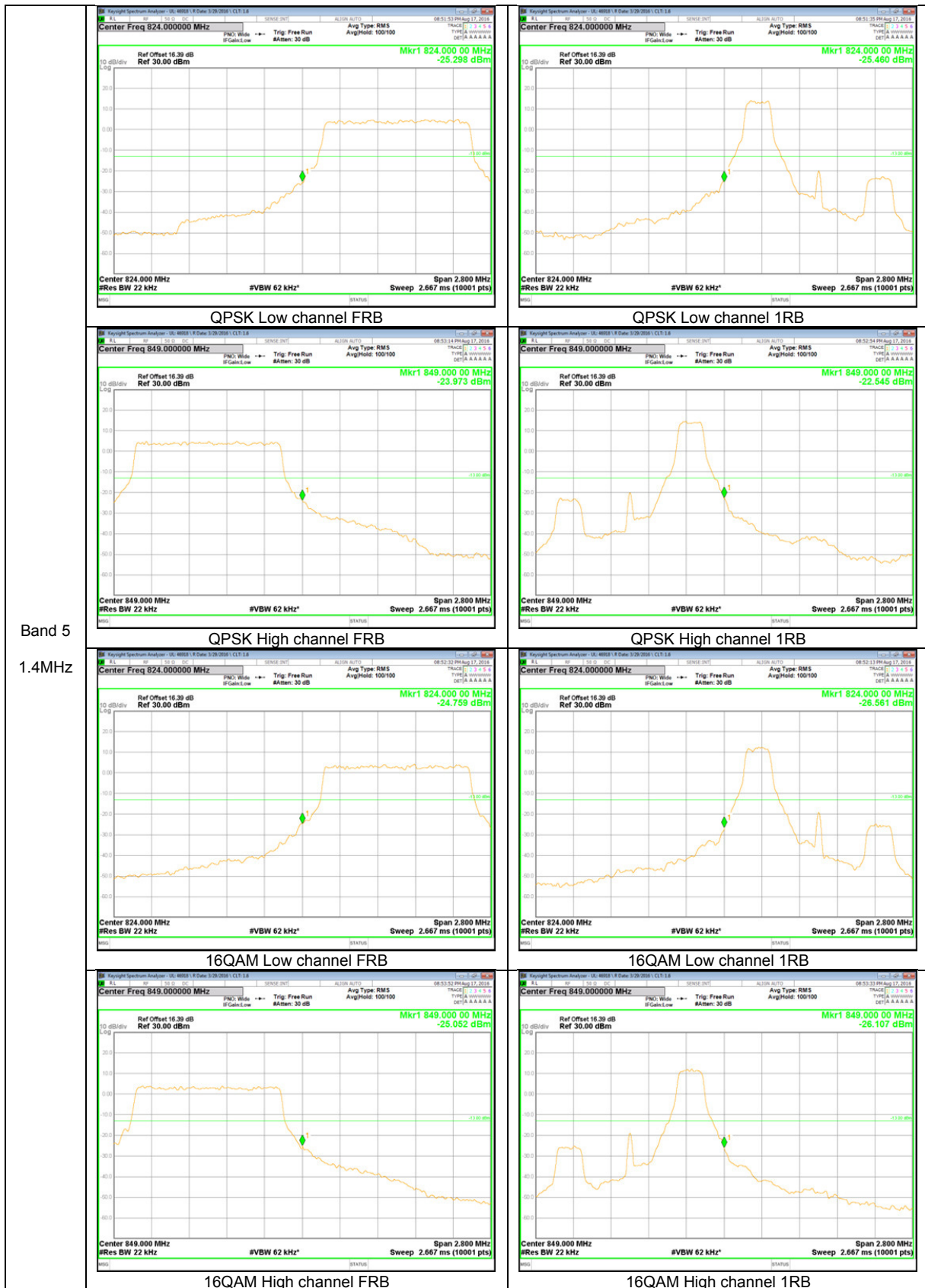

Band 5
 1.4MHz

10.3. OUT OF BAND EMISSIONS

RULE PART(S)

FCC: §2.1051, §22.901, §22.917

LIMITS

The power of any emission outside of the authorized operating frequency ranges must be attenuated below the transmitting power (P) by a factor of at least $43 + 10 \log (P)$ dB.

TEST PROCEDURE

Per KDB 971168 D01 Power Meas License Digital Systems v02r02

The RF output of the transmitter was connected to a spectrum analyzer through a calibrated coaxial cable. Sufficient scans were taken to show the out-of-band Emissions, if any, up to 10th harmonic. Multiple sweeps were recorded in maximum hold mode using a peak detector to ensure that the worst-case emissions were caught.

RESULTS

10.3.1. OUT OF BAND EMISSIONS RESULT

LTE 5

Bandwidth	Mode	f [MHz]	Spurious [dBm]	Limit [dBm]
10 MHz	QPSK	829.0	-26.56	-13.00
		836.5	-27.25	
		844.0	-26.84	
	16QAM	829.0	-27.54	
		836.5	-28.08	
		844.0	-27.39	
5 MHz	QPSK	826.5	-27.56	
		836.5	-25.86	
		846.5	-27.50	
	16QAM	826.5	-26.90	
		836.5	-28.03	
		846.5	-26.77	
3 MHz	QPSK	825.5	-27.69	
		836.5	-26.22	
		847.5	-26.65	
	16QAM	825.5	-27.23	
		836.5	-27.05	
		847.5	-25.63	
1.4 MHz	QPSK	824.7	-27.23	
		836.5	-27.69	
		848.3	-27.35	
	16QAM	824.7	-27.87	
		836.5	-27.57	
		848.3	-27.10	

10.3.2. OUT OF BAND EMISSIONS PLOTS
LTE Band 5

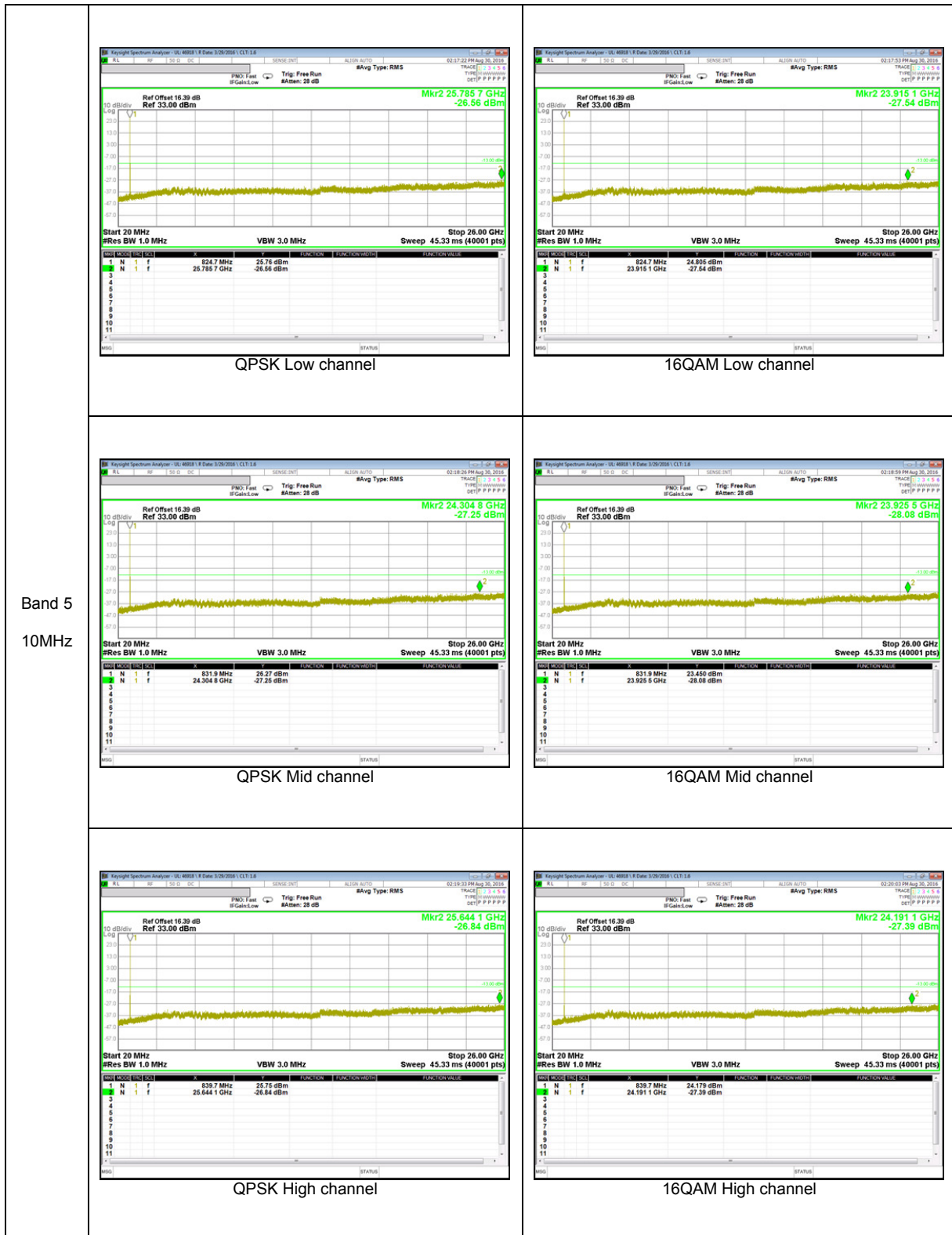

Band 5
 10MHz

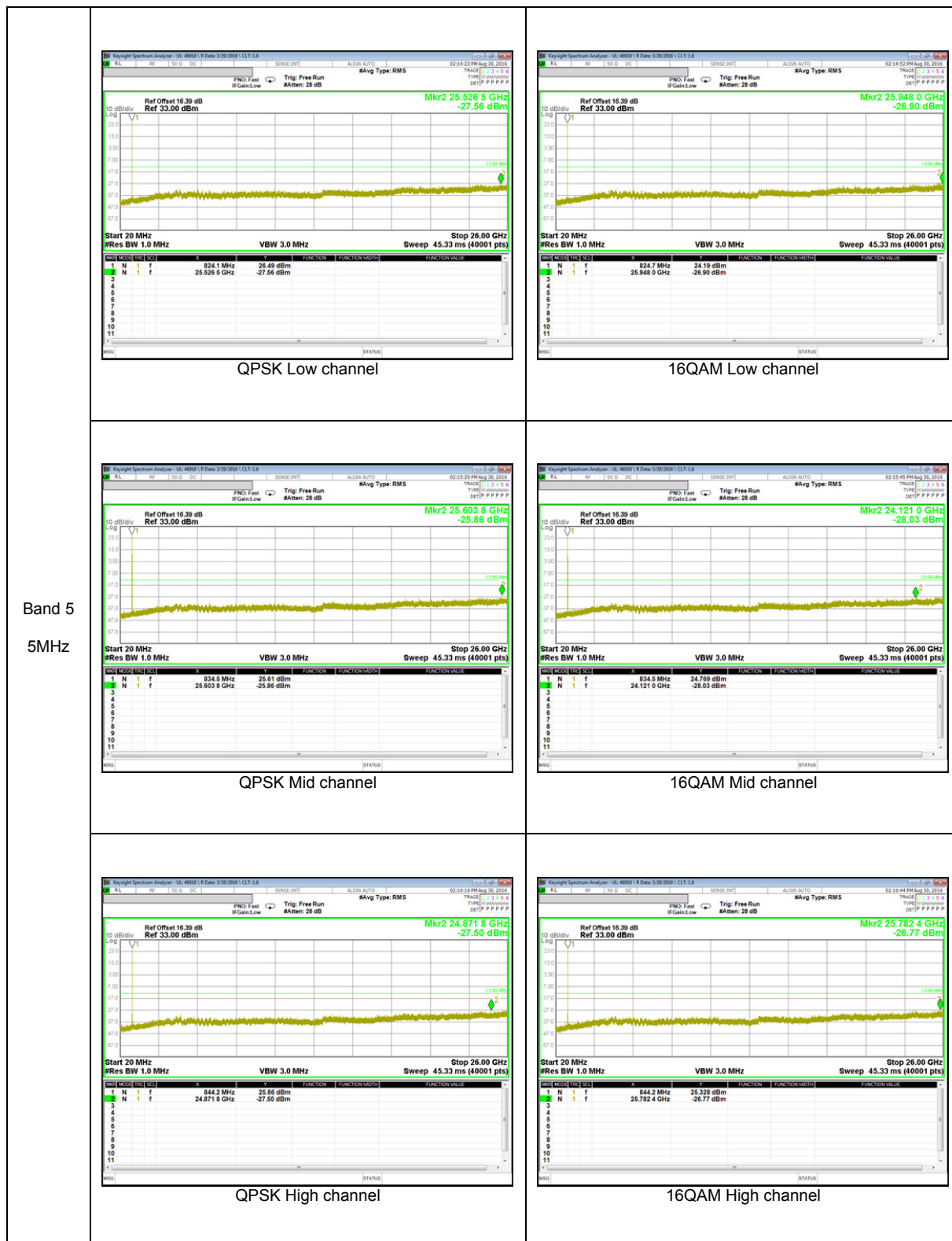

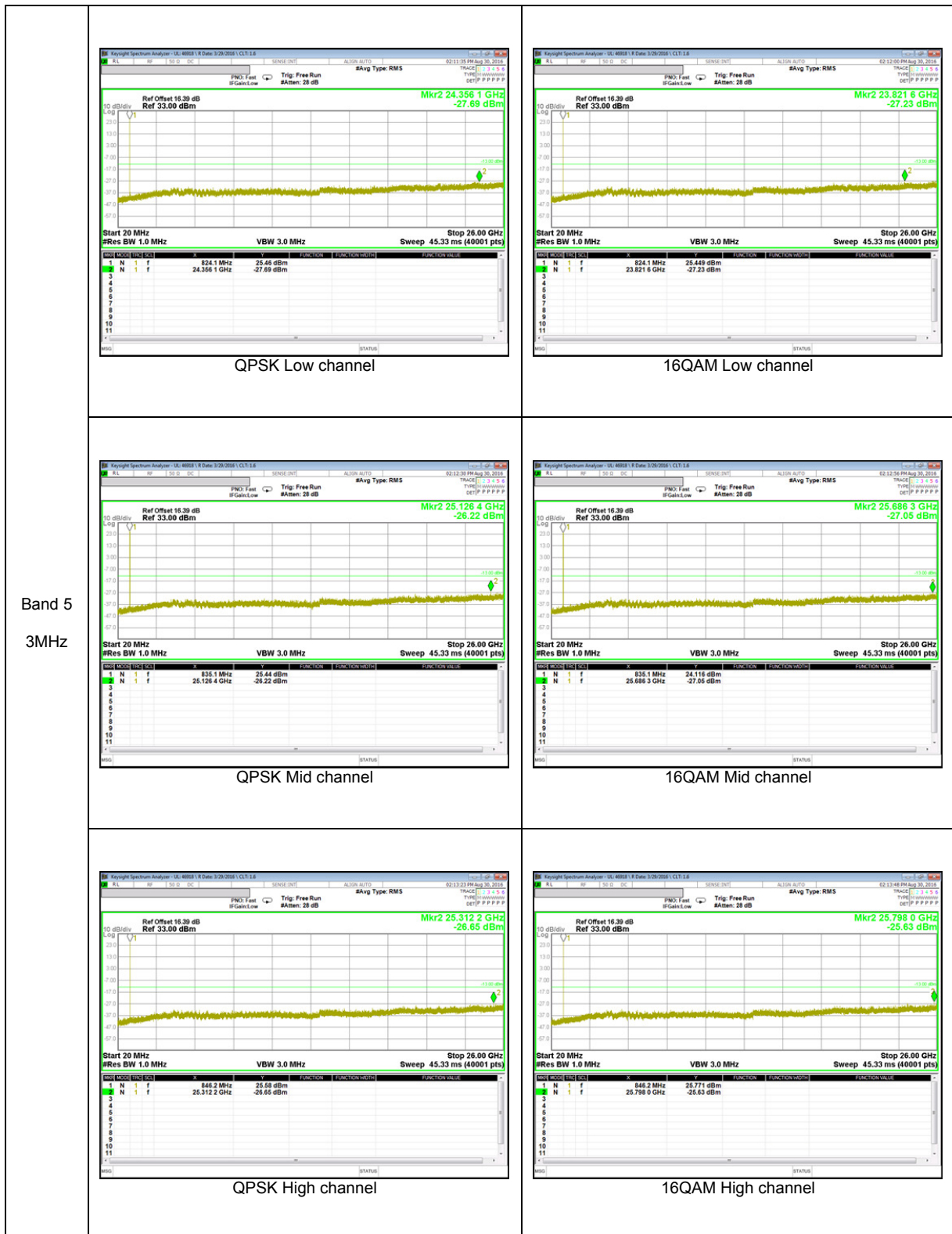

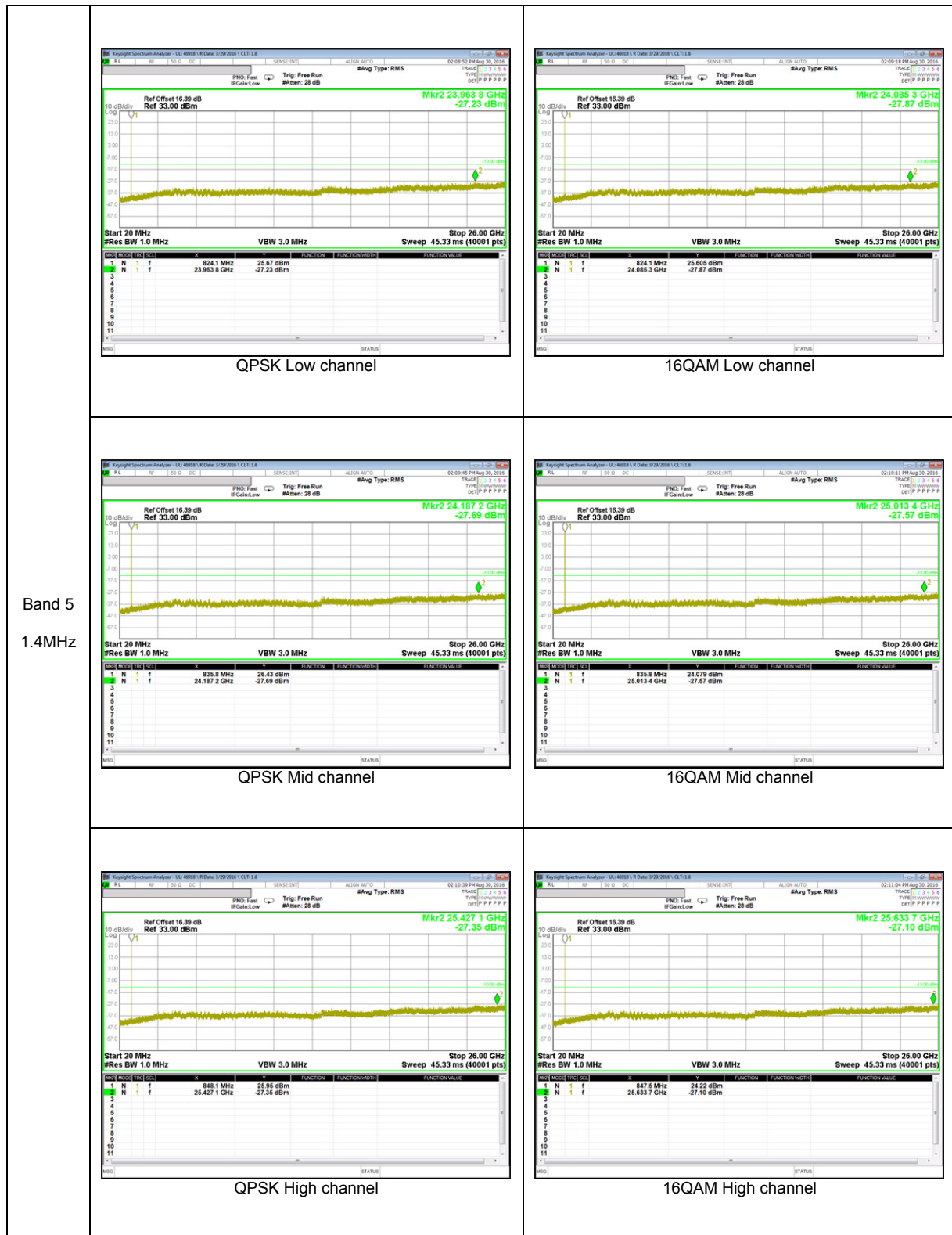

10.4. FREQUENCY STABILITY

RULE PART(S)

FCC: §2.1055, §22.355

LIMITS

§22.355 - The carrier frequency shall not depart from the reference frequency in excess of ± 2.5 ppm for mobile stations.

TEST PROCEDURE

Per KDB 971168 D01 Power Meas License Digital Systems v02r02

RESULTS

See the following pages.

10.4.1. FREQUENCY STABILITY RESULTS

LTE Band 5, Channel 20524, Frequency 836.5 MHz

Reference Frequency: LTE Band 5 Mid Channel 836.5 MHz @ 20°C				
Limit: +/- 2.5 ppm = 2091.250 Hz				
Power Supply [Vdc]	Environment Temperature [°C]	Frequency Deviation Measured with Time Elapse		
		[MHz]	Delta [ppm]	Limit [ppm]
3.85	50	836.49998215	0.003	2.5
3.85	40	836.49998442	0.001	2.5
3.85	30	836.49998792	-0.003	2.5
3.85	20	836.49998506	0	2.5
3.85	10	836.49998444	0.001	2.5
3.85	0	836.49998545	0.000	2.5
3.85	-10	836.49998279	0.003	2.5
3.85	-20	836.49998457	0.001	2.5
3.85	-30	836.50000000	-0.018	2.5

Reference Frequency: LTE Band 5 Mid Channel 836.5 MHz @ 20°C				
Limit: +/- 2.5 ppm = 2091.250 Hz				
Power Supply [Vdc]	Environment Temperature [°C]	Frequency Deviation Measured with Time Elapse		
		[MHz]	Delta [ppm]	Limit [ppm]
3.85	20	836.49998506	0	2.5
4.20	20	836.49998358	0.002	2.5
3.60	20	836.49998116	0.005	2.5

11. RADIATED TEST RESULTS

11.1. RADIATED POWER (ERP & EIRP)

RULE PART(S)

FCC: §2.1046, §22.913

LIMITS

22.913(a) - The ERP of mobile transmitters and auxiliary test transmitters must not exceed 7 Watts.

In addition, when the transmitter power is measured in terms of average value, the peak-to-average ratio of the power shall not exceed 13dB.

TEST PROCEDURE

ANSI / TIA / EIA 603D Clause 2.2.17; MXA setting reference to 971168 D01 v02r02

For peak power measurement with a MXA:

a) Set the RBW \geq OBW; b) Set VBW $\geq 3 \times$ RBW; c) Set span $\geq 2 \times$ RBW; d) Sweep time = auto couple; e) Detector = peak; f) Ensure that the number of measurement points \geq span/RBW; g) Trace mode = max hold;

For average power measurement with a MXA:

a) Set span to at least 1.5 times the OBW; b) Set RBW = 1-5% of the OBW, not to exceed 1 MHz; c) Set VBW $\geq 3 \times$ RBW; d) Set number of points in sweep $\geq 2 \times$ span / RBW; e) Sweep time = auto-couple; f) Detector = RMS (power averaging); g) Use free run trigger If burst duty cycle ≥ 98 ; h) Use trigger to capture bursts If burst duty cycle < 98 ; i) Trace average at least 100 traces in power averaging (*i.e.*, RMS) mode. j) Compute the power by integrating the spectrum across the OBW of the signal using the instrument's band power measurement function.

TEST RESULTS

11.1.1. ERP/EIRP Results

LTE Band 5

Band	BW [MHz]	Mode	RB/RB Size	f [MHz]	ERP / EIRP	
			Full RB		[dBm]	[mW]
Band 5	10	QPSK	50/0	829.0	-2.12	0.61
			50/0	836.5	-3.34	0.46
			50/0	844.0	-4.86	0.33
		16QAM	50/0	829.0	-3.10	0.49
			50/0	836.5	-4.32	0.37
			50/0	844.0	-5.92	0.26
	5	QPSK	25/0	826.5	-3.48	0.45
			25/0	836.5	-3.50	0.45
			25/0	846.5	-5.44	0.29
		16QAM	25/0	826.5	-4.43	0.36
			25/0	836.5	-4.45	0.36
			25/0	846.5	-5.95	0.25
	3	QPSK	15/0	825.5	-2.33	0.58
			15/0	836.5	-3.49	0.45
			15/0	847.5	-5.43	0.29
		16QAM	15/0	825.5	-3.39	0.46
			15/0	836.5	-4.57	0.35
			15/0	847.5	-5.95	0.25
	1.4	QPSK	6/0	824.7	-4.10	0.39
			6/0	836.5	-5.81	0.26
			6/0	848.3	-7.17	0.19
16QAM		6/0	824.7	-5.02	0.31	
		6/0	836.5	-6.80	0.21	
		6/0	848.3	-7.60	0.17	