



**FCC CFR47 PART 22 SUBPART H
FCC CFR47 PART 24 SUBPART E**

CDMA

CERTIFICATION TEST REPORT

FOR

CDMA Watch + Bluetooth/BLE and DTS b/g/n

MODEL NUMBER : SM-R735V

FCC ID: A3LSMR735C

REPORT NUMBER: 16K22865-E4V2

ISSUE DATE: FEB 29, 2016

Prepared for
**SAMSUNG ELECTRONICS CO., LTD.
129 SAMSUNG-RO, YEONGTONG-GU, SUWON-SI,
GYEONGGI-DO, 16677, KOREA**

Prepared by
**UL Korea, Ltd. Suwon Laboratory
218 Maeyeong-ro, Yeongtong-gu,
Suwon-si, Gyeonggi-do, 16675, Korea
TEL: (031) 337-9902
FAX: (031) 213-5433**



Revision History

<u>Rev.</u>	<u>Issue Date</u>	<u>Revisions</u>	<u>Revised By</u>
V1	02/22/16	Initial issue	Junwhan Lee
V2	02/29/16	Revised test setup photo (portable)	Junwhan Lee

TABLE OF CONTENTS

1. ATTESTATION OF TEST RESULTS	5
2. TEST METHODOLOGY	6
3. FACILITIES AND ACCREDITATION	6
4. CALIBRATION AND UNCERTAINTY	6
4.1. MEASURING INSTRUMENT CALIBRATION.....	6
4.2. SAMPLE CALCULATION.....	6
4.3. MEASUREMENT UNCERTAINTY.....	6
5. EQUIPMENT UNDER TEST	7
5.1. DESCRIPTION OF EUT.....	7
5.2. MAXIMUM OUTPUT POWER.....	7
5.3. DESCRIPTION OF TEST SETUP.....	8
6. TEST AND MEASUREMENT EQUIPMENT	10
7. Summary Table	11
8. RF POWER OUTPUT VERIFICATION	12
8.1. 1xRTT.....	12
8.1.1. 1xRTT OUTPUT POWER RESULT.....	13
8.2. 1xEV-DO Release 0.....	14
8.2.1. 1xEVDO REL.0 OUTPUT POWER RESULT.....	15
8.3. 1xEV-DO Rev. A.....	16
8.3.1. 1xEVDO REL.A OUTPUT POWER RESULT.....	17
9. PEAK TO AVERAGE RATIO	18
9.1. CONDUCTED PEAK TO AVERAGE RESULT.....	18
9.2. CONDUCTED PEAK TO AVERAGE PLOTS.....	19
10. LIMITS AND CONDUCTED RESULTS	20
10.1. OCCUPIED BANDWIDTH.....	20
10.1.1. OCCUPIED BANDWIDTH RESULTS.....	20
10.1.2. OCCUPIED BANDWIDTH PLOTS.....	21
10.2. BAND EDGE EMISSIONS.....	23
10.2.1. BAND EDGE PLOTS.....	24
10.3. OUT OF BAND EMISSIONS.....	25
10.3.1. OUT OF BAND EMISSIONS RESULT.....	26
10.3.2. OUT OF BAND EMISSIONS PLOTS.....	27
10.4. FREQUENCY STABILITY.....	29

10.4.1.	FREQUENCY STABILITY RESULTS.....	30
11.	RADIATED TEST RESULTS	32
11.1.	<i>RADIATED POWER (ERP & EIRP).....</i>	<i>32</i>
11.1.1.	ERP/EIRP Results	33
11.1.2.	ERP/EIRP DATA.....	34
11.2.	<i>FIELD STRENGTH OF SPURIOUS RADIATION</i>	<i>36</i>
11.2.1.	SPURIOUS RADIATION PLOTS.....	37
12.	SETUP PHOTOS.....	39

1. ATTESTATION OF TEST RESULTS

COMPANY NAME: SAMSUNG ELECTRONICS CO., LTD.
EUT DESCRIPTION: CDMA Watch + Bluetooth/BLE and DTS b/g/n
MODEL NUMBER: SM-R735C
SERIAL NUMBER: A0000047485158, A0000047485152 (RADIATED);
A0000047485157 (CONDUCTED)
DATE TESTED: FEB 17, 2016 - FEB 19, 2016

APPLICABLE STANDARDS	
STANDARD	TEST RESULTS
FCC PART 22H, 24E	Pass

UL Korea, Ltd. tested the above equipment in accordance with the requirements set forth in the above standards. All indications of Pass/Fail in this report are opinions expressed by UL Korea, Ltd. based on interpretations and/or observations of test results. Measurement Uncertainties were not taken into account and are published for informational purposes only. The test results show that the equipment tested is capable of demonstrating compliance with the requirements as documented in this report.

Note: The results documented in this report apply only to the tested sample, under the conditions and modes of operation as described herein. This document may not be altered or revised in any way unless done so by UL Korea, Ltd. and all revisions are duly noted in the revisions section. Any alteration of this document not carried out by UL Korea, Ltd. will constitute fraud and shall nullify the document. This report must not be used by the client to claim product certification, approval, or endorsement by IAS, any agency of the Federal Government, or any agency of any government.

Approved & Released For
UL Korea, Ltd. By:



CY Choi
Suwon Lab Engineer
UL Korea, Ltd.

Tested By:



Junwhan Lee
Suwon Lab Engineer
UL Korea, Ltd.

2. TEST METHODOLOGY

The tests documented in this report were performed in accordance with TIA-603-D, FCC CFR 47 Part 22 and FCC CFR Part 24.

3. FACILITIES AND ACCREDITATION

The test sites and measurement facilities used to collect data are located at 218 Maeyeong-ro, Yeongtong-gu, Suwon-si, Gyeonggi-do, 16675, Korea. Line conducted emissions are measured only at the 218 address. The following table identifies which facilities were utilized for radiated emission measurements documented in this report. Specific facilities are also identified in the test results sections.

218 Maeyeong-ro	
<input type="checkbox"/>	Chamber 1
<input checked="" type="checkbox"/>	Chamber 2

UL Korea, Ltd. is accredited by IAS, Laboratory Code TL-637. The full scope of accreditation can be viewed at <http://www.iasonline.org/PDF/TL/TL-637.pdf>.

4. CALIBRATION AND UNCERTAINTY

4.1. MEASURING INSTRUMENT CALIBRATION

The measuring equipment utilized to perform the tests documented in this report has been calibrated in accordance with the manufacturer's recommendations, and is traceable to recognized national standards.

4.2. SAMPLE CALCULATION

Where relevant, the following sample calculation is provided:

EIRP = PSA reading with EUT worst orientation (dBm) + Path loss (dB) – cable loss(between the SG and substitution antenna) + Substitution Antenna Factor (dBi)

ERP = PSA reading with EUT worst orientation (dBm) + Path loss (dB) – cable loss(between the SG and substitution antenna)
 (Path loss = Signal generator output – PSA reading with substitution antenna)

4.3. MEASUREMENT UNCERTAINTY

Where relevant, the following measurement uncertainty levels have been estimated for tests performed on the apparatus:

PARAMETER	UNCERTAINTY
Conducted Disturbance, 0.15 to 30 MHz	2.32 dB
Radiated Disturbance, Below 1GHz	4.14 dB
Radiated Disturbance, Above 1 GHz	5.97 dB

Uncertainty figures are valid to a confidence level of 95%.

5. EQUIPMENT UNDER TEST

5.1. DESCRIPTION OF EUT

The EUT is a CDMA Watch + Bluetooth/BLE and DTS b/g/n.

5.2. MAXIMUM OUTPUT POWER

The transmitter has a maximum peak conducted and radiated ERP / EIRP output powers as follows:

FCC Part 22/24						
Band	Frequency Range	Modulation	Conducted		Radiated	
	[MHz]		Peak	Avg [dBm]	Avg [mW]	Avg [dBm]
BC0	824~849	1xRTT	24.64	291.07	0.56	1.14
		EVDO REL. 0	24.7	295.12	0.74	1.19
		EVDO REV. A	24.7	295.12		
BC1	1850~1910	1xRTT	24.67	293.09	19.4	87.1
		EVDO REL. 0	24.69	294.44	19.38	86.7
		EVDO REV. A	24.71	295.80		

DESCRIPTION OF AVAILABLE ANTENNAS

The radio utilizes a FPCB antenna for the [List the bands supported] with a maximum peak gain as follow:

Frequency (MHz)	Peak Gain (dBi)
CDMA BC0 824 ~ 849 MHz	-11
CDMA BC1 1850 ~ 1910 MHz	-8.2

5.3. DESCRIPTION OF TEST SETUP

SUPPORT EQUIPMENT

Support Equipment List				
Description	Manufacturer	Model	Serial Number	FCC ID
Adapter	SAMSUNG	EP-TA20JWE	R37GB7Q0FK2SE3	N/A
Data Cable	SAMSUNG	EP-DG925UWZ	N/A	N/A
Wireless Charger	SAMSUNG	EP-OR720	RF7G91V4JKJTY5	A3LEPOR720

I/O CABLES

I/O Cable List						
Cable No	Port	# of identical ports	Connector Type	Cable Type	Cable Length (m)	Remarks
1	DC Power	1	Mini-USB	Shielded	0.8m	N/A

TEST SETUP

The EUT is continuously communicated to the call box during the tests.

SETUP DIAGRAM FOR TESTS (CONDUCTED TEST SETUP)

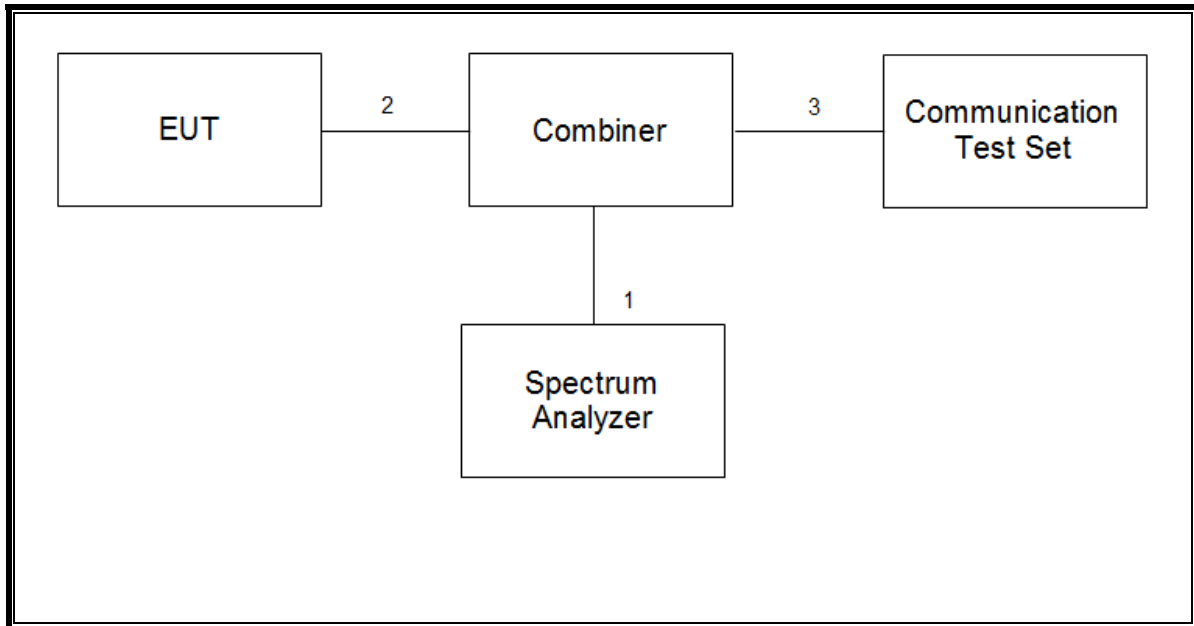

SETUP DIAGRAM FOR TESTS (RADIATED TEST SETUP)

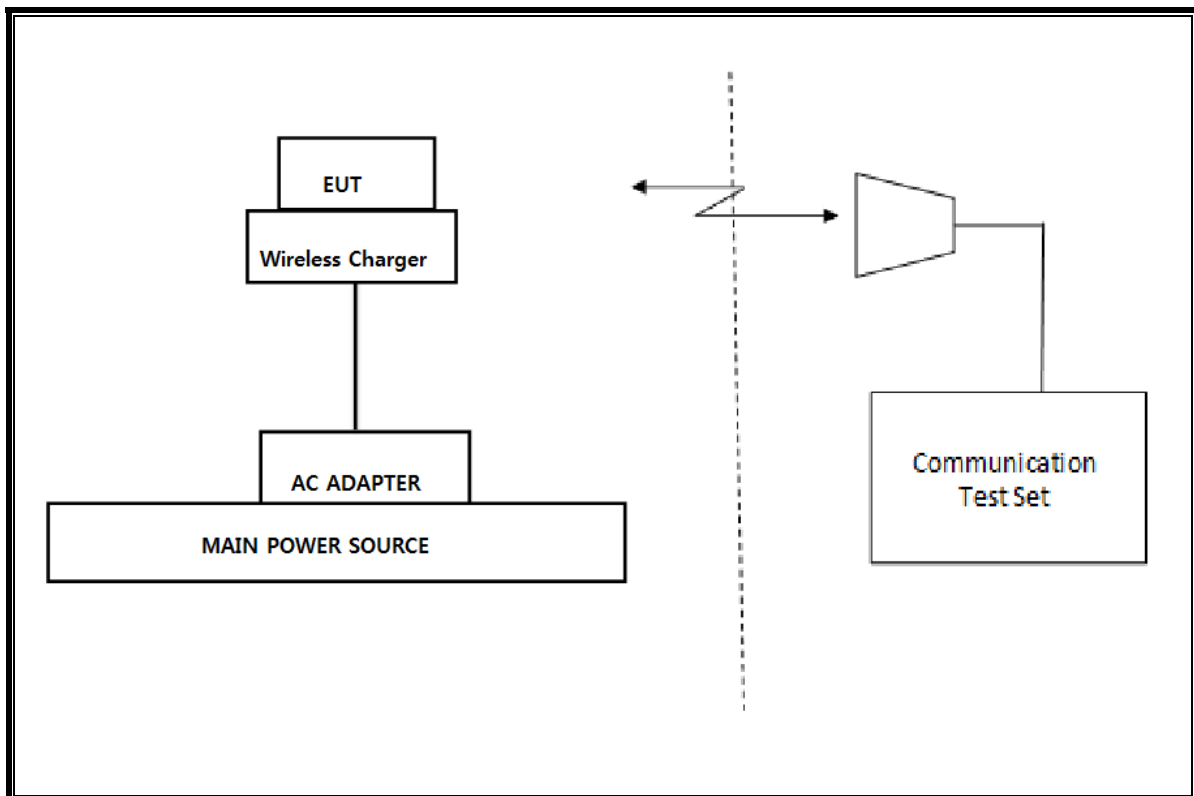

6. TEST AND MEASUREMENT EQUIPMENT

The following test and measurement equipment was utilized for the tests documented in this report:

Test Equipment List				
Description	Manufacturer	Model	S/N	Cal Due
Antenna, Tuned Dipole 400~1000 MHz	ETS	3121D DB4	00164753	07-28-16
Antenna, Bilog, 30MHz-1GHz	SCHWARZBECK	VULB9163	750	11-17-15
Antenna, Bilog, 30MHz-1GHz	SCHWARZBECK	VULB9163	749	04-25-16
Antenna, Horn, 18 GHz	ETS	3115	00167211	09-20-15
Antenna, Horn, 18 GHz	ETS	3115	00161451	05-17-16
Antenna, Horn, 18 GHz	ETS	3117	00168724	06-17-16
Antenna, Horn, 18 GHz	ETS	3117	00168717	06-17-16
Antenna, Horn, 40 GHz	ETS	3116C	00166255	09-23-15
Antenna, Horn, 40 GHz	ETS	3116C-PA	00168841	09-29-15
Combiner	WEINSCHTEL	1575	2153	08-20-16
Communications Test Set	R&S	CMW500	150312	08-18-16
Communications Test Set	R&S	CMW500	115331	08-18-16
Communications Test Set	R&S	CMW500	102271	08-18-16
DC Power Supply	Agilent / HP	E3640A	MY54226395	08-18-16
Preamplifier, 1000 MHz	Sonoma	310N	341282	08-18-16
Preamplifier, 1000 MHz	Sonoma	310N	351741	08-18-16
Preamplifier, 18 GHz	Miteq	AFS42-00101800-25-S-42	1876511	08-18-16
Preamplifier, 18 GHz	Miteq	AFS42-00101800-25-S-42	1896138	08-18-16
Spectrum Analyzer, 44 GHz	Agilent / HP	N9030A	MY54170614	08-19-16
Spectrum Analyzer, 44 GHz	Agilent / HP	N9030A	MY54490312	08-19-16
Bluetooth Tester	TESCOM	TC-3000C	3000C000546	08-18-16
Average Power Sensor	R&S	NRZ-Z91	102681	08-18-16
Average Power Sensor	Agilent / HP	U2000	MY54270007	08-18-16
EMI Test Receive, 40 GHz	R&S	ESU40	100439	08-19-16
EMI Test Receive, 40 GHz	R&S	ESU40	100457	08-19-16
EMI Test Receive, 3 GHz	R&S	ESR3	101832	08-19-16
Attenuator / Switch driver	HP	11713A	3748A04272	N/A
Low Pass Filter 3GHz	Micro-Tronics	LPS17541	009	08-18-16
Low Pass Filter 3GHz	Micro-Tronics	LPS17541	015	08-18-16
High Pass Filter 5GHz	Micro-Tronics	HPS17542	009	08-18-16
High Pass Filter 6GHz	Micro-Tronics	HPM17543	010	08-18-16
High Pass Filter 5GHz	Micro-Tronics	HPS17542	016	08-18-16
High Pass Filter 6GHz	Micro-Tronics	HPM17543	015	08-18-16
LISN	R&S	ENV-216	101836	08-19-16
LISN	R&S	ENV-216	101837	08-19-16

7. Summary Table

FCC Part Section	Test Description	Test Limit	Test Condition	Test Result	Note
2.1049	Occupied Band width (99%)	N/A	Conducted	Pass	1.3056MHz
22.917(a) 24.238(a)	Band Edge / Conducted Spurious Emission	-13dBm		Pass	-13.548dBm
2.1046	Conducted output power	N/A		Pass	24.71dBm
22.355 24.235	Frequency Stability	2.5PPM		Pass	-0.013PPM
22.913(a)(2)	Effective Radiated Power	38 dBm	Radiated	Pass	0.74dBm
24.232(c)	Equivalent Isotropic Radiated Power	33dBm		Pass	19.4dBm
22.917(a) 24.238(a)	Radiated Spurious Emission	-13dBm		Pass	-21.1dBm

FCC Rule Part	Frequency Range [MHz]	Output Power [W]	Frequency Tolerance	Emission Designator	Emission Bandwidth	Communication Type
CDMA						
22H	824.7 - 848.31	0.001	2.5 ppm	1M28F9W		BC0
24E	1851.25 - 1908.75	0.087	2.5 ppm	1M30F9W		BC1

8.1.1. 1xRTT OUTPUT POWER RESULT

Band	Mode	Ch	Freq. (MHz)	Avg Pwr (dBm)
BC0	RC1, SO55 (Loopback)	1013	824.70	24.55
		384	836.52	24.56
		777	848.31	24.57
	RC3, SO55 (Loopback)	1013	824.70	24.64
		384	836.52	24.62
		777	848.31	24.59
	RC3, SO32 (+F-SCH)	1013	824.70	24.54
		384	836.52	24.53
		777	848.31	24.52

Band	Mode	Ch	Freq. (MHz)	Avg Pwr (dBm)
BC1	RC1, SO55 (Loopback)	25	1851.25	24.55
		600	1880.00	24.49
		1175	1908.75	24.51
	RC3, SO55 (Loopback)	25	1851.25	24.55
		600	1880.00	24.55
		1175	1908.75	24.55
	RC3, SO32 (+F-SCH)	25	1851.25	24.56
		600	1880.00	24.56
		1175	1908.75	24.67

8.2. 1xEV-DO Release 0

TEST PROCEDURE

This procedure assumes the Agilent 8960 Test Set has the following applications installed and with valid license.

<u>Application</u>	<u>Rev. License</u>
1xEV-DO Terminal Test	A.09.13

EVDO Release 0 - RTAP

- Call Setup > Shift & Preset
- Call Control:
 - Access Network Info > Cell Parameters > Sector ID > 00000000 > Subnet Mask > 0
 - Generator Info > Termination Parameters > Max Forward Packet Duration > 16 Slots
- Call Params:
 - Cell Power > -105.5 dBm/1.23 MHz
 - Cell Band > (Select US Cellular or US PCS)
 - Channel > (Enter channel number)
 - Application Config > Enhanced Test Application Protocol > RTAP
 - RTAP Rate > 153.6 kbps
 - Rvs Power Ctrl > Active bits
 - Protocol Rel > 0 (1xEV-DO)
- Press "Start Data Connection" when "Session Open" appear in "Active Cell"
- Rvs Power Ctrl > All Up bits (Maximum TxPout)

EVDO Release 0 - FTAP

- Call Setup > Shift & Preset
- Call Control:
 - Access Network Info > Cell Parameters > Sector ID > 00000000 > Subnet Mask > 0
 - Generator Info > Termination Parameters > Max Forward Packet Duration > 16 Slots
- Call Params:
 - Cell Power > -105.5 dBm/1.23 MHz
 - Cell Band > (Select US Cellular or US PCS)
 - Channel > (Enter channel number)
 - Application Config > Enhanced Test Application Protocol > FTAP (default)
 - FTAP Rate > 307.2 kbps (2 Slot, QPSK)
 - Rvs Power Ctrl > Active bits
 - Protocol Rel > 0 (1xEV-DO)
- Press "Start Data Connection" when "Session Open" appear in "Active Cell"
- Rvs Power Ctrl > All Up bits (Maximum TxPout)

8.2.1. 1xEVDO REL.0 OUTPUT POWER RESULT

Band	FTAP Rate	Channel	f (MHz)	Avg Pwr (dBm)
BC0	307.2 kbps (2 slot, QPSK)	1013	824.70	24.69
		384	836.52	24.65
		777	848.31	24.70

Band	FTAP Rate	Channel	f (MHz)	Avg Pwr (dBm)
BC1	307.2 kbps (2 slot, QPSK)	25	1851.25	24.60
		600	1880.00	24.63
		1175	1908.75	24.69

8.3. 1xEV-DO Rev. A

TEST PROCEDURE

This procedure assumes the Agilent 8960 Test Set has the following applications installed and with valid license.

<u>Application</u>	<u>Rev, License</u>
1xEV-DO Terminal Test	A.09.13

EVDO Release A – RETAP

- Call Setup > Shift & Preset
- Cell Power > -60 dBm/1.23 MHz
- Protocol Rev > A (1xEV-DO-A)
- Application Config > Enhanced Test Application Protocol > RETAP
- R-Data Pkt Size > 4096
- Protocol Subtype Config > Release A Physical Layer Subtype > Subtype 2
- > PL Subtype 2 Access Channel MAC Subtype > Default (Subtype 0)
- Access Network Info > Cell Parameters > Sector ID > 00000000 > Subnet Mask > 0
- Generator Info > Termination Parameters > Max Forward Packet Duration >16 Slots > ACK R-Data After > Subpacket 0 (All ACK)
- Rvs Power Ctrl > All Up bits (to get the maximum power)

EVDO Release A - FETAP

- Call Setup > Shift & Preset
- Cell Power > -60 dBm/1.23 MHz
- Protocol Rev > A (1xEV-DO-A)
- Application Config > Enhanced Test Application Protocol > FETAP
- F-Traffic Format > 4 (1024, 2,128) Canonical (307.2k, QPSK)
- Protocol Subtype Config > Release A Physical Layer Subtype > Subtype 2
- > PL Subtype 2 Access Channel MAC Subtype > Default (Subtype 0)
- Access Network Info > Cell Parameters > Sector ID > 00000000 > Subnet Mask > 0
- Generator Info > Termination Parameters > Max Forward Packet Duration >16 Slots > ACK R-Data After > Subpacket 0 (All ACK)
- Rvs Power Ctrl > All Up bits (to get the maximum power)

8.3.1. 1xEVDO REL.A OUTPUT POWER RESULT

1xEVDO REV A OUTPUT RESULT

Band	FTAP Rate	Channel	f (MHz)	Avg Pwr (dBm)
BC0	307.2 kbps (2 slot, QPSK)	1013	824.70	24.70
		384	836.52	24.68
		777	848.31	24.70

Band	FTAP Rate	Channel	f (MHz)	Avg Pwr (dBm)
BC1	307.2 kbps (2 slot, QPSK)	25	1851.25	24.60
		600	1880.00	24.68
		1175	1908.75	24.71

9. PEAK TO AVERAGE RATIO

Test Procedure

Per KDB 971168 D01 Power Meas License Digital Systems v02r02;

The transmitter output was connected to a CMW500 Test Set and configured to operate at maximum power. The PAR were measured on the Spectrum Analyzer.

Test Spec

In addition, when the transmitter power is measured in terms of average value, the peak-to-average ratio of the power shall not exceed 13 dB.

9.1. CONDUCTED PEAK TO AVERAGE RESULT

CDMA

Band	Channel	f [MHz]	Mode	Ratio [dB]	Limit [dB]
BC0	384	836.52	1xRTT	2.87	13.00
			EVDO Rel.0	3.51	
BC1	600	1880.0	1xRTT	2.25	
			EVDO Rel.0	3.48	

9.2. CONDUCTED PEAK TO AVERAGE PLOTS

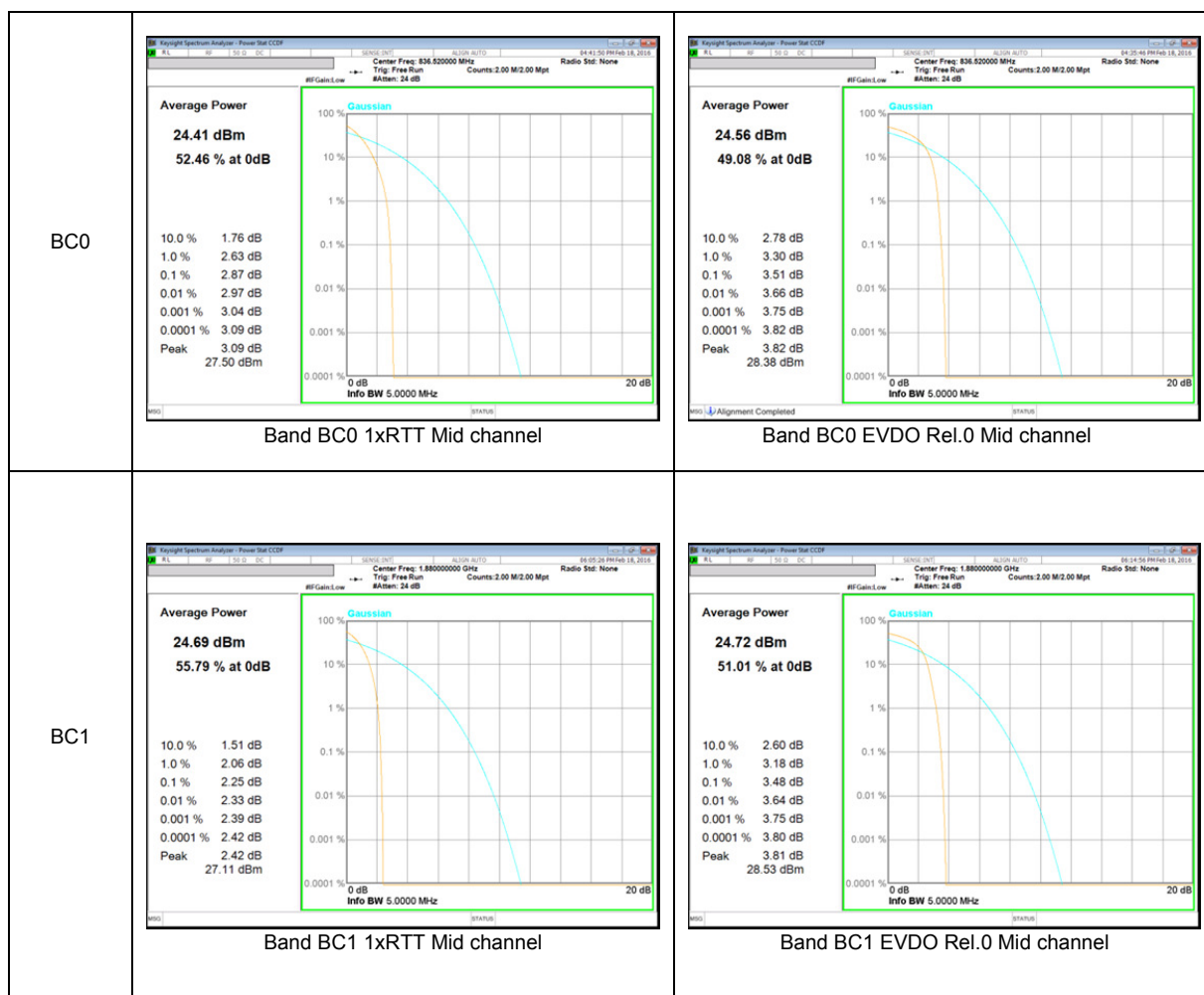

10. LIMITS AND CONDUCTED RESULTS

10.1. OCCUPIED BANDWIDTH

RULE PART(S)

FCC: §2.1049

LIMITS

For reporting purposes only

TEST PROCEDURE

The transmitter output was connected to a calibrated coaxial cable and coupler, the other end of which was connected to a spectrum analyzer. The occupied bandwidth was measured with the spectrum analyzer at the low, middle and high channel in each band. The -26dB bandwidth was also measured and recorded.

(KDB 971168 D01 Power Meas License Digital Systems v02r02)

10.1.1. OCCUPIED BANDWIDTH RESULTS

CDMA

Band	Mode	Channel	f [MHz]	99% BW [KHz]	26dB BW [KHz]
BC0	1xRTT	1013	824.70	1.2814	1.446
		384	836.52	1.2761	1.429
		777	848.31	1.2731	1.437
	EVDO Rel.0	1013	824.70	1.2811	1.445
		384	836.52	1.2763	1.427
		777	848.31	1.2740	1.433
BC1	1xRTT	25	1851.25	1.2857	1.443
		600	1880.00	1.2815	1.464
		1175	1908.75	1.2858	1.461
	EVDO Rel.0	25	1851.25	1.2906	1.881
		600	1880.00	1.2786	1.599
		1175	1908.75	1.3056	1.921

10.1.2. OCCUPIED BANDWIDTH PLOTS

CDMA





10.2. BAND EDGE EMISSIONS

RULE PART(S)

FCC: §22.359, §24.238

LIMITS

The power of any emission outside of the authorized operating frequency ranges must be attenuated below the transmitting power (P) by a factor of at least $43 + 10 \log (P)$ dB.

TEST PROCEDURE

Per KDB 971168 D01 Power Meas License Digital Systems v02r02

The transmitter output was connected to a CMW500 Test Set and configured to operate at maximum power. The band edge emissions were measured at the required operating frequencies in each band on the Spectrum Analyzer.

RESULTS

CDMA

Band	Mode	Side	f [MHz]	Level [dBm]	Limit [dBm]
BC0	1xRTT	Lower	824	-15.709	-13.00
		Upper	849	-13.548	
	EVDO Rel.0	Lower	824	-16.571	
		Upper	849	-13.767	
BC1	1xRTT	Lower	1850	-26.718	
		Upper	1910	-27.848	
	EVDO Rel.0	Lower	1850	-25.585	
		Upper	1910	-22.520	

10.2.1. BAND EDGE PLOTS

CDMA

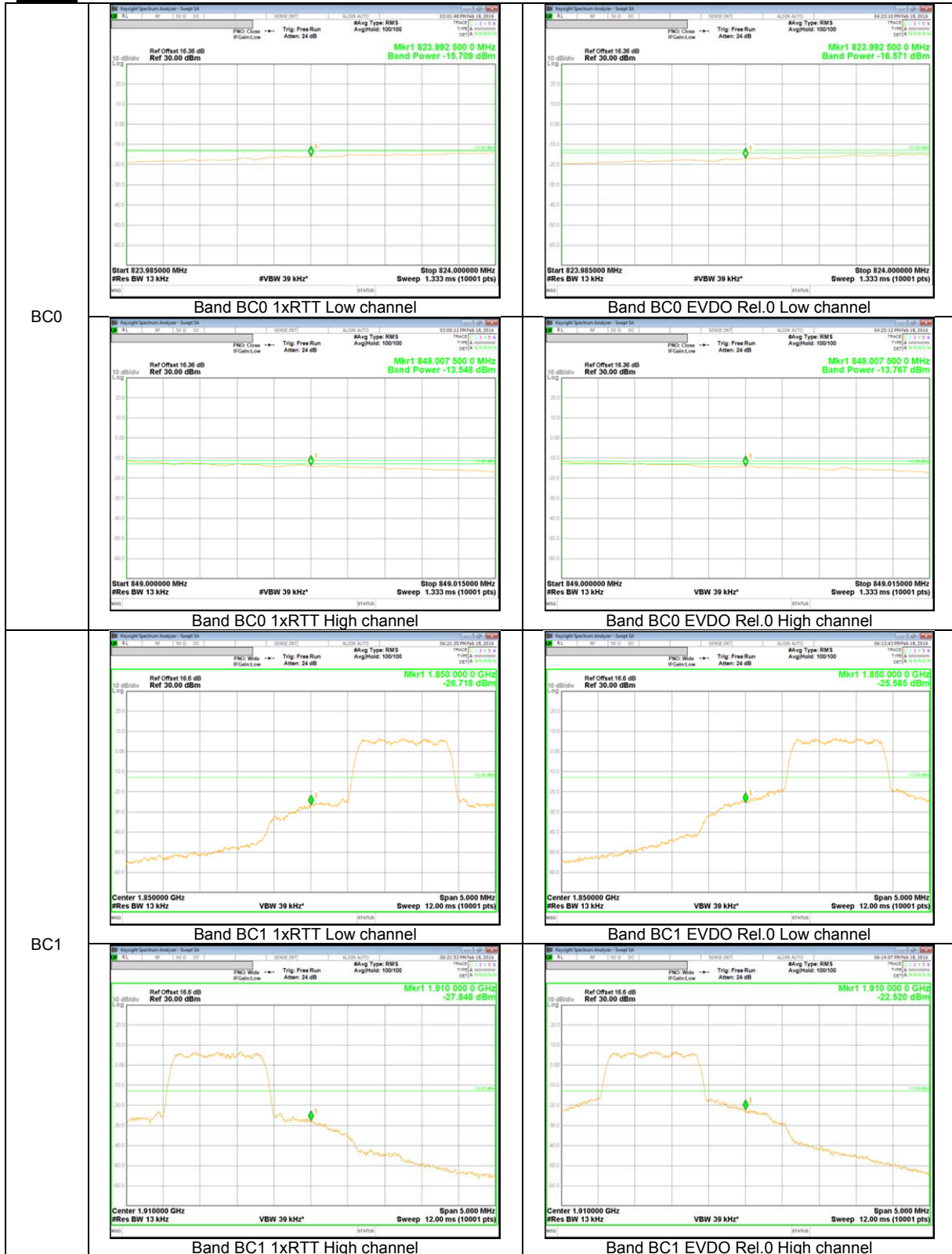

10.3. OUT OF BAND EMISSIONS

RULE PART(S)

FCC: §2.1051, §22.901, §22.917, §24.238

LIMITS

The power of any emission outside of the authorized operating frequency ranges must be attenuated below the transmitting power (P) by a factor of at least $43 + 10 \log (P)$ dB.

TEST PROCEDURE

Per KDB 971168 D01 Power Meas License Digital Systems v02r02

The RF output of the transmitter was connected to a spectrum analyzer through a calibrated coaxial cable. Sufficient scans were taken to show the out-of-band Emissions, if any, up to 10th harmonic. Multiple sweeps were recorded in maximum hold mode using a peak detector to ensure that the worst-case emissions were caught.

RESULTS

10.3.1. OUT OF BAND EMISSIONS RESULT

CDMA

Band	Mode	f [MHz]	Spurious [dBm]	Limit [dBm]	Margin [dB]
BC0	1xRTT	1013	-33.866	-13.00	20.866
		384	-33.643		20.643
		777	-34.092		21.092
	EVDO Rel.0	1013	-34.376		21.376
		384	-34.136		21.136
		777	-33.402		20.402
BC1	1xRTT	25	-31.569		18.569
		600	-29.559		16.559
		1175	-33.394		20.394
	EVDO Rel.0	25	-30.919	17.919	
		600	-29.510	16.51	
		1175	-31.919	18.919	

10.3.2. OUT OF BAND EMISSIONS PLOTS

CDMA

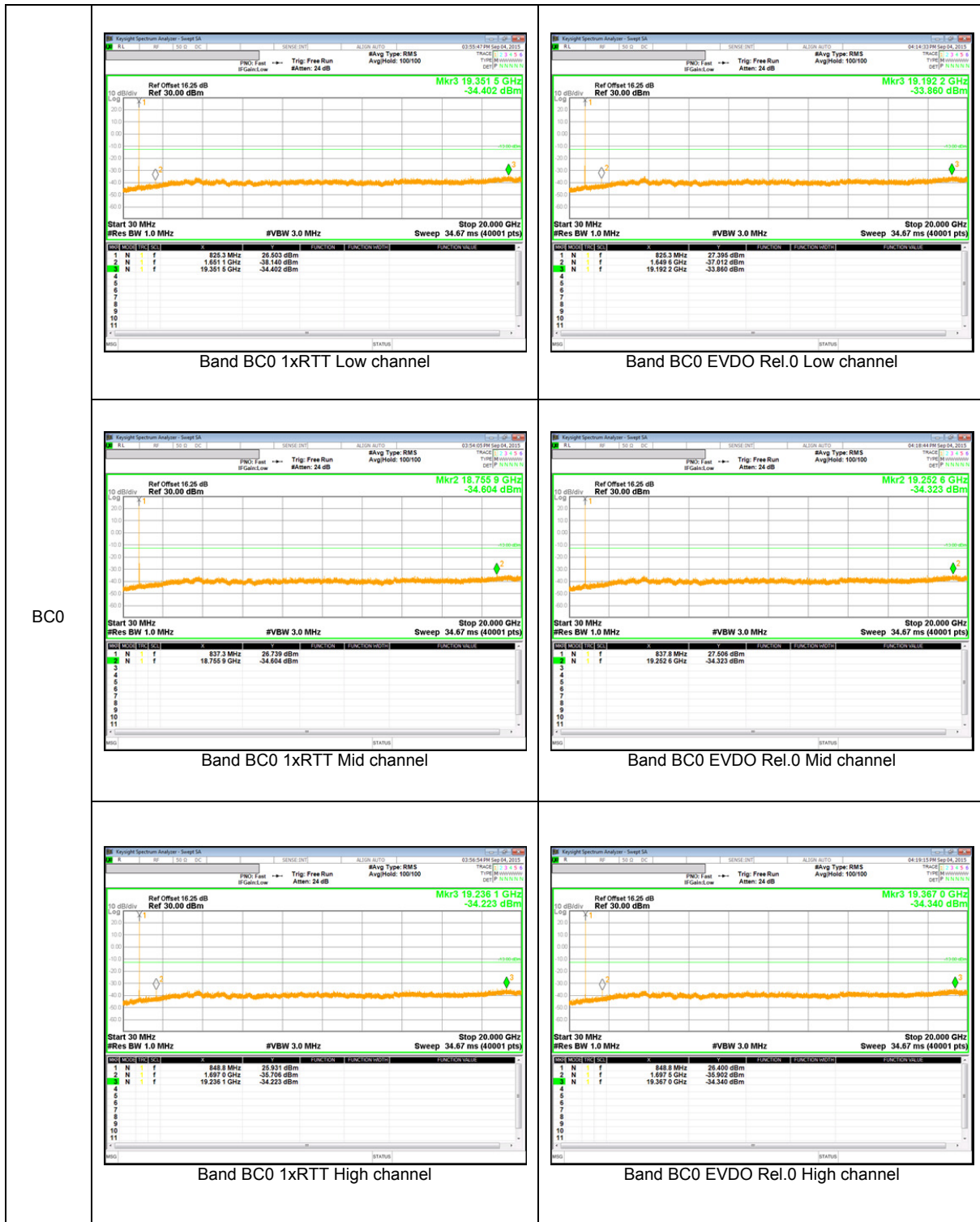

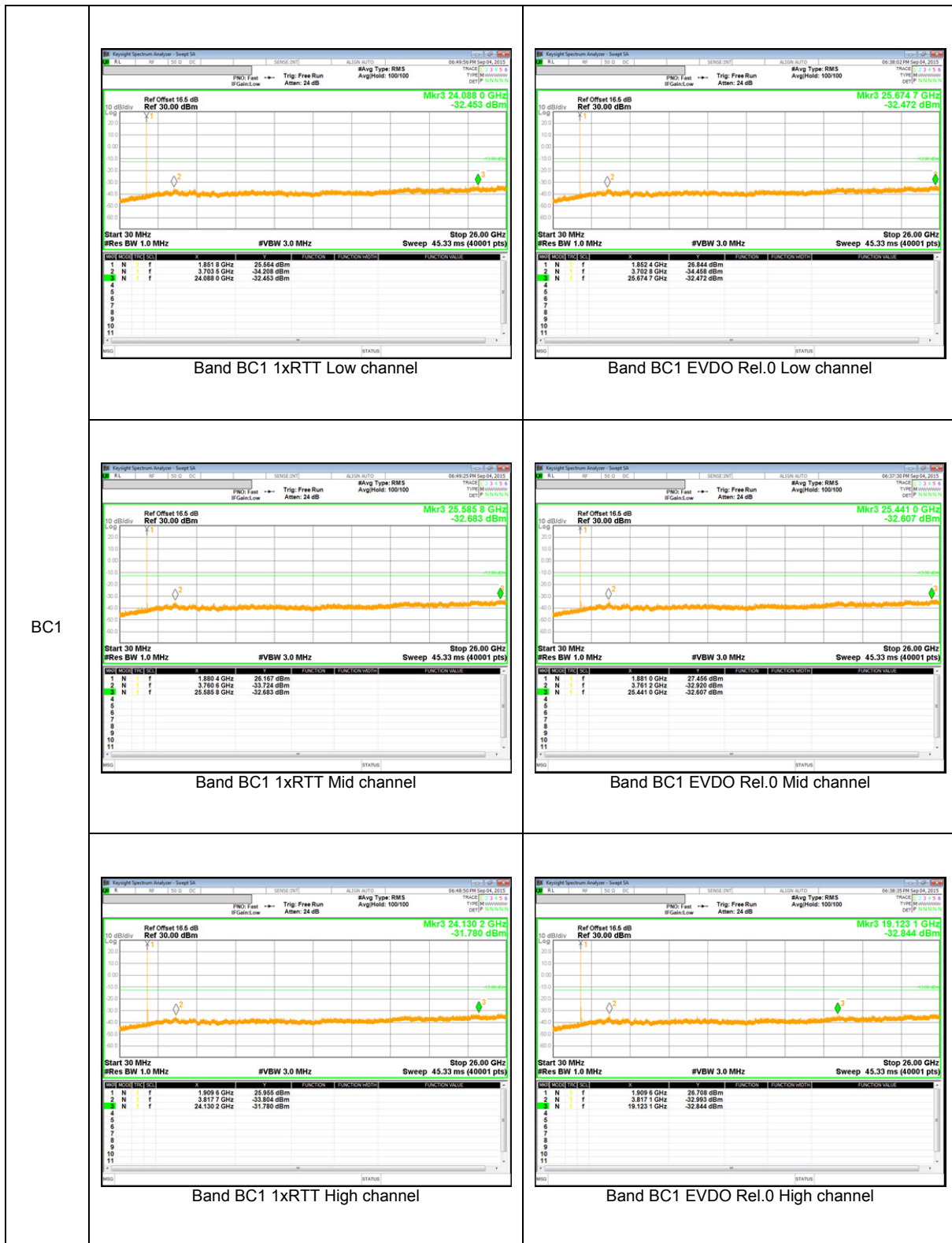

10.4. FREQUENCY STABILITY

RULE PART(S)

FCC: §2.1055, §22.355, §24.235

LIMITS

§22.355 - The carrier frequency shall not depart from the reference frequency in excess of ± 2.5 ppm for mobile stations.

§24.235 - The frequency stability shall be sufficient to ensure that the fundamental emission stays within the authorized frequency block.

TEST PROCEDURE

Per KDB 971168 D01 Power Meas License Digital Systems v02r02

RESULTS

See the following pages.

10.4.1. FREQUENCY STABILITY RESULTS

BC0 1xRTT , Channel 384, Frequency 836.52 MHz

BC0 EVDO Rel.0 , Channel 384, Frequency 836.52 MHz

Reference Frequency: Cellular Mid Channel 836.52 MHz @ 20°C				
Limit: ± 2.5 ppm = 2091.300 Hz				
Power Supply (Vdc)	Environment Temperature (°C)	Frequency Deviation Measured with Time Elapse		
		(MHz)	Delta (ppm)	Limit (ppm)
3.80	50	836.51998762	-0.005	2.5
3.80	40	836.51998271	0.001	2.5
3.80	30	836.51998283	0.001	2.5
3.80	20	836.51998368	0	2.5
3.80	10	836.51998414	-0.001	2.5
3.80	0	836.51998359	0.000	2.5
3.80	-10	836.51998221	0.002	2.5
3.80	-20	836.51998085	0.003	2.5
3.80	-30	836.51997947	0.005	2.5

Reference Frequency: Cellular Mid Channel 836.52 MHz @ 20°C				
Limit: ± 2.5 ppm = 2091.300 Hz				
Power Supply (Vdc)	Environment Temperature (°C)	Frequency Deviation Measured with Time Elapse		
		(MHz)	Delta (ppm)	Limit (ppm)
3.80	20	836.51998368	0	2.5
4.20	20	836.51997746	0.007	2.5
3.50	20	836.51998174	0.002	2.5

BC1 1xRTT , Channel 600, Frequency 1880 MHz

BC1 EVDO Rel.0 , Channel 600, Frequency 1880 MHz

Reference Frequency: PCS Mid Channel 1880 MHz @ 20°C				
Limit: ± 2.5 ppm = 4700.000 Hz				
Power Supply (Vdc)	Environment Temperature (°C)	Frequency Deviation Measured with Time Elapse		
		(MHz)	Delta (ppm)	Limit (ppm)
3.80	50	1879.99998371	-0.001	2.5
3.80	40	1879.99998283	0.000	2.5
3.80	30	1879.99998136	0.001	2.5
3.80	20	1879.99998255	0	2.5
3.80	10	1879.99999138	-0.005	2.5
3.80	0	1879.99998303	0.000	2.5
3.80	-10	1880.00000731	-0.013	2.5
3.80	-20	1879.99997812	0.002	2.5
3.80	-30	1879.99998047	0.001	2.5

Reference Frequency: PCS Mid Channel 1880 MHz @ 20°C				
Limit: ± 2.5 ppm = 4700.000 Hz				
Power Supply (Vdc)	Environment Temperature (°C)	Frequency Deviation Measured with Time Elapse		
		(MHz)	Delta (ppm)	Limit (ppm)
3.80	20	1879.99998255	0	2.5
4.20	20	1879.99997962	0.002	2.5
3.50	20	1879.99998308	0.000	2.5

11. RADIATED TEST RESULTS

11.1. RADIATED POWER (ERP & EIRP)

RULE PART(S)

FCC: §2.1046, §22.913, §24.232

LIMITS

22.913(a) - The ERP of mobile transmitters and auxiliary test transmitters must not exceed 7 Watts.

24.232(c) - Mobile/portable stations are limited to 2 watts e.i.r.p. peak power and the equipment must employ means to limit the power to the minimum necessary for successful communications.

In addition, when the transmitter power is measured in terms of average value, the peak-to-average ratio of the power shall not exceed 13dB.

TEST PROCEDURE

ANSI / TIA / EIA 603D Clause 2.2.17; MXA setting reference to 971168 D01 v02r02

For peak power measurement with a MXA:

a) Set the RBW \geq OBW; b) Set VBW $\geq 3 \times$ RBW; c) Set span $\geq 2 \times$ RBW; d) Sweep time = auto couple; e) Detector = peak; f) Ensure that the number of measurement points \geq span/RBW; g) Trace mode = max hold;

For average power measurement with a MXA:

a) Set span to at least 1.5 times the OBW; b) Set RBW = 1-5% of the OBW, not to exceed 1 MHz; c) Set VBW $\geq 3 \times$ RBW; d) Set number of points in sweep $\geq 2 \times$ span / RBW; e) Sweep time = auto-couple; f) Detector = RMS (power averaging); g) Use free run trigger If burst duty cycle ≥ 98 ; h) Use trigger to capture bursts If burst duty cycle < 98 ; i) Trace average at least 100 traces in power averaging (*i.e.*, RMS) mode. j) Compute the power by integrating the spectrum across the OBW of the signal using the instrument's band power measurement function.

TEST RESULTS

11.1.1. ERP/EIRP Results

CDMA

Band	Mode	Channel	f [MHz]	ERP / EIRP	
				[dBm]	[mW]
BC0	1xRTT	1013	824.70	-0.02	1.00
		384	836.52	0.56	1.14
		777	848.31	-0.28	0.94
	EVDO Rel.0	1013	824.70	0.74	1.19
		384	836.52	0.40	1.10
		777	848.31	-0.35	0.92
BC1	1xRTT	25	1851.25	18.16	65.46
		600	1880.00	19.40	87.10
		1175	1908.75	19.21	83.37
	EVDO Rel.0	25	1851.25	18.58	72.11
		600	1880.00	19.38	86.70
		1175	1908.75	18.72	74.47

11.1.2. ERP/EIRP DATA

BC0

f MHz		SG reading (dBm)	Ant. Pol. (H/V)	Cable Loss (dB)	Antenna Gain (dBd)	ERP (dBm)	Limit (dBm)	Margin (dB)	Notes
824.70		2.60	V	1.1	-1.6	-0.02	38.5	-38.5	
824.70		-7.43	H	1.1	-1.6	-10.06	38.5	-48.5	
Mid Ch									
836.52		3.06	V	1.1	-1.4	0.56	38.5	-37.9	
836.52		-7.43	H	1.1	-1.4	-9.93	38.5	-48.4	
High Ch									
848.31		2.08	V	1.1	-1.3	-0.28	38.5	-38.7	
848.31		-5.29	H	1.1	-1.3	-7.65	38.5	-46.1	

Rev. 3.17.11
 Note: For Band 13/17 ERP limit is 34.77dBm; For Band 26 limit is 50dBm

BC0
1xRTT

BC0
EVDO Rel.0

**High Frequency Substitution Measurement
 UL Korea, Ltd. Suwon Laboratory Chamber 2**

Company: Samsung
Project #: 16K22865
Date: 02-17-16
Test Engineer: Steven.Kim
Configuration: EUT ONLY, X Position
Mode: CDMA RTT BC0

Test Equipment:
 Receiving: VULB9163-749, and 3m Chamber N-type Cable (Setup this one for testing EUT)
 Substitution: Dipole S/N: 00164753, 3m SMA Cable Warehouse.

**High Frequency Substitution Measurement
 UL Korea, Ltd. Suwon Laboratory Chamber 2**

Company: Samsung
Project #: 16K22865
Date: 02-19-16
Test Engineer: Steven.Kim
Configuration: EUT ONLY, X Position
Mode: CDMA EVDO BC0

Test Equipment:
 Receiving: VULB9163-749, and 3m Chamber N-type Cable (Setup this one for testing EUT)
 Substitution: Dipole S/N: 00164753, 3m SMA Cable Warehouse.

BC1

High Frequency Substitution Measurement UL Korea, Ltd. Suwon Laboratory Chamber 2										
BC1 1xRTT	Company:		Samsung							
	Project #:		16K22865							
	Date:		02-19-16							
	Test Engineer:		Steven.Kim							
	Configuration:		EUT ONLY, Z Position							
	Mode:		CDMA RTT BC1							
	Test Equipment:									
	Receiving: 3117[00168724] and Chamber 1 SMA Cables									
	Substitution: 3115[00161451] Substitution, 3m SMA Cable Warehouse									
	f GHz	SG reading (dBm)	Ant. Pol. (H/V)	Cable Loss (dB)	Antenna Gain (dBi)	EIRP (dBm)	Limit (dBm)	Delta (dB)	Notes	
Low Ch										
1851.30	5.3	V	1.60	8.80	12.52	33.0	-20.5			
1851.30	11.0	H	1.60	8.80	18.16	33.0	-14.8			
Mid Ch										
1880.00	3.0	V	1.62	8.62	10.02	33.0	-23.0			
1880.00	12.4	H	1.62	8.62	19.40	33.0	-13.6			
High Ch										
1908.80	7.9	V	1.63	8.44	14.70	33.0	-18.3			
1908.80	12.4	H	1.63	8.44	19.21	33.0	-13.8			
Rev. 3.17.11										

High Frequency Substitution Measurement UL Korea, Ltd. Suwon Laboratory Chamber 2										
BC1 EVDO Rel.0	Company:		Samsung							
	Project #:		16K22865							
	Date:		02-19-16							
	Test Engineer:		Steven.Kim							
	Configuration:		EUT ONLY, Z Position							
	Mode:		CDMA EVDO BC1							
	Test Equipment:									
	Receiving: 3117[00168724] and Chamber 1 SMA Cables									
	Substitution: 3115[00161451] Substitution, 3m SMA Cable Warehouse									
	f GHz	SG reading (dBm)	Ant. Pol. (H/V)	Cable Loss (dB)	Antenna Gain (dBi)	EIRP (dBm)	Limit (dBm)	Delta (dB)	Notes	
Low Ch										
1851.30	1.6	V	1.60	8.80	8.83	33.0	-24.2			
1851.30	11.4	H	1.60	8.80	18.58	33.0	-14.4			
Mid Ch										
1880.00	6.3	V	1.62	8.62	13.28	33.0	-19.7			
1880.00	12.4	H	1.62	8.62	19.38	33.0	-13.6			
High Ch										
1908.80	5.6	V	1.63	8.44	12.36	33.0	-20.6			
1908.80	11.9	H	1.63	8.44	18.72	33.0	-14.3			
Rev. 3.17.11										

11.2. FIELD STRENGTH OF SPURIOUS RADIATION

RULE PART(S)

FCC: §2.1053, §22.917, §24.238

LIMIT

Part 22.917(a) & Part 24.238(a) The power of any emission outside of the authorized operating frequency ranges must be attenuated below the transmitting power (P) by a factor of at least $43 + 10 \log (P)$ dB.

TEST PROCEDURE

For Cellular equipment - Compliance with these rules is based on the use of measurement instrumentation employing a resolution bandwidth of 100 kHz or greater. In the 1 MHz bands immediately outside and adjacent to the frequency block a resolution bandwidth of at least one percent of the emission bandwidth of the fundamental emission of the transmitter may be employed. A narrower resolution bandwidth is permitted in all cases to improve measurement accuracy provided the measured power is integrated over the full required measurement bandwidth (i.e. 100 kHz or 1 percent of emission bandwidth, as specified). The emission bandwidth is defined as the width of the signal between two points, one below the carrier center frequency and one above the carrier center frequency, outside of which all emissions are attenuated at least 26 dB below the transmitter power.

For PCS equipment - Compliance with these rules is based on the use of measurement instrumentation employing a resolution bandwidth of 1 MHz or greater. However, in the 1 MHz bands immediately outside and adjacent to the frequency block a resolution bandwidth of at least one percent of the emission bandwidth of the fundamental emission of the transmitter may be employed. A narrower resolution bandwidth is permitted in all cases to improve measurement accuracy provided the measured power is integrated over the full required measurement bandwidth (i.e. 1 MHz or 1 percent of emission bandwidth, as specified). The emission bandwidth is defined as the width of the signal between two points, one below the carrier center frequency and one above the carrier center frequency, outside of which all emissions are attenuated at least 26 dB below the transmitter power.

RESULTS

11.2.1. SPURIOUS RADIATION PLOTS

BC0

		UL Korea, Ltd Suwon Laboratory Above 1GHz High Frequency Substitution Measurement									
BC0 1xRTT	Company: Samsung Project #: 16K22865 Date: 02-17-16 Test Engineer: Steven.Kim Configuration: EUT / AC Adapter / Earphone, X Position Mode: CDMA RTT BC0										
	Chamber: Chamber 2 Pre-amplifier: AFS42 Filter: Filter 1 Limit: Part 22										
	f	SG reading	Ant. Pol.	Distance	Preamp	Filter	EIRP	Limit	Delta	Notes	
	GHz	(dBm)	(H/V)	(m)	(dB)	(dB)	(dBm)	(dBm)	(dB)		
	Low Ch, 824.7MHz										
	1.64940	-6.0	V	3.0	39.1	1.0	-44.1	-13.0	-31.1		
	2.47410	-18.6	V	3.0	39.5	1.0	-57.2	-13.0	-44.2		
	3.29880	-15.7	V	3.0	40.1	1.0	-54.8	-13.0	-41.8		
	1.64940	-4.2	H	3.0	39.1	1.0	-42.3	-13.0	-29.3		
	2.47410	-19.9	H	3.0	39.5	1.0	-58.4	-13.0	-45.4		
3.29880	-16.4	H	3.0	40.1	1.0	-55.5	-13.0	-42.5			
Mid Ch, 836.52MHz											
1.67304	-8.9	V	3.0	39.1	1.0	-47.0	-13.0	-34.0			
2.50956	-18.4	V	3.0	39.5	1.0	-56.9	-13.0	-43.9			
3.34608	-14.6	V	3.0	40.1	1.0	-53.7	-13.0	-40.7			
1.67304	-1.1	H	3.0	39.1	1.0	-39.3	-13.0	-26.3			
2.50956	-18.5	H	3.0	39.5	1.0	-57.0	-13.0	-44.0			
3.34608	-14.8	H	3.0	40.1	1.0	-54.0	-13.0	-41.0			
High Ch, 848.31MHz											
1.69662	-5.4	V	3.0	39.1	1.0	-43.5	-13.0	-30.5			
2.54493	-19.1	V	3.0	39.6	1.0	-57.6	-13.0	-44.6			
3.39324	-14.8	V	3.0	40.2	1.0	-54.0	-13.0	-41.0			
1.69662	-5.2	H	3.0	39.1	1.0	-43.4	-13.0	-30.4			
2.54493	-19.2	H	3.0	39.6	1.0	-57.7	-13.0	-44.7			
3.39324	-13.2	H	3.0	40.2	1.0	-52.4	-13.0	-39.4			
Rev. 03.03.09 Note: No other emissions were detected above the system noise floor.											
BC0 EVDO Rel.0	Company: Samsung Project #: 16K22865 Date: 02-19-16 Test Engineer: Steven.Kim Configuration: EUT / AC Adapter / Earphone, X Position Mode: CDMA EVDO BC0										
	Chamber: Chamber 2 Pre-amplifier: AFS42 Filter: Filter 1 Limit: Part 22										
	f	SG reading	Ant. Pol.	Distance	Preamp	Filter	EIRP	Limit	Delta	Notes	
	GHz	(dBm)	(H/V)	(m)	(dB)	(dB)	(dBm)	(dBm)	(dB)		
	Low Ch, 824.7MHz										
	1.64940	-11.8	V	3.0	39.1	1.0	-49.9	-13.0	-36.9		
	2.47410	-18.3	V	3.0	39.5	1.0	-56.8	-13.0	-43.8		
	3.29880	-16.5	V	3.0	40.1	1.0	-55.6	-13.0	-42.6		
	1.64940	-9.7	H	3.0	39.1	1.0	-47.8	-13.0	-34.8		
	2.47410	-19.1	H	3.0	39.5	1.0	-57.6	-13.0	-44.6		
3.29880	-16.1	H	3.0	40.1	1.0	-55.2	-13.0	-42.2			
Mid Ch, 836.52MHz											
1.67304	-12.8	V	3.0	39.1	1.0	-50.9	-13.0	-37.9			
2.50956	-18.0	V	3.0	39.5	1.0	-56.6	-13.0	-43.6			
3.34608	-16.4	V	3.0	40.1	1.0	-55.5	-13.0	-42.5			
1.67304	-13.4	H	3.0	39.1	1.0	-51.5	-13.0	-38.5			
2.50956	-18.7	H	3.0	39.5	1.0	-57.3	-13.0	-44.3			
3.34608	-15.4	H	3.0	40.1	1.0	-54.5	-13.0	-41.5			
High Ch, 848.31MHz											
1.69662	-15.1	V	3.0	39.1	1.0	-53.2	-13.0	-40.2			
2.54493	-18.3	V	3.0	39.6	1.0	-56.8	-13.0	-43.8			
3.39324	-15.8	V	3.0	40.2	1.0	-55.0	-13.0	-42.0			
1.69662	-14.7	H	3.0	39.1	1.0	-52.8	-13.0	-39.8			
2.54493	-18.9	H	3.0	39.6	1.0	-57.4	-13.0	-44.4			
3.39324	-15.6	H	3.0	40.2	1.0	-54.8	-13.0	-41.8			
Rev. 03.03.09 Note: No other emissions were detected above the system noise floor.											

BC1

		UL Korea, Ltd Suwon Laboratory Above 1GHz High Frequency Substitution Measurement																																																																																																																																																																																																																																																																																																																																																																																																																																																																																																	
BC1 1xRTT	Company: Samsung Project #: 16K22865 Date: 02-19-16 Test Engineer: Steven.Kim Configuration: EUT / AC Adapter / Earphone, Z Position Mode: CDMARTT BC1	<div style="display: flex; justify-content: space-around;"> <div style="border: 1px solid black; padding: 2px;">Chamber</div> <div style="border: 1px solid black; padding: 2px;">Pre-amplifier</div> <div style="border: 1px solid black; padding: 2px;">Filter</div> <div style="border: 1px solid black; padding: 2px;">Limit</div> </div> <div style="display: flex; justify-content: space-around; margin-top: 5px;"> <div style="border: 1px solid black; padding: 2px;">Chamber 2</div> <div style="border: 1px solid black; padding: 2px;">AFS42</div> <div style="border: 1px solid black; padding: 2px;">Filter 1</div> <div style="border: 1px solid black; padding: 2px;">Part 24</div> </div> <table border="1" style="width: 100%; border-collapse: collapse; text-align: center;"> <thead> <tr> <th>f GHz</th> <th>SG reading (dBm)</th> <th>Ant. Pol. (H/V)</th> <th>Distance (m)</th> <th>Preamp (dB)</th> <th>Filter (dB)</th> <th>EIRP (dBm)</th> <th>Limit (dBm)</th> <th>Delta (dB)</th> <th>Notes</th> </tr> </thead> <tbody> <tr><td colspan="10">Low Ch, 1851.25MHz</td></tr> <tr><td>3.70250</td><td>2.9</td><td>V</td><td>3.0</td><td>40.5</td><td>1.0</td><td>-36.6</td><td>-13.0</td><td>-23.6</td><td></td></tr> <tr><td>5.55375</td><td>10.6</td><td>V</td><td>3.0</td><td>40.8</td><td>1.0</td><td>-29.2</td><td>-13.0</td><td>-16.2</td><td></td></tr> <tr><td>7.40500</td><td>-6.0</td><td>V</td><td>3.0</td><td>40.8</td><td>1.0</td><td>-45.8</td><td>-13.0</td><td>-32.8</td><td></td></tr> <tr><td>3.70250</td><td>5.8</td><td>H</td><td>3.0</td><td>40.5</td><td>1.0</td><td>-33.7</td><td>-13.0</td><td>-20.7</td><td></td></tr> <tr><td>5.55375</td><td>14.6</td><td>H</td><td>3.0</td><td>40.8</td><td>1.0</td><td>-25.2</td><td>-13.0</td><td>-12.2</td><td></td></tr> <tr><td>7.40500</td><td>-5.3</td><td>H</td><td>3.0</td><td>40.8</td><td>1.0</td><td>-45.1</td><td>-13.0</td><td>-32.1</td><td></td></tr> <tr><td colspan="10">Mid Ch, 1880.0MHz</td></tr> <tr><td>3.76000</td><td>4.5</td><td>V</td><td>3.0</td><td>40.5</td><td>1.0</td><td>-35.1</td><td>-13.0</td><td>-22.1</td><td></td></tr> <tr><td>5.64000</td><td>16.2</td><td>V</td><td>3.0</td><td>40.8</td><td>1.0</td><td>-23.6</td><td>-13.0</td><td>-10.6</td><td></td></tr> <tr><td>7.52000</td><td>-6.3</td><td>V</td><td>3.0</td><td>40.7</td><td>1.0</td><td>-46.0</td><td>-13.0</td><td>-33.0</td><td></td></tr> <tr><td>3.76000</td><td>9.8</td><td>H</td><td>3.0</td><td>40.5</td><td>1.0</td><td>-29.8</td><td>-13.0</td><td>-16.8</td><td></td></tr> <tr><td>5.64000</td><td>17.4</td><td>H</td><td>3.0</td><td>40.8</td><td>1.0</td><td>-22.4</td><td>-13.0</td><td>-9.4</td><td></td></tr> <tr><td>7.52000</td><td>-4.0</td><td>H</td><td>3.0</td><td>40.7</td><td>1.0</td><td>-43.8</td><td>-13.0</td><td>-30.8</td><td></td></tr> <tr><td colspan="10">High Ch, 1908.75 MHz</td></tr> <tr><td>3.81750</td><td>-1.4</td><td>V</td><td>3.0</td><td>40.6</td><td>1.0</td><td>-41.0</td><td>-13.0</td><td>-28.0</td><td></td></tr> <tr><td>5.72625</td><td>16.7</td><td>V</td><td>3.0</td><td>40.8</td><td>1.0</td><td>-23.1</td><td>-13.0</td><td>-10.1</td><td></td></tr> <tr><td>7.63500</td><td>-9.4</td><td>V</td><td>3.0</td><td>40.7</td><td>1.0</td><td>-49.1</td><td>-13.0</td><td>-36.1</td><td></td></tr> <tr><td>3.81750</td><td>2.6</td><td>H</td><td>3.0</td><td>40.6</td><td>1.0</td><td>-36.9</td><td>-13.0</td><td>-23.9</td><td></td></tr> <tr><td>5.72625</td><td>18.7</td><td>H</td><td>3.0</td><td>40.8</td><td>1.0</td><td>-21.1</td><td>-13.0</td><td>-8.1</td><td></td></tr> <tr><td>7.63500</td><td>-8.5</td><td>H</td><td>3.0</td><td>40.7</td><td>1.0</td><td>-48.1</td><td>-13.0</td><td>-35.1</td><td></td></tr> <tr> <td colspan="2">Rev. 03.03.09</td> <td colspan="9">Note: No other emissions were detected above the system noise floor.</td> </tr> <tr> <td rowspan="2">BC1 EVDO Rel.0</td> <td> Company: Samsung Project #: 16K22865 Date: 02-19-16 Test Engineer: Steven.Kim Configuration: EUT / AC Adapter / Earphone, Z Position Mode: CDMAEVDO BC1 </td> <td colspan="9"> <div style="display: flex; justify-content: space-around;"> <div style="border: 1px solid black; padding: 2px;">Chamber</div> <div style="border: 1px solid black; padding: 2px;">Pre-amplifier</div> <div style="border: 1px solid black; padding: 2px;">Filter</div> <div style="border: 1px solid black; padding: 2px;">Limit</div> </div> <div style="display: flex; justify-content: space-around; margin-top: 5px;"> <div style="border: 1px solid black; padding: 2px;">Chamber 2</div> <div style="border: 1px solid black; padding: 2px;">AFS42</div> <div style="border: 1px solid black; padding: 2px;">Filter 1</div> <div style="border: 1px solid black; padding: 2px;">Part 24</div> </div> <table border="1" style="width: 100%; border-collapse: collapse; text-align: center;"> <thead> <tr> <th>f GHz</th> <th>SG reading (dBm)</th> <th>Ant. Pol. (H/V)</th> <th>Distance (m)</th> <th>Preamp (dB)</th> <th>Filter (dB)</th> <th>EIRP (dBm)</th> <th>Limit (dBm)</th> <th>Delta (dB)</th> <th>Notes</th> </tr> </thead> <tbody> <tr><td colspan="10">Low Ch, 1851.25MHz</td></tr> <tr><td>3.70250</td><td>-2.7</td><td>V</td><td>3.0</td><td>40.5</td><td>1.0</td><td>-42.2</td><td>-13.0</td><td>-29.2</td><td></td></tr> <tr><td>5.55375</td><td>6.5</td><td>V</td><td>3.0</td><td>40.8</td><td>1.0</td><td>-33.3</td><td>-13.0</td><td>-20.3</td><td></td></tr> <tr><td>7.40500</td><td>-6.9</td><td>V</td><td>3.0</td><td>40.8</td><td>1.0</td><td>-46.6</td><td>-13.0</td><td>-33.6</td><td></td></tr> <tr><td>3.70250</td><td>1.3</td><td>H</td><td>3.0</td><td>40.5</td><td>1.0</td><td>-38.2</td><td>-13.0</td><td>-25.2</td><td></td></tr> <tr><td>5.55375</td><td>8.6</td><td>H</td><td>3.0</td><td>40.8</td><td>1.0</td><td>-31.2</td><td>-13.0</td><td>-18.2</td><td></td></tr> <tr><td>7.40500</td><td>-6.2</td><td>H</td><td>3.0</td><td>40.8</td><td>1.0</td><td>-46.0</td><td>-13.0</td><td>-33.0</td><td></td></tr> <tr><td colspan="10">Mid Ch, 1880.0MHz</td></tr> <tr><td>3.76000</td><td>-7.6</td><td>V</td><td>3.0</td><td>40.5</td><td>1.0</td><td>-47.1</td><td>-13.0</td><td>-34.1</td><td></td></tr> <tr><td>5.64000</td><td>10.3</td><td>V</td><td>3.0</td><td>40.8</td><td>1.0</td><td>-29.5</td><td>-13.0</td><td>-16.5</td><td></td></tr> <tr><td>7.52000</td><td>-7.0</td><td>V</td><td>3.0</td><td>40.7</td><td>1.0</td><td>-46.7</td><td>-13.0</td><td>-33.7</td><td></td></tr> <tr><td>3.76000</td><td>1.8</td><td>H</td><td>3.0</td><td>40.5</td><td>1.0</td><td>-37.8</td><td>-13.0</td><td>-24.8</td><td></td></tr> <tr><td>5.64000</td><td>14.1</td><td>H</td><td>3.0</td><td>40.8</td><td>1.0</td><td>-25.7</td><td>-13.0</td><td>-12.7</td><td></td></tr> <tr><td>7.52000</td><td>-6.0</td><td>H</td><td>3.0</td><td>40.7</td><td>1.0</td><td>-45.7</td><td>-13.0</td><td>-32.7</td><td></td></tr> <tr><td colspan="10">High Ch, 1908.75 MHz</td></tr> <tr><td>3.81750</td><td>-6.8</td><td>V</td><td>3.0</td><td>40.6</td><td>1.0</td><td>-46.4</td><td>-13.0</td><td>-33.4</td><td></td></tr> <tr><td>5.72625</td><td>12.3</td><td>V</td><td>3.0</td><td>40.8</td><td>1.0</td><td>-27.5</td><td>-13.0</td><td>-14.5</td><td></td></tr> <tr><td>7.63500</td><td>-7.1</td><td>V</td><td>3.0</td><td>40.7</td><td>1.0</td><td>-46.7</td><td>-13.0</td><td>-33.7</td><td></td></tr> <tr><td>3.81750</td><td>-2.2</td><td>H</td><td>3.0</td><td>40.6</td><td>1.0</td><td>-41.8</td><td>-13.0</td><td>-28.8</td><td></td></tr> <tr><td>5.72625</td><td>17.2</td><td>H</td><td>3.0</td><td>40.8</td><td>1.0</td><td>-22.6</td><td>-13.0</td><td>-9.6</td><td></td></tr> <tr><td>7.63500</td><td>-5.8</td><td>H</td><td>3.0</td><td>40.7</td><td>1.0</td><td>-45.4</td><td>-13.0</td><td>-32.4</td><td></td></tr> <tr> <td colspan="2">Rev. 03.03.09</td> <td colspan="9">Note: No other emissions were detected above the system noise floor.</td> </tr> </tbody> </table> </td> </tr> </tbody></table>									f GHz	SG reading (dBm)	Ant. Pol. (H/V)	Distance (m)	Preamp (dB)	Filter (dB)	EIRP (dBm)	Limit (dBm)	Delta (dB)	Notes	Low Ch, 1851.25MHz										3.70250	2.9	V	3.0	40.5	1.0	-36.6	-13.0	-23.6		5.55375	10.6	V	3.0	40.8	1.0	-29.2	-13.0	-16.2		7.40500	-6.0	V	3.0	40.8	1.0	-45.8	-13.0	-32.8		3.70250	5.8	H	3.0	40.5	1.0	-33.7	-13.0	-20.7		5.55375	14.6	H	3.0	40.8	1.0	-25.2	-13.0	-12.2		7.40500	-5.3	H	3.0	40.8	1.0	-45.1	-13.0	-32.1		Mid Ch, 1880.0MHz										3.76000	4.5	V	3.0	40.5	1.0	-35.1	-13.0	-22.1		5.64000	16.2	V	3.0	40.8	1.0	-23.6	-13.0	-10.6		7.52000	-6.3	V	3.0	40.7	1.0	-46.0	-13.0	-33.0		3.76000	9.8	H	3.0	40.5	1.0	-29.8	-13.0	-16.8		5.64000	17.4	H	3.0	40.8	1.0	-22.4	-13.0	-9.4		7.52000	-4.0	H	3.0	40.7	1.0	-43.8	-13.0	-30.8		High Ch, 1908.75 MHz										3.81750	-1.4	V	3.0	40.6	1.0	-41.0	-13.0	-28.0		5.72625	16.7	V	3.0	40.8	1.0	-23.1	-13.0	-10.1		7.63500	-9.4	V	3.0	40.7	1.0	-49.1	-13.0	-36.1		3.81750	2.6	H	3.0	40.6	1.0	-36.9	-13.0	-23.9		5.72625	18.7	H	3.0	40.8	1.0	-21.1	-13.0	-8.1		7.63500	-8.5	H	3.0	40.7	1.0	-48.1	-13.0	-35.1		Rev. 03.03.09		Note: No other emissions were detected above the system noise floor.									BC1 EVDO Rel.0	Company: Samsung Project #: 16K22865 Date: 02-19-16 Test Engineer: Steven.Kim Configuration: EUT / AC Adapter / Earphone, Z Position Mode: CDMAEVDO BC1	<div style="display: flex; justify-content: space-around;"> <div style="border: 1px solid black; padding: 2px;">Chamber</div> <div style="border: 1px solid black; padding: 2px;">Pre-amplifier</div> <div style="border: 1px solid black; padding: 2px;">Filter</div> <div style="border: 1px solid black; padding: 2px;">Limit</div> </div> <div style="display: flex; justify-content: space-around; margin-top: 5px;"> <div style="border: 1px solid black; padding: 2px;">Chamber 2</div> <div style="border: 1px solid black; padding: 2px;">AFS42</div> <div style="border: 1px solid black; padding: 2px;">Filter 1</div> <div style="border: 1px solid black; padding: 2px;">Part 24</div> </div> <table border="1" style="width: 100%; border-collapse: collapse; text-align: center;"> <thead> <tr> <th>f GHz</th> <th>SG reading (dBm)</th> <th>Ant. Pol. (H/V)</th> <th>Distance (m)</th> <th>Preamp (dB)</th> <th>Filter (dB)</th> <th>EIRP (dBm)</th> <th>Limit (dBm)</th> <th>Delta (dB)</th> <th>Notes</th> </tr> </thead> <tbody> <tr><td colspan="10">Low Ch, 1851.25MHz</td></tr> <tr><td>3.70250</td><td>-2.7</td><td>V</td><td>3.0</td><td>40.5</td><td>1.0</td><td>-42.2</td><td>-13.0</td><td>-29.2</td><td></td></tr> <tr><td>5.55375</td><td>6.5</td><td>V</td><td>3.0</td><td>40.8</td><td>1.0</td><td>-33.3</td><td>-13.0</td><td>-20.3</td><td></td></tr> <tr><td>7.40500</td><td>-6.9</td><td>V</td><td>3.0</td><td>40.8</td><td>1.0</td><td>-46.6</td><td>-13.0</td><td>-33.6</td><td></td></tr> <tr><td>3.70250</td><td>1.3</td><td>H</td><td>3.0</td><td>40.5</td><td>1.0</td><td>-38.2</td><td>-13.0</td><td>-25.2</td><td></td></tr> <tr><td>5.55375</td><td>8.6</td><td>H</td><td>3.0</td><td>40.8</td><td>1.0</td><td>-31.2</td><td>-13.0</td><td>-18.2</td><td></td></tr> <tr><td>7.40500</td><td>-6.2</td><td>H</td><td>3.0</td><td>40.8</td><td>1.0</td><td>-46.0</td><td>-13.0</td><td>-33.0</td><td></td></tr> <tr><td colspan="10">Mid Ch, 1880.0MHz</td></tr> <tr><td>3.76000</td><td>-7.6</td><td>V</td><td>3.0</td><td>40.5</td><td>1.0</td><td>-47.1</td><td>-13.0</td><td>-34.1</td><td></td></tr> <tr><td>5.64000</td><td>10.3</td><td>V</td><td>3.0</td><td>40.8</td><td>1.0</td><td>-29.5</td><td>-13.0</td><td>-16.5</td><td></td></tr> <tr><td>7.52000</td><td>-7.0</td><td>V</td><td>3.0</td><td>40.7</td><td>1.0</td><td>-46.7</td><td>-13.0</td><td>-33.7</td><td></td></tr> <tr><td>3.76000</td><td>1.8</td><td>H</td><td>3.0</td><td>40.5</td><td>1.0</td><td>-37.8</td><td>-13.0</td><td>-24.8</td><td></td></tr> <tr><td>5.64000</td><td>14.1</td><td>H</td><td>3.0</td><td>40.8</td><td>1.0</td><td>-25.7</td><td>-13.0</td><td>-12.7</td><td></td></tr> <tr><td>7.52000</td><td>-6.0</td><td>H</td><td>3.0</td><td>40.7</td><td>1.0</td><td>-45.7</td><td>-13.0</td><td>-32.7</td><td></td></tr> <tr><td colspan="10">High Ch, 1908.75 MHz</td></tr> <tr><td>3.81750</td><td>-6.8</td><td>V</td><td>3.0</td><td>40.6</td><td>1.0</td><td>-46.4</td><td>-13.0</td><td>-33.4</td><td></td></tr> <tr><td>5.72625</td><td>12.3</td><td>V</td><td>3.0</td><td>40.8</td><td>1.0</td><td>-27.5</td><td>-13.0</td><td>-14.5</td><td></td></tr> <tr><td>7.63500</td><td>-7.1</td><td>V</td><td>3.0</td><td>40.7</td><td>1.0</td><td>-46.7</td><td>-13.0</td><td>-33.7</td><td></td></tr> <tr><td>3.81750</td><td>-2.2</td><td>H</td><td>3.0</td><td>40.6</td><td>1.0</td><td>-41.8</td><td>-13.0</td><td>-28.8</td><td></td></tr> <tr><td>5.72625</td><td>17.2</td><td>H</td><td>3.0</td><td>40.8</td><td>1.0</td><td>-22.6</td><td>-13.0</td><td>-9.6</td><td></td></tr> <tr><td>7.63500</td><td>-5.8</td><td>H</td><td>3.0</td><td>40.7</td><td>1.0</td><td>-45.4</td><td>-13.0</td><td>-32.4</td><td></td></tr> <tr> <td colspan="2">Rev. 03.03.09</td> <td colspan="9">Note: No other emissions were detected above the system noise floor.</td> </tr> </tbody> </table>									f GHz	SG reading (dBm)	Ant. Pol. (H/V)	Distance (m)	Preamp (dB)	Filter (dB)	EIRP (dBm)	Limit (dBm)	Delta (dB)	Notes	Low Ch, 1851.25MHz										3.70250	-2.7	V	3.0	40.5	1.0	-42.2	-13.0	-29.2		5.55375	6.5	V	3.0	40.8	1.0	-33.3	-13.0	-20.3		7.40500	-6.9	V	3.0	40.8	1.0	-46.6	-13.0	-33.6		3.70250	1.3	H	3.0	40.5	1.0	-38.2	-13.0	-25.2		5.55375	8.6	H	3.0	40.8	1.0	-31.2	-13.0	-18.2		7.40500	-6.2	H	3.0	40.8	1.0	-46.0	-13.0	-33.0		Mid Ch, 1880.0MHz										3.76000	-7.6	V	3.0	40.5	1.0	-47.1	-13.0	-34.1		5.64000	10.3	V	3.0	40.8	1.0	-29.5	-13.0	-16.5		7.52000	-7.0	V	3.0	40.7	1.0	-46.7	-13.0	-33.7		3.76000	1.8	H	3.0	40.5	1.0	-37.8	-13.0	-24.8		5.64000	14.1	H	3.0	40.8	1.0	-25.7	-13.0	-12.7		7.52000	-6.0	H	3.0	40.7	1.0	-45.7	-13.0	-32.7		High Ch, 1908.75 MHz										3.81750	-6.8	V	3.0	40.6	1.0	-46.4	-13.0	-33.4		5.72625	12.3	V	3.0	40.8	1.0	-27.5	-13.0	-14.5		7.63500	-7.1	V	3.0	40.7	1.0	-46.7	-13.0	-33.7		3.81750	-2.2	H	3.0	40.6	1.0	-41.8	-13.0	-28.8		5.72625	17.2	H	3.0	40.8	1.0	-22.6	-13.0	-9.6		7.63500	-5.8	H	3.0	40.7	1.0	-45.4	-13.0	-32.4		Rev. 03.03.09		Note: No other emissions were detected above the system noise floor.								
	f GHz	SG reading (dBm)	Ant. Pol. (H/V)	Distance (m)	Preamp (dB)	Filter (dB)	EIRP (dBm)	Limit (dBm)	Delta (dB)	Notes																																																																																																																																																																																																																																																																																																																																																																																																																																																																																									
Low Ch, 1851.25MHz																																																																																																																																																																																																																																																																																																																																																																																																																																																																																																			
3.70250	2.9	V	3.0	40.5	1.0	-36.6	-13.0	-23.6																																																																																																																																																																																																																																																																																																																																																																																																																																																																																											
5.55375	10.6	V	3.0	40.8	1.0	-29.2	-13.0	-16.2																																																																																																																																																																																																																																																																																																																																																																																																																																																																																											
7.40500	-6.0	V	3.0	40.8	1.0	-45.8	-13.0	-32.8																																																																																																																																																																																																																																																																																																																																																																																																																																																																																											
3.70250	5.8	H	3.0	40.5	1.0	-33.7	-13.0	-20.7																																																																																																																																																																																																																																																																																																																																																																																																																																																																																											
5.55375	14.6	H	3.0	40.8	1.0	-25.2	-13.0	-12.2																																																																																																																																																																																																																																																																																																																																																																																																																																																																																											
7.40500	-5.3	H	3.0	40.8	1.0	-45.1	-13.0	-32.1																																																																																																																																																																																																																																																																																																																																																																																																																																																																																											
Mid Ch, 1880.0MHz																																																																																																																																																																																																																																																																																																																																																																																																																																																																																																			
3.76000	4.5	V	3.0	40.5	1.0	-35.1	-13.0	-22.1																																																																																																																																																																																																																																																																																																																																																																																																																																																																																											
5.64000	16.2	V	3.0	40.8	1.0	-23.6	-13.0	-10.6																																																																																																																																																																																																																																																																																																																																																																																																																																																																																											
7.52000	-6.3	V	3.0	40.7	1.0	-46.0	-13.0	-33.0																																																																																																																																																																																																																																																																																																																																																																																																																																																																																											
3.76000	9.8	H	3.0	40.5	1.0	-29.8	-13.0	-16.8																																																																																																																																																																																																																																																																																																																																																																																																																																																																																											
5.64000	17.4	H	3.0	40.8	1.0	-22.4	-13.0	-9.4																																																																																																																																																																																																																																																																																																																																																																																																																																																																																											
7.52000	-4.0	H	3.0	40.7	1.0	-43.8	-13.0	-30.8																																																																																																																																																																																																																																																																																																																																																																																																																																																																																											
High Ch, 1908.75 MHz																																																																																																																																																																																																																																																																																																																																																																																																																																																																																																			
3.81750	-1.4	V	3.0	40.6	1.0	-41.0	-13.0	-28.0																																																																																																																																																																																																																																																																																																																																																																																																																																																																																											
5.72625	16.7	V	3.0	40.8	1.0	-23.1	-13.0	-10.1																																																																																																																																																																																																																																																																																																																																																																																																																																																																																											
7.63500	-9.4	V	3.0	40.7	1.0	-49.1	-13.0	-36.1																																																																																																																																																																																																																																																																																																																																																																																																																																																																																											
3.81750	2.6	H	3.0	40.6	1.0	-36.9	-13.0	-23.9																																																																																																																																																																																																																																																																																																																																																																																																																																																																																											
5.72625	18.7	H	3.0	40.8	1.0	-21.1	-13.0	-8.1																																																																																																																																																																																																																																																																																																																																																																																																																																																																																											
7.63500	-8.5	H	3.0	40.7	1.0	-48.1	-13.0	-35.1																																																																																																																																																																																																																																																																																																																																																																																																																																																																																											
Rev. 03.03.09		Note: No other emissions were detected above the system noise floor.																																																																																																																																																																																																																																																																																																																																																																																																																																																																																																	
BC1 EVDO Rel.0	Company: Samsung Project #: 16K22865 Date: 02-19-16 Test Engineer: Steven.Kim Configuration: EUT / AC Adapter / Earphone, Z Position Mode: CDMAEVDO BC1	<div style="display: flex; justify-content: space-around;"> <div style="border: 1px solid black; padding: 2px;">Chamber</div> <div style="border: 1px solid black; padding: 2px;">Pre-amplifier</div> <div style="border: 1px solid black; padding: 2px;">Filter</div> <div style="border: 1px solid black; padding: 2px;">Limit</div> </div> <div style="display: flex; justify-content: space-around; margin-top: 5px;"> <div style="border: 1px solid black; padding: 2px;">Chamber 2</div> <div style="border: 1px solid black; padding: 2px;">AFS42</div> <div style="border: 1px solid black; padding: 2px;">Filter 1</div> <div style="border: 1px solid black; padding: 2px;">Part 24</div> </div> <table border="1" style="width: 100%; border-collapse: collapse; text-align: center;"> <thead> <tr> <th>f GHz</th> <th>SG reading (dBm)</th> <th>Ant. Pol. (H/V)</th> <th>Distance (m)</th> <th>Preamp (dB)</th> <th>Filter (dB)</th> <th>EIRP (dBm)</th> <th>Limit (dBm)</th> <th>Delta (dB)</th> <th>Notes</th> </tr> </thead> <tbody> <tr><td colspan="10">Low Ch, 1851.25MHz</td></tr> <tr><td>3.70250</td><td>-2.7</td><td>V</td><td>3.0</td><td>40.5</td><td>1.0</td><td>-42.2</td><td>-13.0</td><td>-29.2</td><td></td></tr> <tr><td>5.55375</td><td>6.5</td><td>V</td><td>3.0</td><td>40.8</td><td>1.0</td><td>-33.3</td><td>-13.0</td><td>-20.3</td><td></td></tr> <tr><td>7.40500</td><td>-6.9</td><td>V</td><td>3.0</td><td>40.8</td><td>1.0</td><td>-46.6</td><td>-13.0</td><td>-33.6</td><td></td></tr> <tr><td>3.70250</td><td>1.3</td><td>H</td><td>3.0</td><td>40.5</td><td>1.0</td><td>-38.2</td><td>-13.0</td><td>-25.2</td><td></td></tr> <tr><td>5.55375</td><td>8.6</td><td>H</td><td>3.0</td><td>40.8</td><td>1.0</td><td>-31.2</td><td>-13.0</td><td>-18.2</td><td></td></tr> <tr><td>7.40500</td><td>-6.2</td><td>H</td><td>3.0</td><td>40.8</td><td>1.0</td><td>-46.0</td><td>-13.0</td><td>-33.0</td><td></td></tr> <tr><td colspan="10">Mid Ch, 1880.0MHz</td></tr> <tr><td>3.76000</td><td>-7.6</td><td>V</td><td>3.0</td><td>40.5</td><td>1.0</td><td>-47.1</td><td>-13.0</td><td>-34.1</td><td></td></tr> <tr><td>5.64000</td><td>10.3</td><td>V</td><td>3.0</td><td>40.8</td><td>1.0</td><td>-29.5</td><td>-13.0</td><td>-16.5</td><td></td></tr> <tr><td>7.52000</td><td>-7.0</td><td>V</td><td>3.0</td><td>40.7</td><td>1.0</td><td>-46.7</td><td>-13.0</td><td>-33.7</td><td></td></tr> <tr><td>3.76000</td><td>1.8</td><td>H</td><td>3.0</td><td>40.5</td><td>1.0</td><td>-37.8</td><td>-13.0</td><td>-24.8</td><td></td></tr> <tr><td>5.64000</td><td>14.1</td><td>H</td><td>3.0</td><td>40.8</td><td>1.0</td><td>-25.7</td><td>-13.0</td><td>-12.7</td><td></td></tr> <tr><td>7.52000</td><td>-6.0</td><td>H</td><td>3.0</td><td>40.7</td><td>1.0</td><td>-45.7</td><td>-13.0</td><td>-32.7</td><td></td></tr> <tr><td colspan="10">High Ch, 1908.75 MHz</td></tr> <tr><td>3.81750</td><td>-6.8</td><td>V</td><td>3.0</td><td>40.6</td><td>1.0</td><td>-46.4</td><td>-13.0</td><td>-33.4</td><td></td></tr> <tr><td>5.72625</td><td>12.3</td><td>V</td><td>3.0</td><td>40.8</td><td>1.0</td><td>-27.5</td><td>-13.0</td><td>-14.5</td><td></td></tr> <tr><td>7.63500</td><td>-7.1</td><td>V</td><td>3.0</td><td>40.7</td><td>1.0</td><td>-46.7</td><td>-13.0</td><td>-33.7</td><td></td></tr> <tr><td>3.81750</td><td>-2.2</td><td>H</td><td>3.0</td><td>40.6</td><td>1.0</td><td>-41.8</td><td>-13.0</td><td>-28.8</td><td></td></tr> <tr><td>5.72625</td><td>17.2</td><td>H</td><td>3.0</td><td>40.8</td><td>1.0</td><td>-22.6</td><td>-13.0</td><td>-9.6</td><td></td></tr> <tr><td>7.63500</td><td>-5.8</td><td>H</td><td>3.0</td><td>40.7</td><td>1.0</td><td>-45.4</td><td>-13.0</td><td>-32.4</td><td></td></tr> <tr> <td colspan="2">Rev. 03.03.09</td> <td colspan="9">Note: No other emissions were detected above the system noise floor.</td> </tr> </tbody> </table>									f GHz	SG reading (dBm)	Ant. Pol. (H/V)	Distance (m)	Preamp (dB)	Filter (dB)	EIRP (dBm)	Limit (dBm)	Delta (dB)	Notes	Low Ch, 1851.25MHz										3.70250	-2.7	V	3.0	40.5	1.0	-42.2	-13.0	-29.2		5.55375	6.5	V	3.0	40.8	1.0	-33.3	-13.0	-20.3		7.40500	-6.9	V	3.0	40.8	1.0	-46.6	-13.0	-33.6		3.70250	1.3	H	3.0	40.5	1.0	-38.2	-13.0	-25.2		5.55375	8.6	H	3.0	40.8	1.0	-31.2	-13.0	-18.2		7.40500	-6.2	H	3.0	40.8	1.0	-46.0	-13.0	-33.0		Mid Ch, 1880.0MHz										3.76000	-7.6	V	3.0	40.5	1.0	-47.1	-13.0	-34.1		5.64000	10.3	V	3.0	40.8	1.0	-29.5	-13.0	-16.5		7.52000	-7.0	V	3.0	40.7	1.0	-46.7	-13.0	-33.7		3.76000	1.8	H	3.0	40.5	1.0	-37.8	-13.0	-24.8		5.64000	14.1	H	3.0	40.8	1.0	-25.7	-13.0	-12.7		7.52000	-6.0	H	3.0	40.7	1.0	-45.7	-13.0	-32.7		High Ch, 1908.75 MHz										3.81750	-6.8	V	3.0	40.6	1.0	-46.4	-13.0	-33.4		5.72625	12.3	V	3.0	40.8	1.0	-27.5	-13.0	-14.5		7.63500	-7.1	V	3.0	40.7	1.0	-46.7	-13.0	-33.7		3.81750	-2.2	H	3.0	40.6	1.0	-41.8	-13.0	-28.8		5.72625	17.2	H	3.0	40.8	1.0	-22.6	-13.0	-9.6		7.63500	-5.8	H	3.0	40.7	1.0	-45.4	-13.0	-32.4		Rev. 03.03.09		Note: No other emissions were detected above the system noise floor.																																																																																																																																																																																																																																																										
	f GHz	SG reading (dBm)	Ant. Pol. (H/V)	Distance (m)	Preamp (dB)	Filter (dB)	EIRP (dBm)	Limit (dBm)	Delta (dB)	Notes																																																																																																																																																																																																																																																																																																																																																																																																																																																																																									
Low Ch, 1851.25MHz																																																																																																																																																																																																																																																																																																																																																																																																																																																																																																			
3.70250	-2.7	V	3.0	40.5	1.0	-42.2	-13.0	-29.2																																																																																																																																																																																																																																																																																																																																																																																																																																																																																											
5.55375	6.5	V	3.0	40.8	1.0	-33.3	-13.0	-20.3																																																																																																																																																																																																																																																																																																																																																																																																																																																																																											
7.40500	-6.9	V	3.0	40.8	1.0	-46.6	-13.0	-33.6																																																																																																																																																																																																																																																																																																																																																																																																																																																																																											
3.70250	1.3	H	3.0	40.5	1.0	-38.2	-13.0	-25.2																																																																																																																																																																																																																																																																																																																																																																																																																																																																																											
5.55375	8.6	H	3.0	40.8	1.0	-31.2	-13.0	-18.2																																																																																																																																																																																																																																																																																																																																																																																																																																																																																											
7.40500	-6.2	H	3.0	40.8	1.0	-46.0	-13.0	-33.0																																																																																																																																																																																																																																																																																																																																																																																																																																																																																											
Mid Ch, 1880.0MHz																																																																																																																																																																																																																																																																																																																																																																																																																																																																																																			
3.76000	-7.6	V	3.0	40.5	1.0	-47.1	-13.0	-34.1																																																																																																																																																																																																																																																																																																																																																																																																																																																																																											
5.64000	10.3	V	3.0	40.8	1.0	-29.5	-13.0	-16.5																																																																																																																																																																																																																																																																																																																																																																																																																																																																																											
7.52000	-7.0	V	3.0	40.7	1.0	-46.7	-13.0	-33.7																																																																																																																																																																																																																																																																																																																																																																																																																																																																																											
3.76000	1.8	H	3.0	40.5	1.0	-37.8	-13.0	-24.8																																																																																																																																																																																																																																																																																																																																																																																																																																																																																											
5.64000	14.1	H	3.0	40.8	1.0	-25.7	-13.0	-12.7																																																																																																																																																																																																																																																																																																																																																																																																																																																																																											
7.52000	-6.0	H	3.0	40.7	1.0	-45.7	-13.0	-32.7																																																																																																																																																																																																																																																																																																																																																																																																																																																																																											
High Ch, 1908.75 MHz																																																																																																																																																																																																																																																																																																																																																																																																																																																																																																			
3.81750	-6.8	V	3.0	40.6	1.0	-46.4	-13.0	-33.4																																																																																																																																																																																																																																																																																																																																																																																																																																																																																											
5.72625	12.3	V	3.0	40.8	1.0	-27.5	-13.0	-14.5																																																																																																																																																																																																																																																																																																																																																																																																																																																																																											
7.63500	-7.1	V	3.0	40.7	1.0	-46.7	-13.0	-33.7																																																																																																																																																																																																																																																																																																																																																																																																																																																																																											
3.81750	-2.2	H	3.0	40.6	1.0	-41.8	-13.0	-28.8																																																																																																																																																																																																																																																																																																																																																																																																																																																																																											
5.72625	17.2	H	3.0	40.8	1.0	-22.6	-13.0	-9.6																																																																																																																																																																																																																																																																																																																																																																																																																																																																																											
7.63500	-5.8	H	3.0	40.7	1.0	-45.4	-13.0	-32.4																																																																																																																																																																																																																																																																																																																																																																																																																																																																																											
Rev. 03.03.09		Note: No other emissions were detected above the system noise floor.																																																																																																																																																																																																																																																																																																																																																																																																																																																																																																	