



SAR EVALUATION REPORT

Applicant Name:
 Samsung Electronics, Co. Ltd.
 129, Samsung-ro, Maetan dong,
 Yeongtong-gu, Suwon-si
 Gyeonggi-do 443-742, Korea

Date of Testing:
 08/14/14 - 08/18/14
Test Site/Location:
 PCTEST Lab, Columbia, MD, USA
Document Serial No.:
 OY1408121709.A3L

FCC ID: A3LSMN915G

APPLICANT: SAMSUNG ELECTRONICS, CO. LTD.

DUT Type: Portable Handset
Application Type: Certification
FCC Rule Part(s): CFR §2.1093
Model(s): SM-N915G

Equipment Class	Band & Mode	Tx Frequency	SAR				
			1 gm Head (W/kg)	1 gm Body-Worn (W/kg)	1 gm Hotspot (W/kg)	10 gm Extremity (W/kg)	
PCE	GSM/GPRS/EDGE 850	824.20 - 848.80 MHz	< 0.1	0.28	0.33		
PCE	GSM/GPRS/EDGE 1900	1850.20 - 1909.80 MHz	0.15	0.21	0.59		
PCE	UMTS 850	826.40 - 846.60 MHz	0.13	0.37	0.42		
PCE	UMTS 1900	1852.4 - 1907.6 MHz	0.25	0.29	0.56		
PCE	LTE Band 5 (Cell)	824.7 - 848.3 MHz	0.10	0.30	0.39		
PCE	LTE Band 4 (AWS)	1710.7 - 1754.3 MHz	< 0.1	0.28	0.47		
PCE	LTE Band 2 (PCS)	1850.7 - 1909.3 MHz	0.20	0.23	0.66		
DTS	2.4 GHz WLAN	2412 - 2462 MHz	0.21	< 0.1	< 0.1		
DTS	5.8 GHz WLAN	5745 - 5825 MHz	< 0.1	0.19		0.32	
NII	5.2 GHz WLAN	5180 - 5240 MHz	< 0.1	0.39		0.62	
NII	5.3 GHz WLAN	5260 - 5320 MHz	< 0.1	0.40		0.71	
NII	5.5 GHz WLAN	5500 - 5700 MHz	0.11	0.43		1.33	
DSS/DTS	Bluetooth	2402 - 2480 MHz	N/A				
Simultaneous SAR per KDB 690783 D01v01r03:			0.45	0.80	0.66	1.33	

This wireless portable device has been shown to be capable of compliance for localized specific absorption rate (SAR) for uncontrolled environment/general population exposure limits specified in ANSI/IEEE C95.1-1992 and has been tested in accordance with the measurement procedures specified in Section 1.8 of this report; for North American frequency bands only.

I attest to the accuracy of data. All measurements reported herein were performed by me or were made under my supervision and are correct to the best of my knowledge and belief. I assume full responsibility for the completeness of these measurements and vouch for the qualifications of all persons taking them. Test results reported herein relate only to the item(s) tested.

Randy Ortanez
 President





The SAR Tick is an initiative of the Mobile Manufacturers Forum (MMF). While a product may be considered eligible, use of the SAR Tick logo requires an agreement with the MMF. Further details can be obtained by emailing: sartick@mmfai.info.

FCC ID: A3LSMN915G		SAR EVALUATION REPORT		Reviewed by: Quality Manager
Document S/N: OY1408121709.A3L	Test Dates: 08/14/14 - 08/18/14	DUT Type: Portable Handset	Page 1 of 73	

T A B L E O F C O N T E N T S

1	DEVICE UNDER TEST	3
2	LTE INFORMATION	11
3	INTRODUCTION	12
4	DOSIMETRIC ASSESSMENT	13
5	DEFINITION OF REFERENCE POINTS	14
6	TEST CONFIGURATION POSITIONS FOR HANDSETS	15
7	RF EXPOSURE LIMITS	18
8	FCC MEASUREMENT PROCEDURES.....	19
9	RF CONDUCTED POWERS.....	24
10	SYSTEM VERIFICATION.....	44
11	SAR DATA SUMMARY	47
12	FCC MULTI-TX AND ANTENNA SAR CONSIDERATIONS.....	58
13	SAR MEASUREMENT VARIABILITY	67
14	EQUIPMENT LIST.....	68
15	MEASUREMENT UNCERTAINTIES	69
16	CONCLUSION.....	71
17	REFERENCES	72
APPENDIX A: SAR TEST PLOTS		
APPENDIX B: SAR DIPOLE VERIFICATION PLOTS		
APPENDIX C: PROBE AND DIPOLE CALIBRATION CERTIFICATES		
APPENDIX D: SAR TISSUE SPECIFICATIONS		
APPENDIX E: SAR SYSTEM VALIDATION		
APPENDIX F: SAR TEST SETUP PHOTOGRAPHS		

FCC ID: A3LSMN915G	 <small>PROVIDING EXCELLENCE, INC.</small>	SAR EVALUATION REPORT		Reviewed by: Quality Manager
Document S/N: OY1408121709.A3L	Test Dates: 08/14/14 - 08/18/14	DUT Type: Portable Handset	Page 2 of 73	

1 DEVICE UNDER TEST

1.1 Device Overview



Band & Mode	Operating Modes	Tx Frequency
GSM/GPRS/EDGE 850	Voice/Data	824.20 - 848.80 MHz
GSM/GPRS/EDGE 1900	Voice/Data	1850.20 - 1909.80 MHz
UMTS 850	Voice/Data	826.40 - 846.60 MHz
UMTS 1900	Voice/Data	1852.4 - 1907.6 MHz
LTE Band 5 (Cell)	Voice/Data	824.7 - 848.3 MHz
LTE Band 4 (AWS)	Voice/Data	1710.7 - 1754.3 MHz
LTE Band 2 (PCS)	Voice/Data	1850.7 - 1909.3 MHz
2.4 GHz WLAN	Data	2412 - 2462 MHz
5.8 GHz WLAN	Data	5745 - 5825 MHz
5.2 GHz WLAN	Data	5180 - 5240 MHz
5.3 GHz WLAN	Data	5260 - 5320 MHz
5.5 GHz WLAN	Data	5500 - 5700 MHz
Bluetooth	Data	2402 - 2480 MHz
NFC	Data	13.56 MHz
ANT+	Data	2402 - 2480 MHz

1.2 Nominal and Maximum Output Power Specifications

This device operates using the following maximum and nominal output power specifications. SAR values were scaled to the maximum allowed power to determine compliance per KDB Publication 447498 D01v05.

Mode / Band		Voice (dBm)	Burst Average GMSK (dBm)				Burst Average 8-PSK (dBm)			
			1 TX Slot	1 TX Slots	2 TX Slots	3 TX Slots	4 TX Slots	1 TX Slots	2 TX Slots	3 TX Slots
GSM/GPRS/EDGE 850	Maximum	33.5	33.5	31.0	29.0	28.5	26.0	24.5	23.0	22.5
	Nominal	33.0	33.0	30.5	28.5	28.0	25.5	24.0	22.5	22.0
GSM/GPRS/EDGE 1900	Maximum	30.0	30.0	29.0	27.0	25.5	26.0	24.0	23.0	22.0
	Nominal	29.5	29.5	28.5	26.5	25.0	25.5	23.5	22.5	21.5

Mode / Band		Modulated Average (dBm)			
		3GPP WCDMA Rel 99	3GPP HSDPA Rel 5	3GPP HSUPA Rel 6	3GPP DC-HSDPA Rel 8
UMTS Band 5 (850 MHz)	Maximum	24.0	24.0	23.5	24.0
	Nominal	23.5	23.5	23.0	23.5
UMTS Band 2 (1900 MHz)	Maximum	23.0	23.0	23.0	23.0
	Nominal	22.5	22.5	22.5	22.5

FCC ID: A3LSMN915G	 PCTEST PROVIDING EXCELLENCE,™	SAR EVALUATION REPORT		Reviewed by: Quality Manager
Document S/N: OY1408121709.A3L	Test Dates: 08/14/14 - 08/18/14	DUT Type: Portable Handset		Page 3 of 73



Mode / Band		Modulated Average (dBm)
LTE Band 5 (Cell)	Maximum	23.5
	Nominal	23.0
LTE Band 4 (AWS)	Maximum	23.0
	Nominal	22.5
LTE Band 2 (PCS)	Maximum	23.0
	Nominal	22.5

Antenna 1 and Antenna 2

Mode / Band		Modulated Average (dBm)
IEEE 802.11b (2.4 GHz)	Maximum	17.5
	Nominal	17.0
IEEE 802.11g (2.4 GHz)	Maximum	14.5
	Nominal	14.0
IEEE 802.11n (2.4 GHz)	Maximum	13.5
	Nominal	13.0
IEEE 802.11a (5 GHz)	Maximum	14.5
	Nominal	14.0
IEEE 802.11n (5 GHz, 20 MHz BW)	Maximum	13.5
	Nominal	13.0
IEEE 802.11n (5 GHz, 40 MHz BW)	Maximum	12.5
	Nominal	12.0
IEEE 802.11ac (5 GHz, 80 MHz BW)	Maximum	11.5
	Nominal	11.0
Bluetooth	Maximum	12.0
	Nominal	11.5
Bluetooth LE	Maximum	9.5
	Nominal	9.0

MIMO

Mode / Band		Modulated Average (dBm)
IEEE 802.11n (2.4 GHz)	Maximum	16.5
	Nominal	16.0
IEEE 802.11n (5 GHz, 20 MHz BW)	Maximum	13.5
	Nominal	13.0
IEEE 802.11n (5 GHz, 40 MHz BW)	Maximum	12.0
	Nominal	11.5
IEEE 802.11ac (5 GHz, 80 MHz BW)	Maximum	11.5
	Nominal	11.0

FCC ID: A3LSMN915G	 PCTEST PROTECTING YOUR PRIVACY	SAR EVALUATION REPORT		Reviewed by: Quality Manager
Document S/N: OY1408121709.A3L	Test Dates: 08/14/14 - 08/18/14	DUT Type: Portable Handset		Page 4 of 73

1.3 DUT Antenna Locations

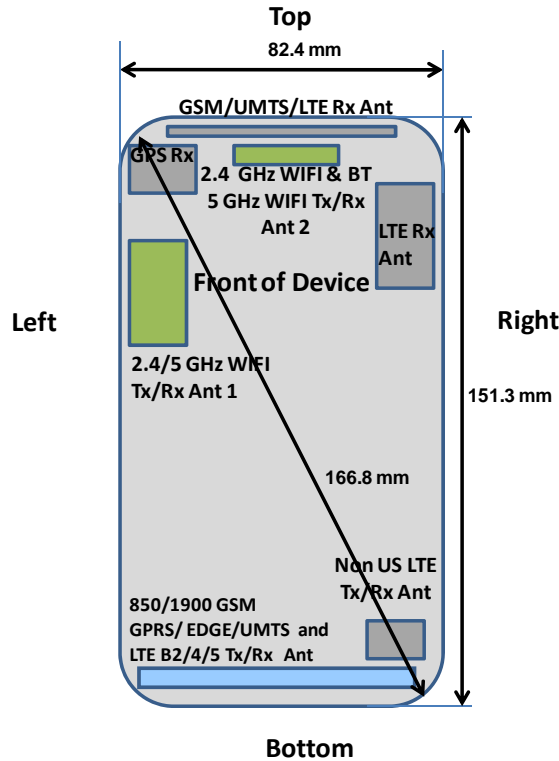

Note: Exact antenna dimensions and separation distances are shown in the Technical Descriptions in the FCC Filing. Since the diagonal dimension of this device is > 160 mm and <200 mm, it is considered a “phablet.”

Figure 1-1
DUT Antenna Locations

Table 1-1
Sides for SAR Testing

Mode	Configuration	Back	Front	Top	Bottom	Right	Left
GPRS 850	Hotspot	Yes	Yes	No	Yes	Yes	Yes
GPRS 1900	Hotspot	Yes	Yes	No	Yes	Yes	Yes
UMTS 850	Hotspot	Yes	Yes	No	Yes	Yes	Yes
UMTS 1900	Hotspot	Yes	Yes	No	Yes	Yes	Yes
LTE Band 5 (Cell)	Hotspot	Yes	Yes	No	Yes	Yes	Yes
LTE Band 4 (AWS)	Hotspot	Yes	Yes	No	Yes	Yes	Yes
LTE Band 2 (PCS)	Hotspot	Yes	Yes	No	Yes	Yes	Yes
2.4 GHz WLAN Ant 1	Hotspot	Yes	Yes	Yes	No	No	Yes
2.4 GHz WLAN Ant 2	Hotspot	Yes	Yes	Yes	No	No	No
2.4 GHz WLAN MIMO	Hotspot	Yes	Yes	Yes	No	No	Yes
5 GHz WLAN Ant 1	Extremity	Yes	Yes	Yes	No	No	Yes
5 GHz WLAN Ant 2	Extremity	Yes	Yes	Yes	No	No	No
5 GHz WLAN MIMO	Extremity	Yes	Yes	Yes	No	No	Yes

Note: Particular DUT edges were not required to be evaluated for Wireless Router SAR or Extremity SAR if the edges were greater than 2.5 cm from the transmitting antenna according to FCC KDB Publication 941225 D06v01 guidance, page 2 and FCC KDB 648474 D04v01r01.

FCC ID: A3LSMN915G	PCTEST PROVIDING UNPRECEDENTED... SAR EVALUATION REPORT		Reviewed by: Quality Manager
Document S/N: OY1408121709.A3L	Test Dates: 08/14/14 - 08/18/14	DUT Type: Portable Handset	Page 5 of 73

1.4 Near Field Communications (NFC) Antenna

This DUT has NFC operations. The NFC antenna is integrated into the specialized battery. The SAR tests were performed with the specialized battery (model: EB-BN915BBE).

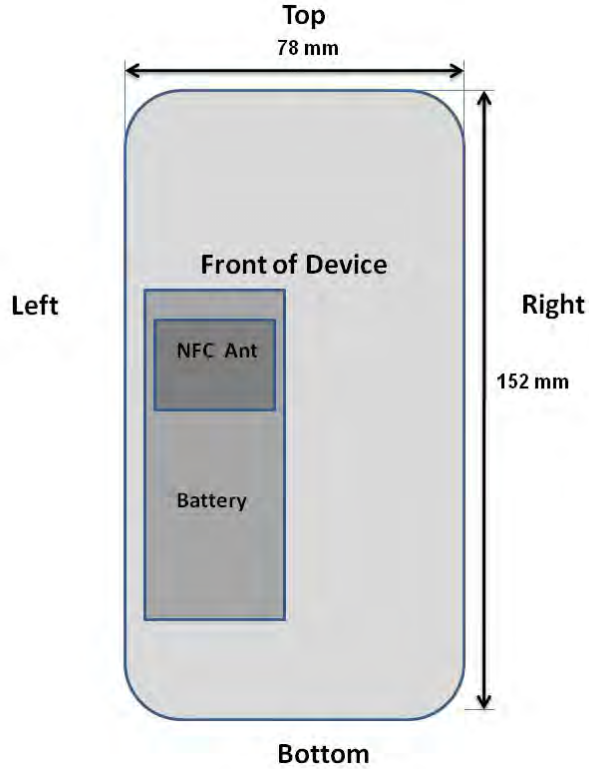



Figure 1-2
NFC Antenna Locations

FCC ID: A3LSMN915G	 PCTEST PROVIDING EXCELLENCE, INC.	SAR EVALUATION REPORT		Reviewed by: Quality Manager
Document S/N: OY1408121709.A3L	Test Dates: 08/14/14 - 08/18/14	DUT Type: Portable Handset	Page 6 of 73	

1.5 Simultaneous Transmission Capabilities

According to FCC KDB Publication 447498 D05v01, transmitters are considered to be transmitting simultaneously when there is overlapping transmission, with the exception of transmissions during network hand-offs with maximum hand-off duration less than 30 seconds. Possible transmission paths for the DUT are shown in Figure 1-3 and are color-coded to indicate communication modes which share the same path. Modes which share the same transmission path cannot transmit simultaneously with one another.

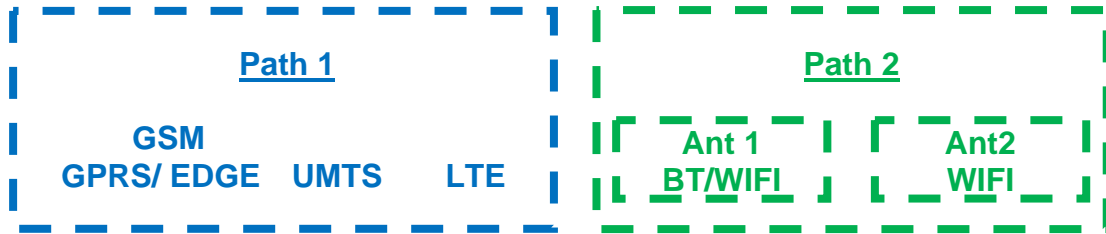



Figure 1-3
Simultaneous Transmission Paths

This device contains multiple transmitters that may operate simultaneously, and therefore requires a simultaneous transmission analysis according to FCC KDB Publication 447498 D01v05 3) procedures.

Table 1-2
Simultaneous Transmission Scenarios

No.	Capable Transmit Configuration	Head	Body-Worn Accessory	Wireless Router	Extremity
1	GSM voice + 2.4 GHz WI-FI	Yes	Yes	N/A	Yes
2	GSM voice + 5 GHz WI-FI	Yes	Yes	N/A	Yes
3	GSM voice + 2.4 GHz Bluetooth	N/A	Yes	N/A	Yes
4	UMTS + 2.4 GHz WI-FI	Yes	Yes	Yes	Yes
5	UMTS + 5 GHz WI-FI	Yes	Yes	N/A	Yes
6	UMTS + 2.4 GHz Bluetooth	N/A	Yes	N/A	Yes
7	LTE + 2.4 GHz WI-FI	Yes	Yes	Yes	Yes
8	LTE + 2.4 GHz Bluetooth	N/A	Yes	N/A	Yes
9	GPRS/EDGE + 2.4 GHz WI-FI	N/A	N/A	Yes	Yes
10	LTE + 5 GHz WI-FI	Yes	Yes	N/A	Yes
11	GPRS/EDGE + 5 GHz WI-FI	N/A	N/A	N/A	Yes

- 2.4 GHz WLAN, 5 GHz WLAN, and 2.4 GHz Bluetooth share the same antenna path and cannot transmit simultaneously.
- All licensed modes share the same antenna path and cannot transmit simultaneously.
- When the user utilizes multiple services in UMTS 3G mode it uses multi-Radio Access Bearer or multi-RAB. The power control is based on a physical control channel (Dedicated Physical Control Channel [DPCCCH]) and power control will be adjusted to meet the needs of both services. Therefore, the UMTS+WLAN scenario also represents the UMTS Voice/DATA + WLAN Hotspot scenario.
- Per the manufacturer, WIFI Direct is not expected to be used in conjunction with a held-to-ear or body-worn accessory voice call. Therefore, there are no simultaneous transmission scenarios involving WIFI direct beyond that listed in the above table.
- When wireless router mode is enabled, all 5GHz bands are disabled.
- This device supports 2x2 MIMO Tx for WLAN 802.11n/ac. Each WLAN antenna can transmit independently or together when operating with MIMO.
- This device supports VoLTE.

FCC ID: A3LSMN915G	 PCTEST ENGINEERING LABORATORY, INC.	SAR EVALUATION REPORT		Reviewed by: Quality Manager
Document S/N: OY1408121709.A3L	Test Dates: 08/14/14 - 08/18/14	DUT Type: Portable Handset		Page 7 of 73

1.6 SAR Test Exclusions Applied

(A) WIFI/BT

Since Wireless Router operations are not allowed by the chipset firmware using 5 GHz WIFI, only 2.4 GHz WIFI Hotspot SAR tests and combinations are considered for SAR with respect to Wireless Router configurations according to FCC KDB 941225 D06v01.

Per FCC KDB 447498 D01v05, the 1g SAR exclusion threshold for distances <50mm is defined by the following equation:

$$\frac{\text{Max Power of Channel (mW)}}{\text{Test Separation Dist (mm)}} * \sqrt{\text{Frequency(GHz)}} \leq 3.0$$

Based on the maximum conducted power of Bluetooth (rounded to the nearest mW) and the antenna to user separation distance, body-worn Bluetooth SAR was not required; $[(16/10) * \sqrt{2.480}] = 2.5 < 3.0$. Per KDB Publication 447498 D01v05, the maximum power of the channel was rounded to the nearest mW before calculation.

Per FCC KDB 447498 D01v05, the 10g SAR exclusion threshold for distances <50mm is defined by the following equation:

$$\frac{\text{Max Power of Channel (mW)}}{\text{Test Separation Dist (mm)}} * \sqrt{\text{Frequency(GHz)}} \leq 7.5$$



Based on the maximum conducted power of Bluetooth (rounded to the nearest mW) and the antenna to user separation distance, extremity Bluetooth SAR was not required; $[(16/5) * \sqrt{2.480}] = 5 < 7.5$. Per KDB Publication 447498 D01v05, the maximum power of the channel was rounded to the nearest mW before calculation.

This device supports 20 MHz and 40 MHz Bandwidths for IEEE 802.11n for 5 GHz WIFI only. IEEE 802.11n was not evaluated for SAR since the average output power of 20 MHz and 40 MHz bandwidths was not more than 0.25 dB higher than the average output power of IEEE 802.11a.

This device supports IEEE 802.11ac with the following features:

- a) Up to 80 MHz Bandwidth only
- b) No aggregate channel configurations
- c) 2 Tx antenna output
- d) 256 QAM is supported
- e) No new 5 GHz channels

Per FCC KDB Publication 648474 D04v01r01, this device is considered a "phablet" since the diagonal dimension is greater than 160mm and less than 200mm. Extremity SAR tests are required when wireless router mode does not apply or if wireless router 1g SAR > 1.2 W/kg. Because wireless router operations are not supported for 5 GHz WLAN, extremity SAR tests were performed. Extremity SAR was not evaluated for 2.4 GHz WLAN operations since wireless router 1g SAR was < 1.2 W/kg.

FCC ID: A3LSMN915G	 PCTEST ENGINEERING LABORATORY, INC.	SAR EVALUATION REPORT		Reviewed by: Quality Manager
Document S/N: OY1408121709.A3L	Test Dates: 08/14/14 - 08/18/14	DUT Type: Portable Handset	Page 8 of 73	

(B) Licensed Transmitter(s)

GSM/GPRS/EDGE DTM is not supported for US bands. Therefore, the GSM Voice modes in this report do not transmit simultaneously with GPRS/EDGE Data.

This device is only capable of QPSK HSUPA in the uplink. Therefore, no additional SAR tests are required beyond that described for devices with HSUPA in KDB 941225 D01v02.

LTE SAR for the higher modulations and lower bandwidths were not tested since the maximum average output power of all required channels and configurations was not more than 0.5 dB higher than the highest bandwidth; and the reported LTE SAR for the highest bandwidth was less than 1.45 W/kg for all configurations according to FCC KDB 941225 D05v02.

Per FCC KDB Publication 648474 D04v01r01, this device is considered a "phablet" since the diagonal dimension is greater than 160mm and less than 200mm. Therefore, extremity SAR tests are required when wireless router mode does not apply or if wireless router 1g SAR > 1.2 W/kg. Extremity SAR was not evaluated for licensed technologies since wireless router 1g SAR was < 1.2 W/kg for these modes.

1.7 Power Reduction for SAR



There is no power reduction used for any band/mode implemented in this device for SAR purposes.

1.8 Guidance Applied



- IEEE 1528-2003
- FCC KDB Publication 941225 D01v02, D02v02r02, D03v01, D05v02r03, D06v01r01 (2G/3G/4G and Hotspot)
- FCC KDB Publication 248227 D01v01r02 (SAR Considerations for 802.11 Devices)
- FCC KDB Publication 447498 D01v05r02 (General SAR Guidance)
- FCC KDB Publication 865664 D01v01r03, D02v01r01 (SAR Measurements up to 6 GHz)
- FCC KDB Publication 648474 D03-D04 (Phablet Procedures)
- April 2013 TCB Workshop Notes (IEEE 802.11ac)
- October 2013 TCB Workshop Notes (GPRS Testing Considerations)

1.9 Device Serial Numbers

Several samples were used with identical hardware to support SAR testing. The manufacturer has confirmed that the device(s) tested have the same physical, mechanical and thermal characteristics and are within operational tolerances expected for production units.

FCC ID: A3LSMN915G	 PCTEST ENGINEERING LABORATORY, INC.	SAR EVALUATION REPORT		Reviewed by: Quality Manager
Document S/N: OY1408121709.A3L	Test Dates: 08/14/14 - 08/18/14	DUT Type: Portable Handset	Page 9 of 73	



	Head Serial Number	Body-Worn Serial Number	Hotspot Serial Number	Extremity Serial Number
GSM/GPRS/EDGE 850	F238A	F238A	F238A	-
GSM/GPRS/EDGE 1900	F227C	F238A	F238A	-
UMTS 850	F227C	F227C	F227C	-
UMTS 1900	F227C	F227C	F227C	-
LTE Band 5 (Cell)	F238A	F238A	F238A	-
LTE Band 4 (AWS)	F238A	F238A	F238A	-
LTE Band 2 (PCS)	F227C	F227C	F227C	-
2.4 GHz WLAN	F2279	F2279	F2279	-
5 GHz WLAN	F238A	F227C	-	F227C

FCC ID: A3LSMN915G	 PCTEST PROVIDING SOLUTIONS, INC.	SAR EVALUATION REPORT		Reviewed by: Quality Manager
Document S/N: OY1408121709.A3L	Test Dates: 08/14/14 - 08/18/14	DUT Type: Portable Handset	Page 10 of 73	

2

LTE INFORMATION

LTE Information			
FCC ID	A3LSMN915G		
Form Factor	Portable Handset		
Frequency Range of each LTE transmission band	LTE Band 5 (Cell) (824.7 - 848.3 MHz)		
	LTE Band 4 (AWS) (1710.7 - 1754.3 MHz)		
	LTE Band 2 (PCS) (1850.7 - 1909.3 MHz)		
Channel Bandwidths	LTE Band 5 (Cell): 1.4 MHz, 3 MHz, 5 MHz, 10 MHz		
	LTE Band 4 (AWS): 1.4 MHz, 3 MHz, 5 MHz, 10 MHz, 15 MHz, 20 MHz		
	LTE Band 2 (PCS): 1.4 MHz, 3 MHz, 5 MHz, 10 MHz, 15 MHz, 20 MHz		
Channel Numbers and Frequencies (MHz)	Low	Mid	High
LTE Band 5 (Cell): 1.4 MHz	824.7 (20407)	836.5 (20525)	848.3 (20643)
LTE Band 5 (Cell): 3 MHz	825.5 (20415)	836.5 (20525)	847.5 (20635)
LTE Band 5 (Cell): 5 MHz	826.5 (20425)	836.5 (20525)	846.5 (20625)
LTE Band 5 (Cell): 10 MHz	829 (20450)	836.5 (20525)	844 (20600)
LTE Band 4 (AWS): 1.4 MHz	1710.7 (19957)	1732.5 (20175)	1754.3 (20393)
LTE Band 4 (AWS): 3 MHz	1711.5 (19965)	1732.5 (20175)	1753.5 (20385)
LTE Band 4 (AWS): 5 MHz	1712.5 (19975)	1732.5 (20175)	1752.5 (20375)
LTE Band 4 (AWS): 10 MHz	1715 (20000)	1732.5 (20175)	1750 (20350)
LTE Band 4 (AWS): 15 MHz	1717.5 (20025)	1732.5 (20175)	1747.5 (20325)
LTE Band 4 (AWS): 20 MHz	1720 (20050)	1732.5 (20175)	1745 (20300)
LTE Band 2 (PCS): 1.4 MHz	1850.7 (18607)	1880 (18900)	1909.3 (19193)
LTE Band 2 (PCS): 3 MHz	1851.5 (18615)	1880 (18900)	1908.5 (19185)
LTE Band 2 (PCS): 5 MHz	1852.5 (18625)	1880 (18900)	1907.5 (19175)
LTE Band 2 (PCS): 10 MHz	1855 (18650)	1880 (18900)	1905 (19150)
LTE Band 2 (PCS): 15 MHz	1857.5 (18675)	1880 (18900)	1902.5 (19125)
LTE Band 2 (PCS): 20 MHz	1860 (18700)	1880 (18900)	1900 (19100)
UE Category	6		
Modulations Supported in UL	QPSK, 16QAM		
LTE MPR Permanently implemented per 3GPP TS 36.101 section 6.2.3-6.2.5? (manufacturer attestation to be provided)	YES		
A-MPR (Additional MPR) disabled for SAR Testing?	YES		

FCC ID: A3LSMN915G	 PCTEST PROVIDING EXCELLENCE, 36	SAR EVALUATION REPORT	 SAMSUNG	Reviewed by: Quality Manager
Document S/N: OY1408121709.A3L	Test Dates: 08/14/14 - 08/18/14	DUT Type: Portable Handset	Page 11 of 73	

3 INTRODUCTION

The FCC and Industry Canada have adopted the guidelines for evaluating the environmental effects of radio frequency (RF) radiation in ET Docket 93-62 on Aug. 6, 1996 and Health Canada Safety Code 6 to protect the public and workers from the potential hazards of RF emissions due to FCC-regulated portable devices. [1]

The safety limits used for the environmental evaluation measurements are based on the criteria published by the American National Standards Institute (ANSI) for localized specific absorption rate (SAR) in IEEE/ANSI C95.1-1992 Standard for Safety Levels with Respect to Human Exposure to Radio Frequency Electromagnetic Fields, 3 kHz to 300 GHz [3] and Health Canada RF Exposure Guidelines Safety Code 6 [22]. The measurement procedure described in IEEE/ANSI C95.3-2002 Recommended Practice for the Measurement of Potentially Hazardous Electromagnetic Fields - RF and Microwave [4] is used for guidance in measuring the Specific Absorption Rate (SAR) due to the RF radiation exposure from the Equipment Under Test (EUT). These criteria for SAR evaluation are similar to those recommended by the International Committee for Non-Ionizing Radiation Protection (ICNIRP) in Biological Effects and Exposure Criteria for Radiofrequency Electromagnetic Fields," Report No. Vol 74. SAR is a measure of the rate of energy absorption due to exposure to an RF transmitting source. SAR values have been related to threshold levels for potential biological hazards.

3.1 SAR Definition

Specific Absorption Rate is defined as the time derivative (rate) of the incremental energy (dU) absorbed by (dissipated in) an incremental mass (dm) contained in a volume element (dV) of a given density (ρ). It is also defined as the rate of RF energy absorption per unit mass at a point in an absorbing body (see Equation 3-1).

**Equation 3-1
SAR Mathematical Equation**

$$SAR = \frac{d}{dt} \left(\frac{dU}{dm} \right) = \frac{d}{dt} \left(\frac{dU}{\rho dv} \right)$$



SAR is expressed in units of Watts per Kilogram (W/kg).

$$SAR = \frac{\sigma \cdot E^2}{\rho}$$

where:

- σ = conductivity of the tissue-simulating material (S/m)
- ρ = mass density of the tissue-simulating material (kg/m³)
- E = Total RMS electric field strength (V/m)

NOTE: The primary factors that control rate of energy absorption were found to be the wavelength of the incident field in relation to the dimensions and geometry of the irradiated organism, the orientation of the organism in relation to the polarity of field vectors, the presence of reflecting surfaces, and whether conductive contact is made by the organism with a ground plane.[6]

FCC ID: A3LSMN915G	 PCTEST ENGINEERING LABORATORY, INC.	SAR EVALUATION REPORT		Reviewed by: Quality Manager
Document S/N: OY1408121709.A3L	Test Dates: 08/14/14 - 08/18/14	DUT Type: Portable Handset	Page 12 of 73	

4 DOSIMETRIC ASSESSMENT

4.1 Measurement Procedure

The evaluation was performed using the following procedure compliant to FCC KDB Publication 865664 D01v01 and IEEE 1528-2013:

1. The SAR distribution at the exposed side of the head or body was measured at a distance no greater than 5.0 mm from the inner surface of the shell. The area covered the entire dimension of the device-head and body interface and the horizontal grid resolution was determined per FCC KDB Publication 865664 D01v01 (See Table 4-1) and IEEE 1528-2013.
2. The point SAR measurement was taken at the maximum SAR region determined from Step 1 to enable the monitoring of SAR fluctuations/drifts during the 1g/10g cube evaluation. SAR at this fixed point was measured and used as a reference value.
3. Based on the area scan data, the peak of the region with maximum SAR was determined by spline interpolation. Around this point, a volume was assessed according to the measurement resolution and volume size requirements of FCC KDB Publication 865664 D01v01 (See Table 4-1) and IEEE 1528-2013. On the basis of this data set, the spatial peak SAR value was evaluated with the following procedure (see references or the DASYS manual online for more details):
 - a. SAR values at the inner surface of the phantom are extrapolated from the measured values along the line away from the surface with spacing no greater than that in Table 4-1. The extrapolation was based on a least-squares algorithm. A polynomial of the fourth order was calculated through the points in the z-axis (normal to the phantom shell).
 - b. After the maximum interpolated values were calculated between the points in the cube, the SAR was averaged over the spatial volume (1g or 10g) using a 3D-Spline interpolation algorithm. The 3D-spline is composed of three one-dimensional splines with the “Not a knot” condition (in x, y, and z directions). The volume was then integrated with the trapezoidal algorithm. One thousand points (10 x 10 x 10) were obtained through interpolation, in order to calculate the averaged SAR.
 - c. All neighboring volumes were evaluated until no neighboring volume with a higher average value was found.
4. The SAR reference value, at the same location as step 2, was re-measured after the zoom scan was complete to calculate the SAR drift. If the drift deviated by more than 5%, the SAR test and drift measurements were repeated.

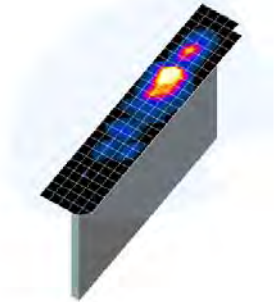



Figure 4-1
Sample SAR Area Scan

Table 4-1
Area and Zoom Scan Resolutions per FCC KDB Publication 865664 D01v01*

Frequency	Maximum Area Scan Resolution (mm) ($\Delta x_{area}, \Delta y_{area}$)	Maximum Zoom Scan Resolution (mm) ($\Delta x_{zoom}, \Delta y_{zoom}$)	Maximum Zoom Scan Spatial Resolution (mm)			Minimum Zoom Scan Volume (mm) (x,y,z)
			Uniform Grid $\Delta z_{zoom}(n)$	Graded Grid		
				$\Delta z_{zoom}(1)^*$	$\Delta z_{zoom}(n>1)^*$	
≤ 2 GHz	≤ 15	≤ 8	≤ 5	≤ 4	≤ 1.5* $\Delta z_{zoom}(n-1)$	≥ 30
2-3 GHz	≤ 12	≤ 5	≤ 5	≤ 4	≤ 1.5* $\Delta z_{zoom}(n-1)$	≥ 30
3-4 GHz	≤ 12	≤ 5	≤ 4	≤ 3	≤ 1.5* $\Delta z_{zoom}(n-1)$	≥ 28
4-5 GHz	≤ 10	≤ 4	≤ 3	≤ 2.5	≤ 1.5* $\Delta z_{zoom}(n-1)$	≥ 25
5-6 GHz	≤ 10	≤ 4	≤ 2	≤ 2	≤ 1.5* $\Delta z_{zoom}(n-1)$	≥ 22

*Also compliant to IEEE 1528-2013 Table 6

FCC ID: A3LSMN915G		SAR EVALUATION REPORT		Reviewed by: Quality Manager
Document S/N: OY1408121709.A3L	Test Dates: 08/14/14 - 08/18/14	DUT Type: Portable Handset	Page 13 of 73	

5 DEFINITION OF REFERENCE POINTS

5.1 EAR REFERENCE POINT

Figure 5-2 shows the front, back and side views of the SAM Twin Phantom. The point “M” is the reference point for the center of the mouth, “LE” is the left ear reference point (ERP), and “RE” is the right ERP. The ERP is 15mm posterior to the entrance to the ear canal (EEC) along the B-M line (Back-Mouth), as shown in Figure 5-1. The plane passing through the two ear canals and M is defined as the Reference Plane. The line N-F (Neck-Front), also called the Reference Pivoting Line, is not perpendicular to the reference plane (see Figure 5-1). Line B-M is perpendicular to the N-F line. Both N-F and B-M lines are marked on the external phantom shell to facilitate handset positioning [5].

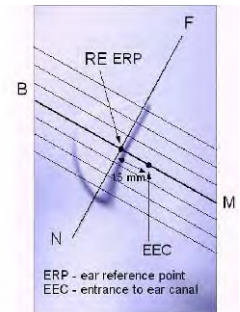

Figure 5-1
Close-Up Side view of ERP

5.2 HANDSET REFERENCE POINTS

Two imaginary lines on the handset were established: the vertical centerline and the horizontal line. The test device was placed in a normal operating position with the acoustic output located along the “vertical centerline” on the front of the device aligned to the “ear reference point” (See Figure 5-3). The acoustic output was then located at the same level as the center of the ear reference point. The test device was positioned so that the “vertical centerline” was bisecting the front surface of the handset at its top and bottom edges, positioning the “ear reference point” on the outer surface of the both the left and right head phantoms on the ear reference point.



Figure 5-2
Front, back and side view of SAM Twin Phantom

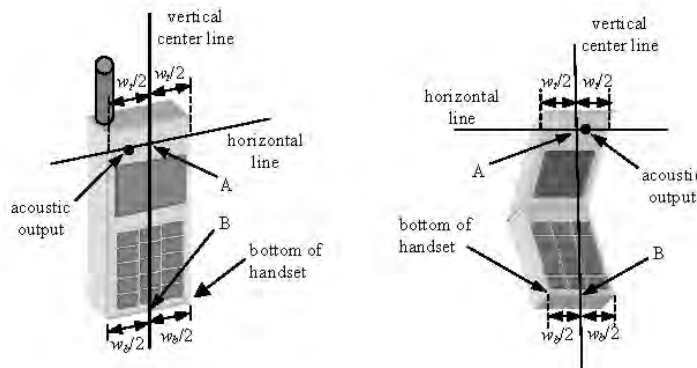



Figure 5-3
Handset Vertical Center & Horizontal Line Reference Points

FCC ID: A3LSMN915G		SAR EVALUATION REPORT		Reviewed by: Quality Manager
Document S/N: OY1408121709.A3L	Test Dates: 08/14/14 - 08/18/14	DUT Type: Portable Handset		Page 14 of 73

6 TEST CONFIGURATION POSITIONS FOR HANDSETS

6.1 Device Holder

The device holder is made out of low-loss POM material having the following dielectric parameters: relative permittivity $\epsilon = 3$ and loss tangent $\delta = 0.02$.

6.2 Positioning for Cheek

1. The test device was positioned with the device close to the surface of the phantom such that point A is on the (virtual) extension of the line passing through points RE and LE on the phantom (see Figure 6-1), such that the plane defined by the vertical center line and the horizontal line of the phone is approximately parallel to the sagittal plane of the phantom.

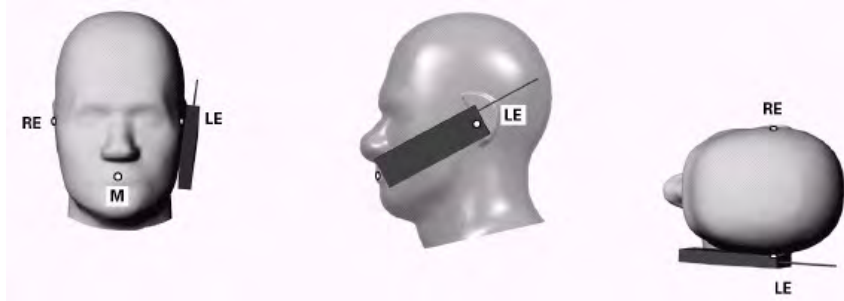



Figure 6-1 Front, Side and Top View of Cheek Position

2. The handset was translated towards the phantom along the line passing through RE & LE until the handset touches the pinna.
3. While maintaining the handset in this plane, the handset was rotated around the LE-RE line until the vertical centerline was in the reference plane.
4. The phone was then rotated around the vertical centerline until the phone (horizontal line) was symmetrical with respect to the line NF.
5. While maintaining the vertical centerline in the reference plane, keeping point A on the line passing through RE and LE, and maintaining the device contact with the ear, the device was rotated about the NF line until any point on the handset made contact with a phantom point below the ear (cheek) (See Figure 6-2).

6.3 Positioning for Ear / 15° Tilt

With the test device aligned in the “Cheek Position”:

1. While maintaining the orientation of the phone, the phone was retracted parallel to the reference plane far enough to enable a rotation of the phone by 15 degrees.
2. The phone was then rotated around the horizontal line by 15 degrees.
3. While maintaining the orientation of the phone, the phone was moved parallel to the reference plane until any part of the handset touched the head. (In this position, point A was located on the line RE-LE). The tilted position is obtained when the contact is on the pinna. If the contact was at any location other than the pinna, the angle of the phone would then be reduced. In this situation, the tilted position was obtained when any part of the phone was in contact of the ear as well as a second part of the phone was in contact with the head (see Figure 6-2).

FCC ID: A3LSMN915G	 PCTEST PROTECTING UNEXPOSED	SAR EVALUATION REPORT	 SAMSUNG	Reviewed by: Quality Manager
Document S/N: OY1408121709.A3L	Test Dates: 08/14/14 - 08/18/14	DUT Type: Portable Handset		Page 15 of 73

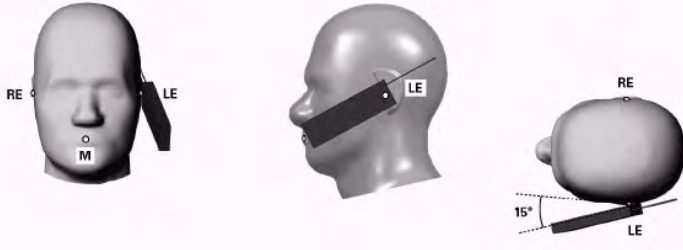

Figure 6-2 Front, Side and Top View of Ear/15° Tilt Position

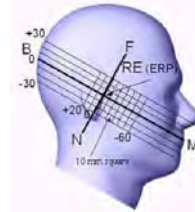

Figure 6-3 Side view w/ relevant markings

6.4 SAR Evaluations near the Mouth/Jaw Regions of the SAM Phantom

Antennas located near the bottom of a phone may require SAR measurements around the mouth and jaw regions of the SAM head phantom. This typically applies to clam-shell style phones that are generally longer in the unfolded normal use positions or to certain older style long rectangular phones. Per IEEE 1528-2013, a rotated SAM phantom is necessary to allow probe access to such regions. Both SAM heads of the TwinSAM-Chin20 are rotated 20 degrees around the NF line. Each head can be removed from the table for emptying and cleaning.

Under these circumstances, the following procedures apply, adopted from the FCC guidance on SAR handsets document FCC KDB Publication 648474 D04_v01. The SAR required in these regions of SAM should be measured using a flat phantom. The phone should be positioned with a separation distance of 4 mm between the ear reference point (ERP) and the outer surface of the flat phantom shell. While maintaining this distance at the ERP location, the low (bottom) edge of the phone should be lowered from the phantom to establish the same separation distance between the peak SAR location identified by the truncated partial SAR distribution measured with the SAM phantom. The distance from the peak SAR location to the phone is determined by the straight line passing perpendicularly through the phantom surface. When it is not feasible to maintain 4 mm separation at the ERP while also establishing the required separation at the peak SAR location, the top edge of the phone will be allowed to touch the phantom with a separation < 4 mm at the ERP. The phone should not be tilted to the left or right while placed in this inclined position to the flat phantom.

6.5 Body-Worn Accessory Configurations

Body-worn operating configurations are tested with the belt-clips and holsters attached to the device and positioned against a flat phantom in a normal use configuration (see Figure 6-4). Per FCC KDB Publication 648474 D04v01, Body-worn accessory exposure is typically related to voice mode operations when handsets are carried in body-worn accessories. The body-worn accessory procedures in FCC KDB Publication 447498 D01v05 should be used to test for body-worn accessory SAR compliance, without a headset connected to it. This enables the test results for such configuration to be compatible with that required for hotspot mode when the body-worn accessory test separation distance is greater than or equal to that required for hotspot mode, when applicable. When the reported SAR for a body-worn accessory, measured without a headset connected to the handset, is > 1.2 W/kg, the highest reported SAR configuration for that wireless mode and frequency band should be repeated for that body-worn accessory with a headset attached to the handset.

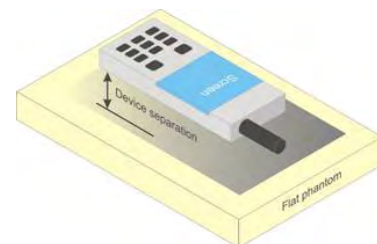



Figure 6-4 Sample Body-Worn Diagram

Accessories for Body-worn operation configurations are divided into two categories: those that do not contain metallic components and those that do contain metallic components. When multiple accessories that do not contain metallic components are supplied with the device, the device is tested with only the

FCC ID: A3LSMN915G		SAR EVALUATION REPORT		Reviewed by: Quality Manager
Document S/N: OY1408121709.A3L	Test Dates: 08/14/14 - 08/18/14	DUT Type: Portable Handset		Page 16 of 73

accessory that dictates the closest spacing to the body. Then multiple accessories that contain metallic components are tested with the device with each accessory. If multiple accessories share an identical metallic component (i.e. the same metallic belt-clip used with different holsters with no other metallic components) only the accessory that dictates the closest spacing to the body is tested.

Body-worn accessories may not always be supplied or available as options for some devices intended to be authorized for body-worn use. In this case, a test configuration with a separation distance between the back of the device and the flat phantom is used. Test position spacing was documented. Transmitters that are designed to operate in front of a person's face, as in push-to-talk configurations, are tested for SAR compliance with the front of the device positioned to face the flat phantom in head fluid. For devices that are carried next to the body such as a shoulder, waist or chest-worn transmitters, SAR compliance is tested with the accessories, including headsets and microphones, attached to the device and positioned against a flat phantom in a normal use configuration.

6.6 Extremity Exposure Configurations



Devices that are designed or intended for use on extremities or mainly operated in extremity only exposure conditions; i.e., hands, wrists, feet and ankles, may require extremity SAR evaluation. When the device also operates in close proximity to the user's body, SAR compliance for the body is also required. The 1-g body and 10-g extremity SAR Exclusion Thresholds found in KDB Publication 44798 D01v05 should be applied to determine SAR test requirements.

For smart phones with a display diagonal dimension > 15.0 cm or an overall diagonal dimension > 16.0 cm that provide similar mobile web access and multimedia support found in mini-tablets or UMPC minitabets that support voice calls next to the ear, the phablets procedures outlined in KDB Publication 648474 D04 v01r01DR04 should be applied to evaluate SAR compliance. A device marketed as phablets, regardless of form factors and operating characteristics must be tested as a phablet to determine SAR compliance. In addition to the normally required head and body-worn accessory SAR test procedures required for handsets, the UMPC mini-tablet procedures must also be applied to test the SAR of all surfaces and edges with an antenna ≤ 25 mm from that surface or edge, in direct contact with the phantom, for 10-g SAR. The UMPC mini-tablet 1-g SAR at 5 mm is not required. When hotspot mode applies, 10-g SAR is required only for the surfaces and edges with hotspot mode 1-g SAR > 1.2 W/kg.

6.7 Wireless Router Configurations

Some battery-operated handsets have the capability to transmit and receive user data through simultaneous transmission of WIFI simultaneously with a separate licensed transmitter. The FCC has provided guidance in FCC KDB Publication 941225 D06 v01 where SAR test considerations for handsets ($L \times W \geq 9 \text{ cm} \times 5 \text{ cm}$) are based on a composite test separation distance of 10 mm from the front, back and edges of the device containing transmitting antennas within 2.5 cm of their edges, determined from general mixed use conditions for this type of devices. Since the hotspot SAR results may overlap with the body-worn accessory SAR requirements, the more conservative configurations can be considered, thus excluding some body-worn accessory SAR tests.

When the user enables the personal wireless router functions for the handset, actual operations include simultaneous transmission of both the WIFI transmitter and another licensed transmitter. Both transmitters often do not transmit at the same transmitting frequency and thus cannot be evaluated for SAR under actual use conditions due to the limitations of the SAR assessment probes. Therefore, SAR must be evaluated for each frequency transmission and mode separately and spatially summed with the WIFI transmitter according to FCC KDB Publication 447498 D01v05 publication procedures. The "Portable Hotspot" feature on the handset was NOT activated during SAR assessments, to ensure the SAR measurements were evaluated for a single transmission frequency RF signal at a time.

FCC ID: A3LSMN915G	 PCTEST Engineering Laboratory, Inc.	SAR EVALUATION REPORT		Reviewed by: Quality Manager
Document S/N: OY1408121709.A3L	Test Dates: 08/14/14 - 08/18/14	DUT Type: Portable Handset	Page 17 of 73	

7 RF EXPOSURE LIMITS

7.1 Uncontrolled Environment

UNCONTROLLED ENVIRONMENTS are defined as locations where there is the exposure of individuals who have no knowledge or control of their exposure. The general population/uncontrolled exposure limits are applicable to situations in which the general public may be exposed or in which persons who are exposed as a consequence of their employment may not be made fully aware of the potential for exposure or cannot exercise control over their exposure. Members of the general public would come under this category when exposure is not employment-related; for example, in the case of a wireless transmitter that exposes persons in its vicinity.



7.2 Controlled Environment

CONTROLLED ENVIRONMENTS are defined as locations where there is exposure that may be incurred by persons who are aware of the potential for exposure, (i.e. as a result of employment or occupation). In general, occupational/controlled exposure limits are applicable to situations in which persons are exposed as a consequence of their employment, who have been made fully aware of the potential for exposure and can exercise control over their exposure. This exposure category is also applicable when the exposure is of a transient nature due to incidental passage through a location where the exposure levels may be higher than the general population/uncontrolled limits, but the exposed person is fully aware of the potential for exposure and can exercise control over his or her exposure by leaving the area or by some other appropriate means.

**Table 7-1
SAR Human Exposure Specified in ANSI/IEEE C95.1-1992 and Health Canada Safety Code 6**

HUMAN EXPOSURE LIMITS		
	UNCONTROLLED ENVIRONMENT <i>General Population</i> (W/kg) or (mW/g)	CONTROLLED ENVIRONMENT <i>Occupational</i> (W/kg) or (mW/g)
Peak Spatial Average SAR Head	1.6	8.0
Whole Body SAR	0.08	0.4
Peak Spatial Average SAR Hands, Feet, Ankle, Wrists, etc.	4.0	20

1. The Spatial Peak value of the SAR averaged over any 1 gram of tissue (defined as a tissue volume in the shape of a cube) and over the appropriate averaging time.
2. The Spatial Average value of the SAR averaged over the whole body.
3. The Spatial Peak value of the SAR averaged over any 10 grams of tissue (defined as a tissue volume in the shape of a cube) and over the appropriate averaging time.

FCC ID: A3LSMN915G	 PCTEST PROVIDING EXCELLENCE™	SAR EVALUATION REPORT		Reviewed by: Quality Manager
Document S/N: OY1408121709.A3L	Test Dates: 08/14/14 - 08/18/14	DUT Type: Portable Handset		Page 18 of 73

8 FCC MEASUREMENT PROCEDURES

Power measurements were performed using a base station simulator under digital average power.

8.1 Measured and Reported SAR

Per FCC KDB Publication 447498 D01v05, When SAR is not measured at the maximum power level allowed for production units, the results must be scaled to the maximum tune-up tolerance limit according to the power applied to the individual channels tested to determine compliance. For simultaneous transmission, the measured aggregate SAR must be scaled according to the sum of the differences between the maximum tune-up tolerance and actual power used to test each transmitter. When SAR is measured at or scaled to the maximum tune-up tolerance limit, the results are referred to as *reported* SAR. The highest *reported* SAR results are identified on the grant of equipment authorization according to procedures in KDB 690783 D01v01r02.

8.2 Procedures Used to Establish RF Signal for SAR

The following procedures are according to FCC KDB Publication 941225 D01 "SAR Measurement Procedures for 3G Devices" v02, October 2007.

The device was placed into a simulated call using a base station simulator in a RF shielded chamber. Establishing connections in this manner ensure a consistent means for testing SAR and are recommended for evaluating SAR [4]. Devices under test were evaluated prior to testing, with a fully charged battery and were configured to operate at maximum output power. In order to verify that the device was tested throughout the SAR test at maximum output power, the SAR measurement system measures a "point SAR" at an arbitrary reference point at the start and end of the 1 gram SAR evaluation, to assess for any power drifts during the evaluation. If the power drift deviated by more than 5%, the SAR test and drift measurements were repeated.

8.3 SAR Measurement Conditions for UMTS



8.3.1 Output Power Verification

Maximum output power is measured on the High, Middle and Low channels for each applicable transmission band according to the general descriptions in section 5.2 of 3GPP TS 34.121, using the appropriate RMC or AMR with TPC (transmit power control) set to all "1s".

Maximum output power is verified on the High, Middle and Low channels according to the general descriptions in section 5.2 of 3GPP TS 34.121 (release 5), using the appropriate RMC with TPC (transmit power control) set to all "1s" or applying the required inner loop power control procedures to maintain maximum output power while HSUPA is active. Results for all applicable physical channel configurations (DPCCH, DPDCHn and spreading codes, HS-DPCCH etc) are tabulated in this test report. All configurations that are not supported by the DUT or cannot be measured due to technical or equipment limitations are identified.

8.3.2 Head SAR Measurements for Handsets

SAR for head exposure configurations is measured using the 12.2 kbps RMC with TPC bits configured to all "1s". SAR in AMR configurations is not required when the maximum average output of each RF channel for 12.2 kbps AMR is less than 0.25 dB higher than that measured in 12.2 kbps RMC. Otherwise, SAR is measured on the maximum output channel in 12.2 AMR with a

FCC ID: A3LSMN915G	 PCTEST Engineering Laboratory, Inc.	SAR EVALUATION REPORT		Reviewed by: Quality Manager
Document S/N: OY1408121709.A3L	Test Dates: 08/14/14 - 08/18/14	DUT Type: Portable Handset		Page 19 of 73

3.4 kbps SRB (signaling radio bearer) using the exposure configuration that resulted in the highest SAR for that RF channel in the 12.2 kbps RMC mode.

8.3.3 Body SAR Measurements

SAR for body exposure configurations is measured using the 12.2 kbps RMC with the TPC bits all “1s”.

8.3.4 SAR Measurements for Handsets with Rel 5 HSDPA

Body SAR for HSDPA is not required for handsets with HSDPA capabilities when the maximum average output power of each RF channel with HSDPA active is less than 0.25 dB higher than that measured without HSDPA using 12.2 kbps RMC and the maximum SAR for 12.2 kbps RMC is $\leq 75\%$ of the SAR limit. Otherwise, SAR is measured for HSDPA, using an FRC with H-Set 1 in Sub-test 1 and a 12.2 kbps RMC configured in Test Loop Mode 1, using the highest body SAR configuration measured in 12.2 kbps RMC without HSDPA, on the maximum output channel with the body exposure configuration that resulted in the highest SAR in 12.2 kbps RMC mode for that RF channel.

The H-set used in FRC for HSDPA should be configured according to the UE category of a test device. The number of HS-DSCH/HSPDSCHs, HARQ processes, minimum inter-TTI interval, transport block sizes and RV coding sequence are defined by the applicable H-set. To maintain a consistent test configuration and stable transmission conditions, QPSK is used in the FRC for SAR testing. HS-DPCCH should be configured with a CQI feedback cycle of 2 ms to maintain a constant rate of active CQI slots. DPCCH and DPDCH gain factors of $\beta_c=9$ and $\beta_d=15$, and power offset parameters of $\Delta_{ACK}=\Delta_{NACK}=5$ and $\Delta_{CQI}=2$ is used. The CQI value is determined by the UE category, transport block size, number of HS-PDSCHs and modulation used in the FRC.



Sub-Test	β_c	β_d	β_d (SF)	β_c/β_d	β_{HS} (Note 1, Note 2)	CM (dB) (Note 3)	MPR (dB) (Note 3)
1	2/15	15/15	64	2/15	4/15	0.0	0.0
2	12/15 (Note 4)	15/15 (Note 4)	64	12/15 (Note 4)	24/15	1.0	0.0
3	15/15	8/15	64	15/8	30/15	1.5	0.5
4	15/15	4/15	64	15/4	30/15	1.5	0.5

Note 1: Δ_{ACK} , Δ_{NACK} and $\Delta_{CQI} = 8 \Leftrightarrow A_{HS} = \beta_{HS}/\beta_c = 30/15 \Leftrightarrow \beta_{HS} = 30/15 * \beta_c$.
 Note 2: For the HS-DPCCH power mask requirement test in clause 5.2C, 5.7A, and the Error Vector Magnitude (EVM) with HS-DPCCH test in clause 5.13.1A, and HSDPA EVM with phase discontinuity in clause 5.13.1AA, Δ_{ACK} and $\Delta_{NACK} = 8$ ($A_{HS} = 30/15$) with $\beta_{HS} = 30/15 * \beta_c$, and $\Delta_{CQI} = 7$ ($A_{HS} = 24/15$) with $\beta_{HS} = 24/15 * \beta_c$.
 Note 3: CM = 1 for $\beta_c/\beta_d=12/15$, $\beta_{HS}/\beta_c=24/15$. For all other combinations of DPDCH, DPCCH and HS-DPCCH the MPR is based on the relative CM difference. This is applicable for only UEs that support HSDPA in release 6 and later releases.

Figure 8-1
Table C.10.1.4 of TS 234.121-1

8.3.5 SAR Measurements for Handsets with Rel 6 HSUPA

Body SAR for HSUPA is not required when the maximum average output of each RF channel with HSUPA/HSDPA active is less than 0.25 dB higher than as measured without HSUPA/HSDPA using 12.2 kbps RMC and maximum SAR for 12.2 kbps RMC is $\leq 75\%$ of the SAR limit. Otherwise SAR is measured on the maximum output channel for the body exposure configuration produced highest SAR in 12.2 kbps RMC for that RF channel, using the additional procedures under “Release 6 HSPA data devices”

FCC ID: A3LSMN915G		SAR EVALUATION REPORT		Reviewed by: Quality Manager
Document S/N: OY1408121709.A3L	Test Dates: 08/14/14 - 08/18/14	DUT Type: Portable Handset		Page 20 of 73

Head SAR for VOIP operations under HSPA is not required when maximum average output of each RF channel with HSPA is less than 0.25 dB higher than as measured using 12.2 kbps RMC. Otherwise SAR is measured using same HSPA configuration as used for body SAR.

Sub-test	β_c	β_a	β_a (SF)	β_c/β_a	$\beta_{18}^{(1)}$	β_{ec}	β_{ed}	β_{ed} (SF)	β_{ed} (codes)	CM ⁽²⁾ (dB)	MPR (dB)	AG ⁽⁴⁾ Index	E-TFCI
1	11/15 ⁽³⁾	15/15 ⁽³⁾	64	11/15 ⁽³⁾	22/15	209/225	1039/225	4	1	1.0	0.0	20	75
2	6/15	15/15	64	6/15	12/15	12/15	94/75	4	1	3.0	2.0	12	67
3	15/15	9/15	64	15/9	30/15	30/15	$\beta_{a1}: 47/15$ $\beta_{a2}: 47/15$	4	2	2.0	1.0	15	92
4	2/15	15/15	64	2/15	4/15	2/15	56/75	4	1	3.0	2.0	17	71
5	15/15 ⁽⁴⁾	15/15 ⁽⁴⁾	64	15/15 ⁽⁴⁾	30/15	24/15	134/15	4	1	1.0	0.0	21	81

Note 1: Δ_{ACK} , Δ_{NACK} and $\Delta_{CQI} = 8 \Leftrightarrow A_{18} = \beta_{18}/\beta_c = 30/15 \Leftrightarrow \beta_{18} = 30/15 * \beta_c$.
 Note 2: CM = 1 for $\beta_c/\beta_a = 12/15$, $\beta_{18}/\beta_c = 24/15$. For all other combinations of DPDCH, DPCCCH, HS-DPCCCH, E-DPDCH and E-DPCCCH the MPR is based on the relative CM difference.
 Note 3: For subtest 1 the β_c/β_a ratio of 11/15 for the TFC during the measurement period (TF1, TF0) is achieved by setting the signaled gain factors for the reference TFC (TF1, TF1) to $\beta_c = 10/15$ and $\beta_a = 15/15$.
 Note 4: For subtest 5 the β_c/β_a ratio of 15/15 for the TFC during the measurement period (TF1, TF0) is achieved by setting the signaled gain factors for the reference TFC (TF1, TF1) to $\beta_c = 14/15$ and $\beta_a = 15/15$.
 Note 5: Testing UE using E-DPDCH Physical Layer category 1 Sub-test 3 is not required according to TS 25.306 Table 5.1g.
 Note 6: β_{ed} can not be set directly; it is set by Absolute Grant Value.

8.3.6 SAR Measurement Conditions for DC-HSDPA

SAR test exclusion for DC-HSDPA devices is determined by power measurements according to the H-Set 12, Fixed Reference Channel (FRC) configuration in Table C.8.1.12 of 3GPP TS 34.121-1. A primary and a secondary serving HS-DSCH Cell are required to perform the power measurement and for the results to qualify for SAR test exclusion. DC-HSDPA uplink maximum output power measurements using the four Rel. 5 HSDPA subtests in Table C.10.1.4 of TS 234.121-1 is required.

When the maximum average output power of each RF channel with DC-HSDPA active is $\leq \frac{1}{4}$ dB higher than that measured using 12.2 kbps RMC, or the maximum reported SAR for 12.2 kbps RMC is $\leq 75\%$ of the SAR limit, SAR evaluation for DC-HSDPA is not required.

8.4 SAR Measurement Conditions for LTE

LTE modes were tested according to FCC KDB 941225 D05v02 publication. Please see notes after the tabulated SAR data for required test configurations. Establishing connections with base station simulators ensure a consistent means for testing SAR and are recommended for evaluating SAR [4]. The R&S CMW500 was used for LTE output power measurements and SAR testing. Closed loop power control was used so the UE transmits with maximum output power during SAR testing. SAR tests were performed with the same number of RB and RB offsets transmitting on all TTI frames (maximum TTI).

8.4.1 Spectrum Plots for RB Configurations



A properly configured base station simulator was used for SAR tests and power measurements. Therefore, spectrum plots for RB configurations were not required to be included in this report.

8.4.2 MPR

MPR is permanently implemented for this device by the manufacturer. The specific manufacturer target MPR is indicated alongside the SAR results. MPR is enabled for this device, according to 3GPP TS36.101 Section 6.2.3 – 6.2.5 under Table 6.2.3-1.

8.4.3 A-MPR

A-MPR (Additional MPR) has been disabled for all SAR tests by setting NS=01 on the base station simulator.

FCC ID: A3LSMN915G		SAR EVALUATION REPORT		Reviewed by: Quality Manager
Document S/N: OY1408121709.A3L	Test Dates: 08/14/14 - 08/18/14	DUT Type: Portable Handset	Page 21 of 73	

8.4.4 Required RB Size and RB Offsets for SAR Testing

According to FCC KDB 941225 D05v02r01:

- a. Per Section 5.2.1, SAR is required for QPSK 1 RB Allocation for the largest bandwidth
 - i. The required channel and offset combination with the highest maximum output power is required for SAR.
 - ii. When the reported SAR is ≤ 0.8 W/kg, testing of the remaining RB offset configurations and required test channels is not required. Otherwise, SAR is required for the remaining required test channels using the RB offset configuration with highest output power for that channel.
 - iii. When the reported SAR for a required test channel is > 1.45 W/kg, SAR is required for all RB offset configurations for that channel.
- b. Per Section 5.2.2, SAR is required for 50% RB allocation using the largest bandwidth following the same procedures outlined in Section 5.2.1.
- c. Per Section 5.2.3, QPSK SAR is not required for the 100% allocation when the highest maximum output power for the 100% allocation is less than the highest maximum output power of the 1 RB and 50% RB allocations and the reported SAR for the 1 RB and 50% RB allocations is < 0.8 W/kg.
- d. Per Section 5.2.4 and 5.3, SAR tests for higher order modulations and lower bandwidths configurations are not required when the conducted power of the required test configurations determined by Sections 5.2.1 through 5.2.3 is less than or equal to $\frac{1}{2}$ dB higher than the equivalent configuration using QPSK modulation and when the QPSK SAR for those configurations is < 1.45 W/kg.

8.5 SAR Testing with 802.11 Transmitters

Normal network operating configurations are not suitable for measuring the SAR of 802.11 a/b/g/n/ac transmitters. Unpredictable fluctuations in network traffic and antenna diversity conditions can introduce undesirable variations in SAR results. The SAR for these devices should be measured using chipset based test mode software to ensure the results are consistent and reliable. See KDB Publication 248227 D01v01r02 for more details.



8.5.1 General Device Setup

Chipset based test mode software is hardware dependent and generally varies among manufacturers. The device operating parameters established in test mode for SAR measurements must be identical to those programmed in production units, including output power levels, amplifier gain settings and other RF performance tuning parameters. The test frequencies should correspond to actual channel frequencies defined for domestic use. SAR for devices with switched diversity should be measured with only one antenna transmitting at a time during each SAR measurement, according to a fixed modulation and data rate. The same data pattern should be used for all measurements.

8.5.2 Frequency Channel Configurations [24]

For 2.4 GHz, the highest average RF output power channel between the low, mid and high channel at the lowest data rate was selected for SAR evaluation in 802.11b mode. 802.11g/n modes and higher data rates for 802.11b were additionally evaluated for SAR if the output power of the respective mode was 0.25 dB or higher than the powers of the SAR configurations tested in the 802.11b mode.

For 5 GHz, the highest average RF output power channel across the default test channels at the lowest data rate was selected for SAR evaluation in 802.11a. When the adjacent channels are higher in power than the default channels, these "required channels" were considered instead of the default channels for SAR testing. 802.11n modes and higher data rates for 802.11a/n were evaluated only if the respective mode was higher than 0.25 dB or more than the 802.11a mode. 802.11ac SAR was



FCC ID: A3LSMN915G	 PCTEST ENGINEERING LABORATORY, INC.	SAR EVALUATION REPORT		Reviewed by: Quality Manager
Document S/N: OY1408121709.A3L	Test Dates: 08/14/14 - 08/18/14	DUT Type: Portable Handset		Page 22 of 73

evaluated for highest 802.11a configuration in each 5 GHz band and each exposure condition. 802.11ac modes were additionally evaluated for SAR if the output power for the respective mode was more than 0.25 dB higher than powers of 802.11a modes.

If the maximum extrapolated peak SAR of the zoom scan for the highest output channel was less than 1.6 W/kg and if the 1g averaged SAR was less than 0.8 W/kg, SAR testing was not required for the other test channels in the band.

8.5.3 MIMO SAR considerations

Per KDB 248227, SAR for MIMO was measured with both transmitting simultaneously and was evaluated independently of SISO operation. For 2.4 and 5 GHz MIMO, 802.11n 20 MHz BW was evaluated. Other IEEE 802.11 modes and bandwidths were not investigated for MIMO operations since the maximum allowed output power (including tolerance) was not higher for these modes.

FCC ID: A3LSMN915G	 SAR EVALUATION REPORT 		Reviewed by: Quality Manager
Document S/N: 0Y1408121709.A3L	Test Dates: 08/14/14 - 08/18/14	DUT Type: Portable Handset	Page 23 of 73

9 RF CONDUCTED POWERS



9.1 GSM Conducted Powers

		Maximum Burst-Averaged Output Power								
		Voice	GPRS/EDGE Data (GMSK)				EDGE Data (8-PSK)			
Band	Channel	GSM [dBm] CS (1 Slot)	GPRS [dBm] 1 Tx Slot	GPRS [dBm] 2 Tx Slot	GPRS [dBm] 3 Tx Slot	GPRS [dBm] 4 Tx Slot	EDGE [dBm] 1 Tx Slot	EDGE [dBm] 2 Tx Slot	EDGE [dBm] 3 Tx Slot	EDGE [dBm] 4 Tx Slot
GSM 850	128	32.84	32.66	29.81	28.08	27.29	24.30	22.98	21.84	20.94
	190	32.80	32.71	29.78	28.05	27.35	24.34	23.03	21.70	21.00
	251	32.83	32.76	29.87	28.17	27.10	24.51	22.92	21.79	21.10
GSM 1900	512	29.49	29.58	28.03	26.70	24.36	25.05	23.21	21.78	20.38
	661	29.54	29.53	28.24	26.54	24.88	25.03	23.12	21.72	20.41
	810	29.50	29.51	28.42	26.76	24.51	24.96	23.27	21.83	20.42

		Calculated Maximum Frame-Averaged Output Power								
		Voice	GPRS/EDGE Data (GMSK)				EDGE Data (8-PSK)			
Band	Channel	GSM [dBm] CS (1 Slot)	GPRS [dBm] 1 Tx Slot	GPRS [dBm] 2 Tx Slot	GPRS [dBm] 3 Tx Slot	GPRS [dBm] 4 Tx Slot	EDGE [dBm] 1 Tx Slot	EDGE [dBm] 2 Tx Slot	EDGE [dBm] 3 Tx Slot	EDGE [dBm] 4 Tx Slot
GSM 850	128	23.81	23.63	23.79	23.82	24.28	15.27	16.96	17.58	17.93
	190	23.77	23.68	23.76	23.79	24.34	15.31	17.01	17.44	17.99
	251	23.80	23.73	23.85	23.91	24.09	15.48	16.90	17.53	18.09
GSM 1900	512	20.46	20.55	22.01	22.44	21.35	16.02	17.19	17.52	17.37
	661	20.51	20.50	22.22	22.28	21.87	16.00	17.10	17.46	17.40
	810	20.47	20.48	22.40	22.50	21.50	15.93	17.25	17.57	17.41
GSM 850	Frame	23.97	23.97	24.48	24.24	24.99	16.47	17.98	18.24	18.99
GSM 1900	Avg.Targets:	20.47	20.47	22.48	22.24	21.99	16.47	17.48	18.24	18.49

Note:

- Both burst-averaged and calculated frame-averaged powers are included. Frame-averaged power was calculated from the measured burst-averaged power by converting the slot powers into linear units and calculating the energy over 8 timeslots.
- The source-based frame-averaged output power was evaluated for all GPRS/EDGE slot configurations. The configuration with the highest target frame averaged output power was evaluated for hotspot SAR. When the maximum frame-averaged powers are equivalent across two or more slots (within 0.25 dB), the configuration with the most number of time slots was tested.
- GPRS/EDGE (GMSK) output powers were measured with coding scheme setting of 1 (CS1) on the base station simulator. CS1 was configured to measure GPRS output power measurements and SAR to ensure GMSK modulation in the signal. Our Investigation has shown that CS1 - CS4 settings do not have any impact on the output levels or modulation in the GPRS modes.
- EDGE (8-PSK) output powers were measured with MCS7 on the base station simulator. MCS7 coding scheme was used to measure the output powers for EDGE since investigation has shown

FCC ID: A3LSMN915G	 PCTEST Engineering Laboratory, Inc.	SAR EVALUATION REPORT		Reviewed by: Quality Manager
Document S/N: OY1408121709.A3L	Test Dates: 08/14/14 - 08/18/14	DUT Type: Portable Handset		Page 24 of 73

that choosing MCS7 coding scheme will ensure 8-PSK modulation. It has been shown that MCS levels that produce 8PSK modulation do not have an impact on output power.

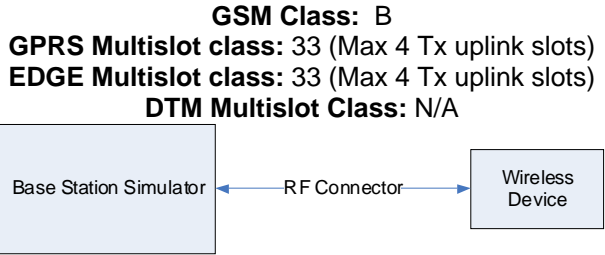

Figure 9-1
Power Measurement Setup

9.2 UMTS Conducted Powers

3GPP Release Version	Mode	3GPP 34.121 Subtest	Cellular Band [dBm]			PCS Band [dBm]			3GPP MPR [dB]
			4132	4183	4233	9262	9400	9538	
99	WCDMA	12.2 kbps RMC	23.39	23.40	22.91	22.47	22.70	21.82	-
99		12.2 kbps AMR	23.32	23.46	22.95	22.38	22.67	21.79	-
6	HSDPA	Subtest 1	23.06	22.88	22.22	22.03	22.23	21.54	0
6		Subtest 2	23.09	22.94	22.28	21.92	22.15	21.61	0
6		Subtest 3	22.62	22.47	21.83	21.57	21.81	21.17	0.5
6		Subtest 4	22.60	21.53	21.87	21.53	21.82	21.29	0.5
6	HSUPA	Subtest 1	22.33	22.26	21.82	21.52	21.85	21.44	0
6		Subtest 2	21.07	21.09	20.82	20.72	20.66	20.60	2
6		Subtest 3	22.42	22.21	21.96	21.46	21.36	21.18	1
6		Subtest 4	21.95	21.61	21.59	21.10	21.42	20.99	2
6		Subtest 5	22.99	22.82	22.20	22.00	22.20	21.64	0
8	DC-HSDPA	Subtest 1	23.11	23.15	22.55	22.29	22.88	21.68	0
8		Subtest 2	23.06	23.11	22.51	22.30	22.90	21.80	0
8		Subtest 3	22.69	22.61	22.14	21.66	22.41	21.27	0.5
8		Subtest 4	22.86	22.67	22.16	21.63	22.42	21.39	0.5

UMTS SAR was tested under RMC 12.2 kbps with HSPA Inactive per KDB Publication 941225 D01v02. HSPA SAR was not required since the average output power of the HSPA subtests was not more than 0.25 dB higher than the RMC level and SAR was less than 1.2 W/kg.

DC-HSDPA considerations

- 3GPP Specification 34.121-1 Release 8 Ver 8.10.0 was used for DC-HSDPA guidance
- H-Set 12 (QPSK) was confirmed to be used during DC-HSDPA measurements
- Measured maximum output powers for DC-HSDPA were not greater than 1/4 dB higher than the WCDMA 12.2 kbps RMC maximum output, as a result, SAR is not required for DC-HSDPA
- The DUT supports UE category 24 for HSDPA

It is expected by the manufacturer that MPR for some HSPA subtests may be up to 2 dB more than specified by 3GPP, but also as low as 0 dB according to the chipset implementation in this model.

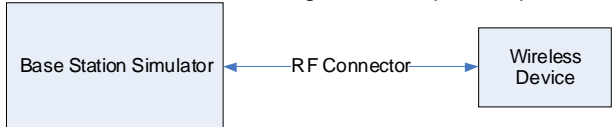



Figure 9-2
Power Measurement Setup

FCC ID: A3LSMN915G		SAR EVALUATION REPORT		Reviewed by: Quality Manager
Document S/N: OY1408121709.A3L	Test Dates: 08/14/14 - 08/18/14	DUT Type: Portable Handset	Page 25 of 73	

9.3 LTE Conducted Powers

9.3.1

LTE Band 5 (Cell)

Table 9-1
LTE Band 5 (Cell) Conducted Powers - 10 MHz Bandwidth

	Frequency [MHz]	Channel	Bandwidth [MHz]	Modulation	RB Size	RB Offset	Conducted Power [dBm]	MPR Allowed per 3GPP [dB]	MPR [dB]
Mid	836.5	20525	10	QPSK	1	0	22.70	0	0
	836.5	20525	10	QPSK	1	25	22.50	0	0
	836.5	20525	10	QPSK	1	49	22.57	0	0
	836.5	20525	10	QPSK	25	0	21.69	0-1	1
	836.5	20525	10	QPSK	25	12	21.53	0-1	1
	836.5	20525	10	QPSK	25	25	21.55	0-1	1
	836.5	20525	10	QPSK	50	0	21.60	0-1	1
	836.5	20525	10	16QAM	1	0	22.12	0-1	1
	836.5	20525	10	16QAM	1	25	21.80	0-1	1
	836.5	20525	10	16QAM	1	49	22.00	0-1	1
	836.5	20525	10	16QAM	25	0	20.77	0-2	2
	836.5	20525	10	16QAM	25	12	20.63	0-2	2
	836.5	20525	10	16QAM	25	25	20.60	0-2	2
	836.5	20525	10	16QAM	50	0	20.63	0-2	2

Note: LTE Band 5 (Cell) at 10 MHz bandwidth does not support three non-overlapping channels. Per KDB Publication 941225 D05v02, when a device supports overlapping channel assignment in a channel bandwidth configuration, the middle channel of the group of overlapping channels should be selected for testing.

Table 9-2
LTE Band 5 (Cell) Conducted Powers - 5 MHz Bandwidth

	Frequency [MHz]	Channel	Bandwidth [MHz]	Modulation	RB Size	RB Offset	Conducted Power [dBm]	MPR Allowed per 3GPP [dB]	MPR [dB]	
Low	826.5	20425	5	QPSK	1	0	22.58	0	0	
	826.5	20425	5	QPSK	1	12	22.55	0	0	
	826.5	20425	5	QPSK	1	24	22.57	0	0	
	826.5	20425	5	QPSK	12	0	21.58	0-1	1	
	826.5	20425	5	QPSK	12	6	21.50	0-1	1	
	826.5	20425	5	QPSK	12	13	21.52	0-1	1	
	826.5	20425	5	QPSK	25	0	21.52	0-1	1	
	826.5	20425	5	16-QAM	1	0	21.80	0-1	1	
	826.5	20425	5	16-QAM	1	12	21.65	0-1	1	
	826.5	20425	5	16-QAM	1	24	21.62	0-1	1	
	826.5	20425	5	16-QAM	12	0	20.58	0-2	2	
	826.5	20425	5	16-QAM	12	6	20.54	0-2	2	
	826.5	20425	5	16-QAM	12	13	20.55	0-2	2	
	826.5	20425	5	16-QAM	25	0	20.56	0-2	2	
	Mid	836.5	20525	5	QPSK	1	0	22.54	0	0
		836.5	20525	5	QPSK	1	12	22.51	0	0
		836.5	20525	5	QPSK	1	24	22.52	0	0
		836.5	20525	5	QPSK	12	0	21.54	0-1	1
		836.5	20525	5	QPSK	12	6	21.53	0-1	1
		836.5	20525	5	QPSK	12	13	21.57	0-1	1
836.5		20525	5	QPSK	25	0	21.50	0-1	1	
836.5		20525	5	16-QAM	1	0	21.66	0-1	1	
836.5		20525	5	16-QAM	1	12	21.59	0-1	1	
836.5		20525	5	16-QAM	1	24	21.56	0-1	1	
836.5		20525	5	16-QAM	12	0	20.53	0-2	2	
836.5		20525	5	16-QAM	12	6	20.52	0-2	2	
836.5		20525	5	16-QAM	12	13	20.52	0-2	2	
836.5		20525	5	16-QAM	25	0	20.53	0-2	2	
High		846.5	20625	5	QPSK	1	0	22.56	0	0
		846.5	20625	5	QPSK	1	12	22.51	0	0
		846.5	20625	5	QPSK	1	24	22.53	0	0
		846.5	20625	5	QPSK	12	0	21.53	0-1	1
		846.5	20625	5	QPSK	12	6	21.51	0-1	1
		846.5	20625	5	QPSK	12	13	21.62	0-1	1
	846.5	20625	5	QPSK	25	0	21.51	0-1	1	
	846.5	20625	5	16-QAM	1	0	21.80	0-1	1	
	846.5	20625	5	16-QAM	1	12	21.70	0-1	1	
	846.5	20625	5	16-QAM	1	24	21.74	0-1	1	
	846.5	20625	5	16-QAM	12	0	20.56	0-2	2	
	846.5	20625	5	16-QAM	12	6	20.50	0-2	2	
	846.5	20625	5	16-QAM	12	13	20.53	0-2	2	
	846.5	20625	5	16-QAM	25	0	20.53	0-2	2	





FCC ID: A3LSMN915G	 PCTEST Engineering Laboratory, Inc.	SAR EVALUATION REPORT		Reviewed by: Quality Manager
Document S/N: OY1408121709.A3L	Test Dates: 08/14/14 - 08/18/14	DUT Type: Portable Handset		Page 26 of 73

Table 9-3
LTE Band 5 (Cell) Conducted Powers - 3 MHz Bandwidth

	Frequency [MHz]	Channel	Bandwidth [MHz]	Modulation	RB Size	RB Offset	Conducted Power [dBm]	MPR Allowed per 3GPP [dB]	MPR [dB]	
Low	825.5	20415	3	QPSK	1	0	22.50	0	0	
	825.5	20415	3	QPSK	1	7	22.59	0	0	
	825.5	20415	3	QPSK	1	14	22.54	0	0	
	825.5	20415	3	QPSK	8	0	21.62	0-1	1	
	825.5	20415	3	QPSK	8	4	21.60	0-1	1	
	825.5	20415	3	QPSK	8	7	21.50	0-1	1	
	825.5	20415	3	QPSK	15	0	21.55	0-1	1	
	825.5	20415	3	16-QAM	1	0	21.54	0-1	1	
	825.5	20415	3	16-QAM	1	7	21.63	0-1	1	
	825.5	20415	3	16-QAM	1	14	21.70	0-1	1	
	825.5	20415	3	16-QAM	8	0	20.65	0-2	2	
	825.5	20415	3	16-QAM	8	4	20.66	0-2	2	
	825.5	20415	3	16-QAM	8	7	20.60	0-2	2	
	825.5	20415	3	16-QAM	15	0	20.59	0-2	2	
	Mid	836.5	20525	3	QPSK	1	0	22.51	0	0
		836.5	20525	3	QPSK	1	7	22.56	0	0
		836.5	20525	3	QPSK	1	14	22.54	0	0
		836.5	20525	3	QPSK	8	0	21.58	0-1	1
		836.5	20525	3	QPSK	8	4	21.60	0-1	1
		836.5	20525	3	QPSK	8	7	21.55	0-1	1
836.5		20525	3	QPSK	15	0	21.50	0-1	1	
836.5		20525	3	16-QAM	1	0	21.71	0-1	1	
836.5		20525	3	16-QAM	1	7	21.68	0-1	1	
836.5		20525	3	16-QAM	1	14	21.72	0-1	1	
836.5		20525	3	16-QAM	8	0	20.60	0-2	2	
836.5		20525	3	16-QAM	8	4	20.59	0-2	2	
836.5		20525	3	16-QAM	8	7	20.50	0-2	2	
836.5		20525	3	16-QAM	15	0	20.58	0-2	2	
High		847.5	20635	3	QPSK	1	0	22.53	0	0
		847.5	20635	3	QPSK	1	7	22.58	0	0
		847.5	20635	3	QPSK	1	14	22.59	0	0
		847.5	20635	3	QPSK	8	0	21.51	0-1	1
		847.5	20635	3	QPSK	8	4	21.57	0-1	1
		847.5	20635	3	QPSK	8	7	21.60	0-1	1
	847.5	20635	3	QPSK	15	0	21.61	0-1	1	
	847.5	20635	3	16-QAM	1	0	21.68	0-1	1	
	847.5	20635	3	16-QAM	1	7	21.70	0-1	1	
	847.5	20635	3	16-QAM	1	14	21.67	0-1	1	
	847.5	20635	3	16-QAM	8	0	20.68	0-2	2	
	847.5	20635	3	16-QAM	8	4	20.67	0-2	2	
	847.5	20635	3	16-QAM	8	7	20.70	0-2	2	
	847.5	20635	3	16-QAM	15	0	20.66	0-2	2	

Table 9-4
LTE Band 5 (Cell) Conducted Powers - 1.4 MHz Bandwidth

	Frequency [MHz]	Channel	Bandwidth [MHz]	Modulation	RB Size	RB Offset	Conducted Power [dBm]	MPR Allowed per 3GPP [dB]	MPR [dB]	
Low	824.7	20407	1.4	QPSK	1	0	22.54	0	0	
	824.7	20407	1.4	QPSK	1	2	22.52	0	0	
	824.7	20407	1.4	QPSK	1	5	22.61	0	0	
	824.7	20407	1.4	QPSK	3	0	22.57	0	0	
	824.7	20407	1.4	QPSK	3	2	22.59	0	0	
	824.7	20407	1.4	QPSK	3	3	22.50	0	0	
	824.7	20407	1.4	QPSK	6	0	21.70	0-1	1	
	824.7	20407	1.4	16-QAM	1	0	21.76	0-1	1	
	824.7	20407	1.4	16-QAM	1	2	21.77	0-1	1	
	824.7	20407	1.4	16-QAM	1	5	21.70	0-1	1	
	824.7	20407	1.4	16-QAM	3	0	21.68	0-1	1	
	824.7	20407	1.4	16-QAM	3	2	21.53	0-1	1	
	824.7	20407	1.4	16-QAM	3	3	21.59	0-1	1	
	824.7	20407	1.4	16-QAM	6	0	20.74	0-2	2	
	Mid	836.5	20525	1.4	QPSK	1	0	22.65	0	0
		836.5	20525	1.4	QPSK	1	2	22.66	0	0
		836.5	20525	1.4	QPSK	1	5	22.54	0	0
		836.5	20525	1.4	QPSK	3	0	22.68	0	0
		836.5	20525	1.4	QPSK	3	2	22.70	0	0
		836.5	20525	1.4	QPSK	3	3	22.54	0	0
836.5		20525	1.4	QPSK	6	0	21.83	0-1	1	
836.5		20525	1.4	16-QAM	1	0	21.72	0-1	1	
836.5		20525	1.4	16-QAM	1	2	21.68	0-1	1	
836.5		20525	1.4	16-QAM	1	5	21.66	0-1	1	
836.5		20525	1.4	16-QAM	3	0	21.71	0-1	1	
836.5		20525	1.4	16-QAM	3	2	21.65	0-1	1	
836.5		20525	1.4	16-QAM	3	3	21.70	0-1	1	
836.5		20525	1.4	16-QAM	6	0	20.58	0-2	2	
High		848.3	20643	1.4	QPSK	1	0	22.64	0	0
		848.3	20643	1.4	QPSK	1	2	22.59	0	0
		848.3	20643	1.4	QPSK	1	5	22.57	0	0
		848.3	20643	1.4	QPSK	3	0	22.74	0	0
		848.3	20643	1.4	QPSK	3	2	22.62	0	0
		848.3	20643	1.4	QPSK	3	3	22.61	0	0
	848.3	20643	1.4	QPSK	6	0	21.59	0-1	1	
	848.3	20643	1.4	16-QAM	1	0	21.71	0-1	1	
	848.3	20643	1.4	16-QAM	1	2	21.73	0-1	1	
	848.3	20643	1.4	16-QAM	1	5	21.70	0-1	1	
	848.3	20643	1.4	16-QAM	3	0	21.80	0-1	1	
	848.3	20643	1.4	16-QAM	3	2	21.77	0-1	1	
	848.3	20643	1.4	16-QAM	3	3	21.69	0-1	1	
	848.3	20643	1.4	16-QAM	6	0	20.60	0-2	2	

FCC ID: A3LSMN915G	 PCTEST ENGINEERING LABORATORY, INC.	SAR EVALUATION REPORT		Reviewed by: Quality Manager
Document S/N: OY1408121709.A3L	Test Dates: 08/14/14 - 08/18/14	DUT Type: Portable Handset	Page 27 of 73	

9.3.2

LTE Band 4 (AWS)



Table 9-5
 LTE Band 4 (AWS) Conducted Powers - 20 MHz Bandwidth

	Frequency [MHz]	Channel	Bandwidth [MHz]	Modulation	RB Size	RB Offset	Conducted Power [dBm]	MPR Allowed per 3GPP [dB]	MPR [dB]
Mid	1732.5	20175	20	QPSK	1	0	22.80	0	0
	1732.5	20175	20	QPSK	1	50	22.84	0	0
	1732.5	20175	20	QPSK	1	99	23.00	0	0
	1732.5	20175	20	QPSK	50	0	22.00	0-1	1
	1732.5	20175	20	QPSK	50	25	21.94	0-1	1
	1732.5	20175	20	QPSK	50	50	21.99	0-1	1
	1732.5	20175	20	QPSK	100	0	21.99	0-1	1
	1732.5	20175	20	16QAM	1	0	21.93	0-1	1
	1732.5	20175	20	16QAM	1	50	22.00	0-1	1
	1732.5	20175	20	16QAM	1	99	22.00	0-1	1
	1732.5	20175	20	16QAM	50	0	20.99	0-2	2
	1732.5	20175	20	16QAM	50	25	21.00	0-2	2
	1732.5	20175	20	16QAM	50	50	20.97	0-2	2
	1732.5	20175	20	16QAM	100	0	20.96	0-2	2

Note: LTE Band 4 (AWS) at 20 MHz bandwidth does not support three non-overlapping channels. Per KDB Publication 941225 D05v02, when a device supports overlapping channel assignment in a channel bandwidth configuration, the middle channel of the group of overlapping channels should be selected for testing.

Table 9-6
 LTE Band 4 (AWS) Conducted Powers - 15 MHz Bandwidth

	Frequency [MHz]	Channel	Bandwidth [MHz]	Modulation	RB Size	RB Offset	Conducted Power [dBm]	MPR Allowed per 3GPP [dB]	MPR [dB]
Low	1717.5	20025	15	QPSK	1	0	23.00	0	0
	1717.5	20025	15	QPSK	1	36	23.00	0	0
	1717.5	20025	15	QPSK	1	74	22.63	0	0
	1717.5	20025	15	QPSK	36	0	22.00	0-1	1
	1717.5	20025	15	QPSK	36	18	21.99	0-1	1
	1717.5	20025	15	QPSK	36	37	21.96	0-1	1
	1717.5	20025	15	QPSK	75	0	21.64	0-1	1
	1717.5	20025	15	16QAM	1	0	22.00	0-1	1
	1717.5	20025	15	16QAM	1	36	21.99	0-1	1
	1717.5	20025	15	16QAM	1	74	21.90	0-1	1
	1717.5	20025	15	16QAM	36	0	21.00	0-2	2
	1717.5	20025	15	16QAM	36	18	20.94	0-2	2
	1717.5	20025	15	16QAM	36	37	20.88	0-2	2
	1717.5	20025	15	16QAM	75	0	20.97	0-2	2
	1732.5	20175	15	QPSK	1	0	22.97	0	0
	1732.5	20175	15	QPSK	1	36	23.00	0	0
1732.5	20175	15	QPSK	1	74	23.00	0	0	
1732.5	20175	15	QPSK	36	0	22.00	0-1	1	
1732.5	20175	15	QPSK	36	18	21.99	0-1	1	
1732.5	20175	15	QPSK	36	37	21.98	0-1	1	
1732.5	20175	15	QPSK	75	0	21.98	0-1	1	
1732.5	20175	15	16QAM	1	0	22.00	0-1	1	
1732.5	20175	15	16QAM	1	36	21.98	0-1	1	
1732.5	20175	15	16QAM	1	74	22.00	0-1	1	
1732.5	20175	15	16QAM	36	0	20.96	0-2	2	
1732.5	20175	15	16QAM	36	18	21.00	0-2	2	
1732.5	20175	15	16QAM	36	37	21.00	0-2	2	
1732.5	20175	15	16QAM	75	0	20.90	0-2	2	
High	1747.5	20325	15	QPSK	1	0	22.85	0	0
	1747.5	20325	15	QPSK	1	36	23.00	0	0
	1747.5	20325	15	QPSK	1	74	22.21	0	0
	1747.5	20325	15	QPSK	36	0	22.00	0-1	1
	1747.5	20325	15	QPSK	36	18	22.00	0-1	1
	1747.5	20325	15	QPSK	36	37	21.99	0-1	1
	1747.5	20325	15	QPSK	75	0	21.98	0-1	1
	1747.5	20325	15	16QAM	1	0	21.87	0-1	1
	1747.5	20325	15	16QAM	1	36	22.00	0-1	1
	1747.5	20325	15	16QAM	1	74	21.30	0-1	1
	1747.5	20325	15	16QAM	36	0	20.96	0-2	2
	1747.5	20325	15	16QAM	36	18	21.00	0-2	2
	1747.5	20325	15	16QAM	36	37	20.97	0-2	2
	1747.5	20325	15	16QAM	75	0	20.90	0-2	2

FCC ID: A3LSMN915G	 PCTEST Engineering Laboratory, Inc.	SAR EVALUATION REPORT		Reviewed by: Quality Manager
Document S/N: OY1408121709.A3L	Test Dates: 08/14/14 - 08/18/14	DUT Type: Portable Handset		Page 28 of 73

**Table 9-7
LTE Band 4 (AWS) Conducted Powers - 10 MHz Bandwidth**

	Frequency [MHz]	Channel	Bandwidth [MHz]	Modulation	RB Size	RB Offset	Conducted Power [dBm]	MPR Allowed per 3GPP [dB]	MPR [dB]	
Low	1715	2000	10	QPSK	1	0	22.91	0	0	
	1715	2000	10	QPSK	1	25	23.00	0	0	
	1715	2000	10	QPSK	1	49	23.00	0	0	
	1715	2000	10	QPSK	25	0	21.92	0-1	1	
	1715	2000	10	QPSK	25	12	21.85	0-1	1	
	1715	2000	10	QPSK	25	25	22.00	0-1	1	
	1715	2000	10	QPSK	50	0	21.97	0-1	1	
	1715	2000	10	16QAM	1	0	21.88	0-1	1	
	1715	2000	10	16QAM	1	25	22.00	0-1	1	
	1715	2000	10	16QAM	1	49	21.96	0-1	1	
	1715	2000	10	16QAM	25	0	20.97	0-2	2	
	1715	2000	10	16QAM	25	12	21.00	0-2	2	
	1715	2000	10	16QAM	25	25	20.94	0-2	2	
	1715	2000	10	16QAM	50	0	20.97	0-2	2	
	Mid	1732.5	20175	10	QPSK	1	0	22.50	0	0
		1732.5	20175	10	QPSK	1	25	22.92	0	0
		1732.5	20175	10	QPSK	1	49	22.61	0	0
		1732.5	20175	10	QPSK	25	0	21.85	0-1	1
1732.5		20175	10	QPSK	25	12	21.96	0-1	1	
1732.5		20175	10	QPSK	25	25	22.00	0-1	1	
1732.5		20175	10	QPSK	50	0	21.94	0-1	1	
1732.5		20175	10	16QAM	1	0	21.94	0-1	1	
1732.5		20175	10	16QAM	1	25	22.00	0-1	1	
1732.5		20175	10	16QAM	1	49	21.96	0-1	1	
1732.5		20175	10	16QAM	25	0	20.95	0-2	2	
1732.5		20175	10	16QAM	25	12	20.96	0-2	2	
1732.5		20175	10	16QAM	25	25	21.00	0-2	2	
1732.5		20175	10	16QAM	50	0	21.00	0-2	2	
High		1750	20350	10	QPSK	1	0	22.90	0	0
		1750	20350	10	QPSK	1	25	23.00	0	0
		1750	20350	10	QPSK	1	49	22.00	0	0
		1750	20350	10	QPSK	25	0	21.99	0-1	1
	1750	20350	10	QPSK	25	12	22.00	0-1	1	
	1750	20350	10	QPSK	25	25	22.00	0-1	1	
	1750	20350	10	QPSK	50	0	21.97	0-1	1	
	1750	20350	10	16QAM	1	0	21.93	0-1	1	
	1750	20350	10	16QAM	1	25	22.00	0-1	1	
	1750	20350	10	16QAM	1	49	21.00	0-1	1	
	1750	20350	10	16QAM	25	0	20.97	0-2	2	
	1750	20350	10	16QAM	25	12	20.99	0-2	2	
	1750	20350	10	16QAM	25	25	21.00	0-2	2	
	1750	20350	10	16QAM	50	0	20.97	0-2	2	

**Table 9-8
LTE Band 4 (AWS) Conducted Powers - 5 MHz Bandwidth**

	Frequency [MHz]	Channel	Bandwidth [MHz]	Modulation	RB Size	RB Offset	Conducted Power [dBm]	MPR Allowed per 3GPP [dB]	MPR [dB]	
Low	1712.5	19975	5	QPSK	1	0	22.87	0	0	
	1712.5	19975	5	QPSK	1	12	22.98	0	0	
	1712.5	19975	5	QPSK	1	24	23.00	0	0	
	1712.5	19975	5	QPSK	12	0	21.94	0-1	1	
	1712.5	19975	5	QPSK	12	6	22.00	0-1	1	
	1712.5	19975	5	QPSK	12	13	22.00	0-1	1	
	1712.5	19975	5	QPSK	25	0	21.99	0-1	1	
	1712.5	19975	5	16-QAM	1	0	21.96	0-1	1	
	1712.5	19975	5	16-QAM	1	12	22.00	0-1	1	
	1712.5	19975	5	16-QAM	1	24	22.00	0-1	1	
	1712.5	19975	5	16-QAM	12	0	21.00	0-2	2	
	1712.5	19975	5	16-QAM	12	6	20.95	0-2	2	
	1712.5	19975	5	16-QAM	12	13	21.00	0-2	2	
	1712.5	19975	5	16-QAM	25	0	20.96	0-2	2	
	Mid	1732.5	20175	5	QPSK	1	0	22.46	0	0
		1732.5	20175	5	QPSK	1	12	22.79	0	0
		1732.5	20175	5	QPSK	1	24	22.80	0	0
		1732.5	20175	5	QPSK	12	0	21.85	0-1	1
1732.5		20175	5	QPSK	12	6	22.00	0-1	1	
1732.5		20175	5	QPSK	12	13	21.98	0-1	1	
1732.5		20175	5	QPSK	25	0	21.89	0-1	1	
1732.5		20175	5	16-QAM	1	0	21.66	0-1	1	
1732.5		20175	5	16-QAM	1	12	22.00	0-1	1	
1732.5		20175	5	16-QAM	1	24	21.99	0-1	1	
1732.5		20175	5	16-QAM	12	0	20.91	0-2	2	
1732.5		20175	5	16-QAM	12	6	20.95	0-2	2	
1732.5		20175	5	16-QAM	12	13	21.00	0-2	2	
1732.5		20175	5	16-QAM	25	0	20.96	0-2	2	
High		1752.5	20375	5	QPSK	1	0	23.00	0	0
		1752.5	20375	5	QPSK	1	12	22.97	0	0
		1752.5	20375	5	QPSK	1	24	22.00	0	0
		1752.5	20375	5	QPSK	12	0	22.00	0-1	1
	1752.5	20375	5	QPSK	12	6	21.98	0-1	1	
	1752.5	20375	5	QPSK	12	13	21.96	0-1	1	
	1752.5	20375	5	QPSK	25	0	21.97	0-1	1	
	1752.5	20375	5	16-QAM	1	0	22.00	0-1	1	
	1752.5	20375	5	16-QAM	1	12	21.94	0-1	1	
	1752.5	20375	5	16-QAM	1	24	21.91	0-1	1	
	1752.5	20375	5	16-QAM	12	0	21.00	0-2	2	
	1752.5	20375	5	16-QAM	12	6	20.91	0-2	2	
	1752.5	20375	5	16-QAM	12	13	20.92	0-2	2	
	1752.5	20375	5	16-QAM	25	0	21.00	0-2	2	



FCC ID: A3LSMN915G		SAR EVALUATION REPORT		Reviewed by: Quality Manager
Document S/N: OY1408121709.A3L	Test Dates: 08/14/14 - 08/18/14	DUT Type: Portable Handset	Page 29 of 73	

Table 9-9
LTE Band 4 (AWS) Conducted Powers - 3 MHz Bandwidth

	Frequency [MHz]	Channel	Bandwidth [MHz]	Modulation	RB Size	RB Offset	Conducted Power [dBm]	MPR Allowed per 3GPP [dB]	MPR [dB]
Low	1711.5	19965	3	QPSK	1	0	22.97	0	0
	1711.5	19965	3	QPSK	1	7	23.00	0	0
	1711.5	19965	3	QPSK	1	14	22.98	0	0
	1711.5	19965	3	QPSK	8	0	21.98	0-1	1
	1711.5	19965	3	QPSK	8	4	22.00	0-1	1
	1711.5	19965	3	QPSK	8	7	21.95	0-1	1
	1711.5	19965	3	QPSK	15	0	22.00	0-1	1
	1711.5	19965	3	16-QAM	1	0	21.93	0-1	1
	1711.5	19965	3	16-QAM	1	7	22.00	0-1	1
	1711.5	19965	3	16-QAM	1	14	21.96	0-1	1
	1711.5	19965	3	16-QAM	8	0	20.97	0-2	2
	1711.5	19965	3	16-QAM	8	4	21.00	0-2	2
	1711.5	19965	3	16-QAM	8	7	20.97	0-2	2
	1711.5	19965	3	16-QAM	15	0	20.99	0-2	2
	1711.5	19965	3	16-QAM	15	0	20.99	0-2	2
Mid	1732.5	20175	3	QPSK	1	0	22.69	0	0
	1732.5	20175	3	QPSK	1	7	22.96	0	0
	1732.5	20175	3	QPSK	1	14	22.99	0	0
	1732.5	20175	3	QPSK	8	0	22.00	0-1	1
	1732.5	20175	3	QPSK	8	4	21.96	0-1	1
	1732.5	20175	3	QPSK	8	7	21.99	0-1	1
	1732.5	20175	3	QPSK	15	0	22.00	0-1	1
	1732.5	20175	3	16-QAM	1	0	21.90	0-1	1
	1732.5	20175	3	16-QAM	1	7	22.00	0-1	1
	1732.5	20175	3	16-QAM	1	14	21.98	0-1	1
	1732.5	20175	3	16-QAM	8	0	20.85	0-2	2
	1732.5	20175	3	16-QAM	8	4	20.87	0-2	2
	1732.5	20175	3	16-QAM	8	7	20.96	0-2	2
	1732.5	20175	3	16-QAM	15	0	20.96	0-2	2
	1732.5	20175	3	16-QAM	15	0	20.96	0-2	2
High	1753.5	20385	3	QPSK	1	0	23.00	0	0
	1753.5	20385	3	QPSK	1	7	22.56	0	0
	1753.5	20385	3	QPSK	1	14	22.62	0	0
	1753.5	20385	3	QPSK	8	0	21.97	0-1	1
	1753.5	20385	3	QPSK	8	4	22.00	0-1	1
	1753.5	20385	3	QPSK	8	7	21.00	0-1	1
	1753.5	20385	3	QPSK	15	0	21.98	0-1	1
	1753.5	20385	3	16-QAM	1	0	22.00	0-1	1
	1753.5	20385	3	16-QAM	1	7	21.83	0-1	1
	1753.5	20385	3	16-QAM	1	14	21.00	0-1	1
	1753.5	20385	3	16-QAM	8	0	20.95	0-2	2
	1753.5	20385	3	16-QAM	8	4	21.00	0-2	2
	1753.5	20385	3	16-QAM	8	7	20.04	0-2	2
	1753.5	20385	3	16-QAM	15	0	20.85	0-2	2
	1753.5	20385	3	16-QAM	15	0	20.85	0-2	2

Table 9-10
LTE Band 4 (AWS) Conducted Powers -1.4 MHz Bandwidth

	Frequency [MHz]	Channel	Bandwidth [MHz]	Modulation	RB Size	RB Offset	Conducted Power [dBm]	MPR Allowed per 3GPP [dB]	MPR [dB]
Low	1710.7	19957	1.4	QPSK	1	0	22.91	0	0
	1710.7	19957	1.4	QPSK	1	2	23.00	0	0
	1710.7	19957	1.4	QPSK	1	5	22.97	0	0
	1710.7	19957	1.4	QPSK	3	0	22.99	0	0
	1710.7	19957	1.4	QPSK	3	2	23.00	0	0
	1710.7	19957	1.4	QPSK	3	3	22.98	0	0
	1710.7	19957	1.4	QPSK	6	0	22.00	0-1	1
	1710.7	19957	1.4	16-QAM	1	0	21.89	0-1	1
	1710.7	19957	1.4	16-QAM	1	2	21.98	0-1	1
	1710.7	19957	1.4	16-QAM	1	5	21.99	0-1	1
	1710.7	19957	1.4	16-QAM	3	0	22.00	0-1	1
	1710.7	19957	1.4	16-QAM	3	2	21.92	0-1	1
	1710.7	19957	1.4	16-QAM	3	3	22.00	0-1	1
	1710.7	19957	1.4	16-QAM	6	0	20.93	0-2	2
	1710.7	19957	1.4	16-QAM	6	0	20.93	0-2	2
Mid	1732.5	20175	1.4	QPSK	1	0	22.80	0	0
	1732.5	20175	1.4	QPSK	1	2	22.94	0	0
	1732.5	20175	1.4	QPSK	1	5	22.86	0	0
	1732.5	20175	1.4	QPSK	3	0	22.81	0	0
	1732.5	20175	1.4	QPSK	3	2	22.93	0	0
	1732.5	20175	1.4	QPSK	3	3	22.85	0	0
	1732.5	20175	1.4	QPSK	6	0	21.00	0-1	1
	1732.5	20175	1.4	16-QAM	1	0	21.80	0-1	1
	1732.5	20175	1.4	16-QAM	1	2	21.95	0-1	1
	1732.5	20175	1.4	16-QAM	1	5	21.97	0-1	1
	1732.5	20175	1.4	16-QAM	3	0	21.94	0-1	1
	1732.5	20175	1.4	16-QAM	3	2	21.95	0-1	1
	1732.5	20175	1.4	16-QAM	3	3	21.97	0-1	1
	1732.5	20175	1.4	16-QAM	6	0	20.88	0-2	2
	1732.5	20175	1.4	16-QAM	6	0	20.88	0-2	2
High	1754.3	20393	1.4	QPSK	1	0	22.52	0	0
	1754.3	20393	1.4	QPSK	1	2	22.03	0	0
	1754.3	20393	1.4	QPSK	1	5	22.00	0	0
	1754.3	20393	1.4	QPSK	3	0	22.04	0	0
	1754.3	20393	1.4	QPSK	3	2	22.00	0	0
	1754.3	20393	1.4	QPSK	3	3	22.01	0	0
	1754.3	20393	1.4	QPSK	6	0	21.02	0-1	1
	1754.3	20393	1.4	16-QAM	1	0	21.76	0-1	1
	1754.3	20393	1.4	16-QAM	1	2	21.03	0-1	1
	1754.3	20393	1.4	16-QAM	1	5	21.00	0-1	1
	1754.3	20393	1.4	16-QAM	3	0	21.02	0-1	1
	1754.3	20393	1.4	16-QAM	3	2	21.21	0-1	1
	1754.3	20393	1.4	16-QAM	3	3	21.00	0-1	1
	1754.3	20393	1.4	16-QAM	6	0	20.10	0-2	2
	1754.3	20393	1.4	16-QAM	6	0	20.10	0-2	2

9.3.3

LTE Band 2 (PCS)

Table 9-11
LTE Band 2 (PCS) Conducted Powers - 20 MHz Bandwidth

	Frequency [MHz]	Channel	Bandwidth [MHz]	Modulation	RB Size	RB Offset	Conducted Power [dBm]	MPR Allowed per 3GPP [dB]	MPR [dB]	
Low	1860	18700	20	QPSK	1	0	22.88	0	0	
	1860	18700	20	QPSK	1	50	22.62	0	0	
	1860	18700	20	QPSK	1	99	22.49	0	0	
	1860	18700	20	QPSK	50	0	21.88	0-1	1	
	1860	18700	20	QPSK	50	25	21.64	0-1	1	
	1860	18700	20	QPSK	50	50	21.61	0-1	1	
	1860	18700	20	QPSK	100	0	21.75	0-1	1	
	1860	18700	20	16QAM	1	0	22.00	0-1	1	
	1860	18700	20	16QAM	1	50	21.80	0-1	1	
	1860	18700	20	16QAM	1	99	21.99	0-1	1	
	1860	18700	20	16QAM	50	0	20.88	0-2	2	
	1860	18700	20	16QAM	50	25	20.67	0-2	2	
	1860	18700	20	16QAM	50	50	20.63	0-2	2	
	1860	18700	20	16QAM	100	0	20.75	0-2	2	
	Mid	1880.0	18900	20	QPSK	1	0	22.66	0	0
		1880.0	18900	20	QPSK	1	50	22.74	0	0
		1880.0	18900	20	QPSK	1	99	22.74	0	0
		1880.0	18900	20	QPSK	50	0	21.87	0-1	1
1880.0		18900	20	QPSK	50	25	21.71	0-1	1	
1880.0		18900	20	QPSK	50	50	21.68	0-1	1	
1880.0		18900	20	QPSK	100	0	21.68	0-1	1	
1880.0		18900	20	16QAM	1	0	21.89	0-1	1	
1880.0		18900	20	16QAM	1	50	22.00	0-1	1	
1880.0		18900	20	16QAM	1	99	21.97	0-1	1	
1880.0		18900	20	16QAM	50	0	20.91	0-2	2	
1880.0		18900	20	16QAM	50	25	20.76	0-2	2	
1880.0		18900	20	16QAM	50	50	20.73	0-2	2	
1880.0		18900	20	16QAM	100	0	20.69	0-2	2	
High		1900	19100	20	QPSK	1	0	22.37	0	0
		1900	19100	20	QPSK	1	50	22.46	0	0
		1900	19100	20	QPSK	1	99	22.16	0	0
		1900	19100	20	QPSK	50	0	21.46	0-1	1
	1900	19100	20	QPSK	50	25	21.49	0-1	1	
	1900	19100	20	QPSK	50	50	21.46	0-1	1	
	1900	19100	20	QPSK	100	0	21.40	0-1	1	
	1900	19100	20	16QAM	1	0	21.61	0-1	1	
	1900	19100	20	16QAM	1	50	21.67	0-1	1	
	1900	19100	20	16QAM	1	99	21.28	0-1	1	
	1900	19100	20	16QAM	50	0	20.72	0-2	2	
	1900	19100	20	16QAM	50	25	20.49	0-2	2	
	1900	19100	20	16QAM	50	50	20.44	0-2	2	
	1900	19100	20	16QAM	100	0	20.45	0-2	2	

Table 9-12
LTE Band 2 (PCS) Conducted Powers - 15 MHz Bandwidth

	Frequency [MHz]	Channel	Bandwidth [MHz]	Modulation	RB Size	RB Offset	Conducted Power [dBm]	MPR Allowed per 3GPP [dB]	MPR [dB]	
Low	1857.5	18675	15	QPSK	1	0	22.48	0	0	
	1857.5	18675	15	QPSK	1	36	22.55	0	0	
	1857.5	18675	15	QPSK	1	74	22.59	0	0	
	1857.5	18675	15	QPSK	36	0	21.48	0-1	1	
	1857.5	18675	15	QPSK	36	18	21.50	0-1	1	
	1857.5	18675	15	QPSK	36	37	21.58	0-1	1	
	1857.5	18675	15	QPSK	75	0	21.56	0-1	1	
	1857.5	18675	15	16QAM	1	0	21.69	0-1	1	
	1857.5	18675	15	16QAM	1	36	21.50	0-1	1	
	1857.5	18675	15	16QAM	1	74	21.54	0-1	1	
	1857.5	18675	15	16QAM	36	0	20.38	0-2	2	
	1857.5	18675	15	16QAM	36	18	20.39	0-2	2	
	1857.5	18675	15	16QAM	36	37	20.46	0-2	2	
	1857.5	18675	15	16QAM	75	0	20.44	0-2	2	
	Mid	1880.0	18900	15	QPSK	1	0	22.60	0	0
		1880.0	18900	15	QPSK	1	36	22.63	0	0
		1880.0	18900	15	QPSK	1	74	22.50	0	0
		1880.0	18900	15	QPSK	36	0	21.46	0-1	1
1880.0		18900	15	QPSK	36	18	21.44	0-1	1	
1880.0		18900	15	QPSK	36	37	21.39	0-1	1	
1880.0		18900	15	QPSK	75	0	21.58	0-1	1	
1880.0		18900	15	16QAM	1	0	21.60	0-1	1	
1880.0		18900	15	16QAM	1	36	21.60	0-1	1	
1880.0		18900	15	16QAM	1	74	21.63	0-1	1	
1880.0		18900	15	16QAM	36	0	20.50	0-2	2	
1880.0		18900	15	16QAM	36	18	20.57	0-2	2	
1880.0		18900	15	16QAM	36	37	20.47	0-2	2	
1880.0		18900	15	16QAM	75	0	20.48	0-2	2	
High		1902.5	19125	15	QPSK	1	0	22.59	0	0
		1902.5	19125	15	QPSK	1	36	22.66	0	0
		1902.5	19125	15	QPSK	1	74	22.47	0	0
		1902.5	19125	15	QPSK	36	0	21.54	0-1	1
	1902.5	19125	15	QPSK	36	18	21.47	0-1	1	
	1902.5	19125	15	QPSK	36	37	21.66	0-1	1	
	1902.5	19125	15	QPSK	75	0	21.55	0-1	1	
	1902.5	19125	15	16QAM	1	0	21.73	0-1	1	
	1902.5	19125	15	16QAM	1	36	21.70	0-1	1	
	1902.5	19125	15	16QAM	1	74	21.59	0-1	1	
	1902.5	19125	15	16QAM	36	0	20.47	0-2	2	
	1902.5	19125	15	16QAM	36	18	20.44	0-2	2	
	1902.5	19125	15	16QAM	36	37	20.57	0-2	2	
	1902.5	19125	15	16QAM	75	0	20.53	0-2	2	



FCC ID: A3LSMN915G	 PCTEST Engineering Laboratory, Inc.	SAR EVALUATION REPORT		Reviewed by: Quality Manager
Document S/N: OY1408121709.A3L	Test Dates: 08/14/14 - 08/18/14	DUT Type: Portable Handset	Page 31 of 73	

Table 9-13

LTE Band 2 (PCS) Conducted Powers - 10 MHz Bandwidth

	Frequency [MHz]	Channel	Bandwidth [MHz]	Modulation	RB Size	RB Offset	Conducted Power [dBm]	MPR Allowed per 3GPP [dB]	MPR [dB]
Low	1855	18650	10	QPSK	1	0	22.33	0	0
	1855	18650	10	QPSK	1	25	22.58	0	0
	1855	18650	10	QPSK	1	49	22.51	0	0
	1855	18650	10	QPSK	25	0	21.61	-0.1	1
	1855	18650	10	QPSK	25	12	21.60	-0.1	1
	1855	18650	10	QPSK	25	25	21.58	-0.1	1
	1855	18650	10	QPSK	50	0	21.55	-0.1	1
	1855	18650	10	16QAM	1	0	21.70	-0.1	1
	1855	18650	10	16QAM	1	25	21.62	-0.1	1
	1855	18650	10	16QAM	1	49	21.66	-0.1	1
	1855	18650	10	16QAM	25	0	20.48	-0.2	2
	1855	18650	10	16QAM	25	12	20.49	-0.2	2
	1855	18650	10	16QAM	25	25	20.37	-0.2	2
	1855	18650	10	16QAM	50	0	20.50	-0.2	2
	1880.0	18900	10	QPSK	1	0	22.45	0	0
1880.0	18900	10	QPSK	1	25	22.55	0	0	
1880.0	18900	10	QPSK	1	49	22.42	0	0	
1880.0	18900	10	QPSK	25	0	21.42	-0.1	1	
1880.0	18900	10	QPSK	25	12	21.36	-0.1	1	
1880.0	18900	10	QPSK	25	25	21.48	-0.1	1	
1880.0	18900	10	QPSK	50	0	21.60	-0.1	1	
1880.0	18900	10	16QAM	1	0	21.30	-0.1	1	
1880.0	18900	10	16QAM	1	25	21.41	-0.1	1	
1880.0	18900	10	16QAM	1	49	21.11	-0.1	1	
1880.0	18900	10	16QAM	25	0	20.60	-0.2	2	
1880.0	18900	10	16QAM	25	12	20.58	-0.2	2	
1880.0	18900	10	16QAM	25	25	20.53	-0.2	2	
1880.0	18900	10	16QAM	50	0	20.44	-0.2	2	
Mid	1880.0	18900	10	QPSK	1	0	22.45	0	0
	1880.0	18900	10	QPSK	1	25	22.55	0	0
	1880.0	18900	10	QPSK	1	49	22.42	0	0
	1880.0	18900	10	QPSK	25	0	21.42	-0.1	1
	1880.0	18900	10	QPSK	25	12	21.36	-0.1	1
	1880.0	18900	10	QPSK	25	25	21.48	-0.1	1
	1880.0	18900	10	QPSK	50	0	21.60	-0.1	1
	1880.0	18900	10	16QAM	1	0	21.30	-0.1	1
	1880.0	18900	10	16QAM	1	25	21.41	-0.1	1
	1880.0	18900	10	16QAM	1	49	21.11	-0.1	1
	1880.0	18900	10	16QAM	25	0	20.60	-0.2	2
	1880.0	18900	10	16QAM	25	12	20.58	-0.2	2
	1880.0	18900	10	16QAM	25	25	20.53	-0.2	2
	1880.0	18900	10	16QAM	50	0	20.44	-0.2	2
	1905	19150	10	QPSK	1	0	22.63	0	0
1905	19150	10	QPSK	1	25	22.58	0	0	
1905	19150	10	QPSK	1	49	22.42	0	0	
1905	19150	10	QPSK	25	0	21.35	-0.1	1	
1905	19150	10	QPSK	25	12	21.55	-0.1	1	
1905	19150	10	QPSK	25	25	21.61	-0.1	1	
1905	19150	10	QPSK	50	0	21.51	-0.1	1	
1905	19150	10	16QAM	1	0	21.45	-0.1	1	
1905	19150	10	16QAM	1	25	21.67	-0.1	1	
1905	19150	10	16QAM	1	49	21.43	-0.1	1	
1905	19150	10	16QAM	25	0	20.61	-0.2	2	
1905	19150	10	16QAM	25	12	20.47	-0.2	2	
1905	19150	10	16QAM	25	25	20.53	-0.2	2	
1905	19150	10	16QAM	50	0	20.55	-0.2	2	
High	1905	19150	10	QPSK	1	0	22.63	0	0
	1905	19150	10	QPSK	1	25	22.58	0	0
	1905	19150	10	QPSK	1	49	22.42	0	0
	1905	19150	10	QPSK	25	0	21.35	-0.1	1
	1905	19150	10	QPSK	25	12	21.55	-0.1	1
	1905	19150	10	QPSK	25	25	21.61	-0.1	1
	1905	19150	10	QPSK	50	0	21.51	-0.1	1
	1905	19150	10	16QAM	1	0	21.45	-0.1	1
	1905	19150	10	16QAM	1	25	21.67	-0.1	1
	1905	19150	10	16QAM	1	49	21.43	-0.1	1
	1905	19150	10	16QAM	25	0	20.61	-0.2	2
	1905	19150	10	16QAM	25	12	20.47	-0.2	2
	1905	19150	10	16QAM	25	25	20.53	-0.2	2
	1905	19150	10	16QAM	50	0	20.55	-0.2	2

Table 9-14

LTE Band 2 (PCS) Conducted Powers - 5 MHz Bandwidth

	Frequency [MHz]	Channel	Bandwidth [MHz]	Modulation	RB Size	RB Offset	Conducted Power [dBm]	MPR Allowed per 3GPP [dB]	MPR [dB]
Low	1852.5	18625	5	QPSK	1	0	22.52	0	0
	1852.5	18625	5	QPSK	1	12	22.60	0	0
	1852.5	18625	5	QPSK	1	24	22.30	0	0
	1852.5	18625	5	QPSK	12	0	21.24	-0.1	1
	1852.5	18625	5	QPSK	12	6	21.52	-0.1	1
	1852.5	18625	5	QPSK	12	13	21.58	-0.1	1
	1852.5	18625	5	QPSK	25	0	21.73	-0.1	1
	1852.5	18625	5	16-QAM	1	0	21.71	-0.1	1
	1852.5	18625	5	16-QAM	1	12	21.77	-0.1	1
	1852.5	18625	5	16-QAM	1	24	21.50	-0.1	1
	1852.5	18625	5	16-QAM	12	0	20.40	-0.2	2
	1852.5	18625	5	16-QAM	12	6	20.32	-0.2	2
	1852.5	18625	5	16-QAM	12	13	20.48	-0.2	2
	1852.5	18625	5	16-QAM	25	0	20.38	-0.2	2
	1880.0	18900	5	QPSK	1	0	22.69	0	0
1880.0	18900	5	QPSK	1	12	22.54	0	0	
1880.0	18900	5	QPSK	1	24	22.58	0	0	
1880.0	18900	5	QPSK	12	0	21.21	-0.1	1	
1880.0	18900	5	QPSK	12	6	21.57	-0.1	1	
1880.0	18900	5	QPSK	12	13	21.59	-0.1	1	
1880.0	18900	5	QPSK	25	0	21.60	-0.1	1	
1880.0	18900	5	16-QAM	1	0	21.83	-0.1	1	
1880.0	18900	5	16-QAM	1	12	21.79	-0.1	1	
1880.0	18900	5	16-QAM	1	24	21.77	-0.1	1	
1880.0	18900	5	16-QAM	12	0	20.22	-0.2	2	
1880.0	18900	5	16-QAM	12	6	20.25	-0.2	2	
1880.0	18900	5	16-QAM	12	13	20.58	-0.2	2	
1880.0	18900	5	16-QAM	25	0	20.54	-0.2	2	
1907.5	19175	5	QPSK	1	0	22.64	0	0	
1907.5	19175	5	QPSK	1	12	22.43	0	0	
1907.5	19175	5	QPSK	1	24	22.59	0	0	
1907.5	19175	5	QPSK	12	0	21.31	-0.1	1	
1907.5	19175	5	QPSK	12	6	21.44	-0.1	1	
1907.5	19175	5	QPSK	12	13	21.32	-0.1	1	
1907.5	19175	5	QPSK	25	0	21.47	-0.1	1	
1907.5	19175	5	16-QAM	1	0	21.85	-0.1	1	
1907.5	19175	5	16-QAM	1	12	21.93	-0.1	1	
1907.5	19175	5	16-QAM	1	24	21.54	-0.1	1	
1907.5	19175	5	16-QAM	12	0	20.33	-0.2	2	
1907.5	19175	5	16-QAM	12	6	20.25	-0.2	2	
1907.5	19175	5	16-QAM	12	13	20.52	-0.2	2	
1907.5	19175	5	16-QAM	25	0	20.44	-0.2	2	

Table 9-15

LTE Band 2 (PCS) Conducted Powers - 3 MHz Bandwidth

	Frequency [MHz]	Channel	Bandwidth [MHz]	Modulation	RB Size	RB Offset	Conducted Power [dBm]	MPR Allowed per 3GPP [dB]	MPR [dB]	
Low	1851.5	18615	3	QPSK	1	0	22.56	0	0	
	1851.5	18615	3	QPSK	1	7	22.44	0	0	
	1851.5	18615	3	QPSK	1	14	22.38	0	0	
	1851.5	18615	3	QPSK	8	0	21.44	0-1	1	
	1851.5	18615	3	QPSK	8	4	21.45	0-1	1	
	1851.5	18615	3	QPSK	8	7	21.27	0-1	1	
	1851.5	18615	3	QPSK	15	0	21.44	0-1	1	
	1851.5	18615	3	16-QAM	1	0	21.61	0-1	1	
	1851.5	18615	3	16-QAM	1	7	21.64	0-1	1	
	1851.5	18615	3	16-QAM	1	14	21.51	0-1	1	
	1851.5	18615	3	16-QAM	8	0	20.21	0-2	2	
	1851.5	18615	3	16-QAM	8	4	20.58	0-2	2	
	1851.5	18615	3	16-QAM	8	7	20.48	0-2	2	
	1851.5	18615	3	16-QAM	15	0	20.57	0-2	2	
	Mid	1880.0	18900	3	QPSK	1	0	22.60	0	0
		1880.0	18900	3	QPSK	1	7	22.67	0	0
		1880.0	18900	3	QPSK	1	14	22.47	0	0
		1880.0	18900	3	QPSK	8	0	21.78	0-1	1
1880.0		18900	3	QPSK	8	4	21.41	0-1	1	
1880.0		18900	3	QPSK	8	7	21.53	0-1	1	
1880.0		18900	3	QPSK	15	0	21.52	0-1	1	
1880.0		18900	3	16-QAM	1	0	21.72	0-1	1	
1880.0		18900	3	16-QAM	1	7	21.79	0-1	1	
1880.0		18900	3	16-QAM	1	14	21.54	0-1	1	
1880.0		18900	3	16-QAM	8	0	20.41	0-2	2	
1880.0		18900	3	16-QAM	8	4	20.61	0-2	2	
1880.0		18900	3	16-QAM	8	7	20.74	0-2	2	
1880.0		18900	3	16-QAM	15	0	20.58	0-2	2	
High		1908.5	19185	3	QPSK	1	0	22.78	0	0
		1908.5	19185	3	QPSK	1	7	22.45	0	0
		1908.5	19185	3	QPSK	1	14	22.58	0	0
		1908.5	19185	3	QPSK	8	0	21.65	0-1	1
	1908.5	19185	3	QPSK	8	4	21.32	0-1	1	
	1908.5	19185	3	QPSK	8	7	21.61	0-1	1	
	1908.5	19185	3	QPSK	15	0	21.38	0-1	1	
	1908.5	19185	3	16-QAM	1	0	21.55	0-1	1	
	1908.5	19185	3	16-QAM	1	7	21.57	0-1	1	
	1908.5	19185	3	16-QAM	1	14	21.48	0-1	1	
	1908.5	19185	3	16-QAM	8	0	20.60	0-2	2	
	1908.5	19185	3	16-QAM	8	4	20.65	0-2	2	
	1908.5	19185	3	16-QAM	8	7	20.79	0-2	2	
	1908.5	19185	3	16-QAM	15	0	20.49	0-2	2	

Table 9-16

LTE Band 2 (PCS) Conducted Powers -1.4 MHz Bandwidth

	Frequency [MHz]	Channel	Bandwidth [MHz]	Modulation	RB Size	RB Offset	Conducted Power [dBm]	MPR Allowed per 3GPP [dB]	MPR [dB]	
Low	1850.7	18607	1.4	QPSK	1	0	22.76	0	0	
	1850.7	18607	1.4	QPSK	1	2	22.46	0	0	
	1850.7	18607	1.4	QPSK	1	5	22.87	0	0	
	1850.7	18607	1.4	QPSK	3	0	22.27	0	0	
	1850.7	18607	1.4	QPSK	3	2	22.60	0	0	
	1850.7	18607	1.4	QPSK	3	3	22.58	0	0	
	1850.7	18607	1.4	QPSK	6	0	21.72	0-1	1	
	1850.7	18607	1.4	16-QAM	1	0	21.47	0-1	1	
	1850.7	18607	1.4	16-QAM	1	2	21.80	0-1	1	
	1850.7	18607	1.4	16-QAM	1	5	21.72	0-1	1	
	1850.7	18607	1.4	16-QAM	3	0	21.81	0-1	1	
	1850.7	18607	1.4	16-QAM	3	2	21.41	0-1	1	
	1850.7	18607	1.4	16-QAM	3	3	21.57	0-1	1	
	1850.7	18607	1.4	16-QAM	6	0	20.49	0-2	2	
	Mid	1880.0	18900	1.4	QPSK	1	0	22.81	0	0
		1880.0	18900	1.4	QPSK	1	2	22.56	0	0
		1880.0	18900	1.4	QPSK	1	5	22.83	0	0
		1880.0	18900	1.4	QPSK	3	0	22.61	0	0
1880.0		18900	1.4	QPSK	3	2	22.30	0	0	
1880.0		18900	1.4	QPSK	3	3	22.28	0	0	
1880.0		18900	1.4	QPSK	6	0	21.54	0-1	1	
1880.0		18900	1.4	16-QAM	1	0	21.32	0-1	1	
1880.0		18900	1.4	16-QAM	1	2	21.40	0-1	1	
1880.0		18900	1.4	16-QAM	1	5	21.68	0-1	1	
1880.0		18900	1.4	16-QAM	3	0	21.74	0-1	1	
1880.0		18900	1.4	16-QAM	3	2	21.65	0-1	1	
1880.0		18900	1.4	16-QAM	3	3	21.65	0-1	1	
1880.0		18900	1.4	16-QAM	6	0	20.38	0-2	2	
High		1909.3	19193	1.4	QPSK	1	0	22.67	0	0
		1909.3	19193	1.4	QPSK	1	2	22.48	0	0
		1909.3	19193	1.4	QPSK	1	5	22.33	0	0
		1909.3	19193	1.4	QPSK	3	0	22.40	0	0
	1909.3	19193	1.4	QPSK	3	2	22.63	0	0	
	1909.3	19193	1.4	QPSK	3	3	22.78	0	0	
	1909.3	19193	1.4	QPSK	6	0	21.39	0-1	1	
	1909.3	19193	1.4	16-QAM	1	0	21.55	0-1	1	
	1909.3	19193	1.4	16-QAM	1	2	21.65	0-1	1	
	1909.3	19193	1.4	16-QAM	1	5	21.73	0-1	1	
	1909.3	19193	1.4	16-QAM	3	0	21.80	0-1	1	
	1909.3	19193	1.4	16-QAM	3	2	21.46	0-1	1	
	1909.3	19193	1.4	16-QAM	3	3	21.71	0-1	1	
	1909.3	19193	1.4	16-QAM	6	0	20.68	0-2	2	

9.4 WLAN Conducted Powers

Table 9-17
IEEE 802.11b Average RF Power – Antenna 1

Mode	Freq [MHz]	Channel	802.11b Conducted Power [dBm]			
			Data Rate [Mbps]			
			1	2	5.5	11
802.11b	2412	1*	16.95	17.26	17.27	17.22
802.11b	2437	6*	17.20	17.42	17.37	17.30
802.11b	2462	11*	16.60	16.81	16.83	16.91

Table 9-18
IEEE 802.11b Average RF Power – Antenna 2

Mode	Freq [MHz]	Channel	802.11b Conducted Power [dBm]			
			Data Rate [Mbps]			
			1	2	5.5	11
802.11b	2412	1*	17.33	16.50	16.53	16.54
802.11b	2437	6*	16.89	16.10	16.09	16.12
802.11b	2462	11*	17.31	16.48	16.44	16.50

Table 9-19
IEEE 802.11g Average RF Power – Antenna 1

Mode	Freq [MHz]	Channel	802.11g Conducted Power [dBm]							
			Data Rate [Mbps]							
			6	9	12	18	24	36	48	54
802.11g	2412	1	14.26	14.19	14.21	14.12	14.41	14.34	14.49	14.37
802.11g	2437	6	13.65	13.48	13.57	13.50	13.76	13.73	13.93	13.64
802.11g	2462	11	13.92	13.85	13.91	13.75	14.13	14.02	14.23	14.05



FCC ID: A3LSMN915G	 PCTEST PROVIDING UNPRECEDENTED	SAR EVALUATION REPORT		Reviewed by: Quality Manager
Document S/N: OY1408121709.A3L	Test Dates: 08/14/14 - 08/18/14	DUT Type: Portable Handset		Page 34 of 73

Table 9-20
IEEE 802.11g Average RF Power – Antenna 2

Mode	Freq [MHz]	Channel	802.11g Conducted Power [dBm]							
			Data Rate [Mbps]							
			6	9	12	18	24	36	48	54
802.11g	2412	1	14.32	14.34	14.27	14.33	14.48	14.45	13.74	13.64
802.11g	2437	6	13.89	13.93	13.83	13.91	14.04	14.07	13.33	13.16
802.11g	2462	11	14.14	14.16	14.12	14.17	14.27	14.29	13.62	13.39

Table 9-21
IEEE 802.11n Average RF Power – Antenna 1

Mode	Freq [MHz]	Channel	802.11n (2.4GHz) Conducted Power [dBm]							
			Data Rate [Mbps]							
			6.5	13	19.5	26	39	52	58.5	65
802.11n	2412	1	13.14	13.16	13.17	13.44	13.45	13.43	13.48	13.43
802.11n	2437	6	12.60	12.47	12.59	12.77	12.85	12.78	12.80	12.76
802.11n	2462	11	13.11	13.07	13.06	13.30	13.37	13.27	13.35	13.25

Table 9-22
IEEE 802.11n Average RF Power – Antenna 2

Mode	Freq [MHz]	Channel	802.11n (2.4GHz) Conducted Power [dBm]							
			Data Rate [Mbps]							
			6.5	13	19.5	26	39	52	58.5	65
802.11n	2412	1	13.20	13.23	13.10	13.43	13.39	13.43	13.48	13.46
802.11n	2437	6	12.80	12.83	12.72	13.03	13.01	13.04	13.15	12.99
802.11n	2462	11	13.06	13.12	12.94	13.20	13.20	13.35	13.30	13.33

Table 9-23
IEEE 802.11n Average RF Power – MIMO

Mode	Freq [MHz]	Channel	Data Rate (Mbps)
			13
802.11n	2412	1	16.18
802.11n	2437	6	15.71
802.11n	2462	11	16.10





FCC ID: A3LSMN915G		SAR EVALUATION REPORT		Reviewed by: Quality Manager
Document S/N: OY1408121709.A3L	Test Dates: 08/14/14 - 08/18/14	DUT Type: Portable Handset		Page 35 of 73

Table 9-24
IEEE 802.11a Average RF Power – Antenna 1

Mode	Freq [MHz]	Channel	802.11a Conducted Power [dBm]							
			Data Rate [Mbps]							
			6	9	12	18	24	36	48	54
802.11a	5180	36*	13.63	13.42	13.53	13.39	13.74	13.67	13.85	13.56
802.11a	5200	40	13.62	13.41	13.43	13.30	13.75	13.74	13.86	13.59
802.11a	5220	44	13.58	13.36	13.52	13.38	13.63	13.66	13.80	13.52
802.11a	5240	48*	13.47	13.17	13.35	13.16	13.60	13.52	13.67	13.42
802.11a	5260	52*	13.98	13.76	13.84	13.78	14.01	13.99	14.17	13.91
802.11a	5280	56	13.92	13.66	13.75	13.72	13.95	13.95	14.05	13.91
802.11a	5300	60	13.86	13.64	13.64	13.63	13.93	13.93	14.05	13.81
802.11a	5320	64*	13.82	13.57	13.65	13.58	13.87	13.80	13.96	13.70
802.11a	5500	100	13.65	13.50	13.57	13.53	13.72	13.71	13.85	13.69
802.11a	5520	104*	13.62	13.43	13.51	13.48	13.74	13.68	13.83	13.62
802.11a	5540	108	13.61	13.48	13.52	13.47	13.64	13.70	13.73	13.64
802.11a	5560	112	13.58	13.51	13.49	13.45	13.72	13.64	13.78	13.70
802.11a	5580	116*	13.54	13.31	13.45	13.44	13.59	13.54	13.69	13.63
802.11a	5600	120	N/A	N/A	N/A	N/A	N/A	N/A	N/A	N/A
802.11a	5620	124	N/A	N/A	N/A	N/A	N/A	N/A	N/A	N/A
802.11a	5640	128	N/A	N/A	N/A	N/A	N/A	N/A	N/A	N/A
802.11a	5660	132	13.51	13.32	13.49	13.38	13.60	13.62	13.75	13.51
802.11a	5680	136*	13.45	13.26	13.43	13.30	13.57	13.47	13.69	13.47
802.11a	5700	140	13.53	13.47	13.40	13.45	13.67	13.53	13.80	13.55
802.11a	5745	149*	13.58	13.53	13.58	13.48	13.66	13.64	13.80	13.60
802.11a	5765	153	13.57	13.57	13.61	13.52	13.74	13.69	13.65	13.64
802.11a	5785	157*	13.55	13.50	13.50	13.43	13.60	13.57	13.76	13.57
802.11a	5805	161	13.55	13.46	13.55	13.44	13.62	13.60	13.81	13.65
802.11a	5825	165*	13.55	13.47	13.59	13.46	13.61	13.68	13.80	13.55

Per FCC KDB Publication 443999 and RSS-210 A9.2(3), transmission on channels which overlap the 5600-5650 MHz is prohibited as a client. This device does not transmit any beacons or initiate any transmissions in 5.3 and 5.5 GHz Band.

(*) – indicates default channels per KDB Publication 248227 D01v01r02. When the adjacent channels are higher in power than the default channels, these “required channels” are considered for SAR testing instead of the default channels.

FCC ID: A3LSMN915G		SAR EVALUATION REPORT		Reviewed by: Quality Manager
Document S/N: OY1408121709.A3L	Test Dates: 08/14/14 - 08/18/14	DUT Type: Portable Handset	Page 36 of 73	

**Table 9-25
IEEE 802.11a Average RF Power – Antenna 2**

Mode	Freq [MHz]	Channel	802.11a Conducted Power [dBm]							
			Data Rate [Mbps]							
			6	9	12	18	24	36	48	54
802.11a	5180	36*	14.14	14.00	14.05	14.09	14.25	14.15	14.38	14.23
802.11a	5200	40	13.90	13.71	13.84	13.89	14.09	13.92	14.19	13.92
802.11a	5220	44	13.97	13.83	13.91	13.90	14.05	14.06	14.20	14.05
802.11a	5240	48*	13.75	13.66	13.72	13.71	13.85	13.79	13.96	13.77
802.11a	5260	52*	13.70	13.58	13.60	13.58	13.75	13.67	13.90	13.76
802.11a	5280	56	13.54	13.46	13.48	13.38	13.57	13.55	13.77	13.62
802.11a	5300	60	13.52	13.36	13.39	13.41	13.59	13.53	13.64	13.62
802.11a	5320	64*	13.42	13.36	13.24	13.30	13.53	13.38	13.58	13.51
802.11a	5500	100	13.60	13.52	13.56	13.58	13.70	13.61	13.82	13.67
802.11a	5520	104*	13.41	13.35	13.42	13.36	13.51	13.50	13.59	13.45
802.11a	5540	108	13.48	13.41	13.48	13.50	13.55	13.44	13.61	13.57
802.11a	5560	112	13.44	13.39	13.34	13.38	13.59	13.53	13.74	13.47
802.11a	5580	116*	13.40	13.38	13.35	13.43	13.42	13.40	13.55	13.41
802.11a	5600	120	N/A	N/A	N/A	N/A	N/A	N/A	N/A	N/A
802.11a	5620	124	N/A	N/A	N/A	N/A	N/A	N/A	N/A	N/A
802.11a	5640	128	N/A	N/A	N/A	N/A	N/A	N/A	N/A	N/A
802.11a	5660	132	13.40	13.30	13.36	13.37	13.43	13.34	13.61	13.44
802.11a	5680	136*	13.36	13.28	13.41	13.31	13.43	13.43	13.50	13.49
802.11a	5700	140	14.21	14.13	14.20	14.16	14.36	14.26	14.36	14.20
802.11a	5745	149*	14.09	14.18	14.12	14.15	14.26	14.16	14.30	14.29
802.11a	5765	153	14.15	14.20	14.12	14.18	14.29	14.23	14.34	14.36
802.11a	5785	157*	14.10	14.21	14.15	14.09	14.28	14.16	14.36	14.32
802.11a	5805	161	14.06	14.16	14.12	14.07	14.21	14.08	14.35	14.33
802.11a	5825	165*	14.22	14.34	14.22	14.19	14.46	14.37	14.41	14.38

Per FCC KDB Publication 443999 and RSS-210 A9.2(3), transmission on channels which overlap the 5600-5650 MHz is prohibited as a client. This device does not transmit any beacons or initiate any transmissions in 5.3 and 5.5 GHz Band.

(*) – indicates default channels per KDB Publication 248227 D01v01r02. When the adjacent channels are higher in power then the default channels, these “required channels” are considered for SAR testing instead of the default channels.



FCC ID: A3LSMN915G		SAR EVALUATION REPORT		Reviewed by: Quality Manager
Document S/N: OY1408121709.A3L	Test Dates: 08/14/14 - 08/18/14	DUT Type: Portable Handset	Page 37 of 73	

Table 9-26
IEEE 802.11n Average RF Power – 20 MHz Bandwidth – Antenna 1

Mode	Freq [MHz]	Channel	20MHz BW 802.11n (5GHz) Conducted Power [dBm]							
			Data Rate [Mbps]							
			6.5	13	19.5	26	39	52	58.5	65
802.11n	5180	36	13.01	13.01	13.02	13.18	13.21	13.20	13.28	13.21
802.11n	5200	40	13.02	13.01	13.03	13.19	13.16	13.17	13.24	13.27
802.11n	5220	44	12.99	12.99	12.98	13.16	13.20	13.14	13.19	13.26
802.11n	5240	48	12.87	12.78	12.89	13.01	13.09	13.08	13.18	13.01
802.11n	5260	52	13.09	13.02	12.99	13.28	13.28	13.24	13.28	13.30
802.11n	5280	56	13.06	13.00	12.95	13.22	13.26	13.19	13.29	13.28
802.11n	5300	60	13.06	13.02	13.04	13.24	13.21	13.21	13.23	13.24
802.11n	5320	64	12.91	12.85	12.89	13.13	13.05	13.08	13.12	13.05
802.11n	5500	100	12.52	12.43	12.43	12.67	12.71	12.66	12.68	12.68
802.11n	5520	104	12.42	12.26	12.31	12.58	12.60	12.60	12.61	12.54
802.11n	5540	108	12.43	12.30	12.31	12.55	12.59	12.56	12.61	12.58
802.11n	5560	112	12.45	12.44	12.37	12.54	12.62	12.61	12.64	12.63
802.11n	5580	116	12.43	12.34	12.39	12.63	12.60	12.60	12.54	12.55
802.11n	5600	120	N/A	N/A	N/A	N/A	N/A	N/A	N/A	N/A
802.11n	5620	124	N/A	N/A	N/A	N/A	N/A	N/A	N/A	N/A
802.11n	5640	128	N/A	N/A	N/A	N/A	N/A	N/A	N/A	N/A
802.11n	5660	132	12.37	12.29	12.29	12.47	12.58	12.44	12.51	12.54
802.11n	5680	136	12.41	12.36	12.36	12.55	12.67	12.56	12.64	12.57
802.11n	5700	140	12.33	12.18	12.28	12.48	12.57	12.52	12.53	12.53
802.11n	5745	149	12.72	12.74	12.72	13.03	12.99	12.95	13.02	12.97
802.11n	5765	153	12.72	12.79	12.78	13.03	12.97	13.03	13.07	12.96
802.11n	5785	157	12.73	12.80	12.67	13.01	12.94	13.00	12.96	13.04
802.11n	5805	161	12.80	12.84	12.71	13.12	13.08	13.08	13.14	13.01
802.11n	5825	165	12.77	12.81	12.84	13.12	12.98	12.98	13.08	13.02



FCC ID: A3LSMN915G	 SAR EVALUATION REPORT 	Reviewed by: Quality Manager
Document S/N: OY1408121709.A3L	Test Dates: 08/14/14 - 08/18/14	DUT Type: Portable Handset
		Page 38 of 73

Table 9-27
IEEE 802.11n Average RF Power – 20 MHz Bandwidth – Antenna 2

Mode	Freq [MHz]	Channel	20MHz BW 802.11n (5GHz) Conducted Power [dBm]							
			Data Rate [Mbps]							
			6.5	13	19.5	26	39	52	58.5	65
802.11n	5180	36	13.08	13.04	13.09	13.25	13.29	13.15	13.29	13.28
802.11n	5200	40	13.15	13.09	13.13	13.32	13.36	13.27	13.40	13.37
802.11n	5220	44	12.87	12.87	12.93	13.03	13.09	12.95	13.09	13.07
802.11n	5240	48	12.99	12.91	13.01	13.12	13.14	13.12	13.15	13.18
802.11n	5260	52	12.66	12.55	12.58	12.75	12.76	12.81	12.79	12.84
802.11n	5280	56	12.56	12.40	12.39	12.72	12.71	12.71	12.69	12.73
802.11n	5300	60	12.50	12.44	12.47	12.57	12.60	12.65	12.68	12.61
802.11n	5320	64	13.29	13.15	13.29	13.32	13.43	13.46	13.37	13.43
802.11n	5500	100	12.60	12.65	12.60	12.83	12.81	12.71	12.83	12.78
802.11n	5520	104	12.63	12.74	12.61	12.93	12.83	12.71	12.90	12.80
802.11n	5540	108	12.45	12.49	12.38	12.71	12.67	12.47	12.60	12.64
802.11n	5560	112	12.48	12.47	12.47	12.71	12.74	12.52	12.77	12.69
802.11n	5580	116	12.51	12.54	12.48	12.73	12.74	12.63	12.67	12.65
802.11n	5600	120	N/A	N/A	N/A	N/A	N/A	N/A	N/A	N/A
802.11n	5620	124	N/A	N/A	N/A	N/A	N/A	N/A	N/A	N/A
802.11n	5640	128	N/A	N/A	N/A	N/A	N/A	N/A	N/A	N/A
802.11n	5660	132	12.40	12.45	12.36	12.62	12.63	12.49	12.59	12.60
802.11n	5680	136	12.38	12.44	12.35	12.57	12.66	12.46	12.60	12.55
802.11n	5700	140	12.54	12.58	12.54	12.80	12.73	12.67	12.77	12.68
802.11n	5745	149	13.28	13.06	13.13	13.32	13.40	13.32	13.36	13.39
802.11n	5765	153	13.31	13.05	13.16	13.31	13.42	13.35	13.37	13.38
802.11n	5785	157	13.11	12.91	12.91	13.16	13.29	13.17	13.12	13.21
802.11n	5805	161	13.10	12.87	12.91	13.16	13.20	13.06	13.14	13.21
802.11n	5825	165	13.13	13.00	12.98	13.25	13.24	13.16	13.23	13.25



FCC ID: A3LSMN915G	 PCTEST <small>PROVIDING LABORATORY, INC.</small>	SAR EVALUATION REPORT		Reviewed by: Quality Manager
Document S/N: OY1408121709.A3L	Test Dates: 08/14/14 - 08/18/14	DUT Type: Portable Handset	Page 39 of 73	

Table 9-28
IEEE 802.11n Average RF Power – 20 MHz Bandwidth – MIMO

Mode	Freq [MHz]	Channel	Data Rate (Mbps)
			13
802.11n	5180	36	12.55
802.11n	5200	40	12.59
802.11n	5220	44	12.46
802.11n	5240	48	12.43
802.11n	5260	52	12.30
802.11n	5280	56	12.25
802.11n	5300	60	12.23
802.11n	5320	64	12.44
802.11n	5500	100	12.63
802.11n	5520	104	12.57
802.11n	5540	108	12.52
802.11n	5560	112	12.54
802.11n	5580	116	12.54
802.11n	5600	120	N/A
802.11n	5620	124	N/A
802.11n	5640	128	N/A
802.11n	5660	132	12.47
802.11n	5680	136	12.48
802.11n	5700	140	12.49
802.11n	5745	149	12.99
802.11n	5765	153	13.01
802.11n	5785	157	12.94
802.11n	5805	161	12.98
802.11n	5825	165	12.98



FCC ID: A3LSMN915G	 PCTEST <small>PROVIDING EXCELLENCE</small>	SAR EVALUATION REPORT		Reviewed by: Quality Manager
Document S/N: OY1408121709.A3L	Test Dates: 08/14/14 - 08/18/14	DUT Type: Portable Handset	Page 40 of 73	

Table 9-29
IEEE 802.11n Average RF Power – 40 MHz Bandwidth – Antenna 1

Mode	Freq [MHz]	Channel	40MHz BW 802.11n (5GHz) Conducted Power [dBm]							
			Data Rate [Mbps]							
			13.5	27	40.5	54	81	108	121.5	135
802.11n	5190	38	12.21	12.23	12.28	12.44	12.45	12.47	12.49	12.40
802.11n	5230	46	12.04	11.99	12.09	12.23	12.27	12.30	12.33	12.25
802.11n	5270	54	12.14	12.22	12.30	12.37	12.45	12.34	12.44	12.45
802.11n	5310	62	12.08	12.22	12.21	12.26	12.42	12.26	12.40	12.41
802.11n	5510	102	11.90	11.91	11.90	12.09	12.14	12.13	12.18	12.14
802.11n	5550	110	11.90	11.90	11.83	12.09	12.14	12.13	12.17	12.06
802.11n	5590	118	N/A	N/A	N/A	N/A	N/A	N/A	N/A	N/A
802.11n	5630	126	N/A	N/A	N/A	N/A	N/A	N/A	N/A	N/A
802.11n	5670	134	11.77	11.72	11.80	12.02	11.98	11.98	11.99	11.99
802.11n	5755	151	11.91	11.88	11.76	12.12	12.03	12.10	12.09	12.03
802.11n	5795	159	11.86	11.82	11.71	12.09	12.01	12.06	12.01	12.03

Table 9-30
IEEE 802.11n Average RF Power – 40 MHz Bandwidth – Antenna 2

Mode	Freq [MHz]	Channel	40MHz BW 802.11n (5GHz) Conducted Power [dBm]							
			Data Rate [Mbps]							
			13.5	27	40.5	54	81	108	121.5	135
802.11n	5190	38	11.64	11.70	11.60	11.80	11.81	11.78	11.83	11.84
802.11n	5230	46	11.51	11.60	11.53	11.73	11.67	11.65	11.65	11.68
802.11n	5270	54	12.13	12.08	12.09	12.22	12.18	12.21	12.23	12.17
802.11n	5310	62	12.16	12.13	12.08	12.27	12.21	12.21	12.31	12.19
802.11n	5510	102	12.08	12.21	12.17	12.22	12.33	12.28	12.27	12.22
802.11n	5550	110	12.05	12.13	12.12	12.19	12.25	12.24	12.23	12.19
802.11n	5590	118	N/A	N/A	N/A	N/A	N/A	N/A	N/A	N/A
802.11n	5630	126	N/A	N/A	N/A	N/A	N/A	N/A	N/A	N/A
802.11n	5670	134	11.98	12.11	12.02	12.11	12.22	12.24	12.18	12.14
802.11n	5755	151	11.75	11.72	11.60	11.86	11.88	11.87	11.90	11.84
802.11n	5795	159	11.73	11.73	11.58	11.80	11.91	11.86	11.95	11.81



FCC ID: A3LSMN915G		SAR EVALUATION REPORT		Reviewed by: Quality Manager
Document S/N: OY1408121709.A3L	Test Dates: 08/14/14 - 08/18/14	DUT Type: Portable Handset		Page 41 of 73

Table 9-31
IEEE 802.11n Average RF Power – 40 MHz Bandwidth – MIMO

Mode	Freq [MHz]	Channel	Data Rate (Mbps)
			27
802.11n	5190	38	11.65
802.11n	5230	46	11.49
802.11n	5270	54	11.81
802.11n	5310	62	11.79
802.11n	5510	102	11.65
802.11n	5550	110	11.64
802.11n	5590	118	N/A
802.11n	5630	126	N/A
802.11n	5670	134	11.54
802.11n	5755	151	11.52
802.11n	5795	159	11.48

Table 9-32
IEEE 802.11ac Average RF Power – 80 MHz Bandwidth – Antenna 1

Mode	Freq [MHz]	Channel	80MHz BW 802.11ac (5GHz) Conducted Power [dBm]									
			Data Rate [Mbps]									
			29.3	58.5	87.8	117	175.5	234	263.3	292.5	351	390
802.11ac	5210	42	11.05	10.91	10.80	10.41	10.45	10.41	10.42	10.46	11.28	10.50
802.11ac	5290	58	10.56	10.73	10.02	10.53	10.65	10.71	10.66	10.63	10.51	10.61
802.11ac	5530	106	10.90	11.08	11.06	10.48	10.92	10.93	11.10	11.06	11.01	11.08
802.11ac	5775	155	10.76	10.85	10.66	10.92	10.99	10.98	10.99	10.74	10.99	10.96

Table 9-33
IEEE 802.11ac Average RF Power – 80 MHz Bandwidth – Antenna 2

Mode	Freq [MHz]	Channel	80MHz BW 802.11ac (5GHz) Conducted Power [dBm]									
			Data Rate [Mbps]									
			29.3	58.5	87.8	117	175.5	234	263.3	292.5	351	390
802.11ac	5210	42	11.11	11.09	10.97	10.51	10.56	10.61	10.61	10.59	10.50	10.65
802.11ac	5290	58	10.70	10.68	10.45	10.92	10.92	10.92	10.91	10.88	10.94	10.94
802.11ac	5530	106	10.73	10.58	10.45	10.92	10.94	10.83	10.83	10.84	10.92	10.96
802.11ac	5775	155	11.19	11.04	11.07	10.64	10.73	10.52	10.50	10.60	10.61	10.58



FCC ID: A3LSMN915G		SAR EVALUATION REPORT		Reviewed by: Quality Manager
Document S/N: OY1408121709.A3L	Test Dates: 08/14/14 - 08/18/14	DUT Type: Portable Handset		Page 42 of 73

Table 9-34
IEEE 802.11ac Average RF Power – 80 MHz Bandwidth – MIMO

Mode	Freq [MHz]	Channel	Data Rate (Mbps)
			58.5
802.11ac	5210	42	10.95
802.11ac	5290	58	10.97
802.11ac	5530	106	11.18
802.11ac	5775	155	11.29

Justification for reduced test configurations for WIFI channels per KDB Publication 248227 D01v01r02 and October 2012/April 2013 FCC/TCB Meeting Notes:

- For 2.4 GHz SISO operations, highest average RF output power channel for the lowest data rate for IEEE 802.11b were selected for SAR evaluation. Other IEEE 802.11 SISO modes (including 802.11g/n) were not investigated since the average output powers over all channels and data rates were not more than 0.25 dB higher than the tested channel in the lowest data rate of IEEE 802.11b mode.
- For 5 GHz SISO operations, highest average RF output power channel for the lowest data rate for IEEE 802.11a were selected for SAR evaluation. Other IEEE 802.11 SISO modes (including 802.11n 20 MHz and 40 MHz) were not investigated since the average output powers over all channels and data rates were not more than 0.25 dB higher than the tested channel in the lowest data rate of IEEE 802.11a mode.
- Full SAR tests for all SISO IEEE 802.11ac configurations were not required because the average output power was not more than 0.25 dB higher than IEEE 802.11a mode. IEEE 802.11ac in SISO mode was evaluated for the highest IEEE 802.11a position in each 5 GHz band and exposure condition.
- For MIMO 2.4 GHz and 5 GHz operations, the highest average RF output power channel for the lowest data rate for IEEE 802.11n (20 MHz bandwidth) was selected for SAR evaluation. Other IEEE 802.11 modes and bandwidths were not investigated for MIMO operations since the maximum allowed output power (including tolerance) was not higher for these modes.
- The individual spectra for each 2x2 MIMO WIFI Antenna were summed mathematically in linear power units for the MIMO output power measurements.
- When the maximum extrapolated peak SAR of the zoom scan for the maximum output channel is <1.6 W/kg and the reported 1g averaged SAR is <0.8 W/kg, SAR testing on other channels is not required. Otherwise, the other default (or corresponding required) test channels were additionally tested using the lowest data rate.
- The bolded data rate and channel above were tested for SAR.

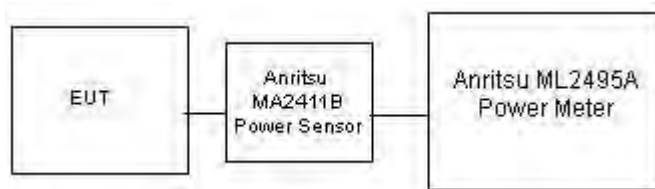

Figure 9-3
Power Measurement Setup for Bandwidths < 50 MHz

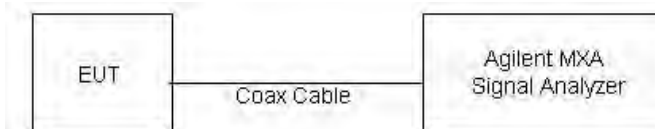



Figure 9-4
Power Measurement Setup for Bandwidths > 50 MHz

FCC ID: A3LSMN915G		SAR EVALUATION REPORT		Reviewed by: Quality Manager
Document S/N: OY1408121709.A3L	Test Dates: 08/14/14 - 08/18/14	DUT Type: Portable Handset	Page 43 of 73	



10 SYSTEM VERIFICATION

10.1 Tissue Verification

**Table 10-1
Measured Tissue Properties**

Calibrated for Tests Performed on:	Tissue Type	Tissue Temp During Calibration (C°)	Measured Frequency (MHz)	Measured Conductivity, σ (S/m)	Measured Dielectric Constant, ϵ	TARGET Conductivity, σ (S/m)	TARGET Dielectric Constant, ϵ	% dev σ	% dev ϵ
8/15/2014	835H	20.3	820	0.894	42.363	0.899	41.578	-0.56%	1.89%
			835	0.911	42.176	0.900	41.500	1.22%	1.63%
			850	0.927	42.007	0.916	41.500	1.20%	1.22%
8/18/2014	835H	19.9	820	0.906	42.108	0.899	41.578	0.78%	1.27%
			835	0.922	41.944	0.900	41.500	2.44%	1.07%
			850	0.938	41.716	0.916	41.500	2.40%	0.52%
8/18/2014	1750H	23.0	1710	1.315	39.192	1.348	40.142	-2.45%	-2.37%
			1750	1.357	39.027	1.371	40.079	-1.02%	-2.62%
			1790	1.393	38.805	1.394	40.016	-0.07%	-3.03%
8/14/2014	1900H	20.4	1850	1.361	41.287	1.400	40.000	-2.79%	3.22%
			1880	1.388	41.100	1.400	40.000	-0.86%	2.75%
			1910	1.422	40.910	1.400	40.000	1.57%	2.27%
8/18/2014	2450H	22.0	2401	1.740	40.746	1.756	39.287	-0.91%	3.71%
			2450	1.790	40.574	1.800	39.200	-0.56%	3.51%
			2499	1.845	40.408	1.853	39.138	-0.43%	3.24%
08/14/2014	5200H-5800H	23.4	5180	4.544	37.113	4.635	36.009	-1.96%	3.07%
			5200	4.567	37.076	4.655	35.986	-1.89%	3.03%
			5220	4.590	37.007	4.676	35.963	-1.84%	2.90%
			5260	4.637	37.018	4.717	35.917	-1.70%	3.07%
			5280	4.648	36.982	4.737	35.894	-1.88%	3.03%
			5300	4.660	36.974	4.758	35.871	-2.06%	3.07%
			5320	4.693	36.897	4.778	35.849	-1.78%	2.92%
			5500	4.671	36.690	4.963	35.643	-1.85%	2.94%
			5520	4.900	36.683	4.983	35.620	-1.67%	2.93%
			5540	4.913	36.639	5.004	35.597	-1.82%	2.93%
			5900	4.976	36.541	5.065	35.529	-1.76%	2.85%
			5700	5.082	36.438	5.168	35.414	-1.66%	2.89%
			5745	5.150	36.373	5.214	35.363	-1.23%	2.86%
			5765	5.162	36.362	5.234	35.340	-1.38%	2.89%
			5785	5.171	36.364	5.255	35.317	-1.60%	2.96%
			5800	5.180	36.307	5.270	35.300	-1.71%	2.85%
			5825	5.210	36.244	5.296	35.271	-1.62%	2.76%
8/14/2014	835B	23.1	820	0.983	53.141	0.969	55.258	1.44%	-3.83%
			835	0.997	53.013	0.970	55.200	2.78%	-3.96%
			850	1.011	52.849	0.988	55.154	2.33%	-4.18%
8/14/2014	1750B	23.8	1710	1.407	52.178	1.463	53.537	-3.83%	-2.54%
			1750	1.448	52.043	1.488	53.432	-2.69%	-2.60%
			1790	1.490	51.876	1.514	53.326	-1.59%	-2.72%
8/14/2014	1900B	21.0	1850	1.493	51.304	1.520	53.300	-1.78%	-3.74%
			1880	1.528	51.168	1.520	53.300	0.53%	-4.00%
			1910	1.568	51.073	1.520	53.300	3.16%	-4.18%
8/14/2014	1900B	22.3	1850	1.456	52.026	1.520	53.300	-4.21%	-2.39%
			1880	1.489	51.908	1.520	53.300	-2.04%	-2.61%
			1910	1.525	51.783	1.520	53.300	0.33%	-2.85%
8/18/2014	1900B	22.2	1850	1.508	51.802	1.520	53.300	-0.79%	-2.81%
			1880	1.544	51.756	1.520	53.300	1.58%	-2.90%
			1910	1.582	51.652	1.520	53.300	4.08%	-3.09%
8/18/2014	2450B	23.2	2401	1.908	52.115	1.903	52.765	0.26%	-1.23%
			2450	1.970	51.945	1.950	52.700	1.03%	-1.43%
			2499	2.037	51.768	2.019	52.638	0.89%	-1.65%
08/18/2014	5200B-5800B	20.5	5180	5.086	47.247	5.276	49.041	-3.60%	-3.66%
			5200	5.106	47.285	5.299	49.014	-3.64%	-3.53%
			5220	5.119	47.231	5.323	48.987	-3.83%	-3.58%
			5260	5.168	47.140	5.369	48.933	-3.74%	-3.66%
			5280	5.210	47.109	5.393	48.906	-3.39%	-3.67%
			5300	5.228	47.061	5.416	48.879	-3.47%	-3.72%
			5320	5.256	47.071	5.439	48.851	-3.36%	-3.64%
			5500	5.509	46.844	5.650	48.607	-2.50%	-3.63%
			5520	5.544	46.831	5.673	48.580	-2.27%	-3.60%
			5540	5.560	46.766	5.696	48.553	-2.39%	-3.68%
			5600	5.653	46.714	5.766	48.471	-1.96%	-3.62%
			5700	5.780	46.550	5.883	48.336	-1.75%	-3.69%
			5745	5.829	46.499	5.936	48.275	-1.80%	-3.68%
			5765	5.845	46.465	5.959	48.248	-1.91%	-3.70%
			5785	5.834	46.393	5.982	48.220	-2.47%	-3.79%
			5800	5.842	46.461	6.000	48.200	-2.63%	-3.61%
			5825	5.890	46.409	6.029	48.166	-2.31%	-3.65%

The above measured tissue parameters were used in the DASY software. The DASY software was used to perform interpolation to determine the dielectric parameters at the SAR test device frequencies (per KDB Publication 865664 and IEEE 1528-2013 6.6.1.2). The tissue parameters listed in the SAR test plots may slightly differ from the table above due to significant digit rounding in the software.



FCC ID: A3LSMN915G		SAR EVALUATION REPORT			Reviewed by: Quality Manager
Document S/N: OY1408121709.A3L	Test Dates: 08/14/14 - 08/18/14	DUT Type: Portable Handset		Page 44 of 73	

10.2 Test System Verification

Prior to SAR assessment, the system is verified to $\pm 10\%$ of the SAR measurement on the reference dipole at the time of calibration by the calibration facility. Full system validation status and result summary can be found in Appendix E.

**Table 10-2
System Verification Results (1g)**

System Verification TARGET & MEASURED												
SAR System #	Tissue Frequency (MHz)	Tissue Type	Date:	Amb. Temp (°C)	Liquid Temp (°C)	Input Power (W)	Dipole SN	Probe SN	Measured SAR _{1g} (W/kg)	1 W Target SAR _{1g} (W/kg)	1 W Normalized SAR _{1g} (W/kg)	Deviation _{1g} (%)
C	835	HEAD	08/15/2014	22.3	20.2	0.100	4d132	3213	0.970	9.270	9.700	4.64%
C	835	HEAD	08/18/2014	23.7	20.0	0.100	4d132	3213	0.951	9.270	9.510	2.59%
D	1750	HEAD	08/18/2014	24.8	23.0	0.100	1008	3263	3.510	36.900	35.100	-4.88%
C	1900	HEAD	08/14/2014	21.8	20.4	0.100	5d148	3213	3.760	40.700	37.600	-7.62%
H	2450	HEAD	08/18/2014	24.5	22.0	0.100	797	3319	5.330	51.800	53.300	2.90%
E	5200	HEAD	08/14/2014	24.4	23.6	0.100	1057	3914	7.540	78.000	75.400	-3.33%
E	5300	HEAD	08/14/2014	24.4	23.6	0.100	1057	3914	8.140	83.000	81.400	-1.93%
E	5500	HEAD	08/14/2014	24.3	23.7	0.100	1057	3914	8.230	84.300	82.300	-2.37%
E	5600	HEAD	08/14/2014	24.2	23.8	0.100	1057	3914	8.180	83.500	81.800	-2.04%
E	5800	HEAD	08/14/2014	24.3	23.6	0.100	1057	3914	7.390	79.300	73.900	-6.81%
D	835	BODY	08/14/2014	23.9	23.1	0.100	4d119	3263	0.912	9.340	9.120	-2.36%
J	1750	BODY	08/14/2014	23.6	23.8	0.100	1008	3332	4.000	37.600	40.000	6.38%
B	1900	BODY	08/14/2014	22.9	21.0	0.100	5d148	3288	4.170	39.300	41.700	6.11%
K	1900	BODY	08/14/2014	24.2	22.3	0.100	5d141	3287	4.180	40.600	41.800	2.96%
B	1900	BODY	08/18/2014	23.0	22.2	0.100	5d148	3288	4.210	39.300	42.100	7.12%
H	2450	BODY	08/18/2014	24.5	23.2	0.100	797	3319	4.930	49.400	49.300	-0.20%
A	5200	BODY	08/18/2014	23.4	21.8	0.100	1007	3920	7.490	72.600	74.900	3.17%
A	5300	BODY	08/18/2014	23.4	21.8	0.100	1007	3920	7.620	74.700	76.200	2.01%
A	5500	BODY	08/18/2014	23.4	21.8	0.100	1007	3920	7.670	75.900	76.700	1.05%
A	5600	BODY	08/18/2014	23.4	21.8	0.100	1007	3920	7.740	77.300	77.400	0.13%
A	5800	BODY	08/18/2014	23.4	21.8	0.100	1007	3920	7.120	72.900	71.200	-2.33%

FCC ID: A3LSMN915G	 PCTEST Engineering Laboratory, Inc.	SAR EVALUATION REPORT		Reviewed by: Quality Manager
Document S/N: OY1408121709.A3L	Test Dates: 08/14/14 - 08/18/14	DUT Type: Portable Handset		Page 45 of 73

**Table 10-3
System Verification Results (10g)**

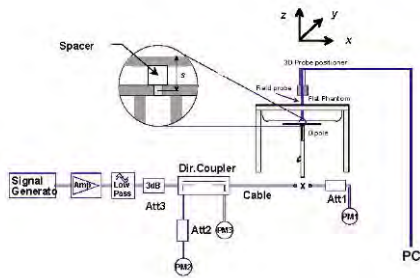

System Verification TARGET & MEASURED												
SAR System #	Tissue Frequency (MHz)	Tissue Type	Date:	Amb. Temp (°C)	Liquid Temp (°C)	Input Power (W)	Dipole SN	Probe SN	Measured SAR _{10g} (W/kg)	1 W Target SAR _{10g} (W/kg)	1 W Normalized SAR _{10g} (W/kg)	Deviation _{10g} (%)
A	5200	BODY	08/18/2014	23.4	21.8	0.100	1007	3920	2.130	20.200	21.300	5.45%
A	5300	BODY	08/18/2014	23.4	21.8	0.100	1007	3920	2.130	20.800	21.300	2.40%
A	5500	BODY	08/18/2014	23.4	21.8	0.100	1007	3920	2.160	21.000	21.600	2.86%
A	5600	BODY	08/18/2014	23.4	21.8	0.100	1007	3920	2.170	21.500	21.700	0.93%
A	5800	BODY	08/18/2014	23.4	21.8	0.100	1007	3920	1.960	20.100	19.600	-2.49%



**Figure 10-1
System Verification Setup Diagram**



**Figure 10-2
System Verification Setup Photo**

FCC ID: A3LSMN915G		SAR EVALUATION REPORT		Reviewed by: Quality Manager
Document S/N: OY1408121709.A3L	Test Dates: 08/14/14 - 08/18/14	DUT Type: Portable Handset	Page 46 of 73	

11 SAR DATA SUMMARY

11.1 Standalone Head SAR Data

**Table 11-1
GSM 850 Head SAR**



MEASUREMENT RESULTS														
FREQUENCY		Mode/Band	Service	Maximum Allowed Power [dBm]	Conducted Power [dBm]	Power Drift [dB]	Side	Test Position	Device Serial Number	Duty Cycle	SAR (1g)	Scaling Factor	Scaled SAR (1g)	Plot #
MHz	Ch.										(W/kg)		(W/kg)	
836.60	190	GSM850	GSM	33.5	32.80	0.17	Right	Cheek	F238A	1:8.3	0.067	1.175	0.079	A1
836.60	190	GSM850	GSM	33.5	32.80	0.17	Right	Tilt	F238A	1:8.3	0.036	1.175	0.042	
836.60	190	GSM850	GSM	33.5	32.80	0.07	Left	Cheek	F238A	1:8.3	0.053	1.175	0.062	
836.60	190	GSM850	GSM	33.5	32.80	0.12	Left	Tilt	F238A	1:8.3	0.029	1.175	0.034	
ANSI / IEEE C95.1 1992 - SAFETY LIMIT Spatial Peak Uncontrolled Exposure/General Population							Head 1.6 W/kg (mW/g) averaged over 1 gram							

**Table 11-2
GSM 1900 Head SAR**

MEASUREMENT RESULTS														
FREQUENCY		Mode/Band	Service	Maximum Allowed Power [dBm]	Conducted Power [dBm]	Power Drift [dB]	Side	Test Position	Device Serial Number	Duty Cycle	SAR (1g)	Scaling Factor	Scaled SAR (1g)	Plot #
MHz	Ch.										(W/kg)		(W/kg)	
1880.00	661	GSM 1900	GSM	30.0	29.54	0.15	Right	Cheek	F227C	1:8.3	0.131	1.112	0.146	A2
1880.00	661	GSM 1900	GSM	30.0	29.54	-0.09	Right	Tilt	F227C	1:8.3	0.076	1.112	0.085	
1880.00	661	GSM 1900	GSM	30.0	29.54	0.20	Left	Cheek	F227C	1:8.3	0.065	1.112	0.072	
1880.00	661	GSM 1900	GSM	30.0	29.54	-0.13	Left	Tilt	F227C	1:8.3	0.018	1.112	0.020	
ANSI / IEEE C95.1 1992 - SAFETY LIMIT Spatial Peak Uncontrolled Exposure/General Population							Head 1.6 W/kg (mW/g) averaged over 1 gram							

**Table 11-3
UMTS 850 Head SAR**

MEASUREMENT RESULTS														
FREQUENCY		Mode/Band	Service	Maximum Allowed Power [dBm]	Conducted Power [dBm]	Power Drift [dB]	Side	Test Position	Device Serial Number	Duty Cycle	SAR (1g)	Scaling Factor	Scaled SAR (1g)	Plot #
MHz	Ch.										(W/kg)		(W/kg)	
836.60	4183	UMTS 850	RMC	24.0	23.40	0.03	Right	Cheek	F227C	1:1	0.116	1.148	0.133	A3
836.60	4183	UMTS 850	RMC	24.0	23.40	0.02	Right	Tilt	F227C	1:1	0.054	1.148	0.062	
836.60	4183	UMTS 850	RMC	24.0	23.40	0.03	Left	Cheek	F227C	1:1	0.068	1.148	0.078	
836.60	4183	UMTS 850	RMC	24.0	23.40	0.01	Left	Tilt	F227C	1:1	0.040	1.148	0.046	
ANSI / IEEE C95.1 1992 - SAFETY LIMIT Spatial Peak Uncontrolled Exposure/General Population							Head 1.6 W/kg (mW/g) averaged over 1 gram							

FCC ID: A3LSMN915G	 PCTEST PROVIDING EXCELLENCE,™	SAR EVALUATION REPORT		Reviewed by: Quality Manager
Document S/N: OY1408121709.A3L	Test Dates: 08/14/14 - 08/18/14	DUT Type: Portable Handset		Page 47 of 73

**Table 11-4
UMTS 1900 Head SAR**



MEASUREMENT RESULTS														
FREQUENCY		Mode/Band	Service	Maximum Allowed Power [dBm]	Conducted Power [dBm]	Power Drift [dB]	Side	Test Position	Device Serial Number	Duty Cycle	SAR (1g)	Scaling Factor	Scaled SAR (1g)	Plot #
MHz	Ch.										(W/kg)		(W/kg)	
1880.00	9400	UMTS 1900	RMC	23.0	22.70	0.20	Right	Cheek	F227C	1:1	0.232	1.072	0.249	A4
1880.00	9400	UMTS 1900	RMC	23.0	22.70	0.11	Right	Tilt	F227C	1:1	0.137	1.072	0.147	
1880.00	9400	UMTS 1900	RMC	23.0	22.70	0.11	Left	Cheek	F227C	1:1	0.080	1.072	0.086	
1880.00	9400	UMTS 1900	RMC	23.0	22.70	0.06	Left	Tilt	F227C	1:1	0.030	1.072	0.032	
ANSI / IEEE C95.1 1992 - SAFETY LIMIT Spatial Peak Uncontrolled Exposure/General Population							Head 1.6 W/kg (mW/g) averaged over 1 gram							

**Table 11-5
LTE Band 5 (Cell) Head SAR**

MEASUREMENT RESULTS																			
FREQUENCY		Mode	Bandwidth [MHz]	Maximum Allowed Power [dBm]	Conducted Power [dBm]	Power Drift [dB]	MPR [dB]	Side	Test Position	Modulation	RB Size	RB Offset	Device Serial Number	Duty Cycle	SAR (1g)	Scaling Factor	Scaled SAR (1g)	Plot #	
MHz	Ch.														(W/kg)		(W/kg)		
836.50	20525	Mid	LTE Band 5 (Cell)	10	23.5	22.70	0.13	0	Right	Cheek	QPSK	1	0	F238A	1:1	0.076	1.202	0.091	
836.50	20525	Mid	LTE Band 5 (Cell)	10	22.5	21.69	-0.14	1	Right	Cheek	QPSK	25	0	F238A	1:1	0.079	1.205	0.095	A5
836.50	20525	Mid	LTE Band 5 (Cell)	10	23.5	22.70	0.13	0	Right	Tilt	QPSK	1	0	F238A	1:1	0.013	1.202	0.016	
836.50	20525	Mid	LTE Band 5 (Cell)	10	22.5	21.69	0.11	1	Right	Tilt	QPSK	25	0	F238A	1:1	0.031	1.205	0.037	
836.50	20525	Mid	LTE Band 5 (Cell)	10	23.5	22.70	-0.11	0	Left	Cheek	QPSK	1	0	F238A	1:1	0.046	1.202	0.055	
836.50	20525	Mid	LTE Band 5 (Cell)	10	22.5	21.69	0.17	1	Left	Cheek	QPSK	25	0	F238A	1:1	0.044	1.205	0.053	
836.50	20525	Mid	LTE Band 5 (Cell)	10	23.5	22.70	-0.01	0	Left	Tilt	QPSK	1	0	F238A	1:1	0.027	1.202	0.032	
836.50	20525	Mid	LTE Band 5 (Cell)	10	22.5	21.69	0.06	1	Left	Tilt	QPSK	25	0	F238A	1:1	0.025	1.205	0.030	
ANSI / IEEE C95.1 1992 - SAFETY LIMIT Spatial Peak Uncontrolled Exposure/General Population									Head 1.6 W/kg (mW/g) averaged over 1 gram										

**Table 11-6
LTE Band 4 (AWS) Head SAR**

MEASUREMENT RESULTS																			
FREQUENCY		Mode	Bandwidth [MHz]	Maximum Allowed Power [dBm]	Conducted Power [dBm]	Power Drift [dB]	MPR [dB]	Side	Test Position	Modulation	RB Size	RB Offset	Device Serial Number	Duty Cycle	SAR (1g)	Scaling Factor	Scaled SAR (1g)	Plot #	
MHz	Ch.														(W/kg)		(W/kg)		
1732.50	20175	Mid	LTE Band 4 (AWS)	20	23.0	23.00	-0.12	0	Right	Cheek	QPSK	1	99	F238A	1:1	0.078	1.000	0.078	
1732.50	20175	Mid	LTE Band 4 (AWS)	20	22.0	22.00	-0.09	1	Right	Cheek	QPSK	50	0	F238A	1:1	0.040	1.000	0.040	
1732.50	20175	Mid	LTE Band 4 (AWS)	20	23.0	23.00	-0.03	0	Right	Tilt	QPSK	1	99	F238A	1:1	0.048	1.000	0.048	
1732.50	20175	Mid	LTE Band 4 (AWS)	20	22.0	22.00	0.04	1	Right	Tilt	QPSK	50	0	F238A	1:1	0.029	1.000	0.029	
1732.50	20175	Mid	LTE Band 4 (AWS)	20	23.0	23.00	0.08	0	Left	Cheek	QPSK	1	99	F238A	1:1	0.085	1.000	0.085	A6
1732.50	20175	Mid	LTE Band 4 (AWS)	20	22.0	22.00	0.05	1	Left	Cheek	QPSK	50	0	F238A	1:1	0.058	1.000	0.058	
1732.50	20175	Mid	LTE Band 4 (AWS)	20	23.0	23.00	0.02	0	Left	Tilt	QPSK	1	99	F238A	1:1	0.048	1.000	0.048	
1732.50	20175	Mid	LTE Band 4 (AWS)	20	22.0	22.00	0.03	1	Left	Tilt	QPSK	50	0	F238A	1:1	0.036	1.000	0.036	
ANSI / IEEE C95.1 1992 - SAFETY LIMIT Spatial Peak Uncontrolled Exposure/General Population									Head 1.6 W/kg (mW/g) averaged over 1 gram										



FCC ID: A3LSMN915G		SAR EVALUATION REPORT		Reviewed by: Quality Manager
Document S/N: OY1408121709.A3L	Test Dates: 08/14/14 - 08/18/14	DUT Type: Portable Handset	Page 48 of 73	

**Table 11-7
LTE Band 2 (PCS) Head SAR**

MEASUREMENT RESULTS																			
FREQUENCY		Mode	Bandwidth [MHz]	Maximum Allowed Power [dBm]	Conducted Power [dBm]	Power Drift [dB]	MPR [dB]	Side	Test Position	Modulation	RB Size	RB Offset	Device Serial Number	Duty Cycle	SAR (1g)	Scaling Factor	Scaled SAR (1g)	Plot #	
MHz	Ch.														(W/kg)		(W/kg)		
1860.00	18700	Low	LTE Band 2 (PCS)	20	23.0	22.88	0.00	0	Right	Cheek	QPSK	1	0	F227C	1:1	0.197	1.028	0.203	A7
1860.00	18700	Low	LTE Band 2 (PCS)	20	22.0	21.88	-0.13	1	Right	Cheek	QPSK	50	0	F227C	1:1	0.150	1.028	0.154	
1860.00	18700	Low	LTE Band 2 (PCS)	20	23.0	22.88	-0.01	0	Right	Tilt	QPSK	1	0	F227C	1:1	0.153	1.028	0.157	
1860.00	18700	Low	LTE Band 2 (PCS)	20	22.0	21.88	0.00	1	Right	Tilt	QPSK	50	0	F227C	1:1	0.134	1.028	0.138	
1860.00	18700	Low	LTE Band 2 (PCS)	20	23.0	22.88	0.05	0	Left	Cheek	QPSK	1	0	F227C	1:1	0.081	1.028	0.083	
1860.00	18700	Low	LTE Band 2 (PCS)	20	22.0	21.88	0.08	1	Left	Cheek	QPSK	50	0	F227C	1:1	0.068	1.028	0.070	
1860.00	18700	Low	LTE Band 2 (PCS)	20	23.0	22.88	0.07	0	Left	Tilt	QPSK	1	0	F227C	1:1	0.042	1.028	0.043	
1860.00	18700	Low	LTE Band 2 (PCS)	20	22.0	21.88	0.09	1	Left	Tilt	QPSK	50	0	F227C	1:1	0.035	1.028	0.036	
ANSI / IEEE C95.1 1992 - SAFETY LIMIT Spatial Peak Uncontrolled Exposure/General Population										Head 1.6 W/kg (mW/g) averaged over 1 gram									



**Table 11-8
DTS Head SAR**

MEASUREMENT RESULTS																
FREQUENCY		Mode	Service	Maximum Allowed Power [dBm]	Conducted Power [dBm]	Power Drift [dB]	Side	Test Position	Antenna Config.	Device Serial Number	Data Rate (Mbps)	Duty Cycle	SAR (1g)	Scaling Factor	Scaled SAR (1g)	Plot #
MHz	Ch.												(W/kg)		(W/kg)	
2437	6	IEEE 802.11b	DSSS	17.5	17.20	0.21	Right	Cheek	1	F2279	1	1:1	0.061	1.072	0.065	
2437	6	IEEE 802.11b	DSSS	17.5	17.20	0.13	Right	Tilt	1	F2279	1	1:1	0.045	1.072	0.048	
2437	6	IEEE 802.11b	DSSS	17.5	17.20	0.12	Left	Cheek	1	F2279	1	1:1	0.019	1.072	0.020	
2437	6	IEEE 802.11b	DSSS	17.5	17.20	0.18	Left	Tilt	1	F2279	1	1:1	0.019	1.072	0.020	
2412	1	IEEE 802.11b	DSSS	17.5	17.33	0.06	Right	Cheek	2	F2279	1	1:1	0.197	1.040	0.205	A8
2412	1	IEEE 802.11b	DSSS	17.5	17.33	0.04	Right	Tilt	2	F2279	1	1:1	0.128	1.040	0.133	
2412	1	IEEE 802.11b	DSSS	17.5	17.33	0.14	Left	Cheek	2	F2279	1	1:1	0.128	1.040	0.133	
2412	1	IEEE 802.11b	DSSS	17.5	17.33	0.13	Left	Tilt	2	F2279	1	1:1	0.102	1.040	0.106	
2412	1	IEEE 802.11n	OFDM	16.5	16.18	0.13	Right	Cheek	MIMO	F2279	13	1:1	0.077	1.076	0.083	
2412	1	IEEE 802.11n	OFDM	16.5	16.18	0.15	Right	Tilt	MIMO	F2279	13	1:1	0.054	1.076	0.058	
2412	1	IEEE 802.11n	OFDM	16.5	16.18	0.14	Left	Cheek	MIMO	F2279	13	1:1	0.049	1.076	0.053	
2412	1	IEEE 802.11n	OFDM	16.5	16.18	0.18	Left	Tilt	MIMO	F2279	13	1:1	0.038	1.076	0.041	
5745	149	IEEE 802.11a	OFDM	14.5	13.58	0.13	Right	Cheek	1	F238A	6	1:1	0.034	1.236	0.042	
5775	155	IEEE 802.11ac	OFDM	11.5	10.76	0.20	Right	Cheek	1	F238A	29.3	1:1	0.009	1.186	0.011	
5745	149	IEEE 802.11a	OFDM	14.5	13.58	-0.20	Right	Tilt	1	F238A	6	1:1	0.000	1.236	0.000	
5745	149	IEEE 802.11a	OFDM	14.5	13.58	0.00	Left	Cheek	1	F238A	6	1:1	0.004	1.236	0.005	
5745	149	IEEE 802.11a	OFDM	14.5	13.58	-0.20	Left	Tilt	1	F238A	6	1:1	0.000	1.236	0.000	
5825	165	IEEE 802.11a	OFDM	14.5	14.22	0.17	Right	Cheek	2	F238A	6	1:1	0.083	1.067	0.089	A9
5775	155	IEEE 802.11ac	OFDM	11.5	11.19	0.20	Right	Cheek	2	F238A	29.3	1:1	0.025	1.074	0.027	
5825	165	IEEE 802.11a	OFDM	14.5	14.22	0.15	Right	Tilt	2	F238A	6	1:1	0.067	1.067	0.071	
5825	165	IEEE 802.11a	OFDM	14.5	14.22	0.15	Left	Cheek	2	F238A	6	1:1	0.053	1.067	0.057	
5825	165	IEEE 802.11a	OFDM	14.5	14.22	-0.15	Left	Tilt	2	F238A	6	1:1	0.048	1.067	0.051	
5765	153	IEEE 802.11n	OFDM	13.5	13.01	0.00	Right	Cheek	MIMO	F238A	13	1:1	0.006	1.119	0.007	
5765	153	IEEE 802.11n	OFDM	13.5	13.01	0.20	Right	Tilt	MIMO	F238A	13	1:1	0.001	1.119	0.001	
5765	153	IEEE 802.11n	OFDM	13.5	13.01	0.20	Left	Cheek	MIMO	F238A	13	1:1	0.002	1.119	0.002	
5765	153	IEEE 802.11n	OFDM	13.5	13.01	0.20	Left	Tilt	MIMO	F238A	13	1:1	0.003	1.119	0.003	
ANSI / IEEE C95.1 1992 - SAFETY LIMIT Spatial Peak Uncontrolled Exposure/General Population										Head 1.6 W/kg (mW/g) averaged over 1 gram						

FCC ID: A3LSMN915G		SAR EVALUATION REPORT		Reviewed by: Quality Manager
Document S/N: OY1408121709.A3L	Test Dates: 08/14/14 - 08/18/14	DUT Type: Portable Handset	Page 49 of 73	

**Table 11-9
NII Head SAR**

MEASUREMENT RESULTS																
FREQUENCY		Mode	Service	Maximum Allowed Power [dBm]	Conducted Power [dBm]	Power Drift [dB]	Side	Test Position	Antenna Config.	Device Serial Number	Data Rate (Mbps)	Duty Cycle	SAR (1g)	Scaling Factor	Scaled SAR (1g)	Plot #
MHz	Ch.												(W/kg)		(W/kg)	
5180	36	IEEE 802.11a	OFDM	14.5	13.63	0.12	Right	Cheek	1	F238A	6	1:1	0.071	1.222	0.087	
5210	42	IEEE 802.11ac	OFDM	11.5	11.05	0.11	Right	Cheek	1	F238A	29.3	1:1	0.012	1.109	0.013	
5180	36	IEEE 802.11a	OFDM	14.5	13.63	-0.15	Right	Tilt	1	F238A	6	1:1	0.012	1.222	0.015	
5180	36	IEEE 802.11a	OFDM	14.5	13.63	0.17	Left	Cheek	1	F238A	6	1:1	0.020	1.222	0.024	
5180	36	IEEE 802.11a	OFDM	14.5	13.63	0.00	Left	Tilt	1	F238A	6	1:1	0.001	1.222	0.001	
5260	52	IEEE 802.11a	OFDM	14.5	13.98	0.08	Right	Cheek	1	F238A	6	1:1	0.057	1.127	0.064	
5290	58	IEEE 802.11ac	OFDM	11.5	10.56	-0.20	Right	Cheek	1	F238A	29.3	1:1	0.009	1.242	0.011	
5260	52	IEEE 802.11a	OFDM	14.5	13.98	0.14	Right	Tilt	1	F238A	6	1:1	0.012	1.127	0.014	
5260	52	IEEE 802.11a	OFDM	14.5	13.98	0.12	Left	Cheek	1	F238A	6	1:1	0.018	1.127	0.020	
5260	52	IEEE 802.11a	OFDM	14.5	13.98	0.13	Left	Tilt	1	F238A	6	1:1	0.000	1.127	0.000	
5500	100	IEEE 802.11a	OFDM	14.5	13.65	0.18	Right	Cheek	1	F238A	6	1:1	0.021	1.216	0.026	
5530	106	IEEE 802.11ac	OFDM	11.5	10.90	0.00	Right	Cheek	1	F238A	29.3	1:1	0.009	1.148	0.010	
5500	100	IEEE 802.11a	OFDM	14.5	13.65	0.20	Right	Tilt	1	F238A	6	1:1	0.000	1.216	0.000	
5500	100	IEEE 802.11a	OFDM	14.5	13.65	0.20	Left	Cheek	1	F238A	6	1:1	0.004	1.216	0.005	
5500	100	IEEE 802.11a	OFDM	14.5	13.65	0.00	Left	Tilt	1	F238A	6	1:1	0.000	1.216	0.000	
5180	36	IEEE 802.11a	OFDM	14.5	14.14	0.13	Right	Cheek	2	F238A	6	1:1	0.072	1.086	0.078	
5180	36	IEEE 802.11a	OFDM	14.5	14.14	0.18	Right	Tilt	2	F238A	6	1:1	0.059	1.086	0.064	
5180	36	IEEE 802.11a	OFDM	14.5	14.14	0.16	Left	Cheek	2	F238A	6	1:1	0.083	1.086	0.090	
5210	42	IEEE 802.11ac	OFDM	11.5	11.11	0.15	Left	Cheek	2	F238A	29.3	1:1	0.023	1.094	0.025	
5180	36	IEEE 802.11a	OFDM	14.5	14.14	0.17	Left	Tilt	2	F238A	6	1:1	0.069	1.086	0.075	
5260	52	IEEE 802.11a	OFDM	14.5	13.70	0.21	Right	Cheek	2	F238A	6	1:1	0.076	1.202	0.091	
5290	58	IEEE 802.11ac	OFDM	11.5	10.70	0.16	Right	Cheek	2	F238A	29.3	1:1	0.027	1.202	0.032	
5260	52	IEEE 802.11a	OFDM	14.5	13.70	0.14	Right	Tilt	2	F238A	6	1:1	0.068	1.202	0.082	
5260	52	IEEE 802.11a	OFDM	14.5	13.70	0.19	Left	Cheek	2	F238A	6	1:1	0.070	1.202	0.084	
5260	52	IEEE 802.11a	OFDM	14.5	13.70	0.12	Left	Tilt	2	F238A	6	1:1	0.072	1.202	0.087	
5700	140	IEEE 802.11a	OFDM	14.5	14.21	0.11	Right	Cheek	2	F238A	6	1:1	0.098	1.069	0.105	A10
5530	106	IEEE 802.11ac	OFDM	11.5	10.73	0.12	Right	Cheek	2	F238A	29.3	1:1	0.029	1.194	0.035	
5700	140	IEEE 802.11a	OFDM	14.5	14.21	0.19	Right	Tilt	2	F238A	6	1:1	0.078	1.069	0.083	
5700	140	IEEE 802.11a	OFDM	14.5	14.21	0.14	Left	Cheek	2	F238A	6	1:1	0.075	1.069	0.080	
5700	140	IEEE 802.11a	OFDM	14.5	14.21	0.15	Left	Tilt	2	F238A	6	1:1	0.060	1.069	0.064	
5200	40	IEEE 802.11n	OFDM	13.5	12.59	0.16	Right	Cheek	MIMO	F238A	13	1:1	0.011	1.233	0.014	
5200	40	IEEE 802.11n	OFDM	13.5	12.59	-0.16	Right	Tilt	MIMO	F238A	13	1:1	0.008	1.233	0.010	
5200	40	IEEE 802.11n	OFDM	13.5	12.59	0.14	Left	Cheek	MIMO	F238A	13	1:1	0.013	1.233	0.016	
5200	40	IEEE 802.11n	OFDM	13.5	12.59	0.18	Left	Tilt	MIMO	F238A	13	1:1	0.013	1.233	0.016	
5320	64	IEEE 802.11n	OFDM	13.5	12.44	0.19	Right	Cheek	MIMO	F238A	13	1:1	0.012	1.276	0.015	
5320	64	IEEE 802.11n	OFDM	13.5	12.44	-0.16	Right	Tilt	MIMO	F238A	13	1:1	0.014	1.276	0.018	
5320	64	IEEE 802.11n	OFDM	13.5	12.44	0.19	Left	Cheek	MIMO	F238A	13	1:1	0.014	1.276	0.018	
5320	64	IEEE 802.11n	OFDM	13.5	12.44	0.02	Left	Tilt	MIMO	F238A	13	1:1	0.012	1.276	0.015	
5500	100	IEEE 802.11n	OFDM	13.5	12.63	0.20	Right	Cheek	MIMO	F238A	13	1:1	0.010	1.222	0.012	
5500	100	IEEE 802.11n	OFDM	13.5	12.63	0.10	Right	Tilt	MIMO	F238A	13	1:1	0.014	1.222	0.017	
5500	100	IEEE 802.11n	OFDM	13.5	12.63	0.12	Left	Cheek	MIMO	F238A	13	1:1	0.011	1.222	0.013	
5500	100	IEEE 802.11n	OFDM	13.5	12.63	-0.16	Left	Tilt	MIMO	F238A	13	1:1	0.009	1.222	0.011	
ANSI / IEEE C95.1 1992 - SAFETY LIMIT Spatial Peak Uncontrolled Exposure/General Population								Head 1.6 W/kg (mW/g) averaged over 1 gram								

FCC ID: A3LSMN915G		SAR EVALUATION REPORT		Reviewed by: Quality Manager
Document S/N: OY1408121709.A3L	Test Dates: 08/14/14 - 08/18/14	DUT Type: Portable Handset	Page 50 of 73	

11.2 Standalone Body-Worn SAR Data

**Table 11-10
GSM/UMTS Body-Worn SAR Data**



MEASUREMENT RESULTS															
FREQUENCY		Mode	Service	Maximum Allowed Power [dBm]	Conducted Power [dBm]	Power Drift [dB]	Spacing	Device Serial Number	# of Time Slots	Duty Cycle	Side	SAR (1g) (W/kg)	Scaling Factor	Scaled SAR (1g) (W/kg)	Plot #
MHz	Ch.														
836.60	190	GSM 850	GSM	33.5	32.80	0.02	10 mm	F238A	1	1:8.3	back	0.237	1.175	0.278	A11
1880.00	661	GSM 1900	GSM	30.0	29.54	0.11	10 mm	F238A	1	1:8.3	back	0.189	1.112	0.210	A13
836.60	4183	UMTS 850	RMC	24.0	23.40	0.07	10 mm	F227C	N/A	1:1	back	0.324	1.148	0.372	A15
1880.00	9400	UMTS 1900	RMC	23.0	22.70	0.02	10 mm	F227C	N/A	1:1	back	0.273	1.072	0.293	A17
ANSI / IEEE C95.1 1992 - SAFETY LIMIT Spatial Peak Uncontrolled Exposure/General Population							Body 1.6 W/kg (mW/g) averaged over 1 gram								

**Table 11-11
LTE Body-Worn SAR**

MEASUREMENT RESULTS																			
FREQUENCY		Mode	Bandwidth [MHz]	Maximum Allowed Power [dBm]	Conducted Power [dBm]	Power Drift [dB]	MPR [dB]	Device Serial Number	Modulation	RB Size	RB Offset	Spacing	Side	Duty Cycle	SAR (1g) (W/kg)	Scaling Factor	Scaled SAR (1g) (W/kg)	Plot #	
MHz	Ch.																		
836.50	20525	Mid	LTE Band 5 (Cell)	10	23.5	22.70	0.05	0	F238A	QPSK	1	0	10 mm	back	1:1	0.252	1.202	0.303	A19
836.50	20525	Mid	LTE Band 5 (Cell)	10	22.5	21.69	-0.05	1	F238A	QPSK	25	0	10 mm	back	1:1	0.236	1.205	0.284	
1732.50	20175	Mid	LTE Band 4 (AWS)	20	23.0	23.00	0.18	0	F238A	QPSK	1	99	10 mm	back	1:1	0.276	1.000	0.276	A21
1732.50	20175	Mid	LTE Band 4 (AWS)	20	22.0	22.00	0.19	1	F238A	QPSK	50	0	10 mm	back	1:1	0.196	1.000	0.196	
1860.00	18700	Low	LTE Band 2 (PCS)	20	23.0	22.88	-0.06	0	F227C	QPSK	1	0	10 mm	back	1:1	0.224	1.028	0.230	A23
1860.00	18700	Low	LTE Band 2 (PCS)	20	22.0	21.88	0.08	1	F227C	QPSK	50	0	10 mm	back	1:1	0.189	1.028	0.194	
ANSI / IEEE C95.1 1992 - SAFETY LIMIT Spatial Peak Uncontrolled Exposure/General Population							Body 1.6 W/kg (mW/g) averaged over 1 gram												

**Table 11-12
DTS Body-Worn SAR**

MEASUREMENT RESULTS																
FREQUENCY		Mode	Service	Maximum Allowed Power [dBm]	Conducted Power [dBm]	Power Drift [dB]	Spacing	Antenna Config.	Device Serial Number	Data Rate (Mbps)	Side	Duty Cycle	SAR (1g) (W/kg)	Scaling Factor	Scaled SAR (1g) (W/kg)	Plot #
MHz	Ch.															
2437	6	IEEE 802.11b	DSSS	17.5	17.20	0.04	10 mm	1	F2279	1	back	1:1	0.069	1.072	0.074	A25
2412	1	IEEE 802.11b	DSSS	17.5	17.33	0.05	10 mm	2	F2279	1	back	1:1	0.052	1.040	0.054	
2412	1	IEEE 802.11n	OFDM	16.5	16.18	0.13	10 mm	MIMO	F2279	13	back	1:1	0.025	1.076	0.027	
5745	149	IEEE 802.11a	OFDM	14.5	13.58	0.14	10 mm	1	F227C	6	back	1:1	0.153	1.236	0.189	A26
5775	155	IEEE 802.11ac	OFDM	11.5	10.76	0.19	10 mm	1	F227C	29.3	back	1:1	0.042	1.186	0.050	
5825	165	IEEE 802.11a	OFDM	14.5	14.22	0.18	10 mm	2	F227C	6	back	1:1	0.137	1.067	0.146	
5775	155	IEEE 802.11ac	OFDM	11.5	11.19	0.18	10 mm	2	F227C	29.3	back	1:1	0.072	1.074	0.077	
5765	153	IEEE 802.11n	OFDM	13.5	13.01	0.12	10 mm	MIMO	F227C	13	back	1:1	0.023	1.119	0.026	
ANSI / IEEE C95.1 1992 - SAFETY LIMIT Spatial Peak Uncontrolled Exposure/General Population							Body 1.6 W/kg (mW/g) averaged over 1 gram									

FCC ID: A3LSMN915G		SAR EVALUATION REPORT		Reviewed by: Quality Manager
Document S/N: OY1408121709.A3L	Test Dates: 08/14/14 - 08/18/14	DUT Type: Portable Handset		Page 51 of 73

**Table 11-13
NII Body-Worn SAR**

MEASUREMENT RESULTS																
FREQUENCY		Mode	Service	Maximum Allowed Power [dBm]	Conducted Power [dBm]	Power Drift [dB]	Spacing	Antenna Config.	Device Serial Number	Data Rate (Mbps)	Side	Duty Cycle	SAR (1g)	Scaling Factor	Scaled SAR (1g)	Plot #
MHz	Ch.												(W/kg)		(W/kg)	
5180	36	IEEE 802.11a	OFDM	14.5	13.63	0.10	10 mm	1	F227C	6	back	1:1	0.231	1.222	0.282	
5210	42	IEEE 802.11ac	OFDM	11.5	11.05	0.15	10 mm	1	F227C	29.3	back	1:1	0.073	1.109	0.081	
5260	52	IEEE 802.11a	OFDM	14.5	13.98	0.15	10 mm	1	F227C	6	back	1:1	0.159	1.127	0.179	
5290	58	IEEE 802.11ac	OFDM	11.5	10.56	-0.02	10 mm	1	F227C	29.3	back	1:1	0.069	1.242	0.086	
5500	100	IEEE 802.11a	OFDM	14.5	13.65	0.17	10 mm	1	F227C	6	back	1:1	0.154	1.216	0.187	
5530	106	IEEE 802.11ac	OFDM	11.5	10.90	0.14	10 mm	1	F227C	29.3	back	1:1	0.045	1.148	0.052	
5180	36	IEEE 802.11a	OFDM	14.5	14.14	0.15	10 mm	2	F227C	6	back	1:1	0.359	1.086	0.390	
5210	42	IEEE 802.11ac	OFDM	11.5	11.11	0.14	10 mm	2	F227C	29.3	back	1:1	0.144	1.094	0.158	
5260	52	IEEE 802.11a	OFDM	14.5	13.70	0.16	10 mm	2	F227C	6	back	1:1	0.333	1.202	0.400	
5290	58	IEEE 802.11ac	OFDM	11.5	10.70	0.04	10 mm	2	F227C	29.3	back	1:1	0.145	1.202	0.174	
5700	140	IEEE 802.11a	OFDM	14.5	14.21	-0.18	10 mm	2	F227C	6	back	1:1	0.403	1.069	0.431	A27
5530	106	IEEE 802.11ac	OFDM	11.5	10.73	-0.15	10 mm	2	F227C	29.3	back	1:1	0.105	1.194	0.125	
5200	40	IEEE 802.11n	OFDM	13.5	12.59	0.14	10 mm	MMO	F227C	13	back	1:1	0.128	1.233	0.158	
5320	64	IEEE 802.11n	OFDM	13.5	12.44	-0.17	10 mm	MMO	F227C	13	back	1:1	0.063	1.276	0.080	
5500	100	IEEE 802.11n	OFDM	13.5	12.63	-0.21	10 mm	MMO	F227C	13	back	1:1	0.046	1.222	0.056	
ANSI / IEEE C95.1 1992 - SAFETY LIMIT Spatial Peak Uncontrolled Exposure/General Population							Body 1.6 W/kg (mW/g) averaged over 1 gram									

11.3 Standalone Wireless Router SAR Data

**Table 11-14
GPRS/UMTS/ Hotspot SAR Data**

MEASUREMENT RESULTS															
FREQUENCY		Mode	Service	Maximum Allowed Power [dBm]	Conducted Power [dBm]	Power Drift [dB]	Spacing	Device Serial Number	# of GPRS Slots	Duty Cycle	Side	SAR (1g)	Scaling Factor	Scaled SAR (1g)	Plot #
MHz	Ch.											(W/kg)		(W/kg)	
836.60	190	GSM 850	GPRS	28.5	27.35	-0.10	10 mm	F238A	4	1:2.076	back	0.233	1.303	0.304	
836.60	190	GSM 850	GPRS	28.5	27.35	0.05	10 mm	F238A	4	1:2.076	front	0.256	1.303	0.334	A12
836.60	190	GSM 850	GPRS	28.5	27.35	-0.07	10 mm	F238A	4	1:2.076	bottom	0.184	1.303	0.240	
836.60	190	GSM 850	GPRS	28.5	27.35	0.04	10 mm	F238A	4	1:2.076	right	0.167	1.303	0.218	
836.60	190	GSM 850	GPRS	28.5	27.35	0.03	10 mm	F238A	4	1:2.076	left	0.062	1.303	0.081	
1880.00	661	GSM 1900	GPRS	27.0	26.54	0.01	10 mm	F238A	3	1:2.76	back	0.190	1.112	0.211	
1880.00	661	GSM 1900	GPRS	27.0	26.54	0.09	10 mm	F238A	3	1:2.76	front	0.325	1.112	0.361	
1880.00	661	GSM 1900	GPRS	27.0	26.54	-0.06	10 mm	F238A	3	1:2.76	bottom	0.529	1.112	0.588	A14
1880.00	661	GSM 1900	GPRS	27.0	26.54	0.08	10 mm	F238A	3	1:2.76	right	0.030	1.112	0.033	
1880.00	661	GSM 1900	GPRS	27.0	26.54	-0.03	10 mm	F238A	3	1:2.76	left	0.212	1.112	0.236	
836.60	4183	UMTS 850	RMC	24.0	23.40	0.07	10 mm	F227C	N/A	1:1	back	0.324	1.148	0.372	
836.60	4183	UMTS 850	RMC	24.0	23.40	0.03	10 mm	F227C	N/A	1:1	front	0.367	1.148	0.421	A16
836.60	4183	UMTS 850	RMC	24.0	23.40	-0.20	10 mm	F227C	N/A	1:1	bottom	0.214	1.148	0.246	
836.60	4183	UMTS 850	RMC	24.0	23.40	0.03	10 mm	F227C	N/A	1:1	right	0.208	1.148	0.239	
836.60	4183	UMTS 850	RMC	24.0	23.40	0.00	10 mm	F227C	N/A	1:1	left	0.101	1.148	0.116	
1880.00	9400	UMTS 1900	RMC	23.0	22.70	0.02	10 mm	F227C	N/A	1:1	back	0.273	1.072	0.293	
1880.00	9400	UMTS 1900	RMC	23.0	22.70	0.02	10 mm	F227C	N/A	1:1	front	0.341	1.072	0.366	
1880.00	9400	UMTS 1900	RMC	23.0	22.70	-0.04	10 mm	F227C	N/A	1:1	bottom	0.523	1.072	0.561	A18
1880.00	9400	UMTS 1900	RMC	23.0	22.70	0.07	10 mm	F227C	N/A	1:1	right	0.050	1.072	0.054	
1880.00	9400	UMTS 1900	RMC	23.0	22.70	0.09	10 mm	F227C	N/A	1:1	left	0.214	1.072	0.229	
ANSI / IEEE C95.1 1992 - SAFETY LIMIT Spatial Peak Uncontrolled Exposure/General Population							Body 1.6 W/kg (mW/g) averaged over 1 gram								

FCC ID: A3LSMN915G		SAR EVALUATION REPORT		Reviewed by: Quality Manager
Document S/N: OY1408121709.A3L	Test Dates: 08/14/14 - 08/18/14	DUT Type: Portable Handset		Page 52 of 73

**Table 11-15
LTE Band 5 (Cell) Hotspot SAR**



MEASUREMENT RESULTS																			
FREQUENCY		Mode	Bandwidth [MHz]	Maximum Allowed Power [dBm]	Conducted Power [dBm]	Power Drift [dB]	MPR [dB]	Device Serial Number	Modulation	RB Size	RB Offset	Spacing	Side	Duty Cycle	SAR (1g) (W/kg)	Scaling Factor	Scaled SAR (1g) (W/kg)	Plot #	
MHz	Ch.																		
836.50	20525	Mid	LTE Band 5 (Cell)	10	23.5	22.70	0.05	0	F238A	QPSK	1	0	10 mm	back	1:1	0.252	1.202	0.303	
836.50	20525	Mid	LTE Band 5 (Cell)	10	22.5	21.69	-0.05	1	F238A	QPSK	25	0	10 mm	back	1:1	0.236	1.205	0.284	
836.50	20525	Mid	LTE Band 5 (Cell)	10	23.5	22.70	-0.01	0	F238A	QPSK	1	0	10 mm	front	1:1	0.320	1.202	0.385	A20
836.50	20525	Mid	LTE Band 5 (Cell)	10	22.5	21.69	-0.03	1	F238A	QPSK	25	0	10 mm	front	1:1	0.303	1.205	0.365	
836.50	20525	Mid	LTE Band 5 (Cell)	10	23.5	22.70	-0.03	0	F238A	QPSK	1	0	10 mm	bottom	1:1	0.185	1.202	0.222	
836.50	20525	Mid	LTE Band 5 (Cell)	10	22.5	21.69	-0.01	1	F238A	QPSK	25	0	10 mm	bottom	1:1	0.180	1.205	0.217	
836.50	20525	Mid	LTE Band 5 (Cell)	10	23.5	22.70	0.02	0	F238A	QPSK	1	0	10 mm	right	1:1	0.158	1.202	0.190	
836.50	20525	Mid	LTE Band 5 (Cell)	10	22.5	21.69	0.02	1	F238A	QPSK	25	0	10 mm	right	1:1	0.149	1.205	0.180	
836.50	20525	Mid	LTE Band 5 (Cell)	10	23.5	22.70	0.09	0	F238A	QPSK	1	0	10 mm	left	1:1	0.060	1.202	0.072	
836.50	20525	Mid	LTE Band 5 (Cell)	10	22.5	21.69	-0.06	1	F238A	QPSK	25	0	10 mm	left	1:1	0.048	1.205	0.058	
ANSI / IEEE C95.1 1992 - SAFETY LIMIT Spatial Peak Uncontrolled Exposure/General Population								Body 1.6 W/kg (mW/g) averaged over 1 gram											

**Table 11-16
LTE Band 4 (AWS) Hotspot SAR**

MEASUREMENT RESULTS																			
FREQUENCY		Mode	Bandwidth [MHz]	Maximum Allowed Power [dBm]	Conducted Power [dBm]	Power Drift [dB]	MPR [dB]	Device Serial Number	Modulation	RB Size	RB Offset	Spacing	Side	Duty Cycle	SAR (1g) (W/kg)	Scaling Factor	Scaled SAR (1g) (W/kg)	Plot #	
MHz	Ch.																		
1732.50	20175	Mid	LTE Band 4 (AWS)	20	23.0	23.00	0.18	0	F238A	QPSK	1	99	10 mm	back	1:1	0.276	1.000	0.276	
1732.50	20175	Mid	LTE Band 4 (AWS)	20	22.0	22.00	0.19	1	F238A	QPSK	50	0	10 mm	back	1:1	0.196	1.000	0.196	
1732.50	20175	Mid	LTE Band 4 (AWS)	20	23.0	23.00	0.02	0	F238A	QPSK	1	99	10 mm	front	1:1	0.418	1.000	0.418	
1732.50	20175	Mid	LTE Band 4 (AWS)	20	22.0	22.00	-0.08	1	F238A	QPSK	50	0	10 mm	front	1:1	0.288	1.000	0.288	
1732.50	20175	Mid	LTE Band 4 (AWS)	20	23.0	23.00	0.18	0	F238A	QPSK	1	99	10 mm	bottom	1:1	0.471	1.000	0.471	A22
1732.50	20175	Mid	LTE Band 4 (AWS)	20	22.0	22.00	-0.03	1	F238A	QPSK	50	0	10 mm	bottom	1:1	0.305	1.000	0.305	
1732.50	20175	Mid	LTE Band 4 (AWS)	20	23.0	23.00	0.15	0	F238A	QPSK	1	99	10 mm	right	1:1	0.036	1.000	0.036	
1732.50	20175	Mid	LTE Band 4 (AWS)	20	22.0	22.00	0.18	1	F238A	QPSK	50	0	10 mm	right	1:1	0.019	1.000	0.019	
1732.50	20175	Mid	LTE Band 4 (AWS)	20	23.0	23.00	-0.06	0	F238A	QPSK	1	99	10 mm	left	1:1	0.307	1.000	0.307	
1732.50	20175	Mid	LTE Band 4 (AWS)	20	22.0	22.00	0.08	1	F238A	QPSK	50	0	10 mm	left	1:1	0.206	1.000	0.206	
ANSI / IEEE C95.1 1992 - SAFETY LIMIT Spatial Peak Uncontrolled Exposure/General Population								Body 1.6 W/kg (mW/g) averaged over 1 gram											



**Table 11-17
LTE Band 2 (PCS) Hotspot SAR**

MEASUREMENT RESULTS																			
FREQUENCY		Mode	Bandwidth [MHz]	Maximum Allowed Power [dBm]	Conducted Power [dBm]	Power Drift [dB]	MPR [dB]	Device Serial Number	Modulation	RB Size	RB Offset	Spacing	Side	Duty Cycle	SAR (1g) (W/kg)	Scaling Factor	Scaled SAR (1g) (W/kg)	Plot #	
MHz	Ch.																		
1860.00	18700	Low	LTE Band 2 (PCS)	20	23.0	22.88	-0.06	0	F227C	QPSK	1	0	10 mm	back	1:1	0.224	1.028	0.230	
1860.00	18700	Low	LTE Band 2 (PCS)	20	22.0	21.88	0.08	1	F227C	QPSK	50	0	10 mm	back	1:1	0.189	1.028	0.194	
1860.00	18700	Low	LTE Band 2 (PCS)	20	23.0	22.88	-0.02	0	F227C	QPSK	1	0	10 mm	front	1:1	0.344	1.028	0.354	
1860.00	18700	Low	LTE Band 2 (PCS)	20	22.0	21.88	0.06	1	F227C	QPSK	50	0	10 mm	front	1:1	0.285	1.028	0.293	
1860.00	18700	Low	LTE Band 2 (PCS)	20	23.0	22.88	0.02	0	F227C	QPSK	1	0	10 mm	bottom	1:1	0.642	1.028	0.660	A24
1860.00	18700	Low	LTE Band 2 (PCS)	20	22.0	21.88	0.07	1	F227C	QPSK	50	0	10 mm	bottom	1:1	0.512	1.028	0.526	
1860.00	18700	Low	LTE Band 2 (PCS)	20	23.0	22.88	0.19	0	F227C	QPSK	1	0	10 mm	right	1:1	0.061	1.028	0.063	
1860.00	18700	Low	LTE Band 2 (PCS)	20	22.0	21.88	-0.15	1	F227C	QPSK	50	0	10 mm	right	1:1	0.051	1.028	0.052	
1860.00	18700	Low	LTE Band 2 (PCS)	20	23.0	22.88	0.03	0	F227C	QPSK	1	0	10 mm	left	1:1	0.229	1.028	0.235	
1860.00	18700	Low	LTE Band 2 (PCS)	20	22.0	21.88	-0.16	1	F227C	QPSK	50	0	10 mm	left	1:1	0.193	1.028	0.198	
ANSI / IEEE C95.1 1992 - SAFETY LIMIT Spatial Peak Uncontrolled Exposure/General Population								Body 1.6 W/kg (mW/g) averaged over 1 gram											

FCC ID: A3LSMN915G	 PCTEST <small>PRODUCING UNPRECEDENTED</small>	SAR EVALUATION REPORT		Reviewed by: Quality Manager
Document S/N: OY1408121709.A3L	Test Dates: 08/14/14 - 08/18/14	DUT Type: Portable Handset		Page 53 of 73

**Table 11-18
WLAN Hotspot SAR**

MEASUREMENT RESULTS																
FREQUENCY		Mode	Service	Maximum Allowed Power [dBm]	Conducted Power [dBm]	Power Drift [dB]	Spacing	Antenna Config.	Device Serial Number	Data Rate (Mbps)	Side	Duty Cycle	SAR (1g)	Scaling Factor	Scaled SAR (1g)	Plot #
MHz	Ch.												(W/kg)		(W/kg)	
2437	6	IEEE 802.11b	DSSS	17.5	17.20	0.04	10 mm	1	F2279	1	back	1:1	0.069	1.072	0.074	A25
2437	6	IEEE 802.11b	DSSS	17.5	17.20	0.12	10 mm	1	F2279	1	front	1:1	0.012	1.072	0.013	
2437	6	IEEE 802.11b	DSSS	17.5	17.20	0.19	10 mm	1	F2279	1	top	1:1	0.007	1.072	0.008	
2437	6	IEEE 802.11b	DSSS	17.5	17.20	0.15	10 mm	1	F2279	1	left	1:1	0.019	1.072	0.020	
2412	1	IEEE 802.11b	DSSS	17.5	17.33	0.05	10 mm	2	F2279	1	back	1:1	0.052	1.040	0.054	
2412	1	IEEE 802.11b	DSSS	17.5	17.33	-0.21	10 mm	2	F2279	1	front	1:1	0.034	1.040	0.035	
2412	1	IEEE 802.11b	DSSS	17.5	17.33	0.21	10 mm	2	F2279	1	top	1:1	0.005	1.040	0.005	
2412	1	IEEE 802.11n	OFDM	16.5	16.18	0.13	10 mm	MIMO	F2279	13	back	1:1	0.025	1.076	0.027	
2412	1	IEEE 802.11n	OFDM	16.5	16.18	0.13	10 mm	MIMO	F2279	13	front	1:1	0.013	1.076	0.014	
2412	1	IEEE 802.11n	OFDM	16.5	16.18	0.19	10 mm	MIMO	F2279	13	top	1:1	0.003	1.076	0.003	
2412	1	IEEE 802.11n	OFDM	16.5	16.18	0.20	10 mm	MIMO	F2279	13	left	1:1	0.004	1.076	0.004	
ANSI / IEEE C95.1 1992 - SAFETY LIMIT Spatial Peak Uncontrolled Exposure/General Population							Body 1.6 W/kg (mW/g) averaged over 1 gram									

FCC ID: A3LSMN915G	 PCTEST ENGINEERING LABORATORY, INC.	SAR EVALUATION REPORT		Reviewed by: Quality Manager
Document S/N: OY1408121709.A3L	Test Dates: 08/14/14 - 08/18/14	DUT Type: Portable Handset	Page 54 of 73	



11.4 Standalone Hand SAR Data

**Table 11-19
WLAN Hand SAR**

MEASUREMENT RESULTS																
FREQUENCY		Mode	Service	Maximum Allowed Power [dBm]	Conducted Power [dBm]	Power Drift [dB]	Spacing	Antenna Config.	Device Serial Number	Data Rate (Mbps)	Side	Duty Cycle	SAR (10g) (W/kg)	Scaling Factor	Scaled SAR (10g) (W/kg)	Plot #
Mhz	Ch.															
5745	149	IEEE 802.11a	OFDM	14.5	13.58	0.12	0 mm	1	F227C	6	back	1:1	0.259	1.236	0.320	A28
5775	155	IEEE 802.11ac	OFDM	11.5	10.76	0.12	0 mm	1	F227C	29.3	back	1:1	0.105	1.186	0.125	
5745	149	IEEE 802.11a	OFDM	14.5	13.58	0.12	0 mm	1	F227C	6	front	1:1	0.062	1.236	0.077	
5745	149	IEEE 802.11a	OFDM	14.5	13.58	0.16	0 mm	1	F227C	6	top	1:1	0.017	1.236	0.021	
5745	149	IEEE 802.11a	OFDM	14.5	13.58	0.18	0 mm	1	F227C	6	left	1:1	0.057	1.236	0.070	
5180	36	IEEE 802.11a	OFDM	14.5	13.63	-0.04	0 mm	1	F227C	6	back	1:1	0.451	1.222	0.551	
5210	42	IEEE 802.11ac	OFDM	11.5	11.05	0.09	0 mm	1	F227C	29.3	back	1:1	0.167	1.109	0.185	
5180	36	IEEE 802.11a	OFDM	14.5	13.63	0.14	0 mm	1	F227C	6	front	1:1	0.119	1.222	0.145	
5180	36	IEEE 802.11a	OFDM	14.5	13.63	0.09	0 mm	1	F227C	6	top	1:1	0.026	1.222	0.032	
5180	36	IEEE 802.11a	OFDM	14.5	13.63	-0.20	0 mm	1	F227C	6	left	1:1	0.174	1.222	0.213	
5260	52	IEEE 802.11a	OFDM	14.5	13.98	-0.05	0 mm	1	F227C	6	back	1:1	0.540	1.127	0.609	
5290	58	IEEE 802.11ac	OFDM	11.5	10.56	0.08	0 mm	1	F227C	29.3	back	1:1	0.168	1.242	0.210	
5260	52	IEEE 802.11a	OFDM	14.5	13.98	0.14	0 mm	1	F227C	6	front	1:1	0.052	1.127	0.059	
5260	52	IEEE 802.11a	OFDM	14.5	13.98	0.19	0 mm	1	F227C	6	top	1:1	0.021	1.127	0.024	
5260	52	IEEE 802.11a	OFDM	14.5	13.98	-0.16	0 mm	1	F227C	6	left	1:1	0.123	1.127	0.139	
5500	100	IEEE 802.11a	OFDM	14.5	13.65	0.09	0 mm	1	F227C	6	back	1:1	0.355	1.216	0.432	
5530	106	IEEE 802.11ac	OFDM	11.5	10.90	0.15	0 mm	1	F227C	29.3	back	1:1	0.139	1.148	0.160	
5500	100	IEEE 802.11a	OFDM	14.5	13.65	0.13	0 mm	1	F227C	6	front	1:1	0.038	1.216	0.046	
5500	100	IEEE 802.11a	OFDM	14.5	13.65	0.18	0 mm	1	F227C	6	top	1:1	0.016	1.216	0.019	
5500	100	IEEE 802.11a	OFDM	14.5	13.65	-0.16	0 mm	1	F227C	6	left	1:1	0.066	1.216	0.080	
5825	165	IEEE 802.11a	OFDM	14.5	14.22	0.08	0 mm	2	F227C	6	back	1:1	0.180	1.067	0.192	
5775	155	IEEE 802.11ac	OFDM	11.5	11.19	-0.21	0 mm	2	F227C	29.3	back	1:1	0.103	1.074	0.111	
5825	165	IEEE 802.11a	OFDM	14.5	14.22	-0.17	0 mm	2	F227C	6	front	1:1	0.134	1.067	0.143	
5825	165	IEEE 802.11a	OFDM	14.5	14.22	0.19	0 mm	2	F227C	6	top	1:1	0.076	1.067	0.081	
5180	36	IEEE 802.11a	OFDM	14.5	14.14	0.14	0 mm	2	F227C	6	back	1:1	0.569	1.086	0.618	
5210	42	IEEE 802.11ac	OFDM	11.5	11.11	-0.16	0 mm	2	F227C	29.3	back	1:1	0.301	1.094	0.329	
5180	36	IEEE 802.11a	OFDM	14.5	14.14	-0.18	0 mm	2	F227C	6	front	1:1	0.110	1.086	0.119	
5180	36	IEEE 802.11a	OFDM	14.5	14.14	0.00	0 mm	2	F227C	6	top	1:1	0.166	1.086	0.180	
5260	52	IEEE 802.11a	OFDM	14.5	13.70	0.12	0 mm	2	F227C	6	back	1:1	0.589	1.202	0.708	
5290	58	IEEE 802.11ac	OFDM	11.5	10.70	-0.16	0 mm	2	F227C	29.3	back	1:1	0.306	1.202	0.368	
5260	52	IEEE 802.11a	OFDM	14.5	13.70	0.19	0 mm	2	F227C	6	front	1:1	0.096	1.202	0.115	
5260	52	IEEE 802.11a	OFDM	14.5	13.70	-0.06	0 mm	2	F227C	6	top	1:1	0.163	1.202	0.196	
5700	140	IEEE 802.11a	OFDM	14.5	14.21	-0.12	0 mm	2	F227C	6	back	1:1	1.240	1.069	1.326	A29
5530	106	IEEE 802.11ac	OFDM	11.5	10.73	-0.14	0 mm	2	F227C	29.3	back	1:1	0.218	1.194	0.260	
5700	140	IEEE 802.11a	OFDM	14.5	14.21	-0.20	0 mm	2	F227C	6	front	1:1	0.133	1.069	0.142	
5700	140	IEEE 802.11a	OFDM	14.5	14.21	-0.13	0 mm	2	F227C	6	top	1:1	0.120	1.069	0.128	
5765	153	IEEE 802.11n	OFDM	13.5	13.01	0.20	0 mm	MIMO	F227C	13	back	1:1	0.124	1.119	0.139	
5765	153	IEEE 802.11n	OFDM	13.5	13.01	-0.04	0 mm	MIMO	F227C	13	front	1:1	0.017	1.119	0.019	
5765	153	IEEE 802.11n	OFDM	13.5	13.01	0.13	0 mm	MIMO	F227C	13	top	1:1	0.024	1.119	0.027	
5765	153	IEEE 802.11n	OFDM	13.5	13.01	0.05	0 mm	MIMO	F227C	13	left	1:1	0.049	1.119	0.055	
5200	40	IEEE 802.11n	OFDM	13.5	12.59	0.02	0 mm	MIMO	F227C	13	back	1:1	0.142	1.233	0.175	
5200	40	IEEE 802.11n	OFDM	13.5	12.59	0.19	0 mm	MIMO	F227C	13	front	1:1	0.040	1.233	0.049	
5200	40	IEEE 802.11n	OFDM	13.5	12.59	0.03	0 mm	MIMO	F227C	13	top	1:1	0.047	1.233	0.058	
5200	40	IEEE 802.11n	OFDM	13.5	12.59	0.16	0 mm	MIMO	F227C	13	left	1:1	0.064	1.233	0.079	
5320	64	IEEE 802.11n	OFDM	13.5	12.44	0.15	0 mm	MIMO	F227C	13	back	1:1	0.128	1.276	0.163	
5320	64	IEEE 802.11n	OFDM	13.5	12.44	0.15	0 mm	MIMO	F227C	13	front	1:1	0.040	1.276	0.051	
5320	64	IEEE 802.11n	OFDM	13.5	12.44	-0.10	0 mm	MIMO	F227C	13	top	1:1	0.050	1.276	0.064	
5320	64	IEEE 802.11n	OFDM	13.5	12.44	0.15	0 mm	MIMO	F227C	13	left	1:1	0.041	1.276	0.052	
5500	100	IEEE 802.11n	OFDM	13.5	12.63	0.15	0 mm	MIMO	F227C	13	back	1:1	0.130	1.222	0.159	
5500	100	IEEE 802.11n	OFDM	13.5	12.63	0.13	0 mm	MIMO	F227C	13	front	1:1	0.037	1.222	0.045	
5500	100	IEEE 802.11n	OFDM	13.5	12.63	-0.06	0 mm	MIMO	F227C	13	top	1:1	0.044	1.222	0.054	
5500	100	IEEE 802.11n	OFDM	13.5	12.63	0.11	0 mm	MIMO	F227C	13	left	1:1	0.036	1.222	0.044	

ANSI / IEEE C95.1 1992 - SAFETY LIMIT
Spatial Peak
Uncontrolled Exposure/General Population

Hand
4.0 W/kg (mW/g)
averaged over 10 grams

FCC ID: A3LSMN915G		SAR EVALUATION REPORT		Reviewed by: Quality Manager
Document S/N: OY1408121709.A3L	Test Dates: 08/14/14 - 08/18/14	DUT Type: Portable Handset		Page 55 of 73

11.5 SAR Test Notes

General Notes:



1. The test data reported are the worst-case SAR values according to test procedures specified in IEEE 1528-2003, and FCC KDB Publication 447498 D01v05.
2. Batteries are fully charged at the beginning of the SAR measurements.
3. Liquid tissue depth was at least 15.0 cm for all frequencies.
4. The manufacturer has confirmed that the device(s) tested have the same physical, mechanical and thermal characteristics and are within operational tolerances expected for production units.
5. SAR results were scaled to the maximum allowed power to demonstrate compliance per FCC KDB Publication 447498 D01v05.
6. Device was tested using a fixed spacing for body-worn accessory testing. A separation distance of 10 mm was considered because the manufacturer has determined that there will be body-worn accessories available in the marketplace for users to support this separation distance.
7. Per FCC KDB Publication 648474 D04v01, body-worn SAR was evaluated without a headset connected to the device. Since the standalone reported body-worn SAR was ≤ 1.2 W/kg, no additional body-worn SAR evaluations using a headset cable were required.
8. Per FCC KDB 865664 D01 v01, variability SAR tests were not performed since the measured SAR results for a frequency band were less than 0.8 W/kg for 1g SAR and 2.0 W/kg for 10g SAR. Please see Section 13 for variability analysis.
9. During SAR Testing for the Wireless Router conditions per FCC KDB Publication 941225 D06v01, the actual Portable Hotspot operation (with actual simultaneous transmission of a transmitter with WIFI) was not activated (See Section 6.7 for more details).
10. Per FCC KDB Publication 648474 D04v01r01, this device is considered a "phablet" since the diagonal dimension is > 160 mm and < 200 mm. Therefore, hand SAR tests are required when wireless router mode does not apply or if wireless router 1g SAR > 1.2 W/kg.

GSM Test Notes:

1. Body-Worn accessory testing is typically associated with voice operations. Therefore, GSM voice was evaluated for body-worn SAR.
2. Justification for reduced test configurations per KDB Publication 941225 D03v01 and October 2013 TCB Workshop Notes: The source-based frame-averaged output power was evaluated for all GPRS/EDGE slot configurations. The configuration with the highest target frame averaged output power was evaluated for hotspot SAR. When the maximum frame-averaged powers are equivalent across two or more slots (within 0.25 dB), the configuration with the most number of time slots was tested.
3. Per FCC KDB Publication 447498 D01v05, if the reported (scaled) SAR measured at the middle channel or highest output power channel for each test configuration is ≤ 0.8 W/kg then testing at the other channels is not required for such test configuration(s). When the maximum output power variation across the required test channels is $> \frac{1}{2}$ dB, instead of the middle channel, the highest output power channel was used.

UMTS Notes:

1. UMTS mode in was tested under RMC 12.2 kbps with HSPA Inactive per KDB Publication 941225 D01v02. HSPA SAR was not required since the average output power of the HSPA subtests was not more than 0.25 dB higher than the RMC level and SAR was less than 1.2 W/kg.
2. Per FCC KDB Publication 447498 D01v05, if the reported (scaled) SAR measured at the middle channel or highest output power channel for each test configuration is ≤ 0.8 W/kg then testing at the other channels is not required for such test configuration(s). When the maximum output power variation across the required test channels is $> \frac{1}{2}$ dB, instead of the middle channel, the highest output power channel was used.



FCC ID: A3LSMN915G		SAR EVALUATION REPORT		Reviewed by: Quality Manager
Document S/N: OY1408121709.A3L	Test Dates: 08/14/14 - 08/18/14	DUT Type: Portable Handset		Page 56 of 73

LTE Notes:

1. LTE Considerations: LTE test configurations are determined according to SAR Evaluation Considerations for LTE Devices in FCC KDB Publication 941225 D05v02r01. The general test procedures used for testing can be found in Section 8.4.4.
2. MPR is permanently implemented for this device by the manufacturer. The specific manufacturer target MPR is indicated alongside the SAR results. MPR is enabled for this device, according to 3GPP TS36.101 Section 6.2.3 – 6.2.5 under Table 6.2.3-1.
3. A-MPR was disabled for all SAR tests by setting NS=01 on the base station simulator. SAR tests were performed with the same number of RB and RB offsets transmitting on all TTI frames (maximum TTI).

WLAN Notes:

1. Justification for reduced test configurations for WIFI channels per KDB Publication 248227 D01v01r02 and October 2012 FCC/TCB Meeting Notes for 2.4 GHz WIFI SISO operations: Highest average RF output power channel for the lowest data rate was selected for SAR evaluation in 802.11b. Other SISO IEEE 802.11 modes (including 802.11g/n) were not investigated since the average output powers over all channels and data rates were not more than 0.25 dB higher than the tested channel in the lowest data rate of IEEE 802.11b mode.
2. Justification for reduced test configurations for WIFI channels per KDB Publication 248227 D01v01r02 and October 2012 FCC/TCB Meeting Notes for SISO 5 GHz WIFI operations: Highest average RF output power channel for the lowest data rate was selected for SAR evaluation in 802.11a. Other IEEE SISO 802.11 modes (including 802.11n 20 MHz and 40 MHz bandwidths) were not investigated since the average output powers over all channels and data rates were not more than 0.25 dB higher than the tested channel in the lowest data rate of IEEE 802.11a mode.
3. Per April 2013 TCB Workshop notes, full SISO SAR tests for all IEEE 802.11ac configurations were not required because the average output power was not more than 0.25 dB higher than IEEE 802.11a mode. IEEE 802.11ac SISO was evaluated for the highest IEEE 802.11a position in each 5 GHz band and exposure condition.
4. When Hotspot is enabled, all 5 GHz bands are disabled. Therefore no 5 GHz WIFI Wireless Router SAR Data was required.
5. Per KDB 248227, SAR for MIMO was measured with both transmitting simultaneously and was evaluated in dependently of SISO operation. For 2.4 GHz MIMO, 20MHz 802.11n was evaluated. For 5 GHz MIMO, 20MHz 802.11n was evaluated.
6. WIFI transmission was verified using an uncalibrated spectrum analyzer.
7. Since the maximum extrapolated peak SAR of the zoom scan for the maximum output channel for 1g SAR is <1.6 W/kg and the reported 1g averaged SAR is <0.8 W/kg, 1g SAR testing on other default channels was not required. Since the reported 10g averaged SAR is <2.0 W/kg, SAR testing on other default channels was not required.

FCC ID: A3LSMN915G		SAR EVALUATION REPORT		Reviewed by: Quality Manager
Document S/N: OY1408121709.A3L	Test Dates: 08/14/14 - 08/18/14	DUT Type: Portable Handset	Page 57 of 73	

12 FCC MULTI-TX AND ANTENNA SAR CONSIDERATIONS

12.1 Introduction

The following procedures adopted from FCC KDB Publication 447498 D01v05 are applicable to handsets with built-in unlicensed transmitters such as 802.11a/b/g/n/ac and Bluetooth devices which may simultaneously transmit with the licensed transmitter.

12.2 Simultaneous Transmission Procedures

This device contains transmitters that may operate simultaneously. Therefore simultaneous transmission analysis is required. Per FCC KDB 447498 D01v05 IV.C.1.iii and IEEE 1528-2013 Section 6.3.4.1.2, simultaneous transmission SAR test exclusion may be applied when the sum of the 1-g SAR for all the simultaneous transmitting antennas in a specific physical test configuration is ≤ 1.6 W/kg. When standalone SAR is not required to be measured, per FCC KDB 447498 D01v05 4.3.2 2), the following equation must be used to estimate the standalone 1g SAR for simultaneous transmission assessment involving that transmitter.

$$\text{Estimated SAR} = \frac{\sqrt{f(\text{GHz})}}{7.5} * \frac{(\text{Max Power of channel, mW})}{\text{Min. Separation Distance, mm}}$$

**Table 12-1
Estimated SAR**

Mode	Frequency	Maximum Allowed Power	Separation Distance (Body)	Estimated SAR (Body)
	[MHz]	[dBm]	[mm]	[W/kg]
Bluetooth	2480	12.00	10	0.336



Note: Held-to ear configurations are not applicable to Bluetooth operations and therefore were not considered for simultaneous transmission. Per KDB Publication 447498 D01v05, the maximum power of the channel was rounded to the nearest mW before calculation.

Main antenna SAR testing was not required for extremity exposure conditions per FCC KDB 648474. Therefore, no further analysis was required to determine that possible simultaneous scenarios would not exceed the SAR limit.

12.3 Head SAR Simultaneous Transmission Analysis

**Table 12-2
Simultaneous Transmission Scenario with 2.4 GHz WLAN Ant 1 (Held to Ear)**

Simult Tx	Configuration	GSM 850 SAR (W/kg)	2.4 GHz WLAN Ant 1 SAR (W/kg)	Σ SAR (W/kg)	Simult Tx	Configuration	GSM 1900 SAR (W/kg)	2.4 GHz WLAN Ant 1 SAR (W/kg)	Σ SAR (W/kg)
Head SAR	Right Cheek	0.079	0.065	0.144	Head SAR	Right Cheek	0.146	0.065	0.211
	Right Tilt	0.042	0.048	0.090		Right Tilt	0.085	0.048	0.133
	Left Cheek	0.062	0.020	0.082		Left Cheek	0.072	0.020	0.092
	Left Tilt	0.034	0.020	0.054		Left Tilt	0.020	0.020	0.040

FCC ID: A3LSMN915G	 PCTEST PROVIDING EXCELLENCE, INC.	SAR EVALUATION REPORT		Reviewed by: Quality Manager
Document S/N: OY1408121709.A3L	Test Dates: 08/14/14 - 08/18/14	DUT Type: Portable Handset		Page 58 of 73

Simult Tx	Configuration	UMTS 850 SAR (W/kg)	2.4 GHz WLAN Ant 1 SAR (W/kg)	Σ SAR (W/kg)	Simult Tx	Configuration	UMTS 1900 SAR (W/kg)	2.4 GHz WLAN Ant 1 SAR (W/kg)	Σ SAR (W/kg)
Head SAR	Right Cheek	0.133	0.065	0.198	Head SAR	Right Cheek	0.249	0.065	0.314
	Right Tilt	0.062	0.048	0.110		Right Tilt	0.147	0.048	0.195
	Left Cheek	0.078	0.020	0.098		Left Cheek	0.086	0.020	0.106
	Left Tilt	0.046	0.020	0.066		Left Tilt	0.032	0.020	0.052
Simult Tx	Configuration	LTE Band 5 (Cell) SAR (W/kg)	2.4 GHz WLAN Ant 1 SAR (W/kg)	Σ SAR (W/kg)	Simult Tx	Configuration	LTE Band 4 (AWS) SAR (W/kg)	2.4 GHz WLAN Ant 1 SAR (W/kg)	Σ SAR (W/kg)
Head SAR	Right Cheek	0.095	0.065	0.160	Head SAR	Right Cheek	0.078	0.065	0.143
	Right Tilt	0.037	0.048	0.085		Right Tilt	0.048	0.048	0.096
	Left Cheek	0.055	0.020	0.075		Left Cheek	0.085	0.020	0.105
	Left Tilt	0.032	0.020	0.052		Left Tilt	0.048	0.020	0.068
Simult Tx	Configuration	LTE Band 2 (PCS) SAR (W/kg)	2.4 GHz WLAN Ant 1 SAR (W/kg)	Σ SAR (W/kg)					
Head SAR	Right Cheek	0.203	0.065	0.268					
	Right Tilt	0.157	0.048	0.205					
	Left Cheek	0.083	0.020	0.103					
	Left Tilt	0.043	0.020	0.063					

**Table 12-3
Simultaneous Transmission Scenario with 2.4 GHz WLAN Ant 2 (Held to Ear)**

Simult Tx	Configuration	GSM 850 SAR (W/kg)	2.4 GHz WLAN Ant 2 SAR (W/kg)	Σ SAR (W/kg)	Simult Tx	Configuration	GSM 1900 SAR (W/kg)	2.4 GHz WLAN Ant 2 SAR (W/kg)	Σ SAR (W/kg)
Head SAR	Right Cheek	0.079	0.205	0.284	Head SAR	Right Cheek	0.146	0.205	0.351
	Right Tilt	0.042	0.133	0.175		Right Tilt	0.085	0.133	0.218
	Left Cheek	0.062	0.133	0.195		Left Cheek	0.072	0.133	0.205
	Left Tilt	0.034	0.106	0.140		Left Tilt	0.020	0.106	0.126
Simult Tx	Configuration	UMTS 850 SAR (W/kg)	2.4 GHz WLAN Ant 2 SAR (W/kg)	Σ SAR (W/kg)	Simult Tx	Configuration	UMTS 1900 SAR (W/kg)	2.4 GHz WLAN Ant 2 SAR (W/kg)	Σ SAR (W/kg)
Head SAR	Right Cheek	0.133	0.205	0.338	Head SAR	Right Cheek	0.249	0.205	0.454
	Right Tilt	0.062	0.133	0.195		Right Tilt	0.147	0.133	0.280
	Left Cheek	0.078	0.133	0.211		Left Cheek	0.086	0.133	0.219
	Left Tilt	0.046	0.106	0.152		Left Tilt	0.032	0.106	0.138
Simult Tx	Configuration	LTE Band 5 (Cell) SAR (W/kg)	2.4 GHz WLAN Ant 2 SAR (W/kg)	Σ SAR (W/kg)	Simult Tx	Configuration	LTE Band 4 (AWS) SAR (W/kg)	2.4 GHz WLAN Ant 2 SAR (W/kg)	Σ SAR (W/kg)
Head SAR	Right Cheek	0.095	0.205	0.300	Head SAR	Right Cheek	0.078	0.205	0.283
	Right Tilt	0.037	0.133	0.170		Right Tilt	0.048	0.133	0.181
	Left Cheek	0.055	0.133	0.188		Left Cheek	0.085	0.133	0.218
	Left Tilt	0.032	0.106	0.138		Left Tilt	0.048	0.106	0.154
Simult Tx	Configuration	LTE Band 2 (PCS) SAR (W/kg)	2.4 GHz WLAN Ant 2 SAR (W/kg)	Σ SAR (W/kg)					
Head SAR	Right Cheek	0.203	0.205	0.408					
	Right Tilt	0.157	0.133	0.290					
	Left Cheek	0.083	0.133	0.216					
	Left Tilt	0.043	0.106	0.149					





FCC ID: A3LSMN915G		SAR EVALUATION REPORT		Reviewed by: Quality Manager
Document S/N: OY1408121709.A3L	Test Dates: 08/14/14 - 08/18/14	DUT Type: Portable Handset	Page 59 of 73	

Table 12-4
Simultaneous Transmission Scenario with 2.4 GHz WLAN MIMO (Held to Ear)

Simult Tx	Configuration	GSM 850 SAR (W/kg)	2.4 GHz WLAN MIMO SAR (W/kg)	Σ SAR (W/kg)	Simult Tx	Configuration	GSM 1900 SAR (W/kg)	2.4 GHz WLAN MIMO SAR (W/kg)	Σ SAR (W/kg)
Head SAR	Right Cheek	0.079	0.083	0.162	Head SAR	Right Cheek	0.146	0.083	0.229
	Right Tilt	0.042	0.058	0.100		Right Tilt	0.085	0.058	0.143
	Left Cheek	0.062	0.053	0.115		Left Cheek	0.072	0.053	0.125
	Left Tilt	0.034	0.041	0.075		Left Tilt	0.020	0.041	0.061
Simult Tx	Configuration	UMTS 850 SAR (W/kg)	2.4 GHz WLAN MIMO SAR (W/kg)	Σ SAR (W/kg)	Simult Tx	Configuration	UMTS 1900 SAR (W/kg)	2.4 GHz WLAN MIMO SAR (W/kg)	Σ SAR (W/kg)
Head SAR	Right Cheek	0.133	0.083	0.216	Head SAR	Right Cheek	0.249	0.083	0.332
	Right Tilt	0.062	0.058	0.120		Right Tilt	0.147	0.058	0.205
	Left Cheek	0.078	0.053	0.131		Left Cheek	0.086	0.053	0.139
	Left Tilt	0.046	0.041	0.087		Left Tilt	0.032	0.041	0.073
Simult Tx	Configuration	LTE Band 5 (Cell) SAR (W/kg)	2.4 GHz WLAN MIMO SAR (W/kg)	Σ SAR (W/kg)	Simult Tx	Configuration	LTE Band 4 (AWS) SAR (W/kg)	2.4 GHz WLAN MIMO SAR (W/kg)	Σ SAR (W/kg)
Head SAR	Right Cheek	0.095	0.083	0.178	Head SAR	Right Cheek	0.078	0.083	0.161
	Right Tilt	0.037	0.058	0.095		Right Tilt	0.048	0.058	0.106
	Left Cheek	0.055	0.053	0.108		Left Cheek	0.085	0.053	0.138
	Left Tilt	0.032	0.041	0.073		Left Tilt	0.048	0.041	0.089
Simult Tx	Configuration	LTE Band 2 (PCS) SAR (W/kg)	2.4 GHz WLAN MIMO SAR (W/kg)	Σ SAR (W/kg)					
Head SAR	Right Cheek	0.203	0.083	0.286					
	Right Tilt	0.157	0.058	0.215					
	Left Cheek	0.083	0.053	0.136					
	Left Tilt	0.043	0.041	0.084					

Table 12-5
Simultaneous Transmission Scenario with 5 GHz WLAN Ant 1 (Held to Ear)

Simult Tx	Configuration	GSM 850 SAR (W/kg)	5 GHz WLAN Ant 1 SAR (W/kg)	Σ SAR (W/kg)	Simult Tx	Configuration	GSM 1900 SAR (W/kg)	5 GHz WLAN Ant 1 SAR (W/kg)	Σ SAR (W/kg)
Head SAR	Right Cheek	0.079	0.087	0.166	Head SAR	Right Cheek	0.146	0.087	0.233
	Right Tilt	0.042	0.015	0.057		Right Tilt	0.085	0.015	0.100
	Left Cheek	0.062	0.024	0.086		Left Cheek	0.072	0.024	0.096
	Left Tilt	0.034	0.001	0.035		Left Tilt	0.020	0.001	0.021
Simult Tx	Configuration	UMTS 850 SAR (W/kg)	5 GHz WLAN Ant 1 SAR (W/kg)	Σ SAR (W/kg)	Simult Tx	Configuration	UMTS 1900 SAR (W/kg)	5 GHz WLAN Ant 1 SAR (W/kg)	Σ SAR (W/kg)
Head SAR	Right Cheek	0.133	0.087	0.220	Head SAR	Right Cheek	0.249	0.087	0.336
	Right Tilt	0.062	0.015	0.077		Right Tilt	0.147	0.015	0.162
	Left Cheek	0.078	0.024	0.102		Left Cheek	0.086	0.024	0.110
	Left Tilt	0.046	0.001	0.047		Left Tilt	0.032	0.001	0.033
Simult Tx	Configuration	LTE Band 5 (Cell) SAR (W/kg)	5 GHz WLAN Ant 1 SAR (W/kg)	Σ SAR (W/kg)	Simult Tx	Configuration	LTE Band 4 (AWS) SAR (W/kg)	5 GHz WLAN Ant 1 SAR (W/kg)	Σ SAR (W/kg)
Head SAR	Right Cheek	0.095	0.087	0.182	Head SAR	Right Cheek	0.078	0.087	0.165
	Right Tilt	0.037	0.015	0.052		Right Tilt	0.048	0.015	0.063
	Left Cheek	0.055	0.024	0.079		Left Cheek	0.085	0.024	0.109
	Left Tilt	0.032	0.001	0.033		Left Tilt	0.048	0.001	0.049

FCC ID: A3LSMN915G	 PCTEST <small>PRODUCING UNPRECEDENTED</small>	SAR EVALUATION REPORT		Reviewed by: Quality Manager
Document S/N: OY1408121709.A3L	Test Dates: 08/14/14 - 08/18/14	DUT Type: Portable Handset		Page 60 of 73

Simult Tx	Configuration	LTE Band 2 (PCS) SAR (W/kg)	5 GHz WLAN Ant 1 SAR (W/kg)	Σ SAR (W/kg)
Head SAR	Right Cheek	0.203	0.087	0.290
	Right Tilt	0.157	0.015	0.172
	Left Cheek	0.083	0.024	0.107
	Left Tilt	0.043	0.001	0.044



Table 12-6
Simultaneous Transmission Scenario with 5 GHz WLAN Ant 2 (Held to Ear)

Simult Tx	Configuration	GSM 850 SAR (W/kg)	5 GHz WLAN Ant 2 SAR (W/kg)	Σ SAR (W/kg)	Simult Tx	Configuration	GSM 1900 SAR (W/kg)	5 GHz WLAN Ant 2 SAR (W/kg)	Σ SAR (W/kg)
Head SAR	Right Cheek	0.079	0.105	0.184	Head SAR	Right Cheek	0.146	0.105	0.251
	Right Tilt	0.042	0.083	0.125		Right Tilt	0.085	0.083	0.168
	Left Cheek	0.062	0.090	0.152		Left Cheek	0.072	0.090	0.162
	Left Tilt	0.034	0.087	0.121		Left Tilt	0.020	0.087	0.107
Simult Tx	Configuration	UMTS 850 SAR (W/kg)	5 GHz WLAN Ant 2 SAR (W/kg)	Σ SAR (W/kg)	Simult Tx	Configuration	UMTS 1900 SAR (W/kg)	5 GHz WLAN Ant 2 SAR (W/kg)	Σ SAR (W/kg)
Head SAR	Right Cheek	0.133	0.105	0.238	Head SAR	Right Cheek	0.249	0.105	0.354
	Right Tilt	0.062	0.083	0.145		Right Tilt	0.147	0.083	0.230
	Left Cheek	0.078	0.090	0.168		Left Cheek	0.086	0.090	0.176
	Left Tilt	0.046	0.087	0.133		Left Tilt	0.032	0.087	0.119
Simult Tx	Configuration	LTE Band 5 (Cell) SAR (W/kg)	5 GHz WLAN Ant 2 SAR (W/kg)	Σ SAR (W/kg)	Simult Tx	Configuration	LTE Band 4 (AWS) SAR (W/kg)	5 GHz WLAN Ant 2 SAR (W/kg)	Σ SAR (W/kg)
Head SAR	Right Cheek	0.095	0.105	0.200	Head SAR	Right Cheek	0.078	0.105	0.183
	Right Tilt	0.037	0.083	0.120		Right Tilt	0.048	0.083	0.131
	Left Cheek	0.055	0.090	0.145		Left Cheek	0.085	0.090	0.175
	Left Tilt	0.032	0.087	0.119		Left Tilt	0.048	0.087	0.135

Simult Tx	Configuration	LTE Band 2 (PCS) SAR (W/kg)	5 GHz WLAN Ant 2 SAR (W/kg)	Σ SAR (W/kg)
Head SAR	Right Cheek	0.203	0.105	0.308
	Right Tilt	0.157	0.083	0.240
	Left Cheek	0.083	0.090	0.173
	Left Tilt	0.043	0.087	0.130

Table 12-7
Simultaneous Transmission Scenario with 5 GHz WLAN MIMO (Held to Ear)

Simult Tx	Configuration	GSM 850 SAR (W/kg)	5 GHz WLAN MIMO SAR (W/kg)	Σ SAR (W/kg)	Simult Tx	Configuration	GSM 1900 SAR (W/kg)	5 GHz WLAN MIMO SAR (W/kg)	Σ SAR (W/kg)
Head SAR	Right Cheek	0.079	0.015	0.094	Head SAR	Right Cheek	0.146	0.015	0.161
	Right Tilt	0.042	0.018	0.060		Right Tilt	0.085	0.018	0.103
	Left Cheek	0.062	0.018	0.080		Left Cheek	0.072	0.018	0.090
	Left Tilt	0.034	0.016	0.050		Left Tilt	0.020	0.016	0.036
Simult Tx	Configuration	UMTS 850 SAR (W/kg)	5 GHz WLAN MIMO SAR (W/kg)	Σ SAR (W/kg)	Simult Tx	Configuration	UMTS 1900 SAR (W/kg)	5 GHz WLAN MIMO SAR (W/kg)	Σ SAR (W/kg)
Head SAR	Right Cheek	0.133	0.015	0.148	Head SAR	Right Cheek	0.249	0.015	0.264
	Right Tilt	0.062	0.018	0.080		Right Tilt	0.147	0.018	0.165
	Left Cheek	0.078	0.018	0.096		Left Cheek	0.086	0.018	0.104
	Left Tilt	0.046	0.016	0.062		Left Tilt	0.032	0.016	0.048

FCC ID: A3LSMN915G		SAR EVALUATION REPORT		Reviewed by: Quality Manager
Document S/N: OY1408121709.A3L	Test Dates: 08/14/14 - 08/18/14	DUT Type: Portable Handset		Page 61 of 73

Simult Tx	Configuration	LTE Band 5 (Cell) SAR (W/kg)	5 GHz WLAN MIMO SAR (W/kg)	Σ SAR (W/kg)	Simult Tx	Configuration	LTE Band 4 (AWS) SAR (W/kg)	5 GHz WLAN MIMO SAR (W/kg)	Σ SAR (W/kg)
Head SAR	Right Cheek	0.095	0.015	0.110	Head SAR	Right Cheek	0.078	0.015	0.093
	Right Tilt	0.037	0.018	0.055		Right Tilt	0.048	0.018	0.066
	Left Cheek	0.055	0.018	0.073		Left Cheek	0.085	0.018	0.103
	Left Tilt	0.032	0.016	0.048		Left Tilt	0.048	0.016	0.064

Simult Tx	Configuration	LTE Band 2 (PCS) SAR (W/kg)	5 GHz WLAN MIMO SAR (W/kg)	Σ SAR (W/kg)
Head SAR	Right Cheek	0.203	0.015	0.218
	Right Tilt	0.157	0.018	0.175
	Left Cheek	0.083	0.018	0.101
	Left Tilt	0.043	0.016	0.059

12.4 Body-Worn Simultaneous Transmission Analysis

Table 12-8

Simultaneous Transmission Scenario with 2.4 GHz WLAN Ant 1 (Body-Worn at 1.0 cm)

Configuration	Mode	2G/3G/4G SAR (W/kg)	2.4 GHz WLAN Ant 1 SAR (W/kg)	Σ SAR (W/kg)
Back Side	GSM 850	0.278	0.074	0.352
Back Side	GSM 1900	0.210	0.074	0.284
Back Side	UMTS 850	0.372	0.074	0.446
Back Side	UMTS 1900	0.293	0.074	0.367
Back Side	LTE Band 5 (Cell)	0.303	0.074	0.377
Back Side	LTE Band 4 (AWS)	0.276	0.074	0.350
Back Side	LTE Band 2 (PCS)	0.230	0.074	0.304

Table 12-9

Simultaneous Transmission Scenario with 2.4 GHz WLAN Ant 2 (Body-Worn at 1.0 cm)

Configuration	Mode	2G/3G/4G SAR (W/kg)	2.4 GHz WLAN Ant 2 SAR (W/kg)	Σ SAR (W/kg)
Back Side	GSM 850	0.278	0.054	0.332
Back Side	GSM 1900	0.210	0.054	0.264
Back Side	UMTS 850	0.372	0.054	0.426
Back Side	UMTS 1900	0.293	0.054	0.347
Back Side	LTE Band 5 (Cell)	0.303	0.054	0.357
Back Side	LTE Band 4 (AWS)	0.276	0.054	0.330
Back Side	LTE Band 2 (PCS)	0.230	0.054	0.284



FCC ID: A3LSMN915G	 PCTEST PROVIDING EXCELLENCE,™	SAR EVALUATION REPORT		Reviewed by: Quality Manager
Document S/N: OY1408121709.A3L	Test Dates: 08/14/14 - 08/18/14	DUT Type: Portable Handset	Page 62 of 73	

Table 12-10
Simultaneous Transmission Scenario with 2.4 GHz WLAN MIMO (Body-Worn at 1.0 cm)

Configuration	Mode	2G/3G/4G SAR (W/kg)	2.4 GHz WLAN MIMO SAR (W/kg)	Σ SAR (W/kg)
Back Side	GSM 850	0.278	0.027	0.305
Back Side	GSM 1900	0.210	0.027	0.237
Back Side	UMTS 850	0.372	0.027	0.399
Back Side	UMTS 1900	0.293	0.027	0.320
Back Side	LTE Band 5 (Cell)	0.303	0.027	0.330
Back Side	LTE Band 4 (AWS)	0.276	0.027	0.303
Back Side	LTE Band 2 (PCS)	0.230	0.027	0.257

Table 12-11
Simultaneous Transmission Scenario with 5 GHz WLAN Ant 1 (Body-Worn at 1.0 cm)

Configuration	Mode	2G/3G/4G SAR (W/kg)	5 GHz WLAN Ant 1 SAR (W/kg)	Σ SAR (W/kg)
Back Side	GSM 850	0.278	0.282	0.560
Back Side	GSM 1900	0.210	0.282	0.492
Back Side	UMTS 850	0.372	0.282	0.654
Back Side	UMTS 1900	0.293	0.282	0.575
Back Side	LTE Band 5 (Cell)	0.303	0.282	0.585
Back Side	LTE Band 4 (AWS)	0.276	0.282	0.558
Back Side	LTE Band 2 (PCS)	0.230	0.282	0.512

Table 12-12
Simultaneous Transmission Scenario with 5 GHz WLAN Ant 2 (Body-Worn at 1.0 cm)

Configuration	Mode	2G/3G/4G SAR (W/kg)	5 GHz WLAN Ant 2 SAR (W/kg)	Σ SAR (W/kg)
Back Side	GSM 850	0.278	0.431	0.709
Back Side	GSM 1900	0.210	0.431	0.641
Back Side	UMTS 850	0.372	0.431	0.803
Back Side	UMTS 1900	0.293	0.431	0.724
Back Side	LTE Band 5 (Cell)	0.303	0.431	0.734
Back Side	LTE Band 4 (AWS)	0.276	0.431	0.707
Back Side	LTE Band 2 (PCS)	0.230	0.431	0.661

Table 12-13
Simultaneous Transmission Scenario with 5 GHz WLAN MIMO (Body-Worn at 1.0 cm)

Configuration	Mode	2G/3G/4G SAR (W/kg)	5 GHz WLAN MIMO SAR (W/kg)	Σ SAR (W/kg)
Back Side	GSM 850	0.278	0.158	0.436
Back Side	GSM 1900	0.210	0.158	0.368
Back Side	UMTS 850	0.372	0.158	0.530
Back Side	UMTS 1900	0.293	0.158	0.451
Back Side	LTE Band 5 (Cell)	0.303	0.158	0.461
Back Side	LTE Band 4 (AWS)	0.276	0.158	0.434
Back Side	LTE Band 2 (PCS)	0.230	0.158	0.388



FCC ID: A3LSMN915G		SAR EVALUATION REPORT		Reviewed by: Quality Manager
Document S/N: OY1408121709.A3L	Test Dates: 08/14/14 - 08/18/14	DUT Type: Portable Handset		Page 63 of 73

Table 12-14
Simultaneous Transmission Scenario with Bluetooth (Body-Worn at 1.0 cm)

Configuration	Mode	2G/3G/4G SAR (W/kg)	Bluetooth SAR (W/kg)	Σ SAR (W/kg)
Back Side	GSM 850	0.278	0.336	0.614
Back Side	GSM 1900	0.210	0.336	0.546
Back Side	UMTS 850	0.372	0.336	0.708
Back Side	UMTS 1900	0.293	0.336	0.629
Back Side	LTE Band 5 (Cell)	0.303	0.336	0.639
Back Side	LTE Band 4 (AWS)	0.276	0.336	0.612
Back Side	LTE Band 2 (PCS)	0.230	0.336	0.566



Note: Bluetooth SAR was not required to be measured per FCC KDB 447498. Estimated SAR results were used in the above table to determine simultaneous transmission SAR test exclusion.

12.5 Hotspot SAR Simultaneous Transmission Analysis

Per FCC KDB Publication 941225 D06v01, the devices edges with antennas more than 2.5 cm from edge are not required to be evaluated for SAR (“-”).

Table 12-15
Simultaneous Transmission Scenario (2.4 GHz Hotspot at 1.0 cm)

Simult Tx	Configuration	GPRS 850 SAR (W/kg)	2.4 GHz WLAN Ant 1 SAR (W/kg)	Σ SAR (W/kg)	Simult Tx	Configuration	GPRS 1900 SAR (W/kg)	2.4 GHz WLAN Ant 1 SAR (W/kg)	Σ SAR (W/kg)
Body SAR	Back	0.304	0.074	0.378	Body SAR	Back	0.211	0.074	0.285
	Front	0.334	0.013	0.347		Front	0.361	0.013	0.374
	Top	-	0.008	0.008		Top	-	0.008	0.008
	Bottom	0.240	-	0.240		Bottom	0.588	-	0.588
	Right	0.218	-	0.218		Right	0.033	-	0.033
	Left	0.081	0.020	0.101		Left	0.236	0.020	0.256
Body SAR	Back	0.372	0.074	0.446	Body SAR	Back	0.293	0.074	0.367
	Front	0.421	0.013	0.434		Front	0.366	0.013	0.379
	Top	-	0.008	0.008		Top	-	0.008	0.008
	Bottom	0.246	-	0.246		Bottom	0.561	-	0.561
	Right	0.239	-	0.239		Right	0.054	-	0.054
	Left	0.116	0.020	0.136		Left	0.229	0.020	0.249
Body SAR	Back	0.303	0.074	0.377	Body SAR	Back	0.276	0.074	0.350
	Front	0.385	0.013	0.398		Front	0.418	0.013	0.431
	Top	-	0.008	0.008		Top	-	0.008	0.008
	Bottom	0.222	-	0.222		Bottom	0.471	-	0.471
	Right	0.190	-	0.190		Right	0.036	-	0.036
	Left	0.072	0.020	0.092		Left	0.307	0.020	0.327



FCC ID: A3LSMN915G		SAR EVALUATION REPORT		Reviewed by: Quality Manager
Document S/N: OY1408121709.A3L	Test Dates: 08/14/14 - 08/18/14	DUT Type: Portable Handset	Page 64 of 73	

Simult Tx	Configuration	LTE Band 2 (PCS) SAR (W/kg)	2.4 GHz WLAN Ant 1 SAR (W/kg)	Σ SAR (W/kg)
Body SAR	Back	0.230	0.074	0.304
	Front	0.354	0.013	0.367
	Top	-	0.008	0.008
	Bottom	0.660	-	0.660
	Right	0.063	-	0.063
	Left	0.235	0.020	0.255

**Table 12-16
Simultaneous Transmission Scenario (2.4 GHz WLAN Ant 2 at 1.0 cm)**

Simult Tx	Configuration	GPRS 850 SAR (W/kg)	2.4 GHz WLAN Ant 2 SAR (W/kg)	Σ SAR (W/kg)	Simult Tx	Configuration	GPRS 1900 SAR (W/kg)	2.4 GHz WLAN Ant 2 SAR (W/kg)	Σ SAR (W/kg)
Body SAR	Back	0.304	0.054	0.358	Body SAR	Back	0.211	0.054	0.265
	Front	0.334	0.035	0.369		Front	0.361	0.035	0.396
	Top	-	0.005	0.005		Top	-	0.005	0.005
	Bottom	0.240	-	0.240		Bottom	0.588	-	0.588
	Right	0.218	-	0.218		Right	0.033	-	0.033
	Left	0.081	-	0.081		Left	0.236	-	0.236
Body SAR	Back	0.372	0.054	0.426	Body SAR	Back	0.293	0.054	0.347
	Front	0.421	0.035	0.456		Front	0.366	0.035	0.401
	Top	-	0.005	0.005		Top	-	0.005	0.005
	Bottom	0.246	-	0.246		Bottom	0.561	-	0.561
	Right	0.239	-	0.239		Right	0.054	-	0.054
	Left	0.116	-	0.116		Left	0.229	-	0.229
Body SAR	Back	0.303	0.054	0.357	Body SAR	Back	0.276	0.054	0.330
	Front	0.385	0.035	0.420		Front	0.418	0.035	0.453
	Top	-	0.005	0.005		Top	-	0.005	0.005
	Bottom	0.222	-	0.222		Bottom	0.471	-	0.471
	Right	0.190	-	0.190		Right	0.036	-	0.036
	Left	0.072	-	0.072		Left	0.307	-	0.307

Simult Tx	Configuration	LTE Band 2 (PCS) SAR (W/kg)	2.4 GHz WLAN Ant 2 SAR (W/kg)	Σ SAR (W/kg)
Body SAR	Back	0.230	0.054	0.284
	Front	0.354	0.035	0.389
	Top	-	0.005	0.005
	Bottom	0.660	-	0.660
	Right	0.063	-	0.063
	Left	0.235	-	0.235

FCC ID: A3LSMN915G		SAR EVALUATION REPORT		Reviewed by: Quality Manager
Document S/N: OY1408121709.A3L	Test Dates: 08/14/14 - 08/18/14	DUT Type: Portable Handset	Page 65 of 73	

**Table 12-17
Simultaneous Transmission Scenario (2.4 GHz WLAN MIMO at 1.0 cm)**

Simult Tx	Configuration	GPRS 850 SAR (W/kg)	2.4 GHz WLAN MIMO SAR (W/kg)	Σ SAR (W/kg)	Simult Tx	Configuration	GPRS 1900 SAR (W/kg)	2.4 GHz WLAN MIMO SAR (W/kg)	Σ SAR (W/kg)
Body SAR	Back	0.304	0.027	0.331	Body SAR	Back	0.211	0.027	0.238
	Front	0.334	0.014	0.348		Front	0.361	0.014	0.375
	Top	-	0.003	0.003		Top	-	0.003	0.003
	Bottom	0.240	-	0.240		Bottom	0.588	-	0.588
	Right	0.218	-	0.218		Right	0.033	-	0.033
	Left	0.081	0.004	0.085		Left	0.236	0.004	0.240
Simult Tx	Configuration	UMTS 850 SAR (W/kg)	2.4 GHz WLAN MIMO SAR (W/kg)	Σ SAR (W/kg)	Simult Tx	Configuration	UMTS 1900 SAR (W/kg)	2.4 GHz WLAN MIMO SAR (W/kg)	Σ SAR (W/kg)
Body SAR	Back	0.372	0.027	0.399	Body SAR	Back	0.293	0.027	0.320
	Front	0.421	0.014	0.435		Front	0.366	0.014	0.380
	Top	-	0.003	0.003		Top	-	0.003	0.003
	Bottom	0.246	-	0.246		Bottom	0.561	-	0.561
	Right	0.239	-	0.239		Right	0.054	-	0.054
	Left	0.116	0.004	0.120		Left	0.229	0.004	0.233
Simult Tx	Configuration	LTE Band 5 (Cell) SAR (W/kg)	2.4 GHz WLAN MIMO SAR (W/kg)	Σ SAR (W/kg)	Simult Tx	Configuration	LTE Band 4 (AWS) SAR (W/kg)	2.4 GHz WLAN MIMO SAR (W/kg)	Σ SAR (W/kg)
Body SAR	Back	0.303	0.027	0.330	Body SAR	Back	0.276	0.027	0.303
	Front	0.385	0.014	0.399		Front	0.418	0.014	0.432
	Top	-	0.003	0.003		Top	-	0.003	0.003
	Bottom	0.222	-	0.222		Bottom	0.471	-	0.471
	Right	0.190	-	0.190		Right	0.036	-	0.036
	Left	0.072	0.004	0.076		Left	0.307	0.004	0.311
Simult Tx	Configuration	LTE Band 2 (PCS) SAR (W/kg)	2.4 GHz WLAN MIMO SAR (W/kg)	Σ SAR (W/kg)					
Body SAR	Back	0.230	0.027	0.257					
	Front	0.354	0.014	0.368					
	Top	-	0.003	0.003					
	Bottom	0.660	-	0.660					
	Right	0.063	-	0.063					
	Left	0.235	0.004	0.239					

12.6 Simultaneous Transmission Conclusion

The above numerical summed SAR results for all the worst-case simultaneous transmission conditions were below the SAR limit. Therefore, the above analysis is sufficient to determine that simultaneous transmission cases will not exceed the SAR limit and therefore no measured volumetric simultaneous SAR summation is required per FCC KDB Publication 447498 D01v05 and IEEE 1528-2013 Section 6.3.4.1.2.

FCC ID: A3LSMN915G		SAR EVALUATION REPORT		Reviewed by: Quality Manager
Document S/N: OY1408121709.A3L	Test Dates: 08/14/14 - 08/18/14	DUT Type: Portable Handset	Page 66 of 73	



13 SAR MEASUREMENT VARIABILITY

13.1 Measurement Variability

Per FCC KDB Publication 865664 D01v01, SAR measurement variability was not assessed since measured 1g SAR each frequency band was below 0.8 W/kg and measured 10g SAR for each frequency band was below 2.0 W/kg.

13.2 Measurement Uncertainty



The measured SAR was <1.5 W/kg for all frequency bands. Therefore, per KDB Publication 865664 D01v01, the extended measurement uncertainty analysis per IEEE 1528-2003 was not required.

FCC ID: A3LSMN915G	 PCTEST PROVIDING EXCELLENCE, INC.	SAR EVALUATION REPORT		Reviewed by: Quality Manager
Document S/N: 0Y1408121709.A3L	Test Dates: 08/14/14 - 08/18/14	DUT Type: Portable Handset		Page 67 of 73

14 EQUIPMENT LIST

Manufacturer	Model	Description	Cal Date	Cal Interval	Cal Due	Serial Number
Agilent	8594A	(9kHz-2.9GHz) Spectrum Analyzer	N/A	N/A	N/A	3051A00187
Agilent	8648D	(9kHz-4GHz) Signal Generator	4/15/2014	Annual	4/15/2015	3629U00687
Agilent	8753ES	S-Parameter Network Analyzer	5/22/2014	Annual	5/22/2015	US39170118
Agilent	8753ES	S-Parameter Network Analyzer	10/29/2013	Annual	10/29/2014	US39170122
Agilent	E4438C	ESG Vector Signal Generator	4/25/2014	Annual	4/25/2015	MY42082385
Agilent	E4438C	ESG Vector Signal Generator	3/31/2014	Annual	3/31/2015	MY42082659
Agilent	E8257D	(250kHz-20GHz) Signal Generator	4/15/2014	Annual	4/15/2015	MY45470194
Agilent	N5182A	MXG Vector Signal Generator	4/15/2014	Annual	4/15/2015	MY47420651
Agilent	N5182A	MXG Vector Signal Generator	4/15/2014	Annual	4/15/2015	MY47420800
Agilent	N9020A	MXA Signal Analyzer	10/29/2013	Annual	10/29/2014	US46470561
Amplifier Research	15S1G6	Amplifier	CBT	N/A	CBT	433971
Amplifier Research	15S1G6	Amplifier	CBT	N/A	CBT	433972
Anritsu	MA24106A	USB Power Sensor	5/14/2014	Annual	5/14/2015	1231535
Anritsu	MA24106A	USB Power Sensor	5/14/2014	Annual	5/14/2015	1231538
Anritsu	MA24106A	USB Power Sensor	5/15/2014	Annual	5/15/2015	1244512
Anritsu	MA24106A	USB Power Sensor	5/14/2014	Annual	5/14/2015	1244515
Anritsu	MA2411B	Pulse Power Sensor	11/14/2013	Annual	11/14/2014	1126066
Anritsu	MA2411B	Pulse Power Sensor	3/25/2014	Annual	3/25/2015	1207470
Anritsu	ML2495A	Power Meter	10/31/2013	Annual	10/31/2014	1039008
Anritsu	MT8820C	Radio Communication Analyzer	12/12/2013	Annual	12/12/2014	6200901190
Control Company	4052	Long Stem Thermometer	9/27/2013	Biennial	9/27/2015	130567447
Control Company	36934-158	Wall-Mounted Thermometer	4/29/2014	Biennial	4/29/2016	122014488
Fisher Scientific	15-077-960	Digital Thermometer	11/6/2012	Biennial	11/6/2014	122640025
MCL	BW-N6W5+	6dB Attenuator	CBT	N/A	CBT	1139
MiniCircuits	SLP-2400+	Low Pass Filter	CBT	N/A	CBT	R8979500903
MiniCircuits	VLF-6000+	Low Pass Filter	CBT	N/A	CBT	N/A
MiniCircuits	VLF-6000+	Low Pass Filter	CBT	N/A	CBT	N/A
Mini-Circuits	BW-N20W5	Power Attenuator	CBT	N/A	CBT	1226
Mini-Circuits	BW-N20W5+	DC to 18 GHz Precision Fixed 20 dB Attenuator	CBT	N/A	CBT	N/A
Mini-Circuits	NLP-1200+	Low Pass Filter DC to 1000 MHz	CBT	N/A	CBT	N/A
Mini-Circuits	NLP-2950+	Low Pass Filter DC to 2700 MHz	CBT	N/A	CBT	N/A
Mitutoyo	CD-6°CSX	Digital Caliper	5/8/2014	Biennial	5/8/2016	13264162
Narda	4014C-6	4 - 8 GHz SMA 6 dB Directional Coupler	CBT	N/A	CBT	N/A
Narda	4772-3	Attenuator (3dB)	CBT	N/A	CBT	9406
Narda	BW-S3W2	Attenuator (3dB)	CBT	N/A	CBT	120
Pasternack	PE2208-6	Bidirectional Coupler	CBT	N/A	CBT	N/A
Pasternack	PE2209-10	Bidirectional Coupler	CBT	N/A	CBT	N/A
Rohde & Schwarz	CMW500	Radio Communication Tester	10/18/2013	Annual	10/18/2014	100976
Rohde & Schwarz	CMW500	Radio Communication Tester	2/20/2014	Annual	2/20/2015	128633
Seekonk	NC-100	Torque Wrench	3/18/2014	Biennial	3/18/2016	22313
SPEAG	D1765V2	1765 MHz SAR Dipole	5/7/2014	Annual	5/7/2015	1008
SPEAG	D1900V2	1900 MHz SAR Dipole	4/9/2014	Annual	4/9/2015	5d141
SPEAG	D1900V2	1900 MHz SAR Dipole	2/27/2014	Annual	2/27/2015	5d148
SPEAG	D2450V2	2450 MHz SAR Dipole	1/21/2014	Annual	1/21/2015	797
SPEAG	D5GHzV2	5 GHz SAR Dipole	9/23/2013	Annual	9/23/2014	1007
SPEAG	D5GHzV2	5 GHz SAR Dipole	1/27/2014	Annual	1/27/2015	1057
SPEAG	D835V2	835 MHz SAR Dipole	4/7/2014	Annual	4/7/2015	4d119
SPEAG	D835V2	835 MHz SAR Dipole	7/10/2014	Annual	7/10/2015	4d132
SPEAG	DAE4	Dasy Data Acquisition Electronics	12/12/2013	Annual	12/12/2014	649
SPEAG	DAE4	Dasy Data Acquisition Electronics	5/14/2014	Annual	5/14/2015	859
SPEAG	DAE4	Dasy Data Acquisition Electronics	9/17/2013	Annual	9/17/2014	1323
SPEAG	DAE4	Dasy Data Acquisition Electronics	11/19/2013	Annual	11/19/2014	1333
SPEAG	DAE4	Dasy Data Acquisition Electronics	3/17/2014	Annual	3/17/2015	1364
SPEAG	DAE4	Dasy Data Acquisition Electronics	4/11/2014	Annual	4/11/2015	1368
SPEAG	DAE4	Dasy Data Acquisition Electronics	11/18/2013	Annual	11/18/2014	1407
SPEAG	DAE4	Dasy Data Acquisition Electronics	11/19/2013	Annual	11/19/2014	1408
SPEAG	DAK-3.5	Dielectric Assessment Kit	5/6/2014	Annual	5/6/2015	1070
SPEAG	DAK-3.5	Dielectric Assessment Kit	11/13/2013	Annual	11/13/2014	1091
SPEAG	ES3DV3	SAR Probe	4/11/2014	Annual	4/11/2015	3213
SPEAG	ES3DV3	SAR Probe	5/15/2014	Annual	5/15/2015	3263
SPEAG	ES3DV3	SAR Probe	11/20/2013	Annual	11/20/2014	3287
SPEAG	ES3DV3	SAR Probe	9/23/2013	Annual	9/23/2014	3288
SPEAG	ES3DV3	SAR Probe	4/17/2014	Annual	4/17/2015	3319
SPEAG	ES3DV3	SAR Probe	11/25/2013	Annual	11/25/2014	3332
SPEAG	EX3DV4	SAR Probe	10/23/2013	Annual	10/23/2014	3914
SPEAG	EX3DV4	SAR Probe	12/18/2013	Annual	12/18/2014	3920
VWR	36934-158	Wall-Mounted Thermometer	4/29/2014	Biennial	4/29/2016	111859323

Note: CBT (Calibrated Before Testing). Prior to testing, the measurement paths containing a cable, amplifier, attenuator, coupler or filter were connected to a calibrated source (i.e. a signal generator) to determine the losses of the measurement path. The power meter offset was then adjusted to compensate for the measurement system losses. This level offset is stored within the power meter before measurements are made. This calibration verification procedure applies to the system verification and output power measurements. The calibrated reading is then taken directly from the power meter after compensation of the losses for all final power measurements.



FCC ID: A3LSMN915G		SAR EVALUATION REPORT		Reviewed by: Quality Manager
Document S/N: OY1408121709.A3L	Test Dates: 08/14/14 - 08/18/14	DUT Type: Portable Handset	Page 68 of 73	

15 MEASUREMENT UNCERTAINTIES

Applicable for frequencies less than 3000 MHz.

a	b	c	d	e= f(d,k)	f	g	h = c x f/e	i = c x g/e	k	
Uncertainty Component	IEEE 1528 Sec.	Tol. (± %)	Prob. Dist.	Div.	c _i 1gm	c _i 10 gms	1gm u _i (± %)	10gms u _i (± %)	v _i	
Measurement System										
Probe Calibration	E.2.1	6.0	N	1	1.0	1.0	6.0	6.0	∞	
Axial Isotropy	E.2.2	0.25	N	1	0.7	0.7	0.2	0.2	∞	
Hemishperical Isotropy	E.2.2	1.3	N	1	1.0	1.0	1.3	1.3	∞	
Boundary Effect	E.2.3	0.4	N	1	1.0	1.0	0.4	0.4	∞	
Linearity	E.2.4	0.3	N	1	1.0	1.0	0.3	0.3	∞	
System Detection Limits	E.2.5	5.1	N	1	1.0	1.0	5.1	5.1	∞	
Readout Electronics	E.2.6	1.0	N	1	1.0	1.0	1.0	1.0	∞	
Response Time	E.2.7	0.8	R	1.73	1.0	1.0	0.5	0.5	∞	
Integration Time	E.2.8	2.6	R	1.73	1.0	1.0	1.5	1.5	∞	
RF Ambient Conditions	E.6.1	3.0	R	1.73	1.0	1.0	1.7	1.7	∞	
Probe Positioner Mechanical Tolerance	E.6.2	0.4	R	1.73	1.0	1.0	0.2	0.2	∞	
Probe Positioning w/ respect to Phantom	E.6.3	2.9	R	1.73	1.0	1.0	1.7	1.7	∞	
Extrapolation, Interpolation & Integration algorithms for Max. SAR Evaluation	E.5	1.0	R	1.73	1.0	1.0	0.6	0.6	∞	
Test Sample Related										
Test Sample Positioning	E.4.2	6.0	N	1	1.0	1.0	6.0	6.0	287	
Device Holder Uncertainty	E.4.1	3.32	R	1.73	1.0	1.0	1.9	1.9	∞	
Output Power Variation - SAR drift measurement	6.6.2	5.0	R	1.73	1.0	1.0	2.9	2.9	∞	
Phantom & Tissue Parameters										
Phantom Uncertainty (Shape & Thickness tolerances)	E.3.1	4.0	R	1.73	1.0	1.0	2.3	2.3	∞	
Liquid Conductivity - deviation from target values	E.3.2	5.0	R	1.73	0.64	0.43	1.8	1.2	∞	
Liquid Conductivity - measurement uncertainty	E.3.3	3.8	N	1	0.64	0.43	2.4	1.6	6	
Liquid Permittivity - deviation from target values	E.3.2	5.0	R	1.73	0.60	0.49	1.7	1.4	∞	
Liquid Permittivity - measurement uncertainty	E.3.3	4.5	N	1	0.60	0.49	2.7	2.2	6	
Combined Standard Uncertainty (k=1)							RSS	12.1	11.7	299
Expanded Uncertainty (95% CONFIDENCE LEVEL)							k=2	24.2	23.5	



The above measurement uncertainties are according to IEEE Std. 1528-2003

FCC ID: A3LSMN915G	 PCTEST PROVIDING UNPRECEDENTED	SAR EVALUATION REPORT		Reviewed by: Quality Manager
Document S/N: OY1408121709.A3L	Test Dates: 08/14/14 - 08/18/14	DUT Type: Portable Handset	Page 69 of 73	

Applicable for frequencies up to 6 GHz.

a	b	c	d	e= f(d,k)	f	g	h = c x f/e	i = c x g/e	k	
Uncertainty Component	IEEE 1528 Sec.	Tol. (± %)	Prob. Dist.	Div.	c _i 1gm	c _i 10 gms	1gm u _i (± %)	10gms u _i (± %)	v _i	
Measurement System										
Probe Calibration	E.2.1	6.55	N	1	1.0	1.0	6.6	6.6	∞	
Axial Isotropy	E.2.2	0.25	N	1	0.7	0.7	0.2	0.2	∞	
Hemishperical Isotropy	E.2.2	1.3	N	1	1.0	1.0	1.3	1.3	∞	
Boundary Effect	E.2.3	0.4	N	1	1.0	1.0	0.4	0.4	∞	
Linearity	E.2.4	0.3	N	1	1.0	1.0	0.3	0.3	∞	
System Detection Limits	E.2.5	5.1	N	1	1.0	1.0	5.1	5.1	∞	
Readout Electronics	E.2.6	1.0	N	1	1.0	1.0	1.0	1.0	∞	
Response Time	E.2.7	0.8	R	1.73	1.0	1.0	0.5	0.5	∞	
Integration Time	E.2.8	2.6	R	1.73	1.0	1.0	1.5	1.5	∞	
RF Ambient Conditions	E.6.1	3.0	R	1.73	1.0	1.0	1.7	1.7	∞	
Probe Positioner Mechanical Tolerance	E.6.2	0.4	R	1.73	1.0	1.0	0.2	0.2	∞	
Probe Positioning w/ respect to Phantom	E.6.3	2.9	R	1.73	1.0	1.0	1.7	1.7	∞	
Extrapolation, Interpolation & Integration algorithms for Max. SAR Evaluation	E.5	1.0	R	1.73	1.0	1.0	0.6	0.6	∞	
Test Sample Related										
Test Sample Positioning	E.4.2	6.0	N	1	1.0	1.0	6.0	6.0	287	
Device Holder Uncertainty	E.4.1	3.32	R	1.73	1.0	1.0	1.9	1.9	∞	
Output Power Variation - SAR drift measurement	6.6.2	5.0	R	1.73	1.0	1.0	2.9	2.9	∞	
Phantom & Tissue Parameters										
Phantom Uncertainty (Shape & Thickness tolerances)	E.3.1	4.0	R	1.73	1.0	1.0	2.3	2.3	∞	
Liquid Conductivity - deviation from target values	E.3.2	5.0	R	1.73	0.64	0.43	1.8	1.2	∞	
Liquid Conductivity - measurement uncertainty	E.3.3	3.8	N	1	0.64	0.43	2.4	1.6	6	
Liquid Permittivity - deviation from target values	E.3.2	5.0	R	1.73	0.60	0.49	1.7	1.4	∞	
Liquid Permittivity - measurement uncertainty	E.3.3	4.5	N	1	0.60	0.49	2.7	2.2	6	
Combined Standard Uncertainty (k=1)							RSS	12.4	12.0	299
Expanded Uncertainty (95% CONFIDENCE LEVEL)							k=2	24.7	24.0	

The above measurement uncertainties are according to IEEE Std. 1528-2003



FCC ID: A3LSMN915G	 PCTEST PROVIDING UNPRECEDENTED	SAR EVALUATION REPORT		Reviewed by: Quality Manager
Document S/N: OY1408121709.A3L	Test Dates: 08/14/14 - 08/18/14	DUT Type: Portable Handset	Page 70 of 73	

16 CONCLUSION

16.1 Measurement Conclusion



The SAR evaluation indicates that the EUT complies with the RF radiation exposure limits of the FCC and Industry Canada, with respect to all parameters subject to this test. These measurements were taken to simulate the RF effects of RF exposure under worst-case conditions. Precise laboratory measures were taken to assure repeatability of the tests. The results and statements relate only to the item(s) tested.

Please note that the absorption and distribution of electromagnetic energy in the body are very complex phenomena that depend on the mass, shape, and size of the body, the orientation of the body with respect to the field vectors, and the electrical properties of both the body and the environment. Other variables that may play a substantial role in possible biological effects are those that characterize the environment (e.g. ambient temperature, air velocity, relative humidity, and body insulation) and those that characterize the individual (e.g. age, gender, activity level, debilitation, or disease). Because various factors may interact with one another to vary the specific biological outcome of an exposure to electromagnetic fields, any protection guide should consider maximal amplification of biological effects as a result of field-body interactions, environmental conditions, and physiological variables. [3]



FCC ID: A3LSMN915G	 PCTEST ENGINEERING LABORATORY, INC.	SAR EVALUATION REPORT		Reviewed by: Quality Manager
Document S/N: 0Y1408121709.A3L	Test Dates: 08/14/14 - 08/18/14	DUT Type: Portable Handset		Page 71 of 73

17 REFERENCES

- [1] Federal Communications Commission, ET Docket 93-62, Guidelines for Evaluating the Environmental Effects of Radiofrequency Radiation, Aug. 1996.
- [2] ANSI/IEEE C95.1-2005, American National Standard safety levels with respect to human exposure to radio frequency electromagnetic fields, 3kHz to 300GHz, New York: IEEE, 2006.
- [3] ANSI/IEEE C95.1-1992, American National Standard safety levels with respect to human exposure to radio frequency electromagnetic fields, 3kHz to 300GHz, New York: IEEE, Sept. 1992.
- [4] ANSI/IEEE C95.3-2002, IEEE Recommended Practice for the Measurement of Potentially Hazardous Electromagnetic Fields - RF and Microwave, New York: IEEE, December 2002.
- [5] IEEE Standards Coordinating Committee 39 –Standards Coordinating Committee 34 – IEEE Std. 1528-2003, Recommended Practice for Determining the Peak Spatial-Average Specific Absorption Rate (SAR) in the Human Head Due to Wireless Communications Devices: Measurement Techniques.
- [6] NCRP, National Council on Radiation Protection and Measurements, Biological Effects and Exposure Criteria for RadioFrequency Electromagnetic Fields, NCRP Report No. 86, 1986. Reprinted Feb. 1995.
- [7] T. Schmid, O. Egger, N. Kuster, Automated E-field scanning system for dosimetric assessments, IEEE Transaction on Microwave Theory and Techniques, vol. 44, Jan. 1996, pp. 105-113.
- [8] K. Pokovic, T. Schmid, N. Kuster, Robust setup for precise calibration of E-field probes in tissue simulating liquids at mobile communications frequencies, ICECOM97, Oct. 1997, pp. -124.
- [9] K. Pokovic, T. Schmid, and N. Kuster, E-field Probe with improved isotropy in brain simulating liquids, Proceedings of the ELMAR, Zadar, Croatia, June 23-25, 1996, pp. 172-175.
- [10] Schmid & Partner Engineering AG, Application Note: Data Storage and Evaluation, June 1998, p2.
- [11] V. Hombach, K. Meier, M. Burkhardt, E. Kuhn, N. Kuster, The Dependence of EM Energy Absorption upon Human Modeling at 900 MHz, IEEE Transaction on Microwave Theory and Techniques, vol. 44 no. 10, Oct. 1996, pp. 1865-1873.
- [12] N. Kuster and Q. Balzano, Energy absorption mechanism by biological bodies in the near field of dipole antennas above 300MHz, IEEE Transaction on Vehicular Technology, vol. 41, no. 1, Feb. 1992, pp. 17-23.
- [13] G. Hartsgrove, A. Kraszewski, A. Surowiec, Simulated Biological Materials for Electromagnetic Radiation Absorption Studies, University of Ottawa, Bioelectromagnetics, Canada: 1987, pp. 29-36.
- [14] Q. Balzano, O. Garay, T. Manning Jr., Electromagnetic Energy Exposure of Simulated Users of Portable Cellular Telephones, IEEE Transactions on Vehicular Technology, vol. 44, no.3, Aug. 1995.
- [15] W. Gander, Computermathematick, Birkhaeuser, Basel, 1992.
- [16] W.H. Press, S.A. Teukolsky, W.T. Vetterling, and B.P. Flannery, Numerical Recipes in C, The Art of Scientific Computing, Second edition, Cambridge University Press, 1992.
- [17] N. Kuster, R. Kastle, T. Schmid, Dosimetric evaluation of mobile communications equipment with known precision, IEEE Transaction on Communications, vol. E80-B, no. 5, May 1997, pp. 645-652.

FCC ID: A3LSMN915G	 PCTEST Engineering Laboratory, Inc.	SAR EVALUATION REPORT		Reviewed by: Quality Manager
Document S/N: OY1408121709.A3L	Test Dates: 08/14/14 - 08/18/14	DUT Type: Portable Handset	Page 72 of 73	

- [18] CENELEC CLC/SC111B, European Prestandard (prENV 50166-2), Human Exposure to Electromagnetic Fields High-frequency: 10kHz-300GHz, Jan. 1995.
- [19] Prof. Dr. Niels Kuster, ETH, Eidgenössische Technische Hochschule Zürich, Dosimetric Evaluation of the Cellular Phone.
- [20] IEC 62209-1, Human exposure to radio frequency fields from hand-held and body-mounted wireless communication devices - Human models, instrumentation, and procedures - Part 1: Procedure to determine the specific absorption rate (SAR) for hand-held devices used in close proximity to the ear (frequency range of 300 MHz to 3 GHz), Feb. 2005.
- [21] Industry Canada RSS-102 Radio Frequency Exposure Compliance of Radiocommunication Apparatus (All Frequency Bands) Issue 4, March 2010.
- [22] Health Canada Safety Code 6 Limits of Human Exposure to Radio Frequency Electromagnetic Fields in the Frequency Range from 3 kHz – 300 GHz, 2009
- [23] FCC SAR Test Procedures for 2G-3G Devices, Mobile Hotspot and UMPC Devices KDB Publications 941225, D01-D07
- [24] SAR Measurement procedures for IEEE 802.11a/b/g KDB Publication 248227 D01v01r02
- [25] FCC SAR Considerations for Handsets with Multiple Transmitters and Antennas, KDB Publications 648474 D02-D04
- [26] FCC SAR Evaluation Considerations for Laptop, Notebook, Netbook and Tablet Computers, FCC KDB Publication 616217 D04
- [27] FCC SAR Measurement and Reporting Requirements for 100MHz – 6 GHz, KDB Publications 865664 D01-D02
- [28] FCC General RF Exposure Guidance and SAR Procedures for Dongles, KDB Publication 447498, D01-D02
- [29] Anexo à Resolução No. 533, de 10 de Setembro de 2009.
- [30] IEC 62209-2, Human exposure to radio frequency fields from hand-held and body-mounted wireless communication devices - Human models, instrumentation, and procedures - Part 2: Procedure to determine the specific absorption rate (SAR) for wireless communication devices used in close proximity to the human body (frequency range of 30 MHz to 6 GHz), Mar. 2010.

FCC ID: A3LSMN915G	 SAR EVALUATION REPORT 		Reviewed by: Quality Manager
Document S/N: OY1408121709.A3L	Test Dates: 08/14/14 - 08/18/14	DUT Type: Portable Handset	Page 73 of 73

APPENDIX A: SAR TEST DATA

PCTEST ENGINEERING LABORATORY, INC.

DUT: A3LSMN915G; Type: Portable Handset; Serial: F238A

Communication System: UID 0, GSM850; Frequency: 836.6 MHz; Duty Cycle: 1:8.3

Medium: 835 Head Medium parameters used (interpolated):

$f = 836.6 \text{ MHz}$; $\sigma = 0.924 \text{ S/m}$; $\epsilon_r = 41.92$; $\rho = 1000 \text{ kg/m}^3$

Phantom section: Right Section

Test Date: 08-18-2014; Ambient Temp: 23.7°C; Tissue Temp: 20.0°C

Probe: ES3DV3 - SN3213; ConvF(6.37, 6.37, 6.37); Calibrated: 4/11/2014;

Sensor-Surface: 3mm (Mechanical Surface Detection)

Electronics: DAE4 Sn1364; Calibrated: 3/17/2014

Phantom: SAM Sub; Type: SAM 4.0; Serial: TP-1357

Measurement SW: DASY4, Version 4.7 (80); SEMCAD X Version 14.6.10 (7331)

Mode: GSM 850, Right Head, Cheek, Mid.ch

Area Scan (9x14x1): Measurement grid: dx=15mm, dy=15mm

Zoom Scan (5x5x7)/Cube 0: Measurement grid: dx=8mm, dy=8mm, dz=5mm

Reference Value = 8.626 V/m; Power Drift = 0.17 dB

Peak SAR (extrapolated) = 0.0810 W/kg

SAR(1 g) = 0.067 W/kg

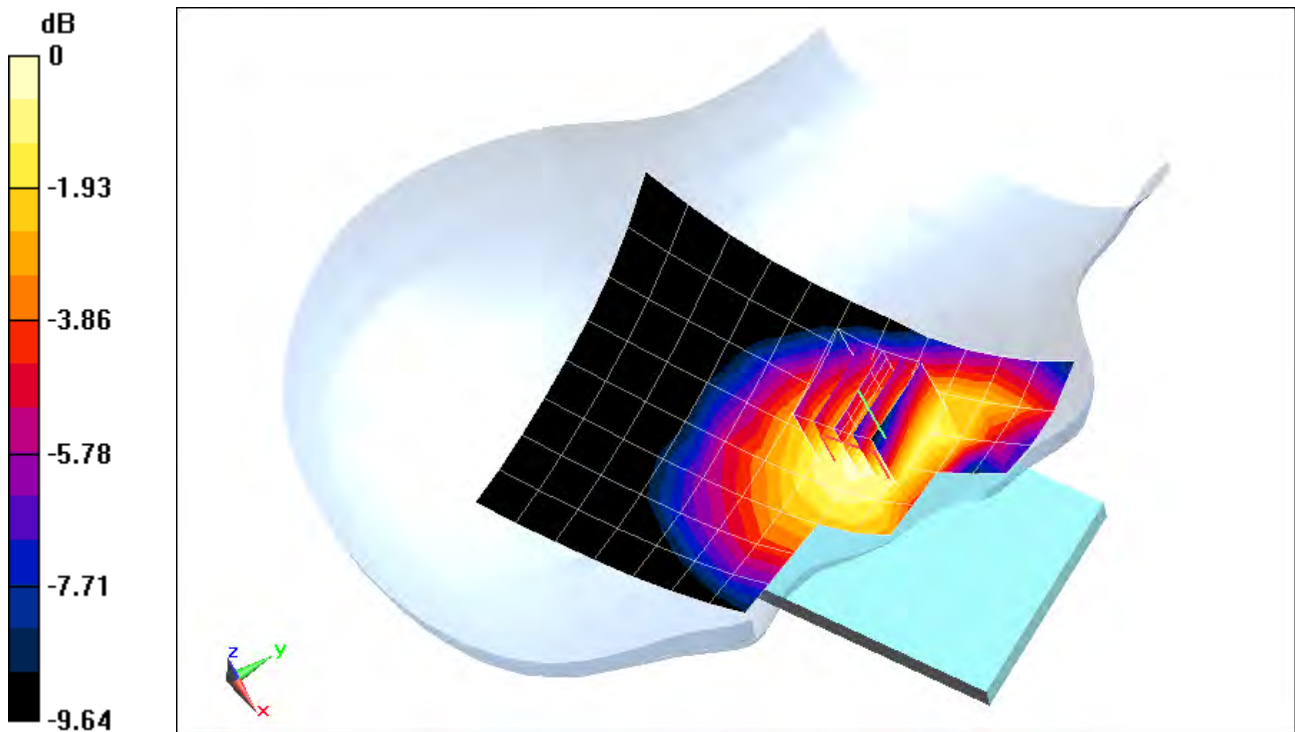

0 dB = 0.0732 W/kg = -11.35 dBW/kg

PCTEST ENGINEERING LABORATORY, INC.

DUT: A3LSMN915G; Type: Portable Handset; Serial: F227C

Communication System: UID 0, GSM1900; Frequency: 1880 MHz; Duty Cycle: 1:8.3

Medium: 1900 Head Medium parameters used:

$$f = 1880 \text{ MHz}; \sigma = 1.388 \text{ S/m}; \epsilon_r = 41.1; \rho = 1000 \text{ kg/m}^3$$

Phantom section: Right Section

Test Date: 08-14-2014; Ambient Temp: 21.8°C; Tissue Temp: 20.4°C

Probe: ES3DV3 - SN3213; ConvF(4.99, 4.99, 4.99); Calibrated: 4/11/2014;

Sensor-Surface: 3mm (Mechanical Surface Detection)

Electronics: DAE4 Sn1364; Calibrated: 3/17/2014

Phantom: SAM Main; Type: SAM 4.0; Serial: TP-1406

Measurement SW: DASY4, Version 4.7 (80); SEMCAD X Version 14.6.10 (7331)

Mode: GSM 1900, Right Head, Cheek, Mid.ch

Area Scan (9x14x1): Measurement grid: dx=15mm, dy=15mm

Zoom Scan (5x5x7)/Cube 0: Measurement grid: dx=8mm, dy=8mm, dz=5mm

Reference Value = 8.193 V/m; Power Drift = 0.15 dB

Peak SAR (extrapolated) = 0.281 W/kg

SAR(1 g) = 0.131 W/kg

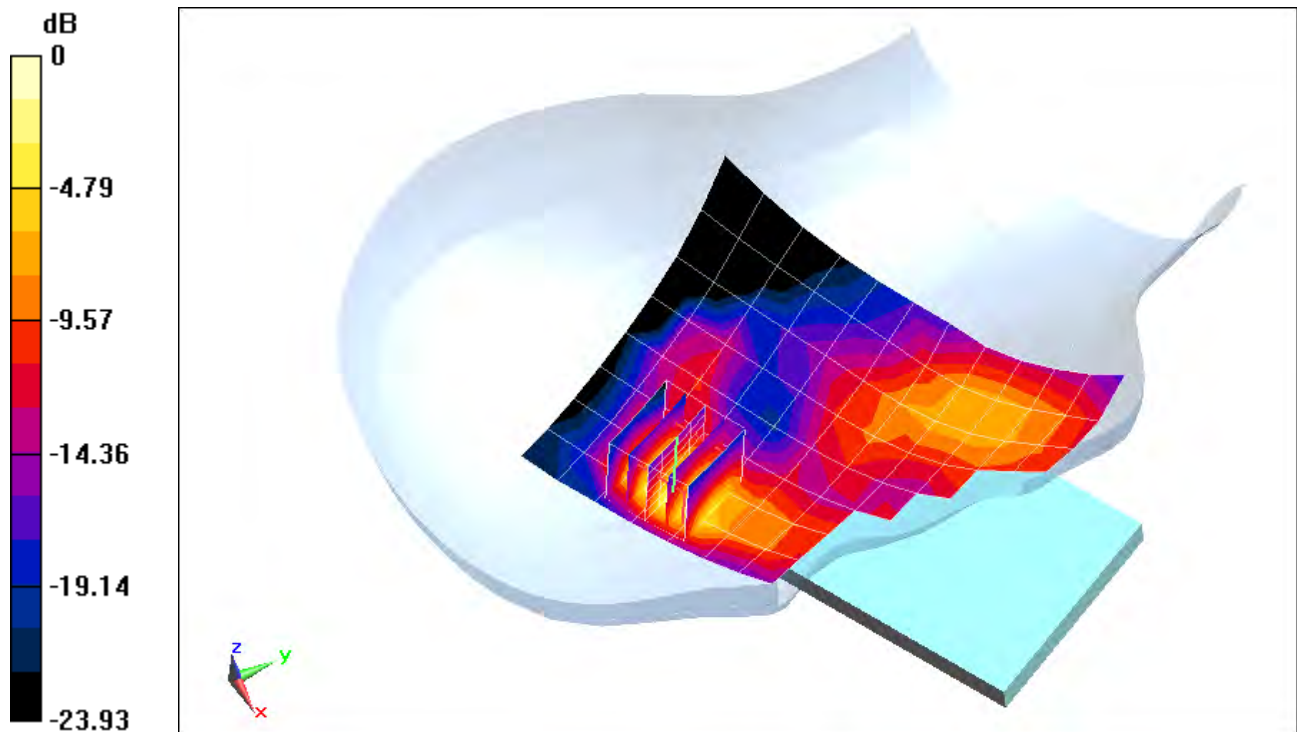

0 dB = 0.172 W/kg = -7.64 dBW/kg

PCTEST ENGINEERING LABORATORY, INC.

DUT: A3LSMN915G; Type: Portable Handset; Serial: F227C

Communication System: UID 0, WCDMA850; Frequency: 836.6 MHz; Duty Cycle: 1:1

Medium: 835 Head Medium parameters used (interpolated):

$f = 836.6 \text{ MHz}$; $\sigma = 0.913 \text{ S/m}$; $\epsilon_r = 42.158$; $\rho = 1000 \text{ kg/m}^3$

Phantom section: Right Section

Test Date: 08-15-2014; Ambient Temp: 22.3°C; Tissue Temp: 20.2°C

Probe: ES3DV3 - SN3213; ConvF(6.37, 6.37, 6.37); Calibrated: 4/11/2014;

Sensor-Surface: 3mm (Mechanical Surface Detection)

Electronics: DAE4 Sn1364; Calibrated: 3/17/2014

Phantom: SAM Sub; Type: SAM 4.0; Serial: TP-1357

Measurement SW: DASY4, Version 4.7 (80); SEMCAD X Version 14.6.10 (7331)

Mode: UMTS 850, Right Head, Cheek, Mid.ch

Area Scan (9x14x1): Measurement grid: dx=15mm, dy=15mm

Zoom Scan (5x5x7)/Cube 0: Measurement grid: dx=8mm, dy=8mm, dz=5mm

Reference Value = 11.50 V/m; Power Drift = 0.03 dB

Peak SAR (extrapolated) = 0.143 W/kg

SAR(1 g) = 0.116 W/kg

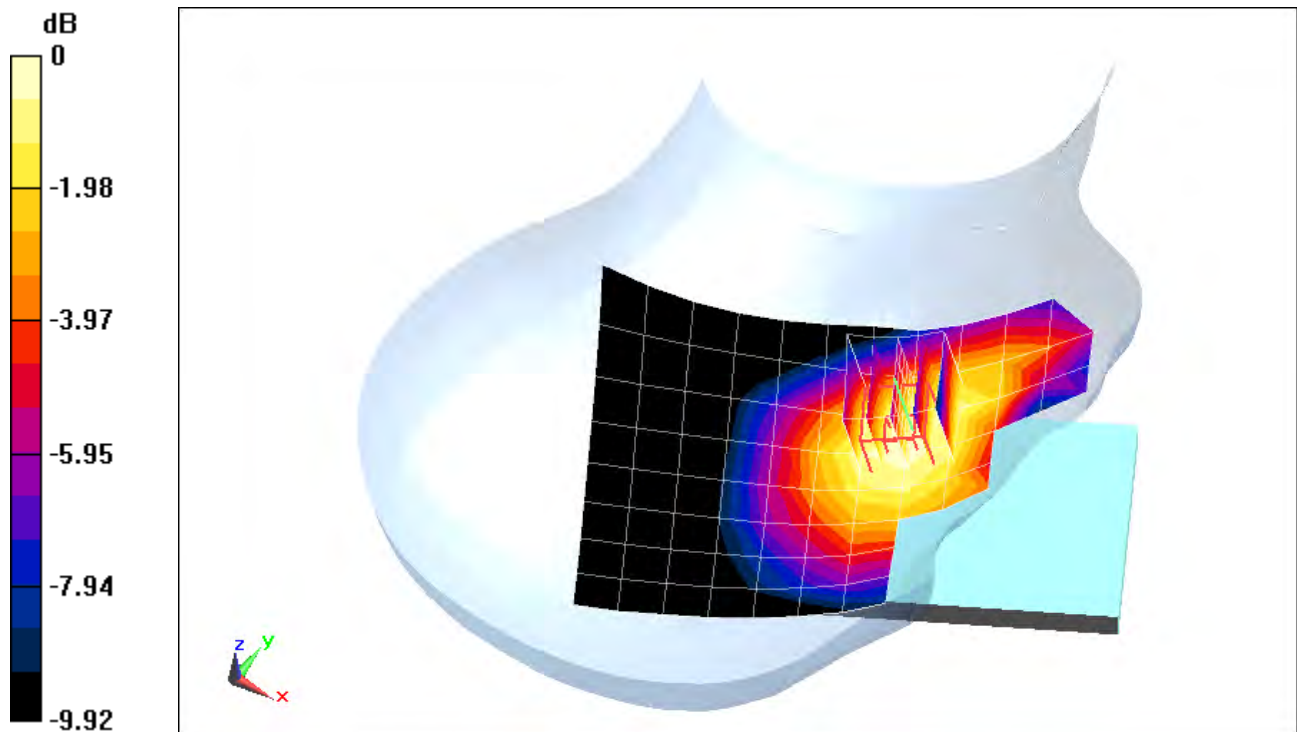

0 dB = 0.125 W/kg = -9.03 dBW/kg

PCTEST ENGINEERING LABORATORY, INC.

DUT: A3LSMN915G; Type: Portable Handset; Serial: F227C

Communication System: UID 0, WCDMA1900; Frequency: 1880 MHz; Duty Cycle: 1:1

Medium: 1900 Head Medium parameters used:

$$f = 1880 \text{ MHz}; \sigma = 1.388 \text{ S/m}; \epsilon_r = 41.1; \rho = 1000 \text{ kg/m}^3$$

Phantom section: Right Section

Test Date: 08-14-2014; Ambient Temp: 21.8°C; Tissue Temp: 20.4°C

Probe: ES3DV3 - SN3213; ConvF(4.99, 4.99, 4.99); Calibrated: 4/11/2014;

Sensor-Surface: 3mm (Mechanical Surface Detection)

Electronics: DAE4 Sn1364; Calibrated: 3/17/2014

Phantom: SAM Main; Type: SAM 4.0; Serial: TP-1406

Measurement SW: DASY4, Version 4.7 (80); SEMCAD X Version 14.6.10 (7331)

Mode: UMTS 1900, Right Head, Cheek, Mid.ch

Area Scan (9x14x1): Measurement grid: dx=15mm, dy=15mm

Zoom Scan (5x5x7)/Cube 0: Measurement grid: dx=8mm, dy=8mm, dz=5mm

Reference Value = 12.62 V/m; Power Drift = 0.20 dB

Peak SAR (extrapolated) = 0.482 W/kg

SAR(1 g) = 0.232 W/kg

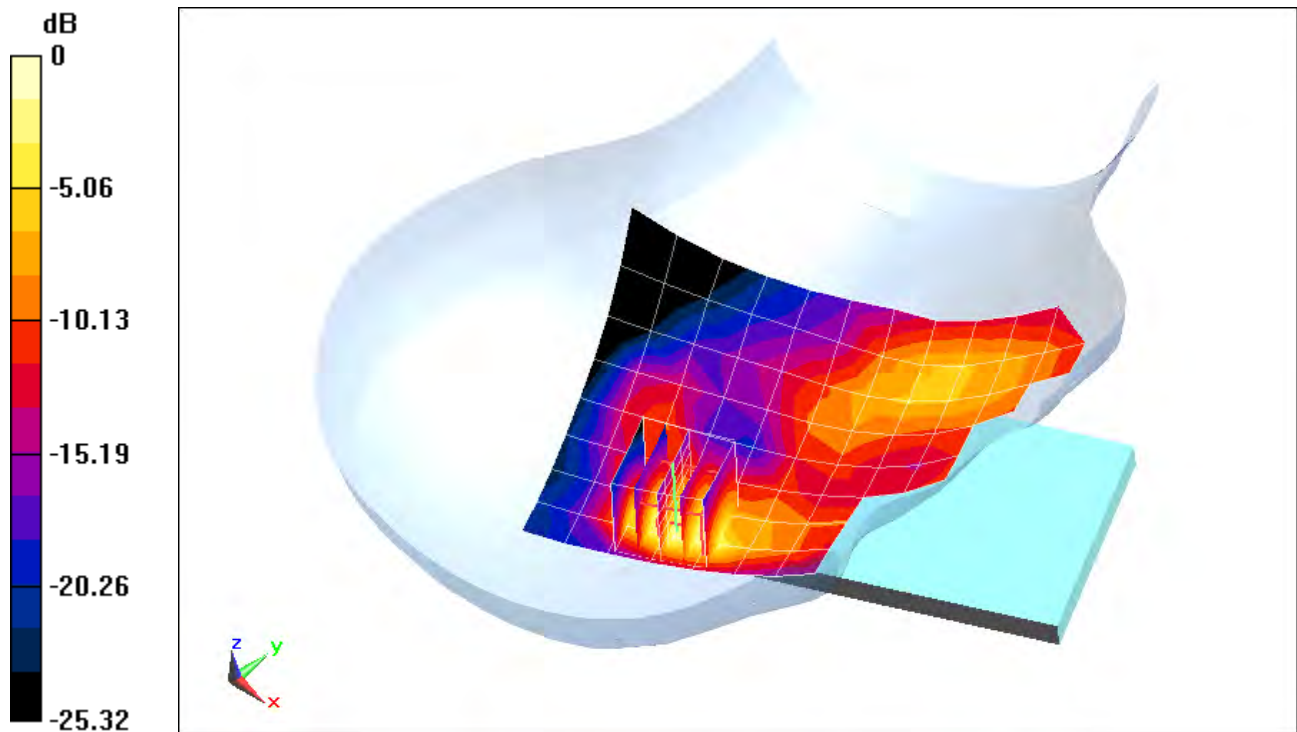

PCTEST ENGINEERING LABORATORY, INC.

DUT: A3LSMN915G; Type: Portable Handset; Serial: F238A

Communication System: UID 0, LTE BAND 5; Frequency: 836.5 MHz; Duty Cycle: 1:1

Medium: 835 Head Medium parameters used (interpolated):

$f = 836.5 \text{ MHz}$; $\sigma = 0.924 \text{ S/m}$; $\epsilon_r = 41.921$; $\rho = 1000 \text{ kg/m}^3$

Phantom section: Right Section

Test Date: 08-18-2014; Ambient Temp: 23.7°C; Tissue Temp: 20.0°C

Probe: ES3DV3 - SN3213; ConvF(6.37, 6.37, 6.37); Calibrated: 4/11/2014;

Sensor-Surface: 3mm (Mechanical Surface Detection)

Electronics: DAE4 Sn1364; Calibrated: 3/17/2014

Phantom: SAM Sub; Type: SAM 4.0; Serial: TP-1357

Measurement SW: DASY4, Version 4.7 (80); SEMCAD X Version 14.6.10 (7331)

Mode: LTE Band 5 (Cell), Right Head, Cheek, Mid.ch

10 MHz Bandwidth, QPSK, 25 RB, 0 RB Offset

Area Scan (9x14x1): Measurement grid: dx=15mm, dy=15mm

Zoom Scan (5x5x7)/Cube 0: Measurement grid: dx=8mm, dy=8mm, dz=5mm

Reference Value = 9.567 V/m; Power Drift = -0.14 dB

Peak SAR (extrapolated) = 0.102 W/kg

SAR(1 g) = 0.079 W/kg

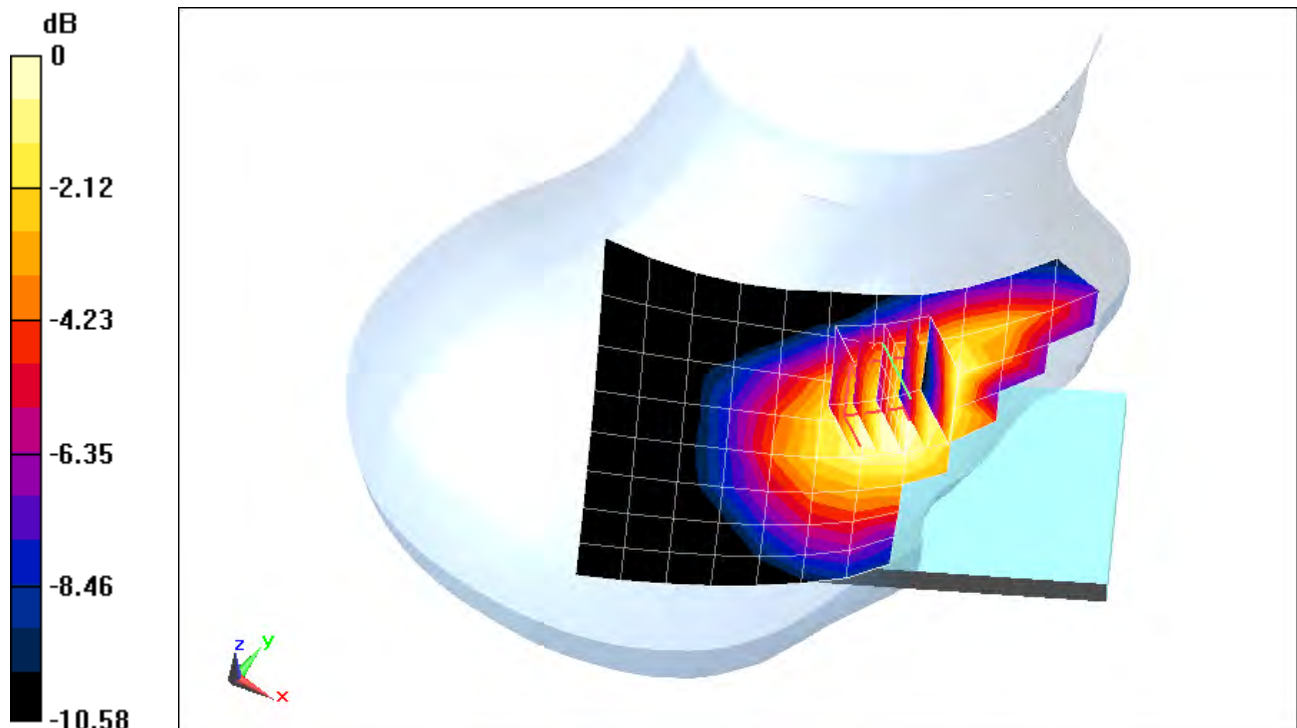

0 dB = 0.0859 W/kg = -10.66 dBW/kg

PCTEST ENGINEERING LABORATORY, INC.

DUT: A3LSMN915G; Type: Portable Handset; Serial: F238A

Communication System: UID 0, LTE Band 4 (AWS) (0); Frequency: 1732.5 MHz; Duty Cycle: 1:1

Medium: 1750 Head Medium parameters used (interpolated):

$f = 1732.5 \text{ MHz}$; $\sigma = 1.339 \text{ S/m}$; $\epsilon_r = 39.099$; $\rho = 1000 \text{ kg/m}^3$

Phantom section: Left Section

Test Date: 08-18-2014; Ambient Temp: 24.8°C; Tissue Temp: 23.0°C

Probe: ES3DV3 - SN3263; ConvF(5.41, 5.41, 5.41); Calibrated: 5/15/2014;

Sensor-Surface: 3mm (Mechanical Surface Detection)

Electronics: DAE4 Sn859; Calibrated: 5/14/2014

Phantom: SAM v5.0 Left; Type: QD000P40CD; Serial: TP: 1687

Measurement SW: DASY52, Version 52.8 (8); SEMCAD X Version 14.6.10 (7331)

Mode: LTE Band 4 (AWS), Left Head, Cheek, Mid.ch

QPSK, 20 MHz Bandwidth, 1 RB, 99 RB Offset

Area Scan (9x14x1): Measurement grid: dx=15mm, dy=15mm

Zoom Scan (5x5x7)/Cube 0: Measurement grid: dx=8mm, dy=8mm, dz=5mm

Reference Value = 8.929 V/m; Power Drift = 0.08 dB

Peak SAR (extrapolated) = 0.137 W/kg

SAR(1 g) = 0.085 W/kg

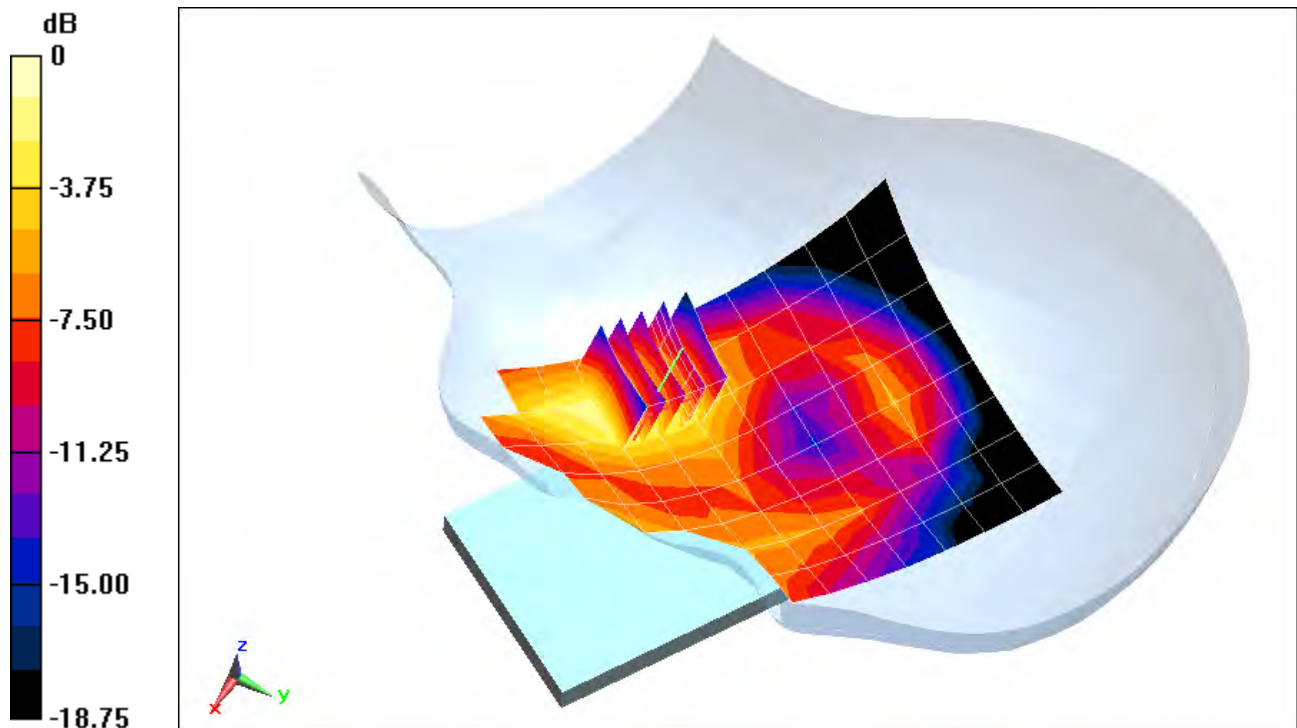

0 dB = 0.106 W/kg = -9.75 dBW/kg

PCTEST ENGINEERING LABORATORY, INC.

DUT: A3LSMN915G; Type: Portable Handset; Serial: F227C

Communication System: UID 0, LTE PCS20 Mhz; Frequency: 1860 MHz; Duty Cycle: 1:1

Medium: 1900 Head Medium parameters used (interpolated):

$$f = 1860 \text{ MHz}; \sigma = 1.37 \text{ S/m}; \epsilon_r = 41.225; \rho = 1000 \text{ kg/m}^3$$

Phantom section: Right Section

Test Date: 08-14-2014; Ambient Temp: 21.8°C; Tissue Temp: 20.4°C

Probe: ES3DV3 - SN3213; ConvF(4.99, 4.99, 4.99); Calibrated: 4/11/2014;

Sensor-Surface: 3mm (Mechanical Surface Detection)

Electronics: DAE4 Sn1364; Calibrated: 3/17/2014

Phantom: SAM Main; Type: SAM 4.0; Serial: TP-1406

Measurement SW: DASY4, Version 4.7 (80); SEMCAD X Version 14.6.10 (7331)

Mode: LTE Band 2 (PCS), Right Head, Cheek, Low.ch
20 MHz Bandwidth, QPSK, 1 RB, 0 RB Offset

Area Scan (9x14x1): Measurement grid: dx=15mm, dy=15mm

Zoom Scan (5x5x7)/Cube 0: Measurement grid: dx=8mm, dy=8mm, dz=5mm

Reference Value = 10.18 V/m; Power Drift = 0.00 dB

Peak SAR (extrapolated) = 0.386 W/kg

SAR(1 g) = 0.197 W/kg

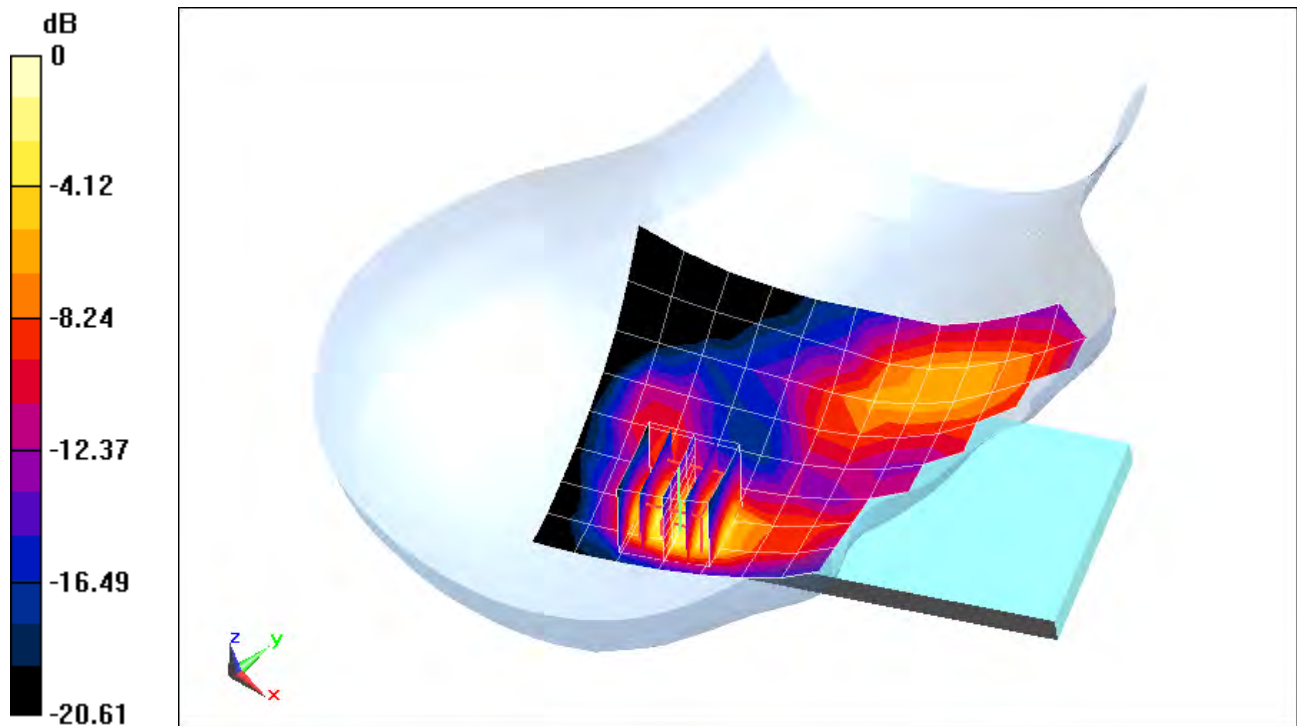

0 dB = 0.263 W/kg = -5.80 dBW/kg

PCTEST ENGINEERING LABORATORY, INC.

DUT: A3LSMN915G; Type: Portable Handset; Serial: F2279

Communication System: UID 0, IEEE 802.11b; Frequency: 2412 MHz; Duty Cycle: 1:1

Medium: 2450 Head Medium parameters used (interpolated):

$f = 2412 \text{ MHz}$; $\sigma = 1.751 \text{ S/m}$; $\epsilon_r = 40.707$; $\rho = 1000 \text{ kg/m}^3$

Phantom section: Right Section

Test Date: 08-18-2014; Ambient Temp: 24.5°C; Tissue Temp: 22.0°C

Probe: ES3DV3 - SN3319; ConvF(4.45, 4.45, 4.45); Calibrated: 4/17/2014;

Sensor-Surface: 3mm (Mechanical Surface Detection)

Electronics: DAE4 Sn1368; Calibrated: 4/11/2014

Phantom: SAM; Type: QD000P40CD; Serial: TP:1758

Measurement SW: DASY52, Version 52.8 (8); SEMCAD X Version 14.6.10 (7331)

Mode: IEEE 802.11b, Antenna 2, Right Head, Cheek, Ch 01, 1 Mbps

Area Scan (11x17x1): Measurement grid: dx=12mm, dy=12mm

Zoom Scan (7x7x7)/Cube 0: Measurement grid: dx=5mm, dy=5mm, dz=5mm

Reference Value = 11.56 V/m; Power Drift = 0.06 dB

Peak SAR (extrapolated) = 0.474 W/kg

SAR(1 g) = 0.197 W/kg

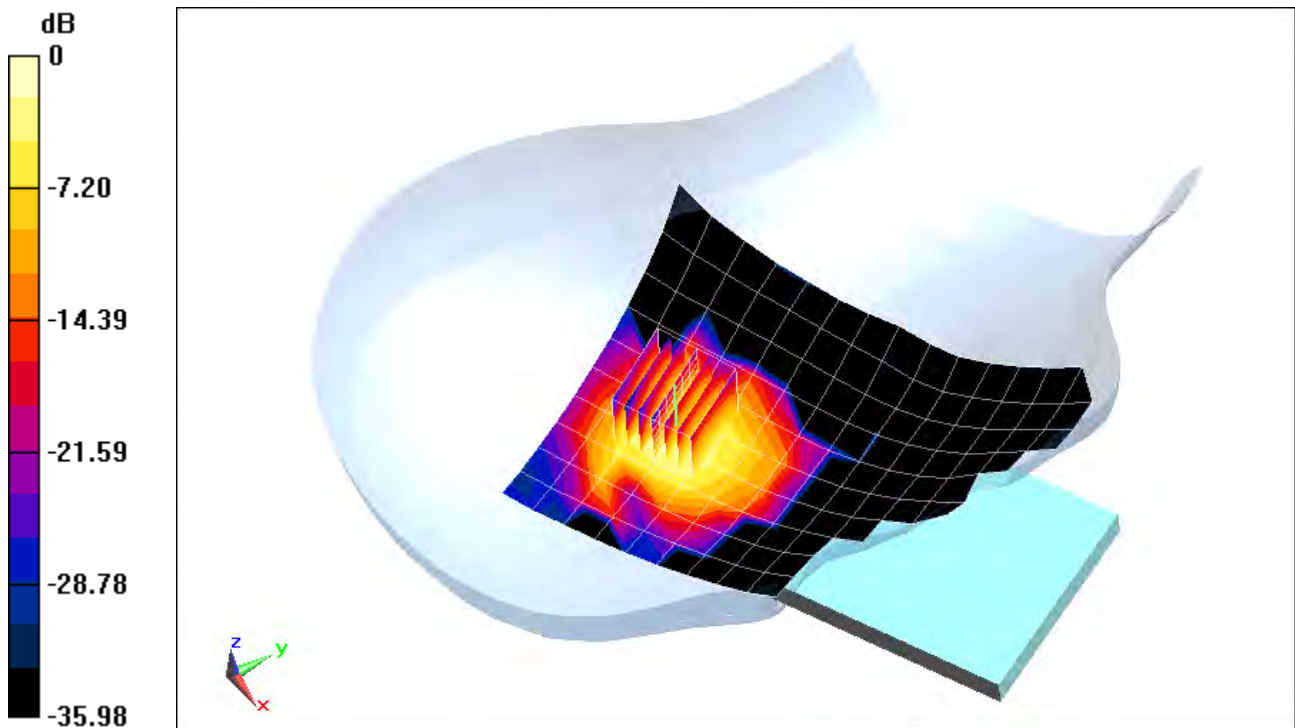

0 dB = 0.260 W/kg = -5.85 dBW/kg

PCTEST ENGINEERING LABORATORY, INC.

DUT: A3LSMN915G; Type: Portable Handset; Serial: F238A

Communication System: UID 0, IEEE 802.11a (0); Frequency: 5825 MHz; Duty Cycle: 1:1

Medium: 5 GHz Head Medium parameters used:

$f = 5825 \text{ MHz}$; $\sigma = 5.21 \text{ S/m}$; $\epsilon_r = 36.244$; $\rho = 1000 \text{ kg/m}^3$

Phantom section: Right Section

Test Date: 08-14-2014; Ambient Temp: 24.3°C; Tissue Temp: 23.6°C

Probe: EX3DV4 - SN3914; ConvF(4.52, 4.52, 4.52); Calibrated: 10/23/2013;

Sensor-Surface: 1.4mm (Mechanical Surface Detection)

Electronics: DAE4 Sn1333; Calibrated: 11/19/2013

Phantom: SAM V5.0 Right; Type: QD000P40CD; Serial: 1647

Measurement SW: DASY52, Version 52.8 (8); SEMCAD X Version 14.6.10 (7331)

Mode: IEEE 802.11a, Antenna 2, 5.8 GHz, Right Head, Cheek, Ch 165, 6 Mbps

Area Scan (13x22x1): Measurement grid: dx=10mm, dy=10mm

Zoom Scan (7x7x7)/Cube 0: Measurement grid: dx=4mm, dy=4mm, dz=1.4mm; Graded Ratio: 1.4

Reference Value = 4.050 V/m; Power Drift = 0.174 dB

Peak SAR (extrapolated) = 0.503 W/kg

SAR(1 g) = 0.083 W/kg

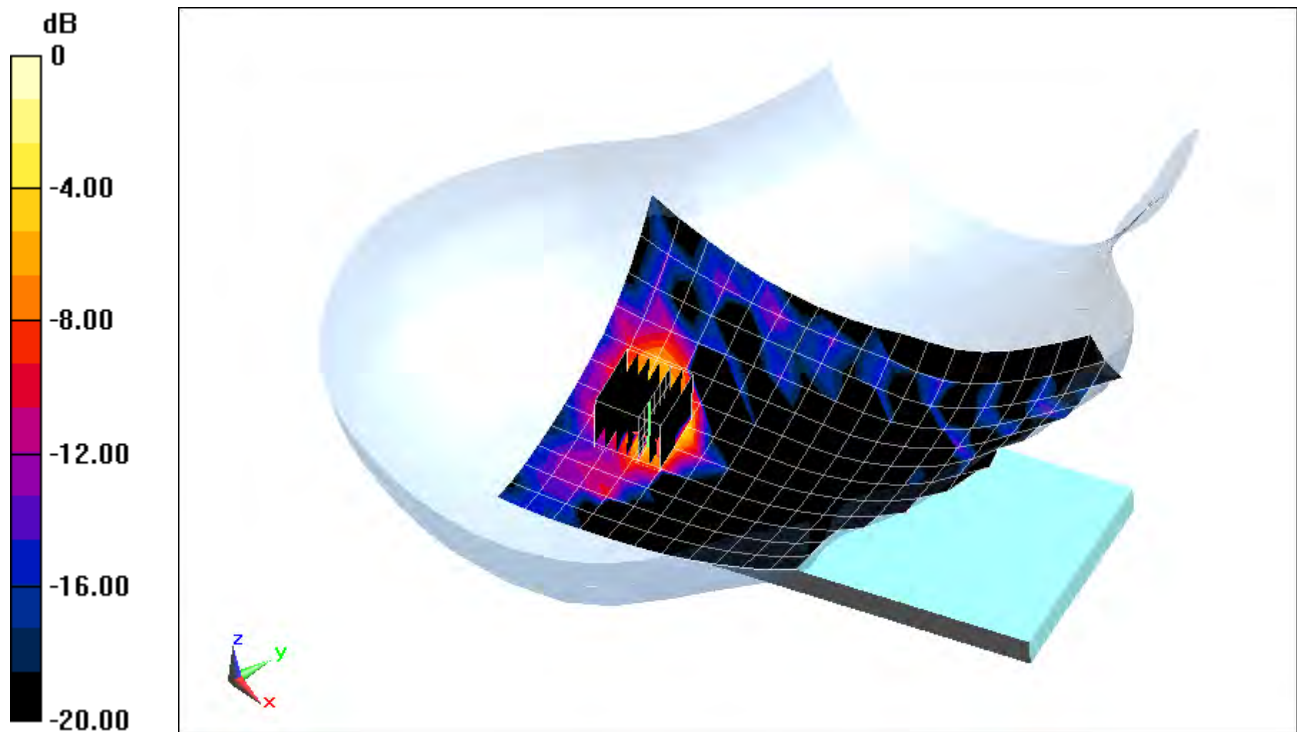

PCTEST ENGINEERING LABORATORY, INC.

DUT: A3LSMN915G; Type: Portable Handset; Serial: F238A

Communication System: UID 0, IEEE 802.11a (0); Frequency: 5700 MHz; Duty Cycle: 1:1

Medium: 5 GHz Head Medium parameters used:

$$f = 5700 \text{ MHz}; \sigma = 5.082 \text{ S/m}; \epsilon_r = 36.438; \rho = 1000 \text{ kg/m}^3$$

Phantom section: Right Section

Test Date: 08-14-2014; Ambient Temp: 24.2°C; Tissue Temp: 23.8°C

Probe: EX3DV4 - SN3914; ConvF(4.37, 4.37, 4.37); Calibrated: 10/23/2013;

Sensor-Surface: 1.4mm (Mechanical Surface Detection)

Electronics: DAE4 Sn1333; Calibrated: 11/19/2013

Phantom: SAM V5.0 Right; Type: QD000P40CD; Serial: 1647

Measurement SW: DASY52, Version 52.8 (8); SEMCAD X Version 14.6.10 (7331)

Mode: IEEE 802.11a, 5.5 GHz, Antenna 2, Right Head, Cheek, Ch 140, 6 Mbps

Area Scan (13x22x1): Measurement grid: dx=10mm, dy=10mm

Zoom Scan (7x7x7)/Cube 0: Measurement grid: dx=4mm, dy=4mm, dz=1.4mm; Graded Ratio:1.4

Reference Value = 4.558 V/m; Power Drift = 0.11 dB

Peak SAR (extrapolated) = 0.571 W/kg

SAR(1 g) = 0.098 W/kg

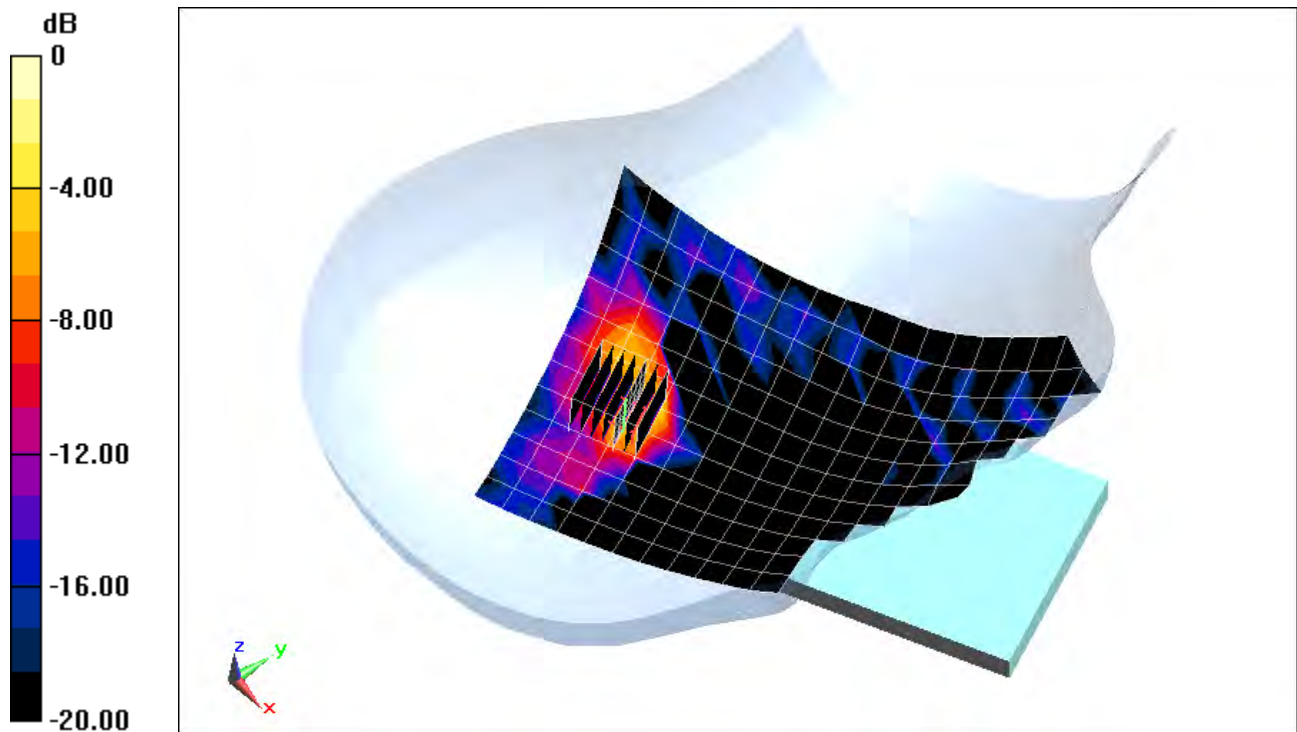

0 dB = 0.349 W/kg = -4.57 dBW/kg

PCTEST ENGINEERING LABORATORY, INC.

DUT: A3LSMN915G; Type: Portable Handset; Serial: F238A

Communication System: UID 0, GSM (0); Frequency: 836.6 MHz; Duty Cycle: 1:8.3

Medium: 835 Body Medium parameters used (interpolated):

$f = 836.6 \text{ MHz}$; $\sigma = 0.998 \text{ S/m}$; $\epsilon_r = 52.996$; $\rho = 1000 \text{ kg/m}^3$

Phantom section: Flat Section; Space: 1.0 cm

Test Date: 08-14-2014; Ambient Temp: 23.9°C; Tissue Temp: 23.1°C

Probe: ES3DV3 - SN3263; ConvF(6.16, 6.16, 6.16); Calibrated: 5/15/2014;

Sensor-Surface: 3mm (Mechanical Surface Detection)

Electronics: DAE4 Sn859; Calibrated: 5/14/2014

Phantom: SAM v5.0 front; Type: QD000P40CD; Serial: TP-1646

Measurement SW: DASY52, Version 52.8 (8);SEMCAD X Version 14.6.10 (7331)

Mode: GSM 850, Body SAR, Back side, Mid.ch

Area Scan (9x14x1): Measurement grid: dx=15mm, dy=15mm

Zoom Scan (6x6x7)/Cube 0: Measurement grid: dx=8mm, dy=8mm, dz=5mm

Reference Value = 15.54 V/m; Power Drift = 0.02 dB

Peak SAR (extrapolated) = 0.336 W/kg

SAR(1 g) = 0.237 W/kg

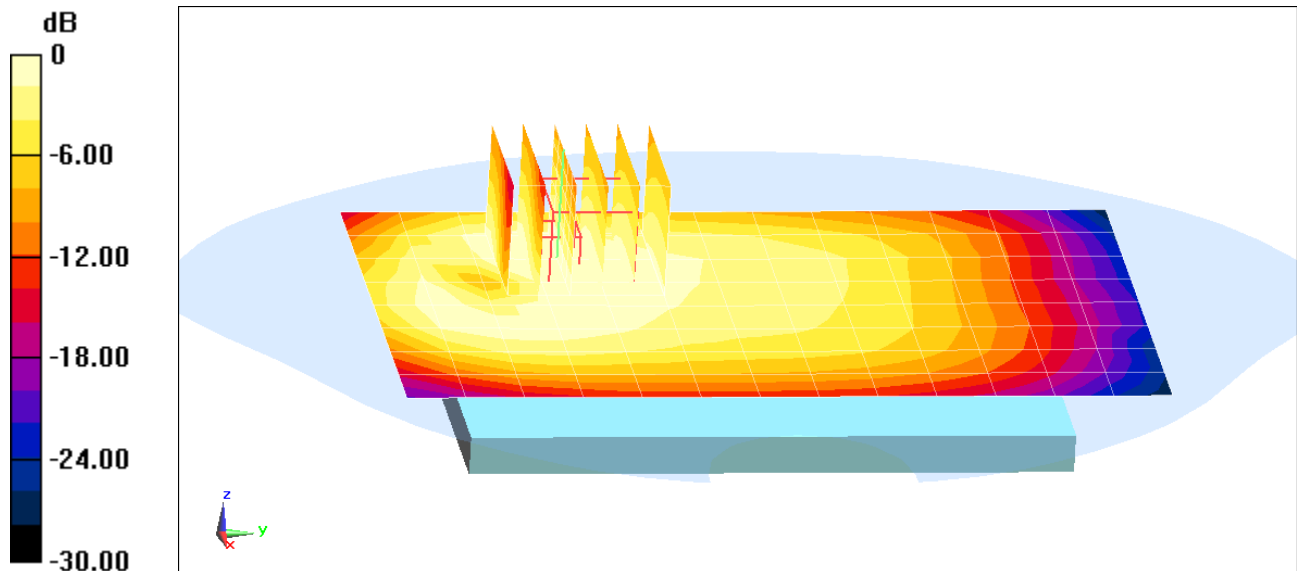

0 dB = 0.268 W/kg = -5.72 dBW/kg

PCTEST ENGINEERING LABORATORY, INC.

DUT: A3LSMN915G; Type: Portable Handset; Serial: F238A

Communication System: UID 0, GSM GPRS; 4 Tx slots (0); Frequency: 836.6 MHz; Duty Cycle: 1:2.076

Medium: 835 Body Medium parameters used (interpolated):

$f = 836.6 \text{ MHz}$; $\sigma = 0.998 \text{ S/m}$; $\epsilon_r = 52.996$; $\rho = 1000 \text{ kg/m}^3$

Phantom section: Flat Section; Space: 1.0 cm

Test Date: 08-14-2014; Ambient Temp: 23.9°C; Tissue Temp: 23.1°C

Probe: ES3DV3 - SN3263; ConvF(6.16, 6.16, 6.16); Calibrated: 5/15/2014;

Sensor-Surface: 3mm (Mechanical Surface Detection)

Electronics: DAE4 Sn859; Calibrated: 5/14/2014

Phantom: SAM v5.0 front; Type: QD000P40CD; Serial: TP-1646

Measurement SW: DASY52, Version 52.8 (8);SEMCAD X Version 14.6.10 (7331)

Mode: GPRS 850, Body SAR, Front side, Mid.ch, 4 Tx Slots

Area Scan (9x14x1): Measurement grid: dx=15mm, dy=15mm

Zoom Scan (5x5x7)/Cube 0: Measurement grid: dx=8mm, dy=8mm, dz=5mm

Reference Value = 16.16 V/m; Power Drift = 0.05 dB

Peak SAR (extrapolated) = 0.384 W/kg

SAR(1 g) = 0.256 W/kg

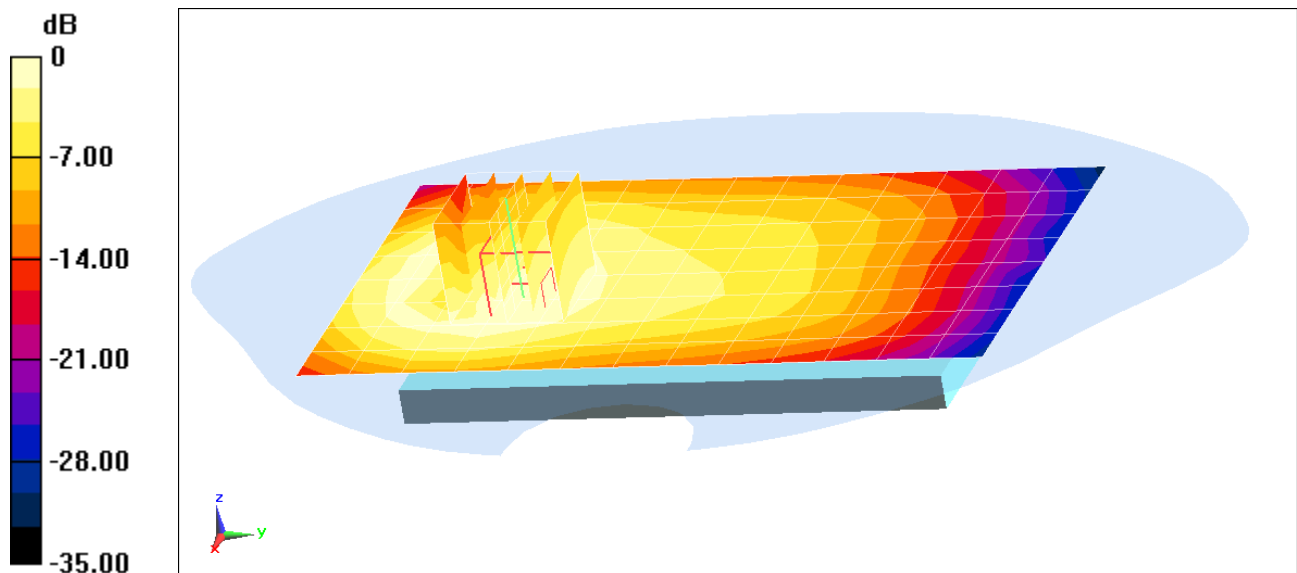

0 dB = 0.296 W/kg = -5.29 dBW/kg

PCTEST ENGINEERING LABORATORY, INC.

DUT: A3LSMN915G; Type: Portable Handset; Serial: F238A

Communication System: UID 0, GSM; Frequency: 1880 MHz; Duty Cycle: 1:8.3

Medium: 1900 Body Medium parameters used:

$$f = 1880 \text{ MHz}; \sigma = 1.489 \text{ S/m}; \epsilon_r = 51.908; \rho = 1000 \text{ kg/m}^3$$

Phantom section: Flat Section; Space: 1.0 cm

Test Date: 08-14-2014; Ambient Temp: 24.2°C; Tissue Temp: 22.3°C

Probe: ES3DV3 - SN3287; ConvF(4.67, 4.67, 4.67); Calibrated: 11/20/2013;

Sensor-Surface: 3mm (Mechanical Surface Detection)

Electronics: DAE4 Sn1408; Calibrated: 11/19/2013

Phantom: ELI v5.0; Type: QDOVA001BB; Serial: 1229

Measurement SW: DASY52, Version 52.8 (8); SEMCAD X Version 14.6.10 (7331)

Mode: GSM 1900, Body SAR, Back side, Mid.ch

Area Scan (9x15x1): Measurement grid: dx=15mm, dy=15mm

Zoom Scan (5x5x7)/Cube 0: Measurement grid: dx=8mm, dy=8mm, dz=5mm

Reference Value = 11.74 V/m; Power Drift = 0.11 dB

Peak SAR (extrapolated) = 0.305 W/kg

SAR(1 g) = 0.189 W/kg

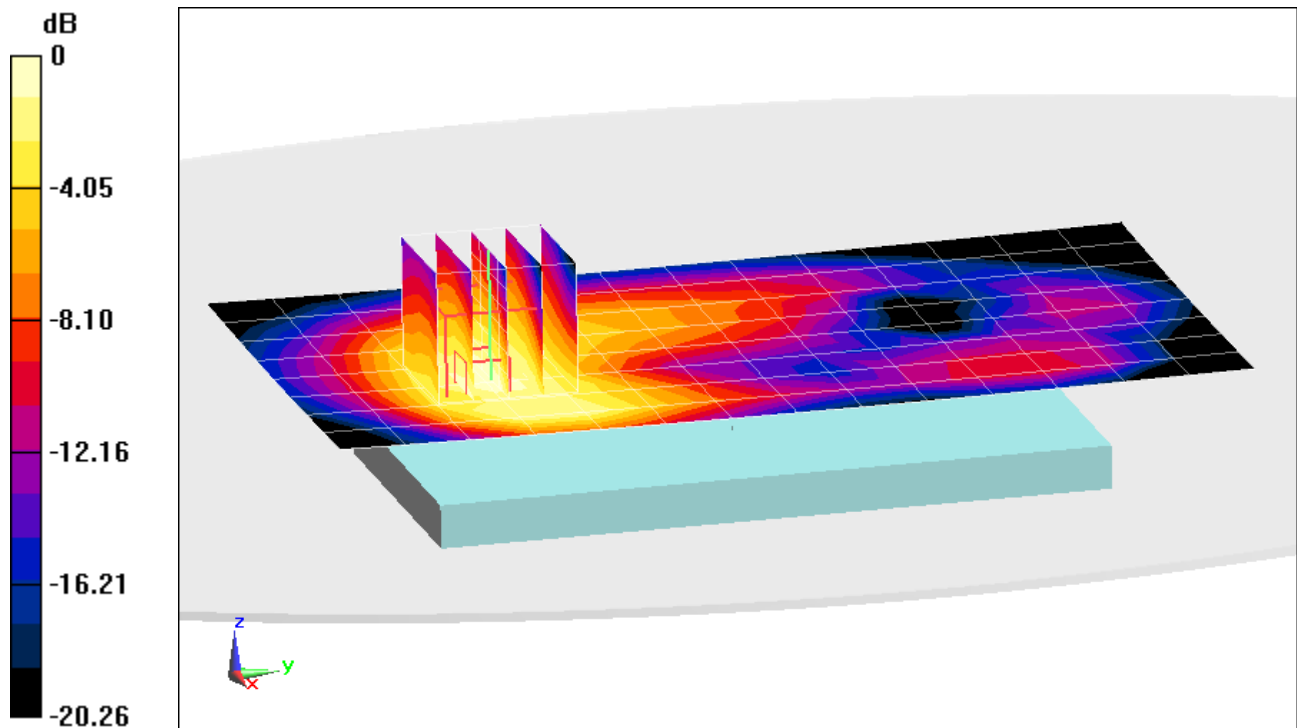

0 dB = 0.216 W/kg = -6.66 dBW/kg

PCTEST ENGINEERING LABORATORY, INC.

DUT: A3LSMN915G; Type: Portable Handset; Serial: F238A

Communication System: UID 0, GSM GPRS; 3 Tx slots (0); Frequency: 1880 MHz; Duty Cycle: 1:2.76

Medium: 1900 Body Medium parameters used:

$$f = 1880 \text{ MHz}; \sigma = 1.489 \text{ S/m}; \epsilon_r = 51.908; \rho = 1000 \text{ kg/m}^3$$

Phantom section: Flat Section; Space: 1.0 cm

Test Date: 08-14-2014; Ambient Temp: 24.2°C; Tissue Temp: 22.3°C

Probe: ES3DV3 - SN3287; ConvF(4.67, 4.67, 4.67); Calibrated: 11/20/2013;

Sensor-Surface: 3mm (Mechanical Surface Detection)

Electronics: DAE4 Sn1408; Calibrated: 11/19/2013

Phantom: ELI v5.0; Type: QDOVA001BB; Serial: 1229

Measurement SW: DASY52, Version 52.8 (8); SEMCAD X Version 14.6.10 (7331)

Mode: GPRS 1900, Body SAR, Bottom Edge, Mid.ch, 3 Tx Slots

Area Scan (10x7x1): Measurement grid: dx=5mm, dy=15mm

Zoom Scan (5x5x7)/Cube 0: Measurement grid: dx=8mm, dy=8mm, dz=5mm

Reference Value = 19.81 V/m; Power Drift = -0.06 dB

Peak SAR (extrapolated) = 0.833 W/kg

SAR(1 g) = 0.529 W/kg

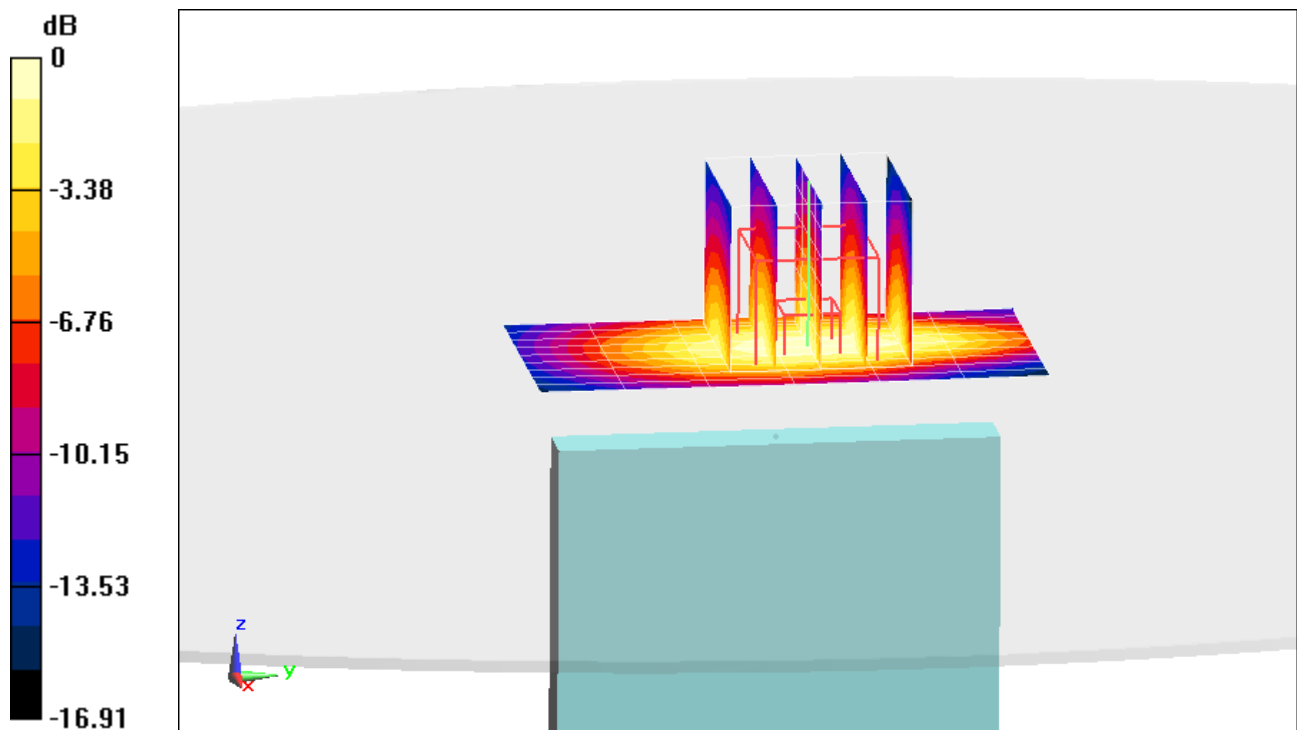

PCTEST ENGINEERING LABORATORY, INC.

DUT: A3LSMN915G; Type: Portable Handset; Serial: F227C

Communication System: UID 0, UMTS; Frequency: 836.6 MHz; Duty Cycle: 1:1

Medium: 835 Body Medium parameters used (interpolated):

$f = 836.6 \text{ MHz}$; $\sigma = 0.998 \text{ S/m}$; $\epsilon_r = 52.996$; $\rho = 1000 \text{ kg/m}^3$

Phantom section: Flat Section; Space: 1.0 cm

Test Date: 08-14-2014; Ambient Temp: 23.9°C; Tissue Temp: 23.1°C

Probe: ES3DV3 - SN3263; ConvF(6.16, 6.16, 6.16); Calibrated: 5/15/2014;

Sensor-Surface: 3mm (Mechanical Surface Detection)

Electronics: DAE4 Sn859; Calibrated: 5/14/2014

Phantom: SAM v5.0 front; Type: QD000P40CD; Serial: TP-1646

Measurement SW: DASY52, Version 52.8 (8);SEMCAD X Version 14.6.10 (7331)

Mode: UMTS 850, Body SAR, Back side, Mid.ch

Area Scan (9x14x1): Measurement grid: dx=15mm, dy=15mm

Zoom Scan (6x6x7)/Cube 0: Measurement grid: dx=8mm, dy=8mm, dz=5mm

Reference Value = 18.26 V/m; Power Drift = 0.07 dB

Peak SAR (extrapolated) = 0.466 W/kg

SAR(1 g) = 0.324 W/kg

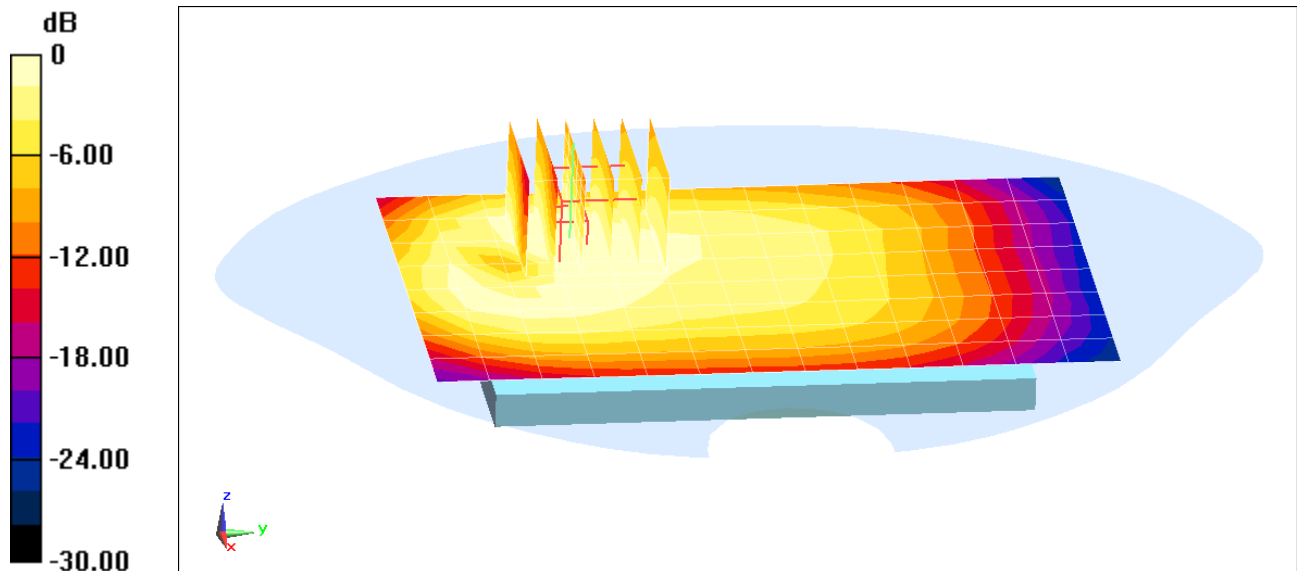

0 dB = 0.367 W/kg = -4.35 dBW/kg

PCTEST ENGINEERING LABORATORY, INC.

DUT: A3LSMN915G; Type: Portable Handset; Serial: F227C

Communication System: UID 0, UMTS; Frequency: 836.6 MHz; Duty Cycle: 1:1

Medium: 835 Body Medium parameters used (interpolated):

$f = 836.6 \text{ MHz}$; $\sigma = 0.998 \text{ S/m}$; $\epsilon_r = 52.996$; $\rho = 1000 \text{ kg/m}^3$

Phantom section: Flat Section; Space: 1.0 cm

Test Date: 08-14-2014; Ambient Temp: 23.9°C; Tissue Temp: 23.1°C

Probe: ES3DV3 - SN3263; ConvF(6.16, 6.16, 6.16); Calibrated: 5/15/2014;

Sensor-Surface: 3mm (Mechanical Surface Detection)

Electronics: DAE4 Sn859; Calibrated: 5/14/2014

Phantom: SAM v5.0 front; Type: QD000P40CD; Serial: TP-1646

Measurement SW: DASY52, Version 52.8 (8);SEMCAD X Version 14.6.10 (7331)

Mode: UMTS 850, Body SAR, Front side, Mid.ch

Area Scan (9x14x1): Measurement grid: dx=15mm, dy=15mm

Zoom Scan (5x5x7)/Cube 0: Measurement grid: dx=8mm, dy=8mm, dz=5mm

Reference Value = 19.52 V/m; Power Drift = 0.03 dB

Peak SAR (extrapolated) = 0.533 W/kg

SAR(1 g) = 0.367 W/kg

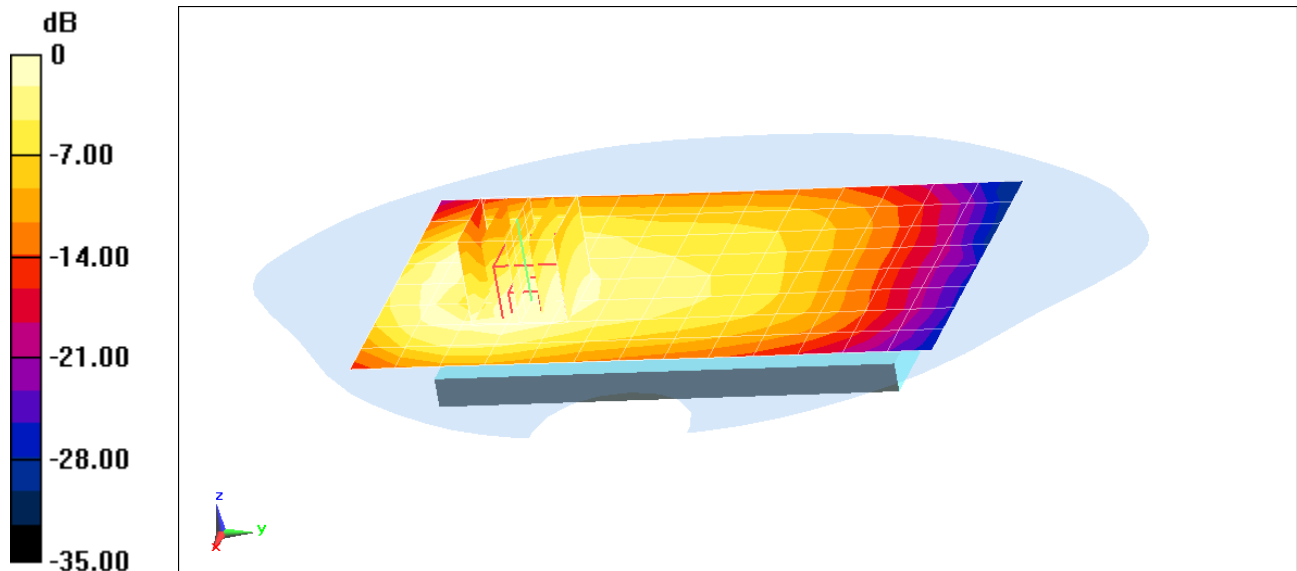

0 dB = 0.418 W/kg = -3.79 dBW/kg

PCTEST ENGINEERING LABORATORY, INC.

DUT: A3LSMN915G; Type: Portable Handset; Serial: F227C

Communication System: UID 0, WCDMA1900; Frequency: 1880 MHz; Duty Cycle: 1:1

Medium: 1900 Body Medium parameters used:

$$f = 1880 \text{ MHz}; \sigma = 1.544 \text{ S/m}; \epsilon_r = 51.756; \rho = 1000 \text{ kg/m}^3$$

Phantom section: Flat Section; Space: 1.0 cm

Test Date: 08-18-2014; Ambient Temp: 23.0°C; Tissue Temp: 22.2°C

Probe: ES3DV3 - SN3288; ConvF(4.82, 4.82, 4.82); Calibrated: 9/23/2013;

Sensor-Surface: 3mm (Mechanical Surface Detection)

Electronics: DAE4 Sn1323; Calibrated: 9/17/2013

Phantom: SAM with CRP; Type: SAM; Serial: TP1375

Measurement SW: DASY4, Version 4.7 (80); SEMCAD X Version 14.6.10 (7331)

Mode: UMTS 1900, Body SAR, Back side, Mid.ch

Area Scan (9x15x1): Measurement grid: dx=15mm, dy=15mm

Zoom Scan (5x5x7)/Cube 0: Measurement grid: dx=8mm, dy=8mm, dz=5mm

Reference Value = 14.03 V/m; Power Drift = 0.02 dB

Peak SAR (extrapolated) = 0.418 W/kg

SAR(1 g) = 0.273 W/kg

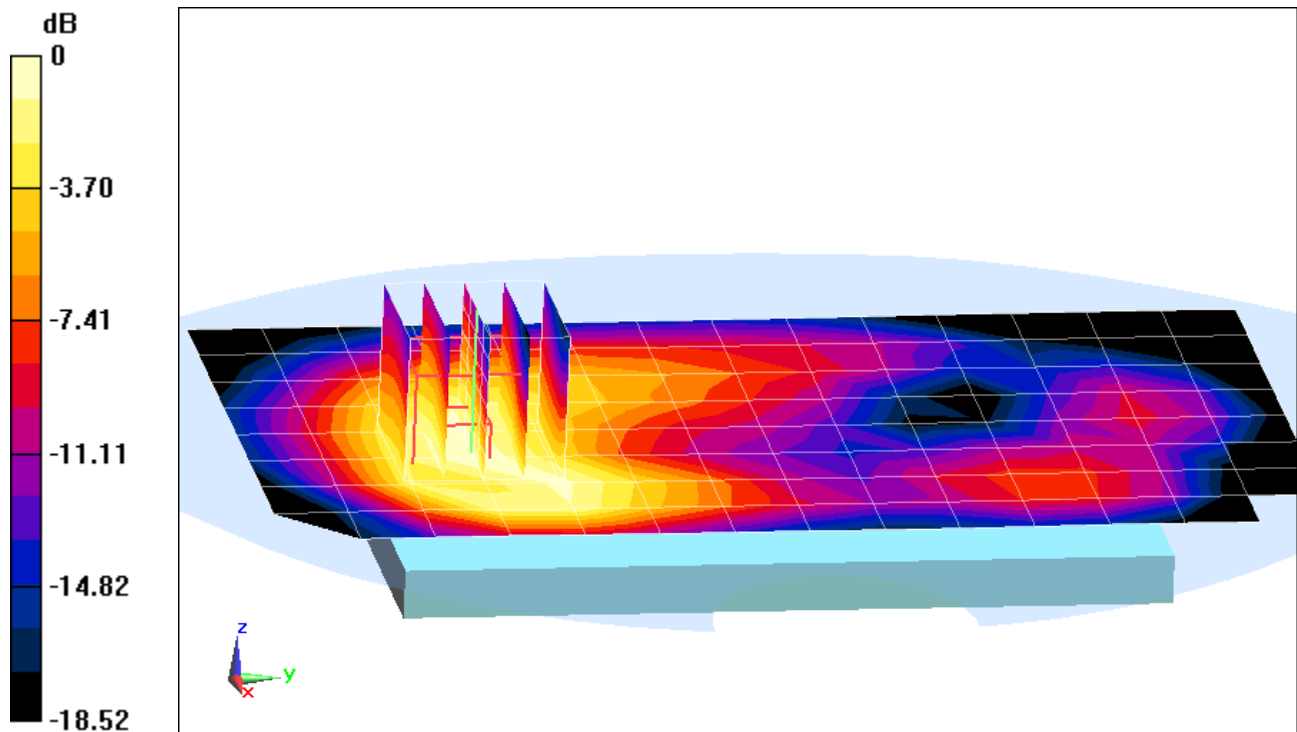

PCTEST ENGINEERING LABORATORY, INC.

DUT: A3LSMN915G; Type: Portable Handset; Serial: F227C

Communication System: UID 0, WCDMA1900; Frequency: 1880 MHz; Duty Cycle: 1:1

Medium: 1900 Body Medium parameters used:

$$f = 1880 \text{ MHz}; \sigma = 1.544 \text{ S/m}; \epsilon_r = 51.756; \rho = 1000 \text{ kg/m}^3$$

Phantom section: Flat Section; Space: 1.0 cm

Test Date: 08-18-2014; Ambient Temp: 23.0°C; Tissue Temp: 22.2°C

Probe: ES3DV3 - SN3288; ConvF(4.82, 4.82, 4.82); Calibrated: 9/23/2013;

Sensor-Surface: 3mm (Mechanical Surface Detection)

Electronics: DAE4 Sn1323; Calibrated: 9/17/2013

Phantom: SAM with CRP; Type: SAM; Serial: TP1375

Measurement SW: DASY4, Version 4.7 (80); SEMCAD X Version 14.6.10 (7331)

Mode: UMTS 1900, Body SAR, Bottom Edge, Mid.ch

Area Scan (9x7x1): Measurement grid: dx=5mm, dy=15mm

Zoom Scan (5x5x7)/Cube 0: Measurement grid: dx=8mm, dy=8mm, dz=5mm

Reference Value = 19.66 V/m; Power Drift = -0.04 dB

Peak SAR (extrapolated) = 0.828 W/kg

SAR(1 g) = 0.523 W/kg

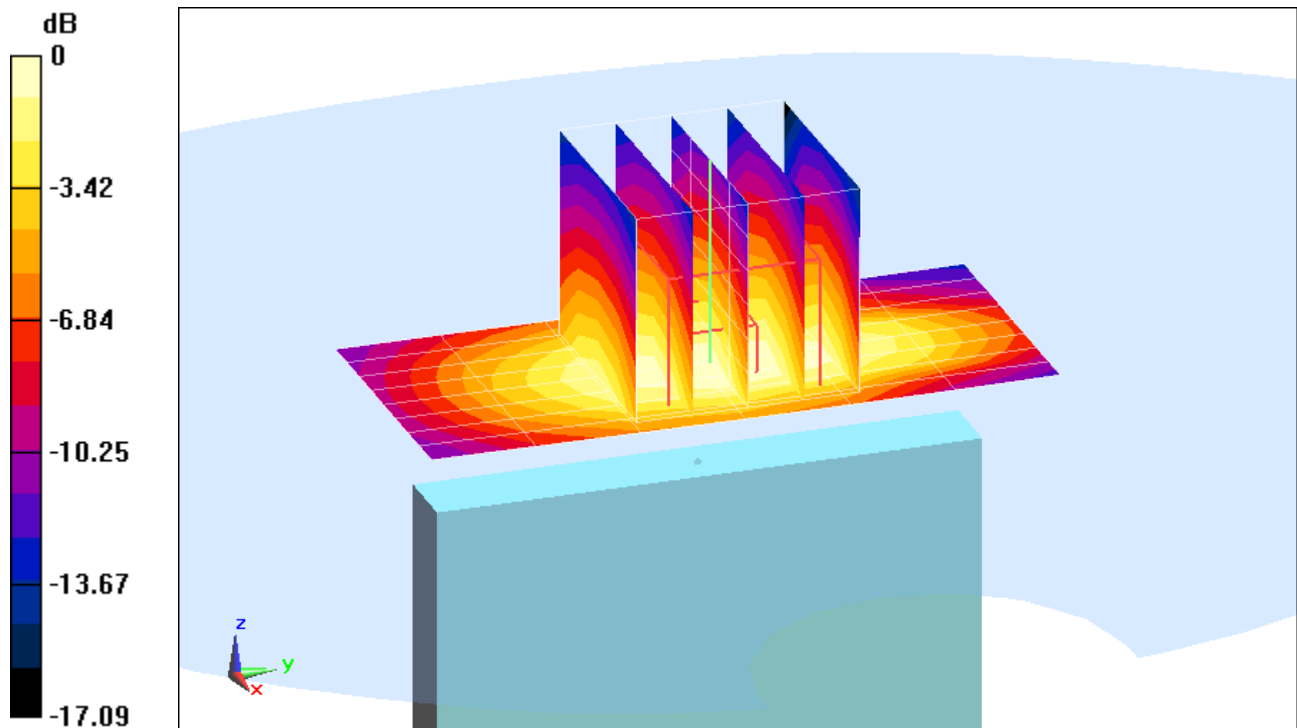

0 dB = 0.631 W/kg = -2.00 dBW/kg

PCTEST ENGINEERING LABORATORY, INC.

DUT: A3LSMN915G; Type: Portable Handset; Serial: F238A

Communication System: UID 0, LTE Band 5; Frequency: 836.5 MHz; Duty Cycle: 1:1

Medium: 835 Body Medium parameters used (interpolated):

$f = 836.5 \text{ MHz}$; $\sigma = 0.998 \text{ S/m}$; $\epsilon_r = 52.997$; $\rho = 1000 \text{ kg/m}^3$

Phantom section: Flat Section; Space: 1.0 cm

Test Date: 08-14-2014; Ambient Temp: 23.9°C; Tissue Temp: 23.1°C

Probe: ES3DV3 - SN3263; ConvF(6.16, 6.16, 6.16); Calibrated: 5/15/2014;

Sensor-Surface: 3mm (Mechanical Surface Detection)

Electronics: DAE4 Sn859; Calibrated: 5/14/2014

Phantom: SAM v5.0 front; Type: QD000P40CD; Serial: TP-1646

Measurement SW: DASY52, Version 52.8 (8);SEMCAD X Version 14.6.10 (7331)

Mode: LTE Band 5 (Cell.), Body SAR, Back side, Mid.ch
10 MHz Bandwidth, QPSK, 1 RB, 0 RB Offset

Area Scan (9x14x1): Measurement grid: dx=15mm, dy=15mm

Zoom Scan (6x6x7)/Cube 0: Measurement grid: dx=8mm, dy=8mm, dz=5mm

Reference Value = 16.53 V/m; Power Drift = 0.05 dB

Peak SAR (extrapolated) = 0.368 W/kg

SAR(1 g) = 0.252 W/kg

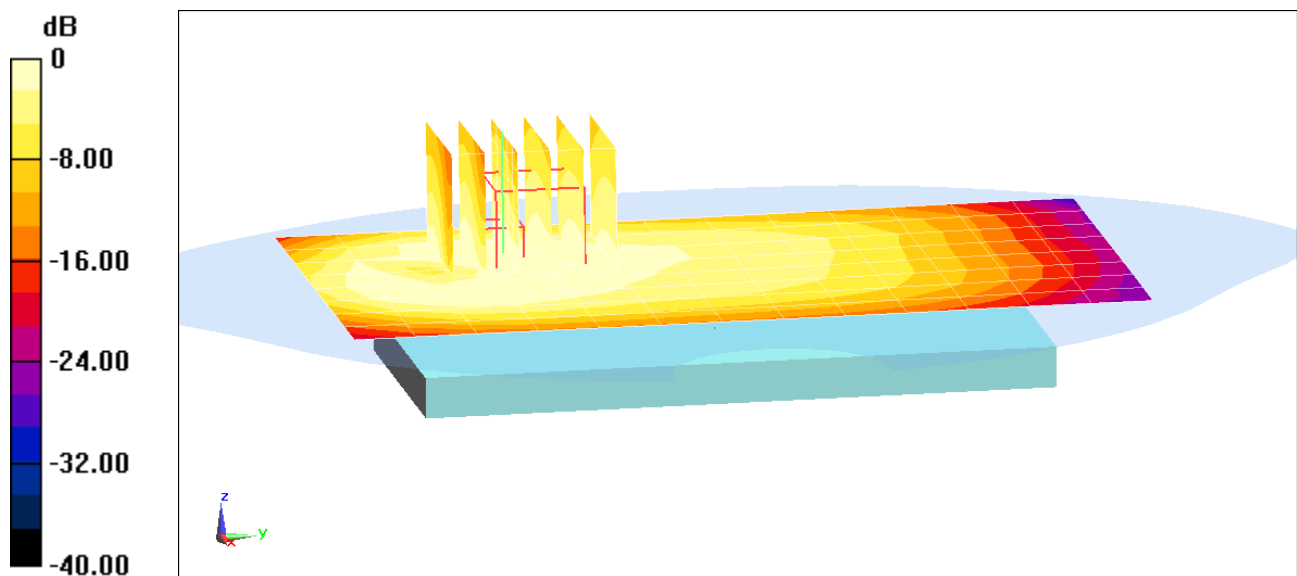

0 dB = 0.287 W/kg = -5.42 dBW/kg

PCTEST ENGINEERING LABORATORY, INC.

DUT: A3LSMN915G; Type: Portable Handset; Serial: F238A

Communication System: UID 0, LTE Band 5 (Cell.); Frequency: 836.5 MHz; Duty Cycle: 1:1

Medium: 835 Body Medium parameters used (interpolated):

$f = 836.5 \text{ MHz}$; $\sigma = 0.998 \text{ S/m}$; $\epsilon_r = 52.997$; $\rho = 1000 \text{ kg/m}^3$

Phantom section: Flat Section; Space: 1.0 cm

Test Date: 08-14-2014; Ambient Temp: 23.9°C; Tissue Temp: 23.1°C

Probe: ES3DV3 - SN3263; ConvF(6.16, 6.16, 6.16); Calibrated: 5/15/2014;

Sensor-Surface: 3mm (Mechanical Surface Detection)

Electronics: DAE4 Sn859; Calibrated: 5/14/2014

Phantom: SAM v5.0 front; Type: QD000P40CD; Serial: TP-1646

Measurement SW: DASY52, Version 52.8 (8); SEMCAD X Version 14.6.10 (7331)

Mode: LTE Band 5 (Cell.), Body SAR, Front side, Mid.ch
10 MHz Bandwidth, QPSK, 1 RB, 0 RB Offset

Area Scan (9x14x1): Measurement grid: dx=15mm, dy=15mm

Zoom Scan (5x5x7)/Cube 0: Measurement grid: dx=8mm, dy=8mm, dz=5mm

Reference Value = 18.76 V/m; Power Drift = -0.01 dB

Peak SAR (extrapolated) = 0.523 W/kg

SAR(1 g) = 0.320 W/kg

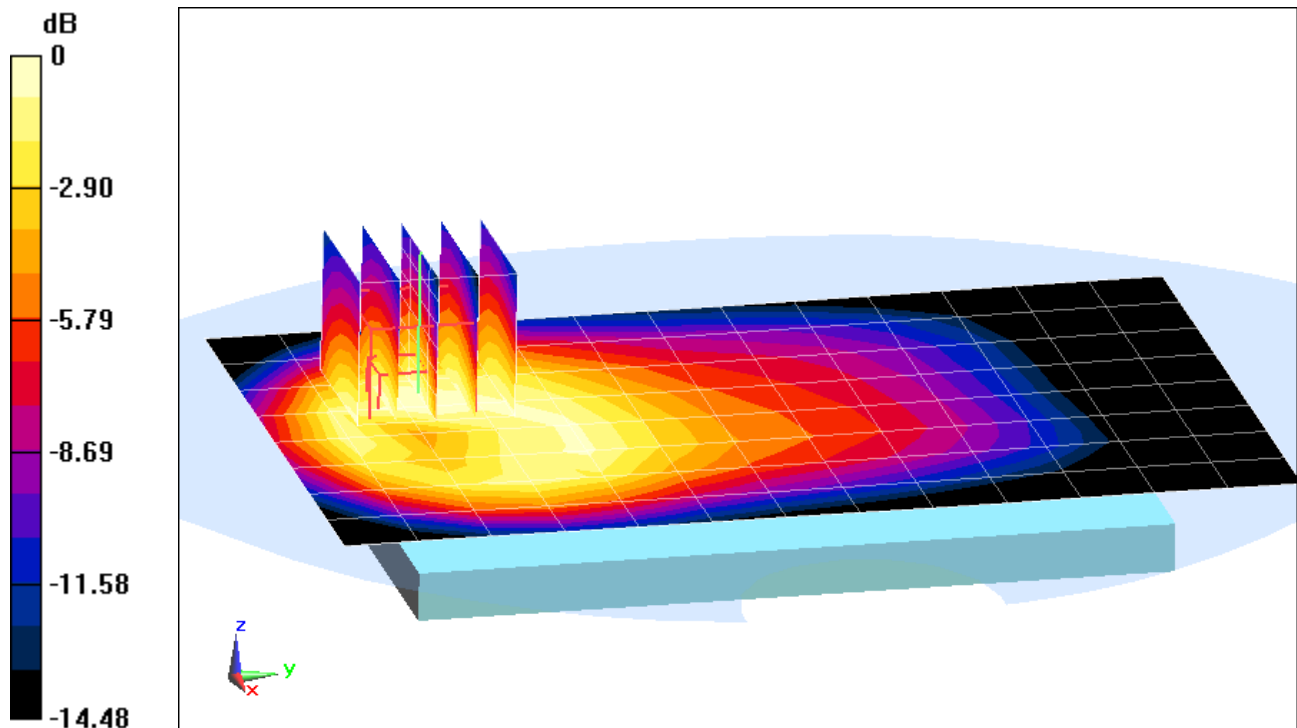

0 dB = 0.376 W/kg = -4.25 dBW/kg

PCTEST ENGINEERING LABORATORY, INC.

DUT: A3LSMN915G; Type: Portable Handset; Serial: F238A

Communication System: UID 0, LTE Band 4 (AWS); Frequency: 1732.5 MHz; Duty Cycle: 1:1

Medium: 1750 Body Medium parameters used (interpolated):

$f = 1732.5 \text{ MHz}$; $\sigma = 1.43 \text{ S/m}$; $\epsilon_r = 52.102$; $\rho = 1000 \text{ kg/m}^3$

Phantom section: Flat Section; Space: 1.0 cm

Test Date: 08-14-2014; Ambient Temp: 23.6°C; Tissue Temp: 23.8°C

Probe: ES3DV3 - SN3332; ConvF(4.93, 4.93, 4.93); Calibrated: 11/25/2013;

Sensor-Surface: 3mm (Mechanical Surface Detection)

Electronics: DAE4 Sn1407; Calibrated: 11/18/2013

Phantom: ELI v5.0; Type: QDOVA001BB; Serial: 1226

Measurement SW: DASY52, Version 52.8 (8); SEMCAD X Version 14.6.10 (7331)

Mode: LTE Band 4 (AWS), Body SAR, Back side, Mid.ch
20 MHz Bandwidth, QPSK, 1 RB, 99 RB Offset

Area Scan (9x15x1): Measurement grid: dx=15mm, dy=15mm

Zoom Scan (5x5x7)/Cube 0: Measurement grid: dx=8mm, dy=8mm, dz=5mm

Reference Value = 14.53 V/m; Power Drift = 0.18 dB

Peak SAR (extrapolated) = 0.515 W/kg

SAR(1 g) = 0.276 W/kg

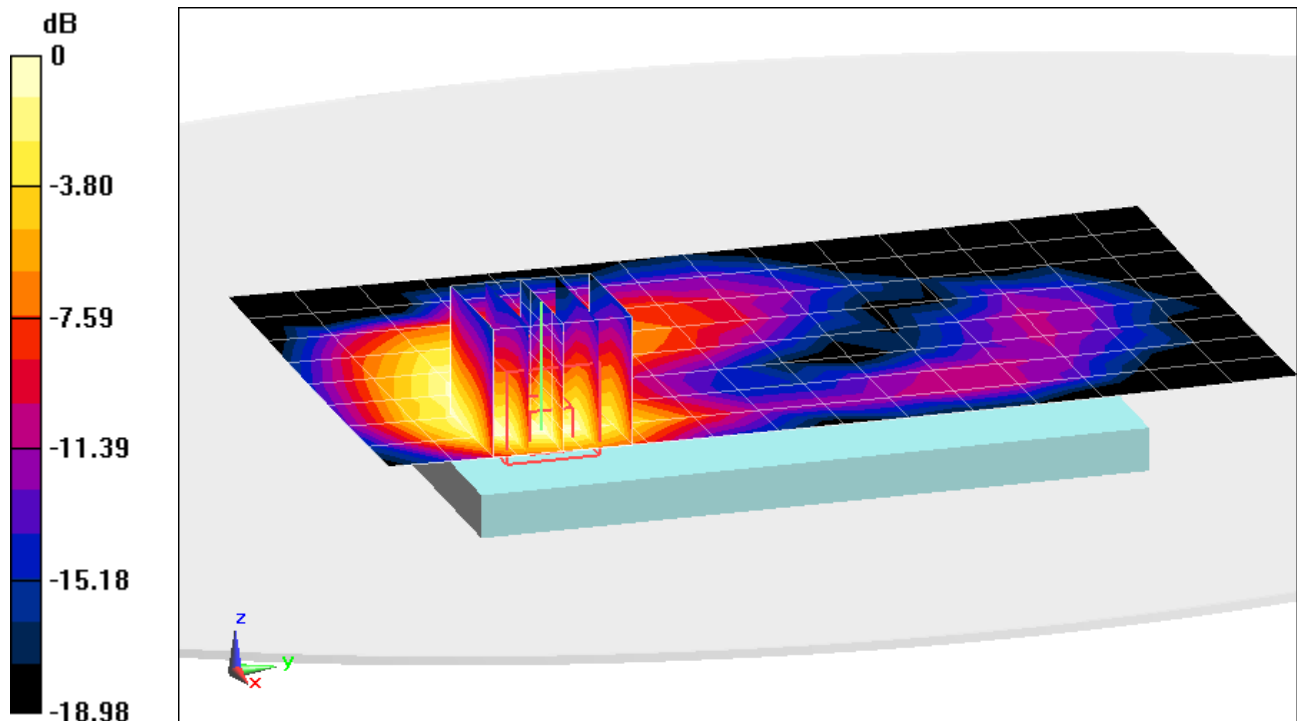

0 dB = 0.0570 W/kg = -12.44 dBW/kg

PCTEST ENGINEERING LABORATORY, INC.

DUT: A3LSMN915G; Type: Portable Handset; Serial: F238A

Communication System: UID 0, LTE Band 4 (AWS) (0); Frequency: 1732.5 MHz; Duty Cycle: 1:1

Medium: 1750 Body Medium parameters used (interpolated):

$f = 1732.5 \text{ MHz}$; $\sigma = 1.43 \text{ S/m}$; $\epsilon_r = 52.102$; $\rho = 1000 \text{ kg/m}^3$

Phantom section: Flat Section; Space: 1.0 cm

Test Date: 08-14-2014; Ambient Temp: 23.6°C; Tissue Temp: 23.8°C

Probe: ES3DV3 - SN3332; ConvF(4.93, 4.93, 4.93); Calibrated: 11/25/2013;

Sensor-Surface: 3mm (Mechanical Surface Detection)

Electronics: DAE4 Sn1407; Calibrated: 11/18/2013

Phantom: ELI v5.0; Type: QDOVA001BB; Serial: 1226

Measurement SW: DASY52, Version 52.8 (8); SEMCAD X Version 14.6.10 (7331)

Mode: LTE Band 4 (AWS), Body SAR, Bottom Edge, Mid.ch
20 MHz Bandwidth, QPSK, 1 RB, 99 RB Offset

Area Scan (13x7x1): Measurement grid: dx=5mm, dy=15mm

Zoom Scan (5x5x7)/Cube 0: Measurement grid: dx=8mm, dy=8mm, dz=5mm

Reference Value = 18.38 V/m; Power Drift = 0.18 dB

Peak SAR (extrapolated) = 0.740 W/kg

SAR(1 g) = 0.471 W/kg

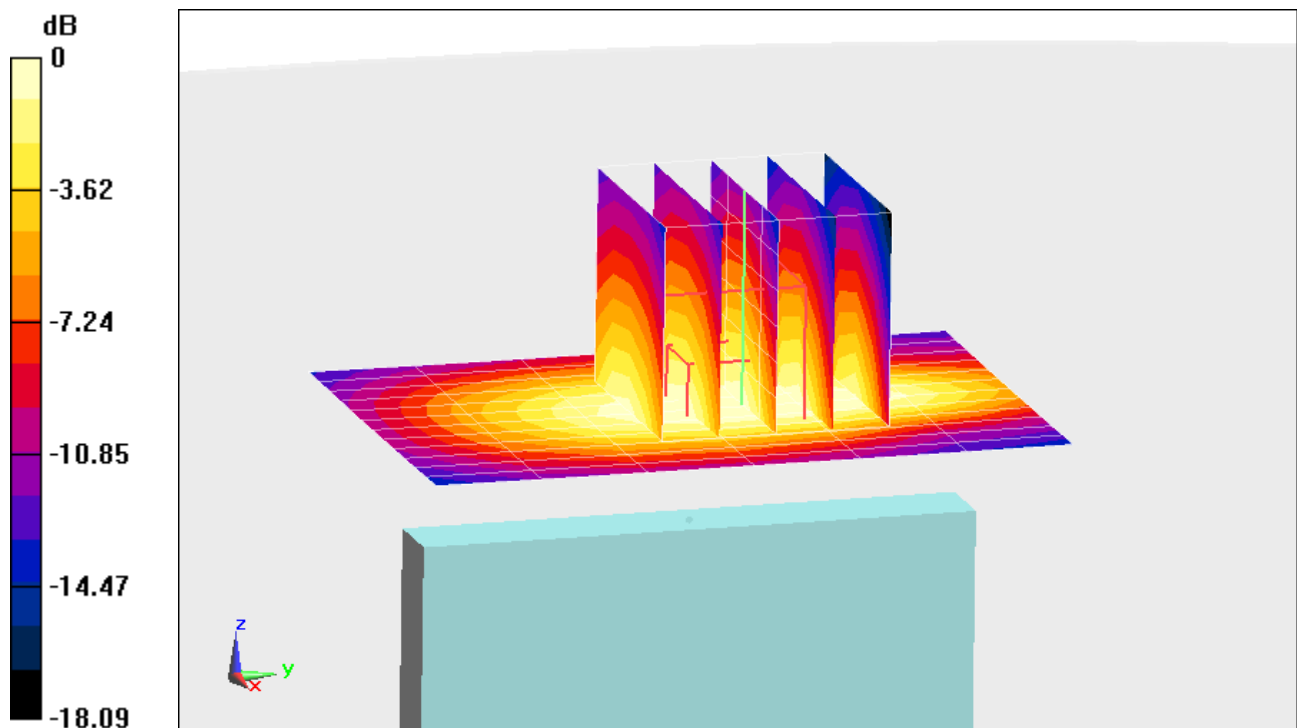

0 dB = 0.555 W/kg = -2.56 dBW/kg

PCTEST ENGINEERING LABORATORY, INC.

DUT: A3LSMN915G; Type: Portable Handset; Serial: F227C

Communication System: UID 0, LTE B2 (PCS) 20 MHz; Frequency: 1860 MHz; Duty Cycle: 1:1

Medium: 1900 Body Medium parameters used (interpolated):

$f = 1860 \text{ MHz}$; $\sigma = 1.505 \text{ S/m}$; $\epsilon_r = 51.259$; $\rho = 1000 \text{ kg/m}^3$

Phantom section: Flat Section; Space: 1.0 cm

Test Date: 08-14-2014; Ambient Temp: 22.9°C; Tissue Temp: 21.0°C

Probe: ES3DV3 - SN3288; ConvF(4.82, 4.82, 4.82); Calibrated: 9/23/2013;

Sensor-Surface: 3mm (Mechanical Surface Detection)

Electronics: DAE4 Sn1323; Calibrated: 9/17/2013

Phantom: SAM with CRP; Type: SAM; Serial: TP1375

Measurement SW: DASY4, Version 4.7 (80); SEMCAD X Version 14.6.10 (7331)

Mode: LTE Band 2 (PCS), Body SAR, Back side, Low.ch
20 MHz Bandwidth, QPSK, 1 RB, 0 RB Offset

Area Scan (9x15x1): Measurement grid: dx=15mm, dy=15mm

Zoom Scan (5x5x7)/Cube 0: Measurement grid: dx=8mm, dy=8mm, dz=5mm

Reference Value = 12.98 V/m; Power Drift = -0.06 dB

Peak SAR (extrapolated) = 0.342 W/kg

SAR(1 g) = 0.224 W/kg

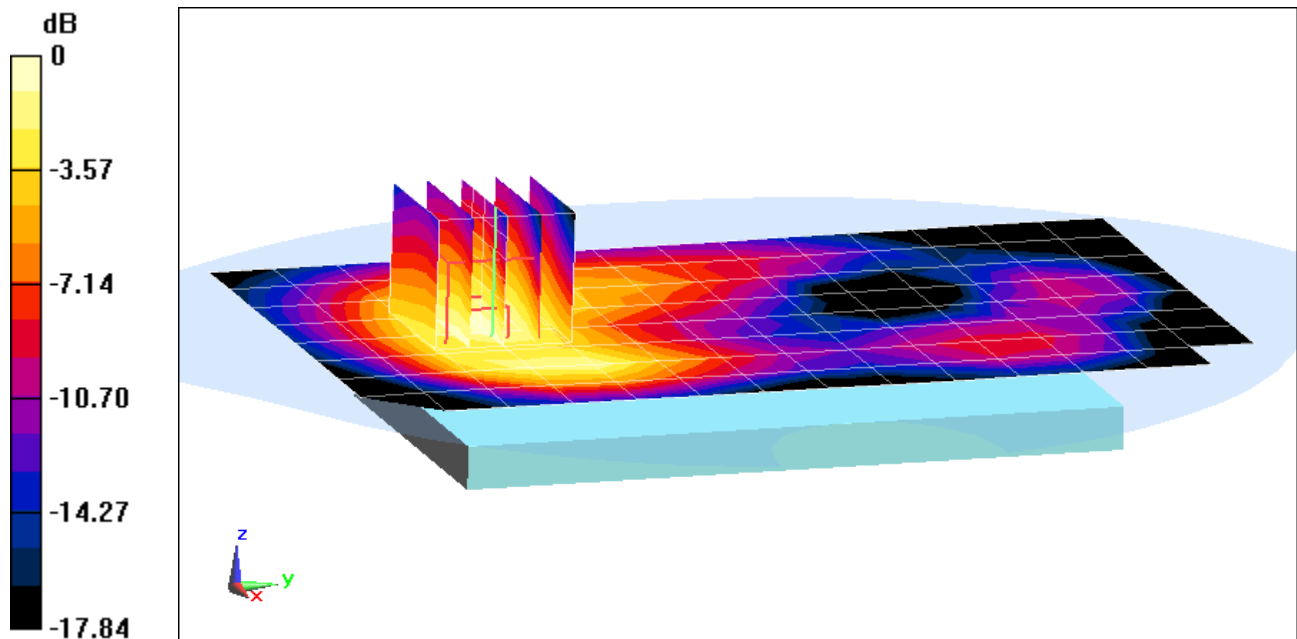

0 dB = 0.259 W/kg = -5.87 dBW/kg

PCTEST ENGINEERING LABORATORY, INC.

DUT: A3LSMN915G; Type: Portable Handset; Serial: F227C

Communication System: UID 0, LTE B2 (PCS) 20 MHz; Frequency: 1860 MHz; Duty Cycle: 1:1

Medium: 1900 Body Medium parameters used (interpolated):

$f = 1860 \text{ MHz}$; $\sigma = 1.505 \text{ S/m}$; $\epsilon_r = 51.259$; $\rho = 1000 \text{ kg/m}^3$

Phantom section: Flat Section; Space: 1.0 cm

Test Date: 08-14-2014; Ambient Temp: 22.9°C; Tissue Temp: 21.0°C

Probe: ES3DV3 - SN3288; ConvF(4.82, 4.82, 4.82); Calibrated: 9/23/2013;

Sensor-Surface: 3mm (Mechanical Surface Detection)

Electronics: DAE4 Sn1323; Calibrated: 9/17/2013

Phantom: SAM with CRP; Type: SAM; Serial: TP1375

Measurement SW: DASY4, Version 4.7 (80); SEMCAD X Version 14.6.10 (7331)

Mode: LTE Band 2 (PCS), Body SAR, Bottom Edge, Low.ch
20 MHz Bandwidth, QPSK, 1 RB, 0 RB Offset

Area Scan (11x7x1): Measurement grid: dx=5mm, dy=15mm

Zoom Scan (5x5x7)/Cube 0: Measurement grid: dx=8mm, dy=8mm, dz=5mm

Reference Value = 21.77 V/m; Power Drift = 0.02 dB

Peak SAR (extrapolated) = 1.06 W/kg

SAR(1 g) = 0.642 W/kg

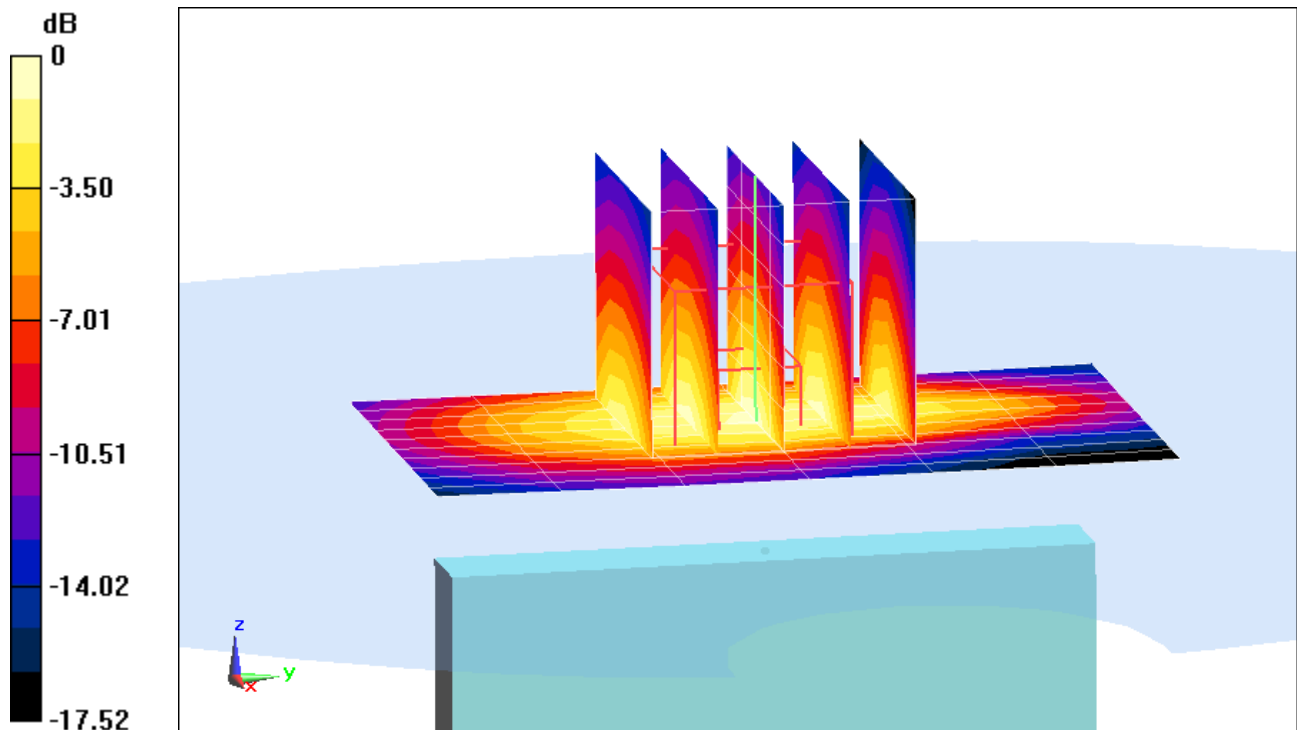

0 dB = 0.767 W/kg = -1.15 dBW/kg

PCTEST ENGINEERING LABORATORY, INC.

DUT: A3LSMN915G; Type: Portable Handset; Serial: F2279

Communication System: UID 0, IEEE 802.11b (0); Frequency: 2437 MHz; Duty Cycle: 1:1

Medium: 2450 Body Medium parameters used (interpolated):

$$f = 2437 \text{ MHz}; \sigma = 1.954 \text{ S/m}; \epsilon_r = 51.99; \rho = 1000 \text{ kg/m}^3$$

Phantom section: Flat Section; Space: 1.0 cm

Test Date: 08-18-2014; Ambient Temp: 24.5°C; Tissue Temp: 23.2°C

Probe: ES3DV3 - SN3319; ConvF(4.24, 4.24, 4.24); Calibrated: 4/17/2014;

Sensor-Surface: 3mm (Mechanical Surface Detection)

Electronics: DAE4 Sn1368; Calibrated: 4/11/2014

Phantom: ELI left; Type: QDOVA002AA; Serial: TP:1202

Measurement SW: DASY52, Version 52.8 (8); SEMCAD X Version 14.6.10 (7331)

Mode: IEEE 802.11b, Antenna 1, Body SAR, Ch 06, 1 Mbps, Back Side

Area Scan (11x18x1): Measurement grid: dx=12mm, dy=12mm

Zoom Scan (7x7x7)/Cube 0: Measurement grid: dx=5mm, dy=5mm, dz=5mm

Reference Value = 6.340 V/m; Power Drift = 0.04 dB

Peak SAR (extrapolated) = 0.143 W/kg

SAR(1 g) = 0.069 W/kg

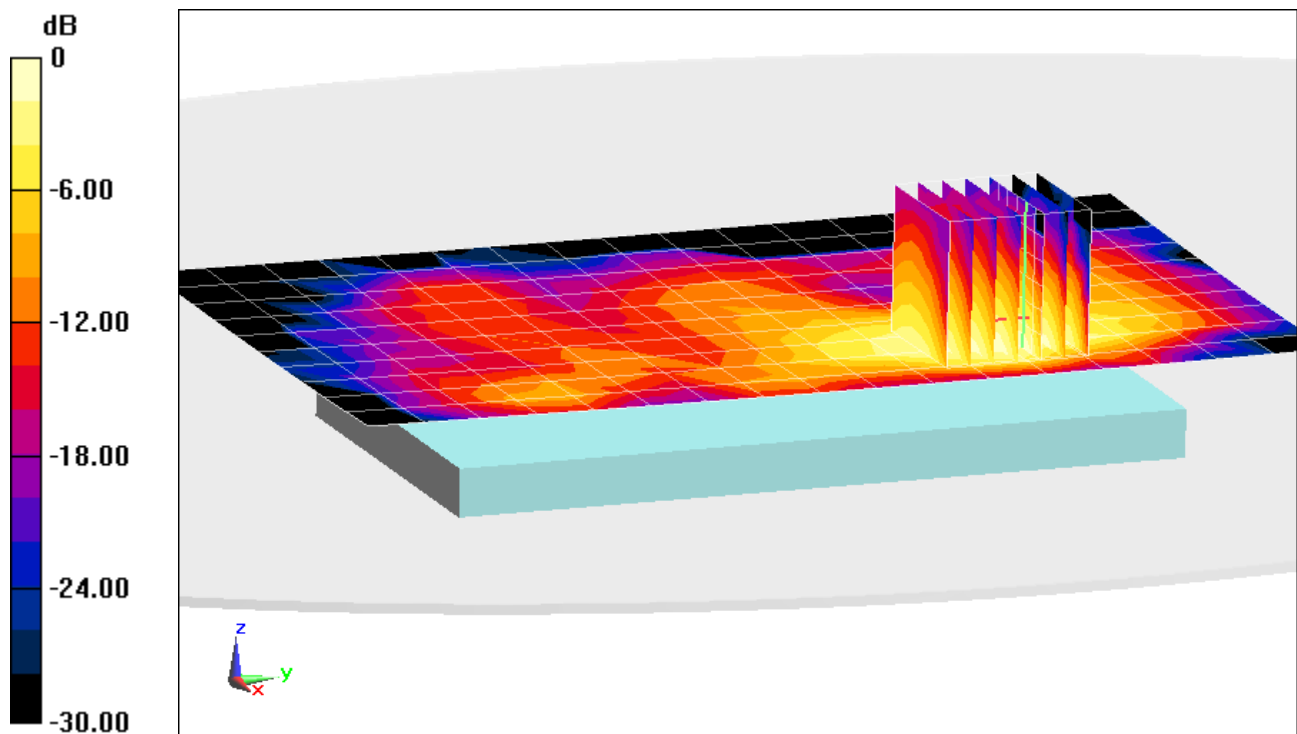

PCTEST ENGINEERING LABORATORY, INC.

DUT: A3LSMN915G; Type: Portable Handset; Serial: F227C

Communication System: UID 0, IEEE 802.11a 5.2-5.8 GHz Band; Frequency: 5745 MHz; Duty Cycle: 1:1

Medium: 5 GHz Body Medium parameters used:

$$f = 5745 \text{ MHz}; \sigma = 5.829 \text{ S/m}; \epsilon_r = 46.499; \rho = 1000 \text{ kg/m}^3$$

Phantom section: Flat Section; Space: 1.0 cm

Test Date: 08-18-2014; Ambient Temp: 23.4°C; Tissue Temp: 21.8°C

Probe: EX3DV4 - SN3920; ConvF(4, 4, 4); Calibrated: 12/18/2013;

Sensor-Surface: 1.4mm (Mechanical Surface Detection)

Electronics: DAE4 Sn649; Calibrated: 12/12/2013

Phantom: SAM Sub; Type: SAM 4.0; Serial: TP-1357

Measurement SW: DASY4, Version 4.7 (80); SEMCAD X Version 14.6.10 (7331)

Mode: IEEE 802.11a, Antenna 1, 5.8 GHz, Body SAR, Ch 149, 6 Mbps, Back Side

Area Scan (13x21x1): Measurement grid: dx=10mm, dy=10mm

Zoom Scan (8x8x7)/Cube 0: Measurement grid: dx=4mm, dy=4mm, dz=1.4mm; Graded Ratio: 1.4

Reference Value = 5.535 V/m; Power Drift = 0.14 dB

Peak SAR (extrapolated) = 0.862 W/kg

SAR(1 g) = 0.153 W/kg

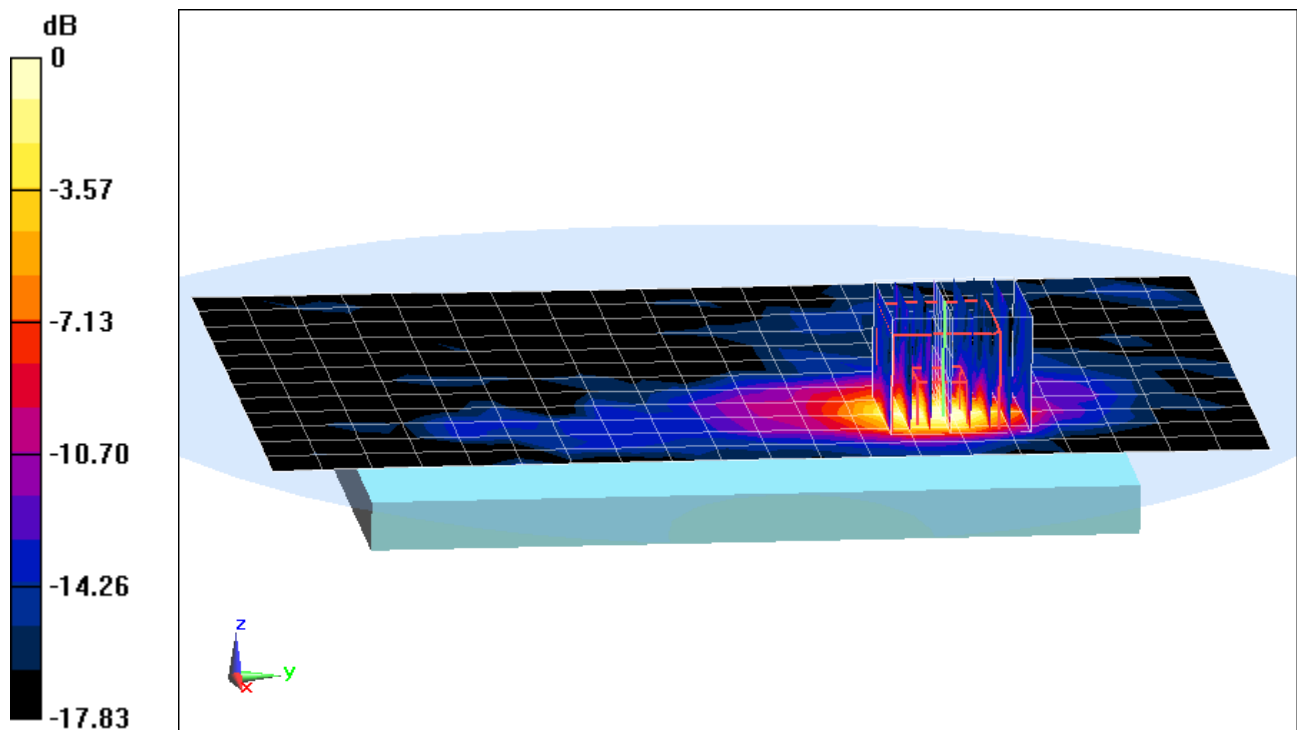

0 dB = 0.363 W/kg = -4.40 dBW/kg

PCTEST ENGINEERING LABORATORY, INC.

DUT: A3LSMN915G; Type: Portable Handset; Serial: F227C

Communication System: UID 0, IEEE 802.11a 5.2-5.8 GHz Band; Frequency: 5700 MHz; Duty Cycle: 1:1

Medium: 5 GHz Body Medium parameters used:

$$f = 5700 \text{ MHz}; \sigma = 5.78 \text{ S/m}; \epsilon_r = 46.55; \rho = 1000 \text{ kg/m}^3$$

Phantom section: Flat Section; Space: 1.0 cm

Test Date: 08-18-2014; Ambient Temp: 23.4°C; Tissue Temp: 21.8°C

Probe: EX3DV4 - SN3920; ConvF(3.62, 3.62, 3.62); Calibrated: 12/18/2013;

Sensor-Surface: 1.4mm (Mechanical Surface Detection)

Electronics: DAE4 Sn649; Calibrated: 12/12/2013

Phantom: SAM Sub; Type: SAM 4.0; Serial: TP-1357

Measurement SW: DASY4, Version 4.7 (80); SEMCAD X Version 14.6.10 (7331)

Mode: IEEE 802.11a, Antenna 2, 5.5 GHz, Body SAR, Ch 140, 6 Mbps

Area Scan (13x21x1): Measurement grid: dx=10mm, dy=10mm

Zoom Scan (8x8x7)/Cube 0: Measurement grid: dx=4mm, dy=4mm, dz=1.4mm; Graded Ratio: 1.4

Reference Value = 8.851 V/m; Power Drift = -0.18 dB

Peak SAR (extrapolated) = 1.59 W/kg

SAR(1 g) = 0.403 W/kg

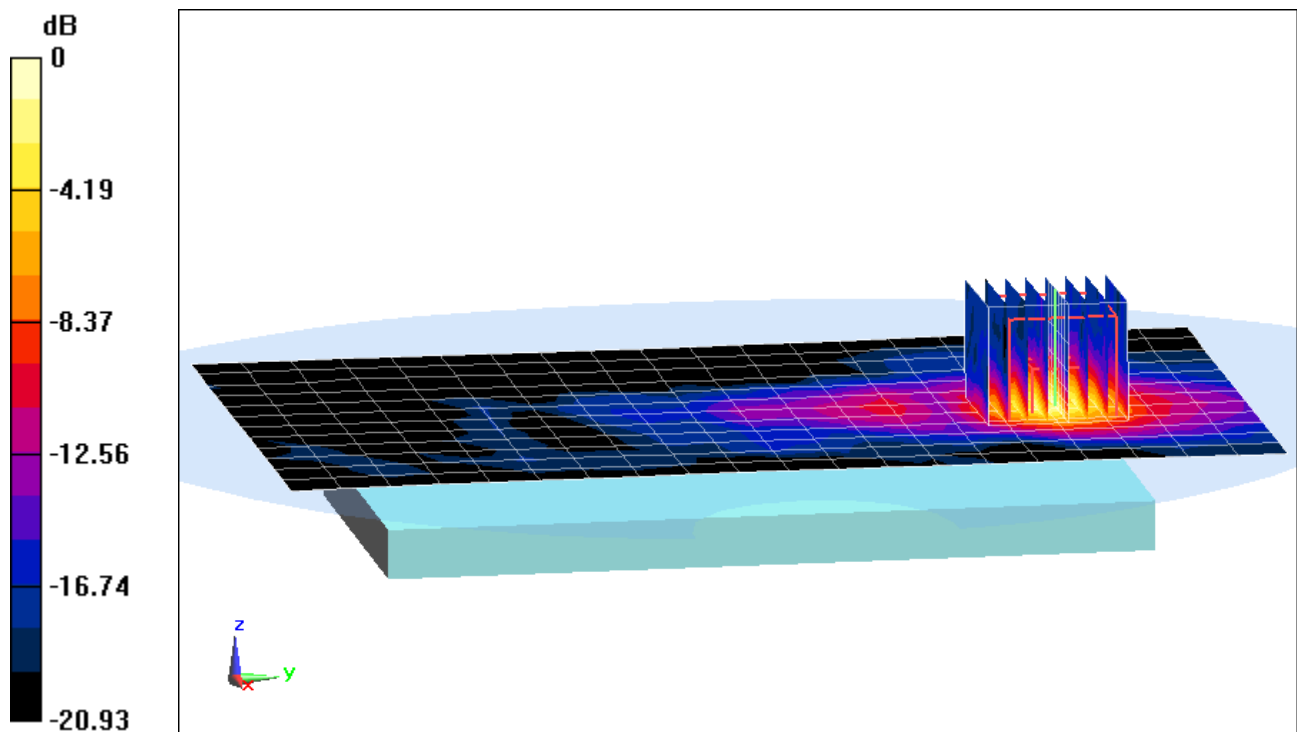

0 dB = 1.03 W/kg = 0.13 dBW/kg

PCTEST ENGINEERING LABORATORY, INC.

DUT: A3LSMN915G; Type: Portable Handset; Serial: F227C

Communication System: UID 0, IEEE 802.11a 5.2-5.8 GHz Band; Frequency: 5745 MHz; Duty Cycle: 1:1

Medium: 5 GHz Body Medium parameters used:

$$f = 5745 \text{ MHz}; \sigma = 5.829 \text{ S/m}; \epsilon_r = 46.499; \rho = 1000 \text{ kg/m}^3$$

Phantom section: Flat Section; Space: 0.0 cm

Test Date: 08-18-2014; Ambient Temp: 23.4°C; Tissue Temp: 21.8°C

Probe: EX3DV4 - SN3920; ConvF(4, 4, 4); Calibrated: 12/18/2013;

Sensor-Surface: 1.4mm (Mechanical Surface Detection)

Electronics: DAE4 Sn649; Calibrated: 12/12/2013

Phantom: SAM Sub; Type: SAM 4.0; Serial: TP-1357

Measurement SW: DASY4, Version 4.7 (80); SEMCAD X Version 14.6.10 (7331)

Mode: IEEE 802.11a, Antenna 1, 5.8 GHz, Hand SAR, Ch 149, 6 Mbps, Back Side

Area Scan (13x21x1): Measurement grid: dx=10mm, dy=10mm

Zoom Scan (10x10x7)/Cube 0: Measurement grid: dx=4mm, dy=4mm, dz=1.4mm; Graded Ratio: 1.4

Reference Value = 17.41 V/m; Power Drift = 0.12 dB

Peak SAR (extrapolated) = 17.1 W/kg

SAR(10 g) = 0.259 W/kg

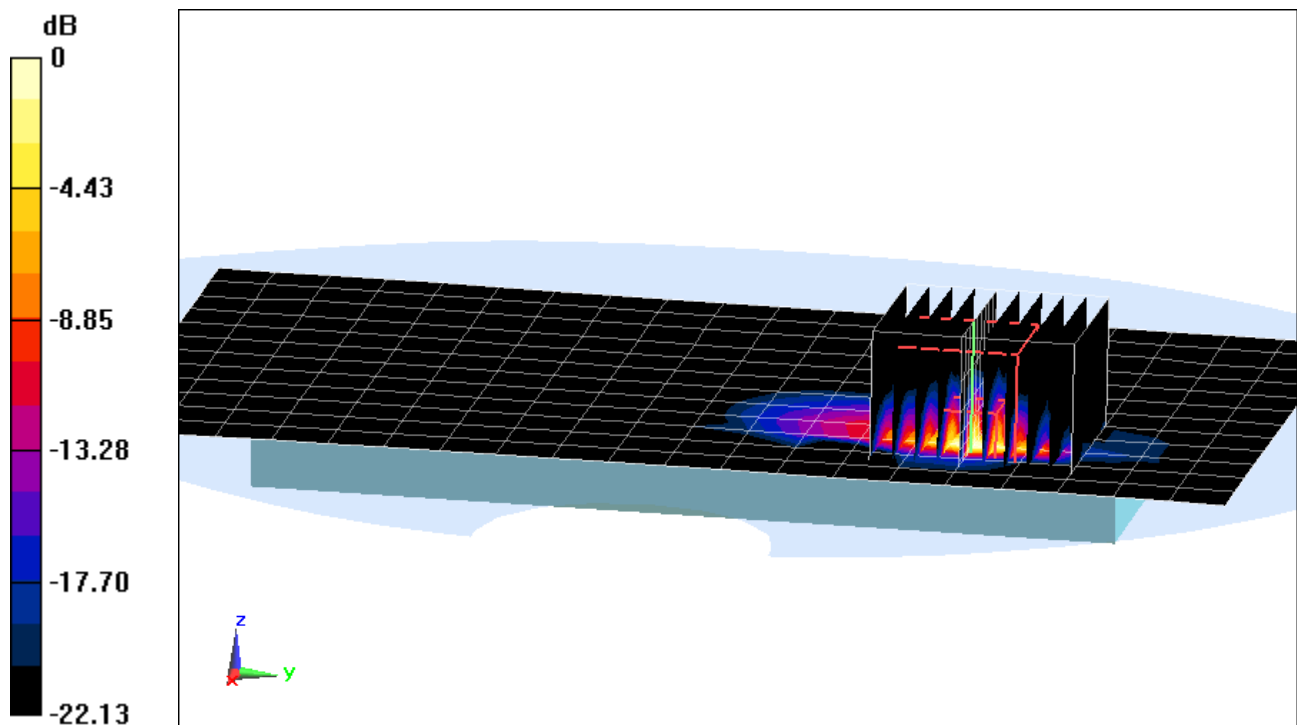

0 dB = 3.22 W/kg = 5.08 dBW/kg

PCTEST ENGINEERING LABORATORY, INC.

DUT: A3LSMN915G; Type: Portable Handset; Serial: F227C

Communication System: UID 0, IEEE 802.11a 5.2-5.8 GHz Band; Frequency: 5700 MHz; Duty Cycle: 1:1

Medium: 5 GHz Body Medium parameters used:

$$f = 5700 \text{ MHz}; \sigma = 5.78 \text{ S/m}; \epsilon_r = 46.55; \rho = 1000 \text{ kg/m}^3$$

Phantom section: Flat Section; Space: 0.0 cm

Test Date: 08-18-2014; Ambient Temp: 23.4°C; Tissue Temp: 21.8°C

Probe: EX3DV4 - SN3920; ConvF(3.62, 3.62, 3.62); Calibrated: 12/18/2013;

Sensor-Surface: 1.4mm (Mechanical Surface Detection)

Electronics: DAE4 Sn649; Calibrated: 12/12/2013

Phantom: SAM Sub; Type: SAM 4.0; Serial: TP-1357

Measurement SW: DASY4, Version 4.7 (80); SEMCAD X Version 14.6.10 (7331)

Mode: IEEE 802.11a, Antenna 2, 5.5 GHz, Hand SAR, Ch 140, 6 Mbps, Back Side

Area Scan (13x21x1): Measurement grid: dx=10mm, dy=10mm

Zoom Scan (9x9x7)/Cube 0: Measurement grid: dx=4mm, dy=4mm, dz=1.4mm; Graded Ratio: 1.4

Reference Value = 35.70 V/m; Power Drift = -0.12 dB

Peak SAR (extrapolated) = 46.6 W/kg

SAR(10 g) = 1.24 W/kg

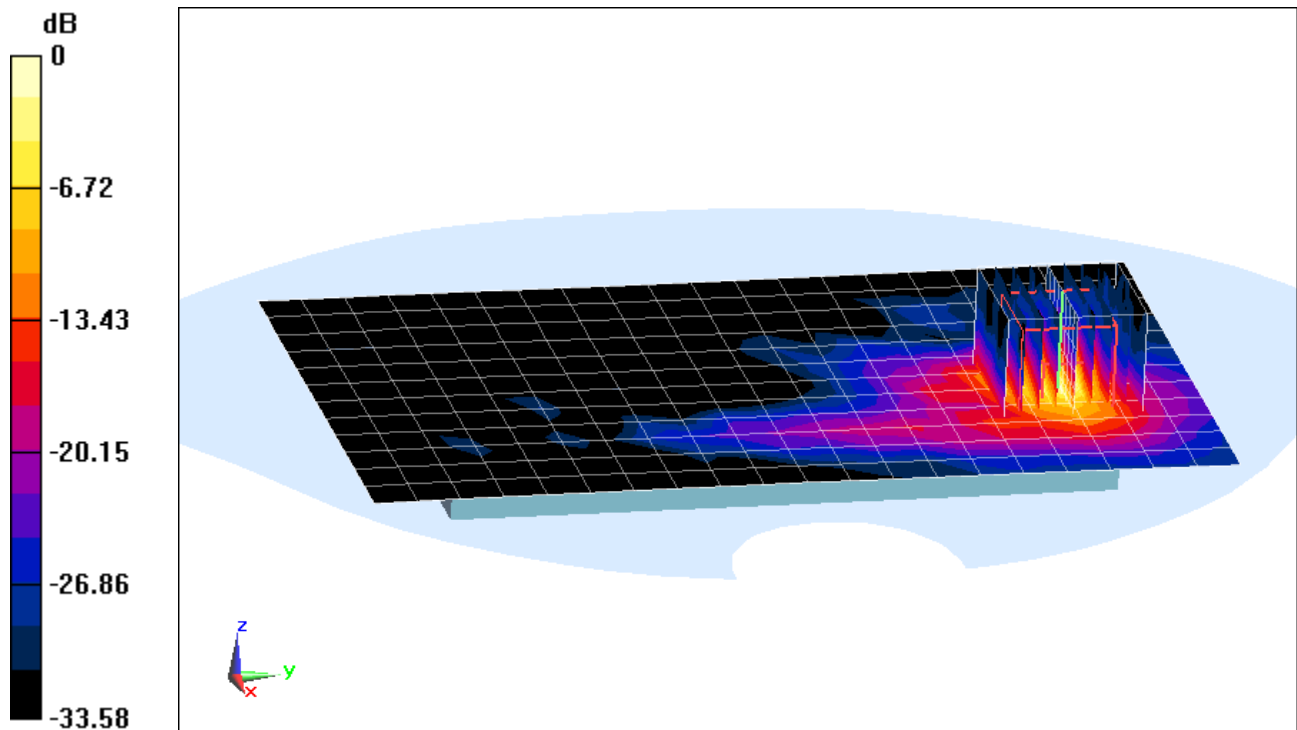

0 dB = 13.9 W/kg = 11.43 dBW/kg

APPENDIX B: SYSTEM VERIFICATION

PCTEST ENGINEERING LABORATORY, INC.

DUT: Dipole 835 MHz; Type: D835V2; Serial: 4d132

Communication System: UID 0, CW; Frequency: 835 MHz; Duty Cycle: 1:1

Medium: 835 Head Medium parameters used:

$f = 835 \text{ MHz}$; $\sigma = 0.911 \text{ S/m}$; $\epsilon_r = 42.176$; $\rho = 1000 \text{ kg/m}^3$

Phantom section: Flat Section; Space: 1.5 cm

Test Date: 08-15-2014; Ambient Temp: 22.3°C; Tissue Temp: 20.2°C

Probe: ES3DV3 - SN3213; ConvF(6.37, 6.37, 6.37); Calibrated: 4/11/2014;

Sensor-Surface: 3mm (Mechanical Surface Detection)

Electronics: DAE4 Sn1364; Calibrated: 3/17/2014

Phantom: SAM Sub; Type: SAM 4.0; Serial: TP-1357

Measurement SW: DASY4, Version 4.7 (80); SEMCAD X Version 14.6.10 (7331)

835MHz System Verification

Area Scan (7x13x1): Measurement grid: dx=15mm, dy=15mm

Zoom Scan (5x5x7)/Cube 0: Measurement grid: dx=8mm, dy=8mm, dz=5mm

Input Power = 20 dBm (100 mW)

Peak SAR (extrapolated) = 1.47 W/kg

SAR(1 g) = 0.970 W/kg

Deviation 4.64%

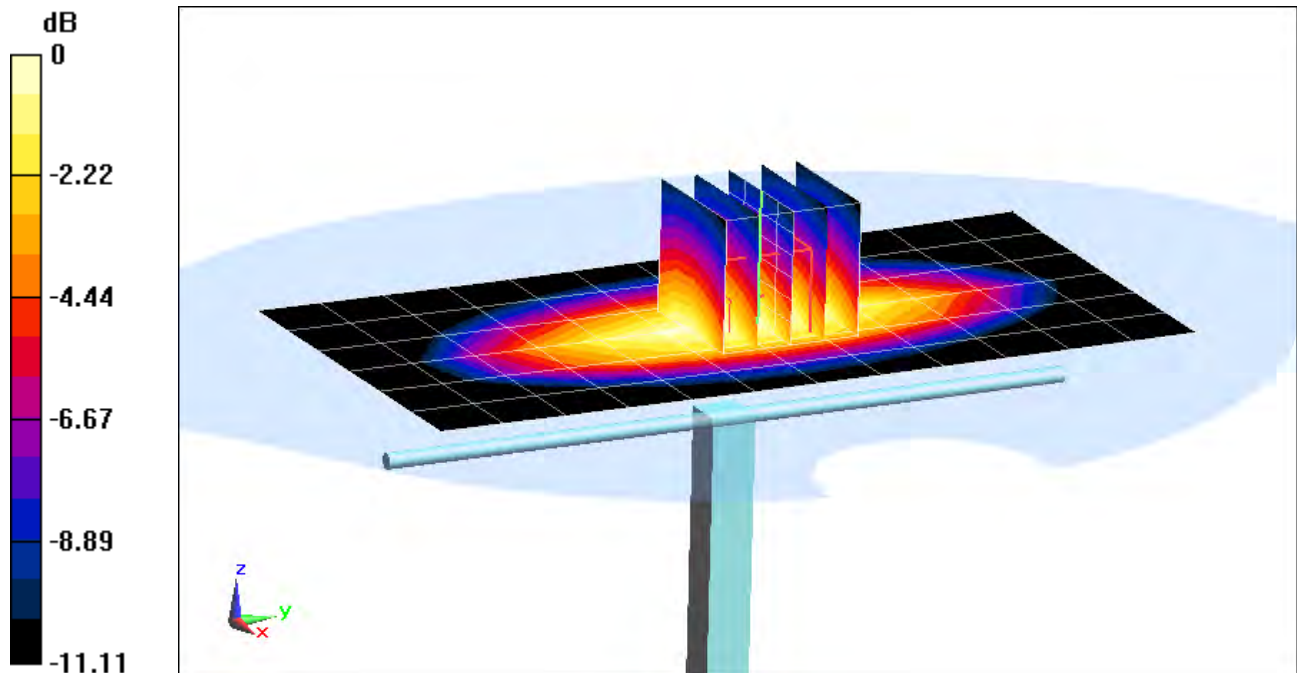

0 dB = 1.12 W/kg = 0.49 dBW/kg

PCTEST ENGINEERING LABORATORY, INC.

DUT: Dipole 1750 MHz; Type: D1765V2; Serial: 1008

Communication System: UID 0, CW; Frequency: 1750 MHz; Duty Cycle: 1:1

Medium: 1750 Head Medium parameters used:

$f = 1750 \text{ MHz}$; $\sigma = 1.357 \text{ S/m}$; $\epsilon_r = 39.027$; $\rho = 1000 \text{ kg/m}^3$

Phantom section: Flat Section; Space: 1.0 cm

Test Date: 08-18-2014; Ambient Temp: 24.8°C; Tissue Temp: 23.0°C

Probe: ES3DV3 - SN3263; ConvF(5.41, 5.41, 5.41); Calibrated: 5/15/2014;

Sensor-Surface: 3mm (Mechanical Surface Detection)

Electronics: DAE4 Sn859; Calibrated: 5/14/2014

Phantom: SAM v5.0 Left; Type: QD000P40CD; Serial: TP: 1687

Measurement SW: DASY52, Version 52.8 (8); SEMCAD X Version 14.6.10 (7331)

1750 MHz System Verification

Area Scan (7x9x1): Measurement grid: dx=15mm, dy=15mm

Zoom Scan (5x5x7)/Cube 0: Measurement grid: dx=8mm, dy=8mm, dz=5mm

Input Power = 20 dBm (100 mW)

Peak SAR (extrapolated) = 6.25 W/kg

SAR(1 g) = 3.51 W/kg

Deviation = -4.88%

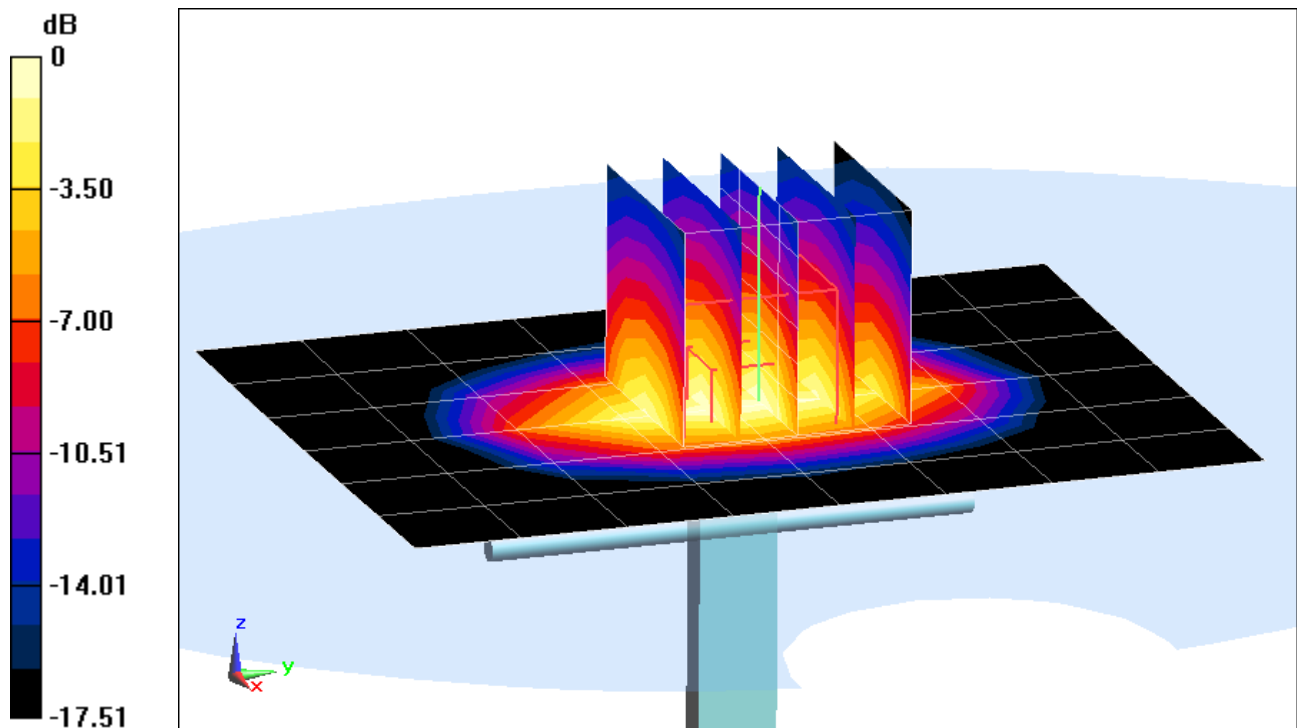

0 dB = 4.33 W/kg = 6.36 dBW/kg

PCTEST ENGINEERING LABORATORY, INC.

DUT: SAR Dipole 1900 MHz; Type: D1900V2; Serial: 5d148

Communication System: UID 0, CW; Frequency: 1900 MHz; Duty Cycle: 1:1

Medium: 1900 Head Medium parameters used (interpolated):

$f = 1900 \text{ MHz}$; $\sigma = 1.411 \text{ S/m}$; $\epsilon_r = 40.973$; $\rho = 1000 \text{ kg/m}^3$

Phantom section: Flat Section; Space: 1.0 cm

Test Date: 08-14-2014; Ambient Temp: 21.8°C; Tissue Temp: 20.4°C

Probe: ES3DV3 - SN3213; ConvF(4.99, 4.99, 4.99); Calibrated: 4/11/2014;

Sensor-Surface: 3mm (Mechanical Surface Detection)

Electronics: DAE4 Sn1364; Calibrated: 3/17/2014

Phantom: SAM Main; Type: SAM 4.0; Serial: TP-1406

Measurement SW: DASY4, Version 4.7 (80); SEMCAD X Version 14.6.10 (7331)

1900MHz System Verification

Area Scan (5x7x1): Measurement grid: dx=15mm, dy=15mm

Zoom Scan (5x5x7)/Cube 0: Measurement grid: dx=8mm, dy=8mm, dz=5mm

Input Power = 20 dBm (100 mW)

Peak SAR (extrapolated) = 6.88 W/kg

SAR(1 g) = 3.76 W/kg

Deviation = -7.62%

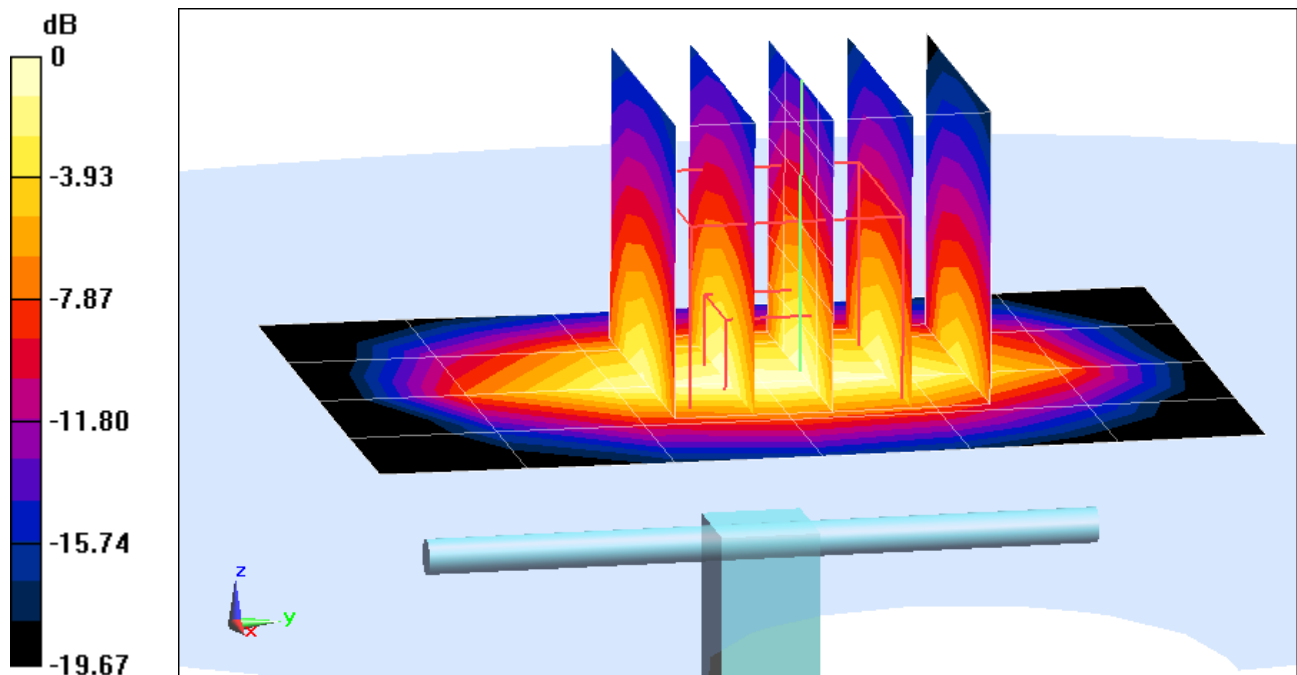

0 dB = 4.70 W/kg = 6.72 dBW/kg

PCTEST ENGINEERING LABORATORY, INC.

DUT: Dipole 2450 MHz; Type: D2450V2; Serial: 797

Communication System: UID 0, CW; Frequency: 2450 MHz; Duty Cycle: 1:1

Medium: 2450 Head Medium parameters used:

$f = 2450 \text{ MHz}$; $\sigma = 1.79 \text{ S/m}$; $\epsilon_r = 40.574$; $\rho = 1000 \text{ kg/m}^3$

Phantom section: Flat Section; Space: 1.0 cm

Test Date: 08-18-2014; Ambient Temp: 24.5°C; Tissue Temp: 22.0°C

Probe: ES3DV3 - SN3319; ConvF(4.45, 4.45, 4.45); Calibrated: 4/17/2014;

Sensor-Surface: 3mm (Mechanical Surface Detection)

Electronics: DAE4 Sn1368; Calibrated: 4/11/2014

Phantom: SAM; Type: QD000P40CD; Serial: TP:1758

Measurement SW: DASY52, Version 52.8 (8); SEMCAD X Version 14.6.10 (7331)

2450 MHz System Verification

Area Scan (8x9x1): Measurement grid: dx=12mm, dy=12mm

Zoom Scan (7x7x7)/Cube 0: Measurement grid: dx=5mm, dy=5mm, dz=5mm

Input Power = 20 dBm (100 mW)

Peak SAR (extrapolated) = 10.8 W/kg

SAR(1 g) = 5.33 W/kg

Deviation = 2.90%

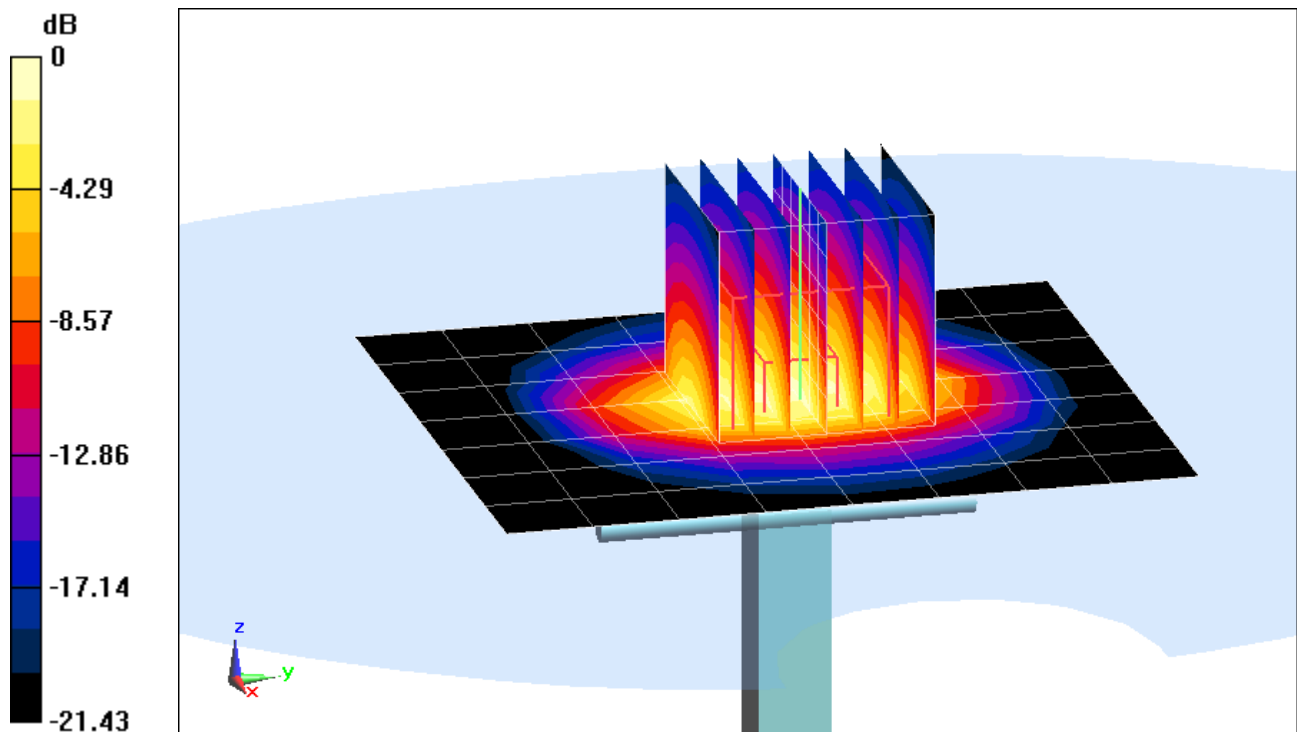

0 dB = 6.95 W/kg = 8.42 dBW/kg

PCTEST ENGINEERING LABORATORY, INC.

DUT: SAR Dipole 5200 MHz; Type: D5GHzV2; Serial: 1057

Communication System: UID 0, CW; Frequency: 5200 MHz; Duty Cycle: 1:1

Medium: 5 GHz Head Medium parameters used:

$f = 5200 \text{ MHz}$; $\sigma = 4.567 \text{ S/m}$; $\epsilon_r = 37.076$; $\rho = 1000 \text{ kg/m}^3$

Phantom section: Flat Section; Space: 1.0 cm

Test Date: 08-14-2014; Ambient Temp: 24.4°C; Tissue Temp: 23.6°C

Probe: EX3DV4 - SN3914; ConvF(4.99, 4.99, 4.99); Calibrated: 10/23/2013;

Sensor-Surface: 1.4mm (Mechanical Surface Detection)

Electronics: DAE4 Sn1333; Calibrated: 11/19/2013

Phantom: SAM V5.0 Right; Type: QD000P40CD; Serial: 1647

Measurement SW: DASY52, Version 52.8 (8); SEMCAD X Version 14.6.10 (7331)

5200 MHz System Verification

Area Scan (7x8x1): Measurement grid: dx=10mm, dy=10mm

Zoom Scan (7x7x7)/Cube 0: Measurement grid: dx=4mm, dy=4mm, dz=1.4mm; Graded Ratio: 1.4

Input Power = 20 dBm (100 mW)

Peak SAR (extrapolated) = 32.4 W/kg

SAR(1 g) = 7.54 W/kg

Deviation = -3.33%

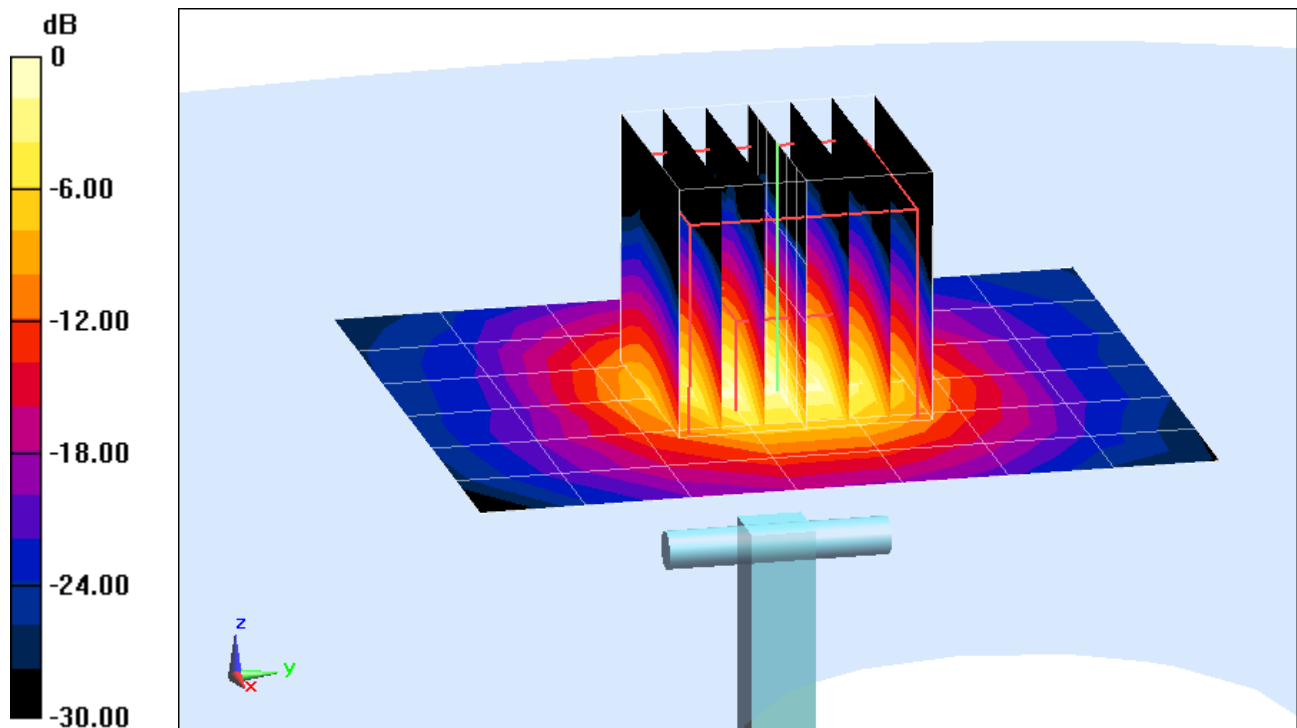

0 dB = 19.3 W/kg = 12.86 dBW/kg

PCTEST ENGINEERING LABORATORY, INC.

DUT: SAR Dipole 5300 MHz; Type: D5GHzV2; Serial: 1057

Communication System: UID 0, CW; Frequency: 5300 MHz; Duty Cycle: 1:1

Medium: 5 GHz Head Medium parameters used:

$f = 5300 \text{ MHz}$; $\sigma = 4.66 \text{ S/m}$; $\epsilon_r = 36.974$; $\rho = 1000 \text{ kg/m}^3$

Phantom section: Flat Section; Space: 1.0 cm

Test Date: 08-14-2014; Ambient Temp: 24.4°C; Tissue Temp: 23.6°C

Probe: EX3DV4 - SN3914; ConvF(4.82, 4.82, 4.82); Calibrated: 10/23/2013;

Sensor-Surface: 1.4mm (Mechanical Surface Detection)

Electronics: DAE4 Sn1333; Calibrated: 11/19/2013

Phantom: SAM V5.0 Right; Type: QD000P40CD; Serial: 1647

Measurement SW: DASY52, Version 52.8 (8); SEMCAD X Version 14.6.10 (7331)

5300 MHz System Verification

Area Scan (7x8x1): Measurement grid: dx=10mm, dy=10mm

Zoom Scan (7x7x7)/Cube 0: Measurement grid: dx=4mm, dy=4mm, dz=1.4mm; Graded Ratio: 1.4

Input Power = 20 dBm (100 mW)

Peak SAR (extrapolated) = 35.6 W/kg

SAR(1 g) = 8.14 W/kg

Deviation = -1.93%

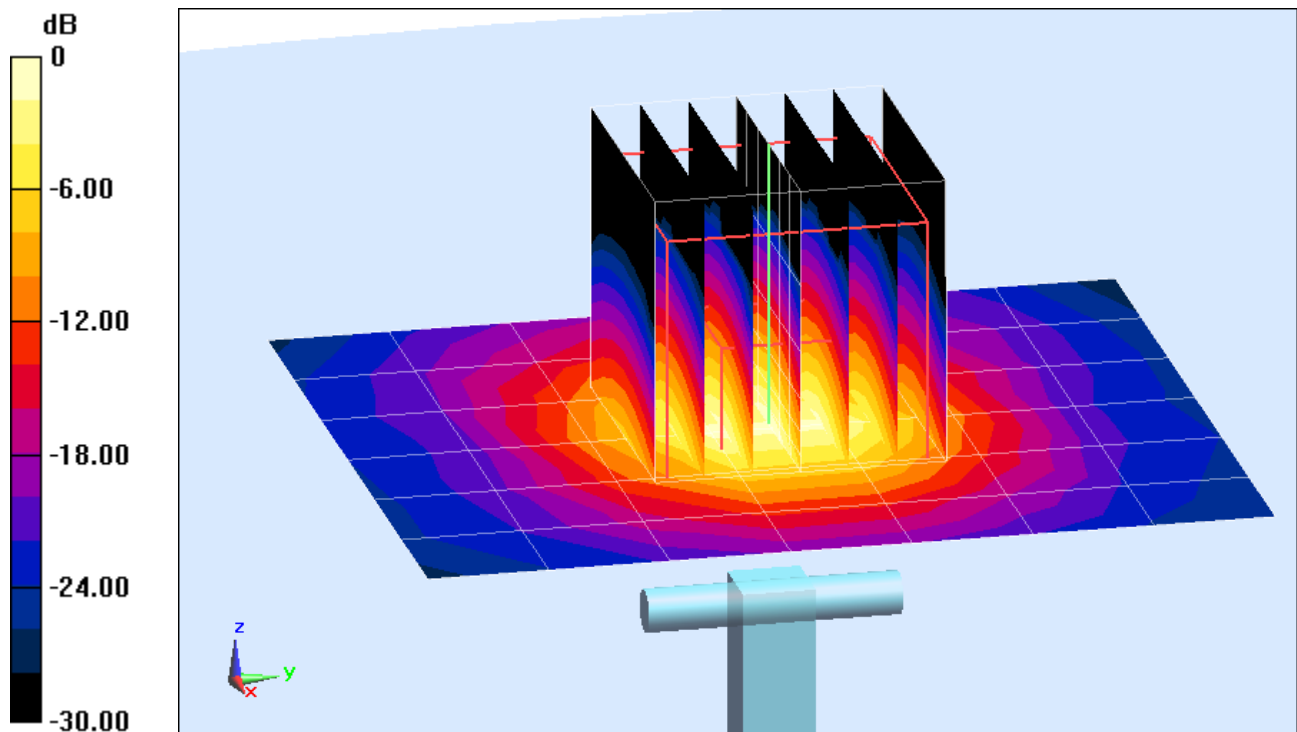

0 dB = 21.0 W/kg = 13.22 dBW/kg

PCTEST ENGINEERING LABORATORY, INC.

DUT: SAR Dipole 5500 MHz; Type: D5GHzV2; Serial: 1057

Communication System: UID 0, CW; Frequency: 5500 MHz; Duty Cycle: 1:1

Medium: 5 GHz Head Medium parameters used:

$f = 5500 \text{ MHz}$; $\sigma = 4.871 \text{ S/m}$; $\epsilon_r = 36.69$; $\rho = 1000 \text{ kg/m}^3$

Phantom section: Flat Section; Space: 1.0 cm

Test Date: 08-14-2014; Ambient Temp: 24.3°C; Tissue Temp: 23.7°C

Probe: EX3DV4 - SN3914; ConvF(4.55, 4.55, 4.55); Calibrated: 10/23/2013;

Sensor-Surface: 1.4mm (Mechanical Surface Detection)

Electronics: DAE4 Sn1333; Calibrated: 11/19/2013

Phantom: SAM V5.0 Right; Type: QD000P40CD; Serial: 1647

Measurement SW: DASY52, Version 52.8 (8); SEMCAD X Version 14.6.10 (7331)

5500 MHz System Verification

Area Scan (7x8x1): Measurement grid: dx=10mm, dy=10mm

Zoom Scan (7x7x7)/Cube 0: Measurement grid: dx=4mm, dy=4mm, dz=1.4mm; Graded Ratio: 1.4

Input Power = 20 dBm (100 mW)

Peak SAR (extrapolated) = 36.7 W/kg

SAR(1 g) = 8.23 W/kg

Deviation -2.37%

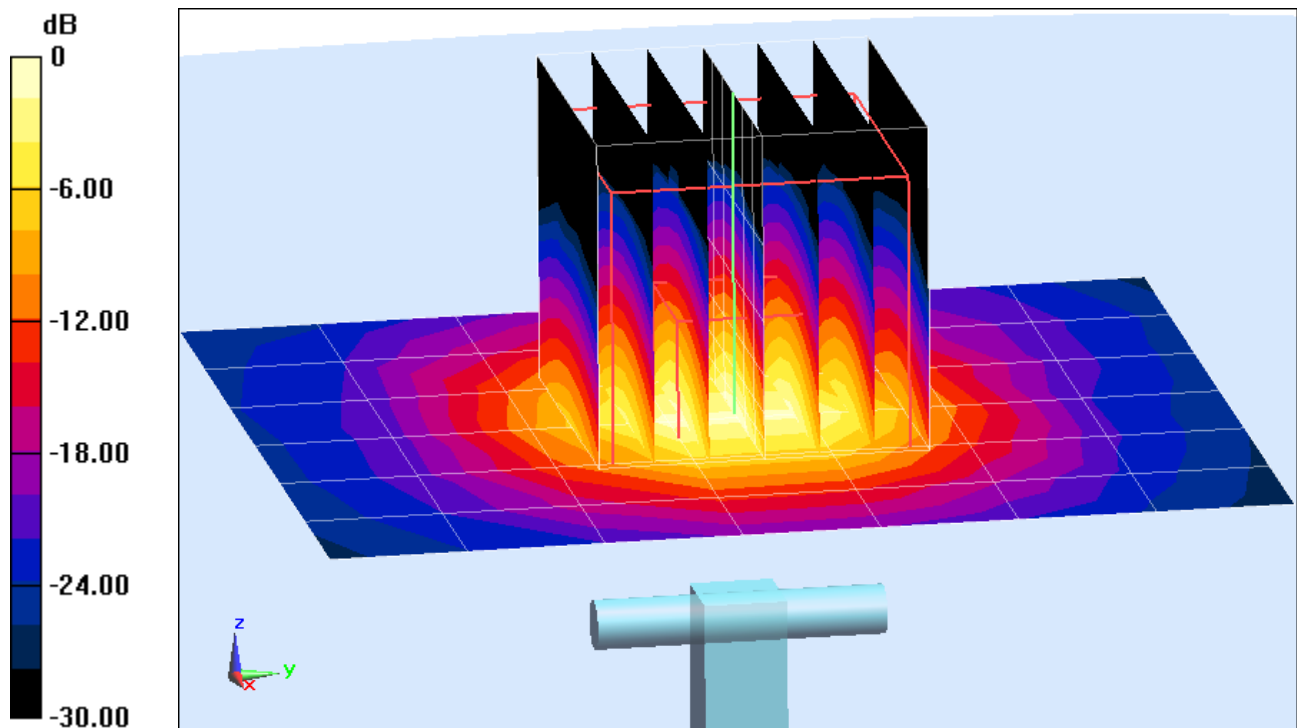

0 dB = 21.5 W/kg = 13.32 dBW/kg

PCTEST ENGINEERING LABORATORY, INC.

DUT: SAR Dipole 5600 MHz; Type: D5GHzV2; Serial: 1057

Communication System: UID 0, CW; Frequency: 5600 MHz; Duty Cycle: 1:1

Medium: 5 GHz Head Medium parameters used:

$f = 5600 \text{ MHz}$; $\sigma = 4.976 \text{ S/m}$; $\epsilon_r = 36.541$; $\rho = 1000 \text{ kg/m}^3$

Phantom section: Flat Section; Space: 1.0 cm

Test Date: 08-14-2014; Ambient Temp: 24.2°C; Tissue Temp: 23.8°C

Probe: EX3DV4 - SN3914; ConvF(4.37, 4.37, 4.37); Calibrated: 10/23/2013;

Sensor-Surface: 1.4mm (Mechanical Surface Detection)

Electronics: DAE4 Sn1333; Calibrated: 11/19/2013

Phantom: SAM V5.0 Right; Type: QD000P40CD; Serial: 1647

Measurement SW: DASY52, Version 52.8 (8); SEMCAD X Version 14.6.10 (7331)

5600 MHz System Verification

Area Scan (7x8x1): Measurement grid: dx=10mm, dy=10mm

Zoom Scan (7x7x7)/Cube 0: Measurement grid: dx=4mm, dy=4mm, dz=1.4mm; Graded Ratio: 1.4

Input Power = 20 dBm (100 mW)

Peak SAR (extrapolated) = 36.8 W/kg

SAR(1 g) = 8.18 W/kg

Deviation = -2.04%

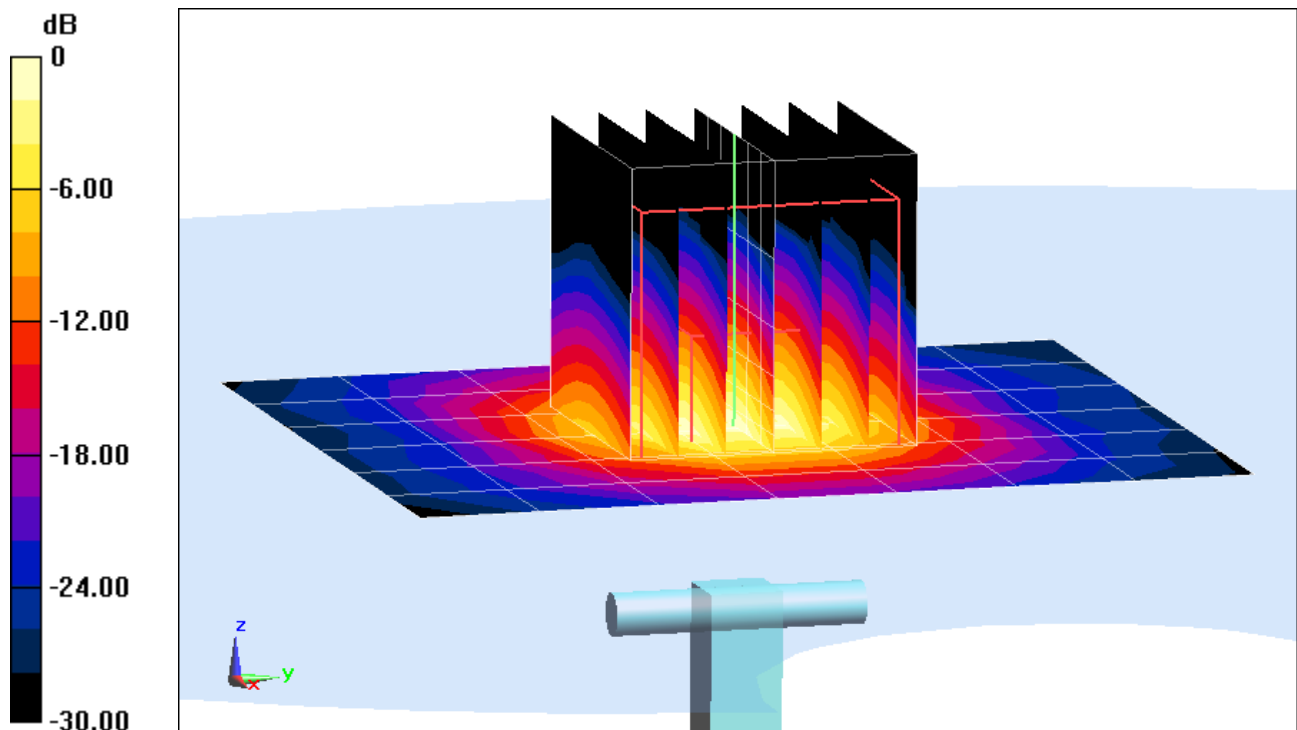

0 dB = 21.3 W/kg = 13.28 dBW/kg

PCTEST ENGINEERING LABORATORY, INC.

DUT: SAR Dipole 5800 MHz; Type: D5GHzV2; Serial: 1057

Communication System: UID 0, CW; Frequency: 5800 MHz; Duty Cycle: 1:1

Medium: 5 GHz Head Medium parameters used:

$f = 5800 \text{ MHz}$; $\sigma = 5.18 \text{ S/m}$; $\epsilon_r = 36.307$; $\rho = 1000 \text{ kg/m}^3$

Phantom section: Flat Section; Space: 1.0 cm

Test Date: 08-14-2014; Ambient Temp: 24.3°C; Tissue Temp: 23.6°C

Probe: EX3DV4 - SN3914; ConvF(4.52, 4.52, 4.52); Calibrated: 10/23/2013;

Sensor-Surface: 1.4mm (Mechanical Surface Detection)

Electronics: DAE4 Sn1333; Calibrated: 11/19/2013

Phantom: SAM V5.0 Right; Type: QD000P40CD; Serial: 1647

Measurement SW: DASY52, Version 52.8 (8); SEMCAD X Version 14.6.10 (7331)

5800 MHz System Verification

Area Scan (7x8x1): Measurement grid: dx=10mm, dy=10mm

Zoom Scan (7x7x7)/Cube 0: Measurement grid: dx=4mm, dy=4mm, dz=1.4mm; Graded Ratio: 1.4

Input Power = 20 dBm (100 mW)

Peak SAR (extrapolated) = 35.1 W/kg

SAR(1 g) = 7.39 W/kg

Deviation = -6.81%

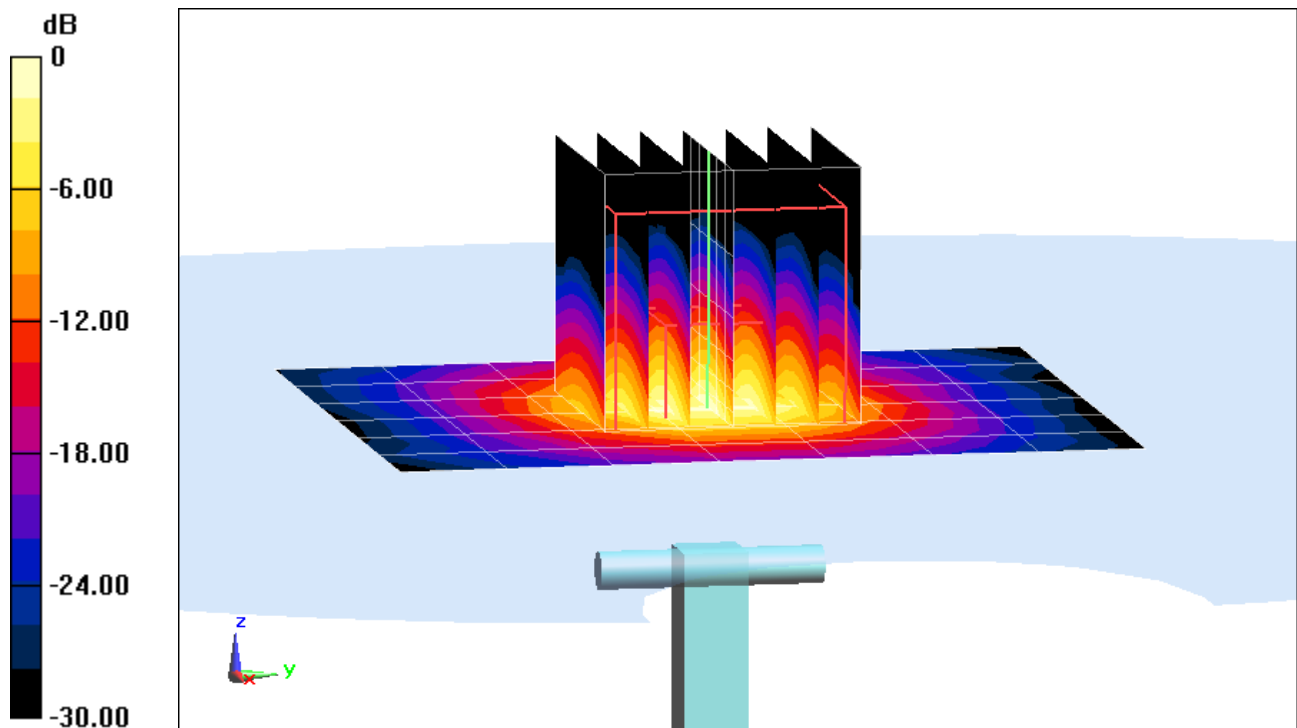

0 dB = 19.6 W/kg = 12.92 dBW/kg

PCTEST ENGINEERING LABORATORY, INC.

DUT: Dipole 835 MHz; Type: D835V2; Serial: 4d119

Communication System: UID 0, CW; Frequency: 835 MHz; Duty Cycle: 1:1

Medium: 835 Body Medium parameters used:

$f = 835 \text{ MHz}$; $\sigma = 0.997 \text{ S/m}$; $\epsilon_r = 53.013$; $\rho = 1000 \text{ kg/m}^3$

Phantom section: Flat Section; Space: 1.5 cm

Test Date: 08-14-2014; Ambient Temp: 23.9°C; Tissue Temp: 23.1°C

Probe: ES3DV3 - SN3263; ConvF(6.16, 6.16, 6.16); Calibrated: 5/15/2014;

Sensor-Surface: 3mm (Mechanical Surface Detection)

Electronics: DAE4 Sn859; Calibrated: 5/14/2014

Phantom: SAM v5.0 front; Type: QD000P40CD; Serial: TP-1646

Measurement SW: DASYS2, Version 52.8 (8); SEMCAD X Version 14.6.10 (7331)

835 MHz System Verification

Area Scan (7x14x1): Measurement grid: dx=15mm, dy=15mm

Zoom Scan (5x5x7)/Cube 0: Measurement grid: dx=8mm, dy=8mm, dz=5mm

Input Power = 20 dBm (100 mW)

Peak SAR (extrapolated) = 1.35 W/kg

SAR(1 g) = 0.912 W/kg

Deviation = -2.36%

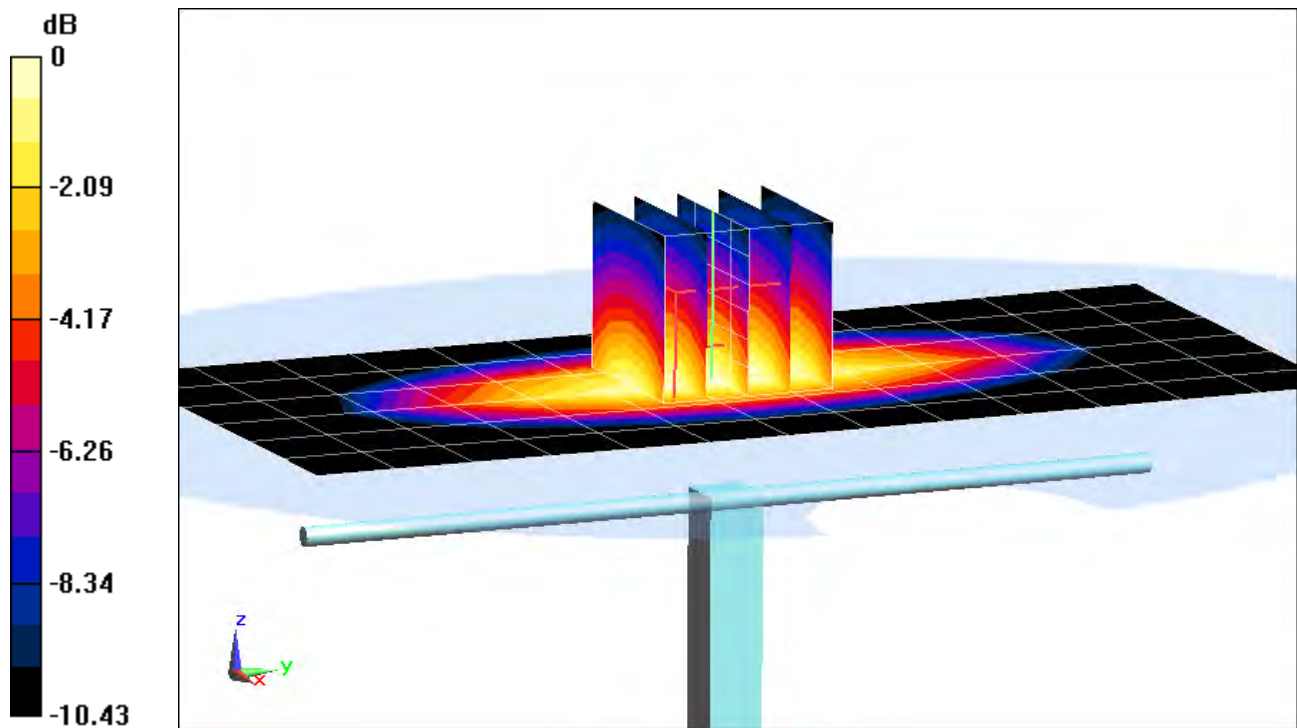

0 dB = 1.07 W/kg = 0.29 dBW/kg

PCTEST ENGINEERING LABORATORY, INC.

DUT: Dipole 1765 MHz; Type: D1765V2; Serial: 1008

Communication System: UID 0, CW; Frequency: 1750 MHz; Duty Cycle: 1:1

Medium: 1750 Body Medium parameters used:

$f = 1750 \text{ MHz}$; $\sigma = 1.448 \text{ S/m}$; $\epsilon_r = 52.043$; $\rho = 1000 \text{ kg/m}^3$

Phantom section: Flat Section; Space: 1.0 cm

Test Date: 08-14-2014; Ambient Temp: 23.6°C; Tissue Temp: 23.8°C

Probe: ES3DV3 - SN3332; ConvF(4.93, 4.93, 4.93); Calibrated: 11/25/2013;

Sensor-Surface: 3mm (Mechanical Surface Detection)

Electronics: DAE4 Sn1407; Calibrated: 11/18/2013

Phantom: ELI v5.0; Type: QDOVA001BB; Serial: 1226

Measurement SW: DASY52, Version 52.8 (8); SEMCAD X Version 14.6.10 (7331)

1750 MHz System Verification

Area Scan (7x9x1): Measurement grid: dx=15mm, dy=15mm

Zoom Scan (5x5x7)/Cube 0: Measurement grid: dx=8mm, dy=8mm, dz=5mm

Input Power = 20 dBm (100 mW)

Peak SAR (extrapolated) = 6.92 W/kg

SAR(1 g) = 4 W/kg

Deviation = 6.38%

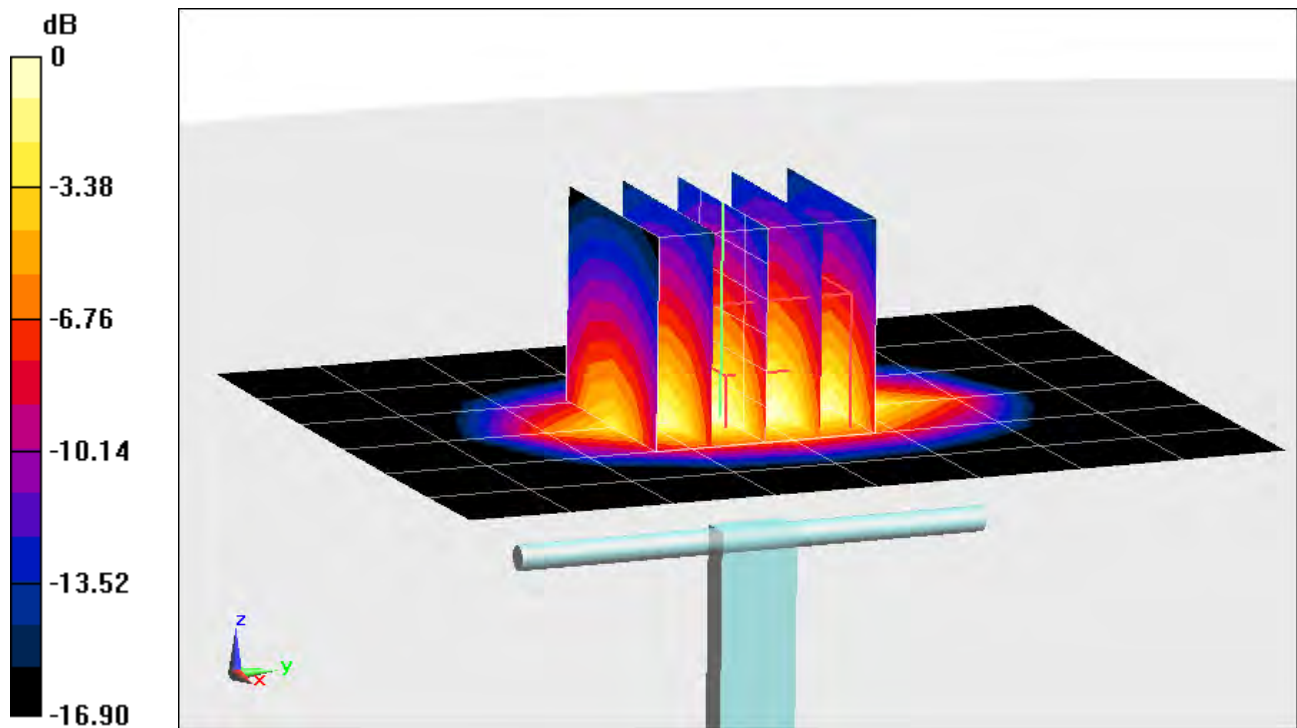

0 dB = 4.91 W/kg = 6.91 dBW/kg

PCTEST ENGINEERING LABORATORY, INC.

DUT: Dipole 1900 MHz; Type: D1900V2; Serial: 5d141

Communication System: UID 0, CW; Frequency: 1900 MHz; Duty Cycle: 1:1

Medium: 1900 Body Medium parameters used (interpolated):

$f = 1900 \text{ MHz}$; $\sigma = 1.513 \text{ S/m}$; $\epsilon_r = 51.825$; $\rho = 1000 \text{ kg/m}^3$

Phantom section: Flat Section; Space: 1.0 cm

Test Date: 08-14-2014; Ambient Temp: 24.2°C; Tissue Temp: 22.3°C

Probe: ES3DV3 - SN3287; ConvF(4.67, 4.67, 4.67); Calibrated: 11/20/2013;

Sensor-Surface: 3mm (Mechanical Surface Detection)

Electronics: DAE4 Sn1408; Calibrated: 11/19/2013

Phantom: ELI v5.0; Type: QDOVA001BB; Serial: 1229

Measurement SW: DASY52, Version 52.8 (8); SEMCAD X Version 14.6.10 (7331)

1900 MHz System Verification

Area Scan (7x10x1): Measurement grid: dx=15mm, dy=15mm

Zoom Scan (5x5x7)/Cube 0: Measurement grid: dx=8mm, dy=8mm, dz=5mm

Input Power = 20 dBm (100 mW)

Peak SAR (extrapolated) = 7.42 W/kg

SAR(1 g) = 4.18 W/kg

Deviation = 2.96%

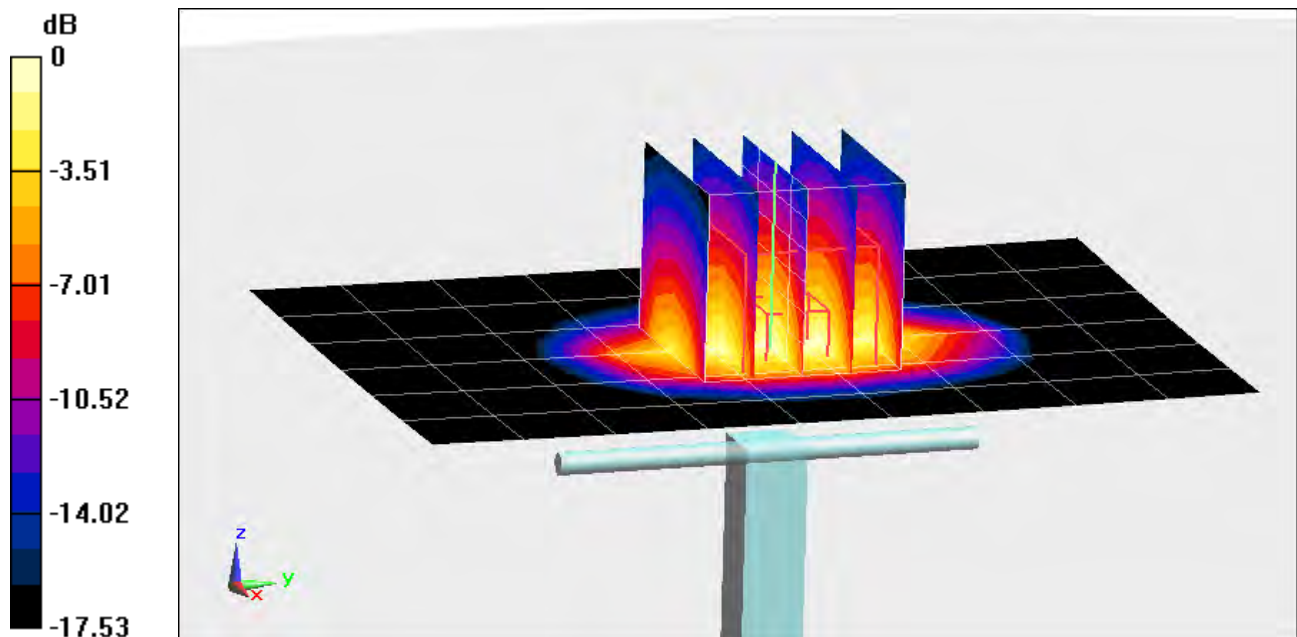

0 dB = 5.23 W/kg = 7.19 dBW/kg

PCTEST ENGINEERING LABORATORY, INC.

DUT: SAR Dipole 1900 MHz; Type: D1900V2; Serial: 5d148

Communication System: UID 0, CW; Frequency: 1900 MHz; Duty Cycle: 1:1

Medium: 1900 Body Medium parameters used (interpolated):

$f = 1900 \text{ MHz}$; $\sigma = 1.569 \text{ S/m}$; $\epsilon_r = 51.687$; $\rho = 1000 \text{ kg/m}^3$

Phantom section: Flat Section; Space: 1.0 cm

Test Date: 08-18-2014; Ambient Temp: 23.0°C; Tissue Temp: 22.2°C

Probe: ES3DV3 - SN3288; ConvF(4.82, 4.82, 4.82); Calibrated: 9/23/2013;

Sensor-Surface: 3mm (Mechanical Surface Detection)

Electronics: DAE4 Sn1323; Calibrated: 9/17/2013

Phantom: SAM with CRP; Type: SAM; Serial: TP1375

Measurement SW: DASY4, Version 4.7 (80); SEMCAD X Version 14.6.10 (7331)

1900MHz System Verification

Area Scan (5x7x1): Measurement grid: dx=15mm, dy=15mm

Zoom Scan (5x5x7)/Cube 0: Measurement grid: dx=8mm, dy=8mm, dz=5mm

Input Power = 20 dBm (100 mW)

Peak SAR (extrapolated) = 7.42 W/kg

SAR(1 g) = 4.21 W/kg

Deviation 7.12%

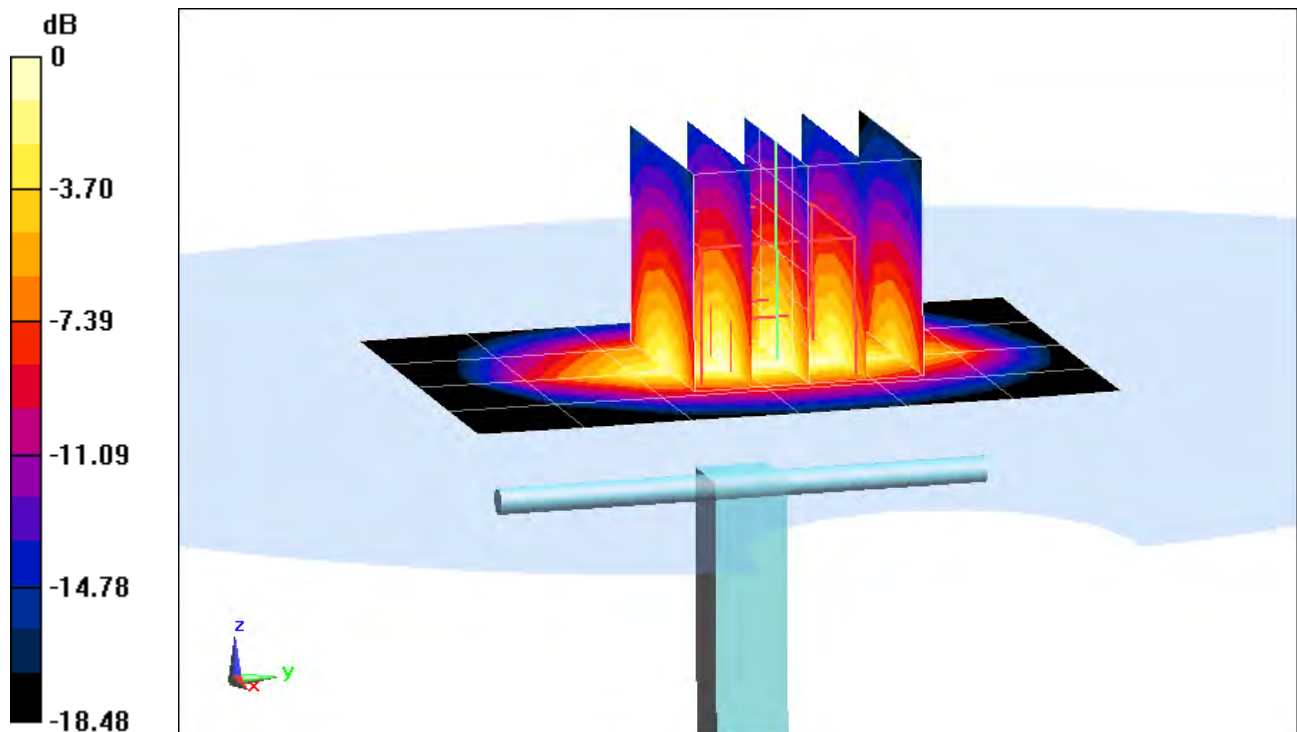

0 dB = 5.26 W/kg = 7.21 dBW/kg

PCTEST ENGINEERING LABORATORY, INC.

DUT: SAR Dipole 2450 MHz; Type: D2450V2; Serial: 797

Communication System: UID 0, CW; Frequency: 2450 MHz; Duty Cycle: 1:1

Medium: 2450 Body Medium parameters used:

$f = 2450 \text{ MHz}$; $\sigma = 1.97 \text{ S/m}$; $\epsilon_r = 51.945$; $\rho = 1000 \text{ kg/m}^3$

Phantom section: Flat Section; Space: 1.0 cm

Test Date: 08-18-2014; Ambient Temp: 24.5°C; Tissue Temp: 23.2°C

Probe: ES3DV3 - SN3319; ConvF(4.24, 4.24, 4.24); Calibrated: 4/17/2014;

Sensor-Surface: 3mm (Mechanical Surface Detection)

Electronics: DAE4 Sn1368; Calibrated: 4/11/2014

Phantom: ELI left; Type: QDOVA002AA; Serial: TP:1202

Measurement SW: DASYS2, Version 52.8 (8); SEMCAD X Version 14.6.10 (7331)

2450 MHz System Verification

Area Scan (8x9x1): Measurement grid: dx=12mm, dy=12mm

Zoom Scan (7x7x7)/Cube 0: Measurement grid: dx=5mm, dy=5mm, dz=5mm

Input Power = 20 dBm (100 mW)

Peak SAR (extrapolated) = 10.3 W/kg

SAR(1 g) = 4.93 W/kg

Deviation = -0.20%

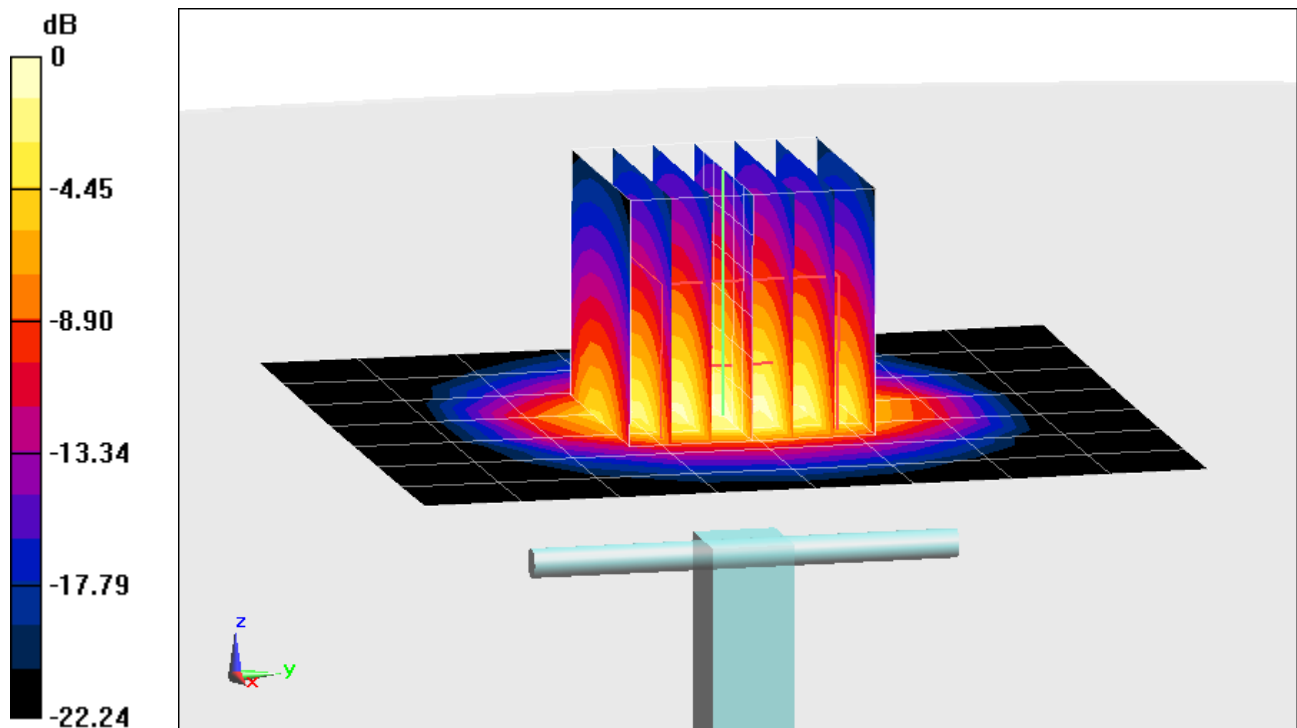

0 dB = 6.46 W/kg = 8.10 dBW/kg

PCTEST ENGINEERING LABORATORY, INC.

DUT: Dipole 5200 MHz; Type: D5GHzV2; Serial: 1007

Communication System: UID 0, CW; Frequency: 5200 MHz; Duty Cycle: 1:1

Medium: 5 GHz Body Medium parameters used:

$f = 5200 \text{ MHz}$; $\sigma = 5.106 \text{ S/m}$; $\epsilon_r = 47.285$; $\rho = 1000 \text{ kg/m}^3$

Phantom section: Flat Section; Space: 1.0 cm

Test Date: 08-18-2014; Ambient Temp: 23.4°C; Tissue Temp: 21.8°C

Probe: EX3DV4 - SN3920; ConvF(4.23, 4.23, 4.23); Calibrated: 12/18/2013;

Sensor-Surface: 1.4mm (Mechanical Surface Detection)

Electronics: DAE4 Sn649; Calibrated: 12/12/2013

Phantom: SAM Sub; Type: SAM 4.0; Serial: TP-1357

Measurement SW: DASY4, Version 4.7 (80); SEMCAD X Version 14.6.10 (7331)

5200MHz System Verification

Area Scan (7x9x1): Measurement grid: dx=10mm, dy=10mm

Zoom Scan (9x9x7)/Cube 0: Measurement grid: dx=4mm, dy=4mm, dz=1.4mm; Graded Ratio: 1.4

Input Power = 20 dBm (100 mW)

Peak SAR (extrapolated) = 27.9 W/kg

SAR(1 g) = 7.49 W/kg; SAR(10 g) = 2.13 W/kg

Deviation (1g) = 3.17%; Deviation (10g) = 5.45%

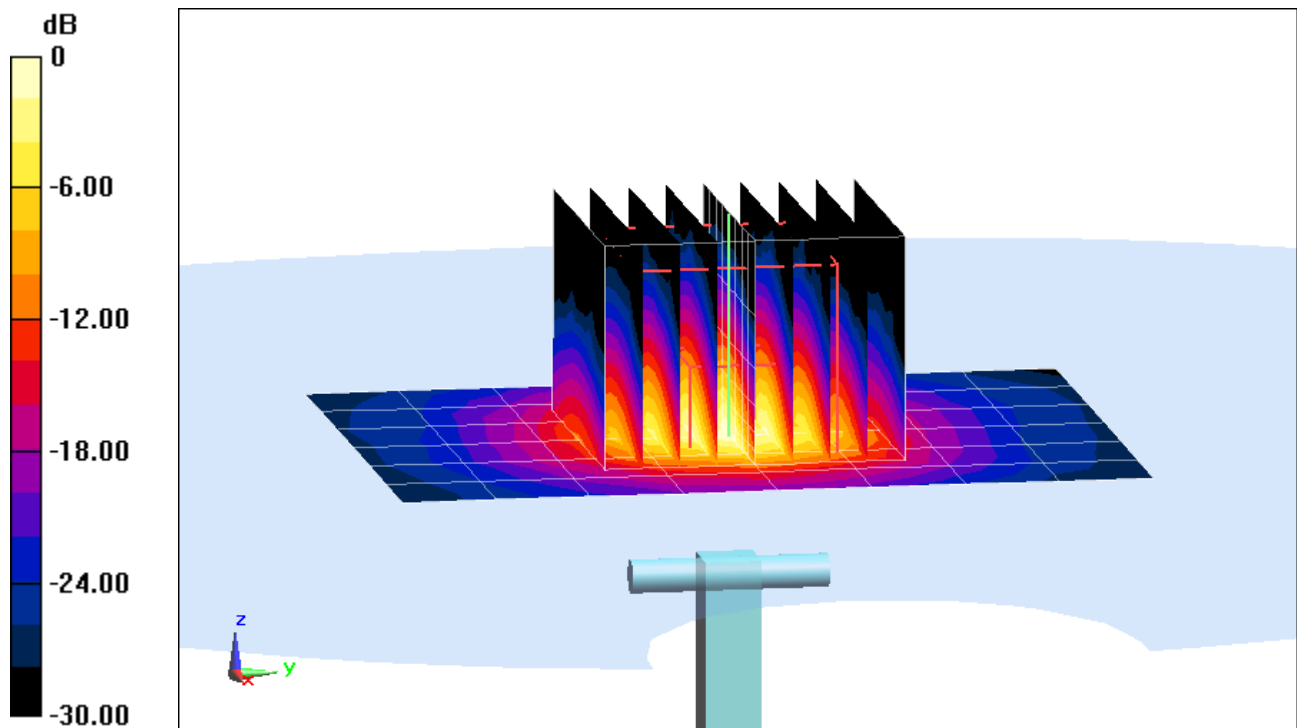

0 dB = 18.8 W/kg = 12.74 dBW/kg

PCTEST ENGINEERING LABORATORY, INC.

DUT: Dipole 5300 MHz; Type: D5GHzV2; Serial: 1007

Communication System: UID 0, CW; Frequency: 5300 MHz; Duty Cycle: 1:1

Medium: 5 GHz Body Medium parameters used:

$f = 5300 \text{ MHz}$; $\sigma = 5.228 \text{ S/m}$; $\epsilon_r = 47.061$; $\rho = 1000 \text{ kg/m}^3$

Phantom section: Flat Section; Space: 1.0 cm

Test Date: 08-18-2014; Ambient Temp: 23.4°C; Tissue Temp: 21.8°C

Probe: EX3DV4 - SN3920; ConvF(4.11, 4.11, 4.11); Calibrated: 12/18/2013;

Sensor-Surface: 1.4mm (Mechanical Surface Detection)

Electronics: DAE4 Sn649; Calibrated: 12/12/2013

Phantom: SAM Sub; Type: SAM 4.0; Serial: TP-1357

Measurement SW: DASY4, Version 4.7 (80); SEMCAD X Version 14.6.10 (7331)

5300MHz System Verification

Area Scan (7x9x1): Measurement grid: dx=10mm, dy=10mm

Zoom Scan (9x9x7)/Cube 0: Measurement grid: dx=4mm, dy=4mm, dz=1.4mm; Graded Ratio: 1.4

Input Power = 20 dBm (100 mW)

Peak SAR (extrapolated) = 28.9 W/kg

SAR(1 g) = 7.62 W/kg; SAR(10 g) = 2.13 W/kg

Deviation (1g) = 2.01%; Deviation (10g) = 2.40%

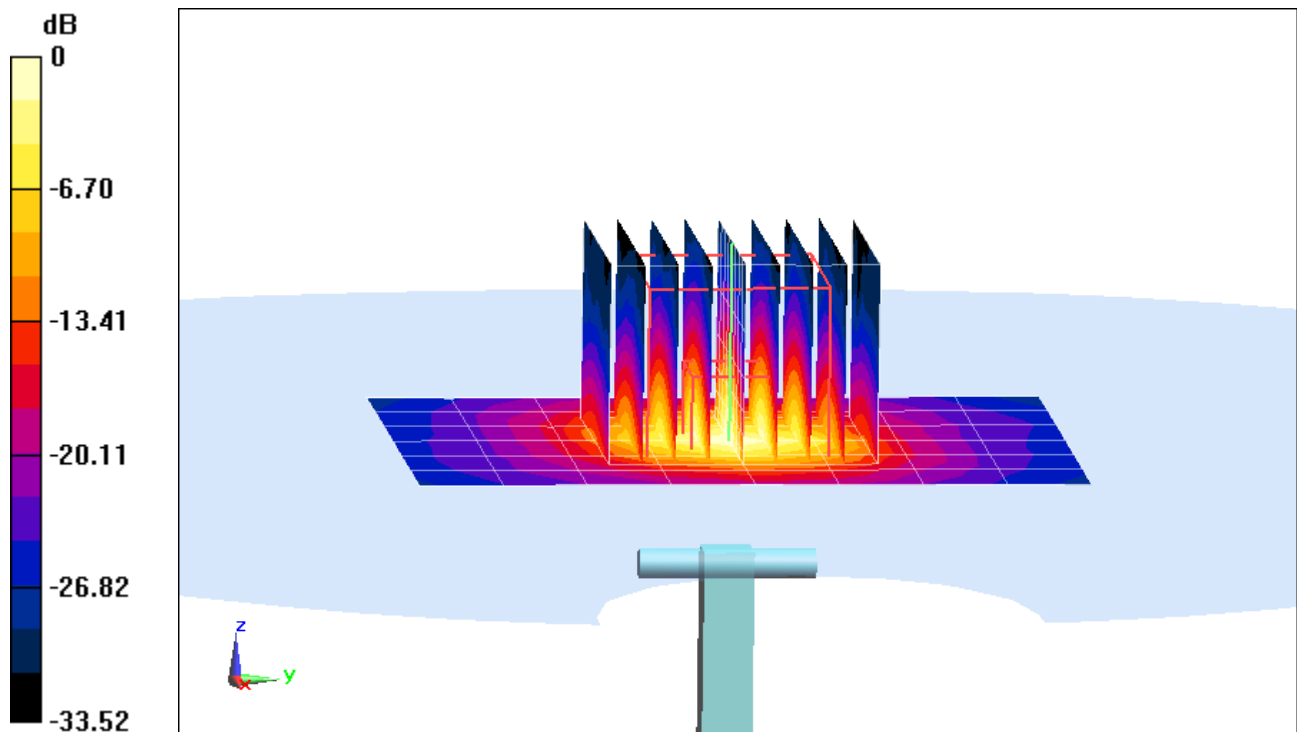

0 dB = 18.9 W/kg = 12.76 dBW/kg

PCTEST ENGINEERING LABORATORY, INC.

DUT: Dipole 5500 MHz; Type: D5GHzV2; Serial: 1007

Communication System: UID 0, CW; Frequency: 5500 MHz; Duty Cycle: 1:1

Medium: 5 GHz Body Medium parameters used:

$f = 5500 \text{ MHz}$; $\sigma = 5.509 \text{ S/m}$; $\epsilon_r = 46.844$; $\rho = 1000 \text{ kg/m}^3$

Phantom section: Flat Section; Space: 1.0 cm

Test Date: 08-18-2014; Ambient Temp: 23.4°C; Tissue Temp: 21.8°C

Probe: EX3DV4 - SN3920; ConvF(3.8, 3.8, 3.8); Calibrated: 12/18/2013;

Sensor-Surface: 1.4mm (Mechanical Surface Detection)

Electronics: DAE4 Sn649; Calibrated: 12/12/2013

Phantom: SAM Sub; Type: SAM 4.0; Serial: TP-1357

Measurement SW: DASY4, Version 4.7 (80); SEMCAD X Version 14.6.10 (7331)

5500MHz System Verification

Area Scan (7x9x1): Measurement grid: dx=10mm, dy=10mm

Zoom Scan (9x9x7)/Cube 0: Measurement grid: dx=4mm, dy=4mm, dz=1.4mm; Graded Ratio: 1.4

Input Power = 20 dBm (100 mW)

Peak SAR (extrapolated) = 32.3 W/kg

SAR(1 g) = 7.67 W/kg; SAR(10 g) = 2.16 W/kg

Deviation (1g) = 1.05%; Deviation (10g) = 2.86%

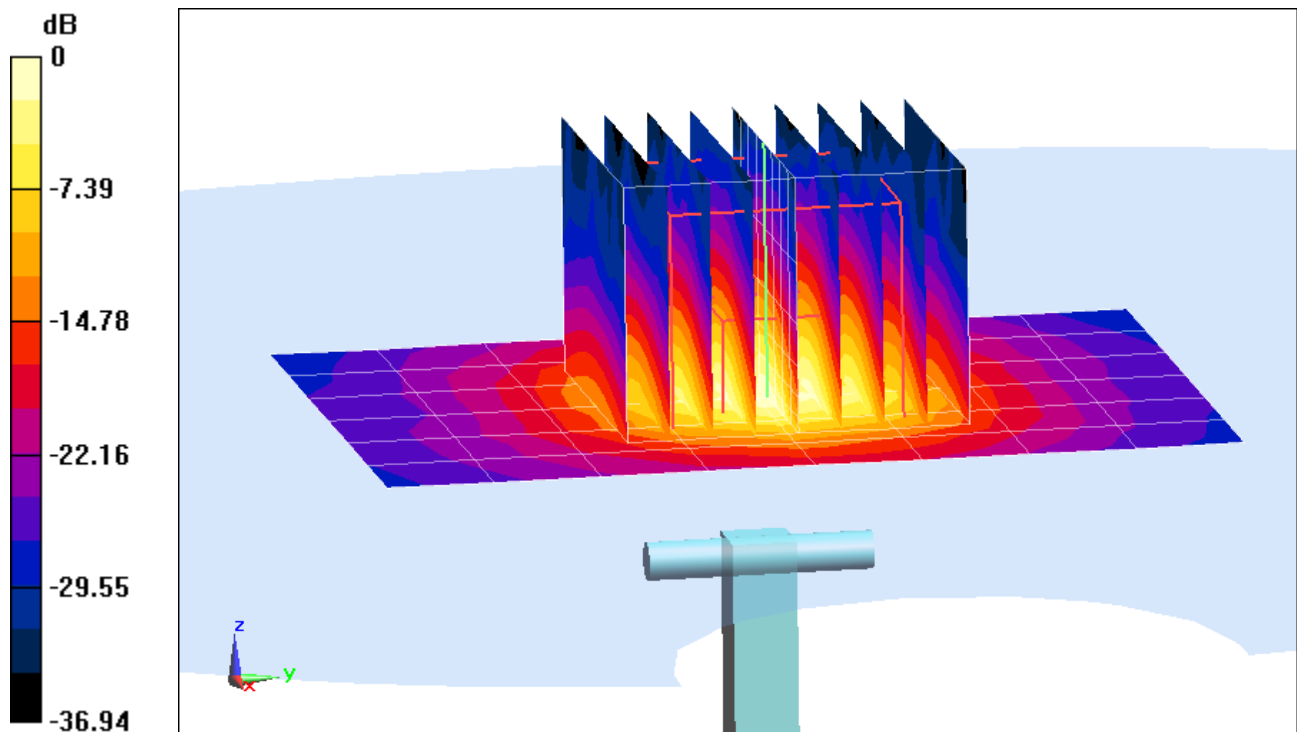

0 dB = 19.1 W/kg = 12.81 dBW/kg

PCTEST ENGINEERING LABORATORY, INC.

DUT: Dipole 5600 MHz; Type: D5GHzV2; Serial: 1007

Communication System: UID 0, CW; Frequency: 5600 MHz; Duty Cycle: 1:1

Medium: 5 GHz Body Medium parameters used:

$f = 5600 \text{ MHz}$; $\sigma = 5.653 \text{ S/m}$; $\epsilon_r = 46.714$; $\rho = 1000 \text{ kg/m}^3$

Phantom section: Flat Section; Space: 1.0 cm

Test Date: 08-18-2014; Ambient Temp: 23.4°C; Tissue Temp: 21.8°C

Probe: EX3DV4 - SN3920; ConvF(3.62, 3.62, 3.62); Calibrated: 12/18/2013;

Sensor-Surface: 1.4mm (Mechanical Surface Detection)

Electronics: DAE4 Sn649; Calibrated: 12/12/2013

Phantom: SAM Sub; Type: SAM 4.0; Serial: TP-1357

Measurement SW: DASY4, Version 4.7 (80); SEMCAD X Version 14.6.10 (7331)

5600MHz System Verification

Area Scan (7x9x1): Measurement grid: dx=10mm, dy=10mm

Zoom Scan (9x9x7)/Cube 0: Measurement grid: dx=4mm, dy=4mm, dz=1.4mm; Graded Ratio: 1.4

Input Power = 20 dBm (100 mW)

Peak SAR (extrapolated) = 32.6 W/kg

SAR(1 g) = 7.74 W/kg; SAR(10 g) = 2.17 W/kg

Deviation (1g) = 0.13%; Deviation (10g) = 0.93%

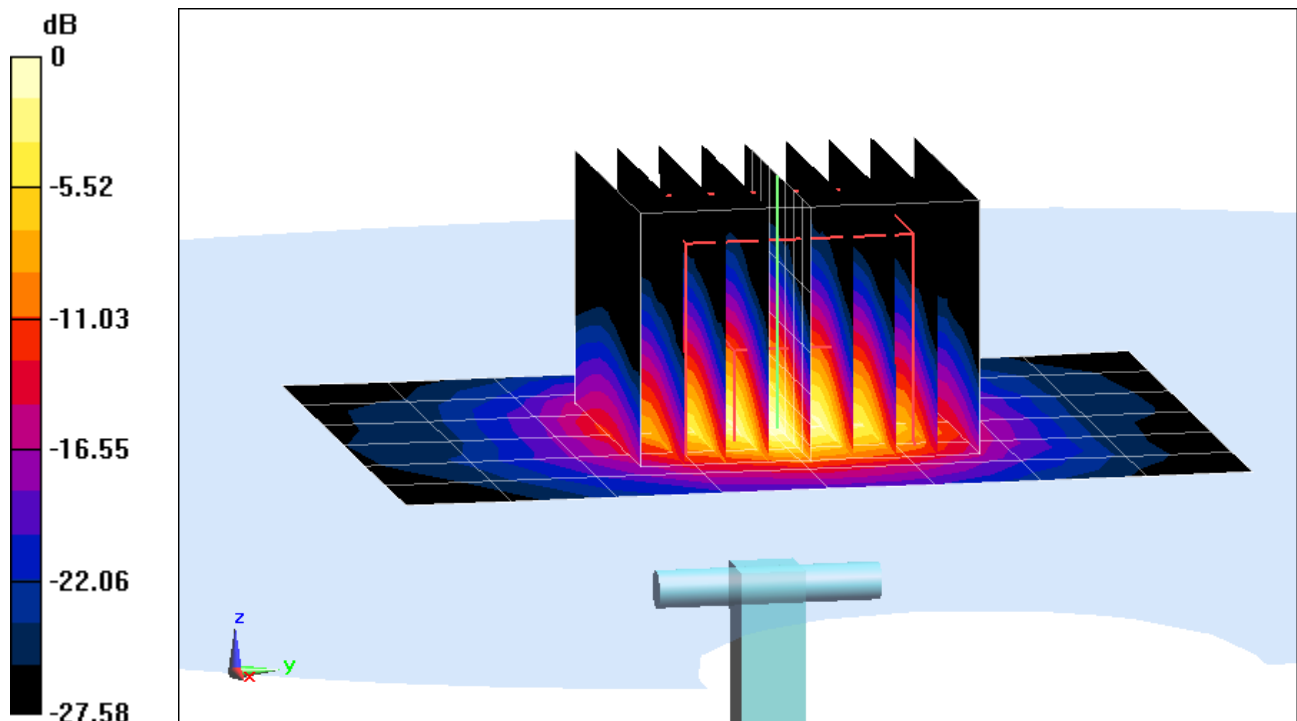

0 dB = 19.8 W/kg = 12.97 dBW/kg

PCTEST ENGINEERING LABORATORY, INC.

DUT: Dipole 5800 MHz; Type: D5GHzV2; Serial: 1007

Communication System: UID 0, CW; Frequency: 5800 MHz; Duty Cycle: 1:1

Medium: 5 GHz Body Medium parameters used:

$f = 5800 \text{ MHz}$; $\sigma = 5.842 \text{ S/m}$; $\epsilon_r = 46.461$; $\rho = 1000 \text{ kg/m}^3$

Phantom section: Flat Section; Space: 1.0 cm

Test Date: 08-18-2014; Ambient Temp: 23.4°C; Tissue Temp: 21.8°C

Probe: EX3DV4 - SN3920; ConvF(4, 4, 4); Calibrated: 12/18/2013;

Sensor-Surface: 1.4mm (Mechanical Surface Detection)

Electronics: DAE4 Sn649; Calibrated: 12/12/2013

Phantom: SAM Sub; Type: SAM 4.0; Serial: TP-1357

Measurement SW: DASY4, Version 4.7 (80); SEMCAD X Version 14.6.10 (7331)

5800MHz System Verification

Area Scan (7x9x1): Measurement grid: dx=10mm, dy=10mm

Zoom Scan (9x9x7)/Cube 0: Measurement grid: dx=4mm, dy=4mm, dz=1.4mm; Graded Ratio: 1.4

Input Power = 20 dBm (100 mW)

Peak SAR (extrapolated) = 32.5 W/kg

SAR(1 g) = 7.12 W/kg; SAR(10 g) = 1.96 W/kg

Deviation (1g) = -2.33; Deviation (10g) = -2.49%

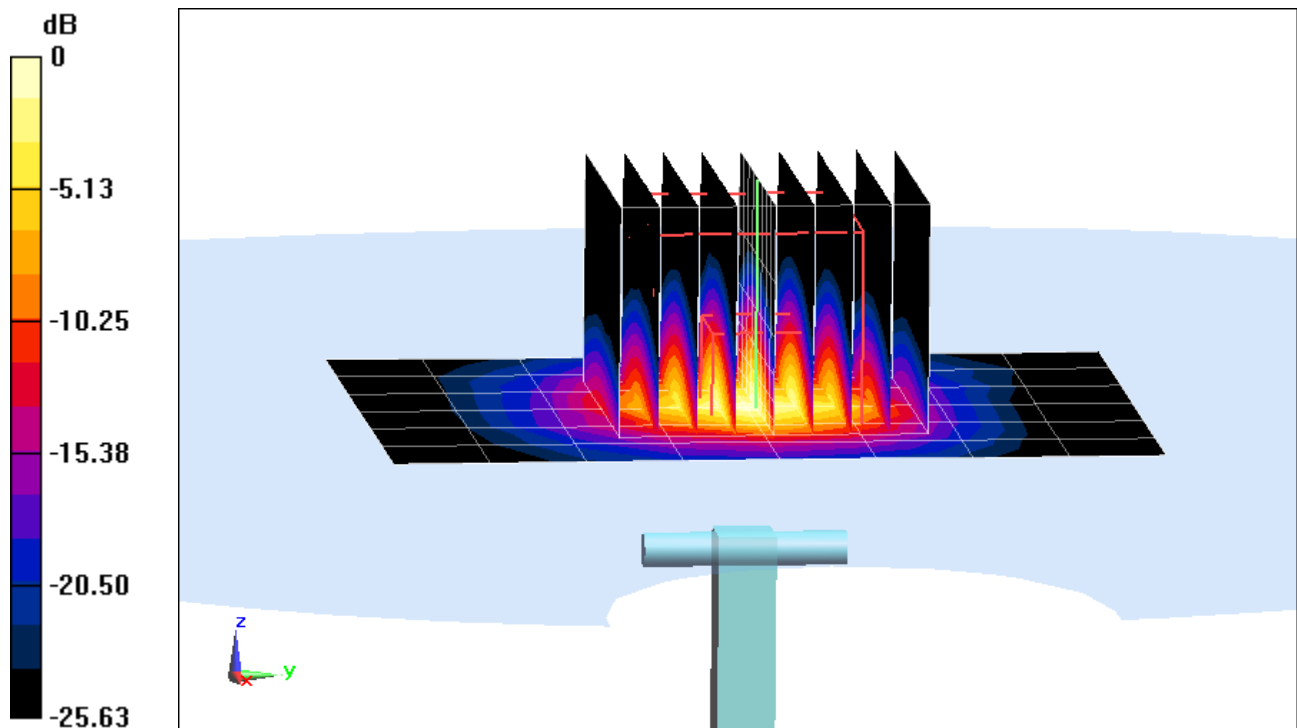

0 dB = 19.1 W/kg = 12.81 dBW/kg

APPENDIX C: PROBE CALIBRATION



Accredited by the Swiss Accreditation Service (SAS)
The Swiss Accreditation Service is one of the signatories to the EA
Multilateral Agreement for the recognition of calibration certificates

Accreditation No.: **SCS 108**

Client **PC Test**

Certificate No: **D1765V2-1008_May14**

CALIBRATION CERTIFICATE

Object **D1765V2 - SN: 1008**

Calibration procedure(s) **QA CAL-05.v9
Calibration procedure for dipole validation kits above 700 MHz**

*CCV
6/2/14*

Calibration date: **May 07, 2014**

This calibration certificate documents the traceability to national standards, which realize the physical units of measurements (SI).
The measurements and the uncertainties with confidence probability are given on the following pages and are part of the certificate.

All calibrations have been conducted in the closed laboratory facility: environment temperature (22 ± 3)°C and humidity < 70%.

Calibration Equipment used (M&TE critical for calibration)

Primary Standards	ID #	Cal Date (Certificate No.)	Scheduled Calibration
Power meter EPM-442A	GB37480704	09-Oct-13 (No. 217-01827)	Oct-14
Power sensor HP 8481A	US37292783	09-Oct-13 (No. 217-01827)	Oct-14
Power sensor HP 8481A	MY41092317	09-Oct-13 (No. 217-01828)	Oct-14
Reference 20 dB Attenuator	SN: 5058 (20k)	03-Apr-14 (No. 217-01918)	Apr-15
Type-N mismatch combination	SN: 5047.2 / 06327	03-Apr-14 (No. 217-01921)	Apr-15
Reference Probe ES3DV3	SN: 3205	30-Dec-13 (No. ES3-3205_Dec13)	Dec-14
DAE4	SN: 601	30-Apr-14 (No. DAE4-601_Apr14)	Apr-15
Secondary Standards	ID #	Check Date (in house)	Scheduled Check
RF generator R&S SMT-06	100005	04-Aug-99 (in house check Oct-13)	In house check: Oct-16
Network Analyzer HP 8753E	US37390585 S4206	18-Oct-01 (in house check Oct-13)	In house check: Oct-14

Calibrated by: **Name** Jeton Kastrati **Function** Laboratory Technician **Signature** *[Signature]*

Approved by: **Name** Katja Pokovic **Function** Technical Manager **Signature** *[Signature]*

Issued: May 12, 2014

This calibration certificate shall not be reproduced except in full without written approval of the laboratory.



Accredited by the Swiss Accreditation Service (SAS)
The Swiss Accreditation Service is one of the signatories to the EA
Multilateral Agreement for the recognition of calibration certificates

Accreditation No.: **SCS 108**

Glossary:

TSL	tissue simulating liquid
ConvF	sensitivity in TSL / NORM x,y,z
N/A	not applicable or not measured

Calibration is Performed According to the Following Standards:

- IEEE Std 1528-2013, "IEEE Recommended Practice for Determining the Peak Spatial-Averaged Specific Absorption Rate (SAR) in the Human Head from Wireless Communications Devices: Measurement Techniques", June 2013
- IEC 62209-1, "Procedure to measure the Specific Absorption Rate (SAR) for hand-held devices used in close proximity to the ear (frequency range of 300 MHz to 3 GHz)", February 2005
- KDB 865664, "SAR Measurement Requirements for 100 MHz to 6 GHz"

Additional Documentation:

- DASY4/5 System Handbook

Methods Applied and Interpretation of Parameters:

- Measurement Conditions:* Further details are available from the Validation Report at the end of the certificate. All figures stated in the certificate are valid at the frequency indicated.
- Antenna Parameters with TSL:* The dipole is mounted with the spacer to position its feed point exactly below the center marking of the flat phantom section, with the arms oriented parallel to the body axis.
- Feed Point Impedance and Return Loss:* These parameters are measured with the dipole positioned under the liquid filled phantom. The impedance stated is transformed from the measurement at the SMA connector to the feed point. The Return Loss ensures low reflected power. No uncertainty required.
- Electrical Delay:* One-way delay between the SMA connector and the antenna feed point. No uncertainty required.
- SAR measured:* SAR measured at the stated antenna input power.
- SAR normalized:* SAR as measured, normalized to an input power of 1 W at the antenna connector.
- SAR for nominal TSL parameters:* The measured TSL parameters are used to calculate the nominal SAR result.

The reported uncertainty of measurement is stated as the standard uncertainty of measurement multiplied by the coverage factor $k=2$, which for a normal distribution corresponds to a coverage probability of approximately 95%.

Measurement Conditions

DASY system configuration, as far as not given on page 1.

DASY Version	DASY5	V52.8.8
Extrapolation	Advanced Extrapolation	
Phantom	Modular Flat Phantom	
Distance Dipole Center - TSL	10 mm	with Spacer
Zoom Scan Resolution	dx, dy, dz = 5 mm	
Frequency	1750 MHz \pm 1 MHz	

Head TSL parameters

The following parameters and calculations were applied.

	Temperature	Permittivity	Conductivity
Nominal Head TSL parameters	22.0 °C	40.1	1.37 mho/m
Measured Head TSL parameters	(22.0 \pm 0.2) °C	39.0 \pm 6 %	1.36 mho/m \pm 6 %
Head TSL temperature change during test	< 0.5 °C	----	----

SAR result with Head TSL

SAR averaged over 1 cm ³ (1 g) of Head TSL	Condition	
SAR measured	250 mW input power	9.23 W/kg
SAR for nominal Head TSL parameters	normalized to 1W	36.9 W/kg \pm 17.0 % (k=2)

SAR averaged over 10 cm ³ (10 g) of Head TSL	condition	
SAR measured	250 mW input power	4.87 W/kg
SAR for nominal Head TSL parameters	normalized to 1W	19.5 W/kg \pm 16.5 % (k=2)

Body TSL parameters

The following parameters and calculations were applied.

	Temperature	Permittivity	Conductivity
Nominal Body TSL parameters	22.0 °C	53.4	1.49 mho/m
Measured Body TSL parameters	(22.0 \pm 0.2) °C	52.2 \pm 6 %	1.48 mho/m \pm 6 %
Body TSL temperature change during test	< 0.5 °C	----	----

SAR result with Body TSL

SAR averaged over 1 cm ³ (1 g) of Body TSL	Condition	
SAR measured	250 mW input power	9.41 W/kg
SAR for nominal Body TSL parameters	normalized to 1W	37.6 W/kg \pm 17.0 % (k=2)

SAR averaged over 10 cm ³ (10 g) of Body TSL	condition	
SAR measured	250 mW input power	5.02 W/kg
SAR for nominal Body TSL parameters	normalized to 1W	20.1 W/kg \pm 16.5 % (k=2)

Appendix

Antenna Parameters with Head TSL

Impedance, transformed to feed point	47.7 Ω - 6.1 j Ω
Return Loss	- 23.6 dB

Antenna Parameters with Body TSL

Impedance, transformed to feed point	43.7 Ω - 6.4 j Ω
Return Loss	- 20.4 dB

General Antenna Parameters and Design

Electrical Delay (one direction)	1.211 ns
----------------------------------	----------

After long term use with 100W radiated power, only a slight warming of the dipole near the feedpoint can be measured.

The dipole is made of standard semirigid coaxial cable. The center conductor of the feeding line is directly connected to the second arm of the dipole. The antenna is therefore short-circuited for DC-signals. On some of the dipoles, small end caps are added to the dipole arms in order to improve matching when loaded according to the position as explained in the "Measurement Conditions" paragraph. The SAR data are not affected by this change. The overall dipole length is still according to the Standard.

No excessive force must be applied to the dipole arms, because they might bend or the soldered connections near the feedpoint may be damaged.

Additional EUT Data

Manufactured by	SPEAG
Manufactured on	October 06, 2005

DASY5 Validation Report for Head TSL

Date: 07.05.2014

Test Laboratory: SPEAG, Zurich, Switzerland

DUT: Dipole 1765 MHz; Type: D1765V2; Serial: D1765V2 - SN: 1008

Communication System: UID 0 - CW; Frequency: 1750 MHz

Medium parameters used: $f = 1750$ MHz; $\sigma = 1.36$ S/m; $\epsilon_r = 39$; $\rho = 1000$ kg/m³

Phantom section: Flat Section

Measurement Standard: DASY5 (IEEE/IEC/ANSI C63.19-2007)

DASY52 Configuration:

- Probe: ES3DV3 - SN3205; ConvF(5.23, 5.23, 5.23); Calibrated: 30.12.2013;
- Sensor-Surface: 3mm (Mechanical Surface Detection)
- Electronics: DAE4 Sn601; Calibrated: 30.04.2014
- Phantom: Flat Phantom 5.0 (front); Type: QD000P50AA; Serial: 1001
- DASY52 52.8.8(1222); SEMCAD X 14.6.10(7331)

Dipole Calibration for Head Tissue/Pin=250 mW, d=10mm/Zoom Scan (7x7x7)/Cube 0:

Measurement grid: dx=5mm, dy=5mm, dz=5mm

Reference Value = 96.06 V/m; Power Drift = 0.01 dB

Peak SAR (extrapolated) = 16.7 W/kg

SAR(1 g) = 9.23 W/kg; SAR(10 g) = 4.87 W/kg

Maximum value of SAR (measured) = 11.7 W/kg

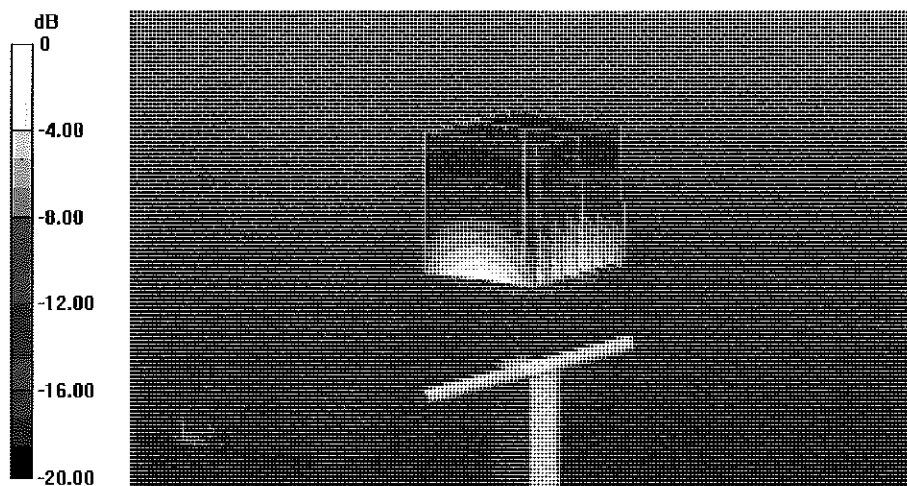

0 dB = 11.7 W/kg = 10.68 dBW/kg

Impedance Measurement Plot for Head TSL

7 May 2014 09:22:35

CH1 S11 1 U FS 1: 47.709 Ω -6.0566 Ω 15.016 pF 1 750.000 000 MHz

*
De1

CΔ

Avg
16

H1 d

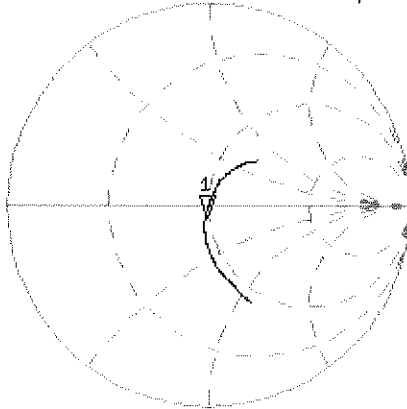

CH2 S11 LOG 5 dB/REF -20 dB 1:-23.588 dB 1 750.000 000 MHz

CΔ

Avg
16

H1 d

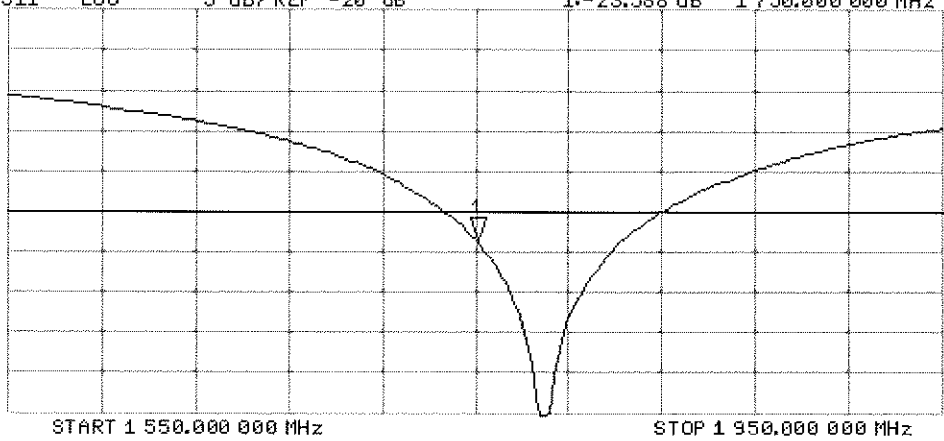

DASY5 Validation Report for Body TSL

Date: 07.05.2014

Test Laboratory: SPEAG, Zurich, Switzerland

DUT: Dipole 1765 MHz; Type: D1765V2; Serial: D1765V2 - SN: 1008

Communication System: UID 0 - CW; Frequency: 1750 MHz

Medium parameters used: $f = 1750$ MHz; $\sigma = 1.48$ S/m; $\epsilon_r = 52.2$; $\rho = 1000$ kg/m³

Phantom section: Flat Section

Measurement Standard: DASY5 (IEEE/IEC/ANSI C63.19-2007)

DASY52 Configuration:

- Probe: ES3DV3 - SN3205; ConvF(4.89, 4.89, 4.89); Calibrated: 30.12.2013;
- Sensor-Surface: 3mm (Mechanical Surface Detection)
- Electronics: DAE4 Sn601; Calibrated: 30.04.2014
- Phantom: Flat Phantom 5.0 (back); Type: QD000P50AA; Serial: 1002
- DASY52 52.8.8(1222); SEMCAD X 14.6.10(7331)

Dipole Calibration for Body Tissue/Pin=250 mW, d=10mm/Zoom Scan (7x7x7)/Cube 0:

Measurement grid: dx=5mm, dy=5mm, dz=5mm

Reference Value = 93.01 V/m; Power Drift = 0.00 dB

Peak SAR (extrapolated) = 16.3 W/kg

SAR(1 g) = 9.41 W/kg; SAR(10 g) = 5.02 W/kg

Maximum value of SAR (measured) = 11.8 W/kg

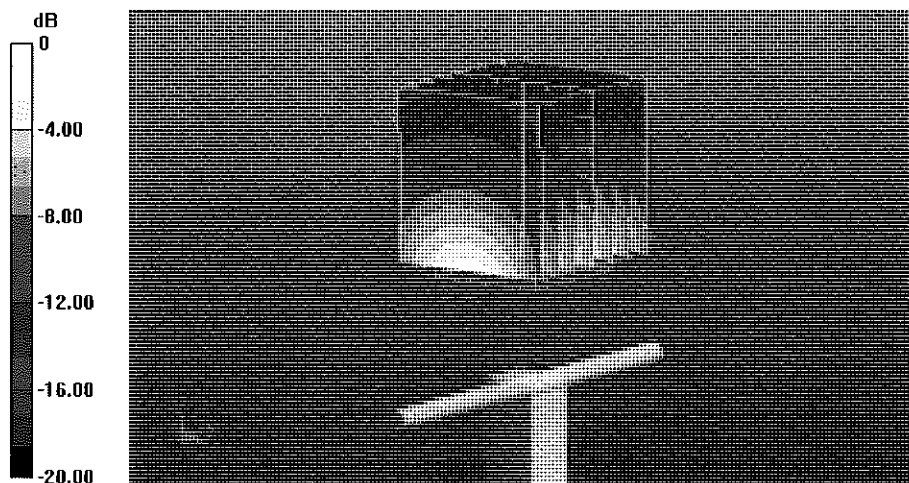

0 dB = 11.8 W/kg = 10.72 dBW/kg

Impedance Measurement Plot for Body TSL

7 May 2014 09:21:55

CH1 S11 1 U FS 1: 43.727 Ω -5.3691 Ω 14.279 pF 1 750.000 000 MHz

*
De1

CA

Avg
16

H1d

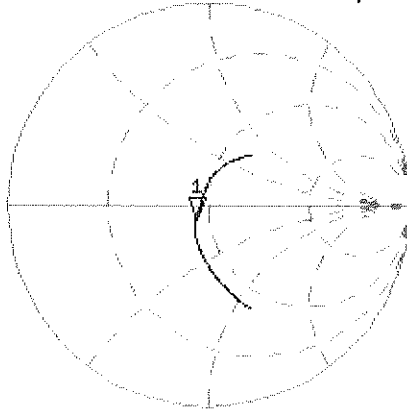

CH2 S11 LOG 5 dB/REF -20 dB 1:-20.428 dB 1 750.000 000 MHz

CA

Avg
16

H1d

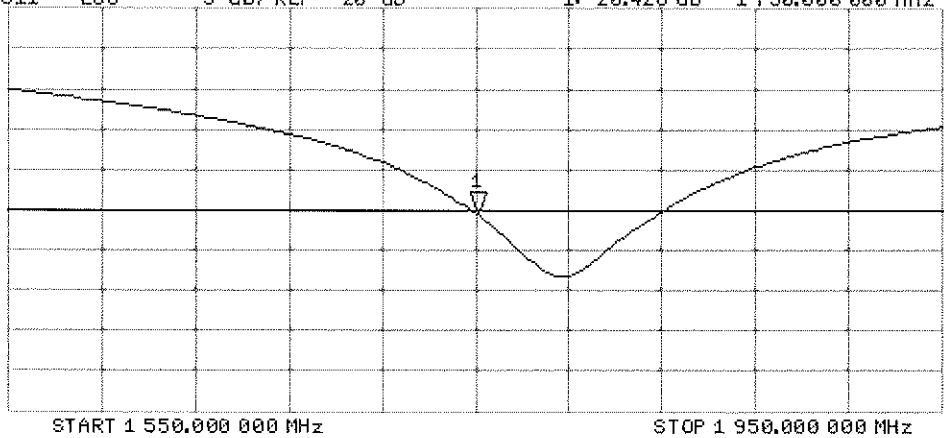



Accredited by the Swiss Accreditation Service (SAS)
The Swiss Accreditation Service is one of the signatories to the EA
Multilateral Agreement for the recognition of calibration certificates

Accreditation No.: **SCS 108**

Client **PC Test**

Certificate No: **D1900V2-5d141_Apr14**

CALIBRATION CERTIFICATE

Object **D1900V2 - SN: 5d141**

Calibration procedure(s) **QA CAL-05.v9**
Calibration procedure for dipole validation kits above 700 MHz

Calibration date: **April 09, 2014**

✓
KOK
5/7/14

This calibration certificate documents the traceability to national standards, which realize the physical units of measurements (SI).
The measurements and the uncertainties with confidence probability are given on the following pages and are part of the certificate.

All calibrations have been conducted in the closed laboratory facility: environment temperature (22 ± 3)°C and humidity < 70%.

Calibration Equipment used (M&TE critical for calibration)

Primary Standards	ID #	Cal Date (Certificate No.)	Scheduled Calibration
Power meter EPM-442A	GB37480704	09-Oct-13 (No. 217-01827)	Oct-14
Power sensor HP 8481A	US37292783	09-Oct-13 (No. 217-01827)	Oct-14
Power sensor HP 8481A	MY41092317	09-Oct-13 (No. 217-01828)	Oct-14
Reference 20 dB Attenuator	SN: 5058 (20k)	03-Apr-14 (No. 217-01918)	Apr-15
Type-N mismatch combination	SN: 5047.2 / 06327	03-Apr-14 (No. 217-01921)	Apr-15
Reference Probe ES3DV3	SN: 3205	30-Dec-13 (No. ES3-3205_Dec13)	Dec-14
DAE4	SN: 601	25-Apr-13 (No. DAE4-601_Apr13)	Apr-14
Secondary Standards	ID #	Check Date (in house)	Scheduled Check
RF generator R&S SMT-06	100005	04-Aug-99 (in house check Oct-13)	In house check: Oct-16
Network Analyzer HP 8753E	US37390585 S4206	18-Oct-01 (in house check Oct-13)	In house check: Oct-14

Calibrated by: **Claudio Leubler** Name: Claudio Leubler Function: Laboratory Technician

Approved by: **Katja Pokovic** Name: Katja Pokovic Function: Technical Manager

Signature

Issued: April 9, 2014

This calibration certificate shall not be reproduced except in full without written approval of the laboratory.



Accredited by the Swiss Accreditation Service (SAS)
The Swiss Accreditation Service is one of the signatories to the EA
Multilateral Agreement for the recognition of calibration certificates

Accreditation No.: **SCS 108**

Glossary:

TSL	tissue simulating liquid
ConvF	sensitivity in TSL / NORM x,y,z
N/A	not applicable or not measured

Calibration is Performed According to the Following Standards:

- IEEE Std 1528-2013, "IEEE Recommended Practice for Determining the Peak Spatial-Averaged Specific Absorption Rate (SAR) in the Human Head from Wireless Communications Devices: Measurement Techniques", June 2013
- IEC 62209-1, "Procedure to measure the Specific Absorption Rate (SAR) for hand-held devices used in close proximity to the ear (frequency range of 300 MHz to 3 GHz)", February 2005
- KDB 865664, "SAR Measurement Requirements for 100 MHz to 6 GHz"

Additional Documentation:

- DASY4/5 System Handbook

Methods Applied and Interpretation of Parameters:

- Measurement Conditions:* Further details are available from the Validation Report at the end of the certificate. All figures stated in the certificate are valid at the frequency indicated.
- Antenna Parameters with TSL:* The dipole is mounted with the spacer to position its feed point exactly below the center marking of the flat phantom section, with the arms oriented parallel to the body axis.
- Feed Point Impedance and Return Loss:* These parameters are measured with the dipole positioned under the liquid filled phantom. The impedance stated is transformed from the measurement at the SMA connector to the feed point. The Return Loss ensures low reflected power. No uncertainty required.
- Electrical Delay:* One-way delay between the SMA connector and the antenna feed point. No uncertainty required.
- SAR measured:* SAR measured at the stated antenna input power.
- SAR normalized:* SAR as measured, normalized to an input power of 1 W at the antenna connector.
- SAR for nominal TSL parameters:* The measured TSL parameters are used to calculate the nominal SAR result.

The reported uncertainty of measurement is stated as the standard uncertainty of measurement multiplied by the coverage factor $k=2$, which for a normal distribution corresponds to a coverage probability of approximately 95%.

Measurement Conditions

DASY system configuration, as far as not given on page 1.

DASY Version	DASY5	V52.8.7
Extrapolation	Advanced Extrapolation	
Phantom	Modular Flat Phantom	
Distance Dipole Center - TSL	10 mm	with Spacer
Zoom Scan Resolution	dx, dy, dz = 5 mm	
Frequency	1900 MHz \pm 1 MHz	

Head TSL parameters

The following parameters and calculations were applied.

	Temperature	Permittivity	Conductivity
Nominal Head TSL parameters	22.0 °C	40.0	1.40 mho/m
Measured Head TSL parameters	(22.0 \pm 0.2) °C	39.1 \pm 6 %	1.36 mho/m \pm 6 %
Head TSL temperature change during test	< 0.5 °C	----	----

SAR result with Head TSL

SAR averaged over 1 cm ³ (1 g) of Head TSL	Condition	
SAR measured	250 mW input power	9.91 W/kg
SAR for nominal Head TSL parameters	normalized to 1W	40.1 W/kg \pm 17.0 % (k=2)

SAR averaged over 10 cm ³ (10 g) of Head TSL	condition	
SAR measured	250 mW input power	5.17 W/kg
SAR for nominal Head TSL parameters	normalized to 1W	20.8 W/kg \pm 16.5 % (k=2)

Body TSL parameters

The following parameters and calculations were applied.

	Temperature	Permittivity	Conductivity
Nominal Body TSL parameters	22.0 °C	53.3	1.52 mho/m
Measured Body TSL parameters	(22.0 \pm 0.2) °C	52.4 \pm 6 %	1.52 mho/m \pm 6 %
Body TSL temperature change during test	< 0.5 °C	----	----

SAR result with Body TSL

SAR averaged over 1 cm ³ (1 g) of Body TSL	Condition	
SAR measured	250 mW input power	10.2 W/kg
SAR for nominal Body TSL parameters	normalized to 1W	40.6 W/kg \pm 17.0 % (k=2)

SAR averaged over 10 cm ³ (10 g) of Body TSL	condition	
SAR measured	250 mW input power	5.41 W/kg
SAR for nominal Body TSL parameters	normalized to 1W	21.6 W/kg \pm 16.5 % (k=2)

Appendix

Antenna Parameters with Head TSL

Impedance, transformed to feed point	$52.8 \Omega + 5.5 j\Omega$
Return Loss	- 24.5 dB

Antenna Parameters with Body TSL

Impedance, transformed to feed point	$48.8 \Omega + 6.3 j\Omega$
Return Loss	- 23.7 dB

General Antenna Parameters and Design

Electrical Delay (one direction)	1.199 ns
----------------------------------	----------

After long term use with 100W radiated power, only a slight warming of the dipole near the feedpoint can be measured.

The dipole is made of standard semirigid coaxial cable. The center conductor of the feeding line is directly connected to the second arm of the dipole. The antenna is therefore short-circuited for DC-signals. On some of the dipoles, small end caps are added to the dipole arms in order to improve matching when loaded according to the position as explained in the "Measurement Conditions" paragraph. The SAR data are not affected by this change. The overall dipole length is still according to the Standard.

No excessive force must be applied to the dipole arms, because they might bend or the soldered connections near the feedpoint may be damaged.

Additional EUT Data

Manufactured by	SPEAG
Manufactured on	March 11, 2011

DASY5 Validation Report for Head TSL

Date: 09.04.2014

Test Laboratory: SPEAG, Zurich, Switzerland

DUT: Dipole 1900 MHz; Type: D1900V2; Serial: D1900V2 - SN: 5d141

Communication System: UID 0 - CW; Frequency: 1900 MHz

Medium parameters used: $f = 1900$ MHz; $\sigma = 1.36$ S/m; $\epsilon_r = 39.1$; $\rho = 1000$ kg/m³

Phantom section: Flat Section

Measurement Standard: DASY5 (IEEE/IEC/ANSI C63.19-2007)

DASY52 Configuration:

- Probe: ES3DV3 - SN3205; ConvF(5.06, 5.06, 5.06); Calibrated: 30.12.2013;
- Sensor-Surface: 3mm (Mechanical Surface Detection)
- Electronics: DAE4 Sn601; Calibrated: 25.04.2013
- Phantom: Flat Phantom 5.0 (front); Type: QD000P50AA; Serial: 1001
- DASY52 52.8.7(1137); SEMCAD X 14.6.10(7164)

Dipole Calibration for Head Tissue/Pin=250 mW, d=10mm/Zoom Scan (7x7x7)/Cube 0:

Measurement grid: dx=5mm, dy=5mm, dz=5mm

Reference Value = 99.080 V/m; Power Drift = 0.01 dB

Peak SAR (extrapolated) = 18.2 W/kg

SAR(1 g) = 9.91 W/kg; SAR(10 g) = 5.17 W/kg

Maximum value of SAR (measured) = 12.5 W/kg

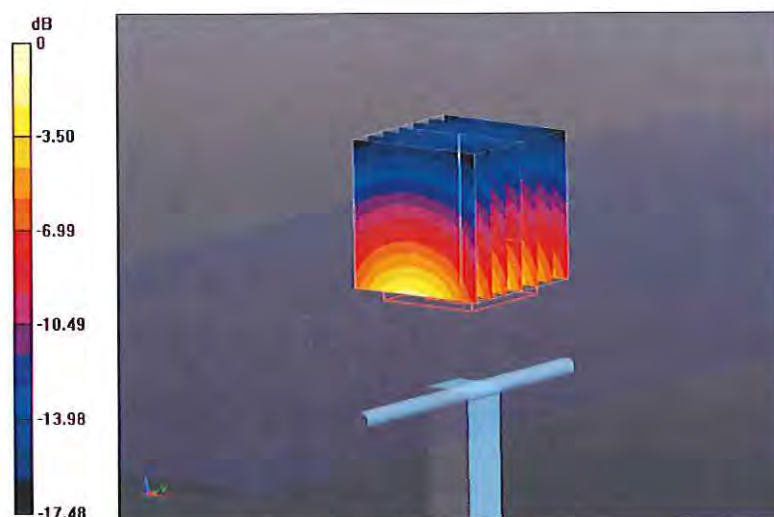

0 dB = 12.5 W/kg = 10.97 dBW/kg

Impedance Measurement Plot for Head TSL

9 Apr 2014 11:03:32

CH1 S11 1 U FS 1: 52.760 Ω 5.4512 Ω 456.62 pF 1 900.000 000 MHz

*
De1
CA

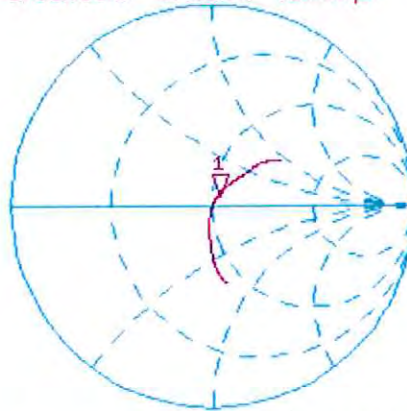

Avg
16

H1 d

CH2 S11 LOG 5 dB/REF -20 dB 1:-24.525 dB 1 900.000 000 MHz

CA

Avg
16

H1 d

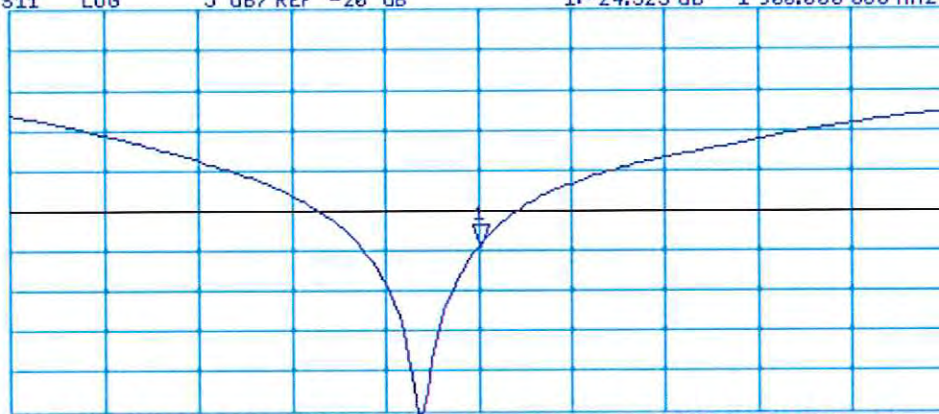

START 1 700.000 000 MHz

STOP 2 100.000 000 MHz

DASY5 Validation Report for Body TSL

Date: 09.04.2014

Test Laboratory: SPEAG, Zurich, Switzerland

DUT: Dipole 1900 MHz; Type: D1900V2; Serial: D1900V2 - SN: 5d141

Communication System: UID 0 - CW; Frequency: 1900 MHz

Medium parameters used: $f = 1900$ MHz; $\sigma = 1.52$ S/m; $\epsilon_r = 52.4$; $\rho = 1000$ kg/m³

Phantom section: Flat Section

Measurement Standard: DASY5 (IEEE/IEC/ANSI C63.19-2007)

DASY52 Configuration:

- Probe: ES3DV3 - SN3205; ConvF(4.76, 4.76, 4.76); Calibrated: 30.12.2013;
- Sensor-Surface: 3mm (Mechanical Surface Detection)
- Electronics: DAE4 Sn601; Calibrated: 25.04.2013
- Phantom: Flat Phantom 5.0 (back); Type: QD000P50AA; Serial: 1002
- DASY52 52.8.7(1137); SEMCAD X 14.6.10(7164)

Dipole Calibration for Body Tissue/Pin=250 mW, d=10mm/Zoom Scan (7x7x7)/Cube 0:

Measurement grid: dx=5mm, dy=5mm, dz=5mm

Reference Value = 95.820 V/m; Power Drift = -0.01 dB

Peak SAR (extrapolated) = 17.9 W/kg

SAR(1 g) = 10.2 W/kg; SAR(10 g) = 5.41 W/kg

Maximum value of SAR (measured) = 12.9 W/kg

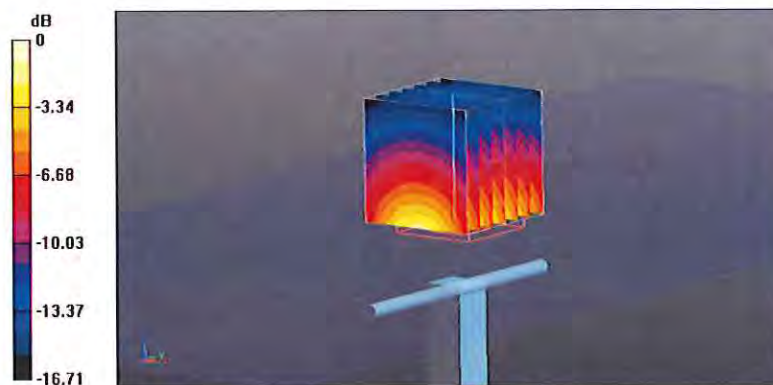

0 dB = 12.9 W/kg = 11.11 dBW/kg

Impedance Measurement Plot for Body TSL

9 Apr 2014 11:02:32

CH1 S11 1 U FS 1: 48.752 Ω 6.3320 Ω 530.41 pF 1 900.000 000 MHz

*
Del
CA

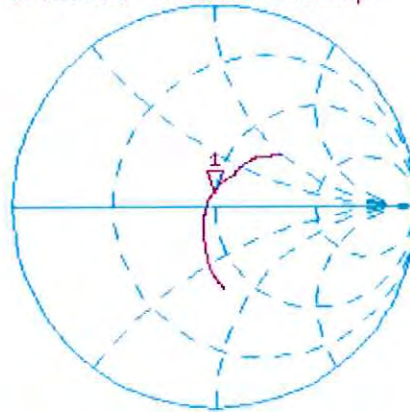

Avg
16
↑

CH2 S11 LOG 5 dB/REF -20 dB 1:-23.715 dB 1 900.000 000 MHz

CA
Avg
16
↑

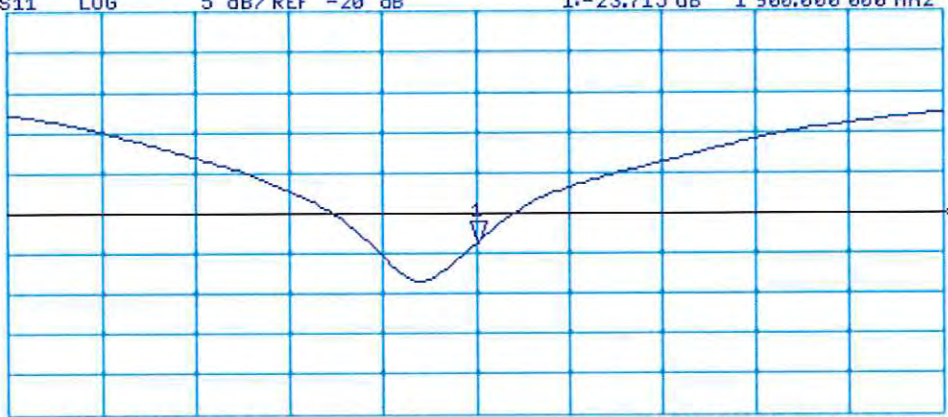

START 1 700.000 000 MHz

STOP 2 100.000 000 MHz



Accredited by the Swiss Accreditation Service (SAS)
The Swiss Accreditation Service is one of the signatories to the EA
Multilateral Agreement for the recognition of calibration certificates

Accreditation No.: **SCS 108**

Client **PC Test**

Certificate No: **D1900V2-5d148_Feb14**

CALIBRATION CERTIFICATE

Object **D1900V2 - SN: 5d148**

Calibration procedure(s) **QA CAL-05.v9**
Calibration procedure for dipole validation kits above 700 MHz

Calibration date: **February 27, 2014**

*CCV
27/2/2014*

This calibration certificate documents the traceability to national standards, which realize the physical units of measurements (SI).
The measurements and the uncertainties with confidence probability are given on the following pages and are part of the certificate.

All calibrations have been conducted in the closed laboratory facility: environment temperature (22 ± 3)°C and humidity < 70%.

Calibration Equipment used (M&TE critical for calibration)

Primary Standards	ID #	Cal Date (Certificate No.)	Scheduled Calibration
Power meter EPM-442A	GB37480704	09-Oct-13 (No. 217-01827)	Oct-14
Power sensor HP 8481A	US37292783	09-Oct-13 (No. 217-01827)	Oct-14
Power sensor HP 8481A	MY41092317	09-Oct-13 (No. 217-01828)	Oct-14
Reference 20 dB Attenuator	SN: 5058 (20k)	04-Apr-13 (No. 217-01736)	Apr-14
Type-N mismatch combination	SN: 5047.3 / 06327	04-Apr-13 (No. 217-01739)	Apr-14
Reference Probe ES3DV3	SN: 3205	30-Dec-13 (No. ES3-3205_Dec13)	Dec-14
DAE4	SN: 601	25-Apr-13 (No. DAE4-601_Apr13)	Apr-14
Secondary Standards	ID #	Check Date (in house)	Scheduled Check
RF generator R&S SMT-06	100005	04-Aug-99 (in house check Oct-13)	In house check: Oct-16
Network Analyzer HP 8753E	US37390585 S4206	18-Oct-01 (in house check Oct-13)	In house check: Oct-14

Calibrated by: **Jeton Kastrati** (Name) / **Laboratory Technician** (Function) / *[Signature]* (Signature)

Approved by: **Katja Pokovic** (Name) / **Technical Manager** (Function) / *[Signature]* (Signature)

Issued: February 27, 2014

This calibration certificate shall not be reproduced except in full without written approval of the laboratory.



Accredited by the Swiss Accreditation Service (SAS)

The Swiss Accreditation Service is one of the signatories to the EA Multilateral Agreement for the recognition of calibration certificates

Accreditation No.: **SCS 108**

Glossary:

TSL	tissue simulating liquid
ConvF	sensitivity in TSL / NORM x,y,z
N/A	not applicable or not measured

Calibration is Performed According to the Following Standards:

- IEEE Std 1528-2013, "IEEE Recommended Practice for Determining the Peak Spatial-Averaged Specific Absorption Rate (SAR) in the Human Head from Wireless Communications Devices: Measurement Techniques", June 2013
- IEC 62209-1, "Procedure to measure the Specific Absorption Rate (SAR) for hand-held devices used in close proximity to the ear (frequency range of 300 MHz to 3 GHz)", February 2005
- KDB 865664, "SAR Measurement Requirements for 100 MHz to 6 GHz"

Additional Documentation:

- DASY4/5 System Handbook

Methods Applied and Interpretation of Parameters:

- Measurement Conditions:* Further details are available from the Validation Report at the end of the certificate. All figures stated in the certificate are valid at the frequency indicated.
- Antenna Parameters with TSL:* The dipole is mounted with the spacer to position its feed point exactly below the center marking of the flat phantom section, with the arms oriented parallel to the body axis.
- Feed Point Impedance and Return Loss:* These parameters are measured with the dipole positioned under the liquid filled phantom. The impedance stated is transformed from the measurement at the SMA connector to the feed point. The Return Loss ensures low reflected power. No uncertainty required.
- Electrical Delay:* One-way delay between the SMA connector and the antenna feed point. No uncertainty required.
- SAR measured:* SAR measured at the stated antenna input power.
- SAR normalized:* SAR as measured, normalized to an input power of 1 W at the antenna connector.
- SAR for nominal TSL parameters:* The measured TSL parameters are used to calculate the nominal SAR result.

The reported uncertainty of measurement is stated as the standard uncertainty of measurement multiplied by the coverage factor $k=2$, which for a normal distribution corresponds to a coverage probability of approximately 95%.

Measurement Conditions

DASY system configuration, as far as not given on page 1.

DASY Version	DASY5	V52.8.7
Extrapolation	Advanced Extrapolation	
Phantom	Modular Flat Phantom	
Distance Dipole Center - TSL	10 mm	with Spacer
Zoom Scan Resolution	dx, dy, dz = 5 mm	
Frequency	1900 MHz ± 1 MHz	

Head TSL parameters

The following parameters and calculations were applied.

	Temperature	Permittivity	Conductivity
Nominal Head TSL parameters	22.0 °C	40.0	1.40 mho/m
Measured Head TSL parameters	(22.0 ± 0.2) °C	38.9 ± 6 %	1.39 mho/m ± 6 %
Head TSL temperature change during test	< 0.5 °C	----	----

SAR result with Head TSL

SAR averaged over 1 cm³ (1 g) of Head TSL	Condition	
SAR measured	250 mW input power	10.2 W/kg
SAR for nominal Head TSL parameters	normalized to 1W	40.7 W/kg ± 17.0 % (k=2)

SAR averaged over 10 cm³ (10 g) of Head TSL	condition	
SAR measured	250 mW input power	5.31 W/kg
SAR for nominal Head TSL parameters	normalized to 1W	21.2 W/kg ± 16.5 % (k=2)

Body TSL parameters

The following parameters and calculations were applied.

	Temperature	Permittivity	Conductivity
Nominal Body TSL parameters	22.0 °C	53.3	1.52 mho/m
Measured Body TSL parameters	(22.0 ± 0.2) °C	52.8 ± 6 %	1.49 mho/m ± 6 %
Body TSL temperature change during test	< 0.5 °C	----	----

SAR result with Body TSL

SAR averaged over 1 cm³ (1 g) of Body TSL	Condition	
SAR measured	250 mW input power	9.73 W/kg
SAR for nominal Body TSL parameters	normalized to 1W	39.3 W/kg ± 17.0 % (k=2)

SAR averaged over 10 cm³ (10 g) of Body TSL	condition	
SAR measured	250 mW input power	5.15 W/kg
SAR for nominal Body TSL parameters	normalized to 1W	20.7 W/kg ± 16.5 % (k=2)

Appendix

Antenna Parameters with Head TSL

Impedance, transformed to feed point	52.5 Ω + 5.5 j Ω
Return Loss	- 24.6 dB

Antenna Parameters with Body TSL

Impedance, transformed to feed point	48.0 Ω + 6.7 j Ω
Return Loss	- 23.0 dB

General Antenna Parameters and Design

Electrical Delay (one direction)	1.197 ns
----------------------------------	----------

After long term use with 100W radiated power, only a slight warming of the dipole near the feedpoint can be measured.

The dipole is made of standard semirigid coaxial cable. The center conductor of the feeding line is directly connected to the second arm of the dipole. The antenna is therefore short-circuited for DC-signals. On some of the dipoles, small end caps are added to the dipole arms in order to improve matching when loaded according to the position as explained in the "Measurement Conditions" paragraph. The SAR data are not affected by this change. The overall dipole length is still according to the Standard.

No excessive force must be applied to the dipole arms, because they might bend or the soldered connections near the feedpoint may be damaged.

Additional EUT Data

Manufactured by	SPEAG
Manufactured on	March 11, 2011

DASY5 Validation Report for Head TSL

Date: 27.02.2014

Test Laboratory: SPEAG, Zurich, Switzerland

DUT: Dipole 1900 MHz; Type: D1900V2; Serial: D1900V2 - SN: 5d148

Communication System: UID 0 - CW; Frequency: 1900 MHz

Medium parameters used: $f = 1900$ MHz; $\sigma = 1.39$ S/m; $\epsilon_r = 38.9$; $\rho = 1000$ kg/m³

Phantom section: Flat Section

Measurement Standard: DASY5 (IEEE/IEC/ANSI C63.19-2007)

DASY52 Configuration:

- Probe: ES3DV3 - SN3205; ConvF(5.06, 5.06, 5.06); Calibrated: 30.12.2013;
- Sensor-Surface: 3mm (Mechanical Surface Detection)
- Electronics: DAE4 Sn601; Calibrated: 25.04.2013
- Phantom: Flat Phantom 5.0 (front); Type: QD000P50AA; Serial: 1001
- DASY52 52.8.7(1137); SEMCAD X 14.6.10(7164)

Dipole Calibration for Head Tissue/Pin=250 mW, d=10mm/Zoom Scan (7x7x7)/Cube 0:

Measurement grid: dx=5mm, dy=5mm, dz=5mm

Reference Value = 98.796 V/m; Power Drift = 0.02 dB

Peak SAR (extrapolated) = 18.9 W/kg

SAR(1 g) = 10.2 W/kg; SAR(10 g) = 5.31 W/kg

Maximum value of SAR (measured) = 12.8 W/kg

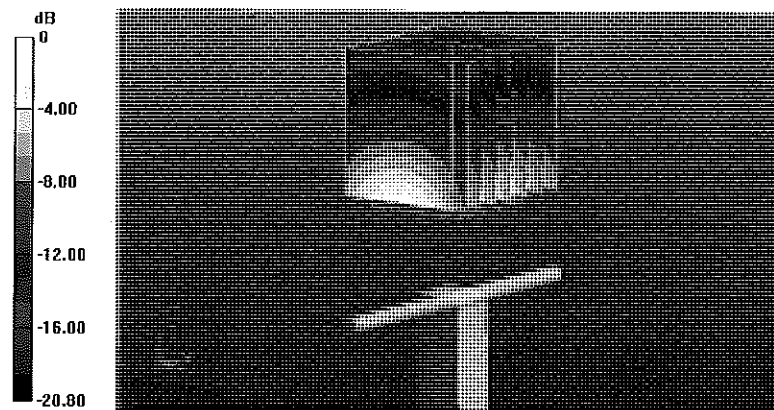

0 dB = 12.8 W/kg = 11.07 dBW/kg

Impedance Measurement Plot for Head TSL

27 Feb 2014 09:42:31

CH1 S11 1 U FS

4: 52.533 Δ 5.5234 Δ 462.67 μ H

1 900.000 000 MHz

*
De1

CA

Avg
16

H1d

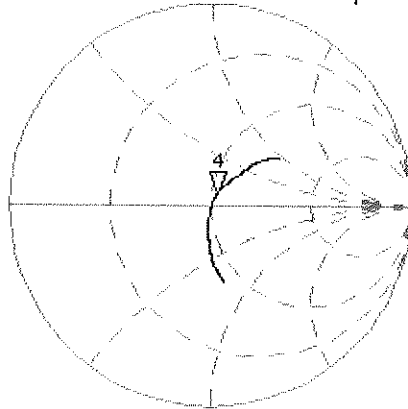

CH2 S11 LOG

5 dB/REF -20 dB

4:-24.552 dB 1 900.000 000 MHz

CA

Avg
16

H1d

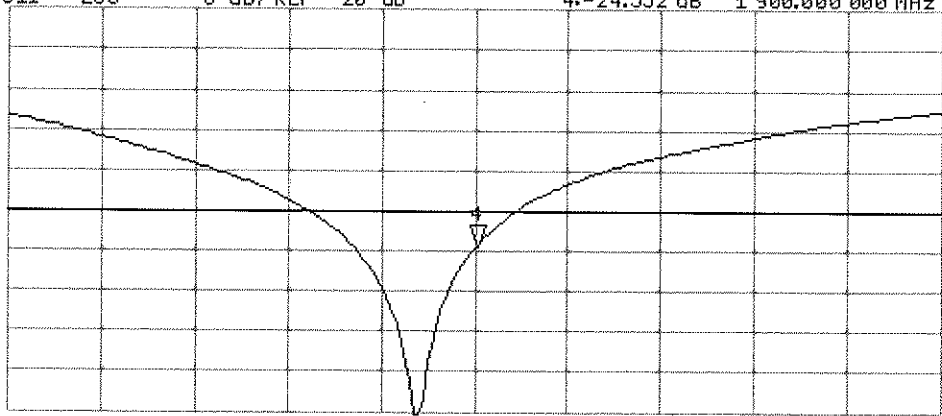

START 1 700.000 000 MHz

STOP 2 100.000 000 MHz

DASY5 Validation Report for Body TSL

Date: 27.02.2014

Test Laboratory: SPEAG, Zurich, Switzerland

DUT: Dipole 1900 MHz; Type: D1900V2; Serial: D1900V2 - SN: 5d148

Communication System: UID 0 - CW; Frequency: 1900 MHz

Medium parameters used: $f = 1900$ MHz; $\sigma = 1.49$ S/m; $\epsilon_r = 52.8$; $\rho = 1000$ kg/m³

Phantom section: Flat Section

Measurement Standard: DASY5 (IEEE/IEC/ANSI C63.19-2007)

DASY52 Configuration:

- Probe: ES3DV3 - SN3205; ConvF(4.76, 4.76, 4.76); Calibrated: 30.12.2013;
- Sensor-Surface: 3mm (Mechanical Surface Detection)
- Electronics: DAE4 Sn601; Calibrated: 25.04.2013
- Phantom: Flat Phantom 5.0 (back); Type: QD000P50AA; Serial: 1002
- DASY52 52.8.7(1137); SEMCAD X 14.6.10(7164)

Dipole Calibration for Body Tissue/Pin=250 mW, d=10mm/Zoom Scan (7x7x7)/Cube 0:

Measurement grid: dx=5mm, dy=5mm, dz=5mm

Reference Value = 94.520 V/m; Power Drift = -0.02 dB

Peak SAR (extrapolated) = 17.0 W/kg

SAR(1 g) = 9.73 W/kg; SAR(10 g) = 5.15 W/kg

Maximum value of SAR (measured) = 12.2 W/kg

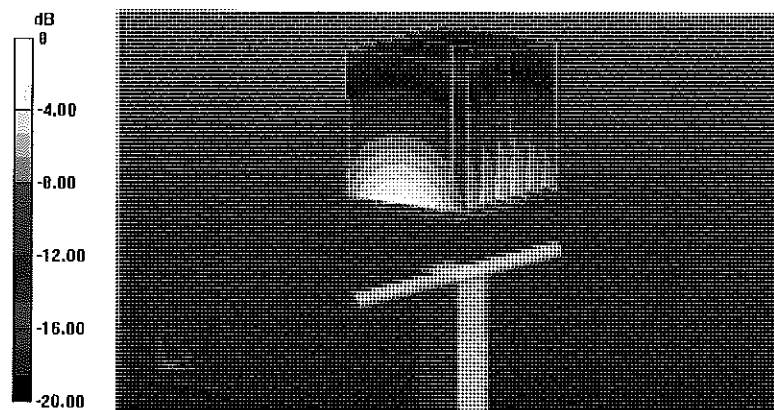

0 dB = 12.2 W/kg = 10.86 dBW/kg

Impedance Measurement Plot for Body TSL

27 Feb 2014 09:42:04

CH1 S11 1 U FS

4: 47.971 Ω 6.6777 Ω 559.37 pF

1 900.000 000 MHz

#

De1

CA

Avg
16

H1d

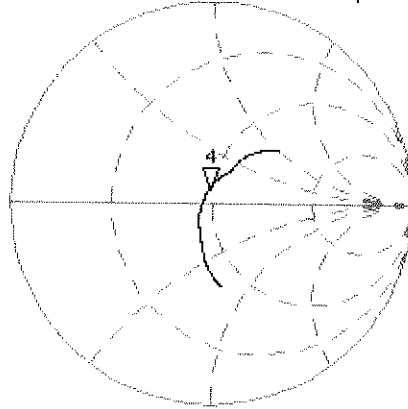

CH2 S11 LOG

5 dB/REF -20 dB

4:-22.970 dB 1 900.000 000 MHz

CA

Avg
16

H1d

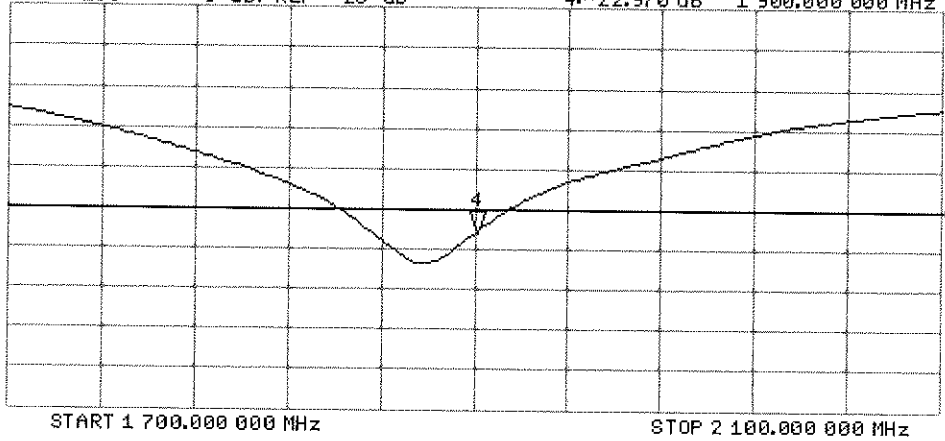

START 1 700.000 000 MHz

STOP 2 100.000 000 MHz



Accredited by the Swiss Accreditation Service (SAS)
The Swiss Accreditation Service is one of the signatories to the EA
Multilateral Agreement for the recognition of calibration certificates

Accreditation No.: **SCS 108**

Client **PC Test**

Certificate No: **D2450V2-797_Jan14**

CALIBRATION CERTIFICATE

Object **D2450V2 - SN: 797**

Calibration procedure(s) **QA CAL-05.v9
Calibration procedure for dipole validation kits above 700 MHz**

Calibration date: **January 21, 2014**

*CC ✓
2/5/14*

This calibration certificate documents the traceability to national standards, which realize the physical units of measurements (SI).
The measurements and the uncertainties with confidence probability are given on the following pages and are part of the certificate.

All calibrations have been conducted in the closed laboratory facility: environment temperature (22 ± 3)°C and humidity < 70%.

Calibration Equipment used (M&TE critical for calibration)

Primary Standards	ID #	Cal Date (Certificate No.)	Scheduled Calibration
Power meter EPM-442A	GB37480704	09-Oct-13 (No. 217-01827)	Oct-14
Power sensor HP 8481A	US37292783	09-Oct-13 (No. 217-01827)	Oct-14
Power sensor HP 8481A	MY41092317	09-Oct-13 (No. 217-01828)	Oct-14
Reference 20 dB Attenuator	SN: 5058 (20k)	04-Apr-13 (No. 217-01736)	Apr-14
Type-N mismatch combination	SN: 5047.3 / 06327	04-Apr-13 (No. 217-01739)	Apr-14
Reference Probe ES3DV3	SN: 3205	30-Dec-13 (No. ES3-3205_Dec13)	Dec-14
DAE4	SN: 601	25-Apr-13 (No. DAE4-601_Apr13)	Apr-14
Secondary Standards	ID #	Check Date (in house)	Scheduled Check
RF generator R&S SMT-06	100005	04-Aug-99 (in house check Oct-13)	In house check: Oct-16
Network Analyzer HP 8753E	US37390585 S4206	18-Oct-01 (in house check Oct-13)	In house check: Oct-14

Calibrated by:	Name Israe El-Naouq	Function Laboratory Technician	Signature
Approved by:	Katja Pokovic	Technical Manager	

Issued: January 21, 2014

This calibration certificate shall not be reproduced except in full without written approval of the laboratory.



Accredited by the Swiss Accreditation Service (SAS)

Accreditation No.: **SCS 108**

The Swiss Accreditation Service is one of the signatories to the EA
Multilateral Agreement for the recognition of calibration certificates

Glossary:

TSL	tissue simulating liquid
ConvF	sensitivity in TSL / NORM x,y,z
N/A	not applicable or not measured

Calibration is Performed According to the Following Standards:

- IEEE Std 1528-2013, "IEEE Recommended Practice for Determining the Peak Spatial-Averaged Specific Absorption Rate (SAR) in the Human Head from Wireless Communications Devices: Measurement Techniques", June 2013
- IEC 62209-1, "Procedure to measure the Specific Absorption Rate (SAR) for hand-held devices used in close proximity to the ear (frequency range of 300 MHz to 3 GHz)", February 2005
- KDB 865664, "SAR Measurement Requirements for 100 MHz to 6 GHz"

Additional Documentation:

- DASY4/5 System Handbook

Methods Applied and Interpretation of Parameters:

- Measurement Conditions:** Further details are available from the Validation Report at the end of the certificate. All figures stated in the certificate are valid at the frequency indicated.
- Antenna Parameters with TSL:** The dipole is mounted with the spacer to position its feed point exactly below the center marking of the flat phantom section, with the arms oriented parallel to the body axis.
- Feed Point Impedance and Return Loss:** These parameters are measured with the dipole positioned under the liquid filled phantom. The impedance stated is transformed from the measurement at the SMA connector to the feed point. The Return Loss ensures low reflected power. No uncertainty required.
- Electrical Delay:** One-way delay between the SMA connector and the antenna feed point. No uncertainty required.
- SAR measured:** SAR measured at the stated antenna input power.
- SAR normalized:** SAR as measured, normalized to an input power of 1 W at the antenna connector.
- SAR for nominal TSL parameters:** The measured TSL parameters are used to calculate the nominal SAR result.

The reported uncertainty of measurement is stated as the standard uncertainty of measurement multiplied by the coverage factor $k=2$, which for a normal distribution corresponds to a coverage probability of approximately 95%.

Measurement Conditions

DASY system configuration, as far as not given on page 1.

DASY Version	DASY5	V52.8.7
Extrapolation	Advanced Extrapolation	
Phantom	Modular Flat Phantom	
Distance Dipole Center - TSL	10 mm	with Spacer
Zoom Scan Resolution	dx, dy, dz = 5 mm	
Frequency	2450 MHz \pm 1 MHz	

Head TSL parameters

The following parameters and calculations were applied.

	Temperature	Permittivity	Conductivity
Nominal Head TSL parameters	22.0 °C	39.2	1.80 mho/m
Measured Head TSL parameters	(22.0 \pm 0.2) °C	38.7 \pm 6 %	1.86 mho/m \pm 6 %
Head TSL temperature change during test	< 0.5 °C	---	---

SAR result with Head TSL

SAR averaged over 1 cm³ (1 g) of Head TSL	Condition	
SAR measured	250 mW input power	13.2 W/kg
SAR for nominal Head TSL parameters	normalized to 1W	51.8 W/kg \pm 17.0 % (k=2)

SAR averaged over 10 cm³ (10 g) of Head TSL	condition	
SAR measured	250 mW input power	6.13 W/kg
SAR for nominal Head TSL parameters	normalized to 1W	24.3 W/kg \pm 16.5 % (k=2)

Body TSL parameters

The following parameters and calculations were applied.

	Temperature	Permittivity	Conductivity
Nominal Body TSL parameters	22.0 °C	52.7	1.95 mho/m
Measured Body TSL parameters	(22.0 \pm 0.2) °C	51.3 \pm 6 %	2.04 mho/m \pm 6 %
Body TSL temperature change during test	< 0.5 °C	---	---

SAR result with Body TSL

SAR averaged over 1 cm³ (1 g) of Body TSL	Condition	
SAR measured	250 mW input power	12.7 W/kg
SAR for nominal Body TSL parameters	normalized to 1W	49.4 W/kg \pm 17.0 % (k=2)

SAR averaged over 10 cm³ (10 g) of Body TSL	condition	
SAR measured	250 mW input power	5.86 W/kg
SAR for nominal Body TSL parameters	normalized to 1W	23.1 W/kg \pm 16.5 % (k=2)

Appendix

Antenna Parameters with Head TSL

Impedance, transformed to feed point	$53.5 \Omega + 3.2 j\Omega$
Return Loss	- 26.7 dB

Antenna Parameters with Body TSL

Impedance, transformed to feed point	$50.0 \Omega + 4.9 j\Omega$
Return Loss	- 26.2 dB

General Antenna Parameters and Design

Electrical Delay (one direction)	1.151 ns
----------------------------------	----------

After long term use with 100W radiated power, only a slight warming of the dipole near the feedpoint can be measured.

The dipole is made of standard semirigid coaxial cable. The center conductor of the feeding line is directly connected to the second arm of the dipole. The antenna is therefore short-circuited for DC-signals. On some of the dipoles, small end caps are added to the dipole arms in order to improve matching when loaded according to the position as explained in the "Measurement Conditions" paragraph. The SAR data are not affected by this change. The overall dipole length is still according to the Standard.

No excessive force must be applied to the dipole arms, because they might bend or the soldered connections near the feedpoint may be damaged.

Additional EUT Data

Manufactured by	SPEAG
Manufactured on	January 24, 2006

DASY5 Validation Report for Head TSL

Date: 21.01.2014

Test Laboratory: SPEAG, Zurich, Switzerland

DUT: Dipole 2450 MHz; Type: D2450V2; Serial: D2450V2 - SN: 797

Communication System: UID 0 - CW; Frequency: 2450 MHz

Medium parameters used: $f = 2450$ MHz; $\sigma = 1.86$ S/m; $\epsilon_r = 38.7$; $\rho = 1000$ kg/m³

Phantom section: Flat Section

Measurement Standard: DASY5 (IEEE/IEC/ANSI C63.19-2007)

DASY52 Configuration:

- Probe: ES3DV3 - SN3205; ConvF(4.53, 4.53, 4.53); Calibrated: 30.12.2013;
- Sensor-Surface: 3mm (Mechanical Surface Detection)
- Electronics: DAE4 Sn601; Calibrated: 25.04.2013
- Phantom: Flat Phantom 5.0 (front); Type: QD000P50AA; Serial: 1001
- DASY52 52.8.7(1137); SEMCAD X 14.6.10(7164)

Dipole Calibration for Head Tissue/Pin=250 mW, d=10mm/Zoom Scan (7x7x7)/Cube 0:

Measurement grid: dx=5mm, dy=5mm, dz=5mm

Reference Value = 99.151 V/m; Power Drift = 0.05 dB

Peak SAR (extrapolated) = 27.5 W/kg

SAR(1 g) = 13.2 W/kg; SAR(10 g) = 6.13 W/kg

Maximum value of SAR (measured) = 16.9 W/kg

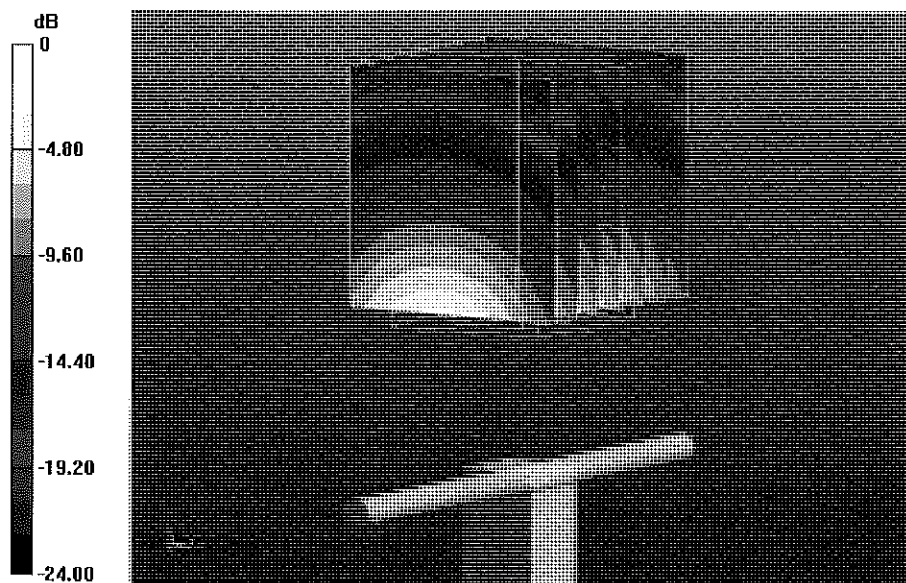

0 dB = 16.9 W/kg = 12.28 dBW/kg

Impedance Measurement Plot for Head TSL

21 Jan 2014 11:31:52

CHI S11 1 U FS 2: 53.512 Δ 3.2285 Δ 209.73 pH 2 450.000 000 MHz

*
De1
CA

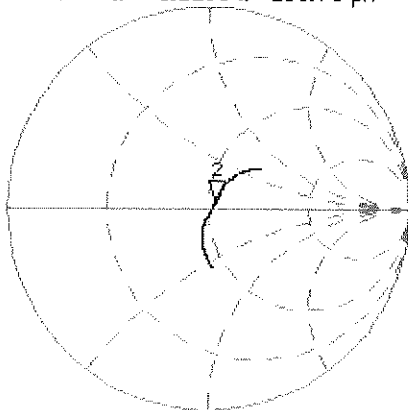

Avg
1E

H1d

CH2 S11 LOG 5 dB/REF -20 dB 2:-26.730 dB 2 450.000 000 MHz

CA

Avg
1E

H1d

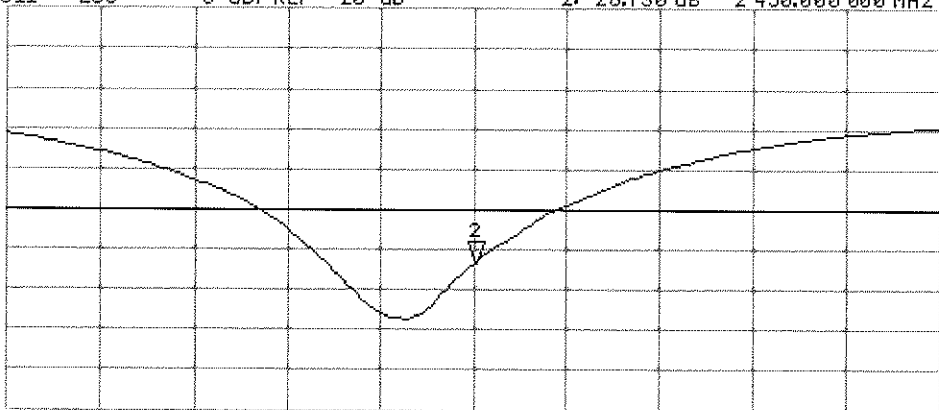

START 2 250.000 000 MHz

STOP 2 650.000 000 MHz

DASY5 Validation Report for Body TSL

Date: 21.01.2014

Test Laboratory: SPEAG, Zurich, Switzerland

DUT: Dipole 2450 MHz; Type: D2450V2; Serial: D2450V2 - SN: 797

Communication System: UID 0 - CW; Frequency: 2450 MHz

Medium parameters used: $f = 2450$ MHz; $\sigma = 2.04$ S/m; $\epsilon_r = 51.3$; $\rho = 1000$ kg/m³

Phantom section: Flat Section

Measurement Standard: DASY5 (IEEE/IEC/ANSI C63.19-2007)

DASY52 Configuration:

- Probe: ES3DV3 - SN3205; ConvF(4.35, 4.35, 4.35); Calibrated: 30.12.2013;
- Sensor-Surface: 3mm (Mechanical Surface Detection)
- Electronics: DAE4 Sn601; Calibrated: 25.04.2013
- Phantom: Flat Phantom 5.0 (back); Type: QD000P50AA; Serial: 1002
- DASY52 52.8.7(1137); SEMCAD X 14.6.10(7164)

Dipole Calibration for Body Tissue/Pin=250 mW, d=10mm/Zoom Scan (7x7x7)/Cube 0:

Measurement grid: dx=5mm, dy=5mm, dz=5mm

Reference Value = 93.709 V/m; Power Drift = 0.01 dB

Peak SAR (extrapolated) = 26.4 W/kg

SAR(1 g) = 12.7 W/kg; SAR(10 g) = 5.86 W/kg

Maximum value of SAR (measured) = 16.8 W/kg

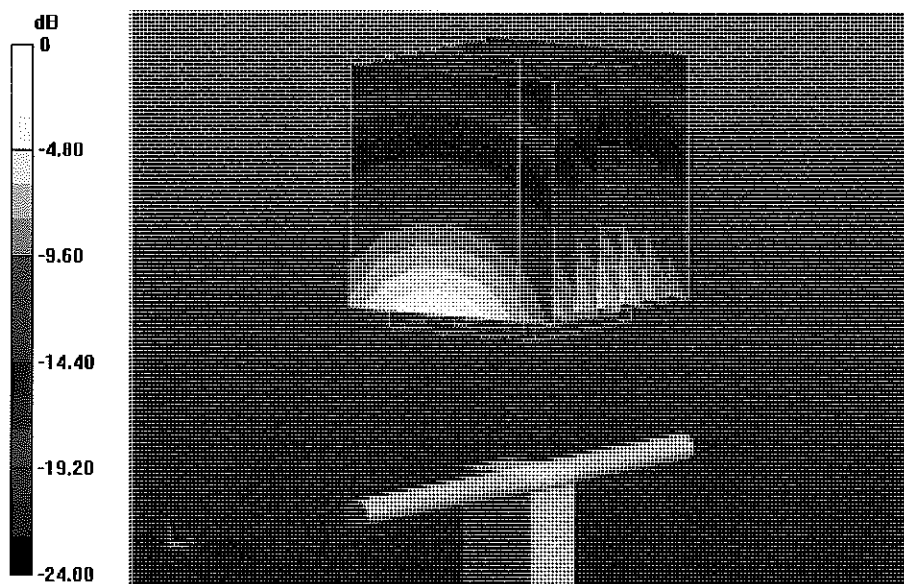

0 dB = 16.8 W/kg = 12.25 dBW/kg

Impedance Measurement Plot for Body TSL

21 Jan 2014 11:31:29

CH1 S11 1 U FS 2: 49.994 Ω 4.9258 Ω 319.98 μH 2 450.000 000 MHz

*
Del

CA

Avg
16

H1d

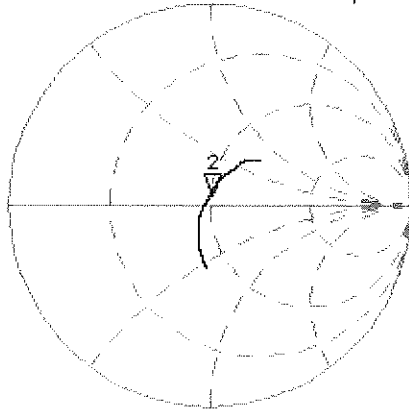

CH2 S11 LOG 5 dB/REF -20 dB 2:-26.162 dB 2 450.000 000 MHz

CA

Avg
16

H1d

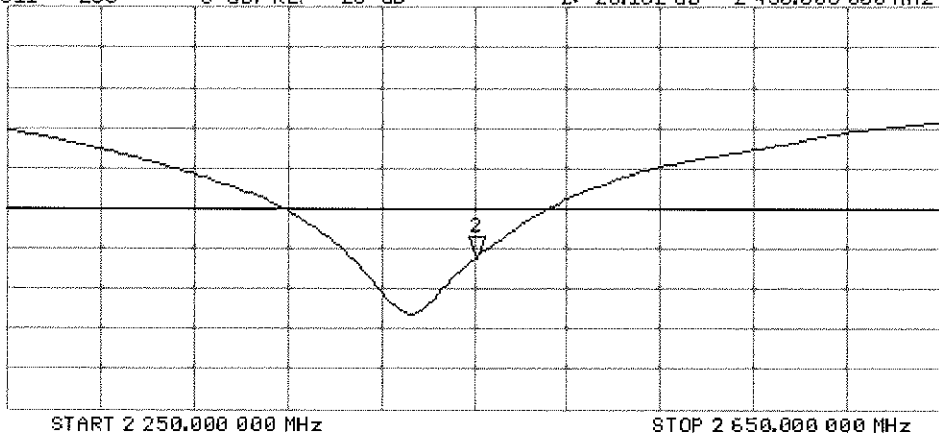

START 2 250.000 000 MHz

STOP 2 650.000 000 MHz



Accredited by the Swiss Accreditation Service (SAS)
The Swiss Accreditation Service is one of the signatories to the EA
Multilateral Agreement for the recognition of calibration certificates

Accreditation No.: **SCS 108**

Client **PC Test**

Certificate No: **D5GHzV2-1007_Sep13/2**

CALIBRATION CERTIFICATE (Replacement of No: D5GHzV2-1007_Sep13)

Object **D5GHzV2 - SN: 1007**

Calibration procedure(s) **QA CAL-22.v2
Calibration procedure for dipole validation kits between 3-6 GHz**

CCV
10/15/13

Calibration date: **September 23, 2013**

This calibration certificate documents the traceability to national standards, which realize the physical units of measurements (SI).
The measurements and the uncertainties with confidence probability are given on the following pages and are part of the certificate.

All calibrations have been conducted in the closed laboratory facility: environment temperature (22 ± 3)°C and humidity < 70%.

Calibration Equipment used (M&TE critical for calibration)

Primary Standards	ID #	Cal Date (Certificate No.)	Scheduled Calibration
Power meter EPM-442A	GB37480704	01-Nov-12 (No. 217-01640)	Oct-13
Power sensor HP 8481A	US37292783	01-Nov-12 (No. 217-01640)	Oct-13
Reference 20 dB Attenuator	SN: 5058 (20k)	04-Apr-13 (No. 217-01736)	Apr-14
Type-N mismatch combination	SN: 5047.3 / 06327	04-Apr-13 (No. 217-01739)	Apr-14
Reference Probe EX3DV4	SN: 3503	28-Dec-12 (No. EX3-3503_Dec12)	Dec-13
DAE4	SN: 601	25-Apr-13 (No. DAE4-601_Apr13)	Apr-14
Secondary Standards	ID #	Check Date (in house)	Scheduled Check
Power sensor HP 8481A	MY41092317	18-Oct-02 (in house check Oct-11)	In house check: Oct-13
RF generator R&S SMT-06	100005	04-Aug-99 (in house check Oct-11)	In house check: Oct-13
Network Analyzer HP 8753E	US37390585 S4206	18-Oct-01 (in house check Oct-12)	In house check: Oct-13

Calibrated by:	Name Leif Klysner	Function Laboratory Technician	Signature
Approved by:	Name Katja Pokovic	Function Technical Manager	Signature

Issued: October 4, 2013

This calibration certificate shall not be reproduced except in full without written approval of the laboratory.



Accredited by the Swiss Accreditation Service (SAS)
The Swiss Accreditation Service is one of the signatories to the EA
Multilateral Agreement for the recognition of calibration certificates

Accreditation No.: **SCS 108**

Glossary:

TSL	tissue simulating liquid
ConvF	sensitivity in TSL / NORM x,y,z
N/A	not applicable or not measured

Calibration is Performed According to the Following Standards:

- IEC 62209-2, "Evaluation of Human Exposure to Radio Frequency Fields from Handheld and Body-Mounted Wireless Communication Devices in the Frequency Range of 30 MHz to 6 GHz: Human models, Instrumentation, and Procedures"; Part 2: "Procedure to determine the Specific Absorption Rate (SAR) for including accessories and multiple transmitters", March 2010
- KDB 865664, "SAR Measurement Requirements for 100 MHz to 6 GHz"
- IEEE Std 1528-2013, "IEEE Recommended Practice for Determining the Peak Spatial-Averaged Specific Absorption Rate (SAR) in the Human Head from Wireless Communications Devices: Measurement Techniques", June 2013

Additional Documentation:

- DASY4/5 System Handbook

Methods Applied and Interpretation of Parameters:

- Measurement Conditions:** Further details are available from the Validation Report at the end of the certificate. All figures stated in the certificate are valid at the frequency indicated.
- Antenna Parameters with TSL:** The dipole is mounted with the spacer to position its feed point exactly below the center marking of the flat phantom section, with the arms oriented parallel to the body axis.
- Feed Point Impedance and Return Loss:** These parameters are measured with the dipole positioned under the liquid filled phantom. The impedance stated is transformed from the measurement at the SMA connector to the feed point. The Return Loss ensures low reflected power. No uncertainty required.
- Electrical Delay:** One-way delay between the SMA connector and the antenna feed point. No uncertainty required.
- SAR measured:** SAR measured at the stated antenna input power.
- SAR normalized:** SAR as measured, normalized to an input power of 1 W at the antenna connector.
- SAR for nominal TSL parameters:** The measured TSL parameters are used to calculate the nominal SAR result.

The reported uncertainty of measurement is stated as the standard uncertainty of measurement multiplied by the coverage factor $k=2$, which for a normal distribution corresponds to a coverage probability of approximately 95%.

Measurement Conditions

DASY system configuration, as far as not given on page 1.

DASY Version	DASY5	V52.8.7
Extrapolation	Advanced Extrapolation	
Phantom	Modular Flat Phantom V5.0	
Distance Dipole Center - TSL	10 mm	with Spacer
Zoom Scan Resolution	dx, dy = 4.0 mm, dz = 1.4 mm	Graded Ratio = 1.4 (Z direction)
Frequency	5200 MHz ± 1 MHz 5300 MHz ± 1 MHz 5500 MHz ± 1 MHz 5600 MHz ± 1 MHz 5800 MHz ± 1 MHz	

Head TSL parameters at 5200 MHz

The following parameters and calculations were applied.

	Temperature	Permittivity	Conductivity
Nominal Head TSL parameters	22.0 °C	36.0	4.66 mho/m
Measured Head TSL parameters	(22.0 ± 0.2) °C	35.8 ± 6 %	4.48 mho/m ± 6 %
Head TSL temperature change during test	< 0.5 °C	----	----

SAR result with Head TSL at 5200 MHz

SAR averaged over 1 cm³ (1 g) of Head TSL	Condition	
SAR measured	100 mW input power	7.77 W/kg
SAR for nominal Head TSL parameters	normalized to 1W	77.5 W/kg ± 19.9 % (k=2)

SAR averaged over 10 cm³ (10 g) of Head TSL	condition	
SAR measured	100 mW input power	2.23 W/kg
SAR for nominal Head TSL parameters	normalized to 1W	22.2 W/kg ± 19.5 % (k=2)

Head TSL parameters at 5300 MHz

The following parameters and calculations were applied.

	Temperature	Permittivity	Conductivity
Nominal Head TSL parameters	22.0 °C	35.9	4.76 mho/m
Measured Head TSL parameters	(22.0 ± 0.2) °C	35.6 ± 6 %	4.62 mho/m ± 6 %
Head TSL temperature change during test	< 0.5 °C	----	----

SAR result with Head TSL at 5300 MHz

SAR averaged over 1 cm ³ (1 g) of Head TSL	Condition	
SAR measured	100 mW input power	8.04 W/kg
SAR for nominal Head TSL parameters	normalized to 1W	80.2 W / kg ± 19.9 % (k=2)

SAR averaged over 10 cm ³ (10 g) of Head TSL	condition	
SAR measured	100 mW input power	2.30 W/kg
SAR for nominal Head TSL parameters	normalized to 1W	22.9 W/kg ± 19.5 % (k=2)

Head TSL parameters at 5500 MHz

The following parameters and calculations were applied.

	Temperature	Permittivity	Conductivity
Nominal Head TSL parameters	22.0 °C	35.6	4.96 mho/m
Measured Head TSL parameters	(22.0 ± 0.2) °C	35.4 ± 6 %	4.76 mho/m ± 6 %
Head TSL temperature change during test	< 0.5 °C	----	----

SAR result with Head TSL at 5500 MHz

SAR averaged over 1 cm ³ (1 g) of Head TSL	Condition	
SAR measured	100 mW input power	8.17 W/kg
SAR for nominal Head TSL parameters	normalized to 1W	81.4 W/kg ± 19.9 % (k=2)

SAR averaged over 10 cm ³ (10 g) of Head TSL	condition	
SAR measured	100 mW input power	2.32 W/kg
SAR for nominal Head TSL parameters	normalized to 1W	23.1 W/kg ± 19.5 % (k=2)

Head TSL parameters at 5600 MHz

The following parameters and calculations were applied.

	Temperature	Permittivity	Conductivity
Nominal Head TSL parameters	22.0 °C	35.5	5.07 mho/m
Measured Head TSL parameters	(22.0 ± 0.2) °C	35.2 ± 6 %	4.86 mho/m ± 6 %
Head TSL temperature change during test	< 0.5 °C	----	----

SAR result with Head TSL at 5600 MHz

SAR averaged over 1 cm ³ (1 g) of Head TSL	Condition	
SAR measured	100 mW input power	8.03 W/kg
SAR for nominal Head TSL parameters	normalized to 1W	80.0 W/kg ± 19.9 % (k=2)

SAR averaged over 10 cm ³ (10 g) of Head TSL	condition	
SAR measured	100 mW input power	2.28 W/kg
SAR for nominal Head TSL parameters	normalized to 1W	22.7 W/kg ± 19.5 % (k=2)

Head TSL parameters at 5800 MHz

The following parameters and calculations were applied.

	Temperature	Permittivity	Conductivity
Nominal Head TSL parameters	22.0 °C	35.3	5.27 mho/m
Measured Head TSL parameters	(22.0 ± 0.2) °C	35.0 ± 6 %	5.07 mho/m ± 6 %
Head TSL temperature change during test	< 0.5 °C	----	----

SAR result with Head TSL at 5800 MHz

SAR averaged over 1 cm ³ (1 g) of Head TSL	Condition	
SAR measured	100 mW input power	7.78 W/kg
SAR for nominal Head TSL parameters	normalized to 1W	77.5 W/kg ± 19.9 % (k=2)

SAR averaged over 10 cm ³ (10 g) of Head TSL	condition	
SAR measured	100 mW input power	2.20 W/kg
SAR for nominal Head TSL parameters	normalized to 1W	21.9 W/kg ± 19.5 % (k=2)

Body TSL parameters at 5200 MHz

The following parameters and calculations were applied.

	Temperature	Permittivity	Conductivity
Nominal Body TSL parameters	22.0 °C	49.0	5.30 mho/m
Measured Body TSL parameters	(22.0 ± 0.2) °C	48.3 ± 6 %	5.36 mho/m ± 6 %
Body TSL temperature change during test	< 0.5 °C	----	----

SAR result with Body TSL at 5200 MHz

SAR averaged over 1 cm ³ (1 g) of Body TSL	Condition	
SAR measured	100 mW input power	7.28 W/kg
SAR for nominal Body TSL parameters	normalized to 1W	72.6 W/kg ± 19.9 % (k=2)

SAR averaged over 10 cm ³ (10 g) of Body TSL	condition	
SAR measured	100 mW input power	2.03 W/kg
SAR for nominal Body TSL parameters	normalized to 1W	20.2 W/kg ± 19.5 % (k=2)

Body TSL parameters at 5300 MHz

The following parameters and calculations were applied.

	Temperature	Permittivity	Conductivity
Nominal Body TSL parameters	22.0 °C	48.9	5.42 mho/m
Measured Body TSL parameters	(22.0 ± 0.2) °C	48.1 ± 6 %	5.56 mho/m ± 6 %
Body TSL temperature change during test	< 0.5 °C	----	----

SAR result with Body TSL at 5300 MHz

SAR averaged over 1 cm ³ (1 g) of Body TSL	Condition	
SAR measured	100 mW input power	7.49 W/kg
SAR for nominal Body TSL parameters	normalized to 1W	74.7 W/kg ± 19.9 % (k=2)

SAR averaged over 10 cm ³ (10 g) of Body TSL	condition	
SAR measured	100 mW input power	2.09 W/kg
SAR for nominal Body TSL parameters	normalized to 1W	20.8 W/kg ± 19.5 % (k=2)

Body TSL parameters at 5500 MHz

The following parameters and calculations were applied.

	Temperature	Permittivity	Conductivity
Nominal Body TSL parameters	22.0 °C	48.6	5.65 mho/m
Measured Body TSL parameters	(22.0 ± 0.2) °C	47.8 ± 6 %	5.75 mho/m ± 6 %
Body TSL temperature change during test	< 0.5 °C	----	----

SAR result with Body TSL at 5500 MHz

SAR averaged over 1 cm ³ (1 g) of Body TSL	Condition	
SAR measured	100 mW input power	7.61 W/kg
SAR for nominal Body TSL parameters	normalized to 1W	75.9 W/kg ± 19.9 % (k=2)

SAR averaged over 10 cm ³ (10 g) of Body TSL	condition	
SAR measured	100 mW input power	2.11 W/kg
SAR for nominal Body TSL parameters	normalized to 1W	21.0 W/kg ± 19.5 % (k=2)

Body TSL parameters at 5600 MHz

The following parameters and calculations were applied.

	Temperature	Permittivity	Conductivity
Nominal Body TSL parameters	22.0 °C	48.5	5.77 mho/m
Measured Body TSL parameters	(22.0 ± 0.2) °C	47.6 ± 6 %	5.88 mho/m ± 6 %
Body TSL temperature change during test	< 0.5 °C	----	----

SAR result with Body TSL at 5600 MHz

SAR averaged over 1 cm ³ (1 g) of Body TSL	Condition	
SAR measured	100 mW input power	7.75 W/kg
SAR for nominal Body TSL parameters	normalized to 1W	77.3 W/kg ± 19.9 % (k=2)

SAR averaged over 10 cm ³ (10 g) of Body TSL	condition	
SAR measured	100 mW input power	2.16 W/kg
SAR for nominal Body TSL parameters	normalized to 1W	21.5 W/kg ± 19.5 % (k=2)

Body TSL parameters at 5800 MHz

The following parameters and calculations were applied.

	Temperature	Permittivity	Conductivity
Nominal Body TSL parameters	22.0 °C	48.2	6.00 mho/m
Measured Body TSL parameters	(22.0 ± 0.2) °C	47.3 ± 6 %	6.17 mho/m ± 6 %
Body TSL temperature change during test	< 0.5 °C	----	----

SAR result with Body TSL at 5800 MHz

SAR averaged over 1 cm ³ (1 g) of Body TSL	Condition	
SAR measured	100 mW input power	7.31 W/kg
SAR for nominal Body TSL parameters	normalized to 1W	72.9 W/kg ± 19.9 % (k=2)

SAR averaged over 10 cm ³ (10 g) of Body TSL	condition	
SAR measured	100 mW input power	2.02 W/kg
SAR for nominal Body TSL parameters	normalized to 1W	20.1 W/kg ± 19.5 % (k=2)

Appendix

Antenna Parameters with Head TSL at 5200 MHz

Impedance, transformed to feed point	52.4 Ω - 11.0 j Ω
Return Loss	- 19.2 dB

Antenna Parameters with Head TSL at 5300 MHz

Impedance, transformed to feed point	56.8 Ω - 4.4 j Ω
Return Loss	- 22.3 dB

Antenna Parameters with Head TSL at 5500 MHz

Impedance, transformed to feed point	48.8 Ω - 5.4 j Ω
Return Loss	- 25.1 dB

Antenna Parameters with Head TSL at 5600 MHz

Impedance, transformed to feed point	57.3 Ω - 8.7 j Ω
Return Loss	- 19.5 dB

Antenna Parameters with Head TSL at 5800 MHz

Impedance, transformed to feed point	56.9 Ω + 1.6 j Ω
Return Loss	- 23.5 dB

Antenna Parameters with Body TSL at 5200 MHz

Impedance, transformed to feed point	53.1 Ω - 10.3 j Ω
Return Loss	- 19.7 dB

Antenna Parameters with Body TSL at 5300 MHz

Impedance, transformed to feed point	54.3 Ω - 1.5 j Ω
Return Loss	- 27.2 dB

Antenna Parameters with Body TSL at 5500 MHz

Impedance, transformed to feed point	49.7 Ω - 3.6 j Ω
Return Loss	- 28.7 dB

Antenna Parameters with Body TSL at 5600 MHz

Impedance, transformed to feed point	58.2 Ω - 5.2 j Ω
Return Loss	- 20.9 dB

Antenna Parameters with Body TSL at 5800 MHz

Impedance, transformed to feed point	58.7 Ω + 3.9 j Ω
Return Loss	- 21.1 dB

General Antenna Parameters and Design

Electrical Delay (one direction)	1.201 ns
----------------------------------	----------

After long term use with 100W radiated power, only a slight warming of the dipole near the feedpoint can be measured.

The dipole is made of standard semirigid coaxial cable. The center conductor of the feeding line is directly connected to the second arm of the dipole. The antenna is therefore short-circuited for DC-signals. On some of the dipoles, small end caps are added to the dipole arms in order to improve matching when loaded according to the position as explained in the "Measurement Conditions" paragraph. The SAR data are not affected by this change. The overall dipole length is still according to the Standard.

No excessive force must be applied to the dipole arms, because they might bend or the soldered connections near the feedpoint may be damaged.

Additional EUT Data

Manufactured by	SPEAG
Manufactured on	August 28, 2003

DASY5 Validation Report for Head TSL

Date: 23.09.2013

Test Laboratory: SPEAG, Zurich, Switzerland

DUT: Dipole 5GHz; Type: D5GHzV2; Serial: D5GHzV2 - SN: 1007

Communication System: UID 0 - CW ; Frequency: 5200 MHz, Frequency: 5300 MHz, Frequency: 5500 MHz, Frequency: 5600 MHz, Frequency: 5800 MHz

Medium parameters used: $f = 5200$ MHz; $\sigma = 4.48$ S/m; $\epsilon_r = 35.8$; $\rho = 1000$ kg/m³, Medium parameters used: $f = 5300$ MHz; $\sigma = 4.62$ S/m; $\epsilon_r = 35.6$; $\rho = 1000$ kg/m³, Medium parameters used: $f = 5500$ MHz; $\sigma = 4.76$ S/m; $\epsilon_r = 35.4$; $\rho = 1000$ kg/m³, Medium parameters used: $f = 5600$ MHz; $\sigma = 4.86$ S/m; $\epsilon_r = 35.2$; $\rho = 1000$ kg/m³, Medium parameters used: $f = 5800$ MHz; $\sigma = 5.07$ S/m; $\epsilon_r = 35$; $\rho = 1000$ kg/m³

Phantom section: Flat Section

Measurement Standard: DASY5 (IEEE/IEC/ANSI C63.19-2007)

DASY52 Configuration:

- Probe: EX3DV4 - SN3503; ConvF(5.41, 5.41, 5.41); Calibrated: 28.12.2012, ConvF(5.1, 5.1, 5.1); Calibrated: 28.12.2012, ConvF(4.91, 4.91, 4.91); Calibrated: 28.12.2012, ConvF(4.76, 4.76, 4.76); Calibrated: 28.12.2012, ConvF(4.81, 4.81, 4.81); Calibrated: 28.12.2012;
- Sensor-Surface: 1.4mm (Mechanical Surface Detection)
- Electronics: DAE4 Sn601; Calibrated: 25.04.2013
- Phantom: Flat Phantom 5.0 (front); Type: QD000P50AA; Serial: 1001
- DASY52 52.8.7(1137); SEMCAD X 14.6.10(7164)

Dipole Calibration for Head Tissue/Pin=100mW, dist=10mm, f=5200 MHz/Zoom Scan, dist=1.4mm (8x8x7)/Cube 0: Measurement grid: dx=4mm, dy=4mm, dz=1.4mm

Reference Value = 63.505 V/m; Power Drift = 0.07 dB

Peak SAR (extrapolated) = 28.1 W/kg

SAR(1 g) = 7.77 W/kg; SAR(10 g) = 2.23 W/kg

Maximum value of SAR (measured) = 18.1 W/kg

Dipole Calibration for Head Tissue/Pin=100mW, dist=10mm, f=5300 MHz/Zoom Scan, dist=1.4mm (8x8x7)/Cube 0: Measurement grid: dx=4mm, dy=4mm, dz=1.4mm

Reference Value = 63.817 V/m; Power Drift = 0.07 dB

Peak SAR (extrapolated) = 29.7 W/kg

SAR(1 g) = 8.04 W/kg; SAR(10 g) = 2.3 W/kg

Maximum value of SAR (measured) = 18.7 W/kg

Dipole Calibration for Head Tissue/Pin=100mW, dist=10mm, f=5500 MHz/Zoom Scan, dist=1.4mm (8x8x7)/Cube 0: Measurement grid: dx=4mm, dy=4mm, dz=1.4mm

Reference Value = 64.029 V/m; Power Drift = 0.07 dB

Peak SAR (extrapolated) = 32.0 W/kg

SAR(1 g) = 8.17 W/kg; SAR(10 g) = 2.32 W/kg

Maximum value of SAR (measured) = 19.7 W/kg

Dipole Calibration for Head Tissue/Pin=100mW, dist=10mm, f=5600 MHz/Zoom Scan,

dist=1.4mm (8x8x7)/Cube 0: Measurement grid: dx=4mm, dy=4mm, dz=1.4mm

Reference Value = 63.403 V/m; Power Drift = 0.05 dB

Peak SAR (extrapolated) = 31.3 W/kg

SAR(1 g) = 8.03 W/kg; SAR(10 g) = 2.28 W/kg

Maximum value of SAR (measured) = 19.3 W/kg

Dipole Calibration for Head Tissue/Pin=100mW, dist=10mm, f=5800 MHz/Zoom Scan,

dist=1.4mm (8x8x7)/Cube 0: Measurement grid: dx=4mm, dy=4mm, dz=1.4mm

Reference Value = 60.987 V/m; Power Drift = 0.06 dB

Peak SAR (extrapolated) = 31.9 W/kg

SAR(1 g) = 7.78 W/kg; SAR(10 g) = 2.2 W/kg

Maximum value of SAR (measured) = 19.0 W/kg

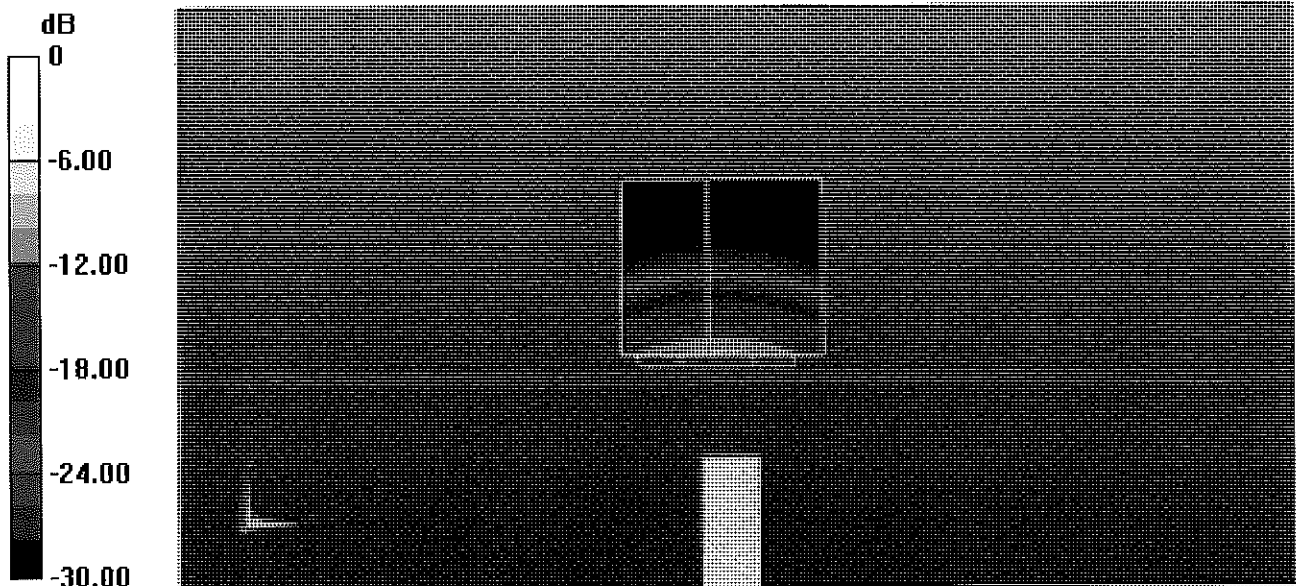

0 dB = 19.0 W/kg = 12.79 dBW/kg

Impedance Measurement Plot for Head TSL

23 Sep 2013 11:11:14

CH1 S11 1 U FS 1: 52.408 Ω -10.990 Ω 2.7849 pF 5 200.000 000 MHz

*
Del
Cor
Avg
16
H1d

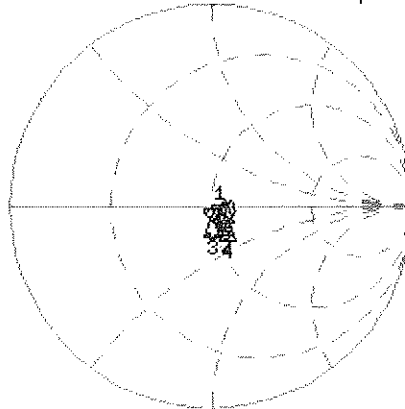

CH1 Markers

2: 56.846 Ω
-4.4492 Ω
5.30000 GHz
3: 48.834 Ω
-5.3730 Ω
5.50000 GHz
4: 57.303 Ω
-8.6738 Ω
5.60000 GHz
5: 56.939 Ω
1.5527 Ω
5.80000 GHz

CH2 S11 L00 5 dB/REF -20 dB 1:-19.232 dB 5 200.000 000 MHz

Cor
Avg
16
H1d

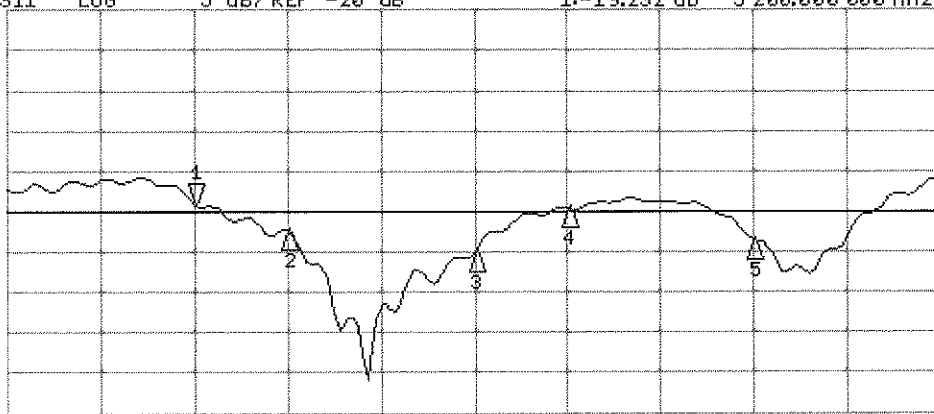

CH2 Markers

2:-22.341 dB
5.30000 GHz
3:-25.105 dB
5.50000 GHz
4:-19.547 dB
5.60000 GHz
5:-23.545 dB
5.80000 GHz

START 5 000.000 000 MHz

STOP 6 000.000 000 MHz

DASY5 Validation Report for Body TSL

Date: 20.09.2013

Test Laboratory: SPEAG, Zurich, Switzerland

DUT: Dipole 5GHz; Type: D5GHzV2; Serial: D5GHzV2 - SN: 1007

Communication System: UID 0 - CW ; Frequency: 5200 MHz, Frequency: 5300 MHz, Frequency: 5500 MHz, Frequency: 5600 MHz, Frequency: 5800 MHz

Medium parameters used: $f = 5200$ MHz; $\sigma = 5.36$ S/m; $\epsilon_r = 48.3$; $\rho = 1000$ kg/m³, Medium parameters used: $f = 5300$ MHz; $\sigma = 5.56$ S/m; $\epsilon_r = 48.1$; $\rho = 1000$ kg/m³, Medium parameters used: $f = 5500$ MHz; $\sigma = 5.75$ S/m; $\epsilon_r = 47.8$; $\rho = 1000$ kg/m³, Medium parameters used: $f = 5600$ MHz; $\sigma = 5.88$ S/m; $\epsilon_r = 47.6$; $\rho = 1000$ kg/m³, Medium parameters used: $f = 5800$ MHz; $\sigma = 6.17$ S/m; $\epsilon_r = 47.3$; $\rho = 1000$ kg/m³

Phantom section: Flat Section

Measurement Standard: DASY5 (IEEE/IEC/ANSI C63.19-2007)

DASY52 Configuration:

- Probe: EX3DV4 - SN3503; ConvF(4.91, 4.91, 4.91); Calibrated: 28.12.2012, ConvF(4.67, 4.67, 4.67); Calibrated: 28.12.2012, ConvF(4.43, 4.43, 4.43); Calibrated: 28.12.2012, ConvF(4.22, 4.22, 4.22); Calibrated: 28.12.2012, ConvF(4.38, 4.38, 4.38); Calibrated: 28.12.2012;
- Sensor-Surface: 1.4mm (Mechanical Surface Detection)
- Electronics: DAE4 Sn601; Calibrated: 25.04.2013
- Phantom: Flat Phantom 5.0 (back); Type: QD000P50AA; Serial: 1002
- DASY52 52.8.7(1137); SEMCAD X 14.6.10(7164)

Dipole Calibration for Body Tissue/Pin=100mW, dist=10mm, f=5200 MHz/Zoom Scan, dist=1.4mm (8x8x7)/Cube 0: Measurement grid: dx=4mm, dy=4mm, dz=1.4mm

Reference Value = 58.606 V/m; Power Drift = -0.02 dB

Peak SAR (extrapolated) = 28.6 W/kg

SAR(1 g) = 7.28 W/kg; SAR(10 g) = 2.03 W/kg

Maximum value of SAR (measured) = 17.2 W/kg

Dipole Calibration for Body Tissue/Pin=100mW, dist=10mm, f=5300 MHz/Zoom Scan, dist=1.4mm (8x8x7)/Cube 0: Measurement grid: dx=4mm, dy=4mm, dz=1.4mm

Reference Value = 58.305 V/m; Power Drift = 0.01 dB

Peak SAR (extrapolated) = 30.3 W/kg

SAR(1 g) = 7.49 W/kg; SAR(10 g) = 2.09 W/kg

Maximum value of SAR (measured) = 17.8 W/kg

Dipole Calibration for Body Tissue/Pin=100mW, dist=10mm, f=5500 MHz/Zoom Scan, dist=1.4mm (8x8x7)/Cube 0: Measurement grid: dx=4mm, dy=4mm, dz=1.4mm

Reference Value = 58.471 V/m; Power Drift = -0.00 dB

Peak SAR (extrapolated) = 32.4 W/kg

SAR(1 g) = 7.61 W/kg; SAR(10 g) = 2.11 W/kg

Maximum value of SAR (measured) = 18.5 W/kg

Dipole Calibration for Body Tissue/Pin=100mW, dist=10mm, f=5600 MHz/Zoom Scan, dist=1.4mm (8x8x7)/Cube 0: Measurement grid: dx=4mm, dy=4mm, dz=1.4mm

Reference Value = 58.333 V/m; Power Drift = -0.01 dB

Peak SAR (extrapolated) = 33.8 W/kg

SAR(1 g) = 7.75 W/kg; SAR(10 g) = 2.16 W/kg

Maximum value of SAR (measured) = 19.1 W/kg

Dipole Calibration for Body Tissue/Pin=100mW, dist=10mm, f=5800 MHz/Zoom Scan, dist=1.4mm (8x8x7)/Cube 0: Measurement grid: dx=4mm, dy=4mm, dz=1.4mm

Reference Value = 55.389 V/m; Power Drift = 0.00 dB

Peak SAR (extrapolated) = 34.1 W/kg

SAR(1 g) = 7.31 W/kg; SAR(10 g) = 2.02 W/kg

Maximum value of SAR (measured) = 18.3 W/kg

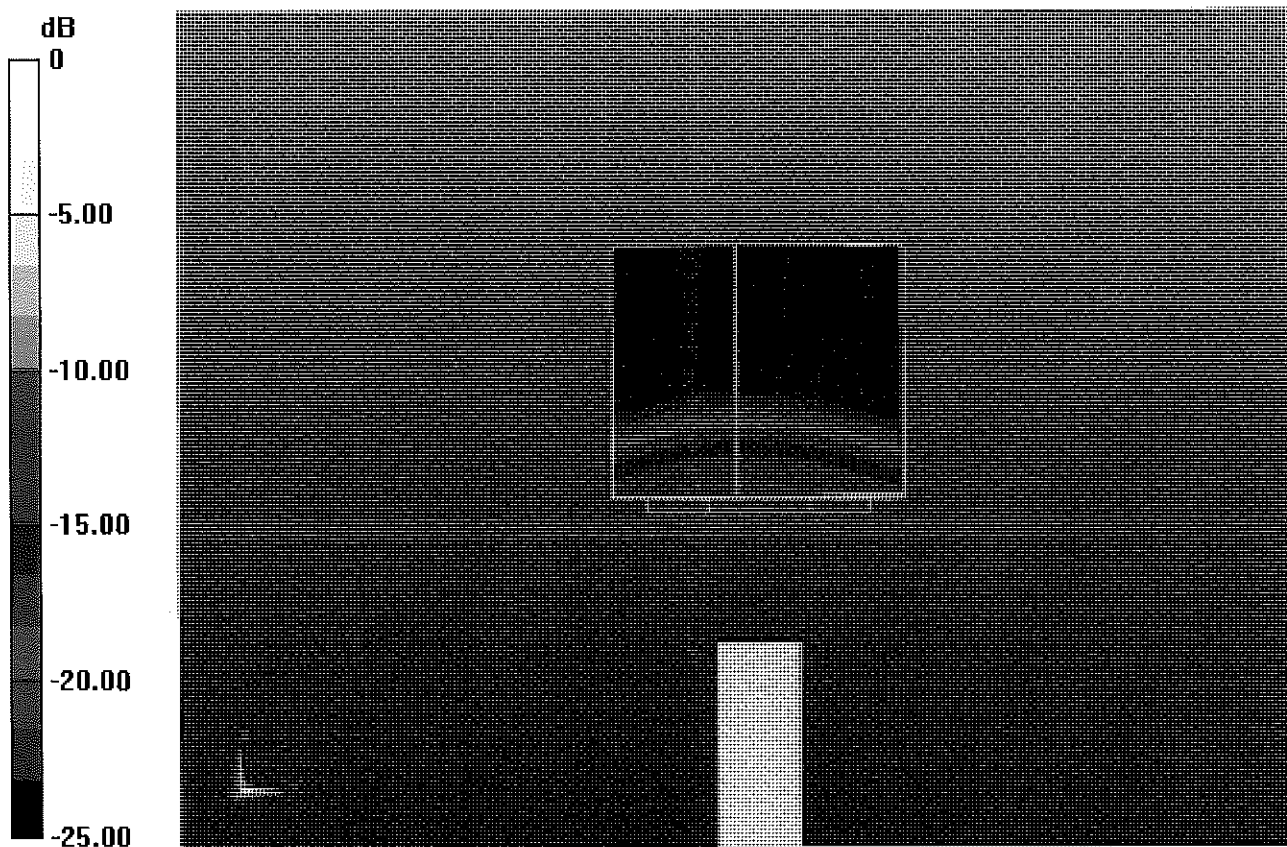

0 dB = 18.3 W/kg = 12.62 dBW/kg

Impedance Measurement Plot for Body TSL

19 Sep 2013 15:38:51

CH1 S11 1 U FS 1: 53.098 Ω -10.264 Ω 2.9820 pF 5 200.000 000 MHz

De1
Cor
Avg
0
H1d

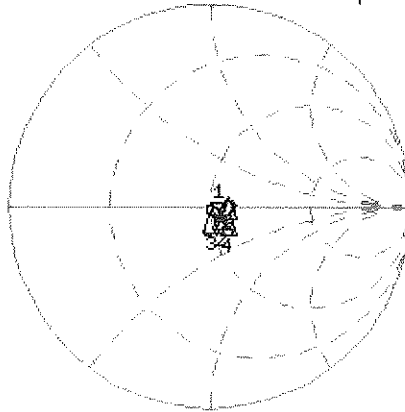

CH1 Markers

- 2: 54.285 Ω
-1.5293 Ω
5.30000 GHz
- 3: 49.717 Ω
-3.6367 Ω
5.50000 GHz
- 4: 58.225 Ω
-5.2344 Ω
5.60000 GHz
- 5: 58.725 Ω
3.9121 Ω
5.80000 GHz

CH2 S11 LOG 5 dB/REF -20 dB 1:-19.701 dB 5 200.000 000 MHz

Cor
Avg
0
H1d

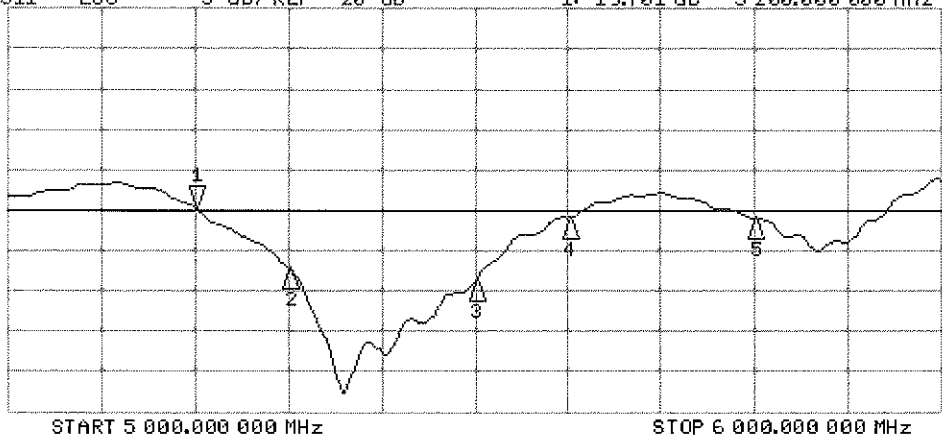

CH2 Markers

- 2: -27.201 dB
5.30000 GHz
- 3: -28.741 dB
5.50000 GHz
- 4: -20.917 dB
5.60000 GHz
- 5: -21.121 dB
5.80000 GHz



Accredited by the Swiss Accreditation Service (SAS)
The Swiss Accreditation Service is one of the signatories to the EA
Multilateral Agreement for the recognition of calibration certificates

Accreditation No.: **SCS 108**

Client **PC Test**

Certificate No: **D5GHzV2-1057_Jan14**

CALIBRATION CERTIFICATE

Object **D5GHzV2 - SN: 1057**

Calibration procedure(s) **QA CAL-22.v2
Calibration procedure for dipole validation kits between 3-6 GHz**

Calibration date: **January 27, 2014**

CC
2/5/14 ✓

This calibration certificate documents the traceability to national standards, which realize the physical units of measurements (SI).
The measurements and the uncertainties with confidence probability are given on the following pages and are part of the certificate.

All calibrations have been conducted in the closed laboratory facility: environment temperature (22 ± 3)°C and humidity < 70%.

Calibration Equipment used (M&TE critical for calibration)

Primary Standards	ID #	Cal Date (Certificate No.)	Scheduled Calibration
Power meter EPM-442A	GB37480704	09-Oct-13 (No. 217-01827)	Oct-14
Power sensor HP 8481A	US37292783	09-Oct-13 (No. 217-01827)	Oct-14
Power sensor HP 8481A	MY41092317	09-Oct-13 (No. 217-01828)	Oct-14
Reference 20 dB Attenuator	SN: 5058 (20k)	04-Apr-13 (No. 217-01736)	Apr-14
Type-N mismatch combination	SN: 5047.3 / 06327	04-Apr-13 (No. 217-01739)	Apr-14
Reference Probe EX3DV4	SN: 3503	30-Dec-13 (No. EX3-3503_Dec13)	Dec-14
DAE4	SN: 601	25-Apr-13 (No. DAE4-601_Apr13)	Apr-14
Secondary Standards	ID #	Check Date (in house)	Scheduled Check
RF generator R&S SMT-06	100005	04-Aug-99 (in house check Oct-13)	In house check: Oct-16
Network Analyzer HP 8753E	US37390585 S4206	18-Oct-01 (in house check Oct-13)	In house check: Oct-14

Calibrated by: **Israe El-Naouq** Name: **Israe El-Naouq** Function: **Laboratory Technician**

Approved by: **Kalja Pokovic** Name: **Kalja Pokovic** Technical Manager

Signature: *Israe El-Naouq*

Signature: *Kalja Pokovic*

Issued: January 27, 2014

This calibration certificate shall not be reproduced except in full without written approval of the laboratory.



Accredited by the Swiss Accreditation Service (SAS)
The Swiss Accreditation Service is one of the signatories to the EA
Multilateral Agreement for the recognition of calibration certificates

Glossary:

TSL	tissue simulating liquid
ConvF	sensitivity in TSL / NORM x,y,z
N/A	not applicable or not measured

Calibration is Performed According to the Following Standards:

- IEC 62209-2, "Evaluation of Human Exposure to Radio Frequency Fields from Handheld and Body-Mounted Wireless Communication Devices in the Frequency Range of 30 MHz to 6 GHz: Human models, Instrumentation, and Procedures"; Part 2: "Procedure to determine the Specific Absorption Rate (SAR) for including accessories and multiple transmitters", March 2010
- KDB 865664, "SAR Measurement Requirements for 100 MHz to 6 GHz"
- IEEE Std 1528-2013, "IEEE Recommended Practice for Determining the Peak Spatial-Averaged Specific Absorption Rate (SAR) in the Human Head from Wireless Communications Devices: Measurement Techniques", June 2013

Additional Documentation:

- DASY4/5 System Handbook

Methods Applied and Interpretation of Parameters:

- Measurement Conditions:** Further details are available from the Validation Report at the end of the certificate. All figures stated in the certificate are valid at the frequency indicated.
- Antenna Parameters with TSL:** The dipole is mounted with the spacer to position its feed point exactly below the center marking of the flat phantom section, with the arms oriented parallel to the body axis.
- Feed Point Impedance and Return Loss:** These parameters are measured with the dipole positioned under the liquid filled phantom. The impedance stated is transformed from the measurement at the SMA connector to the feed point. The Return Loss ensures low reflected power. No uncertainty required.
- Electrical Delay:** One-way delay between the SMA connector and the antenna feed point. No uncertainty required.
- SAR measured:** SAR measured at the stated antenna input power.
- SAR normalized:** SAR as measured, normalized to an input power of 1 W at the antenna connector.
- SAR for nominal TSL parameters:** The measured TSL parameters are used to calculate the nominal SAR result.

The reported uncertainty of measurement is stated as the standard uncertainty of measurement multiplied by the coverage factor $k=2$, which for a normal distribution corresponds to a coverage probability of approximately 95%.

Measurement Conditions

DASY system configuration, as far as not given on page 1.

DASY Version	DASY5	V52.8.7
Extrapolation	Advanced Extrapolation	
Phantom	Modular Flat Phantom V5.0	
Distance Dipole Center - TSL	10 mm	with Spacer
Zoom Scan Resolution	dx, dy = 4.0 mm, dz = 1.4 mm	Graded Ratio = 1.4 (Z direction)
Frequency	5200 MHz ± 1 MHz 5300 MHz ± 1 MHz 5500 MHz ± 1 MHz 5600 MHz ± 1 MHz 5800 MHz ± 1 MHz	

Head TSL parameters at 5200 MHz

The following parameters and calculations were applied.

	Temperature	Permittivity	Conductivity
Nominal Head TSL parameters	22.0 °C	36.0	4.66 mho/m
Measured Head TSL parameters	(22.0 ± 0.2) °C	35.0 ± 6 %	4.45 mho/m ± 6 %
Head TSL temperature change during test	< 0.5 °C	----	----

SAR result with Head TSL at 5200 MHz

SAR averaged over 1 cm³ (1 g) of Head TSL	Condition	
SAR measured	100 mW input power	7.85 W/kg
SAR for nominal Head TSL parameters	normalized to 1W	78.0 W/kg ± 19.9 % (k=2)

SAR averaged over 10 cm³ (10 g) of Head TSL	condition	
SAR measured	100 mW input power	2.25 W/kg
SAR for nominal Head TSL parameters	normalized to 1W	22.3 W/kg ± 19.5 % (k=2)

Head TSL parameters at 5300 MHz

The following parameters and calculations were applied.

	Temperature	Permittivity	Conductivity
Nominal Head TSL parameters	22.0 °C	35.9	4.76 mho/m
Measured Head TSL parameters	(22.0 ± 0.2) °C	34.9 ± 6 %	4.54 mho/m ± 6 %
Head TSL temperature change during test	< 0.5 °C	----	----

SAR result with Head TSL at 5300 MHz

SAR averaged over 1 cm ³ (1 g) of Head TSL	Condition	
SAR measured	100 mW input power	8.36 W/kg
SAR for nominal Head TSL parameters	normalized to 1W	83.0 W / kg ± 19.9 % (k=2)

SAR averaged over 10 cm ³ (10 g) of Head TSL	condition	
SAR measured	100 mW input power	2.40 W/kg
SAR for nominal Head TSL parameters	normalized to 1W	23.8 W/kg ± 19.5 % (k=2)

Head TSL parameters at 5500 MHz

The following parameters and calculations were applied.

	Temperature	Permittivity	Conductivity
Nominal Head TSL parameters	22.0 °C	35.6	4.96 mho/m
Measured Head TSL parameters	(22.0 ± 0.2) °C	34.6 ± 6 %	4.74 mho/m ± 6 %
Head TSL temperature change during test	< 0.5 °C	----	----

SAR result with Head TSL at 5500 MHz

SAR averaged over 1 cm ³ (1 g) of Head TSL	Condition	
SAR measured	100 mW input power	8.50 W/kg
SAR for nominal Head TSL parameters	normalized to 1W	84.3 W/kg ± 19.9 % (k=2)

SAR averaged over 10 cm ³ (10 g) of Head TSL	condition	
SAR measured	100 mW input power	2.42 W/kg
SAR for nominal Head TSL parameters	normalized to 1W	24.0 W/kg ± 19.5 % (k=2)

Head TSL parameters at 5600 MHz

The following parameters and calculations were applied.

	Temperature	Permittivity	Conductivity
Nominal Head TSL parameters	22.0 °C	35.5	5.07 mho/m
Measured Head TSL parameters	(22.0 ± 0.2) °C	34.5 ± 6 %	4.86 mho/m ± 6 %
Head TSL temperature change during test	< 0.5 °C	----	----

SAR result with Head TSL at 5600 MHz

SAR averaged over 1 cm ³ (1 g) of Head TSL	Condition	
SAR measured	100 mW input power	8.42 W/kg
SAR for nominal Head TSL parameters	normalized to 1W	83.5 W/kg ± 19.9 % (k=2)

SAR averaged over 10 cm ³ (10 g) of Head TSL	condition	
SAR measured	100 mW input power	2.40 W/kg
SAR for nominal Head TSL parameters	normalized to 1W	23.8 W/kg ± 19.5 % (k=2)

Head TSL parameters at 5800 MHz

The following parameters and calculations were applied.

	Temperature	Permittivity	Conductivity
Nominal Head TSL parameters	22.0 °C	35.3	5.27 mho/m
Measured Head TSL parameters	(22.0 ± 0.2) °C	34.2 ± 6 %	5.07 mho/m ± 6 %
Head TSL temperature change during test	< 0.5 °C	----	----

SAR result with Head TSL at 5800 MHz

SAR averaged over 1 cm ³ (1 g) of Head TSL	Condition	
SAR measured	100 mW input power	8.00 W/kg
SAR for nominal Head TSL parameters	normalized to 1W	79.3 W/kg ± 19.9 % (k=2)

SAR averaged over 10 cm ³ (10 g) of Head TSL	condition	
SAR measured	100 mW input power	2.28 W/kg
SAR for nominal Head TSL parameters	normalized to 1W	22.6 W/kg ± 19.5 % (k=2)

Body TSL parameters at 5200 MHz

The following parameters and calculations were applied.

	Temperature	Permittivity	Conductivity
Nominal Body TSL parameters	22.0 °C	49.0	5.30 mho/m
Measured Body TSL parameters	(22.0 ± 0.2) °C	47.3 ± 6 %	5.44 mho/m ± 6 %
Body TSL temperature change during test	< 0.5 °C	----	----

SAR result with Body TSL at 5200 MHz

SAR averaged over 1 cm ³ (1 g) of Body TSL	Condition	
SAR measured	100 mW input power	7.58 W/kg
SAR for nominal Body TSL parameters	normalized to 1W	75.3 W/kg ± 19.9 % (k=2)

SAR averaged over 10 cm ³ (10 g) of Body TSL	condition	
SAR measured	100 mW input power	2.12 W/kg
SAR for nominal Body TSL parameters	normalized to 1W	21.0 W/kg ± 19.5 % (k=2)

Body TSL parameters at 5300 MHz

The following parameters and calculations were applied.

	Temperature	Permittivity	Conductivity
Nominal Body TSL parameters	22.0 °C	48.9	5.42 mho/m
Measured Body TSL parameters	(22.0 ± 0.2) °C	47.2 ± 6 %	5.57 mho/m ± 6 %
Body TSL temperature change during test	< 0.5 °C	----	----

SAR result with Body TSL at 5300 MHz

SAR averaged over 1 cm ³ (1 g) of Body TSL	Condition	
SAR measured	100 mW input power	7.79 W/kg
SAR for nominal Body TSL parameters	normalized to 1W	77.4 W/kg ± 19.9 % (k=2)

SAR averaged over 10 cm ³ (10 g) of Body TSL	condition	
SAR measured	100 mW input power	2.17 W/kg
SAR for nominal Body TSL parameters	normalized to 1W	21.5 W/kg ± 19.5 % (k=2)

Body TSL parameters at 5500 MHz

The following parameters and calculations were applied.

	Temperature	Permittivity	Conductivity
Nominal Body TSL parameters	22.0 °C	48.6	5.65 mho/m
Measured Body TSL parameters	(22.0 ± 0.2) °C	46.8 ± 6 %	5.84 mho/m ± 6 %
Body TSL temperature change during test	< 0.5 °C	----	----

SAR result with Body TSL at 5500 MHz

SAR averaged over 1 cm ³ (1 g) of Body TSL	Condition	
SAR measured	100 mW input power	7.96 W/kg
SAR for nominal Body TSL parameters	normalized to 1W	79.1 W/kg ± 19.9 % (k=2)

SAR averaged over 10 cm ³ (10 g) of Body TSL	condition	
SAR measured	100 mW input power	2.22 W/kg
SAR for nominal Body TSL parameters	normalized to 1W	22.0 W/kg ± 19.5 % (k=2)

Body TSL parameters at 5600 MHz

The following parameters and calculations were applied.

	Temperature	Permittivity	Conductivity
Nominal Body TSL parameters	22.0 °C	48.5	5.77 mho/m
Measured Body TSL parameters	(22.0 ± 0.2) °C	46.6 ± 6 %	5.98 mho/m ± 6 %
Body TSL temperature change during test	< 0.5 °C	----	----

SAR result with Body TSL at 5600 MHz

SAR averaged over 1 cm ³ (1 g) of Body TSL	Condition	
SAR measured	100 mW input power	8.07 W/kg
SAR for nominal Body TSL parameters	normalized to 1W	80.2 W/kg ± 19.9 % (k=2)

SAR averaged over 10 cm ³ (10 g) of Body TSL	condition	
SAR measured	100 mW input power	2.24 W/kg
SAR for nominal Body TSL parameters	normalized to 1W	22.2 W/kg ± 19.5 % (k=2)

Body TSL parameters at 5800 MHz

The following parameters and calculations were applied.

	Temperature	Permittivity	Conductivity
Nominal Body TSL parameters	22.0 °C	48.2	6.00 mho/m
Measured Body TSL parameters	(22.0 ± 0.2) °C	46.3 ± 6 %	6.23 mho/m ± 6 %
Body TSL temperature change during test	< 0.5 °C	----	----

SAR result with Body TSL at 5800 MHz

SAR averaged over 1 cm ³ (1 g) of Body TSL	Condition	
SAR measured	100 mW input power	7.48 W/kg
SAR for nominal Body TSL parameters	normalized to 1W	74.3 W/kg ± 19.9 % (k=2)

SAR averaged over 10 cm ³ (10 g) of Body TSL	condition	
SAR measured	100 mW input power	2.06 W/kg
SAR for nominal Body TSL parameters	normalized to 1W	20.4 W/kg ± 19.5 % (k=2)

Appendix

Antenna Parameters with Head TSL at 5200 MHz

Impedance, transformed to feed point	43.1 Ω - 4.6 j Ω
Return Loss	- 21.0 dB

Antenna Parameters with Head TSL at 5300 MHz

Impedance, transformed to feed point	46.5 Ω - 1.3 j Ω
Return Loss	- 28.1 dB

Antenna Parameters with Head TSL at 5500 MHz

Impedance, transformed to feed point	46.2 Ω - 2.5 j Ω
Return Loss	- 26.4 dB

Antenna Parameters with Head TSL at 5600 MHz

Impedance, transformed to feed point	48.9 Ω - 5.7 j Ω
Return Loss	- 24.6 dB

Antenna Parameters with Head TSL at 5800 MHz

Impedance, transformed to feed point	48.7 Ω - 3.1 j Ω
Return Loss	- 29.5 dB

Antenna Parameters with Body TSL at 5200 MHz

Impedance, transformed to feed point	49.4 Ω - 7.7 j Ω
Return Loss	- 22.2 dB

Antenna Parameters with Body TSL at 5300 MHz

Impedance, transformed to feed point	49.6 Ω - 3.0 j Ω
Return Loss	- 30.3 dB

Antenna Parameters with Body TSL at 5500 MHz

Impedance, transformed to feed point	50.8 Ω - 3.9 j Ω
Return Loss	- 28.0 dB

Antenna Parameters with Body TSL at 5600 MHz

Impedance, transformed to feed point	55.4 Ω - 2.5 j Ω
Return Loss	- 25.0 dB

Antenna Parameters with Body TSL at 5800 MHz

Impedance, transformed to feed point	52.3 Ω - 0.7 j Ω
Return Loss	- 32.5 dB

General Antenna Parameters and Design

Electrical Delay (one direction)	1.186 ns
----------------------------------	----------

After long term use with 100W radiated power, only a slight warming of the dipole near the feedpoint can be measured.

The dipole is made of standard semirigid coaxial cable. The center conductor of the feeding line is directly connected to the second arm of the dipole. The antenna is therefore short-circuited for DC-signals. On some of the dipoles, small end caps are added to the dipole arms in order to improve matching when loaded according to the position as explained in the "Measurement Conditions" paragraph. The SAR data are not affected by this change. The overall dipole length is still according to the Standard.

No excessive force must be applied to the dipole arms, because they might bend or the soldered connections near the feedpoint may be damaged.

Additional EUT Data

Manufactured by	SPEAG
Manufactured on	November 27, 2006

DASY5 Validation Report for Head TSL

Date: 27.01.2014

Test Laboratory: SPEAG, Zurich, Switzerland

DUT: Dipole 5GHz; Type: D5GHzV2; Serial: D5GHzV2 - SN: 1057

Communication System: UID 0 - CW; Frequency: 5200 MHz, Frequency: 5300 MHz, Frequency: 5500 MHz, Frequency: 5600 MHz, Frequency: 5800 MHz

Medium parameters used: $f = 5200$ MHz; $\sigma = 4.45$ S/m; $\epsilon_r = 35$; $\rho = 1000$ kg/m³, Medium parameters used: $f = 5300$ MHz; $\sigma = 4.54$ S/m; $\epsilon_r = 34.9$; $\rho = 1000$ kg/m³, Medium parameters used: $f = 5500$ MHz; $\sigma = 4.74$ S/m; $\epsilon_r = 34.6$; $\rho = 1000$ kg/m³, Medium parameters used: $f = 5600$ MHz; $\sigma = 4.86$ S/m; $\epsilon_r = 34.5$; $\rho = 1000$ kg/m³, Medium parameters used: $f = 5800$ MHz; $\sigma = 5.07$ S/m; $\epsilon_r = 34.2$; $\rho = 1000$ kg/m³

Phantom section: Flat Section

Measurement Standard: DASY5 (IEEE/IEC/ANSI C63.19-2007)

DASY52 Configuration:

- Probe: EX3DV4 - SN3503; ConvF(5.52, 5.52, 5.52); Calibrated: 30.12.2013, ConvF(5.2, 5.2, 5.2); Calibrated: 30.12.2013, ConvF(5.01, 5.01, 5.01); Calibrated: 30.12.2013, ConvF(4.86, 4.86, 4.86); Calibrated: 30.12.2013, ConvF(4.91, 4.91, 4.91); Calibrated: 30.12.2013;
- Sensor-Surface: 1.4mm (Mechanical Surface Detection)
- Electronics: DAE4 Sn601; Calibrated: 25.04.2013
- Phantom: Flat Phantom 5.0 (front); Type: QD000P50AA; Serial: 1001
- DASY52 52.8.7(1137); SEMCAD X 14.6.10(7164)

Dipole Calibration for Head Tissue/Pin=100mW, dist=10mm, f=5200 MHz/Zoom Scan,

dist=1.4mm (8x8x7)/Cube 0: Measurement grid: dx=4mm, dy=4mm, dz=1.4mm

Reference Value = 63.497 V/m; Power Drift = 0.04 dB

Peak SAR (extrapolated) = 28.2 W/kg

SAR(1 g) = 7.85 W/kg; SAR(10 g) = 2.25 W/kg

Maximum value of SAR (measured) = 18.6 W/kg

Dipole Calibration for Head Tissue/Pin=100mW, dist=10mm, f=5300 MHz/Zoom Scan,

dist=1.4mm (8x8x7)/Cube 0: Measurement grid: dx=4mm, dy=4mm, dz=1.4mm

Reference Value = 64.444 V/m; Power Drift = 0.07 dB

Peak SAR (extrapolated) = 31.2 W/kg

SAR(1 g) = 8.36 W/kg; SAR(10 g) = 2.4 W/kg

Maximum value of SAR (measured) = 20.1 W/kg

Dipole Calibration for Head Tissue/Pin=100mW, dist=10mm, f=5500 MHz/Zoom Scan,

dist=1.4mm (8x8x7)/Cube 0: Measurement grid: dx=4mm, dy=4mm, dz=1.4mm

Reference Value = 63.807 V/m; Power Drift = 0.07 dB

Peak SAR (extrapolated) = 33.0 W/kg

SAR(1 g) = 8.5 W/kg; SAR(10 g) = 2.42 W/kg

Maximum value of SAR (measured) = 20.8 W/kg

Dipole Calibration for Head Tissue/Pin=100mW, dist=10mm, f=5600 MHz/Zoom Scan, dist=1.4mm (8x8x7)/Cube 0: Measurement grid: dx=4mm, dy=4mm, dz=1.4mm
Reference Value = 63.194 V/m; Power Drift = 0.06 dB
Peak SAR (extrapolated) = 33.2 W/kg
SAR(1 g) = 8.42 W/kg; SAR(10 g) = 2.4 W/kg

Dipole Calibration for Head Tissue/Pin=100mW, dist=10mm, f=5800 MHz/Zoom Scan, dist=1.4mm (8x8x7)/Cube 0: Measurement grid: dx=4mm, dy=4mm, dz=1.4mm
Reference Value = 60.646 V/m; Power Drift = 0.08 dB
Peak SAR (extrapolated) = 32.9 W/kg
SAR(1 g) = 8 W/kg; SAR(10 g) = 2.28 W/kg
Maximum value of SAR (measured) = 19.9 W/kg

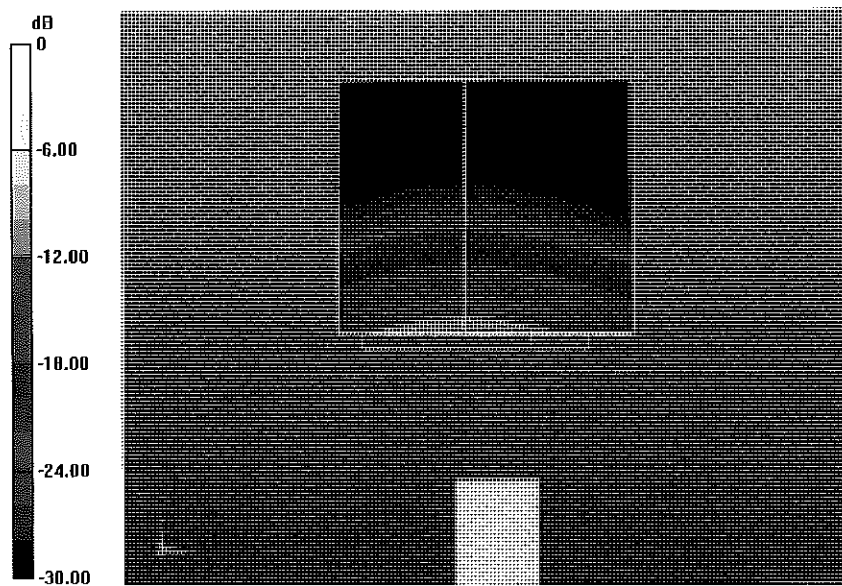

0 dB = 19.9 W/kg = 12.99 dBW/kg

Impedance Measurement Plot for Head TSL

27 Jan 2014 17:12:04

CH1 S11 1 U FS

1: 43.092 Ω -4.5938 Ω 6.6627 pF

5 200.000 000 MHz

*
De1
Cor
Avg
16
H1d

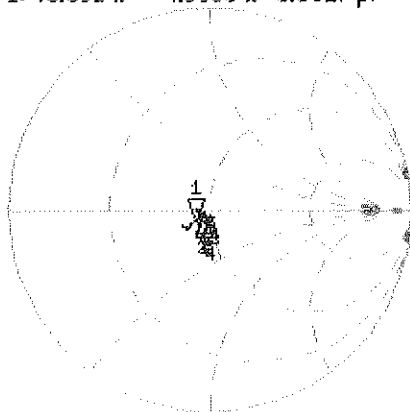

CH1 Markers

- 2: 46.475 Ω
-1.3496 Ω
5.30000 GHz
- 3: 46.150 Ω
-2.5078 Ω
5.50000 GHz
- 4: 48.900 Ω
-5.6992 Ω
5.60000 GHz
- 5: 48.734 Ω
-3.0762 Ω
5.80000 GHz

CH2 S11 LOG 5 dB/REF -20 dB 1:-21.014 dB 5 200.000 000 MHz

De1
Cor
Avg
16
H1d

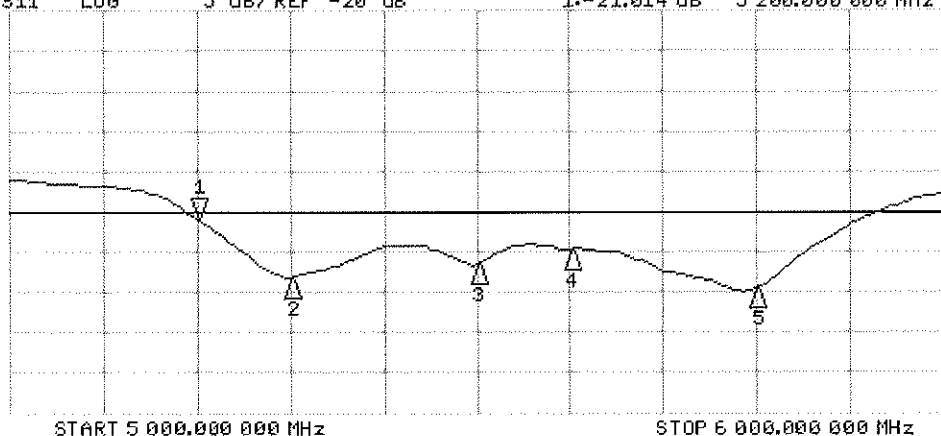

CH2 Markers

- 2: -28.145 dB
5.30000 GHz
- 3: -26.415 dB
5.50000 GHz
- 4: -24.640 dB
5.60000 GHz
- 5: -29.464 dB
5.80000 GHz

START 5 000.000 000 MHz

STOP 6 000.000 000 MHz

DASY5 Validation Report for Body TSL

Date: 24.01.2014

Test Laboratory: SPEAG, Zurich, Switzerland

DUT: Dipole 5GHz; Type: D5GHzV2; Serial: D5GHzV2 - SN: 1057

Communication System: UID 0 - CW; Frequency: 5200 MHz, Frequency: 5300 MHz, Frequency: 5500 MHz, Frequency: 5600 MHz, Frequency: 5800 MHz

Medium parameters used: $f = 5200$ MHz; $\sigma = 5.44$ S/m; $\epsilon_r = 47.3$; $\rho = 1000$ kg/m³, Medium parameters used: $f = 5300$ MHz; $\sigma = 5.57$ S/m; $\epsilon_r = 47.2$; $\rho = 1000$ kg/m³, Medium parameters used: $f = 5500$ MHz; $\sigma = 5.84$ S/m; $\epsilon_r = 46.8$; $\rho = 1000$ kg/m³, Medium parameters used: $f = 5600$ MHz; $\sigma = 5.98$ S/m; $\epsilon_r = 46.6$; $\rho = 1000$ kg/m³, Medium parameters used: $f = 5800$ MHz; $\sigma = 6.23$ S/m; $\epsilon_r = 46.3$; $\rho = 1000$ kg/m³

Phantom section: Flat Section

Measurement Standard: DASY5 (IEEE/IEC/ANSI C63.19-2007)

DASY52 Configuration:

- Probe: EX3DV4 - SN3503; ConvF(5.01, 5.01, 5.01); Calibrated: 30.12.2013, ConvF(4.76, 4.76, 4.76); Calibrated: 30.12.2013, ConvF(4.52, 4.52, 4.52); Calibrated: 30.12.2013, ConvF(4.3, 4.3, 4.3); Calibrated: 30.12.2013, ConvF(4.47, 4.47, 4.47); Calibrated: 30.12.2013;
- Sensor-Surface: 1.4mm (Mechanical Surface Detection)
- Electronics: DAE4 Sn601; Calibrated: 25.04.2013
- Phantom: Flat Phantom 5.0 (back); Type: QD000P50AA; Serial: 1002
- DASY52 52.8.7(1137); SEMCAD X 14.6.10(7164)

Dipole Calibration for Body Tissue/Pin=100mW, dist=10mm, f=5200 MHz/Zoom Scan, dist=1.4mm (8x8x7)/Cube 0: Measurement grid: dx=4mm, dy=4mm, dz=1.4mm

Reference Value = 58.809 V/m; Power Drift = -0.05 dB

Peak SAR (extrapolated) = 30.1 W/kg

SAR(1 g) = 7.58 W/kg; SAR(10 g) = 2.12 W/kg

Maximum value of SAR (measured) = 18.2 W/kg

Dipole Calibration for Body Tissue/Pin=100mW, dist=10mm, f=5300 MHz/Zoom Scan, dist=1.4mm (8x8x7)/Cube 0: Measurement grid: dx=4mm, dy=4mm, dz=1.4mm

Reference Value = 58.585 V/m; Power Drift = -0.00 dB

Peak SAR (extrapolated) = 32.2 W/kg

SAR(1 g) = 7.79 W/kg; SAR(10 g) = 2.17 W/kg

Maximum value of SAR (measured) = 19.1 W/kg

Dipole Calibration for Body Tissue/Pin=100mW, dist=10mm, f=5500 MHz/Zoom Scan, dist=1.4mm (8x8x7)/Cube 0: Measurement grid: dx=4mm, dy=4mm, dz=1.4mm

Reference Value = 58.364 V/m; Power Drift = -0.01 dB

Peak SAR (extrapolated) = 34.4 W/kg

SAR(1 g) = 7.96 W/kg; SAR(10 g) = 2.22 W/kg

Maximum value of SAR (measured) = 19.4 W/kg

Dipole Calibration for Body Tissue/Pin=100mW, dist=10mm, f=5600 MHz/Zoom Scan, dist=1.4mm (8x8x7)/Cube 0: Measurement grid: dx=4mm, dy=4mm, dz=1.4mm

Reference Value = 57.864 V/m; Power Drift = 0.01 dB

Peak SAR (extrapolated) = 35.8 W/kg

SAR(1 g) = 8.07 W/kg; SAR(10 g) = 2.24 W/kg

Maximum value of SAR (measured) = 19.8 W/kg

Dipole Calibration for Body Tissue/Pin=100mW, dist=10mm, f=5800 MHz/Zoom Scan, dist=1.4mm (8x8x7)/Cube 0: Measurement grid: dx=4mm, dy=4mm, dz=1.4mm

Reference Value = 54.817 V/m; Power Drift = -0.01 dB

Peak SAR (extrapolated) = 35.1 W/kg

SAR(1 g) = 7.48 W/kg; SAR(10 g) = 2.06 W/kg

Maximum value of SAR (measured) = 18.8 W/kg

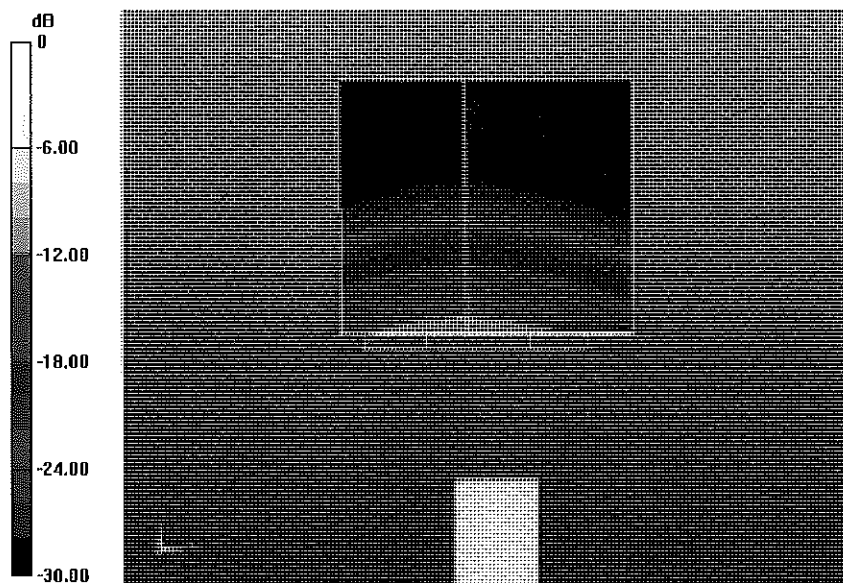

0 dB = 18.8 W/kg = 12.74 dBW/kg

Impedance Measurement Plot for Body TSL

24 Jan 2014 15:50:22

CH1 S11 1 U FS 1: 49.354 Ω -7.7188 Ω 3.9652 pF 5 200.000 000 MHz

*
De1
Cor
Avg
16
H1d

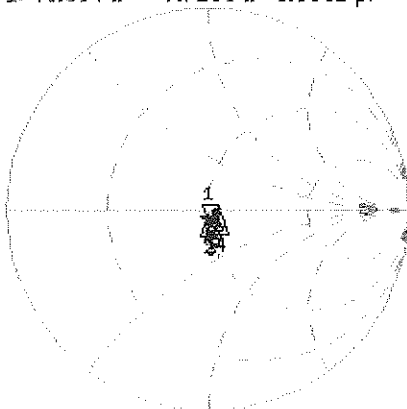

CH1 Markers
2: 49.559 Ω
-3.0176 Ω
5.30000 GHz
3: 50.793 Ω
-3.9160 Ω
5.50000 GHz
4: 55.393 Ω
-2.5176 Ω
5.60000 GHz
5: 52.320 Ω
-716.80 m Ω
5.80000 GHz

CH2 S11 L06 5 dB/REF -20 dB 1:-22.190 dB 5 200.000 000 MHz

Cor
Avg
16
H1d

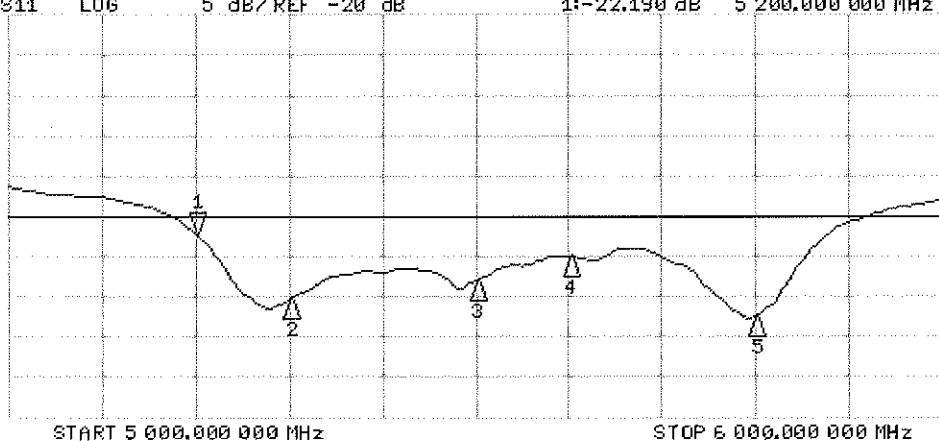

CH2 Markers
2:-30.277 dB
5.30000 GHz
3:-28.039 dB
5.50000 GHz
4:-24.950 dB
5.60000 GHz
5:-32.401 dB
5.80000 GHz



Accredited by the Swiss Accreditation Service (SAS)
The Swiss Accreditation Service is one of the signatories to the EA
Multilateral Agreement for the recognition of calibration certificates

Accreditation No.: **SCS 108**

Client **PC Test**

Certificate No: **D835V2-4d119_Apr14**

CALIBRATION CERTIFICATE

Object **D835V2 - SN: 4d119**

Calibration procedure(s) **QA CAL-05.v9
Calibration procedure for dipole validation kits above 700 MHz**

*CCV
4/25/14*

Calibration date: **April 07, 2014**

This calibration certificate documents the traceability to national standards, which realize the physical units of measurements (SI).
The measurements and the uncertainties with confidence probability are given on the following pages and are part of the certificate.

All calibrations have been conducted in the closed laboratory facility: environment temperature (22 ± 3)°C and humidity < 70%.

Calibration Equipment used (M&TE critical for calibration)

Primary Standards	ID #	Cal Date (Certificate No.)	Scheduled Calibration
Power meter EPM-442A	GB37480704	09-Oct-13 (No. 217-01827)	Oct-14
Power sensor HP 8481A	US37292783	09-Oct-13 (No. 217-01827)	Oct-14
Power sensor HP 8481A	MY41092317	09-Oct-13 (No. 217-01828)	Oct-14
Reference 20 dB Attenuator	SN: 5058 (20k)	03-Apr-14 (No. 217-01918)	Apr-15
Type-N mismatch combination	SN: 5047.2 / 06327	03-Apr-14 (No. 217-01921)	Apr-15
Reference Probe ES3DV3	SN: 3205	30-Dec-13 (No. ES3-3205_Dec13)	Dec-14
DAE4	SN: 601	25-Apr-13 (No. DAE4-601_Apr13)	Apr-14
Secondary Standards	ID #	Check Date (in house)	Scheduled Check
RF generator R&S SMT-06	100005	04-Aug-99 (in house check Oct-13)	In house check: Oct-16
Network Analyzer HP 8753E	US37390585 S4206	18-Oct-01 (in house check Oct-13)	In house check: Oct-14

Calibrated by: **Name** Leif Klysner **Function** Laboratory Technician **Signature** *Leif Klysner*

Approved by: **Name** Katja Pokovic **Function** Technical Manager *Katja Pokovic*

Issued: April 9, 2014

This calibration certificate shall not be reproduced except in full without written approval of the laboratory.



Accredited by the Swiss Accreditation Service (SAS)
The Swiss Accreditation Service is one of the signatories to the EA
Multilateral Agreement for the recognition of calibration certificates

Accreditation No.: **SCS 108**

Glossary:

TSL	tissue simulating liquid
ConvF	sensitivity in TSL / NORM x,y,z
N/A	not applicable or not measured

Calibration is Performed According to the Following Standards:

- a) IEEE Std 1528-2013, "IEEE Recommended Practice for Determining the Peak Spatial-Averaged Specific Absorption Rate (SAR) in the Human Head from Wireless Communications Devices: Measurement Techniques", June 2013
- b) IEC 62209-1, "Procedure to measure the Specific Absorption Rate (SAR) for hand-held devices used in close proximity to the ear (frequency range of 300 MHz to 3 GHz)", February 2005
- c) KDB 865664, "SAR Measurement Requirements for 100 MHz to 6 GHz"

Additional Documentation:

- d) DASY4/5 System Handbook

Methods Applied and Interpretation of Parameters:

- *Measurement Conditions:* Further details are available from the Validation Report at the end of the certificate. All figures stated in the certificate are valid at the frequency indicated.
- *Antenna Parameters with TSL:* The dipole is mounted with the spacer to position its feed point exactly below the center marking of the flat phantom section, with the arms oriented parallel to the body axis.
- *Feed Point Impedance and Return Loss:* These parameters are measured with the dipole positioned under the liquid filled phantom. The impedance stated is transformed from the measurement at the SMA connector to the feed point. The Return Loss ensures low reflected power. No uncertainty required.
- *Electrical Delay:* One-way delay between the SMA connector and the antenna feed point. No uncertainty required.
- *SAR measured:* SAR measured at the stated antenna input power.
- *SAR normalized:* SAR as measured, normalized to an input power of 1 W at the antenna connector.
- *SAR for nominal TSL parameters:* The measured TSL parameters are used to calculate the nominal SAR result.

The reported uncertainty of measurement is stated as the standard uncertainty of measurement multiplied by the coverage factor $k=2$, which for a normal distribution corresponds to a coverage probability of approximately 95%.

Measurement Conditions

DASY system configuration, as far as not given on page 1.

DASY Version	DASY5	V52.8.7
Extrapolation	Advanced Extrapolation	
Phantom	Modular Flat Phantom	
Distance Dipole Center - TSL	15 mm	with Spacer
Zoom Scan Resolution	dx, dy, dz = 5 mm	
Frequency	835 MHz \pm 1 MHz	

Head TSL parameters

The following parameters and calculations were applied.

	Temperature	Permittivity	Conductivity
Nominal Head TSL parameters	22.0 °C	41.5	0.90 mho/m
Measured Head TSL parameters	(22.0 \pm 0.2) °C	41.6 \pm 6 %	0.94 mho/m \pm 6 %
Head TSL temperature change during test	< 0.5 °C	----	----

SAR result with Head TSL

SAR averaged over 1 cm ³ (1 g) of Head TSL	Condition	
SAR measured	250 mW input power	2.38 W/kg
SAR for nominal Head TSL parameters	normalized to 1W	9.22 W/kg \pm 17.0 % (k=2)

SAR averaged over 10 cm ³ (10 g) of Head TSL	condition	
SAR measured	250 mW input power	1.53 W/kg
SAR for nominal Head TSL parameters	normalized to 1W	5.97 W/kg \pm 16.5 % (k=2)

Body TSL parameters

The following parameters and calculations were applied.

	Temperature	Permittivity	Conductivity
Nominal Body TSL parameters	22.0 °C	55.2	0.97 mho/m
Measured Body TSL parameters	(22.0 \pm 0.2) °C	53.6 \pm 6 %	1.02 mho/m \pm 6 %
Body TSL temperature change during test	< 0.5 °C	----	----

SAR result with Body TSL

SAR averaged over 1 cm ³ (1 g) of Body TSL	Condition	
SAR measured	250 mW input power	2.44 W/kg
SAR for nominal Body TSL parameters	normalized to 1W	9.34 W/kg \pm 17.0 % (k=2)

SAR averaged over 10 cm ³ (10 g) of Body TSL	condition	
SAR measured	250 mW input power	1.59 W/kg
SAR for nominal Body TSL parameters	normalized to 1W	6.15 W/kg \pm 16.5 % (k=2)

Appendix

Antenna Parameters with Head TSL

Impedance, transformed to feed point	51.2 Ω - 1.6 j Ω
Return Loss	- 34.0 dB

Antenna Parameters with Body TSL

Impedance, transformed to feed point	46.3 Ω - 4.5 j Ω
Return Loss	- 24.4 dB

General Antenna Parameters and Design

Electrical Delay (one direction)	1.386 ns
----------------------------------	----------

After long term use with 100W radiated power, only a slight warming of the dipole near the feedpoint can be measured.

The dipole is made of standard semirigid coaxial cable. The center conductor of the feeding line is directly connected to the second arm of the dipole. The antenna is therefore short-circuited for DC-signals. On some of the dipoles, small end caps are added to the dipole arms in order to improve matching when loaded according to the position as explained in the "Measurement Conditions" paragraph. The SAR data are not affected by this change. The overall dipole length is still according to the Standard.

No excessive force must be applied to the dipole arms, because they might bend or the soldered connections near the feedpoint may be damaged.

Additional EUT Data

Manufactured by	SPEAG
Manufactured on	June 29, 2010

DASY5 Validation Report for Head TSL

Date: 07.04.2014

Test Laboratory: SPEAG, Zurich, Switzerland

DUT: Dipole 835 MHz; Type: D835V2; Serial: D835V2 - SN: 4d119

Communication System: UID 0 - CW; Frequency: 835 MHz

Medium parameters used: $f = 835$ MHz; $\sigma = 0.94$ S/m; $\epsilon_r = 41.6$; $\rho = 1000$ kg/m³

Phantom section: Flat Section

Measurement Standard: DASY5 (IEEE/IEC/ANSI C63.19-2007)

DASY52 Configuration:

- Probe: ES3DV3 - SN3205; ConvF(6.22, 6.22, 6.22); Calibrated: 30.12.2013;
- Sensor-Surface: 3mm (Mechanical Surface Detection)
- Electronics: DAE4 Sn601; Calibrated: 25.04.2013
- Phantom: Flat Phantom 4.9L; Type: QD000P49AA; Serial: 1001
- DASY52 52.8.7(1137); SEMCAD X 14.6.10(7164)

Dipole Calibration for Head Tissue/Pin=250 mW, d=15mm/Zoom Scan (7x7x7)/Cube 0:

Measurement grid: dx=5mm, dy=5mm, dz=5mm

Reference Value = 56.289 V/m; Power Drift = 0.01 dB

Peak SAR (extrapolated) = 3.59 W/kg

SAR(1 g) = 2.38 W/kg; SAR(10 g) = 1.53 W/kg

Maximum value of SAR (measured) = 2.80 W/kg

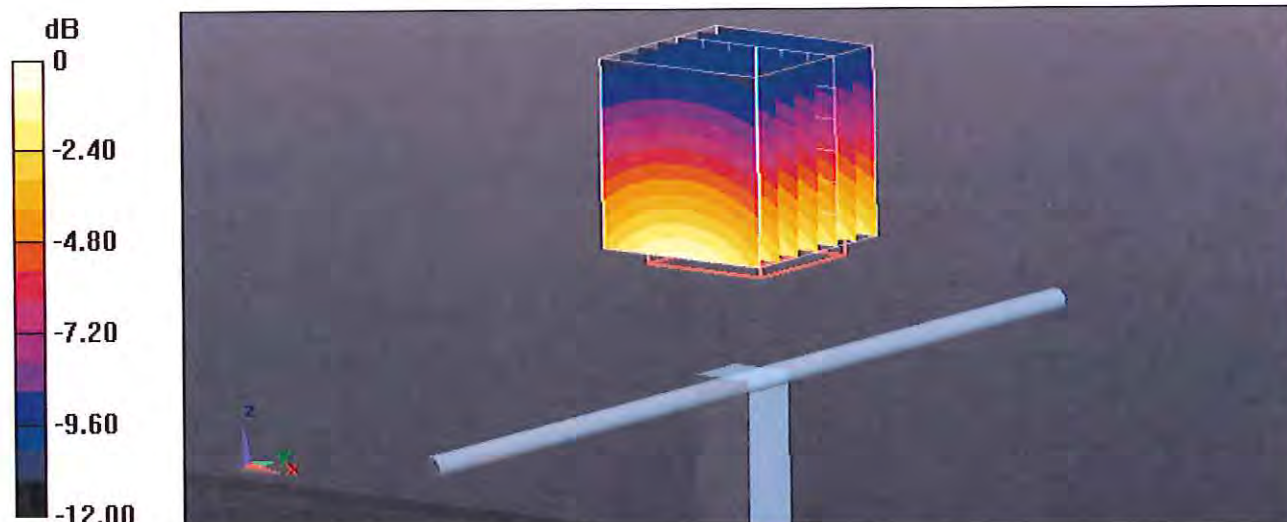

Impedance Measurement Plot for Head TSL

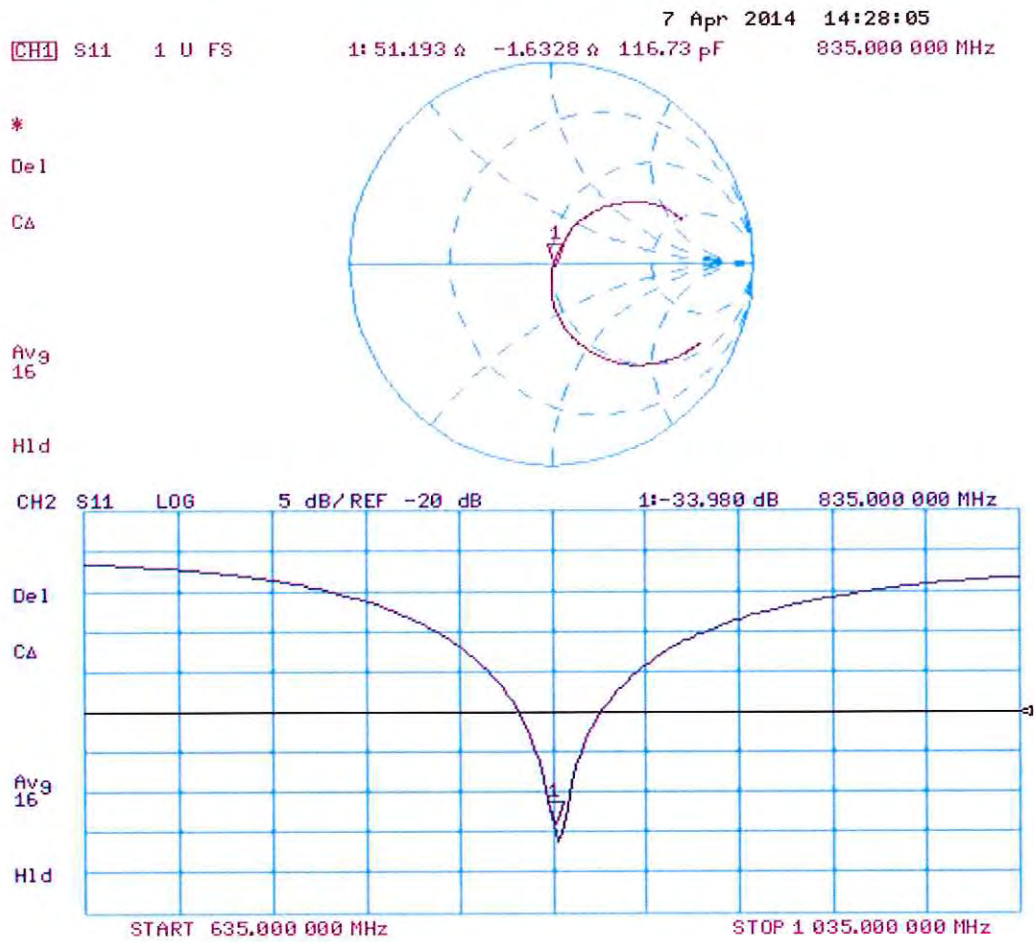

DASY5 Validation Report for Body TSL

Date: 07.04.2014

Test Laboratory: SPEAG, Zurich, Switzerland

DUT: Dipole 835 MHz; Type: D835V2; Serial: D835V2 - SN: 4d119

Communication System: UID 0 - CW; Frequency: 835 MHz

Medium parameters used: $f = 835$ MHz; $\sigma = 1.02$ S/m; $\epsilon_r = 53.6$; $\rho = 1000$ kg/m³

Phantom section: Flat Section

Measurement Standard: DASY5 (IEEE/IEC/ANSI C63.19-2007)

DASY52 Configuration:

- Probe: ES3DV3 - SN3205; ConvF(6.09, 6.09, 6.09); Calibrated: 30.12.2013;
- Sensor-Surface: 3mm (Mechanical Surface Detection)
- Electronics: DAE4 Sn601; Calibrated: 25.04.2013
- Phantom: Flat Phantom 4.9L; Type: QD000P49AA; Serial: 1001
- DASY52 52.8.7(1137); SEMCAD X 14.6.10(7164)

Dipole Calibration for Body Tissue/Pin=250 mW, d=15mm/Zoom Scan (7x7x7)/Cube 0:

Measurement grid: dx=5mm, dy=5mm, dz=5mm

Reference Value = 54.594 V/m; Power Drift = -0.01 dB

Peak SAR (extrapolated) = 3.61 W/kg

SAR(1 g) = 2.44 W/kg; SAR(10 g) = 1.59 W/kg

Maximum value of SAR (measured) = 2.85 W/kg

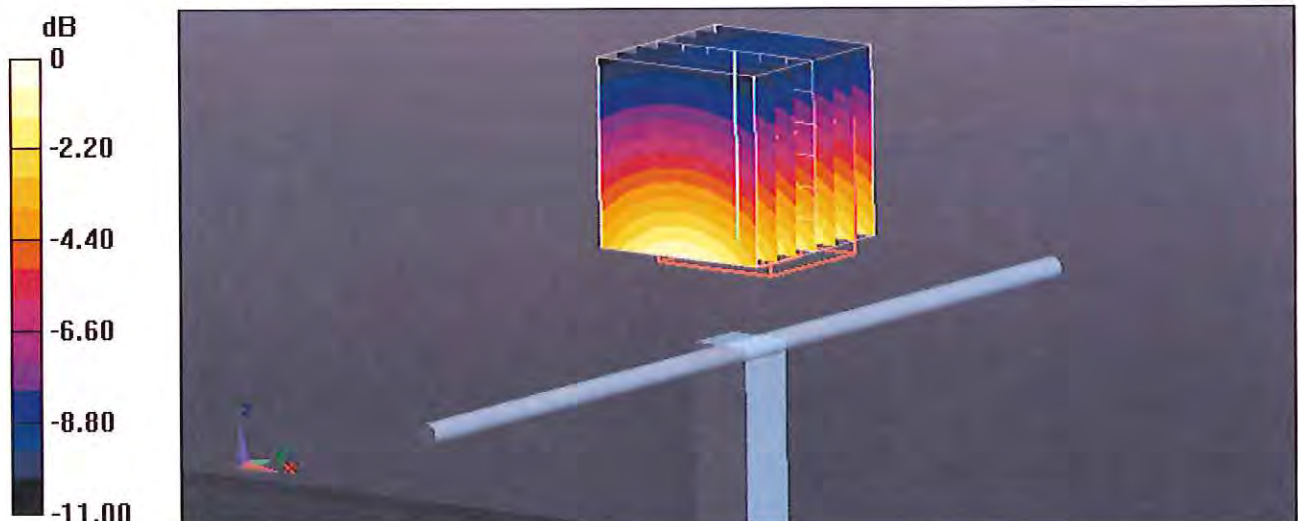

Impedance Measurement Plot for Body TSL

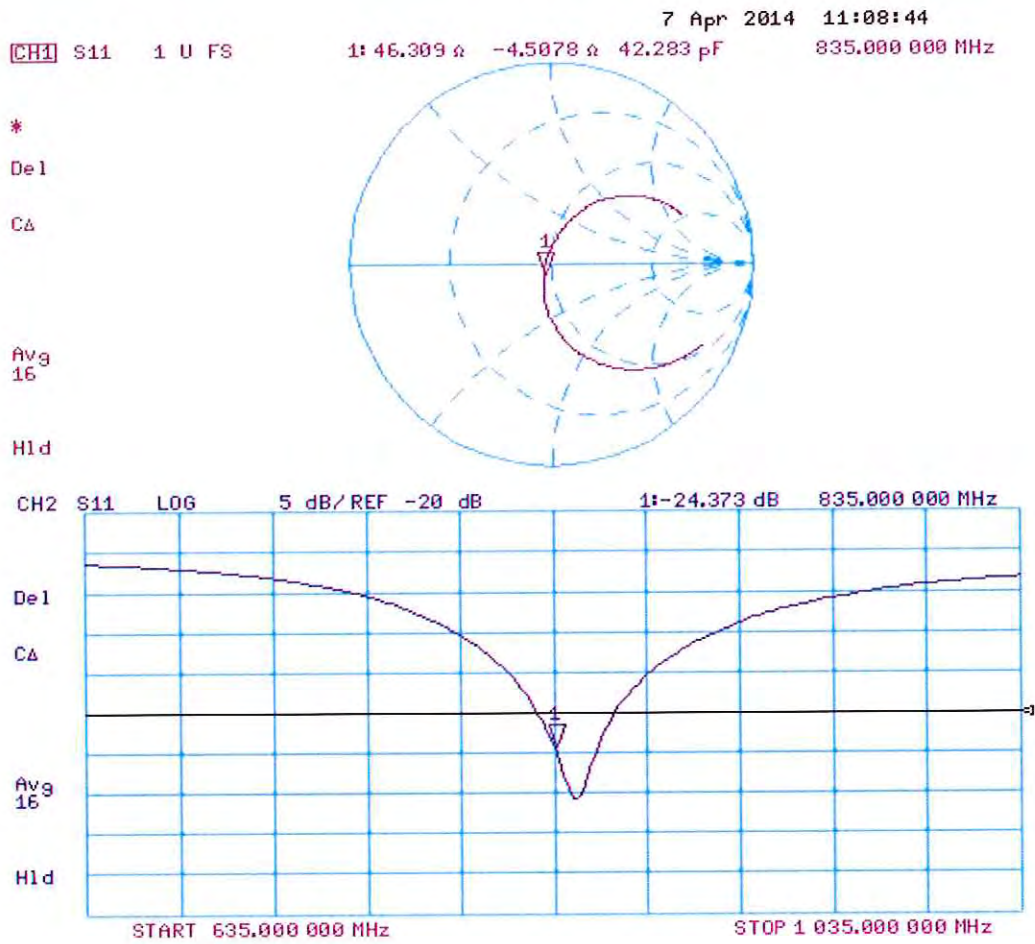



Accredited by the Swiss Accreditation Service (SAS)
The Swiss Accreditation Service is one of the signatories to the EA
Multilateral Agreement for the recognition of calibration certificates

Accreditation No.: **SCS 108**

Client **PC Test**

Certificate No: **D835V2-4d132_Jul14**

CALIBRATION CERTIFICATE

Object **D835V2 - SN: 4d132**

Calibration procedure(s) **QA CAL-05.v9
Calibration procedure for dipole validation kits above 700 MHz**

Calibration date: **July 10, 2014**

✓
KOK
7/17/14

This calibration certificate documents the traceability to national standards, which realize the physical units of measurements (SI).
The measurements and the uncertainties with confidence probability are given on the following pages and are part of the certificate.

All calibrations have been conducted in the closed laboratory facility: environment temperature (22 ± 3)°C and humidity < 70%.

Calibration Equipment used (M&TE critical for calibration)

Primary Standards	ID #	Cal Date (Certificate No.)	Scheduled Calibration
Power meter EPM-442A	GB37480704	09-Oct-13 (No. 217-01827)	Oct-14
Power sensor HP 8481A	US37292783	09-Oct-13 (No. 217-01827)	Oct-14
Power sensor HP 8481A	MY41092317	09-Oct-13 (No. 217-01828)	Oct-14
Reference 20 dB Attenuator	SN: 5058 (20k)	03-Apr-14 (No. 217-01918)	Apr-15
Type-N mismatch combination	SN: 5047.2 / 06327	03-Apr-14 (No. 217-01921)	Apr-15
Reference Probe ES3DV3	SN: 3205	30-Dec-13 (No. ES3-3205_Dec13)	Dec-14
DAE4	SN: 601	30-Apr-14 (No. DAE4-601_Apr14)	Apr-15
Secondary Standards	ID #	Check Date (in house)	Scheduled Check
RF generator R&S SMT-06	100005	04-Aug-99 (in house check Oct-13)	In house check: Oct-16
Network Analyzer HP 8753E	US37390585 S4206	18-Oct-01 (in house check Oct-13)	In house check: Oct-14

Calibrated by: **Michael Weber** Function: **Laboratory Technician**

Signature

Approved by: **Katja Pokovic** Technical Manager

Issued: July 11, 2014

This calibration certificate shall not be reproduced except in full without written approval of the laboratory.



Accredited by the Swiss Accreditation Service (SAS)
The Swiss Accreditation Service is one of the signatories to the EA
Multilateral Agreement for the recognition of calibration certificates

Accreditation No.: **SCS 108**

Glossary:

TSL	tissue simulating liquid
ConvF	sensitivity in TSL / NORM x,y,z
N/A	not applicable or not measured

Calibration is Performed According to the Following Standards:

- IEEE Std 1528-2013, "IEEE Recommended Practice for Determining the Peak Spatial-Averaged Specific Absorption Rate (SAR) in the Human Head from Wireless Communications Devices: Measurement Techniques", June 2013
- IEC 62209-1, "Procedure to measure the Specific Absorption Rate (SAR) for hand-held devices used in close proximity to the ear (frequency range of 300 MHz to 3 GHz)", February 2005
- KDB 865664, "SAR Measurement Requirements for 100 MHz to 6 GHz"

Additional Documentation:

- DASY4/5 System Handbook

Methods Applied and Interpretation of Parameters:

- Measurement Conditions:* Further details are available from the Validation Report at the end of the certificate. All figures stated in the certificate are valid at the frequency indicated.
- Antenna Parameters with TSL:* The dipole is mounted with the spacer to position its feed point exactly below the center marking of the flat phantom section, with the arms oriented parallel to the body axis.
- Feed Point Impedance and Return Loss:* These parameters are measured with the dipole positioned under the liquid filled phantom. The impedance stated is transformed from the measurement at the SMA connector to the feed point. The Return Loss ensures low reflected power. No uncertainty required.
- Electrical Delay:* One-way delay between the SMA connector and the antenna feed point. No uncertainty required.
- SAR measured:* SAR measured at the stated antenna input power.
- SAR normalized:* SAR as measured, normalized to an input power of 1 W at the antenna connector.
- SAR for nominal TSL parameters:* The measured TSL parameters are used to calculate the nominal SAR result.

The reported uncertainty of measurement is stated as the standard uncertainty of measurement multiplied by the coverage factor $k=2$, which for a normal distribution corresponds to a coverage probability of approximately 95%.

Measurement Conditions

DASY system configuration, as far as not given on page 1.

DASY Version	DASY5	V52.8.8
Extrapolation	Advanced Extrapolation	
Phantom	Modular Flat Phantom	
Distance Dipole Center - TSL	15 mm	with Spacer
Zoom Scan Resolution	dx, dy, dz = 5 mm	
Frequency	835 MHz \pm 1 MHz	

Head TSL parameters

The following parameters and calculations were applied.

	Temperature	Permittivity	Conductivity
Nominal Head TSL parameters	22.0 °C	41.5	0.90 mho/m
Measured Head TSL parameters	(22.0 \pm 0.2) °C	41.1 \pm 6 %	0.94 mho/m \pm 6 %
Head TSL temperature change during test	< 0.5 °C	----	----

SAR result with Head TSL

SAR averaged over 1 cm³ (1 g) of Head TSL	Condition	
SAR measured	250 mW input power	2.40 W/kg
SAR for nominal Head TSL parameters	normalized to 1W	9.27 W/kg \pm 17.0 % (k=2)

SAR averaged over 10 cm³ (10 g) of Head TSL	condition	
SAR measured	250 mW input power	1.55 W/kg
SAR for nominal Head TSL parameters	normalized to 1W	6.03 W/kg \pm 16.5 % (k=2)

Body TSL parameters

The following parameters and calculations were applied.

	Temperature	Permittivity	Conductivity
Nominal Body TSL parameters	22.0 °C	55.2	0.97 mho/m
Measured Body TSL parameters	(22.0 \pm 0.2) °C	53.8 \pm 6 %	1.02 mho/m \pm 6 %
Body TSL temperature change during test	< 0.5 °C	----	----

SAR result with Body TSL

SAR averaged over 1 cm³ (1 g) of Body TSL	Condition	
SAR measured	250 mW input power	2.50 W/kg
SAR for nominal Body TSL parameters	normalized to 1W	9.58 W/kg \pm 17.0 % (k=2)

SAR averaged over 10 cm³ (10 g) of Body TSL	condition	
SAR measured	250 mW input power	1.63 W/kg
SAR for nominal Body TSL parameters	normalized to 1W	6.30 W/kg \pm 16.5 % (k=2)

Appendix (Additional assessments outside the scope of SCS108)

Antenna Parameters with Head TSL

Impedance, transformed to feed point	52.0 Ω - 1.6 j Ω
Return Loss	- 31.9 dB

Antenna Parameters with Body TSL

Impedance, transformed to feed point	47.7 Ω - 3.4 j Ω
Return Loss	- 27.5 dB

General Antenna Parameters and Design

Electrical Delay (one direction)	1.386 ns
----------------------------------	----------

After long term use with 100W radiated power, only a slight warming of the dipole near the feedpoint can be measured.

The dipole is made of standard semirigid coaxial cable. The center conductor of the feeding line is directly connected to the second arm of the dipole. The antenna is therefore short-circuited for DC-signals. On some of the dipoles, small end caps are added to the dipole arms in order to improve matching when loaded according to the position as explained in the "Measurement Conditions" paragraph. The SAR data are not affected by this change. The overall dipole length is still according to the Standard.

No excessive force must be applied to the dipole arms, because they might bend or the soldered connections near the feedpoint may be damaged.

Additional EUT Data

Manufactured by	SPEAG
Manufactured on	July 22, 2011

DASY5 Validation Report for Head TSL

Date: 10.07.2014

Test Laboratory: SPEAG, Zurich, Switzerland

DUT: Dipole 835 MHz; Type: D835V2; Serial: D835V2 - SN: 4d132

Communication System: UID 0 - CW; Frequency: 835 MHz

Medium parameters used: $f = 835$ MHz; $\sigma = 0.94$ S/m; $\epsilon_r = 41.1$; $\rho = 1000$ kg/m³

Phantom section: Flat Section

Measurement Standard: DASY5 (IEEE/IEC/ANSI C63.19-2011)

DASY52 Configuration:

- Probe: ES3DV3 - SN3205; ConvF(6.22, 6.22, 6.22); Calibrated: 30.12.2013;
- Sensor-Surface: 3mm (Mechanical Surface Detection)
- Electronics: DAE4 Sn601; Calibrated: 30.04.2014
- Phantom: Flat Phantom 4.9L; Type: QD000P49AA; Serial: 1001
- DASY52 52.8.8(1222); SEMCAD X 14.6.10(7331)

Dipole Calibration for Head Tissue/Pin=250 mW, d=15mm/Zoom Scan (7x7x7)/Cube 0:

Measurement grid: dx=5mm, dy=5mm, dz=5mm

Reference Value = 56.43 V/m; Power Drift = 0.00 dB

Peak SAR (extrapolated) = 3.62 W/kg

SAR(1 g) = 2.4 W/kg; SAR(10 g) = 1.55 W/kg

Maximum value of SAR (measured) = 2.83 W/kg

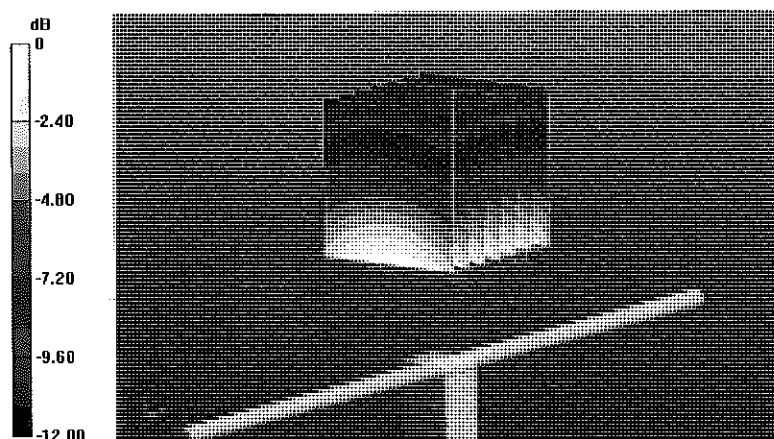

0 dB = 2.83 W/kg = 4.52 dBW/kg

Impedance Measurement Plot for Head TSL

10 Jul 2014 11:02:43

[CH1] S11 1 U FS 1: 52.027 Δ -1.6016 Δ 119.01 pF 835.000 000 MHz

*
De1
C Δ

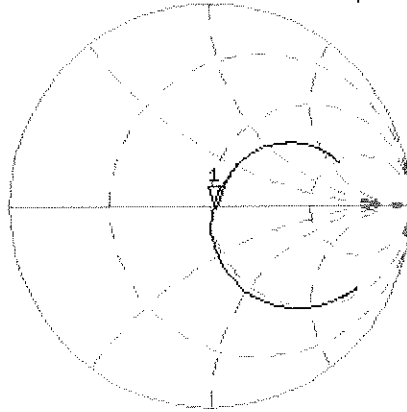

Avg
16

H1d

CH2 S11 LOG 5 dB/REF -20 dB 1: -31.921 dB 835.000 000 MHz

C Δ

Avg
16

H1d

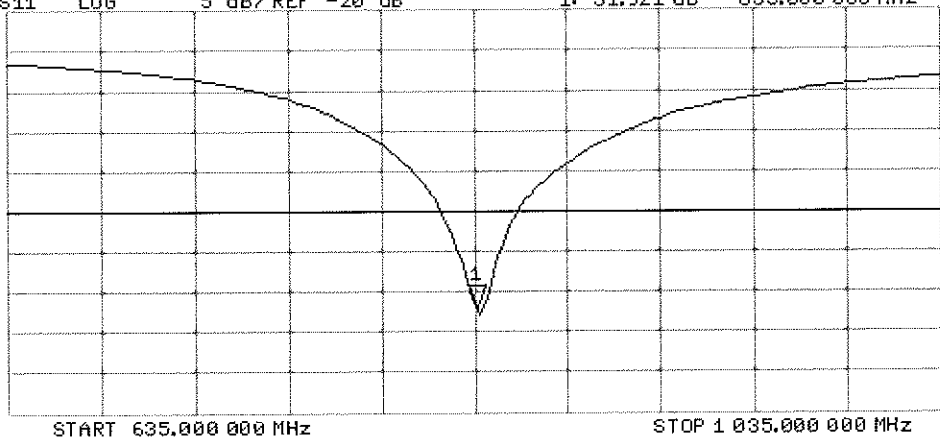

DASY5 Validation Report for Body TSL

Date: 09.07.2014

Test Laboratory: SPEAG, Zurich, Switzerland

DUT: Dipole 835 MHz; Type: D835V2; Serial: D835V2 - SN: 4d132

Communication System: UID 0 - CW; Frequency: 835 MHz

Medium parameters used: $f = 835 \text{ MHz}$; $\sigma = 1.02 \text{ S/m}$; $\epsilon_r = 53.8$; $\rho = 1000 \text{ kg/m}^3$

Phantom section: Flat Section

Measurement Standard: DASY5 (IEEE/IEC/ANSI C63.19-2011)

DASY52 Configuration:

- Probe: ES3DV3 - SN3205; ConvF(6.09, 6.09, 6.09); Calibrated: 30.12.2013;
- Sensor-Surface: 3mm (Mechanical Surface Detection)
- Electronics: DAE4 Sn601; Calibrated: 30.04.2014
- Phantom: Flat Phantom 4.9L; Type: QD000P49AA; Serial: 1001
- DASY52 52.8.8(1222); SEMCAD X 14.6.10(7331)

Dipole Calibration for Body Tissue/ $P_{in}=250 \text{ mW}$, $d=15\text{mm}$ /Zoom Scan (7x7x7)/Cube 0:

Measurement grid: $dx=5\text{mm}$, $dy=5\text{mm}$, $dz=5\text{mm}$

Reference Value = 55.35 V/m; Power Drift = -0.00 dB

Peak SAR (extrapolated) = 3.72 W/kg

SAR(1 g) = 2.5 W/kg; SAR(10 g) = 1.63 W/kg

Maximum value of SAR (measured) = 2.91 W/kg

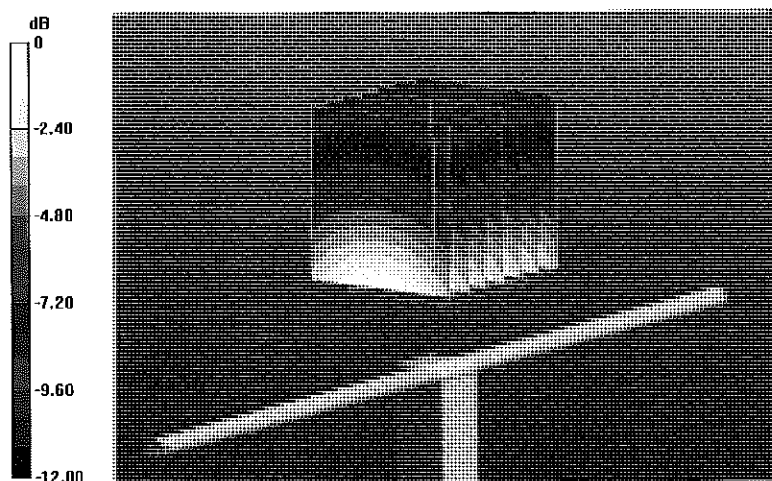

0 dB = 2.91 W/kg = 4.64 dBW/kg

Impedance Measurement Plot for Body TSL

9 Jul 2014 09:46:12

CH1 S11 1 U FS 1: 47.682 Ω -3.3965 Ω 56.118 pF 835.000 000 MHz

*
De1

CA

Avg
16

H1d

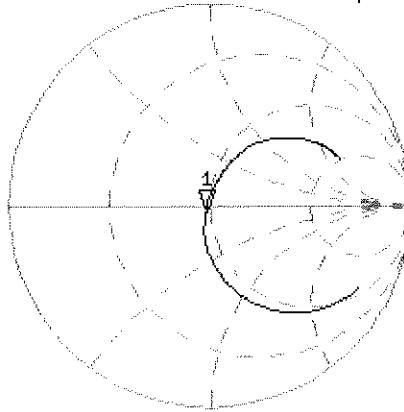

CH2 S11 LOG 5 dB/REF -20 dB 1: -27.522 dB 835.000 000 MHz

CA

Avg
16

H1d

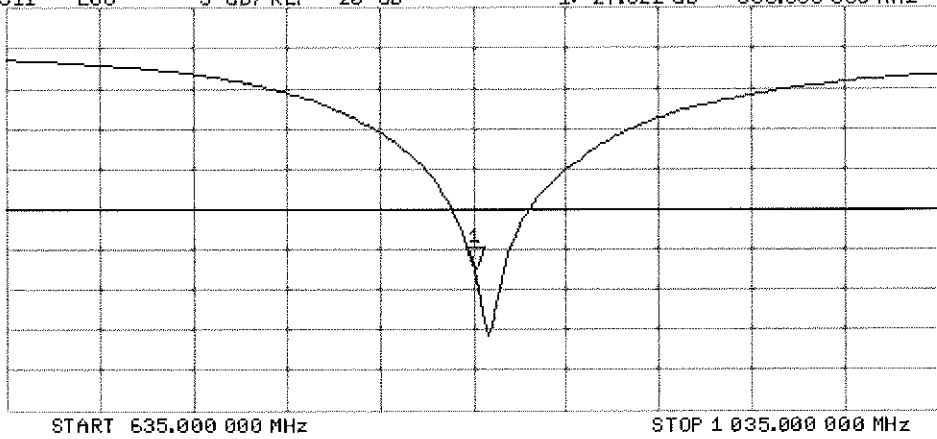



Accredited by the Swiss Accreditation Service (SAS)
The Swiss Accreditation Service is one of the signatories to the EA
Multilateral Agreement for the recognition of calibration certificates

Accreditation No.: **SCS 108**

Client **PC Test**

Certificate No: **ES3-3213_Apr14**

CALIBRATION CERTIFICATE

Object	ES3DV3 - SN:3213
Calibration procedure(s)	QA CAL-01.v9, QA CAL-23.v5, QA CAL-25.v6 Calibration procedure for dosimetric E-field probes
Calibration date:	April 11, 2014

This calibration certificate documents the traceability to national standards, which realize the physical units of measurements (SI).
The measurements and the uncertainties with confidence probability are given on the following pages and are part of the certificate.

All calibrations have been conducted in the closed laboratory facility: environment temperature (22 ± 3)°C and humidity < 70%.

Calibration Equipment used (M&TE critical for calibration)

CC-V
5/7/14

Primary Standards	ID	Cal Date (Certificate No.)	Scheduled Calibration
Power meter E4419B	GB41293874	03-Apr-14 (No. 217-01911)	Apr-15
Power sensor E4412A	MY41498087	03-Apr-14 (No. 217-01911)	Apr-15
Reference 3 dB Attenuator	SN: S5054 (3c)	03-Apr-14 (No. 217-01915)	Apr-15
Reference 20 dB Attenuator	SN: S5277 (20x)	03-Apr-14 (No. 217-01919)	Apr-15
Reference 30 dB Attenuator	SN: S5129 (30b)	03-Apr-14 (No. 217-01920)	Apr-15
Reference Probe ES3DV2	SN: 3013	30-Dec-13 (No. ES3-3013_Dec13)	Dec-14
DAE4	SN: 660	13-Dec-13 (No. DAE4-660_Dec13)	Dec-14
Secondary Standards	ID	Check Date (in house)	Scheduled Check
RF generator HP 8648C	US3642U01700	4-Aug-99 (in house check Apr-13)	In house check: Apr-16
Network Analyzer HP 8753E	US37390585	18-Oct-01 (in house check Oct-13)	In house check: Oct-14

Calibrated by:	Name Leif Klysner	Function Laboratory Technician	Signature
Approved by:	Katja Pokovic	Technical Manager	

Issued: April 14, 2014

This calibration certificate shall not be reproduced except in full without written approval of the laboratory.



Accredited by the Swiss Accreditation Service (SAS)

Accreditation No.: **SCS 108**

The Swiss Accreditation Service is one of the signatories to the EA Multilateral Agreement for the recognition of calibration certificates

Glossary:

TSL	tissue simulating liquid
NORM _{x,y,z}	sensitivity in free space
ConvF	sensitivity in TSL / NORM _{x,y,z}
DCP	diode compression point
CF	crest factor (1/duty_cycle) of the RF signal
A, B, C, D	modulation dependent linearization parameters
Polarization φ	φ rotation around probe axis
Polarization ϑ	ϑ rotation around an axis that is in the plane normal to probe axis (at measurement center), i.e., $\vartheta = 0$ is normal to probe axis
Connector Angle	information used in DASY system to align probe sensor X to the robot coordinate system

Calibration is Performed According to the Following Standards:

- a) IEEE Std 1528-2013, "IEEE Recommended Practice for Determining the Peak Spatial-Averaged Specific Absorption Rate (SAR) in the Human Head from Wireless Communications Devices: Measurement Techniques", June 2013
- b) IEC 62209-1, "Procedure to measure the Specific Absorption Rate (SAR) for hand-held devices used in close proximity to the ear (frequency range of 300 MHz to 3 GHz)", February 2005

Methods Applied and Interpretation of Parameters:

- *NORM_{x,y,z}*: Assessed for E-field polarization $\vartheta = 0$ ($f \leq 900$ MHz in TEM-cell; $f > 1800$ MHz: R22 waveguide). *NORM_{x,y,z}* are only intermediate values, i.e., the uncertainties of *NORM_{x,y,z}* does not affect the E^2 -field uncertainty inside TSL (see below *ConvF*).
- *NORM(f)_{x,y,z}* = *NORM_{x,y,z}* * *frequency_response* (see Frequency Response Chart). This linearization is implemented in DASY4 software versions later than 4.2. The uncertainty of the frequency response is included in the stated uncertainty of *ConvF*.
- *DCP_{x,y,z}*: DCP are numerical linearization parameters assessed based on the data of power sweep with CW signal (no uncertainty required). DCP does not depend on frequency nor media.
- *PAR*: PAR is the Peak to Average Ratio that is not calibrated but determined based on the signal characteristics
- *A_{x,y,z}; B_{x,y,z}; C_{x,y,z}; D_{x,y,z}; VR_{x,y,z}*: *A, B, C, D* are numerical linearization parameters assessed based on the data of power sweep for specific modulation signal. The parameters do not depend on frequency nor media. *VR* is the maximum calibration range expressed in RMS voltage across the diode.
- *ConvF and Boundary Effect Parameters*: Assessed in flat phantom using E-field (or Temperature Transfer Standard for $f \leq 800$ MHz) and inside waveguide using analytical field distributions based on power measurements for $f > 800$ MHz. The same setups are used for assessment of the parameters applied for boundary compensation (alpha, depth) of which typical uncertainty values are given. These parameters are used in DASY4 software to improve probe accuracy close to the boundary. The sensitivity in TSL corresponds to *NORM_{x,y,z}* * *ConvF* whereby the uncertainty corresponds to that given for *ConvF*. A frequency dependent *ConvF* is used in DASY version 4.4 and higher which allows extending the validity from ± 50 MHz to ± 100 MHz.
- *Spherical isotropy (3D deviation from isotropy)*: in a field of low gradients realized using a flat phantom exposed by a patch antenna.
- *Sensor Offset*: The sensor offset corresponds to the offset of virtual measurement center from the probe tip (on probe axis). No tolerance required.
- *Connector Angle*: The angle is assessed using the information gained by determining the *NORM_x* (no uncertainty required).